

CLARK AND WESTON STANDARD CELLS.

By F. A. Wolff and C. E. Waters.

INTRODUCTION.

The important rôle now played by the standard cell in both technical and scientific work, and the possibility of its adoption as a *primary* standard of electromotive force, have led in recent years to a considerable number of investigations concerning its reproducibility and constancy. The character of these investigations and the results obtained will, however, be better understood after a brief review of the previous work on the subject.

The need of a definite and universal system of electrical units was early recognized. Owing to its preponderating importance in the earlier applications of electricity, the unit of resistance naturally received first attention. The committee on electrical standards appointed by the British Association in 1861 recommended the adoption of the C. G. S. electromagnetic system together with a practical system defined as decimal multiples and submultiples of the C. G. S. units. In addition, its labors led to the construction of concrete standards of resistance in the form of coils of platinum-silver of special design adjusted to represent 10^9 C. G. S. units as determined by a series of absolute measurements.

The definition of unit current and electromotive force in terms of the C. G. S. units long met every requirement, particularly as currents were generally measured by the aid of the tangent galvanometer, while electromotive forces were generally measured in terms of the electromotive force of the Daniell cell.

In 1872 Latimer Clark called to the attention of the British Association committee the superiority of the cell which now bears his

name, recommending it as a suitable standard of electromotive force. In its original form¹ it consisted of a mercury electrode covered with a paste made of mercurous sulphate, zinc sulphate crystals and solution, while a rod of zinc in a saturated zinc sulphate solution above the mercury and paste and in contact with an excess of zinc sulphate crystals formed the second electrode. It will thus be seen that Clark fully appreciated the importance of reversibility, a fundamental condition to be satisfied by the standard cell. Clark also foresaw nearly all of the modern applications of the standard cell, as for example in the calibration of the ballistic galvanometer, in maintaining a current at a constant value, in the measurement of currents and electromotive forces, etc. No action was, however, taken on the suggestion by the committee.

The discovery of considerable error in the British Association ohm determination, the rapid development of electrotechnics, and the resulting demand for increased accuracy induced the French Government to issue a call for an international electrical congress to meet in Paris in 1881. This was followed by an international commission, recommended by the congress, which met in 1882 and 1884, and which defined the ohm in terms of the Siemens mercury unit, the ampere as one-tenth of a C. G. S. unit of current and the volt in terms of the ohm and ampere.

While the demands for accuracy of reproduction were fully met by the mercury ohm, the definitions of the ampere and the volt were found to be far from satisfactory. During the next few years attention was therefore directed to the investigation of the silver coulometer and the Clark cell. The former was studied by Mascart⁽²⁾, Rayleigh and Sidgwick⁽³⁾, Kohlrausch⁽⁴⁾, and others.

Rayleigh's⁵ investigations on the Clark cell showed that the main variations could be traced to impurities in the materials employed and to a faulty construction, the zinc not being completely covered with zinc sulphate crystals, thus retarding the attainment of saturation equilibrium for the temperature of observation. To remedy

¹ Phil. Trans. Roy. Soc., **164**, p. 1; 1874.

² Jour. de Phys. (2), **1**, p. 109; 1882. Jour. de Phys. (2), **3**, p. 283; 1884.

³ Phil. Trans. Roy. Soc., **175**, p. 411; 1884.

⁴ Wied. Ann., **27**, p. 1; 1886.

⁵ Phil. Trans. Roy. Soc., **176**, p. 781; 1885.

the latter defect Rayleigh proposed the H cell in which the zinc rod of the older type was replaced by zinc amalgam. Another cause of wide variations in Clark cells was found by Rayleigh to be a transformation of zinc sulphate, stable at ordinary temperatures as heptahydrate, into the hexahydrate at temperatures above 40°. Rayleigh showed that the inverted form persisted in a metastable condition for a long period after cooling, thus explaining the abnormal values which were frequently observed, and which were probably the rule when the older specifications which prescribed heating the constituents to boiling were followed.

Little further work was done on the Clark cell until shortly before the Chicago International Electrical Congress. In England the subject was taken up in 1891 by Glazebrook and Skinner,⁶ in connection with a committee appointed by the Board of Trade on Standards of Electrical Measurement. They studied the reproducibility of Clark cells constructed by themselves and others, determined the limits of error to be expected, and redetermined the electromotive force in terms of the electrochemical equivalent of silver. The cells set up by them were all of the Board of Trade type and an accuracy of only 0.01 per cent was sought.

The subject was taken up about the same time at the Reichsanstalt by Kahle,⁷ who used specially purified materials and made a careful study of the influence of added impurities. Practically all of his work was done with cells of the H type, with which trustworthy measurements could be made to a few hundred thousandths of a volt. Unfortunately, he employed only one sample of mercurous sulphate, the constituent which has since been found to be the main source of variation. Later he also made a redetermination of the temperature coefficient and the absolute value.⁸

From the results obtained it was found that there was little choice between the standard cell and coulometer from the standpoint of accuracy; indeed, both the coulometer and the cell were adopted in the definitions of the ampere and volt by the Chicago congress.

⁶ Phil. Trans. Roy. Soc., **183**, p. 567; 1892.

⁷ Zs. für Instrk., **12**, p. 117; 1892.

Zs. für Instrk., **13**, p. 293; 1893.

Wied. Ann., **51**, p. 174; 1894.

⁸ Zs. für Instrk., **18**, p. 230; 1898.

Wied. Ann., **67**, p. 1; 1899.

Subsequent to the Chicago congress the temperature coefficient of the Clark cell was redetermined by Jaeger and Kahle and also by Callendar and Barnes, with close agreement between the two.

Further studies on the hysteresis,⁹ polarization,¹⁰ and the inversion of zinc sulphate¹¹ were also made by various investigators.

In 1892 Edward Weston¹² described a cell in which the zinc and zinc sulphate of the Clark cell are replaced by cadmium and cadmium sulphate, respectively. It was discovered by Weston that a cadmium cell set up with a cadmium sulphate solution saturated at 4° had a negligible temperature coefficient. A portable type was also designed and has since been on the market.

The elaborate studies of the saturated type made at the Reichsanstalt by Jaeger and Wachsmuth,¹³ Jaeger,¹⁴ Jaeger and Kahle,¹⁵ and Jaeger and Lindeck,¹⁶ indicated that the Weston cell possessed all the merits of the Clark cell, besides having a much smaller temperature coefficient, showing no tendency to crack at the amalgam limb, so frequently observed with Clark cells, and not forming gas at the amalgam electrode.

In the specifications first proposed by Jaeger for the cadmium cell a 1:6 cadmium amalgam was recommended, the employment of which led to considerable mistrust, as irregularities of behavior were

- ⁹ Ayrton and Cooper: Proc. Roy. Soc., **59**, p. 368; 1896.
 Spiers, Twyman and Waters: Phil. Mag. (5), **45**, p. 285; 1896.
 Callendar and Barnes: Proc. Roy. Soc., **62**, p. 117; 1897.
- ¹⁰ Skinner: Phil. Mag. (5), **38**, p. 271; 1894.
 Wulf: Wien. Sitz-Ber. II a, July, 1897.
 Jaeger: Ann. d. Phys. (4), **14**, p. 726; 1904.
- ¹¹ Jaeger: Wied. Ann., **63**, p. 354; 1897.
 Callendar and Barnes: Proc. Roy. Soc., **62**, p. 117; 1897.
 Cohen: Zs. f. phys. Chem., **25**, p. 300; 1898.
 Cohen: Zs. f. phys. Chem., **31**, p. 164; 1899.
 Cohen: Zs. f. phys. Chem., **34**, p. 62; 612; 1900.
 Barnes: Jour. of Phys. Chem., **4**, p. 1; 1900.
- ¹² Electrician, Lond., **30**, p. 741; 1893.
- ¹³ Electrotech. Zs., **15**, p. 507; 1894.
- ¹⁴ Electrotech. Zs., **18**, p. 647; 1897.
- ¹⁵ Zs. für Instrk., **18**, p. 161; 1898.
 Wied. Ann., **65**, p. 926; 1898.
- ¹⁶ Zs. für Instrk., **21**, 33; 1901.
 Ann. d. Phys. (4), **5**, p. 1; 1901.

observed by Callendar and Barnes and confirmed by others¹⁷ at temperatures below 15°. These were first attributed to an inversion of the cadmium sulphate similar to that of zinc sulphate referred to above, but later investigations¹⁸ showed that they were undoubtedly due to the cadmium amalgam and were entirely eliminated by the employment of 12–13 per cent amalgams.

Further work by Bijl¹⁹ and Puschin²⁰ has shown that cadmium amalgams consist within certain temperature limits of a liquid phase and a solid phase, the composition of the latter depending on the temperature, and that the mixed crystal is therefore an isomorphous mixture of cadmium and mercury. With both phases coexistent, the electromotive force toward cadmium sulphate at a given temperature is independent of the relative amounts of the metals present, as found by Jaeger,²¹ while in the absence of the liquid phase irregularities in behavior are found. The composition of the amalgam to be employed in the standard cell must therefore be such that both phases will be present within the usual temperature range 0° to 40°, a condition satisfied by the 12.5 per cent amalgam, now in general use.

Previously unsuspected irregularities due to the mercurous sulphate were observed at the Reichsanstalt toward the end of 1900,²² when a sample of mercurous sulphate, obtained from a different source, was employed. Even after the cells had reached constant values they were still several tenths of a millivolt higher than the older cells all made from another sample of mercurous sulphate.

In 1904 an investigation of the subject was begun in temporary quarters at the Bureau of Standards by one of the authors and Dr.

¹⁷ Callendar and Barnes: *Electrician*, **39**, p. 638; 1897.

Cohen: *Wied. Ann.*, **65**, p. 344; 1898.

Cohen: *Zs. f. phys. Chem.*, **34**, p. 621; 1900.

¹⁸ Jaeger: *Wied. Ann.*, **65**, p. 106; 1898.

Zs. für Instrk., **20**, p. 317; 1900.

Ann. d. Phys. (4), **3**, p. 366; 1900.

Ann. d. Phys. (4), **4**, p. 123; 1901.

von Steinwehr: *Ann. d. Phys.* (4), **9**, p. 1046; 1902.

¹⁹ *Zs. für phys. Chem.*, **41**, p. 641; 1902.

²⁰ *Jr. Russ. phys. Chem. Soc.*, **34**, p. 856; 1902.

Zs. für anorg. Chem., **36**, p. 201; 1903.

²¹ *Wied. Ann.*, **65**, p. 106; 1898.

²² Jaeger and Lindeck: *Zs. für Instrk.*, **21**, p. 73; 1901.

H. N. Stokes. Some preliminary work was done on the purification of materials, but efforts were mainly directed to the preparation of mercurous sulphate of uniform electromotive properties, an electrolytic method being devised. This method was described by one of the authors²³ at the Washington meeting of the American Electrochemical Society, April 7, 1904, at which a paper by Carhart and Hulett,²⁴ giving essentially the same method, was also read. A number of cells, set up with samples of mercurous sulphate prepared by this method, showed excellent agreement among themselves.²⁵ The work at the Bureau was interrupted by the establishment of the branch laboratory at St. Louis and by the extra work incident to moving into the new laboratories at Washington.

Considerable further work has been done by Hulett²⁶ on the reproducibility of the Weston cell, in connection with which a study was made of the influence of hydrolysis of the mercurous sulphate. It was shown by Gouy²⁷ that pure mercurous sulphate is hydrolyzed by water with the formation of a yellowish, difficultly soluble, basic product, which he stated is easily transformed into neutral mercurous sulphate by 0.1 normal sulphuric acid. He also stated that mercurous sulphate is not hydrolyzed by saturated solutions of zinc or cadmium sulphate.

Hulett, on the other hand, by rotating a sample of mercurous sulphate with mercury and successive portions of water at constant temperature, found that the electrical conductivity of the solution remained constant until all the mercurous sulphate was hydrolyzed, after which a different, fixed conductivity was observed. He found that the completely hydrolyzed product was gray, and not yellow. He also concluded that a soluble acid sulphate and a slightly soluble basic sulphate are formed, and that the hydrolyzed salt does not dissolve as such, but is further decomposed by water. He also determined the solubility curves of mercurous sulphate, in the pres-

²³Wolff: *Trans., Am. Electrochem. Soc.*, **5**, p. 49; 1904.

²⁴*Ibid.*, **5**, p. 59; 1904.

²⁵These were ruined by exposure to light after removal to the new laboratory and during Doctor Wolff's absence on duty at the St. Louis Exposition.

²⁶*Zs. für phys. Chem.*, **49**, p. 483; 1904.

Phys. Rev., **22**, p. 321; 1906.

Phys. Rev., **23**, p. 166; 1906.

²⁷*Compt. rend.*, **130**, p. 1399; 1900.

ence of mercury, in sulphuric acid of varying concentrations, and found a maximum solubility at $V=1$ (V denoting the number of liters containing one mole sulphuric acid) and a break in the curve at $V=4$, from which he concluded that hydrolysis apparently begins at this dilution.

Hulett set up a considerable number of cells with samples of mercurous sulphate prepared by the electrolytic method, varying the current density and strength of acid between wide limits, and also with samples prepared by chemical methods. Where the concentration of the acid was less than molecular, the electrolytic samples, which were white even with the greatest current density, gave higher results than the gray samples obtained when stronger acid was used, and which showed excellent agreement among themselves. Less satisfactory results were obtained with samples prepared by chemical methods.

He also found that cells in which the depolarizer was a mixture of neutral and completely hydrolyzed mercurous sulphate gave values irregularly increasing with the percentage of basic sulphate employed. For other cells the mixture was prepared by rotating mercurous sulphate with definite amounts of water, thus giving a definite percentage of basic salt. These cells had, however, considerably higher values, for the same percentage of basic sulphate, than those mentioned above. The above results, unexpected in the light of the phase rule, are attributed to the possible formation of new phases. According to the above there should be a condition of unstable equilibrium to which Hulett attributes the slow decrease of e. m. f. observed by him in older cells. This was further tested by single electrodes charged with a mixture of mercury, mercurous sulphate and cadmium sulphate, the materials being rotated for a number of days in a thermostat. When measured against an amalgam electrode abnormally high values were observed, which decreased on stopping the rotation. These cells were not kept under observation long enough to determine whether normal values would be reached. It is to be noted that this effect will not account for the decrease in the e. m. f., observed by Hulett in the case of old cells, except on the assumption that further reaction takes place between the products of hydrolysis and the ingredients of the cell. This will be discussed more fully in a later paper.

At the Reichsanstalt a special study has been made of the influence of size of grain on the electromotive properties of mercurous sulphate. According to v. Steinwehr²⁸, this is mainly responsible for variations noted in the case of commercial samples, fine-grained samples giving, in accordance with theory, much higher values than coarse-grained ones. On grinding the latter he found a considerable increase in the e. m. f. and a very slow recovery.

Work on the standard cell has been in progress for several years at the English National Physical Laboratory,²⁹ but no detailed report of the results has been published. According to preliminary reports considerable progress has been made. Samples of mercurous sulphate prepared by three chemical methods agree in e. m. f. with samples prepared by the electrolytic method.

In October, 1905, the work was resumed by the present authors with the object of investigating the purification and preparation of materials for Clark and Weston cells, the influence of impurities, and any other sources of variation, such as size of grain, etc., influencing the electromotive force.

A systematic study of reproducibility can of course be made only by comparing the various materials in actual cells in which only one ingredient is varied at a time. It was therefore necessary to set up a large number, and in order to employ identical materials a considerable supply had to be accumulated, which, in the case of cadmium sulphate, required a long time, as our object was, at first, to employ only clear crystals, though it has since been found that cloudy crystals from a purified solution give the same electromotive force.

The details and results of the work done at the Bureau of Standards, a brief account of which was given at the New York meeting of the American Physical Society, December, 1906,³⁰ are submitted below under the following heads:

²⁸Zs. für Instrk., **25**, p. 205; 1905.

Zs. für Elektrochem., **12**, p. 578; 1906.

²⁹Smith: B. A. Reports 1904, 1905, and 1906.

Electrician (Lond.), **55**, p. 857; 1905.

³⁰Wolff and Waters: El. World, **49**, p. 100; 1907.

Phys. Rev., **24**, p. 252; 1907.

Electrician (Lond.), **58**, p. 692; 1907.

Preparation and purification of materials.

The cells.

The comparing baths.

The electrical measurements.

Tabulation of results.

Discussion of results.

General conclusions.

PREPARATION AND PURIFICATION OF THE MATERIALS.

Mercury.—All the mercury used in this investigation was purified by distilling it at least twice in a current of air under greatly reduced pressure, according to Hulett and Minchin.³¹

The essential feature of this method is the oxidation of any metals that may distil with the mercury by means of a slow current of air, admitted through a tube drawn out at one end to a very fine capillary extending almost to the bottom of the distilling bulb. This tube passes through a tightly fitting cork in the neck of the bulb, and the flow of air is regulated by means of a pinchcock and a short piece of rubber tubing, the free end of which is plugged with cotton wool to filter out dust. To prevent charring the cork a bulb with the side tube as low as possible on the neck should be selected.

An ordinary distilling bulb, of about 500 cc capacity, is sealed to one end of a slightly inclined, wide tube, 2 cm in diameter and 50 cm long, which serves as the condenser. At the lower end of the condenser is sealed a vertical tube of 3 to 4 mm bore and 80 to 90 cm in length, and bent into S form at the lower end, which thus serves as a trap for the mercury, which runs out, as rapidly as it distils, into a beaker or small dish. A side tube must be sealed to the upper, slightly widened part of the vertical tube for making connection with an aspirator. On commencing the distillation the vertical tube is filled by placing under the lower end a small beaker of mercury and then starting the aspirator. Of course somewhat more of the first part of the distillate than is needed to fill the vertical tube must be rejected.

As an additional precaution against mercury being carried over by bumping, a Claisen distilling bulb, with two necks, instead of

³¹ Phys. Rev., **21**, p. 388; 1905.

one of the ordinary form, was employed by the authors, a thermometer being inserted in the second neck. The flask was heated in a hemispherical iron dish, the bulb being surrounded by a loose cylindrical sheath of asbestos paper and a cover of asbestos board through which the necks of the flask passed. By using iron turnings in the bath, instead of sand, which might scratch the bulb, and allowing at least an hour for cooling before refilling with mercury, it was possible to distil a large quantity of mercury without any apparent damage to the bulb.

From time to time the still was cut apart, cleaned with nitric acid, washed and dried. Usually about four-fifths of the mercury was distilled over, and when it was not very impure, the residue was simply sucked from the flask by means of a pipette.

The surface of the distilled mercury was slightly coated with oxides of the metals originally contained in it. These were removed by passing it through a pinhole in a filter paper.

In most of the work commercial mercury was distilled at least twice by this method. Some which had been used in the laboratory and was badly contaminated was, however, first subjected to a preliminary purification by electrolysis. This was found to be simpler and more efficient than the usual treatment with dilute nitric acid or mercurous nitrate, the action of which is necessarily superficial and therefore slow.

By making the mercury the anode, a piece of platinum foil the cathode, and using 2 per cent nitric acid as the electrolyte, the more positive metals go almost completely into solution by electrolysis, leaving in the mercury the less positive metals which exert only a minor influence on the e. m. f. and which may with the others be afterwards removed by distillation as described above.

With a current density of about 0.5 ampere per square decimeter, the electrolysis was continued, constantly stirring the mercury, for some hours after it no longer tailed, the time required depending on the amount and the original condition of the sample. The mercury deposited on the cathode, possibly containing some of the electro-positive impurities, was prevented from dropping back into the anode mercury by suspending under the cathode a small beaker hung from the side of the battery jar by means of a support made of glass rod. The combination anode and stirrer described below

was used. The depth of the mercury was great enough to completely cover the blades of the stirrer when rotating, and the volume of dilute acid employed was about four times that of the mercury.

Twenty kilos of mercury, very impure from use in the laboratory, were subjected to this purification using a current of 1 ampere for seventeen hours, and then distilled in three successive portions, leaving the residue in the bulb each time. Then 7 kilos more of mercury, also purified electrolytically, were introduced and distilled. The final residue, amounting to about 1 kilo, was analyzed. Traces of zinc, iron, and copper, and a small amount of lead were found. In the mercury before distillation no lead was found and only a doubtful reaction for zinc was obtained, while copper and iron were detected.

Zinc.—To remove small quantities of cadmium, lead, iron, and arsenic ordinarily contained in the commercial chemically pure metal, a considerable quantity of Kahlbaum's best zinc was repeatedly distilled under diminished pressure according to the method of Morse and Burton.³² A large tube of Jena combustion glass was closed at one end, the zinc introduced, and the tube drawn out at equal intervals, thus forming three reservoirs. The narrow portions were arched somewhat to prevent the melted metal from flowing from one section to another. The tube was placed in a combustion furnace, connected by means of a rubber stopper and heavy tubing to a Geryk pump and exhausted, the pump being kept running, not only during the distillation but afterwards, until the tube cooled. The latter was first heated at the closed end and by smaller flames under the second section, care being taken not to allow the tube to soften and collapse. The flames were regulated so that nearly all the metal condensed in the second section. When about three-fourths of the zinc had distilled off, the second section was more strongly heated and the zinc distilled into the third section, thus effecting a double distillation in practically one operation. The flames under the closed end of the tube were turned low, but not extinguished, so that the metal would not distil back again into the first section. The flames were then extinguished, but air was not admitted until the tube was cold. The distilled metal adhered

³²Am. Chem. Jour., 10, p. 311; 1888.

strongly to the glass, which was removed by hammering with a porcelain pestle.

In some of the work, zinc, which had been distilled in this manner three times, was used, but in most of the cells Kahlbaum's best zinc was employed without further treatment, as it was found to give identical results.

Cadmium.—Kahlbaum's best cadmium, prepared electrolytically, was distilled five times in the same manner as the zinc.³³ In most of the cells, however, the metal was used without further treatment. Although considerable platinum was found in the residues and a trace of arsenic in the portions of the distillate which condensed beyond the third section of the tube, the original metal was found to give the same results.

Amalgams.—*Zinc amalgam*, containing 10 per cent by weight of zinc, was prepared by dissolving a weighed amount of pure zinc in nine times its weight of pure mercury. The latter was heated gently in a porcelain dish on a sand bath. The zinc, previously treated with very dilute sulphuric acid to remove the film of oxide, then washed with water and dried, was placed upon the hot mercury and frequently stirred to hasten solution, the heat being increased whenever the amalgam showed a tendency to solidify.

Cadmium amalgam, containing 12.5 per cent by weight of cadmium, was prepared in the same manner. On account of its relatively low melting point it was, however, prepared on the steam bath.

Oxidation of the amalgams.—On exposure to the air the surfaces of the amalgams are slowly tarnished by oxidation; but as considerable changes in composition have no appreciable influence on the electromotive force, this is of no practical importance. The oxidation is lessened by keeping the amalgam under a solution of zinc or cadmium sulphate; but in the course of time a deposit of basic salt is formed. Apart from the fact that the use of these solutions does not completely prevent oxidation is the further objection that the pipette used in introducing the amalgam into the cells may become coated with basic sulphate. In addition, the zinc amalgam must be heated so high that there is violent bumping. Accordingly this method of removing the oxide was abandoned, and the melted

³³ Morse and Jones: *Am. Chem. Jour.*, **14**, p. 261; 1892.

amalgam was simply strained, when necessary, through a test tube drawn out at the bottom to a small opening and heated gently from time to time to keep the amalgam melted.

Zinc sulphate.—The salt is apt to contain sulphates of cadmium, iron, lead, etc., and free sulphuric acid. The last of these has the greatest effect upon the e. m. f., and promotes the formation of gas in the amalgam limb. Although the effect of such small quantities of the other impurities as are apt to be contained in the chemically pure salt is practically negligible, the following methods of purification, both giving the same results with zinc sulphate from Kahlbaum and from the J. T. Baker Company, were used:

The chemically pure salt, as purchased, was dissolved in hot water, an excess of pure zinc oxide and sufficient pure hydrogen peroxide to effect the oxidation of any ferrous iron added and the solution kept at nearly the boiling point for several hours to throw down iron as completely as possible. It was then filtered, acidified slightly, and evaporated until the zinc sulphate began to crystallize out, then cooled with ice (5° or lower), stirring frequently meanwhile so as to obtain small crystals. These were filtered off, using a platinum cone, washed once or twice with very little ice-cold water, redissolved in a little hot water, and recrystallized as before. Further crops of crystals were obtained from the first and second mother-liquors, those from the first being recrystallized once, those from the second mother-liquor twice. The three lots of crystals were then combined and dissolved in sufficient warm water to form a saturated solution. The temperature was not allowed to exceed 35° to avoid the formation of the hexahydrate, which is stable above 39° . The solution was filtered, and with continuous stirring, cooled by surrounding the beaker with ice. The crystals were filtered off, using a platinum cone, and washed two or three times with a little ice-cold water. The air-dried crystals were preserved in a well stoppered bottle.

The zinc oxide employed was prepared by adding ammonia to a solution of zinc sulphate until the precipitate dissolved. It was then filtered into a large volume of water, allowed to settle, the supernatant liquid decanted, and the precipitate thoroughly washed on a Büchner funnel (using a hardened filter paper), removed from

the filter paper and ignited in a platinum crucible inclosed in one of porcelain to prevent access of reducing gases.

The zinc sulphate was also purified by electrolysis.³⁴ After removal of iron, as described above, a weak current (about 0.1 ampere per square decimeter) was passed through a nearly saturated solution containing suspended zinc oxide to keep it slightly basic. Platinum electrodes were used and the solution stirred continuously. The electrolysis was continued for several days until a clean anode no longer became coated with lead peroxide. The solution was sufficiently pure, though it still contained traces of other metals. It was filtered, acidified slightly, and the salt twice crystallized by evaporating to a small volume. The last crop of crystals was dissolved in a small quantity of water at room temperature and the solution allowed to evaporate spontaneously. Large, perfect crystals were obtained.

Cadmium sulphate.—The commercial chemically pure salt may contain zinc, lead, ferrous and ferric iron, and occasionally nickel. Several lots of the salt were purified by dissolving in an excess of water at about 70°, filtering when necessary, adding an excess of basic cadmium sulphate and a few cubic centimeters of hydrogen peroxide to oxidize any ferrous iron present and heating for some hours. The solution was then filtered, acidified slightly, and evaporated nearly at its boiling point in a large porcelain dish resting on a pipestem triangle on a hot plate or supported some distance above the flame of a gas stove. Even then the flakes of the lower hydrate of cadmium sulphate which were formed collected on the bottom and caused violent bumping unless they were frequently removed. The crystals were allowed to drain in a funnel with a platinum cone. When the solution had been evaporated to a small volume it was poured, while still hot, through the funnel, the crystalline flakes packed down with a pestle, allowed to cool, and washed twice with a little cold water, using suction. They were then redissolved and the solution evaporated down to a small volume, as before. After this operation the crystals were dissolved in a slight excess of water at room temperature. The solution was filtered when necessary, and then set aside in shallow layers (2 to 3 cm) in

³⁴ Mylius and Fromm: *Zs. f. anorg. Chem.*, **9**, p. 144; 1895.

crystallizing dishes covered with filter paper. The solution should not be saturated when placed in the dishes, especially if it be a mother liquor from which a crop of crystals has been removed, for the salt is almost certain to come down in a few hours as a crust over the bottom instead of isolated crystals. At least three-fourths of the crystals were cloudy, but these were found to give the same results in the cells as the perfectly clear ones. By varying the rate of evaporation and by using acid, neutral and basic solutions, it was attempted to obtain a larger proportion of clear crystals, but without success. The latter, especially, adhered so firmly to the bottom of the dish that they were apt to be broken in removal. This was obviated by decanting the mother liquor and pouring a little pure water over the crystals. In a few moments they became loose, without going into solution to any great extent, and were easily removed with a spatula. They were washed two or three times with water and preserved air-dried in bottles.

Zinc and cadmium sulphate solutions.—The saturated zinc or cadmium sulphate solutions required for making up the paste and for filling the cells were prepared by agitating an excess of purified salt with distilled water. In the case of zinc sulphate shaking with water heated to not more than 35° for at least a half hour was sufficient, while for cadmium sulphate mechanical stirring for three or four hours was required on account of the slowness with which it dissolved.

Mercurous sulphate.—The chemically pure mercurous sulphate at present obtainable on the market may contain as impurities basic mercurous sulphate, basic mercuric sulphate, traces of nitrate, etc., according to the method of preparation. In addition the size of grain of the commercial samples, usually prepared by rapid precipitation, may also have an influence on its electromotive properties. Such materials can not, therefore, be directly employed if the highest accuracy of reproduction is sought. A considerable number of samples of mercurous sulphate was prepared by the following methods:

- (a) By electrolysis, old apparatus.
- (b) By electrolysis, new apparatus.
- (c) By the action of fuming sulphuric acid on mercury.
- (d) By the reaction between sulphuric acid and mercurous nitrate.

(*e*) By the action of a dilute solution of nitric acid in sulphuric acid on mercury.

(*f*) By the reduction of mercuric sulphate by mercury.

(*g*) By the reduction of mercuric sulphate by sulphurous acid.

(*h*) By the recrystallization of commercial mercurous sulphate from sulphuric acid.

(*i, k, l, m, n*) By digestion of commercial mercurous sulphate with sulphuric acid.

All the samples were prepared in subdued light and preserved in the dark, to protect them from the action of light. Even diffused daylight soon darkens the salt.

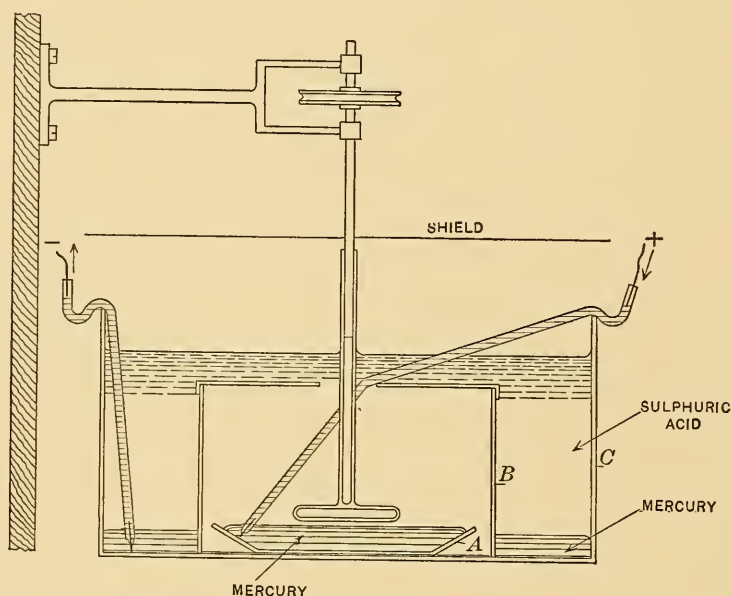

Fig. 1.—Apparatus for Electrolytic Preparation of Mercurous Sulphate (1904).

(*a*) *By electrolysis, old apparatus.*—In 1904 an electrolytic method of preparation was developed by one of the authors,³⁵ and also independently by Carhart and Hulett,³⁶ the mercurous sulphate being formed by the passage of a current at the surface of a mercury anode in sulphuric acid. Preliminary experiments, based on the reversibility of the Clark and Weston standard cells, as shown by the slight polarization with weak inverse currents, were made with cadmium sulphate solutions. Without stirring a crust of yellow basic mercurous sulphate formed on the surface of the mercury anode.

³⁵ Wolff: Trans. Amer. Electrochem. Soc., 5, p. 49; 1904.

³⁶ Ibid., 5, p. 59; 1904.

rous and mercuric sulphate was formed and the solution gave a very strong mercuric reaction, while with an acidified solution a beautiful crystalline product was obtained.

The anode mercury was contained in a shallow plate, *A* (fig. 1), resting on the bottom of a crystallizing dish, *B*, of slightly greater diameter, placed inside of a second larger crystallizing dish, *C*, which contained the cathode mercury. Both dishes were filled with dilute sulphuric acid, covering the inner dish to a depth of several centimeters. Electrical connections were made in the usual manner by means of glass tubes with platinum terminals fused into the lower ends and filled with mercury. To prevent the possible formation of basic compounds and mercuric sulphate, the solution near the surface of the anode was stirred continuously. In this way, and with a current density not greater than 0.25 ampere per square decimeter, the surface of the anode was kept in motion and the mercurous sulphate was swept over the edges of the plate as rapidly as it was

TABLE I.

Electrolytic Method, Old Apparatus.

Sample	Made	Conc. of H_2SO_4	Remarks
a_1	Jan., '04	5%	+5% CdSO_4
a_4^1	Mar., '04	2.5%	
a_5	Apr., '04	5%	} Slightly brownish on exposed surfaces Mar., '06
a_6	Apr., '04	5%	
a_7	May, '04	1:6	
a'_7	May, '04	1:6	a_7 digested with 25% H_2SO_4
a_8	May, '04	1:6	
a'_8	May, '04	1:6	From top of cover dish
a_9	June, '04	1:6	
a_{10}	Sept., '05	1:6	From inside dish
a'_{10}	Sept., '05	1:6	From outside dish
a_{11}	Sept., '05	1:6	From inside dish
a'_{11}	Sept., '05	1:6	From outside dish
a_{12}	Oct., '05	1:6	
a_{13}	Oct., '05	1:6	

¹ Samples a_2 and a_3 not preserved.

formed. To prevent mechanical loss the inner dish was covered with a perforated crystallizing dish, through which the glass stirrer and anode connection passed. A metallic shield attached to the shaft of the stirrer prevented possible contamination by oil and particles of metal from the bearing.

Nine samples, of which seven were preserved, were made in 1904, and four others in 1905, using this form of apparatus, which was

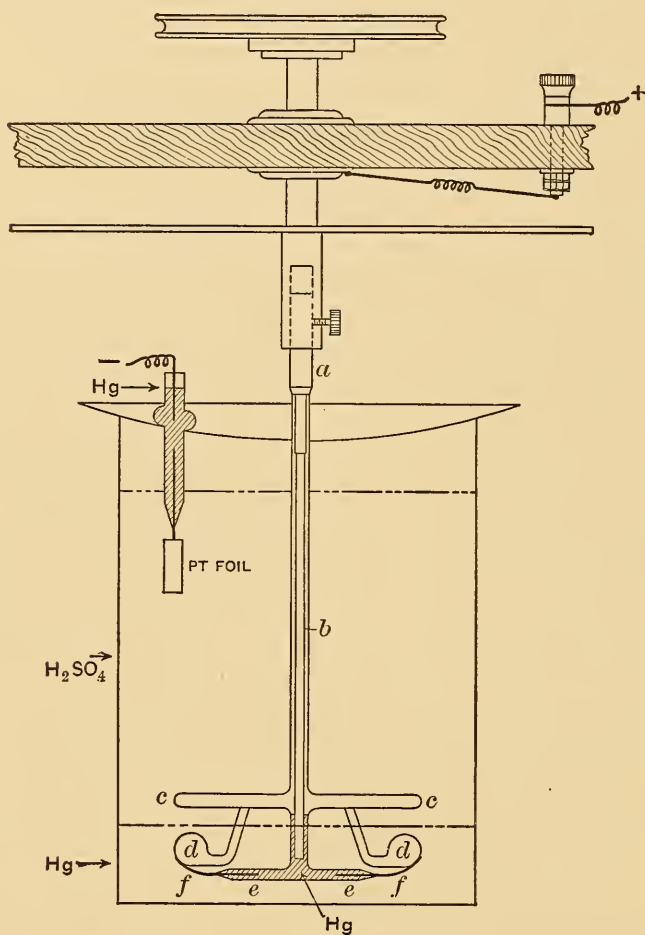

Fig. 2.—Apparatus for Electrolytic Preparation of Mercurous Sulphate (1905).

designed to give a white product free from finely divided mercury, as per Table I. The current density was kept below 0.25 ampere per square decimeter in the preparation of all the samples.

(b) *Electrolytic method, new apparatus.*—In the preparation of the remaining samples of electrolytic mercurous sulphate, the apparatus was so modified as to permit the use of greater current densities, which necessitated more efficient stirring. A layer of mercury 3 to 4 cm deep, purified as described above, was placed in a battery jar

about 12 cm in diameter and 20 cm in depth, and the jar nearly filled with dilute sulphuric acid. A piece of platinum foil, about 3 cm square, in the upper part of the solution served as cathode. The foil was welded to a short piece of platinum wire, the other end of which was sealed into the end of a short glass tube to serve as a mercury connection. A small bulb was blown about the middle of the tube, so that it rested in a hole through the glass cover of

the jar. When making samples (b_1) to (b_9) a simple glass T-stirrer revolving close to the surface of the mercury was used, connections to the mercury anode being made as shown in fig. 1. The surface of the mercury was soon covered with a dark coating, and in addition some of the mercurous sulphate accumulated around the anode tube. A second stirrer was then made by attaching near the ends of the cross arm short glass rods, flattened to form paddles, which dipped into the mercury, so that both the mercury and the electrolyte could be stirred vigorously (samples b_{10} , b_{11} , b_{12}). As this form of stirrer did not prevent the accumulation of mercurous sulphate around the anode tube, a combination stirrer and anode connection was constructed. The two cross arms (fig. 2), cc and ee were about 3 cm apart, and the lower arm had a short piece of platinum wire sealed into each end. The paddles, dd , made of glass rod 2 to 2.5 mm in diameter, flattened at the end, were sealed to the cross arm, cc , and the platinum terminals, ff , thus also making the construction more rigid and preventing the platinum wires from being broken off during cleaning. Electrical contact was made with the bearing of the rotating apparatus by means of a copper wire, b , soldered into the lower end of the brass cylinder, a , and extending into the cross tube, ee . The latter and the lower part of the stem were filled with mercury, and the soldered joint was protected from amalgamation by a coat of Khotinsky cement. The operation was watched as the speed of the stirrer, driven by an electric motor, decreased after the formation of sulphate began.

The best position of the stirrer is readily determined by trial, and is that position in which the mercury is vigorously rotated without being broken up into small globules. A speed of 100 to 200 revolutions per minute was employed.

The product formed was light to dark gray, from the presence of finely divided mercury, depending upon the current density, strength of acid, and rate of stirring employed, all of which were varied between wide limits without appreciably affecting the electromotive properties of the product. To minimize the possible influence of size of grain the stirring was always continued for some hours after interrupting the current.

The mercurous sulphate, separated from the excess of mercury, which interfered with its subsequent washing, by means of a sep-

arating funnel (using no grease on the stopcock) or by means of a pipette, was then transferred to a clean glass-stoppered bottle and preserved in the dark under part of the electrolyte employed. Further data on the samples prepared by the modified apparatus are given in the table below.

TABLE II.
Electrolytic Method, New Apparatus.

Sample	Made	Current Density	Conc. of H ₂ SO ₄	Remarks
b ₁	Feb., '06	0.2 amp.	V=0.25	
b ₂	"	0.2	0.50	
b ₃	"	0.2	0.75	
b ₄	"	0.2	0.25	} Poor stirring
b ₅	"	0.2	0.50	
b ₆	"	0.2	0.75	
b ₇	"	0.5	0.25	
b ₈	"	0.5	0.50	
b ₉	"	0.5	0.75	
b ₁₀	"	1.0	0.25	
b ₁₁	"	1.0	0.50	
b ₁₂	"	1.0	0.75	
b ₁₃	"	5.0	0.50	
b ₁₄	Mar., '06	9.25	0.25	
b ₁₅	"	9.25	0.50	
b ₁₆	"	9.25	0.75	
b ₁₇	"	8	1	
b ₁₈	"	8	2	
b ₁₉	"	8	5	
b ₂₀	"	0.5	1	
b ₂₁	"	0.5	2	
b ₂₂	"	0.5	5	
b ₂₃	"	2	1	
b ₂₄	"	2	2	
b ₂₅	"	2	5	
b ₂₆	Dec., '06	5.25	1:6	
b ₂₇	"	5.25	1:6	
b ₂₈	"	5.25	1:6	
b ₂₉	Jan., '07	5.25	1:6	
b ₃₀	"	5.25	1:6	
b ₃₁	"	5.25	1:6	

(c) *By the action of fuming sulphuric acid on metallic mercury.*³⁷—Pure mercury was placed to a depth of about 3 mm in a porcelain dish and covered with four times its volume of fuming sulphuric acid, stirring from time to time and keeping the dish covered as far as possible on account of the acid fumes evolved. In spite of this the hood became filled with fumes. The action began in the cold but was greatly accelerated by the heat generated, so that the sulphate appeared in crystalline form after a few minutes. The operation was allowed to continue until action nearly stopped, when the reaction product was poured into a large beaker of 1:6 sulphuric acid, thoroughly stirred and allowed to settle. To avoid spattering, the beaker containing the dilute acid was covered with a perforated watch glass and the solution introduced through a narrow-stemmed funnel extending almost to the surface of the acid. The sulphuric acid was then decanted and the mercurous sulphate transferred with a little mercury and 1:6 sulphuric acid to a glass-stoppered bottle.

(d) *By the reaction between mercurous nitrate and sulphuric acid.*—Mercurous sulphate is ordinarily made by the reaction between mercurous nitrate and a soluble sulphate in order to avoid the presence of a large excess of free acid. For use in Clark and Weston cells precipitation by means of zinc or cadmium sulphate, respectively, has been recommended. It is, however, preferable to use comparatively strong sulphuric acid and to add the mercurous nitrate solution to it in order to avoid possible hydrolysis.

A concentrated solution of mercurous nitrate was prepared by the action of concentrated nitric acid on an *excess* of mercury.

Sample d_1 was made by adding drop by drop to 1 liter of almost boiling sulphuric acid ($V=0.25$) 250 cc of the above mercurous nitrate solution, stirring continuously. The solution was kept hot by the aid of an electric stove. During the reaction, fumes of nitric acid were evolved. The product consisted of fairly large, pitted and irregular crystals, which were washed and preserved, as described above.

Sample d_2 was prepared by adding drop by drop 400 cc of the mercurous nitrate solution to a large excess of cold 1:4 sulphuric

³⁷ F. E. Smith: Electrician (Lond.), 55, 857; 1905.

acid continuously stirred with mercury in a large battery jar. The sample was then washed by decantation with acid of the same strength and preserved as described above. This is practically Smith's method *b*.³⁸ In both cases the stirring was continued over night to facilitate the reduction of any mercuric salt present.

(*e*) *By the action of dilute sulphuric acid, containing a small amount of nitric acid, on mercury.*—Six samples were made by this method, in which the preparation of mercurous nitrate is avoided. The reaction which takes place is that involved in the Lunge method for the estimation of nitrates, so that the nitric acid is almost completely eliminated from the solution.

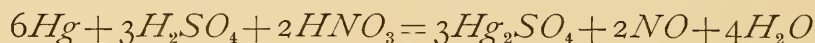

The rate of the reaction depends on the concentration of the sulphuric acid, the amount of nitric acid present, and the temperature. The mercury is contained in a beaker and covered with sulphuric acid, the nitric acid added, and the whole stirred vigorously and continuously for some time after the disappearance of brown fumes of nitrogen peroxide. The product formed is quite gray from the presence of finely divided mercury, and after washing several times by decantation with 1:6 sulphuric acid it should be transferred to a glass-stoppered bottle with some of the acid. The conditions under which the various samples were formed are as follows:

Sample *e*₁ was obtained by vigorously stirring a solution consisting of 600 cc sulphuric acid (*V*=0.25) and 20 cc concentrated nitric acid with a considerable volume of pure mercury. After a few minutes, before starting the stirring, the mercurous sulphate began to separate out at the surface of the mercury. The beaker was then heated and the stirring begun. Shortly afterwards fumes of nitrogen peroxide began to appear, gradually increasing in volume, and finally disappearing. The heating and stirring were continued for an hour. The product, which settled rapidly, was in grayish aggregates of fairly regular crystals, as seen under the microscope.

³⁸ For the preparation of mercurous nitrate Smith recommends adding nitric acid until all the mercury has gone into solution. This is inadvisable owing to the formation of more or less mercuric nitrate. He also recommends that only enough mercurous nitrate solution to neutralize 30 per cent of the sulphuric acid should be added.

Sample e_2 was prepared at room temperature in a similar manner with a mixture of 800 cc 1:4 sulphuric acid and 10 cc nitric acid. The action was very much slower. No crystals appeared in two hours. The stirring was continued for thirty-six hours and a voluminous precipitate of fairly good crystals was obtained.

Sample e_3 was obtained at room temperature with 600 cc 1:2 sulphuric acid and 10 cc concentrated nitric acid. The action was much more rapid than in the previous case.

Sample e_4 was prepared by adding to 600 cc 1:4 sulphuric acid, previously heated almost to boiling, 2 cc concentrated nitric acid. There was no visible action after one hour, even after adding a small quantity of electrolytically prepared mercurous sulphate. On interrupting the stirring, however, the formation of the mercurous sulphate and nitrogen peroxide began almost immediately.

Sample e_5 was prepared in a similar manner, using 750 cc 1:4 sulphuric acid and 2 cc nitric acid. Crystals very irregular.

Sample e_6 was prepared in the same manner as the previous sample except that the solution was not heated and twice the quantity of nitric acid was used. The action was very slow in starting so that after waiting a considerable time the formation was started electrolytically by a current of 2 amperes for less than two minutes. The crystals were also very irregular.

Samples e_1 , e_2 , and e_3 were tested for nitric acid by brucine. The sulphuric acid in which the samples were prepared gave a mere trace for sample e_1 , a small quantity for sample e_2 , and a considerable quantity in sample e_3 , the latter two being prepared in the cold. The mercurous sulphate samples showed only mere traces of nitrate.

The same samples and the filtrates were also tested for ammonia by means of Nessler's solution, but the results were negative.

(f) *By reduction of mercuric sulphate by metallic mercury.*—Mercuric sulphate was prepared by adding 150 grams of pure mercury to 350 cc concentrated sulphuric acid, previously heated approximately to the boiling point. The heating was continued for some time after all the mercury had been dissolved, and the white product dissolved in 2.5 liters of 1:6 sulphuric acid, the solution remaining perfectly clear.

Sample f_1 was prepared by vigorously stirring 400 cc of the above solution, further diluted to about 2 liters with 1:6 sulphuric acid, with metallic mercury. The product formed was quite dark. The stirring was continued over night, and in the morning the acid showed no trace of mercuric sulphate.

Sample f_2 was prepared in a similar manner with 100 cc of the mercuric sulphate solution diluted with nine times its volume of a solution of sulphuric acid containing 200 grams per liter. After the action seemed completed an additional 100 cc of the mercuric sulphate solution was added and the stirring continued over night. No mercuric sulphate was found in the solution.

(g) *By reduction of mercuric sulphate with sulphurous acid.*—A considerable number of experiments were made under varying conditions on the action of sulphurous acid on mercuric sulphate. In most cases an approximately saturated solution of sulphurous acid, diluted with sulphuric acid and water so that the concentration of the sulphuric acid was at least 1:6, was introduced drop by drop into a similarly diluted mercuric sulphate solution and vigorously stirred. After some time the solution would become cloudy from the formation of mercurous sulphate and on interrupting the stirring the white product would collect at the bottom of the beaker. On the further addition of H_2SO_3 the product would become gray. The crystals obtained were usually quite large and fairly good. Very different results were obtained by mixing the solutions quickly, the crystals being in the form of irregular plates; sometimes feathery or large prismatic crystals were obtained. They appeared cloudy when examined under the microscope. An excess of sulphurous acid should be avoided to prevent the further reduction to metallic mercury.

Sample g_1 was obtained by adding drop by drop a dilute solution of sulphurous acid in 1:6 sulphuric acid, to a similarly diluted solution of mercuric sulphate, previously heated and continuously stirred. The heating was continued for some hours and the stirring over night. The crystals formed were white and fairly regular.

Sample g_2 was prepared in a similar manner, but without heating the solution. The crystals obtained were white, but much channeled.

Sample g_3 . Twenty-five grams of chemically pure mercuric sulphate were dissolved in one liter of 1:6 sulphuric acid and reduced by means of a slow current of sulphur dioxide, mixed with air, the solution being kept at 80° . It was then digested in a covered beaker for two days at the same temperature.

METHODS OF TREATMENT OF COMMERCIAL SAMPLES.

In the earlier stages of the work efforts were made to obtain the mercurous sulphate in the form of perfect crystals. It was first noticed that the character of commercial samples was very considerably modified by digesting them with 1:6 sulphuric acid on the steam bath. The commercial samples were very fine-grained, and when examined under the microscope showed hardly any regular crystalline structure with the magnification employed, while, after digesting, crystals of considerable size and some regularity were obtained. This suggested the possibility of obtaining perfect crystals by slow recrystallization from strong sulphuric acid. On slowly cooling long crystals of an acid sulphate were formed, which became whitish and opaque when treated with water, alcohol, anhydrous ether or even concentrated sulphuric acid, after they had been filtered by suction. When the solution was rapidly cooled fairly good crystals began to separate out when the solution was still quite warm.

Experiments were next made to precipitate the mercurous sulphate from its solution in strong sulphuric acid by gradual dilution with sulphuric acid of various concentrations not less than 1:6.

(*h*) *By crystallization from strong sulphuric acid.*—Sample h_1 was prepared as follows:

Concentrated sulphuric acid was heated to 150° and an excess of commercial mercurous sulphate added. Three hundred cc of the cloudy liquid was transferred to a beaker and stirred. It did not clear on adding fuming sulphuric acid. Three hundred cc of 1:2 sulphuric acid was added drop by drop. Then about 200 cc of 1:3 and finally 500 cc of 1:6 sulphuric acid were added in the same manner. The precipitated mercurous sulphate was in comparatively large crystals, which were, however, much channeled.

The warm mother liquor was decanted and divided into equal portions. To one was added an equal volume of hot water. Both

lots yielded crystals on cooling, those from the diluted portion being very perfect.

Sample h_2 was prepared by dissolving 50 grams of Kahlbaum mercurous sulphate in 250 cc of concentrated sulphuric acid previously heated to 150° . To the clear liquid was added an excess of mercury and 300 cc concentrated sulphuric acid. This was diluted by adding drop by drop 600 cc 1:2, 300 cc 1:3, and finally 1,500 cc 1:6 acid. After all the dilute acid had been introduced, it was rapidly cooled to room temperature, the mother-liquor decanted, and the mercurous sulphate washed twice with 1:6 sulphuric acid.

(h_3) Smith³⁹ has also described a method for preparing mercurous sulphate by recrystallization from sulphuric acid. This sample was made by closely following his specifications. Chemically pure mercurous sulphate as purchased was warmed in a covered evaporating dish with pure concentrated sulphuric acid and a small quantity of mercury to a temperature of about 150° for about ten minutes, the mixture being kept well stirred. After settling, the clear solution was poured into 1:6 sulphuric acid, when crystalline mercurous sulphate separated out. About ten times the bulk of dilute acid was employed and, to avoid spitting, the hot liquid was poured through a funnel having its stem immersed in the dilute acid. The mixture was well stirred, and after cooling the sulphuric acid was decanted and the mercurous sulphate was transferred to a glass-stoppered bottle.

(i, k, l, m, n) *By digestion with sulphuric acid.*—Sample i_1 was prepared by heating mercurous sulphate (Kahlbaum B) with mercury and concentrated sulphuric acid to 150° for some hours. Compact crystals were obtained when the solution was rapidly cooled.

Sample i_2 was one of a large number prepared by heating mercurous sulphate (Kahlbaum B) with strong sulphuric acid.

Further experiments were made to study the influence of digesting commercial samples of mercurous sulphate with dilute sulphuric acid under various conditions. Six samples purchased as chemically pure were available. Three of these were obtained from Kahlbaum at different times and the others from Merck, Schuchardt, and Gehe. Twenty-five grams of each of these six samples were digested with

³⁹F. E. Smith: Electrician (Lond.), 55, p. 857; 1905.

hot 1:4 sulphuric acid and mercury in March, 1906. The samples were ground in an agate mortar with the acid and transferred to a 1.5-liter beaker and vigorously stirred and heated to about 90° for several hours. The stirring was continued until the next morning. The Merck sample at first showed a decidedly yellowish color which disappeared during the night except above the level of the liquid.

In some cases the beakers were sheathed with asbestos and covered with watch glasses to reduce the formation of the yellow incrustation due to the condensation of water on the sides of the beaker and its action on the mercurous sulphate. The effect was further reduced in one case by blowing air into the beaker through a hole in the cover glass to prevent condensation, and by increasing the speed of the stirrer from time to time to sweep back any mercurous sulphate into the body of the liquid.

In the tables below these samples are designated as follows:

Source	Designation
Kahlbaum A	k ₁
Kahlbaum B	k ₂
Kahlbaum C	k ₃
Merck	k ₄
Schuchardt	k ₅
Gehe	k ₆

Five of the commercial samples were digested with 25 per cent sulphuric acid and four of them with 10 per cent acid since April, 1904. All six samples were digested with 1:6 acid and mercury since October, 1905, the bottles being shaken from time to time. In the table below these samples are designated as follows:

Treatment and Designation.

Sample	25% acid	10% acid	1:6 acid
Kahlbaum A	1 ₁	m ₁	n ₁
Kahlbaum B	1 ₂	--	n ₂
Kahlbaum C	--	--	n ₃
Merck	1 ₃	m ₂	n ₄
Schuchardt	1 ₄	m ₃	n ₅
Gehe	1 ₅	m ₄	n ₆

Samples 1₁ to 1₅ were vigorously stirred (April, 1906) with mercury and acid for twenty-four hours and then preserved in bottles with mercury.

The paste.—This was always freshly prepared before setting up the cells. It is obvious from the irregular pitted character of the mercurous sulphate crystals, as shown under the microscope, that the greatest care must be taken in washing the sample to completely remove all traces of acid. This was done in a platinum Gooch crucible with a disk of hardened filter paper at the bottom. These disks were cut to size with a cork borer, warmed for some time with dilute nitric acid, washed until acid-free with hot distilled water and dried. A sufficient quantity of the mercurous sulphate, shaken up with the acid under which it was preserved, was poured into the crucible, care being taken not to transfer any of the mercury which interferes with the washing, the acid removed by suction, and the salt washed twice with small portions of 1:6 sulphuric acid to remove possible traces of mercuric sulphate formed by the action of air on particles of mercurous sulphate not covered by the acid. The acid was removed by the addition of 5 or 6 portions of redistilled absolute alcohol, care being taken to wash down the sides of the crucible. To completely remove the alcohol the sulphate was then washed three or four times with a saturated solution of zinc or cadmium sulphate, according to the type of cell to be set up, taking the same precautions as above. If the paste cracked or separated from the sides of the crucible more of the wash liquid was added and the contents of the crucible thoroughly stirred up before again applying suction. After scraping off the upper layer the mercurous sulphate was transferred to a small, clean, dry beaker, or crucible, mixed with one-third to one-half its volume of finely powdered zinc or cadmium sulphate crystals and sufficient saturated zinc or cadmium sulphate solution to make a moderately thin paste. A large excess of zinc or cadmium sulphate crystals in the paste should be avoided so that practically every part of the mercury surface will be in contact with the mercurous sulphate, thus securing the rapid attainment of saturation equilibrium. With white samples of mercurous sulphate, one-third the volume of mercury was added with the crystals of zinc or cadmium sulphate in making up the paste. To eliminate possible influence of size of grain the paste was stirred as little as possible in its preparation.

THE CELLS.

For facility in filling and sealing the H type was adopted. The size and dimensions, although not affecting the electromotive force determine the polarization produced by the passage of a current and the rapidity with which the cell assumes the temperature of its surroundings. Figure 3, drawn to half scale, gives the approximate dimensions of the cells used at the Bureau. Especial care was taken in sealing in the platinum wires and subsequent annealing. As recommended by Hulett, the platinum wire inside the cell was covered in most cases with a thin layer of glass to within 1 mm or

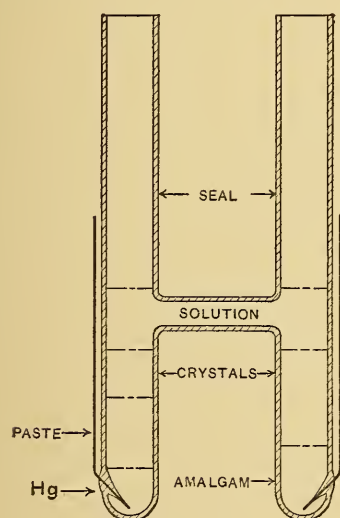

Fig. 3.

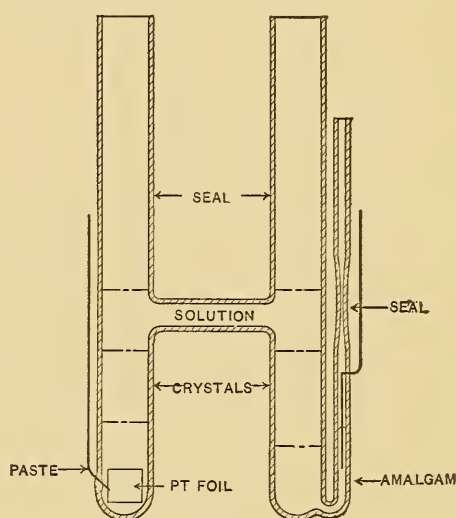

Fig. 4.

Sectional Views of Standard Cells (Half size).

less from the end. The wire should not be larger than B. & S. No. 28, to reduce the liability of cracking. No. 32 was used in most of our cells.

The Clark cells nevertheless frequently cracked at the point where the platinum terminal was sealed into the amalgam limb. This may be avoided by a construction recommended by the Reichsanstalt and shown in figure 4, in which the platinum terminal of the amalgam limb is sealed into a side tube while the amalgam is still liquid, contact being made by sucking the amalgam up into this tube. The platinum wire extends downward about 2 cm below the

point at which it is sealed into the tube and the amalgam should cover only its lower half, thus preventing the glass from cracking at the seal. This construction also reduces the chance of contact between the platinum and the electrolyte, and for this reason is preferable for portable cells. This form was adopted, for Clark cells, in our later work.

As the cells are to be sealed off above the cross arm after filling, they may be slightly constricted beforehand, but if the wall thickness is not greater than 0.75 mm, as was the case with our cells, this is not necessary. The length of the tube above the cross arm as shown in figures 3 and 4, although greater than absolutely necessary, facilitates the sealing but at the same time somewhat increases the difficulty of filling.

Cleaning the cell.—The cells and filling tubes when badly contaminated with grease, etc., were covered with chromic acid mixture and allowed to stand overnight. Longer contact with this cleaning mixture was avoided on account of the danger of forming lead chromate from the lead sealing-in glass employed.⁴⁰ The cells were then washed with distilled water, filled with aqua regia, which was allowed to remain in them for thirty minutes, and repeatedly washed with distilled water. The action of the aqua regia on the platinum wires facilitated subsequent amalgamation. Ordinarily the cleaning with chromic acid mixture could be omitted.

Amalgamation of the platinum terminals.—In order to minimize the possibility of contact between the electrolyte and the platinum terminals, especially from shaking in transport, they were amalgamated with a solution of pure mercurous nitrate in dilute nitric acid. The amalgamating solution was introduced into the cell and a weak current passed through it from a platinum wire anode to the platinum terminal externally connected to the negative pole of a battery. Sufficient mercury was deposited in a few minutes. In a type of portable cell to be described later, the limb intended to receive the paste was provided with a platinum foil electrode welded to the platinum wire. (Fig. 4.) In this case the whole surface was

⁴⁰ This was observed in one lot of cells that had been overlooked and had been left in the cleaning fluid for several weeks. The chromate was not removed by treatment for several days with nitric acid or aqua regia.

thoroughly amalgamated, for which a proportionately longer time was required. Especial care was taken as the amalgamated foil was employed to replace the mercury.

To remove every trace of the amalgamating solution the cell was next washed several times with dilute nitric acid, and finally repeatedly rinsed with distilled water. The amalgamated surface was usually "rinsed" with a small quantity of pure mercury, the cell then dried in an air bath at 110° .

Introduction of the materials.—The materials were easily and neatly introduced by means of filling tubes, care being taken not to allow the latter to come in contact with the walls of the cell.

The amalgam.—The zinc or cadmium amalgam, prepared as described above, was heated slightly above its melting point and a quantity of it sufficient to cover the platinum terminal to a depth of at least 10 mm transferred to the cell by means of a previously heated, clean, dry pipette. A pipette with a rounded end, at the center of which is a small hole, was found more satisfactory than one drawn out to a capillary, which the amalgam tended to clog up owing to cooling. After heating the pipette, which was provided at the upper end with a rubber tube, it was introduced below the surface of the amalgam, meanwhile blowing through it, to avoid the introduction of any oxide formed on the surface. A suitable amount of amalgam was then drawn into the pipette by gentle suction, which was released while the pipette was withdrawn, and then applied again sufficiently to prevent any more of the amalgam from running out. Particles of the amalgam adhering to the outside were then removed by wiping with filter paper and the pipette introduced into the cell to within 2 cm of the bottom. On releasing the suction the amalgam ran out freely, the amount introduced being regulated by again applying suction at the proper moment. The pipette was then withdrawn without touching the walls of the cell. In our earlier work a thin glass tube of slightly less diameter than the cell was used to protect the walls but after some practice this was found to be unnecessary.

Particles of amalgam which in spite of precautions occasionally adhered to the cell wall, and which could not exert any influence on

the electromotive force except when forming an integral part of the amalgam electrode and not fully covered with crystals, were removed by the aid of a glass rod. Great care was taken to prevent them from reaching the other limb and contaminating the mercury, which would of course seriously influence the electromotive force.

Introduction of the mercury.—At first the mercury was introduced by means of a pipette drawn out to a very fine capillary, but later a sufficient quantity to cover the platinum terminal to a depth of least 10 mm was simply poured into the cell, care being taken not to introduce any into the amalgam limb. By cautiously tilting the cell, air bubbles entrapped under the mercury could easily be removed.

Introduction of the paste.—The paste, prepared immediately before setting up the cell as described above, was introduced by means of a pipette with an opening 3 to 4 mm in diameter. Its consistency was such that it could readily be drawn up into and flow from the pipette; and therefore finely crushed zinc sulphate or cadmium sulphate crystals were employed. After filling the pipette with paste it was wiped with clean filter paper, and a small amount of the paste allowed to flow out. The end of the pipette was then brought close to the mercury and paste allowed to flow into the limb, to a depth of 1.5 to 2 cm, except in the cells first set up, care being taken to keep the walls of the cell clean and to avoid trapping air bubbles.

Introduction of the crystals and solution.—The amalgam and paste were next covered to a depth of about 1 cm with *saturated* zinc sulphate or cadmium sulphate solution, after which pulverized zinc sulphate or cadmium sulphate was introduced—a little at a time to avoid trapping air bubbles—to a depth of 1.5 to 2 cm by means of a wide-stemmed funnel. The cell was then filled slightly above the cross arm with *saturated* zinc sulphate or cadmium sulphate solution.

In order to maintain a concentration equilibrium at all temperatures to which the cell was likely to be exposed, a saturated solution of zinc or cadmium sulphate and a sufficient excess of the corresponding crystals over the amalgam and in the paste were employed. The layer of crystals in the mercury limb was intended as a further

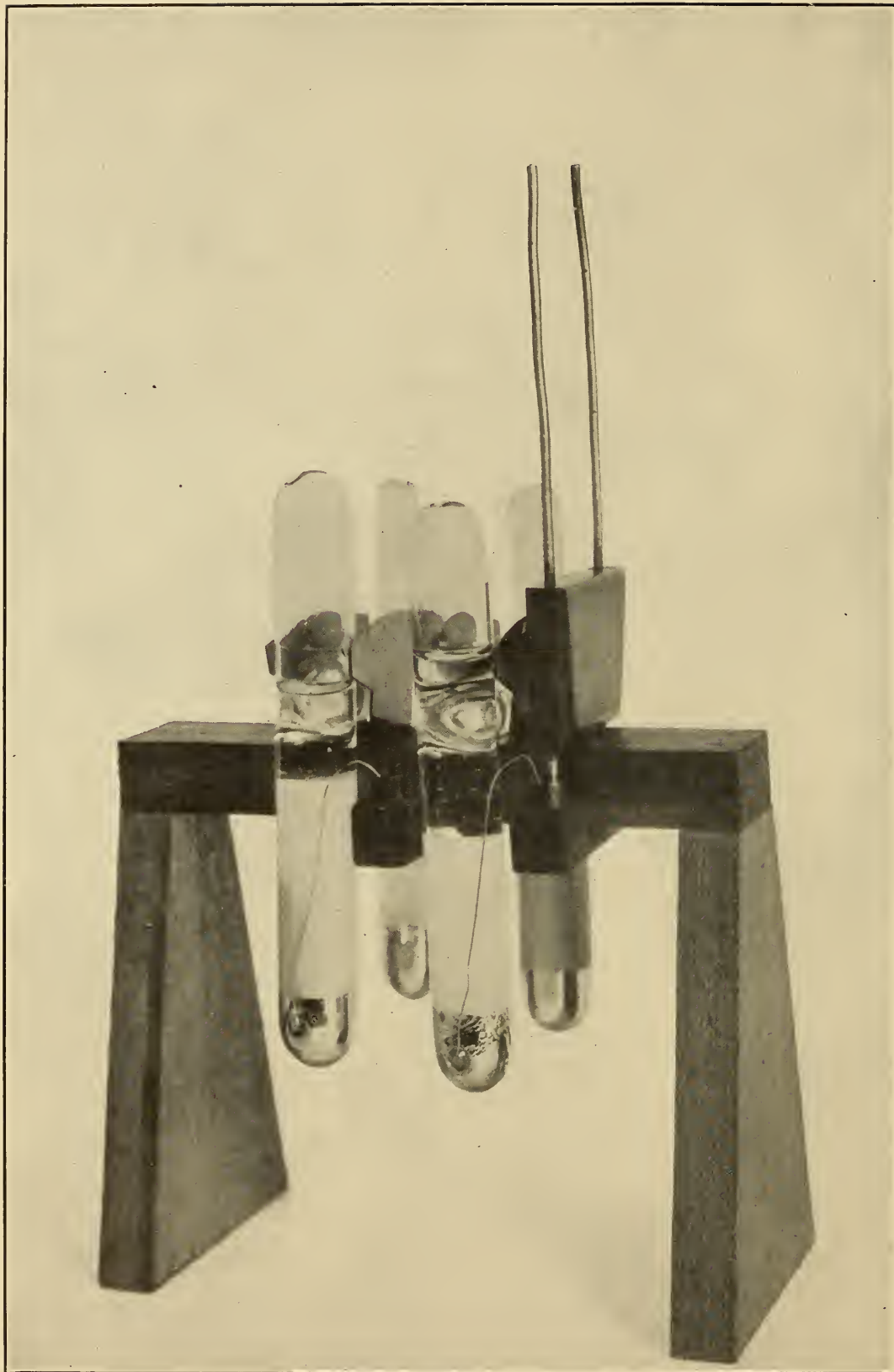

Fig. 5.—*Finished Cells showing Traveling Contacts and Method of Mounting.*

precaution against their leaching out of the paste, which may happen when the solution is not completely saturated.

*Sealing.*⁴¹—The cell was next hermetically sealed by the aid of two small horizontal blow-pipe flames applied to the cell wall from opposite directions. One limb of the cell was closed by a cork and the other by a cork nicked at one side, through which passed a glass rod to serve as a handle in drawing it out. The cell was gradually heated 2 to 3 cm above the level of the liquid, until the danger of cracking had passed, and then held in the flame, rotating meanwhile, until the tube almost collapsed, after which it was closed by drawing it out slowly while still in the flame. By judicious heating the seal could be nicely rounded by the expansion of the inclosed air. The second limb was sealed in a similar manner. The finished cell is shown in figure 5. Whenever, in filling the cell, the materials accidentally came in contact with the cell wall above the cross arm, where it was to be heated in sealing, it was cleaned by first wiping with filter paper slightly moistened with distilled water and then with dry paper.

THE COMPARING BATHS.

The relatively large temperature coefficient of the Clark cells made it necessary to provide for automatically regulating their temperature to within 0.01° . With old cells this regulation must be maintained for twenty-four hours or more previous to measurements, on account of the hysteresis frequently observed. All comparisons were therefore made in electrically heated and controlled kerosene baths.

The baths, 70 cm in diameter and 40 cm deep, were set up in a room in the basement of the laboratory, the temperature of which was automatically controlled to within 1° to 2° for most of the year

⁴¹Wright and Thompson: *Phil. Mag.* (5), **16**, p. 28; 1883.

Kahle: *Zs. f. Instrk.*, **13**, p. 298; 1893.

Callendar and Barnes: *Proc. Roy. Soc.*, **62**, p. 117; 1897.

Barnes: *Phys. Rev.*, **10**, p. 268; 1900.

Carhart and Hulett: *Trans. Am. Electrochem. Soc.*, **5**, p. 67; 1904.

by means of a thermostat pneumatically operating dampers in the hot and tempered air supply ducts. As there were no windows, the cells were also protected against any possible influence of direct or even diffused sun light.

The construction of the thermoregulator employed in the baths, although not embodying any essentially new features, is described

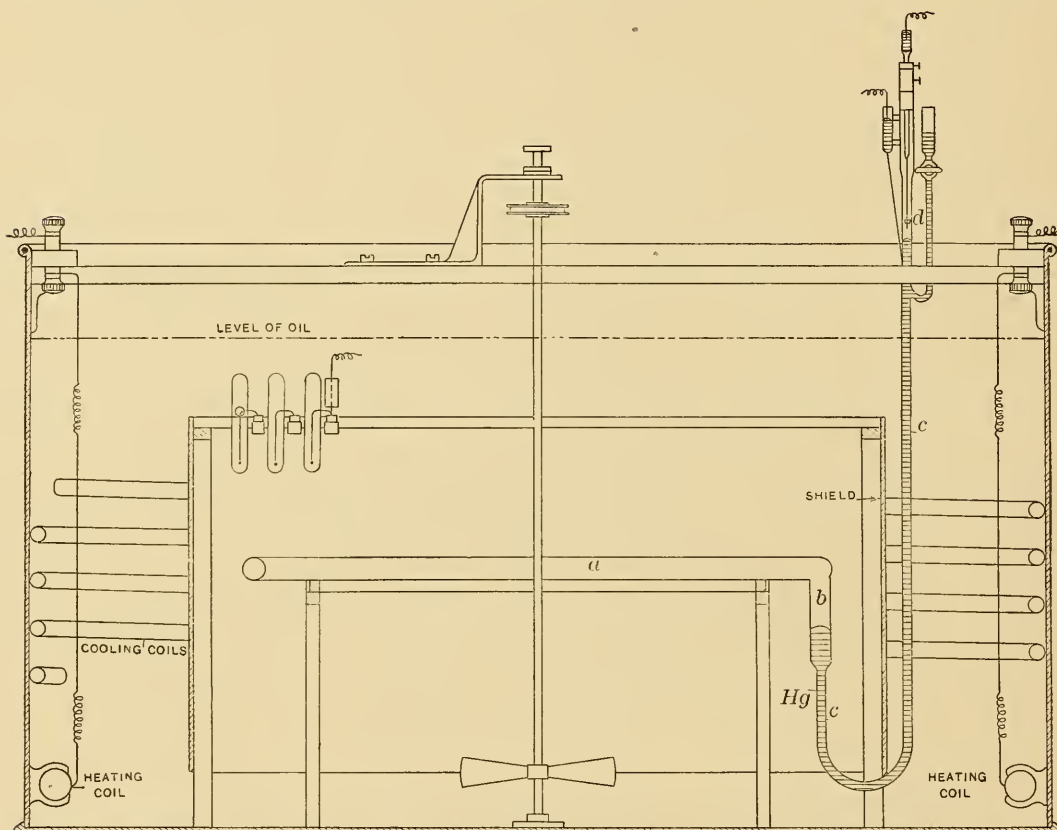

Fig. 6.—Comparing bath (sectional view).

rather fully below for the convenience of others who may wish to undertake standard cell work.

It consists of a reservoir in the form of a horizontal grid made of thin-walled glass tubing, 1.5 to 2 cm in diameter, containing the thermometric substance (toluene), the volume changes being transmitted by a U-shaped connecting tube, *c*, filled with mercury to a vertical capillary, *d*. (Figs. 6 and 7.) The reservoir, *a*, is provided with a downward extension, *b*, to allow for expansion and contraction of the toluene when the regulator is used at widely differing

temperatures, thus preventing the toluene from reaching the capillary. In filling, all air must be removed to eliminate the influence of variations in atmospheric pressure on the regulation. The capillary, *d*, 1 to 2 mm in diameter, is fused to a wider tube, *e* (fig. 7), to the upper end of which is cemented a bushing, *f*, fitting loosely enough to allow for the cement. The steel pin, *g*, with its upper end hollowed out to serve as a mercury cup, and passing through *f*, is fixed in position by the set screw, *h*, and has soldered to its long end a fine-pointed platinum wire, *i*. Five millimeters from the free end of the wire is fused a glass bead, *k*, to facilitate centering, but fitting the capillary loosely enough to permit the ready passage of mercury in either direction. It is advisable to have on the rod, *g*, a small steel collar, *p*, provided with a set screw to facilitate resetting after cleaning the capillary, which must be done occasionally. One end of a second platinum wire, *l*, is fused into the tube, *c*, below the capillary, and the other end into a small glass tube, *m*, attached to *e* by two short glass rods, and serving as a terminal cup.

The side tube, *n*, connected to *c*, as shown, to avoid trapping air bubbles when for any reason the bath may be allowed to cool considerably, is provided with a well-fitting stop-cock communicating with the small mercury reservoir, *o*.

The bath is brought approximately to the temperature at which it is to be regulated and sufficient mercury admitted or withdrawn (by gentle suction applied by means of a rubber tube) so as to bring the mercury level near the middle of the capillary. The pin, *g*, is then adjusted so as to make contact with the mercury when the desired temperature is reached, thus energizing a 50-ohm relay and increasing the external resistance in series with

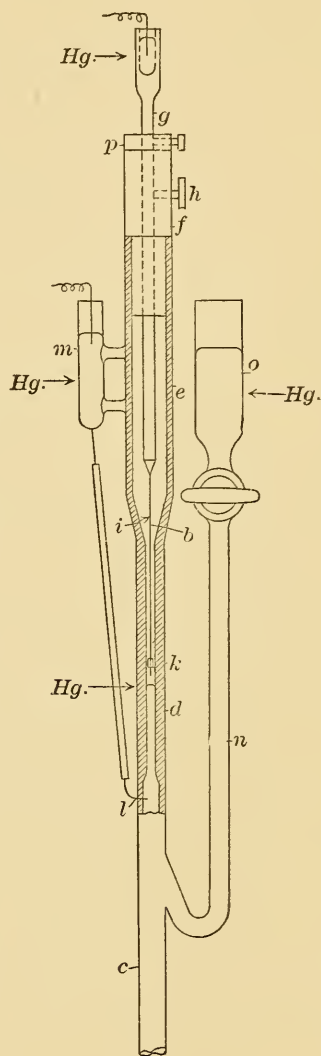

Fig. 7.—Thermoregulator.

the heating coils in the bath. Although the measurements here dealt with were all made at 25° , supplementary cooling had to be provided during the summer months, heat being abstracted by means of water circulation through a copper coil in the bath. The inlet and outlet of the coil were below the surface of the oil to prevent condensed moisture from getting into the bath. The flow of water was regulated so that somewhat more than enough cooling was effected, the difference being made up by electric heating. Owing to the variable temperature of the tap water, it was first passed through a coil in an ice chest.

In two of the baths the heating coils (Figs. 6 and 8) consist of four Ward-Leonard rheostat units, of advance wire wound in enamel on fire-clay tubes. These were mounted one in each quadrant by metal clips attached to the walls of the tank, external to the space occupied by the cells. In the third bath a grid built up of glass rods wound with bare advance wire and then shellacked was employed. With a 110-volt supply, a resistance of 80 to 125 ohms provided ample heating.

The external resistance, and if necessary the supplementary ice-water circulation, were adjusted so as to maintain the bath about 2° below the desired temperature, so that the additional heat supply required to produce regulation was as small as consistent with variations called for by changes in the room temperature, the effect of which was considerably reduced by covering the baths externally with sheet asbestos.

A most convenient and inexpensive form of rheostat, where a supply of incandescent lamps of various candlepowers is available, is shown in figure 8. The lamps in the two lower sockets determine the external resistance during the cooling period. When the relay circuit is open all the lamps are in parallel.

Stirring.—Uniformity of temperature throughout the bath was secured by an efficient centrally located stirrer producing an upward and rotary circulation. In addition the rectangular stand on which the cells were mounted was provided with a sheet metal shield extending to within 4 cm of the bottom of the bath (Fig. 6), thus directing the circulation and in addition protecting the cells from the direct influence of the cooling coil, and also in two of the tanks from the heating coils. Measurements made by a platinum ther-

mometer showed that the temperature of the space occupied by the cells was everywhere uniform to well within 0.01° , so that it was

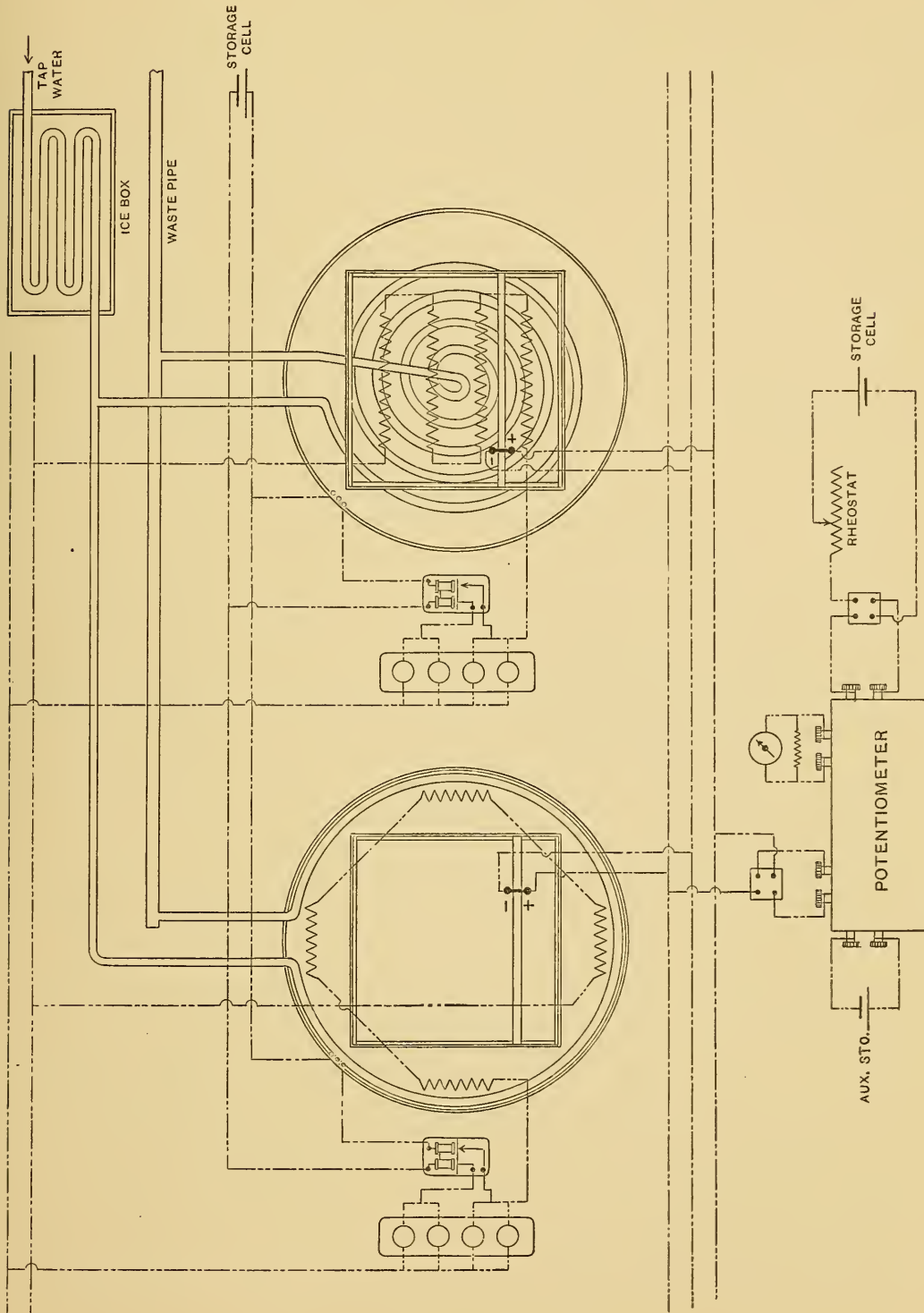

Fig. 8.—Plan View of Comparing Baths and Diagram of Connections.

hardly necessary to employ a grid thermoregulator to integrate the temperature of the bath.

The temperature variation during regulation is of course determined primarily by the volume and differential cubical expansion of the liquid employed in the thermostat and the diameter of the capillary. It is influenced, also, by temperature lag in the regulator and in the heating coils and by any contamination of the mercury surface at which contact is made. The lag is reduced by the form of regulator employed and by a proper adjustment of the external resistance, so that a minimum increase in the heating current is required for regulation.

The actual range can be calculated as follows:

Let W_1 = rate of heat loss in watts during cooling period

W_2 = added heating in watts for regulation

t_1 = cooling period in seconds

t_2 = heating " " "

Then

$$W_1 t_1 = (W_2 - W_1) t_2,$$

or

$$W_1 = W_2 \frac{t_2}{t_1 + t_2}.$$

Hence W_1 can be calculated.

The total heat loss in joules during the cooling period or gain during the heating period will therefore be

$$W_1 t_1 = W_2 \frac{t_1 t_2}{t_1 + t_2}.$$

The temperature range may then be found by dividing this quantity by the calculated heat capacity of the bath expressed in the same units.

The results thus arrived at are in good agreement with direct measurements with a platinum thermometer.

The cells were mounted (Figs. 6 and 8) on six parallel wooden strips, each accommodating 18, and held in place by sheet metal clips. The strips were supported by a metal framework, so that the electrodes of the cells were 25 cm above the bottom of the tank and 3 or 4 cm above the level of the grid of the thermoregulator. The cells were covered to a depth of at least 2 cm with high-grade kerosene.

Between the cells were mounted hard rubber blocks, each carrying two short copper rods, provided with a pair of holes for mercury

cups, one for a cell terminal and the other for external connections. The holes for the latter purpose were spaced at the same distance apart, so that any cell could be put in circuit by inserting a pair of stiff contact wires mounted on a hard rubber block. (Fig. 5.) This method was preferred on account of possible leakage troubles which might arise by connecting together all the positive or negative terminals and to facilitate the comparison of any number of cells in series.

Connections to the potentiometer were made by the aid of three insulated line wires extending over the baths and to which the leads from the contact wires and the potentiometer terminals could be connected in any desired manner by the aid of metal clips. (Fig. 8.) By this means the measurements were so greatly facilitated that the cells could easily be compared to parts per million at the rate of 100 per hour.

THE ELECTRICAL MEASUREMENTS.

The measurements given below were all made by means of a 5-dial Wolff potentiometer of the usual construction having a resistance of 10,000 ohms per volt, the units of the tenth ohm dial corresponding therefore to 10 microvolts. The potentiometer current was furnished by a storage cell of ample capacity, which was continuously left in circuit and covered with sheet asbestos to reduce temperature variations. Under these conditions the current, regulated by a manganin rheostat, was sufficiently constant for all purposes.

A high sensibility D'Arsonval galvanometer, made by the Weston Electrical Instrument Company, was employed throughout. A difference of 10 microvolts produced a deflection of at least 1 mm, so that the values could be readily measured to microvolts, even with the high resistance potentiometer employed.

The comparison of cells of the same type was made by the differential method, each cell being measured in opposition to one of the lot taken as a standard of reference. As the differences measured were small, no errors are introduced by possible variations of the potentiometer current likely to occur during a complete set of measurements. From the differences thus measured the results could be expressed in terms of any particular cell or the mean value of a

number by applying a suitable correction. This method has an additional advantage, particularly with Clark cells when in the same bath, as all vary simultaneously by an approximately equal amount with the minor temperature variations during regulation.

As a further check on the constancy of both the Clark and Weston cells their ratio was determined from time to time, both by the direct method in which a number of the cells of each type were separately measured and by the differential method in which the difference between series of five Clark and seven Weston cells was determined. The differential method had the advantage that the potentiometer corrections became almost negligible, as did also errors due to variations in the potentiometer current. In addition, it was practicable to determine the average difference during a complete cycle of regulation. The result thus obtained gives the mean ratio of the cells concerned.

Temperature measurements.—The influence of errors in measuring the temperature enters only in determining the value of the Weston in terms of the Clark cell, as in most of the work all the Clark cells were in the same bath.

The accuracy required in the temperature measurements is determined by the temperature coefficient of the Clark cell, almost one-tenth per cent per degree, corresponding to 0.01° where an accuracy of one part in 100,000 is sought. Mercury thermometers standardized at the Bureau were employed throughout; some checks have, however, been made by a platinum thermometer. In the earlier stages of the work less care was devoted to the determination of the Clark-Weston ratio, as new cells of both types were being constantly set up, and a single thermometer was used. In a redetermination of the temperature coefficients shortly to be made both mercury and platinum resistance thermometers will be employed.

Other possible sources of error.—The corrections of the potentiometer employed were determined from time to time to an accuracy of at least 1 part in 100,000. The close agreement of the values of Weston in terms of Clark cells obtained by the direct and differential methods (Table XVI) shows that no errors larger than the above amount can be thus introduced. The agreement also shows no appreciable errors are introduced by defective insulation which would affect the terminal potentials measured unequally. Measurements were, however, made of all insulation resistances, including

the resistance between cell terminals in the bath on a blank cell with the cross arm sealed off, but in every case the resistances were found to be so large as not to introduce an error as great as 1 part in 100,000 in the results. This was surprising, since the oil in two of the baths had been contaminated by the breakage of cells.

Thermoelectromotive forces, always very small, were eliminated in the usual manner by a simultaneous reversal of the potentiometer current and the connections of the cell circuit. The very small variations in the potentiometer current, not affecting the measurement of the differences between cells of the same type and in the differential method were practically eliminated in the direct comparison of Clark and Weston cells by a repetition of the observations in reverse order. The possible influence of hysteresis was practically eliminated by very close regulation of the baths.

TABULATION OF RESULTS.

The following tables give the results of a few of the numerous series of measurements on cells set up to test the electromotive properties of mercurous sulphate. A considerable number of other cells have been constructed for testing the other materials, different methods of washing the mercurous sulphate, influence of depth of paste, size of grain, and other possible causes of variation. A discussion of the results obtained, together with a study of the influence of added impurities, will be reserved for a later paper, as the mercurous sulphate has been found mainly, if not entirely, responsible for the variations observed.

In Tables III to XV, below, the first column gives the number of the cell, the second the date of setting up, the third the designation of the mercurous sulphate employed, the letter indicating the method of preparation and the subscript the number of the sample (see text); column four shows which lot of cadmium or zinc sulphate was employed, and column five gives similar information in regard to the amalgams. In the remaining columns are given the differences in microvolts between the individual cells and the mean of a number arbitrarily selected as a basis of reference.⁴² The three undated columns, marked *, **, and *** give the differences within one, two, and seven days, respectively, after the date of setting up the cells.

⁴² Weston cells Nos. 1, 2, 3, 4, 5, 6, 8, 9, 11, 12, 14, and 15, and Clark cells Nos. 27a, 28, 32, 34, and 39, data for which are given in heavy type in the tables.

TABLE III.

Weston Cells.—Electrolytic Mercurous Sulphate made with Old Apparatus.

[Differences in Microvolts from Mean of Reference Cells.]

Cell	Date	Mer- curous sul- phate	CdSO ₄	Cd Amal- gam	*	**	***	July 5, 1906	July 20	Aug. 4	Aug. 21
75	June 26, '06	a ₁	a ₁	b	+ 86	+ 77	+ 56	+ 57	+ 54	+ 47	+ 39
76	"	a ₄	a ₁	b	+ 61	+ 56	+ 41	+ 39	+ 35	+ 34	+ 33
64	June 25, '06	a ₅	a ₁	b	+109	+106	+ 87	+ 92	+ 84	+ 78	+ 81
65	"	a ₆	a ₁	b	+ 87	+ 83	+ 66	+ 67	+ 63	+ 58	+ 55
8	May 16, '06	a ₇	a ₁	b	+13	+12	+14	+13
40	May 9, '06	a ₇	a ₁	b	+102	+ 83	+ 74	+ 68
8a	June 28, '07	a ₇	a ₂	b	+147	+117	+107
66	June 25, '06	a' ₇	a ₁	b	+ 59	+ 55	+ 38	+ 39	+ 31	+ 32	+ 28
9	May 16, '06	a ₈	a ₁	b	- 9	- 8	- 6	- 7
41	May 9, '06	a ₈	a ₁	b	+ 68	+ 50	+ 45	+ 41
9a	June 28, '07	a ₈	a ₂	b	+ 47	+ 35	+ 31
67	June 25, '06	a' ₈	a ₁	b	+ 33	+ 34	+ 23	+ 26	+ 24	+ 25	+ 23
11	May 16, '06	a ₉	a ₁	b	+ 4	+ 4	+ 4	+ 4
42	May 9, '06	a ₉	a ₁	b	+ 48	+ 34	+ 30	+ 29
11a	June 28, '07	a ₉	a ₂	b	+ 68	+ 50	+ 46
68	June 25, '06	a ₁₀	a ₁	b	+ 26	+ 25	+ 11	+ 9	+ 9	+ 9	+ 7
70	June 26, '06	a' ₁₀	a ₁	b	+ 32	+ 29	+ 11	+ 14	+ 13	+ 8	+ 8
71	"	a ₁₁	a ₁	b	- 3	- 8	- 14	11	- 10	- 10	- 9
72	"	a' ₁₁	a ₁	b	- 1	- 5	- 9	- 6	0	- 3
73	"	a ₁₂	a ₁	b	+ 19	+ 13	+ 5	+ 9	+ 9	+ 4	+ 6
74	"	a ₁₃	a ₁	b	- 17	- 17	- 17	- 17	16	- 15	- 21

TABLE III.

Weston Cells. —Electrolytic Mercurous Sulphate made with Old Apparatus.

[Differences in Microvolts from Mean of Reference Cells.]

Cell	Sept. 13	Oct. 13	Nov. 2	Nov. 19	Dec. 1	Jan. 10, 1907	Mar. 1	Mar. 25	Apr. 24	May 24	June 26	July 23
75	+ 40	+ 29	+ 25	+ 21	+ 20	+ 11	+ 2	0	- 7	- 5	- 16	- 18
76	+ 27	+ 24	+ 19	+ 18	+ 16	+ 7	- 1	- 2	- 10	- 11	- 17	- 18
64	+ 73	+ 71	+ 68	+ 66	+ 62	+ 59	+ 50	+ 48	+ 41	+ 38	+ 32	+ 28
65	+ 40	+ 47	+ 46	+ 44	+ 43	+ 36	+ 38	+ 37	+ 34	+ 35	+ 31	+ 30
8	+ 12	+ 12	+ 11	+ 10	+ 12	+ 7	+ 11	+ 11	+ 9	+ 9	+ 8	+ 8
40	+ 65	+ 63	+ 56	+ 49	+ 46	+ 35	+ 24	+ 18	+ 10	+ 3	- 9	- 14
8a	+147	+ 65
66	+ 25	+ 24	+ 21	+ 22	+ 19	+ 18	+ 18	+ 19	+ 14	+ 14	+ 10	+ 10
9	+ 2	- 5	- 6	- 4	- 7	(-29) ¹
41	+ 44	+ 48	+ 47	+ 38	+ 36	+ 27	+ 33	+ 33	+ 30	+ 29	+ 22	+ 23
9a	+ 47	+ 15
67	+ 20	+ 20	+ 20	+ 20	+ 18	+ 16	+ 18	+ 15	+ 15	+ 14	+ 12	+ 15
11	+ 3	+ 3	+ 3	+ 2	+ 1	+ 2	+ 1	+ 3	+ 1	+ 2	0	0
42	+ 30	+ 33	+ 31	+ 25	+ 26	+ 24	+ 25	+ 25	(¹)
11a	+ 68	+ 23
68	+ 3	+ 2	- 1	- 3	- 6	- 9	- 13	- 16	- 17	- 19	- 19
70	+ 3	0	0	+ 1	- 3	- 4	- 7	- 7	- 9	- 7	- 9	- 11
71	- 11	- 11	- 10	- 10	- 10	- 13	- 14	- 12	- 16	- 15	- 17	- 15
72	- 5	- 6	- 9	- 10	- 14	- 13	- 13	- 15
73	+ 2	+ 3	+ 1	+ 2	+ 1	- 1	0	- 1	- 3	0	0	- 5
74	- 20	- 22	- 26	- 23	- 18	- 20	- 23	- 24	- 19	- 20	- 22	- 22

¹ Oil in cell; seal found defective.

TABLE IV.

Weston Cells.—Electrolytic Mercurous Sulphate made with New Apparatus.

Concentration of Sulphuric Acid exceeding Gram-Molecular.

[Differences in Microvolts from Mean of Reference Cells.]

Cell	Date	Mercurous sulphate	CdSO ₄	Cd Amalgam	*	**	***	July 5, 1906	July 20	Aug. 4	Aug. 21
26	May 9, '06	b ₁	a ₁	b	+ 24	+ 14	+ 12	+ 10
51	June 23, '06	b ₁	a ₁	b	- 6	- 8	- 12	- 10	- 10	- 9
27	May 9, '06	b ₂	a ₁	b	- 3	- 4	- 4	- 7
52	June 23, '06	b ₂	a ₁	b	+14	+28	+ 19	+ 14	+ 12	+ 9
28	May 9, '06	b ₃	a ₁	b	+ 35	+ 28	+ 22	+ 18
61	June 25, '06	b ₄	a ₁	b	+12	+12	+ 1	+ 4	+ 2	+ 1	+ 1
62	"	b ₅	a ₁	b	+ 7	+ 7	- 1	- 1	+ 1	0	0
63	"	b ₆	a ₁	b	- 1	0	-11	- 8	- 9	- 9	- 12
3	May 11, '06	b ₇	a ₁	b	+ 4	+ 4	+ 4	+ 3
3a	June 25, '07	b ₇	a ₂	b	+18	+ 4	+ 4
29	May 9, '06	b ₇	a ₁	b	+ 21	+ 15	+ 12	+ 10
30	"	b ₈	a ₁	b	+ 12	+ 5	+ 3	+ 1
46	June 23, '06	b ₈	a ₁	b	+24	+18	+ 17	+ 18	+ 16	+ 17
46a	June 25, '06	b ₈	a ₁	b	- 6	-16	- 16	- 16	- 15	- 18
46b	June 25, '07	b ₈	a ₂	b	+29	+10	+ 9
31	May 9, '06	b ₉	a ₁	b	+ 23	+ 16	+ 13	+ 10
47	June 23, '06	b ₉	a ₁	b	+ 2	+ 2	0	0
4	May 11, '06	b ₁₀	a ₁	b	- 7	- 6	- 4	- 6
4a	June 25, '07	b ₁₀	a ₂	b	+ 8	- 2	- 3
32	May 9, '06	b ₁₀	a ₁	b	- 18	- 20	- 23	- 22
33	"	b ₁₁	a ₁	b	+ 7	+ 5	+ 3	+ 2
48	June 23, '06	b ₁₁	a ₁	b	- 2	- 6	- 7	- 9	- 10	- 8
34	May 9, '06	b ₁₂	a ₁	b	- 14	+ 10	+ 7	+ 7
49	June 23, '06	b ₁₂	a ₁	b	0	- 3	- 6	- 7	- 6	- 8
6	May 11, '06	b ₁₃	a ₁	b	-12	-12	- 10	-11
6a	Dec. 3, '06	b ₁₃	a ₃	a	- 7	-10
6b	"	b ₁₃	a ₃	a	-10	- 9	Given to Prof. Hulett			
151	Dec. 15, '06	b ₁₄	a ₁	b	- 4	- 4	- 5
5	May 11, '06	b ₁₄	a ₁	b	0	- 1	0	- 1
14	May 16, '06	b ₁₅	a ₁	b	- 5	- 2	- 1	- 1
37	May 9, '06	b ₁₅	a ₁	b	- 7	- 6	- 8	- 6
15	May 16, '06	b ₁₆	a ₁	b	-14	-14	-13	-15
38	May 9, '06	b ₁₆	a ₁	b	- 5	Given to Prof. Hulett		
15a	June 25, '07	b ₁₆	a ₂	b	+30	+12	+11
178	Dec. 21, '06	b ₂₆	a ₃	a	+ 7	+ 8
179	"	b ₂₇	a ₃	a	+ 8	+10
180	"	b ₂₈	a ₃	a	- 8	- 9

TABLE IV.

Weston Cells.—Electrolytic Mercurous Sulphate made with New Apparatus.

Concentration of Sulphuric Acid exceeding Gram-Molecular.

[Differences in Microvolts from Mean of Reference Cells.]

Cell	Sept. 13	Oct. 13	Nov. 2	Nov. 19	Dec. 1	Jan. 10, 1907	Mar. 1	Mar. 25	Apr. 24	May 24	June 26	July 23
26	+ 10	+ 12	+ 15	+ 11	+ 13	+ 6	+ 10	+ 10	+ 7	+ 6	+ 5	+ 3
51	- 12	- 11	- 12	- 10	- 11	- 11	- 12	- 12	- 12	- 13	- 13	- 15
27	- 6	- 5	- 3	- 4	- 4	- 3	- 3	- 4	- 6	- 7	- 8	- 9
52	+ 4	+ 4	+ 4	+ 2	+ 1	+ 3	- 1	0	- 11	- 2	- 3	- 3
28	+ 18	+ 18	+ 21	+ 18	+ 18	+ 18	+ 17	+ 17	+ 14	+ 13	+ 9	+ 9
61	+ 2	- 2	- 1	- 1	+ 1	- 2	- 1	+ 1	0	- 1	0	- 3
62	- 4	- 4	- 5	- 6	- 4	- 2	- 7	- 6	- 6	- 7	- 8	- 9
63	- 11	- 9	- 9	- 8	- 8	- 8	- 9	- 10	- 10	- 12	- 11	- 13
3	+ 5	+ 5	+ 4	+ 4	+ 1	+ 5	+ 7	+ 6	+ 7	+ 6	+ 9	+ 8
3a											+ 18	- 3
29	+ 11	+ 12	+ 15	+ 12	+ 14	+ 9	+ 11	+ 13	+ 12	+ 13	+ 10	+ 9
30	+ 1	+ 1	+ 6	+ 3	+ 3	+ 4	+ 1	+ 4	+ 1	+ 1	+ 1	- 1
46	+ 14	+ 14	+ 11	+ 13	+ 12	+ 7	+ 8	+ 10	+ 7	+ 7	+ 6	+ 6
46a	- 19	- 17	- 20	- 17	- 16	- 16	- 18	- 20	- 17	- 20	- 21	- 17
46b											+ 29	- 5
31	+ 10	+ 9	+ 14	+ 10	+ 11	+ 11	+ 9	+ 11	+ 7	+ 6	+ 4	+ 1
47	- 2	- 1	- 2	- 1	- 1	- 3	- 5	- 6	- 8	- 8	- 10	- 14
4	- 6	- 6	- 7	- 7	- 6	- 7	- 5	- 9	- 7	- 7	- 6	- 6
4a											+ 8	- 10
32	- 21	- 26	- 11	- 24	- 24	- 24	- 30	- 33	- 30	- 35	- 34	- 34
33	+ 1	0	+ 5	+ 1	+ 5	+ 1	- 1	0	- 1	+ 1	0	- 3
48	- 11	- 10	- 11	- 11	- 9	- 11	- 12	- 10	- 13	- 12	- 14	- 15
34	+ 7	+ 7	+ 10	+ 6	+ 9	+ 5	+ 7	+ 10	+ 6	+ 7	+ 4	+ 3
49	- 9	- 9	- 10	- 8	- 8	- 10	- 11	- 10	- 13	- 11	- 13	- 14
6	- 11	- 10	- 12	- 10	- 9	- 11	- 9	- 9	- 9	- 9	- 10	- 8
6a						- 14	- 14	- 12	- 14	- 13	- 16	- 15
6b												
151						- 2	- 10	- 8	- 7	- 4	- 7
5	0	- 3	0	- 1	- 1	- 3	+ 3	+ 2	+ 2	+ 3	+ 2	+ 2
14	- 3	- 2	- 2	0	- 2	- 2	- 1	- 1	- 1	- 1	- 2	- 2
37	- 6	- 2	- 5	- 2	- 3	- 4	- 1	- 3	- 3	- 3	- 2
15	- 18	- 16	- 18	- 16	- 13	- 14	- 17	- 16	- 16	- 17	- 16	- 15
38												
15a											+ 30	- 5
178						+ 15	+ 13	+ 13	+ 14	+ 11
179						+ 21	+ 17	+ 18	+ 11	+ 5
180						- 7	- 12	- 10	- 8	- 11

TABLE IV—Continued.

Cell	Date	Mercurous sulphate	CdSO ₄	Cd Amalgam	*	**	***	July 5, 1906	July 20	Aug. 4	Aug. 21
190	June 25, '07	b ₂₉	a ₂	b	+24	+20	+ 6
191	"	b ₃₀	a ₂	b	- 1	0	- 8
192	"	b ₃₁	a ₂	b	+ 1	0	- 4
Exchange Samples											
12	May 16, '06	Hu-lett's I	a ₁	b	+26	+27	+29	+28
39	May 9, '06	"	a ₁	b	+ 42	+ 36	+ 38	+ 39
141	Dec. 3, '06	Hu-lett's II	a ₃	a	0	- 4	Given to Prof. Hulett			
141a	"	"	a ₃	a	+ 4	- 6
141b	"	"	a ₃	a	+13	0	Given to George Washington University			
142	Dec. 15, '06	"	a ₃	a	+12	- 3	+ 5
149	June 25, '07	Guthe	a ₂	b	+48	+42	+30

TABLE V.

Weston Cells.—Electrolytic Mercurous Sulphate made with New Apparatus.

Concentration of Sulphuric Acid, Gram-Molecular or Less.

[Differences in Microvolts from Mean of Reference Cells.]

Cell	Date	Mercurous sulphate	CdSO ₄	Cd Amalgam	*	**	***	July 5, 1906	July 20	Aug. 4	Aug. 21
50	June 23, '06	b ₂₀	a ₁	b	+19	+12	+ 9	+ 6	+ 2	- 4
53	"	b ₂₁	a ₁	b	+24	+25	+23	+29	+22	+19
54	"	b ₂₂	a ₁	b	+14	+11	+11	+13	+11	+ 7
55	"	b ₂₃	a ₁	b	- 3	- 5	- 4	- 1	- 3	- 4
56	"	b ₂₄	a ₁	b	+ 4	+ 3	+ 5	+ 9	+ 7	+ 5
57	"	b ₂₅	a ₁	b	+17	+15	+17	+17	+18	+16
58	"	b ₁₇	a ₁	b	+45	+27	+24	+19	+17	+14
69	June 25, '06	b ₁₇	a ₁	b	+ 7	+ 5	- 6	- 5	- 8	-17	- 9
59	"	b ₁₈	a ₁	b	+58	+54	+34	+34	+28	+19	+17
60	"	b ₁₉	a ₁	b	+20	+20	+ 6	+ 6	+ 6	- 3	- 2

TABLE IV—Continued.

Cell	Sept. 13	Oct. 13	Nov. 2	Nov. 19	Dec. 1	Jan. 10, 1907	Mar. 1	Mar. 25	Apr. 24	May 24	June 26	July 23
190											+ 24	- 5
191											- 1	- 17
192											+ 1	- 15
12	+ 26	+ 28	+ 29	+ 30	+ 28	+ 32	+ 30	+ 31	+ 31	+ 31	+ 31	+ 32
39	+ 37	+ 38	+ 38	+ 42	+ 35	+ 39	+ 39	+ 40	+ 37	+ 35	+ 36	+ 34
141												
141a						- 3	- 3	- 3	- 3	- 2	- 1	- 3
141b	Given to George Washington University											
142						+ 4	- 2	- 2	- 3	0	- 4
189											+ 48	+ 25

TABLE V.

Weston Cells.—Electrolytic Mercurous Sulphate made with New Apparatus.

Concentration of Sulphuric Acid, Gram-Molecular or Less.

[Differences in Microvolts from Mean of Reference Cells.]

Cell	Sept. 13	Oct. 13	Nov. 2	Nov. 19	Dec. 1	Jan. 10, 1907	Mar. 1	Mar. 25	Apr. 24	May 24	June 26	July 23
50	- 1	- 4	- 1	- 3	- 3	- 5	-10	- 8	-11	-10	-13	-15
53	+18	+17	+19	+18	+18	+ 6	+15	+18	+16	+16	+15	+15
54	+ 9	+10	+11	+ 9	+12	+ 3	+ 8	+11	+10	+10	+10	+ 8
55	- 1	+ 1	+ 2	0	+ 1	- 1	0	+ 2	+ 2	+ 2	+ 1	- 2
56	+ 5	+ 7	+ 8	+ 4	+ 6	+ 2	+ 8	+11	+ 9	+10	+10	+ 8
57	+15	+18	+17	+16	+15	+18	+20	+18	+19	+20	+18
58	+10	+13	+10	+ 7	+ 9	+ 9	+10	+12	+11	+12	+10	+ 9
69	- 9	- 8	-10	- 9	- 9	-11	-12	-11	-11	-11	-11	-14
59	+13	+14	+11	+ 8	+ 8	+ 4	- 4	- 6	-12	-16	-23	-22
60	- 6	- 6	- 8	-10	- 8	-12	-12	-12	-13	-14	-16	-15

TABLE VI.

Weston Cells—Chemically Prepared Mercurous Sulphate.

[Differences in Microvolts from Mean of Reference Cells.]

Cell	Date	Mer- curous sul- phate	CdSO ₄	Cd	*	**	***	July 5, 1906	July 20	Aug. 4	Aug. 21
86	June 26, '06	c	a ₁	b	+ 4	+ 4	- 5	+ 1	+ 3	+ 4	+ 5
99	June 27, '06	d ₁	a ₁	b	+ 51	+38	+20	+21	+13	+ 7	+ 5
99a	June 28, '06	d ₁	a ₁	b	+ 13	+ 2	- 9	- 7	-11	-16	-15
84	June 26, '06	d ₂	a ₁	b	- 11	-14	-16	-17	-18	-15	-18
84a	Dec. 3, '06	d ₂	a ₂	a	- 19	-17	-16
84b	"	d ₂	a ₂	a	- 15	-16	-16	Given to George Washington University			
1	May 11, '06	e ₁	a ₁	b	- 9	+ 7	- 1	- 1	- 5
43	May 9, '06	e ₁	a ₁	b	- 6	- 9	-11	-10
157	Dec. 15, '06	e ₁	a ₁	b	+ 23	- 3	- 5
*1a	June 25, '07	e ₁	a ₂	b	+ 47	+32	+27
103	June 27, '06	e ₂	a ₁	b	- 14	-16	-22	-21	-22	-23	-24
2	May 11, '06	e ₃	a ₁	b	- 4	- 3	- 2	- 5
44	May 9, '06	e ₃	a ₁	b	- 4	- 6	- 5	- 3
104	June 27, '06	e ₃	a ₁	b	- 17	-18	-20	-16	-14	-13	-13
2a	"	e ₃	a ₂	b	+ 32	+17	+11
105	"	e ₄	a ₁	b	+ 3	- 5	-13	-11	-11	-12	-15
106a	June 28, '06	e ₅	a ₁	b	- 9	-11	-15	-15	-17	-22	-18
107	"	e ₅	a ₁	b	- 11	-15	-16	-16	-18	-25	-22
98	June 27, '06	f ₁	a ₁	b	- 4	- 7	-10	-12	-10	-11	- 8
97	"	f ₂	a ₁	b	- 4	- 7	- 7	- 9	- 8	-10	- 9
100	June 27, '06	g ₁	a ₁	b	+ 26	+15	- 4	- 4	-17	-17	-17
100a	June 28, '06	g ₁	a ₁	b	+ 66	+43	+22	+22	+12	+ 3	+ 2
101	June 27, '06	g ₂	a ₁	b	+121
101a	June 28, '06	g ₂	a ₁	b	+112	+92	+78	+78	+59	+51	+48
163	Dec. 15, '06	g ₃	a ₂	a	+102	+81	+71
95	"	h ₁	a ₁	b	+ 1	-10	-23	-23	-26	-20	-27
96	"	h ₂	a ₁	b	+ 32	+19	+ 2	+ 2	+ 2	- 1	- 2
85	June 26, '06	h ₃	a ₁	b	+ 4	+ 1	- 6	- 7	- 7	-10	-12

TABLE VI.

Weston Cells—Chemically Prepared Mercurous Sulphate.

[Differences in Microvolts from Mean of Reference Cells.]

Cell	Sept. 13	Oct. 13	Nov. 2	Nov. 19	Dec. 1	Jan. 10, 1907	Mar. 1	Mar. 25	Apr. 24	May 24	June 26	July 23
86	+ 3	+ 4	+ 1	+ 1	0	- 2	- 3	- 4	- 7	- 5	- 7	- 9
99	0	- 2	- 3	- 4	- 5	- 4	-10	-11	-13	-13	-14	-16
99a	-18	-16	-16	-14	-15	-18	-18	-19	-20	-20	-18
84	-18	-19	-21	-19	-18	-19	-27	-30	-27	-33	-33	-30
84a	-16	-20	-18	-18	-21	-19	-19
84b	Given to George Washington University											
1	- 3	- 3	- 4	- 4	- 5	- 4	- 4	- 9	- 5	- 5	- 5	- 5
43	-11	-11	-11	- 8	- 5	-11	- 9	-11	- 7	-12	-15
157	-10	-19	-20	-15	-15	-19	-19
*1a	+47	+ 9
103	-24	-26	-25	-23	-20	-23	-23	-26	-23	-25	-29	-25
2	- 2	- 2	- 3	- 3	- 4	- 2	0	0	- 1	- 2	0	- 2
44	- 3	- 3	- 3	- 1	- 2	+ 1	- 3	- 3	- 3	- 3	- 7
104	-15	-12	-14	-11	- 9	- 8	-12	-10	-10	-10	-10	-12
2a	+32	- 2
105	-16	-16	-20	-17	-14	-15	-19	-18	-18	In Europe		
106a	-18	-18	-20	-16	-18	-19	-20	-19	-19	-23	-19
107	-21	-22	-23	-19	-27	-33	-39	-46	-51	-54	-52
98	- 8	- 7	- 9	- 8	- 6	- 5	- 9	- 6	- 7	- 9	-14
97	- 9	- 8	-10	-10	- 9	- 7	- 9	-10	-13	-10	-11	-14
100	-20	-22	-21	-19	-16	-20	-20	-20	-19	-14	-22	-19
100a	0	0	0	0	+ 3	- 3	- 1	- 1	+ 3	- 2	- 3
101
101a	+43	+43	+40	+40	+41	+42	+36	+36	+38	+39	+31	+25
163	+39	+14	+14	+10	+ 9	+ 4	+ 3
95	-28	-28	-28	-24	-24	-28	-29	-27	-28	-29	-28
96	- 5	- 4	- 4	- 7	- 5	- 4	-10	- 7	- 9	- 6	- 8	-12
85	-13	-12	-13	-14	-11	-15	-20	-23	-20	-27	-28	-27

TABLE VII.

Weston Cells—Specially Treated Commercial Samples of Mercurous Sulphate.

[Differences in Microvolts from Mean of Reference Cells.]

Cell	Date	Mer- curous sul- phate	CdSO ₄	Cd amalg.	*	**	***	July 5, 1906	July 20	Aug. 4	Aug. 21
93	June 27, '06	i ₁	a ₁	b	+ 44	+ 29	+ 14	+ 14	+ 12	+ 8	+ 9
94	" "	i ₂	a ₁	b	+ 24	+ 13	+ 5	+ 5	- 2	0	0
78	June 28, '06	k ₁	a ₁	b	- 22	- 24	- 19	- 19	- 18	- 22	- 18
79	June 26, '06	k ₂	a ₁	b	+ 10	+ 8	+ 5	+ 4	+ 5	+ 4	+ 6
80	" "	k ₃	a ₁	b	+ 15	+ 16	+ 18	+ 19	+ 23	+ 21	+ 22
81	" "	k ₄	a ₁	b	+ 6	+ 4	- 1	- 1	+ 2	0	0
82	" "	k ₅	a ₁	b	+ 13	+ 13	+ 9	+ 10	+ 14	+ 15	+ 14
83	" "	k ₆	a ₁	b	+ 17	+ 16	+ 2	+ 6
108	June 27, '06	l ₁	a ₁	b	+ 6	+ 4	+ 1	+ 4	+ 7	+ 8	+ 8
116	June 28, '06	l ₂	a ₁	b	+ 51	+ 51	+ 49	+ 54	+ 55	+ 50	+ 51
109	June 27, '06	l ₃	a ₁	b	+ 11	+ 4	- 3	0	+ 4	+ 5	+ 5
114	June 28, '06	l ₄	a ₁	b	+ 54	+ 64	+ 55	+ 61	+ 59	+ 52	+ 54
115	" "	l ₅	a ₁	b	+ 39	+ 40	+ 36	+ 41	+ 34	+ 34	+ 35
117	June 28, '06	m ₁	a ₁	b	+ 34	+ 25	+ 19	+ 28	+ 28	+ 24	+ 28
119	" "	m ₂	a ₁	b	+ 24	+ 15	+ 17	+ 17	+ 23	+ 19	+ 24
118	" "	m ₃	a ₁	b	+ 79	+ 75	+ 71	+ 79	+ 79	+ 75	+ 76
120	" "	m ₄	a ₁	b	+ 76	+ 75	+ 69	+ 78	+ 78	+ 74	+ 76
87	June 27, '06	n ₁	a ₁	b	+ 36	+ 33	+ 29	+ 33	+ 39	+ 40	+ 42
88	" "	n ₂	a ₁	b	+ 78	+ 74	+ 73	+ 72	+ 76	+ 80	+ 80
89	" "	n ₃	a ₁	b	+114	+108	+103	+107	+112	+113	+112
90	" "	n ₄	a ₁	b	+ 24	+ 19	+ 15	+ 18	+ 22	+ 20	+ 22
91	" "	n ₅	a ₁	b	+123	+123	+117	+118	+124	+123	+122
92	" "	n ₆	a ₁	b	+ 74	+ 73	+ 74	+ 73	+ 71	+ 68	+ 67

TABLE VII.

Weston Cells—Specially Treated Commercial Samples of Mercurous Sulphate.

[Differences in Microvolts from Mean of Reference Cells.]

Cell	Sept. 13	Oct. 13	Nov. 2	Nov. 19	Dec. 1	Jan. 10, 1907	Mar. 1	Mar. 25	Apr. 24	May 24	June 26	July 23
93	+ 5	+ 6	+ 4	+ 5	+ 4	+ 6	- 2	0	- 2	- 2	- 3	- 4
94	- 5	- 3	- 5	- 6	- 6	- 5	- 12	- 10	- 13	- 15	- 18	- 18
78	- 20	- 19	- 15	- 17	- 20	- 22	- 23	- 30	- 33	- 30
79	+ 3	+ 5	+ 5	+ 5	+ 3	+ 7	+ 3	+ 3	0	0	- 5	- 10
80	+ 21	+ 24	+ 25	+ 28	+ 27	+ 28	+ 26	+ 25	+ 24	+ 25	+ 24	+ 22
81	- 1	+ 1	0	+ 1	0	+ 2	- 1	- 1	- 1	- 2	- 4	- 7
82	+ 12	+ 14	+ 14	+ 15	+ 14	+ 16	+ 12	+ 13	+ 12	+ 12	+ 11	+ 8
83	0	+ 8	+ 5	+ 8	+ 8	+ 16	+ 15	+ 15	+ 16	+ 15	+ 10	+ 7
108	+ 5	+ 7	+ 5	+ 7	+ 4	+ 11	+ 3	+ 4	+ 4	+ 2	- 9	- 12
116	+ 51	+ 60	+ 54	+ 50	+ 52	+ 55	+ 50	+ 51	+ 51	+ 52	+ 50	+ 48
109	+ 3	+ 7	+ 5	+ 3	+ 5	+ 9	+ 3	+ 3	+ 3	+ 1	- 13	- 25
114	+ 54	†† 64	+ 59	+ 57	+ 59	+ 64	+ 59	+ 55	+ 61	+ 60	+ 59	+ 55
115	+ 32	†† 42	+ 35	+ 31	+ 32	+ 35	+ 30	+ 30	+ 31	+ 30	+ 23	+ 4
117	+ 28	†† 37	+ 31	+ 28	+ 26	+ 31	+ 23	+ 21	+ 21	+ 13	+ 11	+ 9
119	+ 22	†† 33	+ 26	+ 27	+ 24	+ 31	+ 26	+ 28	+ 26	+ 28	+ 27	+ 21
118	+ 78	†† 87	+ 84	+ 81	+ 83	+ 86	+ 83	+ 85	+ 86	+ 86	+ 86	+ 82
120	+ 74	†† 84	+ 79	+ 76	+ 78	+ 79	+ 75	+ 76	+ 76	+ 77	+ 74	+ 72
87	+ 39	+ 41	+ 40	+ 39	+ 41	+ 42	+ 36	+ 35	+ 35	+ 29	+ 22	+ 21
88	+ 75	+ 77	+ 77	+ 79	+ 78	+ 81	+ 76	+ 77	+ 78	+ 80	+ 77	+ 74
89	+108	+111	+109	+110	+110	+113	+106	+108	+107	+110	+107	+103
90	+ 20	+ 23	+ 21	+ 22	+ 24	+ 28	+ 23	+ 24	+ 25	+ 26	+ 22	+ 19
91	+118	+120	+119	+121	+120	+124	+120	+121	+122	+124	+121	+119
92	+ 65	+ 65	+ 65	+ 65	+ 64	+ 73	+ 69	+ 69	+ 70	+ 71	+ 69	+ 67

† Cells transferred to other bath.

TABLE VIII.

Clark Cells—Electrolytic Mercurous Sulphate made with old Apparatus.

[Differences in Microvolts from Mean of Reference Cells.]

Cell	Date	Mercurous sulphate	ZnSO ₄	Zn Amalg.	***	May 1, 1906	May 28	June 20	July 20	Aug. 4
57	Nov. 20, '06	a ₁	a	b	+46
58	"	a ₄	a	b	+34
59	"	a ₅	a	b	+38
60	"	a ₆	a	b	+34
42	Apr. 12, '06	a ₇	b	a	+1	-6	+12	+5	-17
42a	Nov. 23, '06	a ₇	a	b	+27
61	Nov. 20, '06	a' ₇	a	b	+20
43	Apr. 12, '06	a ₈	b	a	+41	+39	+46	+38	+37
62	Nov. 20, '06	a ₈	a	b	+15
63	"	a' ₈	a	b	+31
44	Apr. 12, '06	a ₉	b	a	-2	+1	-6	-18	-14
44a	Nov. 23, '06	a ₉	a	b	+44
64	Nov. 20, '06	a ₁₀	a	b	+11
65	"	a' ₁₀	a	b	+25
66	"	a ₁₁	a	b	+5
67	"	a' ₁₁	a	b	+4
68	"	a ₁₂	a	b	+10
69	"	a ₁₃	a	b	+2

Cells 57, 58, 60, 42, 62, 63, 67, 68, 69 found cracked and layer of zinc sulphate lifted. Replaced in bath after crystals were shaken back.

TABLE IX.

Clark Cells—Electrolytic Mercurous Sulphate made with New Apparatus.

Concentration of Sulphuric Acid exceeding Gram-Molecular.

[Differences in Microvolts from Mean of Reference Cells.]

Cell	Date	Mercurous sulphate	ZnSO ₄	Zn amalg.	*	**	***	May 1, 1906	May 28	June 20	July 20
27a	Apr. 12, '06	b ₁	b	a	+5	-1	+5	+5
27b	"	b ₁	b	a	0	-1	-2	0
27c	Nov. 23, '06	b ₁	a	b	+20	+8
28	Apr. 12, '06	b ₂	b	a	+4	+2	-3	-2
28a	Nov. 23, '06	b ₂	a	b	+13	+1
28b	June 28, '07	b ₂	a	b	+22	+21	+9
29	Apr. 12, '06	b ₃	b	a	-1
29a	Nov. 23, '06	b ₃	a	b	+13	+7

TABLE VIII.

Clark Cells—Electrolytic Mercurous Sulphate made with old Apparatus.

[Differences in Microvolts from Mean of Reference Cells.]

Cell	Sept. 13	Oct. 13	Nov. 2	Nov. 19	Dec. 1	Jan. 10, 1907	Mar. 1	Mar. 26	May 24	July 23.
57					+41	+20	+ 2	+ 8	-21	+ 6
58					+31	+14	-21	+12	broken	
59					+33	+28	+32	+33	+30	+30
60					+29	+15	+19	+20	+20	+20
42						+10	-10	- 3	-10	-13
42a					+21	+14	+21	+20	+19	+17
61					+18	+13	+19	+19	+20	+18
43	+37	+35	+35	+34	+28	+30	+34	+32	+31	+26
62					+14	- 7	cracked			
63					+28	+ 5	+19	+12	+ 5	+21
44	-10	- 8	-11	- 5			broken			
44a					+42	+29	+33	+33	+32	+29
64					+10	+ 2	+ 6	+ 7	+ 6	+ 6
65					+24	+15	+17	+18	+18	+ 4
66					+ 3	+ 1	+ 5	+ 5	+ 7	+ 7
67					+ 1	- 5	+ 6	+ 7	+ 7	+12
68					+ 5	- 7	- 3	- 1	broken	
69					0	-22	-18	-20	broken	

Cells 57, 58, 60, 42, 62, 63, 67, 68, 69 found cracked and layer of zinc sulphate lifted. Replaced in bath after crystals were shaken back.

TABLE IX.

Clark Cells—Electrolytic Mercurous Sulphate made with New Apparatus.

Concentration of Sulphuric Acid exceeding Gram-Molecular.

[Differences in Microvolts from Mean of Reference Cells.]

Cell	Aug. 4	Sept. 13	Oct. 13	Nov. 2	Nov. 19	Dec. 1	Jan. 10, 1907	Mar. 1	Mar. 26	May 24	July 24
27a	+ 4	+ 4	+ 4	+ 4	+ 5	+ 5	+ 4	+ 4	+ 5	+ 7	+ 4
27b	Broken										
27c						+ 6	+ 6	+ 6	+ 6	+ 7	+90 ¹
28	- 4	- 5	- 6	- 5	- 4	- 4	- 6	- 7	- 7	- 4	- 5
28a						- 1	+ 1	+ 1	+ 1		
28b											+10
29											
29a						+ 5	+ 2	+ 3	+ 3	- 8	+ 2

¹ High resistance. Seal defective?

TABLE IX—Continued.

Cell	Date	Mercurous sulphate	ZnSO ₄	Zn amalg.	*	**	***	May 1, 1906	May 28	June 20	July 20
73	Nov. 23, '06	b ₄	a	b	+19	+ 7
74	"	b ₅	a	b	+28	+17
75	"	b ₆	a	b	+24	+ 8
30	Apr. 12, '06	b ₇	b	a	+15	+19	+16	+15
30a	Nov. 23, '06	b ₇	a	b	+16	+ 9
30b	"	b ₇	a	b	+18	+19
31	Apr. 12, '06	b ₈	b	a	- 6	+ 3	- 2	Broken
31a	Nov. 27, '06	b ₈	a	b	+ 9	+ 6	+ 6
31b	Nov. 23, '06	b ₈	a	b	+ 9	- 3
31c	Nov. 27, '06	b ₈	a	b	0	0	+ 2
31d	"	b ₈	a	b	+14	+12	+ 4
32	Apr. 12, '06	b ₉	b	a	+ 2	+ 6	+ 8	+ 5
32a	Nov. 23, '06	b ₉	a	b	+27	+17
32b	June 28, '07	b ₉	a	b	+14	+13	+ 8
33	Apr. 12, '06	b ₁₀	b	a	- 5	- 5	Broken
33a	Nov. 23, '06	b ₁₀	a	b	+ 6
34	Apr. 12, '06	b ₁₁	b	a	+ 2	+ 1	+ 2	- 1
34a	Nov. 23, '06	b ₁₁	a	b	+ 7	+ 7	+ 4
34b	June 25, '07	b ₁₁	a	b	+22	+20	+14
35	Apr. 12, '06	b ₁₂	b	a	+ 4	+ 5	+ 6	+ 5
36a	Nov. 23, '06	b ₁₃	a	b	+ 8	+ 6
36b	Dec. 3, '06	b ₁₃	a	b	+ 8
36c	"	b ₁₃	a	b	+ 8
37	Apr. 12, '06	b ₁₄	b	a	+10	+10	0	+ 3
38	"	b ₁₅	b	a	+ 9	+10	+ 4	+10
39	"	b ₁₆	b	a	-13	-10	-10	- 5
39a	Nov. 23, '06	b ₁₆	a	b	+ 7	+ 4
39b	June 25, '07	b ₁₆	a	b	+ 6	+ 9	+ 7
40	Apr. 11, '06	Hu- lett's I	b	a	+35	+39
41	"	Hu- lett's I	b	a	+24	+30	+30	+32
70	Nov. 20, '06	Hu- lett's I	a	b	+53
71	"	Hu- lett's II	a	b	+17
71a	Dec. 3, '06	Hu- lett's II	a	b	+16
71b	"	Hu- lett's II	a	b	+17
111	June 28, '07	Guthe	a	b	+51	+49

TABLE X.

Clark Cells—Electrolytic Mercurous Sulphate made with New Apparatus.

Concentration of Sulphuric Acid, Gram-Molecular or Less.

[Differences in Microvolts from Mean of Reference Cells.]

Cell	Date	Mercurous sulphate	ZnSO ₄	Zn amalg.	Nov. 26, 1906	Nov. 27	Nov. 28
48	Nov., '06	b ₂₀	a	b	+22	+17	+17
49	"	b ₂₁	a	b	+23	+15	+15
50	"	b ₂₂	a	b	+25	+21	+18
51	"	b ₂₃	a	b	+19	+15	+11
52	"	b ₂₄	a	b	+23	+22	+17
53	"	b ₂₅	a	b	+36	+34	+32
54	"	b ₁₇	a	b	+13	+17	+ 3
55	"	b ₁₈	a	b	+17	+13	+ 8
56	"	b ₁₉	a	b	+26	+23	+20

TABLE XI.

Clark Cells—Chemically Prepared Mercurous Sulphate.

[Differences in Microvolts from Mean of Reference Cells.]

Cell	Date	Mercurous sulphate	ZnSO ₄	Zn amalg.	*	**	***	May 1, 1906	May 28	June 20	July 20
78	Nov. 23, '06	c	a	b	+ 7
79	"	d ₁	a	b	+ 9
76	"	d ₂	a	b	+ 5
46	Apr. 12, '06	e ₁	b	a	-12	-14	-20	-17
46a	Dec. 3, '06	e ₁	a	b	+ 1
46b	"	e ₁	a	b	- 3
86	Nov. 27, '06	e ₁	a	b	+ 1	- 2	- 1
86a	June 28, '07	e ₁	a	b	+ 7	+ 5
87	"	e ₂	a	b	0	- 2	- 2
88	"	e ₃	a	b	- 3	- 2	+ 1
89	"	e ₄	a	b	+12	+10	+ 6
90	"	e ₅	a	b	+ 6	+ 2	+ 1
91	"	e ₆	a	b	- 2	- 4	+ 1
91a	"	e ₆	a	b	- 1	- 4	- 4
45	Apr. 12, '06	f ₁	b	a	+ 4	+ 3	+ 7	+ 7
47	"	f ₂	b	a	- 5	- 3	- 7	0
84	Nov. 27, '06	g ₁	a	b	+36	+19	+11
85	"	g ₃	a	b	+26	+19	+11
82	Nov. 27, '06	h ₁	a	b	0	-11	-12
83	"	h ₂	a	b	+21	+ 8	+ 4
77	Nov. 23, '06	h ₃	a	b	+ 8

TABLE X.

Clark Cells—Electrolytic Mercurous Sulphate made with New Apparatus.

Concentration of Sulphuric Acid, Gram-Molecular or Less.

[Differences in Microvolts from Mean of Reference Cells.]

Cell	Dec. 1	Dec. 6	Jan. 4, 1907	Jan. 10	Jan. 31	Mar. 1	Mar. 26	May 24	July 23
48	+15	+15	+11	+14	+15	+15	+14	+15	+11
49	+13	+13	+ 4	+ 5	- 2	+ 5	+ 7	+ 8
50	+15	+16	+ 7	+15	Cracked		- 5
51	+14	+14	+10	+22 Lifted	
52	+20	+21	+20	+23	+24	+23	+24	+25	+23
53	+34	+30	+28	+31	+33	+35	+37
54	+ 4	+ 5	+ 2	+ 5	Lifted	
55	+ 8	+ 8	+ 6	+ 8	+ 9	+12	+ 8	+10	+ 9
56	+17	Broken	

TABLE XI.

Clark Cells—Chemically Prepared Mercurous Sulphate.

[Differences in Microvolts from Mean of Reference Cells.]

Cell	Aug. 4	Sept. 13	Oct. 13	Nov. 2	Nov. 19	Dec. 1	Jan. 10, 1907	Mar. 1	Mar. 26	May 24	July 23
78	+ 8	+ 7	+16	+18	+17	+13
79	+11	+ 5	Cracked		+ 9
76	+ 6	- 4	+ 1	- 2	+ 6	+29
46	-14	-11	-12	-13	- 8	- 7	- 8	- 4	- 4	- 4	- 4
46a	- 8	- 4	- 3	- 4	- 4
46b	- 8	- 2	- 4	- 4
86	-17	-17	-13	-12	- 8
86a	+ 3
87	- 7	- 3	- 3	- 2	- 1
88	- 2	+ 3	+ 4	+ 7	+ 4
89	- 2	0	+ 1	+ 2	+ 1
90	- 7	- 1	- 2	- 3	- 3
91	- 8	- 2	- 2	- 2	- 3
91a	- 8	- 3	- 2	- 2	+ 1
45	+ 8	+11	+ 9	+ 8	+11	+ 8	+ 9	+13	+14	+15	+13
47	+ 1	+ 1	- 1	+ 1	+ 1	- 1	- 1	+ 4	+ 4	+ 3	- 1
84	+17	+ 5	Cracked	
85	+17	-13	- 3	- 2	+ 5
82	-13	-17	-13	-13	-13	-11
83	+ 6	- 3	+ 3	+ 2	+ 2	+ 2
77	+10	+ 9	+11	+11	+12	+11

TABLE XII.

Clark Cells.—Specially Treated Commercial Samples of Mercurous Sulphate.

[Differences in Microvolts from Mean of Reference Cells.]

Cell	Date	Mercurous sulphate	ZnSO ₄	Zn Amalg.	*	**	***	May 1, 1906	May 28	June 20	July 20
80	Nov. 27, '06	i ₁	a	b	+10	+ 3	+ 1
81	"	i ₂	a	b	+ 3	- 2	- 3
21	April 11, '06	k ₁	b	a	+ 2	+ 2	- 6	- 3
22	"	k ₂	b	a	+ 23	+ 25	+ 15	+ 17
23	"	k ₃	b	a	+ 55	+ 50	+ 56	+ 51
23a	Nov. 23, '06	k ₃	a	b	+29
24	April 11, '06	k ₄	b	a	+ 25	+ 27	+ 19	+ 20
24a	Nov. 27, '06	k ₄	a	b	+11	+ 9	+ 9
25	April 11, '06	k ₅	b	a	+ 50	+ 47	+ 47	+ 48
25a	Nov. 23, '06	k ₅	a	b	+26
26	April 11, '06	k ₆	b	a	+ 16	+ 17	+ 29	+ 20
92	Nov. 27, '06	l ₁	a	b	+28	+26	+29
93	"	l ₂	a	b	+57	+57	+61
94	"	l ₃	a	b	+25	+25	+20
95	"	l ₄	a	b	+71	+77	+77
96	"	l ₅	a	b	+47	+52	+52
15	April 11, '06	n ₁	b	a	+ 59	+ 65	+ 55	+ 61
16	"	n ₂	b	a	+112	+121	+111	+115
16a	Nov. 27, '06	n ₂	a	b	+76	+77	+78
17	April 11, '06	n ₃	b	a	+143	+147	Broken	
17a	Nov. 23, '06	n ₃	a	b	+76
18	April 11, '06	n ₄	b	a	+ 74	+ 71	+ 59	+ 62
19	"	n ₅	b	a	+162	+157	+145	+146
20	"	n ₆	b	a	+ 96	+ 97	+ 93	+ 93

TABLE XII.

Clark Cells—Specially Treated Commercial Samples of Mercurous Sulphate.

[Differences in Microvolts from Mean of Reference Cells.]

Cell	Aug. 4	Sept. 13	Oct. 13	Nov. 2	Nov. 19	Dec. 1	Jan. 10, 1907	Mar. 1	Mar. 26	May 24	July 23
80	+ 1	- 7	- 3	- 2	- 1	- 6
81	- 4	- 8	- 3	- 3	- 1	- 3
21	0	0	- 2	- 4	- 4	- 4	+ 2	+ 2	+ 1	- 1	- 5
22	+ 17	+ 21	+ 24	+ 25	+ 23	+ 25	+ 28	+ 33	+35	+ 28	+12
23	+ 48	+ 49	+ 53	+ 48	+ 49	+ 46	+ 49	+ 52	+53	+ 55	+52
23a	+ 30	+ 31	+ 35	+ 36	+37
24	+ 17	+ 19	+ 18	+ 17	+ 14	Broken	
24a	+ 7	+ 6	+ 2	- 2	0	+14
25	+ 46	+ 49	+ 50	+ 48	+ 53	+ 52	+ 56	+ 58	+59	+ 58	+45
25a	+ 25	+ 26	+ 30	+33	+ 32	+29
26	+ 20	+ 17	+ 20	+ 18	+ 19	+ 16	+ 20	+ 24	+24	+ 22	+16
92	+ 24	+ 20	+ 24	+28	+ 22	+ 9
93	+ 55	+ 57	+ 63	+60	+ 60	+59
94	+ 23	- 1	Broken	
95	+ 75	+ 67	+ 73	+71	+ 72	+73
96	+ 50	+ 42	+ 41	+43	Broken	
15	+ 60	+ 60	+ 57	+ 56	+ 60	+ 51	+ 42	+ 35	+39	+ 33	+29
16	+121	+114	+114	+118	+118	Broken	
16a	+ 75	+ 75	+ 81	+81	+ 79	+79
17
17a	+ 74	+ 67	Cracked	
18	+ 66	+ 65	+ 64	+ 63	+ 67	+ 67	+ 68	+ 73	+72	+ 68	+65
19	+149	+146	+146	+152	+150	+150	+141	+142	+89	Cracked	+85
20	+ 94	+ 93	+ 93	+ 94	+ 95	+ 92	+ 93	+ 99	+98	+100	+99

TABLE XIII.

Clark Cells.—Set up with Commercial Samples of Mercurous Sulphate according to Old Specifications.

[Differences in Microvolts from Mean of Reference Cells.]

Cell	Date	Mercurous Sulphate	ZnSO ₄	Zn Amalg.	May 1, 1906	May 28	June 20	July 20	Aug. 4
1	April 9, '06	Kahlbaum A	b	a	+ 387	+ 353	+ 327	+ 320	+ 319
2	"	"	b	a	+ 442	+ 379	+ 378	+ 366	+ 366
3	"	"	b	a	+ 442	+ 375	+ 372	+ 362	+ 360
10	"	Kahlbaum B	b	a	+ 526	+ 489	+ 487	+ 489	+ 482
14	April 11, '06	Kahlbaum C	b	a	+ 305	+ 245	+ 241	+ 221	+ 212
6	April 9, '06	"	b	a	+ 404	+ 302	+ 295	+ 272	+ 265
5	"	Merck	b	a	+ 282	+ 248	+ 248	+ 244	+ 249
12	"	Schuchardt	b	a	+2202	+1652	+1587	+1366	+1275
13	"	"	b	a	+2172	+1646	+1585	+1350	+1241
8	"	Gehe	b	a	+ 412	+ 377	+ 376	+ 373	+ 376
9	"	"	b	a	+ 422	+ 381	+ 383	+ 377	+ 379

TABLE XIV.

Exchange Cells.

[Differences in Microvolts from Mean of Reference Cells.]

WESTON CELLS.

Cell	Date	Mercurous Sulphate	CdSO ₄	Cd Amalg.	July 5, 1906	July 20
F7	Hulett Feb. 15, '04	1:6H ₂ SO ₄ D=.25	Kahl. recrystallized	12½ % C.P. Merck	- 62
O4	Hulett
O5	Hulett
A3	Hulett Oct. 21, '05	1:6H ₂ SO ₄ D=.82	Kahl. recrystallized	12½ % C.P. Merck	+ 48
A52	Hulett July, '06	1:6H ₂ SO ₄ D=.35	Kahl. recrystallized	12½ % C.P. Merck	+ 34
1	Nat. Phy. Lab. Feb., '06	Fuming Sulphuric.....	9 % Cd.....	-80
2	Nat. Phy. Lab. Feb., '06	Fuming Sulphuric.....	9 % Cd.....	-85
C1	Guthe.....	Merck and Baker, recrystallized	12½ % Kahl.....
5	Carhart July 21, '06	El. 1:9H ₂ SO ₄
8	Carhart July 25, '06	El. 1:9H ₂ SO ₄
1	W. W. Strong. June 15, '07	b29	12.1 % Kahl. El.
2	W. W. Strong. June 15, '07	b29	"
3	W. W. Strong. June 15, '07	b29	"

TABLE XIII.

Clark Cells.—Set up with Commercial Samples of Mercurous Sulphate according to Old Specifications.

[Differences in Microvolts from Mean of Reference Cells.]

Cell	Sept. 13	Oct. 13	Nov. 2	Nov. 19	Dec. 1	Jan. 10, 1907	Mar. 1	Mar. 26	May 24	July 23
1	+ 307	+307	+303	+300	+297	+297	+294	+290	+287	+267
2	+ 359	+357	+352	+355	+351	+256	+334	+328	+344	+311
3	+ 351	+352	+347	+349	+348	+348	+350	+344	+326	+328
10	+ 473	+474	+470	+472	+470	+473	+474	+468	+473	+461
14	+ 190	+181	+178	+177	+172	+172	+172	+163	+158	+142
6	+ 246	+237	+240	+226	+219	+214	+203	+194	+187	+170
5	+ 241	+242	+230	+240	+239	+240	+239	+233	+230	+217
12	+1066	+937	+854	+790	+745	+598	+414	+322	+180	Cracked
13	+ 977	+790	+669	Cracked		+ 27
8	+ 369	+371	+370	+369	+367	+371	+373	+368	+372	+364
9	+ 373	+378	+377	+379	Broken	

TABLE XIV.

Exchange Cells.

[Differences in Microvolts from Mean of Reference Cells.]

WESTON CELLS.

Cell	Aug. 4	Aug. 21	Sept. 13	Oct. 13	Nov. 2	Nov. 19	Dec. 1	Jan. 10, 1907	Mar. 1	Mar. 25	Apr. 24	May 24	June 26	July 23
F7	-67	-80	- 88	- 96	-118	-121	-126	-150	-227	-306	-375	-417	-466	-500
O4	+47	+47	+ 47	+ 47	+ 49	+ 50	+ 45	+ 50	+ 46	+ 47	+ 46	+ 49	+ 51	+ 51
O5	+17	+25	+ 26	+ 35	- 23	- 21	+ 8	- 43	- 25	0	+ 6	- 17	-119	-956
A3	+46	+48	+ 47	+ 49	+ 49	+ 50	+ 47	+ 52	+ 48	+ 48	+ 47	+ 44	+ 41	+ 42
A52	+30	+30	+ 27	+ 28	+ 30	+ 32	+ 32	+ 29	+ 29	+ 30	+ 29	+ 29	+ 28	+ 29
1	-78	-91	- 95	-107	-113	-130	-165	-173	-186	-208	-226	-242
2	-98	-99	-107	-111	-126	-112	-128	-112	-129	- 96	-125	-122	-107
C1	+ 26	+ 25	+ 23	+ 22	+ 17	+ 18	+ 16
5	+ 4	0	0	- 1	0	- 3	- 3
8	+ 12	+ 11	+ 13	+ 9	+ 10	+ 9	+ 7
									June 22	June 24	June 26	June 29	July 10	July 23
1	+38	+29	+27	+20	+ 8	+ 1
2	+53	+41	+36	+30	+14	+ 6
3	+10	-15	-16	-16	-17	-23

TABLE XIV—Continued.

CLARK CELLS.

Cell		Date	Mercurous Sulphate	ZnSO ₄	Zn Amalg.	July 20, 1906	Aug. 4
H4	Hulett	Mar. 15, '04	1:6 H ₂ SO ₄ D=.25...	Sch. twice re-crystalized	10 % C. P. — Baker	0	-9
H18	Hulett	Feb. 25, '06	1:6 H ₂ SO ₄ D=.82...	El. A twice re-crystalized	10 % C. P. — Baker	-2	+6
b1	Guthe.....	Hulett	C.P. Sch. re-crystalized	10 %.....
c2	Carhart	Nov. 14, '06	El. 1:6 H ₂ SO ₄

TABLE XV.

Weston Cells.

(Set up by Mr. P. I. Wold.)

[Differences in Microvolts from Mean of Reference Cells.]

1906

Cell	Date	Hg ₂ SO ₄	CdSO ₄	Cd Amalg.	Hg.	June 30, a. m.	June 30, p. m.	July 3
20	June 8, '06	1:6 H ₂ SO ₄	Recrystalized	12½ % by Electrolysis	Vac. distilled	-19	-11	-23
27	"	D=.3 Amp.	"	"		+10	+16	-10
21	"	"	"	"		-5	-2	-18
24	"	"	"	"		0	+6	-11

1907

Cell	Date	Hg ₂ SO ₄	CdSO ₄	Cd Amalg.	Hg.	June 14	June 14	June 15
42	April, '07	1:6H ₂ SO ₄ D=3	Recrystalized	By Electr.	Vac. distilled	-7	-9	-9
46	"	" D=1	"	" "		+2	0	+1
49	"	" D=1	"	Melted		-25	-21	-22
50	"	" D=1	"	"		+14	+13	+13
55	"	Hulett's	"	By Electr.		-17	-17	-15
57	"	1:6H ₂ SO ₄ D=.4	"	" "		-52	-53	-58

TABLE XIV—Continued.

CLARK CELLS.

Cell	Sept. 13	Oct. 13	Nov. 2	Nov. 19	Dec. 1	Jan. 10, 1907	Mar. 1	Mar. 26	May 24	July 23
H4	- 8	- 5	- 7	+ 1	0	- 3	- 1
H18	+14	+16	+13	+18	+15	+22	+25	+30	+22	+21
b1	+71	+58	+65	+63
c2	+14	+44	- 8	-18

TABLE XV.

Weston Cells.

(Set up by Mr. P. I. Wold.)

[Differences in Microvolts from Mean of Reference Cells.]

1906

Cell	July 5, a. m.	July 5, p. m.	July 6	July 9	July 11	July 20	July 24	Aug. 4	Aug. 17	Sept. 11	Sept. 13
20	-16	-11	-12	-13	-12	-17	-11	-23	-12	- 6	-15
27	- 4	+ 4	- 1	- 3	- 2	-13	- 8	-14	-17	- 9	-11
21	-17
24	- 9

1907

Cell	June 17	June 18	June 19	June 20	June 21	June 22	June 24	June 26	June 29	July 10	July 23
42	- 7	-10	- 9	- 9	- 9	-12	- 9	- 9	-11
46	+ 5	+ 1	0	+ 2	+ 3	+ 1	+ 4	+ 2	+ 1
49	-18	-20	-19	-19	-20	-22	-19	-19	-14
50	+13	+16	+15	+16	+16	+15	+18	+17	+18
55	-15	-16	-16	-16	-16	-16	-14	-15	-12
57	-58	-61	-60	-61	-64	-65	-62	-59	-53	-68	-69

DISCUSSION OF RESULTS.

Weston cells.—An inspection of the figures given in Tables III to VII shows that there is a highly satisfactory agreement between cells made with all the samples of mercurous sulphate prepared by methods *a* to *k*, inclusive, with the exception of a few of the white samples prepared in 1904, of which only scant quantities were preserved. In addition, two of these, a_5 and a_6 , were somewhat discolored, probably by the action of light.

In cells Nos. 26 to 44, inclusive, the first Weston cells set up in 1906, the platinum terminals inside the cell were not amalgamated. Perhaps for this reason the agreement was not as close as could have been wished, as duplicates with amalgamated terminals showed a much smaller deviation from the mean. In general the cells with abnormally high initial values, with the exception of those in Table VII, have shown a decided decrease, in a few cases dropping below the normal value. Cells 9 and 42 showed a sudden decrease in value, but in each case they were found to have cracked.

The most satisfactory results, on the whole, were obtained with cells in which gray samples of electrolytic sulphate were employed, as shown in Table IV. A comparison of the values on July 20, 1906, and July 23, 1907, shows an average decrease of 6 microvolts for the interval. (Table XVII.)

Even with the samples of electrolytic mercurous sulphate prepared with more dilute sulphuric acid ($V=1, 2,$ and 5), Table V, the agreement is very good and with the exception of No. 59, which had the highest initial value, the average relative change within the above-mentioned interval being 13 microvolts.

The agreement of the cells in Table VI, in which chemically prepared sulphate was used, compared with those made with electrolytic sulphate, is excellent; relatively large changes are shown, however, by the three samples made by reduction of mercuric sulphate by sulphurous acid, which gave abnormally high initial values, and by cell 107.

From Table VII it may be seen that commercial samples of mercurous sulphate, when digested with sulphuric acid, no longer show the large initial changes ordinarily observed when this treatment is omitted, and that digestion with hot 1:4 sulphuric acid, series *i* and *k*,

brings the commercial samples into excellent agreement with those prepared electrolytically. With few exceptions, the relative changes are very small. Most of the samples of series *l*, *m*, and *n*, which were prepared by allowing commercial mercurous sulphate to stand for a long time in contact with sulphuric acid, gave slightly high initial values which have persisted, in marked contrast with the usual behavior in such cases.

Clark cells.—The agreement of the Clark cells is on the whole somewhat better than that of the Weston cells, though, on account of their tendency to crack and the fact that many of them were not set up until November, 1906, the tables are less complete than in the case of the Weston cells. Although some of the Clark cells are more than a year old, the formation of gas at the amalgam limb, so frequently mentioned, has not been observed in cells which cracked in the bath, and which, therefore, were completely immersed in the kerosene. In such cases the development of a crack was generally followed by infinite resistance owing to the penetration of kerosene into the cell, in consequence of the slightly diminished pressure produced in sealing. As shown in the tables the cells resumed their normal values on cautiously shaking down the crystals which had been lifted by the layer of kerosene. In cases where the crack was so large as to expose the amalgam the electromotive force rapidly decreased.

Tables VIII to XII give the results obtained in the same order as in Tables III to VII. The deviations from the mean for the same sample of mercurous sulphate will, in general, be found to agree closely for both types of cell.

Table XIII gives the measurements on Clark cells set up with six untreated commercial samples of mercurous sulphate in accordance with the old specifications, in which the zinc sulphate solution was treated with an excess of zinc oxide, then with mercurous sulphate and filtered, while the latter was washed with water. These cells were set up in April, 1906, and had very high initial values in May, when first measured, and after the lapse of a year are, on the average, 280 microvolts above the mean.

Exchange cells.—During the progress of the work Clark and Weston cells were exchanged with Professors Hulett, Carhart, and Guthe, and in June, 1906, two Weston cells were kindly sent us by

the National Physical Laboratory of England. These have been kept under continuous observation, and the results obtained are given in Table XIV. This table also gives the measurements on three Weston cells set up by Mr. W. W. Strong at the Johns Hopkins University with mercurous sulphate, mercury, and cadmium furnished by the Bureau, the cadmium sulphate being purified by him.⁴³

In July, 1906, a number of Weston cells set up by Mr. P. I. Wold, of Cornell University, were measured at the Bureau; the results obtained on these and also on others received in June, 1907, are given in Table XV. Further data on these and the exchange cells, kindly placed at our disposal by Professors Carhart, Hulett, and Guthe, and by Mr. Wold, are given in the tables.

Professor Hulett's cells, with the exception of F_7 and O_5 , have not appreciably changed with respect to our cells during the period in which they have been under observation. Both of these cells, as well as O_4 , have defective seals which have allowed the penetration of oil. The paste of F_7 is quite brownish and the amalgams of F_7 and O_5 are slightly coated with a black deposit, possibly finely divided mercury. In addition, the values of O_5 show irregular changes.

The agreement of the cells of Guthe and von Ende⁴⁴ with the Bureau's cells indicates that the Clark cells obtained by them from Professor Hulett, constructed in 1904 and used as their basis of reference, must have suffered some change, possibly due to "exposure for some weeks to diffused light." Although Guthe and von Ende found relatively large initial changes in the electromotive force of their Weston cells, the measurements made at the Bureau on one of them showed that it had reached a practically constant value in close agreement with the Bureau cells when received.

The results obtained with the exchange cells, with the exception of cells F_7 and O_5 and the two cells from the National Physical Laboratory of England, which also contain oil, show that cells set up by different observers are in satisfactorily close agreement. This is also shown by the cells set up at the Bureau with samples of

⁴³Three abnormally low Clark cells, two probably inverted, were also received from Mr. Strong.

⁴⁴Phys. Rev., **24**, p. 214 (1907).

mercurous sulphate obtained from Professors Hulett and Guthe. (Tables IV and IX.)

TABLE XVI.

Values of Weston Cells in Terms of Clark Cells.¹

Date	Diff. method	Direct method	Date	Diff. method	Direct method
June 1, '06	1.018859	Sept. 13, '06	1.018892	1.018890
June 2	65	Sept. 21	72	81
June 4	58	1.018854	Oct. 13	77	70
June 7	65	66	Nov. 3	70	74
June 9	51	59	Nov. 6	74	77
June 11	66	67	Nov. 17	68	76
June 13	62	65	Nov. 19, A. M.	66
June 18	63	Nov. 19, P. M.	69
June 19	61	64	Nov. 24	79
June 20	63	64	Dec. 8	79	83
June 22	61	63	Mar. 2, '07	70	73
July 14	78	82	Mar. 27	64
July 20	88	May 29	69	68
July 24	73	80	July 26	68	72
July 26	76	81	July 29	59
Aug. 21	84	99	July 30	69
			Mean	1.018869	1.018873

¹ Weston cells 1, 2, 3, 4, 5, 6, 8, 9, 11, 12, 14, and 15. Clark cells 27a, 28, 32, 34, and 39.

Relative values of Weston and Clark cells.—Table XVI shows the values of the mean of the twelve Weston cells, taken as the basis of reference, in terms of five Clark cells similarly used. The measurements were made by the direct and differential methods. In the former, the five Clark cells and seven of the twelve Weston cells were separately measured, and in the latter the cells of each set were arranged in series and the difference obtained by placing the sets in opposition. In the computations the value of the mean of the Clark cells was taken as 1.42110 volts at 25°, derived from the value, 1.434 volts at 15°,⁴⁵ adopted by the Chicago Congress for the Clark cell set up in accordance with the old specifications. A correction of -0.00030 volt was made for the average difference in electromotive force obtained with the specially prepared mercurous sulphate.

On account of breakage the same five Clark cells were not employed throughout the whole period, but the results were reduced

⁴⁵ $E_t = E_{15} - .00119 (t - 15) - .000007 (t - 15)^2$.

to the mean of the five which lasted longest. The new cells substituted for the broken ones agreed closely with the latter, so that the necessary corrections in no case exceeded five microvolts.

The close agreement between the results obtained by the direct and differential methods indicates that errors incident to electrical measurements are practically eliminated. The values obtained on the dates given can therefore be affected only by errors in temperature measurement ($0.01^\circ = 9$ microvolts), by possible hysteresis due to occasional interruptions in the regulation of the baths, and to possible ageing. The variations observed are, with two or three exceptions, so slight that they can be accounted for by an error of $\pm 0.01^\circ$ in reading the temperature. It may, therefore, be safely concluded that the Weston cells in terms of which the results are expressed have not changed with reference to the Clark cells, during the fourteen months, by as much as 20 microvolts. This conclusion is also confirmed, as shown in the tables, by the close agreement of cells set up at different times with the same sample of mercurous sulphate.

SUMMARY OF RESULTS.

For ready comparison of the results obtained with both Weston and Clark cells with mercurous sulphate made by the different methods, Tables XVII and XVIII are given. These show the mean differences and the average deviations in microvolts from the mean of the reference cells for each set of samples. Only those cells are included which were under continuous observation for the whole period, with the exception of exchange cells and those set up with mercurous sulphate obtained from Professors Hulett and Guthe. The last column in each table gives the relative changes from the beginning to the end of the period covered, which, in the case of the Clark cells is only eight months, as most of them were set up in November, 1906. The number of Clark cells was also smaller on account of the breakage.

The largest change for the Weston cells, as shown in Table XVII, is found with the white samples of mercurous sulphate prepared in the old apparatus, and is no doubt partly to be accounted for by the somewhat high initial values of some of them, as in practically all the other cases where a slight decrease is also shown. Part of the

decrease may be due to the gradual leaching out of traces of sulphuric acid obstinately retained by the irregularly pitted crystals of mercurous sulphate. Although these changes are relative, an in-

TABLE XVII.

Summary of Results.

Weston Cells—Mean Differences and Average Deviations, in Microvolts, for Each Series of Mercurous Sulphate Samples.

Table	Method	No. Samples		July 20, '06		October 13, '06		January 10, '07		April 24, '07		July 23, '07		Relative Change in One Year
		No. Cells.	Mean	Ave. Deviation	Mean	Ave. Deviation	Mean	Ave. Deviation	Mean	Ave. Deviation	Mean	Ave. Deviation		
III	a	14	15	+28	31	+20	24	+10	17	+4	16	-1	16	-29
IV	b	17	28	+3	11	+1	10	0	10	-1	10	-3	10	-6
V	b	9	10	+12	14	+6	10	+1	7	+2	11	-1	12	-13
	c	1	1	+3	3	+4	4	-2	2	-7	7	-9	9	-12
VI	d	2	3	-5	14	-12	12	-12	12	-30	30	-31	31	-26
	e	5	8	-11	11	-12	12	-11	11	-15	15	-18	18	-7
	f	2	2	-9	9	-8	8	-6	6	-10	10	-14	14	-5
	g	2	3	+18	29	+7	22	+8	22	+6	19	+1	16	-17
	h	3	3	-10	12	-15	15	-16	16	-19	19	-22	22	-12
VII	i	2	2	+5	7	+2	4	0	6	-8	8	-11	11	-16
	k	6	6	+5	11	+5	12	+9	14	+5	13	-2	14	-7
	l	5	5	+32	32	+36	36	+35	35	+30	30	+14	29	-18
	m	4	4	+52	52	+60	60	+57	57	+52	52	+46	46	-6
	n	6	6	+74	74	+73	73	+77	77	+73	73	+67	67	-7

EXCHANGE SAMPLES.

IV	Hulett I.....	1	2	+32	32	+32	32	+36	36	+36	36	+33	33	+1
	Hulett II.....	1	2	0	4	-3	3
	Guthe.....	1	1	+25	25

EXCHANGE CELLS.

XIV & XV	Hulett.....	3	3	+40	40	+44	44	+41	41	+41	41	+1
	Guthe.....	1	1	4	4	-1	1	-3	3	-7
	Carhart.....	1	2	+6	6	+4	5	+2	5	-4
	Wold, '06.....	1	2	-15	15
	Wold, '07.....	4	6	¹ -14	20	² -12	18
Strong.....	-5	10	

¹ June 14, '07.

² June 29, '07.

spection of Table XVI will show that practically no change has taken place in the twelve Weston cells, chosen as standards, with reference to the corresponding Clark cells. This is also shown by the close agreement of duplicate Weston and Clark cells set up from time to time. (Tables III to XII.) One lot of the former, particularly those in Table III, set up June 28, 1907, show relatively large initial values,

TABLE XVIII.

Summary of Results.

Clark Cells—Mean Differences and Average Deviations, in Microvolts, for Each Series of Mercurous Sulphate Samples.

Table	Method	No. Samples	No. Cells	Dec. 1, '06		March 1, '07		May 24, '07		July 24, '07		Relative Change in Nine Months
				Mean	Ave. Deviation	Mean	Ave. Deviation	Mean	Ave. Deviation	Mean	Ave. Deviation	
VIII	a	10	12	+ 23	23	+ 18	18	+ 14	18	+ 16	16	- 7
IX	b	9	10	+ 4	7	+ 6	9	+ 9	9	+ 6	7	+ 2
X	b	4	4	+ 14	14	+ 12	13	+ 14	14	+ 13	13	- 1
XI	c	1	1	+ 8	8	+ 16	16	+ 17	17	+ 13	13	+ 5
	d	2	2	+ 8	8	+ 5	5	+ 7	7	+ 19	19	+11
	e	6	9	- 3	4	- 2	4	- 2	3	+ 1
	f	2	2	+ 4	4	+ 8	8	+ 9	9	+ 6	7	+ 2
	g	1	1	+ 17	17	- 3	3	+ 5	5	-12
XII	h	3	3	+ 1	10	0	9	0	9	+ 1	8	0
	i	2	2	- 2	2	- 3	3	- 1	1	- 4	4	- 2
	k	6	7	+ 24	25	+ 29	29	+ 28	28	+ 28	29	+ 4
	l	3	3	+ 51	51	+ 53	53	+ 51	51	+ 47	47	- 4
XIII	n	4	4	+ 71	71	+ 72	72	+ 70	70	+ 68	68	- 3
XIII	Old Specifications	5	8	+308	308	+305	305	+298	298	+282	282	-26

EXCHANGE SAMPLES.

IX	Hulett I	1	2	+ 43	43	+ 44	44	+ 46	46	+ 47	47	+ 4
	Hulett II	1	1	+ 19	19	+ 19	19	+ 18	18	- 1
	Guthe	1	1	+ 49	49

EXCHANGE CELLS.

XIV	Hulett	2	2	+ 12	12	+ 11	12
	Guthe	1	1	+ 58	58	+ 63	63
	Carhart	1	1	+ 44	44	- 18	18

but at the present time are in practical agreement with those set up twelve months before.

The relative changes in the Clark cells in the eight months are smaller than in the case of the Weston cells. Excluding those set up in accordance with the old specifications, the changes, which are both positive and negative, are less than 1 part in 100,000.

Size of grain.—In view of the work of von Steinwehr on the influence exerted upon the electromotive force by varying size of grain, efforts were made in some cases to obtain samples as coarse as possible, but the close agreement in both Clark and Weston cells of practically all the samples prepared by methods *a* to *k*, inclusive, shows that special precautions in this direction are hardly necessary. Many of the samples were examined under the microscope, and it was found that there were very few particles measuring less than one micron, the average dimensions being considerably greater. On the other hand, it is unnecessary to attempt to obtain very coarse-grained samples on account of the marked hysteresis, due to the small surface exposed to the solvent action of the electrolyte, as shown also by von Steinwehr.

The irregular pitted character of the crystals of all the samples of mercurous sulphate, which was mentioned above (p. 28), may explain, in part at least, the gradual decrease in the electromotive force of some of the cells, on account of the difficulty of completely removing the acid in which the sample was made and preserved.

A study has also been made of the electromotive differences of cadmium sulphate obtained from various makers or made directly from the "C. P." metal. Twenty cells, set up with clear and cloudy crystals, obtained by the recrystallization of 8 samples, from acid, neutral and basic solutions, show an average deviation from the mean of all of ± 9 microvolts and with a range of +28 and -26.

Further work has been done on the remaining materials and on other factors which might influence the electromotive force, i. e., the size of grain, depth of paste, influence of diffusion and influence of impurities. A determination of the temperature coefficients will also be made.

GENERAL CONCLUSIONS.

The principal conclusions to be drawn are—

1. That samples of mercurous sulphate of uniform electromotive properties can be prepared by a number of different methods.

2. The remaining materials used in the construction of standard cells can easily be obtained in an exceedingly pure state, and, besides, the ordinary impurities even in relatively large quantity, exert practically no influence on the electromotive force, so that Clark and Weston standard cells are reproducible to within 2 or 3 parts in 100,000.

3. When set up with proper materials the cells generally reach a practically constant value within a few days, and the electromotive force of both types can be depended on well within the above limits for at least one year.

4. The close agreement of the numerous samples prepared by different methods and under varying conditions shows that any effect due to size of grain may be disregarded.

5. The results obtained with exchange cells and samples of mercurous sulphate further establish the reproducibility of the cell.

6. Our experience with exchange cells, sent to and received from other investigators, shows that with ordinary precautions cells may be transported considerable distances without influencing the electromotive force.

7. The labor of preparing suitable materials for use in standard cells is much greater than the work of setting up the cells when all materials are ready. If these materials were to be furnished by the various national physical laboratories, standard cells could be set up by any investigator in a very short time, and the standard cell could well serve as one of the two *fundamental* electrical standards.

If the ampere as defined by the quantity of silver deposited per second were to be chosen as one of the two fundamental units (the ohm being the other), the standard cell would have to be depended upon between coulometer measurements to maintain the standard. Inasmuch as these measurements are somewhat laborious it is probable that they would be made quite infrequently. The standard cell has, however, shown itself to be sufficiently constant to justify trusting it for considerable periods, and if new cells set up occasionally agree with the old it would be necessary to resort to silver coulometer measurements only at considerable periods of time. This suggests, indeed, that the use of the silver coulometer as one of the two fundamental standards is of doubtful utility, as it seems improbable that it has sufficient advantage from the point of view of repro-

ducibility (if, indeed, it is as reproducible as the standard cell) to compensate for its greater inconvenience.

In the opinion of the authors the standard cell is to be preferred to the silver coulometer for another reason, namely, that practically all voltage and current measurements of precision are made by the potentiometer method, and thus directly in terms of the standard cell or a combination of a standard cell and a standard resistance.

The authors wish to acknowledge the valuable assistance rendered by Mr. M. P. Shoemaker, both in the preparation of the cells and in the electrical measurements.

APPENDIX.

REPORT ON STANDARD CELLS EXCHANGED WITH FOREIGN LABORATORIES.

On May 9, 1907, twelve Clark and twelve Weston cells, which had been set up at the Bureau of Standards and kept under observation for some time, were taken abroad by Dr. G. K. Burgess of this Bureau. They were carefully packed in tin cases after being separately wrapped in cotton and paraffined paper. The cans were carried by hand in a traveling bag, and kept in an upright position during transit. Rough weather was encountered for about three days, both on the outgoing and the return ocean passages. Six of the cells, three Clark and three Weston, were constructed with the aim of securing portability by the aid of an asbestos plug in each limb, held in place by a perforated glass tube fused to the cell walls.

Comparisons of all the cells were first made at the English National Physical Laboratory between May 25 and May 31, the Weston cells being compared with an equal number of cells of the same type, set up by Mr. F. E. Smith, four of which were kindly given the Bureau of Standards and four each to the Reichsanstalt and to Professor Mascart. The results show that the mean value of the Bureau Weston cells is less by three microvolts than the mean of the National Physical Laboratory cells with which they were compared. The results given in the tables were reduced to the Bureau basis of comparison by the aid of the measurements made

May 9 and August 22 on six of the Weston cells which were brought back to Washington.

According to a letter from Mr. Smith, the mean of all the Weston cells (more than 100) of the National Physical Laboratory is about 20 microvolts greater than the mean of the Bureau cells compared, so that the mean of all would be about 10 microvolts greater than the Bureau basis of reference, which, as stated above, is the mean of twelve Weston cells set up in May, 1906.

Eight of the Bureau Weston cells were next measured at the Laboratoire Central d'Électricité "under conditions which allowed an approximation to 1 part in 100,000." The maximum deviation of these cells from their mean was found to be 0.00002 volt, and the difference between this mean and the mean of the Weston standard cells of the Laboratoire Central was found to be of the order of 0.00001 volt. Eight of the English Weston cells compared under the same conditions showed a maximum deviation from their mean of about 0.00003 volt, and their mean differed from the mean of the Weston cells of the Laboratoire Central by about 0.00001 volt. A second set of comparisons, made at Paris in August and for which a formal report has not yet been received, confirms the first measurements on the Bureau cells, while four Weston cells constructed at the National Physical Laboratory had a mean electromotive force about 0.00003 volt greater than the mean of those of the Laboratoire Central d'Électricité. The above comparisons were made in kerosene baths which were stirred during the measurements. No temperature control was provided, so that the differences found may be partly accounted for by a slight hysteresis. Eight of the Weston cells of the Bureau and eight of the English cells were compared at Berlin, June 20 and 21, between the two comparisons at Paris. A preliminary report of the measurements made at Berlin has been received with the request to withhold publication for the present, so that the results of comparisons with the Reichsanstalt cells are omitted. We have, however, taken the liberty of calculating the relative values of the Bureau and the National Physical Laboratory cells to our basis of reference by the aid of measurements made May 9 and August 22 on Weston cells 105, P8, P9, P10, and 187, assuming the small rate of change in their mean to have been uniform in the interval. The comparisons at the National Physical Laboratory

were reduced in the same manner. Two Weston cells were kindly placed at the disposal of the Bureau by the Laboratoire Central d'Électricité and two by the Reichsanstalt.

Clark cells.—No measurements on the Clark cells were made at the Laboratoire Central d'Electricité. Those at the National Physical Laboratory showed a discrepancy in cells 35 and 28a, set up April 12, 1906, and November 23, 1906, respectively. As these measurements were not made in a thermostatically controlled bath, and as, in addition, the first measurements made on their return to Washington show similar differences, it is highly probable that the discrepancy of May 25–31 is due to hysteresis, which would be greater in the older cells, the others having been set up April 30, 1907. The comparisons made in Washington on May 9 on cells 35, 28a, 97, 98, 99, and 109, before their departure, and on August 22 on their return, show that the average change of the Clark cells has been even less than that of the Weston cells. The measurements made at London and Berlin were reduced to the Bureau basis in the same manner as described above for the Weston cells.

In the accompanying Tables XIX and XX, column 1 gives the numbers of the cells, column 2 the dates on which they were set up, columns 3, 4, 5, and 6 data in reference to the materials employed, and the remaining columns the differences in microvolts from the mean of twelve Weston cells and five Clark cells taken respectively as the basis of reference. The comparisons on May 9 and August 22 of the six Weston cells which had been measured at the three foreign laboratories show a mean decrease of six microvolts on their return to Washington, the change in only one cell exceeding ten microvolts. Practically all of the change of the cells set up April, 1907, is to be attributed to a small decrease frequently observed in cells newly set up, as is shown by check cells set up at the same time which remained in Washington. The Weston table includes the measurements on the exchange cells made immediately after their receipt at the Bureau. It will be noted that one of the cells of the National Physical Laboratory had a somewhat high initial value, but is rapidly approaching the mean of its companion cells.

The measurements on the two cells received from the Reichsanstalt are also given for the sake of completeness, although, on account

TABLE XIX.

Tabulation of Results.

Weston Cells—Differences in microvolts from mean of reference cells.

Cell	Date	Hg ₂ SO ₄	CdSO ₄	Cd-Amalg.	July 5, 1906	Sept. 13	Nov. 19	Jan. 10, 1907	Mar. 1	Mar. 25
19	June 22, '06	D=9.25 V=.5	Kahl.2 Cloudy	12½% Kahl. El.	- 9	- 7	- 7	- 4	- 8	- 7
105	June 27, '06	Lunge IV	"	"	-11	-16	-17	-15	-19	-18
					Apr. 23, 1907	Apr. 30	May 1	May 2	May 3	May 8
P8	April 13, '07	#1 Dec. 21, '06 1:6 H ₂ SO ₄ D=5.25	Kahl.3 Cloudy	12½% Kahl. El.	- 8	- 7	-10	- 8	- 3
P9	"		"	"	-13	-12	-13	-11	- 7
P10	"		"	"	-13	-12	-12	-11	- 7
¹ P11	"		"	"	- 9	- 8	- 9	- 7	- 4
¹ P12	"		"	"	-13	-12	-13	-11	- 6
¹ P13	"		"	"	-10	-11	-11	- 9	- 6
181	April 30, '07		#2 Dec. 21, '06 1:6 H ₂ SO ₄ D=5.25	"	"	+12	+ 8	+ 3	+ 4
182	"	"		"	+ 6	+ 3	0	+ 2	- 3
183	"	"		"	+ 5	+ 4	- 2	0	+ 4
184	"	"		"	+ 8	+ 7	+ 1	+ 3	+ 4
185	"	"		"	+ 6	+10	+ 5	+ 6	+ 5
186	"	"		"	- 1	- 2	- 8	- 5	- 2
187	"	"		"	+ 5	+ 4	+ 1	+ 3	+ 5
¹ 188	"	"		"	+ 4	+ 3	- 2	- 1	0
H26	Feb., '07	"Chemical precipitation"		Set up at the National Physical Laboratory						
C19	June, '06									
P53	Nov., '06									
P54	Nov., '06									
P55	Nov., '06									
C12	June, '06									
C117	June, '06									
H29	Feb., '07									
P210	Mar., '07									
H28	Feb., '07									
C17	June, '06									
P52	Nov., '06									
O 1	Paste disturbed in transit		Set up at Physikalisch-Technische Reichsanstalt							
O 2										
P.C.N.4			Set up at Laboratoire Central d'Électricité							
P.C.N.6										

¹ Cells which remained at the Bureau of Standards.

TABLE XIX.

Tabulation of Results.

Weston Cells—Differences in microvolts from mean of reference cells.

Cell	May 9	May 24	May 25-31 (London)	June 7	June 6-11 (Paris)	June 20-21 (Berlin)	Aug. 2	Aug. 22 ²	Aug. 22	Aug. 23	Aug. 26	Aug. 31	Sept. 17.
19	- 7	- 7	- 7	(-17)	-22	-23	-25	-30	-26
105	-19	-19	-18	(-17)	-22	-23	-25	-23	-17
P8	- 7	- 7	-10	(- 7)	-13	-12	-13	-15	- 7
P9	-10	-15	-12	(-10)	-16	-16	-16	-17	-15
P10	-10	- 8	-12	(-12)	-16	-16	-16	-17	-15
¹ P11	- 7	- 8	-10	-15	-15	-15	-15	-16	-13
¹ P12	- 9	-10	-11	-15	-15	-13	-14	-16	-12
¹ P13	- 9	-10	-13	-16	-16	-14	-16	-17	-15
181	- 2	- 8	} Left at National Physical Laboratory				
182	- 7	- 8						
183	- 7	- 6	0						
184	- 3	- 7	- 5	} Left at Physikalisch-Technische Reichsanstalt					
185	- 2	- 2						
186	- 9	- 9	} Left at the Laboratoire Central d'Électricité					
187	- 1	- 4	- 5						(- 5)
¹ 188	- 5	- 7	- 7	- 9	-10	- 9	-10	-10	- 7
H26	- 5	- 7	(+ 5)	- 4	-11	-16	-17	-15
C19	- 7	+ 6	(+78)	+36	+15	- 6	-12	-15
P53	- 8	0	(+ 3)	- 4	- 5	- 8	- 7	- 5
P54	- 8	0	(+ 2)	- 3	- 3	- 6	- 7	- 4
P55	- 8	0	} Left at Physikalisch-Technische Reichsanstalt				
C12	- 9	+ 1						
C117	- 8	+ 6						
H29	- 9	- 9						
P210	- 5	} Left at Laboratoire Central d'Électricité					
H28	- 3						
C17	- 4						
P52	- 5
0 1	(+338)	+246	+169	+90	+70	+47
0 2	(+ 93)	+ 86	+ 86	+78	+71	+63
P.C.N.4	(+ 8)	+ 5	+ 2	+ 4	+ 4	-10
P.C.N.6	(- 9)	- 25	- 28	-28	-30	-25

² Observations made ten minutes after cells had been put in bath. The values given represent the differences, in microvolts, between the individual cells and the mean of twelve cells of the same type taken as the basis of reference.

TABLE XX.

Tabulation of Results.

Clark Cells.—Differences in microvolts from mean of reference cells.

Cell	Date	Hg ₂ SO ₄	ZnSO ₄	Zn Amalg.	May 1, 1906	Aug. 4	Nov. 2	Jan. 10, 1907	Mar. 1	May 9
35	April 12, '06	D= 1 V=.75	Kahlbaum	10% Kahl. # 1	+ 4	+ 5	+ 5	+ 7	+ 8	+11
28a	Nov. 23, '06	D=.2 V=.5	"	"	+ 2	+ 3	+ 3
					May 1, 1907	May 2	May 3	May 7	May 8	May 9
97	April 30, '07	#2 Dec. 21, '06 1:6 H ₂ SO ₄ D=5.25	Baker crystals and solution	"	+ 7	+ 5	+ 4	+ 2	+ 3	+ 2
98	"			"	+ 5	+ 3	+ 4	+ 2	+ 2	+ 1
99	"			"	+ 9	+ 9	+10	+ 7	+ 7	+ 7
¹ 100	"			"	+ 9	+ 8	+ 6	+ 7	+ 5
¹ 101	"			"	+ 4	+14	+12	+ 8	+ 9	+ 9
103	"	"	"	+15	+15	+14	+16	+16	+11	
104	"	"	"	+ 8	+10	+ 9	+10	+11	+ 9	
105	"	"	"	+ 8	+ 8	+ 5	+ 5	+ 5	+ 2	
106	"	"	"	+10	+10	+ 9	+11	+11	+ 9	
107	"	"	"	+14	+14	+10	+10	+13	+10	
108	"	"	"	+ 3	+ 3	+ 1	+ 2	+ 4	+ 2	
109	"	"	"	+ 6	+ 9	+ 7	+ 7	+ 7	+ 8	
¹ 110	"	"	"	+13	+14	+12	+10	+11	+11	

¹Cells which remained at the Bureau of Standards.

TABLE XX.

Tabulation of Results.

Clark Cells.—Differences in microvolts from mean of reference cells.

Cell	May 24	May 25-31, (London)	June 4	June 6-11 (Paris)	June 12	June 20-21 (Berlin)	July 10	Aug. 2	Aug. 22 ²	Aug. 23	Aug. 26	Aug. 31	Sept. 17
35	(-53)	+9	(-15)	+3	+2	0	-1
28a	(-56)	-2	(-45)	-3	-3	-4	-5
97	+ 1	+9	(+ 4)	+5	+8	+6	+6
98	+ 4	+2	(+ 1)	+3	+6	+5	+5
99	+ 7	(+ 1)	-2	+1	+1	+2
¹ 100	+1	+1	0	-1	+ 1	+1	+1	0	0
¹ 101	+3	+6	+7	+8	+7	+ 9	+9	+9	+9	+8
103	+ 3	} Left at National Physical Laboratory				
104	+ 3					
105	+ 6	-8	} Left at Physikalisch-Technische Reichsanstalt				
106	+ 7	-6					
107	+ 5	} Left at Laboratoire Central d'Électricité				
108	+ 2					
109	+ 6	+2	(- 9)	+4	+7	+7	+6
¹ 110	+6	+8	+7	+8	+7	+ 9	+9	+9	+8	+8

² Measurements made within two hours after placing cells in bath. The values given represent the differences, in microvolts, between the individual cells and the mean of five cells of the same type taken as the basis of reference.

of the fact that the paste in both had evidently been disturbed in transit, they should not be considered as throwing any light on the question of reproducibility. The cells received from the Laboratoire Central d'Électricité show a most satisfactory agreement with the Bureau cells and with those received from the National Physical Laboratory.

The conclusions to be drawn are:

(1) That standard cells can be set up by different investigators with different materials which agree to within a few parts in 100,000.

(2) That standard cells can be constructed which show no appreciable change when carried considerable distances, even on ship-board, provided ordinary precautions are observed.

WASHINGTON, September 17, 1907.