



**NIST**

National Institute of  
Standards and Technology  
U.S. Department of Commerce

# Report of the 100th National Conference on Weights and Measures

as adopted by the 100th  
National Conference on Weights and Measures  
2015

**NIST Special  
Publication 1210**

This document is available free of charge from:  
<https://doi.org/10.6028/NIST.SP.1210>

INSIDE FRONT COVER - BLANK





# NIST Special Publication 1210

## Report of the 100<sup>th</sup> National Conference on Weights and Measures

*Philadelphia, Pennsylvania – July 19 through 23, 2015  
as adopted by the 100<sup>th</sup> National Conference on Weights and Measures 2015*

*Editors:*

Tina Butcher  
Linda Crown  
Richard Harshman  
David Sefcik  
Lisa Warfield

Dr. Douglas Olson, Chief  
*Office of Weights and Measures  
Physical Measurement Laboratory*

This publication is available free of charge from:  
<https://doi.org/10.6028/NIST.SP.1210>

March 2017



**U.S. Department of Commerce**  
*Wilbur L. Ross, Jr., Secretary*

**National Institute of Standards and Technology**  
*Kent Rochford, Acting NIST Director and Under Secretary of Commerce for Standards and Technology*

*The National Conference on Weights and Measures is supported by the National Institute of Standards and Technology and is attended by officials from various states, counties, and cities, as well as representatives from the U.S. Government, other nations, industry, and consumer organizations.*

Certain commercial entities, equipment, or materials may be identified in this document in order to describe an experimental procedure or concept adequately. Such identification is not intended to imply recommendation or endorsement by the National Institute of Standards and Technology, nor is it intended to imply that the entities, materials, or equipment are necessarily the best available for the purpose.

## Abstract

The 100<sup>th</sup> Annual Meeting of the National Conference on Weights and Measures (NCWM) was held July 19 -23, 2015, at the Sheraton Philadelphia Society Hill Hotel, Philadelphia, Pennsylvania. The theme of the meeting was “Weights and Measures: On the Path to Tomorrow.”

Reports by the NCWM Board of Directors, Standing Committees, and Special Purpose Committees constitute the major portion of this publication, along with the addresses delivered by Conference officials and other authorities from government and industry.

Special meetings included those of the Meter Manufacturers Association, Packaging and Labeling Subcommittee, Fuels and Lubricants Subcommittee, Associate Membership Committee, Regional Association Meetings, and Multipoint Calibration Task Group.

Key words: laws and regulations; legal metrology; meters; scales; specifications and tolerances; training; type evaluation; uniform laws; weights and measures.

**Note:** The policy of the National Institute of Standards and Technology is to use metric units of measurement in all of its publications. In this publication, however, recommendations received by the NCWM technical committees have been printed as they were submitted, and, therefore, may contain references to U.S. Customary Units where such units are commonly used in industry practice. Opinions expressed in non-NIST papers are those of the authors and not necessarily those of the National Institute of Standards and Technology. Non-NIST speakers are solely responsible for the content and quality of their material.

National Institute of Standards and Technology Special Publication 1210  
Natl. Inst. Stand. Technol. Spec. Pub. 1210, 850 pages (March 2017)  
<https://doi.org/10.6028/NIST.SP.1210>  
CODEN: NSPUE2

# National Conference on Weights and Measures

## Annual Report of the 100<sup>th</sup> NCWM

### Table of Contents

	<b>Page</b>
Abstract .....	ii
Past Chairman.....	v
Organizational Chart.....	ix
 <b>General Session</b>	
Address to the National Conference on Weights and Measures to Commemorate Their 100 <sup>th</sup> Meeting –	
Carol Hockert, NIST .....	GEN - 1
Chairman’s Address – Ronald Hayes, Missouri .....	GEN - 15
National Conference on Weights and Measures Keynote Address – N. David Smith, North Carolina.....	GEN - 23
Chairman Elect’s Address – Jerry Buendel, Washington .....	GEN - 31
Special Awards and Recognition	
NIST Recognition .....	GEN - 35
Present and Past NIST Employees in Attendance.....	GEN - 36
Measurement Canada Recognition .....	GEN - 36
Lifetime Achievement Award.....	GEN - 37
Distinguished Service Award.....	GEN - 37
Contribution Awards.....	GEN - 38
NCWM Retired Members Recognition .....	GEN - 39
NCWM Past Chairmen Recognition.....	GEN - 39
Attendance Award Certificate Recipients.....	GEN - 40
Door Prizes .....	GEN - 41
 <b>Standing Committee Reports</b>	
<b>Board of Directors (BOD).....</b>	<b>BOD-1</b>
Appendix A. Report of the Activities of the International Organization of Legal Metrology (OIML) and Regional Legal Metrology Organizations .....	BOD - A1
Appendix B. Associate Membership Committee (AMC) Agenda and Draft Meeting Minutes.....	BOD - B1
<b>Laws and Regulations Committee (L&amp;R) .....</b>	<b>L&amp;R - 1</b>
Appendix A. <b>Items 232-4 and 237-1:</b> NIST Handbook 130, Background and Justification for Handbook 130, Definition for “Diesel Gallon Equivalent (DGE)” of Compressed Natural Gas (CNG) and Liquefied Natural Gas (LNG) as a Vehicular Fuel .....	L&R - A1
Appendix B. <b>Item 260-2:</b> NIST Handbook 133, Section 2.7. Chitterling Test Procedures, How to Determine the Net Weight and Purge of Packaged Chitterlings Using, Executive Summary and Supporting Documentation.....	L&R - B1

Appendix C. **Items 232-3, 260-2, and 260-3:** NIST Handbook 133, Testing Packages of Animal Bedding and Peat Moss with Compressed/Expanded Volume Declarations, Executive Summary and Supporting Documentation.....L&R - C1

**Specifications and Tolerances Committee (S&T) ..... S&T - 1**

Appendix A. **Item 320-2:** NIST Handbook 44, UR.4.1. Maintenance of Equipment Background Information Provided by Mr. Henry Oppermann, Technical Director, Seraphin Test Measure Company, A Division of Pemberton Fabricators, Inc. .... S&T - A1

Appendix B. **Item 320-1, 324-1, 330-1, and 360-1:** NIST Handbook 44, Belt-Conveyor Scale Systems; Liquid Measuring Devices; and Definitions – Comments by Henry Oppermann, Weights and Measures Consulting..... S&T - B1

Appendix C. **Item 320-4:** Draft Tentative Code Applicable to Weigh-In-Motion Systems Used for Vehicle Enforcement Screening ..... S&T - C1

Appendix D. **Item 330-4:** NIST Handbook 44 N.4.2.5. Determination of Error on Whole Sale Devices with Multiple Flow Rates and Calibration Factors ..... S&T - D1

Appendix E. **Items 331-2:** NIST Handbook 44, N.4.2.1. Determination of Error on Vehicle-Tank Meters with Multiple Flow Rates and Calibration Factors ..... S&T - E1

Appendix F. **Item 337-1:** NIST Handbook 44, Submitters Background and Justification for Handbook 44 Definition of “Diesel Gallon Equivalent (DGE)” of Compressed Natural Gas (CNG) and “Liquefied Natural Gas (LNG)” as a Vehicular Fuel .....S&T - F1

Appendix G. **Item 337-1:** NIST Handbook 44, OWM’s Technical Analysis of Item 337-1 ..... S&T - G1

Appendix H. **Item 360-5:** NIST Handbook 44, Electric Vehicle Fueling and Submetering Draft Code..... S&T - H1

Appendix I. **Item 360-5:** NIST Handbook 44, Electric Vehicle Fueling and Submetering/ Amendments to Timing Devices Code .....S&T - I1

**Professional Development Committee (PDC) ..... PDC - 1**

Appendix A. Safety Awareness Presentation ..... PDC - A1

**National Type Evaluation Program Program (NTEP) Committee.....NTEP - 1**

Appendix A. NTEP Statistics Report .....NTEP - A1

Appendix B. Belt-Conveyor Scale Sector Meeting Summary ..... NTEP - B1

Appendix C. Grain Analyzer Sector Meeting Summary ..... NTEP - C1

Appendix D. Measuring Sector Annual Meeting Summary.....NTEP - D1

Appendix E. Software Sector Meeting Summary ..... NTEP - E1

Appendix F. Weighing Sector Meeting Summary..... NTEP - F1

Appendix G. Multiple Dimension Measuring Devices Work Group Meeting Summary..... NTEP - G1

**Nominating Committee .....NOM - 1**

**Attendees ..... ATTEND - 1**

This publication is available free of charge from: <https://doi.org/10.6028/NIST.SP.1210>

### Past Chairmen of the Conference

Conference	Year	Location	Chairman
1 <sup>st</sup>	1905	Washington, D.C.	Dr. S. W. Stratton, Bureau of Standards
2 <sup>nd</sup>	1906	Washington, D.C.	Dr. S. W. Stratton, Bureau of Standards
3 <sup>rd</sup>	1907	Washington, D.C.	Dr. S. W. Stratton, Bureau of Standards
4 <sup>th</sup>	1908	Washington, D.C.	Dr. S. W. Stratton, Bureau of Standards
	1909	Conference Not Held	
5 <sup>th</sup>	1910	Washington, D.C.	Dr. S. W. Stratton, Bureau of Standards
6 <sup>th</sup>	1911	Washington, D.C.	Dr. S. W. Stratton, Bureau of Standards
7 <sup>th</sup>	1912	Washington, D.C.	Dr. S. W. Stratton, Bureau of Standards
8 <sup>th</sup>	1913	Washington, D.C.	Dr. S. W. Stratton, Bureau of Standards
9 <sup>th</sup>	1914	Washington, D.C.	Dr. S. W. Stratton, Bureau of Standards
10 <sup>th</sup>	1915	Washington, D.C.	Dr. S. W. Stratton, Bureau of Standards
11 <sup>th</sup>	1916	Washington, D.C.	Dr. S. W. Stratton, Bureau of Standards
	1917	Conference Not Held	
	1918	Conference Not Held	
12 <sup>th</sup>	1920	Washington, D.C.	Dr. S. W. Stratton, Bureau of Standards
13 <sup>th</sup>	1921	Washington, D.C.	Dr. S. W. Stratton, Bureau of Standards
14 <sup>th</sup>	1922	Washington, D.C.	Dr. S. W. Stratton, Bureau of Standards
15 <sup>th</sup>	1923	Washington, D.C.	Dr. George Burgess, Bureau of Standards
16 <sup>th</sup>	1924	Washington, D.C.	Dr. George Burgess, Bureau of Standards
17 <sup>th</sup>	1925	Washington, D.C.	Dr. George Burgess, Bureau of Standards
18 <sup>th</sup>	1926	Washington, D.C.	Dr. George Burgess, Bureau of Standards
19 <sup>th</sup>	1927	Washington, D.C.	Dr. George Burgess, Bureau of Standards
20 <sup>th</sup>	1928	Washington, D.C.	Dr. George Burgess, Bureau of Standards
21 <sup>st</sup>	1928	Washington, D.C.	Dr. George Burgess, Bureau of Standards
22 <sup>nd</sup>	1929	Washington, D.C.	Dr. George Burgess, Bureau of Standards
23 <sup>rd</sup>	1930	Washington, D.C.	Dr. George Burgess, Bureau of Standards
24 <sup>th</sup>	1931	Washington, D.C.	Dr. George Burgess, Bureau of Standards
	1932	Conference Not Held	
	1933	Conference Not Held	
	1934	Conference Not Held	
25 <sup>th</sup>	1935	Washington, D.C.	Dr. Lyman Briggs, National Bureau of Standards
26 <sup>th</sup>	1936	Washington, D.C.	Dr. Lyman Briggs, National Bureau of Standards
27 <sup>th</sup>	1937	Washington, D.C.	Dr. Lyman Briggs, National Bureau of Standards
28 <sup>th</sup>	1938	Washington, D.C.	Dr. Lyman Briggs, National Bureau of Standards

Conference	Year	Location	Chairman
29 <sup>th</sup>	1939	Washington, D.C.	Dr. Lyman Briggs, National Bureau of Standards
30 <sup>th</sup>	1940	Washington, D.C.	Dr. Lyman Briggs, National Bureau of Standards
31 <sup>st</sup>	1941	Washington, D.C.	Dr. Lyman Briggs, National Bureau of Standards
	1942	Conference Not Held	
	1943	Conference Not Held	
	1944	Conference Not Held	
	1945	Conference Not Held	
32 <sup>nd</sup>	1946	Washington, D.C.	Dr. E. U. Condon, National Bureau of Standards
33 <sup>rd</sup>	1947	Washington, D.C.	Dr. E. U. Condon, National Bureau of Standards
	1948	Conference Not Held	
34 <sup>th</sup>	1949	Washington, D.C.	Dr. E. U. Condon, National Bureau of Standards
35 <sup>th</sup>	1950	Washington, D.C.	Dr. E. U. Condon, National Bureau of Standards
36 <sup>th</sup>	1951	Washington, D.C.	Dr. E. U. Condon, National Bureau of Standards
37 <sup>th</sup>	1952	Washington, D.C.	Dr. E. U. Condon, National Bureau of Standards
38 <sup>th</sup>	1953	Washington, D.C.	Dr. E. U. Condon, National Bureau of Standards
39 <sup>th</sup>	1954	Washington, D.C.	Dr. E. U. Condon, National Bureau of Standards
40 <sup>th</sup>	1955	Washington, D.C.	Dr. E. U. Condon, National Bureau of Standards
41 <sup>st</sup>	1956	Washington, D.C.	Dr. A. V. Astin, National Bureau of Standards
42 <sup>nd</sup>	1957	Washington, D.C.	Dr. A. V. Astin, National Bureau of Standards
43 <sup>rd</sup>	1958	Washington, D.C.	J. P. McBride, MA
44 <sup>th</sup>	1959	Washington, D.C.	C. M. Fuller, CA
45 <sup>th</sup>	1960	Washington, D.C.	H. E. Crawford, FL
46 <sup>th</sup>	1961	Washington, D.C.	R. E. Meek, IN
47 <sup>th</sup>	1962	Washington, D.C.	R. Williams, NY
48 <sup>th</sup>	1963	Washington, D.C.	C. H. Stender, SC
49 <sup>th</sup>	1964	Washington, D.C.	D. M. Turnbull, WA
50 <sup>th</sup>	1965	Washington, D.C.	V. D. Campbell, OH
51 <sup>st</sup>	1966	Denver, CO	J. F. True, KS
52 <sup>nd</sup>	1967	Washington, D.C.	J. E. Bowen, MA
53 <sup>rd</sup>	1968	Washington, D.C.	C. C. Morgan, IN
54 <sup>th</sup>	1969	Washington, D.C.	S. H. Christie, NJ
55 <sup>th</sup>	1970	Salt Lake City, UT	R. W. Searles, OH
56 <sup>th</sup>	1971	Washington, D.C.	M. Jennings, TN
57 <sup>th</sup>	1972	Washington, D.C.	E. H. Black, CA
58 <sup>th</sup>	1973	Minneapolis, MN	G. Johnson, KY
59 <sup>th</sup>	1974	Washington, D.C.	J. Lewis, WA
60 <sup>th</sup>	1975	San Diego, CA	S. Andrews, FL



Conference	Year	Location	Chairman
61 <sup>st</sup>	1976	Washington, D.C.	R. Thompson, MD
62 <sup>nd</sup>	1977	Dallas, TX	E. Prideaux, CO
63 <sup>rd</sup>	1978	Washington, D.C.	J. Lyles, WA
64 <sup>th</sup>	1979	Portland, OR	K. Simila, OR
65 <sup>th</sup>	1980	Washington, D.C.	C. Vincent, TX
66 <sup>th</sup>	1981	St. Louis, MO	E. Stadolnik, MA
67 <sup>th</sup>	1982	Atlanta, GA	E. Heffron, MI
68 <sup>th</sup>	1983	Sacramento, CA	C. Greene, NM
69 <sup>th</sup>	1984	Boston, MA	S. Hindsman, AR
70 <sup>th</sup>	1985	Washington, D.C.	E. Delfino, CA
71 <sup>st</sup>	1986	Albuquerque, NM	G. Mattimoe, HI
72 <sup>nd</sup>	1987	Little Rock, AR	F. Nagele, MI
73 <sup>rd</sup>	1988	Grand Rapids, MI	D. Guensler, CA
74 <sup>th</sup>	1989	Seattle, WA	J. Bartfai, NY
75 <sup>th</sup>	1990	Washington, D.C.	F. Gerk, NM
76 <sup>th</sup>	1991	Philadelphia, PA	N. D. Smith, NC
77 <sup>th</sup>	1992	Nashville, TN	S. Colbrook, IL
78 <sup>th</sup>	1993	Kansas City, MO	A. Nelson, CT
79 <sup>th</sup>	1994	San Diego, CA	T. Geiler, MA
80 <sup>th</sup>	1995	Portland, ME	J. Truex, OH
81 <sup>st</sup>	1996	New Orleans, LA	C. Gardner, NY
82 <sup>nd</sup>	1997	Chicago, IL	B. Bloch, CA
83 <sup>rd</sup>	1998	Portland, OR	S. Malone, NE
84 <sup>th</sup>	1999	Burlington, VT	A. Thompson, AK
85 <sup>th</sup>	2000	Richmond, VA	W. Diggs, VA
86 <sup>th</sup>	2001	Washington, D.C.	L. Straub, MD
87 <sup>th</sup>	2002	Cincinnati, OH	R. Murdock, NC
88 <sup>th</sup>	2003	Sparks, NV	R. Andersen, NY
89 <sup>th</sup>	2004	Pittsburgh, PA	D. Ehrhart, AZ
90 <sup>th</sup>	2005	Orlando, FL	W. Diggs, VA
91 <sup>st</sup>	2006	Chicago, IL	D. Onwiler, NE
92 <sup>nd</sup>	2007	Salt Lake City, UT	M. Cleary, CA
93 <sup>rd</sup>	2008	Burlington, VT	J. Cardin, WI
94 <sup>th</sup>	2009	San Antonio, TX	J. Kane, MT
95 <sup>th</sup>	2010	St. Paul, MN	R. Jennings, TN
96 <sup>th</sup>	2011	Missoula, MT	T. Tyson, KS
97 <sup>th</sup>	2012	Portland, ME	K. Floren, CA

<b>Conference</b>	<b>Year</b>	<b>Location</b>	<b>Chairman</b>
98 <sup>th</sup>	2013	Louisville, KY	S. Benjamin, NC
99 <sup>th</sup>	2014	Detroit, MI	J. Gaccione, Westchester County, NY
100 <sup>th</sup>	2015	Philadelphia, PA	R. Hayes, MO

## 2014 – 2015 Organizational Chart



<b>NCWM Board of Directors</b>			
<b>OFFICE</b>	<b>NAME</b>	<b>AFFILIATION</b>	<b>TERM ENDS</b>
Chairman	Ronald Hayes	Missouri	2015
Chairman-Elect	Jerry Buendel	Washington	2015
NTEP Committee Chair	John Gaccione	Westchester County, New York	2015
Treasurer	Mark Coyne	City of Brockton, Massachusetts	2015
Active Membership – Central	Craig VanBuren	Michigan	2015
Active Membership – Western	Brett Gurney	Utah	2017
Active Membership – Southern	Kenneth Ramsburg	Maryland	2018
Active Membership – Northeastern	James Cassidy	City of Cambridge, Massachusetts	2019
At-Large	Chuck Corr	Archer Daniels Midland Company	2018
At-Large	Steve Giguere	Maine	2016
Associate Membership	Christopher Guay	Procter and Gamble, Co.	2016
Honorary NCWM President	Dr. Willie May	NIST Director	NA
Executive Secretary	Carol Hockert	NIST, Office of Weights and Measures	NA
Executive Director	Don Onwiler	NCWM	NA
Board of Directors Advisor	Gilles Vinet	Measurement Canada	NA
NTEP Administrator	Jim Truex	NCWM	NA
Chairman	Ronald Hayes	Missouri	2015
Chairman-Elect	Jerry Buendel	Washington	2015
NTEP Committee Chair	John Gaccione	Westchester County, New York	2015
Treasurer	Mark Coyne	City of Brockton, Massachusetts	2015
Active Membership – Central	Craig VanBuren	Michigan	2015
Active Membership – Western	Brett Gurney	Utah	2017
<b>National Type Evaluation Program Committee (NTEP)</b>			
<b>OFFICE</b>	<b>NAME</b>	<b>AFFILIATION</b>	<b>TERM ENDS</b>
Chair	John Gaccione	Westchester County, New York	2015
Member	Ronald Hayes	Missouri	2016
Member	Jerry Buendel	Washington	2017
Member	Kenneth Ramsburg	Maryland	2018
Member	James Cassidy	Massachusetts	2019
NTEP Administrator	Jim Truex	NCWM	NA
Chair	John Gaccione	Westchester County, New York	2015

Organizational Chart – 2015 Final Report

Member	Ronald Hayes	Missouri	2016
Member	Jerry Buendel	Washington	2017
<b>Finance Committee</b>			
<b>OFFICE</b>	<b>NAME</b>	<b>AFFILIATION</b>	<b>TERM ENDS</b>
Chair	Jerry Buendel	Washington	2015
Nominated Chair-Elect	Kristin Macey	California	2016
Member	Mark Coyne	City of Brockton, Massachusetts	2015
Member	Christopher Guay	Procter and Gamble, Co.	2016
Executive Director	Don Onwiler	NCWM	NA
<b>Laws and Regulations (L&amp;R)</b>			
<b>OFFICE</b>	<b>NAME</b>	<b>AFFILIATION</b>	<b>TERM ENDS</b>
Committee Chair	Tim Lloyd	Montana	2015
Member	Richard Lewis	Georgia	2016
Member	Louis Sakin	Towns of Hopkinton/Northbridge, Massachusetts	2017
Member	John Albert	Missouri	2018
Member	Kristin Macey	California	2019
Associate Membership Representative	Steve Grabski	Wal-Mart Stores, Inc.	2018
Canadian Technical Advisor	Lance Robertson	Measurement Canada	NA
NIST Technical Advisor	David Sefcik	NIST, Office of Weights and Measures	NA
NIST Technical Advisor	Lisa Warfield	NIST, Office of Weights and Measures	NA
<b>Professional Development Committee (PDC)</b>			
<b>OFFICE</b>	<b>NAME</b>	<b>AFFILIATION</b>	<b>TERM ENDS</b>
Committee Chair	Cheryl Ayer	New Hampshire	2015
Member	Angela Godwin	Ventura County, California	2016
Member	Stacy Carlsen	Marin County, California	2017
Member	Julie Quinn	Minnesota	2018
Member	Doug Killingsworth	Georgia	2019
Associate Membership Representative	Richard Shipman	Rice Lake Weighing Systems	2018
Safety Liaison	TBD		NA
NIST Liaison	Tina Butcher	NIST, Office of Weights and Measures	NA
Certification Coordinator	Ross Andersen	Retired	NA
<b>Specifications and Tolerances Committee (S&amp;T)</b>			
<b>OFFICE</b>	<b>NAME</b>	<b>AFFILIATION</b>	<b>TERM ENDS</b>
Committee Chair	Mahesh Albuquerque	Colorado	2016
Member	Rachelle Miller	Wisconsin	2015
Member	Jane Zulkiewicz	Town of Barnstable	2017
Member	Matthew Curran	Florida	2018

Member	Ivan Hankins	Iowa	2019
Canadian Technical Advisor	Luciano Burtini	Measurement Canada	NA
NIST Technical Advisor	Clark Cooney	NIST, Office of Weights and Measures	NA
NIST Technical Advisor	Rick Harshman	NIST, Office of Weights and Measures	NA
NTEP Specialist	Darrell Flocken	NCWM	NA
Committee Chair	Mahesh Albuquerque	Colorado	2016
<b>Nominating Committee</b>			
<b>OFFICE</b>	<b>NAME</b>	<b>AFFILIATION</b>	<b>TERM ENDS</b>
Committee Chair	John Gaccione	Westchester County, New York	2015
Member	Stephen Benjamin	North Carolina	2015
Member	Judy Cardin	Wisconsin	2015
Member	Charles Carroll	Massachusetts	2015
Member	Kurt Floren	Los Angeles County	2015
Member	Joe Gomez	New Mexico	2015
Member	Randy Jennings	Tennessee	2015
<b>Credentials Committee</b>			
<b>OFFICE</b>	<b>NAME</b>	<b>AFFILIATION</b>	<b>TERM ENDS</b>
Committee Chair	Craig VanBuren	Michigan	2015
Member	Fran Elson-Houston	Ohio	2016
Member	Ethan Bogren	Westchester County, New York	2017
Coordinator	Darrell Flocken	NCWM	NA
<b>Appointive Officials</b>			
<b>OFFICE</b>	<b>NAME</b>	<b>AFFILIATION</b>	<b>TERM ENDS</b>
Chaplain	Stephen Langford	Cardinal Scale Manufacturing, Co.	2015
Parliamentarian	Louis Straub	Fairbanks Scale, Inc.	2015
Presiding Officer	Tim Chesser	Arkansas	2015
Presiding Officer	Marco Mares	San Diego County, California	2015
Presiding Officer	Laurence Nolan	Los Angeles County, California	2015
Presiding Officer	Jack Walsh	Town of Wellesley, Massachusetts	2015
Sergeants-at-Arms	Michael McGoff	Pennsylvania	2015
Sergeants-at-Arms	Doug Rudy	Pennsylvania	2015
Poet Laureate	Ivan Hankins	Iowa	2015

<b>Associate Membership Committee</b>			
<b>OFFICE</b>	<b>NAME</b>	<b>AFFILIATION</b>	<b>TERM ENDS</b>
Chair	Bill Callaway	Crompco	2015
Vice-Chair	David Calix	NCR Corporation	2015
Secretary/Treasurer	Richard Shipman	Rice Lake Weighing Systems, Inc.	2015
Member	Richard Shipman	Rice Lake Weighing Systems, Inc.	2015
Member	Steven Grabski	Walmart Stores, Inc.	2015
Member	Christopher Guay	Procter and Gamble, Co.	2015
Member	Thomas McGee	PMP Corporation	2015
Member	Rob Underwood	Petroleum Marketers Association of America	2015
Member	David Calix	NCR Corporation	2018
Member	Bill Callaway	Crompco	2018
Member	Robert Murnane, Jr.	Seraphin Test Measure	2018
Member	Paul A. Lewis, Sr.	Rice Lake Weighing Systems, Inc.	2019
<b>Fuels and Lubricants Subcommittee (FALS)</b>			
<b>OFFICE</b>	<b>NAME</b>	<b>AFFILIATION</b>	
Chair	Matthew Curran	Florida	
Vice-Chair	Ronald Hayes	Missouri	
Vice-Chair	Randy Jennings	Tennessee	
Secretary	Kelly Davis	Renewable Fuels Association	
Vice-Secretary	Rebecca Richardson	MARC IV Consulting	
NIST Technical Advisor	Kenneth Butcher	NIST, Office of Weights and Measures	
NIST Technical Advisor	David Sefcik	NIST, Office of Weights and Measures	
NIST Technical Advisor	Lisa Warfield	NIST, Office of Weights and Measures	
Public Sector Member	Mahesh Albuquerque	Colorado	
Public Sector Member	Stephen Benjamin	North Carolina	
Public Sector Member	Kristin Macey	California	
Public Sector Member	Bill Striejewske	Nevada	
Public Sector Member	Timothy White	Michigan	
Public Sector Member	Michelle Wilson	Arizona	
Private Sector Member	Bill Cannella	Chevron Global Downstream, LLC	
Private Sector Member	Chuck Corr	Archer Daniels Midland Company	
Private Sector Member	Dayne Delahoussaye	Neste Oil	
Private Sector Member	Kevin Ferrick	API	
Private Sector Member	Rick Fragnito	Shell	
Private Sector Member	K.W. Gardner	ExxonMobil Corporation	
Private Sector Member	Bill Geubelle	Phillips 66	
Private Sector Member	Philip Guillemette	Flint Hills Resources, LP	
Private Sector Member	John Harkins	Sunoco, Inc.	



Private Sector Member	Marilyn Herman	Herman and Associates
Private Sector Member	Joanna Johnson	Automotive Oil Exchange Association
Private Sector Member	Patrick Kelly	API
Private Sector Member	David A. Kovach	BP Products
Private Sector Member	Roger Leisenring, Jr.	KiOR
Private Sector Member	Russ Lewis	Marathon Petroleum, LLC
Private Sector Member	Michael Lynch	ExxonMobil Corporation
Private Sector Member	James McGetrick	BP Products
Private Sector Member	Manuch Nikanjam	Chevron Global Downstream, LLC
Private Sector Member	Keith Penn	Colonial Pipeline Company
Private Sector Member	Derek Regal	Tesoro Companies, Inc.
Private Sector Member	Prentiss Searles	American Petroleum Institute
Private Sector Member	Brad Stotler	NATSO
Private Sector Member	William Studzinski	General Motors
Private Sector Member	Rob Underwood	Petroleum Marketers Association of America
Private Sector Member	Marie Valentine	Toyota-TEMA-TTC
Private Sector Member	Curtis Williams	CP Williams Energy Consulting, LLC
Private Sector Member	William Woebkenberg	Mercedes-Benz Research and Development NA
<b>Packaging and Labeling Subcommittee (PALS)</b>		
<b>OFFICE</b>	<b>NAME</b>	<b>AFFILIATION</b>
Chair	Christopher Guay	Procter and Gamble, Co.
NIST Technical Advisor	David Sefcik	NIST, Office of Weights and Measures
Public Sector – Central	Nicholas Owens	Stark County Weights and Measures
Public Sector - Northeastern	Frank Greene	Connecticut
Public Sector – Southern	Hal Prince	Florida
Public Sector - Western	Angela Godwin	County of Ventura
Private Sector Member	Ann Boeckman	Kraft Food Group, Inc.
Private Sector Member	Krister Hard af Segerstad	IKEA North America Services, LLC
Private Sector Member	Zina Juroch	Pier 1 Imports
Private Sector Member	Stratt Pinagel	Walmart Stores, Inc.
<b>Natural Gas Steering Committee</b>		
<b>OFFICE</b>	<b>NAME</b>	<b>AFFILIATION</b>
Chair	Ethan Bogren	Westchester County, New York
Vice-Chair	Raymond Johnson	New Mexico
NIST Technical Advisor	Juana Williams	NIST Office of Weights and Measures
Public Sector – Central	Ronald Hayes	Missouri
Public Sector – Southern	Matthew Curran	Florida
Public Sector – Western	Mahesh Albuquerque	Colorado
Public Sector Member	G. Diane Lee	NIST, Office of Weights and Measures
Private Sector Member	Brett Barry	Clean Energy
Private Sector Member	Josh Brown	NorthStar, Inc.

Private Sector Member	Jeffrey L. Clarke	NGV America
Private Sector Member	Scott Hartman	Shell
Private Sector Member	Douglas Horne	Clean Vehicle Education Foundation
Private Sector Member	David Jaskolski	Pivotal LNG
Private Sector Member	Gordon Johnson	Gilbarco, Inc.
Private Sector Member	Dmitri Karimov	Liquid Controls
Private Sector Member	Randy Moses	Wayne
Private Sector Member	Prentiss Searles	American Petroleum Institute

#### Promotional Tool Kit Task Group

OFFICE	NAME	AFFILIATION
Chair	Stephen Benjamin	North Carolina
Public Sector Member	Kurt Floren	Los Angeles County
Public Sector Member	Jerry Buendel	Washington
Private Sector Member	Henry Oppermann	Weights and Measures Consulting
Private Sector Member	John Hughes	Rice Lake Weighing Systems

#### Organometallics Task Group

OFFICE	NAME	AFFILIATION
Chair	Randy Jennings	Tennessee
Public Sector Member	Ronald Hayes	Missouri
Public Sector Member	Bill Striejewski	Nevada
Private Sector Member	John Cabaniss	Global Automakers
Private Sector Member	Marilyn Herman	Herman and Associates
Private Sector Member	Jeff Jetter	Honda R&D Americas, Inc.
Private Sector Member	Russ Lewis	Marathon Petroleum
Private Sector Member	James McGetrick	BP
Private Sector Member	Mike Meffert	Afton Chemical
Private Sector Member	Kristy Moore	Renewable Fuels Foundation
Private Sector Member	Derek Regal	Tesoro Chemical
Private Sector Member	Charles Richardson	Ford Motor Company
Private Sector Member	Jenny Sigelko	Volkswagen Group of America
Private Sector Member	Val Ughetta	Alliance of Automobile Manufacturers

#### Multiple Dimensions Measuring Device Work Group

OFFICE	NAME	AFFILIATION
Chair	Robert Kennington	Quantronix, Inc.
NIST Technical Advisor	Rick Harshman	NIST, Office of Weights and Measures
NTEP Administrator	Jim Truex	NCWM
NTEP Specialist	Darrell Flocken	NCWM
Public Sector Member	Tom Buck	Ohio
Public Sector Member	Fran Elson-Houston	Ohio

Public Sector Member	Justin Rae	Measurement Canada
Public Sector Member	Isabelle Tremblay	Measurement Canada
Public Sector Member	Pascal Turgeon	Measurement Canada, Policy/Regulations Group
Private Sector Member	Sprague Ackley	Honeywell
Private Sector Member	Scott Davidson	Mettler-Toledo, LLC
Private Sector Member	Michael Eichenberg	FreightSnap, LLC
Private Sector Member	Dev Goyal	SICK, Inc.
Private Sector Member	Jim Larson	United Parcel Service
Private Sector Member	Uwe Mohr	Vitronic
Private Sector Member	Jack Pangrazio	LTS Scale Company, LLC
Private Sector Member	Tony Romeo	Datalogic
Private Sector Member	Richard Shipman	Rice Lake Weighing Systems
Private Sector Member	Mike Stutler	United Parcel Service
Private Sector Member	Richard Suiter	Richard Suiter Consulting
Private Sector Member	Russ Vires	Mettler-Toledo, LLC
Private Sector Member	Scott Wigginton	United Parcel Service

<b>NTEP Belt-Conveyor Sector</b>		
<b>OFFICE</b>	<b>NAME</b>	<b>AFFILIATION</b>
Chair	Peter Sirrico	Thayer Scale / Hyer Industries
Technical Advisor	John Barton	NIST, Office of Weights and Measures
NTEP Administrator	Jim Truex	NCWM
NTEP Specialist	Darrell Flocken	NCWM
Public Sector Member	Tina Butcher	NIST, Office of Weights and Measures
Public Sector Member	Zacharias Tripoulas	Maryland
Public Sector Member	Thomas Vormittag	Nevada
Private Sector Member	Rafael Jimenez	Association of American Railroads Transportation Technology Center, Inc.
Private Sector Member	Jason Kukachka	Thermo Fisher Scientific
Private Sector Member	Lars Marmsater	Merrick Industries, Inc.
<b>NTEP Grain Analyzer Sector</b>		
<b>OFFICE</b>	<b>NAME</b>	<b>AFFILIATION</b>
Chair	Karl Cunningham	Illinois
NIST Technical Advisor	G. Diane Lee	NIST, Office of Weights and Measures
NTEP Administrator	Jim Truex	NCWM
NTEP Specialist	Darrell Flocken	NCWM
Public Sector Member	Tina Butcher	NIST, Office of Weights and Measures
Public Sector Member	Randy Burns	Arkansas
Public Sector Member	Rick Dempster	USDA, GIPSA Technical Services Division
Public Sector Member	Cassie Eigenmann	DICKEY-john Corporation
Public Sector Member	Ivan Hankins	Iowa
Public Sector Member	Thomas Hughes	Missouri
Private Sector Member	Jeffrey Adkisson	Grain and Feed Association of Illinois
Private Sector Member	James Bair	North American Miller's Association
Private Sector Member	Rachel Beiswenger	TSI Incorporated
Private Sector Member	Martin Clements	The Steinlite Corporation
Private Sector Member	Kathy Conover	DICKEY-john Corporation
Private Sector Member	Andrew Gell	Foss North America
Private Sector Member	Charles Hurburgh, Jr.	Iowa State University
Private Sector Member	Jess McCluer	National Grain and Feed Association
Private Sector Member	Thomas Runyon	Seedburo Equipment Co.

<b>NTEP Measuring Sector</b>		
<b>OFFICE</b>	<b>NAME</b>	<b>AFFILIATION</b>
Chair	Michael Keilty	Endress + Hauser Flowtec AG, USA
NIST Technical Advisor	Clark Cooney	NIST, Office of Weights and Measures
NTEP Administrator	Jim Truex	NCWM
NTEP Specialist	Darrell Flocken	NCWM
Public Sector Member	Luciano Burtini	Measurement Canada
Public Sector Member	Tina Butcher	NIST, Office of Weights and Measures
Public Sector Member	Allen Katalinic	North Carolina
Public Sector Member	John Roach	California
Private Sector Member	Steve Bar	Bennett Pump Company
Private Sector Member	William Cooper	Tuthill Transfer Systems
Private Sector Member	Constantine Cotsoradis	Flint Hills Resources
Private Sector Member	Ronnell Gallon	Zenner Performance Meters, Inc.
Private Sector Member	Paul Glowacki	Murray Equipment, Inc.
Private Sector Member	Gordon Johnson	Gilbarco, Inc.
Private Sector Member	Dmitri Karimov	Liquid Controls
Private Sector Member	Yefim Katselnik	Wayne Fueling Systems
Private Sector Member	Douglas Long	RDM Industrial Electronics
Private Sector Member	Andrew MacAllister	Daniel Measurement and Control
Private Sector Member	Wade Mattar	Invensys / Foxboro
Private Sector Member	Richard Miller	FMC Technologies Measurement Solutions, Inc.
Private Sector Member	Donald Mundorff	Badger Meter Scottsdale
Private Sector Member	Andre Noel	Neptune Technology Group, Inc.
Private Sector Member	Johnny Parrish	Brodie International
Private Sector Member	Dan Peterson	Yokogawa Corporation of America
Private Sector Member	Richard Tucker	RL Tucker Consulting, LLC

<b>NTEP Software Sector</b>		
<b>OFFICE</b>	<b>NAME</b>	<b>AFFILIATION</b>
Chair	James Pettinato	FMC Technologies Measurement Solutions, Inc.
Secretary	Teri Gulke	Liquid Controls, LLC
Technical Advisor	Doug Bliss	Mettler-Toledo, Inc.
NTEP Administrator	Jim Truex	NCWM
NTEP Specialist	Darrell Flocken	NCWM
Public Sector Member	Dennis Beattie	Measurement Canada
Public Sector Member	Tom Buck	Ohio
Public Sector Member	Eric Morabito	New York
Public Sector Member	Edward Payne	Maryland
Public Sector Member	John Roach	California
Public Sector Member	Zacharias Tripoulas	Maryland
Public Sector Member	Ambler Thompson	NIST, Office of Weights and Measures
Private Sector Member	Mary Abens	Emerson Process Management
Private Sector Member	John Atwood	Tyson Foods
Private Sector Member	Gary Benjamin	NCR Corporation
Private Sector Member	Kevin Detert	Avery Weigh-Tronix
Private Sector Member	Andre Elle	Endress + Hauser Flowtec AG
Private Sector Member	Andrew Gell	Foss North America
Private Sector Member	Keith Harper	Gencor Industries, Inc.
Private Sector Member	Tony Herrin	Cardinal Scale Manufacturing Co.
Private Sector Member	Paul A. Lewis, Sr.	Rice Lake Weighing Systems, Inc.
Private Sector Member	Rick Lydon	SICK, Inc.
Private Sector Member	Dominic Meyer	KSi Conveyors, Inc.
Private Sector Member	Richard Miller	FMC Technologies Measurement Solutions, Inc.
Private Sector Member	Christopher (Adam) Oldham	Gilbarco, Inc.
Private Sector Member	Mike Roach	VeriFone
Private Sector Member	Robin Sax	CompuWeigh Corporation
Private Sector Member	David Vande Berg	Vande Berg Scales
Private Sector Member	John Wind	Bizerba USA, Inc.
Private Sector Member	Kraig Wooddell	Hobart



<b>NTEP Weighing Sector</b>		
<b>OFFICE</b>	<b>NAME</b>	<b>AFFILIATION</b>
Chair	Rob Upright	Vishay Transducers
NIST Technical Advisor	Rick Harshman	NIST, Office of Weights and Measures
NTEP Administrator	Jim Truex	NCWM
NTEP Specialist	Darrell Flocken	NCWM
Public Sector Member	L. Cary Ainsworth	USDA, GIPSA
Public Sector Member	Pascal Turgeon	Measurement Canada
Public Sector Member	Tina Butcher	NIST, Office of Weights and Measures
Public Sector Member	Kevin Chesnutwood	NIST, Office of Weights and Measures
Public Sector Member	Fran Elson-Houston	Ohio
Public Sector Member	Eric Morabito	New York
Public Sector Member	Edward Payne	Maryland
Public Sector Member	Marcus Harwitz	USDA, GIPSA, FGIS
Public Sector Member	Zacharias Tripoulas	Maryland
Public Sector Member	Juana Williams	NIST, Office of Weights and Measures
Private Sector Member	Steven Beitzel	Systems Associates, Inc.
Private Sector Member	Greg Bredahl	Thermo Fisher Scientific
Private Sector Member	Neil Copley	Thurman Scale Co.
Private Sector Member	Hayden Cornish	Schenck Process
Private Sector Member	Mitchell Eyles	Flintec, Inc.
Private Sector Member	Robert Feezor	Scales Consulting and Testing
Private Sector Member	Jon Heinlein	Transcell Technology, Inc.
Private Sector Member	Scott Henry	Motorola Solutions, Inc.
Private Sector Member	Sam Jalahej	Totalcomp, Inc.
Private Sector Member	Rafael Jimenez	Association of American Railroads Transportation Technology Center, Inc.
Private Sector Member	Stephen Langford	Cardinal Scale Manufacturing, Co.
Private Sector Member	Paul A. Lewis, Sr.	Rice Lake Weighing Systems, Inc.
Private Sector Member	L. Edward Luthy	Schenck Process Transport N.A.
Private Sector Member	Nigel Mills	Hobart Corporation
Private Sector Member	Jamie San Pedro	Coti Global Sensors
Private Sector Member	Wayne Pugh	OCS Checkweighers, Inc.
Private Sector Member	Louis Straub	Fairbanks Scales, Inc.
Private Sector Member	Russell Vires	Mettler-Toledo, LLC
Private Sector Member	Jerry Wang	A&D Engineering, Inc.
Private Sector Member	Walter Young	Emery Winslow Scale Company

<b>Western Weights and Measures Association (WWMA) <a href="http://www.westernwma.org">www.westernwma.org</a></b>						
<b>States</b>	Alaska Arizona California	Colorado Hawaii Idaho	Montana Nevada New Mexico	Oregon Utah Washington	Wyoming	
<b>Contact</b>	Kevin Merritt ISDA Bureau of Weights and Measures			(208) 332-8690 <a href="mailto:kevin.merritt@agri.idaho.gov">kevin.merritt@agri.idaho.gov</a>		
<b>Annual Meeting</b>	September 27 - October 1, 2015			Boise, Idaho		
<b>Central Weights and Measures Association (CWMA) <a href="http://www.cwma.net">www.cwma.net</a></b>						
<b>States</b>	Illinois Indiana Iowa	Kansas Michigan Minnesota	Missouri Nebraska North Dakota	Ohio South Dakota Wisconsin		
<b>Contact</b>	Sherry Turvey Kansas Department of Agriculture			(785) 862-2415 <a href="mailto:sherry.turvey@kda.ks.gov">sherry.turvey@kda.ks.gov</a>		
<b>Annual Meeting</b>	2016 (TBD)					
<b>Interim Meeting</b>	October 5 - 7, 2015			St. Charles, Missouri		
<b>Southern Weights and Measures Association (SWMA) <a href="http://www.swma.org">www.swma.org</a></b>						
<b>States</b>	Alabama Arkansas Delaware	District of Columbia Florida Georgia	Kentucky Louisiana Maryland	Mississippi North Carolina Oklahoma	South Carolina Tennessee Texas	US Virgin Islands Virginia West Virginia
<b>Contact</b>	Gene Robertson Mississippi Department of Agriculture and Commerce			(601) 359-1111 <a href="mailto:gene@mdac.state.ms.us">gene@mdac.state.ms.us</a>		
<b>Annual Meeting</b>	October 24 - 29, 2015			Biloxi, Mississippi		
<b>Northeastern Weights and Measures Association (NWMA) <a href="http://www.newma.us">www.newma.us</a></b>						
<b>States</b>	Connecticut Maine	Massachusetts New Hampshire	New Jersey New York	Puerto Rico Pennsylvania	Rhode Island Vermont	
<b>Contact</b>	James Cassidy City of Cambridge Weights and Measures Department			(617) 349-6133 <a href="mailto:jcassidy@cambridgema.gov">jcassidy@cambridgema.gov</a>		
<b>Annual Meeting</b>	2016 (TBD)					
<b>Interim Meeting</b>	October 13 - 15, 2015			Springfield, Massachusetts		

## National Institute of Standards and Technology

### Address to the National Conference on Weights and Measures to Commemorate Their 100<sup>th</sup> Meeting

Philadelphia, Pennsylvania

July 21, 2015

Carol Hockert, Chief,  
NIST, Office of Weights and Measures

My goal here today is to give you a brief history of weights and measures and the National Conference on Weights and Measures (NCWM), and to give you a feel for how and why National Institute of Standards and Technology (NIST) and NCWM are so closely intertwined.

**To set the stage:** In 1905, life expectancy was 47 years; 14 % of homes had bathtubs and 8 percent had telephones. There were 8000 cars in the United States and 144 miles of paved road. The speed limit in most cities was 10 mph. California had 1.4 million people; the 21<sup>st</sup> most populous state. Tallest building – the Eiffel Tower. Average U.S. wage – \$0.22 per hour. The American flag had 45 stars – missing Arizona, Oklahoma, New Mexico, Alaska, and Hawaii. Two of every 10 adults couldn't read or write. Only 6 % graduated from high school. Most births took place in the home (95 %)

**February 13, 1904:** A letter was sent by the National Bureau of Standards (NBS) director to governors of the states proposing a meeting of state sealers. This meeting occurred early in 1905. At the first meeting, Louis Fischer read a paper that gave a brief history of weights and measures in the United States. Of note, he mentioned the following historical actions.

- 1781 – In the Articles of Confederation, ratified by the colonies in 1781, there is found the authority for Congress to "fix the standard of weights and measures throughout the United States."
- 1788 – U.S. Constitution: It is the responsibility of the Congress to regulate both international and interstate commerce and to "fix the standards of weights and measures" in the United States.

Despite this, because Congress took no action, most of the states had adopted and secured their own standards. Studies of the marketplace found there was little uniformity within most states and still less between the states.

**May 19, 1828:** Congress adopts the troy pound for the standard of coinage. The brass troy pound weight obtained by the United States from London and kept at the Mint in Philadelphia, became the standard troy pound of the Mint of the United States. This became the *de facto* mass standard in the United States.

**Note:** When it was created, the Office of Weights and Measures was under the Treasury Department and prior to the creation of NIST in 1901, that agency defined the units and standards of measurement.

In 1832, large discrepancies were found to exist among the weights and measures in use at the different ports so...

Without waiting for authority from Congress, the Treasury Department, under the direction of Mr. Ferdinand Hassler, had the necessary weights and measures constructed for the customs service.

The avoirdupois pound adopted by Mr. Hassler as the standard for the Treasury Department was derived from the troy pound of the mint.

**June 14, 1836:** Congress finally directed sets of standards to be completed and delivered to the governor of each state. Most states adopted the standards once received, making the first attempt at uniformity. By 1850, states in the union, at that time, all had a complete set, and this continued as new states joined; the last set going to North Dakota in 1893. [How many states here today still have some of these original standards?]

**July 28, 1866:** Metric Act – This Act made it legal to employ the weights and measures of the metric system.

Interesting that only one day earlier: Congress authorized the delivery of metric standards to each state. The first state standards were made of brass.

**May 20, 1875:** Meter Convention – The United States was an original signatory to the Treaty of the Meter. When the reference standards of the United States arrived from France (meter and kilogram), they were inspected by the President himself. The U.S. standards resided with OWM from the time of their arrival here.

**April 5, 1893:** With the Mendenhall Order, the United States defines all customary weights and measures in metric units.

**1901:** Congress created the National Bureau of Standards.

Now, back to that first meeting in 1905. After Mr. Fischer gave this historical recount, the states provided reports on the status of weights and measures in their states. Here are some notable comments that were made:

- The Commonwealth of Massachusetts Deputy Sealer (1905) had this advice – States should create a separate office for weights and measures work, with a State sealer, who should be appointed by and be responsible to the governor. He noted that this system had been adopted and was in force in the State of Rhode Island and that it was working.
- He said that the office of sealers in the cities and towns should be placed in the civil-service and an examination required, so those hired are competent for the work. He also recommended that these officers be required to make an annual report of work performed to the State sealer.
- Professor Weld, State Superintendent of Weights and Measures in Iowa told an interesting story about the vault at the university in Iowa City that was the original capital of Iowa and included the old capital building where the standards were kept. He said that no one knew what the standards were for or even that they were there. There were rumors that the vault was haunted.
- He also said the laws of Iowa with reference to weights and measures were, like those of other States, exceedingly lax. In the rare occasion that standards were sent to Iowa City for inspection, the condition of the standards was pretty bad.
- And my favorite quote from the Professor of Mathematics from Iowa, “The time will presently come, I hope, when it will be necessary for me to lay down the office in my own State, in order to make way for someone whose other interests are not dominant, for someone with the necessary scientific training and endowed with the energy and executive ability essential to successful administration.” [When I read this, I think of Ivan Hankins.]
- It was reported that in Michigan, when the sealer of weights and measures in Grand Rapids resigned, the mayor decided that the work could be done by the police.
- Mr. John Richardson, of Virginia indicated that standards only needed to be tested and sealed every 10 years, which he called a “farce.”
- Mr. Isaac Brown of Pennsylvania suggested there should be annual meetings of the state sealers with the NBS and that a national law should be developed.

Moving ahead to the 1920 NCWM meeting:

- California had developed the prototype for today’s weight cart: an “automobile testing truck” with four tons of test weights on each.

- In Connecticut, gasoline pump inspections were conducted undercover. In 156 inspections, 80 were within tolerance, only 4 gave product away. Fifty were short, but not beyond 1 qt in 5 gal. Twenty dealers were convicted of violations of the weights and measures law.
- In Illinois, 432 gas pumps were inspected and all but two were condemned.
- New Hampshire published a brochure called “Practical Facts for the Purchasing Public” to market weights and measures.
- States were beginning to pass net weight laws.
- In Pennsylvania, inspectors were called “cheater chasers.”
- In South Dakota, their first year of inspections of devices showed a 90 % compliance rate! But, they could only test scales up to 30 lb, and they had two inspectors to cover the whole state.
- New York was testing vehicle weights with a portable vehicle scale.
- In New Jersey, the State Association believed they had the best set of weights and measures laws in the country, and they had the best paid staff.
- Nevada reported that after a visit by NBS in 1911, Nevada passed its first weights and measures law which went into effect in 1913.
- In Utah, they equipped two cars for weights and measures work with sleeping accommodations so the inspectors would not have to find a large town with a hotel.
- In Vermont, the owners of gas pumps were required to test them before the first sale each day with a sealed measure.
- Wisconsin reported using automobile trucks (1 ton) to cover their territory. Three trucks with two men in each.
- Maine passed a type approval law, requiring NBS approval on devices used in commerce.
- The sale of coal (large and small quantities) was a big deal. It’s how people heated their homes!

Let’s jump ahead again, to 1935 – the 25<sup>th</sup> Conference of NCWM. There hadn’t been a meeting since 1931 due to the great depression.

- Florida sent an Assistant State Chemist, who reported that while the State had no weights and measures division, there was a growing interest in the subject.
- Georgia sent a State Oil Chemist, who reported that some changes had been made in the weights and measures law at the last session of the legislature, but stated it was not being enforced, since no money had been appropriated for this purpose.
- In Maryland, it was reported that while the state had a general weights and measures law there was no State Department of Weights and Measures to enforce it and that few of the counties had sealers.
- In North Carolina, it was reported that under the approval-of-type law, some 3000 types of devices were submitted, and more than 1000 had failed of approval.
- In Virginia, it was reported that there were an increased number of jurisdictions now having weights and measures officials and that the state law was now similar to the model law adopted by the NCWM.

- In Wyoming, it was reported that some types of devices were regularly tested twice a year; however, others, such as coal scales and vehicle tanks, were tested only upon request, while still others, including most large capacity scales, were not tested at all on account of lack of personnel and equipment.
- In 1935, a tentative code for person weighers (scales used to weigh people) was modified and adopted. These were scales where you put a penny in the machine to get your weight. They didn't have bathroom scales back then. The Conference report shows that this topic was discussed at length over a several days.
- There was also extensive discussion on vehicle tank measurements.
- States were acquiring special equipment for large capacity scale testing.
- With the legalization of beer in 1933, legal capacities for beer barrels became an issue.
- Did you know there is on record a death during an NCWM meeting? During the night between the first and second day of this Conference in 1935, the Deputy sealer of Maine died, "Apparently he was walking in his sleep, he fell from a window, and it is now announced that he is dead." (I wonder if there's more to this story?)
- John Dickinson, Assistant Secretary of Commerce said, "We must find where the lines between the Federal Government and the State powers come. Those differences are not very likely to be raised if the Federal power and the State power work hand in hand and step by step in a cooperative manner."

In 1965, the NCWM celebrated their 50<sup>th</sup> meeting.

- Forty-three States and Territories (and D.C.) represented; over 650 attendees.
- Much has changed in 30 years, with the Conference now electing officers and a chairman. NBS has changed too. Moving to Gaithersburg, Maryland later that year (from Connecticut Avenue in D.C.).
- NBS Director Allen Austin attended a ribbon cutting ceremony to open exhibition. He reported on the CGPM meeting where they voted to redefine the second in terms of the invariant transition of the cesium atom.
- Austin talked about the development at NBS of a new weighing technique for very large weights that would save millions of dollars. It was called elastic weighing and used load cells as comparators. They were also beginning to use lasers for length measurements.
- OWM assisted the U.S. Postal Service (USPS) to develop maintenance test procedures for their scales. At this Conference, the USPS welcomed officials and inspectors to test postal scales.
- A model laboratory was on display.
- Tom Stabler introduced the new state standards program, the most recent delivery of standards and equipment to the states by NBS. Many of these standards are in use today, while others (Russell balance) have been retired after a long and productive career.
- There were strings attached to getting this set of standards. States needed to demonstrate that they had an adequate facility and full time personnel to run the lab. Huge change was taking place at this time. The state laboratory program was being launched. In the meantime, OWM was going to provide calibrations for the states until such time as their labs were ready. I love this quote from the Conference report:

"We in the Office of Weights and Measures eagerly anticipate the establishment of weights and measures laboratories in all States of the United States and the training of qualified personnel to perform a most essential service, necessary not only for weights and measures activities of the States, but also for educational institutions, industry, business, and for research and development effort."



And what a success this program has been. We have state labs that today are better than a number of the National Metrology Institutes around the world.

- The British had recently announced that they were switching to the metric system over the next ten years. Speculation on US changeover was discussed with agreement that the U.S. would follow suit.
- There was a presentation given on “Weighing in 1985”, 20 years down the road. In it, was the prediction that instrumentation and computers will be the backbone of industry, and that weighing devices will be more and more associated with data handling of process control equipment.
- It was noted in the 1965 annual report that the SMA provided over 5000 Third Man posters that were distributed for Weights and Measures Week. [Ken Tichota from Nebraska is sending one to OWM.]
- At this meeting they voted to change the time during which acceptance tolerances should be applied, reducing it from 90 to 30 days.
- Also at the 50th meeting, Ohio Chief of Weights and Measures gave a presentation on NCWM – a Program for the Future: He said that the organization of the National Conference will likely change, and talked about how change was good and even important. He also said the following: “However, regardless of the organization [of NCWM], it should have its roots in the National Bureau of Standards- that I do not expect to change.”

Jumping ahead again, to 1990:

- At this meeting, there was a re-enactment of the first meeting of the Conference. How many of you attended the meeting in 1990? And remember this re-enactment? Do you still have the red booklet?
- Most correspondence was still done via mail. Documents weren’t available online. There was discussion of staggering the publication of the handbooks to reduce costs.
- There were 318 delegates (123 guests) and 45 states, two territories present. At that time, 20 states had 100 % membership in NCWM.
- Gilles Vinet, Measurement Canada, attended the NCWM meeting in 1990 and determined that they were of value and that Canada would continue participation in the future.
- NTEP was still growing, expanding and being adopted by the states.
- Polyethylene sheeting was on the L&R Committee agenda, as was camera film, softwood lumber, moisture loss in pasta and pet food, and animal bedding. On S&T Committee, marking requirements for load cells made the list, along with minimum test weight load for railway truck scales, and tolerance tables in the scales code.
- The National Training Program was underway with 52 jurisdictions signing Letters of Agreement to participate. There was even discussion of a Certification program for NCWM.
- Ken Butcher, from Maryland, was one of the Vice-Chairmen nominees to NCWM. Dick Suiter, from Nebraska, was appointed to the S&T Committee.
- Incoming Chairman, N. David Smith, talked about preparing for the 21<sup>st</sup> century. It was a great speech and I look forward to hearing what he has to say this afternoon. He started by talking about the old conference reports, similar to what I am doing now, and he mentioned that some things never change, like the fact that the integrity of the S&T Committee had always been questioned. He suggested that the NCWM was undervalued and perhaps consciously avoided publicity. He also talked about what weights and measures would be like in 20 years, and how technology would change all aspects how we do our work. Finally, he challenged the NCWM to take stock of where they were and to plot a course for the future. He even created

a task force to shake things up at NCWM. He wanted NCWM to go to the membership rather than having the membership come to the NCWM.

In the 1990 Keynote address by Congressman Valentine from North Carolina, he talked about the challenges we face ahead of us and ended his speech with this: “Therefore, I hope that business and government, at all levels, can continue to work together to meet the challenge. Let's begin now to lay the groundwork so that we have something really big to celebrate in 2015 at the centennial meeting of the National Conference on Weights and Measures.”

So here we are 25 years later. Life expectancy is 78.8 years, average wage is \$10.50 per hour, there are 254 million cars on the road, and 2.65 million miles of paved roads. Many predictions made in previous years have come to pass. Many things have changed, and mostly for the better. A couple of items mentioned in David's speech in 1990 that I believe have changed for the better are that the integrity of the S&T Committee is no longer questioned at every meeting, and the NCWM is no longer avoiding publicity. Further, the NCWM has taken their services to the membership through its website, an example of which is having NTEP certificates available on mobile devices.

But some things have not changed, including the close relationship between the NCWM and NIST. As in all relationships, there have been growing pains and we've weathered some storms, but the commitment by both organizations to our common mission of uniformity and equity in the marketplace has allowed those times to fade in our memories.

I truly believe the NCWM has never been stronger or more effective than it is today, and it is positioned very well for the next 100 years. I will leave it to your chairman to talk about the specifics of where we are today as an organization, and what's in store for the future.

To paraphrase Louis Fischer at the first NCWM meeting: In conclusion, I know that in preparing such a short summary of so broad a topic, many things have been omitted, but I hope I have succeeded in giving you an outline of the growth and progress of our weights and measures system and the roles that NIST and the NCWM have played along the way.

Thank you very much for your attention. And now I'd like to present, on behalf of the NIST Office of Weights and Measures, this plaque to commemorate the 100<sup>th</sup> meeting of the National Conference on Weights and Measures.

This publication is available free of charge from: <https://doi.org/10.6028/NIST.SP.1210>

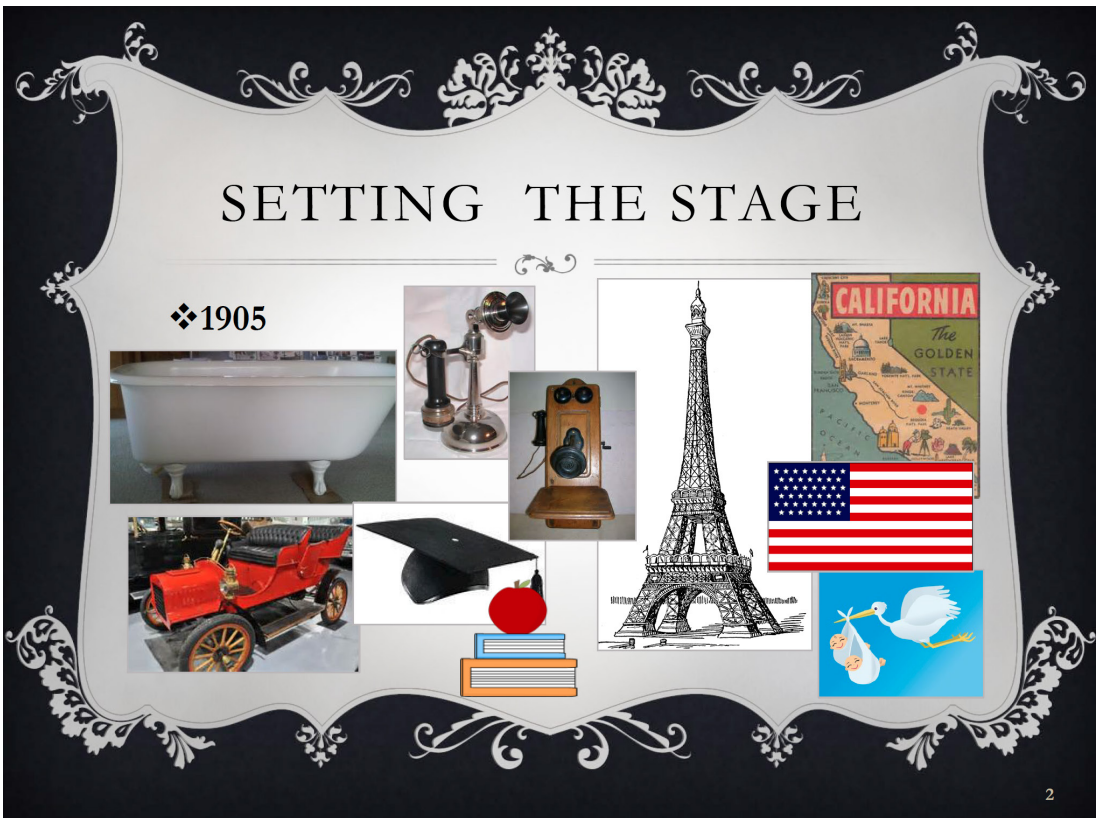
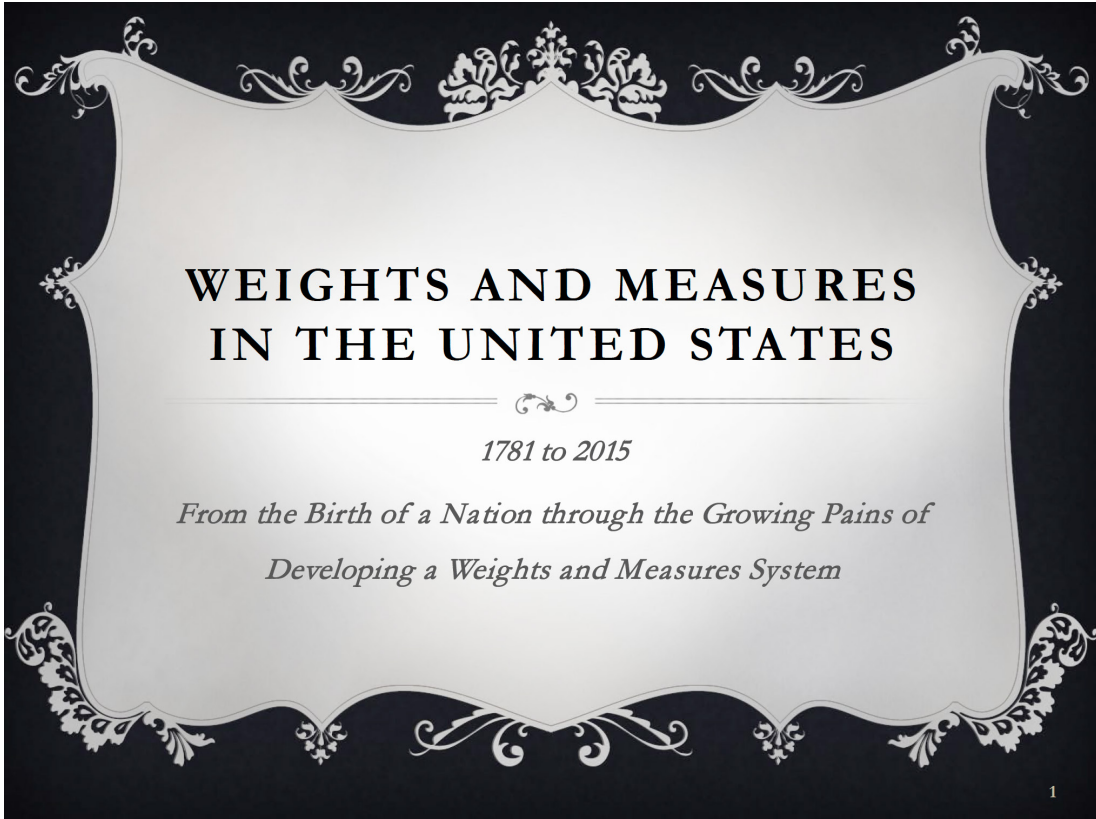

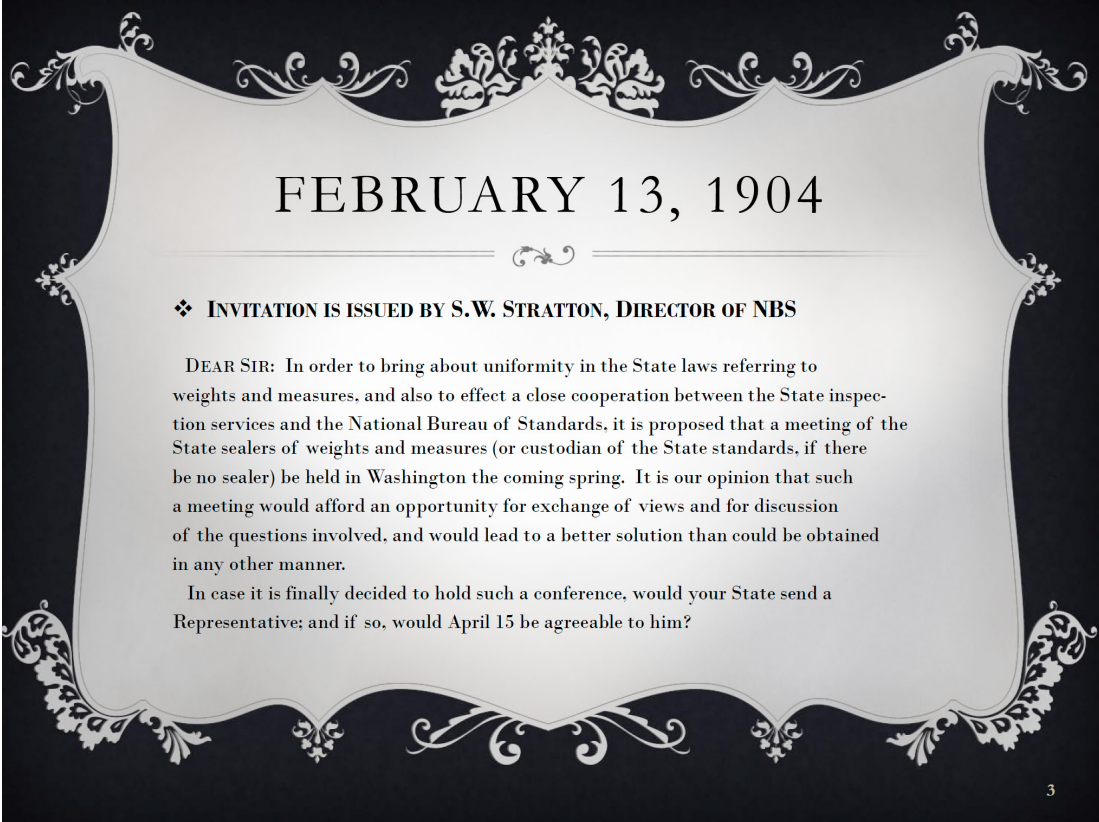

## FEBRUARY 13, 1904

❖ **INVITATION IS ISSUED BY S. W. STRATTON, DIRECTOR OF NBS**

DEAR SIR: In order to bring about uniformity in the State laws referring to weights and measures, and also to effect a close cooperation between the State inspection services and the National Bureau of Standards, it is proposed that a meeting of the State sealers of weights and measures (or custodian of the State standards, if there be no sealer) be held in Washington the coming spring. It is our opinion that such a meeting would afford an opportunity for exchange of views and for discussion of the questions involved, and would lead to a better solution than could be obtained in any other manner.

In case it is finally decided to hold such a conference, would your State send a Representative; and if so, would April 15 be agreeable to him?

3

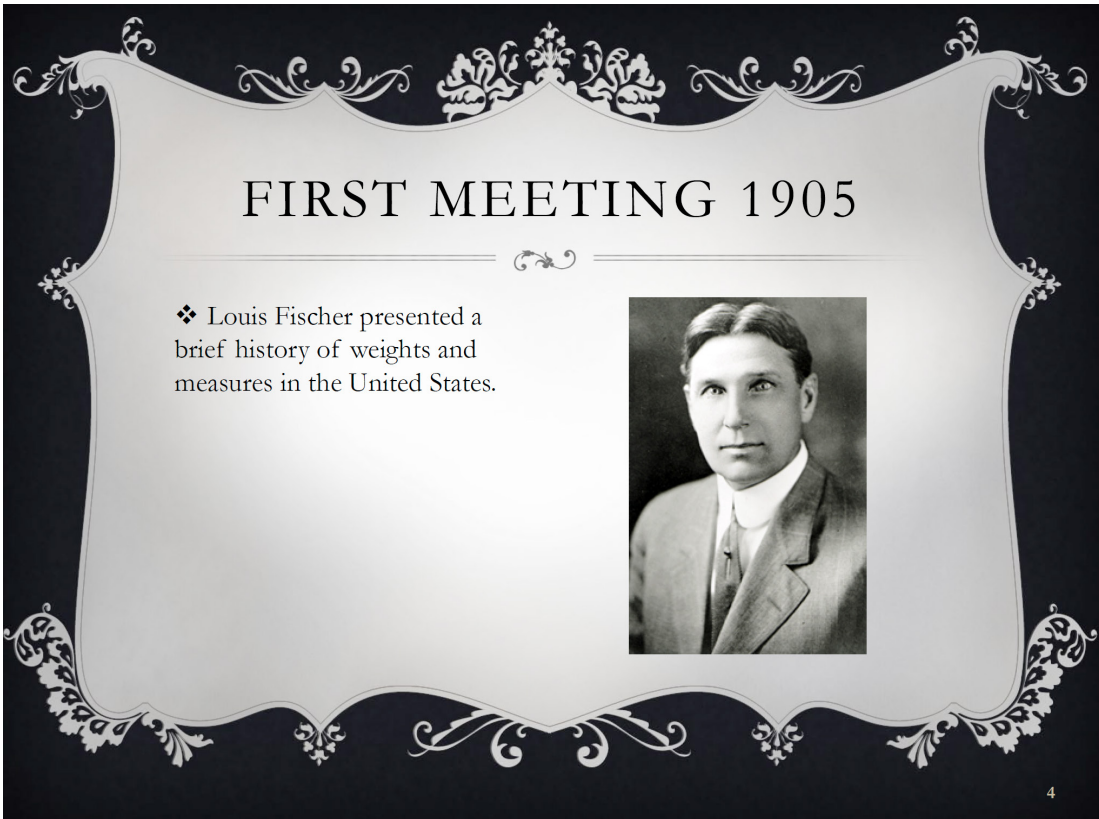

## FIRST MEETING 1905

❖ Louis Fischer presented a brief history of weights and measures in the United States.



4



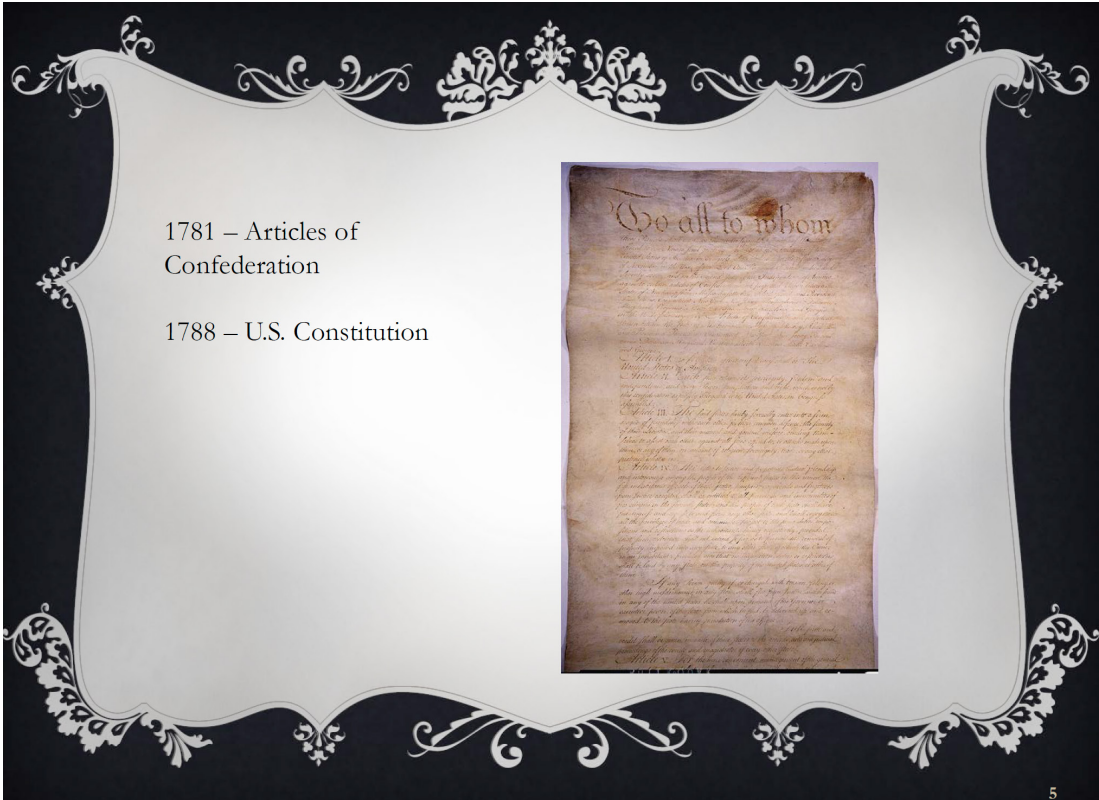





## 1850 STATE STANDARDS

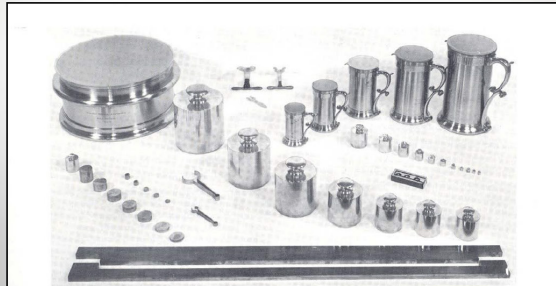

Standards of length, mass, and capacity furnished to the States under the joint resolution of Congress of June 14, 1836.

9

## 1866 METRIC STANDARDS

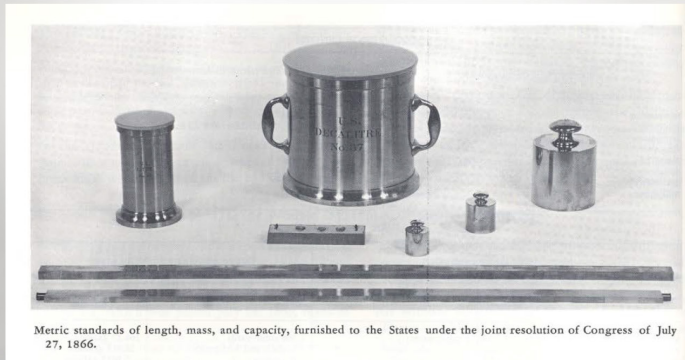

Metric standards of length, mass, and capacity, furnished to the States under the joint resolution of Congress of July 27, 1866.

10

## METER CONVENTION, 1875

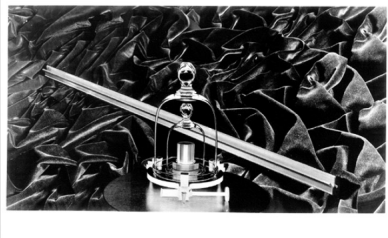

Meter bar and kilograms delivered from the BIPM

International Bureau of Weights and Measures

11

## MENDENHALL ORDER, 1893



12



## 1901- NBS

❖ National Bureau of Standards is formed.



13

## 1905-NCWM

The National Conference on Weights and Measures









This publication is available free of charge from: <https://doi.org/10.6028/NIST.SP.1210>





THIS PAGE INTENTIONALLY LEFT BLANK



## National Conference on Weights and Measures

### Chairman’s Address



Philadelphia, Pennsylvania

July 21, 2015

**Ronald G. Hayes**  
**Director, Missouri Department of Agriculture**  
**Weights, Measures and Consumer Protection Division**  
**Jefferson City, Missouri**

Good morning,

I am honored to have this opportunity to speak to you as Chairman of the 100<sup>th</sup> Annual Meeting of the National Conference on Weights and Measures (NCWM).

I have been fortunate to be part of NCWM for more than 30 years, but I have to say these last two years have been the most fulfilling of my career. It has been great to meet many of the local weights and measures jurisdictions throughout the country and share this knowledge with both my state and regional associations. Thank you for your hospitality and generously sharing your knowledge and ideas.

Three goals were selected for the Conference this year, so I thought I would start by sharing a progress report on those goals and finish with NCWM’s path to the future.

The first goal was to continue to enhance our training programs and the Professional Certification Program. The NCWM Professional Certification Program provides confidence that an individual has a strong understanding of U.S. weights and measures standards as adopted by NCWM and published in National Institute of Standards and Technology (NIST) Handbooks 44, *Specifications and Tolerances and Other Technical Requirements for Weighing and Measuring Devices*, 130, *Uniform Laws and Regulations in the Areas of Legal Metrology and Engine Fuel Quality*, and 133, *Checking the Net Contents of Packaged Goods*.” The Certification Program was a huge undertaking for a committee of volunteers, so the Board of Directors (BOD) took action to get the test exams on a faster pace. Mr. Ross Andersen, retired New York Weights and Measures Director, accepted the challenge to lead the development of these testing examinations. In the last quarter, three more exams have been posted to the NCWM website making a total of six modules. I would like to thank Ross, the Professional Development Committee (PDC) members, and the many volunteers who provided test questions. Next on PDC’s schedule is the liquefied petroleum gas (LPG) and price verification modules. Volunteers are needed.

It may be that I have simply been more aware of training opportunities, but it seems that training is at an all-time high. NIST’s grant and leadership role for training has provided many training opportunities throughout the country. Not only has NIST staff been at each of the regional meetings assisting in the technical committees, but they’ve also been there to provide additional training in specialized areas. The NIST “Train the Trainer” classes have strategically positioned qualified trainers evenly throughout the country. Many thanks to the Associate Membership Committee (AMC) who provided assistance with sharing expenses for trainers in many of the local training classes. I would also like to recognize Mr. Michael Cleary (retired from the state of California) for his willingness to travel and provide training to regional associations on the “Model-Field Training Program.”

The second goal was to build a closer relationship with other standards development organizations. An example of this would be our relationship with the Petroleum Equipment Institute (PEI). PEI has fourteen

recommended practices including design, installation, and service and repair in areas of underground fuel storage systems, above ground fuel systems, motor-fuel dispensers, diesel exhaust fluids, and compressed natural gas. PEI maintains relationships with federal, state, and local agencies, and other industry related groups allowing them to funnel regulatory interpretations and information on current technology and compliance issues. Twice a year, following the NCWM Interim and Annual Meetings, PEI reports a summary of the activities from these meetings in their “PEI Journal”. I urge you to visit their website [www.pei.org](http://www.pei.org) and review the latest “NCWM feature report” following each Interim and Annual Meeting.

Another standards development organization, ASTM International, is headquartered in the Philadelphia metro area. On Tuesday afternoon’s technical session during our 100<sup>th</sup> Annual meeting, the Conference will have a panel discussion on “Complementary Collaboration, A Case Study in Standards Development Cooperation.” The panel will include representatives from NCWM and ASTM International. Additionally, the Conference will have another panel of experts presenting the recent CRC Report No. 667 – Diesel Fuel Storage and Handling Guide. This presentation will be a condensed version of an ASTM workshop that was held at the D02 Committee on Petroleum Products, Liquid Fuels, and Lubricants meeting in June 2015. The NCWM representation was included in this workshop presenting the role of the weights and measures official in the area of fuel quality.

Recently, Ms. Kristy Moore, a NCWM member and a member of Fuels and Lubricants Subcommittee (FALS), was attending a Society of Automotive Engineers (SAE) meeting. In a committee meeting, there was discussion related to problems with new gasoline dispenser nozzles not fitting properly in new vehicles. Kristy informed the Committee that NCWM recently adopted a SAE standard practice for diesel dispenser nozzles to address mis-fueling of diesel powered vehicles. Members of this SAE Committee were pleased that the Conference had adopted the practice but encouraged NCWM to adopt the same practice for gasoline and flex-fuel vehicles.

These ongoing examples are just a few of the ways we collaborate with other standards writing organizations and demonstrate the impact NCWM can have.

ASTM International, American Petroleum Institute (API), SAE International, Petroleum Equipment Institute (PEI), American National Standards Institute (ANSI), National Fire and Protection Association (NFPA), UL, NCSL International, International Organization of Legal Metrology (OIML), and other standards writing organizations develop specialized standards and recommended practices; but they have no significance unless they are used in contract agreements or adopted by a law or regulation. For the common consumer, it is impractical to have a contractual agreement for each transaction. This is why it is necessary to have a law or regulation to protect both the buyer and seller.

The third goal is to work closer with federal agencies such as the Federal Trade Commission (FTC), Food and Drug Administration (FDA), U.S. Department of Agriculture (USDA), and others. Both the FALS and the Package and Labeling Subcommittees (PALS) have been providing guidance to FTC and FDA during the rulemaking process. Many of the NCWM recommendations are being recognized giving the work of the Conference acceptance in federal regulations.

A major milestone of the Conference was reached in 1984 when motor fuel users were complaining to weights and measures officials about fuel quality and vehicle performance. While a few officials argued weights and measures officials should not cross the line from quantity assurance programs to programs regulating quality, delegates were persuaded that the issue needed immediate attention. This new area of responsibility complements the device inspection part of weights and measures. This provides for a government that is more responsive and efficient. A few years later, the Conference created and adopted a Uniform Engine Fuels and Automotive Lubricants Regulation.



Traditional fuels are changing, and many new fuels and energy sources are emerging to meet the demand for environmental quality and to minimize climate change. In the last 30 years, mass flow meter technology has evolved to handle these new fuels as well as other commodities that are difficult to measure with traditional meter technology. Model specifications for these devices were needed and were developed.

As technology moves forward so does NCWM by forming various Subcommittees, Work Groups, Steering Committees, Sectors, and partnering with NIST and national experts. The structure of the Conference is working well. Since the establishment of our home base in Lincoln, Nebraska, the Conference is more responsive to the needs of society than ever before. I do not hesitate in saying, NCWM is the best it has ever been.

In our changing world for more energy, alternative energy, green energy, and zero emission vehicles, fuels are being developed to meet the requirements creating new challenges. We have some of the world’s best fuel experts as members of the NCWM Fuels and Lubricants Subcommittee.

Autonomous (driverless) vehicles are currently under development. In the very near future, we will see driverless taxi cabs. Weights and measures officials will again have new issues to address. Consumers will wonder if tipping is still expected, and I will wonder if the ride from the airport to the hotel will be as thrilling as the one I experienced this week.

Chair elect, Mr. Jerry Buendel, will discuss the vision of NCWM. I believe we should take another look at our voting process and consider voting more than once per year on issues. On another topic, we must continue to do more to move this country towards the use of the metric system.

Ms. Carol Hockert’s presentation on the history and evolution of the Conference shows how dynamic this organization is. The diversity of knowledge shared among our regulatory officials and industry partners makes this a great organization. Success happens when we are willing to work together!

Our special event will be at the National Constitution Center where we can explore the history and relevance of the Constitution, celebrate our freedom, and embrace our role in the story of “We the People.”

Congratulations NCWM on your 100<sup>th</sup> Annual Meeting!

THIS PAGE INTENTIONALLY LEFT BLANK.



## **National Conference on Weights and Measures**

### **Keynote Address**

**N. David Smith  
North Carolina**

Thank you for asking me to be your keynote speaker at the 100<sup>th</sup> Annual Meeting of the National Conference on Weights and Measures, which I will primarily refer to hereafter as simply, the Conference. As some of you may know, I have experience being the keynote speaker at centennial celebrations. In June 2004, I was the keynote speaker at the centennial banquet for ASTM Committee D02 on Petroleum Products, Liquid Fuels and Lubricants. My involvement as the keynote speaker at Committee D02 and here today is an interesting story. I know many of you have already considered I have a long history with both organizations, and it's probably extremely rare for one individual to be asked to give the keynote address at two centennial celebrations even though there is a close and long history with both organizations. Yes, that is correct but there is an even more interesting story behind the story.

When Committee D02 was planning its centennial celebration, the Planning Committee sought to invite a speaker of note and one with a connection to the petroleum industry. Their first choice was former President George H. W. Bush. An invitation letter was extended, and a regrets reply was promptly received indicating that the timing of the DO2 celebration coincided with the Bush family's traditional summer vacation in Maine. The Planning Committee revised their criteria to concentrate on availability. I became the available keynote speaker.

I'm told the Conference Planning Committee also wanted a national speaker of note. It was reported to me; they discussed inviting former Secretary of State Hillary Clinton until they learned of her \$350,000 speaking fee. The Planning Committee revised their criteria to concentrate on cheap. Apparently someone suggested they could get N. David for airfare and hotel expenses — in other words, somewhat cheap.

So, my reputation as a keynote speaker is now intertwined with available and cheap. If there are any aspiring keynote speakers in the audience, you may want to be known as the available and cheap choice.

While planning my comments for this celebration, I reviewed my presentation to Committee D02. I was able to use some of the same material; further strengthening my cheap reputation. A quote from Henry Ford, "Coming together is a beginning; keeping together is progress; working together is success." Not many organizations involving government officials and private industry members can say they have been meeting together for 100 years. The quote from Henry Ford is a perfect description of the National Conference on Weights and Measures.

It is customary to start a presentation by acknowledging special guests and dignitaries in the audience. I have sat through enough political speeches to know that many speakers take up too much time introducing the notables in the audience, and then they leave out a few. Any good will they had hoped to generate was lost by an unintended oversight. I will limit myself to two individuals and two very special groups.

The special guests I want to acknowledge are Ann Turner and Otto Warnlof. If you were associated with the Conference during the 1980s and 1990s, you came to rely on Ann for everything. Ann was the gatekeeper, solver of problems, and confidant when things did not go according to plan. Meetings did not get done without Ann's guiding touch. Ann gave everyone confidence that every meeting would be flawless. Otto was Mr. Specifications and Tolerances for over 20 years. He was the technical adviser to the S&T Committee and nothing was added or taken

from NIST Handbook-44 without his approval. In addition, Otto was part of the greatest generation as chronicled by Tom Brokaw. Otto was a B-17 co-pilot in the U.S. Army Air Corp, the Mighty Eighth. He will not tell me how many missions he flew in World War II. Please join me in thanking Ann and Otto for their dedication to the Conference.

Events like this just do not come together without planning. Your 100<sup>th</sup> Annual Meeting Planning Committee members deserve your appreciation for their hard work and dedication. It is not an easy task to plan a special event. Please join me in showing our appreciation.

The last special guest I want to recognize is — each of you. It is the dedication of you, the individual member, which makes the Conference so successful. Please give yourself a hand.

Your speaker is a country boy from rural North Carolina. I grew up on a small farm in the eastern part of the state. Until I started working for the North Carolina Department of Agriculture, the biggest trip I had experienced was to Myrtle Beach, South Carolina. My involvement with the Conference changed everything. I have visited almost every state, made friends with many great people, slept and ate in some very fancy hotels, and had the opportunity to make a positive contribution to the business of weights and measures.

While pondering what I wanted to incorporate in my presentation, I decided there was no need for me to review the beginning history of the Conference. After all, we have Charlie Carroll and Joe Silvestro in attendance and they can probably give a first person account of the initial meeting between Dr. Stratton and the nine state representatives. I decided to concentrate on the time I first attended the Conference moving forward to more recent times. For those of you who have been involved with the Conference for less than fifteen years and especially for less than eight years, you may not know that much has changed. The Conference is a completely different organization today versus my initial exposure in 1978 at the 63<sup>rd</sup> Conference.

The 63<sup>rd</sup> Conference was held at the Shoreham-Americana Hotel in Washington, DC. A single room was about \$25 and a double in the \$30 range. Registration was \$50. I need to take a few minutes to describe the hotel. The hotel was built in 1930. In its heyday it was a major social and political powerhouse. According to a Forbes article I found, the hotel was home to many well-known senators and congressmen. It was common knowledge that former Missouri Senator Stuart Symington frequently hosted President Truman in his room for all-night poker sessions. In 1933 to accommodate President Roosevelt's wheelchair for his first inaugural ball, the hotel built a special ramp and elevator. The Beatles rented the entire seventh floor for their February 1964 Washington concert, which was their first concert in the United States. It was reported the Beatles had to schedule several concerts to cover their travel expenses because Ed Sullivan only paid them \$8,500 for three television appearances. Here is the story I particularly like. To avoid wartime alcohol rationing, the hotel purchased all the stocks of a Scottish distillery.

The hotel featured one of the swankiest nightclubs in Washington, the Blue Room. The Blue Room was where Liza Minelli gave her first public performance. It is where presidents took their wives for fancy night on the town dates. The hotel is where the political satirist and comedian, Mark Russell, skewered Democrats, Republicans, and Independents alike from the Marquee Room.

According to the same Forbes article, the Blue Room closed in 1975 and the hotel fell into disrepair. My exposure to the Conference and the hotel was in 1978. When the taxi pulled up to the hotel, it was easy to see the hotel was a magnificent place. Its architecture was grand, big, and bold.

I was excited because I had never stayed in such a grand hotel. The lobby was magnificent, but as you looked around, you got the sense the hotel had seen better days. You could look at the furniture and see the wear and other signs of aging and neglect. Still, I was excited and eager to see my room. Imagine my surprise when I unlocked the door only to find the ceiling in the bathroom had collapsed to the floor. That was my introduction to the National Conference on Weights and Measures.

I must point out my first Conference revealed the depth and quality of the leaders of this organization. As an example, the Resolutions Committee honored the Chairman of the previous Conference, Earl Prideaux of Colorado. Like Otto, Earl was a member of our greatest generation. If you have ever seen a picture of General George Patton relieving

himself in the Rhine River in Germany, you have also seen Earl. He is one of the officers standing alongside General Patton. At that point, I knew strong leadership would be the hallmark of this organization.

I did not attend the Conference the following year when it met in Portland, Oregon. I returned in 1980 when the Conference again staged its Annual Meeting, where else but the Shoreham. I don't recall much from that Annual Meeting; at least I don't recall any issues with my room. To be honest, the hotel is now owned by the Omni Corporation, and I understand they have pumped millions of dollars into the hotel to return it to a grand state.

I want to return to my history lesson for the most recent members of the Conference. How is the Conference different today versus my initial exposure? For one thing, the hotels have improved greatly. Let's start with the Interim Meeting. During my early years in the Conference, the Interim Meeting was always held at the National Bureau of Standards in Gaithersburg, Maryland. We just called it the Bureau for short. The timing of the meeting has not changed, mid to late January, but in that timeframe, there is a big difference in temperatures between Gaithersburg and San Diego, California, the location of the 2016 Interim Meeting. We could always expect to see snow piled on the street corners; often times it would be snowing or at the least we could expect a cold, miserable rain.

Those attending the Interim Meeting were housed in a hotel near the Bureau. Sometimes it would be a nice hotel; other times there were issues. I recall being located in one of those smaller hotels that cater to the casual family traveler as opposed to business clientele. The hotel was not prepared for over 100 people to all take showers at 6:00 in the morning. After the first morning of cold showers, we all agreed to take showers in shifts beginning at 4:00 a.m. and to give the water heater enough time to recover between shifts. We never went back to that place.

At that time the Bureau was located in a somewhat remote location. It was surrounded by farms that were rapidly transitioning to housing developments and commercial uses. It was a journey just to get to the Bureau. For those arriving by air, you landed at Washington National Airport and carried your luggage across the street to the Metro rail stop. Note I said you carried your luggage because that was before someone came up with the brilliant idea to put wheels on luggage. For those of us not savvy to the ways of commuter trains, it was always an adventure to figure out how to buy a ticket to the correct stop. Once the ticket purchase was accomplished, you caught the yellow line to its intersection with the red line. You skipped over to the red line and hoped that you were on your way to Shady Grove (Gaithersburg), Maryland, the end of the line and the getting off place for the Bureau. Maybe you had made arrangements for someone to pick you up and take you to the hotel. Maybe you could find a waiting taxi. Maybe a fellow Conference member was on the same train and you would have a companion while you figured out how to get to the hotel. I want to remind everyone this was long before anyone had a cell phone. Sure, I could use a pay phone (they had those back then) and enter my state issued calling card number which consisted of about 32 numbers and later explain to our accounting department why it was necessary to call a taxi while in Shady Grove, Maryland.

Eventually you would arrive at the hotel where you would be greeted by your fellow Interim Meeting colleagues. The entire Interim Meeting experience was something like going to camp in the middle of winter. Each morning at 7:00 the Bureau would send a bus to pick everyone up and deposit them near the front door of the Bureau. By bus, I mean a green school bus type vehicle; not unlike the ones used by prison departments to transport inmates. That bus was important because it was going to be your transportation back to the hotel after 5:00 p.m. Once you stepped foot inside the lobby of the Bureau, you were officially Bureau property. You ate breakfast and lunch in the Bureau's cafeteria, lived by their rules, and checked the time on the many clocks that were strategically positioned throughout the building. I always thought it odd that even at the National Bureau of Standards not all the clocks showed the same time. Regarding the cafeteria, it was industrial with little regard to food presentation, and they served the worse coffee ever offered to mankind.

It was a fascinating time for me. Here I was at the National Bureau of Standards where the lobby was filled with plaques and citations honoring all the scientists that had worked at the Bureau and all the scientific discoveries coming from the work done there. Just reading the plaques was humbling because you knew you were in the presence of great scientific and engineering thinking and cutting edge experimentation. There I stood surrounded by scientific greatness and my main concern was getting folks to understand that 16 ounces equaled one pound.

Each Committee was assigned a room, which resembled a large interrogation room in a big city police department. The Committee members sat at the center table surrounded by industry representatives sitting in straight back chairs lining the walls. Each Committee had an adviser from the Office of Weights and Measures and each one was dedicated to his or her craft. We plowed through our agendas with our advisers taking careful notes because they were often the ones who put the final product on paper. So, when the bus picked us up at 5:00 p.m. our advisers remained at the Bureau to bang out what had been decided that day. Again, recall, this was in the days before modern word processors. You make a mistake, you start over.

One day during the week, we would have lunch with the Director of the Bureau, who for many years was Dr. Earnest Ambler. He was a likeable fellow who would always tell us the Bureau was short on funding, but he was generously allocating funds to the Office of Weights and Measures because he so appreciated our dedication and loyalty to weights and measures principles. Over lunch he invited our comments and questions. I think our relationship started to change in the mid-1980s when Joe Swanson of Alaska said “Ernie, you are just not getting it done for weights and measures.” We just didn’t know how much and dramatically things were about to change.

After lunch on Friday, the Bureau would release us from its hold and we would reverse the Metro trip from Shady Grove to the stop at Washington National Airport. Looking back on those days, while they were mind numbing because you were essentially held hostage at the Bureau surrounded by bone chilling temperatures, it was a time deep friendships were formed with colleagues from other states, jurisdictions, and the private sector. Standing in the Bureau’s lobby waiting for the bus and taking the bus to and from the hotel allowed you time to really get to know your fellow weights and measures colleagues. We had conversations about the value of weights and measures, how to make our laws and regulations better, and how to be more effective and efficient in our programs. Maybe the Bureau had a plan after all.

The annual meetings were much different back then. They would start on Sunday and end Friday afternoon. The program was packed with scientific and scholarly presentations on subjects relating to weights and measures and measurement standards. The state metrologists met during the Conference, and they had a full weeklong agenda of technical training. I also want to point out that the Standing Committee meetings were taking place while the formal presentations were being made, and the Standing Committee meetings were all scheduled at the same time. It was easy to miss an important discussion because you were in the wrong place at the wrong time. From the registration list of the 1978 Annual Meeting, I count 170 state and local officials, 179 industry representatives, 54 U.S. government officials, and 28 representatives of foreign countries as well as retired individuals and representatives of non-profit organizations. That is a total of 431 registered participants. Don Onwiler tells me his research shows, during the 1960s and 1970s, it was not uncommon for the attendance to average 500. Contrast that to the 2010 Annual Meeting with 235 participants and even this one with around 275 registered participants. Except for addresses by the leadership of the Conference, little time is now spent on anything but presenting the business of the Conference. I guess it’s all about being efficient with time and money. Looking at the agenda for my first Conference, I count 15 presentations outside the ones given by the Conference leadership. For the meeting this week, I count two.

I don’t miss those scientific presentations because they seem so dated looking back now. For example, at my first Conference there was a presentation on electromagnetic interference and what must be done to protect all those devices that would soon be driven by microprocessors. The speaker focused on CB radios and the problems they were causing. He noted that in 1975 truck manufacturers started installing electronically-controlled anti-skid braking systems. Eighteen thousand trucks had to be recalled due to break interference by CB or mobile radios located in the truck or in a passing truck. I can’t imagine he had a clue that one day virtually all of us would walk around with a small, powerful device that would allow us to communicate in various forms with anyone in the world regardless of the locations of the users. In fact, I have some interesting information regarding cell phone usage. The population of the United States is about 319 million, and it is estimated there are 328 million cell phones in use. In March 2013, the United Nations estimated that 6 billion of the 7 billion inhabitants on earth had cell phones. That is almost 90 % of the earth’s inhabitants. The United Nations went on to say there are more people with cell phones (6 billion) than have access to working toilets (4.5 billion). This is just one example of how quickly events and circumstances change and often they have a tremendous impact on how we conduct our business.

I was handed the Chairman's gavel in July 1990 at the J. W. Marriott in Washington, D.C. Looking back we may have been near the apex of our relationship between the National Institute of Standards and Technology, yes the name changed in 1988, and the National Conference on Weights and Measures. Storm clouds were on the horizon, but I'm not sure any of us saw what was coming and how dramatically it would change that relationship.

In my incoming Chairman's remarks to the Conference, I used my son, Eric, as the poster child for the future of weights and measures. Eric was 10-years old at the time. Eric is here today, but in a completely different role than I talked about in July 1990. It is hard to believe it has been 25 years. I foresaw Eric as the weights and measure inspector of the future where he would need to have a scientific or engineering background to work through the complexities of weights and measures enforcement; where auditing device and packaging performance was more important than actual inspections because field inspections were rare due to devices being self-calibrating. I foresaw Eric as a weights and measures device manufacturer that seamlessly put his devices in trade throughout the world because of uniform international standards. I foresaw Eric as a packager that openly understood that net contents records would be shared with regulatory officials and any shortages would be resolved quickly and targeted to the affected markets. I foresaw Eric as a consumer more concerned about the cost of health care, the environment, and food and product safety than the importance of weights and measures. Lastly, I foresaw Eric, the taxpayer, whose priorities reflected those of Eric the consumer. I posed the question — in the year 2000 would any weights and measures program be a general fund obligation or will the programs be solely supported by inspection and registration fees? There is still some general fund support but many of us now exist on fees and other non-general fund receipts. Collecting money, in addition to inspecting devices and packages, is now part of the job description.

So what has Eric done in the past 25 years? He has fulfilled many of my predictions; just not as a weights and measures inspector. He has a degree in chemical engineering and works for a major pharmaceutical company. I will point out his choice of degree was influenced by Chip Kloos, a former industry representative with Hunt-Wesson Foods, who for many years was a major contributor to the Laws and Regulations Committee. Eric works from home collaborating with his team members located in several countries. He devotes time to auditing records and solving problems remotely rather than being at a production facility. Of course, he is concerned about the cost of health care because he is part of that industry — his income depends on it. He takes weights and measures for granted because he rarely hears any news about weights and measures scandals or the cost to consumers, taxpayers, or the regulated community.

I concluded my year as Chairman when we met at the Four Seasons hotel in Philadelphia. It seems fitting we are back in Philadelphia today for the 100<sup>th</sup> Annual Meeting celebration. Much of my professional life is centered around the City of Philadelphia. I attended my first ASTM meeting at the former ASTM headquarters on Race Street and the Philadelphia airport is by far my most visited airport. I recall my stay at the Four Seasons where Pam, Eric, and I were assigned the presidential suite. Eric had his own room. It was at the Four Seasons where Eric discovered room service. He declared there was nothing better than having food brought to your room and being able to watch TV while eating. I discovered that room service for every meal is expensive. Another interesting memory of that meeting was what happened to my shoes. As a perk, if you hung your shoes on the door at night, the hotel would polish them and return your shoes early the next morning. At the same time, we were at the hotel, the Kennedy family was having a wedding there. I suspect someone connected the presidential suite and the Kennedy family and decided to make off with a pair of what they thought to be Kennedy shoes. I have often wondered how many times my loafers have been passed off as authentic Kennedy memorabilia.

As I said at the beginning, this presentation will concentrate on more recent times rather than the entire history of the Conference. In the past 40 years, this organization has been blessed with great leadership. I don't intend to name all the chairmen and leaders, but I would like to highlight a few.

- Syd Andrews from Florida was a leader in the Conference and in ASTM. I learned a great deal from Syd and I owe him my gratitude. He was a mentor and dear friend.
- Jim Lyles of Virginia was the consummate Southern gentleman who had the ability to tell someone they were wrong in their beliefs and receive a thank you for pointing that out.

- Ken Simila of Oregon, who was noted for not holding back on his comments, once famously declared the Oregon legislature had repealed the law of gravity.
- George Mattimoe of Hawaii was a character that was enhanced by his traditional Hawaiian attire of white, baggy pants and floral shirts or as some of us were fond of saying — the only person permitted to attend a formal session of the Conference while dressed in pajamas.
- Darrell Guensler and Barbara Bloch of California brought steady guidance and leadership to the Conference during times of change. I think California’s governance system for weights and measures gave them unique leadership skills. By the way, I think California has contributed more Conference Chairmen, seven, than any other state.
- Dr. Charles Green and Fred Gerk of New Mexico brought insightful thinking and common sense. They, along with their wives, also introduced us to Southwestern cuisine as they would prod us to try different and sometimes very spicy dishes, which they fixed and dished up themselves often from their RVs.
- Tom Geiler of Barnstable, Massachusetts, pushed the Conference into making hard, difficult decisions. He is probably the only person to transport a three-gallon pot of clam chowder across the country only to prove that New England clam chowder is better than some western state fish stew. Can you imagine getting that pot through airport security today?
- Wes Diggs of Virginia served the Conference twice and the last time under difficult circumstances. We owe Wes and the State of Virginia for the extra time devoted to the Conference.
- Randy Jennings of Tennessee continues to be a leader in the Conference and in ASTM. He brings tremendous creditability to any task he undertakes.
- Steve Benjamin of North Carolina is my colleague in my interface with the Conference and the Southern Weights and Measures Association, and in our ongoing state budget deliberations. Steve and I work together to support and defend his budget before State legislative committees and to avoid being the second State on record to repeal the law of gravity.
- Jim Truex of Ohio brought great technical skills to the Conference, and he continues in that role today where he is now on the Conference payroll.
- Ross Anderson of New York started his involvement with the Conference as a metrologist and worked his way up to chairman. Like Jim, Ross contributed outstanding technical skills that continue to pay dividends today because he added to the Conference’s technical reputation.
- Don Onwiler of Nebraska has perhaps had the greatest and most lasting impact of any Chairman. Not only did he serve the Conference in a volunteer role, he now serves as the Executive Director and from my observation, he is doing a fine job.
- Too numerous to mention are the private sector members who contributed to the success of the Conference. Without their input and guidance, our decisions could not stand the test of time and regulatory scrutiny.
- I want to acknowledge the considerable contributions from the Office of Weights and Measures. Harold Wollin was the recognized leader when I first joined the Conference. Al Tholen was a saint, but we drove him to have a heart attack. Dr. Carol Brickenkamp had the patience of Job and we tested that patience at every opportunity. Then came Henry Oppermann whom we respected on many levels for his metrology expertise and professionalism. The most recent leader is Carol Hockert, whom has the respect of everyone and as Carol told me Sunday night, she respects the Conference.



What have we accomplished in the past 100 years? I suppose I could ask everyone in this room for a response and receive many different answers. There would be some overlap, but not everyone would agree on the top eight accomplishments. Why eight? That is just the number I settled on. To get the conversation started, here are my top eight. We can debate them in the hallways and watering holes over the next couple of days. I look forward to those conversations.

- In the face of budget cutbacks, industry consolidation and distain for government programs, the Conference has remained a significant force for over 100 years. Through good times and bad, “volunteers” have continued to show up at meetings, read and comment on reports, and make a strong case that fairness in the marketplace does matter. The Conference is a national forum for those interested in expressing an opinion about anything involving weights and measures. It works, it is open to anyone and is conducted in complete transparency.
- NIST Handbook 44, *Specifications and Tolerance and Other Technical Requirements for Weighing and Measuring Devices*, continues to be the standard for weights and measures devices. It is a living document that does not go through the federal review process; yet it is used by federal agencies because it is recognized by everyone as the bible for weighing and measuring devices.
- NIST Handbook 133, *Checking the Net Contents of Packaged Goods*, was controversial from the beginning. No one thought it had a chance of being accepted by anyone. Here we are today, and it is relied on and accepted by virtually every entity involved in the packaging industry.
- The long standing participation and support of the private sector. Without the support and participation of the scale manufacturers, gas pump manufacturers, the consumer products industry, the packagers, and a host of other business sectors, the Conference would be a one sided affair lacking the necessary balance to be a legitimate organization. It must be noted that many of the private sector members have tenure in the Conference rivaling any weights and measures official. That longevity is simply remarkable in this day and time.
- For a long time, the importance of having a recognized standard for engine fuels was not on the radar of many state agencies. It was not until the Conference got seriously involved in the conversation that the importance gained national attention. Prior to the Conference’s involvement, the debate was primarily between the petroleum producers and the automobile manufacturers. The Conference’s involvement brought the discussion to the actual user — the person who buys the product. The interest of the Conference has also aided ASTM because more states have gotten involved in the ASTM standard development process. As an aside, I think the purchase of engine fuel is one of the most unique purchases in the retail market. A purchaser puts the product in his or her vehicle before paying. How do you give it back if there is a dispute about the quantity or quality of what has been dispensed? It is purchased sight unseen without any way to value what has been dispensed. It is done on faith and trust in the system.
- NTEP started as a concept to ensure production meets type, especially with respect to load cells. Today it is a testament to our earlier desire that we institute a national, uniform system for approving devices so manufacturers do not have to gain approval from every state. NTEP continues to grow with wide acceptance of its Verified Conformity Assessment Program.
- The strong leadership of the Conference’s executive staff and Board of Directors. In recent years, they have taken bold action in the face of long odds. I’m not surprised. Those individuals have faced long odds at home with budget decisions and program direction. They simply used their experiences to make decisions that benefitted the Conference for the long term. I commend all of them for being bold and decisive.
- On the display piece in the room are the approval seals of 57 states, jurisdictions and territories. You also have a copy rolled up in that cardboard tube you received at check-in. The piece represents 57 sovereign units of our national government. Yet, all of them are working for a common goal — That Equity May

Prevail. I find it remarkable in this day and time all of us are striving to accomplish a common, national goal without being housed under a federal agency. We should be proud of what we have accomplished and the way we conduct our business.

That sums it up. We have traveled a long journey. We have been led by many different individuals, but we have never lost sight of the goal line. Fairness, transparency, and equity do matter in our daily lives. Look back on the first 100 meetings with pride and look forward to the next 100 meetings with anticipation based on our great weights and measures foundation founded on the principles of strong leadership and a belief that equity in the marketplace does matter.

For our future leaders, I urge you to look for new ways to accomplish the routine. Like your Conference mentors, be bold in your thinking, be confident in your decisions, and know that technology and world events will change overnight to challenge your thinking and decisions. Yet, as John Adams began his report to Congress in 1821, “Weights and measures may be ranked among the necessities of life to every individual of human society.” We can’t let the importance of weights and measures programs pass silently into the night. Work hard, be decisive, engage a diversity of supporters, be transparent in your deliberations, look for new, more efficient ways to accomplish the routine, and continue to be inclusive in your membership. I am confident the National Conference on Weights and Measures will continue to be a strong force for the next 100 years.

Thank you for asking me to share my thoughts on the anniversary of our 100<sup>th</sup> meeting.

# **National Conference on Weights and Measures**

## **Chairman Elect’s Address**

**Philadelphia, Pennsylvania**

**July 23, 2015**

**Jerry Buendel  
State of Washington**

It is indeed an honor to be entrusted with the role of Chairman of the National Conference on Weights and Measures (NCWM). In the past year, I have had the pleasure of traveling to the regional meetings to meet officials and industry members and come to recognize the incredible talent we have in this organization.

In watching our Chairman, Ron Hayes, and the Chairmen before him, I’ve learned this job requires uncommon dedication and tests one’s skills in ways that our present jobs and past experiences do not prepare us for. Thank you Ron for setting an excellent example and for your work in making this celebration of our 100<sup>th</sup> meeting a rousing success.

I pledge to you that I will do my best to lead this organization and more importantly to lead by making the most of the willing and talented individuals in this organization.

I certainly hope the Nominating Committee didn’t offer my name using the same criteria as our keynote speaker – “cheap and available.”

Ms. Carol Hockert spoke so eloquently of our past and both her verbal presentation and the wonderful photos painted a picture of where we’ve been, the many challenges our predecessors dealt with, and the high standards they set – except for the death of the Deputy Sealer of Maine who died in 1935. Steve Giguere – these aren’t footsteps you want to follow. I only hope that I can in some measure contribute to their body of work and not be mentioned in the body of work of our friends Sven, Ole and Lena. Carol – thank you for that visit with the ghosts of the past and for entertaining us with the misadventures of those characters.

As is our practice I need to speak of the future and I think it is appropriate at this 100<sup>th</sup> meeting to talk about vision and of goals for the next year. I have chosen a theme of “NCWM – Strengthening a Progressive Organization.”

I’d like to spend the next few moments talking about our future as an organization, a vision of coping with change and some goals for the next year.

I think we should spend some time in thoughtful reflection and try to imagine what the next 100 years will bring and what you, as an individual, will do to meet those challenges in writing the history of this organization.

First let me speak of a vision around change. I was inspired last night by the courage and conviction of our founding fathers that was so well depicted at the Constitution Center. The intense debates and collaboration must have been a sight to behold. These were passionate, highly intelligent people focused on a common goal and committed to creating a system of government that would allow its citizens to live and prosper in ways that mankind had never conceived of or operated under before. That government, our wonderful democratic system, has proven to be lasting, durable, and amenable to gradual yet profound change to meet the needs of a growing and evolving society.

While moving through the displays that walked us through our rich history, I came to see some similarities with our organization, NCWM. I recognized the work our predecessors did in structuring our Committees, taking on things like motor fuel quality, making adjustments to our operations, establishing NCWM as a nonprofit corporation, and operating the National Type Evaluation Program. I also came to realize a call for change as our members spoke sometimes in the hearings and sometimes in the halls of the need to explore ways to conduct our business so that we can quickly and responsibly respond to a rapidly changing marketplace and the needs of industry.

The strength of NCWM is its ability to respond to marketplace regulatory needs with the best thinking available. We regularly do the “hard” things well. I want to be proactive in responding to that call. I will begin by charging your Board of Directors (Board) to look at the way we operate, develop standards and interact with the many stakeholders and identify areas for improvement and recommendations for changes. I will expect them to be bold yet thoughtful and mindful of our fundamental values in their work.

Next, I’ll talk about one of two goals for the coming year.

The inspiration for my first goal came on Tuesday while listening to our keynote speaker, Mr. N. David Smith. He outlined the eight strengths and achievements of NCWM. He reminded us that equity does matter and he spoke of building and maintaining a progressive and vibrant organization. At the very heart of progressive, vibrant organizations are professionals delivering the highest quality service to the public and to the customers they serve. I would argue that having well trained staff bearing credentials from a rigorous certifying body is a major step toward achieving uniformity and assuring equity in the marketplace.

The first goal for next year is really a modification of a goal from last year. That goal is to continue to enhance our training and Professional Certification Programs. As the Professional Development Committee nears completion of the Professional Certification Exams your Board is directing them to begin developing basic competency exams that can be used by jurisdictions to certify service technicians and to assure their newly hired staff are progressing in their training and are competent to begin their regulatory duties in the marketplace.

Inspiration for my second goal comes from Chairman Ron Hayes in his toast to NCWM at the beginning of our outing, “The most powerful organization that no one has ever heard of” is both a source of pride in our organization and a challenge that must be addressed. As the most impactful consumer protection organization in the country, our stories must be told – our organizations must be supported. The Tool Kit Work Group has had a breakthrough with the video you saw on Tuesday. I am challenging them to continue their efforts in producing more of these videos that can be used either outright or serve as a model for local production. The work group has also made progress on developing models to show the economic impact of weights and measures, and I challenge them to further develop these models and have them ready for publication by our 2016 Annual Meeting.

I want to take a moment to express sincere appreciation to our Associate Members for their work in developing standards and for their leadership in this organization – without you, our work would be impossible.

I also want to thank NIST for their tireless efforts in providing technical support, training, and funding to the Conference and the member jurisdictions.

Thanks also to our friends from Canada that so faithfully participate and bring their technical expertise and friendship to the Conference.

Thank you to the NCWM staff that work hard to make our work and our celebrations successful.

Finally, I want to thank you all in advance for the hard work you will be doing throughout the year.

I think now is a good time to take heed of the words in *Poor Richard’s Almanac*, “A man may speak too long on a good topic,” and close by announcing appointments for 2016.

**The Associate Membership Committee (AMC)** has selected their slate of officers for 2016 and they are:

- Chair, David Calix, NCR

- Vice Chair, Richard Shipman, Rice Lake Weighing Systems, Inc
- Secretary/Treasurer, Bill Callaway, Crompco

I am pleased to announce the following Committee appointments:

**Specifications and Tolerance (S&T) Committee:**

- Rochelle Miller, Wisconsin

**Laws and Regulations (L&R) Committee:**

- Ha Dang, San Diego County, California
- Ethan Bogren, Westchester County, New York

**Professional Development Committee (PDC):**

- Cheryl Ayer, New Hampshire – Cheryl did not attend this year. I thought it curious that the New Hampshire delegates to the Constitutional Convention, John Langdon and Nicolas Gilman, did not attend because their legislature refused to foot the bill. Some things never change.

**Nominating Committee:**

- Ron Hayes Chairman
- John Gaccione, Northeastern Representative
- Stephen Benjamin, Southern Representative
- Kurt Floren, Western Representative
- Randy Jennings, Tennessee
- Joe Gomez, New Mexico
- Charles Carroll, Massachusetts

**Parliamentarian:**

- Lou Straub

**Credentials Committee:**

- Lori Jacobson, South Dakota
- Matt Maiten, Santa Barbra County, California

**Presiding Officers:**

- Laurence Nolan, Los Angeles County, California
- Jack Walsh, Town of Wellesley, Massachusetts
- Tim Chesser, Arkansas
- Steve Harrington, Oregon

**Chaplain:**

- Constantine Cotsoradis

**Sergeants-at-Arms:**

- This positions will be announced later and I intend to fill those positions with individuals from our host state.

Please mark you calendars for the **Interim Conference** – January 17 to 20, 2016, in San Diego, California.

THIS PAGE INTENTIONALL LEFT BLANK

## Special Awards and Recognitions

### Presented at the 100<sup>th</sup> NCWM Annual Meeting

Philadelphia, Pennsylvania

July 21, 2015

### NIST Recognition

The National Conference on Weights and Measures recognizes the National Institute of Standards and Technology for 110 years of dedicated support and cooperation with the National Conference on Weights and Measures in the mission of fair and equitable weights and measures standards for the states and territories of the United States of America.

*“That Equity May Prevail...”*



Figure 1. Chairman Ron Hayes presenting to Carol Hockert, NIST Office of Weights and Measures.



## Present and Past NIST Employees in Attendance



**Figure 2.** Kevin Chesnutwood, Ann Turner, Richard Suiter, Carol Hockert, Otto Warnlof, David Sefcik, Ralph Richter, Tina Butcher, Steven Cook, Henry Oppermann, Clark Cooney, John Barton, and Marc Buttler.

## Measurement Canada Recognition

The National Conference on Weights and Measures recognizes Measurement Canada for promoting equitable commerce between Canada and the United States of America through participation on critical standards development committees, National Type Evaluation Program Sectors, the NCWM Board of Directors, and for participation in the Mutual Recognition Arrangement for type evaluation of weighing and measuring devices between Canada and the National Conference on Weights and Measures.



**Figure 3.** Chairman Ron Hayes presenting to Gilles Vinet, Measurement Canada with Carol Hockert, NIST OWM.



## Lifetime Achievement Award

### Commonwealth of Massachusetts Recognition

The National Conference on Weights and Measures recognizes the Commonwealth of Massachusetts and its Communities for representation at all 100 Annual Meetings held from 1905 to 2015 and for dedicated support in the mission of fair and equitable weights and measures standards for the states and territories of the United States of America.



**Figure 4. Chairman Ron Hayes presenting to Charles Carroll, Massachusetts with Carol Hockert, NIST OWM.**

## Distinguished Service Awards



**Figure 5. Chairman Ron Hayes presenting to Steven Cook, Retired, California.**



**Figure 6. Chairman Ron Hayes presenting to Stephen Langford, Cardinal Scales**



**Figure 7. Chariman Ron Hayes Presenting to Brett Saum, San Luis Obispo County, California.**

### **Contributions Award**



**Figure 8. Chairman Ron Hayes presenting to Michael Cleary, Retired, California.**



## NCWM Retired Members Recognition



Figure 9. Retirees Present Joe Silvestro, Otto Warnlof, Ross Andersen, Charles Gardner, Ann Turner, Michael Cleary, Roger Macey, Steven Cook, Curtis Williams, Dean Ely, Brett Saum, Richard Suiter, David Quinn

## NCWM Past Chairmen Recognition



Figure 10. Ron Hayes – 2015; John Gaccione – 2014; Stephen Benjamin – 2013; Kurt Floren – 2012; Michael Cleary – 2007; Don Onwiler – 2006; Ross Andersen – 2003; Louis Straub – 2001; Charles Gardner – 1996; James Truex – 1995; N. David Smith – 1991.

## Attendance Award Certificate Recipients

### 5 Years Attendance

- Kevin Ferrick
- Roger Macey
- Derek Regal
- Bradley Stotler
- Rob Upright

### 10 Years Attendance

- Mahesh Albuquerque
- Stephen Benjamin
- Rob DeRubeis
- Jason Glass
- Rich Lewis
- Ken Ramsburg
- Prentiss Searles
- David Sefcik

### 15 Years Attendance

- Brett Gurney
- Curtis Williams

### 20 Years Attendance

- Robert Feezor

### 25 Years Attendance

- Gordon Johnson
- N. David Smith

### 35 Years Attendance

- Henry Oppermann
- James Truex

## Door Prizes

### 1<sup>st</sup> Prize: 1950s Wayne Model 90 Dispenser



Figure 11. First Prize Winner, Charles Gardner, Retired, Suffolk County, New York.

### 2<sup>nd</sup> Prize: 1930's Dayton Price Computing Candy Scale



Figure 12. Second Prize Winner, Jason Glass, Kentucky



### 3<sup>rd</sup> Prize: Framed Inspection Decals of all States, Territories, District of Columbia and Navajo Nation



Figure 13. Third Prize Winner: Charles Carroll, Massachusetts.

## Report of the Board of Directors (BOD)

Mr. Ronald Hayes, NCWM Chair  
Missouri

### 100 INTRODUCTION

This is the report of the Board of Directors (BOD) (hereinafter referred to as the “Board”) for the 100<sup>th</sup> Annual Meeting of the National Conference on Weights and Measures (NCWM). This report is based on the Interim Report offered in the NCWM Publication 16, “Board Report,” testimony heard at public hearings, comments received from the regional weights and measures associations and other parties, the addendum sheets issued at the Annual Meeting, and actions taken by the membership at the voting session of the Annual Meeting. The voting items presented below were adopted as presented when this report was approved.

Table A identifies the agenda and appendix items by reference key, title of item, page number, and the appendices by appendix designations. The acronyms for organizations and technical terms used throughout the agenda are identified in Table B. The first three digits of an item’s reference key are assigned from the Subject Series List. The status of each item contained in the report is designated as one of the following: **(D) Developing Item:** the Committee determined the item has merit; however, the item was returned to the submitter or other designated party for further development before any action can be taken at the national level; **(I) Informational Item:** the item is under consideration by the Committee but not proposed for Voting; **(V) Voting Item:** the Committee is making recommendations requiring a vote by the active members of NCWM; **(W) Withdrawn Item:** the item has been removed from consideration by the Committee.

Table C provides a summary of the results of the voting on the Committee’s items and the report in its entirety. Some Voting Items are considered on an individual basis; others may be grouped in a consent calendar. Consent calendar items are Voting Items that the Committee has assembled as a single Voting Item during their deliberation after the Open Hearings on the assumption that the items are without opposition and will not require discussion. The Voting Items that have been grouped into consent calendar items will be listed on the addendum sheets. Prior to adoption of the consent calendar, the Committee entertains any requests from the floor to remove specific items from the consent calendar to be discussed and voted upon individually.

Proposed revisions to the handbook(s) are shown as follows. 1) deleted language is indicated with a **bold face font using strikeouts** (e.g., ~~this report~~), and 2) proposed new language is indicated with an **underscore bold faced font** (e.g., new items). When used in this report the term “weight” means “mass”.

**Note:** It is the policy to use metric units of measurement in publications; however, recommendations received by NCWM technical committees and regional weights and measures associations have been printed in this publication as submitted. Therefore, the report may contain references to U.S. customary units.

---

#### Subject Series List

---

Introduction .....	100 Series
Activity Reports.....	110 Series
Strategic Planning, Policies, and Bylaws.....	120 Series
Financials.....	130 Series
Other Items – Developing Items.....	140 Series

**Table A**  
**Table of Contents**

Reference Key	Title of Item	BOD Page
<b>100</b>	<b>INTRODUCTION1</b>	
<b>110</b>	<b>ACTIVITY REPORTS.....</b>	<b>3</b>
110-1 I	Membership and Meeting Attendance .....	3
110-2 I	NCWM Newsletter and Website .....	5
110-3 I	Meetings Update.....	6
110-4 I	Participation in International Standard Setting.....	7
110-5 I	Associate Membership Committee Activity.....	7
<b>120</b>	<b>STRATEGIC PLANNING, POLICIES, AND BYLAWS.....</b>	<b>8</b>
120-1 I	Strategic Planning.....	8
120-2 I	Regional Support.....	10
120-3 I	Standing Committees Support.....	11
120-4 I	Publication and Distribution of NCWM Work Products.....	13
120-5 V	NCWM Bylaws, Article VII and Article IX.....	14
120-6 V	NCWM Bylaws, Article X, Section 4 – Minimum Votes and Section 9A – Voting – Technical Issues .....	17
120-7 V	Handbook 44 – Introduction.....	21
120-8 V	Handbook 130 – Introduction.....	27
120-9 V	Handbook 133 – Introduction.....	33
<b>130</b>	<b>FINANCIALS.....</b>	<b>36</b>
130-1 I	Financial Report .....	36

**Appendices**

- A Item 110-4: Report of the Activities of the International Organization of Legal Metrology (OIML) and Regional Legal Metrology Organizations ..... A1
- B Item 110-5: Associate Membership Committee (AMC) Agenda and Draft Meeting Minutes..... B1

**Table B**  
**Glossary of Acronyms and Terms**

Acronym	Term	Acronym	Term
AMC	Associate Membership Committee	NTEP	National Type Evaluation Program
CTT	Conformity to Type	OIML	International Organization of Legal Metrology
ISWM	International Society of Weighing and Measuring	OWM	Office of Weights and Measures
MAA	Mutual Acceptance Arrangement	PDP	Principal Display Panel
L&R	Laws and Regulations Committee	PDC	Professional Development Committee
NCWM	National Conference on Weights and Measures	VCAP	Verified Conformity Assessment Program
NIST	National Institute of Standards and Technology	WG	Work Group



**Table C  
Summary of Voting Results**

<i>Reference Key Number</i>	<i>House of Senate Representatives</i>		<i>House of Delegates</i>		<i>Results</i>
	<i>Yeas</i>	<i>Nays</i>	<i>Yeas</i>	<i>Nays</i>	
120-5	Voice Vote				Adopted
120-6	Voice Vote				Adopted
120-7, 120-8, 120-9	Voice Vote				Adopted
To Accept the Report	Voice Vote				Adopted

**Details of All Items  
(In order by Reference Key)**

**110 ACTIVITY REPORTS**

**110-1 I Membership and Meeting Attendance**

Membership has increased again this fiscal year to the highest since 2008, demonstrating a rebound from the recession that began that year. NCWM continues to conduct outreach to stakeholders, and there are very few states or territories that have not maintained membership. The pool of potential members, especially regulatory officials, has become smaller as a result of downsized or eliminated programs resulting from budget cuts. Still, the potential growth in membership is significant and NCWM continues to enhance programs and services, which add value to membership. The Professional Certification Program is an example of a program with potential to greatly impact membership levels after it is fully developed. The 100<sup>th</sup> Annual Meeting in July of 2015 may also have a favorable impact on membership as enthusiasm builds through the year for that special event.

The Board of Directors had considered the implementation of an Organizational Membership plan in an attempt to help agencies and companies that have limits on individual memberships. Unfortunately, it presented serious complications in how memberships are invoiced each year and how online renewals occur. These problems proved to be very difficult to overcome and the consideration has been dropped.

The following is a comparison of NCWM membership levels as of March 1 for recent years. October 1 is the lowest level of membership for the fiscal year because it is the day that any memberships that were not renewed become lapsed.

**Annual Membership Totals**

<b>Year Type</b>	<b>June 2015</b>	<b>June 2014</b>	<b>June 2013</b>	<b>June 2012</b>	<b>June 2011</b>	<b>June 2010</b>	<b>June 2009</b>	<b>June 2008</b>	<b>June 2007</b>
Associate	806	802	818	842	813	814	822	848	863
Foreign Associate	76	64	50	58	62	53	53	56	53
<b>Total Associate</b>	<b>882</b>	<b>866</b>	<b>868</b>	<b>900</b>	<b>875</b>	<b>867</b>	<b>875</b>	<b>904</b>	<b>916</b>
State Government	665	603	558	589	567	565	696	831	825
Local Government	491	492	486	487	495	524	558	554	565
<b>Total Active</b>	<b>1156</b>	<b>1095</b>	<b>1044</b>	<b>1076</b>	<b>1062</b>	<b>1089</b>	<b>1254</b>	<b>1385</b>	<b>1390</b>
NIST	16	16	16	16	16	12	14	15	14
Other Federal Government	11	9	10	11	11	12	10	9	9
Foreign Government	13	13	13	14	14	12	24	22	31
Retired	219	207	198	195	202	196	196	232	221
<b>Total Advisory</b>	<b>259</b>	<b>242</b>	<b>237</b>	<b>236</b>	<b>243</b>	<b>232</b>	<b>244</b>	<b>278</b>	<b>275</b>
<b>Grand Total</b>	<b>2297</b>	<b>2203</b>	<b>2149</b>	<b>2212</b>	<b>2180</b>	<b>2188</b>	<b>2,373</b>	<b>2,567</b>	<b>2,581</b>

**Annual Membership Totals**

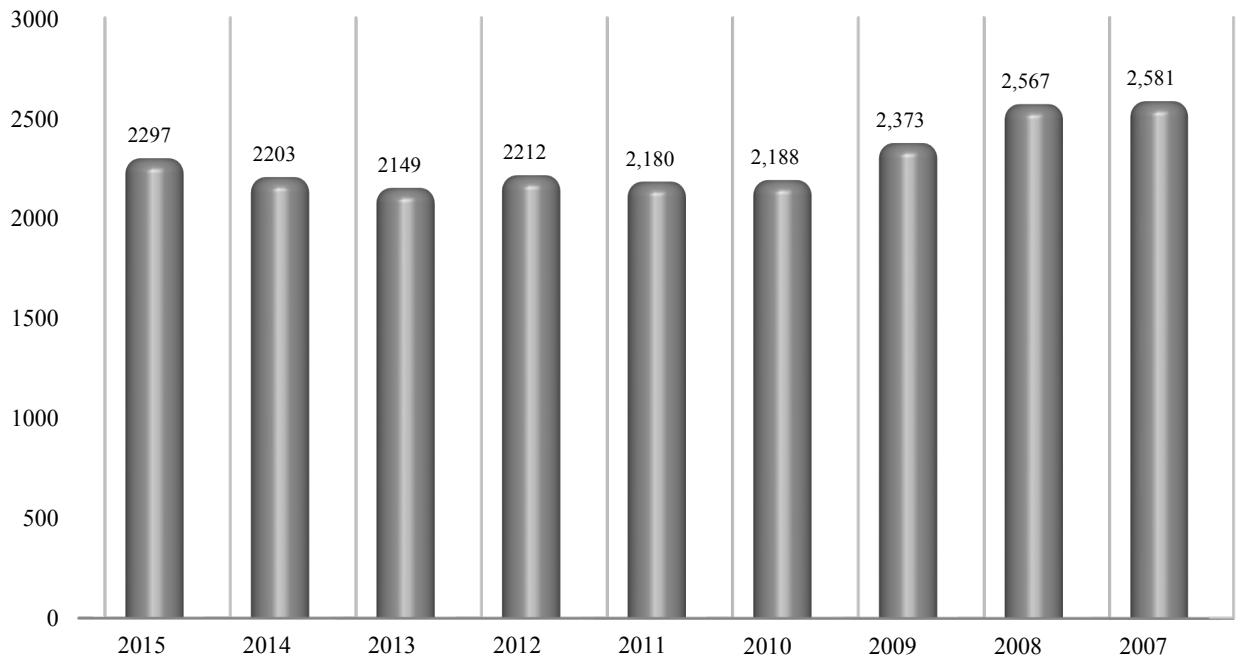

The attendance for the past five Interim Meetings has been exceptional, with the highest being last year in Albuquerque, New Mexico. NCWM had the pleasure of welcoming back a number of jurisdictions to our Interim and Annual meetings in 2013 and 2014. The overall attendance for the 2014 Annual Meeting was the highest in 12 years and included 42 seats in the House of State Representatives. This is an exciting trend as we plan for the upcoming 100<sup>th</sup> Annual Meeting in 2015 in Philadelphia, Pennsylvania. See Item 110-3 for information on this and future meetings.

## **110-2 I NCWM Newsletter and Website**

### **Newsletter:**

The Board continuously considers ways to monitor and improve the content of the newsletter and website. Members are encouraged to bring ideas and articles forward for inclusion in the newsletters. Of particular interest are articles that would be pertinent to field inspectors and the service industry.

### **Website Improvements:**

The NCWM website continues to evolve as ideas are submitted for content enhancement. Many small improvements are made on a regular basis through better use of the space and tools already in place. This year, a small task group of Board members were assembled to study the organization of the website and make recommendations on how the organization can be improved to make information easiest to find.

In February 2014, a list of trainers was added under the “Resource” tab. These are trainers who have acquired training skills through participation in Train-the-Trainer courses sponsored by NIST. Along with the trainers’ names, the page provides the technical areas that each is comfortable presenting in a training class. There is also a page that provides information about upcoming training events around the country. Since training is such a hot topic, the Board’s website task group is considering the creation of a new tab titled “Training.” All of the training resource information would be moved under this new tab.

Among other added features on the new website, the most popular is the mobile-friendly version, which is very affective for the searching the NTEP Certificate database, downloading Certificates of Conformance, and the ability for NTEP applicants to complete their applications online. There are many other added features as well, which make the new website a better customer experience.

Because the mobile-friendly version was so well-received, the NCWM received a request to implement a similar feature for the regional websites. Each of the four regions agreed to the cost of \$550 per site to implement this feature that provides “About,” “Meetings,” and “Contact” in the mobile version with a link to view the full site. The “Meetings” portion provides the user with easy access to meeting information, which includes links for hotels, registration, and meeting documents that will download to the mobile device with impressive speed. This feature is fully implemented on all four regional sites.

Comments and suggestions for improvements to the newsletter and website should be directed to NCWM at (402) 434-4880 or [info@ncwm.net](mailto:info@ncwm.net).

### **Online Position Forum:**

The Board determined the resources necessary to maintain the Online Position Forum is not justified by the limited use. Therefore, the forum will no longer be available. The forum was created to help members prepare for the deliberations and voting at the Annual Meeting. It was a means of providing a place where members could post positions, comments, supporting documents, and learn from others who do the same. In an effort to generate more use of the program, the Forum was reconfigured in 2014 so members could view the comments and positions that others had submitted prior to submitting their own. Unfortunately, usage remained very low. It is possible that the forum could be brought back at some point since the programming is in place.

### **NCWM Visibility:**

NCWM shares many news articles and other items of interest to the weights and measures community on the social networks. This has increased interest in the social network accounts with Facebook, Twitter, and LinkedIn. In 2014,

NCWM contracted with a service provider that offers improved visibility without increased costs. This service provider is optimizing NCWM's visibility on the internet through the combined use of social media and more frequent press releases on a wide variety of subject matters. The goal here is to elevate NCWM as a recognized resource for a vast array of subject matters.

In that first six months of 2014, NCWM averaged one press release per month compared to two or three press releases per year in the past. There will be an effort to take advantage of the savings by maintaining that level of press releases as a way of drawing attention to weights and measures issues and setting NCWM up as a resource for information on those issues.

**Professional Certification Program:**

The website that has the exams for the Professional Certification Program is now fully integrated with NCWM's website so applicants no longer need to wait for staff assistance before they receive their login credentials. Individuals log in at [www.ncwm.net](http://www.ncwm.net) to "purchase" exams, though the fees are waived for members. The fee for non-members is \$75 per exam. The applicant receives an automated e-mail with credentials and instructions for accessing the exam. An applicant who does not pass the exam in the first attempt may have one retake. After that, it will be necessary to reapply.

Certification is now available in six areas, including:

- Small Capacity Weighing Systems Class III
- Medium Capacity Weighing Systems
- Large Capacity Scales
- Retail Motor Fuel Dispensing Systems
- Vehicle Tank Meters
- Package Checking Basic

Please see Item 410-1 for information on the ongoing development of additional exams.

Subject Matter Experts are needed to expedite development of additional exams. Work has begun on exams for Liquefied Petroleum Gas (LPG) Meters and Price Verification. Anyone with expertise in these areas, who wishes to volunteer as a Subject Matter Expert, can contact Mr. Don Onwiler, NCWM Executive Director, at [don.onwiler@ncwm.net](mailto:don.onwiler@ncwm.net) or (402) 434-4871.

There has been concern that NIST Publication 112, "Examination Procedures Outlines" (EPOs) is no longer available. Applicants for Professional Certification must have access to EPOs when taking exams since some questions are based on them. Ms. Carol Hockert, Chief, and NIST OWM, has provided assurance that the EPOs have been updated and will be available electronically on the NIST website after final review.

**110-3 I Meetings Update**

**Interim Meetings:**

- January 17 - 20, 2016 Westin San Diego Gaslamp Quarter Hotel, San Diego, California
- January 8 - 11, 2017 Hyatt Regency San Antonio, San Antonio, Texas
- January 21 - 25, 2018 Sirata Beach Resort, St. Petersburg, Florida

**Annual Meetings:**

- July 24 - 28, 2016 101<sup>st</sup> Annual Meeting: Grand Hyatt Denver, Denver, Colorado
- July 16 - 19, 2017 102<sup>nd</sup> Annual Meeting: Omni William Penn Hotel, Pittsburg, Pennsylvania
- July 2018 103<sup>rd</sup> Annual Meeting: Location to be determined in the Southern region.

NCWM strives to plan meetings in locations that offer comfortable rooms and a variety of entertainment and dining options close by. The following is a brief description of future planned events. We are excited to announce the location for the 2016 Interim Meeting will be held at the Westin San Diego Gaslamp Quarter Hotel. This was the location of a very successful Annual Meeting in 1994 at the Doubletree Hotel and promises to be a great winter venue.

#### **100<sup>th</sup> NCWM Annual Meeting:**

The 100<sup>th</sup> Annual Meeting held at the Sheraton Society Hill in Philadelphia, Pennsylvania, was a great success. In addition to addressing the business of the organization, NCWM celebrated its 100<sup>th</sup> Annual Meeting and 110<sup>th</sup> anniversary. Past NCWM Chairman, Mr. N. David Smith of North Carolina, provided a keynote address at the celebration luncheon. Following the luncheon drawings were held for door prizes that included a 1950s restored gas pump, 1930s restored candy scale, and a framed poster of approval seals from all of the states, territories, the District of Columbia, and the Navajo Nation. The Wednesday evening Special Event was a beautiful evening of fine dining and history at the National Constitution Center. The Board of Directors acknowledges the Planning Committee for their efforts in making the 100<sup>th</sup> NCWM Annual Meeting a wonderful success.

#### **110-4 I Participation in International Standard Setting**

Mr. Ralph Richter, NIST, OWM, provided a report during Open Hearings of the 100<sup>th</sup> NCWM Annual Meeting in Philadelphia, Pennsylvania. An updated report is included as Appendix A to the Report of the Board of Directors.

See the NTEP Committee Agenda for additional reports on NCWM's involvement internationally, including the Mutual Recognition Arrangement (MRA) with Measurement Canada and the Mutual Acceptance Arrangement (MAA) with International Organization of Legal Metrology (OIML).

#### **110-5 I Associate Membership Committee Activity**

The Associate Membership Committee (AMC) is organized in accordance with the Bylaws of the National Conference on Weights and Measures, Inc. In addition, the AMC operates by its own Bylaws, which are available on the Committee pages of [www.ncwm.net](http://www.ncwm.net). AMC meets at least two times per year in conjunction with NCWM Interim and Annual Meetings. It consists of between 5 and 10 members who, amongst themselves, elect officers to serve as Chairman, Vice-Chairman, and Secretary/Treasurer. The AMC has established a reputation of promoting and improving the NCWM and has demonstrated its desire to improve understanding of weights and measures activities in public and private sectors.

The membership dues for Associate members (\$90) are higher than those for Active or Advisory members (\$75). The extra \$15 is not for NCWM, but rather is placed in a separate account referred to as the AMC Fund. While AMC has discretion to allocate the funds in various ways, the Committee receives applications and awards training scholarships from the fund in accordance with their "Guidelines for Selection and Approval of Training Funds," which are posted on the Committee's portion of [www.ncwm.net](http://www.ncwm.net). Downloadable scholarship applications and reimbursement forms are also available there, or applications may be made online.

The criteria to receive the AMC funds for training are as follows:

1. Funding request forms that are complete, specific, and detailed will receive priority attention for approval. Based on the degree of missing or ambiguous information provided, individual requests may not be given any consideration during the AMC review process.
2. Training requests that benefit higher numbers of participants are generally preferred over those for fewer or single-person benefit. Multi-state training, which encourages uniformity, will also be given priority consideration.
3. In general, attending meetings will not be considered training, especially requests for travel expense or attendance fees for NCWM Annual, Interim, or Regional meetings.

4. As a lower priority, requests for the purchase of training materials will be considered, but requests for purchase of assets (such as LCD projectors) will not.
5. Reasonable funding for travel and expenses will be considered if it is necessary to acquire an “expert trainer” that would benefit a high number of weights and measures officials. This will be an option when qualified volunteers are not available.

Members of the AMC were concerned that the funds were underutilized in recent years. However, the AMC is very pleased to see a dramatic increase in the applications for training funds this past year.

Regulatory agencies are encouraged to make use of these funds to improve training opportunities and the expertise of inspection personnel.

AMC members are also looking for new, perhaps innovative ways to play a more effective role in the NCWM structure in an effort to further improve the organization. Some new initiatives being discussed include:

- **Promotional Tool-Kit:** AMC has offered funds to assist NCWM in creating a “tool kit” that weights and measures administrators could use to improve awareness and support through adequate funding of their programs. This tool kit could consist of many elements for targeting media, consumers, government administrators, and legislators. AMC has proposed a work group to pursue this project.
- **Tradeshaw Seminars:** AMC is interested in organizing training or awareness seminars at industry type tradeshaws with the idea of reaching out to the smaller industry groups, which are impacted by the work of NCWM. This effort would be good for the smaller industries, as well as, providing possible increase in NCWM membership and participation.

AMC meetings are open to all registered NCWM meeting attendees. All Associate Members are encouraged to attend these meetings, become familiar with the Committee and offer ideas for how it can further pursue its objectives. (See Appendix B for the AMC Meeting Minutes.)

## 120 STRATEGIC PLANNING, POLICIES, AND BYLAWS

### 120-1 I Strategic Planning

The Executive Director presents a Strategic Plan progress report each year at the fall Board Meeting. The Board conducts a strategic planning session in January at its quarterly meeting just prior to the Interim Meeting. The Board made several updates and changes to the Strategic Plan in January 2015. Members are able to review the Strategic Plan online at [www.ncwm.net](http://www.ncwm.net). The Board welcomes member input.

There are five NCWM Strategic Plan Goals:

1. Enhance NCWM as a national and international resource for measurement standards development.
2. Expand the role of NCWM as a resource for state and local weights and measures programs.
3. Promote uniform training for individuals involved in weights and measures.
4. Continue to improve National Type Evaluation Program (NTEP).
5. Preserve the financial stability of NCWM.

Goal 1: NCWM as a National and International Resource. Under this goal, NCWM has recognized the benefit of participating in other organizations where appropriate as a means of drawing on mutual resources toward common goals and heightening awareness of NCWM. This has been very successful in recent years.

Also as part of this goal, NCWM is hoping to increase consumer group participation in NCWM through outreach efforts.

**Goal 2: Expand the Role of NCWM as a Resource to Officials.**

NCWM issued many more press releases last year than ever before, but the goal is to issue even more. This will raise the level of recognition for NCWM and its membership as a resource for expert information in a vast array of topics.

Another part of this goal is to conduct surveys on occasion that benefit our members. Past surveys have been on budgets, staffing levels, salary grades, fuel quality programs, and more. These surveys provide good benchmarks and will be repeated on occasion to identify trends.

The AMC has expressed interest in assisting with the development of a “tool kit” that can be used by program administrators to generate awareness and support for their programs. This toolkit will contain materials including data supporting a regulatory presence, industry contacts that can be called upon to explain the necessity of a regulatory presence to ensure a level playing field for businesses and consumer protection, and a short video production.

New in 2015, NCWM will post a “Tip of the Month” on its website. This may be posted to regional websites as well. All ideas are welcome and should be addressed to Mr. Onwiler at [don.onwiler@ncwm.net](mailto:don.onwiler@ncwm.net).

Also, new in 2015 is a strategy to develop guidance for retaining personnel and succession planning for positions in state and local weights and measures agencies.

**Goal 3: Promote Uniform Training.**

The Professional Certification Program is a top priority under this goal. Three new exams were added in April 2015 and others are in the development stages. Mr. Ross Andersen serves as Certification Exam Coordinator working with the Professional Development Committee (PDC) and Subject Matter Experts. Volunteer Subject Matter Experts are needed in the areas of Liquefied Petroleum Gas (LPG) Meters and Price Verification.

There is fast-growing interest among service agencies and regulatory agencies for referencing NCWM Professional Certification as a prerequisite to registering/licensing service agents. This would potentially provide one set of exams to satisfy the testing requirements of many states. Private companies are also interested in NCWM Professional Certification as a way of instilling confidence in their customers that they are knowledgeable in regulatory standards. See more discussion on this in the PDC report.

NCWM recently worked with Mr. Andersen to ramp up efforts to retain additional Subject Matter Experts so the program can develop at a faster pace. Anyone interested in assisting with the writing and reviewing of exam questions should contact NCWM.

There are a number of other strategies under Goal 3. A recent advancement toward those strategies includes a cooperative effort with NIST whereby NCWM uses grant funds from NIST to fund travel for approved trainers from around the country to assist with NIST training events. A list of those trainers and the technical areas that each is comfortable presenting training is now available on the NCWM website. Also, new to the website is a list of training opportunities that have been scheduled. Anyone planning a training event that would like to open up the class to other individuals should contact NCWM to have their event posted.

**Goal 4: Continue to Improve NTEP.** NCWM surveyed regulatory officials in 2012 to determine how they access NTEP Certificates of Conformance in the field. This was used as a benchmark. A second survey was conducted in 2014 that demonstrated a significant increase in the number of officials who access NTEP Certificates in the field by using hand held devices to search the Certificate database on the NCWM website. In 2013, NCWM added a mobile friendly version of the website, which makes it much easier to access the NTEP database using hand-held devices such as smart phones. This has contributed to the increased electronic access from the field. As technology advances, NCWM will have a better understanding for how it can make Certificates of Conformance more accessible.

Goal 4 includes a strategy to develop training for weights and measures officials to properly apply information on the Certificates of Conformance. There have been several useful newsletter articles in recent years, and the NTEP staff is developing additional material that should be useful.



A strategy of high priority under this goal is to maintain viable support for NTEP laboratories. NTEP Administrator, Mr. Jim Truex monitors the number of full-time equivalents associated with the authorized laboratories and tracks evaluation time and backlog statistics to ensure that NTEP evaluations can be completed in a timely manner. He reports these statistics quarterly to the NTEP Committee and Board of Directors.

NCWM has a contingency plan in place to ensure evaluation services are maintained for NTEP applicants in the event that insufficient services were available under the current authorized laboratory system. The Board is monitoring its available resources toward that end to ensure NCWM is in a position to implement the worst-case scenario should the need arise. Another strategy toward this goal is the continued development of the Verified Conformity Assessment Program (VCAP), which has already successfully addressed load cells and has moved on to the next device-type category. (See the NTEP Committee Interim Report for more details.)

In 2013, NTEP operated without a field lab for scale evaluations. That, combined with the increasing workload for NTEP staff as a result of VCAP led to the hiring of a new NTEP Specialist to assist in both areas. In January 2014, Mr. Darrell Flocken, formerly of Mettler Toledo, LLC was hired in this capacity. This addition to the NCWM family will greatly enhance NTEP's ability to serve its stakeholders.

As part of Goal 4, NCWM will continue to evaluate its participation in the OIML Mutual Acceptance Arrangement as it expands to include additional device types.

**Goal 5: Preserve Financial Stability.**

This goal was originally to “ensure” financial stability. Financial reports of the past several years indicate that the NCWM is financially stable barring any unexpected circumstances. However, NCWM recognizes it does not have sufficient reserves at this time to fully implement the NTEP contingency plan, which was developed to ensure continued evaluation services if the authorized state laboratories fell victim to budget cuts. The Board has studied NCWM's needs for reserves for NTEP and other potential exposures. This is being balanced with continued efforts to improve services in support of customers and memberships. The Board closely monitors the financial health of the organization through monthly reports and formal reviews at each of the Board meetings. The NCWM finances are formally audited by an accounting firm annually.

**120-2 I Regional Support**

**Meeting Documents on Regional Websites.**

NCWM serves as the clearinghouse for all new proposals being submitted to the regional associations. Efforts continue for streamlining the process while improving documents, reports, and communication. NCWM provides the regional Committees with a report template that contains all of the regions' carryover items and new proposals. The templates are improved each year based on feedback and efforts to streamline the reporting process for everyone. Anyone wishing to recommend improvements should contact Mr. Don Onwiler, NCWM Executive Director, at [don.onwiler@ncwm.net](mailto:don.onwiler@ncwm.net) or (402) 434-4871.

All of the regional websites are hosted through the NCWM. As of 2013, all four regions have now added the e-commerce option for online meeting registrations and membership dues (where applicable) using the NCWM's merchant services to process the payments. NCWM provides the administrative services of transferring those funds to the appropriate regional bank accounts and communicating with regional Treasurers regarding the details of those transfers. There is no additional cost to the regions for this added support. The annual fee to NCWM from each region remains at \$200 for unlimited support unless programming is required. In 2014, each of the regions invested \$550 as a one-time cost to program the websites with a mobile version.

Chairman John Gaccione reported at the 99<sup>th</sup> NCWM Annual Meeting that the regional websites are being used more frequently as a tool for meeting information and meeting registrations. To suggest improvements or corrections to the content of the website, contact Mr. Tyler Reeder, Project Coordinator, at [tyler.reeder@ncwm.net](mailto:tyler.reeder@ncwm.net) or (402) 434-4880.

## 120-3 I Standing Committees Support

### Committee Orientation.

NCWM conducts Committee Orientation for committee chairs and new committee members every fall at NIST, OWM in Gaithersburg, Maryland. The location enables full participation by all NIST Technical Advisors. The focus is on leadership, administrative processes, roles and responsibilities, and review of the *NCWM Committee Member Handbook*. The discussions at Committee Orientation have led to improvements each year to the *NCWM Committee Handbook* and to the report templates, which regional Committees use to submit their reports for inclusion in NCWM Publication 15.

### Task Groups, Subcommittees, and Steering Committees.

Task Groups (TG), Subcommittees, and Steering Committees are created by appointment by the NCWM Chairman. A TG is given a specific charge, and it reports to the appropriate NCWM standing committee. A TG will disband at the completion of its assignment. A Subcommittee is charged with ongoing responsibilities in support of a Standing Committee in a specific field of expertise. A Steering Committee is charged with unbiased fact-finding, which will assist NCWM membership in decision processes for difficult issues. A Steering Committee will disband upon completion of its specific charge.

NCWM offers resources to these TGs and Subcommittees including meeting space at Interim and Annual Meetings, conference calling and web meeting services, group e-mail services, a dedicated web page for posting and archiving documents related to their work, and broadcast e-mail services to reach targeted audiences. Additionally, NIST, OWM has provided Technical Advisors and web meeting forums. All of these tools enable year-around progress of task group and Subcommittee work.

Because NCWM TGs and Subcommittees report directly to NCWM Standing Committees or Board of Directors, any new proposals may appear in NCWM Publication 15 without first being vetted through a regional association. Any such proposals are properly vetted through the open hearings of NCWM.

The Board expresses great appreciation to the volunteers who serve in support of the work of this organization.

#### Natural Gas Steering Committee:

The Laws and Regulations (L&R) Committee heard spirited debate at the 2013 Interim Meeting Open hearings on a proposal to recognize the Diesel Gallon Equivalent and Diesel Liter Equivalent as the method of sale for compressed and liquefied natural gas; similar to the Gasoline Gallon and Liter Equivalents that were recognized in 1994. Opponents argue that a method of sale by mass is preferred.

NCWM Chairman Stephen Benjamin formed a new Natural Gas Steering Committee in 2013 to address rising issues as the compressed and liquefied natural gas markets rapidly expand. The Steering Committee will report to the Laws and Regulations Committee. Its charge is to gather information that will assist NCWM Membership in the decision process as model standards are developed for the sale of liquefied and compressed natural gas.

#### Chair

Mr. Ethan Bogren  
Westchester County Weights and Measures  
Westchester County, NY  
Phone: (914) 261-2268  
E-mail: [neb2@westchestergov.com](mailto:neb2@westchestergov.com)

#### Fuels and Lubricants Subcommittee:

This group reports to the L&R Committee. For more information, contact:

#### Chair

Dr. Matthew Curran  
Florida Department of Agriculture and Consumer Service  
3125 Conner Boulevard, Building 2  
Mail Stop L2

Tallahassee, FL 32399-1650  
Phone: (850) 921-1570 Fax: (850) 921-1548  
E-Mail: [Matthew.Curran@FreshFromFlorida.com](mailto:Matthew.Curran@FreshFromFlorida.com)

**Packaging and Labeling Subcommittee:**

The group reports to the L&R Committee. For more information, contact:

**Chair**

Mr. Christopher Guay  
Procter and Gamble, Co.  
One Procter and Gamble Plaza  
Cincinnati, OH 45202  
Phone: (513) 983-0530  
Fax: (513) 983-8984  
E-mail: [guay.cb@pg.com](mailto:guay.cb@pg.com)

**Moisture Loss Task Group:**

The group reports to the Laws and Regulations Committee. For more information, contact:

**Chair**

Mr. Kurt Floren  
LA County Agricultural Commissioner / Weights and Measures  
12300 Lower Azusa Road  
Arcadia, CA 91006  
Phone: (626) 575-5451  
Fax: (626) 350-3243  
E-mail: [kfloren@acwm.lacounty.gov](mailto:kfloren@acwm.lacounty.gov)

**Multi-Point Calibration Task Group:**

The group reports to the Specifications and Tolerances Committee. For more information, contact:

**Chair**

Ms. Julie Quinn  
Minnesota Department of Commerce  
14305 South Cross Drive, Suite 150  
Burnsville, MN 55306  
Phone: (651) 539-1555  
Fax: (952) 435-4040  
E-mail: [julie.quinn@state.mn.us](mailto:julie.quinn@state.mn.us)

**Promotional Tool Kit Task Group:**

This group will develop tools that may be used by weights and measures agencies to promote awareness and support and adequate funding for their programs. The tools will target three separate audiences:

- Consumers;
- Regulated Industries; and
- Legislators, Governors, and Agency Administrators.

Tools may include case studies, data, short-segment video productions, public service announcements, etc.

**Chair**

Mr. Stephen Benjamin  
North Carolina Department of Agriculture  
Raleigh, NC 27699

Phone: (919) 707-3225  
 E-mail: [steve.benjamin@ncagr.gov](mailto:steve.benjamin@ncagr.gov)

**Organometallics Task Group:**

The group reports to the Fuels and Lubricants Subcommittee and L&R Committee. For more information, contact:

**Chair**

Mr. Randy Jennings  
 Tennessee Department of Agriculture  
 P.O. Box 40627  
 Nashville, TN 37204  
 Phone: (615) 837-5327  
 Fax: (615) 837-5335  
 E-mail: [randy.jennings@tn.gov](mailto:randy.jennings@tn.gov)

**120-4 I Publication and Distribution of NCWM Work Products**

**Source:**

NCWM Packaging and Labeling Subcommittee (2015)

**Purpose:**

Develop a plan for publication and distribution of new NCWM work products.

**Background/Discussion:**

The NCWM Package and Labeling Subcommittee (PALS) is developing a document that provides principles and recommendations to capture best practices for the many different kinds of existing quantity related statements that appear on package Principal Display Panels (PDPs). These are statements that are present in addition to the required declaration of net quantity. The practice of adding these expressions has increased significantly over the past decade, and it is recognized that some statements can help consumers make fair value comparisons while others arguably may confuse or actually mislead consumers.

The principles and recommendations under development by PALS are intended to provide both manufacturers and regulators with a standard and guidance regarding best practices for these types of statements in order to provide increased uniformity and statement integrity. Rather than attempt to create regulations covering these topics, which would require involvement of multiple federal agencies, PALS believes the development of principles and recommendations provides an actionable and reasonable approach for bringing standardization and consistency to this topic.

The NCWM Board of Directors was asked to consider how to manage a NCWM standard like this, which may not be a new regulation intended for inclusion in one of the NIST Handbooks. Options that were suggested include:

- a new section in a NIST Handbook;
- a stand-alone document;
- a new publication;
- a standards archive; or
- other.

At the January 2015 Board of Directors Meeting, a suggestion was made to publish guidance documents electronically and make them available to the general public on the NCWM website. The Board will consider a system of naming and organizing these types of publications.

While PALS expects to utilize the normal NCWM item review and adoption process through the L&R Committee for these principles and recommendations, the question for the Board of Directors is where the principles and recommendations will “live” once they are adopted.

PALS believes this is a strategic decision requiring Board deliberation since other NCWM work products are likely to be developed in response to emerging issues. PALS anticipates that this item could be ready for submission to the L&R Committee as early as the 2016 NCWM Interim Meeting.

## 120-5 V NCWM Bylaws, Article VII and Article IX

(This item was adopted.)

**Source:**

NCWM Board of Directors (2015)

**Purpose:**

Provide better organization of information.

**Item under Consideration:**

Amend NCWM Bylaws as follows:

### **Article VII – Duties of the Directors and Appointive Officials**

#### **Section 1 – Board of Directors**

**The Board of Directors is the governing body of the Corporation and is authorized to make all decisions relating thereto, including but not limited to the following:**

- 1. conducts the business of the National Conference on Weights and Measures, Inc., as a Corporation, which at a minimum includes (a) overseeing the preparation and filing of the biennial report and fee with the Nebraska Secretary of State in compliance with Neb. Rev. Stat. Section 21-301.**
- 2. reviews and approves the budget;**
- 3. selects the place and dates for each meeting of the Corporation;**
- 4. fixes all fees including but not limited to meeting registrations, fees associated with NTEP administration, publications, and the annual membership fee;**
- 5. advises the responsible individual or organization, as designated by the Chairman, with respect to the programs for the meetings of the Corporation and its committees, and makes recommendations to the Corporation, the Corporation officers, and the committee chairmen;**
- 6. reviews an annual audit report prepared by an external auditor whose services are retained by the corporation to assess the accuracy of the financial statements, the accounting principles used, and evaluate overall financial statement presentation; and**
- 7. establishes and periodically reviews the policies and procedures for the corporation.**

**The Board of Directors, in the interval between meetings of the Corporation:**

- 1. authorizes meetings of Corporation committees in accordance with the provisions of Article VIII, Section 3;**

**2. authorizes expenditures that are not in the budget; and**

**3. acts for the Corporation in all routine or emergency situations that may arise.**

**Special meetings of the Board may be held at the discretion of the Chairman, and may take place in any manner technologically possible, including, but not limited to, telephone conference calls and electronic mail. A quorum shall consist of seven members of the Board. Voting may be cast in any manner prescribed by the Chairman. All questions before the Board of Directors will be decided whenever practical, by voice vote or by ballot, and will be decided on the basis of the majority of votes cast.**

**The Board serves as a policy and coordinating body in matters of national and international significance which may include such areas as metrication; the interaction with organizations such as the International Organization of Legal Metrology (OIML), American National Standards Institute (ANSI), International Organization for Standardization (ISO), ASTM International, National Conference of Standards Laboratories (NCSL), and such internal matters as may be required.**

## **Section 24 – Chairman**

The Corporation Chairman has broad authority including, but not limited to, the authority to make policy decisions on behalf of the Corporation and take such actions as are necessary to put these decisions into effect. The Chairman is the principal presiding officer at the meetings of the Corporation and of the Board of Directors, makes appointments to the several standing and special purpose Committees, and appoints other Corporation officials to serve during his or her term of office. **The Chairman, on behalf of the Board, annually presents a report on Corporation activities.**

[Remaining sections will be editorially renumbered as needed.]

## **Article IX – Committees**

### **Section 3 – National Type Evaluation Program (NTEP) Committee**

The NTEP Committee is comprised of five members: the Immediate Past Chairman, the Chairman, and the Chair-Elect of the Conference and two regional Directors from the Board of Directors. The NTEP Committee must include at least one member from each of the four regions. The NTEP Administrator shall serve in an advisory role to the NTEP Committee.

The NTEP Committee may develop recommendations to the Board of Directors for the NTEP fees including, but not limited to, application fees to obtain a NTEP Certificate of Conformance and the annual maintenance fee for retaining a NTEP Certificate of Conformance. The NTEP Committee is responsible for the operation of the NTEP program with respect to its fiscal management, providing guidance related to the activities of the program, establishing **Publication 14 NTEP technical policy and procedures, and recommending Publication 14 administrative policies to the Board for approval. and procedures.**

Through the Chairman of the NTEP Committee, members are appointed from the Advisory, Active, and Associate Members to the Technical Committees of the National Type Evaluation Program. The Associate members represent the interest of manufacturers, retail sales organizations, and users of commercial devices. The Active members represent the interest of government officials and the consumer. These Committees make technical, policy and procedural recommendations to the NTEP Committee for implementation.

### **Section 4 – Ad Hoc Committees, Subcommittees, Task Forces, and Study Groups**

*Ad Hoc* Committees, Subcommittees, Task Forces, and Study Groups are appointed by the Corporation Chairman from the active, advisory, or associate membership, in any combination, as the need arises or the Corporation requests. All **such groups-committees** are subject to an annual review by the Board.

## Section 5 – Duties and Fields of Operation of Board of Directors and Committees

### A. Board of Directors

~~The Board of Directors is the governing body of the Corporation and is authorized to make all decisions relating thereto, including but not limited to the following:~~

- ~~1. conducts the business of the National Conference on Weights and Measures, Inc., as a Corporation, which at a minimum includes (a) overseeing the preparation and filing of the biennial report and fee with the Nebraska Secretary of State in compliance with Neb. Rev. Stat. Section 21-301.~~
- ~~2. reviews and approves the budget;~~
- ~~3. selects the place and dates for each meeting of the Corporation;~~
- ~~4. fixes all fees including but not limited to meeting registrations, fees associated with NTEP administration, publications, and the annual membership fee;~~
- ~~5. advises the responsible individual or organization, as designated by the Chairman, with respect to the programs for the meetings of the Corporation and its committees, and makes recommendations to the Corporation, the Corporation officers, and the committee chairmen; and~~
- ~~6. reviews an annual audit report prepared by an external auditor whose services are retained by the corporation to assess the accuracy of the financial statements, the accounting principles used, and evaluate overall financial statement presentation.~~

~~The Board of Directors, in the interval between meetings of the Corporation:~~

- ~~1. authorizes meetings of Corporation committees in accordance with the provisions of Article VIII, Section 3,~~
- ~~2. authorizes expenditures that are not in the budget, and~~
- ~~3. acts for the Corporation in all routine or emergency situations that may arise.~~

~~Special meetings of the Board may be held at the discretion of the Chairman, and may take place in any manner technologically possible, including, but not limited to, telephone conference calls and electronic mail. A quorum shall consist of 7 members of the Board. Voting may be cast in any manner prescribed by the Chairman. All questions before the Board of Directors will be decided whenever practical, by voice vote or by ballot, and will be decided on the basis of the majority of votes cast.~~

~~The Board serves as a policy and coordinating body in matters of national and international significance which may include such areas as metrication; the interaction with organizations such as the International Organization of Legal Metrology (OIML), American National Standards Institute (ANSI), International Organization for Standardization (ISO), ASTM International, National Conference of Standards Laboratories (NCSL), and such internal matters as may be required.~~

~~The Chairman, on behalf of the Board, annually presents a report on Corporation activities.~~

[Remaining sections will be editorially renumbered as needed.]

**Background/Discussion:**

As part of the effort to improve clarity of NCWM operations, the task force recommended several changes to the NCWM Bylaws. At the fall 2014 Board of Directors meeting, the Board agreed to propose these modifications to the Conference.

One change is to move the duties of the Board of Directors from Article IX to Article VII. A new subsection is proposed to clarify the role of the Board of Directors in establishing and reviewing NCWM policies and procedures. A clarification is proposed to Article IX, Section 3, National Type Evaluation Program (NTEP) Committee to clarify that the NTEP Committee establishes NTEP technical policy and recommends NTEP administrative policy to the Board of Directors for approval. A modification is also proposed for Article IX, Section 4 to clarify that all groups described there are subject to annual review by the Board.

All amendments to Bylaws must be approved by a vote of the general membership at the Annual Meeting.

**120-6 V NCWM Bylaws, Article X, Section 4 – Minimum Votes and Section 9A – Voting – Technical Issues**

(This item was adopted.)

**Source:**

NCWM Board of Directors (2015)

**Purpose:**

Remove confusion among membership in the proper application of the Bylaws based on voting results for technical items in the two-house system.

**Item under Consideration:**

Amend NCWM Bylaws. Article X as follows:

**Section 4 – Minimum Votes Needed for an Official Vote of a House**

**A. House of State Representatives**

A minimum of 27 votes in favor of, or 27 votes in opposition to, an issue must be cast for the vote to be considered official. If 54 or more votes are cast in the House of State Representatives, a simple majority of the total votes is required to pass (or defeat) the issue.

**B. House of Delegates**

A minimum of 27 votes in favor of, or 27 votes in opposition to, an issue must be cast for the vote to be considered official. If more than 54 total votes are cast, a simple majority rules. Should a tie vote occur, or if the minimum votes in support or opposition are not cast, the issue is decided by the vote of the House of State Representatives.

- 
- 
- 

**Section 9A – Voting - Technical Issues**

At the conclusion of the debate (if authorized) on a motion, there shall be a call for the vote by voice vote, a show of hands, standing, or electronic count. **The requirements for an official vote in a house are found in Article X Section 4.**



**A. Motion Accepted If:**

1. ~~a minimum of 27 members of the House of State Representatives votes Yea.~~ the House of State Representatives casts an official vote in favor of the item;  
and
2. ~~a majority of the members of the House of Delegates votes Yea~~ the House of Delegates casts an official vote in favor of the item or the House of Delegates fails to cast an official vote. (a minimum of 27 Yea votes required);<sup>1</sup>

**B. Motion Rejected If:**

1. ~~a minimum of 27 members of the House of State Representatives votes Nay~~ the House of State Representatives casts an official vote in opposition of the item;  
and
2. ~~a majority of the members of the House of Delegates votes Nay~~ the House of Delegates casts an official vote in opposition of the item or the House of Delegates fails to cast an official vote. (a minimum of 27 Nay votes required);<sup>1</sup>

**C. ~~Split Vote:~~ Issue Returned to Committee for Future Consideration If:**

- a. The House of Representatives fails to cast an official vote;  
or
- b. An official vote is cast in each house but one house votes yea and the other house votes nay.  
When a split vote is recorded or the minimum number of votes supporting or opposing an issue is not obtained in the House of State Representatives, the issue is returned to the Standing Committee for further consideration.

~~The Committee may drop the issue or reconsider it for submission the following year.~~ The issue cannot be recalled for another vote at the same Annual Meeting

---

<sup>1</sup>~~If the minimum number of votes required to pass or fail an issue is not cast in the House of Delegates, the issue will be determined by the vote of the House of State Representatives.~~

## Voting on Technical Issues: The Two-House System

The vote by a house is “Official” if: The number of Yea votes is 27 or more

**OR**

The number of Nay votes is 27 or more

		House of Delegates						
		Majority Vote Yea		Majority Vote Nay		Tie Vote		
		Official Vote (≥ 27)	Unofficial Vote (< 27)	Official Vote (≥ 27)	Unofficial Vote (< 27)			
House of State Representatives	Majority Vote Yea	Official Vote (≥ 27)	<b>Motion Accepted</b>	<b>Motion Accepted</b>	Returned to Committee	<b>Motion Accepted</b>	<b>Motion Accepted</b>	
		Unofficial Vote (< 27)	Returned to Committee	Returned to Committee	Returned to Committee	Returned to Committee	Returned to Committee	
	Majority Vote Nay	Official Vote (≥ 27)	Returned to Committee	<b>Motion Rejected</b>	<b>Motion Rejected</b>	<b>Motion Rejected</b>	<b>Motion Rejected</b>	
		Unofficial Vote (< 27)	Returned to Committee	Returned to Committee	Returned to Committee	Returned to Committee	Returned to Committee	
	Tie Vote		Returned to Committee	Returned to Committee	Returned to Committee	Returned to Committee	Returned to Committee	

**Background/Discussion:**

In 1977, NCWM was presented with a proposal to implement the two-house system for voting on national standards. The new system was adopted and implemented in 1978 and has remained unchanged since that time.

The Board of Directors brought this proposal forward upon learning that the membership was conflicted in how the bylaws for the two-house voting system are interpreted and applied. The proposal does not change how the bylaws are applied. It provides clarity.

Prior to 1978, NCWM had very simple voting procedures whereby every official in attendance had an equal vote and the majority ruled. This voting system had been criticized for many years, leading to the changes in 1978. The 1977 report provided six main concerns that the new two-house system was intended to address.

1. New procedures should prohibit “packing the Conference” by any one jurisdiction.
2. Participation of all state and local weights and measures officials should be encouraged and perpetuated. All weights and measures officials should be allowed floor and voting privileges.
3. Economic and geographic bias due to travel restrictions and Conference location should be eliminated.
4. Conference actions should represent national consensus since the NISR Handbook 44 specifications and tolerances, model laws, and model regulations are to be national standards promoting national uniformity.
5. The voting procedure should reflect the basic structure of authority in the diverse weights and measures organizational structures existing in the United States.
6. The votes of each state should be recorded.

One of the goals mentioned was to eliminate economic or geographic bias resulting from travel restrictions and meeting locations. Another was to prohibit “packing of the Conference” by any one jurisdiction. These concerns were addressed by creating a House of State Representatives where there is just one vote per state and a minimum of 27 votes is required in favor or opposition before any action can be taken.

Another goal was to encourage and perpetuate the participation of all state and local officials, so a second house was established called the House of Delegates. This house is made up of all other state and local regulatory officials in attendance. This house also has a 27-vote minimum yea or nay to qualify as an official vote. The following passage from the 1977 report has been used to clarify why this minimum vote count was established in the House of Delegates.

The intent of the House of Delegates procedure is to assure a consensus opinion of weights and measures officials on an issue. An additional consideration is to provide representation while preventing a relatively small group from controlling a vote by “packing” the vote in the House of Delegates. This could occur when the number of delegates in the House of Delegates is much smaller than the number in the House of State Representatives. While this occurrence may not be likely, this problem can be circumvented by requiring the minimum number of votes cast in favor of or in opposition to an issue also be 27 in the House of Delegates to pass or fail an issue.

The table, which is part of this new proposal, illustrates how the bylaws are applied when the vote count in the House of Delegates results in a tie, or the minimum of 27 votes is not cast in favor of, or in opposition to the item. In those instances, the issue is decided by the vote in the House of State Representatives as long as it does achieve an official vote. This table, along with improved wording in the proposal, was added after the 2015 NCWM Interim Meeting where the Board heard some comments that demonstrated ongoing confusion.

An attendee at the 2015 Interim Meeting commented that the bylaws weaken the vote of the city and county officials who reside in the House of Delegates by allowing a decision to be made by the vote of the states when attendance is too low in the House of Delegates to achieve an official vote. He suggested that the 27-vote minimum in that house is unfair. Based on these concerns, the Board reviewed the actual vote counts on all technical items since 1978. There are three instances over the 37-year span where an action was taken based on a vote of the House of State Representatives because the House of Delegates either did not achieve the minimum 27 votes for or against the item or there was a tie vote.

Year	Item	State Representatives		Delegates		Outcome
		Yea	Nay	Yea	Nay	
1980	204-4A	31	6	24	10	The item passed
1995	101-1C	28	14	29	29	The item passed
2005	221-1	33	5	23	7	The item passed

In a similar review of the voting records, the Board found that there were nine instances where both houses achieved the official vote, but one house voted in favor and the other opposed. In those instances, no action was taken.

Another attendee commented at the 2015 Interim Meeting that the proposed language was still confusing. Based on that comment, the Board has modified the proposal with improved wording and added a table to clearly illustrate how the bylaws are applied. It has been suggested this table should appear in NCWM Publication 16 as well as the proposed change to the bylaws.

All amendments to Bylaws must be approved by a vote of the general membership at the Annual Meeting.

## 120-7 V NIST Handbook 44 – Introduction

(This item was adopted.)

### Source:

NCWM Board of Directors (2015)

### Purpose:

Remove information from the Introduction Section of NIST Handbook 44, “Specifications, Tolerances, and Other Technical Requirements for Weighing and Measuring Devices,” and place it in the NCWM Policy Manual.

### Item under Consideration:

Amend NIST Handbook 44 Introduction as follows:

#### A. Source.

The specifications, tolerances and other technical requirements in this handbook comprise all of those adopted by the National Conference on Weights and Measures, Inc. (NCWM). Contact at:

1135 M Street, Suite 100  
Lincoln, NE 68508

Phone: (402) 434-4880  
Fax: (402) 343-4878

E-mail: [info@ncwm.net](mailto:info@ncwm.net)  
URL: [www.ncwm.net](http://www.ncwm.net)

The NCWM is supported by the National Institute of Standards and Technology (NIST), which provides its Executive Secretary and publishes some of its documents. NIST also develops technical publications for use by weights and measures agencies; these publications may subsequently be endorsed or adopted by NCWM.

~~The NCWM Committee on Specification and Tolerances (the Committee), acting at the request of the Conference or upon its own initiative, prepares with the technical assistance of the National Institute of Standards and Technology (NIST), proposed amendments or additions to the material adopted by NCWM (see Paragraph C). Such revisions, amendments, or additions are then presented to NCWM as a whole, where they are discussed by weights and measures officials and representatives of interested manufacturers, industries, consumer groups, and others. Eventually the proposals of the Committee, which may have been amended from those originally presented, are voted upon by the weights and measures officials, following the voting procedures in the NCWM Bylaws. A national consensus is required on all items adopted by the NCWM. A specification, tolerance, or other technical requirement is adopted when a majority of the states’ representatives, and other voting delegates favoring such adoption, vote for approval.~~

All of the specifications, tolerances, and other technical requirements given herein are recommended by NCWM for official promulgation in and use by the states in exercising their control of commercial weighing and measuring apparatus. A similar recommendation is made with respect to the local jurisdictions within a state in the absence of the promulgation of specifications, tolerances, and other technical requirements at the state level.

**(Amended 2015)**

## **B. Purpose.**

The purpose of these technical requirements is to eliminate from use, weights and measures and weighing and measuring devices that give readings that are false, that are of such construction that they are faulty (that is, that are not reasonably permanent in their adjustment or will not repeat their indications correctly), or that facilitate the perpetration of fraud, without prejudice to apparatus that conforms as closely as practicable to the official standards.

## **C. Amendments**

~~The Committee on Specifications and Tolerances of NCWM serves as a mechanism for consideration of amendments or additions to the specifications, tolerances, and other technical requirements.~~

Proposed Amendments to NIST Handbook 44 are deliberated and developed by NCWM's Committee on Specifications and Tolerances before presentation to the general membership for a vote. In some instances amendments that significantly affect other NIST Handbooks may be processed jointly by two or more committees.

Amendments to the handbooks are made in accordance with NCWM procedures and policies. The process begins at the regional weights and measures association meetings in the fall of each year and is culminated at the NCWM Annual Meeting in July. After passing through one or more of the regional associations the proposed amendment is placed on the agenda of the appropriate NCWM committee for consideration at NCWM's Interim Meeting in January and after final deliberation and development by the committee the amendment may be presented to the membership for a vote at the annual NCWM meeting in July. NCWM policy provides for exceptions to the process to accommodate urgent or priority items. NIST staff provides technical assistance and advice throughout the process.

The policy is available on the NCWM website at [www.NCWM.net](http://www.NCWM.net). For information on the regional weights and measures associations, visit [www.ncwm.net/resource/regional\\_associations](http://www.ncwm.net/resource/regional_associations).

(Amended 2015)

## **D. Submission of Agenda Items—Preamble.**

~~NCWM Bylaws require that its officers and committees observe the principles of due process for the protection of the rights and interests of affected parties. Specifically, it requires that committees and officers: (a) give reasonable advance notice of contemplated studies, items to be considered for action, and tentative or definite recommendations for conference vote, and (b) provide that all interested parties have an opportunity to be heard.~~

## **E. Submission Process.**

~~Anyone introducing an item to the Committee must initially use the regional weights and measures associations to consider its merits. Using the regional associations ensures discussion and evaluation of items at the grassroots level by involving the regional members in the development, evaluation, and justification of proposals. The regions include the Central, Northeastern, Southern, and Western Weights and Measures Associations. For information on the regional associations, visit [www.newm.net](http://www.newm.net). To submit a proposal to a regional association, obtain *Form 15: Proposal to Amend Handbooks* at [www.newm.net](http://www.newm.net) or by contacting NCWM via email at [info@newm.net](mailto:info@newm.net). Complete the form and submit it electronically in Microsoft Word format to NCWM at [info@newm.net](mailto:info@newm.net) and copy the Executive Secretary at [owm@nist.gov](mailto:owm@nist.gov). An example of the Form 15 template is provided at the end of this section. Instructions for completing the form are included with the electronic version of this template. To ensure that your proposal is included on the regional meeting agenda, submit at least two weeks in advance of the fall regional meeting. Regional meeting schedules are available on the NCWM website.~~

**F. Procedures.**

The NCWM Committee will consider items according to the following procedures:

1. ~~NCWM Committees receive new items from regional associations, National Type Evaluation Technical Committees (Sectors), task groups, and subcommittees and as defined in Sections H and I. All items to be considered by the Committee for action at the upcoming Interim Meeting must be submitted electronically in Word format to NCWM by November 1.~~
2. ~~NCWM will ensure that all committee members and technical advisors receive complete copies of all new items for consideration at the upcoming NCWM Interim Meeting.~~

**G. Criteria for Inclusion on the NCWM Committee's Agenda.**

1. ~~Any item approved by at least one regional association and received by the November 1 deadline will be automatically placed on the Committee's Interim Meeting agenda.~~
2. ~~Items that have not been approved by a regional association, but which are received by November 1, will be evaluated by the Committee using the criteria in Section H, Exceptions to Policy, and Section I, Committee Agenda.~~
3. ~~Any proposal received after the November 1 deadline, but prior to the Interim Meeting, will be evaluated by the Committee according to Section H, Exceptions to Policy and Section I, Committee Agenda. Only those items determined to be a national "priority" will be included on its agenda.~~
4. ~~Proposals must be in writing and must include:~~
  - a. ~~a concise statement of the item or problem outlining the purpose and national need for its consideration. An electronic copy of the background material and proposed amendment(s) should be submitted in Microsoft Word format on a CD, DVD, or by electronic mail sent to [info@ncwm.net](mailto:info@ncwm.net);~~
  - b. ~~background material, including test data, analysis of test data, or other appropriately researched and documented material for the Committee to evaluate when deciding its position or future activity on the proposal;~~
  - c. ~~proposed solutions to problems stated in specific language and in amendment form as changes to Conference documents; and~~
  - d. ~~if a proposal involves a new area of weights and measures activity, practical, realistic, and specific recommendations for laws or regulations to be adopted and test methods to be utilized to provide for proper enforcement.~~

~~When proposals are to modify or add requirements to existing publications, such as Handbook 44, the proposal should:~~

- 1) ~~identify the pertinent portion, section, and paragraph of the existing publication that would be changed (e.g., Section 1.10. General Code, G A.1. Commercial Law Enforcement Equipment);~~
- 2) ~~provide evidence of consistency with other NCWM publications such as with other specific device code sections;~~
- 3) ~~provide evidence of consistency with federal laws and regulations (e.g., U.S. Department of Agriculture [USDA]); and~~

- ~~4) relay the positions of businesses, industries, or trade associations affected by the proposal including supporting and opposing points of view.~~

## ~~H. Exceptions to Policy for Submission of Items to a NCWM Committee Agenda; Submission of "Priority" Items.~~

~~The Committee will use the following criteria to evaluate items that have not been approved by a regional association, but have been received by the November 1 deadline. If an item is received after the November 1 deadline, it will be included on the agenda if the Committee determines that it is a national "priority."~~

### ~~Criteria for Inclusion on the Committee's Agenda When No Regional Association Has Approved the Item.~~

- ~~1. Items must have significant legal impact on weights and measures laws and/or regulations involving:
  - ~~a. court cases/attorney general opinions; or~~
  - ~~b. preemption by federal statute or regulation; or~~
  - ~~c. conflicts with international standards; or~~
  - ~~d. items which could affect health and safety.~~~~
- ~~2. The Committee may contact parties that are potentially affected by an item (e.g., trade associations, industry, and consumer groups) for comments. The Committee may consider these comments and any other information in determining if the item should be included on its agenda.~~
- ~~3. When the Committee determines that it should consider an item as a "priority" (using the criteria in 1.), the item will be handled in the following manner:
  - ~~a. A "priority" item received prior to the Interim Meeting may be added to the Interim Meeting agenda by a majority vote of the Committee.~~
  - ~~b. A "priority" item received after the Interim Meeting may be added to the Committee's Annual Meeting agenda as:
    - ~~1) a discussion item by a majority vote of the Committee; or~~
    - ~~2) as a voting item by a majority vote of the Committee and the NCWM Board of Directors.~~~~~~

## ~~I. Committee Agenda.~~

- ~~1. The Committee will review items that have been submitted and selected by a majority vote to be included on its agenda. The Committee will only include those items that have been:
  - ~~a. approved by at least one of the regional associations; or~~
  - ~~b. forwarded by other committees, subcommittees, NTETC Sectors, task forces, or work groups, or those items that meet the criteria in Section H, Exceptions to Policy.~~~~
- ~~2. The Committee will publish an agenda (NCWM Publication 15) that identifies the items to be discussed during the Interim Meeting. This agenda will be distributed to members approximately~~



~~30 days prior to the meeting. The agenda will be provided upon request to all other interested parties.~~  
~~(Amended 1998)~~

#### ~~J. Interim Meeting.~~

- ~~1. The Committee shall hold public hearings at the Interim Meeting for the purpose of discussing and taking comments on all agenda items.~~
- ~~2. Upon request, the Committee will provide the opportunity for presentations by government officials, industry representatives, consumer groups, or other interested parties during the Interim Meeting. Requests to make presentations must be received by the Committee Chairman or Technical Advisor at least two weeks prior to the start of the meetings.~~

#### ~~K. Interim Meeting Report.~~

- ~~1. Items under consideration by the Committee and about which the Committee offers comments or recommendations to NCWM to act upon during the Annual Meetings will be included in the Committee's Interim Reports published in the Annual Meeting Program and Committee Reports (NCWM Publication 16).~~
- ~~2. The Annual Meeting Program and Committee Reports will be prepared and distributed to Conference members approximately three months prior to the NCWM Annual Meeting.~~

#### ~~L. Classifications for Agenda Items.~~

~~At the Interim Meeting, the Committee can classify proposals in one of the following ways as:~~

- ~~1. "Voting" These are items the Committee believes are fully developed and ready for final consideration of the voting membership. Each item has either received majority support from the Committee or the Committee has reached agreement that it is ready for voting status to let NCWM membership decide. The Committee has the ability to remove items from the voting agenda at the Annual Meeting by changing the status prior to a vote of the NCWM membership. The Committee may amend voting items during the course of the Annual Meeting based on additional information received following the Interim Meeting and testimony received at the Annual Meeting. These items may also be amended by the voting membership during the voting session of the Annual Meeting following the procedures outlined in the NCWM Bylaws; or~~
- ~~2. "Informational" These items are deemed by the Committee to have merit. They typically contain a proposal to address the issue at hand and a meaningful background discussion for the proposal. However, the Committee wants to allow more time for review by stakeholders and possibly further development to address concerns. The Committee has taken the responsibility for any additional development of Informational items. For particularly difficult items, the Committee may assign the item to an existing Subcommittee under its charge or request that the NCWM Chair appoint a special task group that reports to the Committee. At the Annual Meeting, the Committee may change the status of Informational items, but not to Voting status because the item has not been published as such in advance of the meeting; or~~
- ~~3. "Developing" These items are deemed by the Committee to have merit, but are found to be lacking enough information for full consideration. Typically the item will have a good explanation of the issue, but a clear proposal has yet to be developed. By assigning Developing status, the Committee has sent the item back to the source or assigned it to some other entity outside the scope of the Committee with the responsibility of further development. The Committee Report will provide the source with clear indication of what is necessary to move the item forward for full consideration. The item will be carried in the Committee agenda in bulletin board fashion with~~

~~contact information for the person or organization that is responsible for the development. Since the Committee is not required to receive testimony on Developing items, this status should be carefully implemented so as not to weaken the standards development process; or~~

- ~~4. "Withdrawn" — These are items that the Committee has found to be without merit. The Committee's determination to withdraw an item should not be based on the Committee's opinion alone, but on the input received from stakeholders. The Committee's report will contain an explanation for the withdrawal of the item. Once an item appears in NCWM Publication 16 as Withdrawn, the status of that item may not be amended. The item may be reintroduced through the regional associations for consideration as a new item.  
(Amended 2013)~~

#### **M. Comments on Interim Reports.**

- ~~1. Weights and measures officials, industry representatives, and all others are encouraged to submit written comments on items in the Committees' Interim Reports.~~
- ~~2. All comments on the Interim Meeting Report must be submitted to the Committee with a copy to the Executive Secretary no later than one month preceding the opening of the Annual Meeting.~~

#### **N. Annual Meeting.**

- ~~1. The Committee will hold a public hearing at the Annual Meeting to discuss issues on its agenda.~~
- ~~2. Those who want to speak on an item during the public hearings should request time from the Committee Chairman. The Committee Chairman may impose time limits on presentations, the discussion of a question, or the discussion of a proposed amendment.~~

#### **O. Final Committee Reports and Conference Action.**

- ~~1. Following the public hearings, the Committee will prepare its final report for action by the voting membership of the Conference. Copies of the final report will be provided to the membership prior to the voting session for that report.~~
- ~~2. The Chairman of the Committee will present the final report of the Committee to the Conference body. A vote will be taken on items, proposals, or sections in the report as circumstances require. The Conference will vote on the entire final report as presented in accordance with established Conference voting procedures. Parliamentary procedures according to Robert's Rules of Order, as amended by NCWM Bylaws, must be adhered to in the presentation of, and any action on, a Standing Committee report.  
(Amended 1998)~~

[Remaining sections will be editorially renumbered as needed.]

#### **Background/Discussion:**

At several recent NCWM meetings there were questions raised about the procedures used to modify handbooks and the meeting process. At the July 2014 Board of Directors Meeting in Detroit, Michigan, the NCWM Board formed a task group to review NCWM policy and bylaws. The goal of the task group is to propose modifications that would improve the clarity of NCWM procedures. Recommendations from the task group were presented to Board at their fall 2014 meeting. These modifications require Conference action.

The Introductions to NIST Handbooks 44, *Specifications, Tolerances, and Other Technical Requirements for Weighing and Measuring Devices*, and 130, *Uniform Laws and Regulations in the areas of Legal Metrology and Engine Fuel Quality*, contain information on the procedures to amend the handbook. NIST Handbook 133, *Checking*

*the Net Contents of Package Goods*, does not contain this information or even an Introduction. The Board agreed to recommend removing the procedures for amending the handbooks from the Introductions in NIST Handbooks 44 and 130. In addition to the proposed amendment to NIST Handbooks 44 and 130, an appropriate Introduction is proposed for NIST Handbook 133.

The information that would be removed from NIST Handbooks 44 and 130 has been incorporated into a new NCWM Policy 3.4.1. Procedures to Modify NIST Handbooks. In addition, the Board will review NCWM Policy 3.1.5. to ensure that the new policy will be available to all stakeholders including non members. Policy 3.1.5. currently limits online access of the Policy Manual to Members Only. This would not be appropriate for the new policy mentioned here.

Amendments to NIST Handbooks 44, 130, and 133 require a vote of the Conference.

## 120-8 V Handbook 130 – Introduction

(This item was adopted.)

NCWM Board of Directors (2015)

### Purpose:

Remove information from the Introduction Section of NIST Handbook 130, “Uniform Laws and Regulations in the Areas of Legal Metrology and Engine Fuel Quality,” and place it in the NCWM Policy Manual.

### Item under Consideration:

Amend NIST Handbook 130, Introduction as follows:

#### A. Source

The Uniform Laws and Regulations<sup>1</sup> in this handbook comprise all of those adopted by the National Conference on Weights and Measures, Inc. (NCWM) Contact NCWM at:

1135 M Street, Suite 100  
Lincoln, NE 68508

Phone: (402) 434-4880  
Fax: (402) 343-4878

E-mail: [info@ncwm.net](mailto:info@ncwm.net)  
URL: [www.ncwm.net](http://www.ncwm.net)

The NCWM is supported by the National Institute of Standards and Technology (NIST), which provides its Executive Secretary and publishes its documents. NIST also develops technical publications for use by weights and measures agencies; these publications may subsequently be endorsed or adopted by the NCWM.

~~The NCWM Committee on Laws and Regulations (the Committee), acting at the request of NCWM or upon its own initiative, prepares with the technical assistance of the National Institute of Standards and Technology (NIST), proposed amendments or additions to the material adopted by NCWM (see Paragraph C). Such revisions, amendments, or additions are then presented to NCWM as a whole where they are discussed by weights and measures officials and representatives of interested manufacturers, industries, consumer groups, and others. Eventually the proposals of the Committee, which may have been amended from those originally presented, are voted upon by the weights and measures officials, following the voting procedures in the NCWM Bylaws. A national consensus is required on all items adopted by the NCWM. A Uniform Law or Regulation is adopted when a majority of the states’ representatives, and other voting delegates favoring such adoption, vote for approval.~~

<sup>1</sup> When referring to the Uniform Laws and Regulations in Handbook 130, Laws and Regulations will be capitalized. When referring to general federal or state laws and regulations, no capitalization will be used.

All of the Uniform Laws and Regulations given herein are recommended by NCWM for adoption by states when reviewing or amending their official laws and regulations in the areas covered. A similar recommendation is made with regard to the local jurisdictions within a state in the absence of the promulgation of such laws and regulations at the state level.

**(Amended 2015)**

## **B. Purpose**

The purpose of these Uniform Laws and Regulations is to achieve, to the maximum extent possible, uniformity in weights and measures laws and regulations among the various states and local jurisdictions in order to facilitate trade between the states, permit fair competition among businesses, and provide uniform and sufficient protection to all consumers in commercial weights and measures practices.

## **C. Amendments**

~~The Committee on Laws and Regulations of NCWM serves as a mechanism for consideration of amendments or additions to the Uniform Laws and Regulations.~~

Proposed amendments to NIST Handbook 130 are deliberated and developed by NCWM's Committee on Laws and Regulations before presentation to the general membership for a vote. In some instances amendments that significantly affect other NIST Handbooks may be processed jointly by two or more committees.

Amendments to the handbooks are made in accordance with NCWM procedures and policies. The process begins at the regional weights and measures association meetings in the fall of each year and is culminated at the NCWM Annual Meeting in July. After passing through one or more of the regional associations, the proposed amendment is placed on the agenda of the appropriate NCWM committee for consideration at NCWM's Interim Meeting in January, and after final deliberation and development by the committee the amendment may be presented to the membership for a vote at the annual NCWM meeting in July. NCWM policy provides for exceptions to the process to accommodate urgent or priority items. NIST staff provides technical assistance and advice throughout the process.

The policy is available on the NCWM website at [www.NCWM.net](http://www.NCWM.net). For information on the regional weights and measures associations, visit [www.newm.net/resource/regional\\_associations](http://www.newm.net/resource/regional_associations).

**(Amended 2015)**

## **~~D. Submission of Agenda Items — Preamble~~**

~~NCWM Bylaws require that its officers and committees observe the principles of due process for the protection of the rights and interests of affected parties. Specifically, it requires that the committees and officers: (a) give reasonable advance notice of contemplated studies, items to be considered for action, and tentative or definite recommendations for conference vote, and (b) provide that all interested parties have an opportunity to be heard.~~

## **~~E. Submission Process~~**

~~Anyone introducing an item to the Committee must initially use the regional weights and measures associations to consider its merits. Using the regional associations ensures discussion and evaluation of items at the grassroots level by involving the regional members in the development, evaluation, and justification of proposals. The regions include the Central, Northeastern, Southern, and Western Weights and Measures Associations. For information on the regional associations, visit [www.newm.net](http://www.newm.net).~~

~~To submit a proposal to a regional association, obtain *Form 15: Proposal to Amend Handbooks* at [www.newm.net](http://www.newm.net) or by contacting NCWM via email at [info@newm.net](mailto:info@newm.net). Complete the form and submit it~~

~~electronically in Microsoft Word format to NCWM at info@newm.net and copy the Executive Secretary at owm@nist.gov. An example of the Form 15 template is provided at the end of this section. Instructions for completing the form are included with the electronic version of this template. To ensure that your proposal is included on the regional meeting agenda, submit at least two weeks in advance of the fall regional meeting. Regional meeting schedules are available on the NCWM website.~~

## ~~F. Procedures~~

~~The NCWM Committee will consider items according to the following procedures:~~

- ~~1. NCWM Committees receive new items from regional associations, National Type Evaluation Technical Committees (Sectors), task groups, and subcommittees and as defined in Sections H and I. All items to be considered by the Committee for action at the upcoming Interim Meeting must be submitted electronically in Microsoft Word format to NCWM by November 1.~~
- ~~2. NCWM will ensure that all committee members and technical advisors receive complete copies of all new items for consideration at the upcoming NCWM Interim Meeting.~~

## ~~G. Criteria for Inclusion on the NCWM Committee's Agenda~~

- ~~1. Any item approved by at least one regional association and received by the November 1 deadline will be automatically placed on the Committee's Interim Meeting agenda.~~
- ~~2. Items that have not been approved by a regional association, but which are received by November 1, will be evaluated by the Committee using the criteria in Section H, Exceptions to Policy, and Section I, Committee Agenda.~~
- ~~3. Any proposal received after the November 1 deadline, but prior to the Interim Meeting, will be evaluated by the Committee according to Section H, Exceptions to Policy and Section I, Committee Agenda. Only those items determined to be a national "priority" will be included on its agenda.~~
- ~~4. Proposals must be in writing and must include:
 
  - ~~a. a concise statement of the item or problem outlining the purpose and national need for its consideration. An electronic copy of the background material and proposed amendment(s) should be submitted in a Microsoft Word format on a CD ROM, DVD, or by electronic mail sent to info@newm.net;~~
  - ~~b. background material, including test data, analysis of test data, or other appropriately researched and documented material for the Committee to evaluate when deciding its position or future activity on the proposal;~~
  - ~~e. proposed solutions to problems stated in specific language and in amendment form as changes to Conference documents; and~~
  - ~~d. if a proposal involves a new area of weights and measures activity; practical, realistic, and specific recommendations for laws or regulations to be adopted and test methods to be utilized to provide for proper enforcement.~~~~

~~When proposals are to modify or add requirements to existing publications, such as Handbook 130, *Uniform Laws and Regulations in the Areas of Legal Metrology and Engine Fuel Quality*, or Handbook 133, *Checking the Net Content of Packaged Goods*, the proposal should:~~

- ~~1) identify the pertinent portion, section, and paragraph of the existing publication that would be changed (e.g., Uniform Method of Sale of Commodities Regulation, Section 8.2, paragraph (b));~~
- ~~2) provide evidence of consistency with other NCWM publications such as with other uniform laws and regulations;~~
- ~~3) provide evidence of consistency with federal laws and regulations (e.g., U.S. Department of Agriculture [USDA] or Federal Trade Commission [FTC] regulations); and~~
- ~~4) relay the positions of businesses, industries, or trade associations affected by the proposal including supporting and opposing points of view.~~

## ~~H. Exceptions to Policy for Submission of Items to the NCWM Committee Agenda; Submission of “Priority” Items~~

~~The Committee will use the following criteria to evaluate items that have not been approved by a regional association, but have been received by the November 1 deadline. If an item is received after the November 1 deadline, it will be included on the agenda if the Committee determines that it is a national “priority.”~~

~~Criteria for Inclusion on the Committee’s Agenda When No Regional Association Has Approved the Item.~~

- ~~1. Items must have significant legal impact on weights and measures laws and/or regulations involving:
  - ~~a. court cases/attorney general opinions; or~~
  - ~~b. preemption by federal statute or regulation; or~~
  - ~~c. conflicts with international standards; or~~
  - ~~d. items which could affect health and safety.~~~~
- ~~2. The Committee may contact parties that are potentially affected by an item (e.g., trade associations, industry, and consumer groups) for comments. The Committee may consider these comments and any other information in determining if the item should be included on its agenda.~~
- ~~3. When the Committee determines that it should consider an item as a “priority” (using the criteria in 1.), the item will be handled in the following manner:
  - ~~a. A “priority” item received prior to the Interim Meeting may be added to the Interim Meeting agenda by a majority vote of the Committee.~~
  - ~~b. A “priority” item received after the Interim Meeting may be added to the Committee’s Annual Meeting agenda as:
    - ~~1) a discussion item by a majority vote of the Committee; or~~
    - ~~2) as a voting item by a majority vote of the Committee and the NCWM Board of Directors.~~~~~~

## ~~I. Committee Agenda~~

- ~~1. The Committee will review items that have been submitted and selected by a majority vote to be included on its agenda. The Committee will only include those items that have been:~~

- a. ~~approved by at least one of the regional associations; or~~
  - b. ~~forwarded by other committees, subcommittees, NTETC Sectors, task forces, or work groups, or those items that meet the criteria in Section H, Exceptions to Policy.~~
2. ~~The Committee will publish an agenda (NCWM Publication 15) that identifies the items to be discussed during the Interim Meeting. This agenda will be distributed to members approximately 30 days prior to the meeting. The agenda will be provided upon request to all other interested parties.~~  
(Amended 1998)

#### ~~J. Interim Meeting~~

- 1. ~~The Committee shall hold public hearings at the Interim Meeting for the purpose of discussing and taking comments on all agenda items.~~
- 2. ~~Upon request, the Committee will provide the opportunity for presentations by government officials, industry representatives, consumer groups, or other interested parties during the Interim Meeting. Requests to make presentations must be received by the Committee Chairman or Technical Advisor at least two weeks prior to the start of the meetings.~~

#### ~~K. Interim Meeting Report~~

- 1. ~~Items under consideration by the Committee, and about which the Committee offers comments or recommendations to NCWM to act upon during the Annual Meeting, will be included in the Committee's Interim Report published in the Annual Meeting Program and Committee Reports (NCWM Publication 16).~~
- 2. ~~The Annual Meeting Program and Committee Reports will be prepared and distributed to Conference members approximately three months prior to the NCWM Annual Meeting.~~

#### ~~L. Classifications for Agenda Items~~

~~At the Interim Meeting, the Committee can classify proposals in one of three ways as:~~

- 1. ~~"Voting" These are items the Committee believes are fully developed and ready for final consideration of the voting membership. Each item has either received majority support from the Committee or the Committee has reached agreement that it is ready for voting status to let NCWM membership decide. The Committee has the ability to remove items from the voting agenda at the Annual Meeting by changing the status prior to a vote of the NCWM membership. The Committee may amend voting items during the course of the Annual Meeting based on additional information received following the Interim Meeting and testimony received at the Annual Meeting. These items may also be amended by the voting membership during the voting session of the Annual Meeting following the procedures outlined in the NCWM Bylaws; or~~
- 2. ~~"Informational" These items are deemed by the Committee to have merit. They typically contain a proposal to address the issue at hand and a meaningful background discussion for the proposal. However, the Committee wants to allow more time for review by stakeholders and possibly further development to address concerns. The Committee has taken the responsibility for any additional development of Informational items. For particularly difficult items, the Committee may assign the item to an existing Subcommittee under its charge or request that the NCWM Chair appoint a special task group that reports to the Committee. At the Annual Meeting, the Committee may change the status of the items, but not to Voting status because the item has not been published as such in advance of the meeting; or~~



- ~~3. “Developing” — These items are deemed by the Committee to have merit, but are found to be lacking enough information for full consideration. Typically the item will have a good explanation of the issue, but a clear proposal has yet to be developed. By assigning Developing status, the Committee has sent the item back to the source or assigned it to some other entity outside the scope of the Committee with the responsibility of further development. The Committee Report will provide the source with clear indication of what is necessary to move the item forward for full consideration. The item will be carried in the Committee agenda in bulletin board fashion with contact information for the person or organization that is responsible for the development. Since the Committee is not required to receive testimony on developing items, this status should be carefully implemented so as not to weaken the standards development process; or~~
- ~~4. “Withdrawn” — These are items that the Committee has found to be without merit. The Committee's determination to withdraw should not be based on the Committee's opinion alone, but on the input received from stakeholders. The Committee's report will contain an explanation for the withdrawal of the item.~~

~~Once an item appears in NCWM Publication 16 as Withdrawn, the status of that item may not be amended.~~

~~The item may be reintroduced through the regional associations for consideration as a new item.~~

~~(Amended 2013)~~

#### ~~M. Comments on Interim Reports~~

- ~~1. — Weights and measures officials, industry representatives, and all others are encouraged to submit written comments on items in the Committee's Interim Report.~~
- ~~2. — All comments on the Interim Meeting Report must be submitted to the Committee with a copy to the Executive Secretary no later than one month preceding the opening of the Annual Meeting.~~

#### ~~N. Annual Meeting~~

- ~~1. — The Committee will hold a public hearing at the Annual Meeting to discuss items on its agenda.~~
- ~~2. — Those who want to speak on an item during the public hearing should request time from the Committee Chairman. The Committee Chairman may impose time limits on presentations, the discussion of a question, or the discussion of a proposed amendment.~~

#### ~~O. Final Committee Reports and Conference Action~~

- ~~1. — Following the public hearings, the Committee will prepare its final report for action by the voting membership of the Conference. Copies of the final report will be provided to the membership prior to the voting session for that report.~~
- ~~2. — The Chairman of the Committee will present the final report of the Committee to the Conference body. A vote will be taken on items, proposals, or sections in the report as circumstances require. The Conference will vote on the entire final report as presented in accordance with established Conference voting procedures. Parliamentary procedures according to Robert's Rules of Order, as amended by NCWM Bylaws, must be adhered to in the presentation of, and any action on, a Standing Committee report.~~

~~(Amended 1998)~~

[Remaining sections will be editorially renumbered as needed.]

**Background/Discussion:**

At several recent NCWM meetings, there were questions raised about the procedures used to modify handbooks and the meeting process. At the July 2014 Board of Directors Meeting in Detroit, Michigan, the NCWM Board formed a task group to review NCWM policy and bylaws. The goal of the task group is to propose modifications that would improve the clarity of NCWM procedures. Recommendations from the task group were presented to Board at their fall 2014 meeting. These modifications require Conference action.

The Introductions to NIST Handbooks 44 and 130 contain information on the procedures to amend the handbook. NIST Handbook 133 does not contain this information or even an Introduction. The Board agreed to recommend removing the procedures for amending the handbooks from the Introductions in NIST Handbooks 44 and 130. The information that would be removed would be used to create a new NCWM policy on how the handbooks are amended. In addition to the proposed amendment to Handbooks 44 and 130, an appropriate Introduction is proposed for NIST Handbook 133.

The information that would be removed from Handbooks 44 and 130 has been incorporated into a new NCWM Policy 3.4.1. Procedures to Modify NIST Handbooks. In addition the Board will review NCWM Policy 3.1.5. to ensure that the new policy will be available to all stakeholders including nonmembers. Policy 3.1.5. currently limits online access of the Policy Manual to Members Only. This would not be appropriate for the new policy mentioned here.

Amendments to NIST Handbooks 44, 130, and 133 require a vote of the Conference.

**120-9 V Handbook 133 – Introduction**

(This item was adopted.)

**Source:**

NCWM Board of Directors (2015)

**Purpose:**

Create an Introduction Section to NIST Handbook 133, “Checking the Net Contents of Packaged Goods,” similar to those found in NIST Handbooks 44 and 130.

**Item under Consideration:**

Amend NIST Handbook 133 as follows:

**Introduction****A. Source**

**The information and procedures in this handbook comprise all of those adopted by the National Conference on Weights and Measures, Inc. (NCWM) [www.ncwm.net](http://www.ncwm.net). Contact NCWM at:**

1135 M Street, Suite 100  
Lincoln, NE 68508

Phone: (402) 434-4880  
Fax: (402) 343-4878

E-mail: [info@ncwm.net](mailto:info@ncwm.net)  
URL: [www.ncwm.net](http://www.ncwm.net)

**The NCWM is supported by the National Institute of Standards and Technology (NIST), which provides its Executive Secretary and publishes its documents. NIST also develops technical publications for use by weights and measures agencies; these publications may subsequently be endorsed or adopted by the NCWM.**

**This handbook is recommended by NCWM for adoption by states when reviewing or amending their official laws and regulations on testing the net contents of packaged goods. A similar recommendation is made with regard to the local jurisdictions within a state in the absence of the promulgation of such laws and regulations at the state level.**

## **B. Purpose**

**This handbook has been prepared as a procedural guide for the compliance testing of net content statements on packaged goods. Compliance testing of packaged goods is the determination of the conformance of the results of the packaging, distribution, and retailing process (the packages) to specific legal requirements for net content declarations. This handbook has been developed primarily for the use of government officials. However, commercial and industrial establishments packaging, distributing, and selling commodities will find this handbook useful.**

**In conducting compliance testing, the conversion of quantity values from one measurement system to another (e.g., from the metric system to the U.S. customary system) should be handled with careful regard to the implied correspondence between the accuracy of the data and the number of digits displayed. In all conversions, the number of significant digits retained should ensure that accuracy is neither sacrificed nor exaggerated. For this 2016 edition of NIST Handbook 133, “Checking the Net Contents of Packaged Goods” all dimensions for test procedures, devices, or environments have been rounded to two significant digits (e.g., 2.5 cm to 1.0 in) or to a precision level applicable to the test equipment (e.g., 200 kPa for 25 psi and 35 MPa for 5000 psi).**

## **C. Amendments**

**Amendments to NIST Handbook 133 are deliberated and developed by NCWM’s Committee on Laws and Regulations before presentation to the general membership for a vote. In some instances, amendments that significantly affect other NIST Handbooks may be processed jointly by two or more committees.**

**Amendments to the handbooks are made in accordance with NCWM procedures and policies. The process begins at the regional weights and measures association meetings in the fall of each year and is culminated at the NCWM Annual Meeting in July. After passing through one or more of the regional associations, the proposed amendment is placed on the agenda of the appropriate NCWM committee for consideration at NCWM’s Interim Meeting in January. After final deliberation and development by the committee, the amendment may be presented to the membership for a vote at the NCWM Annual Meeting in July. The NCWM policy provides for exceptions to the process to accommodate urgent or priority items. NIST staff provides technical assistance and advice throughout the process.**

**The policy is available on the NCWM website at [www.NCWM.net](http://www.NCWM.net). For information on the regional weights and measures associations, visit [www.ncwm.net/resource/regional\\_associations](http://www.ncwm.net/resource/regional_associations).**

## **D. Revisions to the Handbook**

**NIST publishes a new edition of this handbook after significant changes are made. If NIST determines that amendments made by NCWM were minor or editorial in nature an annual publication will not be published. Instead, NIST will issue a notice that the current edition is still valid and will publish a list of the changes on the NIST website.**

## **E. Annotation**

**Beginning in 1971, amendments or additions to sections in the handbook are annotated at the end of each section (e.g., “Amended 1982”) as a service to those states that are planning to update their own laws or regulations. The references to each revision and the year will enable government officials and industry members to trace the rationale for the changes by referring to the Report of the XXX National Conference on Weights and Measures (also know as the NCWM Annual Report) for the year indicated and make decisions regarding adoptions and amendments to their laws and regulations.**

## **F. Effective Enforcement Dates of Regulations**

**Unless otherwise specified, the new or amended sections are intended to become effective and subject to enforcement on January 1 of the year following adoption by NCWM.**

## **G. Section References**

**In most references made to specific sections or subsections in this handbook, the word “Section” followed by the section number is used.**

## **H. The International System of Units**

**The “International System of Units,” “SI,” or “SI Units” means the modernized metric system as established in 1960 by the General Conference on Weights and Measures (GIPM). In 1988, Congress amended the Metric Conversion Act of 1975 (see Section 5164 of Public Law 100-418) to declare that it is the policy of the United States to designate the metric system of measurement as the preferred measurement system for U.S. trade and commerce, and it further defined “the metric system of measurement” to be the International System as established by the GIPM and as interpreted or modified for the United States by the Secretary of Commerce. (See Metric Conversion Law 15 U.S.C. 205; NIST Special Publication 330, “The International System of Units (SI)”; NIST Special Publication 814, “Guide for the Use of the International System of Units (SI)”; Interpretation of the International System of Units [the Metric System of Measurement] for the United States in the “Federal Register” of May 16, 2008, [“Federal Register” Vol. 73, No. 96] or subsequent revisions). In 1992, Congress amended the Federal Fair Packaging and Labeling Act (FPLA) to require certain consumer commodities to include the appropriate SI units along with the customary inch-pound units in their quantity statements.**

### **I. “Mass” and “Weight.”** [NOTE 1, page 7]

**The mass of an object is a measure of the object’s inertial property or the amount of matter it contains. The weight of an object is a measure of the force exerted on the object by gravity or the force needed to support it. The pull of gravity on the earth gives an object a downward acceleration of about 9.8 m/s<sup>2</sup>. In trade and commerce and everyday use, the term “weight” is often used as a synonym for “mass.” The “net mass” or “net weight” declared on a label indicates that the package contains a specific amount of commodity exclusive of wrapping materials. The use of the term “mass” is predominant throughout the world and is becoming increasingly common in the United States.**

**(Added 1993)**

### **J. Use of the Terms “Mass” and “Weight.”** [NOTE 1, page 7]

**When used in this handbook, the term “weight” means “mass.” The term “weight” appears when U.S. customary units are cited or when both inch-pound and SI units are included in a requirement. The terms “mass” or “masses” are used when only SI units are cited in a requirement. The following note appears where the term “weight” is first used in a law or regulation.**

**NOTE 1: When used in this law (or regulation), the term “weight” means “mass.” (See paragraphs I. “Mass” and Weight and J. Use of the Terms “Mass” and “Weight” in Introduction section of NIST Handbook 133 for an explanation of these terms.)**

**(Added 1993)**

#### **Background/Discussion:**

At several recent NCWM meetings there were questions raised about the procedures used to modify handbooks and the meeting process. At the July 2014 Board of Directors Meeting in Detroit, the NCWM Board formed a task group to review NCWM policy and bylaws. The goal of the task group is to propose modifications that will improve the clarity of NCWM procedures. Recommendations from the task group were presented to Board at their fall 2014 meeting. These modifications require conference action.

The Introductions to Handbooks 44 and 130 contain information on the procedures to amend the handbook. Handbook 133 does not contain this information or even an introduction. The Board agreed to recommend removing the procedures for amending the handbooks from the introductions in Handbooks 44 and 130. This information that would be removed would be used to create a new NCWM policy on how the Handbooks are amended. In addition to the proposed amendment to Handbooks 44 and 130, an appropriate introduction is proposed for Handbook 133.

The information that would be removed from Handbooks 44 and 130 has been incorporated into a new NCWM Policy 3.4.1. Procedures to Modify NIST Handbooks. In addition the Board will review NCWM Policy 3.1.5 to ensure that the new policy will be available to all stakeholders including nonmembers. Policy 3.1.5. presently limits online access of the Policy Manual to Members Only. This would not be appropriate for the new policy mentioned here.

Amendments to Handbooks 44, 130 and 133 require a vote of the Conference.

## **130 FINANCIALS**

### **130-1 I Financial Report**

NCWM operates on a fiscal year of October 1 through September 30. Budgets are set to be conservative on projected revenues and realistic on anticipated expenses.

The Board continues to monitor its ability to fully implement contingency plans based on potential costs compared to reserve funds.

The following is the balance sheet as of June 30, 2015 in comparison with the same time the previous year. Assets in the balance sheet are inflated by the by the NIST Training Initiative Grant, which was awarded to NCWM in 2012. Those funds are earmarked for specific training activities. Assets are also inflated by the Associate Membership Fund. This money is accumulated through the additional \$15 dues paid by NCWM Associate Members and is spent at the discretion of the Associate Membership Committee in accordance with Committee Bylaws.

<b>ASSETS</b>	<b>June 30, 2015</b>	<b>June 30, 2014</b>
Current Assets	\$	\$
Checking/Savings		
Associate Member Fund	30,386.05	32,998.67
NIST Training Grant	38,720.00	14,860.67
Certificates of Deposit	1,171,664.56	1,162,359.04
Checking	42,910.00	28,119.95
Savings	291,052.89	263,309.23
Total Checking/Savings	<u>1,574,733.50</u>	<u>\$ 1,501,647.56</u>
Accounts Receivable	420.00	995.00
Other Current Assets	89,233.63	140,066.80
Other Assets	13,417.29	12,322.40
<b>TOTAL ASSETS</b>	<b><u>1,677,804.42</u></b>	<b><u>\$ 1,655,031.76</u></b>
<b>LIABILITIES &amp; EQUITY</b>		
Liabilities		
Current Liabilities	33,451.35	26,795.84
Total Liabilities	<u>33,451.35</u>	<u>26,795.84</u>
Equity		
Designated – Associate Membership	30,386.05	32,998.67
Designated – NIST Training	38,720.00	14,860.67
Unrestricted Net Assets	1,373,165.90	1,366,715.87
Net Income	202,081.12	213,660.71
Total Equity	<u>1,644,353.07</u>	<u>1,628,235.92</u>
<b>TOTAL LIABILITIES &amp; EQUITY</b>	<b><u>1,677,804.42</u></b>	<b><u>\$ 1,655,031.76</u></b>

The following is a graphic view of past 10 fiscal years based on year-end audit reports. The spike in expenses in 2008 reflects the cost transition from contracted management services to hired employees and procured office space, furniture, computers, etc. The chart shows significant savings in the following years although NCWM has invested significantly in new initiatives during that time.

A significant investment was made in 2013 to rebuild of the NCWM website. Because the website is considered a depreciable asset, the investment does not reduce NCWM's net assets. Expenses in 2014 and going forward will increase with the addition of a new staff person in the National Type Evaluation Program. This new staff position is necessary to handle increased workload associated with the Conformity Assessment Program. Mr. Darrell Flocken was hired as the NTEP Specialist and will greatly enhance NCWM's ability to serve the NTEP stakeholders. The NTEP Specialist also does type evaluations and VCAP audits, bringing in revenue to offset some of the additional cost of adding the position. Revenues in 2014 increased as a result of a higher than normal number of NTEP applications and some increase in membership.

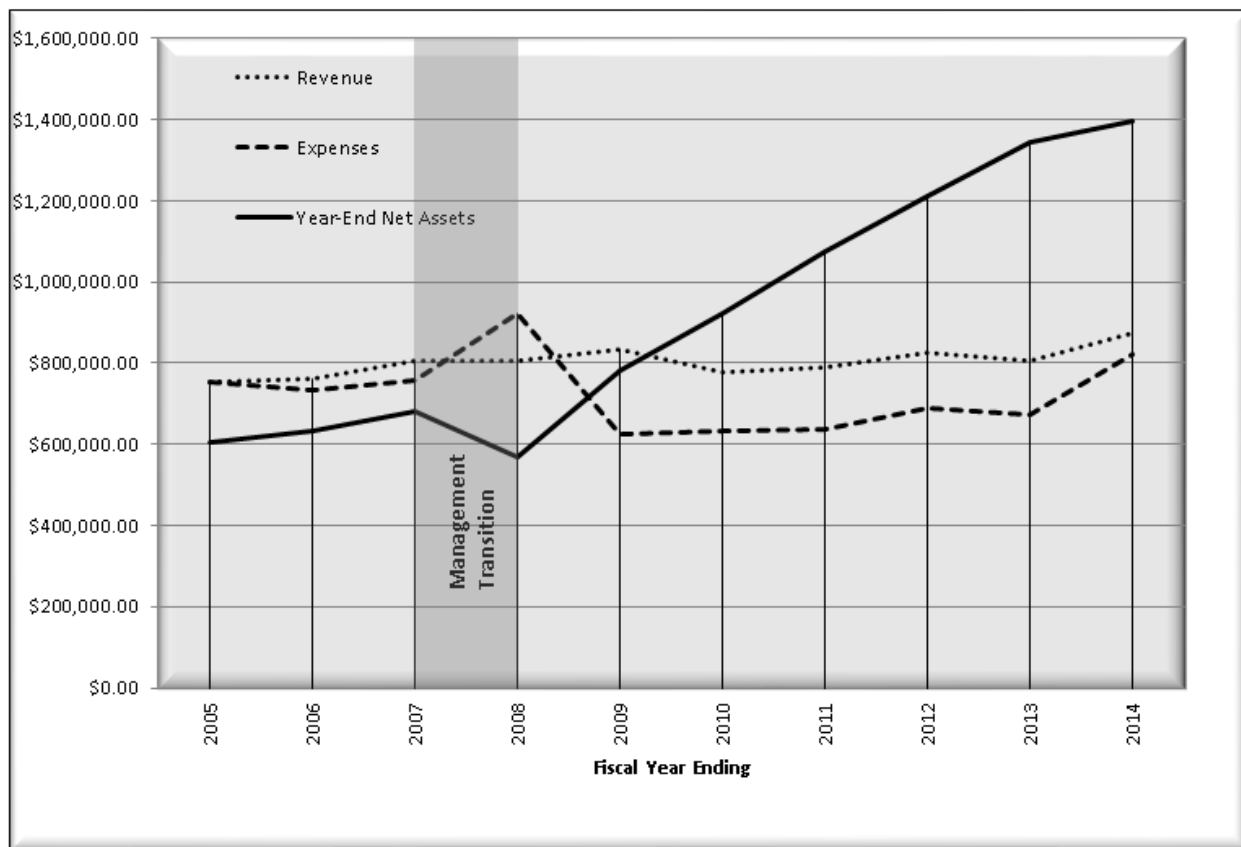

- Mr. Ronald Hayes, Missouri | Chairman
- Mr. Jerry Buendel, Washington | Chairman-Elect
- Mr. John Gaccione, Westchester County, New York | NTEP Committee Chair
- Mr. Mark Coyne, City of Brockton, Massachusetts | Treasurer
- Mr. Brett Gurney, Utah | Active Membership - Western
- Mr. Craig VanBuren, Michigan | Active Membership - Central
- Mr. Kenneth Ramsburg, Maryland | Active Membership - Southern
- Mr. James Cassidy, City of Cambridge, Massachusetts | Active Membership - Northeastern
- Mr. Chris Guay, Procter and Gamble | Associate Membership
- Mr. Steve Giguere, Maine | At-Large
- Mr. Chuck Corr, Archer Daniels Midland Co. | At-Large

- Ms. Carol Hockert, NIST, OWM | Executive Secretary
- Mr. Gilles Vinet, Measurement Canada | Board of Directors Advisor
- Mr. Jim Truex, NCWM | NTEP Administrator
- Mr. Don Onwiler, NCWM | Executive Director

**Board of Directors**

## Appendix A

### Report of the Activities of the International Organization of Legal Metrology (OIML) and Regional Legal Metrology Organizations

National Institute of Standards and Technology (NIST), Office of Weights and Measures (OWM)

#### INTRODUCTION

The OWM at NIST is responsible for coordinating the U.S. participation in OIML and other international legal metrology organizations. Learn more about OIML at [www.oiml.org](http://www.oiml.org) and about NIST, OWM at [www.nist.gov/owm](http://www.nist.gov/owm). Dr. Charles Ehrlich, Program Leader of the International Legal Metrology Program, can be contacted at (301) 975-4834 by fax at (301) 975-8091 or [charles.ehrlich@nist.gov](mailto:charles.ehrlich@nist.gov).

**Note:** OIML publications are available without cost at [www.oiml.org](http://www.oiml.org).

---

**Table A**  
**Table of Contents**

---

<b>Title of Content</b>	<b>Page A</b>
<b>INTRODUCTION .....</b>	<b>1</b>
<b>I. REPORT ON THE ACTIVITIES OF THE OIML TECHNICAL COMMITTEES .....</b>	<b>3</b>
TC 3/SC 5 Conformity Assessment (United States) .....	3
TC 5/SC 1 Environmental Conditions (Netherlands) .....	4
TC 5/SC 2 Software (Germany and BIML) .....	4
TC 6 Prepackaged Products (South Africa) .....	4
TC 8 Measurement of Quantities of Fluids (Japan) .....	4
TC 8/SC 1 Static Volume and Mass Measurement (Germany) .....	4
TC 8/SC 3 Dynamic Volume and Mass Measurement for Liquids Other Than Water (United States and .....	5
TC 8/SC 5 Water Meters (UK) .....	5
TC 8/SC 6 Measurement of Cryogenic Liquids (United States) .....	5
TC 8/SC 7 Gas Metering (Netherlands) .....	5
TC 9 Instruments for Measuring Mass (United States) .....	6
TC 9/SC 2 Automatic Weighing Instruments (United Kingdom) .....	6
TC 17/SC 1 Humidity (China and United States) .....	6
TC 17/SC 8 Quality Analysis of Agricultural Products (Australia) .....	6
OIML Mutual Acceptance Arrangement (MAA) .....	6
<b>II. REPORT ON THE 49TH CIML MEETING IN AUCKLAND, NEW ZEALAND, NOVEMBER 2014 .</b>	<b>6</b>
<b>III. FUTURE OIML MEETINGS.....</b>	<b>8</b>



**Table B**  
**Glossary of Acronyms and Terms**

<b>Acronym</b>	<b>Term</b>	<b>Acronym</b>	<b>Term</b>
ANSI	American National Standards Institute	ISO	International Standardization Organization
APEC	Asia-Pacific Economic Cooperation	IWG	International Work Group
APLMF	Asia-Pacific Legal Metrology Forum	LMWG	Legal Metrology Work Group
APMP	Asia-Pacific Metrology Program	MAA	Mutual Acceptance Agreement
B	Basic Publication	MTL	Manufacturers' Testing Laboratory
BIML	International Bureau of Legal Metrology	NIST	National Institute of Standards and Technology
BIPM	International Bureau of Weights and Measures	NTEP	National Type Evaluation Program
CD	Committee Draft <sup>1</sup>	OIML	International Organization of Legal Metrology
CIML	International Committee of Legal Metrology	OWM	Office of Weights and Measures
CTT	Conformity to Type	PG	Project Group
D	Document	R	Recommendation
DD	Draft Document <sup>2</sup>	SC	Technical Subcommittee
DoMC	Declaration of Mutual Confidence	SIM	Inter-American Metrology System
DR	Draft Recommendation <sup>2</sup>	TC	Technical Committee
DV	Draft Vocabulary <sup>3</sup>	USNWG	U.S. National Work Group
GA	General Assembly	VIM	International Vocabulary of Metrology
IEC	International Electrotechnical Commission	VIML	International Vocabulary of Legal Metrology
IQ Mark	International Quantity Mark	WD	Working Draft <sup>3</sup>
<p><sup>1</sup> CD: a draft at the stage of development within a Technical Committee, Subcommittee or Project Group; in this document, successive drafts are numbered 1 CD, 2 CD, etc.</p> <p><sup>2</sup> DD, DR, and DV: a draft document approved at the level of the technical committee, subcommittee or Project Group concerned and sent to BIML for approval by CIML.</p> <p><sup>3</sup>WD: precedes the development of a CD; in this document, successive drafts are number 1 WD, 2 WD, etc.</p>			

---

**Details of All Items  
(In order by Reference Key)**

---

## I. Report on the Activities of the OIML Technical Committees

This section reports on recent activities and the status of work in the OIML Technical Committees (TCs), Technical Subcommittees (SCs), and Project Groups (PGs) of specific interest to members of the National Conference on Weights and Measures (NCWM). Schedules of future activities of the TC/SC Secretariats, PG Conveners, the U.S. National Work Groups (USNWGs), and the International Work Groups (IWGs) and Project Groups of the TCs and SCs are also included.

### TC 3/SC 5 Conformity Assessment (United States)

The OIML Basic Publications B 3:2011 *Certificate System* and B 10:2012 *Mutual Acceptance Arrangement* (MAA) are the core documents underpinning the OIML Certificate System. An amendment to B 10 was approved by the CIML that allows for the voluntary use of test data from manufacturer's test laboratories (MTLs) under specially supervised conditions. (NCWM has adopted the position that it will not accept test data under the MAA that was obtained from MTLs.)

An MAA workshop was held in conjunction with the 2013 CIML Meeting (in Vietnam) to gather experiences of the various MAA stakeholders in the MAA. Based on the outcome of this workshop and MAA discussions at the 2013 CIML Meeting, OIML has established an *Ad-Hoc* Working Group (AHWG) consisting of interested CIML members, Committee on Participation Review (CPR) members, and representatives of manufacturers' associations. This working group was tasked with reviewing the structure, rules, and procedures governing the operation of the MAA (and the role of Utilizing Participants), with a view to increasing the efficiency of the operation of the MAA, and, if necessary, amending their internal (MAA) documents and suggesting to TC 3/SC 5 appropriate amendments to OIML Publication B 10. This AHWG is chaired by the CIML first Vice-President Dr. Roman Schwartz of PTB (Germany), and held its first meeting on March 20 - 21, 2014, at NIST. Mr. Darrell Flocken from NCWM attended, as did Mr. Rob Upright, President of the U.S. Scale Manufacturer's Association (SMA), and Mr. Dmitri Karimov, Chair of the U.S. Meter Manufacturer's Association (MMA). Three Task Groups were established that looked into 1) improving the international awareness and use of the OIML MAA; 2) developing a more robust model for operation of the CPR; and 3) evaluating the impact that termination of the Basic System for categories already covered by the MAA (currently these are load cells, NAWIs and water meters) would have on all stakeholders.

At the CIML Meeting in November 2014, in Auckland, New Zealand, the Committee encouraged the AHWG, and its three Task Groups, to present concrete proposals at the 2015 CIML meeting and instructed the BIML to provide all necessary support to help the AHWG achieve its objectives. The Committee also requested that CIML Members inform the BIML about their experience and knowledge as to whether or not OIML certificates (Basic or MAA) and OIML Test Reports are accepted in their countries as the basis for national or regional type approval, and the reasons in cases where they are either not accepted, or not completely accepted. Mr. Jim Truex, NTEP Administrator, provided this information for the United States.

A sub-group of the AHWG met in March 2015, to review a proposal put forward by the second Task Group that could significantly change the way that the OIML Certificate System is structured, managed and operated. This proposal includes the creation of an OIML Certificate System (called OIML-CS), which would be managed by a Management Committee instead of by the BIML. Advisory Committees to the Management Committee are also envisioned. A full AHWG meeting will be held in early June 2015, to finalize a proposal that will be put forward to the CIML at its meeting in Arachon, France, in October 2015. Until the new OIML-CS is approved by the CIML, the current Basic and MAA systems will continue and will be supported by the BIML.

A new OIML document entitled *The Role of Measurement Uncertainty in Conformity Assessment Decisions in Legal Metrology* has passed its 2 CD vote. A preliminary ballot of this document was distributed for CIML vote and comment in July 2015. For a copy of this document, please contact Dr. Ehrlich at (301) 975-4834 or charles.ehrlich@nist.gov. Please also see the MAA section in the National Type Evaluation Program (NTEP) Committee Report of this publication for more details on the activities of TC 3/SC 5. Please contact Dr. Ehrlich for more information on the activities of this Subcommittee.

#### **TC 5/SC 1 Environmental Conditions (Netherlands)**

OIML D 11 *General requirements for measuring instruments - Environmental conditions* has been published. This is a very important document in the OIML system and is used by all of the OIML TCs as a general reference for technical and testing requirements on all measuring instruments. Highlights of this recent revision cycle include: expanding the terminology section, updating several testing sections to reflect the latest International Electrotechnical Commission (IEC) reference standards, and including a new environmental class (“E3”) for a non-mains local source of electrical power supply. Please contact Mr. Ralph Richter at (301) 975-3997 or [ralph.richter@nist.gov](mailto:ralph.richter@nist.gov), if you would like additional information on TC 5/SC 1 or OIML D 11.

#### **TC 5/SC 2 Software (Germany and BIML)**

The OIML D 31 *General Requirements for Software-controlled Measuring Instruments* has been published and now serves as guidance for software requirements in International Recommendations by OIML TCs. The United States participated in the technical work on this document and submitted votes and comments on several drafts of the document. A new project on software verification was approved by CIML, and the United States is waiting for the first draft of this document. Please contact Dr. Ambler Thompson at (301) 975-2333 or [ambler@nist.gov](mailto:ambler@nist.gov) if you would like to discuss OIML software efforts.

#### **TC 6 Prepackaged Products (South Africa)**

The first draft of a new project *Guidance for defining the system requirements for a certification system for prepackages* was discussed at a TC 6 meeting in Seoul, South Korea, in September 2014. This guideline is being developed to assist countries in establishing reciprocal agreements to accept the test results on prepackaged goods. It is expected that the 2CD of this guidance document will be distributed in the second half of 2015.

A revision of OIML Recommendation R 87 *Quantity of Product in Prepackages* (the OIML equivalent to NIST Handbook 133, *Checking the Net Contents of Packaged Goods*) includes a comprehensive overhaul of the statistical requirements and sampling plans (the revisions were prepared by Blaza Toman of NIST’s Statistical Engineering Division) to correct errors discovered by a statistician from Asia a few years ago. The United States and several other countries were successful in opposing efforts by several European Union countries to add drained weight test procedures and packaging requirements utilized in that region to the new edition of R 87. Those procedures were rejected primarily because they failed to recognize drained weight test methods that have been in use around the world for decades and which have been adopted by Codex Alimentarius. The United States voted “yes” and submitted comments on the 3 CD of R 87 in October 2014. CIML vote and comments on the preliminary ballot of R 87 will close in September 2015.

The United States plans to vote “yes” on the CIML Preliminary Ballot of OIML R 79 *Labeling Requirements for Prepackaged Products* in June 2015. It is expected that R 79 will receive final CIML approval in October 2015. For more information on the activities of this Committee, and to participate in the U.S. review of these documents, please contact Mr. Ken Butcher at (301) 975-4859 or [kbutcher@nist.gov](mailto:kbutcher@nist.gov).

#### **TC 8 Measurement of Quantities of Fluids (Japan)**

The Japanese Secretariat for TC 8 distributed a questionnaire in 2014 concerning several projects in TC 8. Based on responses received on the questionnaire, Japan decided to cancel a project to combine and revise R 40, R 41 and R 43 into a single standard entitled *Standard volumetric measures*. Japan also decided to delay the project to revise R 63, *Petroleum Measurement Tables* (1994) until the corresponding ISO standard is next revised. The Secretariat plans to start the revision of R 119, *Pipe Provers for Testing of Measuring Systems for Liquids Other Than Water* (1996) – this document is important for other OIML recommendations involving liquid measurement. Please contact Mr. Ralph Richter at (301) 975-3997 or [ralph.richter@nist.gov](mailto:ralph.richter@nist.gov), if you would like copies of any of these documents or to participate in the project to revise R 119.

#### **TC 8/SC 1 Static Volume and Mass Measurement (Germany)**

The United States chairs the Project Group that is drafting new sections of OIML R 71, *Fixed Storage Tanks* and R 85, *Automatic Level Gages for Measuring the Level of Liquid in Fixed Storage Tanks* to add specific requirements for specialized tanks. A CD of OIML R 80-2, *Road and Rail Tankers, Test Methods* has been developed by Germany. The Secretariat has also initiated the effort of revising OIML R 95, *Ships’ Tanks*. A meeting to discuss all of these TC 8/SC 1 projects was held in Germany in December 2014. Please contact Mr. Ralph Richter at (301) 975-3997 or [ralph.richter@nist.gov](mailto:ralph.richter@nist.gov), if you would like copies of the documents or to participate in any of these projects.

**TC 8/SC 3 Dynamic Volume and Mass Measurement for Liquids Other Than Water (United States and Germany)**

New annexes for measuring systems for foaming potable liquids, for pipelines, and for aircraft refueling have been added to OIML R 117-2, *Dynamic Measuring Systems for Liquids Other Than Water, Part 2, Test Methods*. The 2 CD of R 117-2 was approved by the Project Group in March 2014 with over 300 comments. The 1 CD of R 117-3 *Part 3, Test Report Format* was distributed in March 2014. A meeting of the R 117 International Project Group was held in April 2014 in Chicago, Illinois. International comments on the 2 CD of R 117-2 and the 1 CD of R 117-3 were discussed and new committee drafts of both documents were created and approved at the meeting. Representatives of major manufacturers of these systems and liaison organizations actively participated in the meeting. These technical experts provided a depth of experience and technical expertise that proved highly valuable during the meeting.

Both R 117-2 and R 117-3 passed their CIML preliminary ballots with 100 % consensus in July 2014; they also received final CIML approval with 100 % consensus in November 2014. Both documents were published in April 2015. The CIML also approved a new project for an “immediate revision” of all three parts of R 117. This new project will fully harmonize all three parts and add new annexes to R 117 for several complete measuring systems, including: a) measuring systems for the unloading of ships' tanks and for rail and road tankers using an intermediate tank; b) measuring systems for liquefied gases under pressure (other than LPG dispensers); c) measuring systems for bunker fuel; and d) measuring systems for liquefied natural gas (LNG). If you have any questions or would like to participate in the next phases of this project, please contact Mr. Ralph Richter at (301) 975-3997 or [ralph.richter@nist.gov](mailto:ralph.richter@nist.gov).

**TC 8/SC 5 Water Meters (UK)**

OIML, the International Standardization Organization (ISO), and the European Committee for Standardization (CEN) worked together to harmonize requirements for water meters using OIML R 49 *Water Meters Intended for the Metering of Cold Potable Water and Hot Water Parts 1, 2, and 3* as the base document. The American Water Works Association Committee on Water Meters assisted in these efforts. This new revision of R 49 (which is now harmonized with the water meter standards from ISO and CEN) was published in May 2014. Please contact Mr. Ralph Richter at (301) 975-3997 or [ralph.richter@nist.gov](mailto:ralph.richter@nist.gov), if you would like additional information on these documents.

**TC 8/SC 6 Measurement of Cryogenic Liquids (United States)**

The Secretariat for R 81, *Dynamic Measuring Devices and Systems for Cryogenic Liquids* has distributed a first working draft (1WD) of R 81 to TC 8/SC 6 members and the USNWG for their review and comment. Nine members of the R 81 project group submitted comments on Parts 1 and 2 of R 81. A compilation of those comments will be distributed in late-2015, and distribution of a first committee draft incorporating these comments is also planned for late-2015. To obtain more information or to participate in this project, please contact Ms. Juana Williams at (301) 975-3989 or [juana.williams@nist.gov](mailto:juana.williams@nist.gov).

**TC 8/SC 7 Gas Metering (Netherlands)**

All three parts of OIML R 137, *Gas Meters* have been published. Extensive United States comments on the 1 CD, the 2 CD, and the DR were developed in cooperation with the measurement committees of the American Gas Association. CIML voting on the preliminary ballot of R 137-3 *Part 3: Report Format for Type Evaluation* closed in March 2014, and the document received final CIML approval in November 2014. The OIML R 137 document is especially important to the U.S. interests because the American National Standards Institute (ANSI) B 109 committee on gas measurement is using the published R 137 to create a new performance-based standard for gas meters in the United States. Please contact Mr. Ralph Richter at (301) 975-3997 or [ralph.richter@nist.gov](mailto:ralph.richter@nist.gov), if you would like to participate in these efforts or if you would like to obtain a copy of any of these gas measurement documents.

The CIML preliminary ballot on OIML R 139, *Compressed gaseous fuel measuring systems for vehicles*, passed in March 2014. This standard is important to U.S. stakeholders, especially in the effort to maximize harmonization between domestic and international legal metrology requirements used for the delivery of alternative fuels such as hydrogen gas and compressed natural gas (CNG). The United States voted “yes” and submitted comments on the preliminary ballot. R 139 received final CIML approval in November 2014, and was published in February 2015. To obtain more information on this effort, please contact Ms. Juana Williams at (301) 975-3989 or [juana.williams@nist.gov](mailto:juana.williams@nist.gov).

### **TC 9 Instruments for Measuring Mass (United States)**

The United States distributed the 3 CD of R 60, *Metrological Regulation for Load Cells* Parts 1 and 2 (Metrological and technical requirements and Metrological controls and performance tests) in August 2014 for comments and voting. The Project Group decided that R 60 needs further development, and a 4 CD is being drafted; it is expected to be circulated in late-2015. A working draft of R 60-3 is also planned to be circulated late-2015. For more information on TC 9 activities, please contact Mr. John Barton at (301) 975-4002 or john.barton@nist.gov.

### **TC 9/SC 2 Automatic Weighing Instruments (United Kingdom)**

All three parts of OIML R 50, *Continuous Totalizing Automatic Weighing Instruments* (Belt Weighers), received final CIML approval in November 2014, and R 50 was published in March 2015. To receive copies of these documents or to obtain more information on the work of this Subcommittee, please contact Mr. John Barton at (301) 975-4002 or john.barton@nist.gov.

The TC 9/SC 2 Secretariat distributed a questionnaire concerning a possible project to revise OIML R 51, *Automatic catch-weighing instruments*, which was last revised in 2006. The proposed international effort to revise R 51 was also announced by the NCWM. Please contact Mr. Rick Harshman at (301) 975-8107 or richard.harshman@nist.gov if you are interested in the project to revise this document.

### **TC 17/SC 1 Humidity (China and United States)**

The 7 CD of OIML R 59, *Moisture Meters for Cereal Grains and Oilseeds*, was distributed for voting in December 2014. Votes and comments were requested by March 11, 2015. Voting was conducted using the new OIML on-line voting for project groups. OIML officially closed the online voting on April 29, 2015. A total of seven “yes” votes and one “no” vote was provided by the TC 17/SC 1 project group’s participating members. The 7 CD was approved. Comments received on the 7 CD will be considered, and the document will be forwarded to OIML as a DR for final voting. Please contact Ms. G. Diane Lee at (301) 975-4405 or diane.lee@nist.gov if you would like to participate in this work.

### **TC 17/SC 8 Quality Analysis of Agricultural Products (Australia)**

The 5 CD of a draft document *Measuring Instruments for Protein Determination in Grains* was circulated for vote in 2014. The United States voted “yes” on the 5 CD of this draft document in December 2014. A DR is expected in 2015. Please contact Ms. G. Diane Lee at (301) 975-4405 or diane.lee@nist.gov, if you would like to participate in this work.

### **OIML Mutual Acceptance Arrangement (MAA)**

The report on the OIML MAA can be found in the TC 3/SC 5 report above and in the NTEP section of this document. For further information on the MAA and its implementation, please contact Dr. Charles Ehrlich at (301) 975-4834 or email charles.ehrlich@nist.gov.

## **II. REPORT ON THE 49TH CIML MEETING IN AUCKLAND, NEW ZEALAND, november 2014**

Mr. Peter Mason, CIML member from the United Kingdom and President of the CIML, opened the meeting and gave the President’s Report.

Mr. Stephen Patoray, who has been serving as BIML Director since January 2011, provided several reports on financial and administrative matters at the BIML, including improvements that have been implemented since his arrival at the BIML. Mr. Patoray also discussed upgrades to the OIML website and significant improvements to the BIML headquarters building in Paris.

Based on a proposal by Mr. Mason and after a lengthy discussion by the representatives of the CIML member states, the CIML decided it expects to renew the appointment of the BIML Director for a fixed term of up to five years at its meeting in 2015. As part of this decision, the CIML also decided not to appoint a selection committee to attempt to find a new BIML Director.

The CIML welcomed Cameroon as a re-instated Member State and welcomed Azerbaijan as a new Corresponding Member.

The Committee noted an oral report given by the BIML on its activities in liaison with other international organizations aimed at developing countries, in particular regarding the organization of an AFRIMETS Legal Metrology School in Tunis in October 2014. The Committee also established an advisory group to carry out wide consultation, to seek suggestions and to build up links with other bodies with an interest in promoting the economic development of countries and economies with emerging metrology systems.

After some discussion on the matter, the CIML decided to disband 12 existing Project Groups either because they did not have the required number of participating Member States (at least six) or because no Member State volunteered to assume the convenership of the Project Group.

The Committee approved the following draft publications:

- Amendment to R 35-1: *Material measures for length for general use – Part 1: Metrological and technical requirements;*
- Revision of R 50-1: *Continuous totalizing automatic weighing instruments (belt weighers) – Part 1: Metrological and technical requirements;*
- Revision of R 50-2: *Continuous totalizing automatic weighing instruments (belt weighers) – Part 2: Test procedures;*
- R 50-3: *Continuous totalizing automatic weighing instruments (belt weighers) – Part 3: Test report format;*
- R 117-2: *Dynamic measuring systems for liquids other than water – Part 2: Metrological controls and performance tests;*
- R 117-3: *Dynamic measuring systems for liquids other than water – Part 3: Test report format;*
- Revision of R 139-1: *Compressed gaseous fuels measuring systems for vehicles – Part 1: Metrological and technical requirements;* and
- Revision of R 139-2: *Compressed gaseous fuels measuring systems for vehicles – Part 2: Metrological controls and performance tests.*

The Committee also approved a new project in TC 8/SC 3 for the “immediate revision” of all three parts of R 117, *Dynamic measuring systems for liquids other than water* – and also approved a new project in TC 8/SC 7 for the revision of all parts of R 140, *Measuring systems for gaseous fuels*.

The Committee noted a report given by the MAA AHWG chair and CIML First Vice-President, Dr. Roman Schwartz of PTB in Germany. The AHWG was created by the CIML in 2013 to: raise awareness of the MAA, review the CPRs and their structure, review the rules and procedures governing the operation of the MAA, and work to increase the efficiency of the operation of the MAA. The Committee encouraged the AHWG, and its three sub-groups, to present concrete proposals at the 2015 CIML meeting and instructed the BIML to provide all necessary support to help the AHWG achieve its objectives. The Committee also requested that CIML Members inform the BIML about their experience and knowledge as to whether or not OIML certificates (Basic or MAA) and OIML Test Reports are accepted in their countries as the basis for national or regional type approval, and the reasons in cases where they are either not accepted, or not completely accepted. NCWM will be providing input on this. (See also the TC 3/SC 5 section of this OIML report.)

The Committee congratulated this year’s recipients of an OIML Medal:

- Mr. Stuart Carstens, former CIML Vice-President and member of the Presidential Council;
- Dr. Grahame Harvey, former CIML Vice-President and former member of the Presidential Council; and
- Mrs. Veronika Martens, President of the Legal Metrology Group of CECIP.

### III. Future OIML Meetings

The next CIML Meeting will be held during the week of October 19, 2015, in Arcachon, France. A seminar on “Legal Metrology and Social Economic Development” is being planned in conjunction with the 2015 CIML meeting. The next OIML Conference will be held in 2016; the venue and dates for this meeting have not yet been announced.

### IV. Regional Legal Metrology Organizations

A meeting of the Inter-American Metrology System (SIM) General Assembly is organized annually and is the event where delegates from National Metrology Institutes of the Americas meet to discuss important issues. This past year, the SIM General Assembly was held in November 2014 in Bogotá, Columbia. Mr. José Dajes Castro, from INDECOPI in Lima, Peru, serves as the SIM President. The Legal Metrology Working Group is chaired by Mr. Emilio Löbbe from INTI/Argentina. The organization is working to build capacity in legal metrology for SIM member countries. In April 2014, INTI and INMETRO held a three-day Workshop in Brazil on “Hardware and Software Security in Legal Metrology.” Please contact Mr. Ralph Richter at (301) 975-3997 or ralph.richter@nist.gov for more information on SIM.

The 21<sup>st</sup> Meeting of the Asia-Pacific Legal Metrology Forum (APLMF) was held November 10 - 12, 2014, in Wellington, New Zealand. The People’s Republic of China holds the Presidency and Secretariat of APLMF. Mr. Changcheng, APLMF President and Vice Minister of AQSIQ, chaired the meeting. During the opening comments at the APLMF Meeting, it was announced that New Zealand planned to assume the APLMF Secretariat in 2015.

The main objectives of APLMF are to coordinate regional training courses in legal metrology and to provide a forum for exchange of information among legal metrology authorities. APLMF activities are facilitated through its seven WGs. The most active WG is the WG on Training Coordination, chaired by Australia. In the past year, APLMF held training on “Traceability in Rice Moisture Measurement” in Thailand and “Non-automatic Weighing Instruments” in Indonesia.

The WG on Training Coordination reported on the results of a 2013 survey of APLMF member economies that requested information on the benefits of APLMF training that was conducted in the period 2005 to 2013. The results clearly indicated that the more than 20 courses conducted by APLMF in that eight-year time period were highly valued by the member economies, promoted harmonization in the Asia-Pacific region, and frequently led to revised/improved legislation and regulations in the member economies.

A significant joint project entitled “Metrology Enabling Developing Economies in Asia” (MEDEA) has been launched by APLMF, the Asia Pacific Metrology Programme (APMP) and the Physikalisch-Technische Bundesanstalt (PTB). This four-year project is being managed by PTB and is primarily funded by Germany. The project aims to foster and further develop the capabilities of the APLMF and the Asia-Pacific Metrology Program (APMP) to support developing economies in the Asia-Pacific region, to promote metrology systems within developing economies, and to strengthen the metrology systems/infrastructure within developing economies. Dr. Anna Cypionka is the PTB MEDEA Project Coordinator. A status report on the first year’s activities of the MEDEA Project was provided at the APLMF meeting. The main first-year accomplishments were to establish a Coordination Committee and to survey APLMF developing economies about their legal and scientific metrology capabilities and needs. Several training courses are planned through the MEDEA Project for the years 2015 to 2017.

The United States was represented at the APLMF meeting in Wellington, New Zealand, by Dr. Charles Ehrlich and Mr. Ralph Richter. Dr. Ehrlich serves as the Chair of the APLMF WG on Mutual Recognition Arrangements and gave a report and update on the OIML MAA. Mr. Richter presented the United States Country Report.

The United States will host the next APLMF meeting on October 28 - 30, 2015, in Hawaii. Please contact Mr. Ralph Richter at (301) 975-3997 or ralph.richter@nist.gov for more information on APLMF and the 2015 APLMF Annual Meeting.

**Appendix B**

**Associate Membership Committee (AMC)  
Agenda and Final Interim Meeting Minutes**

Bill Calloway, Chair  
Crompco

---

**Table A  
Table of Contents**

---

<b>Title of Content</b>	<b>Page B</b>
<b>AGENDA</b> .....	<b>2</b>
<b>AMC DRAFT MEETING MINUTES</b> .....	<b>3</b>
Call to Order .....	3
Meeting Minutes.....	3
Financial Condition .....	3
Board of Directors Report .....	3
Professional Development Committee (PDC) Report .....	4
Laws and Regulations (L&R) Committee Report .....	4
AMC Fund Disbursement Report.....	4
Filling Vacant Positions.....	5
Old Business .....	5
New Business .....	5
Adjournment .....	5
Individuals in Attendance .....	5



---

**Details of All Items**  
*(In order by Reference Key)*

---

**AGENDA**

- I. Call to Order
  - II. Approval of Meeting Minutes
  - III. Financial Condition
  - IV. NCWM Industry Representative Reports
    - (a) Board of Directors Report
    - (b) Professional Development Committee Report
    - (c) Laws and Regulations Committee Report
  - V. AMC Fund Disbursement Requests
  - VI. Filling Vacant Positions
  - VII. Old Business
  - VIII. New Business
  - IX. Adjournment
-

**Report of the  
Associate Membership Committee (AMC)  
Final Interim Meeting Minutes**

January 20, 2015  
Daytona, Florida

**I. Call to Order**

The meeting was called to order at approximately 5:15 p.m. by the AMC Chairman, Mr. Bill Calloway. There was a small delay in starting the meeting due to a schedule conflict with the meeting room.

**II. Meeting Minutes**

The minutes from the previous AMC meeting were unanimously approved.

**III. Financial Condition**

- The financial report review indicated that the AMC account has a balance of \$34,570.31 as of January 20, 2015.
- Mr. Bob Murnane inquired about all outstanding disbursements of which it was determined that there were approximately \$15,170 of outstanding disbursements (funds that have been approved for training but the training has not occurred).
- It was determined that there was approximately \$5,295 remaining available for Scholarship Applications.
- A discussion regarding the approval of AMC funds for training concluded that the AMC will have to be more selective in approving funds for training as the account balance diminishes.
- There was a consensus that the AMC should approve funds for training that will benefit larger groups of weights and measures officials.
- The AMC should consider collecting the Scholarship Applications and wait until our next meeting to evaluate which applications benefit the most people prior to approving them. By waiting until the meeting, it will enable the AMC to evaluate multiple applications prior to approval.

**IV. Board of Directors Report**

Mr. Guay, the AMC representative on NCWM Board of Directors (BOD) gave a report regarding BOD activities:

- The BOD wants to make the AMC Scholarship Application more visible to the various Directors. This can be done by relocating the application on the website.
- There is an Asia Pacific Metrology Forum in which 20 countries will participate in November 2015. Dr. Chuck Ehrlich, NIST, OWM, was in attendance and wanted to discuss the Forum with the AMC. The APMF discussion was added to the "New Business" category of the meeting.
- The BOD wanted input from the AMC regarding the schedule of NCWM meetings. The BOD is considering starting NCWM meetings on Monday instead of the weekends in order to help facilitate more attendance. The AMC members had various opinions. It was decided to discuss in more detail during the "New Business" section of the AMC meeting.

- The NCWM 100<sup>th</sup> Annual Meeting anniversary year is this July's Annual Meeting. The BOD is planning the event with a speaker. The BOD inquired if the AMC will be contributing funding to the event – Mr. N. David Smith travel support? Creating pins? Other give-aways?
- Mr. Steve Langford made a motion to contribute \$5,000 to the Conference in support of the 100<sup>th</sup> Annual Meeting anniversary. It was determined that the vote be tabled until later in the meeting "New Business," because there was still additional proposals to be reviewed by Dr. Ehrlich regarding the Asia-Pacific Legal Metrology Forum (APLMF).
- NIST Administrator Workshop in the spring (for new Weights and Measures Administrators – about 30 current state administrators have never had this training) covering NIST Handbook 155, "Weights and Measures Program Requirements: A Handbook for the Weights and Measures Administrator."
- NIST, OWM Budget tight but doable.
- Traceability assessment in United States showed 45 states are in excellent shape.
- The AMC guideline for assessing funding requests for training updated.
- The BOD is starting to look at Policies and By-laws to address and streamline procedures for introducing items and voting procedures.
- The BOD plans to establish a new section for standards and documents, which are not part of the NIST Handbooks.
- The AMC funds to support 100<sup>th</sup> Annual Meeting.
- The APLMF Meeting planned in autumn (likely November) 2015 in California or Hawaii.
- A review of the Regional Association meetings was conducted along with their locations.

**Central Weights and Measures Association (CWMA):**

- The 2015 CWMA meeting will be held at the Crown Plaza North in Columbus, Ohio (May 18 to 22).
- Mr. Mike Miller is a new Weights and Measures Director in Indiana.

**Northeastern Weights and Measures Association (NEWMA):**

- May 4 to May 8 – Saratoga Springs, New York – NEWMA Chair is Cheryl from New Hampshire, Vice Chair is Mark from Vermont. 2016 NEW meeting in Vermont is currently planned.
- Vermont adopting the Uniform Pricing Regulation in NIST, Handbook 130, "Uniform Laws and Regulations in the Areas of Legal Metrology and Engine Fuel Quality."
- New York is starting motor oil testing. An issue had been identified in New Jersey.

**Southern Weights and Measures Association (SWMA):**

- Mr. Dale Saunders stepped down as the Director of Weights and Measures in Virginia.
- The Southern Meeting this year is in Biloxi, Mississippi, October 24 to 28.

**Western Weights and Measures Association (WWMA):**

- Utah focused on training, and extended training to other states:
  - Eight Western states present at retail motor fuel dispensers training in September;
  - Nine Western states present at small scale training in November;
  - February, hosting Price Verification Training;
  - March, hosting Vehicle Scale Training; and

- Looking at Audit Trails Training.
- WWMA Conference in Boise ID September 27 to October 1, 2015.
- 2016 WWMA Conference still being planned for Hawaii.
- New Mexico establishing new regulations for Compressed Natural Gas (CNG).
- Privatization of the Montana Program has been dropped from consideration.
- Arizona citing Uber for various violations for local regulations.
- Colorado required to inspect marihuana scales used for commercial and non-commercial purposes.
- Using gas equivalent gallons and diesel gallon equivalent (DGE) in Colorado.
- Mr. Steve Cook retiring from California on Feb 2, 2015, (been back from NIST since 2011).
- California using gasoline gallon equivalent (GGE) and DGE for fuel.

#### **Professional Development Committee (PDC) Report**

Mr Shipman, the AMC representative on the PDC, gave a report about the Committee's activities.

- A lot of discussion about getting more states on board with the certification program. We are tracking participation by state and region.
- There has been some discussion about bringing service organizations into the program.
- A Gateway program is being discussed. Techs will need an appropriate level of test that enables them to get into the field and gain experience necessary to take the more advanced certifications.
- Mr. Don Onwiler has challenged to the Committee to think about taking the program to the next level. Things to be considered are test proctoring and program accreditation.

#### **Laws and Regulations (L&R) Committee Report**

Mr. Grabski, the AMC representative on the L&R Committee gave a report about the Committee's activities.

- Provided information on what would be Voting, Developmental, Informational, or Withdrawn.
- Updated the group about the joint meeting with S&T Committee.
- Reported that Liquid Nitrogen Gas (LNG) could be sold by DGE, DLE, GGE, GLE, or mass.

#### **V. AMC Fund Disbursement Report**

Mr. Calloway, the AMC Chairman presented the following training fund requests

- New York State Weights and Measures Association Training School requested AMC Funds (\$3,000). Funds to be used for the conference room at the hotel for the training seminar. Unanimously Approved.
- Northwest Vehicle Scale Inspection Class (Alaska, Washington, Utah) requested AMC Funds (\$4,000). It is anticipated there will be 25 participants. Unanimously Approved
- SWMA requested AMC funds to conduct a presentation of the NCWM Training Manual during the SWMA meeting (\$2500). Funds approved contingent on the AMC only paying for travel, lodging, and meals for only two nights and excluding registration fees to the SWMA meeting in Biloxi, Mississippi.

### **Discussion Regarding Applications for AMC Funds**

- It was determined that the website Scholarship Application and the downloadable Scholarship Application are different. The two applications will be amended to require the same information.
- Mr. Don Onwiler is going to review the applications prior to submission to the AMC. The AMC voiced a concern regarding the thoroughness of the applications and in the future will require the applications to include more specific information for what the AMC funds will be used.
- It was agreed that the AMC will increase the scrutiny of Scholarship Application and change the approval process to the following:
  - The online application and the downloadable application will be amended so they are identical;
  - Mr. Don Onwiler will review the applications prior to submission to the AMC;
  - The AMC will require the applications to be thoroughly completed to specifically include what the funds will be paying for as well as how many students will benefit from the training; and
  - AMC will wait until the meetings to vote on the applications.

### **VI. Filling Vacant Positions**

There were no open vacant positions to discuss.

### **VII. Old Business**

- In past meetings, the AMC discussed providing NCWM pins for the 100<sup>th</sup> Annual Meeting Conference. There was various debate regarding the pins; however, the group decided the Conference may prefer funding instead of pins.

### **VIII. New Business**

- Dr. Chuck Ehrlich presented an overview of the Asian Pacific Metrology Forum (APMF) that is schedule for November 2015. The location is to be determined, and the forum is open to businesses as well as the regulatory agencies.
  - The goal of the forum is to exchange ideas among the participants. There are over 20 countries that will be in attendance all of whom are interested in the United States organization of metrology and commerce.
  - The event will be special and as such the APMF will be submitting an application to AMC to host an event during the forum. The APMF will be requesting between \$3,000 to \$5,000 for the event.
- A vote on Mr. Steve Langford's motion to give the NCWM \$5,000 for the 100<sup>th</sup> Annual Meeting year anniversary was conducted after some discussion on the motion. The discussion included various opinions regarding the use of AMC funds. The majority of the AMC concluded that AMC funds were to be used for training purposes. A vote was taken and four were in favor of the donation and eight were against the donation. The motion failed.
- Mr. Bob Murnane suggested that the AMC meetings should be moved to the conclusion of the Open Hearings during the NCWM.

**IX. Adjournment**

With no further new business Chair Callaway adjourned the meeting at 6:55 p.m.

Respectfully submitted by,  
Mr. Richard Shipman,  
Secretary/Treasurer, AMC

**X. Individuals in Attendance**

Mr. Richard Shipman, Rice Lake Weighing Systems  
Mr. Chris Guay, Procter & Gamble  
Mr. Ed Luthy, Schenick Process, LLC  
Mr. Steve Grabski, Walmart  
Ms. Ann Boeckman, Craft Foods  
Mr. Paul Lewis Sr., Rice Lake Weighing Systems  
Mr. Eric Golden, Cardinal Scale  
Mr. Steven Langford, Cardinal Scale  
Mr. Don Onwiler, NCWM  
Mr. Krister Hard Af Segterstad, IKEA N.A. Services, LLC  
Mr. Bob Murname, Seraphin  
Mr. Louis Straub, Fairbanks Scales  
Dr. Chuck Ehrlich, NIST, OWM  
Mr. Rob Upright, Vishay Transducers  
Mr. Russel Vires, Mettler-Toledo  
Mr. David Calix, NCR  
Mr. Bill Calloway, Crompco

**Associate Membership Committee**

THIS PAGE INTENTIONALLY LEFT BLANK

## Report of the Laws and Regulations (L&R) Committee

Tim Lloyd, Committee Chair  
Montana

### 200 INTRODUCTION

This is the report of the Laws and Regulations (L&R) Committee (hereinafter referred to as the “Committee”) for the 100<sup>th</sup> Annual Meeting of the National Conference on Weights and Measures (NCWM). This report is based on the Interim Report offered in the NCWM Publication 16, “Committee Reports,” testimony at public hearings, comments received from the regional weights and measures associations and other parties, the addendum sheets issued at the Annual Meeting, and actions taken by the membership at the voting session of the Annual Meeting. The voting items shown below were adopted as presented when this report was approved. This report contains those recommendations to amend the National Institute of Standards and Technology (NIST) Handbook 130 (2015), “Uniform Laws and Regulations in the Areas of Legal Metrology and Engine Fuel Quality,” and the NIST Handbook 133, “Checking the Net Contents of Packaged Goods (2015).”

Table A identifies the agenda and appendix items by reference key, title of item, page number, and the appendices by appendix designations. The acronyms for organizations and technical terms used throughout the agenda are identified in Table B. The first three digits of the Reference Key Numbers of the items are assigned from the Subject Series List. The status of each item contained in the report is designated as one of the following: **(D) Developing Item:** the Committee determined the item has merit; however, the item was returned to the submitter or other designated party for further development before any action can be taken at the national level; **(I) Informational Item:** the item is under consideration by the Committee but not proposed for Voting; **(V) Voting Item:** the Committee is making recommendations requiring a vote by the active members of NCWM; **(W) Withdrawn Item:** the item has been removed from consideration by the Committee.

Table C provides a summary of the results of the voting on the Committee’s items and the report in its entirety. Some Voting Items are considered individually; others may be grouped in a consent calendar. Consent calendar items are Voting Items that the Committee has assembled as a single Voting Item during their deliberation after the Open Hearings on the assumption that the items are without opposition and will not require discussion. The Voting Items that have been grouped into consent calendar items will be listed on the addendum sheets. Prior to adoption of the consent calendar, the Committee entertains any requests from the floor to remove specific items from the consent calendar to be discussed and voted upon individually.

Proposed revisions to the handbook(s) are shown as follows. 1) deleted language is indicated with a **bold face font using strikeouts** (e.g., ~~this report~~), and 2) proposed new language is indicated with an **underscore bold faced font** (e.g., new items). When used in this report the term “weight” means “mass”.

**Note:** The policy of NIST is to use metric units of measurement in all of its publications; however, recommendations received by NCWM technical committees and regional weights and measures associations have been printed in this publication as submitted. Therefore, the report may contain references to inch-pound units.



**Subject Series List**

Introduction .....	200 Series
NIST Handbook 130 – General .....	210 Series
Uniform Laws.....	220 Series
Uniform Weights and Measures Law .....	221 Series
Uniform Weighmaster Law .....	222 Series
Uniform Engine Fuels and Automotive Lubricants Inspection Law .....	223 Series
Uniform Regulations .....	230 Series
Uniform Packaging and Labeling Regulation .....	231 Series
Uniform Regulation for the Method of Sale of Commodities .....	232 Series
Uniform Unit Pricing Regulation .....	233 Series
Uniform Regulation for the Voluntary Registration of Servicepersons and Service Agencies for Commercial Weighing and Measuring Devices.....	234 Series
Uniform Open Dating Regulation .....	235 Series
Uniform Regulation for National Type Evaluation .....	236 Series
Uniform Engine Fuels and Automotive Lubricants Regulation .....	237 Series
Examination Procedure for Price Verification.....	240 Series
NCWM Policy, Interpretations, and Guidelines, Section 2 .....	250 Series
NIST Handbook 133.....	260 Series
Other Items – Developing Items.....	270 Series

**Table A  
Table of Contents**

<b>Reference Key</b>	<b>Title of Item</b>	<b>L&amp;R Page</b>
<b>200</b>	<b>INTRODUCTION.....</b>	<b>1</b>
<b>221</b>	<b>NIST HANDBOOK 130 – UNIFORM WEIGHTS AND MEASURES LAW .....</b>	<b>5</b>
221-1	W Section 1.8. Net “Mass” or Net “Weight.” .....	5
<b>231</b>	<b>NIST HANDBOOK 130 – UNIFORM PACKAGING AND LABELING REGULATION.....</b>	<b>8</b>
231-1	V Sections 6.4., 6.5., and 6.7. Addition of Tables .....	8
<b>232</b>	<b>NIST HANDBOOK 130 – UNIFORM REGULATION FOR THE METHOD OF SALE COMMODITIES.....</b>	<b>13</b>
232-1	I Section 1.5. Meat, Poultry, Fish, and Seafood.....	13
232-2	W Section 2.20.3. Street Sign Prices and Advertising.....	16
232-3	V Section 2.23. Animal Bedding .....	19
232-4	V Section 2.27. Retail Sales of Natural Gas Sold as a Vehicle Fuel.....	22
<b>237</b>	<b>NIST HANDBOOK 130 – UNIFORM ENGINE FUELS AND AUTOMOTIVE LUBRICANTS REGULATION .....</b>	<b>27</b>
237-1	V Section 1. 1.36. Liquefied Natural Gas (LNG) and Section 3.11. Compressed Natural Gas (CNG).....	27
237-2	I Sections 2.1.3. Minimum Antiknock Index (AKI), Section 2.1.4. Minimum Motor Octane Number, and Section 3.2.5. Prohibition of Terms – Table 1.....	36

237-3	V	Section 4.3. Dispenser Filters .....	39
<b>260</b>		<b>HANDBOOK 133 .....</b>	<b>42</b>
260-1	V	Section 2.7. Chitterling Test Procedure. ....	42
260-2	V	Section 3.9. Dimensional Test Procedure for Verifying the Compressed Quantity Declaration on Packages of Peat Moss.....	49
260-3	V	Section 3.15. Test Procedure for Verifying the Usable Volume Declaration on Packages of Animal Bedding.....	58
<b>270</b>		<b>OTHER ITEMS .....</b>	<b>74</b>
270-1	D	Fuels and Lubricants Subcommittee .....	74
270-2	D	Packaging and Labeling Subcommittee .....	75
270-3	D	Moisture Allowance Task Group (MATG).....	76

---

### Appendices

---

A	Items 232-4 and 237-1: NIST Handbook 130, Background and Justification for Handbook 130, Definition for “Diesel Gallon Equivalent (DGE)” of Compressed Natural Gas (CNG) and Liquefied Natural Gas (LNG) as a Vehicular Fuel.....	A1
B	Item 260-1: Handbook 133, Section 2.7. Chitterling Test Procedures, How to Determine the Net Weight and Purge of Packaged Chitterlings Using, Executive Summary and Supporting Documentation .....	B1
C	Items 232-3, 260-2, and 260-3: NIST Handbook 133, Testing Packages of Animal Bedding and Peat Moss with Compressed/Expanded Volume Declarations, Executive Summary and Supporting Documentation .....	C1

---

**Table B**  
**Glossary of Terms and Acronyms**

---

Acronym	Term	Acronym	Term
AAP	Average Adjusted Purge	HB 44	NIST Handbook 44, “Specifications, Tolerances, and Other Technical Requirements for Weighing and Measuring Devices”
AKI	Minimum Antiknock Index	IRS	Internal Revenue Service
ASTM	ASTM International	LNG	Liquefied Natural Gas
ATC	Automatic Temperature Compensation	MATG	Moisture Allowance Task Group
BTU	British Thermal Unit	MON	Motor Octane Number
CFR	Code of Federal Regulations	MAV	Maximum Allowable Variation
DGE	Diesel Gallon Equivalent	NIST	National Institute of Standards and Technology
DLE	Diesel Liter Equivalent	OWM	Office of Weights and Measures
DOE	Department of Energy	PALS	Packaging and Labeling Subcommittee

Acronym	Term	Acronym	Term
EPA	Environmental Protection Agency	RMFD	Retail Motor Fuel Dispenser
FALS	Fuels and Lubricants Subcommittee	S&T	Specifications and Tolerances
FDA	Food and Drug Administration	SCF	Sample Correction Factor
FPLA	Fair Packaging and Labeling Act	SEL	Sample Error Limit
FSIS	Food Safety and Inspection Service	SP	Special Publication
FTC	Federal Trade Commission	SWMA	Southern Weights and Measures
GGE	Gasoline Gallon Equivalent	TG	Task Group
GLE	Gasoline Liter Equivalent	UPLR	Uniform Packaging and Labeling Regulation
GM	General Motors	USNWG	U.S. National Work Group
L&R	Laws and Regulations	WG	Work Group
HB 133	NIST Handbook 133, "Checking the Net Contents of Packaged Goods"	WWMA	Western Weights and Measures Association

**Table C**  
**Voting Results**

Reference Key Number	House of State Representatives		House of Delegates		Results
	Yeas	Nays	Yeas	Nays	
231-1	39	0	62	0	Adopted
260-1	37	0	65	0	Adopted
260-2	39	0	67	0	Adopted
232-4*	32	8	26	31	Returned to Committee
237-1*	32	8	26	31	Returned to Committee
237-3	16	16	50	9	Returned to Committee

\* Items 232-4, 237-1 and 337-1 were voted upon as a block.

---

**Details of All Items**  
(In order by Reference Key)

---

**221 NIST HANDBOOK 130 – UNIFORM WEIGHTS AND MEASURES LAW****221-1 W Section 1.8. Net “Mass” or Net “Weight.”**

(This item was Withdrawn.)

**Source:**

The Kind Group (2015)

**Purpose:**

Amend the definition of “net weight” to include the normally/easily deliverable quantity.

**Item Under Consideration:**

Amend NIST Handbook 130, Uniform Weights and Measures Law as follows:

**1.8. Net “Mass” or Net “Weight.”** – The term “net mass” or “net weight” means the weight <sup>[NOTE 1, page 21]</sup> of a commodity excluding any materials, substances, or items not considered to be part of the commodity **and is limited to the amount easily (normally) available to the consumer.** Materials, substances, or items not considered to be part of the commodity include, but are not limited to, containers, conveyances, bags, wrappers, packaging materials, labels, individual piece coverings, decorative accompaniments, and coupons, except that, depending on the type of service rendered, packaging materials may be considered to be part of the service. For example, the service of shipping includes the weight of packing materials. **Materials or substances, whose evacuation is substantially constrained by platforms, tube limitations or other elements, are not considered to be part of the commodity.**

(Added 1998) (Amended 1989, 1991, ~~and~~ 1993, and 20XX)

**Background/Discussion:**

For a number of products, such as toothpaste, makeup and certain lip balms, the easily (normally) available quantity is less than the net weight; sometimes significantly so. As a result, consumers lose untold commodities that are largely inaccessible in these products.

The following are Committee Reports from 1990 and 1993 on a similar item.

**1990 L&R Committee Report:****10.X. Mechanical Pump Dispensers**

(This item was Informational.)

Sealed mechanical pumps are a relatively new dispensing mechanism for toothpaste. They dispense dentifrice through a sealed mechanism that will always retain a minimum amount of product. Only on aerosol containers must the net contents declaration be the amount that is delivered to the purchaser (see Section 10.3 of the UPLR). The Western Weights and Measures Association recommended that a new section be added to the UPLR requiring these new types of packages to declare on their labels the total weight of product that will be delivered. The proposal was:

10.X. Mechanical Pump Dispensers. – The declaration of quantity on packages that deliver product through a nonremovable mechanical pump shall disclose the net quantity of the commodity that will be expelled when the instructions for use, as shown on the container, are followed.

At the present time, two problems are associated with this type of container:

- (1) The dispensing head will always retain a certain amount of product in it, which cannot be obtained using normal dispensing methods. However, the package label declares the contained net weight, not the delivered net weight.
- (2) Compliance testing officials are not sure what method to use to determine the amount of product contained (as opposed to the amount delivered). Unlike aerosol packages, there are no warning statements on the package prohibiting the opening of the package. However, if emptied in the manner simulating use, the net weight will be less than the net weight determined by means which bypass the mechanical pump head.

The Cosmetics, Toiletries, and Fragrance Association (CTFA) met with the Committee and outlined how the mechanical pumps could be tested by regulatory officials to determine the amount of product contained. They also pointed out that studies showed mechanical pumps delivered comparable amounts of product as compared with tubes or other dispensing mechanisms, such as plastic squeeze bottles or hand pumps. (CTFA member firms found that other types of containers retain from 4.2 to 10.1 percent of labeled amounts without resorting to such extraordinary measures as cutting the containers apart, disassembling them, or waiting excessive periods of time for them to empty.) Another study showed that when consumers were asked to return tubes and mechanical pumps of toothpaste that they thought were "empty," pumps retained 4 to 5 percent of the labeled contents, while tubes retained 8 to 9 percent. Even though aggressive consumers *can* cut into a tube (but cannot do that to a pump), this study showed that they did not cut into the tube.

CTFA expressed concern that another declaration indicating the amount delivered in addition to the declaration presently on the packages (the amount contained) would be confusing. The Committee had not intended to require two declarations, but had interpreted the proposal as changing the net contents declaration, rather than adding one. Since such a requirement would be at variance with the traditional interpretation of the required net contents declaration (except for aerosols), the Committee is aware that the proposed section might be a solution that might require changes or additions to FDA regulations. However, it should be pointed out that certain segments of industry already provide a net contents statement that is the delivered amount; for example, many stick deodorant packages are labeled on the back declaring "(so many) ounces plus enough extra to secure the product to the base (of the dispenser)." The Committee will be carrying this item over for further study. See also Item 232-18 for further discussion.

Data collected in California indicated that mechanical pumps delivered from 89.5 to 100 percent of their declared net weights. The CTFA acknowledged that the various pumps now on the market have somewhat different dispensing characteristics. Mr. Ken Appell, Colgate-Palmolive Co., presented information concerning the possible causes of difference between California's and CTFA's data. They included the temperature at the time of measurement, the age of the product, the rate of use (fast, total dispensing vs. normal unit daily dosing), and container size (the size of the reservoir on the mechanical pump head compared with the size of the container, as well as the particular mechanical pump design). Other jurisdictions are urged to test both mechanical pumps and tubes and report their findings to the Committee. Data should include lot code information, temperature of test, and method of emptying the container, as well as container and package information, such as brand, product, and container net contents. It would be useful for the jurisdiction to test two samples of the same product, one to determine the delivered contents and one to determine the contained contents. Please contact the Office of Weights and Measures, Ms. Carroll Brickenkamp, (301) 975-4005, for information on determining the contained net contents.

**1993 L&R Committee Report:  
Mechanical Pump Dispensers**  
(This item was Withdrawn.)

**Background:** This was Item 231-13 in the Report of the 75th NCWM, 1990, pages 89-90, Item 231-6 in the “Report of the 76th NCWM,” 1991, page 200; and Item 231-3 in the “Report of the 77th NCWM,” 1992, page 135. See these reports for a full discussion of the issue. The Committee considered submitting a petition to the Food and Drug Administration (FDA) and the Federal Trade Commission (FTC) to request changes in Federal regulations to require mechanical pump package systems to dispense the labeled weight. Prior to the 77th NCWM Annual Meeting, the Committee received comments from industry and weights and measures officials expressing concern over the possible impact of a “to deliver” requirement on other types of packaging, including toothpaste tubes and hand-pump dispensers (such as those used for hand lotions) that are currently only required to contain the labeled quantity. Several people questioned how far the requirement would reach and whether the economic impact would benefit consumers or lessen the competitive position of manufacturers who use this type of packaging. The Committee did not hear any comments on this item *at* the Interim Meeting that indicated a significant problem with this type of packaging or that there is national support for further action on the issue. The Committee sought industry participation in further studies due to its concern about product retained by the package delivery system of mechanical pump dispensers, but only one firm expressed concern about the issue. Therefore, the Committee is withdrawing this item from its agenda. The Committee would welcome information on this item in the future. Such information could include the results of investigations into consumer complaints or results of actual product testing or recent net content studies on a wide variety of consumer products that use this type of container.

For additional information, contact Mr. Jonathan Teller, The Kind Group via e-mail: [Jonathon@thekindgroup.com](mailto:Jonathon@thekindgroup.com) or Mr. Mike Sikula, New York State Weights and Measures at (518) 457-3452.

NCWM 2015 Interim Meeting: A comment was made that this item was addressed by the Conference in the 1990s and packaged commodities have not changed in how they are packaged or dispensed. Adoption of this proposal would create confusion in the marketplace for consumers. If accepted the Conference would need to consult with other federal agencies to see if it conflicts with their regulations. There is not enough data or support to move this item forward. The Committee agrees that, if adopted, defining the term “to deliver” would be difficult. This would also impact the current test procedures in NIST Handbook 133. The L&R Committee believes that packaging has not changed since this was reviewed by the Conference in the 1990s. There was also no evidence or data from other manufacturers that this is an issue. Two regional associations did not forward this item to the Conference for consideration. For these reasons the Committee Withdrew this item.

**Regional Association Comments:**

CWMA: The CWMA discussed the meaning of “normally/easily.” It is an ambiguous term and can be interpreted differently by individuals. The CWMA requested clarification on whether the residual contents would be considered as tare. Individuals from both the regulatory community and industry expressed some concern about the concept of “normally/easily deliverable.” One suggestion by a regulator was to amend the language from “contains” net weight to “delivered” net weight. Several examples of residual substances were discussed. One regulator suggested leaving the proposal as a developing item as referenced in the proposal from 1993. One regulator said it would be overwhelming to try to determine what the “cling” or residual would be on all package checking. The CWMA forwarded the item to NCWM recommending it as a Developing item.

WWMA: The WWMA noted that adoption of this item would necessitate changes to NIST Handbook 133. A manufacturer stated that if this proposal is adopted, manufacturers would have difficulty complying with the standard created by the new definition. A regulator stated that the proposed change is not necessary and that it would be difficult for regulators to enforce. One regulator agreed with the concept of net weight being defined “to deliver” but that this would create difficulty with test procedures currently documented, and that this is similar to the discussion about the difference between wet and used dry tare.

A similar item was considered by the NCWM in the early 1990s and ultimately Withdrawn due to enforcement

difficulty for regulators and difficulty of compliance by manufacturers. Since then, packaging technology has not changed significantly and the WWMA wondered what new problem it is that needs to be addressed. Currently, there is only one manufacturer seeking this change. It was also noted that the NCWM and NIST would have to consult with other federal agencies (e.g., FTC, FDA, and EPA to ensure this change would not conflict with other agencies' definitions). The WWMA did not forward this item to the NCWM.

NEWMA: NEWMA received an explanation from the submitter of this item justifying the need for this proposal. He explained that the product in question has content weight that is not intended for consumption. The submitter is asking to change the definition of net weight to include only the consumable contents of the product. The Committee Chair cited the federal regulation that lists the definition for net content, and asked how the submitter would reconcile this proposal with the federal regulation. The submitter indicated he did not believe there was a conflict with federal regulation. The submitter said that the upper half of the container is for packaging purposes, not for consumption purposes, so it should not be included in the weight. A regulator asked if other manufacturers were looking at this issue differently than the submitter. The submitter stated that there is confusion, but no manufacturer opposes the idea to his knowledge. The regulator feels it is a legitimate issue and merits further consideration. The Chairman commented that two other regions Withdrew the item, and one made it informational. A regulator stated that as a consumer, she would want to know what content is in the dispenser that is usable. Two additional regulators believed it should go forward as an Informational item for further consideration, which was the overall consensus at the NEWMA 2014 Interim Meeting. NEWMA forwarded the item to the NCWM and recommended that it be an Informational item.

SWMA: At the SWMA 2014 Annual Meeting, the Committee heard comments from industry that they believed this was a step backwards and would require multiple changes in test procedures. Comments were heard that multiple test procedures would have to be drafted to test many different items. The SWMA did not forward this item to NCWM.

Additional letters, presentations, and data may have been part of the Committee's consideration. To review the supporting documentation, please refer to the *Report of the 99<sup>th</sup> National Conference on Weights and Measures* (SP1193, 2014).

## **231 NIST HANDBOOK 130 – UNIFORM PACKAGING AND LABELING REGULATION**

### **231-1 V Sections 6.4., 6.5., and 6.7. Addition of Tables**

(This item was Adopted.)

**Source:**

NCWM Packaging and Labeling Subcommittee (2014)

**Purpose:**

Add tables to Handbook 130, Uniform Packaging and Labeling Regulation to help clarify requirements.

**Item Under Consideration:**

Amend NIST Handbook 130, Uniform Packaging and Labeling Regulation as follows:

**6.4. Terms: Weight, Measure, Volume, or Count.** – The declaration of the quantity ~~of a particular commodity~~ shall be expressed in terms of **Table 6.4.:**

- ~~(a) weight if the commodity is solid, semisolid, viscous, or a mixture of solid and liquid;~~
- ~~(b) volume measure if the commodity is liquid or dry, if the commodity is dry;~~
- ~~(c) linear measure or area; or~~

~~(d) numerical count.~~

<b>Table 6.4.</b> <b>Weight, Measure, Volume, or Count</b>	
<b><u>If the commodity is:</u></b>	<b><u>The declaration of the quantity of a particular commodity shall be expressed in terms of:</u></b>
(a) <b><u>solid, semisolid, viscous, or a mixture of solid and liquid</u></b>	<b><u>weight or mass</u></b>
(b) <b><u>liquid</u></b>	<b><u>fluid volume measure</u></b>
(c) <b><u>dry</u></b>	<b><u>dry measure</u></b>
(d) <b><u>or labeled by linear measure or area</u></b>	<b><u>linear measure or area</u></b>
(e) <b><u>or labeled by numerical units (count)</u></b>	<b><u>numerical count</u></b>

However, if there exists a firmly established general consumer usage and trade custom with respect to the terms used in expressing a declaration of quantity of a particular commodity, such a declaration of quantity may be expressed in its traditional terms, provided such traditional declaration gives accurate and adequate information as to the quantity of the commodity. Any net content statement that does not permit price and quantity comparisons is forbidden.

(Amended 1989 **and 2015**)

**6.5. SI Units: Mass, Measure.** <sup>[NOTE 3, page 64]</sup> – A declaration of quantity **shall be expressed in terms of Table 6.5. and the requirements in 6.5.(f), 6.5.(g), and 6.5.(h):**

<b>Table 6.5.</b> <b>SI Units: Mass, Measure</b>	
<b><u>If a declaration of quantity is in units of:</u></b>	<b><u>The units shall be in:</u></b>
(a) <b><u>mass</u></b>	<b><u>kilogram, gram or milligram</u></b>
(b) <b><u>liquid measure</u></b>	<b><u>liter or milliliter and shall express the volume at 20 °C, except for:</u></b>  <b><u>petroleum products or distilled spirits for which the declaration shall express the volume at 15.6 °C, and</u></b>  <b><u>a commodity that is normally sold and consumed while frozen for which the declaration shall express the volume at the frozen temperature, and</u></b>  <b><u>malt beverages or a commodity that must be maintained in the refrigerated state, for which the declaration shall express the volume at 4 °C.</u></b>
(c) <b><u>linear measure</u></b>	<b><u>meter, centimeter, or millimeter</u></b>
(d) <b><u>area measure</u></b>	<b><u>square meter, square decimeter, square centimeter, or square millimeter</u></b>



**Table 6.5.**  
**SI Units: Mass, Measure**

<u>If a declaration of quantity is in units of:</u>	<u>The units shall be in:</u>
<u>(e) volume other than liquid measure</u>	<u>liter or milliliter, except that units cubic meter and cubic centimeter shall be used only when specifically designated as a method of sale</u>

(Amended 1985, 1990, and 2015)

- ~~(a) in units of mass shall be the kilogram, gram, or milligram;~~
- ~~(b) in units of liquid measure shall be the liter or milliliter and shall express the volume at 20 °C, except in the case of petroleum products or distilled spirits, for which the declaration shall express the volume at 15.6 °C, and except also in the case of a commodity that is normally sold and consumed while frozen, for which the declaration shall express the volume at the frozen temperature, and except also in the case of malt beverages or a commodity that must be maintained in the refrigerated state, for which the declaration shall express the volume at 4 °C;~~

~~(Amended 1985 and 1990)~~

- ~~(c) in units of linear measure shall be the meter, centimeter, or millimeter;~~
- ~~(d) in units of area measure shall be the square meter, square decimeters, square centimeter, or square millimeter;~~
- ~~(e) in units of volume other than liquid measure shall be the liter and milliliter, except that the units cubic meter and cubic centimeter shall be used only when specifically designated as a method of sale;~~
- (f) Rule of 1000. – The selected multiple or submultiple prefixes for SI units shall result in numerical values between 1 and 1000. This rule allows centimeters or millimeters to be used where a length declaration is less than 100 centimeters.

**Examples:**

500 g, not 0.5 kg;  
1.96 kg, not 1960 g;  
750 mL, not 0.75 L; or  
750 mm or 75 cm, not 0.75 m

(Added 1993)

- (g) SI declarations should be shown in three digits except where the quantity is below 100 grams, case, any final zero appearing to the right of the decimal point need not be shown; and milliliters, centimeters, square centimeters, or cubic centimeters, where it may be shown in two digits. In either
- (Added 1993)
- (h) the declaration of net quantity of contents shall not be expressed in mixed units.

**Example:**

1.5 kg, not 1 kg 500 g.

(Added 1993)

**6.7. U.S. Customary Units: Weight, Measure.** – A declaration of quantity shall be expressed in terms of Table 6.7.:

- ~~(a) in units of weight shall be in terms of the avoirdupois pound or ounce;~~
- ~~(b) in units of liquid measure shall be in terms of the United States gallon of 231 in<sup>3</sup> or liquid quart, liquid pint, or fluid ounce subdivisions of the gallon and shall express the volume at 68 °F, except in the case of petroleum products and distilled spirits, for which the declaration shall express the volume at 60 °F, and except also in the case of a commodity that is normally sold and consumed while frozen, for which the declaration shall express the volume at the frozen temperature, and except also in the case of a commodity that must be maintained in the refrigerated state, for which the declaration shall express the volume at 40 °F, and except also in the case of malt beverages, for which the declaration shall express the volume at 39.1 °F;~~
- ~~(Amended 1985 and 1990)~~
- ~~(c) in units of linear measure shall be in terms of the yard, foot, or inch;~~
- ~~(d) in units of area measure shall be in terms of the square yard, square foot, or square inch;~~
- ~~(e) in units of volume measure shall be in terms of the cubic yard, cubic foot, or cubic inch; and~~
- ~~(f) in units of dry measure shall be in terms of the United States bushel of 2150.42 in<sup>3</sup>, or peck, dry quart, and dry pint subdivisions of the bushel.~~

<u>Table 6.7.</u> <u>U.S. Customary Units: Weight, Measure</u>	
<u>If a declaration of quantity is in units of:</u>	<u>The units shall be in:</u>
(a) <u>weight</u>	<u>avoirdupois pound or ounce</u>
(b) <u>liquid measure</u>	<p><u>U.S. gallon of 231 in<sup>3</sup> or liquid quart, liquid pint or fluid-ounce subdivisions of the gallon and shall express the volume at 68 °F, except in cases of:</u></p> <p style="padding-left: 40px;"><u>petroleum products or distilled spirits for which the declaration shall express the volume at 60 °F;</u></p> <p style="padding-left: 40px;"><u>a commodity that is normally sold and consumed while frozen, for which the declaration shall express the volume at the frozen temperature;</u></p> <p style="padding-left: 40px;"><u>a commodity that must be maintained in the refrigerated state, for which the declaration shall express the volume at 40 °F; and</u></p> <p style="padding-left: 40px;"><u>malt beverages for which the declaration shall express the volume at 39.1 °F.</u></p>
(c) <u>linear measure</u>	<u>yard, foot, or inch</u>
(d) <u>area measure</u>	<u>square yard, square foot, or square inch</u>
(e) <u>volume measure</u>	<u>cubic yard, cubic foot, or cubic inch</u>

<u>Table 6.7.</u> <u>U.S. Customary Units: Weight, Measure</u>	
<u>If a declaration of quantity is in units of:</u>	<u>The units shall be in:</u>
(f) <u>dry measure</u>	<u>U.S. bushel of 2150.42 in<sup>3</sup>, or peck, dry quart, and dry pint subdivisions of the bushel</u>

(Amended 1985, ~~and~~ 1990, and 2015)

**Background/Discussion:**

The tables were developed from a PowerPoint presentation provided at a NIST Packaging and Labeling Training Seminar for industry and regulators. Attendees found the tables to be an excellent reference source as they were challenged to evaluate various packaged commodities for compliance with the Uniform Packaging and Labeling Regulation (UPLR). These individuals represented a wide range of businesses, and could be considered a good representation of industry in general.

The addition of tables to NIST Handbook 130, UPLR, would be useful to industry and regulators in interpreting requirements. No revisions of current requirements would be necessary. Marketing and art departments, amongst others, are challenged with developing the packaging and labeling for products being distributed by their companies or clients, and individuals in those professions would find it helpful to have the additional examples provided in the tables for reference.

Several other tables are already provided in NIST Handbook 130, and these new tables are viewed as being equally helpful. For example, in NIST Handbook 130 (2014), UPLR, Table 1. Rounding Rules (page 98) describes rounding rules and Table 2. Examples (page 100) provides conversions tables.

NCWM 2014 Interim Meeting: It was mentioned that there are numerous technical and typographical errors within the submitted charts. The subsections in the tables do not coincide with the language printed within NIST Handbook 130, UPLR. During Committee work session it was mentioned that developing tables for items within the NIST handbooks could set a precedence for all items to have a table. NIST commented that they do provide a publication, NIST SP 1020 Series, *Consumer Packaging Labeling Guides*. The NIST SP 1020 Guides are quite popular and extremely user-friendly. The Committee would like to have feedback from the Regions on this item. They also requested the PALS (original submitter) correct the tables to align with the language as it appears with the handbook.

NCWM 2015 Interim Meeting: The PALS Chair submitted modifications to the Item Under Consideration. PALS decided not to add tables for Sections 6.8.1., 6.8.2., and 6.9. The PALS Chair remarked that the Subcommittee has completed their review on this section and will not develop additional tables in this section of the handbook. The NIST Technical Advisor will review for technical and editorial clarity, so that members will have a finalized version for the NCWM Annual Meeting. The Committee encourages NIST, OWM to proceed with updating the NIST SP 1020 Series, "*Consumer Packaging and Labeling Guides*." The 2015 L&R Committee is designating this as a Voting item.

NCWM 2015 Annual Meeting: During Open Hearings, Mr. Kurt Floren (Director, Los Angeles County) remarked that this has been reviewed by a large group of California sealers and they see no conflict. There is concern that if this language is directly from the Fair Packaging and Labeling Act (FPLA) and federal regulations, any omission of words could be a conflict. Mr. Guay (PALS Chair) clarified that the current NIST Handbook 130, UPLR language is not identical to the language in the FPLA.

**Regional Association Comments:**

CWMA 2014 Interim Meeting: The CWMA heard no comments were heard during the L&R Committee Open Hearings. The CWMA believes this item has merit but agrees the PALS needs to further Develop the item. At the 2015 CWMA Annual Meeting, it was reported that the item has been fully developed and two other regions have recommended that the item be a Voting item. There were no additional comments from the Central region.

WWMA: WWMA noted that replacing text with tables in NIST Handbook 130, UPLR has merit, but the tables should be vetted for technical accuracy and consistency with the language and intent of the FTC's FPLA.

WWMA 2014 Annual Meeting: The Committee recommended this item be Informational and encouraged the PALS to finish its amendments to the UPLR and submit one complete package; this would prevent the NCWM and regional committees from having to consider similar proposals over multiple years. WWMA also encouraged NIST to market its NIST SP 1020 series publications (guidebooks based upon the UPLR) to weights and measures stakeholders. There is no change to existing language in the UPLR. This proposal is taking existing language and placing it in a readable table format. The tables are supplemental and not intended to replace what is currently published. The PALS Chair added that the intent is to be content neutral, noting that putting it in a table format is user-friendly.

SWMA 2014 Meeting: The PALS Chair commented that he submitted a modification that differs from language that appears in the agenda as Item under Consideration. SWMA recommended that the item be a Voting item.

NEWMA 2014 Interim Meeting: The amended language from PALS was considered and the proposal was considered fully developed. NEWMA recommended that this item be a Voting item.

2015 NEWMA and CWMA Annual Meeting: The item was reviewed as it appeared in Publication 16. Both regions consider this proposal fully developed and recommend that it be a Voting item.

Additional letters, presentations, and data may have been part of the Committee's consideration. To review the supporting documentation, please refer to the *Report of the 99<sup>th</sup> National Conference on Weights and Measures* (SP1193, 2014).

## **232 NIST HANDBOOK 130 – UNIFORM REGULATION FOR THE METHOD OF SALE COMMODITIES**

### **232-1 I Section 1.5. Meat, Poultry, Fish, and Seafood.**

**Source:**

Massachusetts Division of Standards (2015)

**Purpose:**

To allow the retail sale of meat, poultry and fish by count with adequate consumer information.

**Item Under Consideration:**

Amend NIST Handbook 130 Uniform Regulation for the Method of Sale of Commodities as follows:

**1.5. Meat, Poultry, Fish, and Seafood.** <sup>[NOTE 3, page 110]</sup> – Shall be sold by weight or count, except that whole shellfish in the shell may also be sold by ~~weight, measure, and/or count~~. Shellfish are aquatic animals having a shell, such as mollusks (for example, scallops) or crustaceans (for example, lobster or shrimp). **If sold by count, the net weight and the corresponding unit price shall be displayed on the principal display panel of the product. The unit price when sold by count shall also be advertised or displayed in terms of whole weight units of kilograms, pounds or ounces only, not in common or decimal fractions.**

**(Amended 20XX)**

**Background/Discussion:**

Several jurisdictions have reported that meat and meat products are routinely being sold by count both with and without a net weight declaration or unit price, many times alongside meat products that are being sold by weight. This approach does not give the consumer enough information to make value comparisons and may be misleading; however, it is believed this amendment will remedy this. Retailers will benefit from this amendment by having more options for the method of sale of these products; consumers will benefit from this amendment because they will be

able to make informed value comparisons; and weights and measures officials will be able to ensure accuracy of net weight declarations and unit price calculations.

NCWM 2015 Interim Meeting: A regulator remarked that the regulations are clearly defined in the handbook and any changes would cause confusion. Several states opposed this item as written. The NIST Technical Advisor remarked that this item was posted on the NIST State Director List Server and several states expressed concern on labeling issues in the marketplace. The State of Florida commented that they had an issue in their marketplace but worked directly with the grocers to clarify. The NIST Technical Advisor presented the following to the Committee for review:

**1.5 Meat, Poultry, Fish, and Seafood.** <sup>[NOTE 3, page 110]</sup> – Shall be sold by weight, except that whole shellfish in the shell may be sold by weight, measure, and/or count. Shellfish are aquatic animals having a shell, such as mollusks (for example, scallops) or crustaceans (for example, lobster or shrimp). **The net weight declaration for meat, poultry, fish and seafood shall be by the kilogram, gram or pound and not by portion or piece except as permitted below:**

(Amended 1998 **and 20XX**)

**(a) If meat, poultry, fish, and seafood is kept, offered or exposed for sale or sold at the retail store level in standard weight packages (refer to the Uniform Packaging and Labeling Regulation (UPLR), Section 6.16., Random Packages) the net weight, total price and unit price must appear on the principal display panel of each package and must conform to all of the applicable requirements of the UPLR. This section does not apply to packages of meat or poultry that bear a USDA Inspection Seal and plant identity and a label that conform to the net weight labeling requirements of the USDA Food Safety and Inspection Service (FSIS).**

**(b) If meat, poultry, fish, and seafood is kept, offered or exposed for sale from bulk (e.g., direct service counters) by the portion or piece, the product identity and net weight shall be displayed along with the unit price at which it is offered for sale. This information shall appear on a label or sign adjacent to the meat, poultry, fish or seafood and must be presented in an easy-to-read type style and color and must appear on a single-color contrasting background.**

**(c) The unit prices required under Sections 1.5.(a) and 1.5.(b) shall be in terms of the unit price-per-kilogram; or unit price-per-100 grams; or unit price-per-pound, and not in any other unit or denomination or in common or decimal fractions of the permitted units.**

**(Added 20XX)**

The traditional method of sale for meat and poultry at retail has been to sell by the pound in decimal units (i.e., 1.59 lb). In NIST Handbook 44, S.1.8.4., Customer Indications in the 2.20. Scale Code it requires the display of the whole units of weight but permits unit pricing for metric units to appear as price per kilogram or price per 100 g. Any proposal in the method of sale should be consistent with the scale code or retailers will not have the equipment they need to do the job.

NIST, OWM understands that retailers are attempting to shift from the traditional method of sale of decimal pounds over to the sale of meat by the piece, but still by weight (but in ounces). This is currently acceptable; however, as this practice is emerging in many states, it appears to hinder or frustrate the consumer's ability to make value comparisons between packaged meat and sales from bulk.

At least one state has obtained a court ruling that prohibits the sale of the same product by different methods of sale within the same retail location, specifically because it hinders value comparison.

In the example given below, the consumer will have to divide the price by ounces to obtain a price per ounce and multiply that value by 16 to obtain a price per pound, to compare the unit price offered in the bulk sales counter to the unit price of the same identical type of meat offered for sale in a random weight prepackage by the decimal pound.

For example:  $\$5.99 \div 5 = \$1.198$  per ounce  $\times 16 = \$19.16$  per pound

It appears that to maintain the traditional method of sale and pricing (i.e., offered by sale by decimal pounds and unit pricing by the pound) the Method of Sale Regulation (and, because not all states adopt the method of sale regulation, perhaps the UPLR) should be revised to only permit sales by the decimal pound or kilogram, and unit prices be revised to only appear in terms of price per pound or kilogram (or price per 100 grams [per NIST Handbook 44]). For sales of food from bulk, unit price advertising by the ounce should be prohibited in Sections 1.9.1 and 1.9.2.

Another suggestion provided by NIST, OWM is to change the title of Section 1.9. Advertising and Price Computing of Bulk Food Commodities to read:

**1.9. Advertising and Price Computing of Bulk Food and Prepackaged Food Commodities.**

**1.9.1. Total Price Computing.** – The **total** price of food commodities sold from bulk **and in packages shall be** by weight **and the total price** shall be computed in terms of whole units of weight (i.e., **price per 100 grams, or price per kilogram, or price per pound, ounces, etc.**) and not in common or decimal fractions.

**1.9.2. Unit Price Advertising.** – The **unit** price of food commodities sold from bulk **and in packages** shall be advertised or displayed in terms of whole **units of** weight in kilograms, **(or price per 100 grams)** or pounds only, not in common or decimal fractions. **or in ounces.** A supplemental declaration is permitted in print no larger than the whole unit price. This supplemental declaration may be expressed in common or decimal fractions. **or in ounces.**

**1.9.3. Individual Piece Advertising.** – **The unit price and net weight of food commodities offered or exposed for sale by the each from bulk shall include a declaration of the individual item price, a unit price in terms of decimal kilograms or pounds or price per 100 grams and net weight in terms of decimal kilograms or pounds. The net weight and unit price declaration shall be presented adjacent to the item price in type size no less than one-half the height of the item price and shall be displayed as clear and conspicuous as the item price.**

**For example:      Tuna Steaks**  
**\$5.99 each**

**NET WT 0.31 LB**  
**\$19.16 PER LB**

Various pricing schemes found in the marketplace by the states:



Being Sold by Each.



Identifier on the Label States “5 oz bnl's pork chops.” The Random Pack Label has a Net Weight that Differs from Package to Package.

NCWM 2015 Interim Meeting: The Committee heard comments to withdraw this item. The Committee would like to receive additional feedback from all the Regions. For these reasons, the Committee is recommending this be an Informational item.

NCWM 2015 Annual Meeting: The NIST Technical Advisor remarked that states have different interpretations for Section 1.5. Meat Poultry, Fish and Seafood. Some states believe this is a non-issue and does not need to be addressed through the Conference. Some states were able to work directly with retailers in resolving any issues. A primary concern is there needs to be uniformity in the marketplace. There are two separate issues; one being the method of sale on prepackaged products and the second being the method of sale when sold by bulk. NIST Handbook 130 does not provide guidance for some of the marketing practices seen in today's marketplace. NIST also has been in contact with a state that is having issues with markdown labels. If the NCWM approves the Committee's request that a work group (WG) be formed, NIST will facilitate a WG that consists of regulatory officials and retailers working together to review this item and provide a recommendation at the NCWM 2016 Interim Meeting.

**Regional Associations Comments:**

NEWMA 2014 Interim Meeting: During the meeting the submitter of this item commented that cuts of meat, poultry, and fish are being sold by count rather than the weight. He believes the pound comparison should be required so consumers can make educated price comparisons. Another regulator agreed. An industry representative from a supermarket asked if cuts could still be sold individually for a fixed amount if both the cost per pound and the cost per item are posted. The submitter explained that in his state, the price per pound should be the primary price listing. However, a supplemental statement would not be prohibited. The Chairman proposed alternative language to avoid a conflict with the Federal Packaging and Labeling Act (FPLA). The submitter asked the Chairman to confirm whether or not the new language would be in violation. An industry representative asked what the package labeling had to contain. The submitter answered that all packaging for meat, poultry, fish, and seafood in his state has to include the net weight, total price, and price per pound. NEWMA forwarded the item as submitted to NCWM and recommended that this be an Informational item. During the 2015 NEWMA Annual Meeting, a NIST Technical Advisor commented that this item came from regulators in Massachusetts and Florida. States have concerns there is not adequate regulation in addressing this section and the national L&R Committee is seeking comments from regions. NEWMA is recommending this be an Informational item pending comments from the states.

CWMA 2015 Annual Meeting: Several regulators commented that products are being sold by "each," but they also require the weight to be posted on the item. A NIST representative rose to provide clarification on the item for consideration and discussed that retailers are selling product by random weight, standard pack, and by bulk as count alone or by fixed weight. This item should be considered if states believe there is a need for a consistent pricing method (sold by pound only). The CWMA agrees this item has merit and should be kept as Informational.

Additional letters, presentations, and data may have been part of the Committee's consideration. To review the supporting documentation, please refer to the *Report of the 99<sup>th</sup> National Conference on Weights and Measures* (SP1193, 2014).

**232-2 W Section 2.20.3. Street Sign Prices and Advertising**

(This item was Withdrawn.)

**Source:**

Retail Motor Fuel Dispenser Price Posting and Computing Capabilities Task Group (2014)

**Purpose:**

Ensure that consumers are not charged a higher price per gallon for motor fuel than what is advertised on a street sign.

**Item Under Consideration:**

Amend Handbook 130, Uniform Regulation for the Method of Sale of Commodities as follows:

**2.20. Gasoline-Oxygenate Blends.**

**2.20.1. Method of Retail Sale.** – Type of Oxygenate must be Disclosed – All automotive gasoline or automotive gasoline-oxygenate blends kept, offered, or exposed for sale, or sold at retail containing at least 1.5 mass percent oxygen shall be identified as “with” or “containing” (or similar wording) the predominant oxygenate in the engine fuel. For example, the label may read “contains ethanol” or “with MTBE.” The oxygenate contributing the largest mass percent oxygen to the blend shall be considered the predominant oxygenate. Where mixtures of only ethers are present, the retailer may post the predominant oxygenate followed by the phrase “or other ethers” or alternatively post the phrase “contains MTBE or other ethers.” In addition, gasoline-methanol blend fuels containing more than 0.15 mass percent oxygen from methanol shall be identified as “with” or “containing” methanol. This information shall be posted on the upper 50 % of the dispenser front panel in a position clear and conspicuous from the driver’s position in a type at least 12.7 mm (½ in) in height, 1.5 mm (1/16 in) stroke (width of type).

(Amended 1996)

**2.20.2. Documentation for Dispenser Labeling Purposes.** – At the time of delivery of the fuel, the retailer shall be provided, on an invoice, bill of lading, shipping paper, or other documentation, a declaration of the predominant oxygenate or combination of oxygenates present in concentrations sufficient to yield an oxygen content of at least 1.5 mass percent in the fuel. Where mixtures of only ethers are present, the fuel supplier may identify either the predominant oxygenate in the fuel (i.e., the oxygenate contributing the largest mass percent oxygen) or, alternatively, use the phrase “contains MTBE or other ethers.” In addition, any gasoline containing more than 0.15 mass percent oxygen from methanol shall be identified as “with” or “containing” methanol. This documentation is only for dispenser labeling purposes; it is the responsibility of any potential blender to determine the total oxygen content of the engine fuel before blending.

(Added 1984) (Amended 1985, 1986, 1991, and 1996)

**2.20.3. Street Sign Prices and Advertising.**

**(a) The unit price must be in terms of price per gallon in 1/10 cents.**

**(b) When the price of fuel increases, the street sign must be changed before or simultaneous when the price at the pump is changed. When the price of fuel decreases, the price at the pump must be changed before or simultaneous when the street sign price is changed.**

**(Added 20XX)**

**Background/Discussion:**

The consumer should never pay more for fuel than the advertised price. A street sign price posting that is lower than the price at the pump could unfairly draw business from a competitor.

NCWM 2014 Interim Meeting: The Committee heard from Mr. Hornbach (Chevron) who spoke in regards to electronic price signs that have the capability to change pumps and signs simultaneously. He recommends that the word “simultaneous” be added into the proposal. Ms. Elson-Houston (Chair of the Retail Motor Fuel Dispenser Price Posting and Computing Capabilities Task Group [TG]) concurs with this change. The Committee does not feel this item is developed enough and requests that the TG ensure that all sections of the method of sale are addressed in regards to price posting, multi-tier and dual pricing with fuels. The Committee would like the regions to review and comment on this item. Ms. Elson-Houston informed the Committee that the Price Posting TG will be disbanding in July 2014. At the 2014 NCWM Annual Meeting, the Committee agreed this item had merit and recommended that the submitter continue to develop.



NCWM 2015 Interim Meeting: The Chair of the Retail Motor Fuel Dispenser Price Posting and Computing Capabilities TG recommended to the Committee that this item be Withdrawn. Many regulators and state directors concurred with the decision of the TG Chair. The 2015 L&R Committee is designating this as a Withdrawn item.

**Regional Associations Comments:**

This item was submitted directly to the Standing Committee from the NCWM Price Posting TG after the deadlines for submitting to the regional associations.

NEWMA 2014 Annual Meeting: There were no comments heard and the recommendation was to maintain this as Developing. During the 2014 NEWMA Interim Meeting, a regulator had concern with this proposal because it could be conflicting with state and local language. Two other regulators stated that it is of ultimate importance to disclose non-confusing pricing including advertising signs, but had also concerns that it would conflict with local consumer protection ordinances. NEWMA recommended that this item be Withdrawn.

CWMA 2014 Annual Meeting: It was reported a Missouri regulator suggested eliminating the words, “in  $\frac{1}{10}$  cents” in Section 2.20.3. A Minnesota regulator supported the suggestion to eliminate the wording and explained this would allow some retailers in Minnesota who are selling specialty fuels being sold in small locations with older equipment to move the decimal point on that equipment. There was discussion that NCWM has never required this language for fuel sales. Ms. Fran Elson-Houston, Chair of the RMFD Price Posting and Computing Capabilities TG, stated that while the TG completed their work, more development should be done on this item. An industry representative stated the main focus of this item has been the issue of posted pricing on advertising signs never being lower than the pump price. A Minnesota regulator also suggested the wording “unit price per gallon or per liter” be considered. An Illinois regulator asked if there was clarification needed for the requirement of street signs. The group agreed clarification was needed. The Committee recommended the changes below and believes with these changes, the item is fully developed and recommends that it be a Voting item.

**2.20.3. Street Sign Prices and Advertising**

- (a) The unit price must be in terms of price per gallon **or liter**.
- (b) **In the event a street sign is used,** ~~When~~ the price of fuel increases, the street sign must be changed before or simultaneously when the price at the pump is changed. When the price of fuel decreases, the price at the pump must be changed before simultaneously when the street sign price is changed.

WWMA 2014 Annual Meeting: There were questions from industry and regulators about the need to have  $\frac{1}{10}$  cent pricing and advertising. One regulator said that many states already have their own laws to address street sign pricing and advertising. Several other regulators agreed and said it is not necessary to include in the Method of Sale Regulation in NIST Handbook 130. There was consensus among all stakeholders attending the 2014 WWMA meeting that this section is not needed in the NIST Handbook 130, Method of Sale Regulation. WWMA recommended that this item be Withdrawn.

2014 SWMA: The Committee heard from an industry representative that this proposal would codify that pricing will be required in  $\frac{1}{10}$  cents and that making signage and dispensers agree simultaneously would be impossible in some instances. The SWMA recommended this item be Withdrawn.

Additional letters, presentations, and data may have been part of the Committee’s consideration. To review the supporting documentation, please refer to the *Report of the 99<sup>th</sup> National Conference on Weights and Measures* (SP1193, 2014).

**232-3 V Section 2.23. Animal Bedding**

(This item was returned to Informational.)

**Source:**

NIST Office of Weights and Measures (2015)

**Purpose:**

Provide a uniform method of sale for animal bedding that will enhance the ability of consumers to make value comparisons and will ensure fair competition.

**Item Under Consideration:**

Amend the NIST Handbook 130, Method of Sale Regulation as follows:

**2.23. Animal Bedding.** —~~Packaged animal bedding of all kinds, except for baled straw, shall be sold by volume, that is, by the cubic meter, liter, or milliliter and by the cubic yard, cubic foot, or cubic inch. If the commodity is packaged in a compressed state, the quantity declaration shall include both the quantity in the compressed state and the usable quantity that can be recovered. Compressed animal bedding packages shall not include pre-compression volume statements.~~

**Example:**

~~250 mL expands to 500 mL (500 in<sup>3</sup> expands to 1000 in<sup>3</sup>).~~

(Added 1990) (Amended 2012 and 20XX)

**2.23.1. Definitions.**

- (a) Animal Bedding – Packaged animal bedding of all kinds, except for baled straw.
- (b) Usable Volume – the volume of the product that can be recovered from the package by the consumer after it is unwrapped and uncompressed.

(Added 20XX)

**2.23.2. Method of Sale.**

- (a) Packaged animal bedding shall be advertised, labeled, offered and exposed for sale and sold on the basis of the usable volume. If unit pricing is offered to retail consumers, it shall be in terms of the price per liter.
- (b) The quantity declaration shall include the terms “Usable Volume” or wording of similar import that expresses the facts, and shall be in terms of the largest whole unit of the milliliter, liter or cubic meter. A declaration may also include the quantity in terms of largest whole unit of cubic inches, cubic foot, or cubic yard only.

**Examples:**

Usable Volume 41 Liters (1.4 Cubic Feet)

Usable Volume 1.4 Cubic Feet (41 Liters)

Usable Volume 27.9 Liters (1700 Cubic Inches)

Usable Volume 113 L (4 Cubic Feet)

Usable Volume 8 Cubic Feet (226 L)

- (c) The display of pre-compression volume, compressed volume or supplementary dry measure units (e.g., dry quart, bushel) anywhere on the package is prohibited.

(Added 20XX)

**2.23.1-3. Exemption.** - Non-Consumer Packages of Animal Bedding Sold to Laboratory Animal Research Industry. – Packaged Animal Bedding consisting of granular corncobs and other dry (8 % or less moisture), pelleted, and/or non-compressible Bedding materials that are sold to commercial (non-retail) end users in the laboratory animal research industry (government, medical, university, preclinical, pharmaceutical, research, biotech, and research institutions) may be sold on the basis of weight. (Added 1990) (Amended 2012 and 20XX)

**Note: This method of sale for animal bedding shall be enforceable after January 1, 2018.**  
**(Added 20XX)**

**Background/Discussion:**

This proposal provides amendments to NIST Handbook 130, Uniform Method of Sale, Section 2.23. Animal Bedding. These changes were determined when a proposal was drafted to revise the test procedures within NIST Handbook 133, Chapter 3., Section 3.9. **Dimensional Test Procedure for Verifying the Compressed Quantity Declaration on Packages of Peat Moss and Animal Bedding**, and a new proposal was created to add **Section 3.15. Test Procedure for Verifying the Expanded Volume Declaration on Packages of Animal Bedding** (refer to Items 260-2 and 260-3).

NCWM 2015 Interim Meeting: Support was heard in favor of this proposal. It was agreed that the compressed statement is meaningless to the end users. The NIST Technical Advisor noted that if this item moved forward to remove the term compressed it would impact the language in Item 260-2, NIST Handbook 133, Section **3.9. Dimensional Test Procedure for Verifying the Compressed Quantity Declaration on Packages of Peat Moss and Animal Bedding**. The NIST Technical Advisor remarked that the background information is being reviewed by the office publication coordinator and advised that no technical changes were being made and that it would be resubmitted with NCWM Publication 16 (2015). The Committee agreed to move this forward as a Voting item.

NCWM 2015 Annual Meeting: The NIST Technical Advisor submitted the following changes to the Item under Consideration:

- added the language to Section 2.23.1.(a): **including pet or stall bedding, cat or pet litter, or simply bedding;**
- change the term “expanded volume” to read “usable volume;”
- moved the examples in Section 2.23.2.(c) to 2.23.2.(b);
- add the term **or weight** to Section 2.23.2.(c); and
- add the following: **Note: This method of sale for animal bedding shall be enforceable after January 1, 2018.**

During Open Hearings, it was discussed that adding the term “cat litter” to the definition of animal bedding may not be appropriate. It was suggested that only wood shaving and paper products be considered animal bedding under this method of sale and test procedure. Along with the method of sale for kitty litter there were questions regarding the MAV and the test procedure for cat litter. The Committee modified two areas of the Item Under Consideration:

- **2.23.1. Definitions.**  
**Animal Bedding – Packaged animal bedding of all kinds, except for baled straw. ~~any material, except for baled straw kept, offered or exposed for sale or sold for primary use as a medium for any companion or livestock animal to nest or eliminate waste, including pet or stall bedding, cat or pet litter, or simply bedding.~~**
- Section 2.23.2.(c) strike the term **or weight**.

The Committee changed the status of this item to Informational and is recommending further development of the following:

- Section 2.23.1.(b) – Review the definition of “Usable” volume for ALL types of animal bedding, including uncompressed. Substrate type products may not be the correct term for this section.
- Need to define the term “compressed form.”
- Section 2.23.2.(c) add the term “or weight” to supplemental units.
- Does the enforceable date work for manufacturers?
- Review of the test procedure (Item 260-3).

Refer to Appendix C for the Executive Summary on “Testing Packages of Animal Bedding and Peat Moss with Compressed and Expanded Volume Declarations” and additional background information.

**Regional Association Comments:**

NEWMA 2014 Interim Meeting: The L&R Chairman stated that NIST, OWM had submitted considerable information to the region for review. This is one of a number of proposals that represents a large amount of work done by NIST to provide consistent standards. An industry representative commented that he participated in the development of this proposal, and said industry has had a long-term struggle with various standards for both compressed and non-compressed packaging. He said these new procedures would allow for accurate and easier testing in the field. He indicated removal of the term “compressed” as a descriptor is important, because a consumer needs to know the usable amount of volume inside the package. These new procedures will minimize destructive testing, and will cover testing of new products in the marketplace. He strongly supports the proposal. A regulator asked if this procedure would include pelletized product. The industry representative indicated it would cover those products. Another regulator asked if compressed product would be broken up or crushed in the compressing process, and would, therefore, settle out to net a different volume. The industry representative explained that there is a certain amount of destruction, so the usable volume will generally be slightly less than the volume statement. A regulator expressed support for this item to allow for clear and easy understanding by the consumer. Another regulator asked a question about the chute design, use, and handling of various types of products during the test procedure. The industry representative explained that one of the challenges in testing volume is the amount of variability, depending on the raw material you are starting with. He further explained that the chute allowed for consistency among and between products and repeatability when testing. NEWMA forwarded the item to NCWM and recommended that it be a Voting item.

NEWMA 2015 Annual Meeting: This item was considered along with Items 260-2 and 260-3 and is considered fully developed with the editorial changes noted; the word “tentative” as it applies to MAV (maximum allowable variation) as stated in the executive summary should be stricken. Under the Method of Sale, Section 2.23.2.(c), the examples reflected shall be moved to Section 2.23.2.(b). If this item is adopted, an effective date needs to be determined for when manufacturers must use the new labeling requirements

SWMA 2014 Annual Meeting: The Committee heard an overview of the changes being suggested by NIST. The Committee also heard that the requirement to put a compressed statement on a package was unnecessary and not useful to the end user. The recoverable volume was what the customer uses. The changes also further define animal bedding. The SWMA forwarded the item to the NCWM and recommended that it be a Voting item.

CWMA 2015 Annual Meeting: An industry representative from American Wood Fiber (AWF) rose in support of the proposal. The definition change within the proposal is more inclusive and provides better clarification. Cat litter, which has traditionally been sold by weight in the past, would be sold by volume as a quantity declaration if it is not declared an exception. AWF also supports the disallowance of the word “compressed.” The reduction in the number of tests involved is also an improvement. Expanded vessel sizes will increase the accuracy of results, even though it will be a bit more onerous for inspectors. He commented that during their quality analysis testing, they found no correlation between weight and volume, so having a method that is repeatable is reassuring to the industry. The

CWMA would like clarification as to whether cat litter is exempted, and indicated this should move forward as a Voting item.

Additional letters, presentations, and data may have been part of the Committee's consideration. To review the supporting documentation, please refer to the *Report of the 99<sup>th</sup> National Conference on Weights and Measures* (SP1193, 2014).

## 232-4 V Section 2.27. Retail Sales of Natural Gas Sold as a Vehicle Fuel

(This item was returned to Committee.)

### Source:

Clean Vehicle Education Foundation (2014)

### Purpose:

Since natural gas is sold in the retail market place as compressed natural gas (CNG) to be an alternative fuel to gasoline and diesel fuel and as liquefied natural gas (LNG) to be an alternative fuel to diesel, the proposed additions and edits to NIST Handbook 130 will provide definitions for natural gas equivalents for diesel liters and diesel gallons so that end users can readily compare cost and fuel economy. At present only CNG equivalents for gasoline are included in the handbooks.

### Item Under Consideration:

Amend the NIST Handbook 130, Method of Sale Regulation as follows:

#### 2.27. Retail Sales of Natural Gas Sold as a Vehicle Fuel.

##### 2.27.1. Definitions.

**2.27.1.1. Compressed Natural Gas (CNG).** – A gaseous fuel composed primarily of methane that is suitable for compression and dispensing into a fuel storage container(s) for use as an engine fuel.

~~2.27.1.2. Gasoline Liter Equivalent (GLE). – Gasoline liter equivalent (GLE) means 0.678 kg of natural gas.~~

~~2.27.1.2.3 Gasoline Gallon Equivalent (GGE).~~ – Gasoline gallon equivalent (GGE) means 2.567 kg (5.660 lb) of compressed natural gas.

**2.27.1.3. Diesel Gallon Equivalent (DGE).** – Diesel gallon equivalent means 6.384 lb of compressed natural gas or 6.059 lb of liquefied natural gas.

**2.27.1.4. Liquefied Natural Gas (LNG).** – Natural gas which is predominantly methane that has been – 162 °C (– 260 °F) at 14.696 psia and stored in insulated cryogenic fuel storage tanks for use as an engine fuel.

##### 2.27.2. Method of Retail Sale and Dispenser Labeling.

**2.27.2.1. Method of Retail Sale.** – All compressed natural gas kept, offered, or exposed for sale and sold at retail as a vehicle fuel shall be measured in terms of mass, and indicated in the gasoline ~~liter equivalent (GLE), or gasoline~~ gallon equivalent (GGE), diesel gallon equivalent (DGE) units or mass.

**2.27.2.2. Dispenser Labeling Compressed Natural Gas.** – All retail compressed natural gas dispensers shall be labeled with the equivalent conversion factor in terms of ~~kilograms or~~ pounds (lb). The label shall be permanently and conspicuously displayed on the face of the dispenser and

shall have ~~either~~ the statement “1 Gasoline Gallon Equivalent (GGE) ~~is equal to means~~ 5.660 lb of Compressed Natural Gas” ~~or~~ “1 Diesel Gallon Equivalent (DGE) means 6.384 lb of Compressed Natural Gas” consistent with the method of sale used.

**2.27.2.3. Method of Retail Sale. – All liquefied natural gas kept, offered, or exposed for sale and sold at retail as a vehicle fuel shall be measured in mass, and indicated in diesel 1 gallon equivalent (DGE) units, or mass.**

**2.27.2.4. Dispenser Labeling of Retail Liquefied Natural Gas. – All retail liquefied natural gas dispensers shall be labeled with the equivalent conversion factor in terms of pounds (lb). The label shall be permanently and conspicuously displayed on the face of the dispenser and shall have the statement “1 Diesel Gallon Equivalent (DGE) means 6.059 lb of Liquefied Natural Gas”.**

**(Amended 20XX)**

#### **Background/Discussion:**

The gasoline gallon equivalent (GGE) unit was defined by NCWM in 1994 to allow users of compressed natural gas (CNG) vehicles to readily compare costs and fuel economy of light-duty natural gas vehicles with equivalent gasoline powered vehicles. For the medium and heavy duty natural gas vehicles in widespread use today, there is a need to officially define a unit for both Compressed Natural Gas (CNG) and Liquefied Natural Gas (LNG) (already in widespread use) allowing a comparison of cost and fuel economy with diesel powered vehicles. Natural gas is sold as a vehicle fuel as either Compressed Natural Gas (CNG) or Liquefied Natural Gas (LNG), and both products are measured in mass. The submitter stated the official definition of a DLE and a DGE will likely provide justification for California, Wisconsin, and many other states to permit retail sales of LNG for heavy-duty vehicles in these convenient units. (refer to the *Report of the 99<sup>th</sup> National Conference on Weights and Measures* [SP1193, 2014] for the mathematics justifying the specific quantity (mass) of natural gas in a DLE and DGE.)

NCWM 2014 Interim Meeting: Mr. Mahesh Albuquerque (Chair, National Gas Steering Committee [NGSC]) notified the Committee that this item is being developed by the NGSC. The Committee noted that the factor in 2.27.1.6. Liquefied Natural Gas should not read – 126.1 °C but rather – 162 °C.

The L&R Committee in responded to the NGSC’s June 10, 2014, request to change the NGSC’s March 2014 recommendation for DGE units to the following: The L&R Committee has agreed that the CNG and LNG conversion factors proposed for use in converting these gases to DGE units should be revised in the 2014 Interim Report so that their numerical values are expressed to three decimal places rather than two decimal places. These changes are reflected in the following proposed modifications within Section 2.27. Retail Sales of Natural Gas Sold as Vehicle Fuel to read: 1 Diesel Gallon Equivalent (DGE) is ~~6.380~~ 6.384 lb of Compressed Natural Gas and 1 Diesel Gallon Equivalent of Liquefied Natural Gas is ~~6.060~~ 6.059 lb.

NCWM 2014 Annual Meeting: A joint session was held with the L&R and S&T Committees to hear comments on this Item. It was noted that if the L&R did not move Item 232-3 forward then there would be no reason to proceed with Item 237-2 and S&T Item 337-2 as it appeared in the “Report of the 98<sup>th</sup> National Conference on Weights and Measures.” There was discussion regarding the term “approximately equal” in Sections 2.27.2.2. and 2.27.2.4. It was noted this term was not a measurement equivalency but equal to an energy content. It was recommended that the Committee give consideration to amend the definition and clarify the meaning. Some spoke in opposition saying this item would cause consumer confusion in the marketplace if adopted. Several members questioned where the IRS obtained the numbers that are used the IRS tax form referenced in the conversion value justification. NIST provided an alternative proposal to the item and several members believed this proposal should be taken into consideration. Since the proposal from the NGSC was not released until June 10, 2014, members felt they did not have enough time to vet the modification or the NIST proposal. The Committee reviewed numerous letters in regards to the three items being considered here.

Mr. Ethan Bogren, NGSC Chair, provided the following write up from their NGSC’s meeting on January 14, 2015.

***Natural Gas Steering Committee Update Report – January 14, 2015***

The NGSC has been working diligently at achieving a compromise proposal regarding the sale of CNG/LNG as an alternative motor fuel. While the group has found success in establishing a consensus opinion in many aspects of the regulations, the group remains divided as to what unit of measure should be used for primary method of sale.

As you all know, there has been a proposal submitted urging NCWM to adopt gallon equivalent units (GGE/DGE) as the primary method of sale for natural gas products to be used as an alternative motor fuel. There has been a feeling by many members of NCWM that this would be considered a diversion from the customary units in which commodities are sold in the United States causing concern.

Since a consensus regarding the units used for the primary method of sale for natural gas products was unable to be achieved, the NGSC is prepared to submit two proposals to the L&R and S&T Committees for comment and review. It was agreed by NGSC members that this was the only fair way to represent the group as a whole.

While both proposals have many similarities, I would like to summarize the major differences regarding the method of sale as it pertains to each document.

**Volume Equivalent Compromise Version:** CNG/LNG shall be measured in mass and indicated in gallon equivalent units unless the weights and measures official having jurisdiction mandates otherwise through local regulation. This would make GGE/DGE units the only unit of quantity required to be displayed on the dispenser during a retail transaction.

**Mass Compromise Version:** CNG/LNG shall be measured in mass and indicated in mass. The display of supplemental information would also be permitted on the dispenser. This would allow GGE/DGE units to be indicated on the dispenser display face as long as it is stated the GGE/DGE units are for value comparison purposes only.

There is a willingness to accept equivalent units for advertising purposes such as street signs.

The NGSC is confident that a compromise will be found with the guidance of the S&T and L&R Committees. Along with input coming from the floor during Open Hearings during the NCWM Interim Meeting a sense of which proposal best represents the body of the National Conference of Weights & Measures may be determined.

NCWM 2015 Interim Meeting: A joint session was held with the L&R and S&T Committees to hear this Item along with Item 237-1 of the L&R report and S&T Item 337-1. (Documentation for the S&T Item 337-1 can be found within the S&T report). Two proposals were addressed. Proposal One, titled “The Volume Equivalent Compromise” requires natural gas to be measured in mass and indicated in equivalent gallon units or mass. Proposal Two, titled “The Mass Compromise Version” would require natural gas to be measured and indicated in mass with supplemental equivalent information to be displayed on the dispenser for value comparison.

***Proposal One, Volume Equivalent Compromise Version*** was supported by industry representatives and several weights and measures officials. Some reasons for supporting Proposal One is it will cause less consumer confusion. Having one method of sale that consumers are currently familiar with allows them to make value comparisons at the pump and quickly compare street signage with various stations. It would be costly to manufacture dispensers that can indicate in both mass and equivalent gallons.

***Proposal Two, Mass Compromise Version*** was supported by numerous weights and measures officials who favor a “traceable unit.” Equivalent values are not NIST traceable units of measurement. The equipment currently is able to indicate in mass units. There are several products that allow for supplemental information to be posted (e.g., paint and fertilizer). Natural gas composition fluctuates and the equivalent values have not been validated. With new fuels being developed, the correct decision needs to be made on this matter, because it may affect future proposals brought before the Conference. The NIST S&T Technical Advisor requested that FALS review the references and data that was used determine the values on the equivalent units. The FALS has agreed to put together a WG and provide additional feedback on this area.

The L&R Committee agreed to move Proposal One, “Volume Equivalent Compromise” version with revisions as addressed during the NGSC work session and Open Hearings. The Committee modified the language in Section 2.27.2.1. and 2.27.2.3. to add the language “or mass” to the last sentence in each section and moved this forward as a Voting item.

**2.27.2.1. Method of Retail Sale.** – All **compressed** natural gas kept, offered, or exposed for sale and sold at retail as a vehicle fuel shall be **measured** in terms of **mass, and indicated in** the gasoline liter equivalent (GLE), ~~or~~ gasoline gallon equivalent (GGE), **diesel liter equivalent (DLE), or diesel gallon equivalent (DGE) units, or mass.**

**2.27.2.3. Method of Retail Sale.** – **All liquefied natural gas kept, offered, or exposed for sale and sold at retail as a vehicle fuel shall be measured in mass, and indicated in diesel liter equivalent (DLE), or diesel gallon equivalent (DGE) units, or mass.**

2015 NCWM Annual Meeting: A joint session was held with the L&R and S&T Committees to hear this item along with Item 237-1 of the L&R report and S&T Item 337-1. (Documentation for the S&T Item 337-1 can be found within the S&T Committee report.) Mr. Matthew Curran (FALS Chair) provided the following modifications to the language as it appeared in NCWM Publication 16 (2015):

**Under 2.27.1. Definitions** (note renumbering of sections will be done editorially by NIST):

- Delete in its entirety Section 2.27.1.2. Gasoline Liter Equivalent (GLE).
- Under 2.27.1.3. remove metric equivalent 2.567 kg.
- Delete in its entirety Section 2.27.1.4. Diesel Liter Equivalent (DLE).

**Under 2.27.2. Method of Retail Sale and Dispenser Labeling:**

- Under this section strike the term “is equal to” and replace with “means.”
- Under 2.27.2.1. strike the terms equivalent (GLE) or gasoline. Strike diesel liter equivalent (DLE).
- Under 2.27.2.2. strike the term “kilogram.” Strike “1 Gasoline Liter Equivalent (GLE) is equal to means 0.678 kg of Natural Gas.”
- Under 2.27.2.3. strike the term “liter equivalent (DLE), diesel.”
- Under 2.27.2.4. strike the term “kilogram (kg) or”. Strike **“1 Diesel Liter Equivalent (DLE) is equal to means 0.726 kg of Liquefied Natural Gas” or**. In the last sentence strike **“consistent with the method of sale used.”** Change the term and to ‘or’ **Compressed Natural Gas” and or “1 Diesel Gallon Equivalent (DGE).**

The Committee acknowledged receiving letters in support of this proposal and that the majority of comments made during the Open Hearings were also in support of the proposal. It was noted the Committee should consider measurement principles, value comparisons, and traceability (**Note:** equivalents are not traceable) during its analysis. A TG under the FALS is currently looking at the equivalent numbers. It was also questioned whether both proposals were reviewed and considered in detail. A corrected document was received for Appendix A, Background and Justification for Handbook 130, Definition of “Diesel Gallon Equivalent (DGE)” of Compressed Natural Gas (CNG) and Liquefied Natural Gas (LNG) as a Vehicular Fuel.

A majority of the Committee believe that the changes submitted during Open Hearings are fully developed and will align with language proposed in S&T 337-1. The language changes support clarifying that two types of natural gas exist as a motor vehicle fuel [compressed and liquefied]. Additionally, the proposal makes it clear that the method of sale for compressed natural gas may be either GGE, DGE, or mass, and for liquefied natural gas the method of sale



may be DGE or mass; however, all natural gas sold as a vehicle fuel shall be measured in mass. This Item along with 237-1 and S&T Item 337-1 received a split vote, therefore it was returned to the Committee.

**Regional Association Comments:**

**CWMA 2014 Annual Meeting:** This received numerous comments from both industry representatives and regulators. No new issues surfaced, and based on the number of comments heard, most of the comments pointed toward the need to keep the method of sale in mass, and that continued utilization of equivalencies is not in keeping with appropriate metrological practices. However, a supplemental marketing statement similar to the proposal developed by NIST would be useful to consumers. Mr. Ronald Hayes, who serves on the NGSC, indicated that the group met via teleconference in the week previous to the CWMA meeting and continues to work through this issue. Mr. Constantine Cotsoradis, Flint Hills Resources, presented an amendment to the Method of Sale section, which was forwarded to the Steering Committee for their consideration. Due to the contentious nature of this issue, further work is merited by the metrological community and industry. The Committee believes there is no evidence that suggests equivalency measures are appropriate for a method of sale. The Committee believes there is merit for consideration in the newly proposed verbiage because retail sales occur in other locations other than a retail dispenser. The Committee also recognizes the importance of consumer understanding and acceptance, and believes this issue needs to continue development through the NGSC.

**CWMA 2015 Annual Meeting:** Discussions were robust and reflected the same positions and information as prior meetings and dialogue. The Committee believes the item is fully developed. A Vote of acclamation was too close to determine, so the Chair opted for a show of hands, followed by a standing Vote. The item passed with a Vote of 18 for and 17 opposed.

**WWMA 2014 Annual Meeting:** Mr. Mahesh Albuquerque, Chairman of the NGSC, provided an update from the NGSC September 4, 2014, meeting. The NGSC is reviewing: natural gas dispenser labeling requirements; refining the current proposal based upon feedback including data from the CRC regarding sampling to determine the average natural gas BTU content and data from the American Transportation Research Institute regarding the average BTU content of diesel fuel; and drafting an alternative proposal for the 2015 Interim Meeting.

WWMA recommended that NCWM consider all alternatives, including the NIST alternate proposal. However, if the NCWM determines that DGE/DLE is an appropriate method of sale for natural gas, the WWMA recommended that the sale of CNG at high-flow retail motor fuel dispensers be in units of DGE/DLE only, and at low-flow CNG retail motor fuel dispensers, allow GGE/GLE only. The WWMA believes it would be confusing for drivers of light duty CNG vehicles to see prices expressed in both GGE and DGE. Also, the WWMA suggested the NCWM consider a customer activated selectable display for indication at the dispenser (GGE/DGE/lb or GLE/DLE/kg). The WWMA recommended striking the word “approximately” from Sections 2.27.2.2. and 2.27.2.4. because an approximate amount cannot be conclusively verified. Several regulators offered comments, both in support and in opposition, similar to those received at previous meetings. Five regulators supported the NIST alternative. One regulator commented that other fuel marketers may seek a gallon-equivalent for their fuels (e.g., electricity).

During the WWMA voting session, one regulator noted that the WWMA had previously recommended withdrawing all agenda items relating to DGE/DLE, and requested the L&R Committee poll the voting members to see how many are in support of the continued use of equivalent units. The voting results were 23 in opposition to the use of equivalent units, and 12 in support of using equivalent units “going forward”. WWMA recommended this remain an Informational item.

**NEWMA 2014 Interim Meeting:** NEWMA recommended that the NGSC consider that the Method of Sale be changed to mass and that the NIST proposal to modify Section 3.37, Mass Flow Meters in NIST Handbook 44 (2014 edition) be considered. (The draft NIST proposal is on the NEWMA Web Site as a supporting document.) NEWMA recommended that Item 237-1 and also Item 337-1 from the S&T agenda be Informational items pending final language from the NGSC at the NCWM 2015 Interim Meeting.

**NEWMA 2015 Annual Meeting:** There was concern this change further confuses consumers. The Committee believes that consumers are adaptable to the marketplace. The Committee is anxious to learn more about the work being done on verifiable equivalency conversion factors being worked on by the Natural Gas Conversion WG. A motion was

made to continue this as a Voting item along with agenda Item 237-1 and S&T agenda Item 337-1. At the time of the vote there was no second received on the motion. Therefore, the item was returned to the Committees.

SWMA 2014 Meeting: The Committee heard from Dr. Matthew Curran with the Natural Gas Steering Committee who indicated they were still working on the item. The SWMA recommended this be an Informational item.

Additional letters, presentations, and data may have been part of the Committee's consideration. To review the supporting documentation, please refer to the *Report of the 99<sup>th</sup> National Conference on Weights and Measures* (SP1193, 2014).

## **237 NIST HANDBOOK 130 – UNIFORM ENGINE FUELS AND AUTOMOTIVE LUBRICANTS REGULATION**

### **237-1 V Section 1. 1.36. Liquefied Natural Gas (LNG) and Section 3.11. Compressed Natural Gas (CNG)**

(This item was returned to Committee.)

**Source:**

Clean Vehicle Education Foundation (2013)

**Purpose:**

Enable consumers to make cost and fuel economy comparisons between diesel fuel and natural gas.

**Item Under Consideration:** Amend NIST Handbook 130, Uniform Engine Fuels and Automotive Lubricants Regulation as follows:

#### **Section 1. Definitions**

**1.36. Liquefied Natural Gas (LNG).** – Natural gas that has been liquefied at – 162 °C (– ~~259~~260 °F) and stored in insulated cryogenic tanks for use as an engine fuel.

#### **Section 3. Classification and Method of Sale of Petroleum Products**

##### **3.11. Compressed Natural Gas (CNG).**

**3.11.1. How Compressed Natural Gas is to be Identified.** – For the purposes of this regulation, compressed natural gas shall be identified by the term “Compressed Natural Gas” or “CNG.”

##### **3.11.2. Retail Sales of Compressed Natural Gas Sold as a Vehicle Fuel.**

~~**3.11.2.1. Method of Retail Sale.** – All CNG kept, offered, or exposed for sale or sold at retail as a vehicle fuel shall be in terms of the gasoline liter equivalent (GLE) gasoline gallon equivalent (GGE).~~

##### **3.11.2.2.1. Retail Dispenser Labeling.**

**3.11.2.2.1.1. Identification of Product.** – Each retail dispenser of CNG shall be labeled as “Compressed Natural Gas.”

~~**3.11.2.2.2. Conversion Factor.** – All retail CNG dispensers shall be labeled with the conversion factor in terms of kilograms or pounds. The label shall be permanently and conspicuously displayed on the face of the dispenser and shall have either the statements “1~~

~~Gasoline Liter Equivalent (GLE) is equal to 0.678 kg of Natural Gas “1 Gasoline Gallon Equivalent (GGE) is equal to 5.660 lb of Natural Gas consistent with the method of sale used.~~

**3.11.2.21.32. Pressure.** – CNG is dispensed into vehicle fuel containers with working pressures of ~~16 574 kPa~~, 20 684 kPa (**3000 psi**), or 24 821 kPa (**3600 psi**). The dispenser shall be labeled ~~16 574 kPa~~, 20 684 kPa (**3000 psi**), or 24 821 kPa (**3600 psi**) corresponding to the pressure of the CNG dispensed by each fueling hose.

**3.11.2.21.43. NFPA Labeling.** – NFPA Labeling requirements also apply. (Refer to NFPA 52.)

**3.11.3. Nozzle Requirements for CNG.** – CNG fueling nozzles shall comply with ANSI/AGA/CGA NGV 1.

#### **Background/Discussion:**

The gasoline gallon equivalent (GGE) unit was defined by NCWM in 1994 to allow users of natural gas vehicles to readily compare costs and fuel economy of light-duty compressed natural gas vehicles with equivalent gasoline powered vehicles. For the medium and heavy duty natural gas vehicles in widespread use today, there is a need to officially define a unit (already in widespread use) allowing a comparison of cost and fuel economy with diesel powered vehicles. The submitter stated that the official definition of a DLE and a DGE will likely provide justification for California, Wisconsin and many other states to permit retail sales of CNG for heavy-duty vehicles in these convenient units. The mathematics justifying the specific quantity (mass) of compressed natural gas in a DLE and DGE (please refer to the Report of the 99th National Conference on Weights and Measures (SP1193, 2014).

NCWM 2014 Interim Meeting: Mr. Albuquerque (Chair, National Gas Steering Committee) notified the Committee that this item was actively being developed by the National Gas Steering Committee.

The L&R Committee responded to the NGSC’s June 10, 2014, request to change the NGSC’s March 2014 recommendation for DGE units. The L&R Committee agreed that the CNG and LNG conversion factors proposed for use in converting these gases to DGE units should be revised in the 2014 Interim Report so that their numerical values are expressed to three decimal places rather than two decimal places. These changes are reflected in the following proposed modifications to Section 1. Definitions 1.XX, and to the proposed new definition for “diesel gallon equivalent” to read: 1 Diesel Gallon Equivalent (DGE) is ~~6.380~~ 6.384 lb of Compressed Natural Gas and 1 Diesel Gallon Equivalent of Liquefied Natural Gas is ~~6.060~~ 6.059 lb.

NCWM 2014 Annual Meeting: A joint session was held with L&R and S&T Committees to hear comments on this Item. It was noted that if the L&R did not move forward the Item 232-3 there would be no reason to proceed with Item 237-2 and S&T Item 337-2 as it appeared in the “Report of the 98th National Conference on Weights and Measures.” There was discussion regarding the term “approximately equal” in Sections 2.27.2.2. and 2.27.2.4. It was noted this term was not a measurement equivalency but equal to in energy content. It was recommended that the Committee give consideration to amend the definition and clarify the meaning. Some spoke in opposition that this Item would cause consumer confusion in the marketplace, if adopted. Several members questioned where IRS obtained the numbers that are used the IRS tax form. NIST provided an alternative proposal and several members believed this proposal should be taken into consideration. Since the proposal from the NGSC was not released until June 10, 2014, members felt they did not have enough time to vet the modification or the NIST proposal. The Committee reviewed numerous letters in support of all the Items that reflect this issue.

#### **March 2014 Natural Gas Steering Committee Report to the L&R and S&T Committees:**

The Natural Gas Steering Committee (NGSC) was formed in July 2013 to help understand and educate the NCWM membership regarding the technical issues surrounding the proposed changes to NIST Handbook 44 and NIST Handbook 130 submitted by the Clean Vehicle Education Foundation (CVEF), the anticipated impact of the proposed changes, and issues related to implementation requirements when compressed natural gas (CNG) and liquefied natural gas (LNG) are dispensed and sold as a retail engine fuel in gallon equivalent units.

NCWM Interim Meeting in January 2014: Mr. Mahesh Albuquerque, Chair of the NGSC, provided the S&T and L&R Committees with an update from the NGSC, including proposed revisions to the proposals submitted by the

CVEF. The NGSC heard comments from the floor related to the proposed revisions and requested additional time to further develop its recommendations. The S&T and L&R Committees agreed to allow the NGSC additional time to meet and develop alternative proposals to those on the S&T and L&R Committees January 2014 agendas, with the expectation that the NGSC recommendations would be ready for inclusion in NCWM Publication 16, and moved forward as a Voting Item at the July 2014 NCWM Annual Meeting.

**Summary of NGSC Meeting Discussions:**

The NGSC met weekly following the January 2014 Interim Meeting and focused on modifying the Clean Vehicle Education Foundation (CVEF) 2013 proposals for the recognition of diesel gallon equivalent (DGE) units for CNG/LNG dispenser indications and the method of sale for these two natural gas alternative engine fuels. The NGSC reviewed multiple modifications to those proposals including:

- limiting sales to a single unit of mass measurement enforceable by 2016;
- requiring indications in mass and gasoline and diesel gallon equivalents, while phasing in mass only units;
- require sale by mass as the primary means, but allow for the simultaneous display of volume equivalent units, so long as the purchaser always had access to the mass (traceable) measurement; and
- a proposal from NIST, OWM which would allow the posting of supplemental information to assist consumers in making value comparisons and for use by taxation/other agencies, but requiring the phase in of indications in mass.

The NGSC received:

- input from Department of Energy (DOE) on the latest edition of the DOE “Transportation Energy Data Book”: edition 32, July 2013 available on the Oak Ridge National Laboratory website at: <http://cta.ornl.gov/data/index.shtml>;
- updates from CNG (3) and LNG (1) dispenser manufacturers indicating their dispensing systems comply with the requirements in the handbooks, and have the capability to indicate a sale in a single unit of measurement, and any further input on adding displays to the cabinet for additional units would require further cost analysis; while one original equipment manufacturer indicated use of their LNG RMFD in a fleet operation where indications are only in the DGE; and
- feedback from committee members related to the pros and cons of requiring the indication of sale in mass or gallon equivalent units, including traceability, equipment capabilities, marketplace considerations, and units used by state and federal agencies.

Also noted in the NGSC discussions were:

- how a gallon equivalent unit is derived using energy content and how the gallon equivalent is defined and measured in terms of mass, not volume;
- for the last 20 years, NIST Handbook 44 and NIST Handbook 130 have required all dispensing equipment to indicate deliveries of natural gas in GGE units to consumers and in mass units for inspection and testing purposes. CNG RMFD equipment in the most states comply with the requirements in the handbooks;
- international practices for indicating CNG and LNG engine fuel deliveries are predominantly mass; Canada requires LNG indications in the kilogram and the corresponding OIML R 139 “Compressed gaseous fuel measuring systems for vehicles” standard requires indication of the measured gas in mass;
- the variations in engine efficiency relative to a single conversion factor based on an averaged energy content for LNG and the primary focus of the driving public and fleets on mileage rather than petroleum products no longer used to fuel their vehicles;

- the work ahead over the next year by ASTM Committees to develop current CNG and LNG fuel quality standards which will need to be referenced in NIST Handbook 130;
- differences in the measurement of the gallon and kilogram – since the gallon is a volume measurement and not an energy measurement, and the NIST Handbook 44, Mass Flow Meters Code includes a requirement for volume-measuring devices with ATC used in natural gas applications to be equipped with an automatic means to make corrections, if the devices is affected by changes in the properties of the product; it was also noted that U.S. gasoline and diesel dispensers are not required to have ATC; whereas ATC does occur in sales at the wholesale level;
- how traceability applies to the measurement results at each level of the custody chain (to include the determination of the uncertainty of all calibrations and use of an appropriate unit of measurement); and
- the capabilities of equipment in the marketplace.

A DOE representative supported the use of gallon equivalents, and pointed out that they are used in the DOE Transportation Energy Data Book. The DOE representative also pointed out that other federal agencies including the IRS were requiring use of gallon equivalent units for reporting.

Industry representatives on the NGSC indicated that they are actively campaigning to their state and federal offices, encouraging each government branch to recognize sales of CNG and LNG in gasoline and diesel volume equivalent units. Industry sectors represented on the NGSC indicated that their customers are satisfied with the averaged fuel energy values that correspond to the conversion factors for CNG and LNG, with only one exception. The exception was a truck stop chain indicating their customers would be amenable to a single conversion factor for both fuels. The CVEF also provided a comparison of GTI's 1992 study results and preliminary data from a 2013 study. The CVEF reported the constituents in natural gas as basically unchanged over 21 years since the NCWM first recognized the GGE. Industry unanimously opposed a recommendation for phasing in mass as the only unit of measurement, noting also that U.S. drivers would be confused by SI units while acknowledging that the United States is in the minority of countries whereby delivery and sales are by equivalent units. At the conclusion of the NGSC deliberations, NGVAmerica provided the following statement:

“One of the major advantages of the proposal as currently drafted with inclusion of the DGE and GGE units for natural gas is that this is a proposal that the natural gas industry can support. It further recognizes what is already the preferred practice for how natural gas is measured and dispensed. The latest proposal with DGE and GGE units provides a pathway forward toward a national consensus approach. If the proposal were to instead require use of kilograms or even pounds as the primary method of sale, industry would not support that proposal and likely would strongly oppose it this summer if NCWM were to consider it as a voting issue. Also, if NCWM finalizes on a standard that does not include DGE or GGE, industry is committed to pursuing adoption of an alternative standard on a state by state basis, which could lead to different treatment across the country. Several states have already introduced legislation to recognize the DGE standard (CA, IL, MO, and VA) and I expect more will do so later this year. And you know Colorado and Arkansas already have put in place standards that recognize the DGE units.”

#### **NGSC Recommendations:**

After consideration of all of the above, the NGSC recommends alternate proposals to the L&R and S&T Committee Agenda Items which further modify and consolidate the Clean Vehicle Education Foundation 2013 proposals to include:

- 1) requirements for measurement in mass and indication in gallon equivalent units (NIST Handbook 44 paragraphs S.1.3.1.1. and S.1.3.1.2.; and NIST Handbook 130 paragraphs 3.11.2.1. and 3.12.2.1.);
- 2) posting of a label that has both the GGE and DGE or the GLE and DLE for CNG applications (NIST Handbook 44 paragraphs S.5.2., S.5.3., UR.3.1.1., and UR.3.1.2; and NIST Handbook 130 paragraphs 3.11.2.2.2. and 3.12.2.2.2.);

- 3) expression of all equivalent conversion factors expressed in mass units to three significant places beyond the decimal point for consistency (NIST Handbook 44 paragraphs S.5.2., S.5.3., UR.3.1.1., and UR.3.1.2 and Appendix D and NIST Handbook 130 Section 1, paragraphs 3.11.2.2.2. and 3.12.2.2.2.);
- 4) correction of the temperatures in the LNG definition (NIST Handbook 130 Section 1);
- 5) addition of 16 CFR Part 309 for CNG automotive fuel rating (NIST Handbook 130 paragraph 3.11.2.2.5.); and
- 6) reference to NFPA 52 (NIST Handbook 130 paragraph 3.12.2.2.4.)

With regards to NIST Handbook 44 the NGSC recommends withdrawing S&T Agenda Items 337-1 and 337-4 and the consolidation of Agenda Items 337-2, 337-3, and 337-5 into a newly revised single Voting Item designated as Item 337-2 as it appeared in the “Report of the 98th National Conference on Weights and Measures.” The NGSC also recommends further modifications to corresponding NIST Handbook 130 proposals to align the definitions of related terms and method of sale with definitions, indicated delivery and dispenser labeling requirements being proposed for NIST Handbook 44.

With regards to NIST Handbook 44, the NGSC also recommends consideration of a new Developing item addressing proposed changes to Paragraph S.3.6 Automatic Density Correction designated as Item 360-4. This new proposal is consistent with the NGSC decision to encourage further work beyond the current scope of their work on the CVEF’s proposals to fully address all LNG applications.

Representatives of the NGSC and the S&T and L&R Committees met in March 2014, all agreed on the course of action outlined above.

Additional Contacts: Clean Energy, Seal Beach, CA, NGVAmerica, Washington, DC, Clean Vehicle Education Foundation, Acworth, GA. Regional Association Comments: (Fall 2013 Input on the Committee’s 2014 Interim Agenda Items 337-1 through 337-5)

With regards to NIST Handbook 130 the NGSC recommends Withdrawing L&R Agenda Items 237-1 and the consolidation of Agenda Items 237-2, 237-3, and 237-5 into newly revised single Voting item designated as 237-1 in the “Report of the 98th National Conference on Weights and Measures.”

NCWM 2015 Interim Meeting: A joint session was held with the L&R and S&T Committees to discuss Item 232-4 of the L&R report. Documentation for the S&T Item 337-1 can be found within the S&T report. Two proposals were addressed. Proposal One, titled “the Volume Equivalent Compromise” requires natural gas to be measured in mass and indicated in equivalent gallon units or mass. The Second Proposal titled, “The Mass Compromise Version” would require natural gas to be measured and indicated in mass with supplemental equivalent information to be displayed on the dispenser for value comparison.

Proposal One was supported by industry representatives and several weights and measures officials. Some reasons for supporting Proposal One is it will cause less consumer confusion. Having one method of sale that consumers are currently familiar with allows them to make value comparisons at the pump and quickly compare street signage with various stations. It would be costly to manufacturer dispensers that can indicate in both mass and equivalent gallons.

The Second Proposal was supported by numerous weights and measures officials who favor a traceable unit. Equivalent values are not NIST traceable units of measurement. The equipment currently is able to indicate in mass units. Currently there are several products that allow for supplemental information to be posted (e.g., paint and fertilizer.) Natural gas composition fluctuates and the equivalent values have not been validated. With new fuels being developed, the correct decision needs to be made on this matter because it may affect future proposals brought before the Conference. The NIST Technical Advisor requested that the FALS review the references and data that is used for the conversion values on the equivalent units. The FALS has agreed to put together a WG and provide additional feedback on this area. After solicitation for volunteers, a mixed WG comprised of FALS and NGSC members was formed and is currently functioning under the NGSC. However, should the NGSC dissolve prior to completion of this review, the WG would move under FALS.

Mr. Ethan Bogren, NGSC Chair, provided the following write up from their NGSC’s meeting on January 14, 2015.

**Natural Gas Steering Committee Update Report – January 14, 2015:**

The NGSC has been working diligently at achieving a compromise proposal regarding the sale of CNG/LNG as an alternative motor fuel. While the group has found success in establishing a consensus opinion in many aspects of the regulations, the group remains divided as to what unit of measure should be used for primary method of sale.

As you all know, there has been a proposal submitted urging NCWM to adopt gallon equivalent units (GGE/DGE) as the primary method of sale for natural gas products to be used as an alternative motor fuel. There has been a feeling by many members of NCWM that this would be considered a diversion from the customary units in which commodities are sold in the United States causing concern.

Since a consensus regarding the units used for the primary method of sale for natural gas products was unable to be achieved, the NGSC is prepared to submit two proposals to the L&R and S&T Committees for comment and review. It was agreed by NGSC members that this was the only fair way to represent the group as a whole.

While both proposals have many similarities, I would like to summarize the major differences regarding the method of sale as it pertains to each document.

**Volume Equivalent Compromise Version:** CNG/LNG shall be measured in mass and indicated in gallon equivalent units unless the weights and measures official having jurisdiction mandates otherwise through local regulation. This would make GGE/DGE units the only unit of quantity required to be displayed on the dispenser during a retail transaction.

**Mass Compromise Version:** CNG/LNG shall be measured in mass and indicated in mass. The display of supplemental information would also be permitted on the dispenser. This would allow GGE/DGE units to be indicated on the dispenser display face as long as it is stated the GGE/DGE units are for value comparison purposes only.

There is a willingness to accept equivalent units for advertising purposes such as street signs.

The NGSC is confident a compromise will be found with the guidance of the S&T and L&R Committees. Along with input coming from the floor during Open Hearings during the NCWM Interim Meeting a sense of which proposal best represents the body of the National Conference of Weights and Measures may be determined.

NCWM 2015 Interim Meeting: A joint session was held with the L&R and S&T Committees to hear comments on this item along with Item 232-4 of the L&R report. Documentation for the S&T Item 337-1 can be found within the S&T Committee report. Proposal One, titled “The Volume Equivalent Compromise” requires natural gas to be measured in mass and indicated in equivalent gallon units or mass. Proposal One was supported by industry representatives and several weights and measures officials. Reasons for supporting Proposal One is it will cause less consumer confusion. Having one method of sale that consumers are currently familiar with allows them to make value comparisons at the pump and quickly compare street signage with various stations. It would be costly to manufacturer dispensers that can indicate in both mass and equivalent gallons.

Proposal Two titled, “The Mass Compromise Version,” would require natural gas to be measured and indicated in mass with supplemental equivalent information to be displayed on the dispenser for value comparison. Proposal Two was supported by numerous weights and measures officials who favor a traceable unit. Equivalent values are not NIST traceable units of measurement. The equipment currently is able to indicate in mass units. There are several products that allow for supplemental information to be posted (e.g., paint and fertilizer). Natural gas composition fluctuates and the equivalent values have not been validated. With new fuels being developed, the correct decision needs to be made on this matter because it may affect future proposals brought before the Conference. A NIST S&T Technical Advisor requested FALS review the references and data that is used for the values on the equivalent units. The FALS has agreed to put together a WG and provide additional feedback on this area.

Proposal Two, “The Mass Compromise” recommended the following:

**1.XX. Diesel Gallon Equivalent (DGE). – Diesel Gallon Equivalent (DGE) means 6.384 lb of compressed natural gas or 6.059 lb of liquefied natural gas.**

**1.25. Gasoline Gallon Equivalent (GGE).** – ~~Gasoline Gallon~~ Equivalent (**GGE**) ~~means to 2.567 kg~~ (5.660 lb) of **compressed** natural gas.

~~**1.26. Gasoline Liter Equivalent (GLE).** – Equivalent to 0.678 kg (1.495 lb) of natural gas.~~

**1.35. Liquefied Natural Gas (LNG).** – Natural gas that has been liquefied at ~~–126.1~~ **162** °C (–~~259~~ **260** °F) and stored in insulated cryogenic tanks for use as an engine fuel.

### **3.11. Compressed Natural Gas (CNG).**

**3.11.1. How Compressed Natural Gas is to be Identified.** – For the purposes of this regulation, compressed natural gas shall be identified by the term “Compressed Natural Gas” or “CNG.”

#### **3.11.2. Retail Sales of Compressed Natural Gas Sold as a Vehicle Fuel.**

**3.11.2.1. Method of Retail Sale.** – All CNG kept, offered, or exposed for sale or sold at retail as a vehicle fuel shall be **either** in terms of the gasoline ~~liter equivalent (GLE) or gasoline~~ gallon equivalent (GGE), **the diesel gallon equivalent (DGE), or in mass if required by the weights and measures authority having jurisdiction.**

#### **3.11.2.2. Retail Dispenser Labeling.**

**3.11.2.2.1. Identification of Product.** – Each retail dispenser of CNG shall be labeled as “Compressed Natural Gas.”

**3.11.2.2.2. Conversion Factor.** – All retail CNG dispensers shall be labeled with the conversion factor in terms of ~~kilograms or~~ pounds. The label shall be permanently and conspicuously displayed on the face of the dispenser and shall have either the statement **“1 Gasoline Liter Equivalent (GLE) is equal to 0.678 kg of Natural Gas” or “1 Gasoline Gallon Equivalent (GGE) is equal to means 5.660 lb of Compressed Natural Gas,” or “1 Diesel Gallon Equivalent (DGE) means 6.384 lb of Compressed Natural Gas”,** consistent with the method of sale used.

**3.11.2.2.3. Pressure.** – CNG is dispensed into vehicle fuel containers with working pressures of ~~16 574 kPa,~~ 20 684 kPa (**3,000 psig**), or 24 821 kPa (**3,600 psig**). The dispenser shall be labeled ~~16 574 kPa,~~ 20 684 kPa (**3,000 psig**), or 24 821 kPa (**3,600 psig**) corresponding to the pressure of the CNG dispensed by each fueling hose.

**3.11.2.2.4. NFPA Labeling.** – NFPA Labeling requirements also apply. (Refer to NFPA 52.)

**3.11.3. Nozzle Requirements for CNG.** – CNG fueling nozzles shall comply with ANSI/AGA/CGA NGV 1.

### **3.12. Liquefied Natural Gas (LNG).**

**3.12.1. How Liquefied Natural Gas is to be Identified.** – For the purposes of this regulation, liquefied natural gas shall be identified by the term “Liquefied Natural Gas” or “LNG.”

#### **3.12.2. Retail Sales of Liquefied Natural Gas Sold as a Vehicle Fuel.**

**3.12.2.1. Method of Retail Sale.** – All LNG kept, offered, or exposed for sale or sold at retail as a vehicle fuel shall be **in terms of the diesel gallon equivalent (DGE), or in mass if required by the weights and measures authority having jurisdiction.**



**3.12.23. Labeling of Retail Dispensers of Liquefied Natural Gas Sold as a Vehicle Fuel Labeling.**

**3.12.23.1. Identification of Product.** – Each retail dispenser of LNG shall be labeled as “Liquefied Natural Gas.”

**3.12.3.2. Conversion Factor.** – **All retail LNG dispensers shall be labeled with the conversion factor in terms of pounds. The label shall be permanently and conspicuously displayed on the face of the dispenser and shall have the statement “1 Diesel Gallon Equivalent (DGE) means 6.059 lb of Liquefied Natural Gas”.**

**~~3.12.23.23.~~ Automotive Fuel Rating.** – LNG automotive fuel shall be labeled with its automotive fuel rating in accordance with 16 CFR Part 306.

**~~3.12.23.34.~~ NFPA Labeling.** – NFPA Labeling requirements also apply. (Refer to NFPA ~~5752.~~)

Based upon information from the NGSC and information in Proposal One “Volume Equivalent Compromise Version” the Committee removed the following language that appeared in NCWM Publication 15 (2015) from the Item for Consideration:

**Section 1. Definitions**

**1.XX. Diesel Gallon Equivalent (DGE).** – **means 6.384 lb of compressed natural gas or 6.059 lb of liquefied natural gas.**

**1.XX. Diesel Liter Equivalent (DLE).** – **means 0.765 kg of compressed natural gas or 0.726 kg of liquefied natural gas.**

**1.26. Gasoline Gallon Equivalent (GGE).** – **means** 2.567 kg (5.660 lb) of **compressed** natural gas.

**1.27. Gasoline Liter Equivalent (GLE).** – **means** 0.678 kg (1.495 lb) of **compressed** natural gas.

Based upon information from the NGSC the Committee deleted Section 3.11.2.1. Method of Retail Sale and Section 3.11.2.2.2. Conversion Factor, and the entire Section for 3.12. Liquefied Natural Gas (LNG) from the Item Under Consideration in the 2015 NCWM Interim Report. The Committee is recommending it move forward as a Voting Item.

**Section 3. Classification and Method of Sale of Petroleum Products**

**3.11.2.1. Method of Retail Sale.** – All CNG kept, offered, or exposed for sale or sold at retail as a vehicle fuel shall be **measured** in terms of **mass, and indicated in** the gasoline liter equivalent (GLE), gasoline gallon equivalent (GGE), **diesel liter equivalent (DLE), or diesel gallon equivalent (DGE) units.**

**3.11.2.2.2. Conversion Factor.** – All retail CNG dispensers shall be labeled with the **equivalent** conversion factor in terms of kilograms or pounds. The label shall be permanently and conspicuously displayed on the face of the dispenser and shall have either the statements “1 Gasoline Liter Equivalent (GLE) is **Approximately Equal** to 0.678 kg of Natural Gas” **and “1 Diesel Liter Equivalent (DLE) is Approximately Equal to 0.765 kg of Compressed Natural Gas”** or **the statements** “1 Gasoline Gallon Equivalent (GGE) is **Approximately Equal** to 5.660 lb of **Compressed Natural Gas**” **and “1 Diesel Gallon Equivalent (DGE) is Approximately Equal to 6.384 lb of Compressed Natural Gas”** consistent with the method of sale used.

**3.11.2.2.5. Automotive Fuel Rating. – CNG automotive fuel shall be labeled with its automotive fuel rating in accordance with 16 CFR Part 309.**

NCWM 2015 Annual Meeting: A joint session was held with the L&R and S&T Committees to hear this item along with Item 232-4 and S&T Item 337-1. (Documentation for the S&T Item 337-1 can be found within the S&T report.) The Committee acknowledged receiving letters in support of these items and that the majority of comments made during the Open Hearings were also in support of this proposal. It was noted that measurement principles, value comparisons, traceability (note: equivalents are not traceable) need to be analyzed. It is difficult to work with equivalent values that fluctuate in value. There is a task group under the FALS that is currently looking at the equivalent numbers. A corrected document was received for Appendix A., Background and Justification for NIST Handbook 130, Definition of “Diesel Gallon Equivalent (DGE)” of Compressed Natural Gas (CNG) and Liquefied Natural Gas (LNG) as a Vehicular Fuel.

A majority of the Committee believe that the changes submitted during Open Hearings are fully developed and will align with language proposed in S&T Item 337-1. The language changes support clarifying that two types of natural gas exist as a motor vehicle fuel [compressed and liquefied]. Additionally, the proposal makes it clear that the method of sale for compressed natural gas may be either GGE, DGE, or mass, and for liquefied natural gas the method of sale may be DGE or mass; however, all natural gas sold as a vehicle fuel shall be measured in mass. This Item along with Items 232-4 and S&T Item 337-1 received a split vote, therefore, it was returned to the Committee.

**Regional Association Comments:**

CWMA received numerous comments from both industry representatives and regulators. No new issues surfaced, and based on the number of comments heard, most of the comments pointed toward the need to keep the method of sale in mass, and that continued utilization of equivalencies is not in keeping with appropriate metrological practices. However, a supplemental marketing statement similar to the proposal developed by NIST would be useful to consumers. Mr. Ronald Hayes, who serves on the Natural Gas Steering Committee, indicated that the group met via teleconference in the week previous to the CWMA meeting and continues to work through this issue. Mr. Constantine Cotsoradis, Flint Hills Resources, presented an amendment to the Method of Sale section, which was forwarded to the Steering Committee for their consideration. Due to the contentious nature of this issue, further work is merited by the metrological community and industry. The Committee believes there is no evidence that suggests equivalency measures are appropriate for a method of sale. The Committee believes there is merit for consideration in the newly proposed verbiage because retail sales occur in other locations other than a retail dispenser. The Committee also recognizes the importance of consumer understanding and acceptance, and believes this issue needs to continue development through the Natural Gas Steering Committee.

CWMA 2015 Annual Meeting: Discussions were robust and reflected the same positions and information as prior meetings and dialogue. The Committee believes the item is fully developed. At the CWMA voting session, a vote of acclamation was too close to determine. The Chair opted for a show of hands, followed by a standing vote. The item passed with a vote of 18 For, 17 Opposed. The item has been fully developed and is ready for Voting status.

WWMA 2014 Annual Meeting: It was heard that the Natural Gas Steering Committee (NGSC) is reviewing: natural gas dispenser labeling requirements; refining the current proposal based upon feedback including data from the CRC regarding sampling to determine the average natural gas BTU content and data from the American Transportation Research Institute regarding the average BTU content of diesel fuel; and drafting an alternative proposal for the 2015 NCWM Interim Meeting.

WWMA recommended that NCWM consider all alternatives, including the NIST alternate proposal. However, if the NCWM determines that DGE/DLE is an appropriate method of sale for natural gas, the WWMA recommended that the sale of CNG at high-flow retail motor fuel dispensers be in units of DGE/DLE only, and at low-flow CNG retail motor fuel dispensers, allow GGE/GLE only. WWMA felt it would be confusing for drivers of light duty CNG vehicles to see prices expressed in both GGE and DGE. Also, WWMA suggested the NCWM consider a customer activated selectable display for indication at the dispenser (GGE/DGE/lb or GLE/DLE/kg). WWMA recommended striking the word “approximately” from Sections 3.11.2.2.2. and 3.12.2.2.2. because an approximate amount cannot be conclusively verified.

Several regulators offered comments, both in support and in opposition, similar to those received at previous meetings. Five regulators supported the NIST alternative. One regulator commented that other fuel marketers may seek a gallon-equivalent for their fuels (e.g., electricity).

WWMA 2014 Voting Session: One regulator noted the WWMA had previously recommended withdrawing all agenda items relating to DGE/DLE, and requested the L&R Committee poll the voting members to see how many are in support of the continued use of equivalent units. The voting results were 23 in opposition to the use of equivalent units, and 12 in support of using equivalent units “going forward.” WWMA recommended this remain an Informational item.

NEWMA 2014 Interim Meeting: NEWMA recommended that the NGSC consider that the method of sale be changed to mass and the NIST proposal to modify Section 3.3.7. Mass Flow Meters in NIST Handbook 44 (2014 Edition) be considered. (The draft NIST proposal is on the NEWMA Web Site as a supporting document <http://www.newma.us/meetings/interim/meeting-documents>.) NEWMA recommended that this Item 237-1 and Item 337-1 from the S&T Committee agenda be Informational items pending final language from the NGSC at the NCWM 2015 Interim Meeting.

NEWMA 2015 Annual Meeting: There were concerns that this change further confuses consumers. Consumers are adaptable to the marketplace. The Committee is anxious to learn more about work being done on verifiable equivalency conversion factors, which is being worked on by the Natural Gas Conversion WG. A motion was made to continue this as a Voting item along with Item 237-1 and S&T Committee Item 337-1. At the voting session, no second was received on the motion and all items were returned to the Committee.

SWMA 2014 Meeting: The Committee heard from Dr. Matthew Curran (Florida) that the NGSC was working on the item and FALS had deferred the work to the NGSC. The SWMA recommended that the item be an Informational item.

Additional letters, presentations, and data may have been part of the Committee’s consideration. To review the supporting documentation, please refer to the *Report of the 99<sup>th</sup> National Conference on Weights and Measures* (SP1193, 2014).

**237-2 I Sections 2.1.3. Minimum Antiknock Index (AKI), Section 2.1.4. Minimum Motor Octane Number, and Section 3.2.5. Prohibition of Terms – Table 1.**

**Source:**  
General Motors (2013)

**Purpose:**  
Remove obsolete Altitude De-rating of Octane practice, establish a National Octane Baseline, and harmonize Octane Labeling from state to state.

**Item Under Consideration:**  
Amend the NIST Handbook 130, Engine Fuels and Automotive Lubricants Regulation as follows:

**Section 2. Standard Fuel Specification**

**2.1.3. Minimum Antiknock Index (AKI). – The AKI of gasoline and gasoline-oxygenate blends shall not be less than 87.** The AKI shall not be less than the AKI posted on the product dispenser or as certified on the invoice, bill of lading, shipping paper, or other documentation;  
**(Amended 20XX)**

**2.1.4. Minimum Motor Octane Number. – The minimum motor octane number shall not be less than 82. ~~for gasoline with an AKI of 87 or greater;~~**  
**(Amended 20XX)**

### Section 3. Classification and Method of Sale of Petroleum Products

#### 3.2. Automotive Gasoline and Automotive Gasoline-Oxygenate Blends

**3.2.5. Prohibition of Terms.** – It is prohibited to use specific terms to describe a grade of gasoline or gasoline-oxygenate blend unless it meets the minimum antiknock index requirement shown in Table 1. Minimum Antiknock Index Requirements.

Table 1. Minimum Antiknock Index Requirements		
Term	Minimum Antiknock Index	
	ASTM D4814 Altitude Reduction Areas IV and V	All Other ASTM D4814 Areas
Premium, Super, Supreme, High Test	90	91
Midgrade, Plus	87	89
<del>Regular-Leaded</del>	86	88
Regular, Unleaded (alone)	85	87
<b>Economy</b>	–	86

(Table 1. Amended 1997 and 20XX)

#### Background/Discussion:

These recommended changes to NIST Handbook 130, Engine Fuels and Automotive Lubricants Regulations to the octane will harmonize with an effort underway in the ASTM International (ASTM) Gasoline and Oxygenates Subcommittee to include a minimum motor octane number (MON) performance limit in gasoline. The naming of the various octanes is a function for weights and measures.

Nominally, vehicles manufactured after 1984 include engine computer controls maintaining optimal performance while using gasoline octane of 87-AKI or higher. The practice of altitude de-rating of octane, resulting in octanes below 87-AKI, reduces a vehicle's efficiency and fuel economy. Increasingly, more vehicles are boosted (turbocharged/supercharged) eliminating altitude intake air effects. Additionally, consumers using gasoline with an octane AKI below 87 will void their vehicle owner's warranty. The Coordinating Research Council (CRC) Report No. 660, "*Fuel Anti-knock Quality – Engine Response to RON (Research Octane Number) versus MON*," May 2011 demonstrates the continued need for gasoline MON octane for the large bored, naturally aspirated U.S. engines. Setting an 82-MON minimum maintains the current MON level for today's 87-AKI Regular Unleaded gasoline. A common U.S. octane specification between ASTM, NCWM, and Vehicle Owners Manuals will give states clear direction on how best to enforce proper fuel pump octane labeling and quality levels on behalf of vehicle consumers.

Leaded gasoline is not available at retail and, therefore, labeling guidance is not needed.

NCWM 2013 Interim Meeting: The FALS could not reach agreement on this item during their Sunday work session. The Committee received and reviewed several letters in support of this proposal. During Open Hearings, Mr. Studzinski (General Motors) provided a presentation. The Committee also received comments in opposition to the proposal citing the lack of consumer complaints with sub octane, and it was requested that the Committee wait until the CRC study provides data that can be used by ASTM and NCWM to determine whether or not a change is necessary. The Committee recommends this be an Informational item.

NCWM 2013 Annual Meeting: Mr. Hayes, FALS Chair, provided a presentation and stated that the CRC study has been expanded and finalized data is expected by year end. It was also noted the ASTM ballot failed. The Committee

concur to await a recommendation from FALS once they have considered all the data. At the 2014 NCWM Interim Meeting, Mr. Studzinski provided an update that the CRC study is almost finalized and then a ballot will be prepared for ASTM. Mr. Studzinski will have additional information for the 2015 NCWM Interim Meeting.

NCWM 2014 Annual Meeting: Dr. Matthew Curran, FALS Chair, remarked that the FALS is recommending this remain an Informational item until the CRC study results are complete. Mr. Studzinski provided a briefing that a report should be issued in the fall of 2014.

NCWM 2015 Interim Meetings: The FALS Chair notified the Committee that the CRC study is still being finalized. The L&R Committee is designating this as an Informational item.

NCWM 2015 Annual Meeting: The FALS Chair provided an update stating this item was on the ASTM ballot and did not pass at the June 2015 ASTM Meeting. ASTM is evaluating the negative ballots. FALS would like to await further action within ASTM before changes are considered by the Conference.

**Regional Association Comments:**

CWMA 2014 Annual Meeting: It was reported that that Mr. Studzinski (General Motors) provided an update at the 2014 NCWM Annual Meeting and the information is posted on the NCWM website. Mr. Studzinski indicated that this item is waiting on the CRC study final report which is anticipated before the 2015 NCWM Interim Meeting. The CRC study results will provide additional information to determine the future path of this item.

CWMA 2015 Annual Meeting: An industry representative from Marathon indicated there is an ASTM ballot that closes June 12 that requires a minimum 87.0 octane and 82.0 Minimum Octane Number (MON). This issue will be further discussed at the June ASTM meeting. An industry representative from BP commented that negative ballots would be adjudicated in June, and the decision will be made whether or not to move forward to the main D02 Committee at the December meeting. The Committee is recommending this remain Informational until additional information is received.

WWMA 2014 Annual Meeting: Opposition was heard from two regulators. There was support from one regulator, who said that in his state, competing stations in the same city sell regular gas at two different octane levels. Two state directors recommended removing the word “leaded” from Table 1. WWMA recommended the NCWM consider the data in the CRC study before determining the appropriate status for this item.

NEWMA 2014 Interim Meeting: The L&R Chairman commented that the CRC study related to this item has not yet been released, but should be by the 2015 NCWM Interim meeting. An industry representative who is a member of the FALS commented that the study will be published before the Interim Meeting, and FALS will be in a position by January to give L&R a recommendation as to how this item should move forward. NEWMA recommended the item remain an Informational item. At the 2015 NEWMA Annual Meeting, they were informed the CRC study has yet to be released and agree this should remain Informational.

SWMA 2014 Annual Meeting: The Committee heard that CRC had finished the study and was evaluating the results. A report should be issued by the end of the year. The Committee was also made aware that FALS was working on the issue. SWMA recommended that the item be an Informational item.

Additional letters, presentations, and data may have been part of the Committee’s consideration. To review the supporting documentation, please refer to the *Report of the 99<sup>th</sup> National Conference on Weights and Measures* (SP1193, 2014).

**237-3 V Section 4.3. Dispenser Filters**

(This item returned to Committee.)

**Source:**

Missouri Department of Agriculture (2012)

**Purpose:**

Recognize the need for 10-micron or smaller nominal pore-sized filters for today's diesel engines.

**Item Under Consideration:**

Amend the NIST Handbook 130, Engine Fuels and Automotive Lubricants Regulation as follows:

**4.3. Dispenser Filters.****4.3.1. Engine Fuel Dispensers.**

- (a) All gasoline, gasoline-alcohol blends, gasoline-ether blends, ethanol flex fuel, and M85 methanol dispensers shall have a 10 micron or smaller nominal pore-sized filter.
- (b) All biodiesel, biodiesel blends, diesel, and kerosene dispensers shall have a ~~30~~ **10** micron or smaller nominal pore-sized filter except for dispensers with flow rates greater than 15 gallons per minute which shall have a 30 micron or smaller nominal pore size filter.

(Added 2008) (Amended 2014 and 20XX)

**Background/Discussion:**

Abnormal dispenser filter plugging at retail will alert the retailer of potential storage tank problems. Requiring 10 micron filters for all products will reduce the inventory of types of filters and the potential of installing the wrong filter for all products at the same site.

NCWM 2012 Interim Meeting: Mr. Ronald Hayes, FALS Chair, informed the Committee that FALS recommended that this item be Informational because of industry concerns that 10 micron filters would be too restrictive of flow in high-flow systems. One industry representative expressed opposition for the use of 10 micron filters and recommends this item to be Withdrawn. A representative of an automobile manufacturer claimed diesel passenger vehicles do not have the sophisticated filtration systems commonly found on commercial heavy duty vehicles and 10 micron filters on dispensers are needed for protection from particulate contamination. As proposed, this item could cause clogging of diesel dispenser filters in colder climates. The Committee believes this item has merit but lacks a consensus and also believes that FALS needs to address these concerns. The 2012 L&R Committee designated this item as an Informational item and assigned it to FALS for further development.

NCWM 2012 Interim Meeting: It was apparent to the Committee that there are many unresolved issues related to passenger vehicles. The Committee encourages the FALS to continue developing this item.

NCWM 2012 Annual Meeting: Several stakeholders spoke in opposition on f this item. Mr. Ronald Hayes, FALS Chair remarked that the FALS worked on this item in 2007 and believes FALS needs to continue to work on this item. The NCWM L&R Committee agreed that this item is not ready and supports the continued development by FALS.

NCWM 2013 Interim Meeting: Mr. Hayes, FALS Chairperson, remarked that a similar item was brought before the Committee in 2007. FALS did not have enough time in their work session to work on this item. There are several stakeholders and states that are having issues with the terminology and would like it removed from the agenda. Mr. Hayes (Missouri) remarked that they supported this item because contamination is an issue with cars that do not have filtering systems. The Committee reviewed comments from the Regional Associations; however, FALS did not have sufficient time to review and make recommendations to the Committee. The Committee would like for FALS to continue to work on this item and is proposing this be an Informational item.

NCWM 2013 Annual Meeting: Mr. Hayes, FALS Chair, requested that the Committee allow them to continue to work on a recommendation for this item. There was opposition on moving this item forward. In less than two years since this proposal came forward there has been no data developed. The Committee reviewed Regional Association reports, Open Hearing comments, and letters received, and then changed the status of this item to Developing.

NCWM 2014 Interim Meeting: Mr. Hayes (Missouri) who submitted the proposal offered modified language and supporting data to support the flow rate on 10-micron diesel filters. There was considerable discussion in regards to the fill time reduction, burdensome cost for station owners, and equipment and filter maintenance. It was noted that there is work being done within ASTM but at this time that information cannot be shared. The Committee reviewed the Item Under Consideration within NCWM Interim Publication 15 (2014). The Committee moved forward the modified language provided by Mr. Hayes for consideration as a Voting item.

NCWM 2014 Annual Meeting: The Committee reviewed several letters and additional data submitted by the Petroleum Marketers Association of American (PMAA). The FALS recommended this Item move forward for a Vote. During the open hearing there were mixed concerns in regards to this this Item. Numerous concerns were expressed regarding the data from PMAA. Several comments were heard that ASTM should be allowed to develop a standard.

NCWM 2015 Interim Meeting: The FALS Chair notified the Committee that this proposal was discussed in their work session and the FALS group is divided on a recommendation. Mr. Russ Lewis (Marathon Petroleum Co.) submitted the CRC Report "Diesel Fuel Storage and Handling guide. In addition, Prentiss Searles (API) provided the Committee with a listing of the various studies and the findings that support moving this Item forward. The Committee reviewed additional letters and Regional Association recommendations. During open hearing testimony, there was discussion as to whether this is a weights and measures issue or a housekeeping issue for the stations. There was lengthy discussion as to the type of particulates and contaminates a 10-micron filter could remove. Cost effectiveness was a concern as to who would bear the burden of the cost. With the extensive discussion on this subject matter and new information received, the Committee is designating this item as a Voting item.

NCWM 2015 Annual Meeting, Mr. Lewis (on behalf of API) provided a presentation on dispenser filters. Mr. Curran (FALS Chair) informed the Committee that FALS is divided on this issue but would like it to proceed with a Vote. There were no new comments other than those that have already been provided in this report. The outcome of the voting session was a split vote; therefore, it was returned to the Committee.

#### **Regional Association Comments:**

CWMA's L&R Committee heard no opposing comments and believes the proposal protects consumer vehicles and alerts retailers of potential product quality problems. Comments from previous meetings included a remark from an official indicating a smaller porosity filter may be acceptable, but for now this is a reasonable start. General Motors (GM) supported this item for passenger vehicles, as these vehicles now have 4-micron filters. Several industry representatives did not support this item during a past meeting because they believe this is a dispenser protection issue rather than a consumer protection issue. A state regulator remarked it is a fuel quality issue, which impacts consumers' vehicles and fuel systems. Officials clarified that the proposal should only apply to passenger type vehicles, and it would specifically exempt high-flow rate meters such as truck stop meters. CWMA supported the following proposal and recommended it as a Voting item.

### **1.3. Dispenser Filters.**

#### **4.3.1. Engine Fuel Dispensers.**

- (a) All gasoline, gasoline-alcohol blends, gasoline-ether blends, E85 fuel ethanol and M85 methanol dispensers shall have a 10 micron or smaller nominal pore-sized filter.
- (b) All biodiesel, biodiesel blends, diesel, and kerosene dispensers shall have a ~~30~~ **10** micron or smaller nominal pore-sized filter **except for dispensers with flow rates greater than 15 gallons per minute which shall have a 30 micron or smaller nominal pore size filter.**

CWMA 2014 Annual Meeting: A regulator commented this item has been vetted through the regions several times. There is additional data on the NCWM website that was shared with FALS. It was stressed that this item is for retail motor fuel dispensers for passenger vehicles not high-flow meters. The regulator also mentioned the work done by his staff during cold weather to test whether or not flow rates through 10-micron filters were more diminished than fuel flowing through 30-micron filters during sub-zero weather. The regulator stated FALS supports this item. A second regulator commented that he was seeking clarification on whether determination of the flow rate would be made with a marked flow rate or flow rate at the dispenser. Other regulators stated the intent was to have 10 micron filters on passenger vehicle dispensers and light trucks only. This proposal best accomplishes that end. An industry representative asked about the cost between the 10-micron filters and 30-micron filters. A regulator responded costs were the same. The CWMA L&R Committee believes the item has been fully developed and is ready for Voting.

CWMA 2015 Annual Meeting: Mr. Lewis (Marathon Oi) gave a presentation related to this project. He spoke in favor of the proposal. A representative from BP commented that when they owned retail stations, they required 10-micron filters on diesel dispensers. Currently, when they work with jobbers, they still recommend it. He spoke in favor of the proposal. A regulator from Minnesota commented that if a filter is the last line of defense, it is a positive step for consumers, and spoke in favor of the proposal. A regulator from Missouri commented that any state with a fuel quality program should have a dispenser filter requirement of 10 microns. It is even more critical in diesel engines today for the fuel to be as clean as possible due to the high pressure technology in the engines. The Committee moved this forward as a Voting item.

WWMA 2013 Annual Meeting: It was heard from one regulatory official recommending Withdrawal of the item because it is unnecessary. There is concern with the potential negative impact on the speed of fuel delivery. The submitting regulatory official supports the item with the language for Section 4.3.1.(b) as presented above in the CWMA Interim Report. WWMA recommends this item as a Voting item.

WWMA 2014 Annual Meeting: Opposition was heard on this item from two regulators. Mr. Ronald Hayes (Missouri), spoke in favor of the item, saying that it would help protect high-pressure fuel rails in today's diesel engines and that the auto manufacturers and Engine Manufacturers Association (EMA) want this amendment. Mr. Hayes stated additional data (subsequent to the Petroleum Marketers Association of America study) will be posted on the NCWM website under NCWM Publication 15 documents prior to the 2015 Interim Meeting. WWMA recommended this remain an Informational Item and that NCWM wait until they receive new additional data and can determine the appropriate status.

NEWMA 2014 Interim Meeting: A regulator commented that the item should be Withdrawn from the agenda because weights and measures should not legislate a filter size. Another regulator stated it was the responsibility of ASTM to provide a standard that yields fuel fit for purpose. An industry representative from petroleum marketers opposes this item. NEWMA recommended that this item be Withdrawn.

NEWMA 2015 Annual Meeting: A presentation was provided by Mr. Russ Lewis (Marathon Petroleum) on behalf of the American Petroleum Institute (API). Among other topics, Mr. Lewis indicated the EPA is looking more closely at filter issues in general, and their report is due to be released during summer 2015. After the presentation, a retired official asked what was coming from the terminal that could cause filter plugging. Mr. Lewis indicated that the most effective way to address particulate matter in fuel is to have a robust maintenance system throughout the entire fuel distribution system. A state official asked about Europe's experience with diesel fuel. Part of the more stringent diesel specification in Europe requires a fuel filter with a 5-micron pore size. A regulator asked if there was more frequent filter changing. Mr. Lewis indicated if the only thing you do when a filter is clogged is replace the filter, it will be more frequent. However, if a frequently clogged filter leads to better tank maintenance, once the tanks are cleaned, filter replacements will be less frequent. A PMD Corporation official indicated that they are seeing a lot of problems with filters being damaged, and they would support better fuel housekeeping, and supports 10-micron filters. A state regulator commented that the information in Mr. Lewis's presentation changed his mind to support moving a 10-micron filter. NEWMA feels that this item is fully developed and recommended that it be a Voting item.

SWMA 2011 Annual Meeting: It was reported that an industry representative stated that standard retailer dispensers use a 10-micron filter, and high capacity dispensers use 30-micron filters (i.e., diesel dispensed at truck stops). The company's engineers have determined that reducing a 30-micron filter to a 10-micron filter will drastically reduce flow rate to trucks. Another industry representative agreed and re-iterated that truck stops would see a tremendous



reduction in flow. The Committee believed this proposal was not practical and would have a negative impact and undue burden on the trucking industry. SWMA did not forward the item to NCWM.

SWMA 2012 Annual Meeting: An industry representative commented that the current technology to put a 10-micron filter on diesel at a truck stop will prohibit fuel from being dispensed in a timely manner and, therefore, opposes this. The Committee recommends the use of 10-micron filters be limited to passenger vehicle meters and specifically exempt high-flow rate meters. SWMA recommended the item be a Voting item but with the changes as described by the Committee.

SWMA 2013 Annual Meeting: The SWMA supported moving this item forward as a Voting item on the NCWM agenda modifying the requirements to read; 10-micron filters on devices delivering 15 gpm or less and 30-micron filters for greater than 15 gpm.

SWMA 2014 Meeting Committee was given a copy of the CRC Report No. 667, Diesel Fuel and Handling Guide. The Committee heard that a study had been completed on low temperature flow rates and that information was on the FALS section of the NCWM website. The CRC report is available at [www.crcao.org](http://www.crcao.org). The SWMA recommended that the item be Informational.

Additional letters, presentations, and data may have been part of the Committee's consideration. To review the supporting documentation, please refer to the *Report of the 99<sup>th</sup> National Conference on Weights and Measures* (SP1193, 2014).

## 260 HANDBOOK 133

### 260-1 V Section 2.7. Chitterling Test Procedure.

(This item was Adopted.)

**Source:**

NIST Office of Weights and Measures (2015)

**Purpose:**

Provide inspectors and packers with uniform test methods and include a specific purge requirement in NIST Handbook 133.

**Item Under Consideration:**

Amend NIST Handbook 133 as follows:

**2.7. Determining the Net Weight and Percent of Purge in Packages of Fresh and Frozen Chitterlings.**

**2.7.1. Test Equipment.**

- **Scale or balance and mass standards (the standards are used to verify the accuracy and repeatability of the weighing device).**
- **Partial immersion thermometer or equivalent with 1 °C (2 °F) graduations and a range of - 35 °C to + 50 °C (- 30 °F to + 120 °F) accurate to ± 1 °C (± 2 °F).**
- **Sink (e.g., water bath, ice chest) or other receptacle of suitable size to hold the packages for thawing and water source and hose with fresh water that can be maintained at a temperature between 23 °C to 29 °C (75 °F to 85 °F) (for thawing plastic bags or buckets of chitterlings).**

**An alternative thawing procedure for packages requires access to a refrigerator that must be available for storing sample packages for several days to thaw.**

- Stainless Steel Sieve(s) and Drain Pan(s) – No. 8 mesh, 203 mm (8 in) or 304 mm (12 in). Use is based on the labeled net weight of the package under inspection.
- Chitterlings Worksheet for Category A and Category B (See Appendix C)
- Stopwatch (to measure drain periods).
- Knife or box cutter (to open packages).
- Waterproof marking pen (for numbering the packages).
- Disposable (non-latex) gloves.
- Paper towels (drying sieve drain pan, packages and work area).
- Large plastic bags (to hold product emptied from packages).
- Plastic rod (to insert into buckets of chitterlings to determine if the product is thawed and to ensure there are no chunks of ice remaining).

#### 2.7.2. Test Procedure for Net Weight and Purge Determination for Fresh and Frozen,

This procedure is used to determine (1) the net weight and (2) the purge in packages of fresh and frozen chitterlings. The purge determination procedure requires the destructive testing of all of the sample packages.

1. Follow Sections 2.3.1. “Define the Inspection Lot,” 2.3.2. “Select Sampling Plans.” Use Appendix A, Table 2-1. “Sampling Plans For Category A,” if the testing is outside of a USDA inspected packing facility or use Table 2-2. “Sampling Plans for Category B,” if the testing is inside a USDA inspected packing facility, 2.3.3. “Record Inspection Data”, and 2.3.4. “Random Sample Selection”.
2. Select the random sample of packages.
3. Dry the sample packages and number each (e.g., 1-12) using a waterproof marker.
4. Record the Product Brand, Inspector Name, Labeled Net Weight (top of Column A), Packer Identity, Lot Code, Number Unreasonable E, MAV from Table 2-9, and the Unit of Measure of the scale used for weight determinations on the Chitterling Worksheet. The appropriate information can be transferred to an official inspection report at the conclusion of the inspection. The worksheet should be added to the official record of the inspection.

##### 2.7.2.1. Net Weight and Purge Determinations

Follow these procedures to determine the net weight and amount of purge from chitterlings.

##### 2.7.2.1.1. Test Procedure for Determining the Net Weight and Purge from Fresh and Frozen Chitterlings

1. Determine the Gross Weight of each sample package (record in Column B),
2. Determine the tare weight of the sieve drain pan (record in Drain Pan Tare above Column F).

**Frozen Chitterlings**

3. **Fully immerse the unopened package of frozen chitterlings in a water bath maintained at a temperature between 23 °C to 29 °C (75 °F to 85 °F).**

**Note: An alternative approach to thawing large frozen packages (e.g., 5 kg [10 lb] plastic pails) is to randomly select [mark them to be held for inspection] the sample packages and place them in a refrigerator for partial thawing over several days and then carrying out the final thawing using the water bath technique.**

**Note: If the products are to be placed in refrigerated storage for several days for partial thawing, segregate them from other product inventory and mark each container with an identifier to allow the inspector to ensure that they were the samples selected for testing (mark both lid and container on buckets) when the inspection is resumed after the thawing process. Also, mark the packages with a conspicuous notice that they are being held for inspection.**

4. **Maintain a continuous flow of water into the bath to keep the temperature within the specified range until the chitterlings are thawed. The chitterlings are thawed when it is determined by touch that they are not rigid and no ice crystals are observed or felt within or on their outside surface.**

**Note: for buckets insert a plastic rod into the chitterlings to determine if the product is thawed and to ensure there are no chunks of ice remaining.**

**Fresh and Frozen Chitterlings**

5. **Draining the Chitterlings: Depending on the availability of a sink and work space and the inspector’s preference, use the procedures in either Method A. or Method B. to drain the chitterlings. Refer to Table 1 for the appropriate size sieve to use based on the labeled net weight on the package.**

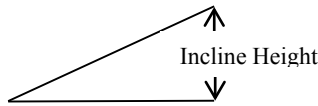
<b><u>Table 1.</u></b>			
<b><u>Labeled Net Weight</u></b>	<b><u>Sieve Diameter</u></b>	<b><u>30 Degree Tilt from Horizontal</u></b>	<b><u>Incline Height</u></b>
<b><u>If more than 453 g (1 lb) use:</u></b>	<b><u>300 mm (12 in)</u></b>		<b><u>175 mm (6.9 in)</u></b>
<b><u>If less than 453 g (1 lb) use:</u></b>	<b><u>203 mm (8 in)</u></b>		<b><u>116.8 mm (4.6 in)</u></b>
<ul style="list-style-type: none"> <li>• <b><u>This procedure requires that the sieve and drain pan be cleaned and dried after each use. It is a good measurement practice to obtain the dry weights of both the sieve and pan and recheck those weights periodically during the test to make sure the cleaning and drying procedures are efficient.</u></b></li> <li>• <b><u>If the amount of chitterlings in the package exceeds the capacity of the sieve, divide the solids evenly among two or more sieves of the same dimensions or make multiple determinations using a single sieve. Exercise care when transferring the chitterlings into the sieves to avoid spilling liquid which can void the test.</u></b></li> </ul>			

**Method A. Place a sieve over a sink or waste collection container. Pour the chitterlings into the sieve and distribute them over the surface of the sieve with a minimum of handling. Hold the sieve firmly and incline it 30 degrees (see Figure 1 for an example of a tilt block for use with a sink drain set at 30 degrees) to facilitate drainage, then start the stop watch and drain for**

exactly two-minutes. At the end of the drain time immediately transfer the chitterlings to a Drain Pan for weighing. Determine the Purged Net Weight of the chitterlings using the following formula and Record in Column F of the worksheet

*Drained Chitterlings and Drain Pan – Drain Pan Tare = Purged Net Weight*

Method B. Place a sieve on its Drain Pan. Pour the chitterlings into the sieve and distribute them over the surface of the sieve with a minimum of handling. Hold the sieve firmly and incline it 30 degrees to facilitate drainage, then start the stop watch and drain for exactly two-minutes. At the end of the drain time immediately transfer the Drain Pan with the Purged Liquid to the scale for weighing. Dry the empty package to determine its tare weight and enter it in Column C. Determine the Purged Net Weight of the chitterlings using the following formula and record in Column F of the worksheet.

*(Gross Weight of Package – Package Tare Weight) – (Weight of Purged Liquid & Drain Pan – Drain Pan Tare) = Purged Net Weight*

*(Column B – Column C) – (Weight of Purged Liquid & Drain Pan – Drain Pan Tare) = Purged Net Weight*

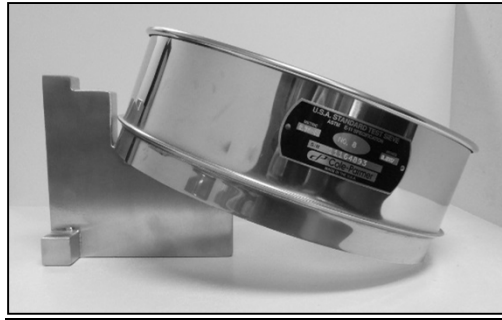

Figure 1. Tilt Block set at 30 degrees.

6. Calculate Purge using the formula shown below (use the labeled net weight in Column A and NOT the gross weight of the package in Column B) and record the result in Column G of the worksheet.

$$\text{Purge in \%} = (\text{Labeled Weight} - \text{Purged Net Weight}) \div \text{Labeled Weight} \times 100$$

$$\text{Purge in \%} = \text{Column A} - \text{Column F} \div \text{Column A} \times 100$$

Example: The labeled net weight is 5 lb and the Purged Net Weight is 4.19 lb

$$\text{5 lb} - \text{4.19 lb} = \text{0.81 lb} \div \text{5 lb} = \text{0.162} \times \text{100 \%} = \text{16.2 \% purge}$$

7. Dry the empty package and determine its tare weight (Record in Column C of the worksheet.)
8. Subtract the individual Package Tare Weight from the individual Package Gross Weight to obtain the Actual Package Net Weight (Record in Column D of the worksheet). Do not use an Average Tare Weight. Use the formula:

$$\text{Actual Package Net Weight} = \text{Gross Weight} - \text{Tare Weight}$$

$$\text{Actual Package Net Weight} = \text{Column B} - \text{Column C}$$

9. Subtract the Actual Package Net Weight from the Labeled Net Weight (record in Column E of worksheet). Use the formula:

$$\text{Package Error} = \text{Labeled Net Weight} - \text{Actual Package Net Weight}$$

$$\text{Package Error} = \text{Column A} - \text{Column D}$$

10. Repeat for all packages in the sample.

Note: The determination of compliance with the net weight and purge requirements are carried out concurrently. The calculation of the average net weight and average purge is completed after all of the packages are opened and all purge amounts are obtained. The sample must pass both the net weight and purge tests to comply with this section.

**2.7.3. Evaluations of Results – Compliance Determinations**

**1. Net Weight**

- a. Individual Package Requirement: If there are negative package errors, determine if any of the values exceed the Maximum Allowable Variation (MAV) for the packaged quantity in Appendix A, Table 2-9. “U.S. Department of Agriculture, Meat and Poultry Groups and Lower Limits for Individual Packages” (i.e., if the labeled net weight is more than 3 lb up to 10 lb then the MAV = 42.5 g (0.094 lb) 1.5 oz).

- If a package error exceeds the MAV, mark it as “Failed” in the MAV Fail column.
- Count the number of packages that exceed the MAV. If the number of packages that exceed the MAV is greater than the number allowed as specified in Appendix A, Tables 2-1. “Category A” or Table 2-2. “Category B”, the sample fails. Mark the sample as “Failed” in the box “Net Weight Compliance.”
- If the sample passes the Individual Package Requirement, apply the Average Error Requirement.

- b. Average Error Requirement: Sum the package errors in Column E and enter the value in Box E1-Total Error. Divide the value in Box E1 by the Sample Size (n) to obtain an Average Error and enter the value in Box E2. If the Average Error (E2) is a positive number, the sample passes. Go to the Net Weight Compliance Section and mark the sample as “Passed.”

- If the Average Error (E2) is a negative number, calculate the sample standard deviation of the package errors (Column E) and enter it in the block “Net Weight Compliance section.
- Use the Sample Correction Factor (SCF) to calculate the Sample Error Limit (SEL).

$$\text{Sample Error Limit (SEL)} = \text{Sample Standard Deviation} \times \text{Sample Correction Factor}$$

- Disregarding the signs,
  - if Average Error (E2) is larger than the SEL, the sample fails. Mark it “Failed” in the Net Weight Compliance Section of the worksheet.

or

- if the Average Error is less than the SEL, the sample passes. Go to the Net Weight Compliance Section and mark the sample as “Passed.”

## 2. Purge

Follow these procedures to determine the amount of purge from the chitterlings. Apply the Average Requirement in accordance to Section 2.3.7.2. to the purge to determine if the sample passes or fails the requirement. The Average Adjusted Purge (AAP) for the sample shall not exceed 20 % of the labeled weight. The Maximum Allowable Variations (MAV) (Lower Limits for Individual Packages) in Appendix A, Table 2-are not applied in the purge test.

- Sum the purge values in Column G and enter the value in G1-Total Purge. Divide the value in G1 by the Sample Size (n) to obtain an Average Purge and enter the value in G2. If the Average Purge (G2) is less than or equal to 20 %, the sample passes. Go to the Purge Compliance Section and mark the sample as “Passed.”
- If Average Purge is greater than 20 %, calculate the Sample Standard Deviation of the values in Column G and enter it in the block provided in the Purge Compliance Section.
- Use the Sample Correction Factor (SCF) to calculate the Purge Sample Error Limit (PSEL) in percent.
- Subtract the PSEL from the Average Purge (G2) to obtain an Adjusted Average Purge (AAP) and enter that value in G3.
- Pass or Fail
  - If AAP (G3) is greater than 20 %, the sample fails. Enter the Purge Value (G3) in the Purge Value Compliance section and mark the sample as “Failed.”
  - or
  - If AAP (G3) is 20 % or less, the sample passes. Enter the Purge Value (G3) in the Purge Compliance section and mark the “Passed.”

### **Background/Discussion:**

There are no test procedures or purge requirements for chitterlings and beef tripe in NIST Handbook 133. Currently the states must adapt the drained weight test procedures and then rely on purge allowances published on USDA websites to test these products. Adoption of the test procedures and inspection forms will ensure that inspectors and packers have recognized test procedures to use that are uniform and will allow for the collection of test data that can then be used in affirming or modifying the current 20 % limit on purge that the USDA websites cite. These commodities are typically tested on a complaint only basis. Over the past several years, several states and packers have requested guidance on the test procedure and have questioned the reasonableness of the current allowances. NIST, OWM has worked with several packers and states to develop and test the attached procedures with the goal of having the proposal submitted for consideration by the NCWM for possible adoption.

It will provide states with ready access to a test procedure for these unique products should they receive a consumer complaint. Currently when officials receive complaints on these products the inspector must carry out extensive research to find the necessary information for conducting tests of these products, and they may not find out about the USDA information until after they complete the inspection. In 2013 this difficulty may have led one state to test these products without making any allowance for the purge as required by the USDA.

Interim 2015 Meeting: A comment was made by a county in California as to whether this item is ready to be adopted as a test procedure due to the issue on the potential of excessive purge. The background information has different purge limits. If adopted, it should be done on an interim approach so that data can be used to validate the information.

The Committee believes this item is fully developed with all the information received. If the manufacturers are concerned, the L&R Committee would like to receive feedback. The 2015 L&R Committee is moving this forward as a Voting item.

NCWM 2015 Annual Meeting: A letter was received from the North American Meat Institute (NAMI) requesting an opportunity to conduct additional research and testing to determine if 20 % purge is reasonable for beef tripe. Until this is done NAMI requested that the term “beef tripe” be stricken from the proposal. The Committee removed the term “beef tripe” and footnote 1 and 9 from the test procedure.

Refer to Appendix B for the Executive Summary, additional background, and initial proposal for Section 2.7. Chitterling Test Procedure and sample test reports.

**Regional Association Comments:**

CWMA received comment from a Missouri regulator who asked if this issue was similar to seafood. An Illinois regulator indicated that the “purge” from the items would be different due to the cell structure of the differing proteins. The Committee concurs with NIST, OWM that a WG should continue to review and further evaluate the test procedure and existing purge limit. CWMA forwarded the item to NCWM, recommending it as a Developing Item.

CWMA 2015 Annual Meeting: An industry representative from Smithfield Foods commented that the test procedure is a positive measure, but there is concern with the proposed limits. A NIST Technical Advisor concurred that further study and validation needs to be done; however, USDA’s guidance is 20 % purge. NIST suggests that we consider moving forward with the testing procedure, collect data, and reevaluate the tolerance level once there is additional data collected. The industry representative commented that the proposal states that 20 % is a pass-fail parameter, and that poses concern to the industry. The NIST representative commented again that the only recommendation they have is that of USDA, and the proposal should either go forward and be amended later if data suggests it, or the Conference could wait until more data is collected, which could take years.

WWMA heard from one regulator who stated that this item is not ready for inclusion into NIST Handbook 133 because of the USDA FSIS response to the question about when to measure purge. The FSIS stated that “historically, FSIS has not objected to chitterlings having a 20 % purge due to the washing and preparation with water. Net weight should be verified after packaging and prior to freezing.”

WWMA suggested that NIST establish a voluntary WG to validate the draft testing procedures and verify the 20 % purge allowance. WWMA suggested that data be collected on water absorption prior to freezing *and* water purge after thawing frozen product. The Committee encouraged regulators with processing facilities in their jurisdictions to contact NIST to volunteer for this study; study results should not be based on data from frozen product only. WWMA recommended this item be a Developing Item.

NEWMA 2014 Interim Meeting: The L&R Chair commented that the testing of this type of product is problematic as there is no established test procedure to incorporate the unique content of this product after it has thawed. A state regulator suggested it be considered a Developing item. Another regulator suggested that NEWMA follow the lead of the Southern Region and recommend the item move forward with Voting status since there were NIST representatives at the Southern meeting to more fully explain the proposal. NEWMA forwarded the item to NCWM and recommended it as a Developing item to allow NIST to fully refine the testing procedures. At the 2015 NEWMA Annual Meeting, the Committee feels this item is fully developed and recommended that it be a Voting item.

SWMA 2014 Meeting: The Committee heard comments from NIST that the changes were needed as a result of testing issues in some states. The Committee was also provided with a copy of an executive summary report by NIST. SWMA forwarded the item to NCWM and recommended it as a Voting item.

Additional letters, presentations, and data may have been part of the Committee’s consideration. To review the supporting documentation, please refer to the *Report of the 99<sup>th</sup> National Conference on Weights and Measures* (SP1193, 2014).

**260-2 V Section 3.9. Dimensional Test Procedure for Verifying the Compressed Quantity Declaration on Packages of Peat Moss.**

(This item was Adopted.)

**Source:**

NIST, Office of Weights and Measures (2015)

**Purpose:**

Provide improved dimensional test procedures for the verification of the compressed volume of peat moss and animal bedding.

**Item Under Consideration:**

Amend NIST Handbook 133 by replacing section 3.9. Peat Moss in its entirety with the following:

**3.9. Peat Moss**

**3.9.1. Dimensional Test Procedure for Verifying the Compressed Quantity**

**3.9.1.1. ~~Test Equipment~~**

- ~~Tape measure~~

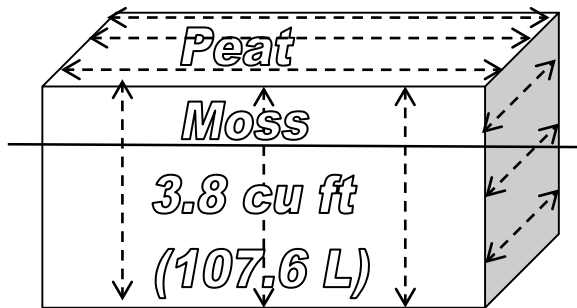

**Figure 3-1. Peat Moss**

**3.9.1.2. ~~Test Procedure~~**

- ~~1. Follow Section 2.3.1. "Define the Inspection Lot." Use a "Category A" sampling plan in the inspection; select a random sample.~~
- ~~2. For each dimension (length, width, and height) take three equidistant measurements.~~
- ~~3. —~~
- ~~4. Calculate the average of each dimension.~~
- ~~5. Multiply the averages to obtain the compressed cubic volume as follows:~~

$$\text{average height} \times \text{average width} \times \text{average length} = \text{cubic measurement}$$

- ~~6. Subtract the labeled volume from the measured volume to determine package error. (Amended 2010)~~



**3.9.1.1. Test Equipment**

- **Calculator or Spreadsheet Software (programmed to make volume calculations)**
- **Volumetric Package Worksheet (Appendix C at end of this report)**
- **Non-permanent marking pen.**
- **Knife or Razor Cutter (for use in opening packages and unwrapping shrink-wrapped pallets in warehouses)**
- **Cellophane or Duct Tape (for use in securing packaging tails)**
- **Dimensional Measuring frame (drawings are located at [www.nist.gov/owm](http://www.nist.gov/owm))**



**Figure 3-1. Picture of a Dimensional Measuring Frame.**

- **Rigid Rulers – Starrett<sup>1</sup> or equal with 1.0 mm graduations. The edges of a ruler used with a measuring frame must be straight and the edges must be the zero point (see Exhibit 2).**
- **300 mm (12 in)**
- **500 mm (19.5 in)**
- **1 m (39 inch)**
- **Carpenter Squares**
- **300 mm (12 in)**
- **600 mm (24 in)**

---

<sup>1</sup> Notice: The mention of trade or brand names does not imply endorsement or recommendation by the U.S. Department of Commerce over similar products available from other manufacturers.

**3.9.1.2. Test Procedure****Test Notes:**

**Rounding:** When a package measurement falls between graduations on a ruler, round the value up. This practice eliminates the issue of rounding from the volume determination and provides the packager the benefit of the doubt. If a ruler with a graduation of 1.0 mm is used, the rounding error will be limited to 0.5 mm or less. It is good practice to circle a measurement that has been rounded up or make a statement to such effect so that it becomes a part of the record.

**Dimension Identification:** The following package nomenclature is used to identify the dimensions measured in this test procedure.

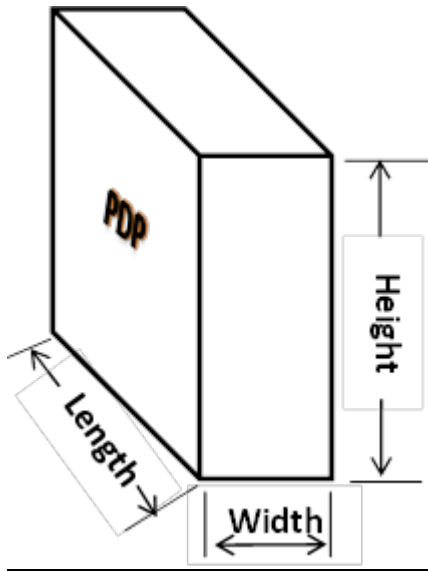

**Figure 3-2. Dimension Identification.**

**Note:** Packages of compressed peat moss do not have declaration of expanded volume.

**Safety**

**This procedure does not address all of the safety issues that users need to be aware of in order to carry out the following tasks. Users are sometimes required to conduct tests in warehouse spaces or retail stores where fork-trucks are in motion – care must be taken to warn others to avoid or exercise care around the test site. The procedure requires users to lift heavy objects including large bulky packages and test measures and includes the use of sharp instruments to obtain packages from shrink-wrapped pallets. Users may be required to climb ladders or work platforms to obtain sample packages. When opening and emptying packages, dust, or other particles may be present or escape from the packages, which may cause eye injuries and respiratory or other health problems. Users must utilize appropriate safety equipment and exercise good safety practices. If safe working conditions cannot be ensured, suspend testing until the situation is corrected.**

- 1. Follow the Section 2.3.1. “Define the Inspection Lot.” Use a “Category A” Sampling Plan for the inspection. Collect the sample packages from the Inspection Lot using random sampling.**

**If the packages are not randomly selected, the sample will not be representative of the lot and the test results will not be valid for use in enforcement action. Place the sample packages in a location where there is adequate lighting and ample space for the packages and test equipment.**

- 2. Examine the package for excess packaging material (i.e., packaging tails). Fold the packaging material consistent with design of the packaging and tape the material securely to the package so that its effect on the dimensional measurement is minimized. If the thickness of packaging tail appears excessive, it is appropriate to determine its average thickness by making at least three measurements along its length using a dead weight dial micrometer specified in Section 4.5. “Polyethylene Sheeting” and subtract the thickness from the measurement of length, width or height. Any deduction from a measurement should be noted on the inspection report.**
- 3. If a Dimensional Measuring Frame is used, place it on a solid support. If a table is used, select one of sufficient load capacity to hold the weight of the frame and the heaviest package to be tested.**
- 4. Position the frame so that the zero end of the ruler can be placed squarely and firmly against a surface of the frame and so that the ruler graduations can be read. Position yourself so that you can read both the ruler and the edge of the carpenter square in Exhibit 2.**
- 5. Place the package against two sides of the frame without compressing the package. Place a carpenter square against the package at the point of measurement and align the ruler perpendicular to the edge of the carpenter square as shown in Exhibit 3 where the package length and Exhibit 4 where the package height are being determined.**

**Using a Measuring Frame for Dimensional Testing**  
**Ruler and Carpenter Square define Zero Reference and Measurement Point**



**Figure 3-2(b). The rigid frame allows the observer to hold the zero reference point firmly in place.**



**Figure 1-4. Length Measurement.**



**Figure 3-5. Height Measurement – A packaging tail on the end of the package can affect this measurement so it has been folded over and taped against the end of the package.**



**Figure 3-6. Width Measurement – the frame is rotated on its end to vertical so that the carpenter square does not compress the product.**

**6. Measurements – take at least five measurements\* of each of the dimensions as follows:**

**\*On small packages (height or length dimensions of 152 mm [6 in] or less) at least three measurements are taken using the following the instructions).**

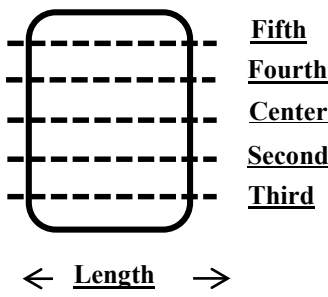
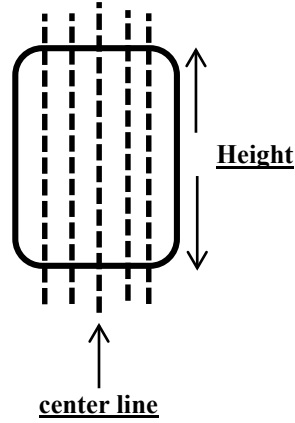
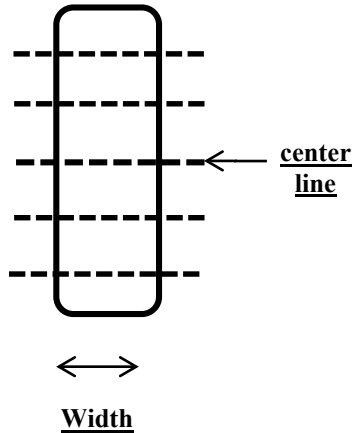
<b>Inspect the package for shape and place the flattest surfaces against the measuring frame.</b>	
<p><b>i.</b></p>	<p><b><u>Length (see Exhibit 3):</u></b></p> <ol style="list-style-type: none"> <li>a. <u>take the first measurement across the center line of the Length axis of package.</u></li> <li>b. <u>take the second measurement at half the distance between the center Line and either of the package edges.</u></li> <li>c. <u>take the third measurement half the distance between the second measurement and the package edge.</u></li> <li>d. <u>take the fourth measurement on the opposite end of the package at half of the distance between the center line and the package edge.</u></li> <li>e. <u>take the fifth measurement at half of the distance between the fourth measurement and the package edge.</u></li> </ol>
	
<p><b>ii.</b></p>	<p><b><u>Height: (see Exhibit 4):</u></b></p> <ol style="list-style-type: none"> <li>a. <u>take the first measurement across the center line of the Height axis of the package.</u></li> <li>b. <u>take the second measurement at half the distance between the center line and the package edge.</u></li> <li>c. <u>take the third measurement half the distance between the second measurement and the package edge.</u></li> <li>d. <u>take the fourth measurement on the opposite end of the package at half of the distance between the center line and the package edge.</u></li> <li>e. <u>take the fifth measurement at half of the distance between the fourth measurement and the package edge.</u></li> </ol>
	
<p><b>iii.</b></p>	<p><b><u>Width: (see Exhibit 5): If using one, turn the measuring frame on end and place the package on its bottom and against the frame as shown in the picture and on the right where the package width is being measured.</u></b></p> <ol style="list-style-type: none"> <li>a. <u>take the first measurement across the center line of Width axis of the package.</u></li> <li>b. <u>take the second measurement at half the distance between the center line and the package edge.</u></li> <li>c. <u>take the third measurement half the distance between the second measurement and the package edge.</u></li> <li>d. <u>take the fourth measurement on the opposite end of the package at half of the distance between the center line and the package edge.</u></li> <li>e. <u>take the fifth measurement at half of the distance between the fourth measurement and the package edge.</u></li> </ol>
	

7. Record the dimensions of each package in millimeters in a software program or inspection form that includes the information shown in the sample worksheet “Calculate the Compressed Volume of the Package in Liters” (below). Enter the measurements in the appropriate spaces and calculate the volume in liters. Calculate the package error by following the steps listed in the table and then calculate the average error for the sample.

Note: The following table is an example of the information from an actual test that is included in a worksheet for verifying the compressed volume on packages of peat moss. The Inspection Worksheet for Dimensional Testing (see Appendix C) has space for a sample of 12 packages and includes the steps for calculating the Average Package Error. Here, the package error in the dimensional volume was + 6.8 L (+ 0.24 ft<sup>3</sup>). To determine the value of the MAV look up the labeled quantity in Appendix A, Table 2-6. Maximum Allowable Variations for Packages Labeled by Liquid and Dry Volume.

<b>SAMPLE WORKSHEET</b>			
<b>Calculate the Compressed Volume of the Package in Liters</b>			
<u>Unit of Measure = 1.0 mm</u>	<u>Length (L)</u>	<u>Width (W)</u>	<u>Height (H)</u>
<u>1.</u>	<u>482</u>	<u>282</u>	<u>690</u>
<u>2.</u>	<u>490</u>	<u>278</u>	<u>690</u>
<u>3. (Center Line)</u>	<u>493</u>	<u>276</u>	<u>681</u>
<u>4.</u>	<u>499</u>	<u>272</u>	<u>677</u>
<u>5.</u>	<u>493</u>	<u>269</u>	<u>657</u>
<u>a.</u> <u>Average:</u>	<u>491</u>	<u>275.4</u>	<u>679</u>
<u>b.</u> <u>L × W × H = Volume/1 000 000</u>	<u>91.8 L</u>		
<u>c.</u> <u>Labeled Compressed Quantities:</u>	<u>85 L</u>	<u>NA cu in</u>	<u>3.0 cu ft</u>
<u>d.</u> <u>Conversion Factors</u>	<u>NA</u>	<u>(b) × 61.02374</u>	<u>(b) × 0.03531467</u>
<u>e.</u> <u>Converted Volume</u>	<u>85 L</u>	<u>NA cu in</u>	<u>3.24 cu ft</u>
<u>f.</u> <u>Package Error = (b – c)</u>	<u>6.8 L</u>	<u>NA cu in</u>	<u>0.24 cu ft</u>

### 3.9.2. Uncompressed Volume Packages

Use the following method to test peat moss sold using an uncompressed volume as the declaration of content. The procedure as defined by the latest version of ASTM D2978-03, “Standard Test Method for Volume of Processed Peat Materials.”

#### 3.9.2.1. Test Equipment

- 12.7 mm (or ½ in) sieve
- Use ~~a one of the following~~ test measure appropriate for the package size. (Refer to Table 3-4. “Specifications for Test Measures for Mulch and Soils” for additional information on test measure size and construction.)

➤ ~~28.3 L (1 ft<sup>3</sup>) measure with inside dimensions of 30.4 cm (12 in) by 30.4 cm (12 in) by 30.4 cm (12 in). Mark the inside of the measure with horizontal lines every 1.2 cm (½ in) so that package errors can be directly determined~~

- ~~100 L (3.5 ft<sup>3</sup>) measure with inside dimensions of 50 cm (19.68 in) by 50 cm (19.68 in) by 40 cm (15.74 in). The inside of the measure should be marked with horizontal lines every 1.2 cm (½ in) so that package errors can be directly determine~~

- Straight edge, 50.8 cm (20 in) in length
- Sheet for catching overflow of material
- Level (at least 15.24 cm (6 in) in length)

### 3.9.2.2. Test Procedure

1. Follow Section 2.3.1. “Define the Inspection Lot.” Use a “Category A” sampling plan in the inspection; select a random sample.
2. Open each package in turn, remove the contents, and pass them through the sieve directly into the measuring container (overfilling it). Use this method for particulate solids (such as soils or other garden materials) labeled in cubic dimensions or dry volume. Some materials may not pass through the sieve for peat moss; in these instances, separate the materials by hand (to compensate for packing and settling of the product after packaging) before filling the measure.

**Note:** Separated material (product not passing through the sieve) must be included in the product volume.

3. Shake the measuring container with a rotary motion at one rotation per second for five seconds. Do not lift the measuring container when rotating it. If the package contents are greater than the measuring container capacity, level the measuring container contents with a straightedge using a zigzag motion across the top of the container.
4. Empty the container. Repeat the filling operations as many times as necessary, noting the partial fill of the container for the last quantity delivered using the interior horizontal markings as a guide.
5. Record the total volume.
6. To compute each package error, subtract the labeled quantity from the total volume and record it.

### 3.9.3. Evaluation of Results

Follow the procedures in Section 2.3.7. “Evaluate for Compliance” to determine lot conformance for either procedure.

**Note: To determine the value of the MAV look up the labeled quantity in Appendix A, Table 2-6. Maximum Allowable Variations for Packages Labeled by Liquid and Dry Volume.**

#### **Background/Discussion:**

This proposal will provide a standardized test method that will improve measurement accuracy at the point of pack and in testing at other locations. The test procedure recommends the use of a gravimetric audit procedure that may reduce destructive testing and reduce inspection time.

Although some existing test measures may still be used, this proposal encourages users to purchase the prescribed volumetric test measures, chutes, and measuring instruments.

The NIST, OWM will develop and provide technical training on this subject matter and develop detailed equipment designs and drawings, which will be made available on the NIST, OWM website. The OWM will assist the peat moss industry in implementing the proposed method of sale as well as developing and incorporating good manufacturing practices to ensure that the requirements of NIST Handbook 133 are met.

NCWM 2015 Interim Meeting: The Committee agreed that Sections 3.9.1 and 3.9.1.a. need to be removed from the language. The Committee agreed any term related to “animal bedding” should also be removed to align with Item 232-3. The NIST Technical Advisor remarked that the background information is being reviewed for formatting by the office Publication Coordinator and advised that no technical changes were being made and would be resubmitted with NCWM Publication 16 (2015). The 2015 L&R Committee agreed to move this forward as a Voting item.

NCWM 2015 Annual Meeting: The Committee deleted figure 3.1 since NIST has provided detailed pictures within the test procedure. In Section 2.9.1.2., Step 7. Note: the line “Apply a tentative MAV of 5 % to a dimensional measured volume was stricken. It was replaced with “To determine the value of the MAV look up the labeled quantity in Appendix A., Table 2-6. Maximum Allowable Variations for Packages labeled by Liquid and Dry Volume.”

Refer to Appendix C., “Testing Packages of Animal Bedding and Peat Moss with Compressed and Expanded Volume Declarations” for the Executive Summary, additional background, forms, and supporting information.

#### **Regional Association Comments:**

NEWMA 2014 Interim Meeting: The L&R Chairman stated that NIST, OWM had submitted considerable information to the regions for review. This is one of a number of proposals that represents a large amount of work done at NIST to provide more consistent standards. An industry representative commented that he participated in the development of this proposal, and said industry has had a long-term struggle with various standards for both compressed and non-compressed packaging. He said these new procedures would allow for more accurate and easier testing in the field. He indicated that removal of the “compressed” description is important, because a consumer needs to know the usable amount of volume inside the package. These new procedures will minimize destructive testing, and will cover testing of new products in the market place. He strongly supports the proposal. A regulator asked if this procedure would include pelletized product. The industry representative indicated it would cover those products. Another regulator asked if compressed product would be broken up or crushed in the compressing process, and would, therefore, settle out to net a different volume. The industry representative explained there is a certain amount of destruction, so the usable volume will generally be slightly less than the volume statement. A regulator expressed support for this item to allow for clear and easy understanding by the consumer. Another regulator asked a question about the chute design during the test procedure. The industry representative explained that one of the challenges in testing volume is the amount of variability depending on the raw material you are starting with. He further explained the chute allowed for more consistency among and between products and repeated testing. NEWMA forwarded the item to NCWM and recommended that this be a Voting item.

NEWMA 2014 Annual Meeting: This item was considered in conjunction with Items 232-3 and 260-3. The Committee would like the work “tentative” stricken from the MAV values and considers this item fully developed.

SWMA 2014 Meeting: The Committee heard an overview of the changes being suggested from NIST. The Committee also heard that the requirement to put a compressed statement on a package was unnecessary and not very useful to the end user. The recoverable volume is what the customer uses. This would remove animal bedding from the test method in its entirety. The Committee heard that the test procedures are ready. It was also noted that the illustrations be changed to depict peat moss. SWMA forwarded the item to NCWM, recommending it as a Voting item.

Additional letters, presentations, and data may have been part of the Committee’s consideration. To review the supporting documentation, please refer to the *Report of the 99<sup>th</sup> National Conference on Weights and Measures* (SP1193, 2014).



**260-3 V Section 3.15. Test Procedure for Verifying the Usable Volume Declaration on Packages of Animal Bedding**

(This item was moved to Informational status.)

**Source:**

NIST Office of Weights and Measures (2015)

**Purpose:**

Add a test procedure in NIST Handbook 133, Section 3.15. Test Procedure for Verifying the Usable Volume Declaration on Packages on Animal Bedding. This test procedure will be used for verifying the compressed volume and usable (uncompressed) volume on packages of animal bedding.

**Item Under Consideration:**

Amend NIST Handbook 133 as follows:

**Section 3.15. Test Procedure for Verifying the Usable Volume Declaration on Packages of Animal Bedding**

**3.15.1. Test Equipment**

- **Calculator or Spreadsheet Software**
- **Modified Standard Package Report Form – Appendix D (at end of report).**
- **Package Inspection Worksheet Appropriate for Test Measure:**
  - **Appendix A – 26 Point Measurement Grid and Package Error Worksheet for Cylindrical Test Measures (at the end of the report)**
  - **Appendix B – 25 Point Measurement Grid and Package Error Worksheet for Square or Rectangular Test Measures (at the end of the report)**
- **Permanent Ink - Marking Pen.**
- **Knife or Razor Cutter (for use in opening packages and unwrapping shrink-wrapped pallets in warehouses)**
- **Cellophane Tape, Duct Tape (for repairing chutes and sealing packages)**
- **Polyethylene Bags (49 L to 113.5 L [13 gal to 30 gal]) (to hold product once it is uncompressed)**
- **Rigid Rulers – Starrett<sup>2</sup> or equal with 1.0 mm graduations. The edges of a ruler used with a measuring frame must be straight and the edges must be the zero point (see Exhibit 2).**
  - **300 mm (12 in)**
  - **500 mm (19.5 in)**

---

**<sup>2</sup> Notice: The mention of trade or brand names does not imply endorsement or recommendation by the U.S. Department of Commerce over similar products available from other manufacturers.**

- 1 m (39 in)
- Tarp - Canvas 3 m × 3 m (10 ft × 10 ft)
- Broom and Dust Pan
- Levels – for verifying the level of the test measure and taking headspace readings.
  - 152 mm (6 in) Bubble Level
  - 1 m (40 in) Carpenter Level
- Scale 15 kg (30 lb) (only used if the audit procedure is utilized.)
- Chutes for Uncompressing and Pouring the Bedding into a Test Measure

**Table 1.  
Recommended Chute Dimensions**

<u>Nominal Capacity</u>	<u>Height</u>	<u>Width</u>	<u>Length</u>
<u>70 L (2.5 ft<sup>3</sup>)</u>	<u>254 mm (10 in)</u>	<u>228 mm (9 in)</u>	<u>1219 mm (48 in)</u>
<u>100 L (3.5 ft<sup>3</sup>)</u>	<u>254 mm (10 in)</u>	<u>279 mm (11 in)</u>	<u>1397 mm (55 in)</u>
<u>170 L (6 ft<sup>3</sup>)</u>	<u>279 mm (11 in)</u>	<u>355 mm (14 in)</u>	<u>1727 mm (68 in)</u>
<u>240 L (8.5 ft<sup>3</sup>)</u>	<u>304 mm (12 in)</u>	<u>406 mm (16 in)</u>	<u>2006 mm (79 in)</u>
<u>283 L (10 ft<sup>3</sup>)</u>	<u>304 mm (12 in)</u>	<u>406 mm (16 in)</u>	<u>2286 mm (90 in)</u>

**NOTE: Chutes (see examples below) may be constructed using hinges and pins so that they lie flat for transporting. They can be constructed of sheet metal or with other slick surface material which enable the bedding to flow easily. The construction of the chutes used in this study allows the sides to move in or out slightly so that the bedding does not become clogged at the outlet. The heights and lengths may be adjusted slightly to fit into vehicles for transport but the widths should not be reduced because narrowing the opening can restrict material flow and result in “bridging” where the bedding collects and creates a block. Also, the width should be kept smaller than the opening of the test measure so that spillage does not occur during pouring.**



**Figure 2. Testing Chutes.**

- **Test Measures (see Table 2. “Test Measures for Animal Bedding”)**

**Table 2. Test Measures for Animal Bedding** NOTES: a, b, c, and d  
**Only Interior Dimensions Are Used for Volume Calculations**  
**Must Be Calibrated with Traceable Measurement Standards Prior to Use**

<b>Rectangular &amp; Square Test Measures</b>						
<b>Actual Volume of the Measure<sup>b &amp; d</sup></b>	<b>Interior Wall Dimensions</b>			<b>Surface Area</b>	<b>Marked Increments on Ruler</b>	<b>Increment Volume</b>
	<b>Length</b>	<b>Width</b>	<b>Height<sup>d</sup></b>			
<u>31.9 L</u> <u>1.13 ft<sup>3</sup></u>	<u>213.4 mm</u> <u>(8.4 in)</u>	<u>203.2 mm</u> <u>(8 in)</u>	<u>736.6 mm</u> <u>(29 in)</u>	<u>43 362 mm<sup>2</sup></u> <u>(67.2 in<sup>2</sup>)</u>	<u>12.7 mm</u> <u>(0.5 in)</u>	<u>550.6 mL*</u> <u>0.55 L</u> <u>(33.6 in<sup>3</sup>)</u>
<u>28.3 L</u> <u>1 ft<sup>3</sup></u>	<u>304.8 mm</u> <u>(12 in)</u>	<u>304.8 mm</u> <u>(12 in)</u>	<u>304.8 mm</u> <u>(12 in)</u>	<u>92 903 mm<sup>2</sup></u> <u>(144 in<sup>2</sup>)</u>		<u>1.18 L**</u> <u>(72 in<sup>3</sup>)</u>
<u>63.7 L</u> <u>2.25 ft<sup>3</sup></u>	<u>304.8 mm</u> <u>(12 in)</u>	<u>304.8 mm</u> <u>(12 in)</u>	<u>685.8 mm</u> <u>(27 in)</u>			
	<u>406.4 mm</u> <u>(16 in)</u>	<u>228.6 mm</u> <u>(9 in)</u>	<u>685.8 mm</u> <u>(27 in)</u>			
<u>92 L</u> <u>3.25 ft<sup>3</sup></u>	<u>304.8 mm</u> <u>(12 in)</u>	<u>304.8 mm</u> <u>(12 in)</u>	<u>990.6 mm</u> <u>(39 in)</u>			
	<u>406.4 mm</u> <u>(16 in)</u>	<u>228.6 mm</u> <u>(9 in)</u>	<u>990.6 mm</u> <u>(39 in)</u>			
<u>*1.0 mm = 43 mL (2.6 cu in)** 1.0 mm = 92 mL or 0.09 L (5.6 cu in)</u>						
<b>Square Test Measures</b>						
<b>Actual Volume of the Measure<sup>b &amp; d</sup></b>	<b>Interior Wall Dimensions</b>			<b>Surface Area</b>	<b>Marked Increments On Ruler</b>	<b>Increment Volume</b>
	<b>Length</b>	<b>Width</b>	<b>Height<sup>d</sup></b>			
<u>77.4 L</u> <u>(2.73 ft<sup>3</sup>)</u>	<u>381 mm</u> <u>(15 in)</u>	<u>381 mm</u> <u>(15 in)</u>	<u>533.4 mm</u> <u>(21 in)</u>	<u>145 161 mm<sup>2</sup></u> <u>(225 in<sup>2</sup>)</u>	<u>1.0 mm</u> <u>(0.03937 in)</u>	<u>0.14 L</u> <u>(8.5 in<sup>3</sup>)</u>
<u>144 L</u> <u>(5.09 ft<sup>3</sup>)</u>	<u>508 mm</u> <u>(20 in)</u>	<u>508 mm</u> <u>(20 in)</u>	<u>558.8 mm</u> <u>(22 in)</u>	<u>258 064 mm<sup>2</sup></u> <u>(400 in<sup>2</sup>)</u>		<u>0.25 L</u> <u>(15.2 in<sup>3</sup>)</u>
<u>283 L</u> <u>(10 ft<sup>3</sup>)</u>	<u>609.6 mm</u> <u>(24 in)</u>	<u>609.6 mm</u> <u>(24 in)</u>	<u>762 mm</u> <u>(30 in)</u>	<u>371 612 mm<sup>2</sup></u> <u>(576 in<sup>2</sup>)</u>		<u>0.37 L</u> <u>(22.5 in<sup>3</sup>)</u>

This publication is available free of charge from: <https://doi.org/10.6028/NIST.SP.1210>

**Table 2. Test Measures for Animal Bedding** NOTES: a, b, c, and d  
Only Interior Dimensions Are Used for Volume Calculations  
Must Be Calibrated with Traceable Measurement Standards Prior to Use

<u>Cylindrical Test Measures</u>					
<u>These dimensions are based on the tube having a ¼ inch wall thickness. Other tube thicknesses may be used.</u>					
<u>Actual Volume</u> <i>Volume = <math>\pi r^2 h</math></i>	<u>Interior Diameter</u> <u>(Outside Diameter)</u>	<u>Height</u>	<u>Surface Area</u> <i>Area = <math>\pi r^2</math></i>	<u>Increment</u>	<u>Increment Volume</u>
<u>52 L</u> <u>(1.8 ft<sup>3</sup>)</u>	<u>292.1 mm (304.8 mm)</u> <u>11.5 in (12 in)</u>	<u>780 mm</u> <u>(30.70 in)</u>	<u>67 012 mm<sup>2</sup></u> <u>(103.8 in<sup>2</sup>)</u>	<u>1.0 mm</u> <u>(0.03937</u> <u>in)</u>	<u>0.06 L</u> <u>(4 in<sup>3</sup>)</u>
<u>124 L</u> <u>(4.3 ft<sup>3</sup>)</u>	<u>444.5 mm (457.2 mm)</u> <u>17.5 in (18 in)</u>	<u>800 mm</u> <u>(31.49 in)</u>	<u>155 179 mm<sup>2</sup></u> <u>(240.52 in<sup>2</sup>)</u>		<u>0.15 L</u> <u>(9.4 in<sup>3</sup>)</u>
<u>279 L</u> <u>(9.8 ft<sup>3</sup>)</u>	<u>596.9 mm (609.6</u> <u>mm)</u> <u>23.5 in (24 in)</u>	<u>1000 mm</u> <u>(39.37 in)</u>	<u>279 829 mm<sup>2</sup></u> <u>(433.76 in<sup>2</sup>)</u>		<u>0.27 L</u> <u>(16.4 in<sup>3</sup>)</u>

**Notes for Table 2:**

- a. Rectangular and Square Based Dry Measures are typically constructed of 12.7 mm to 19.05 mm (0.5 in to 0.75 in) Marine Plywood. A 4.76 mm (<sup>3</sup>/<sub>16</sub> in) transparent sidewall is useful for determining the level of fill, but must be reinforced or be made of thicker material if it distorts when the measure is filled. If the measure has a clear front, place the level gage at the back (inside) of the measure so that the markings are read over the top of the animal bedding. Any of these measures may be made without an attached bottom for ease of emptying if they are placed on a solid level base during filling and measurement.
- b. Other size measures may be used if calibrated and the volume equivalence of the increment of 1.0 mm is no greater than 1/6 the MAV. Widening the base of a measure reduces the column height of the product and will reduce compression but the trade-off is that the larger surface area increases the volume so the potential for measurement errors increase. One of the benefits of the cylindrical design is that, in addition to eliminating the 90 degree angles of the corners where gaps in fill frequently occur, the surface area of a cylinder is less than an equal volume square measure and that results in better resolution in the volume measurements (i.e., compare the readability of a 24 in sq box which has a surface area of 576 in<sup>2</sup>, to the 24 in cylinder which has a surface area of 433 in<sup>2</sup>). The height of the test measure may be reduced, but this will limit the volume of the package that can be tested.
- c. If lines are marked in any test measures, they should extend around all sides of the measure if possible to improve readability. It is recommended that a line indicating the MAV level also be marked to reduce the possibility of reading errors when the level of the product is at or near the MAV.
- d. If the measures are built to the dimensions shown above, the actual volume of most of the measures will be larger than the nominal volume so that plus errors (overfill) can be measured accurately.

**3.15.2. Test Procedure****Test Notes:**

**Rounding: When a volume measurement falls between graduations on a ruler, round the value in the direction that favors the packer. This practice eliminates the issue of rounding from the volume determination and provides packagers the benefit of the doubt. The ruler graduation is 1.0 mm so the rounding error will be limited to 0.5 mm or less. It is good practice to circle a measurement that has been rounded up or make a statement to such effect so that it becomes a part of the inspection record.**

**Safety:**

**This procedure does not address all of the safety issues that users need to be aware of in order to carry out the following tasks. Users are sometimes required to conduct test in warehouse spaces or retail stores where fork-trucks are in motion – care must be taken to warn others to avoid or exercise care around the test site. The procedure requires users to lift heavy objects including large bulky packages and test measures and includes the use of sharp instruments to obtain packages from shrink-wrapped pallets. Users may be required to climb ladders or work platforms to obtain packages. When opening and emptying packages, dust, and other particles may be present or escape from the packages which may cause eye injuries and respiratory or other health problems. Users must utilize appropriate safety equipment and exercise good safety practice. If safe working conditions cannot be ensured, suspend testing until the situation is corrected.**

- 1. Follow the Section 2.3.1. “Define the Inspection Lot” select “Category A, Sampling Plan” in this inspection. Determine the Sample Size based on the size of the Inspection Lot using Category A. Collect the sample packages from the Inspection Lot using Section 2.3.4. “Random Sampling Selection.”**

**Test Note: Place the test equipment and sample packages in a location where there is adequate lighting and ample space around the packages and equipment so the packages can be opened and the chutes and test measures used safely.**

**Optional – Audit Screening by Weight**

**The full test procedure requires that all of the packages be opened for testing. Regardless of the type of bedding, the product cannot be returned to the original package. An alternative gravimetric auditing procedure may be used to reduce the amount of destructive testing and conserve inspection resources.**

**Audit Procedure: After randomly selecting the sample packages from the Inspection Lot, obtain the gross weight for each package. Select the lightest and heaviest packages and conduct a usable volumetric test these two packages. If the lightest and heaviest packages pass (i.e., each contains at least the useable volume declared on the label), it is highly likely that the remaining packages in the sample will also pass. Accept these two package samples as an AUDIT TEST and move on to inspect other types of bedding or Inspection Lots of other types or brands of bedding. If either of the two packages is found to have a minus error that exceeds the Maximum Allowable Variation, the sample fails. No further testing is required (i.e., assuming no MAV is allowed for the sample size (see Appendix A, Table 2-1. “Sampling Plans for Category A.”) If either of the packages is found to have a minus error that does not exceed**

**the MAV, continue to test all of the packages and take action based on the final results from the complete sample.**

**Test Note: If the gravimetric audit procedure is used, ensure that the scale is placed on a solid level support and that its accuracy has been verified to a test load that is at least 10 % more than the gross weight of the packages (e.g., to estimate that load, place one of the packages on the scale and then test the scale with a load above the package's gross weight). See Section 2.2. "Measurement Standards and Test Equipment" for additional information.**

2. **Select the appropriate test measure for the package size.**
  - **Spread a tarp large enough to hold a chute and test measure.**
  - **Place the chute and test measure on the tarp. Verify that the test measure is level.**
3. **Select a chute of appropriate capacity (see Table 1) for the package size and position it on the tarp.**
4. **Open the Packaging, Uncompressing and Pouring the Bedding into the Test Measure Twice.**
  - **Open Package: Place the package in the chute and use a knife or box cutter to open and remove the wrapper. Spread the bedding uniformly along the length of the chute. The bedding is uncompressing in two steps. The first step is to loosen the clumps of bedding by gently pulling them apart (do not tear the fibers of cellulose bedding or "grind" any bedding between your hands because these practices break the material down). Spread your fingers and pick the material up using your hands from beneath to loosen it up. There should be no clumps of bedding in the chute. If any bedding has fallen out of the chute onto the tarp, collect it and return it to the chute. The following pictures illustrate this step of the procedure. The second step of the expanded volume recovery process is to pour the bedding into a test measure as described in Step 2.**

**Exhibit 1.**



**Exhibit 2.**



**Exhibit 3. First pour into the test measures.**



- **First Pour: The first pour into the test measure is only used to further un-compress the bedding so no measurements are taken. Hold the chute above the test measure and tilt it so that you pour the bedding into the center of the test measure. The bedding should be poured slowly into the test measure in one continuous stream and not “dumped” (if it is “dumped” or poured too quickly some of the bedding will blow out of the measure or the bedding will be packed down and its volume reduced). The flow rate should be controlled by the tilt angle of the chute. The chute itself can be shaken but DO NOT HIT OR SHAKE THE TEST MEASURE. (Do not adjust the flow by closing the opening of the chute as that may cause the bedding to heap up and then fall into the measure in clumps which may result in impact compression). Empty the bedding back into the chute and spread it out evenly along its length.**



**Exhibit 4. Showing how to hold a chute for the pour.**



**Exhibit 2. Showing how to cradle the chute on one arm and holding it with one hand while tilting it with the other hand.**

- **Second Pour: The second pour into the test measure is used to make the volume determination. Hold the chute above the test measure and tilt it so that you pour the bedding into the center of the test measure. The bedding should be poured slowly into the test measure in one continuous stream and not “dumped.” The flow rate**



**should be controlled by the tilt angle of the chute. The chute can be shaken but DO NOT HIT OR SHAKE THE TEST MEASURE.**

**Test Note: Stop filling the measure if it appears that the test measure will overflow. The overflow product should be measured separately (use a smaller test measure of adequate size and capacity if one is available) and the multiple measurement volumes are added. If pouring into a square test measure, pour at an angle to two corners for the widest opening (see Exhibit 12).**



**Exhibit 6. Filling a 44 L Test Measure.**



**Exhibit 7. Filling a Square Test Measure at an Angle to use the Larger Opening.**

**5. Volume Determination.**

**DO NOT HAND LEVEL THE SURFACE OF THE BEDDING AS MANUAL LEVELING “PACKS” THE BEDDING AND REDUCES ITS VOLUME. DO NOT JAR OR SHAKE THE TEST MEASURE**

**Test Note: Before using a test measure for volume determinations, place a level of adequate length on top of the test measure at five approximately equal measuring points across the top. A permanent marking pen can be used to evenly space the marks across the top edge of the test measure so that it can be positioned to take the measurements (see Exhibit 13).**



**Exhibit 3. Marking the evenly spaced measuring points across the top of the test measure.**

- **Place a rigid level or straight edge of adequate size on top the test measure and select a ruler of adequate length to reach to the lowest level of the top surface of the bedding. Start at the measuring points to your left or right, place the ruler against the side of the level, and hold it with either hand. The zero graduation is pointed down so the ruler can be lowered into the test measure for measurement. Lower the ruler into the test measure slowly until its end is at the surface level of the bedding (see Exhibits 14 and 15).**



**Exhibit 4. Placing ruler into the test measure with zero end down.**



**Exhibit 10. Ruler shown with zero end at surface of the bedding.**

- **Determine the depth of each measurement point from the surface of the bedding to the bottom edge of the straight edge and record the value in the appropriate space on the worksheet. Take a minimum of 25 measurements (at least 26 for cylindrical measures) across the top of the test measure in a grid pattern. Read the graduations on the ruler from a position that minimizes errors caused by parallax.**

**Table 2. Illustrations of Depth Determinations with Cylindrical Test Measures**



Figure 1. Shows how to read the depth of container.

The picture on the left (Figure1) shows how to read the depth from the bottom of the straightedge (top edge of measure) down to the bedding in a 44 L test measure from a position that reduces parallax. The graphic below (Figure 2) illustrates the actual worksheet with the headspace procedure on the 44 L cylinder test measure (its internal radius is 151 mm and its height is 610 mm). The bedding was poured into the test measure but not leveled. Then 26 measurements were made at the locations shown on the grid to determine the depth of the product from the top edge of the measure. The average of the 26 values was 500.7 mm which was subtracted from the height of the test measure to obtain 109.26 mm for the average height of the column of bedding in the measure.

The volume was calculated using:  $Volume\ in\ liters = \pi r^2 h$   
 $Pi) 3.14159265 \times 23035.69 \times 109.26\ mm = 7.90\ L^*$

\*After the calculation was completed the result was divided by 1 000 000 to obtain the volume in liters.

Figure 2 Illustration of Worksheet.

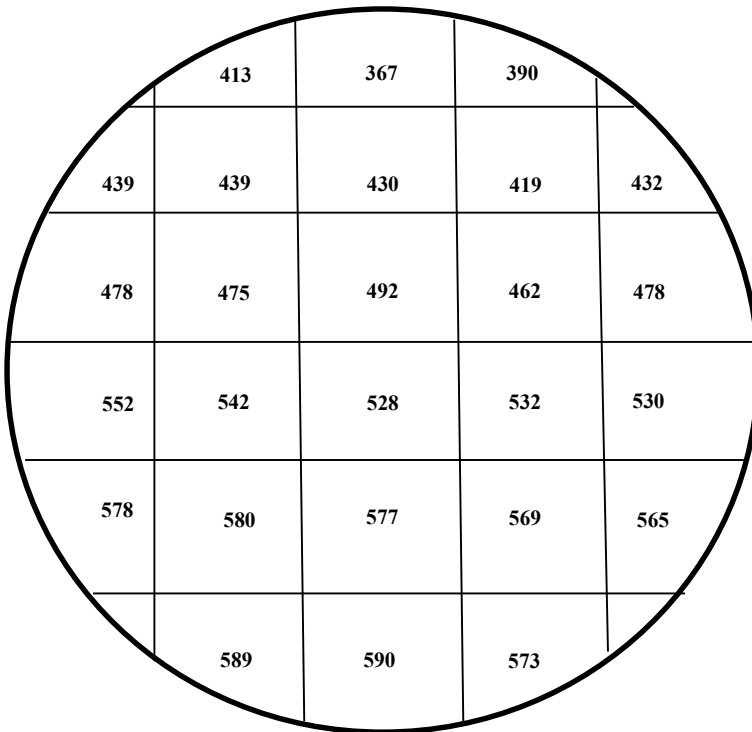

**Table 2. Illustrations of Depth Determinations  
with Cylindrical Test Measures**



**Figure 3. Using the headspace measurement on a 279 L test measure. The ruler is read from the bottom edge of a straight edge or level from a position that reduces parallax.**



**Figure 4. Illustrating how the ruler is placed on the bedding with the headspace method. The ruler is read from the bottom edge of a straight edge or level from a position that reduces parallax.**

**Table 3. Illustrations of Depth Determinations with Square Test Measures**



**Figure 1.**

<u>246</u>	<u>162</u>	<u>81</u>	<u>132</u>	<u>177</u>
<u>195</u>	<u>115</u>	<u>43</u>	<u>46</u>	<u>112</u>
<u>111</u>	<u>77</u>	<u>51</u>	<u>95</u>	<u>146</u>
<u>220</u>	<u>138</u>	<u>46</u>	<u>98</u>	<u>131</u>
<u>264</u>	<u>193</u>	<u>118</u>	<u>148</u>	<u>180</u>

**Figure 2.**

**The picture on the left (Figure 1) shows how to read the depth from the bottom of the straightedge (top edge of measure) down to the bedding in a 283 L square test measure from a position that reduces parallax. The graphic on the right (Figure 2) illustrates the actual worksheet with the headspace procedure on the square test measure (its internal dimensions are 609.6 mm × 609.6 mm × 762 mm (24 in × 24 in × 30 in). The bedding was poured into the test measure but not leveled. Then 25 measurements were made at the locations shown on the grid to determine the depth of the product from the top edge of the measure. The average of the 25 values was 133 mm that was subtracted from the height of the test measure to obtain 629 mm for the average height of the column of bedding in the measure.**

**The volume was calculated using: Volume in liters = lwh 609.6 mm × 609.6 mm × 629 mm = 233.74 L\***

**\*After the calculation was completed, the result was divided by 1 000 000 to obtain the volume in liters.**

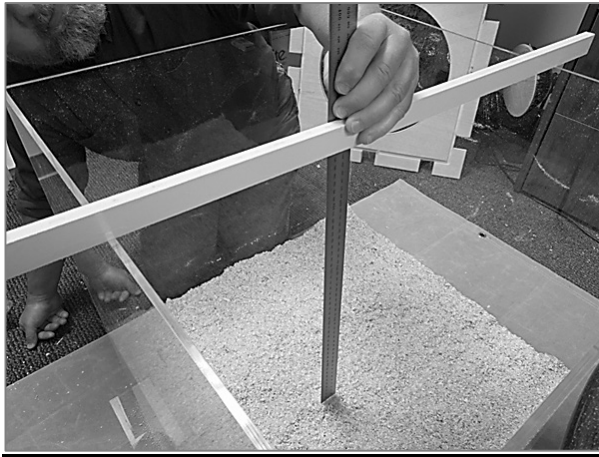

**Figure 3. Using the headspace measurement on 56.6 L (2 cu ft) test measure. The ruler is read from the bottom edge of a straight edge or level from a position that reduces parallax.**

**Table 3. Illustrations of Depth Determinations with Square Test Measures**

**Figure 4. Showing how the ruler is placed on the bedding with the headspace method. The ruler is read from the bottom edge of a straight edge or level from a position that reduces parallax.**

#### 6. Using a Worksheet for Volume Calculation

- Enter the sample number of the package on the worksheet along with its labeled usable volume.
- Test Measure Information
  - For a cylindrical test measure, enter its interior height and radius in the spaces labeled A and B.
  - For a square or rectangular test measure enter its interior height and the area of its base (i.e., length × width) in spaces labeled A and B.
- Sum the measurements in the grid, divide the value by the number of measurements (i.e., 25 or 26), and enter this value in the space labeled C, Average Depth.
- Calculate the Average Height of the Bedding (subtract C [Average Depth] from A [Interior Height of Test Measure]) and enter this value in the space labeled D.
- Calculate the Volume of Bedding in the Package:
  - For a cylindrical test measure, the formula ( $Volume\ in\ Liters = \pi r^2 h$ ) is shown in E on the worksheet. It is  $Volume\ (Liters) = 3.14159265 \times r^2 (B^2) \times Average\ Height\ (D) \div 1\ 000\ 000$ . Enter the package volume in the space provided for this value in E.
  - For a square or rectangular test measure the formula ( $Volume\ in\ Liters = LWH$ ) is shown in E on the worksheet. It is  $Volume\ (Liters) = B\ (Area\ of\ Test\ Measure\ Base) \times D\ (Average\ Height) \div 1\ 000\ 000$ . Enter the package volume in the space provided for this value in E.
- Calculate the Package Error using the following formula:
  - Package Error = Labeled Usable Volume (Liters) – E Package Volume (Liters)

$$\text{Package Error (Liters)} = \text{Labeled Expanded Volume} - \text{Package Volume}$$

- Transfer the individual package errors (verify whether they are positive or negative) to the “Modified Standard Package Report for Animal Bedding” in Appendix D. Fill in the required header information. For Box 7, “Number of Unreasonable Package Errors Allowed for Sample Size, use Appendix A, to Table 2-1. “Sampling Plans for Category A, Column 4.”, Based on the sample size, determine how many packages may have minus package errors that exceed the MAV (i.e., unreasonable package error).

Then:

- Calculate the Total Error (Enter in Box 8. “Total Error”).

#### 7. Evaluation of the Test Results and Determination of Pass or Fail

- Determine if any of the minus package errors exceeds the MAV. Apply a tentative MAV value of 5 % ( $0.05 \times$  labeled expanded volume) to single measurement volume determinations and a tentative MAV value of 10 % ( $0.10 \times$  labeled expanded volume) on multiple-measurement volume determinations (enter in Box 4 “MAV”). If none of the minus package errors exceeds the MAV, go to Step 3. If any of the minus package errors exceed the MAV, enter the number of packages in Box 9 “Number of Unreasonable Minus Errors”. Go to Box 10 “Is Box 9 Greater than Box 7?” and determine if the value exceeds the number in Box 7 “Number of Unreasonable Package Errors Allowed for Sample Size”. If the number of packages with unreasonable errors exceeds the number permitted in Box 7 “Number of Unreasonable Package Errors Allowed for Sample Size,” the sample fails. Go to Box 17 “Disposition of the Inspection Lot” and reject the Inspection Lot.
- Calculate the Average Error for the sample by dividing Box 8 “Total Error,” by Box 6 “Sample Size” and enter the value in Box 11 “Calculate Average Error,” then go Box 12 “Does Box 11 equal Zero or Plus?” If the Average Error is zero or a positive number the sample passes, go to Box 17 “Disposition of the Inspection Lot” and approve the inspection lot. If the Average Error is a negative value go to Step 4. If the Average Error is a negative value go to Step 4 on the Inspection Worksheet.
- Calculate the Sample Standard Deviation and enter in Box 13. 13 “Compute Sample Standard Deviation.” To obtain the Sample Correction Factor for the sample size use Appendix A, Table 2-1. “Sampling Plans for Category A,” Column 3 “Sample Correction Factor’ and enter that in Box 14 “Sample Correction Factor.” Then calculate the Sample Error Limit by multiplying Box 13 “Compute Sample Standard Deviation” and Box 14 “Sample Correction Factor.” Enter the value in Box 15 “Compute Sample Error Limit.”
  - Disregarding the signs, determine if the minus in Box 11 “Calculate Average Error” is larger than the value in Box 15 “Compute Sample Error Limit.”
  - If yes, the sample fails, go to Box 17 “Disposition of Inspection” and reject the Inspection Lot.
  - If no, the sample passes, go to Box 17 “Disposition of Inspection” and approve the Inspection Lot
- Prepare a comprehensive report of the test results and enforcement action taken and present the information to the party responsible for the product.

**Background/Discussion:**

This proposal will provide a standardized test method that will improve measurement accuracy at the point of pack and in testing at other locations. The test procedures recommend the use of a gravimetric audit procedure that may reduce destructive testing and reduce inspection time.

Even though some existing test measures may still be used the proposed procedure encourages users to purchase the prescribed volumetric test measures, chutes and measuring instruments.

The NIST, OWM will develop and provide technical training on this subject matter and develop detailed equipment designs and drawings which will be made available on its website. The OWM will assist the animal bedding industry in implementing the proposed method of sale as well as developing and incorporating good manufacturing practices to ensure that the requirements of NIST Handbook 133 are met.

NCWM 2015 Interim Meeting: Mr. Whiting (American Wood Fiber) spoke in support of this test procedure. Mr. Whiting worked closely with NIST, OWM on reviewing this test procedure and agrees this procedure has less variability, sensitivity, not time consuming, and is easier to perform in the field. A California county representative (regulator) suggested that the definition for animal bedding should account for wood shavings and chips. He also inquired about the results when the procedure is used to test ground corn and cat litter. It was also remarked that building a chute as specified and lifting it on shoulders and pouring needs to be examined. Could this be done with smaller chutes and multiple pours? Mr. Whiting, who has performed this procedure, remarked this may need two inspectors. He also stated animal bedding with dense particle size has better repeatability. The NIST Technical Advisor remarked that the background information provided by OWM is being reviewed for formatting by the office Publication Coordinator, advised that no technical changes were being made, and noted that it would be resubmitted with NCWM Publication 16 (2015). The 2015 L&R Committee agreed to move this forward as a Voting item.

NCWM 2015 Annual Meeting: It was noted by the NIST Technical Advisor that the term “expanded volume should read “usable volume” and the term “compressed” was deleted from the section title. There was discussion concerning clay products when using chutes. Concern was expressed regarding the cost of purchasing testing equipment. The reason for the various vessel sizes is due to the variety of package sizes in the marketplace. The term “expanded” was changed to “usable” throughout the proposal along with minor editorial changes. This item was moved from Voting to Informational status.

Refer to Appendix C. “Testing Packages of Animal Bedding and Peat Moss with Compressed and Expanded Volume Declarations” for the Executive Summary, additional background, and supporting information.

**Regional Association Comments:**

NEWMA 2014 Interim Meeting: The L&R Chairman stated that NIST, OWM had submitted considerable information for the regions to review. This is one of a number of proposals that represents a large amount of work done at NIST to provide more consistent standards. An industry representative commented that he participated in the development of this proposal, and said industry has had a long-term struggle with various standards for both compressed and non-compressed packaging. He said these new procedures would allow for more accurate and easier testing in the field. He indicated the removal of the term “compressed” from the descriptor is important, because a consumer needs to know the usable amount of volume inside the package. These new procedures will minimize destructive testing and will cover testing of new products in the market place. He strongly supports the proposal. A regulator asked if this procedure would include pelletized product. The industry representative indicated it would cover those products. Another regulator asked if compressed product would be broken up or crushed in the compressing process and would, therefore, settle out to net a different volume. The industry representative explained there is a certain amount of destruction, so the usable volume will generally be slightly less than the original volume. A regulator expressed support for this item to allow for clear and easy understanding by the consumer. Another regulator asked a question about the chute design during the test procedure. The industry representative explained that one of the challenges in testing volume is the amount of variability, depending on the raw material being used. He further explained the chute allowed for more consistency among and between products and repeated testing. NEWMA forwarded the item to NCWM and recommended that this be a Voting item.

NEWMA 2014 Annual Meeting: This item was considered in conjunction with Items 232-3 and 260-2. The Committee would like the word “tentative” stricken from the MAV values and considers this item fully developed.



SWMA 2014 Meeting: The Committee heard an overview of the changes being suggested from NIST. The Committee also heard that the requirement to put a compressed statement on a package was unnecessary and not useful to the end user. The recoverable volume is what the customer uses. The Committee heard that the test procedures are ready. SWMA forwarded the item to NCWM, recommending it as a Voting item.

Additional letters, presentations, and data may have been part of the Committee's consideration. To review the supporting documentation, please refer to the *Report of the 99<sup>th</sup> National Conference on Weights and Measures* (SP1193, 2014).

## 270 OTHER ITEMS

### 270-1 D Fuels and Lubricants Subcommittee

**Source:**

The Fuels and Lubricants Subcommittee (2007)

**Purpose:**

Update the Uniform Engine Fuels, Petroleum Products, and Automotive Lubricants Regulation in NIST Handbook 130 including major revisions to fuel ethanol specifications. Another task will be to update the Basic Engine and Fuels, Petroleum Products, and Lubricants Laboratory Publication.

**Item Under Consideration:**

This item is under development. All comments should be directed to Dr. Matthew Curran, FALS Chair at (850) 921-1570, [Matthew.Curran@freshfromflorida.com](mailto:Matthew.Curran@freshfromflorida.com), or Ms. Lisa Warfield, NIST Technical Advisor at (301) 975-3308, [lisa.warfield@nist.gov](mailto:lisa.warfield@nist.gov).

**Background/Discussion:**

The Subcommittee met on January 24, 2007, at NCWM Interim Meeting to undertake a review of a number of significant issues related to fuel standards. Their first project was to undertake a major review and update of the Uniform Engine Fuels, Petroleum Products, and Automotive Lubricants Regulation in NIST Handbook 130. The Subcommittee also met at the 2007 NCWM Annual Meeting and continued its work on a number of items in addition to preparing a major revision of the Fuel Ethanol Specifications. Since then, the Subcommittee has met regularly at the NCWM meetings, forming working groups to complete specific projects. An update on these projects is given below:

**Handbook 130 WG:** Mr. Jennings submitted to the FALS edits to Handbook 130 currently being proposed by his WG and asked the Subcommittee to begin considering the proposed changes now. The Handbook 130 WG plans to share the proposed changes with the regions over the course of the next year with the goal that NCWM consider voting on the changes at its 2016 NCWM Annual Meeting. Mr. Jennings then invited FALS members to consider joining the group and requested that a collaboration site on the NCWM website be established to allow interested parties to comment on the proposed changes. Dr. Curran agreed to send a request for a collaboration site to NCWM Executive Director.

**Renewable Diesel Labeling and Definitions WG:** Ms. Rebecca Richardson provided an update on the group's efforts to FALS. Ms. Richardson believes the group would benefit from additional involvement from engine manufacturers and refiners. Mr. Derek Regal from Tesoro volunteered to serve on the WG.

**CNG/LNG Equivalent Values WG:** Mr. Jeff Clarke updated FALS on the efforts and purpose of this WG to determine whether or not the diesel gallon equivalency conversion factor is accurate and added that the group has not reached consensus on the conversion factor. Mr. Clarke then reviewed the current values and historical energy values and ratios from various models.

**Organometallic WG:** Mr. Jeff Jetter (R&D Americas) provided a power point presentation on the work being done under the umbrella of the ASTM International Committee D02. The CRC has been commissioned to summarize the

volumes of data that have been posted on the NCWM Organometallic WG repository site. The CRC report is under review and should be released in the coming weeks. Mr. Randy Jennings (Tennessee) presented proposed changes relative to organometallics as a part of the Uniform Engine Fuel and Automotive Lubricants Regulation WG presentation. Currently, the proposed changes to the uniform regulation are labeling requirements based upon the Nevada and Tennessee rules. The route for NCWM will depend upon the outcome of the ASTM TG efforts. Mr. Jetter, Mr. Jennings, and Ms. Alyson Fick (ASTM International) provided a more detailed presentation on the collaboration between ASTM and NCWM at the NCWM Annual Meeting technical session.

Additional letters, presentations, and data may have been part of the Committee's consideration. To review the supporting documentation, please refer to the *Report of the 99<sup>th</sup> National Conference on Weights and Measures* (SP1193, 2014).

## 270-2 D Packaging and Labeling Subcommittee

### Source:

Packaging and Labeling Subcommittee (2011)

### Purpose:

Provide an update of the activities of this Subcommittee, which reports to the L&R Committee. The mission of PALS is to assist the L&R Committee in the development of agenda items related to packaging and labeling. The Subcommittee will also be called upon to provide important and much needed guidance to the regulatory and consumer packaging communities on difficult questions. PALS will report to NCWM L&R Committee. The Subcommittee is comprised of a Chairperson and eight voting members.

### Item Under Consideration:

This item is under Development. All comments should be directed to Mr. Chris Guay, Packaging and Labeling Subcommittee Chair at (513) 983-0530, [guay.cb@pg.com](mailto:guay.cb@pg.com) or Mr. David Sefcik, NIST Technical Advisor at (301) 975-4868, [david.sefcik@nist.gov](mailto:david.sefcik@nist.gov).

### Background/Discussion:

The Subcommittee is comprised of four regulatory officials (one from each region) and four from industry (retailers and manufacturers). Mr. Guay, PALS Chair, reported that work is currently being held through webinar meetings and at the NCWM meetings. PALS members are responsible for providing updates at their regional meetings. Mr. Guay added that PALS will be developing proposals and providing guidance and recommendations on existing proposals as assigned by the NCWM L&R Committee. He also stressed the need and importance of having key federal agencies (FDA, FTC, and USDA) participating.

Mr. Guay reported the Subcommittee is considering further development of the following items:

- **Additional Net Content Declarations on the Principal Display Panel** – Package net contents are most commonly determined by the product form, for example – solid products are labeled by weight and liquid products are labeled by volume. Semi-solid products such as pastes, creams, and viscous liquids are required to be labeled by weight in the United States and by volume in Canada.
- **Icons in Lieu of Words in Packages Labeled by Count** – Can a clear and non-misleading icon take the place of the word “count” or “item name” in a net content statement? While existing Federal regulation requires regulatory label information to be in “English,” the increasing presence of multilingual labels and the growing diversity of the U.S. population suggest more consumers are served with a clear and non-misleading icon.
- **Multilingual Labels**
- **Multipacks and Bundle Packages** – The net content statements for multipacks and bundled packages of individually labeled products can be different based on the approach used to calculate them. The difference is the result of the degree of rounding for dual U.S. customary unit and metric declarations. Using two

apparently valid but different methods can yield one net content statement result that provides better accuracy between the metric and inch-pound declarations, and a different net content result which is consumer friendly.

NCWM 2013 Interim Meeting: Mr. James Kohm (Director of Enforcement at the Federal Trade Commission [FTC]), briefed NCWM on the goals and objectives of FTC. Mr. Kohm gave a general overview of the Fair Packaging and Labeling Act (FPLA) and announced it is under review in 2013. Mr. Chris Guay provided an update on the action of PALS. PALS will be focusing on best practice principles for the various quantity and quality statements seen in the marketplace

NCWM 2014 Interim Meeting: Mr. Guay stated they are awaiting an announcement from FTC in regards to updating the FPLA regulations.

NCWM 2014 Annual Meeting: Mr. Guay reported that PALS had drafted and submitted comments in response to a Federal Register Notice requesting possible updates to FTC's Fair Packaging and Labeling Act regulations. PALS drafted 15 specific comments for FTC consideration, and these were submitted in May 2014. PALS reviewed the comments in detail during their Subcommittee session held on Sunday afternoon. FTC is now in the process of considering these and other comments and will issue a formal proposal to make changes within the next one to two years.

NCWM 2015 Interim Meeting: Mr. Guay reported that PALS was making progress on a Recommended Practice Document for quantity-related statements appearing on the package net content statement outside of the required statement of net quantity. He noted that no guidance or regulation exists for these types of statements and as a result, every manufacturer creates their own approach. A Recommended Practice Document is expected to help bring uniformity and consistency by providing a reference for these types of label statements. This document will either be a stand-alone document on the NCWM website or included as part of another NCWM publication.

NCWM 2015 Annual Meeting: Mr. Guay reported that FTC has recommended adoption of five of the amendments recommended by PALS into their final FPLA regulations. FTC also responded to each recommendation made by PALS. FTC did not propose adoption of amendments from any other source.

Mr. Guay and Ms. Angela Godwin (Ventura County, California) gave a presentation providing details of the developing Recommended Practice Document to build awareness and to get broader input on this item. The Subcommittee's goal is to have the document mostly done by early 2016 so that it can be refined and edited prior to the 2016 Annual Meeting. It is expected to be submitted for regional review in autumn 2016.

Additional letters, presentations, and data may have been part of the Committee's consideration. To review the supporting documentation, please refer to the *Report of the 99<sup>th</sup> National Conference on Weights and Measures* (SP1193, 2014).

### **270-3 D Moisture Allowance Task Group (MATG)**

**Source:**

Moisture Allowance Task Group (2012)

**Purpose:**

This Task Group will provide additional guidance for making moisture allowances for products not listed in NIST Handbook 133.

**Item Under Consideration:**

This item is under Development. All comments should be directed to Mr. Kurt Floren, Moisture Allowance Task Group Chair at (626) 575-5451, [kfloren@acwm.lacounty.gov](mailto:kfloren@acwm.lacounty.gov) or Ms. Lisa Warfield, NIST Technical Advisor at (301) 975-3308, [lisa.warfield@nist.gov](mailto:lisa.warfield@nist.gov)

**Background/Discussion:**

NCWM 2012 Interim Meeting: Ms. Judy Cardin, Committee Chair, will be requesting that the NCWM Board of Directors form a new Task Group to review moisture allowance. The 2012 L&R Committee designated this item as a Developing item.

NCWM 2012 Annual Meeting: Mr. Floren (Los Angeles County, California) announced that he will Chair the Moisture Allowance Task Group.

NCWM 2013 Interim Meeting: Mr. Floren announced that he is seeking a representative from each region for the MATG. Currently, the following regions have provided a representative; NEWMA, Mr. Frank Greene, (Connecticut) and the WWMA, Mr. Brett Gurney (Utah). The following individuals have expressed interest; Ms. Maile Hermida (Hogan Lovells US, LLP), Ms. Ann Boeckman (Kraft Foods Group), and Mr. Chris Guay (Procter and Gamble Co.). Mr. Floren remarked that meetings will be held via web-meetings and at the NCWM Conferences.

NCWM 2014 Interim Meeting: The MATG discussed how to move forward on this item and reviewed past history of prior work done. At the 2014 and 2015 NCWM Annual Meeting, Mr. Floren informed the Committee that there has been scheduling conflicts with other priorities this past year, and he has not had the opportunity to get a meeting scheduled. Mr. Floren would like the opportunity to continue chairing this TG and will pursue this item.

Additional letters, presentations, and data may have been part of the Committee's consideration. To review the supporting documentation, please refer to the *Report of the 99<sup>th</sup> National Conference on Weights and Measures* (SP1193, 2014).

---

Mr. Tim Lloyd, Montana | Committee Chair (absent at the 2015 NCWM Interim)  
 Mr. Richard Lewis, Georgia | Member (Acting Committee Chair – 2015 NCWM Interim)  
 Mr. Louis Sakin, Towns of Hopkinton/Northbridge, Massachusetts | Member  
 Mr. John Albert, Missouri | Member  
 Ms. Kristin Macey, California | Member  
 Mr. Steven Grabski, Walmart Stores | Associate Membership Representative (absent at the 2015 Annual)  
 Mr. Lance Robertson, Measurement Canada | Canadian Technical Advisor  
 Ms. Lisa Warfield, NIST, OWM | NIST Technical Advisor (absent at the 2015 Annual)

**Laws and Regulations Committee**

THIS PAGE INTENTIONALLY LEFT BLANK

## Appendix A

### Items 232-4 and 237-1: Handbook 130

#### **Background and Justification for Handbook 130 Definitions of “Diesel Gallon Equivalent (DGE)” of Compressed Natural Gas (CNG) and Liquefied Natural Gas (LNG) as a Vehicular Fuel**

##### **Clean Vehicle Education Foundation**

##### Development of the “Gasoline Gallon Equivalent” by NCWM\*

In 1993, under the auspices of the National Conference on Weights and Measures (NCWM), a Compressed Natural Gas (CNG) Working Group came together to determine the way in which CNG would be sold to the public at retail as a motor fuel.

The working group focused on three issues:

1. How to provide the Natural Gas Vehicle (NGV) industry a method of sale that would be familiar and acceptable to consumers
2. How to provide weights and measures officials a verifiable and quantifiable means to determine the accuracy of natural gas dispensers; and
3. How to meet these requirements with a uniform, national standard.

NCWM considered three proposals for the method of sale of CNG:

1. Joules, the unit of energy measurement in SI units
2. Mass
3. The Gasoline Gallon Equivalent (GGE)

The Natural Gas Vehicle Coalition (now NGV America) recommended that the Gasoline Gallon Equivalent be adopted as the method of sale for CNG, and that it be based on the energy equivalent of a gallon of gasoline. The use of the GGE was recommended primarily for the convenience of the retail customer comparing the cost and fuel economy of a natural gas vehicle to a comparable gasoline vehicle. During the discussion, a proposal was made to eliminate the reference to energy content of CNG and replace it with a fixed conversion factor based on mass, with the fixed mass of CNG being equal to a gallon of gasoline. Measurement of mass in the retail dispenser and

---

\* *Report of the 78<sup>th</sup> National Conference on Weights and Measures, 1993*, NIST Special Publication 854, pp 322-326.  
*Report of the 79<sup>th</sup> National Conference on Weights and Measures, 1994*, NIST Special Publication 870, pp 213-217.  
*Program and Committee Reports for the National Conference on Weights and Measures, 79<sup>th</sup> Annual Meeting, July 17-21, 1994*, NCWM Publication 16, pp 89-92.

verification by W&M officials is easier and less costly than measurement of energy content.

Since the energy content of a unit measure of CNG (standard cubic foot - scf) and gasoline (gallon) vary widely depending on the sample of fuel measured, the reference gallon of gasoline was determined to be Indolene, the gasoline used by EPA to certify emissions and fuel economy, with an energy content (lower heating value) of 114,118 BTU/gal. Work conducted by the Institute of Gas Technology and the Gas Research Institute (now combined into the Gas Technology Institute) surveyed 6,811 samples of natural gas nationwide and concluded that the “average” natural gas in the US had an energy content (lower heating value) of 923.7 BTU/scf, and a density of 0.0458172 lbs/cubic foot. This translates 20,160.551 BTU/lb. Dividing gasoline’s 114,118 BTU/gal by natural gas’s 20,160.551 BTU/lb gives 5.660 lbs of natural gas = 1 GGE. Similar calculations determined that a gasoline liter equivalent of natural gas equals 0.678 kg of natural gas.

At its 79<sup>th</sup> annual meeting in July of 1994, NCWM adopted resolutions that:

All natural gas kept, offered or exposed for sale or sold at retail as a vehicle fuel shall be in terms of the gasoline liter equivalent (GLE) or gasoline gallon equivalent (GGE), and

All retail natural gas dispensers shall be labeled with the conversion factor in terms of kilograms or pounds. The label shall be permanently and conspicuously displayed on the face of the dispenser and shall have either the statement “1 Gasoline Liter Equivalent (GLE) is equal to 0.678 kg of Natural Gas” or “1 Gasoline Gallon Equivalent (GGE) is equal to 5.660 lb of Natural Gas” according to the method of sale used.”

These statements can be found in NIST Handbook 130\*, along with the definition of “natural gas” which seems to apply only to Compressed Natural Gas, not to Liquefied Natural Gas. Handbook 130, §§3.11 and 3.12 (Engine Fuels, Petroleum Products, and Automotive Lubricants Regulations) confirm that these requirements are for CNG, rather than LNG. Similar requirements and definitions are found in Handbook 44.

During the discussions it was recognized that, although diesel and gasoline are both sold in gallon units, a gallon of diesel fuel has substantially more energy content than a gallon of gasoline. While it is convenient to use the Gasoline Gallon Equivalent unit when comparing the cost and fuel economy of gasoline-powered light-duty vehicles to equivalent natural gas vehicles, a Diesel Gallon Equivalent unit would be more useful for operators of medium and heavy-duty (usually diesel powered) vehicles. However, in 1994, the NCWM working group “agreed to defer development of a “Diesel Gallon Equivalent” until the issues related to the ‘Gasoline Gallon Equivalent’ were decided by the NCWM and agreed to meet again if additional work is necessary.”\*\* The issue of the

---

\* “Method of Sale Regulation,” §2.27

\*\* *Report of the 79<sup>th</sup> National Conference on Weights and Measures, 1994*, NIST Special Publication 870, p 214

formal definition a Diesel Gallon Equivalent (DGE) unit has not come before NCWM from that time until today, although the DGE is often used in the industry, defined as 6.31 lb of compressed natural gas.

*Need for a Definition of a “Diesel Gallon Equivalent” Unit*

Today there are an increasing number of commercial vehicles using natural gas as a fuel, to lower emissions and Greenhouse Gases, decrease America’s use of petroleum, and lower fuel costs (U.S. DOE Clean Cities Alternative Fuel Price Report for April 2012 shows in Table 2 ‘Overall Average Fuel Price on Energy-Equivalent Basis’ that diesel is priced at \$4.12/gal and CNG at \$2.32/gal [http://www.afdc.energy.gov/afdc/pdfs/afpr\\_apr\\_12.pdf](http://www.afdc.energy.gov/afdc/pdfs/afpr_apr_12.pdf)).

Since the NCWM’s working group deferred development of a DGE unit in 1994, there has been little call by the natural gas vehicle industry for the formalization of that unit in the sale of Compressed Natural Gas. However, the use of **Liquefied** Natural Gas (LNG) as a motor fuel has been growing (more than 350 LNG stations are being built on the nations interstate Highways) and there is significant interest in using the DGE as a unit for the sale of that fuel.

NG as a motor fuel is used almost exclusively by commercial vehicles, most of which view diesel as the conventional alternative. Using the same logic as was used for the development of the GGE unit, the convenience of the retail customer comparing the cost and fuel economy of a natural gas vehicle to a comparable conventional vehicle, it makes sense for NCWM to now “officially” define the DGE.

Other than §3.12. Liquefied Natural Gas, in the Engine Fuels and Automotive Lubricants Regulation section of Handbook 130, we find no specific provisions in either Handbook 44 or Handbook 130 for the retail sale of LNG as a motor fuel. However, LNG is sold in California and other states on a mass basis (by the pound), which allows for easy confirmation by weights and measures authorities. An “official” definition of the DGE as a specific mass of LNG and CNG would allow states to easily move from retail sale by pound to retail sale by DGE, simplifying the sale process for the retail customer used to dealing with “gallons of diesel” as a fuel measure.

Therefore, at this time we are asking for a definition of the Diesel Gallon Equivalent (and Diesel Liter Equivalent) units by NCWM.

*Justification of the Definition of a DGE as 6.38 Pounds of Compressed Natural Gas*

Handbook 130 contains the following definitions of natural Gas as a vehicle fuel\*:

**Gasoline liter equivalent (GLE).** – Gasoline liter equivalent (GLE) means

---

\* NIST handbook 130, 2006, Method of State Regulation, §§2.27.1.2 and 2.227.1.3; also Engine Fuels, Petroleum Products, and Automotive Lubricants Regulation, §§1.25 and 1.26.



0.678 kg of natural gas.

**Gasoline gallon equivalent (GGE).** – Gasoline gallon equivalent (GGE) means

2.567 kg (5.660 lb) of natural gas.

As the NCWM working group recognized during its deliberations in 1993 on the Gasoline Gallon Equivalent unit, both gasoline and natural gas can vary in their BTU content from sample to sample. The working group determined the gasoline gallon (energy) equivalent based on a gallon of Indolene (114,118 BTU/gal – lower heating value) and a survey of 6,811 natural gas samples nationwide with an average of 923.7 BTU/scf (lower heating value) and a density of 0.0458172 lb/cubic foot. This equates to 20,160.551 BTU/lb. Dividing gasoline's 114,118 BTU/gal by natural gas's 20,160.551 BTU/lb gives 5.660 lb of natural gas = 1 GGE. Similar calculations determined that a gasoline liter equivalent of natural gas equals 0.678 kg of natural gas.

Starting with 5.660 lb of natural gas = 1 GGE and 0.678 kg of natural gas = 1 GLE, we can calculate the mass of natural gas necessary to make a DGE and a DLE by comparing the amount of energy in a gallon of diesel fuel to the amount of energy in a gallon of gasoline fuel and apply that ratio to scale up the masses of natural gas calculated for the GGE and GLE units.

Unfortunately, it is no easier today than it was in 1993 to set one energy value as representative of a unit for all gasoline, (or diesel) fuel. EPA's certification fuel has likely changed in energy content since 1993, as both gasoline and diesel fuels have been modified for improved emissions.

We recommend using the most recent Department of Energy *Transportation Energy Data Book*<sup>\*</sup>, as an authoritative reference for both gasoline and diesel fuel energy values. Taking further surveys or basing our calculations on today's EPA certification fuel only delays our action, substantially increases costs, and, in the end, provides a limited potential increase in accuracy based on one point in time. Table B.4 of the *Transportation Energy Data Book*, on the heat content of fuels lists the net energy of diesel as 128,700 BTU/Gal. The 31<sup>st</sup> Edition may be downloaded at the following site. <http://cta.ornl.gov/data/download31.shtml>

Therefore, a Diesel Gallon Equivalent of compressed natural gas is:

$$(128,700 \text{ BTU/Gal} / 20,160.551 \text{ BTU/lb}) = 6.38 \text{ lb/DGE} (2.894 \text{ kg/DGE})$$

and a Diesel Liter Equivalent of compressed natural gas is:

$$2.894 \text{ kg/DGE} \times 0.2642 \text{ Gal/Liter} = 0.765 \text{ kg/DLE}$$

---

<sup>\*</sup> Stacy C. Davis and Susan W. Diegel, Oak Ridge National Laboratory, *Transportation Energy Data Book*, Edition 31, 2012, ORNL-6987, or <http://cta.ornl.gov/data/index.shtml>

**Justification of the Definition of a DGE as 6.06 Pounds of Liquefied Natural Gas**

Cooling pipeline natural gas to -259 °F makes liquefied Natural Gas (LNG). The pipeline natural gas has the same national average composition as was determined for CNG with a LHV of 20,160.551 BTU/lb. In order to reduce the natural gas temperature for liquefaction carbon dioxide must be removed since it would solidify in the system and nitrogen, which remains a gas at LNG temperatures, is reduced to less than 0.5 % by volume in the final product. These changes to the composition of the pipeline gas increase the LHV of LNG to 21,240 BTU/lb.

National Average Natural Gas Composition Used for GGE Standard - Applied to LNG DGE - GGE Calculation							
CNG				LNG			
Components	LHV - BTU/LB	LBS/CF	%V <sup>1</sup>	%V <sup>2</sup>	LBS/CF	%MASS	LHV
C1	21537	0.0425	92.87	95.12	0.040425567	90.29305699	19446.41568
C2	20394	0.0803	3.34	3.42	0.002746969	6.13552872	1251.279727
C3	19807	0.1196	0.63	0.65	0.000771727	1.723700114	341.4132816
i-C4	19529	0.1582	0.07	0.07	0.000113422	0.253334595	49.47371306
n-C4	19815	0.1582	0.12	0.12	0.000194437	0.434287877	86.05414286
i-C5	19478	0.1907	0.04	0.04	7.81272E-05	0.174502103	33.98951966
n-C5	20485	0.1907	0.03	0.03	5.85954E-05	0.130876577	26.81006688
C6	19403	0.0228	0.05	0.05	1.16761E-05	0.026079234	5.06015379
N2	0	0.0744	2.07	0.50	0.000370992	0.828633789	0
CO2	0	0.117	0.78	0.00	0	0	0
			100.00	100.00	0.044771512	100	21240
						Diesel <sup>3</sup> LHV=	128,700
						LNG - DGE=	6.06

<sup>1</sup>CNG national average composition of natural gas from the NCWM Laws and Regulations - CNG Working Group letter 10/18/1993 Appendix A. Conversion Factor Background

<sup>2</sup>LNG composition based on CNG composition with CO2 removed and nitrogen reduced to 0.5%

<sup>3</sup> DOE Transportation Energy Data Book Table B.4

Note: each 0.1% reduction/addition of nitrogen in LNG lowers/raises DGE by 0.01 lb

Therefore, a Diesel Gallon Equivalent of LNG is:

$$128,700 \text{ BTU/lb} / 21,240 \text{ BTU/lb} = 6.06 \text{ lb/DGE} (2.749 \text{ kg/DGE})$$

and a Diesel Liter Equivalent of LNG is:

$$2.749 \text{ kg/DGE} \times 0.2642 \text{ Gal/Liter} = 0.7263 \text{ kg/DLE}$$

The attached presentation file provides an overview of the CNG and LNG processes from pipeline to dispensing along with the calculation of the LNG LHV based on the change in LNG chemical composition through the liquefaction process.

Prepared by:

Clean Vehicle Education Foundation

<http://www.cleanvehicle.org>

THIS PAGE INTENTIONALLY LEFT BLANK

## Appendix B

### Item 260-1: Handbook 133

#### Section 2.7. Chitterling Test Procedure

### How to Determine the Net Weight and Purge of Packaged Chitterlings<sup>1</sup> Using NIST Handbook 133, “Checking the Net Contents of Packaged Goods”

#### Executive Summary

When a Weights and Measures Inspector tests frozen chitterlings, the purpose of the inspection is to determine if the package contains the labeled net weight and if the purge is 20 % or less after thawing (purge is based on the labeled net weight). Inspectors typically use Section 2.3. “Basic Test Procedure” and other portions of National Institute of Standards and Technology (NIST) Handbook 133, “Checking the Net Contents of Packaged Goods” (the 2005 edition was adopted by USDA in 73 Federal Register 52192 on Sept. 9, 2008) to conduct these tests. To determine the amount of purge, inspectors modify the procedures in Section 2.6. “Determining the Net Weight of Encased-In-Ice and Ice Glazed Products.” The modifications include thawing the product while it is still in the package, then draining it and applying the 20 % purge limit established by the Food Safety and Inspection Service (FSIS) of the U.S. Department of Agriculture (USDA). Inspectors defer to the USDA purge value because a specific limiting value for the purge for chitterlings has not been adopted by the National Conference on Weights and Measures (NCWM), and, therefore, a value is not in NIST Handbook 133. The USDA recommends that purge determinations be conducted at the packing plant. However, state and local inspections of chitterlings are needed outside packing plants because inspections are usually only carried out in response to consumer complaints about short weight or excessive purge in the packages they purchase at retail or over the Internet. In the past few years, most of the inspection results shared with the Office of Weights and Measures (OWM) at NIST indicated that inspectors have found the purge from chitterlings was often much greater than 20 %. In 2011, several states contacted the OWM seeking technical assistance because of ongoing disputes they were having with packers over the test procedures used and the amount of purge allowed. Some states reported that they found purge amounts as high as 50 % in packages put-up by both domestic and foreign packers. In addition to the test data from inspectors and multiple packers, a study conducted at Iowa State University on the purge from frozen chitterlings revealed purge ranging from 30 % to 50 %. OWM reviewed the test methods used by the states, Iowa State University, and several chitterling packers to identify opportunities for improving the accuracy and repeatability of the test procedure. A few differences between the test procedures used by packers and state inspectors were found, but, overall, the approaches to testing were consistent. As noted above, the NIST Handbook 133 does not include a test procedure or purge allowance for chitterlings. Because state weights and measures officials are required to investigate the complaints they receive,

and there is a general need for a nationally uniform test procedure for use in law enforcement, there appears to be sufficient justification for the NCWM to add a specific test procedure and purge limits for this unique product<sup>1</sup> to NIST Handbook 133. The OWM has developed a draft test procedure for review and evaluation by packers and officials that may, depending on the level of support it finds among officials and packers, be submitted to the NCWM for possible addition to NIST Handbook 133 later in 2014. Adoption and use of a uniform test procedure should improve test uniformity, increase confidence in the test results and protect consumers and packagers from unfair trade practices.

### **Other Issues That Can Be Studied if a Uniform Test Method Is Adopted**

Further study and guidance is needed regarding the methods used to thaw frozen chitterlings. Several weights and measures inspectors reported that thawing large packages of chitterlings takes an extensive amount of time and is labor and resource intensive (e.g., large quantities of warm water are used or several days are required for the product to thaw so it can be tested). If quicker thawing techniques could be identified, it could improve productivity and reduce inspection costs for packers and officials. Another effort that should benefit packers would be to identify and share good packing and filling practices to reduce variations in the packing process. The purge values on different lots tested by the states and in the university study varied significantly and large variations between packers were found. Reducing variability will benefit packers and consumers alike and may be achieved with only minor changes in the filling process. Perhaps the most significant issue that needs further study is if the 20 % limit is appropriate for frozen chitterlings. Several packers reported that they can only meet the 20 % purge limit and avoid consumer complaints on frozen chitterlings if they target their purge results to fall within 5 % to 10 %. Yet, chitterlings from these packers still do not meet the 20 % limit when their frozen chitterlings are thawed and tested using NIST Handbook 133 procedures.

The NIST Office of Weights and Measures invites interested weights and measures officials and packers to join a WG that will coordinate a review of the draft chitterling test procedure and other issues related to the testing of chitterlings (and beef tripe). If you are interested in participating in this work or if you have comments or questions, please contact Ken Butcher at (301) 975-4859 or [kbutcher@nist.gov](mailto:kbutcher@nist.gov)

---

<sup>1</sup> Because they are similar and have the same issues with freezing and thawing this procedure may be used for testing beef tripe (which is made from the stomach of cows).

## What are Chitterlings?

The USDA's definition of chitterlings is in 9 CFR Ch. III §317.8 (30). The term "Chitterlings" shall apply to the large intestines of swine, or young bovine animals when preceded with the word "Calf" or "Veal." Meat food products that contain chitterlings or calf or veal chitterlings, in accordance with § 318.6(b)(8) of this subchapter shall be identified with product names that refer to such ingredients, as for instance, "Chitterling Loaf," "Chitterling Pie," or "Calf Chitterlings and Gravy." Their texture is similar to calamari (squid). According to the USDA,<sup>2</sup> chitterlings are a popular food served in many parts of the United States, the Caribbean, Latin America, western Asia, and Europe. Also called "chitlins," as defined above, they are the large intestines of swine (hogs) or calves. According to one industry source, chitterlings are eaten year round but about 90 % are sold during the Thanksgiving, Christmas, and New Year Holidays. Chitterlings are also used as casings for some sausages.

## Chitterling Cleaning, Processing and Packaging

The large intestine of a hog is a soft tubular organ typically 5 meters to 6 meters (16 ft to 20 ft) long. When the intestine is removed from a freshly killed hog, it usually contains undigested food, fecal matter, and fat with glands and connective tissue still attached. To avoid foodborne illnesses, intestines require a thorough cleaning prior to consumption. Chitterlings can become contaminated with the bacteria *Yersinia enterocolitica*, which can cause a diarrheal illness called "yersiniosis." *Yersinia* survives in cold temperatures and can grow inside the refrigerator. Other foodborne pathogens (e.g., salmonella and *E. coli*) may also be present. For these reasons, the FSIS regulations require the product be thoroughly cleaned by the packer to prevent disease.

At most packing plants, the cleaning is performed using machines that flush fecal matter from pig intestines using tap water. The chitterlings are uncoiled and manually placed over a feed tube which sprays water through the tube forcing the fecal material out. During the process, the intestines are cut and cleaned again in centrifugal or agitating washing bowls prior to undergoing final inspection and cleaning before being packaged. Although the cleaning equipment is designed to minimize structural damage to the cells of the intestines, the pressurized water may wash away some of the mucosa (intestinal lining) along with the digested material and fecal matter. The damage to the mucosa may increase the amount of purge released from the chitterlings. Packers tell consumers that even chitterlings sold as "pre-cleaned" should be rinsed and cleaned again before cooking.

---

<sup>2</sup> [http://www.fsis.usda.gov/wps/portal/fsis/topics/food-safety-education/get-answers/food-safety-fact-sheets/foodborne-illness-and-disease/yersiniosis-and-chitterlings/ct\\_index](http://www.fsis.usda.gov/wps/portal/fsis/topics/food-safety-education/get-answers/food-safety-fact-sheets/foodborne-illness-and-disease/yersiniosis-and-chitterlings/ct_index) Accessed July 11, 2014.

## Water Content<sup>3</sup> and Purge

Meat and poultry products have naturally occurring high water content. For example, a whole chicken fryer is 66 % water and a whole beef brisket is made up of about 71 % water. USDA studies show that raw chitterlings typically have water content of 67 % to 69 %.

### CURRENT USDA GUIDANCE:

#### Net Weight on Chitterlings<sup>4</sup>

Published 10/28/2009 09:29 AM | Updated 10/28/2009 09:29 AM

**QUESTION TO FSIS:** *“According to the Food Standards and Labeling Policy Book, frozen chitterlings are permitted to contain 20 % of the frozen net weight as purge. At what point in the process should the determination of the 20 % purge be measured; post packaging and prior to freezing, or post packaging after freezing?”*

**FSIS RESPONSE:** *“Historically, FSIS has not objected to chitterlings having up to a 20% purge due to the washing and preparation with water. Net weight should be verified after packaging and prior to freezing. When verifying net weights, inspection personnel will not take regulatory action for product containing up to 20% purge. This maximum of 20% purge is representative of actual purge from the washing process; it is not acceptable to add additional liquid to the package.”*

The basis of the FSIS allowance for purge may represent the purge found with fresh-raw chitterlings and may NOT be based on data from actual purge testing on frozen chitterlings. The 20 % purge value appears to have been taken from the 1981 Edition of USDA Agriculture Handbook No. 8-10 prepared by the USDA Human Nutrition Information Service<sup>5</sup> based on unfrozen chitterlings. As explained earlier several packers reported that they can only meet the 20 % purge limit and avoid consumer complaints on frozen chitterlings if they target their purge results to fall between 5 % to 10 %.

---

<sup>3</sup> “Yield and Comparison of Nutritive and Energy Values; Fatty Acids and Cholesterol Content of Raw and Cooked Chitterlings.” By M.W. Vaughn, D.P. Wallace and B.W. Forster in Journal of Food Science – Volume 43 (1978).

<sup>4</sup> [http://askfsis.custhelp.com/app/answers/detail/a\\_id/1309](http://askfsis.custhelp.com/app/answers/detail/a_id/1309) - Accessed on July 10, 2014.

<sup>5</sup> See Page 126 -- Pork, Fresh Chitterlings, Raw - Composition of Foods: pork products: raw, processed, prepared / Part 2 of 2 of Agriculture Handbook 1983. Volume 008-10 Pages p. 101-206. Author: Anderson, Barbara A Doc ID ah008\_10pt2 U.S. Dept. of Agriculture, Human Nutrition Information Service Subject: Pork--Composition--Tables; Canned pork--Composition--Tables; Food Composition Tables (<http://naldc.nal.usda.gov/catalog/CAT84802715> ).

See also <http://naldc.nal.usda.gov/naldc/download.xhtml?id=CAT84802715&content=PDF> which was accessed on July 10, 2014.

## Does USDA consider Purge to be retained water?

No, FSIS Directive 6700.1 (11/27/2002) addresses this question:

*17. How is the retained water statement handled with chitterlings since the product is allowed to be packaged with up to a 20 percent purge?*

*Answer: Many years ago, before 1992, FSIS allowed, under normal conditions and good manufacturing practices, purge in containers of chitterlings not to exceed 20 percent of the marked weight of the product. The policy is long-held and is practiced industry wide. Consumers who purchase this product are aware of the policy and practice and have come to expect moisture content in chitterlings. As a result of this long-standing policy, no retained water statement is required when chitterlings are packaged with a purge. If chitterlings retain water during post evisceration processing and are not packaged with a purge, the product's labeling is required to bear a retained water statement.*

### The Impact of Freezing on Cells – Industry Approaches to Compliance

When meat or poultry products are frozen, the water that is a natural component of all meats turns to solid ice crystals. The water expands when it freezes and the sharp-edged crystals push into the surrounding tissue, rupturing the cells. The water that is outside the cell wall freezes first. As it does, it leeches water from the cell walls. After thawing, the product will have lost some of its natural springiness because the water released from the cells during freezing flows out of the thawing meats. Studies have shown that under some conditions, cell destruction can also occur during the thawing process.<sup>6</sup> After chitterlings are washed, they are weighed in advance of packaging. The weight includes the chitterlings (and the fluid held within the cell walls), and water accumulated in the folds and on the surface of the chitterlings, which are then packaged for freezing. Chitterlings are made up of gelatinous cells that easily rupture and the amount of damage depends primarily on the speed of the freezing process. When the chitterlings are thawed, the purge flowing out includes water that was originally held within many of the cells, the surface water, and water trapped in the crevices and folds of the product.

There are studies showing freezing damages the cells and releases water that cannot be reabsorbed. If chitterlings are tested before freezing and a purge of 20 % is found, any test conducted after freezing and thawing will find a much higher level of purge. Purge occurs with all meats, but with chitterlings, the amount of purge is measured and is required to meet a limit. The USDA limits the amount of water at point of pack to 20 % so consumers receive a certain amount of meat solids in a product that is packaged in water. A limit on purge is similar to a standard-of-fill that the Food and Drug Administration defines for other food products with similar water versus solid content issues (e.g., tuna fish). For these reasons, and to ensure they meet the USDA requirements, several chitterling packers keep their pre-packaged chitterling purge levels to 7 % to 10 %. Yet, as mentioned above, packages from those packers are often found to have purge levels of 24 % to 34 % when thawed, and the NIST Handbook 133 procedures are used to test purge levels.

---

<sup>6</sup> Mazur, Peter, "Freezing of Living Cells: mechanisms and implications." American Journal of Physiology, 247. 1984.



## Background

In 2011 the OWM was contacted by several state weights and measures officials for assistance in resolving disagreements with packers over the use of NIST Handbook 133, “Checking the Net Contents of Packaged Goods.” Several state inspectors reported they routinely receive consumer complaints about the amount of purge in chitterlings, and they had used Section 2.6. “Determining the Net Weight of Encased-in-Ice and Ice Glazed Products” to verify the net weight. They also reported that the amount of purge had been determined after thawing the frozen chitterlings. Data from the inspectors revealed that the purge from all of the chitterlings tested exceeded a 20 % limit specified by USDA. OWM also learned that at least one state had taken legal action against a packer whose chitterlings failed the 20 % purge limit. The state had collected its evidence using a test procedure similar to Section 2.6. but had added some practical modifications so it was usable in testing chitterlings.<sup>7</sup>

Another concern raised by the inspectors was that neither a purge limit nor test procedures for the determination of purge are included in NIST Handbook 133. As noted above, the test procedures in Section 2.6. were originally developed for drained weight testing of shrimp and other frozen foods to verify only net weight declarations. OWM agreed to review the test methods used by the state inspectors to see if the current test procedure could be revised to make it appropriate for use in testing chitterlings.

**Note:** The 2005 edition of NIST Handbook 133 was adopted by the Food Safety and Inspection Service (FSIS) of the U.S. Department of Agriculture for use in testing meat and poultry products in 2008 (see 9 CFR 442.2 “Quantity of Contents Labeling and Procedures and Requirements for Accurate Weights” and 73 FR 52192).

Based on the information presented above, state weights and measures inspectors need to have a test procedure tailored to the testing of chitterlings in NIST Handbook 133 so inspectors can test in retail stores in response to consumer complaints. States do not have access to packing plants located in other states or countries; therefore, they rely on tests at retail or wholesale locations for their investigations. Testing at the retail level (the end point in distribution) allows inspectors to look at a variety of packers to ensure fair competition, and state inspectors are able to discover changes to the product that may occur during distribution from environmental factors, mishandling or tampering of product. Packers and consumers both benefit from having retail marketplace surveillance to maintain equity and fair competition.

---

<sup>7</sup> In November 2010, San Diego County District Attorney’s Office filed a complaint and stipulated judgment against Clougherty Packing, LLC for \$451,564. Clougherty settled without admitting fault or liability. The case resulted from a consumer complaint to the California Department of Measurement Standards (CDMS) regarding large amounts of purge from chitterlings. More than 60 000 packages of chitterlings were ordered off-sale after samples were tested and shortages ranging from 31 % to 45 % were found.

## Net Weight versus Purge

A review of test results from several states and a university indicates that a majority of the packaged chitterlings tested comply with the average and individual package requirements for net weight as required under NIST Handbook 133. Currently, the handbook does not include limits on the amount of purge from chitterlings. State weights and measures officials follow a 20 % limit published by the USDA. Determining the amount of purge goes beyond net weight testing. Several inspectors reported the test procedure to conduct the purge tests in Section 2.6. had to be modified. Inspectors asked for technical assistance in evaluating whether their modifications to the current procedure were acceptable and requested revisions to accommodate purge testing be made to NIST Handbook 133 so the test procedure would be uniform and accepted nationally.

USDA established the limits on purge to ensure that packages of chitterlings contain a certain percentage of meat. Currently, the USDA policy sets the upper limit of purge at 20 % of the labeled quantity. Recent inspections conducted by several states and a comprehensive study by a university found that packages of frozen chitterlings from several packers (including one supplier from Europe) contain purge in the range of  $\pm 30\%$  to  $+ 50\%$ . The following results were obtained using the current test procedures based on Section 2.6. Inspections by state weights and measures inspectors in California, Florida, Mississippi and Louisiana, which were carried out in response to consumer complaints about high amounts of purge in packages of chitterlings, revealed the following: (1) In October 2010, weights and measures inspectors from Louisiana tested samples from 10 lots (totaling more than 7740 containers) and found an average purge of 49 %; (2) In October 2010, Florida weights and measures inspectors tested samples from a lot of 324 packages and found an average purge 33 %; and (3) In November 2010, the San Diego District Attorney announced a settlement in an investigation of a consumer complaint. In this case weights and measures inspectors had tested lots totaling 60,588 packages from one packer and had found shortages of 31 % to 45 %.

Several chitterling packers have expressed concerns about the appropriateness of the test procedures used by inspectors and about the high purge levels inspections had uncovered. One packer/retailer commented that it was difficult for his company to compete against many other packers because chitterlings are not routinely tested for compliance with purge limits. Several packers shared in-plant test data from their plants showing they target for a purge of 7 % to 10 % on in-plant tests. These packers reported that if they do not target for low purge levels in their testing, they see a dramatic jump in consumer complaints about excessive purge.

The data from one university study of five packers indicates that the purge from sample lots (total  $5 \times 30 = 150$  packages) ranged from 26.9 % to 57.3 % or from about 7 % to 37 % higher than the 20 % limit set by the USDA. The data was obtained in laboratory conditions and showed significant differences in purge amounts. The differences are likely caused by packers having different pre and post freezing purge targets and variations in test equipment and drain procedures. There are also likely to be different fill target weights, weighing devices (e.g., different scale divisions), and other unique packaging procedures or freezing processes.

Variations in the standard deviations found on packages produced by the different packers ranged from 1.7 % to 5.2 %. The results include samples with purge rates as low as 18 % and as high as 66 %. The range of net contents is so wide that it would likely frustrate the ability of consumers

to estimate how many packages to purchase to obtain a specific amount of chitterlings for use in a recipe, to determine serving size, and to make value comparisons. Even packages from the same packer had a wide range of purge values.

Packer	a	b	c	d	e
Average Purge*	34.2 %	57.3 %	26.9 %	33.6 %	27.9 %
Standard Deviation ( $\sigma$ )	1.9	3.2	1.7	5.2	2.4
Range of Results ( $\pm 3 \sigma$ )	28 % to 40 %	47 % to 66 %	21 % to 31 %	18 % to 49 %	20 % to 35 %

\*Data is percentage purge based on labeled quantity from a 2008 study conducted by Dr. Ken Prusa, Professor, Iowa State University of Science and Technology on samples from five packers of 30 packages of frozen chitterlings using the procedures in Section 2.6. of NIST Handbook 133. Published with permission.

### Thawing Procedures

Several inspectors requested guidance on how to efficiently thaw chitterlings to improve the proficiency of their tests and accuracy of the results. Inspectors stated the thawing process for large frozen packages (e.g., 2.2 kg, 5.0 kg [5 lb and 10 lb] packages of frozen product) is time consuming regardless of the product. Access to large quantities of hot water and sink space are significant problems in many locations (the National Marine Fisheries, an agency of the U.S. Department of Commerce has indicated that their inspectors face similar challenges when they conduct inspections of imported seafood). A few state inspectors reported that they have to let sample packages of chitterlings sit in room temperature water for long hours or in a refrigerator for several days to allow them to thaw. Another packer reported that its tests had not revealed any correlation between thaw time and increased purge. Still, reviewing the current thawing procedures to identify ways to increase uniformity, repeatability, and accuracy may be beneficial.

The thawing procedure in NIST Handbook 133 specifies that the water temperature be maintained between 23 °C to 29 °C (75 °F to 85 °F). Some inspectors asked if the temperatures of the water increases purge or if the temperature of the chitterlings at the time they are drained impacts purge levels. One packer has conducted some preliminary testing to explore that question. The results of those tests indicated that the water temperature used to thaw the chitterlings probably does not increase purge results, however, the water must not be too hot because it may cause the proteins in the chitterlings to denature. The packer's tests indicated the temperature of the chitterlings at the time they are drained may increase purge values. The data showed that warm chitterlings (e.g., room temperature or about 70 °F) lost about 10 % more purge than chitterlings cooled to 40 °F before draining. Because the packer's data is limited more study is needed to better understand this aspect of purge testing.

## Draft Proposed Section 2.7. for a Chitterling (and Beef Tripe) Test Procedure

### Introduction

This test procedure was originally developed for the Food and Drug Administration (FDA) in the 1960s for its use in testing frozen blocks of seafood and other products. Over the years it has been modified for use in testing a variety of products including frozen seafood and glazed chicken breasts. Based on a review of the USDA procedures and information received from several weights and measures inspectors and chitterling packers, several changes are proposed for Section 2.6. “Determining the Net Weight of Encased-in-Ice and Ice Glazed Products” to make it appropriate for use in testing frozen chitterlings when determining their net weight and the amount of purge in the package.

The draft test procedure can be used in USDA inspected packing plants and in wholesale and retail locations by weights and measures officials to determine if it is practical and to identify additional areas for improvement. For the test procedure to be added to NIST Handbook 133, it must be adopted by the NCWM.<sup>8</sup> Before submitting any proposal to the NCWM, support from both packers and weights and measures officials must be garnered. One goal of this paper is to raise the question of whether or not the 20 % purge limit set by USDA is appropriate for previously frozen chitterlings. Based on the information presented below, the current purge value of 20 % may not be appropriate for use in testing frozen chitterlings. However, increasing it to 30 % would not dramatically increase compliance levels. Before an appropriate purge value for frozen chitterlings can be recommended, data from tests of packages from many packers must be collected using a uniform test procedure.

The OWM recommends the formation of a WG to review of the draft chitterling test procedure. The group should consider investigating some of the other issues mentioned above, including developing and sharing good packing practices and alternative thawing procedures. Once a uniform test method and good packing practices are in place, data could then be collected to determine if a different purge limit for frozen chitterlings should be considered. OWM will use the draft test procedure to provide training to interested state officials and will recommend that states use it in investigations of consumer complaints. OWM will also encourage states to share their experience with the draft procedure so it can be improved, and invite them to share test data with the group so the data can be used to evaluate the test procedure and existing purge limit.

---

<sup>8</sup> The NCWM is a not-for-profit corporation dedicated to developing the U.S. standards for weights and measures. The NCWM is open to all interested parties and among its membership are representatives of the American Meat Institute and Food Marketing Institute and many of their member companies.

## **Modifications of Section 2.6. Net Weight of Encased-In-Ice and Ice Glazed Products for Use with Chitterlings**

1. As with other foods where drained weight testing is used, the weight-per-volume of solids is approximately the same as the fluid poured from the package so all of the samples must be opened. For this reason, the use of an average tare weight or an average purge value cannot be used to compute package errors.

**Change:** Add the following note to the test procedure in NIST Handbook 133:

**Note:** All of the packages in the sample must be opened. This is because the purge from each package may vary significantly. Another reason is that the weight-per-volume of solids is often nearly equal to the weight of the liquid poured from the package. For these reasons an average tare weight or average purge value calculated using just a few packages would not be representative of the sample.

2. A Weights and Measures Inspector reported that a 300 mm (12 in) sieve could hold 2.2 kg (5 lb) of chitterlings when tilted at 30 degrees but several measurements were required when larger containers were tested. It was suggested that a note be added to the test procedure to clarify that multiple measurements were permitted and to alert inspectors that some sieves may not hold the entire contents of larger packages.

**Change:** Add the following:

**Note:** If the amount of chitterlings in the package exceeds the capacity of the sieve, divide the solids evenly among several sieves of the same dimensions or make multiple determinations using a single sieve.

### **Addressing Differences from Current Field Use**

3. **Packed or Unpacked** – Section 2.6. requires products to be unwrapped so they can be thawed in a water bath. The temperature is typically maintained using a constant flow of warm water. In discussions with state weights and measures inspectors who have tested chitterlings, we learned that they thaw the chitterlings while they are still packaged so they can obtain an accurate measurement of the purge from each package. State inspectors also report that allowing selected frozen sample packages to thaw for several days at 4 °C (40 °F) and then using a warm water bath to complete the process is a practical alternative that should be recognized when limited time and other resources exist (e.g., a sample size of 48 packages is needed to test a large inspection lot and there are limited sinks and water supplies at the point of inspection.)

**Change:** Revise the procedure so frozen chitterlings can be thawed in the package and add a statement indicating that alternative thawing procedures may be used. Also, delete reference to the wire mesh basket used to hold unwrapped products under water while preventing the loss of product solids.

Associated with this provision is a note which reads that “Direct immersion does not result in the product absorbing moisture because the freezing process causes tissue to lose its ability to hold water.” If the procedure is modified to allow frozen chitterlings to be thawed in the package the note is no longer relevant and it should be removed.

**Change:** Delete the NOTE.

4. **Thawing Procedure** – Inspectors have reported difficulties using the thawing techniques prescribed in Section 2.6. due to the size of the containers, sample sizes, availability of an adequate size water bath, and supply of hot water. The draft procedure calls for the packages to be immersed in a water bath. But, when the sample is made up of 4.0 kg (10 lb) buckets, many sinks cannot hold more than a few containers. To determine if the center of a bucket has thawed an inspector recommended that a dowel rod be inserted gently into the container to determine if there is any remaining frozen product or chunks of ice.

**Change:** Amend the section to allow for the use a sink, ice chest or other large vessel. Add a note for the inspector to use a dowel rod to determine if the product has completely thawed and that there are no chunks of ice in the container.

5. A packer suggested guidance to help inspectors decide when chitterlings are “thawed out.” The recommendation was to add a statement that a “thawed condition” is one in which no ice crystals are observed or felt in or on the chitterlings.

**Change:** Insert a note that the chitterlings are thawed when it is determined by touch that they are not rigid and no ice crystals are observed or felt within or on their outside surface.

6. **Drain Angle** – The techniques that inspectors use to tilt the sieve to drain chitterlings (and other frozen products) vary widely which may affect test results. The current procedure specifies that the sieve be tilted at a 30 degree angle for two minutes. To address this issue, a tilt-angle block was fabricated so that it raises a 304 mm (12 in) sieve to the correct height of 152 mm (6 in) to achieve a 30 degree angle. (See figure 1 on page 17 for an example). The angle block was designed for use with both the 203 mm (8 in) and 304 mm (12 in) sieves and at other drain angles. A drawing of one type of angle block is available upon request from OWM to allow for local construction.

**Change:** Add Figure 1 (page 17) to the test procedure and provide access to drawings of one type of tilt-angle block so it can be fabricated locally. Include the following note:

**Note:** Other methods may be used for draining as long as the correct drain angle is used.

7. **USDA Policy on Chitterling Purge** – Several inspectors pointed out that NIST Handbook 133 does not include a purge limit. It was suggested that the current USDA limit on purge be added to NIST Handbook 133.

**Change:** Add a requirement to NIST Handbook 133 to include the USDA 20 % limit on purge.

8. **USDA Policy on Chitterling Purge** – The USDA procedure for purge tests conducted inside a packing plant is to calculate it using the individual labeled quantity and actual net weight of

the package, not the gross weights of the individual packages (standardized). USDA policy also only applies an average requirement to purge tests. No Maximum Allowable Variation is applied to the individual purge results. This USDA policy must be added to the NIST Handbook 133 procedure to ensure consistent testing and application of the purge requirements between the packing plant and the field.

**Change:** Add a step in the procedure to calculate purge values for each package using the quantity labeled on the package.

10. **Other Changes** – Amend the procedure to explain how to determine purge values and net weight requirements. These additions are incorporated in the following draft of 2.X.

A draft procedure for determining the net weight and percent of purge of chitterlings is presented below. If the procedure is added to NIST Handbook 133, it will be added as a new Section 2.7. in Chapter 2. “Test Procedures – For Packages Labeled by Weight – Gravimetric Testing.” Worksheets for use in testing chitterlings with both the Category A and Category B Sampling Plans are included.

### **Draft NIST Handbook 133 – Chitterling Test Procedure 2.7.**

Because of the unique properties of chitterlings, they require special test methods to ensure the integrity and consistency of the test.

#### **2.7. Determining the Net Weight and Percent of Purge in Packages of Fresh and Frozen Chitterlings**

##### **2.7.1. Test Equipment**

- Scale or balance and mass standards (the standards are used to verify the accuracy and repeatability of the weighing device).
- Partial immersion thermometer or equivalent with 1 °C (2 °F) graduations and a – 35 °C to + 50 °C (– 30 °F to + 120 °F) accurate to ± 1 °C (± 2 °F).
- Sink (e.g., water bath, ice chest) or other receptacle of suitable size to hold the packages for thawing and water source and hose with fresh water that can be maintained at a temperature between 23 °C to 29 °C (75 °F to 85 °F) (for thawing plastic bags or buckets of chitterlings).

An alternative thawing procedure for packages requires access to a refrigerator that must be available for storing sample packages for several days to thaw.

- Stainless Steel Sieve(s) and Drain Pan(s) - Number 8 mesh, 203 mm (8 in) or 304 mm (12 in). Use is based on the labeled net weight of the package under inspection.
- Stopwatch (to measure drain periods).

- Knife or box cutter (to open packages).
- Waterproof marking pen (for numbering the packages).
- Disposable (non-latex) gloves.
- Paper towels (drying sieve drain pan, packages and work area).
- Large plastic bags (to hold product emptied from packages).
- Plastic rod (to insert into buckets of chitterlings to determine if the product is thawed and to ensure there are no chunks of ice remaining).

### **2.7.2. Test Procedure for Net Weight and Purge Determination for Fresh and Frozen Chitterlings.**

This procedure is used to determine (1) the net weight and (2) the purge in packages of fresh and frozen chitterlings. The purge determination procedure requires the destructive testing of all of the sample packages.

1. Follow Sections 2.3.1. Define the Inspection Lot, 2.3.2. Select Sampling Plans (use the “Category A” Sampling Plans in Table 2-1 if the testing is outside of a USDA inspected packing facility or, the “Category B” Sampling Plan in Table 2-2 if the testing is inside a USDA inspected packing facility), 2.3.3. Record Inspection Data, and 2.3.4. Random Sample Selection.
  - Select the random sample of packages.
  - Dry the sample packages and number each (e.g., 1-12) using a waterproof marker.
  - Record the Product Brand, Inspector Name, Labeled Net Weight (top of Column A), Packer Identity, Lot Code, Number of Unreasonable Errors, MAV from Table 2-9, and the Unit of Measure of the scale used for weight determinations on the worksheet. The appropriate information can be transferred to an official inspection report at the conclusion of the inspection. The worksheet should be added to the official record of the inspection.

#### **2.7.2.1. Net Weight and Purge Determinations**

Follow these procedures to determine the net weight and amount of purge from chitterlings.



### 2.7.2.1.1. Test Procedure for Determining the Net Weight and Purge from Fresh and Frozen Chitterlings.

1. Determine the Gross Weight of each sample package (record in Column B).
2. Determine the tare weight of the sieve drain pan (record in Drain Pan Tare above Column F).

#### Frozen Chitterlings

3. Fully immerse the unopened package of frozen chitterlings in a water bath maintained at a temperature between 23 °C to 29 °C (75 °F to 85 °F).

**Note:** An alternative approach to thawing large frozen packages (e.g., 5 kg [10 lb] plastic pails) is to randomly select [mark them to be held for inspection] the sample packages and place them in a refrigerator for partial thawing over several days and then carrying out the final thawing using the water bath technique.

**Note:** If the products are to be placed in refrigerated storage for several days for partial thawing, segregate them from other product inventory and mark each container with an identifier to allow the inspector to ensure that they were the samples selected for testing (mark both lid and container on buckets) when the inspection is resumed after the thawing process. Also, mark the packages with a conspicuous notice that they are being held for inspection.

4. Maintain a continuous flow of water into the bath to keep the temperature within the specified range until the chitterlings are thawed. The chitterlings are thawed when it is determined by touch that they are not rigid and no ice crystals are observed or felt within or on their outside surface.

Note: for buckets insert a plastic rod into the chitterlings to determine if the product is thawed and to ensure there are no chunks of ice remaining.

#### Fresh and Frozen Chitterlings

5. Draining the Chitterlings: depending on the availability of a sink and work space and the inspector's preference, use the procedures in either Method a. or Method b. to drain the chitterlings.<sup>9</sup> Refer to the Table for the appropriate size sieve to use based on the labeled net weight on the package.

---

<sup>9</sup> If carried out with proficiency, which comes with practical experience, the procedures in Method a. and Method b. will provide identical results. The procedure in Method b requires additional steps to calculate the Purged Net Weight but some inspectors have indicated that they prefer Method b. because the drain time and product is easier to control (because the chitterlings in the sieve may continue to drain). Regardless of the method used the inspector must handle the product carefully but quickly to avoid errors that may void the test. Also, some inspectors often use a waste container to collect the package liquids so that all of the product can be returned the package for subsequent return to the packer. Other inspectors

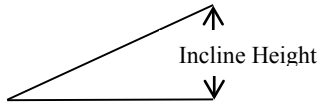
Table 1.			
Labeled Net Weight	Sieve Diameter	30 Degree Tilt from Horizontal	Incline Height
If more than 453 g (1 lb) use a:	300 mm (12 in)		175 mm (6.9 in)
If less than 453 g (1 lb) use a:	203 mm (8 in)		116.8 mm (4.6 in)
<ul style="list-style-type: none"> <li>This procedure requires that the sieve and drain pan be cleaned and dried after each use. It is a good measurement practice to obtain the dry weights of both the sieve and pan and recheck those weights periodically during the test to make sure the cleaning and drying procedures are efficient.</li> <li>If the amount of chitterlings in the package exceeds the capacity of the sieve, divide the solids evenly among two or more sieves of the same dimensions or make multiple determinations using a single sieve. Exercise care when transferring the chitterlings into the sieves to avoid spilling liquid which can void the test.</li> </ul>			

**Method A.** Place a sieve over a sink or waste collection container.<sup>10</sup> Pour the chitterlings into the sieve and distribute them over the surface of the sieve with a minimum of handling. Hold the sieve firmly and incline it 30 degrees (see Figure 1 for an example of a tilt block for use with a sink drain set at 30 degrees) to facilitate drainage, then start the stop watch and drain for exactly two-minutes. At the end of the drain time immediately transfer the chitterlings to a Drain Pan for weighing. Determine the Purged Net Weight of the chitterlings using the following formula and Record in Column F of the worksheet.

$$\text{Drained Chitterlings and Drain Pan} - \text{Drain Pan Tare} = \text{Purged Net Weight}$$

**Method B.** Place a sieve on its Drain Pan. Pour the chitterlings into the sieve and distribute them over the surface of the sieve with a minimum of handling. Hold the sieve firmly and incline it 30 degrees to facilitate drainage, then start the stop watch and drain for exactly two-minutes. At the end of the drain time immediately transfer the Drain Pan with the Purged Liquid to the scale for weighing. Dry the empty package to determine its tare weight and enter it in Column C. Determine the Purged Net Weight of the chitterlings using the following formula and Record in Column F of the worksheet.

$$(\text{Gross Weight of Package} - \text{Package Tare Weight}) - (\text{Weight of Purged Liquid \& Drain Pan} - \text{Drain Pan Tare}) = \text{Purged Net Weight}$$

$$(\text{Column B} - \text{Column C}) - (\text{Weight of Purged Liquid \& Drain Pan} - \text{Drain Pan Tare}) = \text{Purged Net Weight}$$

report that some retailers do not want the product repackaged so the liquids are drained into a sink, the solids discarded, and the disposition reported on the inspection report.

<sup>10</sup> Ibid., p. L&R – B14.

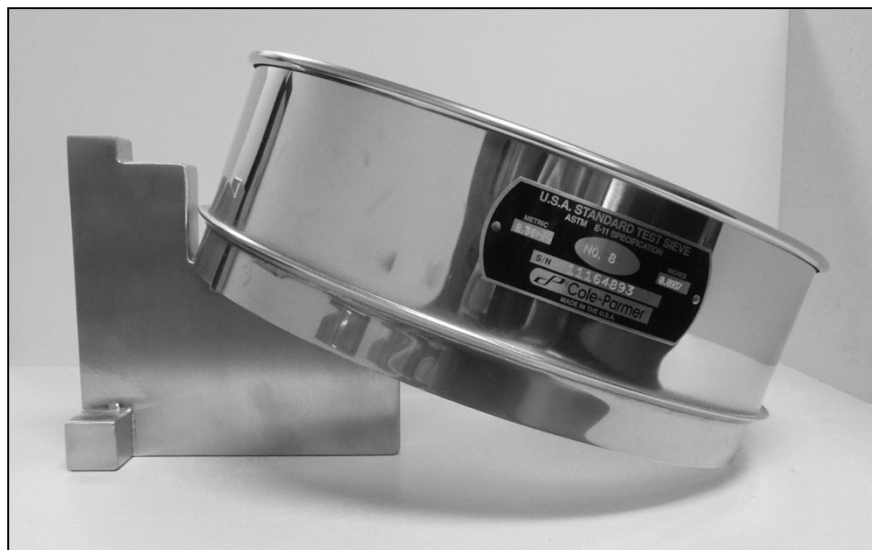

Figure 1. Tilt Block set at 30 degrees

6. Calculate Purge using the formula shown below (use the labeled net weight in Column A and NOT the gross weight of the package in Column B) and record the result in Column G of the Worksheet.

$$\text{Purge in \%} = (\text{Labeled Weight} - \text{Purged Net Weight}) \div \text{Labeled Weight} \times 100$$

$$\text{Purge in \%} = \text{Column A} - \text{Column F} \div \text{Column A} \times 100$$

Example: The labeled net weight is 5 lb and the Purged Net Weight is 4.19 lb

$$5 \text{ lb} - 4.19 \text{ lb} = 0.81 \text{ lb} \div 5 \text{ lb} = 0.162 \times 100 \% = 16.2 \% \text{ purge}$$

7. Dry the empty package and determine its tare weight (record in Column C of the worksheet.)
8. Subtract the individual Package Tare Weight from the individual Package Gross Weight to obtain the Actual Package Net Weight (record in Column D of worksheet). Do not use an Average Tare Weight. Use the formula:

$$\text{Actual Package Net Weight} = \text{Gross Weight} - \text{Tare Weight}$$

$$\text{Actual Package Net Weight} = \text{Column B} - \text{Column C}$$

9. Subtract the Actual Package Net Weight from the Labeled Net Weight (record in Column E of worksheet). Use the formula:

*Package Error = Labeled Net Weight – Actual Package Net Weight*

*Package Error = Column A – Column D*

Repeat for all packages in the sample.

**Note:** The determination of compliance with the net weight and purge requirements are carried out concurrently. The calculation of the average net weight and average purge is completed after all of the packages are opened and all purge amounts are obtained. The sample must pass both the net weight and purge tests to comply with this section.

### 2.7.3. Evaluations of Results – Compliance Determinations

#### 1. Net Weight

- a. **Individual Package Requirement:** If there are negative package errors, determine if any of the values exceed the Maximum Allowable Variation (MAV) for the packaged quantity in NIST Handbook 133, Appendix A, Table 2-9. “U.S. Department of Agriculture, Meat and Poultry Groups and Lower Limits for Individual Packages” (i.e., if the labeled net weight is more than 3 lb up to 10 lb then the MAV = 42.5 g (0.094 lb) 1.5 oz).
  - If a package error exceeds the MAV, mark it as “Failed” in the MAV Fail column.
  - Count the number of packages that exceed the MAV. If the number of packages that exceed the MAV is greater than the number allowed in NIST Handbook 133, Appendix A, Tables 2-1. Sampling Plans for Category A or Table 2-2. Sampling Plans for Category B, the sample fails. Mark the sample as “Failed” in the Net Weight Compliance section of the worksheet.
  - If the sample passes the Individual Package Requirement, apply the Average Error Requirement.
- b. **Average Error Requirement:** Sum the package errors in Column E and enter the value in E1 – Total Error. Divide the value in E1 by the Sample Size (n) to obtain an Average Error and enter the value in E2. If the Average Error (E2) is a positive number, the sample passes. Go to the Net Weight Compliance Section and mark the sample as “Passed.”
  - If the Average Error (E2) is a negative number, calculate the sample standard deviation of the package errors (Column E) and enter it in the block provided in the Net Weight Compliance section.

- Use the Sample Correction Factor (SCF) to calculate the Sample Error Limit (SEL).

$$\text{Sample Error Limit (SEL)} = \text{Sample Standard Deviation} \times \text{Sample Correction Factor}$$

- Disregarding the signs,
  - if the Average Error (E2) is larger than the SEL, the sample fails. Mark it “Failed” in the Net Weight Compliance Section of the worksheet,
  - or
  - if the Average Error is less than the SEL, the sample passes. Go to the Net Weight Compliance Section and mark the sample as “Passed.”

## 2. Purge

Follow these procedures to determine the amount of purge from the chitterlings. Apply the Average Requirement in Section 2.3.7.2. to the purge to determine if the sample passes or fails the requirement. The Average Adjusted Purge (AAP) for the sample shall not exceed 20 % of the labeled weight. The Maximum Allowable Variations (Lower Limits for Individual Packages) in NIST Handbook 133, Appendix A, Table 2-9. are not applied in the purge test.

- Sum the purge values in Column G and enter the value in G1 – Total Purge. Divide the value in G1 by the Sample Size (n) to obtain an Average Purge and enter the value in G2. If the Average Purge (G2) is less than or equal to 20 %, the sample passes. Go to the Purge Compliance Section and mark the sample as “Passed.”
- If the Average Purge is greater than 20 %, calculate the Sample Standard Deviation of the values in Column G and enter it in the block provided in the Purge Compliance section.
- Use the Sample Correction Factor (SCF) to calculate the Purge Sample Error Limit (PSEL) in percent.
- Subtract the PSEL from the Average Purge (G2) to obtain an Adjusted Average Purge (AAP) and enter that value in G3.
- Pass or Fail

- If the AAP (G3) is greater than 20 %, the sample fails. Enter the Purge Value (G3) in the Purge Compliance section and mark the sample as “Failed.”

or

- if the AAP (G3) is 20 % or less, the sample passes. Enter the Purge Value (G3) in the Purge Compliance section and mark the sample as “Passed.”

This publication is available free of charge from: <https://doi.org/10.6028/NIST.SP.1210>

INSPECTOR: <i>S. INSPECTOR</i>		<b>CHITTERLING WORKSHEET</b>								
DATE: <i>July 12, 2014</i>		<b>NET WEIGHT &amp; PURGE DETERMINATIONS</b>								
PACKER: <i>PACKER INC.</i> <i>1000 ROADWAY</i> <i>PACKINGTOWN, USA</i>		LOT CODE: <i>A342012</i>		DRAIN PAN TARE:		UNIT OF MEASURE:				
		BRAND: <i>ALLBRAND</i>		<i>0.997 lb</i>		<i>lb</i>				
PACKAGE NUMBER	A	B	C	D	E	IF ERROR EXCEEDS MAV = FAIL	F	G		
	LABELED NET WEIGHT	PACKAGE GROSS WEIGHT	PACKAGE TARE WEIGHT	ACTUAL PACKAGE NET WEIGHT  B – C =	PACKAGE ERROR  D – A =		PURGED NET WT WEIGHT OF DRAINED CHITTERLINGS (OR PURGED LIQUID) AND DRAIN PAN – DRAIN PAN TARE =	PURGE %  $\frac{(A - F) \times 100}{A}$		
1	<i>5 lb</i>	<i>5.130</i>	<i>0.032</i>	<i>5.098</i>	<i>0.098</i>		<i>4.19</i>	<i>16.2</i>	%	
2		<i>5.160</i>	<i>0.033</i>	<i>5.127</i>	<i>0.127</i>		<i>4.21</i>	<i>15.8</i>	%	
3		<i>5.012</i>	<i>0.032</i>	<i>4.980</i>	<i>- 0.020</i>		<i>4.17</i>	<i>16.6</i>	%	
4		<i>5.170</i>	<i>0.034</i>	<i>5.136</i>	<i>0.136</i>		<i>4.20</i>	<i>16.0</i>	%	
5		<i>5.020</i>	<i>0.033</i>	<i>4.987</i>	<i>- 0.013</i>		<i>4.18</i>	<i>16.4</i>	%	
6		<i>5.102</i>	<i>0.032</i>	<i>5.070</i>	<i>0.070</i>		<i>4.22</i>	<i>15.6</i>	%	
7		<i>5.051</i>	<i>0.033</i>	<i>5.018</i>	<i>0.018</i>		<i>4.24</i>	<i>15.2</i>	%	
8		<i>5.116</i>	<i>0.032</i>	<i>5.084</i>	<i>0.084</i>		<i>4.20</i>	<i>16.0</i>	%	
9		<i>5.120</i>	<i>0.034</i>	<i>5.086</i>	<i>0.086</i>		<i>4.19</i>	<i>16.2</i>	%	
10		<i>5.023</i>	<i>0.032</i>	<i>4.991</i>	<i>- 0.009</i>		<i>4.20</i>	<i>16.0</i>	%	
11		<i>5.122</i>	<i>0.032</i>	<i>5.090</i>	<i>0.090</i>		<i>4.26</i>	<i>14.8</i>	%	
12		<i>5.020</i>	<i>0.033</i>	<i>4.987</i>	<i>- 0.013</i>		<i>4.18</i>	<i>16.4</i>	%	
NUMBER OF UNREASONABLE ERRORS ALLOWED: NONE  Table 2-9. MAV: <i>0.0.094 lb</i>		E1 – TOTAL ERROR		<i>0.054 lb</i>		G1 – TOTAL PURGE		<i>191.2</i>		%
		E2 – AVERAGE ERROR (E1 ÷ n =)		<i>0.0045</i>		G2 – AVERAGE PURGE (G1 ÷ n =)		<i>15.9</i>		%
		G3 – ADJUSTED AVERAGE PURGE (G2 – PSEL =)								%
<p><b>NET WEIGHT COMPLIANCE:</b> (1) If any of the minus package errors (see Column E) exceed the MAV, the sample fails. (2) If none exceeds the MAV and the Average Error (E2) is a positive number, the sample passes. (3) If the Average Error (E2) is a minus number, calculate the sample standard deviation and enter it below. (4) Use the Sample Correction Factor (SCF) to calculate the Sample Error Limit (SEL). (5) Disregarding the signs, (a) if the Average Error (E2) is larger than the SEL, the sample fails or (b) if the Average Error is less than the SEL the sample passes.</p>										
<p><b>STANDARD DEVIATION:</b> <i>0.0601</i> × 0.635 (SCF) = <i>0.0382</i> (SEL)    <b>PASSED</b> √                      <b>FAILED</b></p>										
<p><b>PURGE COMPLIANCE:</b> MAVS ARE NOT APPLIED IN THE PURGE TEST (1) If the Average Purge Error (G2) is less than or equal to 20 %, the sample passes. (2) If the Average Purge Error is greater than 20 %, calculate the sample standard deviation and enter it below. (3) Use the Sample Correction Factor (SCF) to calculate the Purge Sample Error Limit (PSEL) in percent. (4) Subtract the PSEL from the Average Purge (G2) to obtain an Adjusted Average Purge (AAP) and enter that value in G3. (5)(a) If the AAP (G3) is greater than 20 %, the sample fails or (b) if the AAP (G3) is 20 % or less, the sample passes.</p>										
<p><b>STANDARD DEVIATION:</b> <i>2.420</i> × 0.635 (SCF) = <i>1.536</i> (PSEL)    <b>PURGE (G3)</b> <i>18.83</i> %                      <b>PASSED</b> √                      <b>FAILED</b></p>										
<p>SAMPLE DISPOSITION: <i>Lot passes on both criteria.</i></p>										

INSPECTOR: <i>S. INSPECTOR</i>		<b>CHITTERLING WORKSHEET FOR USE INSIDE A USDA INSPECTED PACKING PLANT</b>							
DATE: <i>July 14, 2014</i>		<b>NET WEIGHT &amp; PURGE DETERMINATIONS</b>							
		<b>WORKSHEET FOR SAMPLE OF 10 PACKAGES – HB 133 CATEGORY B</b>							
PACKER: <i>PACKER INC.</i> <i>1000 ROADWAY</i> <i>PACKINGTOWN, USA</i>				LOT CODE: <i>A34526</i>		DRAIN PAN TARE:		UNIT OF MEASURE:	
				BRAND: <i>ALLBRAND</i>		<i>0.997 lb</i>		<i>lb</i>	
PACKAGE NUMBER	A	B	C	D	E	IF ERROR EXCEEDS MAV = FAIL	F	G	
	Labeled Net Weight	Package Gross Weight	Package Tare Weight	Actual Package Net Weight  B – C =	Package Error  D – A =		Purged Net Wt Drained Chitterlings (or Purged Liquid) and Pan – Drain Pan Tare =	Purge %  $\frac{(A - F) \times 100}{A}$	
1	5	5.130	0.032	5.098	0.098		4.19	16.2	%
2		5.160	0.033	5.127	0.127		4.21	15.8	%
3		5.012	0.032	4.980	– 0.020		4.17	16.6	%
4		5.170	0.034	5.136	0.136		4.20	16.0	%
5		5.020	0.033	4.987	– 0.013		4.18	16.4	%
6		5.102	0.032	5.070	0.070		4.22	15.6	%
7		5.051	0.033	5.018	0.018		4.24	15.2	%
8		5.116	0.032	5.084	0.084		4.20	16.0	%
9		5.120	0.034	5.086	0.086		4.19	16.2	%
10		5.023	0.032	4.991	– 0.009		4.20	16.0	%
NUMBER OF UNREASONABLE ERRORS ALLOWED: NONE			<b>E1 – TOTAL ERROR</b> <i>0.057 lb</i>			<b>G1 – TOTAL PURGE</b> <i>160</i>			%
Table 2-9. MAV: 0.094 lb			<b>E2 – AVERAGE ERROR</b> <i>0.057 lb</i> (E1 ÷ n =)			<b>G2 – AVERAGE PURGE:</b> <i>16</i> (G1 ÷ n =)			%
<p><b>NET WEIGHT COMPLIANCE:</b> (1) If any of the minus package errors (see Column E) exceed the MAV the sample fails. (2) If none of the package errors exceeds the MAV and the Average Error (E2) is a positive number the sample passes. (3) If the Average Error (E2) is a minus number the sample fails.</p> <p><b>PASSED:</b> <input checked="" type="checkbox"/> <b>FAILED:</b> <input type="checkbox"/></p> <p><b>PURGE COMPLIANCE:</b> MAVS ARE NOT APPLIED IN THE PURGE TEST (1) If the Average Purge Error (G2) is less than or equal to 20 %, the sample passes. (2) If the Average Purge Error (G2) is greater than 20 %, the sample fails.</p> <p><b>PURGE:</b> <i>16 %</i> <b>PASSED:</b> <input checked="" type="checkbox"/> <b>FAILED:</b> <input type="checkbox"/></p> <p><b>SAMPLE DISPOSITION:</b> <i>Approved for sale.</i></p>									



**BLANK FORMS FOR CATEGORY A AND CATEGORY B SAMPLING  
PLANS ARE PROVIDED ON THE FOLLOWING PAGES**

INSPECTOR:		<b>CHITTERLING WORKSHEET</b>							
DATE:		<b>NET WEIGHT &amp; PURGE DETERMINATIONS</b>							
PACKER:		LOT CODE:				DRAIN PAN TARE:		UNIT OF MEASURE:	
		BRAND:							
PACKAGE NUMBER	A	B	C	D	E	IF ERROR EXCEEDS MAV = FAIL	F	G	
	LABELED NET WEIGHT	PACKAGE GROSS WEIGHT	PACKAGE TARE WEIGHT	ACTUAL PACKAGE NET WEIGHT  B - C =	PACKAGE ERROR  D - A =		PURGED NET WT  WEIGHT OF DRAINED CHITTERLINGS (OR PURGED LIQUID) AND DRAIN PAN - DRAIN PAN TARE =	PURGE %  $\frac{(A - F) \times 100}{A}$	
1									%
2									%
3									%
4									%
5									%
6									%
7									%
8									%
9									%
10									%
11									%
12									%
<b>NUMBER OF UNREASONABLE ERRORS ALLOWED:</b>			<b>E1 - TOTAL ERROR</b>			<b>G1 - TOTAL PURGE</b>			%
<b>Table 2-9. MAV:</b>			<b>E2 - AVERAGE ERROR (E1 ÷ n =)</b>			<b>G2 - AVERAGE PURGE (G1 ÷ n =)</b>			%
			<b>G3 - ADJUSTED AVERAGE PURGE (G2 - PSEL =)</b>						%
<p><b>NET WEIGHT COMPLIANCE:</b> (1) If any of the minus package errors (see Column E) exceed the MAV, the sample fails. (2) If none exceeds the MAV and the Average Error (E2) is a positive number, the sample passes. (3) If the Average Error (E2) is a minus number, calculate the sample standard deviation and enter it below. (4) Use the Sample Correction Factor (SCF) to calculate the Sample Error Limit (SEL). (5) Disregarding the signs, (a) if the Average Error (E2) is larger than the SEL, the sample fails or (b) if the Average Error is less than the SEL the sample passes.</p>									
<b>STANDARD DEVIATION:</b>		$\times 0.635$ (SCF) =		(SEL)		PASSED		FAILED	
<p><b>PURGE COMPLIANCE:</b> MAVS ARE NOT APPLIED IN THE PURGE TEST (1) If the Average Purge Error (G2) is less than or equal to 20 %, the sample passes. (2) If the Average Purge Error is greater than 20 %, calculate the sample standard deviation and enter it below. (3) Use the Sample Correction Factor (SCF) to calculate the Purge Sample Error Limit (PSEL) in percent. (4) Subtract the PSEL from the Average Purge (G2) to obtain an Adjusted Average Purge (AAP) and enter that value in G3. (5)(a) If the AAP (G3) is greater than 20 %, the sample fails or (b) if the AAP (G3) is 20 % or less, the sample passes.</p>									
<b>STANDARD DEVIATION:</b>		$\times 0.635$ (SCF) =		(PSEL) PURGE (G3)		PASSED		FAILED	
<b>SAMPLE DISPOSITION:</b>									

<b>INSPECTOR:</b>		<b>CHITTERLING WORKSHEET FOR USE INSIDE A USDA INSPECTED PACKING PLANT</b> <b>NET WEIGHT &amp; PURGE DETERMINATIONS</b>  <b>WORKSHEET FOR SAMPLE OF 10 PACKAGES – HB 133 CATEGORY B</b>								
DATE:										
<b>PACKER:</b>				<b>LOT CODE:</b>		<b>DRAIN PAN TARE:</b>	<b>UNIT OF MEASURE:</b>			
				<b>BRAND:</b>						
PACKAGE NUMBER	A	B	C	D	E	IF ERROR EXCEEDS MAV = FAIL	F	G		
	LABELED NET WEIGHT	PACKAGE GROSS WEIGHT	PACKAGE TARE WEIGHT	ACTUAL PACKAGE NET WEIGHT  B – C =	PACKAGE ERROR  D – A =		PURGED NET WT DRAINED CHITTERLINGS (OR PURGED LIQUID) AND PAN – DRAIN PAN TARE =	PURGE %  $\frac{(A - F) \times 100}{A}$		
1									%	
2									%	
3									%	
4									%	
5									%	
6									%	
7									%	
8									%	
9									%	
10									%	
<b>NUMBER OF UNREASONABLE ERRORS ALLOWED: NONE</b>  <b>Table 2-9. MAV:</b>			<b>E1 – TOTAL ERROR</b>				<b>G1 – TOTAL PURGE</b>		%	
			<b>E2 – AVERAGE ERROR (E1 ÷ n =)</b>				<b>G2 – AVERAGE PURGE: (G1 ÷ n =)</b>		%	
<b>NET WEIGHT COMPLIANCE:</b> (1) If any of the minus package errors (see Column E) exceed the MAV the sample fails. (2) If none of the package errors exceeds the MAV and the Average Error (E2) is a positive number the sample passes. (3) If the Average Error (E2) is a minus number the sample fails. <b>PASSED:</b> <span style="margin-left: 150px;"><b>FAILED:</b></span>										
<b>PURGE COMPLIANCE:</b> MAVS ARE NOT APPLIED IN THE PURGE TEST (1) If the Average Purge Error (G2) is less than or equal to 20 %, the sample passes. (2) If the Average Purge Error (G2) is greater than 20 %, the sample fails. <b>PURGE:</b> <span style="margin-left: 100px;"><b>PASSED:</b></span> <span style="margin-left: 100px;"><b>FAILED:</b></span>										
<b>SAMPLE DISPOSITION:</b>										

## Appendix C

Items: 232-3, 260-2, and 260-3: Handbook 133

Executive Summary and Supporting Documentation Animal Bedding (Feb. 9, 2015)

### Testing Packages of Animal Bedding and Peat Moss

with

### Compressed/Expanded Volume Declarations

#### Executive Summary

Animal Bedding (Bedding), also called pet or stall bedding, litter or simply bedding, is generally sold by dry volume in compressed or uncompressed packages. Based on numerous failed inspections of packaged animal bedding, the Office of Weights and Measures (OWM) conducted a study in which compressed and uncompressed packages of animal bedding were measured using a variety of procedures and test equipment. The results from those tests indicate that the current procedures in the 2014 edition of NIST Handbook 133, “Checking the Net Contents of Packaged Goods,” the dimensional inspection procedure for testing compressed packages (e.g., peat moss); and the volumetric inspection procedure (e.g., mulch); are inadequate for use in testing animal bedding. Uncompressed volume measurements of animal bedding are dependent on a number of factors, including the size and shape of the measuring container, the method of filling the measuring container, and the means used to break up the bedding prior to measuring. Based on the findings of this study, a draft procedure was developed for testing the uncompressed volume of animal bedding. OWM also designed and constructed new test measures to be used with the procedure, and then brought these measures to several animal bedding packaging plants for on-site verification of the test methods. Preliminary findings indicate that the draft procedure provides more consistent measurement results. Further, the study shows that there is no correlation between compressed and uncompressed volumes of animal bedding, leading to the conclusion that the requirement for compressed volume statements on the package label is unnecessary. The following proposal includes recommended changes to the method of sale for Animal Bedding in NIST Handbook 130, “Uniform Laws and Regulations in the Areas of Legal Metrology and Engine Fuel Quality,” a revised test procedure for NIST Handbook 133 relating to the verification of the compressed volume of peat moss (which has been used with animal bedding), new test procedures for measuring the compressed and uncompressed volumes of animal bedding, suggested test equipment and a gravimetric auditing procedure that allows inspectors to avoid destroying all of the packages.

**The following amendments to the Method of Sale of Commodities Regulation in NIST Handbook 130 are proposed:**

1. For the reasons described in background Section 2(a) (page 27), the OWM recommends that the method of sale for animal bedding be amended to eliminate the requirement that packages bear a declaration of compressed volume. If this recommendation is adopted, the method of sale will require that packages of bedding only have a declaration of the expanded (uncompressed) volume that can be recovered by the consumer.

2. For the reasons described in background Section 2(b) (page 28) the OWM recommends that a new definition for animal bedding and a revised method of sale be adopted to replace the current wording in Section 2.23. Animal Bedding, in the Uniform Method of Sale of Commodities Regulation in NIST Handbook 130. The proposed definition for animal bedding and recommended revisions to the method of sale are presented in the following:

**2.23. Animal Bedding. – ~~Packaged animal bedding of all kinds, except for baled straw, shall be sold by volume, that is, by the cubic meter, liter, or milliliter and by the cubic yard, cubic foot, or cubic inch. If the commodity is packaged in a compressed state, the quantity declaration shall include both the quantity in the compressed state and the usable quantity that can be recovered. Compressed animal bedding packages shall not include pre-compression volume statements.~~**

**Example:**

**~~250 mL expands to 500 mL (500 in<sup>3</sup> expands to 1000 in<sup>3</sup>).~~**

**2.23.1. Definitions.**

- (a) **Animal Bedding – any material, except for baled straw, kept, offered or exposed for sale or sold for primary use as a medium for any companion or livestock animal to nest or eliminate waste.**
- (b) **Expanded Volume – the volume of the product that can be recovered from the package by the consumer after it is unwrapped and uncompressed.**

**2.23.2. Method of Sale.**

- (a) **Packaged animal bedding shall be advertised, labeled, offered and exposed for sale and sold on the basis of the Expanded Volume. If unit pricing is offered to retail consumers, it shall be in terms of the price per liter.**
- (b) **The quantity declaration shall include the terms “Expanded Volume” or wording of similar import that expresses the facts, and shall be in terms of the largest whole unit of the milliliter, liter, or cubic meter. A declaration may also include the quantity in terms of largest whole unit of cubic inches, cubic foot, or cubic yard only.**
- (c) **The display of pre-compression volume, compressed volume or supplementary dry measure units (e.g., dry quart, bushel) anywhere on the package is prohibited.**

**Examples: Expanded Volume 41 Liters (1.4 Cubic Feet)**

**Expanded Volume 1.4 Cubic Feet (41 Liters)**

**Expanded Volume 27.9 Liters (1700 Cubic Inches)**

**Expanded Volume 113 L (4 Cubic Feet)**

**Expanded Volume 8 Cubic Feet (226 L)**

**2.23.1.3. Exemption - Non-Consumer Packages of Animal Bedding Sold to Laboratory Animal Research Industry. – Packaged animal bedding consisting of granular corncobs and other**

dry (8 % or less moisture), pelleted, and/or non-compressible bedding materials that are sold to commercial (non-retail) end users in the laboratory animal research industry (government, medical, university, preclinical, pharmaceutical, research, biotech, and research institutions) may be sold on the basis of weight.

(Added 1990) (Amended 2012 **and 20XX**)

**The following test procedures and other amendments are proposed for Chapter 3. “Test Procedures for Packages Labeled by Volume” in NIST Handbook 133:**

1. For the reasons described in the background of Section 4 (page 46), the OWM recommends adoption of amendments to Section 3.9. “Peat Moss.” The proposed amendments revise the dimensional test procedure used in verifying compressed volume declarations on packages of peat moss and, if the requirement that packages bear a declaration of the compressed volume in the package is not eliminated as recommended above, animal bedding (see page 4).
2. For the reasons described in the background of Section 3 (page 30), the OWM recommends adoption of a new Section 3.15. that includes a volumetric test procedure for animal bedding (see page 13).
3. For the reasons described in the background of Section 3(b) (page 31), the OWM recommends that no enforcement action be taken on the 1 % percent Maximum Allowable Variation (MAV) in Table 2-6 (which covers most sizes of the expanded volume declarations on bedding packages) because that value is unreasonable. Instead, the OWM recommends a tentative MAV of 5 % be applied to single measurement determinations of bedding volume and a tentative MAV of 10 % be applied when multiple measurements are used to make volume determinations. OWM recommends these MAV values be used pending further studies of test data collected using large test measures, single measurement determinations and utilizing the new test procedure.
4. For the reasons described in the background of Section 3(e) (page 34), the OWM recommends that test measures not be filled by hand. Instead, the OWM recommends that compressed bedding be uncompressed in suitable sized chutes and then poured into a test measure (see page 39). As described on page 36, Section 3(f), pouring the bedding helps the product volume recover from the compression applied during packaging.
5. For the reasons described in the background of Section 3(h) (page 40), the OWM recommends that for official inspections the volume of the bedding in the test measure be determined without leveling the product and using a modified headspace method (based on NIST Handbook 133, Section 3.7. “Volumetric Test Procedure for Paint...”).
6. For the reasons described in the background of Section 3(i) (page 44), the OWM recommends that officials use a gravimetric auditing procedure to identify potentially short measure samples to reduce destructive testing and conserve inspection resources.
7. For the reasons described in the background of Section 3(j) (page 46), the OWM recommends that, unless the sample packages of animal bedding fail the dimensional test (of the compressed volume, that the final decision to accept or reject an Inspection Lot be based on the results of a test that verifies the expanded (uncompressed) volume declared on the package.

The current test procedure in NIST Handbook 133, Section 3.9. “Peat Moss” will be modified as shown:

### 3.9. Peat Moss

#### 3.9.1. Dimensional Test Procedure for Verifying the Compressed Packages

##### 3.9.1.1. Test Equipment

- Tape measure

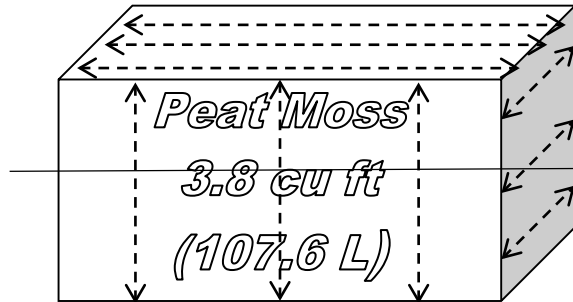

Figure 3-1. Peat Moss

##### 3.9.1.2. Test Procedure

- ~~7. Follow Section 2.3.1. "Define the Inspection Lot." Use a "Category A" sampling plan in the inspection; select a random sample.~~
- ~~8. For each dimension (length, width, and height) take three equidistant measurements.~~
- ~~9. Calculate the average of each dimension.~~
- ~~10. Multiply the averages to obtain the compressed cubic volume as follows:~~

$$\text{average height} \times \text{average width} \times \text{average length} = \text{cubic measurement}$$

- ~~11. Subtract the labeled volume from the measured volume to determine package error.~~

(Amended 2010)

##### 3.9.2. Uncompressed Volume Packages

Use the following method to test peat moss sold using an uncompressed volume as the declaration of content. The procedure as defined by the latest version of ASTM D2978-03, "Standard Test Method for Volume of Processed Peat Materials."

##### 3.9.2.1. Test Equipment

- 12.7 mm (or 1/2 in) sieve
- Use one of the following measures as appropriate for the package size. (Refer to Table 3-4. "Specifications for Test Measures for Mulch and Soils" for additional information on test measure construction.)

- ~~28.3 L (1 ft<sup>3</sup>) measure with inside dimensions of 30.4 cm (12 in) by 30.4 cm (12 in) by 30.4 cm (12 in). Mark the inside of the measure with horizontal lines every 1.2 cm (½ in) so that package errors can be directly determined~~
- ~~100 L (3.5 ft<sup>3</sup>) measure with inside dimensions of 50 cm (19.68 in) by 50 cm (19.68 in) by 40 cm (15.74 in). The inside of the measure should be marked with horizontal lines every 1.2 cm (½ in) so that package errors can be directly determined~~

- ~~Straight edge, 50.8 cm (20 in) in length~~
- ~~Sheet for catching overflow of material~~
- ~~Level (at least 15.24 cm (6 in) in length)~~

### ~~3.9.2.2. Test Procedure~~

- ~~7. Follow Section 2.3.1. “Define the Inspection Lot.” Use a “Category A” sampling plan in the inspection; select a random sample.~~
- ~~8. Open each package in turn, remove the contents, and pass them through the sieve directly into the measuring container (overfilling it). Use this method for particulate solids (such as soils or other garden materials) labeled in cubic dimensions or dry volume. Some materials may not pass through the sieve for peat moss; in these instances, separate the materials by hand (to compensate for packing and settling of the product after packaging) before filling the measure.~~

~~Note: Separated material (product not passing through the sieve) must be included in the product volume.~~

- ~~9. Shake the measuring container with a rotary motion at one rotation per second for 5 seconds. Do not lift the measuring container when rotating it. If the package contents are greater than the measuring container capacity, level the measuring container contents with a straightedge using a zigzag motion across the top of the container.~~
- ~~10. Empty the container. Repeat the filling operations as many times as necessary, noting the partial fill of the container for the last quantity delivered using the interior horizontal markings as a guide.~~
- ~~11. Record the total volume.~~
- ~~12. To compute each package error, subtract the labeled quantity from the total volume and record it.~~

### ~~3.9.3. Evaluation of Results~~

~~Follow the procedures in Section 2.3.7. “Evaluate for Compliance” to determine lot conformance for either procedure.~~

#### 3.9.1.1. Test Equipment

- Calculator or Spreadsheet Software (programmed to make volume calculations)



- **Volumetric Package Worksheet (Appendix C at end of this report)**
- **Non-permanent marking pen.**
- **Knife or Razor Cutter (for use in opening packages and unwrapping shrink-wrapped pallets in warehouses)**
- **Cellophane or Duct Tape (for use in securing packaging tails)**
- **Dimensional Measuring Frame (see Exhibit 1 and drawings at <https://www.nist.gov/owm> [to be posted])**



Exhibit 5. Picture of a Dimensional Measuring Frame.

- **Rigid Rulers – Starrett<sup>13</sup> or equal with 1.0 mm graduations. The edges of a ruler used with a measuring frame must be straight and the edges must be the zero point (see Exhibit 2).**
  - **300 mm (12 in)**
  - **500 mm (19.5 in)**
  - **1 m (39 inch)**
- **Carpenter Squares**
  - **300 mm (12 in)**

---

<sup>13</sup> Notice: The mention of trade or brand names does not imply endorsement or recommendation by the U.S. Department of Commerce over similar products available from other manufacturers.

- 600 mm (24 in)

### 3.9.1.2. Test Procedure

#### Note: Test Notes

**Rounding:** When a package measurement falls between graduations on a ruler, round the value up. This practice eliminates the issue of rounding from the volume determination and provides the packager the benefit of the doubt. If a ruler with a graduation of 1.0 mm is used, the rounding error will be limited to 0.5 mm or less. It is good practice to circle a measurement that has been rounded up or make a statement to such effect so that it becomes a part of the record.

**Dimension Identification:** The following package nomenclature is used to identify the dimensions measured in this test procedure.

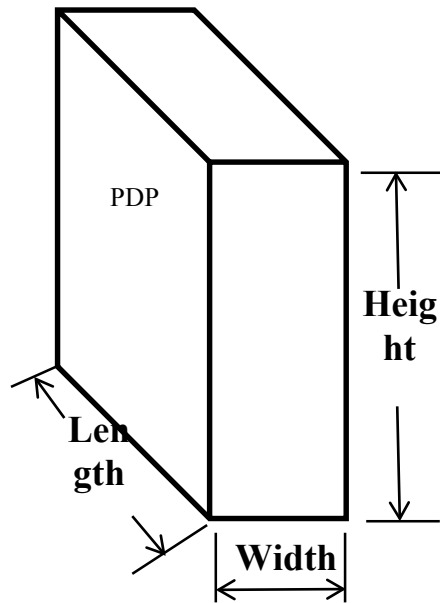

Figure 3-2. Dimension Identification.

**Note: Packages of compressed peat moss do not have declaration of expanded volume.**

#### Safety



**This procedure does not address all of the safety issues that users need to be aware of in order to carry out the following tasks. Users are sometimes required to conduct tests in warehouse spaces or retail stores where fork-trucks are in motion – care must be taken to warn others to avoid or exercise care around the test site. The procedure requires users to lift heavy objects including large bulky packages and test measures and includes the use of sharp instruments to obtain packages from shrink-wrapped pallets. Users may be required to climb ladders or work platforms to obtain sample packages. When opening and emptying packages, dust, or other particles may be present or escape from the packages, which may**

**cause eye injuries and respiratory or other health problems. Users must utilize appropriate safety equipment and exercise good safety practices. If safe working conditions cannot be ensured, suspend testing until the situation is corrected.**

- 6. Follow the Section 2.3.1. “Define the Inspection Lot.” Use a “Category A” Sampling Plan for the inspection. Collect the sample packages from the Inspection Lot using random sampling. If the packages are not randomly selected, the sample will not be representative of the lot and the test results will not be valid for use in enforcement action. Place the sample packages in a location where there is adequate lighting and ample space for the packages and test equipment.**
- 2. Examine the package for excess packaging material (i.e., packaging tails). Fold the packaging material consistent with design of the packaging and tape the material securely to the package so that its effect on the dimensional measurement is minimized. If the thickness of packaging tail appears excessive, it is appropriate to determine its average thickness by making at least three measurements along its length using a dead weight dial micrometer specified in Section 4.5. “Polyethylene Sheeting” and subtract the thickness from the measurement of length, width or height. Any deduction from a measurement should be noted on the inspection report.**
- 3. If a Dimensional Measuring Frame is used, place it on a solid support. If a table is used, select one of sufficient load capacity to hold the weight of the frame and the heaviest package to be tested.**
- 4. Position the frame so that the zero end of the ruler can be placed squarely and firmly against a surface of the frame and so that the ruler graduations can be read. Position yourself so that you can read both the ruler and the edge of the carpenter square in Exhibit 2.**
- 5. Place the package against two sides of the frame without compressing the package. Place a carpenter square against the package at the point of measurement and align the ruler perpendicular to the edge of the carpenter square as shown in Exhibit 3 where the package length and Exhibit 4 where the package height are being determined.**

**Using a Measuring Frame for Dimensional Testing  
Ruler and Carpenter Square define Zero Reference and Measurement Point**



Exhibit 6. The rigid frame allows the observer to hold the zero reference point firmly in place.



Exhibit 7. Length Measurement.



Exhibit 8. Height Measurement – A packaging tail on the end of the package can affect this measurement so it has been folded over and taped against the end of the package.



Exhibit 9. Width Measurement – the frame is rotated on its end to vertical so that the carpenter square does not compress the product.

**6. Measurements – take at least five measurements\* of each of the dimensions as follows:**

**\*On small packages (height or length dimensions of 152 mm [6 in] or less) at least three measurements are taken using the following the instructions).**

<b><u>Inspect the package for shape and place the flattest surfaces against the measuring frame.</u></b>	
<p><b>i.</b>     <b><u>Length (see Exhibit 3):</u></b></p> <p><b>a.</b>     <b><u>take the first measurement across the center line of the Length axis of package.</u></b></p> <p><b>b.</b>     <b><u>take the second measurement at half the distance between the center Line and either of the package edges.</u></b></p> <p><b>c.</b>     <b><u>take the third measurement half the distance between the second measurement and the package edge.</u></b></p> <p><b>d.</b>     <b><u>take the fourth measurement on the opposite end of the package at half of the distance between the center line and the package edge.</u></b></p> <p><b>e.</b>     <b><u>take the fifth measurement at half of the distance between the fourth measurement and the package edge.</u></b></p>	
<p><b>ii.</b>    <b><u>Height: (see Exhibit 4):</u></b></p> <p><b>a.</b>    <b><u>take the first measurement across the center line of the Height axis of the package.</u></b></p> <p><b>b.</b>    <b><u>take the second measurement at half the distance between the center line and the package edge.</u></b></p> <p><b>c.</b>    <b><u>take the third measurement half the distance between the second measurement and the package edge.</u></b></p> <p><b>d.</b>    <b><u>take the fourth measurement on the opposite end of the package at half of the distance between the center line and the package edge.</u></b></p> <p><b>e.</b>    <b><u>take the fifth measurement at half of the distance between the fourth measurement and the package edge.</u></b></p>	
<p><b>iii.</b>   <b><u>Width: (see Exhibit 5): If using one, turn the measuring frame on end and place the package on its bottom and against the frame as shown in the picture and on the right where the package width is being measured.</u></b></p> <p><b>a.</b>    <b><u>take the first measurement across the center line of Width axis of the package.</u></b></p> <p><b>b.</b>    <b><u>take the second measurement at half the distance between the center line and the package edge.</u></b></p> <p><b>c.</b>    <b><u>take the third measurement half the distance between the second measurement and the package edge.</u></b></p> <p><b>d.</b>    <b><u>take the fourth measurement on the opposite end of the package at half of the distance between the center line and the package edge.</u></b></p> <p><b>e.</b>    <b><u>take the fifth measurement at half of the distance between the fourth measurement and the package edge.</u></b></p>	

- 7. Record the dimensions of each package in millimeters in a software program or inspection form that includes the information shown in the sample worksheet “Calculate the Compressed Volume of the Package in Liters” (below). Enter the measurements in the appropriate spaces and calculate the volume in liters. Calculate the package error by following the steps listed in the table and then calculate the average error for the sample.**

**Note: The following table is an example of the information from an actual test that is included in a worksheet for verifying the compressed volume on packages of peat moss. The Inspection Worksheet for Dimensional Testing (see Appendix C) has space for a sample of 12 packages and includes the steps for calculating the Average Package Error. Here, the package error in the dimensional volume was + 6.8 L (+ 0.24 ft<sup>3</sup>). Apply a tentative MAV of 5 % to a dimensional measured volume.**

<b>SAMPLE WORKSHEET</b>			
<b>Calculate the Compressed Volume of the Package in Liters</b>			
<u>Unit of Measure = 1.0 mm</u>	<u>Length (L)</u>	<u>Width (W)</u>	<u>Height (H)</u>
<u>1.</u>	<u>482</u>	<u>282</u>	<u>690</u>
<u>2.</u>	<u>490</u>	<u>278</u>	<u>690</u>
<u>3. (Center Line)</u>	<u>493</u>	<u>276</u>	<u>681</u>
<u>4.</u>	<u>499</u>	<u>272</u>	<u>677</u>
<u>5.</u>	<u>493</u>	<u>269</u>	<u>657</u>
<u>a. Average:</u>	<u>491</u>	<u>275.4</u>	<u>679</u>
<u>b. L × W × H = Volume/1 000 000</u>	<u>91.8 L</u>		
<u>c. Labeled Compressed Quantities:</u>	<u>85 L</u>	<u>NA cu in</u>	<u>3.0 cu ft</u>
<u>d. Conversion Factors</u>	<u>NA</u>	<u>(b) × 61.02374</u>	<u>(b) × 0.03531467</u>
<u>e. Converted Volume</u>	<u>85 L</u>	<u>NA cu in</u>	<u>3.24 cu ft</u>
<u>f. Package Error = (b – c)</u>	<u>6.8 L</u>	<u>NA cu in</u>	<u>0.24 cu ft</u>

### 3.9.2. Uncompressed Volume Packages

Use the following method to test peat moss sold using an uncompressed volume as the declaration of content. The procedure as defined by the latest version of ASTM D2978-03, “Standard Test Method for Volume of Processed Peat Materials.

#### 3.9.2.1. Test Equipment

- 12.7 mm (or ½ in) sieve
- Use ~~a one of the following test~~ measure appropriate for the package size. (Refer to Table 3-4. “Specifications for Test Measures for Mulch and Soils” for additional information on test measure size and construction.)
  - ~~28.3 L (1 ft<sup>3</sup>) measure with inside dimensions of 30.4 cm (12 in) by 30.4 cm (12 in) by 30.4 cm (12 in). Mark the inside of the measure with horizontal lines every 1.2 cm (½ in) so that package errors can be directly determined~~
  - ~~100 L (3.5 ft<sup>3</sup>) measure with inside dimensions of 50 cm (19.68 in) by 50 cm (19.68 in) by 40 cm (15.74 in). The inside of the measure should be marked with~~

~~horizontal lines every 1.2 cm (1/2 in) so that package errors can be directly determined~~

- Straight edge, 50.8 cm (20 in) in length
- Sheet for catching overflow of material
- Level (at least 15.24 cm (6 in) in length)

### 3.9.2.2. Test Procedure

1. Follow Section 2.3.1. “Define the Inspection Lot.” Use a “Category A” sampling plan in the inspection; select a random sample.
2. Open each package in turn, remove the contents, and pass them through the sieve directly into the measuring container (overfilling it). Use this method for particulate solids (such as soils or other garden materials) labeled in cubic dimensions or dry volume. Some materials may not pass through the sieve for peat moss; in these instances, separate the materials by hand (to compensate for packing and settling of the product after packaging) before filling the measure.

**Note:** Separated material (product not passing through the sieve) must be included in the product volume.

3. Shake the measuring container with a rotary motion at one rotation per second for five seconds. Do not lift the measuring container when rotating it. If the package contents are greater than the measuring container capacity, level the measuring container contents with a straightedge using a zigzag motion across the top of the container.
4. Empty the container. Repeat the filling operations as many times as necessary, noting the partial fill of the container for the last quantity delivered using the interior horizontal markings as a guide.
5. Record the total volume.
6. To compute each package error, subtract the labeled quantity from the total volume and record it.

### 3.9.3. Evaluation of Results

Follow the procedures in Chapter 2, Section 2.3.7. “Evaluate for Compliance” to determine lot conformance.

**Note: To determine the value of the MAV look up the labeled quantity in Appendix A, Table 2-6. Maximum Allowable Variations for Packages Labeled by Liquid and Dry Volume.**

### Section 3.15. Test Procedure for Verifying the Expanded Volume Declaration on Packages of Animal Bedding

#### 3.15.1. Test Equipment

- Calculator or Spreadsheet Software
- Modified Standard Package Report Form – Appendix D (at end of report).
- Package Inspection Worksheet Appropriate for Test Measure:
  - Appendix A – 26 Point Measurement Grid and Package Error Worksheet for Cylindrical Test Measures (at the end of the report)
  - Appendix B – 25 Point Measurement Grid and Package Error Worksheet for Square or Rectangular Test Measures (at the end of the report)
- Permanent Ink - Marking Pen.
- Knife or Razor Cutter (for use in opening packages and unwrapping shrink-wrapped pallets in warehouses)
- Cellophane Tape, Duct Tape (for repairing chutes and sealing packages)
- Polyethylene Bags (49 L to 113.5 L [13 gal to 30 gal]) (to hold product once it is uncompressed)
- Rigid Rulers – Starrett<sup>14</sup> or equal with 1.0 mm graduations. The edges of a ruler used with a measuring frame must be straight and the edges must be the zero point (see Exhibit 2).
  - 300 mm (12 in)
  - 500 mm (19.5 in)
  - 1 m (39 in)
- Tarp - Canvas 3 m × 3 m (10 ft × 10 ft)
- Broom and Dust Pan
- Levels – for verifying the level of the test measure and taking headspace readings.
  - 152 mm (6 in) Bubble Level
  - 1 m (40 in) Carpenter Level
- Scale 15 kg (30 lb) (only used if the audit procedure is utilized.)

---

<sup>14</sup> Notice: The mention of trade or brand names does not imply endorsement or recommendation by the U.S. Department of Commerce over similar products available from other manufacturers.



- Chutes for Uncompressing and Pouring the Bedding into a Test Measure

Nominal Capacity	Height	Width	Length
70 L (2.5 ft <sup>3</sup> )	254 mm (10 in)	228 mm (9 in)	1219 mm (48 in)
100 L (3.5 ft <sup>3</sup> )	254 mm (10 in)	279 mm (11 in)	1397 mm (55 in)
170 L (6 ft <sup>3</sup> )	279 mm (11 in)	355 mm (14 in)	1727 mm (68 in)
240 L (8.5 ft <sup>3</sup> )	304 mm (12 in)	406 mm (16 in)	2006 mm (79 in)
283 L (10 ft <sup>3</sup> )	304 mm (12 in)	406 mm (16 in)	2286 mm (90 in)

**NOTE:** Chutes (see examples below) may be constructed using hinges and pins so that they lie flat for transporting. They can be constructed of sheet metal or with other slick surface material which enable the bedding to flow easily. The construction of the chutes used in this study allows the sides to move in or out slightly so that the bedding does not become clogged at the outlet. The heights and lengths may be adjusted slightly to fit into vehicles for transport but the widths should not be reduced because narrowing the opening can restrict material flow and result in “bridging” where the bedding collects and creates a block. Also, the width should be kept smaller than the opening of the test measure so that spillage does not occur during pouring.



**Figure 3. Testing Chutes.**

- Test Measures (see Table 2. “Test Measures for Animal Bedding”)

**Table 2. Test Measures for Animal Bedding** NOTES: a, b, c, and d

Only Interior Dimensions Are Used for Volume Calculations  
Must Be Calibrated with Traceable Measurement Standards Prior to Use

Rectangular & Square Test Measures						
Actual Volume of the Measure <sup>b &amp; d</sup>	Interior Wall Dimensions			Surface Area	Marked Increments on Ruler	Increment Volume
	Length	Width	Height <sup>d</sup>			
31.9 L 1.13 ft <sup>3</sup>	213.4 mm (8.4 in)	203.2 mm (8 in)	736.6 mm (29 in)	43 362 mm <sup>2</sup> (67.2 in <sup>2</sup> )	12.7 mm (0.5 in)	550.6 mL* 0.55 L (33.6 in <sup>3</sup> )
28.3 L 1 ft <sup>3</sup>	304.8 mm (12 in)	304.8 mm (12 in)	304.8 mm (12 in)	92 903 mm <sup>2</sup> (144 in <sup>2</sup> )		1.18 L** (72 in <sup>3</sup> )
63.7 L 2.25 ft <sup>3</sup>	304.8 mm (12 in)	304.8 mm (12 in)	685.8 mm (27 in)			
	406.4 mm (16 in)	228.6 mm (9 in)	685.8 mm (27 in)			
92 L 3.25 ft <sup>3</sup>	304.8 mm (12 in)	304.8 mm (12 in)	990.6 mm (39 in)			
	406.4 mm (16 in)	228.6 mm (9 in)	990.6 mm (39 in)			
*1.0 mm = 43 mL (2.6 cu in) ** 1.0 mm = 92 mL or 0.09 L (5.6 cu in)						
Square Test Measures						
Actual Volume of the Measure <sup>b &amp; d</sup>	Interior Wall Dimensions			Surface Area	Marked Increments On Ruler	Increment Volume
	Length	Width	Height <sup>d</sup>			
77.4 L (2.73 ft <sup>3</sup> )	381 mm (15 in)	381 mm (15 in)	533.4 mm (21 in)	145 161 mm <sup>2</sup> (225 in <sup>2</sup> )	1.0 mm (0.03937 in)	0.14 L (8.5 in <sup>3</sup> )
144 L (5.09 ft <sup>3</sup> )	508 mm (20 in)	508 mm (20 in)	558.8 mm (22 in)	258 064 mm <sup>2</sup> (400 in <sup>2</sup> )		0.25 L (15.2 in <sup>3</sup> )
283 L (10 ft <sup>3</sup> )	609.6 mm (24 in)	609.6 mm (24 in)	762 mm (30 in)	371 612 mm <sup>2</sup> (576 in <sup>2</sup> )		0.37 L (22.5 in <sup>3</sup> )

This publication is available free of charge from: <https://doi.org/10.6028/NIST.SP.1210>

**Table 2. Test Measures for Animal Bedding** NOTES: a, b, c, and d

Only Interior Dimensions Are Used for Volume Calculations  
 Must Be Calibrated with Traceable Measurement Standards Prior to Use

**Cylindrical Test Measures**

These dimensions are based on the tube having a ¼ inch wall thickness. Other tube thicknesses may be used.

Actual Volume <i>Volume = <math>\pi r^2 h</math></i>	Interior Diameter (Outside Diameter)	Height	Surface Area <i>Area = <math>\pi r^2</math></i>	Increment	Increment Volume
52 L (1.8 ft <sup>3</sup> )	292.1 mm (304.8 mm) 11.5 in (12 in)	780 mm (30.70 in)	67 012 mm <sup>2</sup> (103.8 in <sup>2</sup> )	1.0 mm (0.03937 in)	0.06 L (4 in <sup>3</sup> )
124 L (4.3 ft <sup>3</sup> )	444.5 mm (457.2 mm) 17.5 in (18 in)	800 mm (31.49 in)	155 179 mm <sup>2</sup> (240.52 in <sup>2</sup> )		0.15 L (9.4 in <sup>3</sup> )
279 L (9.8 ft <sup>3</sup> )	596.9 mm (609.6 mm) 23.5 in (24 in)	1000 mm (39.37 in)	279 829 mm <sup>2</sup> (433.76 in <sup>2</sup> )		0.27 L (16.4 in <sup>3</sup> )

**Notes for Table 2:**

- a. Rectangular and Square Based Dry Measures are typically constructed of 12.7 mm to 19.05 mm (0.5 in to 0.75 in) Marine Plywood. A 4.76 mm (<sup>3</sup>/<sub>16</sub> in) transparent sidewall is useful for determining the level of fill, but must be reinforced or be made of thicker material if it distorts when the measure is filled. If the measure has a clear front, place the level gage at the back (inside) of the measure so that the markings are read over the top of the animal bedding. Any of these measures may be made without an attached bottom for ease of emptying if they are placed on a solid level base during filling and measurement.
- b. Other size measures may be used if calibrated and the volume equivalence of the increment of 1.0 mm is no greater than 1/6 the MAV. Widening the base of a measure reduces the column height of the product and will reduce compression but the trade-off is that the larger surface area increases the volume so the potential for measurement errors increase. One of the benefits of the cylindrical design is that, in addition to eliminating the 90 degree angles of the corners where gaps in fill frequently occur, the surface area of a cylinder is less than an equal volume square measure and that results in better resolution in the volume measurements (i.e., compare the readability of a 24 in sq box which has a surface area of 576 in<sup>2</sup>, to the 24 in cylinder which has a surface area of 433 in<sup>2</sup>). The height of the test measure may be reduced, but this will limit the volume of the package that can be tested.
- c. If lines are marked in any test measures, they should extend around all sides of the measure if possible to improve readability. It is recommended that a line indicating the MAV level also be marked to reduce the possibility of reading errors when the level of the product is at or near the MAV.
- d. If the measures are built to the dimensions shown above, the actual volume of most of the measures will be larger than the nominal volume so that plus errors (overfill) can be measured accurately.

**3.15.2. Test Procedure**

**Test Notes:**

**Rounding:** When a volume measurement falls between graduations on a ruler, round the value in the direction that favors the packer. This practice eliminates the issue of rounding from the volume determination and provides packagers the benefit of the doubt. The ruler graduation is

1.0 mm so the rounding error will be limited to 0.5 mm or less. It is good practice to circle a measurement that has been rounded up or make a statement to such effect so that it becomes a part of the inspection record.

**Safety:**



This procedure does not address all of the safety issues that users need to be aware of in order to carry out the following tasks. Users are sometimes required to conduct test in warehouse spaces or retail stores where fork-trucks are in motion – care must be taken to warn others to avoid or exercise care around the test site. The procedure requires users to lift heavy objects including large bulky packages and test measures and includes the use of sharp instruments to obtain packages from shrink-wrapped pallets. Users may be required to climb ladders or work platforms to obtain packages. When opening and emptying packages, dust, and other particles may be present or escape from the packages which may cause eye injuries and respiratory or other health problems. Users must utilize appropriate safety equipment and exercise good safety practice. If safe working conditions cannot be ensured, suspend testing until the situation is corrected.

8. Follow the Section 2.3.1. “Define the Inspection Lot,” select “Category A – Sampling Plan” in this Inspection. Determine the Sample Size based on the size of the Inspection Lot using Category A. Collect the sample packages from the Inspection Lot using Section 2.3.4. “Random Sampling Selection.”

**Test Note:** Place the test equipment and sample packages in a location where there is adequate lighting and ample space around the packages and equipment so the packages can be opened and the chutes and test measures used safely.

**Optional – Audit Screening by Weight**

The full test procedure requires that all of the packages be opened for testing. Regardless of the type of bedding, the product cannot be returned to the original package. An alternative gravimetric auditing procedure may be used to reduce the amount of destructive testing and conserve inspection resources.

**Audit Procedure:** After randomly selecting the sample packages from the Inspection Lot, obtain the gross weight for each package. Select the lightest and heaviest packages and conduct an expanded volumetric test on these two packages. If the lightest and heaviest packages pass (i.e., each contains at least the expanded volume declared on the label), it is highly likely that the remaining packages in the sample will also pass. Accept these two package samples as an AUDIT TEST and move on to inspect other types of bedding or Inspection Lots of other types or brands of bedding. If either of the two packages is found to have a minus error that exceeds the Maximum Allowable Variation, the sample fails. No further testing is required (i.e., assuming no MAV is allowed for the sample size (see Appendix A, Table 2-1. “Sampling Plans for Category A”). If either of the packages is found to have a minus error that does not exceed the MAV, continue to test all of the packages and take action based on the final results from the complete sample.

**Test Note:** If the gravimetric audit procedure is used, ensure that the scale is placed on a solid level support and that its accuracy has been verified to a test load that is at least 10 percent more than the gross weight of the packages (e.g., to estimate that load, place one of the packages on the scale and then test the scale with a load above the package’s gross weight). See Section 2.2. “Measurement Standards and Test Equipment” for additional information.

9. Select the appropriate test measure for the package size.

- Spread a tarp large enough to hold a chute and test measure.
- Place the chute and test measure on the tarp. Verify that the test measure is level.

10. Select a chute of appropriate capacity (see Table 1) for the package size and position it on the tarp.

11. Open the Packaging, Uncompressing and Pouring the Bedding into the Test Measure Twice.

- **Open Package:** Place the package in the chute and use a knife or box cutter to open and remove the wrapper. Spread the bedding uniformly along the length of the chute. The bedding is uncompressed in two steps. The first step is to loosen the clumps of bedding by gently pulling them apart (do not tear the fibers of cellulose bedding or “grind” any bedding between your hands because these practices break the material down). Spread your fingers and pick the material up using your hands from beneath to loosen it up. There should be no clumps of bedding in the chute. If any bedding has fallen out of the chute onto the tarp, collect it and return it to the chute. The following pictures illustrate this step of the procedure. The second step of the expanded volume recovery process is to pour the bedding into a test measure as described in Step 2.

Exhibit 10.



Exhibit 11.



**Exhibit 12. First pour into the test measures.**

- **First Pour:** The first pour into the test measure is only used to further un-compress the bedding so no measurements are taken. Hold the chute above the test measure and tilt it so that you pour the bedding into the center of the test measure. The bedding should be poured slowly into the test measure in one continuous stream and not “dumped” (if it is “dumped” or poured too quickly some of the bedding will blow out of the measure or the bedding will be packed down and its volume reduced). The flow rate should be controlled by the tilt angle of the chute. The chute itself can be shaken but **DO NOT HIT OR SHAKE THE TEST MEASURE.** (Do not adjust the flow by closing the opening of the chute as that may cause the bedding to heap up and then fall into the measure in clumps which may result in impact compression). Empty the bedding back into the chute and spread it out evenly along its length.



**Exhibit 13. Showing how to hold a chute for the pour.**



**Exhibit 14. Showing how to cradle the chute on one arm and holding it with one hand while tilting it with the other hand.**

- **Second Pour:** The second pour into the test measure is used to make the volume determination. Hold the chute above the test measure and tilt it so that you pour the bedding into the center of the test measure. The bedding should be poured slowly into the test measure in one continuous stream and not “dumped.” The flow rate should be controlled

by the tilt angle of the chute. The chute can be shaken but **DO NOT HIT OR SHAKE THE TEST MEASURE.**

**Test Note:** Stop filling the measure if it appears that the test measure will overflow. The overflow product should be measured separately (use a smaller test measure of adequate size and capacity if one is available) and the multiple measurement volumes are added. If pouring into a square test measure, pour at an angle to two corners for the widest opening (see Exhibit 12).



Exhibit 15. Filling a 44 L Test Measure.



Exhibit 16. Filling a Square Test Measure at an Angle to use the Larger Opening.

## 12. Volume Determination.

**DO NOT HAND LEVEL THE SURFACE OF THE BEDDING AS MANUAL LEVELING “PACKS” THE BEDDING AND REDUCES ITS VOLUME. DO NOT JAR OR SHAKE THE TEST MEASURE**

**Test Note:** Before using a test measure for volume determinations, place a level of adequate length on top of the test measure at five approximately equal measuring points across the top. A permanent marking pen can be used to evenly space the marks across the top edge of the test measure so that it can be positioned to take the measurements (see Exhibit 13).



**Exhibit 17. Marking the evenly spaced measuring points across the top of the test measure.**

- Place a rigid level or straight edge of adequate size on top the test measure and select a ruler of adequate length to reach to the lowest level of the top surface of the bedding. Start at the measuring points to your left or right, place the ruler against the side of the level, and hold it with either hand. The zero graduation is pointed down so the ruler can be lowered into the test measure for measurement. Lower the ruler into the test measure slowly until its end is at the surface level of the bedding (see Exhibits 14 and 15).



**Exhibit 18. Placing ruler into the test measure with zero end down.**



**Exhibit 19. Ruler shown with zero end at surface of the bedding.**

- Determine the depth of each measurement point from the surface of the bedding to the bottom edge of the straight edge and record the value in the appropriate space on the worksheet. Take a minimum of 25 measurements (at least 26 for cylindrical measures) across the top of the test measure in a grid pattern. Read the graduations on the ruler from a position that minimizes errors caused by parallax.



**Table 2. Illustrations of Depth Determinations with Cylindrical Test Measures**



**Figure 1.** Shows how to read the depth of container.

The picture on the left (Figure1) shows how to read the depth from the bottom of the straightedge (top edge of measure) down to the bedding in a 44 L test measure from a position that reduces parallax. The graphic below (Figure 2) illustrates the actual worksheet with the headspace procedure on the 44 L cylinder test measure (its internal radius is 151.5 mm and its height is 610 mm). The bedding was poured into the test measure but not leveled. Then 26 measurements were made at the locations shown on the grid to determine the depth of the product from the top edge of the measure. The average of the 26 values was 500.7 mm which was subtracted from the height of the test measure to obtain 109.3 mm for the average height of the column of bedding in the measure.

The volume was calculated using:

$$Volume \text{ in liters} = \pi r^2 h \quad 3.14159265 \times 22952 \times 109.3 \text{ mm} = 7.88 \text{ L}^*$$

\*After the calculation was completed the result was divided by 1 000 000 to obtain the volume in liters.

**Figure 4.** Illustration of Worksheet.

	413	367	390	
439	439	430	419	432
478	475	492	462	478
552	542	528	532	530
578	580	577	569	565
	589	590	573	

**Table 2. Illustrations of Depth Determinations  
with Cylindrical Test Measures**



**Figure 5. Using the headspace measurement on a 279 L test measure. The ruler is read from the bottom edge of a straight edge or level from a position that reduces parallax.**



**Figure 4. Illustrating how the ruler is placed on the bedding with the headspace method. The ruler is read from the bottom edge of a straight edge or level from a position that reduces parallax.**

**Table 3. Illustrations of Depth Determinations with Square Test Measures**



**Figure 1.**

246	162	81	132	177
195	115	43	46	112
111	77	51	95	146
220	138	46	98	131
264	193	118	148	180

**Figure 2.**

The picture on the left (Figure 1) shows how to read the depth from the bottom of the straightedge (top edge of measure) down to the bedding in a 283 L square test measure from a position that reduces parallax. The graphic on the right (Figure 2) illustrates the actual worksheet with the headspace procedure on the square test measure (its internal dimensions are 609.6 mm × 609.6 mm × 762 mm (24 in × 24 in × 30 in). The bedding was poured into the test measure but not leveled. Then 25 measurements were made at the locations shown on the grid to determine the depth of the product from the top edge of the measure. The average of the 25 values was 133 mm that was subtracted from the height of the test measure to obtain 629 mm for the average height of the column of bedding in the measure.

The volume was calculated using: Volume in liters = lwh 609.6 mm × 609.6 mm × 629 mm = 233.74 L\*

\*After the calculation was completed, the result was divided by 1 000 000 to obtain the volume in liters.



**Figure 3. Using the headspace measurement on 56.6 L (2 cu ft) test measure. The ruler is read from the bottom edge of a straight edge or level from a position that reduces parallax.**

**Table 3. Illustrations of Depth Determinations with Square Test Measures**

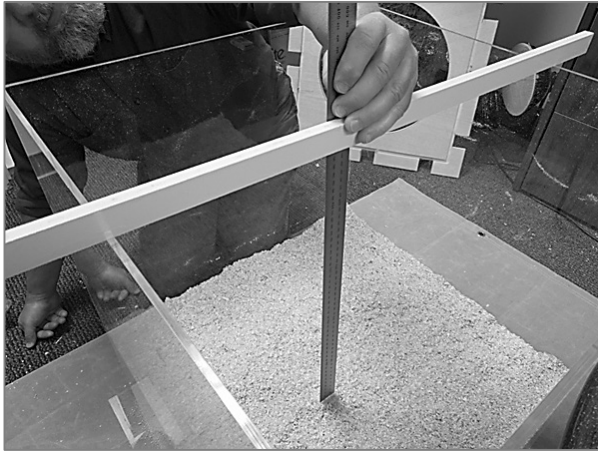

**Figure 4. Showing how the ruler is placed on the bedding with the headspace method. The ruler is read from the bottom edge of a straight edge or level from a position that reduces parallax.**

### 13. Using a Worksheet for Volume Calculation

- Enter the sample number of the package on the worksheet along with its labeled expanded volume.
- Test Measure Information
  - For a cylindrical test measure, enter its interior height and radius in the spaces labeled A and B.
  - For a square or rectangular test measure enter its interior height and the area of its base (i.e., length × width) in spaces labeled A and B.
- Sum the measurements in the grid, divide the value by the number of measurements (i.e., 25 or 26), and enter this value in the space labeled C, Average Depth.
- Calculate the Average Height of the Bedding (subtract C [Average Depth] from A [Interior Height of Test Measure]) and enter this value in the space labeled D.
- Calculate the Volume of Bedding in the Package:
  - For a cylindrical test measure, the formula (*Volume in Liters =  $\pi r^2 h$* ) is shown in E on the worksheet. It is *Volume (Liters) = 3.14159265 × r<sup>2</sup> (B<sup>2</sup>) \_\_\_\_ × Average Height (D) \_\_\_\_ ÷ 1 000 000*. Enter the package volume in the space provided for this value in E.
  - For a square or rectangular test measure the formula (*Volume in Liters = LWH*) is shown in E on the worksheet. It is *Volume (Liters) = B (Area of Test Measure Base) \_\_\_\_ × D (Average Height) \_\_\_\_ ÷ 1 000 000*. Enter the package volume in the space provided for this value in E.
- Calculate the Package Error using the following formula:

- Package Error = Labeled Expanded Volume (Liters) \_\_\_\_ – E Package Volume (Liters) \_\_\_\_

$$\text{Package Error (Liters)} = \text{Labeled Expanded Volume} - \text{Package Volume}$$

- Transfer the individual package errors (verify whether they are positive or negative) to the “Modified Standard Package Report for Animal Bedding” in Appendix D. Fill in the required header information. For Box 7, “Number of Unreasonable Package Errors Allowed for Sample Size,” use Appendix A, Table 2-1. “Sampling Plans for Category A, Column 4.” Based on the sample size, determine how many packages may have minus package errors that exceed the MAV (i.e., unreasonable package error). Then:
  - Calculate the Total Error (Enter in Box 8 “Total Error”).

#### 14. Evaluation of the Test Results and Determination of Pass or Fail

- Determine if any of the minus package errors exceeds the MAV. Apply a tentative MAV value of 5 % ( $0.05 \times$  labeled expanded volume) to single measurement volume determinations and a tentative MAV value of 10 % ( $0.10 \times$  labeled expanded volume) on multiple-measurement volume determinations (enter in Box 4 “MAV”). If none of the minus package errors exceeds the MAV, go to Step 3. If any of the minus package errors exceed the MAV, enter the number of packages in Box 9 “Number of Unreasonable Minus Errors.” Go to Box 10 “Is Box 9 Greater than Box 7?” and determine if the value exceeds the number in Box 7 “Number of Unreasonable Package Errors Allowed for Sample Size.” If the number of packages with unreasonable errors exceeds the number permitted in Box 7 “Number of Unreasonable Package Errors Allowed for Sample Size,” the sample fails. Go to Box 17 “Disposition of the Inspection Lot” and reject the Inspection Lot.
- Calculate the Average Error for the sample by dividing Box 8 “Total Error” by Box 6 “Sample Size” and enter the value in Box 11 “Calculate Average Error,” then go Box 12 “Does Box 11 equal Zero or Plus?” If the Average Error is zero or a positive number, the sample passes, go to Box 17 “Disposition of the Inspection Lot” and approve the Inspection Lot. If the Average Error is a negative value go to Step 4.
- Calculate the Sample Standard Deviation and enter in Box 13 “Compute Sample Standard Deviation.” To obtain the Sample Correction Factor for the sample size use Appendix A, Table 2-1. “Sampling Plans for Category A,” Column 3 “Sample Correction Factor” and enter that in Box 14 “Sample Correction Factor.” Then calculate the Sample Error Limit by multiplying Box 13 “Compute Sample Standard Deviation” and Box 14 “Sample Correction Factor.” Enter the value in Box 15 “Compute Sample Error Limit.”
- Disregarding the signs, determine if the minus in Box 11 “Calculate Average Error” is larger than the value in Box 15 “Compute Sample Error Limit.”
  - If yes, the sample fails, go to Box 17 “Disposition of Inspection” and reject the Inspection Lot.
  - If no, the sample passes, go to Box 17 “Disposition of Inspection” and approve the Inspection Lot

- Prepare a comprehensive report of the test results and enforcement action taken and present the information to the party responsible for the product.

## Background

### 1. Animal Bedding

Animal Bedding (Bedding), also called pet or stall bedding, litter or simply bedding, is generally sold by dry volume in compressed or uncompressed packages. A survey of several Internet retailers and retail stores conducted near the NIST revealed that a few packers sell bedding (e.g., pelletized) by net weight, which is prohibited by the current method of sale. Quantity declarations are often presented in a mixture of customary volume measurements including dry quart, cubic inch, and the cubic foot. Quantity declarations in metric units are predominantly by the liter and milliliter. For compressed packages, a declaration of both the compressed volume and uncompressed volume is required according to the NIST Handbook 130, Section B. Uniform Method of Sale of Commodities, 2.23. “Animal Bedding.” Package sizes vary widely. For example, compressed volumes can range from about 4 L (230 cu in) to 85 L (3 cu ft). The uncompressed (expanded) volumes can range from about 6 L (600 cu in) up to 340 L (12 cu ft). It is consumer preference that determines how much bedding is used to “surface” a cage or stall. Unlike compressed peat moss, which is also labeled in volume, there are no user instructions on packages of bedding recommending a specific depth for a consumer to fill a cage or litter box or to “surface” a stall (see Section 2. “Method of Sale and Terminology” for more on this subject). Also, unlike packages of peat moss, the shape of packages of bedding is subject to wide variations due to the packaging stretching and plumping because of the pressure exerted by the compressed material they hold. Several manufacturers describe the “ideal” bedding as having minimal dust and “fines” (small particles of the bedding material), a moisture of 8 % to 15 %, and good “loft” so that the product provides good absorption of liquids.

### 2. Method of Sale and Terminology

#### a. Compressed Volume Declaration

The presence of a declaration of compressed volume is of little or no value to consumers. Several packers were asked what value was the compressed volume information to consumers. The unanimous response was that a compressed volume declaration does not help consumers to make value comparisons and it is ineffective in preventing unfair competitive practices. The packers agreed that it is the expanded volume declared on packages of bedding that is the most useful information for consumers. The primary reason is that it helps the purchaser estimate the size of package to buy or how many packages are needed to “bed” a cage or “surface” a stall. The area coverage obtained from a compressed package depends in large part on the characteristics of the material and the packaging process (e.g., force of compression). An expanded volume declaration is the only quantity declaration that is reliable and that aids consumers. Even a net weight declaration on bedding packages would not be useful. This is because the bedding in a heavier package may not expand as much as the bedding in a lighter package. For example, in this study packages of one product were found to vary in weight by only one or two grams but differed in volume yields by almost two liters. For bedding the weight/volume relationship is counter-intuitive because of variations in the raw material, moisture content; the size of the material, “fines” or small particles, and the amount of “dust” that varies from package to package. Packers and consumers alike would benefit if the National Conference on Weights and Measures (NCWM) would remove the requirement for a compressed volume declaration from the method of sale regulation and require bedding to be advertised, sold and unit priced on the basis of the expanded (uncompressed) volume declaration.

**NOTE:** At the beginning of this study the OWM reviewed the existing dimensional test procedures in Section 3.9. “Peat Moss” and found the procedures lacked some generally accepted good practices inherent in dimensional metrology to reduce measurement uncertainty. As a result, OWM developed a new dimensional test procedure for use in verifying the compressed volume of packages of bedding

that is a significant improvement over the current method in Section 3.9. “Peat Moss.” It was only during the second phase of the study that it became clear that it was the expanded volume test that was critical in ensuring that consumers receive full measure. If the recommendation to remove the compressed volume declaration requirement for packages of bedding is not accepted, the proposed dimensional test methods and equipment recommendations will improve the measurement process and increase the accuracy of volumetric results for packages of bedding and peat moss alike. If the requirement for bedding packages to include a compressed volume declaration is eliminated, the OWM recommends Section 3.9. “Peat Moss” be amended to adopt the proposed dimensional test procedure.

#### **b. Proposed Terminology and Prohibited Terms**

Typically bedding is a material offered for sale for use with pets, animals, reptiles, birds or other creatures but it may be offered for sale for other purposes such as providing a ‘surface’ for stalls, paddocks or arenas. Bedding or surfacing materials may be used with horses, dogs, cats, birds, ferrets, rabbits, guinea pigs, exotic animals, chinchillas, hamsters, rats, gerbils, mice, turtles, snakes and many other creatures from the wild or domesticated pets and farm animals. The following suggested definition is written to include any material intended for use with any creature that is labeled by volume but is not intended to apply to straw or hay sold by the bale.

#### **Definition of Animal Bedding**

In 2013 the NCWM considered the following definition for Animal Bedding but did not accept it. The NCWM’s reticence was only due to concerns that the proposal might not cover all types of animal bedding.

*Animal bedding is defined as “any product or material, except for baled straw or peat moss, that is advertised, offered for sale, or sold for primary use as a medium for animals to bed, nest or eliminate waste, such as compressed wood pulp or cellulose fibers (confetti, granules, or pellets), softwood shavings, shredded paper, compressed coconut fiber, ground corn cob, pelleted paper or wheat straw, cotton fibers, and bamboo products or any other material.”*

While an all-encompassing list of raw materials helps improve clarity, manufacturers are always identifying new raw materials for use as bedding. The NCWM usually chooses open-ended definitions for products to be covered by a method of sale. This places more emphasis on the way that the product is used to be determinative of whether or not a product falls under a method of sale so there are no “loopholes” and packers understand what is expected. Adopting a definition that is all inclusive of the raw materials that are currently used to make bedding as well as still being able to encompass new materials that may enter the stream of production is the most flexible and efficient approach.

The OWM recommends the following:

**Animal Bedding** – any material, except baled straw, that is kept, offered, or exposed for sale or sold for primary use as a medium for any companion or livestock animal to nest or eliminate waste.

#### **Units of Measure**

The Federal Trade Commission considers “pet care” products to be exempt from its regulatory control under the Fair Packaging and Labeling Act. Because the labeling of bedding falls solely under the jurisdiction of states who have adopted the Uniform Packaging and Labeling Regulation (UPLR) in NIST



Handbook 130, “Uniform Laws in the Areas of Legal Metrology...,”<sup>15</sup> the display of customary units is optional. Since 1999 the UPLR has required metric units to be declared on all packages which fall under its regulations but it also allows packagers the option of displaying customary units such as the cubic foot or cubic inches. As a result, quantity declarations may be shown on packages of bedding in terms of the milliliter (mL), liter (L), or cubic meter (m<sup>3</sup>). As currently written, the method of sale for bedding in Section 2.23. of the Method of Sale of Commodities Regulation in NIST Handbook 130 requires units in both systems of measurement to be displayed. That provision is inconsistent with the requirements in the UPLR that were adopted to encourage the use of voluntary metric only labeling. Also the current regulation does not prohibit the use of other customary dry measurements such as the dry quart or bushel which, if used instead of liters, cubic inches, or cubic feet, may frustrate value comparisons since most consumers may not know the volume of a dry quart and bushel are equivalent to 0.388 cubic foot and 1.244 cubic feet respectively.

### **Proposed Method of Sale**

A proposal to revise the current method of sale in Section 2.23. “Animal Bedding” is presented below. The proposal includes a new definition for “animal bedding,” limits the units of measure that can be used, and includes other restrictions to ensure that label terms are used consistently. The requirement for a “compressed volume” declaration of quantity is eliminated. The proposal replaces the term “usable” with the term “expanded volume.” The term “expanded volume” is preferred because it informs consumers that the quantity declaration represents the volume of product to be recovered once it is unwrapped and uncompressed. The proposal requires the use of the term “expanded volume” only in conjunction with the quantity statement on the lower 30 % of the Principal Display Panel and does not prohibit the use of the terms “compressed,” “expands to,” or “usable” elsewhere on the label. However, the proposed language prohibits the display of “pre-compression” and “compressed” volume declarations anywhere on the package. Finally, it clarifies that metric units are required to appear on the Principal Display Panel and that specific customary units such as cubic inches and cubic feet (e.g., dry quart and bushel are not permitted to appear on the package) may be included at the option of the packer. Because these products will all bear expanded volume in metric units and because consumers have a good comprehension of the volume contained in a liter, OWM is recommending that the method of sale include a provision that, while it does not require unit prices be posted, requires all unit pricing when it is voluntarily provided by the retailer be unit priced on the basis of price per liter.

#### **2.23. Animal Bedding.**

##### **2.23.1. Definitions.**

**(a) Animal Bedding – any material, except for baled straw, kept, offered or exposed for sale or sold for primary use as a medium for any companion or livestock animal to nest or eliminate waste.**

**(b) Expanded Volume – the volume of the product that can be recovered from the package by the consumer after it is unwrapped and uncompressed.**

##### **2.23.2 Method of Sale.**

---

<sup>15</sup> <http://www.nist.gov/pml/wmd/pubs/hb130-14.cfm>

**(a) Packaged animal bedding shall be advertised, labeled, offered and exposed for sale and sold on the basis of the Expanded Volume. If unit pricing is offered to retail consumers it shall be in terms of the price per liter.**

**(b) The quantity declaration shall include the terms “Expanded Volume” or wording of similar import that expresses the facts, and shall be in terms of the largest whole unit of the milliliter, liter, or cubic meter. A declaration may also include the quantity in terms of largest whole unit of cubic inches, cubic foot, or cubic yard only.**

**(c) The display of pre-compression volume, compressed volume, or supplementary dry measure units (e.g., dry quart, bushel) anywhere on the package is prohibited.**

**Examples: Expanded Volume 41 Liters (1.4 Cubic Feet)**

**Expanded Volume 1.4 Cubic Feet (41 Liters)**

**Expanded Volume 27.9 Liters (1700 Cubic Inches)**

**Expanded Volume 113 L (4 Cubic Feet)**

**Expanded Volume 8 Cubic Feet (226 L)**

**2.23.1.3. Exemption - Non-Consumer Packages of Animal Bedding Sold to Laboratory Animal Research Industry.** – Packaged Animal Bedding consisting of granular corncobs and other dry (8 % or less moisture), pelleted, and/or non-compressible Bedding materials that are sold to commercial (non-retail) end users in the laboratory animal research industry (government, medical, university, preclinical, pharmaceutical, research, biotech, and research institutions) may be sold on the basis of weight.

### **3. Technical Issues and Recommendations**

#### **a. A Test Procedure and New Designs of Test Measure for Use with Bedding are needed to Ensure Accurate and Repeatable Results.**

There is no test procedure for animal bedding in NIST Handbook 133 “Checking the Net Contents of Packaged Goods”<sup>16</sup> (NIST Handbook 133). When there is no test procedure for such a unique product, weights and measures officials must either develop new methods or modify existing ones for use.<sup>17</sup> Most weights and measures officials use the peat moss dimensional procedure (see Section 3.9. “Peat Moss”) to verify a declaration of compressed volume on bedding. They use the mulch test procedure and the volumetric measures designed for use in testing bags of mulch (see Section 3.10. “Mulch and

<sup>16</sup> <http://www.nist.gov/pml/wmd/pubs/hb133-15.cfm>

<sup>17</sup> The fact that test procedures for a specific product are absent from NIST Handbook 133 does not preclude the inspection of any package by weights and measures officials. That is because they have the authority to verify the quantity of any package sold by weight, measure or count as well as the duty to prevent fraud and unfair competition in the marketplace. Since there are literally thousands of products for which no specific test procedure will be found in NIST Handbook 133 officials are encouraged to contact NIST Office of Weights and Measures and other weights and measures colleagues for assistance when they encounter new or unique products.

Soils by Volume”) to verify uncompressed volume declarations. The mulch test procedure, like other volumetric methods, (such as those used in determining the weight-per-bushel for grain), require that the product be poured into a test measure from a consistent height, and there are strict limits on the handling of the product. Handling must be kept to a minimum because it reduces product volume. The way that bedding should be handled is significantly different from how pine bark and other mulches are handled when testing mulch because bedding has to be uncompressed or broken up before it can be tested. This has led to the practice of breaking the product up on a tarp and then placing the product into a test measure by hand. Packagers have concerns with this practice because they know from their testing experience at the point-of-pack that hand-filling reduces the volume delivered to the test measure, increasing the variability of tests. Another factor that contributes to the measurement uncertainty in testing bedding is the size of the packages, which can range from a few hundred cubic inches to more than 10 cu ft. Most states and packers only have test measures with capacities up to 3 cu ft so they have to take multiple measurements to test a 10 cu ft package. Because uncertainties associated with multiple readings of a single test measure are additive, the resulting measurement has a large uncertainty and may be only an approximation of the true volume contained in the package instead of one that is accurate and repeatable within reasonable limits.

**b. Reasonable Maximum Allowable Variations for both the compressed and expanded volume declarations must be developed in the near future or packages of Bedding should be exempted from the Individual Package Requirement in NIST Handbook 133<sup>18</sup>**

Ideally, the same test procedures and equipment specifications should be used by both packagers and weights and measures officials. This will allow for the collection of data that can be used to develop a reasonable MAV for bedding. Currently, the MAV Tables in NIST Handbook 133, Appendix A. (See Table 2-6. “Maximum Allowable Variations for Packages Labeled by Liquid and Dry Volume”) define an unreasonable package error as a package found to have a minus error greater than one percent (1 %) of the labeled quantity. In 2013 the NIST Office of Weights and Measures (OWM) reviewed limited data from inspections conducted in 2012 and 2013 by several states. This data revealed that most of the packages failed to meet the expanded volume declarations. In addition, the standard deviations found in the results were such that OWM recommended against enforcement of the 1 % percent MAV in Table 2-6, because the value appears to be unreasonable. Since these packages are required to bear two volume declarations, compressed and expanded, values for the MAV for both the compressed and expanded volumes will need to be quantified. (See discussion of the usefulness of the compressed quantity declaration elsewhere in this paper.) It is recommended, given the nature of the product, the uncertainty inherent in reading the test measures and other issues discussed in the following, more data from a wider range of bedding materials and package sizes will be needed before a final recommendation for a reasonable MAV can be proposed. However, based on current test results and anecdotal information and comments from several state officials who have tested a great deal of bedding, it is anticipated that an MAV of between 5 % to 10 % for tests where the volume of bedding is determined in a single measurement will ultimately be found to be reasonable. The tentative 5 % MAV recommendation would only be reasonable for a single measurement test. For example, if a 2 cu ft test measure is used to test a bag with an 8 cu ft expanded volume; four measurements are needed, so the MAV value must be at least doubled. For multiple measurements of volume for a single package, it is recommended that the tentative MAV be increased to 10 %. Note that previous data obtained using hand-filling cannot be combined with data obtained using the recommended test

---

<sup>18</sup> Currently the average error of a lot, shipment or delivery of bedding, where the sample size is 12 or fewer packages, must be at least equal to the labeled quantity and no individual package may have an unreasonable minus error (i.e., exceed the permitted Maximum Allowable Variation).

procedures to develop recommendations for the MAV values. If reasonable values for the MAVs cannot be developed in the near future, it is recommended that bedding be exempted from the Individual Package Requirement just as the NCWM has done with prepackaged firewood.

### c. Uniform Specifications for Test Measures of Appropriate Sizes for Packages of Bedding

It is known that industry and weights and measures officials use a variety of test measures, dimensional determinations, and volumetric procedures to verify the quantity declarations on packages of bedding. Because there are no specifications for test measures, officials typically use the measures specified in NIST Handbook 133 for testing packages of bark mulch. The dimensions of the mulch test measures were selected to replicate the package cross-section of bags of mulch that are sold in uncompressed quantities of 57 L (2 cu ft) or more. It is obvious that the cross-sections of bedding packages differ substantially from those of packages of mulch, and most bedding is compressed while bark mulch is not.

The maximum capacity of the mulch test measures is 2 cu ft or 3 cu ft.<sup>19</sup> When officials test large packages of bedding, they currently use multiple fills of the test measures to verify the quantity of an 8 cu ft, 10 cu ft, or 12 cu ft bag. Each of those individual measurements includes errors resulting from reading and rounding the results. When 4, 5, or 6 readings are combined, the measurement errors are added up, and the resulting action may be taken on faulty data. The Office of Weights and Measures recommends that multiple measurements of bedding be avoided whenever possible and a test measure of adequate size be used so that a single measurement can be made to determine the volume of bedding in a package.

To avoid the multiple-measurement issue, we constructed several large capacity test measures of square and cylindrical designs so that the volume of a package could be determined in a single measurement. The larger test measure designs also enlarge the area of the bottom of the column of product in the test measure. The larger area allows the height of the column to be reduced which reduces compression (see Exhibit 18). The OWM has developed specifications and some notes on test measure design and construction, which are presented in the following. Unlike mulch, where there are typically a few package sizes such as 56 L (2 cu ft) or 85 L (3 cu ft), bedding is sold (as mentioned above) in a variety of package sizes so test measures with a fixed volume marked on a scale with a few graduations above and below a set volume are impractical for use in testing bedding. For this reason, the OWM recommended designs for the test measures that are specific to bedding, and can be used to test most package sizes in a single measurement.

One reason for using the cylindrical design typically used for dry measures is that its shape reduces the occurrence of the voids frequently seen in the corners of square test measures. Voids in bedding cannot be completely avoided but with the cylindrical design their number is reduced so that they have less impact on the measurement result. The voids that appeared in the cylindrical measures in this study appeared less frequently than in square test measures. (See Exhibit 17 showing void in corner of square test measure.) As noted, the cylindrical design is preferred for dry measures as stated in NIST Handbook 44, “Specifications, Tolerances and Other Technical Requirements for Commercial Weighing and Measuring Devices,” Section 4.45. Dry Measures. A cylinder is one of the most structurally sound and strongest of the geometrical shapes. That strength derives from the geometrical shape which disperses stress throughout walls of the vessel. (See Exhibit 16 of the cylindrical and square test measures used in this study.) In addition, the surface area of a cylinder is smaller than the

<sup>19</sup> We understand that some packers (and at least one weights and measures jurisdiction) use a 1 cu ft test “struck” measure for volume measurements which further demonstrates the need for test measure specifications.

surface area of a square test measure of similar capacity so the volume can be determined with greater accuracy.



**Exhibit 20. Test Measures Used in Study.** The large test measures hold up to 279 L (10 cu ft) while the small measures hold up to 52 L (1.5 cu ft).



**Exhibit 21. Gap in Corner of Test Measure.**

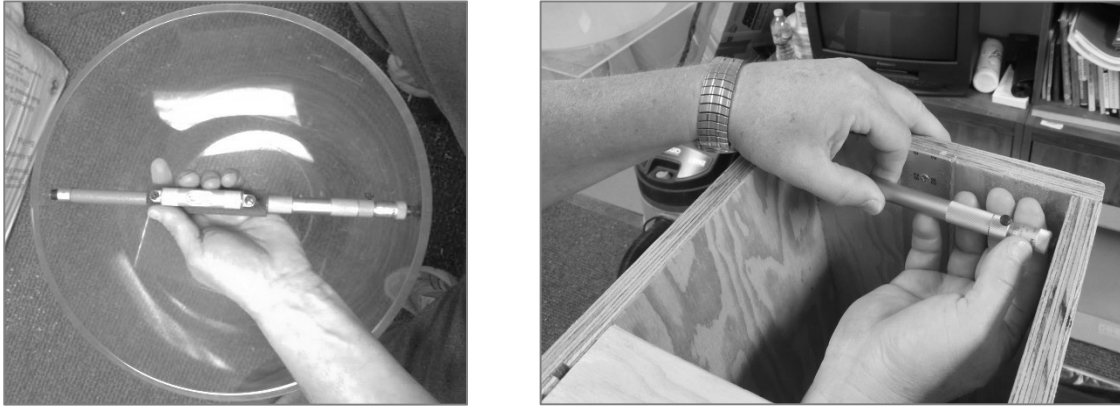

**Exhibit 22. Two Different Test Measures.** The test measure on the left contains 226 L (8 cu ft) of bedding while the test measure on the right contains 56 L (2 cu ft).

#### **d. Traceability of Measuring Instruments and Test Measures**

Another issue of concern is whether not the measurement standards (i.e., test measures and measuring instruments such as tape measures) used by officials and industry have been calibrated and that certificates have been issued indicating that they are traceable to national measurements standards. If untraceable measuring equipment is used in volumetric determinations, the data is questionable. When questionable measurements are involved there will be disagreements over test results and there is the

likelihood that packages will be misbranded.<sup>20</sup> To achieve uniformity and to ensure confidence in test data, all test measures, and measuring devices used by weights and measures officials and that are used in industry quantity control must be calibrated to be traceable to the SI. Calibrations can be provided by NIST recognized state metrology laboratories or other accredited facilities. (See pictures in Exhibit 19 of a calibrated internal diameter micrometer being used to verify the actual dimensions of the test measures used in this study.)



**Exhibit 23. Calibrated Internal Diameter Micrometer.**

#### **e. Hand Filling Reduces the Product Volume**

The standard test method for determining the weight per bushel of grain is determined using a cylindrical dry measure, which is filled using a pour method. This test method has been adapted in NIST Handbook 133 for determining the volume of Borax to verify the net weight of packages of that product. The accuracy and reliability of the pour method and the use of cylindrical dry measures is established, and it dates back to reports to the NCWM issued in 1913 and before.<sup>21</sup> A pour filling method is also used in testing mulch and some states use that method (after breaking up the compressed product) to test bedding, while other states use hand filling. Hand filling is used because the compressed product has to be broken up before placing it in a test measure. It is important to note that most of the packaging machines, which fill packages of bedding, have measurement chambers that are filled to a predetermined level with loose bedding using a “pouring” system, and then compressed into the package form and then wrapped. Thus, using a pour method to fill a test measure somewhat replicates the process followed in making the original volume measurement.

In this study we compared the volume obtained by pouring the bedding into a test measure to the volume obtained by hand filling the test measure. We found that hand-filling test measures consistently reduced

<sup>20</sup> Misbranding means overstating the net quantity of contents, misleads consumers, frustrates value comparisons, and is an unfair trade practice.

<sup>21</sup> See “Testing of Capacity Measures” by R.Y. Ferner, National Bureau of Standards on pages 181 - 200 in the Report of the 8<sup>th</sup> National Conference on Weights and Measures (1913). Cylindrical Test Measures: in addition to its strength which reduces the chance of deflection in the cylinder walls, another benefit of the cylindrical design is that it eliminates the 90 degree angles of the corners (where gaps in product fill frequently occur). Still another advantage of the design is that the surface area of a cylinder is less than that of an equal size square. It is the smaller surface area that improves the resolution in the volume measurements (i.e., using a 1.0 mm increment to compare the 0.37 L readability of a 24 in<sup>2</sup> square box with a surface area of 576 in<sup>2</sup>, to 0.27 L readability of a 24 in cylinder which has a surface area of 433 in<sup>2</sup>).

the volume obtained regardless of the type or size of the bedding (i.e., large and small flake). We also found that hand filling has a larger standard deviation than the pour method, which results in a larger uncertainty in test results. We verified the effect of hand-filling by first determining a specific volume of each product using a pour method and adjusting the volume. We then transferred the bedding to the test measure by hand. As shown in the following tables, we consistently found the resulting volume was substantially reduced. We then transferred the product into the test measure using a plastic lined chute and the pour filling method. We performed ten tests for each fill method and found the product volumes from the pouring tests were consistently higher than those found in the hand-filling method. We also found the standard deviations in the pour filling method were consistently lower than those found using the hand-filling method (see Tables 1, 2, and 3). It is important to note that at the end of the ten tests with hand filling we retested the bedding using the pour method and found that the volume of the product recovered close to the original amount.

**Table 1. 42 L – Large Flake Wood Product**

<b>Fill Method</b>	<b>Average Volume</b>	<b>Standard Deviation</b>
Hand	41.64 L	1.32
Pour	42.14 L	0.17

**Table 2. 35 L – Small Flake Wood Product**

<b>Fill Method</b>	<b>Average Volume</b>	<b>Standard Deviation</b>
Hand	33.69 L	0.22
Pour	35.05 L	0.19

**Table 3. 38 L – Shredded Paper**

<b>Fill Method</b>	<b>Average Volume</b>	<b>Standard Deviation</b>
Hand	38.35 L	0.97
Pour	38.78 L	0.36

**Exhibit 24.** Photo to the right shows the use of a chute to pour small flake bedding into a 283 L (10 cu ft) test measure.



**Exhibit 25.** Photo to the left shows the use of a chute to pour shredded paper bedding into a 44 L (1.5 cu ft) test measure.

Even though we found the repeatability of pour filled tests to be significantly better than hand filling, more testing will be needed to confirm that the results are reproducible with all types of bedding.

#### **f. The Pour Filling Method aids in the Recovery of Product Volume**

More than 100 measurements were made using the pour filling method pictured above and it was found that the volume quantities obtained on second pour were generally greater than those obtained during the first pour. The increase in volume found on the second pour was common with most products and makes sense after examining the packaging process. The compression bagging machines are designed to compress product in different ratios but in one example the product is compressed in a ratio of 5 to 1 using up to 1000 or more pounds per square inch of pressure (i.e., 10 cu ft of loose bedding is compressed to 2 cu ft). Even though the test procedure calls for compressed product to be “uncompressed” by hand, that process in itself does not appear to be sufficient to completely loosen the product on its own. The pouring aids in uncompressing the product and allows it to recover more of its original pre-compression volume. The findings indicate that the volumetric test procedure should require at least two pours for each package with the expanded volume being determined on the second pour. The graph below illustrates the findings on a sample of six packages of small pet bedding of shredded paper. The results illustrate (the first pour volume is illustrated by the dark column and the second pour volume is illustrated by the lightly shaded column) how the product volume typically, but not always (see package 4, which also happened to be the lightest weight package in the sample), increases on the second pour. Some of the differences between the first and second pour were 2 L (122 cu in or 7%) or more. We found similar increases of volume with all other products, further supporting the suggested requirement for at least two pours before the volume is determined.



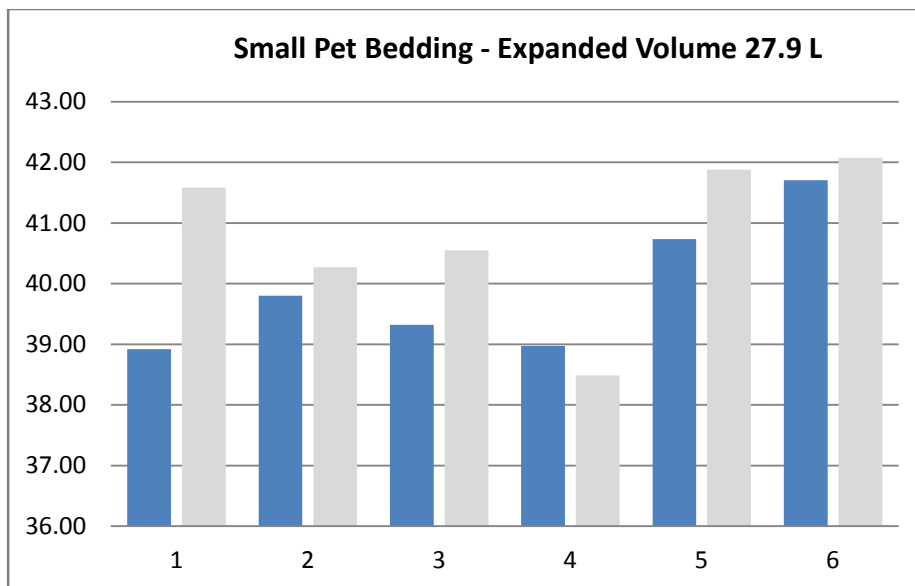

**g. Chutes – Used for Uncompressing Bedding and Pouring into the Test Measure**

Because the compressed bedding must be uncompressed by hand before it can be poured into a test measure, it was decided that a tray or chute of adequate size could be used for both purposes. When experimenting with plain cardboard chutes, it was found that the bedding would not flow into the test measures evenly and without a lot of shaking. Cardboard chutes were then lined with polyethylene sheeting creating a smooth slippery surface that allowed the bedding to flow freely and evenly into the test measure. The latest generation of the chutes was constructed of wood in various dimensions to hold the expanded volume of various size packages of bedding. Constructed of  $\frac{1}{4}$  inch plywood, they are lined with thick poly sheeting to ensure the product flows out smoothly. In Exhibit 22 upper left picture, a 280 L (10 cu ft) chute is being used to uncompress the bedding. In the picture on the right the bedding has been uncompressed and is ready to be poured into the test measure. The pictures on the next page show how the bedding is uncompressed in a chute by hand. The last picture shows the four sizes of chutes used in this study.

**Exhibit 26.** These pictures show a package of bedding being opened and the product being uncompressed and prepared for measuring.





**Exhibit 27.** The following pictures show how a larger chute (over 280 L) and smaller chutes are used to fill the test measures.



The specifications for the chutes corresponding to typical size packages of bedding are shown below and will be included in the equipment list for the expanded volume test procedure.

<b>Chute Specifications</b>			
<b>Chute Nominal Capacity</b>	<b>Height</b>	<b>Width</b>	<b>Length</b>
70 L (2.5 ft <sup>3</sup> )	254 mm (10 in)	228 mm (9 in)	1219 mm (48 in)
100 L (3.5 ft <sup>3</sup> )	254 mm (10 in)	279 mm (11 in)	1397 mm (55 in)
170 L (6 ft <sup>3</sup> )	279 mm (11 in)	355 mm (14 in)	1727 mm (68 in)
240 L (8.5 ft <sup>3</sup> )	304 mm (12 in)	406 mm (16 in)	2006 mm (79 in)
283 L (10 ft <sup>3</sup> )	304 mm (12 in)	406 mm (16 in)	2286 mm (90 in)

**NOTES:** The chutes are constructed using hinges and pins so that they can lay flat for transportation. They can be constructed of sheet metal or other slick surface material which enable the bedding to flow easily. The construction of the chutes used in this study allows the sides to move in or out slightly so that the bedding does not become clogged at the outlet. The heights and lengths may be adjusted slightly to fit into vehicles for transport but the widths should not be reduced because narrowing the opening can restrict material flow. Also, the width should be kept smaller than the opening of the test measure so that spillage does not occur during pouring.

#### **h. Calculating the Volume of Bedding in a Test Measure Using a Headspace Method**

##### **i. Hand Leveling of the Bedding causes “Packing” and Reduces Volume**

Whenever dry measures are used, NIST Handbook 133 cautions inspectors that measures should be filled “without agitating” (Section 2.4. “Borax”), or that the inspector should “not rock, shake, drop, rotate, or tamp the test measure” (Section 3.10. “Mulch”). This study was conducted following the handbook’s guidance and the test measures were filled using the pour method. Following the instructions in Section 3.10. “Mulch,” care was exercised “in leveling the surface” of the bedding so that visual readings could be taken across the top surface of the bedding to determine the volume. In Exhibit 25 below, a level is being used to check for level. For this study multiple measurements were taken (e.g., 4 to 12 readings which were averaged) of the height of the bedding inside the test measures. One of the advantages of using the transparent test measures was that the amount of “packing” that was taking place inside the test measure could be seen and measured as the surface of the product was leveled. The term “packing” is used here to clearly distinguish the unintentional, but unavoidable, reduction of volume that results from the act of hand-leveling the bedding. This seems to be a reasonable distinction to make since some level of compression of all of the bedding types tested occurred, and cannot be eliminated. However, larger surface areas of the recommended test measure designs reduce the height of the column in the measure substantially, which in turn will reduce the amount of compression that occurs during testing.



**Exhibit 28. Leveling the Surface. Showing the use of a 150 mm mesh to level the surface of large flake bedding.**



**Exhibit 29. Checking Level. Checking the surface of large flake bedding for an approximation of a level condition.**

The impact of “packing” was first observed when leveling out a test measure filled with small flake bedding. It was determined that using hands to level the product would not result in consistent results between inspectors. A 150 mm piece of rigid stainless steel mesh was then used to level the product. However, even when all three testers used the same mesh to level the small flake bedding, there were wide variations over the surface of the product as well as a reduction in volume. Samples of large flake and cellulose bedding were tested and it was found that “packing” occurred with those products.

It should be noted that measurements were made in millimeters because that size increment is easily readable in field situations and it simplifies the calculations. “Packing” is a concern because a 1.0 mm change in height of the bedding has a significant impact on the resulting volume in any test measure (the errors vary depending on the surface area of the test measure). For the 63.7 L (2 cu ft) wooden test measure used for measuring mulch, a 1.0 mm error in a height measurement will result in an error of 92 mL (5.6 cu in) while a 1.0 mm error in a 283 L (10 cu ft) square wooden test measure recommended for use in testing bedding will result in a volume error of 0.37 L (22.6 cu in). On the other hand, due to its smaller surface area, a 1.0 mm error in measurement in the 279 L (9.8 cu ft) cylindrical measure is equivalent to 0.27 L (16.4 cu in).

To find a way to address the issue of the “packing” caused by hand leveling, the bedding was repoured into the test measure and, without leveling the product, the headspace measurement procedure was used as described in the following Item ii. “Headspace Measurement Procedure Adapted for Bedding.” Twenty-six measurements were taken across the surface area of the bedding to determine its volume. Those values were averaged and subtracted from the height of the test measure to ascertain the volume as illustrated in Figure 1. The bedding was then leveled with the 150 mm wire mesh and another 26 measurements were taken across the surface to determine the volume. The differences were significant and verified that leveling the product by hand reduced the volume. The volume, after leveling on the smaller test measures, ranged from 0.2 L to 0.5 L less than the unleveled volume and up to 5 L less than the unleveled volume on the larger test

measures. Because these significant differences were discovered early in this study no further leveling of the bedding was done, and the headspace method was used for all subsequent volume determinations. It was found, after a little practice, the measurements were easily made and the improvements in accuracy were well worth the added effort.

**ii. Headspace Measurement Procedure Adapted for Bedding**

Testing any product (from grain to Borax) using a dry measure can be fraught with opportunities for measurement errors from “packing” when the product is leveled.<sup>22</sup> Measurements were taken inside the test measure rather than around the outside of the test measure. This allowed more accurate measurements to be made directly on the product so that the variations in the surface (which cannot be eliminated) could be “smoothed” out by averaging multiple measurements. This headspace method is used in NIST Handbook 133 for determining the volume of paint in a can and is described in Section 3.7. “Volumetric Test Procedure for Paint, Varnish, and Lacquers.” In that procedure the volume is determined by measuring from the bottom of a spanner bar down to the surface of the liquid and this value is subtracted from the interior height of the can to obtain a height measurement, which can then be used to calculate the volume of the paint. The surface of a liquid is level so only three measurements are taken and averaged. Because the surface of bedding is very irregular, a greater number of measurements must be taken in a uniform pattern across the surface of the bedding to obtain a representative depth from the top of the test measure. By taking at least 25 measurements spaced across the surface area of the square or cylindrical measures, good results were obtained with a good representation of the average depth. The follow graphics illustrate how the headspace method works:

---

<sup>22</sup> See page 191 in “Testing of Capacity Measures” by R.Y. Ferner, National Bureau of Standards on pages 181 - 200 in the Report of the 8<sup>th</sup> National Conference on Weights and Measures for 1913 for an earlier discussion of the “packing” effect.”



**Picture 1.** This picture shows how to read the depth of container.

The picture on the left (Picture 1) shows how to read the depth from the bottom of the straightedge (top edge of measure) down to the bedding in a 44 L test measure from a position that reduces parallax. Picture 2 below illustrates the actual worksheet with the headspace procedure on the 44 L cylinder test measure (its internal radius is 151 mm and its height is 610 mm). The bedding was poured into the test measure but not leveled. Then 26 measurements were made at the locations shown on the grid to determine the depth of the product from the top edge of the measure. The average of the 26 values was 500.7 mm which was subtracted from the height of the test measure to obtain 109.26 mm for the average height of the column of bedding in the measure.

The volume was calculated using:  $Volume\ in\ liters = \pi r^2 h$   
 $3.14159265 \times 23035.69 \times 109.26\ mm = 7.90\ L^*$

\*After the calculation was completed, the result was divided by 1 000 000 to obtain the volume in liters.

**Figure 6.** Illustration of Worksheet.

	413	367	390	
439	439	430	419	432
478	475	492	462	478
552	542	528	532	530
578	580	577	569	565
	589	590	573	



**Figure 3.** Using the headspace measurement on a 279 L test measure. The ruler is read from the bottom edge of a straight edge or level from a position that reduces parallax.



**Figure 4.** Showing how the ruler is placed on the bedding with the headspace method. The ruler is read from the bottom edge of a straight edge or level from a position that reduces parallax.

Some packers may choose to level the product in a test measure or take fewer readings across the surface to determine if the package passes or fails a quantity control test in a production environment. But, in official inspections by weights and measures officials, it is recommended that the product be poured into the test measure and measured without leveling so that the “packing” (volume reduction) that is known to occur whenever the product is handled can be avoided. Also, for official tests, it is critical that variations be measured so the data can be utilized in the calculations of sample standard deviations and sample error limits to decide if a sample passes or fails.

#### **i. Optional Audit Screening by Weight**

The verification of the expanded volume of animal bedding outside of a production plant requires the inspector to destroy the package and un-compress the product. After the product is tested, it cannot be returned to the original packaging so it will need to be discarded or placed in a large trash bag to be held for disposition by the retail store. In carrying out this study, the packages were weighed prior to opening them for the volumetric test to see if there was a consistent relationship between weight and volume. In reviewing the test data, it was found that the net weight of the packages did not correlate with the expanded volume found in testing. However, it was determined that the package gross weights could be used in an audit procedure. For example, if the expanded volumes of the lightest and heaviest packages in a sample passed, it could be expected that all of the remaining packages in the sample would also contain at least the expanded volume. The Industry experts we spoke with agreed that this type of weight screening was workable could be used to save both time and labor expenses and also reduce destructive testing and product waste.

To see if a weight screening approach would work in the real world, two sets of samples comprised of six packages from two different lots of a bedding product made of cellulose were collected. The expanded volume declared for both samples was 27.9 L (1700 cu in). All of the packages in each sample were weighed to obtain their gross weights and then each was tested to verify the expanded volume. The results from both samples revealed that the expanded volumes of the four intermediate weight packages fell well within the range in volume between the lightest and heaviest packages in the sample (the gross weights of each bag are shown on the bars of the graphs).



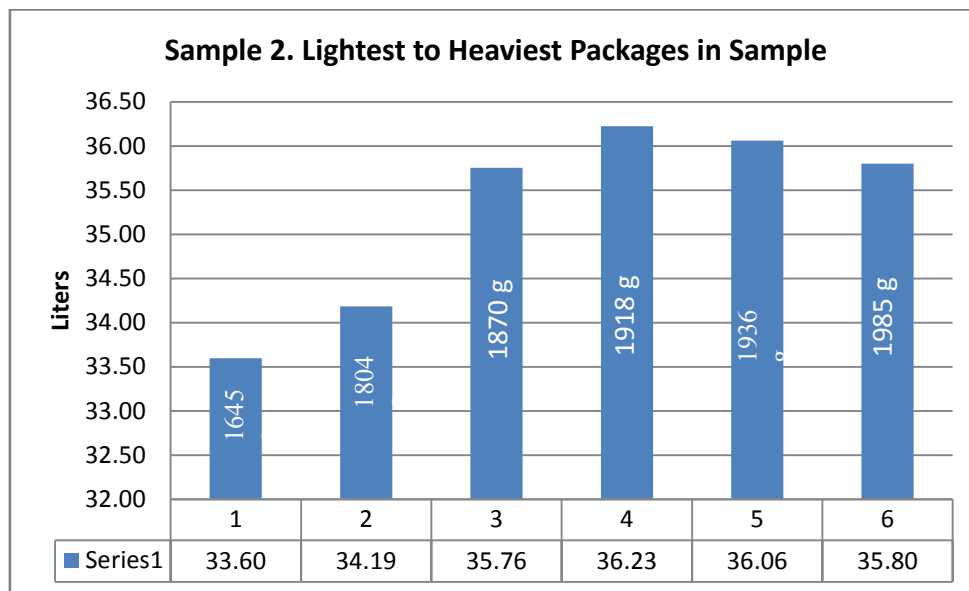
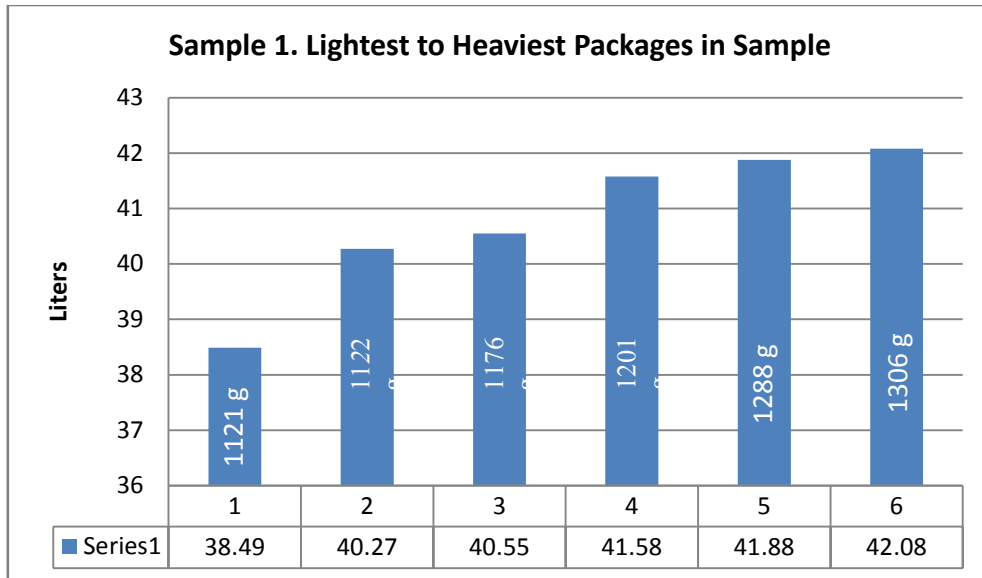

Regardless of the type of product under test, the volumetric test destroys the packaging and the product cannot be repackaged. This is a suggested alternative approach to reduce destructive testing and to save inspection resources. The test procedure will contain the recommendation that after randomly selecting the sample packages from the inspection lot, a gross weight be taken on all, select the lightest and heaviest packages first, and conduct a volumetric test on them to verify the expanded volume. If the lightest and heaviest packages pass the volumetric test, it is likely that the remaining packages in the sample will also pass. Jurisdictions may want to accept the sample as an AUDIT TEST and inspect another lot. If either of the two packages are found to have a minus error that exceeds the MAV the sample fails and no further testing should be done (assuming 0 MAVs are allowed for the sample size (see NIST Handbook 133, Appendix A, Table 2-1. “Sampling Plans for Category A”). However, if either of the first two packages has a minus error that does not exceed the MAV the inspector should test all of the packages in the sample as they normally would in a NIST Handbook 133 test procedure.

If the gravimetric audit procedure is used, the inspector will be advised to ensure that the scale is sitting on a solid level support and that its accuracy has been verified to a test load that is at least 10 % more than the gross weight of one of the packages (e.g., to estimate that value place one of the packages on the scale and then test the scale with a load above the package's gross weight).

**j. There is Little Benefit for Consumers in Verifying the Compressed Quantity Declaration**

Based on a review of test data provided by states from the 2012 - 2013 testing, it is noted that in most instances the fact that a package passed the compressed dimensional test did not ensure that the package would pass the uncompressed volume test. Test findings for the compressed and uncompressed quantities in this study were consistent with the state results. Furthermore, in the opinion of industry experts, even if the compressed quantity is correct that does not mean that the expanded (uncompressed) volume declaration will be accurate.

It is unlikely that most packages of animal bedding would fail the dimensional test. If the sample packages do not measure up, the Inspection Lot should be rejected without further testing. However, if should a sample passes the dimensional test, the volumetric test must be carried out before a final decision on whether or not the lot passes both tests is made.

**4. Packages of Compressed Bedding**

**a. How Manufacturers determine a Compressed Volume Declaration.**

A compressed volume declaration on a package of bedding is determined from the target dimensions of the finished goods package as designed. Manufacturers design these packages as cuboids with all right angles and flat surfaces. Typically, the natural variability of the fibers they package will almost always create some “plumping” along the surfaces and rounding on the edges resulting in irregular package dimensions. For most manufacturers the target compressed volume design intentionally errs on the side of a smaller compressed volume declaration than could be reasonably claimed, but that approach ensures compliance with the stated compressed volume (assuming the package is adequately filled). Because packers tend to understate the compressed volume declaration, these products routinely pass the compressed package (peat moss) test procedure in NIST Handbook 133.

**b. A Dimensional Test is used to Verify Compressed Volume.**

This method of determining the volume has a large uncertainty. This is due to the difficulty in obtaining exact measurements of irregularly shaped packages in flexible packaging. Typically bedding packages (like peat moss) are formed in a rectangular cuboid, but the edges of most bags are rounded and there is expansion (or “plumping”) of the panels of a bag (including the ends and sides). Some packages of compressed bedding are irregular in shape and so loosely packed such that they do not hold a cuboid form firmly enough for reproducible measurements to be made. Exhibit 26 on the left shows a package of peat moss, which is the product that the original test procedure was developed to verify. Exhibit 27 on the right is a package of “compressed” bedding that is too loosely packed to utilize the peat moss dimension procedure.



Exhibit 30. Peat Moss.



Exhibit 31. Compressed Bedding.

**Note:** For the purpose of providing uniform identity of the dimensions recorded for this study, a cuboid is shown in Exhibit 28 with the dimensions identified and oriented with the Principal Display Panel (PDP) as it is defined in the NIST Handbook 130, “Uniform Packaging and Labeling Regulation.”

Exhibit 32. Determining the Volume of a Cuboid.

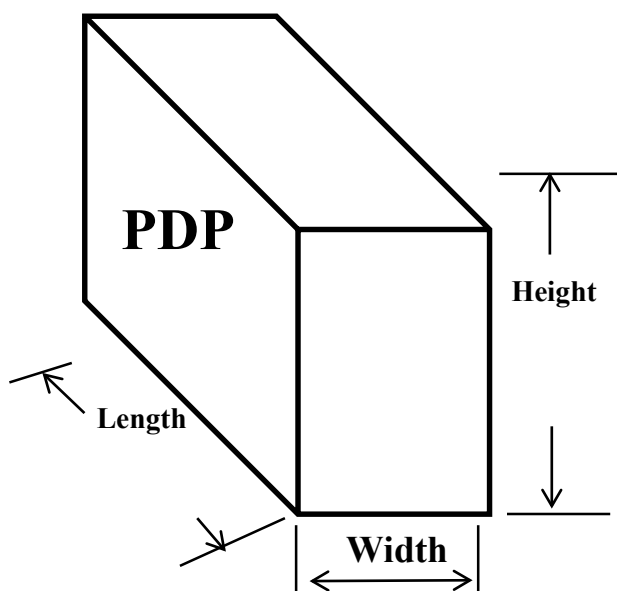

The formula for determining the volume of a cuboid<sup>23</sup> is  $Volume = Length \times Width \times Height$  (Note: an alternative formula  $Volume = Height \times Area\ of\ the\ Base$  (where  $L \times W$  give the area of the base). In the case of packages of bedding, this formula may not provide an accurate determination of volume. This is because the geometric formula for a cuboid is based on the 6 panels of the cuboid being flat and the 12 edges meeting at 90 degree right angles. On most compressed bedding, the package edges are rounded and there can be “plumping” or depressions in the package panels (excess packaging tails<sup>24</sup>

<sup>23</sup> A cuboid has six rectangle faces, twelve edges and eight vertices. It is also called a right cuboid because the edges meet at right angles of exactly 90 degrees.

<sup>24</sup> A packaging “tail” is that part of the flexible packaging remaining after the package is heat sealed and cut.

can also cause errors) making it difficult to visually define a measurement point. The following picture shows the rounded edge of a 16 L package of red cedar bedding. The “plumping” of the package and rounded edges (angles) make it difficult to define a measurement point for the length, width, and height of the package.



**Exhibit 33. Plumped bedding package illustrating rounded edges (angles), which hinders getting accurate measurement points.**

A packaging “tail” is the part of the packaging remaining after the package is heat sealed and cut. Typically, tails are found only on the top or bottom of the package and can be avoided in taking the length and width measurements along one side of the package. As shown in the photographs in Exhibit 32 the size of a “tail” can vary greatly from product to product. If, for some reason, they cannot be avoided for the dimensional test, they must be folded consistent with the packaging design and taped against the body of the package to provide a clear field of view and placement of measuring equipment during the dimensional test.



**Package Tails:** The “tail” on the package shown at right was folded and taped so that dimensional measurements of height could be made. The thickness of single layer of this wrapper was 0.0035 in. At several measurement points on one end of this package there were seven layers (0.024 in) of packaging. In addition, the “tail” on the other end of the package totaled three layers (0.010 in). The total thickness for both ends was 0.034 in. In NIST Handbook 44, “Specifications, Tolerances and other Technical Requirements for Commercial Weighing and Measuring Devices,” Section 5.52. “Linear Measures” the Acceptance Tolerance for a 36 in ruler is  $\pm 0.046$  in. In this example, the error caused by not deducting for the thickness of the packaging equaled at least 70 % of the tolerance allowed for a 36 in ruler.



Unlike the ASTM International test method for peat,<sup>25</sup> NIST Handbook 133 does not require adjustment of the net volume to reduce measurements to account for the thickness of the packaging (e.g., on a 3 mil thick package [0.003 in], each measurement would be reduced by twice the bag thickness or (0.006 in) which benefits packers). (See the discussion in the table above for an example of how the packaging thickness with multiple thicknesses relates to the tolerance for the measuring device.) By not deducting for the thickness of the packaging, the calculated volume is increased to the benefit of the packer.

NIST Handbook 133 requires the measurements to represent the dimensions of the cuboid of the bedding so the inspector must ensure that tails are folded and measurement points taken such that multiple folds of packaging material do not affect the accuracy of the measurements. The following pictures (Exhibit 32) show the edges from 16 L (1000 cu in), 85 L (3 cu ft) and 113 L (4 cu ft) packages of mini and large flake bedding showing how rounded “angles” make it difficult to define a measurement point for the length, width, and height of the package.



<sup>25</sup> See Section 6.2 of ASTM International D2978-03 (Reapproved 2010) “Standard Test Method for Volume of Processed Peat Materials.”

**Exhibit 35. Measurement Technique.**

The radius of the edges of the packages tested with quantities of 16 L to 156 L ranged from about  $\frac{3}{16}$  in to more than 2.5 in. The following graphics illustrate how the radius impacts the accuracy of the area determination. The area of the colored rectangle with 90 degree angles shown below is 96 sq in.

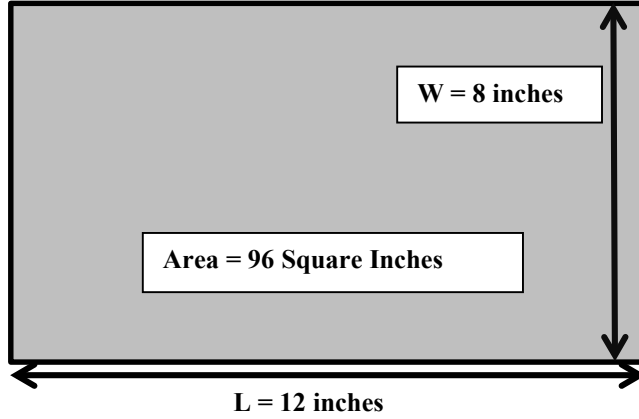

**Exhibit 36. Graphics illustrating impacts the accuracy of the area.**

If this rectangle is redrawn with rounded corners the area will decrease as the radius increases.

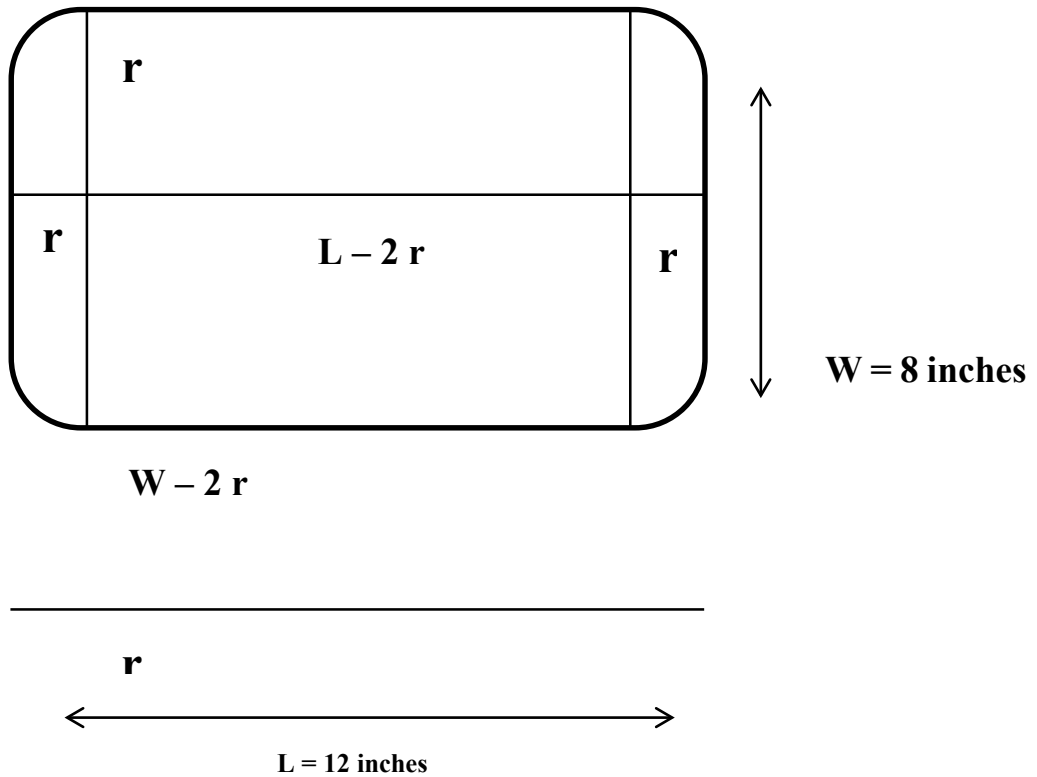

**Exhibit 37. The impact of rounded corners on determining the accuracy of**

This table illustrates how rounded corners impact the accuracy of a volume determination. The comparison of radius measurements show how the cuboid volume differs from the actual volume of the package from 1 cu in to 86 cu in as the radius of the corners increases.

Radius (r) of Corners in Inches	Length	Width	Height	Volume with Rounded Corners $H \times (L \times W - (4 - 3.14159265) r^2)$ Volume in Cubic Inches	Cuboid Volume $L \times W \times H$	Difference from Cuboid in Cubic Inches
	in Inches					
$\frac{3}{16}$	12	8	16	1535.5	1536 cu in	- 0.5
0.25				1535		- 1.0
0.5				1532		- 4.0
1.0				1522		- 14.0
2.5				1450		- 86.0

### c. Product Variations Are Common in Other Dimensional Tests in NIST Handbook 133

It is important to remember that dimensional testing is used for other packaged goods in NIST Handbook 133 such as bundled and boxed firewood as well as polyethylene sheeting and even paint. Similar measurement challenges are encountered in defining the measurement point and in accounting for irregular shapes. However, bedding can be distinguished from packages of firewood because packages of bedding are required to bear declarations of the quantity in terms of the usable (expanded) volume which can be verified in a test measure.

### Average of Multiple Measurements

One approach that NIST Handbook 133 uses to deal with variations in product sizes is to take multiple measurements along each panel and then average the results. The assumption for this approach is that the greater the number of measurements taken, the better the average value reflects the actual dimensions of the product under test. Because the shapes of bedding packages vary significantly, additional measurements improve the accuracy of the measurements. For the test procedure recommended NIST is advises that at least five measurements be taken for each dimension being verified (i.e., length, width, and height) and that these values be averaged.

## 5. Errors

### a. Observational Error

For this test procedure a linear measurement is understood to be the distance between two points in a straight plane, that is a reference (or zero) point and a measurement point. There are many possibilities for error in testing packages dimensionally. One of the most difficult issues with bedding packages is identifying measurement points due to the irregular surfaces of the planes (e.g., plumping of the package). Several recommendations are provided below that may help reduce measurement errors and uncertainty. Some basic measurement issues which are problematic in most measuring processes will be reviewed so that every reader has an understanding of the factors that were considered in developing these test procedures.

**i. Parallax**

When the graduations are too far from the measurement point, such as when a thick ruler is used, there is a possibility that measurement errors will occur as a result of parallax. Parallax is the apparent displacement of a graduation due to a slight change in the position of the observer. This is illustrated in the exaggerated graphic on the left.

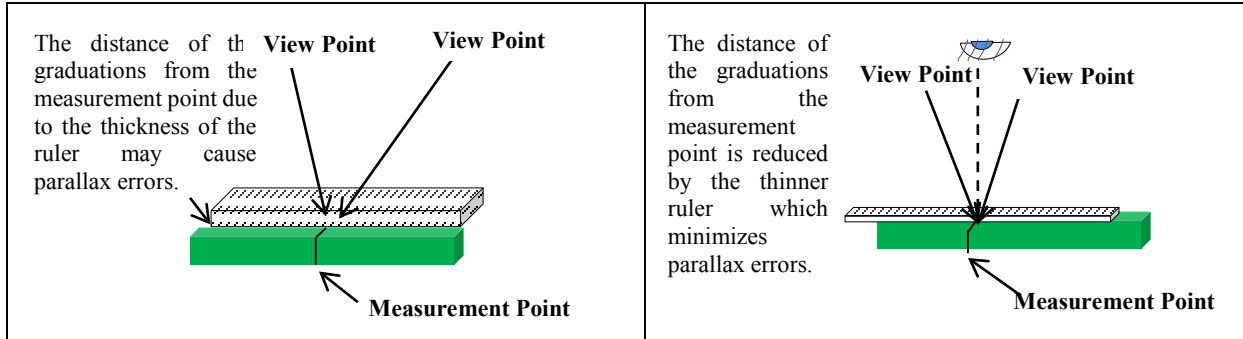

One way to reduce parallax error is to use a thin ruler and place it so that its graduations are as close to the measurement point as possible. By understanding parallax you can usually reduce it to a minimum by using suitable test equipment and aligning your eyes so that they are perpendicular to the graduation (see dashed line) and the measurement point. See graphic above right.

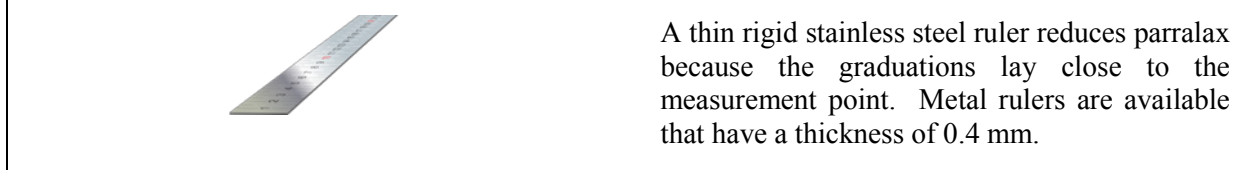
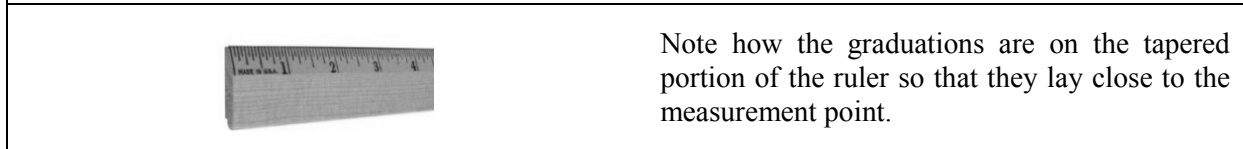

A rigid tape measure can also cause parallax errors. This is because the curve in the blade (which strengthens the tape) will hold the markings up off the package being measured by as much as 9/32 in or more on a 1 in wide tape. To eliminate this problem the inspector must push the tape flat against the package. See picture at right.

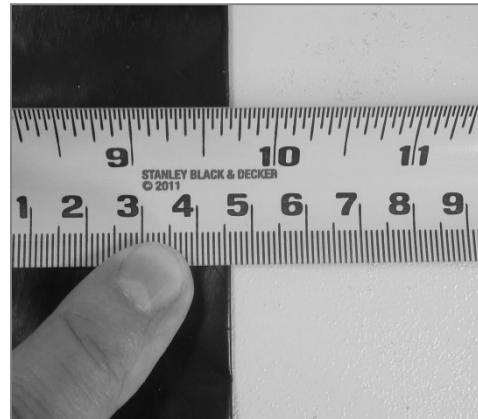
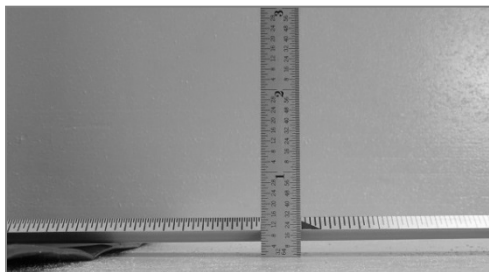

This publication is available free of charge from: <https://doi.org/10.6028/NIST.SP.1210>



## b. Manipulative Errors

### i. Bending a Tape or Using Improper Angles on a Ruler or Tape will Result in Measurement Errors

For this test procedure a linear measurement is considered the distance between two points in a straight plane. When a linear measuring device is used, it is important that the measuring instrument not bend or “deflect” because any measurement taken that is not parallel to the edge of the package (i.e., the straight plane mentioned before) will introduce trigonometric errors (these are typically cumulative). This is one reason that flexible tapes are not recommended for use in this NIST Handbook 133 test procedure. As mentioned above, most tape measures have a curve in the blade to stiffen it. Because tapes are flexible, it is essential that the inspector reduce the deflection to a minimum before taking a reading of any measurement. Another source of error is the angle of the measurement. Always keep a 90-degree angle to the edges of the package to avoid introducing errors (see photos exaggerated examples.)



Do not bend the tape.



Wrong! Keep the angle of the tape or ruler perpendicular to the edges of the package or trigonometric errors will occur.

**Exhibit 38. Proper Measurements are required to avoid errors.**

### ii. Rounding

Another source of error occurs when the measurement point falls halfway between two graduations on a ruler. Here the error can be as much as half the graduation. For example, if you use a ruler with  $1/16$  in (1.58 mm) graduations, the potential rounding error is  $1/32$  in (0.75 mm) or more. To avoid disputes over the possibility of subjective judgments, the draft procedure requires rounding of measurements that fall between two graduations up in favor of the packer as a matter of practice. The use of millimeters will help to further reduce the errors in volumetric determinations and will simplify the calculations as well.

### iii. Slippage

It is difficult to keep the zero “reference point” stabilized when you are measuring any object free handed. Packages of bedding are much more difficult to measure because of their irregular shapes. When measuring most items, you place the zero of the ruler at one edge of the object and then move your head to read the ruler at the measurement point. Experts in dimensional measurement have found that when the observer moves their head from the reference point to view the measurement

point they frequently move their hands apart and lose the zero reference.<sup>26</sup> See Exhibit 35. This draft procedure recommends that at least 5 measurements be taken to determine the length, width, and height of a package so there will be a potential for 15 instances of slippage, which can have significant impact on the accuracy of the volume determination. Several inspectors who recognize the problem of slippage and who routinely test bedding reported that they use a clipboard or place the package against a wall to provide a solid base for the zero reference. Using that concept, an inexpensive but rigidly constructed three-sided “Measurement Frame” was built to aid in keeping the reference point stable against a solid surface to improve the accuracy of the measurements. See Exhibit 36.



**Exhibit 39. Taking Measurement Points.**

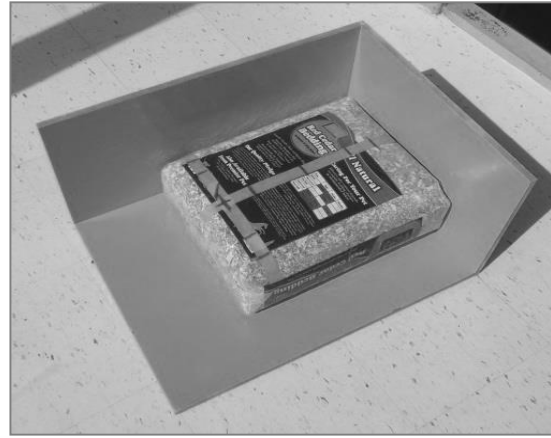
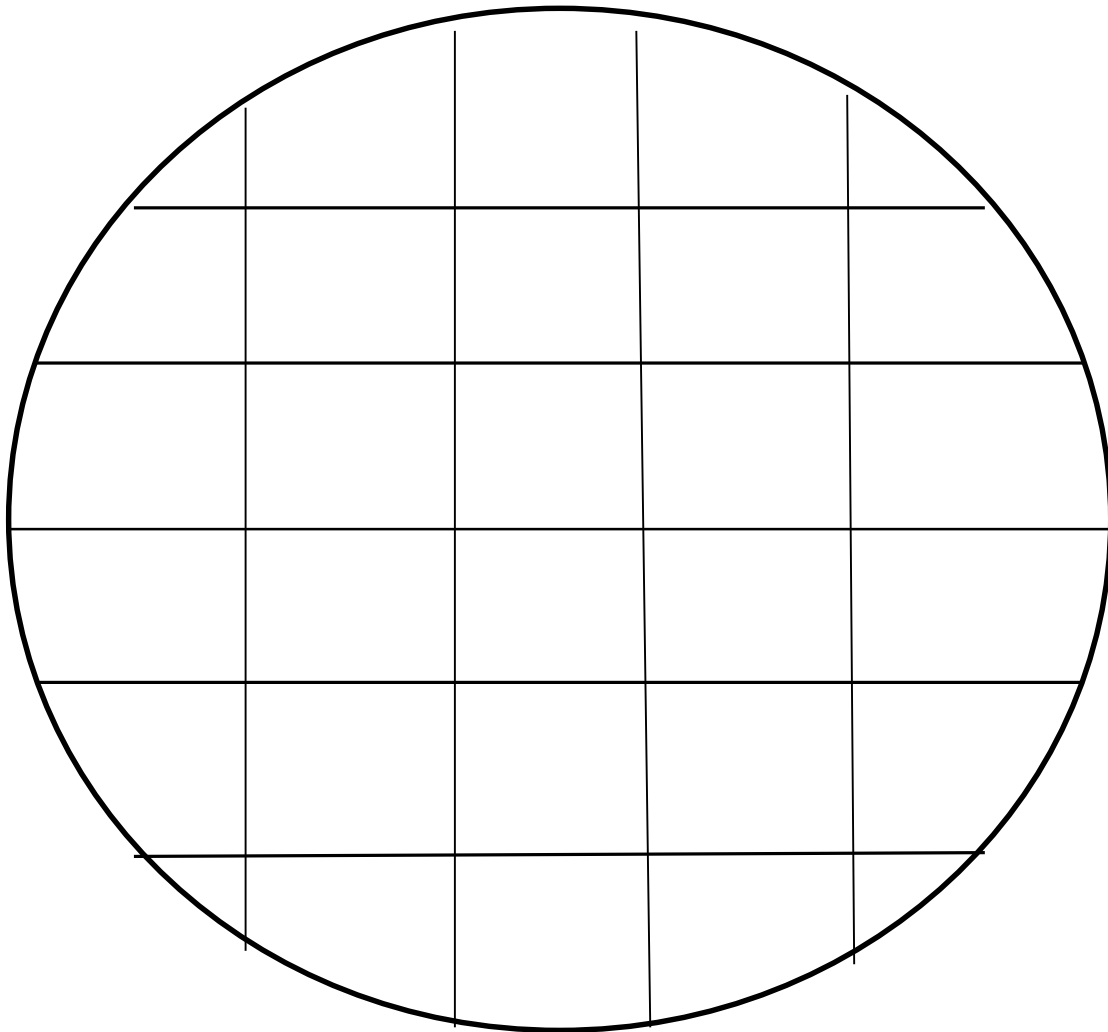

**Exhibit 40. Measurement Frame built as an aid to keep reference point stable.**

Another step to improve the process is the use of a carpenter square or straight edge to help define the measurement point. The square or straight edge is moved to five points along the package to allow the inspector to make measurements of variations in the dimension. By combining the use of the measurement frame, a rigid rule with 1.0 mm graduations and the carpenter square or straight edge, the accuracy and reproducibility of the measurements (and so the compressed volume measurement) are improved substantially.

<sup>26</sup> See Chapter 5, “Measurement with Graduated Scales and Scaled Instruments in “Fundamentals of Dimensional Metrology” for additional information on good measurement practices.

## Appendix A. 26 Point Measurement Grid and Package Error Worksheet for Cylindrical Test Measures



Sample Package \_\_\_\_\_ Labeled Expanded Volume (L): \_\_\_\_\_

A. Interior Height of Test Measure: \_\_\_\_\_ B. Radius of Test Measure (r): \_\_\_\_\_

C. Average Depth (Sum of Measurements ÷ 26): \_\_\_\_\_

D. Average Height of Bedding (= A - C): \_\_\_\_\_

E. Volume (L): \_\_\_\_\_ =  $3.14159265 \times r^2 (B^2)$ : \_\_\_\_\_  $\times$  D: \_\_\_\_\_  $\div$  1 000 000

F. Package Error (L): \_\_\_\_\_ = Labeled Volume (L): \_\_\_\_\_ - E (L): \_\_\_\_\_

Volume is calculated using: *Volume in liters =  $\pi r^2 h$*  For example: if  $r^2$  is 23035 and height of bedding is 109.26 then  
 $((\text{Pi}) 3.14159265 \times r^2 (23035) \times 109.26) \div 1\,000\,000 = 7.90 \text{ L}$

## Appendix B. 25 Point Measurement Grid and Package Error Worksheet for Square or Rectangular Test Measures

This publication is available free of charge from: <https://doi.org/10.6028/NIST.SP.1210>

Sample Package \_\_\_\_\_ Labeled Expanded Volume (L): \_\_\_\_\_

A. Interior Height of Test Measure: \_\_\_\_\_ B. Area of Test Measure Base (L× W): \_\_\_\_\_

C. Average Depth (Sum of Measurements ÷ 25): \_\_\_\_\_

D. Average Height of Bedding (= A – C): \_\_\_\_\_

E. Volume (L): \_\_\_\_\_ = B. Area of Test Measure Base: \_\_\_\_\_ × D: \_\_\_\_\_ ÷ 1 000 000

F. Package Error (L): \_\_\_\_\_ = Labeled Volume (L): \_\_\_\_\_ – E (L): \_\_\_\_\_

Volume is calculated using: *Volume in liters = (lw)h* For example: If length and width are 609.6 the area of the measure's base is 371612. If the Average Height of the Bedding is 109.26 then:

B. Area of Test Measure Base (371612) × Average Height of Bedding (109.26) ÷ 1 000 000 = 40.6 L

This publication is available free of charge from: <https://doi.org/10.6028/NIST.SP.1210>

<b>Date:</b>	<b>NIST Handbook 133 - Category A</b> <b>Worksheet for Packages of Animal Bedding and Peat Moss Labeled by Volume – Dimensional Procedure</b> Lot Size _____ Sample Size _____											
<b>Labeled Quantity</b>	<b>Converted to Fluid Ounce or Metric</b>	<b>Largest Quantity</b>	<b>Manufacturer :</b>	<b>Product:</b>	<b>Lot Code:</b>	<b>Plant Number:</b>						
1 cubic foot = 1728 cu in    *Total Volume (cu ft) (measure in in) = L × W × H ÷ 1728 or *Total Volume (L) (measure in mm) = L × W × H ÷ 1 000 000							<b>Dimensional Measurements</b>					
			Dimensions Measured in: <input type="checkbox"/> in <input type="checkbox"/> mm <input type="checkbox"/>			Package Error in:    mL    cu in						
	<b>Length</b>	<b>Avg</b>	<b>Width</b>			<b>Avg</b>	<b>Height</b>			<b>Avg</b>	<b>Total</b>	
<b>1.</b>												+
<b>2.</b>												-
<b>3.</b>												+
<b>4.</b>												-
<b>5.</b>												+
<b>6.</b>												-
<b>7.</b>												+
<b>8.</b>												-
<b>9.</b>												+
<b>10.</b>												-
<b>11.</b>												+
<b>12.</b>												-

**Appendix C: Inspection Worksheet for Dimensional Testing**

<p><b>Step 1.</b> What is the MAV for this labeled quantity in Table 2-6?</p> <p style="text-align: center;"> <input type="checkbox"/> _____ cu in  <input type="checkbox"/> _____ mL         </p>	<p style="text-align: center;"><b>Total Package Error</b></p>																				
<p><b>Step 2.</b> How many minus errors exceed the MAV _____? If the number of unreasonable errors exceeds the number permitted for the sample size in Table 2-1., the sample fails; go to Step 7. If there are no Unreasonable Errors, sum the package errors, and calculate the Average Error entering it in Step 3. Go to Step 4.</p>	<p style="text-align: center;"><b>Step 3: Average Package Error</b></p>																				
<p><b>Step 4.</b> If the Average Error is zero or a positive number, the sample passes; go to Step 7. If the Average Error is a negative number, go to Step 5.</p> <p><b>Step 5.</b> Calculate the Sample Standard Deviation (<i>s</i>) and multiply (<i>s</i>) by the Sample Correction Factor (<i>SCF</i>) for the sample size to obtain the Sample Error Limit (<i>SEL</i>); go to Step 6.</p> <p style="text-align: center;">(<i>s</i>) _____ × (<i>SCF</i>) _____ = <i>SEL</i> _____</p>	<p><b>Box 6.</b> Disregarding the signs, is the <i>SEL</i> in Step 5 larger than the Average Package Error in Step 3? If yes, the sample passes, go to Step 7 and approve the lot. If no, the sample fails, go to Step 7 and reject the lot.</p>																				
<p><b>Step 7. Action Taken:</b>   <input type="checkbox"/> Lot Rejected   <input type="checkbox"/> Lot Approved</p>																					
<p><b>Random Numbers:</b> Enter the numbers as you select them in the top row and reorder them in the bottom row.</p>																					
	<table border="1" style="width: 100%; border-collapse: collapse;"> <tr> <td style="width: 12.5%;"></td> <td style="width: 12.5%;"></td> <td style="width: 12.5%;"></td> <td style="width: 12.5%;"></td> <td style="width: 12.5%;"></td> <td style="width: 12.5%;"></td> <td style="width: 12.5%;"></td> <td style="width: 12.5%;"></td> <td style="width: 12.5%;"></td> <td style="width: 12.5%;"></td> </tr> <tr> <td></td> <td></td> <td></td> <td></td> <td></td> <td></td> <td></td> <td></td> <td></td> <td></td> </tr> </table>																				

THIS PAGE INTENTIONALLY LEFT BLANK

## Appendix D. Modified Standard Package Report for Animal Bedding

<b>Date:</b>	<b>Modified Standard Package Report for Animal Bedding</b>		<b>Sampling Plan A – Table 2-1., Appendix A in NIST Handbook 133</b>	<b>Report Number:</b>	
<b>This publication is available free of charge from: <a href="https://doi.org/10.6028/NIST.SP.1013">https://doi.org/10.6028/NIST.SP.1013</a></b>	<b>Location (name, address)</b>		<b>Product/Brand Identity</b>	<b>Manufacturer</b>	<b>Container Description:</b>
			<b>Lot Codes</b>		
<b>1. Labeled Quantity (Expanded Volume):</b>	<b>2. Unit of Measure: Liter</b>	<b>3. MAV:</b> - Single Volume Determination 5 % - Multiple Volume Determinations 10 %	<b>4. MAV (0.05 × Box 1. Expanded Volume) or (0.10 x Box 1. Expanded Volume)</b>	<b>5. Inspection Lot Size:</b>	<b>6. Sample Size (n):</b>
					<b>7. Number of Unreasonable Package Errors Allowed for Sample Size:</b>
<b>Gross Weight for Audit Testing</b>		<b>Package Error</b>		<b>Test Notes</b>	
		-	+		
		Total:	Total:		
<b>8. Total Error:</b>	<b>9. Number of unreasonable minus (-) errors (compare each package error with Box 4):</b>		<b>10. Is Box 9 greater than Box 7?</b> <input type="checkbox"/> Yes, lot <u>fails</u> go Box 17 <input type="checkbox"/> No, go to Box 11.	<b>11. Calculate Average Error: (Box 8 ÷ Box 6 =)</b>	
<b>12. Does Box 11 = Zero (0) or Plus</b> <input type="checkbox"/> Yes, lot <u>passes</u> , go to Box 17 <input type="checkbox"/> No, go to Box 13, 14, 15 & 16	<b>13. Compute Sample Standard Deviation:</b>		<b>14. Sample Correction Factor:</b>	<b>15. Compute Sample Error Limit (Box 13 × Box 14 =)</b>	
<b>16. Disregarding the signs, is Box 11 larger than Box 15?</b> <input type="checkbox"/> Yes, lot <u>fails</u> , go to Box 17 <input type="checkbox"/> No, lot <u>passes</u> , go to Box 17			<b>17. Disposition of Inspection Lot</b> <input type="checkbox"/> Approve <input type="checkbox"/> Reject		
<b>Comments:</b>			<b>Official's Signature</b>		
			<b>Acknowledgement of Report</b>		



THIS PAGE INTENTIONALLY LEFT BLANK

## **APPENDIX E. EXPERTS IN THE ANIMAL BEDDING INDUSTRY CONTACTED FOR TECHNICAL ASSISTANCE.**

**NIST EXTENDS ITS SINCERE APPRECIATION TO THESE EXPERTS FOR THEIR ADVICE AND ASSISTANCE.**

Richard Whiting, Vice President  
American Wood Fibers  
9841 Broken Land Parkway, #302  
Columbia, Maryland 21046  
E-mail: [rwhiting@awf.com](mailto:rwhiting@awf.com)  
Phone: 800-624-9663

Tony Parks, President  
Ozark Shavings  
200 Staples Lane  
Licking, Missouri 65542  
E-mail: [tony@ozarkshavings.com](mailto:tony@ozarkshavings.com)  
Phone: 573-674-9206

Keith Hellyer  
Sales and Distribution Manager  
Ozark Shavings  
200 Staples Lane  
Licking, Missouri 65542  
E-mail: [keith@ozarkshavings.com](mailto:keith@ozarkshavings.com)  
Phone: 573-674-9206

**For more information, please contact:**

Lisa Warfield, Technical Advisor  
NIST Office of Weights and Measures  
NCWM Laws and Regulations Committee  
E-mail: [lisa.warfield@nist.gov](mailto:lisa.warfield@nist.gov)  
Phone: 301-975-3308

David Sefcik, Technical Advisor  
NIST Office of Weights and Measures  
NCWM Laws and Regulations Committee  
E-mail: [david.sefcik@nist.gov](mailto:david.sefcik@nist.gov)  
Phone: 301-975-4868

THIS PAGE INTENTIONALLY LEFT BLANK

## Report of the Specifications and Tolerances (S&T) Committee

Mr. Mahesh Albuquerque, Committee Chair  
Colorado

### 300 INTRODUCTION

This is the final report of the Specifications and Tolerances (S&T) Committee (hereinafter referred to as the “Committee”) for the 100<sup>th</sup> Annual Meeting of the National Conference on Weights and Measures (NCWM). This report is based on the Interim Report offered in the NCWM Publication 16, “Committee Reports,” testimony at public hearings, comments received from the regional weights and measures associations and other parties, the addendum sheets issued at the Annual Meeting, and actions taken by the membership at the voting session of the Annual Meeting. The Informational items shown below were adopted as presented when this report was approved. This report contains those recommendations to amend National Institute of Standards and Technology (NIST) Handbook 44 (2015), “Specifications, Tolerances, and Other Technical Requirements for Weighing and Measuring Devices.”

Table A identifies the agenda and appendix items by reference key, title of item, page number, and the appendices by appendix designations. The acronyms for organizations and technical terms used throughout the agenda are identified in Table B. The first three digits of the Reference Key Numbers of the items are assigned from the Subject Series List. The status of each item contained in the report is designated as one of the following: **(D) Developing Item:** the Committee determined the item has merit; however, the item was returned to the submitter or other designated party for further development before any action can be taken at the national level; **(I) Informational Item:** the item is under consideration by the Committee but not proposed for Voting; **(V) Voting Item:** the Committee is making recommendations requiring a vote by the active members of NCWM; **(W) Withdrawn Item:** the item has been removed from consideration by the Committee.

Table C provides a summary of the results of the voting on the Committee’s items and the report in its entirety. Some Voting Items are considered individually; others may be grouped in a consent calendar. Consent calendar items are Voting Items that the Committee has assembled as a single Voting Item during their deliberation after the Open Hearings on the assumption that the items are without opposition and will not require discussion. The Voting Items that have been grouped into consent calendar items will be listed on the addendum sheets. Prior to adoption of the consent calendar, the Committee entertains any requests from the floor to remove specific items from the consent calendar to be discussed and voted upon individually.

Proposed revisions to the handbook(s) are shown as follows: 1) deleted language is indicated with a **bold face font using strikeouts** (e.g., ~~this report~~), 2) proposed new language is indicated with an **underscored bold faced font** (e.g., new items), and 3) nonretroactive items are identified in *italics*. When used in this report, the term “weight” means “mass.”

**Note:** The policy of NIST and NCWM is to use metric units of measurement in all of their publications; however, recommendations received by NCWM technical committees and regional weights and measures associations have been printed in this publication as submitted. Therefore, the report may contain references to U.S. customary units.

---

**Subject Series List**

---

Introduction .....	300 Series
NIST Handbook 44 – General Code.....	310 Series
Scales.....	320 Series
Belt-Conveyor Scale Systems .....	321 Series
Automatic Bulk Weighing Systems .....	322 Series
Weights.....	323 Series
Automatic Weighing Systems .....	324 Series
Liquid-Measuring Devices .....	330 Series
Vehicle-Tank Meters.....	331 Series
Liquefied Petroleum Gas and Anhydrous Ammonia Liquid-Measuring Devices .....	332 Series
Hydrocarbon Gas Vapor-Measuring Devices.....	333 Series
Cryogenic Liquid-Measuring Devices.....	334 Series
Milk Meters .....	335 Series
Water Meters .....	336 Series
Mass Flow Meters .....	337 Series
Carbon Dioxide Liquid-Measuring Devices.....	338 Series
Hydrogen Gas-Metering Devices – Tentative Code.....	339 Series
Vehicle Tanks Used as Measures .....	340 Series
Liquid Measures .....	341 Series
Farm Milk Tanks .....	342 Series
Measure-Containers.....	343 Series
Graduates.....	344 Series
Dry Measures .....	345 Series
Berry Baskets and Boxes.....	346 Series
Fabric-Measuring Devices.....	350 Series
Wire-and Cordage-Measuring Devices .....	351 Series
Linear Measures .....	352 Series
Odometers .....	353 Series
Taximeters.....	354 Series
Timing Devices .....	355 Series
Grain Moisture Meters .....	356 Series
Near-Infrared Grain Analyzers.....	357 Series
Multiple Dimension Measuring Devices .....	358 Series
Electronic Livestock, Meat, and Poultry Evaluation Systems and/or Devices – Tentative Code.....	359 Series
Other Items – Developing Items.....	360 Series

**Table A**  
**Table of Contents**

Reference Key	Title of Item	S&T Page
<b>300</b>	<b>INTRODUCTION .....</b>	<b>1</b>
<b>310</b>	<b>HANDBOOK 44 - GENERAL CODE .....</b>	<b>6</b>
310-1	D G-S.1. Identification. – (Software) .....	6
310-2	V G-UR.4.1. Maintenance of Equipment. ....	13
<b>320</b>	<b>SCALES.....</b>	<b>17</b>
320-1	W A.1. General.....	17
320-2	VC T.N.3.5. Separate Main Elements.....	22
320-3	W Table 7a. Typical Class or Type of Device for Weighing Applications.....	24
320-4	VC Part 2.20. Weigh-In-Motion Vehicle Scales for Law Enforcement – Work Group.....	25
<b>321</b>	<b>BELT-CONVEYOR SCALE SYSTEMS .....</b>	<b>28</b>
321-1	VC A.1. General.....	28
321-2	VC S.4. Marking Requirements. ....	30
321-3	VC N.2.1. Initial Verification.....	33
321-4	VC N.2.3. Minimum Test Load. ....	36
321-5	VC N.3.1.1. Determination of Zero.....	39
321-6	VC UR.1.2. Conveyor Installation.....	42
321-7	VC UR.3.1. Scale and Conveyor Maintenance. – <del>Belt conveyor scales</del> Weighing systems.....	44
321-8	VC Appendix D – Definitions. weigh-belt systems. ....	46
<b>322</b>	<b>AUTOMATIC BULK WEIGHING SYSTEMS .....</b>	<b>48</b>
322-1	D N.1. Testing Procedures.....	49
<b>324</b>	<b>AUTOMATIC WEIGHING SYSTEMS.....</b>	<b>57</b>
324-1	W A.1. General.....	57
<b>330</b>	<b>LIQUID MEASURING DEVICES .....</b>	<b>58</b>
330-1	W A.1. General.....	58
330-2	V Table S.2.2. Categories of Device and Methods of Sealing.....	59
330-3	W N.4.1.3. Normal Tests on Wholesale Multi-Point Calibration Devices.....	63
330-4	D N.4.5. Determination of Error on Wholesale Devices with Multiple Flow Rates and Calibration Factors .....	67
<b>331</b>	<b>VEHICLE-TANK METERS .....</b>	<b>73</b>
331-1	W N.4.1.4. Normal Tests on Wholesale Multi-Point Calibration Devices.....	73
331-2	D N.4.2.1. Determination of Error on Vehicle-Tank Meters with Multiple Flow Rates and Calibration Factors .....	75
<b>332</b>	<b>LPG AND ANHYDROUS AMMONIA LIQUID-MEASURING DEVICES.....</b>	<b>78</b>
332-1	I S.1.4.3. Provisions for Power Loss, S.1.5.1.1. Unit Price., S.1.5.1.2. Product Identity., S.1.6. For Retail Motor Vehicle Fuel Devices Only., S.1.7. For Wholesale Devices Only. , UR.2.7. Unit Price and Product Identity., and UR.2.8. Computing Device.....	79
332-2	D N.3. Test Drafts. ....	94
<b>337</b>	<b>MASS FLOW METERS .....</b>	<b>98</b>
337-1	V Appendix D – Definitions: Diesel Liter Equivalent (DLE) and Diesel Gallon Equivalents (DGE) for Compressed Natural Gas and Liquefied Natural Gas; Definition of Gasoline Gallon Equivalent and Gasoline Liter Equivalent for Compressed Natural Gas; S.1.2. Compressed Natural Gas and Liquefied Natural Gas Dispensers; S.1.3.1.1. Compressed Natural Gas Used as an Engine Fuel; S.1.3.1.2. Liquefied Natural Gas Used as an Engine Fuel; S.5.2. Marking of Diesel and Gasoline Volume Equivalent Conversion Factor; Compressed Natural Gas, S.5.3. Marking of Diesel Volume Equivalent Conversion Factor;	

		Liquefied Natural Gas, UR.3.1.1. Marking of Equivalent Conversion Factor for Compressed Natural Gas, UR.3.1.2. Marking of Equivalent Conversion Factor for Liquefied Natural Gas, and UR.3.8. Return of Product to Storage, Retail Compressed Natural Gas and Liquefied Natural Gas.....	98
337-2	W	S.3.6. Automatic Density Compensation.....	126
337-3	D	N.3. Test Drafts.....	130
<b>354</b>		<b>TAXIMETERS .....</b>	<b>132</b>
354-1	V	S.1.1.1. Recording Elements.....	132
354-2	I	S.1.2. Advancement of Indicating Elements.....	137
354-3	VC	S.1.3.3. Passenger Indications.....	140
354-4	VC	S.1.8. Protection of Indications.....	142
354-5	VC	S.1.9. Recorded Representation.....	143
354-6	D	USNWG on Taximeters – Taximeter Code Revisions and Global Positioning System-Based Systems for Time and Distance Measurement.....	146
<b>358</b>		<b>MULTIPLE DIMENSION MEASURING DEVICES .....</b>	<b>147</b>
358-1	W	Measurement of Bulk Material in Open-Top Truck and Trailer Units.....	148
<b>360</b>		<b>OTHER ITEMS.....</b>	<b>149</b>
360-1	W	Appendix D – Definitions: batching system.....	149
360-2	D	Appendix D – Definitions: calibration parameter and multi-point calibrated device.....	151
360-3	VC	Appendix D – Definitions. point-of-sale-system.....	153
360-4	D	Appendix D – Definitions: Remote Configuration Capability.....	155
360-5	VC	Electric Vehicle Fueling and Submetering.....	158

---

**Appendices**

---

A	Item 310-2: G-UR.4.1. Maintenance of Equipment – Background Information Provided by Mr. Henry Oppermann, Technical Director, Seraphin Test Measure Company, A Division of Pemberton Fabricators, Inc.....	A1
B	Items 320-1, 324-1, 330-1, and 360-1: Belt-Conveyor Scale Systems; Liquid Measuring Devices; and Definitions – Comments by Henry Oppermann, Weights and Measures Consulting.....	B1
C	Item 320-4: Draft Tentative Code Applicable to Weigh-In-Motion Systems Used for Vehicle Enforcement Screening.....	C1
D	Item 330-4: N.4.2.5. Determination of Error on Whole Sale Devices with Multiple Flow Rates and Calibration Factors.....	D1
E	Item 331-2: N.4.2.1. Determination of Error on Vehicle-Tank Meters with Multiple Flow Rates and Calibration Factors.....	E1
F	Item 337-1: Submitters Background and Justification for Handbook 44 Definition of “Diesel Gallon Equivalent (DGE)” of Compressed Natural Gas (CNG) and “Liquefied Natural Gas (LNG)” as a Vehicular Fuel.....	F1
G	Item 337-1: OWM’s Technical Analysis of Item 337-1.....	G1
H	Item 360-5: Electric Vehicle Fueling and Submetering Draft Code.....	H1
I	Item 360-5: Electric Vehicle Fueling and Submetering/Amendments to Timing Devices Code.....	I1

**Table B**  
**Glossary of Acronyms and Terms**

<b>Acronym</b>	<b>Term</b>	<b>Acronym</b>	<b>Term</b>
API	American Petroleum Institute	NCWM	National Conference on Weights and Measures
CC	Certificate of Conformance	NEWMA	Northeastern Weights and Measures Association
CNG	Compressed Natural Gas	NIST	National Institute of Standards and Technology
CWMA	Central Weights and Measures Association	NGSC	NCWM Natural Gas Steering Committee
DGE	Diesel Gallon Equivalent	NTEP	National Type Evaluation Program
DLE	Diesel Liter Equivalent	OIML	International Organization of Legal Metrology
DOT	Department of Transportation	OWM	Office of Weights and Measures
FALS	Fuels and Lubricants Subcommittee	RMFD	Retail Motor Fuel Dispenser
FHWA	Federal Highway Administration	S&T	Specifications and Tolerances
FMCSA	Federal Motor Carrier Safety Administration	SD	Secure Digital
GGE	Gasoline Gallon Equivalent	SI	International System of Units
GLE	Gasoline Liter Equivalent	SMA	Scale Manufacturers Association
GMM	Grain Moisture Meter	SWMA	Southern Weights and Measures Association
GPS	Global Positioning System	SS	Software Sector
IEC	International Electrotechnical Commission	TC	Technical Committee
LMD	Liquid Measuring Devices	USNWG	U.S. National Work Group
LNG	Liquefied Natural Gas	WG	Work Group
LMDP	Legal Metrology Devices Program	WIM	Weigh-in-Motion
MMA	Meter Manufacturers Association	WWMA	Western Weights and Measures Association
MPCG	NCWM Multi-Point Calibration Group	WS	Weighing Sector
MS	Measuring Sector		



**Table C**  
**Summary of Voting Results**

<i>Reference Key Number</i>	<i>House of Senate Representatives</i>		<i>House of Delegates</i>		<i>Results</i>
	<i>Yeas</i>	<i>Nays</i>	<i>Yeas</i>	<i>Nays</i>	
Consent Calendar 320-2, 320-4, 321-1, 321-2, 321-3, 321-4, 321-5, 321-6, 321-7, 321-8, 354-3, 354-4, 354-5, 360-3, 360-5	40	0	70	0	Adopted
310-2 To hear amendment	Majority to hear				Amendment was heard
310-2 To amend the proposal	38	3	65	1	Amendment Accepted
310-2 As Amended	38	3	65	1	Adopted
*337-1	32	8	26	31	Returned to Committee
354-1	27	9	57	8	Adopted
354-2	No Vote				Committee Moved to Informational Status

**Details of All Items**  
*(In order by Reference Key)*

### **310 HANDBOOK 44 - GENERAL CODE**

#### **310-1 D G-S.1. Identification. – (Software)**

**Source:**

This item originated from the NTEP Software Sector and first appeared on the Committee's 2007 Agenda as Developing Item Part 1, Item 1 and on its 2010 Agenda as Item 310-3.

**Purpose:**

Provide marking requirements that enable field verification of the appropriate version or revision for metrological software, including methods other than "permanently marked," for providing the required information.

**Item Under Consideration:**

Amend NIST Handbook 44 paragraph G-S.1. Identification as follows:

**G-S.1. Identification.** – All equipment, except weights and separate parts necessary to the measurement process but not having any metrological effect, shall be clearly and permanently marked for the purposes of identification with the following information:

- (a) the name, initials, or trademark of the manufacturer or distributor;
- (b) a model identifier that positively identifies the pattern or design of the device;
  - (1) *The model identifier shall be prefaced by the word “Model,” “Type,” or “Pattern.” These terms may be followed by the word “Number” or an abbreviation of that word. The abbreviation for the word “Number” shall, as a minimum, begin with the letter “N” (e.g., No or No.). The abbreviation for the word “Model” shall be “Mod” or “Mod.” Prefix lettering may be initial capitals, all capitals, or all lowercase.*  
*[Nonretroactive as of January 1, 2003]*  
 (Added 2000) (Amended 2001)
- (c) *a nonrepetitive serial number, except for equipment with no moving or electronic component parts and ~~not built for purpose software-based software devices~~ software;*  
*[Nonretroactive as of January 1, 1968]*  
 (Amended 2003)
  - (1) *The serial number shall be prefaced by words, an abbreviation, or a symbol, that clearly identifies the number as the required serial number.*  
*[Nonretroactive as of January 1, 1986]*
  - (2) *Abbreviations for the word “Serial” shall, as a minimum, begin with the letter “S,” and abbreviations for the word “Number” shall, as a minimum, begin with the letter “N” (e.g., S/N, SN, Ser. No., and S. No.).*  
*[Nonretroactive as of January 1, 2001]*
- (d) the current software version or revision identifier for not-built-for-purpose software-based devices; **manufactured as of January 1, 2004 and all software-based devices or equipment manufactured as of January 1, 2020;**  
~~*[Nonretroactive as of January 1, 2004]*~~  
 (Added 2003) **(Amended 20XX)**
  - (1) *The version or revision identifier shall be:*
    - i. *prefaced by words, an abbreviation, or a symbol, that clearly identifies the number as the required version or revision;*  
*[Nonretroactive as of January 1, 2007]*  
 (Added 2006)

**Note: If the equipment is capable of displaying the version or revision identifier but is unable to meet the formatting requirement, through the NTEP type evaluation process, other options may be deemed acceptable and described in the CC.**

**(Added 20XX)**

- ii. directly linked to the software itself; and  
[Nonretroactive as of January 1, 2020]  
(Added 20XX)
- iii. continuously displayed or be accessible via the display. Instructions for displaying the version or revision identifier shall be described in the CC. As an exception, permanently marking the version or revision identifier shall be acceptable providing the device does not have an integral interface to communicate the version or revision identifier.  
[Nonretroactive as of January 1, 2020]  
(Added 20XX)

(2) Abbreviations for the word “Version” shall, as a minimum, begin with the letter “V” and may be followed by the word “Number.” Abbreviations for the word “Revision” shall, as a minimum, begin with the letter “R” and may be followed by the word “Number.” The abbreviation for the word “Number” shall, as a minimum, begin with the letter “N” (e.g., No or No.). Prefix lettering may be initial capitals, all capitals, or all lowercase.  
[Nonretroactive as of January 1, 2007]  
(Added 2006)

(e) a National Type Evaluation Program (NTEP) Certificate of Conformance (CC) number or a corresponding CC Addendum Number for devices that have a CC.

(1) The CC Number or a corresponding CC Addendum Number shall be prefaced by the terms “NTEP CC,” “CC,” or “Approval.” These terms may be followed by the word “Number” or an abbreviation of that word. The abbreviation for the word “Number” shall, as a minimum, begin with the letter “N” (e.g., No or No.)  
[Nonretroactive as of January 1, 2003]

The required information shall be so located that it is readily observable without the necessity of the disassembly of a part requiring the use of any means separate from the device.

(Amended 1985, 1991, 1999, 2000, 2001, 2003, ~~and~~, 2006 ~~and~~ **20XX**)

#### **Background/Discussion:**

Among other tasks, the NTEP Software Sector (SS) was charged by the NCWM Board of Directors to recommend NIST Handbook 44 specifications and requirements for software incorporated into weighing and measuring devices and systems, which may include tools used for software identification. During its October 2007 meeting, the SS discussed the value and merits of required markings for software, including possible differences in some types of software-based devices and methods of marking requirements. After hearing several proposals, the Sector agreed to the following technical requirements applicable to the marking of software:

1. The NTEP CC Number must be continuously displayed or hard-marked;
2. The version must be software-generated and shall not be hard-marked;
3. The version is required for embedded (Type P) software;
4. Printing the required identification information can be an option;
5. Command or operator action can be considered as an option in lieu of a continuous display of the required information; and
6. Devices with Type P (embedded) software must display or hard-mark the device make, model, and serial number to comply with G S.I. Identification.

In 2008, the Software Sector developed and submitted a proposal to the NCWM S&T Committee to modify G-S.1. and associated paragraphs to reflect these technical requirements. Between 2008 and 2011, this item appeared on the S&T Committee's main agenda, and the Committee and the Sector received numerous comments and suggestions relative to the proposal. The Sector developed and presented several alternatives based on feedback from weights and measures officials and manufacturers. Among the key points and concerns raised during discussions over this period were how to address the following:

- (a) **Limited Character Sets and Space.** – How to address devices that have limited character sets or restricted space for marking.
- (b) **Built-for-Purpose vs. Not-Built-for-Purpose.** – Whether or not these should be treated differently.
- (c) **Ease of Access.** – Ease of accessing marking information in the field.
  - Complexity of locating the marking information
  - Use of menus for accessing the marking information electronically
  - Limits on the number of levels required to access information electronically
  - Possibility of single, uniform method of access
- (d) **Hard Marking vs. Electronic.** – Whether or not some information should be required to be hard marked on the device.
- (e) **Continuous Display.** – Whether or not required markings must be continuously displayed.
- (f) **Abbreviations and Icons.** – Establishment of unique abbreviations, identifiers, and icons and how to codify those.
- (g) **Certificate of Conformance Information.** – How to facilitate correlation of software version information to a CC, including the use of possible icons.

Further details on the alternatives considered can be found in the Committee's Final Reports from 2008 to 2014.

Prior to the 2014 NTEP Weighing Sector (WS) meeting, members of OWM's Legal Metrology Devices Program (LMDP) amended the proposal appearing on the Committee's Agenda in 2014; this after being asked by the NTEP SS to provide additional input and draft modifications to Paragraphs G-S.1. and G.S.1.1. in consideration of the goals of the SS and the comments provided during the 2014 Open Hearings of the S&T Committee relating to this item.

The following is a list of the goals provided by the SS in modifying G-S.1. and G.S.1.1. as communicated to the members of OWM's LMDP:

1. Remove the existing distinction between software identification requirements for built-for-purpose and not-built-for-purpose devices.
2. Require that all software-based devices have a software version or revision identifier for metrologically significant software.
3. Require that certified software versions or revision identifiers for metrologically significant software is recorded on the CC for access by inspectors.
4. Software itself does not require serial numbers.

5. Require that a software-based device's version or revision identifier shall be accessible via the display and user interface. Only if device's display is incapable of displaying the identifier or has no display and/or interface shall permanently mark the version or revision identifier be acceptable (e.g., digital load cell).
6. Nonretroactive as of January 1, 2016, if adopted by the NCWM in July 2015.

OWM's LMDP developed the following proposed draft alternative changes to G-S.1. based on the SS's request for additional input on how best to meet its goals and forwarded these changes to the Chairman of the SS for consideration at the 2014 WS/SS joint meeting:

Amend NIST Handbook 44: G-S.1. as follows:

**G-S.1. Identification.** – All equipment, except weights and separate parts necessary to the measurement process but not having any metrological effect, shall be clearly and permanently marked for the purposes of identification with the following information:

- (a) the name, initials, or trademark of the manufacturer or distributor;
- (b) a model identifier that positively identifies the pattern or design of the device;
  - (1) *The model identifier shall be prefaced by the word "Model," "Type," or "Pattern." These terms may be followed by the word "Number" or an abbreviation of that word. The abbreviation for the word "Number" shall, as a minimum, begin with the letter "N" (e.g., No or No.). The abbreviation for the word "Model" shall be "Mod" or "Mod." Prefix lettering may be initial capitals, all capitals, or all lowercase.*  
*[Nonretroactive as of January 1, 2003]*  
(Added 2000) (Amended 2001)
- (c) *a nonrepetitive serial number, except for equipment with no moving or electronic component parts and ~~not built for purpose software-based devices~~ software;*  
*[Nonretroactive as of January 1, 1968]*  
(Amended 2003)
  - (1) *The serial number shall be prefaced by words, an abbreviation, or a symbol, that clearly identifies the number as the required serial number.*  
*[Nonretroactive as of January 1, 1986]*
  - (2) *Abbreviations for the word "Serial" shall, as a minimum, begin with the letter "S," and abbreviations for the word "Number" shall, as a minimum, begin with the letter "N" (e.g., S/N, SN, Ser. No., and S. No.).*  
*[Nonretroactive as of January 1, 2001]*
- (d) the current software version or revision identifier for not-built-for-purpose software-based devices; manufactured as of January 1, 2004 through December 31, 2015, and all software based devices or equipment manufactured as of January 1, 2016;  
*[Nonretroactive as of January 1, 2004]*  
(Added 2003) (**Amended 20XX**)
  - (1) *The version or revision identifier shall be:*

- i. *prefaced by words, an abbreviation, or a symbol, that clearly identifies the number as the required version or revision;*  
[Nonretroactive as of January 1, 2007]  
(Added 2006)
- ii. ***directly linked to the software itself; and***  
***[Nonretroactive as of January 1, 2016]***  
**(Added 20XX)**
- iii. ***continuously displayed\* or be accessible via the display menus. Instructions for displaying the version or revision identifier shall be described in the CC. As an exception, permanently marking the version or revision identifier shall be acceptable providing the device does not have an integral interface to communicate the version or revision identifier.***  
***[Nonretroactive as of January 1, 2016]***  
**(Added 20XX)**

***\*The version or revision identifier shall be displayed continuously on software-based equipment with a digital display manufactured as of January 1, 20XX, and all software-based equipment with a digital display as of January 1, 20YY.***

- (2) *Abbreviations for the word “Version” shall, as a minimum, begin with the letter “V” and may be followed by the word “Number.” Abbreviations for the word “Revision” shall, as a minimum, begin with the letter “R” and may be followed by the word “Number.” The abbreviation for the word “Number” shall, as a minimum, begin with the letter “N” (e.g., No or No.).*  
[Nonretroactive as of January 1, 2007]  
(Added 2006)
- (e) *a National Type Evaluation Program (NTEP) Certificate of Conformance (CC) number or a corresponding CC Addendum Number for devices that have a CC.*
  - (1) *The CC Number or a corresponding CC Addendum Number shall be prefaced by the terms “NTEP CC,” “CC,” or “Approval.” These terms may be followed by the word “Number” or an abbreviation of that word. The abbreviation for the word “Number” shall, as a minimum, begin with the letter “N” (e.g., No or No.)*  
[Nonretroactive as of January 1, 2003]

The required information shall be so located that it is readily observable without the necessity of the disassembly of a part requiring the use of any means separate from the device.

(Amended 1985, 1991, 1999, 2000, 2001, 2003, **and**, 2006 **and 20XX**)

OWM’s LMDP did not propose any changes to subparagraph G-S.1.1. since the SS had indicated earlier that it may be possible to eventually eliminate G-S.1.1. Additionally, the LMDP explained to the SS that the shaded portion of G-S.1.(d)(1)iii. of their draft alternative changes did not reflect any of the goals communicated by the SS and was being offered for consideration with the understanding that:

1. this change will make it easier in the future for inspectors to be able to identify software installed in equipment;
2. a reasonable amount of time for the changes to take effect can be specified; and

3. it is probable that improvements in technology over time will make it easier for equipment manufacturers to comply.

**NTEP Weighing and Software Sectors – Joint Meeting (August 2014):**

At its 2014 meeting, the Weighing Sector (WS) met jointly with the Software Sector (SS) to consider the proposal as amended by OWM’s LMDP. After further amending it, the two Sectors agreed to submit the proposal as shown in the Item Under Consideration to the weights and measures regional associations for consideration, and requested its status be change from Developing to Informational. The Sectors also decided that no changes to G-S.1.1. were necessary since the two Sectors had agreed that the term “not-built-for-purpose software-based devices” in G-S.1.(d) would be retained in the proposal.

**2015 NCWM Interim Meeting:**

During the 2015 NCWM Interim Meeting, representatives speaking on behalf of the SMA, MMA, and OWM commented that they believed progress had been made on this item at the joint meeting of the SS and WS in August 2014. The SMA reported it continues to support the work of the SS and would like to see this item remain on the S&T Committee’s Agenda. OWM noted that during the joint meeting members of both Sectors had agreed to a number of proposed amendments to G-S.1., which had been developed by OWM’s LMDP. OWM encouraged the SS to continue working with the remaining NTEP Sectors to try and reach consensus on a proposal that provides the means for officials to easily determine whether or not software installed in a device is the same as that evaluated by NTEP. Mr. Michael Keilty (Endress Hauser Flowtec AG), Chairman of the Measuring Sector (MS), reported the Measuring Sector (MS) would be meeting with the SS next October (2015) to consider the proposal.

In recognition of the progress that was reported and the planned future joint meeting of the Measuring and Software Sectors, the Committee agreed to keep the item on its agenda as a Developing item. However, because this item has remained on S&T’s Agenda for several years, the Committee also agreed it would withdraw the item if a proposal that can be presented for vote is not received before the next NCWM Interim Meeting.

**2015 NCWM Annual Meeting:**

At the 2015 NCWM Annual Meeting, Mr. Russ Vires (Mettler-Toledo, LLC), speaking on behalf of the SMA, commented that the SMA continues to support the work of the SS and looks forward to the outcome of their joint meeting with the MS.

Ms. Tina Butcher (OWM) reported that significant progress was made at last year’s joint meeting of the SS and WS. OWM continues to support the efforts of the SS and looks forward to the outcome of their joint meeting with the MS in September 2015. She encouraged the SS to continue working with the remaining NTEP Sectors to try and reach consensus on a proposal, which provides the means for officials to be able to easily determine whether or not software installed in a device is the same as that evaluated by NTEP.

Committee member, Dr. Matthew Curran (Florida) asked if it was still the plan of the SS to have the proposal developed to the extent that it could be a Voting item during the 2016 NCWM cycle. Mr. Richard Harshman (OWM), Co-Technical Advisor to the Committee, responded that was still his understanding.

The Committee also noted again, due to the length of time the item has remained on the Committee’s Agenda with no resolution (8 years), that if proposed language for voting status consideration could not be presented to the Committee by the 2016 Interim Meeting it would likely be withdrawn, but could be reintroduced when the Sectors were able to provide such language.

In consideration of the comments received in support of the item, which also acknowledged the recent significant progress to further develop it, the Committee agreed to maintain the item on its agenda in a Developing status. The Committee also agreed to replace the Item Under Consideration with the most recent proposal; which was agreed to by the SS and WS during their joint 2014 meeting and as now shown in Item Under Consideration.

**Regional Association Meetings:**

The CWMA recommended leaving this as a Developing item at its 2014 Interim Meeting due to the lack of new information from the SS. At its 2015 Annual Meeting, the CWMA again recommended the item move forward as Developing due to comments heard during the Open Hearing and the upcoming meeting between the SS and MS.

WWMA heard testimony in Open Hearings of the 2014 WWMA Annual Meeting in support of the work being done and the interested Sectors are meeting to continue the effort. WWMA agreed further work needs to be done with this item. WWMA recommended this item remain a Developing item.

At its 2014 Annual Meeting, the SWMA recommended this item remain Developing despite having indicated last year that if no progress had been made by the next NCWM cycle the item would be Withdrawn. While there were no specific updates provided, there were comments indicating progress has been made by the SS and WS. The Committee did not hear any comments in opposition to this item.

At its 2014 Interim Meeting, NEWMA recommended that the item be Withdrawn because no new information had been provided by the SS. It was noted that if the SS continues their work on this item and wants to bring this forward again with new information; the Committee could reconsider the item. At its 2015 Annual Meeting, NEWMA heard testimony indicating significant progress had been made on the item by the SS. A question was raised concerning whether or not the current proposal would exempt software from being required to have a serial number. The Committee reported it believes the current proposal would exempt software. NEWMA agreed to recommend the item move forward as Developing because of the ongoing work being done to further develop this item.

Additional letters, presentations, and data may have been part of the Committee's consideration. To review the supporting documentation, please refer to the *Report of the 99<sup>th</sup> National Conference on Weights and Measures* (SP1193, 2014).

**310-2 V G-UR.4.1. Maintenance of Equipment.**

(This item was adopted.)

**Source:**

Florida Department of Agriculture and Consumer Services (2015)

**Purpose:**

To further clarify the applicability of the General Code to device types or flow rates at a single facility.

**Item Under Consideration:**

Amend NIST Handbook 44 General Code as follows:

**G-UR.4.1. Maintenance of Equipment.** – All equipment in service and all mechanisms and devices attached thereto or used in connection therewith shall be continuously maintained in proper operating condition throughout the period of such service. Equipment in service at a single place of business ~~found to be in error predominantly in a direction favorable to the device user (Also see the Introduction, Section Q)~~ shall not be considered “maintained in a proper operating condition.” **if:**

**(a) Predominantly, equipment of all types or applications are found to be in error in a direction favorable to the device user, or**

**(b) Predominantly, equipment of the same type or application is found to be in error in a direction favorable to the device user.**

(Amended 1973, ~~and~~ 1991, and 2015)



**Background/Discussion:**

It is not uncommon for a single place of business to have in use different types of devices (or meters with different flow rates) at the same time. A truck stop may have retail meters for passenger vehicles and high-volume meters for commercial vehicles, both having different tolerances and essentially operating as separate sections at a single place of business. As this section is currently written, it would include both of these meter types under “equipment” and thus apply “predominantly in favor” across all meters, despite the fact that one group of these meters could be predominantly in favor of the vendor while the other is not, thus, leaving the weights and measures official without the ability to correct such a situation under the general code. Similar situations may exist with scales and other measuring devices. Further clarifying ‘equipment’ to apply to the same type or application use in this section would alleviate that potential. Consequently, the submitter of the item proposed the following amendments to paragraph G-UR.4.1.

**G-UR.4.1. Maintenance of Equipment** – All equipment in service and all mechanisms and devices attached thereto or used in connection therewith shall be continuously maintained in proper operating condition throughout the period of such service. Equipment **of the same type or application** in service at a single place of business found to be in error predominantly in a direction favorable to the device user (See also Introduction, Section Q.) shall not be considered “maintained in a proper operating condition.”

**2015 NCWM Interim Meeting:**

At the 2015 NCWM Interim Meeting, there were a number of concerns raised during the S&T Committee Open Hearings regarding the impact this proposal might have on the application of the paragraph as it relates to predominance. There were also a number of state weights and measures officials who spoke in support of the proposed change. Ms. Tina Butcher (OWM) commented that OWM believes the current language in G-UR.4.1. is adequately broad to provide jurisdictions the flexibility of being able to establish policies and guidelines for assessing “predominance.” However, if the Committee believes that a change is needed to this paragraph to assist jurisdictions who are having difficulty enforcing the requirements; the current proposal might be too restrictive. The current language would limit how a jurisdiction can apply the requirement and would not enable other groupings or attributes to be considered. For example, if a gasoline station sets its most frequently used dispensers to operate in the station’s favor, the proposed language would not allow the jurisdiction to apply the requirement and consider this to be a scenario of “predominance.” OWM offered the following alternative language for consideration should the Committee decide changes were needed:

**G-UR.4.1. Maintenance of Equipment** – All equipment in service and all mechanisms and devices attached thereto or used in connection therewith shall be continuously maintained in proper operating condition throughout the period of such service. Equipment in service at a single place of business found to be in error predominantly in a direction favorable to the device user **(including, but not limited to, equipment of the same type or application)** shall not be considered “maintained in a proper operating condition.” ~~(see also Introduction, Section Q)~~

Ms. Butcher also noted that the reference to “Introduction, Section Q” should be deleted from the paragraph because the Introduction Section of NIST Handbook 44 was amended in 2013, resulting in Section M. being deleted and subsequent sections renumbered. Consequently, Section P. is now the correct reference, but referencing it in G-UR.4.1. is of no benefit in OWM’s view.

Dr. Matthew Curran (Florida), submitter of the item, reported that the marketplace has changed over the years, and today, many facilities are multi-dimensional with respect to commodities they sell (e.g., a business might sell gasoline out front along with diesel through high-flow meters in the back, while selling frozen yogurt, meats, etc., by weight inside) as opposed to offering just one particular product or commodity as in the past. Thus, many facilities now have multiple different types of weighing and measuring devices in use at the same place of business. He went on to state that if a business of this nature had all devices of one particular device type set on the negative or short side (for whatever reason), but each device was within tolerance and the other devices of other types were random, the number of those affected devices of that particular type wouldn’t constitute “predominance.” For example, if six diesel meters in the truck lanes out back were all on the short side (set that way because they made the most money from them or for whatever reason), but were within tolerance and the 12 retail meters out front and the five scales inside were random, the six diesel meters all on the short side would not constitute “predominance” at that location and the jurisdiction could not address the issue. In such instances, the jurisdiction would have no mechanism to remove those

devices from service, but if the code was changed to address today's marketplace, jurisdictions would have a mechanism to address this problem. Further, jurisdictions could still look at the total number of devices regardless of type, thus, making this language more flexible overall and not more restrictive. Dr. Curran specifically added that although NIST stated this language was more restrictive, it was actually less restrictive and gave the jurisdiction definitive authority to do what many were already doing in this regard. Dr. Curran went on to state that this issue was also introduced by Ms. Julie Quinn (Minnesota) last year in a proposal for the Liquid Measuring Devices (LMD) Code, but the S&T Committee stated it felt it would be more appropriate to address this in the General Code.

Mr. Henry Oppermann (Weights and Measures Consulting, LLC) speaking on behalf of Seraphin Test Measure Company, noted that predominance is typically applied to the errors resulting from the testing of retail motor fuel dispensers at a gas station. Proposals to provide guidance and promote uniformity in the assessment of the predominance of error, particularly regarding retail motor fuel devices, have been addressed several times over the years by the S&T Committee. He reported that Seraphin (Test Measure Company) supports the efforts to achieve greater uniformity in the interpretation and assessment of the predominance in errors. Mr. Oppermann provided background information containing excerpts from a draft training manual, "Introduction to Liquid Measuring Devices," that had been prepared for the NIST Office of Weights and Measures that provide an indication of the effects of temperature on test results for liquid measuring systems. This information has been inserted in Appendix A of this report. Mr. Oppermann also provided a copy of one state's policy in applying existing NIST Handbook 44 requirements associated with predominance to commercial retail dispensers.

Mr. Kurt Floren (Los Angeles County, California) voiced opposition to the proposed changes noting that predominance applies not only to retail motor fuel dispensers, but also to other weights and measures equipment, such as scales and other devices. He suggested possibly focusing in on the different applications and inserting requirements into the different codes of NIST Handbook 44 to address this concern. After Dr. Curran provided a more detailed explanation of the intent of the proposed change, Mr. Floren added he appreciated the clarification and did not have that understanding when he voiced his opposition but now understands the concerns this issue addresses.

The SMA provided comment in opposition to the item noting while it understands the intent of the item, it feels the existing language is sufficient to address the concern.

Ms. Quinn spoke in support of this item and provided related examples from grocery stores in her state. Ms. Quinn mentioned her similar proposal item last year for the LMD Code that the Committee opted to withdraw as it felt would be more appropriately addressed in the General Code.

Mr. Doug Deiman (Alaska) also spoke in support of this item and provided examples relating to hanging scales in his state.

In consideration of the comments received, the Committee agreed to amend the second sentence of paragraph G-UR.4.1.; delete the reference to "Introduction, Section Q" as shown below; and recommend the item for Vote.

**G-UR.4.1. Maintenance of Equipment** – All equipment in service and all mechanisms and devices attached thereto or used in connection therewith shall be continuously maintained in proper operating condition throughout the period of such service. Equipment in service at a single place of business **(including, but not limited to, equipment of the same type or application)** found to be in error predominantly in a direction favorable to the device user shall not be considered "maintained in a proper operating condition." ~~(see also Introduction, Section Q)~~

#### 2015 NCWM Annual Meeting:

At the 2015 NCWM Annual Meeting, the Committee heard a number of comments in both support and opposition to the proposal shown above. An industry representative voiced support for the intent of the changes, but encouraged additional review, questioning whether or not the language being proposed provided sufficient clarity. Several officials agreed with the comment.

Ms. Kristin Macey (California) commented that the additional language is not needed and questioned whether or not the LMD Code might be a more appropriate place to address "predominance." Mr. Steve Giguere (Maine) stated that he agreed with Ms. Macey's comments. Mr. Randy Jennings (Tennessee), Ms. Julie Quinn (Minnesota), and Mr. Mike

Sikula (New York) all supported the item. Mr. Constantine Cotsoradis (Flint Hills Resources) stated he supported the intent, but was concerned the language didn't accomplish the intent, to which Ms. Macey now agreed and proposed reverting to the original language, which was presented at the Interim. Mr. Tim Chesser (Arkansas) agreed it needed to be in the General Code as well and echoed Ms. Macey's suggestion to revert to the original language.

Dr. Curran, submitter of the item stated, in response to Ms. Macey's and Mr. Giguere's initial comments, he believed the General Code was the appropriate place to address this issue, and he noted that the S&T Committee withdrew a similar item last year that had been proposed specifically for the LMD Code as the Committee felt it was more appropriate in the General Code. Dr. Curran provided a hypothetical, but possible example of a business with 5 heavily used scales (and a significant portion of the businesses overall sales) inside and 15 fueling pumps outside where the 5 scales were within tolerance, but all set on the negative side and the 15 fueling pumps outside were all within tolerance, but not necessarily on the negative side, the weights and measures official would not be able to take the five scales out of service under this section of the General Code if a predominant number of the devices were not on the negative side, thus allowing the business to 'skim' from its customers. He further reiterated that several jurisdictions indicated they were already interpreting the General Code this way, which, he added, was further support for codifying what was already being interpreted by many weights and measures officials.

A representative from Connecticut stated the proposed change was not necessary. Mr. Richard Tucker (RL Tucker Consulting) expressed concern for placing examples in the General Code and provided a history of its inception in 1973. Mr. Richard Shapiro (Rice Lake) expressed concern that this change, if adopted, would put them in a "sticky" situation.

Mr. Russ Vires (Mettler-Toledo, LLC), speaking on behalf of the SMA, noted that the SMA took no position on this item.

Ms. Butcher reiterated comments NIST, OWM made during the 2015 Interim Meeting that the current language in paragraph G-UR.4.1. is adequately broad to provide jurisdictions the flexibility of being able to establish policies and guidelines for assessing "predominance" of equipment. OWM noted that the original proposal had been amended using alternative language provided by OWM. OWM commented that it believes the proposal is appropriate if others believe, as the submitter does, the change will strengthen a jurisdiction's ability to enforce this paragraph as it relates to "predominance."

OWM also noted if the Committee decided not to advance this proposal, the reference to Introduction, Section Q should still be deleted editorially; not only is the reference incorrect, it is of little benefit in interpreting and understanding the paragraph.

In considering the comments, the proposal received during the Open Hearings, the Committee agreed during its work session to amend the Item Under Consideration by reverting back to the language originally proposed by the submitter of the item and recommend the item be presented for Vote. Thus, the Committee agreed to replace the Item Under Consideration with the following:

**G-UR.4.1. Maintenance of Equipment** – All equipment in service and all mechanisms and devices attached thereto or used in connection therewith shall be continuously maintained in proper operating condition throughout the period of such service. Equipment **of the same type or application** in service at a single place of business ~~(including, but not limited to, equipment of the same type or application)~~ found to be in error predominantly in a direction favorable to the device user shall not be considered "maintained in a proper operating condition." ~~(see also Introduction, Section Q)~~

During the voting session, Mr. Floren commented that he agreed with the intent of the proposal, yet was still having difficulty with the language proposed. He suggested amending the Item Under Consideration by creating two bulleted sentences within the paragraph to address the two different applications for which the paragraph is intended to apply. He offered some suggested changes, to which others, including the submitter agreed. Ms. Macey also stood in support of the proposed changes. The language was amended on the floor by the Committee as shown in the Item Under Consideration; voted on; and adopted.

**Regional Association Meetings:**

At its 2014 Interim Meeting, the CWMA S&T Committee received comments in support of this item. Multiple jurisdictions indicated that they believe the proposed changes will give them a stronger legal position. The CWMA agreed the proposed changes would strengthen the application of this code and forwarded the item to NCWM, recommending it as a Voting item. During the 2015 CWMA Annual Meeting, the CWMA reversed its earlier position and agreed to recommend the item be Withdrawn after indicating it believed the current language used in NIST Handbook 44 is sufficient. The CWMA also indicated it was in favor of striking the reference “(see also Introduction, Section Q)” from G-UR.4.1.

At the 2014 WWMA Annual Meeting, opposition to this item was expressed during Open Hearings. Several regulators spoke to the potential for multiple interpretations/confusion and the belief that the intent of the proposal was geared toward LMD in spite of it being located in the General Code. Based on testimony given, WWMA did not forward this item to the NCWM.

At its 2014 Annual Meeting, the SWMA did not hear any comments in opposition to this item and supported the intent to clarify this section and make it more defensible. The SWMA reported that it also believes the recommended language strengthens the existing paragraph. The SWMA forwarded the item to the NCWM and recommended that it be a Voting item.

NEWMA reported at its 2014 Interim Meeting that it believes the proposal provides beneficial clarification to the General Code. NEWMA forwarded the item to the NCWM and recommended that it be a Voting item. At its 2015 Annual Meeting, NEWMA agreed to recommend the item for Vote based on the belief the item has merit.

Additional letters, presentations, and data may have been part of the Committee’s consideration. To review the supporting documentation, please refer to the *Report of the 99<sup>th</sup> National Conference on Weights and Measures* (SP1193, 2014).

**320 SCALES****320-1 W A.1. General.**

(This item was Withdrawn.)

**Source:**

KSi Conveyors, Inc. (2015)

**Purpose:**

Provide clarity in NIST Handbook 44 as to what standards apply to weighing and measuring systems that provide a finished product based on the measurement of raw materials.

**Item Under Consideration:**

Amend NIST Handbook 44 Scales Code as follows:

**A.1. General.** – This code applies to all types of weighing devices other than automatic bulk-weighing systems, belt-conveyor scales, and automatic weighing systems, **including non-automatic batching systems**. The code comprises requirements that generally apply to all weighing devices, and specific requirements that are applicable only to certain types of weighing devices.

(Amended 1972 and 1983)

**Background/Discussion:**

The reference to batching systems will accompany the proposal to add a definition for “batching systems” to NIST Handbook 44, Appendix D – Definitions. The CWMA agreed to forward the definition to the NCWM S&T Committee with the recommendation that it be a Voting item. The CWMA noted that the definition needs to reference the specific codes where the definition is applicable.

There are both automatic and non-automatic batching systems that utilize scales and/or meters already in the market place and have been for many years. The lack of a definition and the accompanying references may have just been an oversight on the part of the NCWM S&T Committee. For further clarification and justification please refer to the proposal to add a definition for “batching systems,” which was also submitted to the SWMA for consideration.

At the 2015 NCWM Interim Meeting, the Committee agreed to group together Agenda Items 320-1, 324-1, 330-1, and 360-1 since these items are related and announced comments on all four items would be taken together during the Committee’s Open Hearings.

Short presentations concerning these items were provided by Mr. Henry Oppermann (Weights and Measures Consulting, LLC) and Mr. Dominic Meyer (KSi Conveyors, Inc.), both of whom described the automatic operation of a seed treatment process involving a hopper scale used to weigh the seed. In describing the scale’s operation, Mr. Oppermann classified the scale as an automatic bulk weighing system (ABWS). He stated, it is the application of a scale that defines its classification. In a typical seed weighing operation, seed is loaded, weighed, and discharged from the hopper automatically and in repeated drafts until the weight of an order, which is pre-programmed into the system by an operator, is filled. Since only a single commodity is weighed, the scale cannot be classified as a batching scale, which would require two or more commodities to be weighed. The application of the scale makes it an ABWS. He stated that the scale does not comply with the ABWS Code because it does not record the no-load and loaded weight values accumulating the net weight of each draft, and there may be other compliance issues. He indicated it doesn’t make sense to include the term “batching system” in the Application Section of several NIST Handbook 44 device codes when nowhere within those codes are there specific requirements that apply to them. Mr. Oppermann also provided written comments to the Committee summarizing his opposition to the four proposals; these have been inserted into Appendix B of this report.

Mr. Richard Suiter (Richard Suiter Consulting) provided testimony on behalf of KSi Conveyors, Inc. He reported that he had contacted a number of different states about the KSi system. Some states questioned whether scales used to weigh seed should be considered grain-hopper scales. The Federal Grain Inspection Service (FGIS) does not consider seed a grain. Mr. Suiter provided a short history of the ABWS Code dating back to the late 1970s when a manufacturer produced an electronic weighing system designed to replace old mechanical “trip weighers,” which consisted of a mechanical hopper scale that would fill with grain to a preset weight then trip and dump. A problem encountered with these electronic automatic weighing systems was that the weigh hopper would sometimes fail to completely empty when grain was discharged from the weigh hopper. As a result, the scale did not return to zero after each load had been discharged because of product left remaining (often referred to as a “heel”) in the weigh hopper. At some point during a subsequent draft, the “heel” would discharge out of the weigh hopper along with the rest of the load; this caused a zero load balance change on the negative side of zero, which did not comply with NIST Handbook 44 and would cause the system to “lock up.” The manufacturer of the system worked closely with the State of Nebraska and FGIS to recognize a system that would utilize “no-load reference values” that could be on either the negative or positive sides of zero. This effort resulted in the initial version of the ABWS for Grain Code being adopted by the NCWM in 1983.

Mr. Suiter reported that KSi Conveyors had submitted and received an NTEP CC for a bulk weighing system controller used in an ABWS application after one state had classified the system as an ABWS. He also stated that NTEP had already determined that the earlier system in question was not an ABWS and so stated on the Certificate of Conformance (CC). He stated that the KSi system does not necessarily retain a heel. Most products pass through the KSi system completely, returning to a zero indication following the discharge of each repeated load from the weigh hopper when in automatic operation. Mr. Suiter noted there are scales used in automatic batching operations that are not considered ABWSs. He concluded it is not necessary that these systems record the no-load and loaded weight values providing the scales in these systems return to zero following discharge of the product from the weigh hopper.

The SMA supported the item and suggested the wording offered by the SWMA be used. The SMA also supported the addition of definitions for non-automatic and automatic batching systems.

Ms. Tina Butcher (OWM) provided a summary of OWM’s analysis of these items, which has been copied below and was made available to the NCWM membership during the Open Hearings of the S&T Committee.

**OWM Analysis of S&T Items 320-1, 324-1, 330-1, and 360-1:**

OWM considers Items 320-1, 324-1, and 330-1 companions to this item (360-1) and understands these first three items were submitted after it was made known to the submitter that definitions can only be added to NIST Handbook 44 to define terms appearing in one or more of the codes within the Handbook. That is, it is believed that Items 320-1, 324-1, and 330-1 were submitted as an afterthought because nowhere in the “Application” section of the Scales Code (Section 2.20.), Automatic Weighing Systems Code (Section 2.24.), or Liquid-Measuring Devices Code (Section 3.30.) of NIST Handbook 44 does the term “batching system” appear. The devices associated with these three codes are often components of batching systems. OWM presumes the submitter is proposing this term be included in each of these device codes to make clear that these codes are intended to apply to these devices when installed in a batching system and to help differentiate a batching system from an automatic bulk weighing system. The justification given for proposing a definition be added is that one state tried to categorize batching systems as automatic bulk weighing systems under NIST Handbook 44, Section 2.22. Automatic Bulk Weighing Systems Code.

Adding the term “batching system” to the “Application” section of each of these device codes when nowhere else within any of these codes is that term used is an inappropriate approach. It is not the batching system as a whole that typically gets inspected. The different devices used commercially in a batching system are examined independently of each other (and of the system) using the appropriate codes that apply to those devices (i.e., the General Code and whichever device code applies to the type of device being inspected as part of the batching system).

The proposed definition of “batching system” does not provide sufficient information to allow a conclusive distinction be made between a batching system and an ABWS. For example, nowhere in the definition does it specify that the commercial devices used in a batching system designed to automatically weigh commodities in successive drafts must start each draft (i.e., the first and each successive draft) from a zero-load balance condition (if a scale), yet this is a significant distinguishing factor between an ABWS and a scale used in a batching system designed to operate in automatic mode. For this reason, OWM does not believe that the addition of the definition being proposed will solve the problem that the submitter has identified; nor does OWM believe that a definition of “batching system” is needed.

OWM’s research into the history of the ABWS Code revealed the ABWS Code was first added to NIST Handbook 44 in 1984. It was developed by the U.S. Department of Agriculture (USDA) Federal Grain Inspection Service (FGIS) in consultation with OWM to recognize electronic grain weighing systems, which were becoming more prevalent at that time. Originally titled “Automatic Bulk Weighing Systems for Grain” the words “for Grain” were deleted from the title in 1987 to broaden the application of the code to include all ABWS.

In 1981 (three years prior to the code being added to NIST Handbook 44), the NCWM adopted five new principles relating to the design, operation, and testing of an ABWS that had been developed by USDA’s FGIS and OWM. Of notable mention, the first three principles (shown below) recognize that in order to weigh repeated drafts accurately, a no-load reference value must be indicated, recorded, and taken into account in the determination of the net load of *each* draft. In adopting these principles, the NCWM recognized that ABWS operate by weighing repeated drafts automatically (without intervention of an operator) and the net weight determination is made by calculating the difference between the no-load reference value and the value of each draft load.

1. No Load Reference – Although NIST Handbook 44 seems to require an indication of “zero” as a no load reference, the principle expressed is to weigh accurately it is necessary that a readily understandable, repeatable, and effective “no load reference” be indicated and recorded. Since automatic bulk weighing systems operate by weighing repeated drafts and the net weight determination is made by calculating the difference between the no load reference values and the values obtained with an equilibrium at specific loads, it is necessary only that the no load reference meet the previously mentioned criterion. A positive value seems to meet that criterion and additionally can be more accurate since the no load reference value is automatically determined and used in the calculation after every draft. Consequently, any change in the no load equilibrium condition does not require the intervention of an operator. Therefore, for this special equipment, paragraph S.I.1. Zero Indications, should be interpreted as requiring only an appropriate “no load reference” rather than a “zero” reference. Also, paragraph UR.4.1. Balance Condition, should be interpreted as requiring that the “no load” or “zero load reference be indicated and recorded.

2. Recorded Values. – It is necessary that these systems be equipped with recording elements since it is impractical and probably impossible to manually record the correct values in such a repeated operation. Other conditions necessary are:
  - a) an effective motion detect system consistent with the requirements of NIST Handbook 44 so that the values can be recorded only when the device is in stable equilibrium;
  - b) the values are displayed during the printing cycle;
  - c) some guarantee and indication that both gates (weigh hopper and loading garner) are closed during the print cycle;
  - d) the system shuts down automatically when it fails to operate in accord with its design;
  - e) some guarantee that a final partial draft quantity is recorded;
  - f) in direct sale applications a complete record of all recorded values is provided to the party not operating the equipment;
  - g) the values recorded are consistent with the requirements of G-S.5. (i.e., clear, definite and easily read under normal conditions of operation);
  - h) some guarantee that any test weights installed in the system cannot interfere with correct weighing; and
  - i) when the system is designed to transport grain through the scale without being weighed, means shall be provided to indicate clearly that this mode of operation is being utilized.
3. No Load Reference Sequence. – Since these systems are used both to “weigh in” and/or to “weigh out” the sequence in which the quantity received or quantity delivered is determined must be stipulated. When the quantity of product received is being determined, it is necessary that the “no load reference value” be determined and recorded first and the “full load reference value” determined and recorded next. Thus the difference is the amount received. Conversely, when the quantity of product delivered is being determined, the sequence must be reversed; that is, “full load reference” first, and “no load reference” next. If a system does not have this dual capability, it can be considered appropriate only for service consistent with its design.

OWM believes it is important that these same three principles listed above be applied today to systems that weigh a single bulk commodity in repeated, automatic drafts. This especially holds true for weighing any commodity where some residual product is likely to remain inside the load-receiving element (e.g., the hopper) after the discharge cycle has been completed. Certain types of products being weighed will inherently cling to the vessel in which they are contained, thus, preventing complete product discharge. There is no way to predict how much residual product will remain after each weighing/discharge cycle; that is, the amount will likely change with each discharged load and be reflected as a persistent change in the zero-load balance. The most accurate way to account for this remaining product is to require the no-load starting reference be recorded and taken into account in the calculation of each draft load. Zeroing the scale to account for these changes should not be considered an option because such action would result in inaccurate net weight determinations. That is, if residual product remains after a weighed load has been discharged and its weight then zeroed off before the next load to be weighed is added, any difference in the amount of residual product remaining after that next load is discharged will not be accounted for in the net weight of that load. For example, if 20 lb of residual product left remaining in a weigh hopper were zeroed off to start a new draft load and 1000 lb of product was then added to the hopper and weighed, a 10 lb weighing error would result if, when the load was discharged, 10 lb of residual product remained. When multiple draft loads are weighed to achieve some targeted load, such as is usually the case with ABWSs, zeroing the scale to account for zero-load balance changes at the start of each draft load will result in cumulative errors affecting the entire load. In such applications, an automatic bulk weighing system is required.

The remaining two principles adopted in 1981 relate to the proposals in a less significant degree, but are copied below for reference.

4. Other Design Considerations. – There are, of course, other design and operating characteristics that must be considered in determining the appropriateness of these systems. A check list has been developed by FGIS which is as complete as circumstances allow and this information will be included in the checklist developed for the National Type Approval Task Force as soon as possible.
5. Test Procedures. – The test of this equipment must follow the principles expressed in NIST Handbook 112; that is, “A precise operation based upon proven standards and so conducted as to duplicate, as nearly as practicable, service conditions of operation.”

It is the device application that differentiates a scale used in a batching system from one used in an ABWS and, therefore, determines the appropriate NIST Handbook 44 codes that apply. In a batching operation, more than one product is weighed and/or measured and mixed together to form a batch (hence the name). A batching system typically consists of weighing elements (e.g., one or more weigh hoppers) that facilitate multiple individual weighments of different ingredients that ultimately get mixed together to form a product mix (or recipe). The system may be comprised of one or more commercial weighing and/or measuring devices. Each new draft load must be initiated from a zero-load balance condition. That is, the weighing process for each draft of a targeted load must start with the weighing/load-receiving element empty and the scale indicating zero (i.e., a correct zero-load balance condition). The Scales Code and General Code apply to the scales used in a batching operation. In contrast, an ABWS weighs a single commodity in successive drafts of predetermined amounts and automatically records the no-load starting reference and loaded weight values, accumulating the net weight of each draft. The no-load starting reference for each draft is most oftentimes a value other than zero and must be recorded by the system (as required by the ABWS Code of NIST Handbook 44). Only when the application of the system is understood can a determination of type of device be made and the appropriate NIST Handbook 44 code applied.

A review of existing NTEP CCs for scale system controllers used in bulk weighing operations shows inconsistent terms used to identify them: Batching Controller; Bulkweighing System, Scale System Controller (Concrete/Asphalt Batching System Controller, Digital Electronic); etc. Coupled with information appearing in the “Application” portion of the CC leaves questionable whether some of these scale system controllers were evaluated for use in a batching operation, an ABWS operation, or both. Not knowing whether these inconsistencies might have been part of the reason, which ultimately led to this proposal, NTEP may wish to consider a review of existing CCs to determine whether additional information might be needed to identify the intended application(s) as well as providing additional guidance to the NTEP weighing evaluators regarding completion of future CCs.

The Committee agreed to Withdraw these items in consideration of the comments and analysis that were provided. In discussing the issue, the Committee agreed that residual product left remaining in a weigh hopper following the discharge of product that is weighed automatically in repeated drafts could cause significant error in the weighing result of the summed total for all drafts. In reaching its decision to Withdraw these items, the Committee considered the weighing application for which the proposals were intended to address. That is, the Committee considered the density and cost of the products (seeds) being weighed and their propensity to clinging to the sides of a hopper when being discharged after weighing. The Committee felt, in the case of some seeds, especially seed types that are lightweight, not all of the weighed seed would necessarily be discharged when the hopper is emptied following completion of a weighing cycle. This being the case, the Committee was concerned that significant weighing errors could result from automatic operation of the system. The Committee recognized there are some applications (e.g., the weighing of stone, etc.) in a batching operation where, due to the weight and physical characteristics of the product being weighed, there is a presumed likelihood that all product would be discharged from a hopper following completion of each weighing cycle. In such applications, the no-load reference would not need to be recorded since the scales being used in these applications would presumably start on zero at the start of each new draft load to be weighed. The Scales Code would apply to the scales used in these batching systems and officials could and should confirm as part of their official examination of the system, that the scales return to zero each time a load is discharged from the weigh hopper. (*NIST Technical Advisor’s Note: The Committee’s acknowledgement that the Scales Code would apply is in recognition of the following reminder appearing in Agenda Item 304-3 of the 1985 NCWM Final Report of the S&T Committee: “The Committee reminds the Conference that this code (i.e., the ABWS Code) does not apply to batching systems, for which the Scale Code applies.”*) The Committee also considered whether or not it



was appropriate to add the term “batching system” to various device codes in NIST Handbook 44 as proposed when there are no requirements in any of those codes that apply specifically to batching systems. The Committee saw no benefit to adding the term and was concerned that by doing so, it could lead to confusion.

An action suggested by the Committee is that NTEP review all existing CCs issued for a scale system controller to confirm the application(s) for which they were evaluated and ensure those applications are clearly specified on the CC.

**Regional Association Meetings:**

SWMA 2014 Annual Meeting: The SWMA did not hear any comments in opposition to this item during its 2014 Annual Meeting. The Committee revised the proposed language to clarify, but not change the intent. SWMA suggested that the NCWM S&T Committee may wish to consider merging Agenda Items 320-1; 324-1; 330-1; and 360-1 as they are all related. Comments were heard for all four of these agenda items at the same time. SWMA forwarded the item to NCWM recommending it as a Voting item as amended below.

**A.1. General.** – This code applies to all types of weighing devices, including non-automatic batching systems. This code does not apply to other than automatic bulk-weighing systems, belt-conveyor scales, and automatic weighing systems. The code comprises requirements that generally apply to all weighing devices, and specific requirements that are applicable only to certain types of weighing devices.

Additional letters, presentations, and data may have been part of the Committee’s consideration. To review the supporting documentation, please refer to the *Report of the 99<sup>th</sup> National Conference on Weights and Measures* (SP1193, 2014).

**320-2 VC T.N.3.5. Separate Main Elements.**

(This item was Adopted.)

**Source:**

Ohio NTEP Laboratory (2015)

**Purpose:**

Improve uniformity in how the tolerance is applied by providing clarification of the intent.

**Item Under Consideration:**

Amend NIST Handbook 44, Scales Code as follows:

**T.N.3.5. Separate Main Elements: Load Transmitting Element, Indicating Element, Etc.** – If a main element separate from a complete weighing device is submitted for laboratory type evaluation, the tolerance for the main element is 0.7 that for the complete weighing device. This fraction includes the tolerance attributable to the testing devices used.

**(Amended 2015)**

**Background/Discussion:**

The submitter wants to distinguish the difference between laboratory testing and field testing to eliminate any confusion as to what tolerance to apply. The word “laboratory” is not implied in the current wording. As worded, there are differences in opinions as to the intent on this paragraph. This proposal would improve uniformity in all NTEP evaluations. The Ohio NTEP Laboratory has held field evaluations to 0.7 tolerance in the past.

**2015 NCWM Interim Meeting:**

NCWM 2015 Interim Meeting: The Committee considered the following proposal intended to provide additional clarification regarding the application of Scales Code paragraph T.N.3.5. Separate Main Elements: Load Transmitting Element, Etc.:

**T.N.3.5. Separate Main Elements: Load Transmitting Element, Indicating Element, Etc.** – If a main element separate from a **complete** weighing device is submitted for **laboratory** type evaluation, the tolerance for the **main** element is 0.7 that for the complete weighing device. This fraction includes the tolerance attributable to the testing devices used.

The SMA supported this item but recommended the word “laboratory” be removed noting that type evaluations are performed both in the field and laboratory. Ms. Fran Elson-Houston (Ohio), submitter of the item, agreed with the removal of the word “laboratory” from the proposal.

In discussing this item, the Committee felt the proposed changes would help improve understanding of the paragraph, but also agreed that the word “laboratory” should be deleted from the proposal. Consequently, the Committee agreed to recommend this item for Vote absent the word “laboratory” as follows:

**T.N.3.5. Separate Main Elements: Load Transmitting Element, Indicating Element, Etc.** – If a main element separate from a **complete** weighing device is submitted for type evaluation, the tolerance for the **main** element is 0.7 that for the complete weighing device. This fraction includes the tolerance attributable to the testing devices used.

#### **2015 NCWM Annual Meeting:**

NCWM 2015 Annual Meeting: Ms. Elson-Houston recommended the word “laboratory” be reinserted into the proposal before the words “type evaluation.” She commented the reduced 0.7 tolerance is not intended to apply to type evaluations performed in the field. The reduced tolerance should only be applied in controlled laboratory environments. Mr. Russ Vires (Mettler-Toledo, LLC), Mr. Steve Langford (Cardinal Scale Manufacturing Co.), and Mr. Lou Straub (Fairbanks Scales) provided comments in support of reinserting the word “laboratory” back into the paragraph. Consequently, the Committee agreed to add the word “laboratory” into the proposal and recommend the item be presented for vote as shown in Item Under Consideration.

#### **Regional Association Meetings:**

CWMA 2014 Interim Meeting: The CWMA received comments in support of this item. The CWMA believes this item is sufficiently developed and forwarded the item to NCWM, recommending it as a Voting item. During the 2015 CWMA Annual Meeting, the item was supported by the SMA and the item submitter, Ms. Fran Elson-Houston (Ohio), who also recommended some proposed changes to the item. The CWMA agreed to amend the proposal as recommended by Ms. Houston and forward the item to NCWM, recommending it as a Voting item. CWMA agreed to amend the item to read as follows:

**T.N.3.5. Separate Main Elements: Load Transmitting Element, Indicating Element, Etc.** – If a main element separate from a **complete** weighing device is submitted for **laboratory** type evaluation, the tolerance for the **main** element is 0.7 that for the complete weighing device. This fraction includes the tolerance attributable to the testing devices used. **If there are no means to control environmental conditions, such as a field evaluation, full acceptance tolerance would be applied to the main element.**

WWMA 2014 Annual Meeting: The WWMA did not receive testimony on this item during the Annual Meeting. The WWMA S&T Committee reported it would like additional background information and questioned whether this item would be more suited to NCWM Publication 14 rather than NIST Handbook 44. WWMA forwarded this item to NCWM and recommended that it be an Informational item.

SWMA 2014 Annual Meeting: The SWMA did not hear any comments in opposition to this item during its Annual Meeting. SWMA forwarded the item to NCWM, recommending it as a Voting item.

NEWMA 2014 Interim Meeting: NEWMA reported it believed the justifications for the item have merit and agreed to forward the item to NCWM recommending that it be a Voting item. At its 2015 Annual Meeting, NEWMA agreed to recommend the item move forward as a Voting item noting the belief that the changes would improve understanding of the paragraph.

Additional letters, presentations, and data may have been part of the Committee’s consideration. To review the supporting documentation, please refer to the *Report of the 99<sup>th</sup> National Conference on Weights and Measures* (SP1193, 2014).

**320-3 W Table 7a. Typical Class or Type of Device for Weighing Applications**

(This item was Withdrawn.)

**Source:**

Ohio NTEP Laboratory (2015)

**Purpose:**

Require that hopper scales less than 2000 lb, which are not grain hoppers, be class III devices and allow “special devices” greater than 30 000 lb that are not vehicle scales and not currently listed under Class III L, to be categorized as Class III L.

**Item Under Consideration:**

Amend NIST Handbook 44 Scales Code as follows:

<b>Table 7a. Typical Class or Type of Device for Weighing Applications</b>	
<b>Class</b>	<b>Weighing Application or Scale Type</b>
I	Precision laboratory weighing
II	Laboratory weighing, precious metals and gem weighing, grain test scales
III	All commercial weighing not otherwise specified, grain test scales, retail precious metals and semi-precious gem weighing, grain-hopper scales, <b>other hopper scales under 2000 lb</b> , animal scales, postal scales, vehicle on-board weighing systems with a capacity less than or equal to 30 000 lb, and scales used to determine laundry charges
III L	Vehicle scales, vehicle on-board weighing systems <b>and other special devices</b> with a capacity greater than 30 000 lb, axle-load scales, livestock scales, railway track scales crane scales, and hopper (other than grain hopper) scales
IIII	Wheel-load weighers and portable axle-load weighers used for highway weight enforcement
<b>Note:</b> A scale with a higher accuracy class than that specified as “typical” may be used.	

(Amended 1985, 1986, 1987, 1988, 1992, 1995, and 2012)

**Background/Discussion:**

Many small hoppers that are not grain hoppers are already receiving CCs as Class III hoppers, which does not satisfy the categories in Table 7a. There are also a few large capacity floor scales that have to meet Class III tolerances that really don’t need that level of accuracy and would benefit from being categorized as a Class III L device.

**2015 NCWM Interim Meeting:**

The SMA opposed this item and provided the following rationale for its position: This item would unnecessarily restrict applications of hopper scales or devices with capacities greater than 30 000 lb.

An official questioned why 2000 lb was selected as the proposed threshold, as opposed to some other capacity value, such as 5000 lb, and the meaning of “other special devices.”

Ms. Fran Elson-Houston (Ohio) reported that “other special devices” is intended to address a particular scale of special design (i.e., a scale designed for use in weighing rolls of coil) that had been submitted to the Ohio NTEP lab.

OWM noted that Table 7a is not a requirement, but rather identifies typical classes of devices for weighing applications. The “Note” at the bottom of the table specifies that a scale with a higher accuracy class than that specified as “typical” may be used (“higher” meaning, a level higher in the table, with Class I being the highest, and Class III the lowest). Considering this point, the table provides scale manufacturers the necessary flexibility of being able to design and build scales of similar or same capacity, but with different levels of accuracy; this enables them to meet the demands of their customers by being able to supply them with scales suitable for many different weighing applications. With regard to the two sentences shown at the beginning of the “Background/Discussion” of this item, it is incorrect to say that a small hopper scale of Accuracy Class III does not meet Table 7b considering the explanation provided in the “Note” at the bottom of the table. While the second sentence may be true, scale manufacturers designate the accuracy class for scales they manufacture. Users are required to select a scale suitable for the application and officials verify that a proper scale has been selected based on its application. In some cases, users will select a scale with a higher accuracy class than what’s needed for the application. Doing so is not a violation, but rather provides scale owners the opportunity of being able to use a scale that is more accurate than what’s required or needed. For these reasons, OWM does not believe changes are needed to the table and making them could cause unnecessary confusion.

Members of the Committee were concerned the changes proposed might cause unnecessary confusion. In recognition of the fact that Table 7a is intended to identify typical classes of weighing devices and that the “note” in Table 7a makes it permissible for a scale with a higher accuracy class than that specified as “typical” to be used (e.g., the note makes it permissible for a hopper scale under 2000 lb capacity to be classified as a Class III device), the Committee agreed to Withdraw this item from its agenda.

#### **Regional Association Meetings:**

**CWMA 2014 Interim Meeting:** The CWMA reported that an industry representative suggested that the phrase “other special devices” needs clarification. It was then suggested the wording “other special devices” be changed to “other special application scales.” Another industry representative voiced support for this change because it gives the manufactures more latitude when designing devices. The CWMA forwarded the item to NCWM recommending it as a Voting item with the following change to the proposal: change the phrase, “other special devices” to “other devices” in the box for class III.

**WWMA 2014 Annual Meeting:** The WWMA did not receive comments on this item at its 2014 Annual Meeting. The WWMA S&T Committee would like to see further clarification of “other special devices.” Further, the Committee would like consideration to be given to including hopper scales with a capacity of less than 5000 lb to better align with other weighing devices in Class III. The WWMA forwarded this item to NCWM and recommended that it be a Developing item.

**SWMA 2014 Annual Meeting:** The SWMA questioned why the proposed limit was set at 2000 lb and not 5000 lb. The Committee noted it would appreciate the SMA’s comments concerning this question. The SWMA forwarded the item to NCWM, recommending it as a Voting item.

**NEWMA 2014 Interim Meeting:** NEWMA’s S&T Committee wanted more information on the proposal, such as whether there are hopper scales over 2000 lb to consider in this item? NEWMA forwarded the item to NCWM and recommended that it be an Information item.

Additional letters, presentations, and data may have been part of the Committee’s consideration. To review the supporting documentation, please refer to the *Report of the 99<sup>th</sup> National Conference on Weights and Measures* (SP1193, 2014).

### 320-4 VC Part 2.20. Weigh-In-Motion Vehicle Scales for Law Enforcement – Work Group

(This item was Adopted.)

**Source:**

NIST, OWM, Mr. Richard Harshman, on behalf of the U.S. Federal Highway Administration (FHWA) (2011)

**Purpose:**

To provide the U.S. Weights and Measures community (equipment manufacturers, weights and measures officials, truck weight enforcement officials, and other users) with legal metrology requirements to address WIM systems used for vehicle enforcement screening.

**Item Under Consideration:**

Adopt the proposed Section 2.25. Weigh-In-Motion Systems Used for Vehicle Enforcement Screening Code shown in Appendix C as a tentative code in Section 2 of NIST Handbook 44, and adopt the proposed definitions of terms used in the tentative code (also included in Appendix C) into NIST Handbook 44, Appendix D – Definitions.

**Background Discussion:**

The nation's highways, freight transportation system, and enforcement resources are being strained by the volume of freight being moved and the corresponding number of commercial vehicles operating on its roads. Traditional, static-based vehicle inspection activities simply cannot keep pace with anticipated truck volume increases. Current U.S. Department of Transportation (DOT) forecasts project freight volumes to double by 2035 and commercial vehicles to travel an additional 100 billion miles per year by 2020. WIM technology has been targeted by FHWA and Federal Motor Carrier Safety Administration (FMCSA) as a technology capable of supporting more effective and efficient truck weight enforcement programs.

Several DOT efforts are underway and planned for the future to maintain adequate levels of enforcement that ensure equity in the trucking industry market and protection of highway infrastructure. Judicial support for enforcement decisions to apply more intense enforcement actions on specific trucks depends on support from the U.S. legal metrology community. Standards are needed in NIST Handbook 44 to address the design, installation, accuracy, and use of WIM systems used in a screening/sorting application. The implementation of a uniform set of standards will greatly improve the overall efficiency of the nation's commercial vehicle enforcement process.

Once adopted by the truck weight enforcement community, these requirements will enhance the accuracy of the nation's WIM scale systems; serve as a sound basis for judicial support of next-generation truck weight enforcement programs; and result in fewer legally loaded vehicles being delayed at static weigh station locations, thus, reducing traffic congestion and non-productive fuel consumption and improving the movement of freight on our nation's roadways.

**Purpose of the Project:**

The FHWA's Office of Freight Management and Operations recognized a need to encourage uniformity in the design, testing, installation, and performance of WIM technology and subsequently encourage acceptance by prosecution agencies (administrative or judicial) regarding the validity of WIM technology's role in supporting commercial motor vehicle weight enforcement.

In response to this need and recognizing the value of having a standard included in NIST Handbook 44 because it lends integrity and is more recognizable in legal actions, the FHWA seeks to integrate requirements for WIM technology into the Handbook. The FHWA contracted the services of the Texas Transportation Institute of the Texas A&M University System and Battelle (a private company) to begin this process. Additionally, a small oversight Committee was formed by the FHWA made up of three representatives from the FHWA, NIST, and a U.S. manufacturer of WIM equipment to validate that each contract deliverable is completed according to contract. NIST, OWM also agreed to provide a Technical Advisor to the associated work group (WG) tasked with development of the proposed code.

The intended application of the proposed new code is for screening purposes only (i.e., for screening/sorting commercial vehicles for possible violations of vehicle weight requirements).

To view a detailed summary on the progress of this project since its inception in December 2011 through 2012, refer to “Timeline of Completed Tasks Relating to the Project” in S&T Agenda Item 360-3 in the Committee’s 2012 Final Report. Additional background information and information on the work is also included in that report.

Also see the Committee’s 2013 and 2014 Final Reports for additional details and background information relating to the development of a new NIST Handbook 44 device code applicable to weigh-in-motion systems used for vehicle enforcement screening.

#### **2015 NCWM Interim Meeting:**

NCWM 2015 Interim Meeting: Ms. Tina Butcher (OWM) thanked the WIM WG for providing fair consideration of OWM’s many comments, which were provided throughout the different revisions of the draft code. She noted that although the process of developing the draft code may have taken longer than some had originally anticipated, the additional time taken had proven to be of benefit because it allowed for greater discussion and understanding of some of the more complex issues concerning WIM systems. OWM believes the Work Group has presented a draft code that is ready to be adopted and placed into NIST Handbook 44 as a tentative code. OWM encouraged the use of the code, especially while in a tentative status, to help identify any remaining concerns. OWM also pointed out that the Section number designation “2.20.” prefacing the title of this item is incorrect. The proposal is to add a tentative code into Section 2 of NIST Handbook 44 and not Section 2.20.

Mr. Langford, speaking on behalf of the SMA, stated that the SMA continues to support the efforts of the WG and recommends a July Vote on the final draft of the code.

In consideration of the comments provided in support of the item, the Committee agreed to recommend it move forward for Vote.

#### **2015 NCWM Annual Meeting:**

NCWM 2015 Annual Meeting: The Committee heard several comments in support of adding a new tentative code titled “Weigh-In-Motion Systems Used for Vehicle Enforcement Screening Code” to NIST Handbook 44. Mr. Steve Langford (Cardinal Scale Manufacturing Co.) commented that he was a member of the FHWA Project Oversight Committee and, as such, commended the WIM WG for its great work in developing the code. He reported Cardinal Scale Manufacturing Co. manufactures in-motion vehicle scale systems and that the code is needed from a manufacturer’s standpoint. Mr. Lou Straub (Fairbanks Scales) also commented in support of adopting the draft as a tentative code.

Ms. Kristin Macey (California) voiced support for the code, but questioned how the tolerances in Section 2.2. of the draft code were determined. Mr. Darrell Flocken (NCWM and Chairman of the WIM WG) in answering her question indicated the tolerances were recommended by the WIM manufacturers participating on the WG. The WIM manufacturers already have WIM systems in operation and the tolerances in Section 2.2. were based on the accuracy that could be expected from them. Ms. Fran Elson-Houston (Ohio) also voiced support for the code.

Ms. Butcher stated that OWM encourages adoption of the draft as a tentative code. It includes the necessary components to:

- Improve uniformity and consistency in the inspection and testing of WIM vehicle scales used in law enforcement applications throughout the country;
- Reduce vehicles operating within legal load limits from being unnecessarily detained for static weighing; and
- Improve the flow of freight, a key reason for the code’s development.

Ms. Butcher noted that weights and measures agencies are not the only ones who will use this code. Federal, state, and local agencies responsible for highway weight enforcement, traffic monitoring, and pavement design will also use

the code. Some already use NIST Handbook 44 for static vehicle scales and are looking to include WIM requirements to provide the same credibility and uniformity as other NIST Handbook 44 requirements. OWM encourages these agencies to provide feedback on refinements needed as they begin using the code.

The Committee agreed to recommend the item be presented for Vote as shown in Item Under Consideration, hearing numerous comments in support of the proposal and no comments in opposition.

**Regional Association Meetings:**

**CWMA 2014 Interim Meeting:** The CWMA reported that a regulatory official commented that these devices may not be under Weights and Measures jurisdiction. CWMA forwarded the item to NCWM, recommending it as an Information item. During the 2015 CWMA Annual Meeting Open Hearings, the SMA, industry representatives, and officials voiced support of the proposal, and there were no comments made in opposition. Consequently, the CWMA agreed to recommend the item be forwarded to the NCWM as a Voting item.

**WWMA 2014 Annual Meeting:** Testimony was presented in support of this item moving forward as a Voting item and several felt that it is sufficiently developed. The WWMA supports this item and looks forward to it being presented on the 2015 NCWM Annual Meeting Agenda. WWMA recommends that this item be a Voting item.

**SWMA 2014 Annual Meeting:** The SWMA did not hear any comments in opposition to this item. The Committee recognizes the interest by the community to further develop this item and recommended that it be a Developing item.

**NEWMA 2014 Interim Meeting:** NEWMA received comment that new information will be forthcoming from the WIM group in January 2015; the Committee recommended that the item remain Developing. During NEWMA's 2015 Annual Meeting, the SMA supported the item, and there were no comments received in opposition. Consequently, NEWMA recommended the item move forward as a Voting item.

Additional letters, presentations, and data may have been part of the Committee's consideration. To review the supporting documentation, please refer to the *Report of the 99<sup>th</sup> National Conference on Weights and Measures* (SP1193, 2014).

## **321 BELT-CONVEYOR SCALE SYSTEMS**

### **321-1 VC A.1. General.**

(This item was Adopted.)

**Source:**

U.S. National Work Group on Belt-Conveyor Scales (2015)

**Purpose:**

Expand the application of the Belt-Conveyor Scale (BCS) Systems Code to include weigh-belt systems to ensure that they are held to proper standards.

**Item Under Consideration:**

Amend NIST Handbook 44, BCS Systems Code as follows:

**A.1. General.** – This code applies to belt-conveyor scale systems and weigh-belt systems used for the weighing of bulk materials

**(Amended 2015)**

**Background/Discussion:**

The USNWG for BSC has identified gaps in multiple locations within the NIST Handbook 44, BCS Systems Code that would not allow a typical “weigh-belt system” type of design to be appropriately covered by the requirements found in this code. The USNWG has developed a number of proposals to amend each of these requirements so that

weigh-belt systems will be in compliance with them. Paragraph A.1. is the first in this series of proposed changes. This proposed change expressly states that the NIST Handbook 44, BCS Systems Code will also apply to “weigh-belt systems.”

NIST Handbook 44, BCS Systems Code language that existed prior to 2001 provided an exemption for BCS systems designed and furnished by the manufacturer from requirements that concerned the details of installation of BCS systems. Generally, weigh-belt systems are designed and built by the manufacturer as a unit and are, therefore, less likely to be susceptible to malfunctions or operational defects directly caused by a variance from the manufacturer’s intended installation specifications. This is in contrast to BCS systems that are typically installed as separate components (conveyor, weighing system, belt loading system, speed sensor, etc.) within an existing conveyor system where the details of the installation for each component may greatly influence the performance of other components in the system. That language (which has since been deleted) is shown below:

**UR.2.2.1. For Scales Not Installed by the Manufacturer.** – Unless the scale is installed in a conveyor designed and furnished by the scale manufacturer or built to the scale manufacturer’s specifications, the conveyor shall comply with the following minimum requirements:

...\*

(Amended 1998)

\*The subparagraphs that followed, UR.2.2.1.(a) through (j), consisted of requirements addressing specific criteria related to design and installation of the conveyor system.

The deletion of the statement: “installed in a conveyor designed and furnished by the scale manufacturer or built to the scale manufacturer’s specifications” created a situation where all BCS systems that were covered by the NIST Handbook 44, BCS Code were to meet requirements that included: specific limitations on the location of conveyor components in relation to the weighing element; specific limits on the length of the conveyor; and the type of take-up device used in the system. Due to the design and construction of typical weigh-belt systems, this type of device was not able to comply with these requirements largely due to the size, placement, and location of components in a weigh-belt type of system and the distances required between those components and the weighing elements.

USNWG members have agreed that it is important not to impose prescriptive requirements, which may restrict innovation in the design of this type of device. Requirements that place limitations on the placement of components in a conveyor system in relation to the weighing device and to each other are viewed as being arbitrary and may be invalid if the design of a system is shown to operate within performance requirements regardless of the configuration of its components.

BCS manufacturers who are members of the USNWG reported a demand from various clients for relatively compact weigh-belt type of systems to be used as a commercial device. However, unless the NIST Handbook 44 BCS Code is amended to allow for their unique design characteristics, there was not an appropriate code in NIST Handbook 44 to apply to weigh-belt systems. The USNWG, therefore, has developed a number of proposed changes throughout the existing BCS Systems Code to adapt these requirements so that they may be applied to weigh-belt systems as well.

#### **2015 NCWM Interim Meeting:**

NCWM 2015 Interim Meeting: Agenda Items 321-1 through 321-8 were grouped together and comments taken simultaneously as the Committee considered them all related. Ms. Tina Butcher (OWM) spoke in support of this item. She stated that NIST Handbook 44 included certain exceptions for installations of BCS systems installed under close supervision and control of the scale system manufacturer (prior to 2001). Ms. Butcher went on to state that it would be appropriate to reinstate these exemptions for the weigh-belt systems, as recognized by this item and she concurred these items should be grouped together (with perhaps the exception being Item 321-6) and designated as Voting. Item 321-6 is different in that the item does not relate to the inclusion of the term “weigh-belt systems” into the BCS Systems Code of NIST Handbook 44. Mr. Steve Langford representing the Scale Manufacturer's Association stated the SMA had no position on these items.

In consideration of the comments provided the Committee agreed to recommend this item for Vote.



**2015 NCWM Annual Meeting:**

NCWM 2015 Annual Meeting: At the Open Hearings, the Committee announced it was grouping Agenda Items 321-1 through 321-8 together and taking comments on all simultaneously.

Mr. Russ Vires (Mettler-Toledo, LLC) speaking on behalf of the SMA reported the SMA supports the Committee's grouping of the items and supports all of the items in the group.

Ms. Butcher noted that Item 321-6 doesn't fall under the same umbrella as the other items in the batch because, unlike the other items, it is not related to the inclusion of "weigh belts" into the BCS Systems Code; however, OWM would still support grouping all the items together. She also thanked the Committee for accepting OWM's changes to Item 321-6 and explained that the USNWG on BCSs had concurred with OWM's proposed changes to this item following the 2015 NCWM Interim Meeting.

Hearing no comments in opposition and in consideration that these items were developed and being recommended by the USNWG on BCSs, the Committee agreed to present Items 321-1 through 321-8 for Vote, each without change as shown in Item Under Consideration.

**Regional Association Meetings:**

CWMA 2014 Interim Meeting: The CWMA received a comment from a regulatory official who agreed with the necessity of this requirement. The CWMA appreciates the efforts of the WG and believes this item is sufficiently developed. The CWMA forwarded the item to NCWM, recommending it as a Voting item. At the 2015 CWMA Annual Meeting, the CWMA recommended the item be forwarded to the NCWM as a Voting item since there were no opposing comments and the item was supported by the SMA.

WWMA 2014 Annual Meeting: Testimony was presented in support of this item and moving it to a Voting status. The WWMA S&T Committee agreed that it was sufficiently developed and recommended that 2014 WWMA S&T Agenda Items 321-1, 321-2, 321-3, 321-4, 321-5, 321-6, 321-7, and 321-8 be combined into one proposal. The WWMA agreed and forwarded this item to NCWM and recommended that it be a Voting item.

SWMA 2014 Annual Meeting: The SWMA recommended Items 321-1 through 321-8 be combined into one agenda item since they are all related to BCS. Comments were heard on all eight of these agenda items at the same time. The SMWA forwarded this item to the NCWM and recommended that it be a Voting item.

NEWMA 2014 Interim Meeting: NEWMA supported the recommendations of the USNWG on BCSs since the majority of these devices are located outside of the northeast region. NEWMA forwarded the item to the NCWM and recommended that it be a Voting item. During the 2015 NEWMA Annual Meeting, NEWMA's S&T Committee agreed to group together Agenda Items 321-1 through 321-8 and take comments simultaneously. The SMA supported all items in the group. NEWMA agreed to recommend all items in the group move forward as Voting items.

Additional letters, presentations, and data may have been part of the Committee's consideration. To review the supporting documentation, please refer to the *Report of the 99<sup>th</sup> National Conference on Weights and Measures* (SP1193, 2014).

**321-2 VC S.4. Marking Requirements.**

(This item was Adopted.)

**Source:**

U.S. National Work Group on Belt-Conveyor Scales (BCS) (2015)

**Purpose:**

Add "weigh-belt systems" to the code and also create a new marking requirement to provide an accurate representation of the actual belt speed on systems that may operate at more than one speed. This information is needed to ensure that the system is operated within limitations of its ability to maintain accuracy and for testing purposes.

**Item Under Consideration:**

Amend NIST Handbook 44, BCS Systems Code as follows:

**S.4. Marking Requirements.** – ~~A-b~~**Belt-conveyor scales and weigh-belt systems** shall be marked with the following: (Also see also G-S.1. Identification.)

- (a) the rated capacity in units of weight per hour (minimum and maximum);
- (b) the value of the scale division;
- (c) the belt speed in terms of feet (or meters) per minute at which the belt will deliver the rated capacity, or the maximum and minimum belt speeds at which the conveyor system will be operated for variable speed belts;
- (d) the load in terms of pounds per foot or kilograms per meter (determined by materials tests); and
- (e) *the operational temperature range if other than – 10 °C to 40 °C (14 °F to 104 °F).*  
[Nonretroactive as of January 1, 1986]

**(Amended 2015)****Background/Discussion:**

Many belt-conveyor type of scale systems have the capability to operate at more than one belt speed setting or have the ability to operate using a variable belt speed. Since the weighing operation in a BCS system is dependent upon the belt speed (as a critical performance factor), it is important that the speed at which the belt travels be accounted for during an evaluation of the system. Changes in the speed of belt travel can result in significant changes to the performance of the weighing system, therefore, the requirement for the marking of belt speed on the device is significant.

In spite of the maximum capacity for which a conveyor system is designed, belt speed at which the system will be operated will be primarily determined by characteristics of components that comprise the entire system. Generally, the belt speed will be adjusted to a maximum setting that will permit optimal output of the system, but also so that the individual components in the system are not overloaded with the flow of material. In addition, on systems where different materials are weighed, the belt speed may be adjusted to accommodate the physical characteristics of different types of materials. Therefore, the speed setting at which the conveyor belt is operated at may vary in accordance with these considerations and the USNWG on BCSs agreed that this variation should be reflected in the marking of the belt speed(s) which will be used.

NIST Handbook 44, BCS Systems Code language that existed prior to 2001 provided an exemption for BCS systems designed and furnished by the manufacturer from requirements that concerned the details of installation of BCS systems. Generally, weigh-belt systems are designed and built by the manufacturer as a unit and are, therefore, less likely to be susceptible to malfunctions or operational defects directly caused by a variance from the manufacturer's intended installation specifications. This is in contrast to BCS systems that are typically installed as separate components (conveyor, weighing system, belt loading system, speed sensor, etc.) within an existing conveyor system where the details of the installation for each component may greatly influence the performance of other components in the system. That language which has since been deleted is shown below:

**UR.2.2.1. For Scales Not Installed by the Manufacturer.** – Unless the scale is installed in a conveyor designed and furnished by the scale manufacturer or built to the scale manufacturer's specifications, the conveyor shall comply with the following minimum requirements:

...\*

(Amended 1998)

\*The subparagraphs that followed, UR.2.2.1.(a) through (j), consisted of requirements addressing specific criteria related to design and installation of the conveyor system.

The deletion of the statement: "installed in a conveyor designed and furnished by the scale manufacturer or built to the scale manufacturer's specifications" created a situation where all BCS systems that were covered by the NIST

Handbook 44, BCS Code were to meet requirements that included specific limitations on the location of conveyor components in relation to the weighing element; specific limits on the length of the conveyor; and the type of take-up device used in the system. Due to their typical design and construction, weigh-belt systems were generally not able to comply with these requirements; this was largely due to the size, placement, and location of components in a weigh-belt type of system and the distances required between those components and the weighing elements.

The USNWG members have agreed that it is important not to impose prescriptive requirements, which may restrict innovation in the design of this type of device. Requirements that place limitations on the placement of components in a conveyor system in relation to the weighing device and to each other are viewed as being arbitrary and may be invalid if the design of a system is shown to operate within performance requirements regardless of the configuration of its components.

BCS manufacturers who are members of the USNWG reported a demand from various clients for relatively compact weigh-belt type of systems to be used as a commercial device. However, unless the NIST Handbook 44, BCS Code is amended to allow for their unique design characteristics, there was not an appropriate code in NIST Handbook 44 to apply to weigh-belt systems. Therefore, the USNWG has developed a number of proposed changes throughout the existing BCS Systems Code to adapt these requirements so that they may be applied to weigh-belt systems as well.

**2015 NCWM Interim Meeting:**

NCWM 2015 Interim Meeting: Agenda Items 321-1 through 321-8 were grouped together and comments taken simultaneously as the Committee considered them all related. Ms. Tina Butcher (OWM) spoke in support of this item. She stated that NIST Handbook 44 included certain exceptions for installations of BCS systems installed under close supervision and control of the scale system manufacturer (prior to 2001). Ms. Butcher went on to state that OWM believes it would be appropriate to reinstate these exemptions for the weigh-belt systems as recognized by this item and concurs that these items should be grouped together (with perhaps the exception being Item 321-6) and designated as Voting. Item 321-6 is different in that the item does not relate to the inclusion of the term “weigh-belt systems” into the BCS Systems Code of NIST Handbook 44. Mr. Steve Langford representing the Scale Manufacturer's Association stated the SMA had no position on these items.

In consideration of the comments provided, the Committee agreed to recommend this item for Vote.

**NCWM 2015 Annual Meeting:**

NCWM 2015 Annual Meeting: At the Open Hearings, the Committee grouped Agenda Items 321-1 through 321-8 together and took comments on all simultaneously. See Agenda Item 321-1 for a summary of the comments heard on these items.

Hearing no comments in opposition and in consideration that these items were developed and being recommended by the USNWG on BCSs, the Committee agreed to present Items 321-1 through 321-8 for Vote, each without change as shown in Item Under Consideration.

**Regional Association Meetings:**

CWMA 2014 Interim Meeting: The CWMA received a comment during the Interim Meeting from a regulatory official who agreed with the necessity of this requirement. The CWMA appreciates the efforts of the WG and believes this item is sufficiently developed. The CWMA forwarded the item to the NCWM, recommending it as a Voting item. At its 2015 Annual Meeting, the CWMA recommended the item be forwarded to the NCWM as a Voting item since there were no opposing comments and the item was supported by the SMA.

WWMA 2014 Annual Meeting: Testimony was presented in support of this item and moving it to a Voting Status. The WWMA S&T Committee agreed that it was sufficiently developed and recommended that 2014 WWMA S&T Agenda Items 321-1, 321-2, 321-3, 321-4, 321-5, 321-6, 321-7, and 321-8 be combined into one proposal. The WWMA forwarded this item to NCWM and recommended that it be a Voting item.

SWMA 2014 Annual Meeting: The SWMA recommended, at its Annual Meeting, Items 321-1 through 321-8 be combined into one agenda item since they are all related to BCSs. Comments were heard on all eight of these agenda items at the same time. The SMWA forwarded this tem to the NCWM and recommended that it be a Voting item.

NEWMA 2014 Interim Meeting: NEWMA supported the recommendations of the USNWG on BCSs since the majority of these devices are located outside of the northeast region. NEWMA forwarded the item to the NCWM and recommended that it be a Voting item. During the 2015 NEWMA Annual Meeting, NEWMA's S&T Committee grouped together Agenda Items 321-1 through 321-8 and took comments simultaneously. The SMA supported all items in the group. NEWMA agreed to recommend all items in the group move forward as Voting items.

Additional letters, presentations, and data may have been part of the Committee's consideration. To review the supporting documentation, please refer to the *Report of the 99<sup>th</sup> National Conference on Weights and Measures* (SP1193, 2014).

### 321-3 VC N.2.1. Initial Verification.

(This item was Adopted.)

**Source:**

U.S. National Work Group on Belt-Conveyor Scales (BCS) (2015)

**Purpose:**

Include "weigh-belt systems" in the test note. Also, clearly identify how many tests are to be performed and the specific settings at which they will be conducted. Provide specific testing guidance according to the configuration of the system and to clarify the required procedures.

**Item Under Consideration:**

Amend NIST Handbook 44, BCS Systems Code as follows:

**N.2.1. Initial Verification.** – A belt-conveyor scale system or a weigh-belt system shall be ~~verified with tested using~~ a minimum of two test runs performed at each ~~of the following flow rates: setting for belt speed/belt loading as indicated in Table N.2.1.~~

- ~~(a) normal use flow rate;~~
- ~~(b) 35 % of the maximum rated capacity; and~~
- ~~(c) an intermediate flow rate between these two points.~~

Results of the individual test runs in each pair of tests shall not differ by more than the absolute value of the tolerance as specified in T.2. Tolerance Values, Repeatability Tests. All tests shall be within the tolerance as specified in T.1. Tolerance Values.

Test runs may also be conducted at any other rate of flow that may be used at the installation. A minimum of four test runs may be conducted at only one flow rate if evidence is provided that the system is used at a single flow rate constant speed/constant loading setting and that rate does not vary in either direction by an amount more than 10 % of the normal flow rate that can be developed at the installation for at least 80 % of the time.

**Table N.2.1.**  
**Initial Verification**

<b><u>Device Configuration</u></b>	<b><u>Minimum of Two Test Runs at Each of the Following Settings</u></b>	<b><u>Total Tests (Minimum)</u></b>
<b><u>Constant belt speed/Variable loading</u></b>	<ul style="list-style-type: none"> <li>– <b><u>belt loading: high (normal)</u></b></li> <li>– <b><u>belt loading: medium (intermediate)</u></b></li> <li>– <b><u>belt loading: low (35 %)</u></b></li> </ul>	<b><u>6</u></b>
<b><u>Variable belt speed/Constant loading</u></b>	<ul style="list-style-type: none"> <li>– <b><u>belt speed: maximum</u></b></li> <li>– <b><u>belt speed: medium</u></b></li> <li>– <b><u>belt speed: minimum</u></b></li> </ul>	<b><u>6</u></b>
<b><u>Variable belt speed/Variable loading</u></b>	<ul style="list-style-type: none"> <li>– <b><u>speed: maximum/belt loading: high (normal)</u></b></li> <li>– <b><u>speed: maximum/belt loading: medium (intermediate)</u></b></li> <li>– <b><u>speed: maximum/belt loading: low (35 %)</u></b></li> <li>– <b><u>speed: minimum/belt loading: high (normal)</u></b></li> <li>– <b><u>speed: minimum/belt loading: medium (intermediate)</u></b></li> <li>– <b><u>speed: minimum/belt loading: low (35 %)</u></b></li> </ul>	<b><u>12</u></b>
<p><b><u>Use the device configurations in the left-hand column to identify the scale being tested.</u></b></p> <p><b><u>Perform two test runs (minimum) at each of the settings shown in the center column.</u></b></p> <p><b><u>The following terminology applies:</u></b></p> <ul style="list-style-type: none"> <li>• <b><u>High: maximum (normal use) operational rate.</u></b></li> <li>• <b><u>Low: 35 % of the maximum rated capacity of the system.</u></b></li> <li>• <b><u>Medium: an intermediate rate between the high and low settings.</u></b></li> </ul>		

(Table Added 2015)

(Added 2004) (Amended 2009 and 2015)

#### **Background/Discussion:**

Existing paragraph N.2.1. specifically references “BCS system” in the opening sentence, but does not mention “weigh-belt systems.” The USNWG on BCSs agreed that given this omission of the term “weigh-belt system,” this type of system would be excluded from the NIST Handbook 44, BCS Systems Code. The proposed changes, therefore, include the addition of “weigh-belt systems” in this sentence.

In addition, the current language used in N.2.1. does not take into consideration that on some conveyor systems there can be two separate means to adjust the rate of product flow across the weighing device. The flow of material onto the belt may be increased at the loading point, which will result in a higher weight per unit of belt length. This may result in an increased rate of material flow across the weighing device, or the speed of belt travel may simply be increased, which will also result in an increase of material flow rate.

At its February 2014 meeting, the USNWG on BCSs reached a consensus that testing should include the variation of product flow through the adjustment of: 1) the rate at which the material is loaded on to the belt and 2) the belt speed, where the system has a means for such adjustment. The existing language does not provide specific instruction needed to adequately evaluate systems that may normally operate at more than one belt speed and are equipped with means

to adjust the flow of material by either adjusting the speed of the belt or the flow of material at the loading point on the belt.

The proposed amendments to N.2.1. and the accompanying Table N.2.1. will clearly identify how many tests are to be performed and at what specific settings they will be conducted. These proposed changes are intended to provide specific testing guidance according to the configuration of the system and to clarify the required procedures.

NIST Handbook 44, BCS Systems Code language that existed prior to 2001 provided an exemption for BCS systems designed and furnished by the manufacturer from requirements that concerned the details of installation of BCS systems. Generally, weigh-belt systems are designed and built by the manufacturer as a unit and are, therefore, less likely to be susceptible to malfunctions or operational defects directly caused by a variance from the manufacturer's intended installation specifications. This is in contrast to BCS systems that are typically installed as separate components (conveyor, weighing system, belt loading system, speed sensor, etc.) within an existing conveyor system where the details of the installation for each component may greatly influence the performance of other components in the system. That language which has since been deleted is shown below:

**UR.2.2.1. For Scales Not Installed by the Manufacturer.** – Unless the scale is installed in a conveyor designed and furnished by the scale manufacturer or built to the scale manufacturer's specifications, the conveyor shall comply with the following minimum requirements:

...\*

(Amended 1998)

\*The subparagraphs that followed, UR.2.2.1.(a) through (j), consisted of requirements addressing specific criteria related to design and installation of the conveyor system.

The deletion of the statement: "installed in a conveyor designed and furnished by the scale manufacturer or built to the scale manufacturer's specifications" created a situation where all BCS systems that were covered by the NIST Handbook 44, BCS Code were to meet requirements that included: specific limitations on the location of conveyor components in relation to the weighing element; specific limits on the length of the conveyor; and the type of take-up device used in the system. Due to their typical design and construction, weigh-belt systems were not generally able to comply with these requirements; this was largely due to the size, placement, and location of components in a weigh-belt type of system and the distances required between those components and the weighing elements.

USNWG members have agreed it is important not to impose prescriptive requirements, which may restrict innovation in the design of this type of device. Requirements that place limitations on the placement of components in a conveyor system in relation to the weighing device and to each other are viewed as being arbitrary and may be invalid if the design of a system is shown to operate within performance requirements regardless of the configuration of its components.

BCS manufacturers who are members of the USNWG reported a demand from various clients for relatively compact weigh-belt type of systems to be used as a commercial device. However, unless the NIST Handbook 44, BCS Code is amended to allow for their unique design characteristics, there was not an appropriate code in NIST Handbook 44 to apply to weigh-belt systems. Therefore, the USNWG has developed a number of proposed changes throughout the existing BCS Systems Code to adapt these requirements so that they may be applied to weigh-belt systems as well.

#### **2015 NCWM Interim Meeting:**

NCWM 2015 Interim Meeting: Agenda Items 321-1 through 321-8 were grouped together and comments taken simultaneously since the Committee considered them all related. Ms. Tina Butcher (OWM) spoke in support of this item. She stated that NIST Handbook 44 included certain exceptions for installations of BCS systems installed under close supervision and control of the scale system manufacturer (prior to 2001). Ms. Butcher went on to state that OWM believes it would be appropriate to reinstate these exemptions for the weigh-belt systems, as proposed by this item. She concurred these items should be grouped together (with perhaps the exception of Item 321-6) and designated as Voting; however, she noted that Item 321-6 is different in that the item does not relate to the addition of the term "weigh-belt systems" into the BCS Systems Code of NIST Handbook 44. Mr. Steve Langford representing the Scale Manufacturer's Association stated the SMA had no position on these items.

In consideration of the comments provided the Committee agreed to recommend this item for a Vote.

**2015 NCWM Annual Meeting:**

NCWM 2015 Annual Meeting: Open Hearings, the Committee announced it was grouping Agenda Items 321-1 through 321-8 together and taking comments on all simultaneously. See Agenda Item 321-1 for a summary of the comments heard on these items.

Hearing no comments in opposition and in consideration that these items were developed and recommended by the USNWG on BCSs, the Committee agreed to present Items 321-1 through 321-8 for Vote, each without change as shown in the Item Under Consideration.

**Regional Association Meetings:**

Interim 2014 Meeting: The CWMA received a comment from a regulatory official who agreed with the necessity of this requirement. The CWMA appreciates the efforts of the WG and believes this item is sufficiently developed. The CWMA forwarded the item to the NCWM, recommending it as a Voting item. At the 2015 CWMA Annual Meeting, the CWMA recommended the item be forwarded to NCWM as a Voting item since there were no opposing comments and the item was supported by the SMA.

WWMA 2014 Annual Meeting: Testimony was presented in support of this item and moving it to a Voting status. The WWMA S&T Committee agreed that it was sufficiently developed and recommended that 2014 WWMA S&T Agenda Items 321-1, 321-2, 321-3, 321-4, 321-5, 321-6, 321-7, and 321-8 be combined into one proposal. The WWMA forwarded this item to NCWM and recommended that it be a Voting item.

SWMA 2014 Annual Meeting: The SWMA recommended Items 321-1 through 321-8 be combined into one agenda item since they are all related to BCSs. Comments were heard on all eight of these agenda items at the same time. The SMWA forwarded this item to the NCWM and recommended that it be a Voting item.

NEWMA Interim 2014 Meeting: NEWMA supported the recommendations of the USNWG on BCSs since the majority of these devices are located outside of the northeast region. NEWMA forwarded the item to the NCWM and recommended that it be a Voting item. During the 2015 NEWMA Annual Meeting, NEWMA's S&T Committee agreed to group together Agenda Items 321-1 through 321-8 and take comments simultaneously. The SMA supported all items in the group. NEWMA agreed to recommend all items in the group move forward as Voting items.

Additional letters, presentations, and data may have been part of the Committee's consideration. To review the supporting documentation, please refer to the *Report of the 99<sup>th</sup> National Conference on Weights and Measures* (SP1193, 2014).

**321-4 VC N.2.3. Minimum Test Load.**

(This item was Adopted.)

**Source:**

U.S. National Work Group on Belt-Conveyor Scales (BCSs) (2015)

**Purpose:**

Add the appropriate minimum test load for weigh-belt systems that are being proposed to be included in this code under a separate proposal.

**Item Under Consideration:**

Amend NIST Handbook 44, Belt-Conveyor Scale (BCS) System Code as follows:

**N.2.3. Minimum Test Load.**

**N.2.3.1. Minimum Test Load, Weigh-Belt Systems. – The minimum test load shall not be less than the largest of the following values.**

**(a) 800 scale divisions;**

(b) **the load obtained at maximum flow rate in one revolution of the belt; or**

(c) **at least one minute of operation.**

**(Amended 2015)**

**N.2.3.2. Minimum Test Load, All Other Belt-Conveyor Scale Systems.** – Except for applications where a normal weighment is less than 10 minutes, the minimum test load shall not be less than the largest of the following values.

- (a) 800 scale divisions;
- (b) the load obtained at maximum flow rate in one revolution of the belt; or
- (c) at least 10 minutes of operation.

For applications where a normal weighment is less than 10 minutes (e.g., belt-conveyor scale systems used exclusively to issue net weights for material conveyed by individual vehicles and railway track cars) the minimum test load shall be the normal weighment that also complies with **N.2.3.2.**(a) and (b).

The official with statutory authority may determine that a smaller minimum totalized load down to 2 % of the load totalized in 1 hour at the maximum flow rate may be used for subsequent tests, provided that:

1. the smaller minimum totalized load is greater than the quantities specified in **N.2.3.2.** (a) and (b); and
2. consecutive official testing with the minimum totalized loads described in **N.2.3.2.** (a), (b), or (c) and the smaller minimum test load has been conducted that demonstrates the system complies with applicable tolerances for repeatability, acceptance, and maintenance.

(Added 2004) (Amended 2008 **and 2015**)

**Background/Discussion:**

Since the typical design of weigh-belt systems (see the Committee’s proposal to add a new definition for “weigh-belt systems” in NIST Handbook 44, Appendix D) consists of significantly shorter conveyors compared to those normally found in BCS systems, the time needed for a complete revolution of the belt to occur on a weigh-belt system is much shorter. The USNWG on BCSs agreed, due to the generally shorter time needed for a belt revolution on a weigh-belt system, the dynamics of the weigh-belt system could be evaluated without the need of an extended (10 min) period of operation as is required for a BCS system. The USNWG concluded that the weigh-belt systems could be sufficiently evaluated over a shorter time span and recommended that, as a minimum, one minute of operation would suffice.

Longer periods of operation of a belt-conveyor or weigh-belt system during a test will provide more time in which the effects of extreme low and high points of belt loading would be mitigated since these highs and lows are averaged into the total load. The high and low points of the belt loading would be seen during the start-up of the conveyor when material is just beginning to be loaded on the belt and then when the flow of material is cut off at the end of a “run” where a gradual decrease of material on the belt occurs. These extremes of belt loading would comprise a larger proportion of the total load during shorter periods of operation and could expose errors caused by inconsistent belt loading or other problems within the system. Thus, a test comprised of a shorter duration could be interpreted as being more stringent than one of a longer duration.

NIST Handbook 44, BCS Systems Code language that existed prior to 2001 provided an exemption for BCS scale systems designed and furnished by the manufacturer from requirements that concerned the details of installation of BCS systems. Generally, weigh-belt systems are designed and built by the manufacturer as a unit and are, therefore, less likely to be susceptible to malfunctions or operational defects directly caused by a variance from the manufacturer’s intended installation specifications. This is in contrast to BCS systems that are typically installed as separate components (conveyor, weighing system, belt loading system, speed sensor, etc.) within an existing conveyor



system where the details of the installation for each component may greatly influence the performance of other components in the system. That language, which has since been deleted, is shown below:

**UR.2.2.1. For Scales Not Installed by the Manufacturer.** – Unless the scale is installed in a conveyor designed and furnished by the scale manufacturer or built to the scale manufacturer’s specifications, the conveyor shall comply with the following minimum requirements:

...\*

(Amended 1998)

\*The subparagraphs that followed, UR.2.2.1.(a) through (j), consisted of requirements addressing specific criteria related to design and installation of the conveyor system.

The deletion of the statement: “installed in a conveyor designed and furnished by the scale manufacturer or built to the scale manufacturer’s specifications” created a situation where all BCS systems that were covered by the NIST Handbook 44, BCS Code were to meet requirements that included specific limitations on the location of conveyor components in relation to the weighing element; specific limits on the length of the conveyor; and the type of take-up device used in the system. Due to their typical design and construction, weigh-belt systems were not generally able to comply with these requirements; this was largely due to the size, placement, and location of components in a weigh-belt type of system and the distances required between those components and the weighing elements.

USNWG members have agreed that it is important not to impose prescriptive requirements, which may restrict innovation in the design of this type of device. Requirements that place limitations on the placement of components in a conveyor system in relation to the weighing device and to each other are viewed as being arbitrary and may be invalid if the design of a system is shown to operate within performance requirements regardless of the configuration of its components.

BCS manufacturers who are members of the USNWG reported a demand from various clients for relatively compact weigh-belt type of systems to be used as a commercial device. However, unless the NIST Handbook 44, BCS Code is amended to allow for their unique design characteristics, there was not an appropriate code in NIST Handbook 44 to apply to weigh-belt systems. Therefore, the USNWG has developed a number of proposed changes throughout the existing BCS Systems Code to adapt these requirements so that they may be applied to weigh-belt systems as well.

#### **2015 NCWM Interim Meeting:**

NCWM 2015 Interim Meeting: Agenda Items 321-1 through 321-8 were grouped together and comments taken simultaneously since the Committee considered them all related. Ms. Tina Butcher (OWM) spoke in support of this item. She stated that NIST Handbook 44 included certain exceptions for installations of BCS systems installed under close supervision and control of the scale system manufacturer (prior to 2001). Ms. Butcher went on to state that OWM believes it would be appropriate to reinstate these exemptions for the weigh-belt systems, as proposed by this item. She concurred these items should be grouped together (with perhaps the exception of Item 321-6) and designated as Voting; however, she noted that Item 321-6 is different in that the item does not relate to the addition of the term “weigh-belt systems” into the BCS Systems Code of NIST Handbook 44. Mr. Steve Langford representing the Scale Manufacturer’s Association (SMA) stated the SMA had no position on these items.

The Committee concluded that the alternative language provided by OWM is more appropriate and agreed to replace the submitter’s original proposed language (shown below) with the alternative language developed by OWM as shown in “Item Under Consideration.” The Committee then agreed to recommend this item for Vote.

**N.2.3. Minimum Test Load.** – Except for applications where a normal weighment is less than 10 minutes, the minimum test load shall not be less than the largest of the following values.

- (a) 800 scale divisions;
- (b) the load obtained at maximum flow rate in one revolution of the belt; or
- (c) at least 10 minutes of operation **for belt-conveyor scale systems or, for weigh-belt systems only, at least 1 min of operation.**

**2015 NCWM Annual Meeting:**

NCWM 2015 Annual Meeting Open Hearings: The Committee announced it was grouping Agenda Items 321-1 through 321-8 together and taking comments on all simultaneously. See Agenda Item 321-1 for a summary of the comments heard on these items.

Hearing no comments in opposition and in consideration that these items were developed and recommended by the USNWG on BCSs, the Committee agreed to present Items 321-1 through 321-8 for Vote, each without change as shown in the “Item Under Consideration.”

**Regional Association Meetings:**

CWMA 2014 Interim Meeting: The reported that a regulatory official questioned the one-minute requirement. It was suggested that the one-minute operational time proposed in paragraph N.2.3.(c) for weigh-belt systems was to warm the belt prior to testing. The CWMA appreciates the efforts of the WG and believes this item is sufficiently developed. The CWMA forwarded the item to the NCWM, recommending it as a Voting item. At the 2015 CWMA Annual Meeting, the CWMA recommended the item be forwarded to the NCWM as a Voting item since there were no opposing comments and the item was supported by the SMA.

WWMA 2014 Annual Meeting: Testimony was presented in support of this item and moving it to a Voting status. The WWMA S&T Committee agreed that it was developed and recommended that 2014 WWMA S&T Agenda Items 321-1, 321-2, 321-3, 321-4, 321-5, 321-6, 321-7, and 321-8 be combined into one proposal. The WWMA forwarded this item to the NCWM and recommended that it be a Voting item.

SWMA Annual 2014 Meeting: The SWMA recommended Items 321-1 through 321-8 be combined into one agenda item since they are all related to BCSs. Comments were heard on all eight of these agenda items at the same time. The SMWA forwarded this tem to the NCWM and recommended that it be a Voting item.

NEWMA 2014 Interim Meeting: NEWMA supported the recommendations of the USNWG on BCSs since the majority of these devices are located outside of the northeast region. NEWMA forwarded the item to the NCWM and recommended that it be a Voting item. During the 2015 NEWMA Annual Meeting, NEWMA’s S&T Committee agreed to group together Agenda Items 321-1 through 321-8 and take comments simultaneously. The SMA supported all items in the group. NEWMA agreed to recommend all items in the group move forward as Voting items.

Additional letters, presentations, and data may have been part of the Committee’s consideration. To review the supporting documentation, please refer to the *Report of the 99<sup>th</sup> National Conference on Weights and Measures* (SP1193, 2014).

**321-5 VC N.3.1.1. Determination of Zero.**

(This item was Adopted.)

**Source:**

U.S. National Work Group on Belt-Conveyor Scales (BCSs) (2015)

**Purpose:**

Segregating the requirements for BCSs that use electronic integrators from those that use mechanical integrators and add weigh-belt systems to the code.

**Item Under Consideration:**

Amend NIST Handbook 44, BCS Code as follows:

**N.3.1.1. Determination of Zero.** – A zero-load test is a determination of the error in zero, expressed as an internal reference, a percentage of the full-scale capacity, or a change in a totalized load over a whole number of complete belt revolutions. ~~For belt conveyor scales with electronic integrators, the test must be performed over a period of at least three minutes and with a whole number of complete belt revolutions. For belt conveyor scales with mechanical integrators, the test shall be performed with no~~

~~less than three complete revolutions or 10 minutes of operation, whichever is greater. A zero-load test shall be performed as follows:~~

- (a) For belt-conveyor scales with electronic integrators, the test must be performed over a period of at least three minutes and with a whole number of complete belt revolutions;
- (b) For belt-conveyor scales with mechanical integrators, the test shall be performed with no less than three complete revolutions or 10 minutes of operation, whichever is greater;
- (c) For weigh belt systems the test must be performed over a period of at least one minute and at least one complete revolution of the belt.

(Added 2002) **(Amended 2015)**

**Background/Discussion:**

Since the typical design of weigh-belt systems (see the Committee’s proposal to add definition in Appendix D for “weigh-belt systems”) consists of significantly shorter conveyors compared to those normally found in BCS systems, the time needed for a complete revolution of the belt to occur on a weigh-belt system is much shorter. The USNWG on BCSs agreed that due to the generally shorter time needed for a belt revolution on a weigh-belt system, the dynamics of the weigh-belt system (including the ability to maintain a zero load reference) could be evaluated without the need of an extended (10 min) period of operation as is required for a BCS system. The USNWG concluded that the weigh-belt system’s ability to maintain a stable zero condition could be sufficiently evaluated over a shorter time span and recommended that, as a minimum, one minute of operation would suffice. This provision has been added in bullet point (c) in the “Item Under Consideration.”

This proposed amendment is also considered to improve the structure of the existing language in paragraph UR.3.1.1. by segregating the requirements for BCSs that use electronic integrators from those that use mechanical integrators into bullet points (a) and (b).

NIST Handbook 44, BCS Systems Code language that existed prior to 2001 provided an exemption for BCS systems designed and furnished by the manufacturer from requirements that concerned the details of installation of BCS systems. Generally, weigh-belt systems are designed and built by the manufacturer as a unit and are, therefore, less likely to be susceptible to malfunctions or operational defects directly caused by a variance from the manufacturer’s intended installation specifications. This is in contrast to BCS systems that are typically installed as separate components (e.g., conveyor, weighing system, belt loading system, speed sensor, etc.) within an existing conveyor system where the details of the installation for each component may greatly influence the performance of other components in the system. That language which has since been deleted is shown below:

**UR.2.2.1. For Scales Not Installed by the Manufacturer.** – Unless the scale is installed in a conveyor designed and furnished by the scale manufacturer or built to the scale manufacturer’s specifications, the conveyor shall comply with the following minimum requirements:

...\*

(Amended 1998)

\*The subparagraphs that followed, UR.2.2.1.(a) through (j), consisted of requirements addressing specific criteria related to design and installation of the conveyor system.

The deletion of the statement: “installed in a conveyor designed and furnished by the scale manufacturer or built to the scale manufacturer’s specifications” created a situation where all BCS systems that were covered by the NIST Handbook 44, BCS Code were to meet requirements that included: specific limitations on the location of conveyor components in relation to the weighing element; specific limits on the length of the conveyor; and the type of take-up device used in the system. Due to their typical design and construction, weigh-belt systems were not generally able to comply with these requirements; this was largely due to the size, placement, and location of components in a weigh-belt type of system and the distances required between those components and the weighing elements.

USNWG members have agreed it is important not to impose prescriptive requirements, which may restrict innovation in the design of this type of device. Requirements that place limitations on the placement of components in a conveyor

system in relation to the weighing device and to each other are viewed as being arbitrary and may be invalid if the design of a system is shown to operate within performance requirements regardless of the configuration of its components.

BCS manufacturers who are members of the USN WG reported a demand from various clients for relatively compact weigh-belt type of systems to be used as a commercial device. However, unless the NIST Handbook 44, BCS Code is amended to allow for their unique design characteristics, there was not an appropriate code in NIST Handbook 44 to apply to weigh-belt systems. Therefore, the USN WG has developed a number of proposed changes throughout the existing BCS Systems Code to adapt these requirements so they may be applied to weigh-belt systems as well.

#### **2015 NCWM Interim Meeting:**

NCWM 2015 Interim Meeting: Agenda Items 321-1 through 321-8 were grouped together and comments taken simultaneously since the Committee considered them all related. Ms. Tina Butcher (OWM) spoke in support of this item. She stated that NIST Handbook 44 included certain exceptions for installations of BCS systems installed under close supervision and control of the scale system manufacturer (prior to 2001). Ms. Butcher went on to state that OWM believes it would be appropriate to reinstate these exemptions for the weigh-belt systems, as proposed by this item. She concurred these items should be grouped together (with perhaps the exception of Item 321-6) and designated as Voting; however, she noted that Item 321-6 is different in that the item does not relate to the addition of the term “weigh-belt systems” into the BCS Systems Code of NIST Handbook 44. Mr. Steve Langford representing the Scale Manufacturer’s Association stated the SMA had no position on these items.

In consideration of the comments provided the Committee agreed to recommend this item for Vote.

NCWM 2015 Annual Meeting Open Hearings: The Committee announced it was grouping Agenda Items 321-1 through 321-8 together and taking comments on all simultaneously. See Agenda Item 321-1 for a summary of the comments heard on these items.

Hearing no comments in opposition and in consideration that these items were developed and recommended by the USN WG on BCSs, the Committee agreed to present Items 321-1 through 321-8 for Vote, each without change as shown in the “Item Under Consideration.”

#### **Regional Association Meetings:**

CWMA 2014 Interim Meeting: The CWMA did not receive comments on this item. The CWMA appreciates the efforts of the WG and believes this item is sufficiently developed. The CWMA forwarded the item to the NCWM recommending it as a Voting item. At the 2015 CWMA Annual Meeting, the CWMA recommended the item be forwarded to the NCWM as a Voting item since there were no opposing comments and the item was supported by the SMA.

WWMA 2014 Annual Meeting: Testimony was presented in support of this item and moving it to a Voting status. The WWMA S&T Committee agreed it was sufficiently developed and recommended that 2014 WWMA S&T Agenda Items 321-1, 321-2, 321-3, 321-4, 321-5, 321-6, 321-7, and 321-8 be combined into one proposal. The WWMA forwarded this item to the NCWM and recommended that it be a Voting item.

SWMA 2014 Annual Meeting: The SWMA recommended Items 321-1 through 321-8 be combined into one agenda item since they are all related to BCSs. Comments were heard on all eight of these agenda items at the same time. The SMWA forwarded this item to the NCWM and recommended it be a Voting item.

NEWMA 2014 Interim Meeting: NEWMA supported the recommendations of the USN WG on BCSs, since the majority of these devices are located outside of the region. NEWMA forwarded the item to the NCWM and recommended that it be a Voting item. During the 2015 NEWMA Annual Meeting, NEWMA’s S&T Committee agreed to group together Agenda Items 321-1 through 321-8 and take comments simultaneously. The SMA supported all items in the group. NEWMA agreed to recommend all items in the group move forward as Voting items.

Additional letters, presentations, and data may have been part of the Committee's consideration. To review the supporting documentation, please refer to the *Report of the 99<sup>th</sup> National Conference on Weights and Measures* (SP1193, 2014).

### 321-6 VC UR.1.2. Conveyor Installation.

(This item was adopted.)

**Source:**

U.S. National Work Group on Belt-Conveyor Scales (BCSs) (2015)

**Purpose:**

Remove ambiguous and prescriptive language that fails to recognize improvements in manufacturing.

**Item Under Consideration:**

Amend NIST Handbook 44, BCS Systems Code as follows:

**UR.1.2. Conveyor Installation**

.....

- (k) **Belt Composition and Maintenance.** – ~~Conveyor belting shall be no heavier than is required for normal use.~~ In a loaded or unloaded condition, the belt shall make constant contact with horizontal and wing rollers of the idlers in the scale area. Splices shall not cause any undue disturbance in scale operation. (Also see N.3. Test Procedures.)

(Amended 1998, 2000, ~~and 2001~~, and 2015)

**Background/Discussion:**

The existing language in the requirement being proposed for deletion is intended to prevent the use of excessively thick, heavy-duty belt material that could be problematic when its rigidity would prevent the belt from making proper contact with the contour of the rollers that support the belt in the weighing area of the system. This could result in poor performance of the weighing system. In addition, a heavier belt would create a larger value for the “dead load” weight that must be accounted for by the scale in an unloaded zero-balance condition.

The USNWG on BCSs considers the use of the term “heavier” to be ambiguous in that it can be interpreted to mean a higher weight value per unit of length or it may mean that the relative thickness of the belt is greater than a “lighter” version of belt material. The USNWG recognizes manufacturers of belt material have made improvements to their products through modernized manufacturing processes and the use of alternative raw materials. These practices have resulted in improvements over the traditional-style belt material and may allow for belts of various thickness or weights to be used without detracting from scale performance.

The language that is proposed to be stricken is viewed as being prescriptive and the USNWG believes that the requirement should not attempt to establish a parameter for the design of belt material. The remaining portion of the requirement is considered as being sufficient for conveying the intent of the requirement in that, regardless of the manufacturing characteristics, the belt must make contact with the supporting rollers and be spliced appropriately to avoid the introduction of significant weighing errors.

NIST Handbook 44, Systems BCS Code language, which existed prior to 2001, provided an exemption for BCS systems designed and furnished by the manufacturer from requirements that concerned the details of installation of BCS systems. Generally, weigh-belt systems are designed and built by the manufacturer as a unit and are, therefore, less likely to be susceptible to malfunctions or operational defects directly caused by a variance from the manufacturer's intended installation specifications. This is in contrast to BCS systems that are typically installed as separate components (conveyor, weighing system, belt loading system, speed sensor, etc.) within an existing conveyor system where the details of the installation for each component may greatly influence the performance of other components in the system. That language, which has since been deleted, is shown below:

**UR.2.2.1. For Scales Not Installed by the Manufacturer.** – Unless the scale is installed in a conveyor designed and furnished by the scale manufacturer or built to the scale manufacturer’s specifications, the conveyor shall comply with the following minimum requirements:

...\*

(Amended 1998)

\*The subparagraphs that followed, UR.2.2.1.(a) through (j), consisted of requirements addressing specific criteria related to design and installation of the conveyor system.

The deletion of the statement, “installed in a conveyor designed and furnished by the scale manufacturer or built to the scale manufacturer’s specifications” created a situation where all BCS systems, which were covered by the NIST Handbook 44, BCS Code, were to meet requirements that included specific limitations on the location of conveyor components in relation to the weighing element; specific limits on the length of the conveyor; and the type of take-up device used in the system. Due to their typical design and construction, weigh-belt systems were not generally able to comply with these requirements; this was largely due to the size, placement, and location of components in a weigh-belt type of system and the distances required between those components and the weighing elements.

USNWG members have agreed that it is important not to impose prescriptive requirements, which may restrict innovation in the design of this type of device. Requirements that place limitations on the placement of components in a conveyor system in relation to the weighing device and to each other are viewed as being arbitrary and may be invalid if the design of a system is shown to operate within performance requirements regardless of the configuration of its components.

BCS manufacturers who are members of the USNWG reported a demand from various clients for relatively compact weigh-belt type of systems to be used as a commercial device. However, unless the NIST Handbook 44, BCS Code is amended to allow for their unique design characteristics, there was not an appropriate code in NIST Handbook 44 to apply to weigh-belt systems. Therefore, the USNWG has developed a number of proposed changes throughout the existing BCS Systems Code to adapt these requirements so that they may be applied to weigh-belt systems as well.

#### **2015 NCWM Interim Meeting:**

NCWM 2015 Interim Meeting: Agenda Items 321-1 through 321-8 were grouped together and comments taken simultaneously since the Committee considered them all related. Ms. Tina Butcher (OWM) spoke in support of this item. She stated that NIST Handbook 44 included certain exceptions for installations of BCS systems installed under close supervision and control of the scale system manufacturer (prior to 2001). Ms. Butcher stated OWM believes it would be appropriate to reinstate these exemptions for the weigh-belt systems, as proposed by this item. She concurred these items should be grouped together (with perhaps the exception of Item 321-6) and designated as Voting; however, she noted that Item 321-6 is different in that the item does not relate to the addition of the term “weigh-belt systems” into the BCS Systems Code of NIST Handbook 44. Mr. Steve Langford, representing the Scale Manufacturer's Association, stated the SMA had no position on these items.

Hearing no comments in opposition to this item, the Committee agreed to recommend this item for vote.

#### **2015 NCWM Annual Meeting:**

NCWM 2015 Annual Meeting Open Hearings: The Committee announced it was grouping Agenda Items 321-1 through 321-8 together and taking comments on all simultaneously. See Agenda Item 321-1 for a summary of the comments heard on these items.

Hearing no comments in opposition and in consideration that these items were developed and recommended by the USNWG on BCSs, the Committee agreed to present Items 321-1 through 321-8 for Vote each without change as shown in the “Item Under Consideration.”

#### **Regional Association Meetings:**

CWMA 2014 Interim Meeting: The CWMA did not receive comments on this item. The CWMA appreciates the efforts of the WG and believes this item is sufficiently developed. The CWMA forwarded the item to the NCWM, recommending it as a Voting item. At the 2015 CWMA Annual Meeting, the CWMA recommended the item be

forwarded to the NCWM as a Voting item since there were no opposing comments, and the item was supported by the SMA.

WWMA 2014 Annual Meeting: Testimony was presented in support of this item and moving it to a Voting Status. The WWMA S&T Committee agreed that it was sufficiently developed and recommended that 2014 WWMA S&T Agenda Items 321-1, 321-2, 321-3, 321-4, 321-5, 321-6, 321-7, and 321-8 be combined into one proposal. The WWMA forwarded this item to NCWM and recommended that it be a Voting item.

SWMA 2014 Annual Meeting: The SWMA recommended: Items 321-1 through 321-8 be combined into one agenda item since they are all related to BCSs. Comments were heard on all eight of these agenda items at the same time. The SMWA forwarded this tem to the NCWM and recommended that it be a Voting item.

NEWMA Interim 2014 Meeting: NEWMA supported the recommendations of the USNWG on BCSs since the majority of these devices are located outside of the northeast region. NEWMA forwarded the item to the NCWM and recommended that it be a Voting item. During the 2015 NEWMA Annual Meeting, NEWMA's S&T Committee agreed to group together Agenda Items 321-1 through 321-8 and take comments simultaneously. The SMA supported all items in the group. NEWMA agreed to recommend all items in the group move forward as Voting items.

Additional letters, presentations, and data may have been part of the Committee's consideration. To review the supporting documentation, please refer to the *Report of the 99<sup>th</sup> National Conference on Weights and Measures* (SP1193, 2014).

**321-7 VC UR.3.1. Scale and Conveyor Maintenance. – ~~Belt-conveyor scales~~ Weighing Systems.**

(This item was Adopted.)

**Source:**

U.S. National Work Group on Belt-Conveyor Scales (BCSs) (2015)

**Purpose:**

Allow paragraph UR.3.1. to apply to weigh-belt systems and require alignment checks whenever work is performed on weigh-belt systems as well as BCS systems that may alter the alignment.

**Item Under Consideration:**

Amend NIST Handbook 44 Belt-Conveyor Scale Systems Code as follows:

**UR.3.1. Scale and Conveyor Maintenance. – ~~Belt-conveyor scales~~ Weighing systems** and idlers shall be maintained and serviced in accordance with manufacturer's instructions and the following:

...  
.  
.

- (e) **Scale Alignment.** – Alignment checks shall be conducted in accordance with the manufacturer's recommendation ~~when conveyor work is performed in the scale area~~. A material test is required after any realignment.

(Amended 1986, ~~and~~ 2000, and 2015)

**Background/Discussion:**

The USNWG on BCSs has proposed a number of changes to the NIST Handbook 44, BCS Code intended to allow the code to be applied to "weigh-belt systems" as well as BCS systems. To facilitate this effort references to "BCSs" are being proposed to be changed to a more inclusive terminology such as is recommended in the first sentence in UR.3.1. (See also remarks in "Additional Considerations" below.) This proposed change is intended to eliminate the exclusion of weigh-belt systems from this requirement.

Since the typical design of weigh-belt systems consists of an all-inclusive unit and significantly shorter conveyors as compared to those normally found in BCS system, *any* work performed on weigh-belt systems could possibly be considered to take place “in the scale area.” (See the Committee’s proposal to add a new definition for “weigh-belt systems” in NIST Handbook 44, Appendix D.) Any misalignment of the conveyor belt during its operation can have a detrimental effect on the performance of the system.

The USNWG on BCS agreed it is appropriate to require alignment checks whenever work is performed on weigh-belt systems (as well as BCS systems) that may alter this alignment. The USNWG members, who are employees of device manufacturers, have stated that the manufacturers of weigh-belt systems will emphasize the critical nature of belt alignment and will specify that owners/operators check the belt alignment if work is performed on the conveyor system that could have any effect on this. Therefore, the USNWG agreed that the proposed change to require an alignment check to be done according to manufacturer’s instructions is a sound proposal.

NIST Handbook 44, BCS Systems Code language, which existed prior to 2001, provided an exemption for BCS systems designed and furnished by the manufacturer from requirements that concerned the details of installation of BCS systems. Generally, weigh-belt systems are designed and built by the manufacturer as a unit and are, therefore, less likely to be susceptible to malfunctions or operational defects directly caused by a variance from the manufacturer’s intended installation specifications. This is in contrast to BCS systems that are typically installed as separate components (e.g., conveyor, weighing system, belt loading system, speed sensor, etc.) within an existing conveyor system where the details of the installation for each component may greatly influence the performance of other components in the system. That language which has since been deleted is shown below:

**UR.2.2.1. For Scales Not Installed by the Manufacturer.** – Unless the scale is installed in a conveyor designed and furnished by the scale manufacturer or built to the scale manufacturer’s specifications, the conveyor shall comply with the following minimum requirements:

...\*

(Amended 1998)

\*The subparagraphs that followed, UR.2.2.1.(a) through (j), consisted of requirements addressing specific criteria related to design and installation of the conveyor system.

The deletion of the statement, “installed in a conveyor designed and furnished by the scale manufacturer or built to the scale manufacturer’s specifications” created a situation where all BCS systems, which were covered by the NIST Handbook 44, BCS Code, were to meet requirements that included specific limitations on the location of conveyor components in relation to the weighing element; specific limits on the length of the conveyor; and the type of take-up device used in the system. Due to their typical design and construction, weigh-belt systems were not generally able to comply with these requirements; this was largely due to the size, placement, and location of components in a weigh-belt type of system and the distances required between those components and the weighing elements.

USNWG members have agreed that it is important not to impose prescriptive requirements, which may restrict innovation in the design of this type of device. Requirements that place limitations on the placement of components in a conveyor system in relation to the weighing device and to each other are viewed as being arbitrary and may be invalid if the design of a system is shown to operate within performance requirements regardless of the configuration of its components.

BCS manufacturers who are members of the USNWG reported a demand from various clients for relatively compact weigh-belt type of systems to be used as a commercial device. However, unless the NIST Handbook 44, BCS Code is amended to allow for their unique design characteristics, there was not an appropriate code in NIST Handbook 44 to apply to weigh-belt systems. Therefore, the USNWG has developed a number of proposed changes throughout the existing BCS Systems Code to adapt these requirements so that they may be applied to weigh-belt systems as well.

#### **2015 NCWM Interim Meeting:**

NCWM 2015 Interim Meeting: Agenda Items 321-1 through 321-8 were grouped together and comments taken simultaneously since the Committee considered them all related. Ms. Tina Butcher (OWM) spoke in support of this item. She stated that NIST Handbook 44 included certain exceptions for installations of BCS systems installed under



close supervision and control of the scale system manufacturer (prior to 2001). Ms. Butcher went on to state that OWM believes it would be appropriate to reinstate these exemptions for the weigh-belt systems, as proposed by this item. She concurred these items should be grouped together (with perhaps the exception of Item 321-6) and designated as Voting; however, she noted that Item 321-6 is different in that the item does not relate to the addition of the term “weigh-belt systems” into the BCS Systems Code of NIST Handbook 44. Mr. Steve Langford representing the Scale Manufacturer's Association stated the SMA had no position on these items.

In consideration of the comments provided the Committee agreed to recommend this item for Vote.

**2015 NCWM Annual Meeting:**

Annual Meeting 2015 Open Hearings: The Committee announced it was grouping Agenda Items 321-1 through 321-8 together and taking comments on all simultaneously. See Agenda Item 321-1 for a summary of the comments heard on these items.

Hearing no comments in opposition and in consideration that these items were developed and recommended by the USNWG on BCSs, the Committee agreed to present Items 321-1 through 321-8 for Vote each without change as shown in Item Under Consideration.

**Regional Association Meetings:**

CWMA 2014 Interim Meeting: The CWMA received a comment from a regulatory official supporting this item. The CWMA appreciates the efforts of the WG and believes this item is sufficiently developed. The CWMA forwarded the item to the NCWM, recommending it as a Voting item. At the 2015 CWMA Annual Meeting, the CWMA recommended the item be forwarded to the NCWM as a Voting item since there were no opposing comments and the item was supported by the SMA.

WWMA 2014 Annual Meeting: Testimony was presented in support of this item and moving it to a Voting status. The WWMA S&T Committee agreed it was sufficiently developed and recommended that 2014 WWMA S&T Agenda Items 321-1, 321-2, 321-3, 321-4, 321-5, 321-6, 321-7, and 321-8 be combined into one proposal. The WWMA forwarded this item to the NCWM and recommended that it be a Voting item.

The SWMA 2014 Annual Meeting: Recommended Items 321-1 through 321-8 be combined into one agenda item since they are all related to BCSs. Comments were heard on all eight of these agenda items at the same time. The SMWA forwarded this item to the NCWM and recommended that it be a Voting item.

NEWMA 2014 Interim Meeting: NEWMA supported the recommendations of the USNWG on BCSs since the majority of these devices are located outside of the northeast region. NEWMA forwarded the item to the NCWM and recommended that it be a Voting item. During the 2015 NEWMA Annual Meeting, NEWMA's S&T Committee agreed to group together Agenda Items 321-1 through 321-8 and take comments simultaneously. The SMA supported all items in the group. NEWMA agreed to recommend all items in the group move forward as Voting items.

Additional letters, presentations, and data may have been part of the Committee's consideration. To review the supporting documentation, please refer to the *Report of the 99<sup>th</sup> National Conference on Weights and Measures* (SP1193, 2014).

**321-8 VC Appendix D – Definitions. – Weigh-Belt Systems.**

(This item was Adopted.)

**Source:** U.S. National Work Group on Belt-Conveyor Scales (BCSs) (2015)

**Purpose:**

Provide a definition for this device type if other proposals are adopted, which would reference it in the BCS Code.

**Item Under Consideration:**

Amend NIST Handbook 44, Appendix D – Definitions as follows:

**weigh-belt systems. – A type of belt-conveyor scale system designed by the manufacturer as a self-contained conveyor system and which is installed as a unit. The units are comprised of integral components including as a minimum: conveyor belt; belt drive; conveyor frame; and weighing system. They may operate at single or multiple flow rates and may use variable-speed belt drives.**

**(Added 2015)**

**Background/Discussion:**

Several terms have been used to describe relatively shorter conveyor systems including “weigh-belts” and “weigh-feeders.” The USN WG agreed that the term “weigh-belt system” is best suited for describing this type of device. The WG also agreed that if this term is to be understood and routinely used to describe a specific type of weighing device/system, then a definition should be developed and included in NIST Handbook 44, Appendix D. Definitions.

Based on the submission of proposed changes to the NIST Handbook 44, Belt-Conveyor Scale (BCS) Systems Code that are intended to facilitate the application of that code to a specific, self-contained type of design devices commonly referred to as “weigh-belt systems,” the USN WG on BCSs agreed it is necessary to establish a definition for this type of device. This definition would help to distinguish the weigh-belt type of systems from the more familiar BCS systems.

NIST Handbook 44, BCS Systems Code language that existed prior to 2001 provided an exemption for BCS systems designed and furnished by the manufacturer from requirements that concerned the details of installation of BCS systems. Generally, weigh-belt systems are designed and built by the manufacturer as a unit and are, therefore, less likely to be susceptible to malfunctions or operational defects directly caused by a variance from the manufacturer’s intended installation specifications. This is in contrast to BCS systems that are typically installed as separate components (conveyor, weighing system, belt loading system, speed sensor, etc.) within an existing conveyor system where the details of the installation for each component may greatly influence the performance of other components in the system. That language, which has since been deleted, is shown below:

**UR.2.2.1. For Scales Not Installed by the Manufacturer.** – Unless the scale is installed in a conveyor designed and furnished by the scale manufacturer or built to the scale manufacturer’s specifications, the conveyor shall comply with the following minimum requirements:

...\*

(Amended 1998)

\*The subparagraphs that followed, UR.2.2.1.(a) through (j), consisted of requirements addressing specific criteria related to design and installation of the conveyor system.

The deletion of the statement, “installed in a conveyor designed and furnished by the scale manufacturer or built to the scale manufacturer’s specifications,” created a situation where all BCS systems that were covered by the NIST Handbook 44, BCS Code were to meet requirements that included specific limitations on the location of conveyor components in relation to the weighing element; specific limits on the length of the conveyor; and the type of take-up device used in the system. Due to their typical design and construction, weigh-belt systems were not generally able to comply with these requirements; this was largely due to the size, placement, and location of components in a weigh-belt type of system and the distances required between those components and the weighing elements.

USN WG members have agreed that it is important not to impose prescriptive requirements, which may restrict innovation in the design of this type of device. Requirements that place limitations on the placement of components in a conveyor system in relation to the weighing device and to each other are viewed as being arbitrary and may be invalid if the design of a system is shown to operate within performance requirements regardless of the configuration of its components.

BCS manufacturers who are members of the USN WG reported a demand from various clients for relatively compact weigh-belt type of systems to be used as a commercial device. However, unless the NIST Handbook 44, BCS Code is amended to allow for their unique design characteristics, there was not an appropriate code in NIST Handbook 44 to apply to weigh-belt systems. Therefore, the USN WG has developed a number of proposed changes throughout the existing BCS Systems Code to adapt these requirements so that they may be applied to weigh-belt systems as well.

**2015 NCWM Interim Meeting:**

NCWM 2015 Interim Meeting: Agenda Items 321-1 through 321-8 were grouped together and comments taken simultaneously since the Committee considered them all related. Ms. Tina Butcher (OWM) spoke in support of this item. She stated that NIST Handbook 44 included certain exceptions for installations of BCS systems installed under close supervision and control of the scale system manufacturer (prior to 2001). Ms. Butcher went on to state that OWM believes it would be appropriate to reinstate these exemptions for the weigh-belt systems, as proposed by this item. She concurred these items should be grouped together (with perhaps the exception of Item 321-6) and designated as Voting; however, she noted that Item 321-6 is different in that the item does not relate to the addition of the term “weigh-belt systems” into the BCS Systems Code of NIST Handbook 44. Mr. Steve Langford representing the Scale Manufacturer's Association stated the SMA had no position on these items.

In consideration of the comments provided the Committee agreed to recommend this item for Vote.

**2015 NCWM Annual Meeting:**

NCWM 2015 Annual Meeting Open Hearings: The Committee announced it was grouping Agenda Items 321-1 through 321-8 together and taking comments on all simultaneously. See Agenda Item 321-1 for a summary of the comments heard on these items.

Hearing no comments in opposition and in consideration that these items were developed and being recommended by the USNWG on BCSs, the Committee agreed to present Items 321-1 through 321-8 for Vote, each without change as shown in Item Under Consideration.

**Regional Association Meetings:**

CWMA 2014 Interim Meeting: The CWMA did not receive comments on this item. The CWMA appreciates the efforts of the WG and believes this item is sufficiently developed. The CWMA forwarded the item to the NCWM, recommending it as a Voting item. At the 2015 CWMA Annual Meeting, the CWMA recommended the item be forwarded to the NCWM as a Voting item since there were no opposing comments and the item was supported by the SMA.

WWMA 2014 Annual Meeting: Testimony was presented in support of this item and moving it to a Voting status. The WWMA S&T Committee agreed that it was sufficiently developed and recommended that 2014 WWMA S&T Agenda Items 321-1, 321-2, 321-3, 321-4, 321-5, 321-6, 321-7, and 321-8 be combined into one proposal. The WWMA forwarded this item to the NCWM and recommended that it be a Voting item.

The SWMA 2014 Annual Meeting: The SWMA recommended, at its, Items 321-1 through 321-8 be combined into one agenda item since they are all related to BCSs. Comments were heard on all eight of these agenda items at the same time. The SWMA forwarded this tem to the NCWM and recommended that it be a Voting item.

NEWMA2014 Interim Meeting: NEWMA supported the recommendations of the USNWG on BCSs since the majority of these devices are located outside of the northeast region. NEWMA forwarded the item to the NCWM and recommended that it be a Voting item. During the 2015 NEWMA Annual Meeting, NEWMA’s S&T Committee agreed to group together Agenda Items 321-1 through 321-8 and take comments simultaneously. The SMA supported all items in the group. NEWMA agreed to recommend all items in the group move forward as Voting items.

Additional letters, presentations, and data may have been part of the Committee’s consideration. To review the supporting documentation, please refer to the *Report of the 99<sup>th</sup> National Conference on Weights and Measures* (SP1193, 2014).

## 322 AUTOMATIC BULK WEIGHING SYSTEMS

### 322-1 D N.1. Testing Procedures.

**Source:**

Oregon (2015)

**Purpose:**

Modify the test method to reflect as-used dynamic conditions.

**Item Under Consideration:**

Amend NIST Handbook 44, Automatic Bulk Weighing Systems Code as follows:

#### N.1. Testing Procedures.

~~N.1.1. Test Weights.—The increasing load test shall be conducted using test weights equal to at least 10 % of the capacity of the system:~~

~~(a) on automatic grain bulk weighing systems installed after January 1, 1984; and~~

~~(b) on other automatic bulk weighing systems installed after January 1, 1986.~~

~~(Amended 1987)~~

~~N.1.2. Increasing Load Test.—An increasing load test consisting of substitution and strain load tests shall be conducted up to the used capacity of the weighing system.~~

~~(Amended 1987)~~

~~N.1.3. Decreasing Load Test.—A decreasing load test shall be conducted on devices used to weigh out.~~

~~(Added 1986)~~

N.1.1. Material Tests. – Material used for test must be the actual material weighed by system or similar in nature. Material tests should be conducted using actual scale loading conditions. These loading conditions shall include, three accumulation tests consisting of three loadings at maximum capacity for the material and a partial loading of between 30 % and 50 % (three and a partial loadings).

On subsequent verifications, at least two individual accumulation tests shall be conducted. The results of all tests shall be within tolerance limits.

Either pass a quantity of pre-weighed material through the Automatic Bulk Weighing system in a manner as similar as feasible to actual loading conditions, or weigh all material that has passed through the Automatic Bulk Weighing System. Means for weighing the material test load will depend on the capacity of the system and availability of a suitable scale for the test. To assure that the test load is accurately weighed and determined, the following precautions shall be observed:

(a) The containers, whether railroad cars, trucks, or boxes, must not leak, and shall not be overloaded to the point that material will be lost.

(b) The actual empty or tare weight of the containers shall be determined at the time of the test. Stenciled tare weight of railway cars, trucks or boxes shall not be used. Gross and tare weights shall be determined on the same scale.

**(c) When a pre-weighed test load is passed through the scale, the loading system shall be examined before and after the test to assure that the system is empty and that only the material of the test load has passed through the scale.**

**(d) Where practicable, a reference scale should be tested within 24 hours preceding the determination of the weight of the test load used for an Automatic Bulk Weighing System material test.**

**A reference scale which is not “as found” within maintenance tolerance should have its accuracy re-verified after the Automatic Bulk Weighing System test with a suitable known weight load if the “as found” error of the Automatic Bulk Weighing System material test exceeds maintenance tolerance values.\***

**(e) If any suitable known weight load other than a certified test weight load is used for re-verification of the reference scale accuracy, its weight shall be determined on the reference scale after the reference scale certification and before commencing the Automatic Bulk Weighing System material test.\***

**(f) The test shall not be conducted if the weight of the test load has been affected by environmental conditions.**

**\*Note: Even if the reference scale is within maintenance tolerance it may require adjusting to be able to meet paragraph N.1.1.1. Accuracy of Material.**

**N.1.1.1. Accuracy of Material. – The quantity of material used to conduct a material test shall be weighed on a reference scale to an accuracy within 0.1 %. Scales typically used for this purpose include Class III and III L scales or a scale without a class designation as described in Handbook 44, Section 2.20., Table T.1.1. Tolerances for Unmarked Scales.**

**N.1.1.2. Associated Equipment. – All associated equipment in local vicinity shall be in operation at time of test. This would include items such as conveyors; tote dumps, cleaning drums, rock separators, etc.**

**N.1.4. N.1.2. Zero-Balance or No-Load Reference Value Change Test.** – A test for change of zero-balance or no-load reference value shall be conducted on all scales after the removal of any test load. The change shall not be more than the minimum tolerance applicable.

**N.1.5. N.1.3. Discrimination Test.** – *A discrimination test shall be conducted on all automatic indicating scales with the weighing device in equilibrium at zero-load and at maximum test load, and under controlled conditions in which environmental factors are reduced to the extent that they will not affect the results obtained.*

*[Nonretroactive as of January 1, 1986]*

**N.1.5.1. N.1.3.1. Digital Device.** – On a digital device, this test is conducted from just below the lower edge of the zone of uncertainty for increasing-load tests, or from just above the upper edge of the zone of uncertainty for decreasing-load tests.

(Added 1987)

**~~T.1.2. To Increasing Load Tests. Basic tolerances shall be applied.~~**

**~~T.1.3. To Decreasing Load Tests. Basic tolerances shall be applied to systems used to weigh out.~~**

(Added 1986)

~~T.1.4.~~ **T.1.2. To Tests Involving Digital Indications or Representations.** – To the tolerances that would otherwise be applied, there shall be added an amount equal to one-half the value of the scale division. This does not apply to digital indications or recorded representations that have been corrected for rounding using error weights.

(Added 1986)

### **T.3. Basic Tolerance Values.**

**T.3.1. Acceptance Tolerance.** – The basic acceptance tolerance shall be one-half the basic maintenance tolerance.

**T.3.2. For Systems Used to Weigh Grain.** – The basic maintenance tolerance shall be 0.1 % of ~~test load~~ **accumulation material test.**

**T.3.3. For All Other Systems.** – The basic maintenance tolerance shall be 0.2 % of ~~test load~~ **accumulation material test.**

(Amended 1986)

**T.5. Repeatability.** – The ~~results obtained by several weighings of the same load under reasonably static test conditions~~ **variation in the values obtained during the conduct of accumulation material** tests shall agree within the absolute value of the maintenance tolerance for that load, and shall be within applicable tolerances.

(Added 1986) (**Amended 20XX**)

#### **Background/Discussion:**

The purpose of this proposal is to change the test notes and tolerances to reflect the way these devices are actually used. These are not “static” devices they are “dynamic.” Being dynamic devices, they have many additional factors affecting their accuracy compared to static devices. Some of these additional factors are: timing of gates and conveyors; additional vibration from system while trying to capture weight; operation of software; characteristics of materials being weighed; and environmental situations.

While evaluating Automatic Bulk Weighing Systems in the State of Oregon it was found that devices meeting static testing tolerances were in fact weighing with errors as high as 6 %. Through investigation it was found that a high percentage of the Automatic Bulk Weighing Systems in the state were in fact weighing in error when operating in their normal dynamic mode. These same devices would have received approval using only static methods.

The fundamentals of testing call for “testing as used.” This proposal lays out a method to do exactly that “test as used.”

Some facilities may find it difficult to accommodate the material test method. There may be substantial cost in restructuring facilities to allow for either the capture or introduction of test material.

Adopting this proposal would align the requirements with those of another dynamic device type, BCSs, which are addressed in NIST Handbook 44, Section 2.21.

#### **2015 NCWM Interim Meeting:**

NCWM 2015 Interim Meeting: The SMA opposed this item, providing the rationale that this item should be addressed in the initial verification of the device and not affect the type evaluation testing procedures.

Mr. Doug Deiman (AK) stated that while the proposal provided by the State of Oregon is a serious issue that needs to be addressed, he could not support a material test as written and gave an example of a test of fish scales commonly used in Alaska. As an illustration, Mr. Deiman noted that it would be necessary to procure thousands of pounds of fish to conduct each test and that the product would be largely destroyed in the process. He also noted that a test using substitute material would also be cumbersome and present a different set of problems. Mr. Deiman also pointed out

that the material testing would largely be a waste of time, based on the data provided by the submitter, which showed that gate timing was the problem on many of the test results. Mr. Deiman noted that gate timing is a process that is controlled and adjusted outside the sealable parameters of the system and could easily be manipulated after the tests are performed. Mr. Deiman stated he could not give a recommendation to the Committee on a course of action, but he could not support the proposal as written.

Mr. Jeff McLaughlin (InterSystems, Inc.) provided comments in opposition to the proposal, questioning how the same NIST Handbook 44 tolerances can be applied to both static and material tests.

Mr. Richard Suiter (Richard Suiter Consulting) stated he sees a lot of problems with the way the proposal was written. He voiced opposition to removing the static test from the ABWS Code and identified a number of concerns relating to the selection of a suitable reference scale including:

- the value of its minimum scale division (d);
- its degree of accuracy; and
- its location and distance from the ABWS that is to be tested.

Ms. Tina Butcher (OWM) provided a summary of OWM's analysis of this item, which has been copied below and was made available to the NCWM membership during the Open Hearings of the S&T Committee.

*OWM Analysis S&T Item 324-1*

A material test may have merit. The data provided by the State of Oregon during the 2014 Western Weights and Measures Association's Annual Meeting and included in their Annual Report seems to suggest that the results of a static test are not a true reflection of the accuracy of an ABWS when it is being operated in its normal automatic mode. For this reason, OWM encourages careful consideration be given when deciding the need for whether or not a material test should be part of the official examination of an ABWS. Although there are questions concerning the procedures used to collect the data, OWM believes that because of the magnitude of difference in the error when comparing results of static versus material tests, the concern being raised is worthy of additional investigation. OWM notes that a material test is part of Measurement Canada's Field Inspection Manual for ABWSs (referred to as "Bulk Weighing" or "Discontinuous Totalizing Devices") and of type evaluation criteria using OIML R 107 Discontinuous totalizing automatic weighing instruments (totalizing hopper weighers).

With regard to testing both statically (using physical standards) and dynamically (using reference material), OWM believes there may be value to both tests in that the results of each might be used to detect different problems within the system. For example, results of a static test might determine the accuracy of the scale and whether or not adjustment is necessary. If the static test proves the scale accurate, then inaccuracies detected during a material test might provide an indication of problems of another sort; for example, improper venting, vibration, printing of unstable weight indications, etc. In considering the future possibility of NIST Handbook 44 requiring both tests, the following are some unanswered questions raised by members of OWM's Legal Metrology Devices Program:

1. Should there be a different tolerance applied for each test, and if so, what should the tolerance be for each test?
2. What would be the proper use of adjustment required by a service technician when adjusting the scale to "as close to zero error as practical?" For example, would adjustments be made based on the results of the dynamic testing or the static testing?
3. Should the results of a static test be compared to the results of a material test and a repeatability tolerance applied? (OWM does not believe a repeatability tolerance should be applied to the results of different tests.)

The following are some additional issues, concerns, comments, and questions identified by OWM as needing to be addressed, including additional follow-up work needed in consideration of this proposal:

1. How does one account for the loss of material caused by conveyance of the reference material (e.g., water loss, if weighing wet commodities such as fish; grain loss if using circulating augers to transfer; etc.)? Guidelines for weighing and controlling the reference material will need to be developed.
2. Guidelines will also need to be established for determining the suitability and accuracy of the reference scale used to weigh the material used for the material test and the timing of the testing in relation to when material tests are conducted.
3. Can we get more comparison data for other commodities?
4. Should the material test be optional? This item isn't ready for vote – the issue needs more investigation.
5. How many material tests need to be conducted considering the weight/varieties of commodities weighed?

As a final note pertaining to proposed paragraph N.1.1.1. Accuracy of Material, OWM wishes to point out that it would not be appropriate to use material weighed to an accuracy within 0.1 % as a standard in testing another scale that has an applicable tolerance of 0.05 % (the current basic acceptance tolerance applicable to an ABWS used to weigh grain) or 0.1 % (the current basic acceptance tolerance applicable to an ABWS used to weigh products other than grain). The Fundamental Considerations of NIST Handbook 44 require the combined error and uncertainty of any standard used without correction to be less than one-third the applicable tolerance of the device being tested. In the case of a material test, the material that gets weighed on a suitable reference scale becomes the standard in testing when conducting the material tests. Thus, to be able to meet this requirement for use as a standard in testing an ABWS used to weigh grain, the maximum combined error and uncertainty of the material would need to be less than 0.033 % of its actual weight if applying basic acceptance tolerance (i.e., a value smaller than the quotient resulting from dividing 0.1 % by 3) unless corrections are made.

In discussing this item, several members of the Committee voiced disappointment that the submitter of the item was not present at the meeting to provide additional information concerning the data that had been collected or to answer questions regarding the proposal. The Committee initially considered withdrawing the item, but chose to assign it a Developing status in consideration of the large weighing errors reported, which were allegedly caused by weighing product using an ABWS in automatic operation soon after the scale portion of the ABWS had been tested statically and approved. In assigning the Developing status, the Committee wanted to provide the submitter the opportunity to develop the proposal further and receive additional input from the regional weights and measures associations.

#### **2015 NCWM Annual Meeting:**

NCWM 2015 Annual Meeting: Mr. Steve Harrington (Oregon) reported that the State of Oregon's development of the item is ongoing. He asked that the Committee maintain its Developing status of the item to allow sufficient time for the Oregon to complete a more detailed proposal.

Mr. Russ Vires (Mettler-Toledo, LLC), speaking on behalf of the SMA reported that the SMA opposes the item. The SMA believes this item should be addressed in the initial verification of the device and not affect the type evaluation testing procedures.

A county official from the State of California commented that ABWS testing needs to start with a static test. A material test should be optional at the discretion of the official.

Ms. Tina Butcher (OWM) commented that OWM acknowledges it may not be practical to perform a material test on all ABWSs due to the large capacities of some systems and/or the types of commodities weighed. This point should be considered when further developing any proposal to add a material test to the ABWS Code of NIST Handbook 44; this includes clarifying when a test would be required and when a test would be conducted at the discretion of an official.

Ms. Butcher noted that a material test is part of Measurement Canada's Field Inspection Manual for ABWSs and the international type evaluation criteria included in OIML R 107. MC usually conducts both static and material tests on



ABWSs at facilities receiving inbound grain from the field. MC's S&T advisor reported that MC officials do NOT conduct a material test on *all* ABWSs. Two examples where a material test is *not* typically performed:

- 1) some larger capacity ABWSs (e.g., systems at export terminals used to weigh grain for ship loading); and
- 2) ABWSs used to weigh fish being received in bulk from commercial fishing vessels.

Ms. Butcher also reiterated many of the more significant points OWM had made in its analysis of the item for the 2015 Interim Meeting as follows:

- A material test may have merit. Data provided by the State of Oregon at the 2014 WWMA meeting seems to suggest that the results of a static test are not a true reflection of the accuracy of an ABWS in normal operation. Careful consideration should be given when deciding the need for whether or not a material test should be part of the official examination of an ABWS. The magnitude of difference in the error being reported when comparing results of static versus material tests makes it worthy of additional investigation.
- There may be value to testing both statically (using physical standards) and dynamically (using reference material).
- With regard to proposed paragraph N.1.1.1. Accuracy of Material, it would be inappropriate to use material weighed to an accuracy within 0.1 % as a standard in testing another scale that has an applicable tolerance of 0.05 % (the current basic acceptance tolerance applicable to an ABWS used to weigh grain) or 0.1 % (the current basic acceptance tolerance applicable to an ABWS used to weigh products other than grain).

She also reiterated many of issues, concerns, comments, and questions identified as needing to be addressed by members of OWM's Legal Metrology Devices Program (LMDP) in its analysis of this item leading up the NCWM Interim meeting as follows:

- Should there be a different tolerance applied for the different tests (static and material), and if so, what should the tolerance be for each test?
- What would be the proper use of adjustment required by a service technician when adjusting the scale to as close to zero error as practical?
- Should the results of a static test be compared to the results of a material test and a repeatability tolerance applied? (OWM does not believe a repeatability tolerance should be applied to the results of different tests.)
- Guidelines for weighing and controlling the reference material will need to be developed that provides instructions including: how to account for the loss of material caused by conveyance of the reference material (e.g., water loss, if weighing wet commodities such as fish; grain loss, if using circulating augers to transfer; etc.), and will tests need to be performed using all types of materials (products) that are weighed by the system?
- Guidelines will also need to be established for determining the suitability and accuracy of the reference scale used to weigh the material used for the material test and the timing of the reference scale testing in relation to when material tests are conducted.
- Is it possible to collect additional data for the weighing of other commodities (e.g., grain, seed, and coal) in this type of system?

In consideration of the comments received in support of this item and its ongoing development, the Committee agreed to maintain the Developing status of this item on its agenda.

**Regional Association Comments:**

CWMA 2014 Interim Meeting: The CWMA received a comment from an industry representative suggesting retaining the stricken language and potentially using the new language as a supplemental test method. The CWMA reported to the NCWM that it was unable to consider the item at this time, yet noted that it supported the development of this item. At the 2015 CWMA Annual Meeting, the SMA opposed this item providing the rationale that the issue should be addressed in the initial verification of the device and not affect the type evaluation testing procedures. The CWMA agreed to recommend the item move forward as a Developing item based on the CWMA S&T Committee's support for continued development.

Testimony was provided both for and against the proposal at the 2014 WWMA Annual Meeting. Several concerns were raised with the elimination of static testing in the original proposal. The item was updated based on these concerns to include both static and dynamic testing. In addition, the proposal will more closely align NIST Handbook 44 with OIML recommendations. The WWMA forwarded the item to the NCWM and recommended it as a Voting item as amended below:

**N.1.4. Material Tests. – Material used for test must be the actual material weighed by system or similar in nature. Material tests should be conducted using actual scale loading conditions. These loading conditions shall include, three accumulation tests consisting of three loadings at maximum capacity for the material and a partial loading of between 30 % and 50 % (three and a partial loadings).**

**On subsequent verifications, at least two individual tests shall be conducted. The results of all tests shall be within tolerance limits.**

**Either pass a quantity of pre-weighed material through the Automatic Bulk Weighing system in a manner as similar as feasible to actual loading conditions, or weigh all material that has passed through the Automatic Bulk Weighing System. Means for weighing the material test load will depend on the capacity of the system and availability of a suitable scale for the test. To assure that the test load is accurately weighed and determined, the following precautions shall be observed:**

- (a) **The containers, whether railroad cars, trucks, or boxes, must not leak, and shall not be overloaded to the point that material will be lost.**
- (b) **The actual empty or tare weight of the containers shall be determined at the time of the test. Stenciled tare weight of railway cars, trucks or boxes shall not be used. Gross and tare weights shall be determined on the same scale.**
- (c) **When a pre-weighed test load is passed through the scale, the loading system shall be examined before and after the test to assure that the system is empty and that only the material of the test load has passed through the scale.**
- (d) **Where practicable, a reference scale should be tested within 24 hours preceding the determination of the weight of the test load used for an Automatic Bulk Weighing System material test.**

**A reference scale which is not “as found” within maintenance tolerance should have its accuracy re-verified after the Automatic Bulk Weighing System test with a suitable known weight load if the “as found” error of the Automatic Bulk Weighing System material test exceeds maintenance tolerance values.\***

- (e) **If any suitable known weight load other than a certified test weight load is used for re-verification of the reference scale accuracy, its weight shall be determined on the reference scale after the reference scale certification and before commencing the Automatic Bulk Weighing System material test.\***

- (f) **The test shall not be conducted if the weight of the test load has been affected by environmental conditions.**

**\*Note: Even if the reference scale is within maintenance tolerance it may require adjusting to be able to meet paragraph N.1.1.1. Accuracy of Material.**

**N.1.4.1. Accuracy of Material. – The quantity of material used to conduct a material test shall be weighed on a reference scale to an accuracy within 0.1 %. Scales typically used for this purpose include Class III and III L scales or a scale without a class designation as described in Handbook 44, Section 2.20., Table T.1.1. Tolerances for Unmarked Scales.**

**N.1.4.2. Associated Equipment. – All associated equipment in local vicinity shall be in operation at time of test. This would include items such as conveyors; tote dumps, cleaning drums, rock separators, etc.**

**N.1.4. N.1.5. Zero-Balance or No-Load Reference Value Change Test.** – A test for change of zero-balance or no-load reference value shall be conducted on all scales after the removal of any test load. The change shall not be more than the minimum tolerance applicable.

**N.1.5. N.1.6. Discrimination Test.** – *A discrimination test shall be conducted on all automatic indicating scales with the weighing device in equilibrium at zero-load and at maximum test load, and under controlled conditions in which environmental factors are reduced to the extent that they will not affect the results obtained.*

*[Nonretroactive as of January 1, 1986]*

**N.1.5.1. N.1.6.1. Digital Device.** – On a digital device, this test is conducted from just below the lower edge of the zone of uncertainty for increasing-load tests, or from just above the upper edge of the zone of uncertainty for decreasing-load tests.

(Added 1987)

### **T.3. Basic Tolerance Values.**

**T.3.2. For Systems Used to Weigh Grain.** – The basic maintenance tolerance shall be 0.1 % ~~of~~ **and apply to both the test load and material test.**

**T.3.3. For All Other Systems.** – The basic maintenance tolerance shall be 0.2 % ~~of~~ **and apply to both the test load and material test.**

(Amended 1986)

### **T.5. Repeatability.**

**T.5.1. Static Test Load** – The results obtained by several weighings of the same load under reasonably static test conditions shall agree within the absolute value of the maintenance tolerance for that load, and shall be within applicable tolerances.

(Added 1986)

**T.5.2. Material Test – Variation in the values obtained during the conduct of material tests shall agree within the absolute value of the maintenance tolerance for that load, and shall be within applicable tolerances.**

SWMA 2014 Annual Meeting: The SWMA recommended forwarding the language as drafted by the submitter after the Western Regional Meeting to the NCWM S&T so long as it is an optional test and recommended that the item be a Voting item.

NEWMA reported, at its 2014 Interim Meeting, it believes the justification for the proposal has merit. NEWMA recommended the item be forwarded to the NCWM for Vote. At its 2015 Annual Meeting, NEWMA's S&T Committee indicated more work needs to be completed on this item and recommended it remain in a Developing status. Consequently, NEWMA agreed to recommend the item move forward as a Developing item.

Additional letters, presentations, and data may have been part of the Committee's consideration. To review the supporting documentation, please refer to the *Report of the 99<sup>th</sup> National Conference on Weights and Measures* (SP1193, 2014).

## 324 AUTOMATIC WEIGHING SYSTEMS

### 324-1 W A.1. General.

(This item was Withdrawn.)

**Source:**

KSi Conveyors, Inc. (2015)

**Purpose:**

Provide clarity in NIST Handbook 44 as to what standards apply to weighing and measuring systems that provide a finished product based on the measurement of raw materials.

**Item Under Consideration:**

Amend NIST Handbook 44, Automatic Weighing Systems Code as follows:

**A.1. General.** – This code applies to devices used to automatically weigh pre-assembled discrete loads or single loads or loose materials in applications where automatic weighing systems<sup>1</sup> are used or employed in the determination of quantities, things, produce, or articles for distribution, for purchase, offered or submitted for sale, for distribution, purchase, or in computing any basic charge or payment for services rendered on the basis of weight, and in packaging plants subject to regulation by the USDA. Some weigh-labelers and checkweighers may also include a scale that is incorporated in a conveyor system that weighs packages in a static or non-automatic weighing mode.<sup>2</sup>

This includes:

- (a) Automatic weigh-labelers;
- (b) Combination automatic and non-automatic weigh-labelers;
- (c) Automatic checkweighers;
- (d) **Automatic batching systems;**
- (~~e~~) Combination automatic and non-automatic checkweighers; and
- (~~f~~) Automatic gravimetric filling machines that weigh discrete loads or single loads of loose materials and determine package and production lot compliance with net content representations.

(Amended 1997 and 2004)

<sup>1</sup>An automatic weighing system does not require the intervention of an operator during the weighing process. The necessity to give instructions to start a process or to release a load or the function of the instrument (static, dynamic, set-up, etc.) is not relevant in deciding the category of automatic or non-automatic instruments.

(Added 2004)

<sup>2</sup>Prepackaging scales (and other commercial devices) used for putting up packages in advance of sale are acceptable for use in commerce if all appropriate provisions of NIST Handbook 44 are met. Users of such devices must be alert to the legal requirements relating to the declaration of quantity on a package. Such requirements are to the effect that, on the average, the contents of the individual packages of a particular commodity comprising a lot, shipment, or delivery must contain at least the quantity declared on the label. The fact that a scale or other commercial device may overregister, but within established tolerances, and is approved for commercial service is not a legal justification for packages to contain, on the average, less than the labeled quantity.

(Added 2004)

**Background/Discussion:**

The proposed addition to reference “batching systems” in the Application section of the Automatic Weighing Systems Code will accompany the proposal to add a definition for “batching systems” to NIST Handbook 44, Appendix D – Definitions. The CWMA has already agreed to forward the definition to the NCWM S&T Committee with the recommendation that it be a Voting item. The CWMA noted that the definition needs to reference the specific codes where the definition is applicable.

There are both automatic and non-automatic batching systems that utilize scales and/or meters already in the marketplace and there have been such devices in use for many years. The lack of a definition and the accompanying references may have just been an oversight on the part of the NCWM S&T Committee. For further clarification and justification please refer to the proposal in Item 360-1 to add a definition for “batching systems” which was also submitted to the SWMA for consideration.

**2015 NCWM Interim Meeting:**

The Committee agreed to group Agenda Items 320-1, 324-1, 330-1, and 360-1 together since these items are related and announced that comments on all four items would be taken together during its Open Hearings. The Committee agreed to withdraw these items in consideration of the comments and analysis that were provided. Refer to Agenda Item 320-1 for a summary of the comments provided concerning these four items and the reasons why they were withdrawn.

**Regional Association Meetings:**

SWMA 2014 Annual Meeting: The SWMA did not hear any comments in opposition to this item. The SWMA suggested that the NCWM S&T Committee may wish to consider merging Agenda Items 320-1, 324-1, 330-1, and 360-1 since they are all related. Comments were heard for all four of these agenda items at the same time. Mr. Dick Suiter (Richard Suiter Consulting) speaking on behalf of KSi Conveyors, Inc., provided an explanation and need for this item stating current language didn’t address auto-batching (or “all in one”) units. Several members asked questions regarding the proposals and some indicated confusion with the language. The SWMA forwarded the item to the NCWM recommending it as a Voting item.

Additional letters, presentations, and data may have been part of the Committee’s consideration. To review the supporting documentation, please refer to the *Report of the 99<sup>th</sup> National Conference on Weights and Measures* (SP1193, 2014).

**330 LIQUID MEASURING DEVICES**

**330-1 W A.1. General.**

(This item was Withdrawn.)

**Source:**

KSi Conveyors, Inc. (2015)

**Purpose:**

Provide clarity in NIST Handbook 44 as to what standards apply to weighing and measuring systems that provide a finished product based on the measurement of raw materials.

**Item Under Consideration:**

Amend NIST Handbook 44, Liquid-Measuring Devices Code as follows:

**A.1. General.** – This code applies to:

- (a) devices used for the measurement of liquids, including liquid fuels and lubricants; ~~and~~
- (b) ~~wholesale~~ devices used for the measurement and delivery of agri-chemical liquids such as fertilizers, feeds, herbicides, pesticides, insecticides, fungicides, and defoliants; and
- (c) liquid batching systems using meters to measure raw materials.  
(Added 1985)

**Background/Discussion:**

The proposed addition to reference “batching systems” in the Application Section of the LMD Code will accompany the proposal to add a definition for “batching systems” to NIST Handbook 44, Appendix D – Definitions. The CWMA has already agreed to forward the definition to the NCWM S&T Committee with the recommendation that it be a Voting item. The CWMA noted that the definition needs to reference the specific codes where the definition is applicable. With the current definition for “retail” referring to an end user, the term “wholesale” should be removed from A.1.(b).

There are both automatic and non-automatic batching systems that utilize scales and/or meters already in the marketplace, and there have been such devices in use for many years. The lack of a definition and the accompanying references may have just been an oversight on the part of the NCWM S&T Committee. For further clarification and justification, please refer to the proposal in Item 360-1 to add a definition for “batching systems,” which was also submitted to the SWMA for consideration.

**2015 NCWM Interim Meeting:**

The Committee agreed to group Agenda Items 320-1, 324-1, 330-1, and 360-1 together since these items are related and announced that comments on all four items would be taken together during the Open Hearings. The Committee agreed to withdraw these items in consideration of the comments and analysis that were provided. Refer to Agenda Item 320-1 for a summary of the comments provided concerning these four items and the reasons why they were withdrawn.

**Regional Association Meetings:**

**SWMA 2014 Annual Meeting:** The SWMA requested an explanation from the submitter as to why “wholesale” was stricken from the language in the proposal. The submitter explained when the definition for “retail” was amended last, it referenced the end user, which excluded retail applications under the new definition. The SWMA did not hear any comments in opposition to this item. SWMA suggested that the NCWM S&T Committee may wish to consider merging agenda Items 320-1, 324-1, 330-1, and 360-1 since they are all related. Comments were heard for all four of these agenda items at the same time. The SWMA forwarded the item to the NCWM, recommending it as a Voting item.

Additional letters, presentations, and data may have been part of the Committee’s consideration. To review the supporting documentation, please refer to the *Report of the 99<sup>th</sup> National Conference on Weights and Measures* (SP1193, 2014).

**330-2 V Table S.2.2. Categories of Device and Methods of Sealing.**

(This item was Adopted.)

**Source:**

Gilbarco, Inc. (2015)

**Purpose:**

Recognize an electronic means to transfer the event logger information for Category 3 event loggers.

**Item Under Consideration:**

Amend NIST Handbook 44, Liquid Measuring Devices Code as follows:

<i><b>Table S.2.2. Categories of Device and Methods of Sealing</b></i>	
<i><b>Categories of Device</b></i>	<i><b>Methods of Sealing</b></i>
<p><i><b>Category 1:</b> No remote configuration capability.</i></p>	<p><i>Seal by physical seal or two event counters: one for calibration parameters and one for configuration parameters.</i></p>
<p><i><b>Category 2:</b> Remote configuration capability, but access is controlled by physical hardware.</i></p> <p><i>The device shall clearly indicate that it is in the remote configuration mode and record such message if capable of printing in this mode or shall not operate while in this mode.</i></p>	<p><i>[The hardware enabling access for remote communication must be on-site. The hardware must be sealed using a physical seal or an event counter for calibration parameters and an event counter for configuration parameters. The event counters may be located either at the individual measuring device or at the system controller; however, an adequate number of counters must be provided to monitor the calibration and configuration parameters of the individual devices at a location. If the counters are located in the system controller rather than at the individual device, means must be provided to generate a hard copy of the information through an on-site device.]*</i></p> <p><i>[*Nonretroactive as of January 1, 1996]</i></p>
<p><i><b>Category 3:</b> Remote configuration capability access may be unlimited or controlled through a software switch (e.g., password).</i></p> <p><i>[Nonretroactive as of January 1, 1995]</i></p> <p><i>The device shall clearly indicate that it is in the remote configuration mode and record such message if capable of printing in this mode or shall not operate while in this mode.</i></p> <p><i>[Nonretroactive as of January 1, 2001]</i></p>	<p><i>An event logger is required in the device; it must include an event counter (000 to 999), the parameter ID, the date and time of the change, and the new value of the parameter. A printed copy of the information must be available <u>on demand</u> through the device or through another on-site device. <u>The information may also be available electronically.</u> The event logger shall have a capacity to retain records equal to 10 times the number of sealable parameters in the device, but not more than 1000 records are required. (Note: Does not require 1000 changes to be stored for each parameter.)</i></p>

*[Nonretroactive as of January 1, 1995]*

(Table Added 1993) (Amended 1995, 1998, 1999, ~~and 2006~~, and 2015)

**Background/Discussion:**

This proposal would recognize the use of an electronic means such as a thumb drive, flash drive, laptop computer, e-mail, or cell phone to receive event logger information from a dispenser or another on-site device. Event logger information in an electronic format is easier to sort and search than the traditional paper format. Paper versions of the event logger cannot be readily sorted and analyzed like an electronic log. NIST Handbook 44 allows the use of electronic receipts for consumers. Event loggers could be developed to take advantage of technology to facilitate weights and measures officials' review of event logs. A point to consider in evaluating this proposal is that weights and measures officials may not have means to receive the electronic version of the event logger.

**2015 NCWM Interim Meeting:**

NCWM 2015 Interim Meeting: The Committee considered the following proposal to amend the sealing requirements for Category 3 devices covered by the Liquid Measuring Devices Code:

*An event logger is required in the device; it must include an event counter (000 to 999), the parameter ID, the date and time of the change, and the new value of the parameter. **The use of an electronic means such as a thumb drive, flash drive, laptop computer, e-mail, cell phone may be used to receive the event logger information from a dispenser or another on-site device.** A printed copy of the information must be available through the device or through another on-site device **if the device is not equipped to offer an electronic means of supplying the information.** The event logger shall have a capacity to retain records equal to 10 times the number of sealable parameters in the device, but not more than 1000 records are required. (Note: Does not require 1000 changes to be stored for each parameter.)*

During the Open Hearings, Mr. Gordon Johnson (Gilbarco), submitter of the item, gave a short presentation on the merits of the proposal. During the presentation, Mr. Johnson requested that the original language proposed be amended to that shown in "Item Under Consideration." He noted this new language also incorporated slight changes that had been recommended by the Meter Manufacturers Association, and he agreed with those changes.

Ms. Tina Butcher (OWM) commented that while OWM understands the desire to make the information electronically accessible and agrees with the need to move in that direction, inspectors need the information at the time of inspection and in a form that is readily reviewable. This allows for better analysis and review of the changes that have been made over time. Inspectors need to be able to review the changes before they begin their inspection of the device. Inspectors shouldn't be expected to provide the equipment necessary for retrieval of the information, and the use of foreign storage devices to retrieve the information would likely be a security issue for some jurisdictions. She also noted that reviewing a history of changes on a cell phone would be difficult because of the limited display size. A printed log of the changes is needed to enable a review of the changes made over time.

Mr. Ross Andersen (New York, retired) stated the proposed changes are not needed and are already addressed in the public record laws of each state. Some questioned whether or not those laws apply to this type of record and suggested further examination of those laws is needed.

A few regulatory officials voiced concern regarding the equipment that would be needed to access the information and whether or not every official in every jurisdiction would have access to the equipment. An additional concern raised by officials is how secure the data would be if collected electronically. With respect to the security concern, it was suggested that perhaps equipment manufacturers could design their equipment in such a way to prevent uploads of data from occurring. Another suggestion was to possibly password encrypt the data. Comments in support of being able to access the data electronically were also heard. Ms. Kristin Macey (California) stated that we absolutely need the ability to provide information electronically; government will catch up.

Mr. Paul Lewis (Rice Lake Weighing) pointed out that officials typically only look at the sealable parameters that have changed since last inspecting the device. He reported, in his experience, that it's not all that much information.

The Committee agreed to replace the language originally proposed by the submitter with that shown in the "Item Under Consideration" and move this item forward for a Vote.



### 2015 NCWM Annual Meeting:

NCWM 2015 Annual Meeting: The Committee heard numerous comments in support of the proposal by both industry and officials. Several of those providing comment in support of the proposal acknowledged the need for weights and measures officials to begin recognizing the use of electronic information. There was also testimony received from several weights and measures officials expressing concern over installing an electronic device such as a thumb drive, flash drive, etc. into government computers due to IT restrictions and potential transfer of computer viruses. A representative of an electric vehicle fueling device manufacturer stated that the Category 3 event logger information should only be required to be available electronically and the requirement that a printed copy be available through the device or another on-site device is archaic.

With respect to the concerns raised over installing an electronic device into government computers, Ms. Angela Godwin (Ventura County Department of Weights and Measures, California) offered one possible solution. She reported there are dedicated devices available in the marketplace capable of receiving digital storage devices that cost approximately \$200.00.

Ms. Butcher commented that OWM understands and supports the concept of eventually allowing required information to be made available electronically, but only if provisions are in place to make that information readily accessible. She noted that event logger information is used by officials to determine possible device manipulation. For this reason, the information needs to be made readily available to the official in hard copy at the time of inspection and in a format that is readily reviewable so changes that have been made over time are evident.

Ms. Butcher further commented that inspectors should not be expected to provide the equipment necessary to view the information. That equipment needs to be supplied by the owner/operator of the device, as is currently the case. As noted in OWM's comments at the 2015 Interim Meeting:

- Inspectors don't universally have access to the equipment needed to receive the event logger information onsite; and in many cases they would not be permitted to install a "foreign" storage device into a government issued computer, due to security reasons.
- Reviewing a history of changes using a cell phone or other device with a limited display would be very difficult. A printed log will typically better enable an inspector to review a device's history and determine the changes that have been made over time.
- Some of the Regional Weights and Measures Associations and the Measuring Sector have noted these same concerns.

Ms. Butcher noted that since the current requirement does not does not prohibit supplying the information electronically in addition to the hard copy, OWM believes the proposed changes are unnecessary and may cause undue confusion. Based on input from 2015 spring regional weights and measures association meetings, the language proposed seems to already be causing unnecessary confusion to an otherwise clear and straightforward requirement. Some are interpreting the changes to mean the event logger information can be solely provided electronically. OWM recommends that should the Committee still believe changes to the paragraph are necessary, the following alternative language, which makes clearer the need to provide the information in hard copy at time of inspection, should be considered:

*An event logger is required in the device; it must include an event counter (000 to 999), the parameter ID, the date and time of the change, and the new value of the parameter. A printed copy of the information must be available on demand through the device or through another on-site device. In addition to providing a printed copy of the information, the information may be made available electronically. The event logger shall have a capacity to retain records equal to 10 times the number of sealable parameters in the device, but not more than 1000 records are required. (Note: Does not require 1000 changes to be stored for each parameter.)*

Not everyone agreed with OWM's assertion that the proposed changes would cause confusion. Mr. Ron Hasemeyer (Alameda County Department of Weights and Measures, California) commented that the changes proposed would

still require the information be provided in hard copy. Other officials commented in support of Mr. Hasemeyer's interpretation noting that the words "must be available on demand" (as shown in the Item Under Consideration) and make clear that the information must be made available in hard copy at time of inspection, if requested.

The Committee, in considering the testimony received during the Open Hearings, agreed the changes being proposed should not lead to confusion. That is the Committee agreed the words "must be available on demand" could only be interpreted to mean that the event logger information must be available in printed form at the time of inspection. Thus, the Committee agreed to recommend the item be presented for Vote as shown in the Item Under Consideration.

#### **Regional Association Meetings:**

**CWMA 2014 Interim Meeting:** This item did not appear on the CWMA's S&T Agenda at the 2014 CWMA Interim Meeting, but did appear on the agenda at the 2015 CWMA Annual Meeting. During the CWMA S&T Committee's Open Hearings, Mr. Gordon Johnson (Gilbarco) gave a brief history of this item. Comments were received from industry supporting the item. Ms. Julie Quinn (Minnesota) voiced concern with potential manipulation of the software data. Ms. Fran Elson Houston (Ohio) commented the same software could potentially manipulate the printed receipt as well. The CWMA agreed to recommend the item move forward as a Voting item.

Testimony was presented by the submitter during the 2014 WWMA Annual Meeting with no opposing opinions being presented. The WWMA S&T Committee felt that the item had merit and would more easily facilitate examination of an audit trail. However, there are some concerns with respect to data security and the transfer of information to weights and measures officials. Therefore, the WWMA forwarded the item to NCWM, recommending that it be a Developing item to allow the submitter to refine the proposal.

**SWMA 2014 Annual Meeting:** The SWMA reported that it supported the general concept of this item, but believes it needs to be further developed by the submitter. Specifically, concerns were raised regarding corruption of files, violation of government IT policies pertaining to foreign devices interacting with government computers, and input by other manufacturers. The SWMA forwarded the item to the NCWM, recommending it as a Developing item.

#### **Measuring Sector Actions:**

The Measuring Sector considered this item during its 2014 meeting (2014 Measuring Sector Agenda Item 16) and decided that this proposal needs further development and agreed to carry it over to its 2015 Agenda.

Additional letters, presentations, and data may have been part of the Committee's consideration. To review the supporting documentation, please refer to the *Report of the 99<sup>th</sup> National Conference on Weights and Measures* (SP1193, 2014).

### **330-3 W N.4.1.3. Normal Tests on Wholesale Multi-Point Calibration Devices.**

(This item was Withdrawn.)

#### **Source:**

NCWM Multi-Point Calibration Group (MPCG) (2015)

#### **Purpose:**

Update the Liquid Measuring Device Code to reflect advances in meter calibration technology.

#### **Item Under Consideration:**

Add a new paragraph to the NIST Handbook 44 Liquid Measuring Devices Code as follows:

**N.4.1.3. Normal Tests on Wholesale Multi-Point Calibration Devices. – The normal test of a wholesale liquid-measuring device with electronically programmed linearization factors for various flow rates shall be made at the maximum discharge rate developed by the installation. Any additional tests conducted at flow rates down to and including the rated minimum discharge flow rate shall be considered normal tests.**

**Background/Discussion:**

New technology makes it possible to use linearization factors to optimize accuracy at every flow rate for which a wholesale meter is programmed to deliver. A special tolerance has traditionally been applied to slow flow tests on wholesale meters with mechanical single-point calibrators because accuracy could only be optimized at one flow rate. A wholesale multi-point calibrated meter does not require a special tolerance at any flow rate since every flow rate can be adjusted as close to zero as practicable.

This supports the principle expressed in G-UR.4.3. that adjustments shall be made so as to bring performance errors as close to zero as possible. It also reduces the amount of bias error, which startup and shutdown rates introduce into the proving process, by reducing performance errors at slow-flow startup and shutdown flow rates. The proposed paragraph N.1.4.3. would apply only to meters that are actually configured with multiple calibration points. Meter owners who do not want to take the time to calibrate at multiple flow rates may configure their meters for single point calibration.

This allows meters with single point calibration to have a larger tolerance at slow-flow rates than meters with multi-point calibration. Multi-point calibrated devices are increasingly used as commercial meters. The question of whether they should be treated differently than devices with single-point calibration needs to be addressed.

**2015 NCWM Interim Meeting:**

NCWM 2015 Interim Meeting: Agenda Items 330-3, 331-1, and 360-2 were grouped together and comments taken simultaneously since the Committee considered them related. A summary of comments heard on all three items are as follows:

With respect to Agenda Item 330-3, Ms. Tina Butcher (NIST, OWM) stated that there appears to be a “structural issue” and potential conflict with N.4.1.3. She provided a brief summary of OWM’s analysis of this item (shown below), which was provided to Committee members in a written report and made available to the NCWM membership during the Open Hearings.

*NIST OWM’s Analysis of Agenda Item 330-3*

Additional work is needed on this proposal. In considering this item, NIST, OWM identified the following issues that will need to be addressed:

- The second sentence of proposed new paragraph N.4.1.3. conflicts with the second sentence of current paragraph N.4.1. Normal Tests. Given this conflict, how can the code best be structured to accommodate the addition of this new proposed requirement? That is, what should the paragraph hierarchy look like and will current requirements need to be changed to avoid conflicts and added confusion?
- Why does the proposal limit tests to wholesale devices? OWM questions why this principle wouldn’t apply to any measuring device with multi-point calibration capability?
- Should Table T.2. be amended to make clear the tolerance intended to apply to the results of all the testing that will need to be conducted on devices with multi-point calibration?
- Paragraph N.4.2. Special Tests specifies that a “Special Test” shall be made; yet, OWM believes that the multi-calibration group intends for all testing associated with a device equipped with multi-point calibration be “Normal” tests and “Normal” test tolerances intended to apply. If this is the case, how are officials to meet the obligation of performing a “Special Test” as specified?

How will the addition of this new paragraph affect other paragraphs in the code? All current paragraphs should to be reviewed to make certain additional conflicts or confusion isn’t being created by the addition of any new paragraph.

With respect to Agenda Item 331-1, Ms. Butcher noted that NIST, OWM’s analysis and comments for the item are the same those made in NCWM S&T Item 330-3. However, it is important to point out that the language proposed was copied and pasted from NCWM S&T Item 330-3 and then modifications of terms from “wholesale” to “vehicle-tank” were made. The reference to “wholesale” multi-point calibrated devices was overlooked in several places and remains in this item. Consequently, there are multiple corrections that must be made to change references from “wholesale” to “vehicle-tank” or “vehicle-tank meter” as appropriate. In that regard, the following amendments are needed:

1. Amend the proposal’s NCWM Publication 15 heading to read: “331-1 N.4.1.4. Normal Tests on ~~Wholesale~~ Vehicle-Tank Multi-Point Calibration Devices.”
2. Amend the “Purpose” statement to read: “Update the ~~Liquid Measuring Device~~ Vehicle-Tank Meter Code to reflect advances in meter calibration technology.”
3. Amend the Item Under Consideration statement to read: “Add a new paragraph to the NIST Handbook 44 ~~Liquid Measuring Devices~~ Vehicle-Tank Meter Code as follows:”
4. Amend the proposal’s reference title to read: “N.4.1.4. Normal Tests on ~~Wholesale~~ Vehicle-Tank Multi-Point Calibration Devices.”

With respect to Agenda Item 360-2, Ms. Butcher provided a brief summary of OWM’s analysis of this item, which was also provided to Committee members in a written report and made available to the NCWM membership during the Open Hearings. The following analysis was provided:

*OWM’s analysis of Agenda Item 360-2:*

If adopted, NCWM S&T Item 360-2 would do the following:

1. it would include citations to NIST Handbook 44, Sections 3.31., 3.32, 3.34., and 3.35. into the definition of “calibration parameter;” and
2. it would add a definition for “multi-point calibrated device.”

The term “calibration parameter” is used in the *Categories of Device and Methods of Sealing* tables in NIST Handbook 44, Sections 3.31., 3.32., 3.34., and 3.35., but these Sections are not currently cited in the definition of calibration parameter. NIST OWM believes that for consistency and correctness it is appropriate that these references be added to this definition.

The term “multi-point calibrated device” does not currently appear in NIST Handbook 44, and for that reason, it would not be appropriate to add a definition unless one or more of the proposals related to multiple-point calibration are adopted. If this were to occur, then a definition would be necessary.

In the “Background/Discussion” portion of this item, there are comments that other equipment “such as meters, weighing devices, and other devices” has the capability of multiple-point calibration. This may be true; however, the term, “multi-point calibrated device” is not used in any of the current NIST Handbook 44 codes. Thus, NIST, OWM believes this definition is not necessary.

Due to the similar context, intent, and companionship of NCWM S&T Committee Agenda Items 330-3, 330-4, 331-1, 331-2, and 360-2, NIST, OWM recommends that all of these items be heard and discussed by the Conference at the same time.

- (1) Mr. Henry Oppermann (Weights and Measures Consulting, LLC) provided written comments to the Committee in opposition to Agenda Items 330-3 and 331-1 and provided a summary of his concerns during the Open

Hearings. He stated these items were against some weights and measures principles, and the existing tolerances for these devices are acceptable. The proposal would have the effect of changing NIST Handbook 44 tolerances by considering flow rates down to the minimum discharge rate of meter to be normal tests on multi-point calibration devices. This is wrong because:

1. Accuracy requirements (tolerances) are established based on the accuracy that is required for a particular application of the devices at a reasonable cost.
  2. The tolerances for a given measurement application are **not** based upon the technologies used in devices.
  3. Any device that meets the specifications and tolerances for a given application may be used for that application.
  4. It is wrong to penalize a technology with tighter tolerances simply because it can produce more accurate measurements than other technologies used in the same application.
- (2) Mr. Oppermann also noted that weights and measures officials, industry representatives, and users of weighing and measuring devices work together to establish acceptable tolerances for different applications based upon the fundamental consideration stated above. If changes to tolerances are considered, then the changes should apply to all devices and device technologies used in the application of interest. If weights and measures jurisdictions deviate from the principles stated above, then different tolerances could be established for positive displacement meters, turbine meters, and mass flow meters used in the same applications. Similarly, different tolerances could be proposed for mechanical versus load cell vehicle scales. This would be unnecessary and wrong. Tolerances for devices must be based upon what is considered acceptable for the application. Favoring or penalizing one technology or design over another is unacceptable.

Mr. Constantine Cotsoradis (Flint Hills Resources), a member of the multi-point calibration WG, stated this was an issue of a “Special Test” versus a “Normal Test” and puts the burden on the user.

Mr. Ross Andersen (New York, Retired) suggested that the “Fundamental Considerations” in NIST Handbook 44 needed to be fixed to address calibration drift. He stated meters operate in an environment, and it needs to be recognized that meter performance is affected by temperature, product viscosity, and other factors. He further noted that if you test the same meter once a week for an entire month, it will provide different results. Mr. Andersen agreed with Mr. Oppermann’s assessment that calibration curves change due to drift.

Mr. Dick Suiter (Richard Suiter Consulting) stated that if a meter with multi-point calibration is used, then weights and measures officials need to look at multiple points. Ms. Julie Quinn (Minnesota), Chair of the MPCG, requested this item remain in Developing status because a consensus within the MPCG has not been achieved. Mr. Dmitri Karimov representing the Meter Manufacturer’s Association and a member of the MPCG added that the MPCG also discussed the length of time for testing, which is also a concern.

The SMA reported that it opposed the definition of multi-point calibrated device and offered the following alternative for consideration:

**Multi-point calibration.** – A means to electronically program calibration factors at multiple measurement points.

The Committee agreed this item should move forward as a Developing item based on the comments received and the submitter’s recommendation that it remain Developing because additional work is needed.

#### **2015 NCWM Annual Meeting:**

NCWM 2015 Annual Meeting: The Committee agreed to group together Agenda Items 330-3, 331-1, and 360-2 and take comments on these items simultaneously. Mr. Russ Vires (Mettler-Toledo, LLC) speaking on behalf of the SMA reported that the SMA is opposed to the definition being proposed for “multi-point calibrated device” in Agenda Item 360-2. Ms. Quinn, submitter of all the items in the group recommended Items 330-3 and 331-1 be Withdrawn

in their entirety. She also recommended that the Committee delete the definition of “multi-point calibrated device” in Agenda Item 360-2 and maintain its Developing status because further updates to the NIST Handbook 44 Code references within the current NIST Handbook 44 definition of “calibration parameter” are planned.

Hearing no comments in support of Agenda Items 330-3 and 331-1 and a recommendation by the submitter to Withdraw them, the Committee agreed to Withdraw these items. The Committee also agreed to delete the proposed definition of “multi-point calibrated device” from Agenda Item 360-2 and maintain its Developing status to allow the submitter of the item additional time to develop the proposal.

**Regional Association Comments:**

**CWMA 2014 Interim Meeting:** The CWMA received a presentation to clarify the purpose of this item. A regulatory official voiced support for this item. The CWMA appreciates the efforts of the WG and believes this item is sufficiently developed. The CWMA forwarded the item to the NCWM, recommending it as a Voting item. At the 2015 CWMA Annual Meeting, there were no comments received on this item. The CWMA agreed to recommend the item move forward as a Developing item, noting that it supported its continued development.

**WWMA 2014 Annual Meeting:** Testimony was presented at the 2014 WWMA Annual Meeting by a member of the MPCG, stating that the item is fully developed and ready to be a Voting item. No opposition was heard during open hearing and the WWMA agreed that the item was sufficiently developed and forwarded it to NCWM, recommending that the item be a Voting item.

**SWMA 2014 Annual Meeting:** The SWMA S&T Committee recommended the item be Withdrawn based on concerns that, if adopted, it would result in extensive additional work required by inspectors; increased downtime for businesses; questionable gain when compared to existing tolerances; and result in the approval of devices for each product type. The SWMA doesn’t believe the handbooks are the proper place for examples. Based on the SWMA S&T Committee’s recommendation, the SWMA did not forward this item to the NCWM; recommending instead that it be Withdrawn.

**NEWMA 2014 Interim Meeting:** NEWMA combined Agenda Items 330-3, 331-1, and 360-2 into one agenda item. NEWMA reported it believes the item has merit, but required more information before any further judgment could be made on it. NEWMA forwarded the item to the NCWM and recommended that it be an Information item. NEWMA agreed to combine Agenda Items 360-2, 330-3, and 331-1 at its 2015 Annual Meeting and recommend this item move forward as a Developing item as the MPCG amends language in the proposal.

Additional letters, presentations, and data may have been part of the Committee’s consideration. To review the supporting documentation, please refer to the *Report of the 99<sup>th</sup> National Conference on Weights and Measures* (SP1193, 2014).

**330-4 D N.4.5. Determination of Error on Wholesale Devices with Multiple Flow Rates and Calibration Factors**

**Source:**

Minnesota Weights and Measures Division (2014)

**Purpose:**

To update NIST Handbook 44 to reflect the technological changes in registers for liquid measuring devices and to alert weights and measures officials to the fact that error in start-up and shut-down delivery quantities can introduce linear errors in the calibration at normal flow rates; these errors increase the further the delivered quantity deviates from the prover size used at calibration.

**Item Under Consideration:**

*(Note: This version of the proposal was added at the request of the submitter during the 2015 NCWM Annual Meeting and replaces previous versions of the proposal.)*

Amend NIST Handbook 44, Liquid-Measuring Devices Code as follows:

**N.4.5. Verification of Linearization Factors. – All enabled linearization factors shall be verified when a device:**

- (a) is initially being put into commercial use;**
- (b) has been placed into service and is officially being tested for the first time;**
- (c) is being returned to commercial service following official rejection for failure to conform to performance requirements and is being officially tested for the first time after corrective service;**
- (d) is being officially tested for the first time after major reconditioning or overhaul; or**
- (e) at the discretion of the official with statutory authority.**

**The verification of enabled linearization factors may be done through physical testing or empirical analysis.**

**UR.4. Maintenance Requirements.**

**UR.4.1. Use of Adjustments. – Whenever devices are adjusted, all enabled linearization factors shall be verified through physical testing or empirical analysis to determine that the errors are in tolerance and any adjustments which are made, shall be made so as to bring performance errors as close as practicable to zero value.**

**Background/Discussion:**

Wholesale metering systems are used to deliver product at many different flow rates. Many of these systems are equipped with features that allow different calibration factors to be programmed at those flow rates. Companies commonly set accuracy goals of  $\pm 0.05\%$  at normal and “fallback” delivery rates; however, they are often reluctant to spend time entering different calibration factors for the initial (“start-up”) and ending (“shut-down”) portions of the delivery. Spending time calibrating the metering system at normal and fallback delivery rates to such a high degree of accuracy is wasted if the error introduced into the measurement by the start-up and shut-down quantities is unknown. An additional concern is that an unscrupulous operator could use the error introduced by the start-up and shut-down portions of the delivery (if known) to adjust calibration at the normal delivery rate such that the overall error of a typical delivery is predominantly in the user’s favor. Officials should be aware that when delivered quantities are greater than the prover used at calibration, start-up and shutdown errors have a counter-intuitive effect. Underregistration errors (which are normally in the consumer’s favor) in the start-up and shut-down portions of the delivery may actually create shortages in the total delivery if calibration at the normal flow rate is adjusted to compensate for that underregistration. While these errors should be well within tolerance if the start-up and shut-down errors are in tolerance, an official who is trying to determine predominance of error should be aware of this effect and know how to determine the expected error in a typical delivery. Operators need to understand the importance of knowing and accounting for the effects of start-up and shut-down errors. Officials need to be aware of the potential for misusing that knowledge. Terminals and refineries want to maximize the accuracy of their liquid measuring devices by optimizing the calibration factors at typical delivery rates.

This proposal is not intended to have any effect on locations that do not use electronic calibration factors to optimize accuracy at every delivery rate. Even at locations which do use multiple calibration factors, no action is required unless the official notices the error for the start-up and shut-down rates is predominantly in one direction. If the start-up and shut-down errors are predominantly in one direction, the official then needs to determine the size of a typical transaction and the likely predominance of the error. Device owners can easily ensure they have no problems with this requirement by making sure their devices are in tolerance at slow flow start-up and shut-down rates and errors are not predominantly in one direction.

See Appendix D in this report, “How Slow Flow Accuracy Affects LMDs” for additional background information related to this proposal.

See the 2014 S&T Committee's Annual Report to review previous language and positions regarding the proposed addition of Paragraphs N.4.2.5. Initial Verification and UR. 2.5.1. Initial Verification Proving Reports to NIST Handbook 44, Liquid-Measuring Devices Code.

**2015 NCWM Interim Meeting:**

NCWM 2015 NCWM Interim Meeting: The Committee considered the following proposal to add two new paragraphs to NIST Handbook 44, Liquid-Measuring Devices Code:

**N.4.2.5. Initial Verification. – A wholesale liquid measuring device shall be tested at all flow rates and with all products for which a calibration factor has been electronically programmed prior to placing it into commercial service for the first time or after being repaired or replaced.**

**A wholesale liquid measuring device not equipped with means to electronically program its flow rates and calibration factors shall be tested at a low and high flow rate with all products delivered prior to placing it into commercial service for the first time or after being repaired or replaced.**

**Example: A meter is electronically programmed to deliver regular and premium gasoline at a startup/shutdown flow rate of 150 gpm, a normal operating flow rate of 650 gpm, and a fall-back rate of 450 gpm. The meter is to be tested with regular gasoline at 150 gpm, 450 gpm and 650 gpm; and with premium gasoline at 150 gpm, 450 gpm and 650 gpm.**

**The official with statutory authority has the discretion to determine the flow rates and products at which a meter will be tested on subsequent verifications.**

**UR.2.5.1. Initial Verification Proving Reports. – Initial verification proving reports for wholesale liquid measuring devices equipped with means to electronically program flow rates shall be attached to and sent with placed-in-service reports when the regulatory agency with statutory authority requires placed-in-service reports.**

The Committee decided to group together Items 330-4 and 331-2 and comments were taken simultaneously on those items since the Committee considered them companion items. Ms. Julie Quinn (Minnesota), speaking as Chair of the MPCG, stated that the MPCG received comments indicating there are concerns regarding the amount of time it would take to test multi-point calibration devices if this item were adopted. She recommended the item remain Developmental and stated that the MPCG may wish to consider the Canadian model in addressing devices equipped with multi-point calibration.

Ms. Tina Butcher (OWM) acknowledged that to verify the performance of a meter with multi-point calibration completely, separate tests must be performed with each product that will be metered and at all flow rates and every calibration factor that has been programmed into the system for those products. This makes obvious the need to perform many tests on a single meter in order to take into account the different factors and combinations thereof, affecting performance. She reported OWM questions, however, whether it is reasonable to expect all regulatory jurisdictions be equipped with the resources necessary to perform the extensive amount of testing required by this proposal. OWM believes some jurisdictions are likely to consider this practice onerous, and consequently, may not be willing or capable of performing the amount of testing prescribed. OWM also questions whether device owners would be receptive to the amount of time a device would need to be taken out of service in order to complete the testing. Ms. Butcher also summarized the following list of issues that OWM had identified in its analysis of this item as needing additional work to further develop the proposal:

- Why limit this concept of testing multi-point calibration devices to LMDs and to only those LMDs being used in a wholesale application? Other types of equipment, both wholesale and retail, including scales, vehicle tank meters, etc., have multi-point calibration. Perhaps there should be a General Code requirement that addresses this issue for all types of devices.



- Did the MPCG consider statistical sampling to reduce the number of tests required when developing this proposal? Might some form of statistical sampling plan be developed that provides an indication of the level (or amount) of testing required in a given population of devices?
- Might such detailed procedures be better suited for inclusion in a NIST EPO?
- It is not clear what is meant by “all products” in the proposal. Is this to mean every grade of product? If the intent is to require every grade of every product, this would conflict with current NTEP evaluation policy.
- If it is the intent of the MPCG to classify the testing to be performed on a device with multi-point calibration as “Normal” tests opposed to “Special” tests (which is NIST, OWM’s understanding) then positioning this new paragraph beneath N.4.2. Special Tests and assigning it the designation “N.4.2.5.” would be inappropriate.
- The title of the proposed paragraph, “Initial Verification,” conflicts with the following words contained in the first sentence of the paragraph: “or after being repaired or replaced.”

Mr. Oppermann provided the Committee a written analysis of these items, which he summarized as follows:

The test procedures proposed in Agenda Items 330-4 and 331-2 are directed to service companies placing meters into service and HB 44 is the wrong place for instructions to service companies regarding how devices are to be placed into service. The “Notes” section of these two device codes (LMD and VTM) already permits officials to conduct any additional tests that they deem necessary to determine the performance characteristics of the meters being tested. Each NIST EPO describes the minimum examination for official action. The EPOs provide officials the necessary latitude to conduct additional tests or to repeat any or all tests as part of the examination process. He also stated that the term “initial verification” is used incorrectly in the proposal to apply to tests performed by service company representatives when placing meters into service. Initial verification applies to the first inspection and test conducted by weights and measures officials on a new weighing or measuring device.

Ms. Quinn commented the term “initial verification” is meant to refer to devices being tested for the first time.

In consideration of the comments provided during the Open Hearings and the recommendation provided by the Chair of the WG that the item remain in a Developing status, the Committee agreed to assign this item a Developing status.

#### **2015 NCWM Annual Meeting:**

NCWM 2015 Annual Meeting: The Committee agreed to group together Agenda Items 330-4 and 331-2 and take comments simultaneously on these two items. During the Open Hearings, Ms. Quinn, submitter of the two items, asked that the language in the proposal considered by the Committee at the 2015 Interim Meeting be replaced with a revised version. Ms. Quinn noted that she had conducted a meeting on Sunday, July 19, 2015, with a group that included several meter manufacturers to consider the two proposals and, during this meeting, the group developed the revised version of the proposal. Based on Ms. Quinn’s recommendations, the Committee agreed to replace the previous proposal with that shown in the “Item Under Consideration” above.

An industry representative, who is also a member of the group that helped develop the proposal voiced support of the changes proposed by Ms. Quinn.

Mr. Ross Andersen (New York, retired), in considering the new proposal recommended by Ms. Quinn, commented that only part (e) of proposed new paragraph N.4.5. Verification of Linearization Factors is needed. Officials must decide which factors are to be tested or what testing is needed.

Ms. Tina Butcher acknowledged the progress made by the group working on the multi-point calibration issue. She indicated additional work is needed with respect to abbreviating the testing needed to verify the performance of a metering system with multi-point calibration capabilities. She also indicated detailed procedures might be better suited

to inclusion in a NIST EPO, rather than NIST Handbook 44. In a written analysis of the item provided to the Committee, OWM reiterated the following points presented at the 2015 NCWM Interim Meeting:

- OWM acknowledges that to verify the performance of a meter with multi-point calibration completely, separate tests must be performed with each product that will be metered and at all flow rates and every calibration factor that has been programmed into the system for those products. This makes obvious the need to perform many tests on a single meter in order to take into account the different factors, and combinations thereof, affecting performance.
- OWM questions, however, whether it is reasonable to expect that all regulatory jurisdictions be equipped with the resources necessary to perform the extensive amount of testing required by this proposal. OWM believes that some jurisdictions are likely to consider this practice onerous and, consequently, may not be willing or capable of performing the amount of testing prescribed. OWM also questions whether device owners would be receptive to the amount of time a device would need to be taken out of service in order to complete the testing.
- In considering this item, OWM identified a number of issues that indicate additional work would be needed to further develop this proposal. The following issues were identified:
  - Why limit this concept of testing multi-point calibration devices to LMDs and to only those LMDs being used in a wholesale application? Other types of equipment, both wholesale and retail, including scales, vehicle tank meters, etc., have multi-point calibration. Perhaps there should be a General Code requirement that addresses this issue for all types of devices.
  - Did the MPCG consider statistical sampling to reduce the number of tests required when developing this proposal? Might some form of statistical sampling plan be developed that provides an indication of the level (or amount) of testing required in a given population of devices?
  - Might such detailed procedures be better suited for inclusion in a NIST EPO?
  - It is not clear what is meant by “all products” in the proposal. Is this to mean every grade of product? If the intent is to require every grade of every product, this would conflict with current NTEP evaluation policy.
  - If it is the intent of the MPCG group to classify the testing to be performed on a device with multi-point calibration as “Normal” tests opposed to “Special” tests (which is OWM’s understanding), then positioning this new paragraph beneath N.4.2. Special Tests and assigning it the designation “N.4.2.5.” would be inappropriate.
  - The title of the proposed paragraph, “Initial Verification,” conflicts with the following words contained in the first sentence of the paragraph: “or after being repaired or replaced.”
  - What is meant by “repaired” in the first sentence? When using this term, did the MPCG consider the definition of “repaired device” in NIST Handbook 44 or the examples of a “repaired device” that were developed by the NCWM Remanufactured Device Task Force in 2000?
  - How much testing would be required on a return (callback or reexamination) inspection if a device exceeded tolerance on only one of the initial tests (i.e., one product, flow rate, and calibration factor) when all other initial tests of the same meter (using same or different products at different flow rates and calibration factors) proved accurate? No guidance has been provided on how much testing would be needed on a callback or re-inspection visit (i.e., following repair).
  - Should the word “and” replace the word “or” in the first sentence? OWM believes the testing described is intended to apply to equipment put into commercial service the first time; equipment that has been

adjusted; and equipment installed to replace another piece of equipment. If that's the case, the word "and" should be used.

The Committee agreed to replace the previously proposed language with that recommended by Ms. Quinn during the Open Hearings and the new language is now shown in the "Item Under Consideration." The Committee looks forward to future refinements of this item by the submitter:

**Regional Association Meetings:**

CWMA 2014 Interim Meeting: The CWMA received a presentation at the meeting, to clarify the purpose of this item. A regulatory official voiced support for this item. The CWMA agreed the item was sufficiently developed and recommended that it be a Voting item as amended below:

~~***N.4.2.5. Determination of Error on Whole Sale Devices with Multiple Flow Rates and Calibration Factors-Initial Verification.** – On whole sale devices which are configured with multiple flow rates where each flow rate has its own calibration factor, and which are programmed to deliver a set quantity at a slow flow rate on start up and/or shut down, the effect of start up and shut down rates on the accuracy—the typical delivery shall be considered if the typical delivery is greater or less than the test measure used at the time of evaluation. The weights and measures jurisdiction shall determine the size of the typical delivery based upon available evidence. A wholesale liquid measuring device shall be tested at all flow rates and with all products for which a calibration linearization factor has been electronically programmed prior to placing it into commercial service for the first time or after being repaired or replaced.*~~

*A wholesale liquid measuring device not equipped with means to electronically program its flow rates and calibration linearization factors shall be tested at a low and high flow rate with all products delivered prior to placing it into commercial service for the first time or after being repaired or replaced.*

*Example: A meter is electronically programmed to deliver regular and premium gasoline at a startup/shutdown flow rate of 150 gpm, a normal operating flow rate of 650 gpm, and a fall-back rate of 450 gpm. The meter is to be tested with regular gasoline at 150 gpm, 450 gpm and 650 gpm; and with premium gasoline at 150 gpm, 450 gpm and 650 gpm.*

*The official with statutory authority has the discretion to determine the flow rates and products at which a meter will be tested on subsequent verifications.*

*UR.2.5.1. Initial Verification Proving Reports.* – Initial verification proving reports for wholesale liquid measuring devices equipped with means to electronically program flow rates shall be attached to and sent with placed- in-service reports when the regulatory agency with statutory authority requires placed-in-service reports.

CWMA 2015 Annual Meeting Open Hearings: Ms. Julie Quinn (Minnesota), submitter of the item, reported that a WG is still Developing the item. Consequently, the CWMA agreed to recommend the item move forward as a Developing item noting support for its continued Development.

Testimony was presented at the 2014 WWMA Annual Meeting by a member of the MPCG, stating that the item is fully developed and ready to be a Voting item. No opposition was heard during the Open Hearings and the WWMA agreed that the item was sufficiently developed and recommended that it be a Voting item as amended below:

**N.4.1.3,N.4.2.5. Initial Verification.**

- (a) A wholesale liquid measuring device shall be tested at all flow rates and with all products for which a calibration linearization factor has been electronically programmed prior to placing it into commercial service for the first time or after being repaired or replaced.**

**(b) A wholesale liquid measuring device not equipped with means to electronically program its flow rates and calibration linearization factors shall be tested at a low and high flow rate with all products delivered prior to placing it into commercial service for the first time or after being repaired or replaced.**

~~**Example: A meter is electronically programmed to deliver regular and premium gasoline at a startup/shutdown flow rate of 150 gpm, a normal operating flow rate of 650 gpm, and a fall back rate of 450 gpm. The meter is to be tested with regular gasoline at 150 gpm, 450 gpm and 650 gpm; and with premium gasoline at 150 gpm, 450 gpm and 650 gpm.**~~

**The official with statutory authority has the discretion to determine the flow rates and products at which a meter will be tested on subsequent verifications.**

**UR.2.6.UR.2.5.1. Initial Verification Proving Reports. – Initial verification proving reports for wholesale liquid measuring devices equipped with means to electronically program flow rates shall be attached to and sent with placed-in-service reports when the regulatory agency with statutory authority requires placed-in-service reports.**

SWMA 2014 Annual Meeting: The SWMA S&T Committee recommended the item be withdrawn based on concerns that, if adopted, it would result in extensive additional work required by inspectors; increased downtime for businesses; questionable gain when compared to existing tolerances; and the approval of devices for each product type. The Committee doesn't believe the handbooks are the proper place for examples. Based on the SWMA S&T Committee's recommendation, the SWMA did not forward this item to the NCWM; recommending, instead, it be Withdrawn.

NEWMA 2014 Interim Meeting: NEWMA did not receive comments on this item at its Interim Meeting and recommended that the item be Withdrawn. At its 2015 Annual Meeting NEWMA did not receive comments but changes its earlier position on this item recommending it be given a Developing status pending further information.

Additional letters, presentations, and data may have been part of the Committee's consideration. To review the supporting documentation, please refer to the *Report of the 99<sup>th</sup> National Conference on Weights and Measures* (SP1193, 2014).

### 331 VEHICLE-TANK METERS

#### 331-1 W N.4.1.4. Normal Tests on Wholesale Multi-Point Calibration Devices.

(This item was Withdrawn.)

**Source:**

NCWM Multi-Point Calibration Group (MPCG) (2015)

**Purpose:**

Update the Liquid Measuring Device Code to reflect advances in meter calibration technology.

**Item Under Consideration:**

Add a new paragraph to the NIST Handbook 44, Liquid Measuring Devices Code as follows:

**N.4.1.4. Normal Tests on Wholesale Multi-Point Calibration Devices. – The normal test of a vehicle tank meter with electronically programmed linearization factors for various flow rates shall be made at the maximum discharge rate developed by the installation. Any additional tests conducted at flow rates down to and including the rated minimum discharge flow rate shall be considered normal tests.**

**Background/Discussion:**

New technology makes it possible to use linearization factors to optimize accuracy at every flow rate for which a vehicle-tank meter is programmed to deliver. A special tolerance has traditionally been applied to slow flow tests on vehicle-tank meters with mechanical single-point calibrators because accuracy could only be optimized at one flow rate. A vehicle-tank multi-point calibrated meter does not require a special tolerance at any flow rate since every flow rate can be adjusted as close to zero as practicable.

This supports the principle expressed in G-UR.4.3. that adjustments shall be made so as to bring performance errors as close to zero as possible. It also reduces the amount of bias error that startup and shutdown rates introduce into the proving process by reducing performance errors at slow-flow startup and shutdown flow rates. The proposed paragraph N.4.1.4. would apply only to meters that are actually configured with multiple calibration points. Meter owners who do not want to take the time to calibrate at multiple flow rates may configure their meters for single point calibration.

This allows meters with single point calibration to have a larger tolerance at slow-flow rates than meters with multi-point calibration. Multi-point calibrated devices are increasingly used as commercial meters. The question of whether they should be treated differently than devices with single-point calibration needs to be addressed.

**2015 NCWM Interim Meeting:**

NCWM 2015 Interim Meeting: Agenda Items 330-3, 331-1, and 360-2 were grouped together and comments taken simultaneously since the Committee considered them related. See Agenda Item 330-3 for a summary of the comments heard on all three of these agenda items.

The Committee agreed this item should move forward as a Developing item based on the comments received and the submitter’s recommendation that it remain Developing because additional work is needed.

**2015 NCWM Annual Meeting:**

NCWM 2015 Annual Meeting: The Committee agreed to group together Agenda Items 330-3, 331-1 and 3602 and take comments on these items simultaneously. Mr. Russ Vires (Mettler-Toledo, LLC) speaking on behalf of the SMA reported that the SMA is opposed to the definition being proposed for “multi-point calibrated device” in Agenda Item 360-2. Ms. Julie Quinn (Minnesota), submitter of all the items in the group recommended Items 330-3 and 331-1 be Withdrawn in their entirety. She also recommended the Committee delete the definition of “multi-point calibrated device” in Agenda Item 360-2 and maintain its Developing status because further updates to the NIST Handbook 44 Code references within the current NIST Handbook 44 definition of “calibration parameter” are planned.

Hearing no comments in support of Agenda Items 330-3 and 331-1 and a recommendation by the submitter to Withdraw them, the Committee agreed to withdraw these items. The Committee also agreed to delete the proposed definition of “multi-point calibrated device” from Agenda Item 360-2 and maintain its Developing status to allow the submitter of the item additional time to develop the proposal.

**Regional Association Meetings:**

CWMA 2014 Interim Meeting: CWMA heard a presentation at its Interim Meeting to clarify the purpose of this item. A regulatory official voiced support for this item. The CWMA appreciates the efforts of the WG and believes this item is sufficiently developed. The CWMA forwarded the item to the NCWM, recommending it as a Voting item. During the 2015 CWMA Annual Meeting, Ms. Quinn, submitter of the item, commented that the MPCG is still Developing the item. Consequently, the CWMA agreed to recommend the item move forward as a Developing item.

WWMA 2014 Annual Meeting: Testimony was presented at the 2014 WWMA Annual Meeting by a member of the MPCG, stating the item is fully developed and ready to be a Voting item. The item was amended to address concerns expressed during Open Hearings. No opposition was heard, and the WWMA agreed the item was sufficiently developed. The WWMA forwarded the item to NCWM and recommended it as a Voting item as amended below:

**N.4.1.4.N.4.1.3. Normal Tests on Wholesale Multi-Point Calibration Devices. – The normal test of a vehicle tank meter with electronically programmed linearization factors for various flow rates shall be**

**made at the maximum discharge rate developed by the installation. Any additional tests conducted at flow rates down to and including the rated minimum discharge flow rate shall be considered normal tests.**

SWMA 2014 Annual Meeting: The SWMA S&T Committee recommended the item be Withdrawn based on concerns that if adopted, it would result in extensive additional work required by inspectors; increased downtime for businesses; questionable gain when compared to existing tolerances; and result in the approval of devices for each product type. The SWMA doesn't believe the handbooks are the proper place for examples. Based on the SWMA S&T Committee's recommendation, the SWMA did not forward this item to the NCWM; recommending, instead, it be Withdrawn.

NEWMA 2014 Interim Meeting: NEWMA combined Agenda Items 330-3, 331-1, and 360-2 as one agenda item. NEWMA reported it believes the item has merit but required more information before any further judgment could be made on it. NEWMA forwarded the item to NCWM, recommending it as an Information item. NEWMA agreed to combine Agenda Items 360-2, 330-3, and 331-1 at its 2015 Annual Meeting and recommend this item move forward as a Developing item as the MPCG amends language in the proposal.

Additional letters, presentations, and data may have been part of the Committee's consideration. To review the supporting documentation, please refer to the *Report of the 99<sup>th</sup> National Conference on Weights and Measures* (SP1193, 2014).

### **331-2 D N.4.2.1. Determination of Error on Vehicle-Tank Meters with Multiple Flow Rates and Calibration Factors**

**Source:**

Minnesota Weights and Measures Division (2014)

**Purpose:**

To update NIST Handbook 44 to reflect the technological changes in registers for vehicle-tank meters and to alert weights and measures officials to the fact that error in start-up and shut-down delivery quantities can introduce linear errors in the calibration at normal flow rates which increase the further the delivered quantity deviates from the prover size used at calibration.

**Item Under Consideration:**

*(Note: This version of the proposal was added at the request of the submitter during the 2015 NCWM Annual Meeting and replaces previous versions of the proposal.)*

Amend NIST Handbook 44 Vehicle-Tanks Meter Code as follows:

**N.4.5. Verification of Linearization Factors. – All enabled linearization factors shall be verified when a device:**

- (a) is initially being put into commercial use;**
- (b) has been placed into service and is officially being tested for the first time;**
- (c) is being returned to commercial service following official rejection for failure to conform to performance requirements and is being officially tested for the first time after corrective service;**
- (d) is being officially tested for the first time after major reconditioning or overhaul; or**
- (e) at the discretion of the official with statutory authority.**

**The verification of enabled linearization factors may be done through physical testing or empirical analysis.**

**UR.4. Maintenance Requirements.**

**UR.4.1. Use of Adjustments. – Whenever devices are adjusted, all enabled linearization factors shall be verified through physical testing or empirical analysis to determine that the errors are in tolerance and any adjustments which are made, shall be made so as to bring performance errors as close as practicable to zero value.**

**Background/Discussion:**

Many terminals and refineries want to maximize the accuracy of their liquid-measuring devices by optimizing the calibration factors at typical delivery speeds and some bulk delivery companies are beginning to utilize the capabilities of electronic registers with multiple calibration factors to optimize their accuracy at flow rates that are customarily used. Just like registers on wholesale liquid measuring devices, these meters can be configured for a standard initial “start-up” and ending “shut-down” quantity delivered at a slower speed than is used for the remainder of the delivery. Service agents are expected to calibrate devices as close to zero as possible, but spending time calibrating normal delivery rates to a high degree of accuracy is wasted if the error introduced into the measurement by the start-up and shut-down quantities is unknown. On the other hand, an unscrupulous operator could also use the known error introduced by the start-up and shut-down errors to calibrate the normal delivery rates so that all the errors on typical deliveries work predominantly in the user’s favor. Officials should be aware that when delivered quantities are greater than the prover used at calibration, start-up and shut-down errors have a counter-intuitive effect. Underregistration, which normally operates in the consumers’ favor, may actually create shortages in the total delivery if calibration of the normal rate was adjusted to compensate for that underregistration. While these errors should be well within tolerance if the start-up and shut-down error are in tolerance, an official who is trying to determine predominance of error should be aware of this effect and know how to calculate the expected error in a typical delivery. Operators need to understand the importance of knowing and accounting for the effects of start-up and shut-down errors. Officials need to be aware of the potential for misusing that knowledge.

This proposal has no effect on locations that do not use electronic calibration factors to optimize accuracy at every delivery rate. Even at locations that do, no action is required unless the official notices the error for the start-up and shut-down rates is predominantly in one direction. If the start-up and shut-down errors are predominantly in one direction, the official then needs to determine the size of a typical transaction and the likely predominance of the error. Device owners can easily ensure that they have no problems with this requirement by making sure their devices are in tolerance at the slower start-up and shut-down flow rates and errors are not predominantly one way or the other.

See Appendix E, How Slow Flow Errors Affect VTMs.

See the 2014 S&T Committee’s Annual Report to review previous language and positions to add Paragraphs N.4.5. Initial Verification and UR. 2.5.1. Initial Verification Proving Reports to NIST Handbook 44, Vehicle-Tank Meters Code.

**2015 NCWM Interim Meeting:**

NCWM 2015 Interim Meeting: The Committee considered the following proposal to add two new paragraphs to NIST Handbook 44, Vehicle-Tank Meters Code:

**N.4.6. Initial Verification. – A vehicle tank meter shall be tested at all flow rates and with all products for which a calibration factor has been electronically programmed prior to placing it into commercial service for the first time or after being repaired or replaced.**

**A vehicle tank meter not equipped with means to electronically program its flow rates and calibration factors shall be tested at a low and high flow rate with all products delivered prior to placing it into commercial service for the first time or after being repaired or replaced.**

**Example: A vehicle tank meter is electronically programmed to deliver regular and premium gasoline at a startup/shutdown flow rate of 20 gpm, a normal operating flow rate of 100 gpm, and an intermediate rate of 65 gpm. The meter is to be tested with regular gasoline at 20 gpm, 65 gpm and 100 gpm; and with premium gasoline at 20 gpm, 65 gpm and 100 gpm.**

**The official with statutory authority has the discretion to determine the flow rates and products at which a vehicle tank meter will be tested on subsequent verifications.**

**UR.1.5. Initial Verification Proving Reports. – Initial verification proving reports for vehicle tank meters equipped with means to electronically program flow rates shall be attached to and sent with placed-in-service reports when the regulatory agency with statutory authority requires placed-in-service reports.**

The Committee grouped together Items 330-4 and 331-2 and comments were taken simultaneously since the Committee considered these to be companion items. For a summary of the comments provided during the Open Hearings, refer to Agenda Item 330-4. In consideration of the comments received, the Committee agreed to assign a Developing status to both of these items.

#### **2015 NCWM Annual Meeting:**

NCWM 2015 Annual Meeting: The Committee agreed to group together Agenda Items 330-4 and 331-2 and take comments simultaneously on these two items. For a summary of the comments received during the Open Hearings on these two agenda items, refer to Agenda Item 330-4. During the Open Hearings, Ms. Julie Quinn (Minnesota), submitter of the two items, asked that the language in the proposal considered by the Committee at the 2015 Interim Meeting be replaced with a revised version. Ms. Quinn noted that she had conducted a meeting on Sunday, July 19, 2015, with a group that included several meter manufacturers to consider the two proposals, and during this meeting, the group developed the revised version of the proposal. Based on Ms. Quinn's recommendations, the Committee agreed to replace the previous proposal with that shown in the "Item Under Consideration" above.

#### **Regional Association Comments:**

CWMA 2014 Interim Meeting: The CWMA heard a presentation to clarify the purpose of this item. A regulatory official voiced support for this item. The CWMA agreed that the item was sufficiently developed and recommended it be a Voting item as amended below:

**N.4.6. ~~Determination of Error on Vehicle Tank Meters with Multiple Flow Rates and Calibration Factors-Initial Verification. – On vehicle tank meters which are configured with multiple flow rates where each flow rate has its own calibration factor, and which are programmed to deliver a set quantity at a slow flow rate on start up and/or shut down, the effect of start up and shut down rates on the accuracy of the typical delivery shall be considered if the typical delivery is greater or less than the test measure used at the time of evaluation. The weights and measures jurisdiction shall determine the size of the typical delivery based upon available evidence. A vehicle tank meter shall be tested at all flow rates and with all products for which a calibration linearization factor has been electronically programmed prior to placing it into commercial service for the first time or after being repaired or replaced.~~**

**A vehicle tank meter not equipped with means to electronically program its flow rates and calibration linearization factors shall be tested at a low and high flow rate with all products delivered prior to placing it into commercial service for the first time or after being repaired or replaced.**

**Example: A vehicle tank meter is electronically programmed to deliver regular and premium gasoline at a startup/shutdown flow rate of 20 gpm, a normal operating flow rate of 100 gpm, and an intermediate rate of 65 gpm. The meter is to be tested with regular gasoline at 20 gpm, 65 gpm and 100 gpm; and with premium gasoline at 20 gpm, 65 gpm and 100 gpm.**

**The official with statutory authority has the discretion to determine the flow rates and products at which a vehicle tank meter will be tested on subsequent verifications.**



**UR.1.5. Initial Verification Proving Reports. – Initial verification proving reports for vehicle tank meters equipped with means to electronically program flow rates shall be attached to and sent with placed-in-service reports when the regulatory agency with statutory authority requires placed-in-service reports.**

CWMA 2015 Annual Meeting: The CWMA received comments from the submitter of the item indicating a WG was still developing the item. Consequently, the CWMA agreed to change its earlier recommendation that the item move forward as a Voting item to the recommendation of moving the item forward as a Developing item.

WWMA 2014 Annual Meeting: Testimony was presented at the 2014 WWMA Annual Meeting by a member of the MPCG, stating that the item is fully developed and ready to be a Voting item. No opposition was heard during the WWMA Open Hearings and the WWMA agreed that the item was sufficiently developed and recommended that it be a Voting item as amended below:

**N.4.6. Initial Verification.**

- (a) A vehicle tank meter shall be tested at all flow rates and with all products for which a calibration linearization factor has been electronically programmed prior to placing it into commercial service for the first time or after being repaired or replaced.**
- (b) A vehicle tank meter not equipped with means to electronically program its flow rates and calibration linearization factors shall be tested at a low and high flow rate with all products delivered prior to placing it into commercial service for the first time or after being repaired or replaced.**

**Example: A vehicle tank meter is electronically programmed to deliver regular and premium gasoline at a startup/shutdown flow rate of 20 gpm, a normal operating flow rate of 100 gpm, and an intermediate rate of 65 gpm. The meter is to be tested with regular gasoline at 20 gpm, 65 gpm and 100 gpm; and with premium gasoline at 20 gpm, 65 gpm and 100 gpm.**

**The official with statutory authority has the discretion to determine the flow rates and products at which a vehicle tank meter will be tested on subsequent verifications.**

**UR.1.5. Initial Verification Proving Reports. – Initial verification proving reports for vehicle tank meters equipped with means to electronically program flow rates shall be attached to and sent with placed-in-service reports when the regulatory agency with statutory authority requires placed-in-service reports.**

SWMA 2014 Annual Meeting: The SWMA's S&T Committee recommended the item be Withdrawn based on concerns that, if adopted, it would result in extensive additional work required by inspectors; increased downtime for businesses; questionable gain when compared to existing tolerances; and the approval of devices for each product type. The SWMA S&T Committee doesn't believe the handbooks are the proper place for examples. Based on the Committee's recommendation, the SWMA did not forward this item to the NCWM; recommending instead, that it be Withdrawn.

NEWMA 2014 Interim Meeting: NEWMA did not receive comments on this item at its 2014 Interim Meeting and recommended the item be Withdrawn. At its 2015 Annual Meeting, NEWMA did not receive comments, but changed its earlier position on this item, recommending it be Developing pending further information.

Additional letters, presentations, and data may have been part of the Committee's consideration. To review the supporting documentation, please refer to the *Report of the 99<sup>th</sup> National Conference on Weights and Measures* (SP1193, 2014).

### 332 LPG AND ANHYDROUS AMMONIA LIQUID-MEASURING DEVICES

332-1 I S.1.4.3. Provisions for Power Loss, S.1.5.1.1. Unit Price, S.1.5.1.2. Product Identity, S.1.6. For Retail Motor Vehicle Fuel Devices Only, S.1.7. For Wholesale Devices Only, UR.2.7. Unit Price and Product Identity, and UR.2.8. Computing Device.

**Source:**

California Department of Food and Agriculture Division of Measurement Standards (2014)

**Purpose:**

Add similar specifications and user requirements for other retail motor-fuel devices to NIST Handbook 44, Section 3.32. Liquefied Petroleum Gas (LPG) and Anhydrous Liquid-Measuring Devices Code similar to those in Section 3.30. Liquid-Measuring Devices, Section 3.37. Mass Flow Meters, and Section 3.39. Hydrogen-Gas Measuring Devices – Tentative Code.

**Item Under Consideration:**

Amend NIST Handbook 44, Liquefied Petroleum Gas and Anhydrous Liquid-Measuring Devices Code as follows:

**S.1.4. For Retail Devices Only (No Change)**

**S.1.4.1. Indication of Delivery (No Change)**

**S.1.4.2. Return to Zero (No Change)**

**S.1.4.3. Provisions for Power Loss.**

**S.1.4.3.1. Transaction Information.**

**(a) In the event of a power loss, a computing retail liquefied petroleum dispensing device shall display the information needed to complete any transaction in progress at the time of the power loss (such as the quantity and unit price, or sales price) shall be determinable for at least 15 minutes at the dispenser or at the console if the console is accessible to the customer.**

**(b) In the event of a power loss, both an electronic digital retail non-computing stationary liquefied petroleum gas dispenser and a vehicle-mounted electronic digital liquefied petroleum gas dispenser shall display the information needed to complete any transaction in progress at the time of the power loss.**

**S.1.4.3.2. User Information. – The device memory shall retain information on the quantity of fuel dispensed and the sales price totals during power loss.**

**S.1.5. For Stationary Retail Devices Only.**

**S.1.5.1. Display of Unit Price and Product Identity. – In a device of the computing type, means shall be provided for displaying on each face of the device the unit price at which the device is set to compute or to deliver as the case may be, and there shall be conspicuously displayed on each side of the device the identity of the product that is being dispensed. If a device is so designed as to dispense more than one grade, brand, blend, or mixture of product, the identity of the grade, brand, blend, or mixture being dispensed shall also be displayed on each face of the device.**

**S.1.5.1.1. Unit Price.**

**(a) A computing or money-operated device shall be able to display on each face the unit price at which the device is set to compute or to dispense.**

**(b) Except for dispensers used exclusively for fleet sales, other price contract sales, and truck refueling (e.g., truck stop dispensers used only to refuel trucks), whenever a grade, brand, blend, or mixture is offered for sale from a device at more than one-unit price, then all of the unit prices at which that product is offered for sale shall meet the following conditions:**

**(1) For a system that applies a discount prior to the delivery, all unit prices shall be displayed or shall be capable of being displayed on the dispenser through a deliberate action of the purchaser prior to the delivery of the product. It is not necessary that all of the unit prices for all grades, brands, blends, or mixtures be simultaneously displayed prior to the delivery of the product.**

**(2) For a system that offers post-delivery discounts on fuel sales, display of pre-delivery unit price information is exempt from (b)(1), provided the system complies with S.1.6.8. Recorded Representations for Transactions Where a Post-Delivery Discount(s) is Provided.**

**Note: When a product is offered at more than one-unit price, display of the unit price information may be through the deliberate action of the purchaser: 1) using controls on the device; 2) through the purchaser's use of personal or vehicle-mounted electronic equipment communicating with the system; or 3) verbal instructions by the customer.**

**S.1.5.1.2. Product Identity.**

**(a) A device shall be able to conspicuously display on each side the identity of the product being dispensed.**

**(b) A device designed to dispense more than one grade, brand, blend, or mixture of product also shall be able to display on each side the identity of the grade, brand, blend, or mixture being dispensed.**

**S.1.6. For Wholesale Devices Only For Retail Motor Vehicle Fuel Devices Only.**

**S.1.6.1. Zero-Set-Back Interlock, Retail Motor-Fuel Devices. – A device shall be constructed so that:**

**(a) after a delivery cycle has been completed by moving the starting lever to any position that shuts off the device, an automatic interlock prevents a subsequent delivery until the indicating elements, and recording elements if the device is equipped and activated to record, have been returned to their zero positions;**

**(b) the discharge nozzle cannot be returned to its designed hanging position (that is, any position where the tip of the nozzle is placed in its designed receptacle and the lock can be inserted) until the starting lever is in its designed shut-off position and the zero-set-back interlock has been engaged; and**

**(c) in a system with more than one dispenser supplied by a single pump, an effective automatic control valve in each dispenser prevents product from being delivered until the indicating elements on that dispenser are in a correct zero position.**

**S.1.6.2. Provisions for Power Loss.**

**S.1.6.2.1. Transaction Information.** – *In the event of a power loss, the information needed to complete any transaction in progress at the time of the power loss (such as the quantity and unit price, or sales price) shall be determinable for at least 15 minutes at the dispenser or at the console if the console is accessible to the customer.*

**S.1.6.2.2. User Information.** – *The device memory shall retain information on the quantity of fuel dispensed and the sales price totals during power loss.*

**S.1.6.3. Display of Unit Price and Product Identity.** *Except for fleet sales and other price contract sales, a motor vehicle fuel dispenser used to refuel vehicles shall be of the computing type and shall indicate the quantity, the unit price, and the total price of each delivery. The dispenser shall display the volume measured for each transaction.*

**S.1.6.4. Totalizers for Retail Motor-Fuel Dispensers.** – *Retail motor-fuel dispensers shall be equipped with a nonresettable totalizer for the quantity delivered through the metering device.*

**S.1.6.5. Money-Value Divisions.** – *A computing type shall comply with the requirements of paragraph G-S.5.5. Money-Values, Mathematical Agreement, and the total price computation shall be based on quantities not exceeding 0.05 L for devices indicating in metric units and 0.01 gal intervals for devices indicating in inch-pound units.*

**S.1.7. For Wholesale Devices Only.** (Renumbered - No Change)

**UR.2.7. Unit Price and Product Identity.**

**(a) The following information shall be conspicuously displayed or posted on the face of a retail dispenser used in direct sale:**

**(1) except for unit prices resulting from any post-delivery discount and dispensers used exclusively for fleet sales, other price contract sales, and truck refueling (e.g., truck stop dispensers used only to refuel trucks), all of the unit prices at which the product is offered for sale; and**

**(2) in the case of a computing type or money-operated type, the unit price at which the dispenser is set to compute.**

**Provided that the dispenser complies with S.1.5.1.1. Display of Unit Price, it is not necessary that all the unit prices for all grades, brands, blends, or mixtures be simultaneously displayed or posted.**

**(b) The following information shall be conspicuously displayed or posted on each side of a retail dispenser used in direct sale:**

**(1) the identity of the product in descriptive commercial terms; and**

**(2) the identity of the grade, brand, blend, or mixture that a multi-product dispenser is set to deliver.**

**UR.2.8. Computing Device.** – *Any computing device used in an application where a product or grade is offered for sale at one or more unit prices shall be used only for sales for which the device computes and displays the sales price for the selected transaction. The following exceptions apply:*

**(a) Fleet sales and other price contract sales are exempt from this requirement.**

**(b) A truck stop dispenser used exclusively for refueling trucks is exempt from this requirement provided that:**

- (1) all purchases of fuel are accompanied by a printed receipt of the transaction containing the applicable price per gallon, the total gallons delivered, and the total price of the sale; and**
- (2) unless a dispenser complies with S.1.6.4.1. Display of Unit Price, the price posted on the dispenser and the price at which the dispenser is set to compute shall be the highest price for any transaction which may be conducted.**

**(c) A dispenser used in an application where a price per unit discount is offered following the delivery is exempt from this requirement, provided the following conditions are satisfied:**

- (1) the unit price posted on the dispenser and the unit price at which the dispenser is set to compute shall be the highest unit price for any transaction;**
- (2) all purchases of fuel are accompanied by a printed receipt recorded by the system for the transaction containing:**
  - a. the product identity by name, symbol, abbreviation, or code number;**
  - b. transaction information as shown on the dispenser at the end of the delivery and prior to any post-delivery discount including the:**
    - 1. total volume of the delivery;**
    - 2. unit price; and**
    - 3. total computed price of the fuel sale prior to post-delivery discounts being applied.**
  - c. an itemization of the post-delivery discounts to the unit price; and**
  - d. the final total price of the fuel sale.**

**For systems equipped with the capability to issue an electronic receipt, the customer may be given the option to receive the receipt electronically (e.g., via cell phone, computer, etc.)**

**Background/Discussion:**

NCWM Publication 14, Checklist for Liquefied-Petroleum Gas (LPG) Retail Motor Fuel Devices verifies compliance with specifications, such as, “Power Loss” (which requires a 15 min power backup) and “Zero-Setback Interlocks.” However, these specifications are not located in Section 3.32. of NIST Handbook 44.

There are LPG devices with NTEP Certificates of Conformance (CC) that meet current “power loss” and “zero-setback interlock” requirements. However, there are other LPG retail motor-fuel devices in the field that consist of an assembly of separable, compatible, and type-evaluated LPG measuring and indicating elements, and key/card lock systems that do not meet the power loss and interlock requirements because those requirements are not within the LPG Code and those systems have not been submitted for type evaluation. This creates unfair competition with holders of type evaluation certificates for LPG retail dispensers.

There are newer LPG dispensers coming into use, where measuring, indicating, and computing elements are assembled in retail motor-fuel dispenser housings. These LPG devices serve as both propane bottle fillers and as retail motor-fuel devices using separate hoses and nozzles on a dispenser. While they do have a good safety history, many of these

dispensers are not assembled in compliance with safety standards such as UL 495 or 1238, or NFPA 50, nor, are they typically installed in accordance with NFPA 30A or NFPA 70.

Existing retail LPG dispensers can be adapted to fuel LPG-powered motor vehicles by adding a simple adaptor, which attaches to the LPG nozzle on the dispenser's hose. There are currently five active and two inactive NTEP CCs for LPG retail motor-fuel dispensers listed in the NCWM Database.

See the 2014 S&T Committee Annual Report for additional background information and to review previous language and positions to amend NIST Handbook 44, Liquefied Petroleum Gas and Anhydrous Liquid-Measuring Devices Code.

#### **2015 NCWM Interim Meeting:**

NCWM 2015 Interim Meeting: The Committee heard comments in support of changing the status of this item from Developing to Informational. Ms. Kristin Macey (California) reported that the expert assigned by California Division of Measurement Standards (DMS) to further develop this item is no longer employed with the state, and there is no one else within the California DMS that has the level of expertise required to complete this assignment. She suggested OWM complete any final changes that might be needed.

Mr. Dmitri Karimov (Liquid Controls, LLC) voiced concern regarding proposed paragraph S.1.4.3. Provisions for Power Loss. He noted this paragraph, if adopted, would apply to both stationary and vehicle-mounted meters. Vehicle mounted meters receive power from a vehicle's battery. He indicated that he believes the power loss provision paragraph needs more consideration and also noted there is no such requirement in the Vehicle-Tank Meters Code of NIST Handbook 44.

Ms. Tina Butcher (NIST, OWM) commented that NIST, OWM believes this proposal includes much-needed changes that will help to align requirements for LPG retail motor-fuel systems with those for retail motor-fuel systems covered under other NIST Handbook 44 measuring codes. She noted that the California Division of Measurement Standards and the WWMA have done excellent work in developing this item and, with some additional changes, NIST, OWM believes the item is ready for NCWM consideration as a Voting item.

NIST, OWM recommended that the Item Under Consideration as shown in NCWM Publication 15 be replaced with the revised version presented by the WWMA, with the following additional changes from NIST, OWM. A revised version of the proposal (including the NIST, OWM proposed changes to the WWMA version) appears at the end of this summary.

*[Technical Advisor's Note: As requested by the S&T Committee, following the 2015 Interim Meeting, NIST Technical Advisors consulted with Mr. Karimov, representing the MMA, to discuss MMA's concerns over proposed power loss requirements. During this discussion, NIST OWM acknowledged that confusion exists about the application of requirements to retail fueling systems that are not enclosed in a "cabinet" or "dispenser" housing yet include the same major components as conventional "dispensers" and are used in the same application and noted that the current proposal is intended to clarify these requirements. NIST, OWM also noted that references to retail fueling systems are not consistent throughout this and other measuring device codes and the inconsistent use of terminology in NIST Handbook 44 may also be contributing to this confusion. NIST, OWM has begun reviewing existing terminology and may propose additional changes (as part of this item or as an additional, new item) to ensure consistency in references in this and other measuring codes to terms such as the following: "retail motor-fuel dispenser," "retail motor-fuel device," "retail motor-fuel system," "retail motor-fuel dispensing system," and "retail vehicle fuel device." NIST, OWM has since identified a few additional changes that it will propose and submit to the Committee to include with this item prior to the NCWM Annual Meeting.]*

#### **S.1.3.6. Transaction Information. – Move to S.1.5. Stationary Retail Devices:**

Consideration should be given to moving this paragraph (which addresses power loss requirements) to Section "S.1.5. For Stationary Retail Devices Only." While it makes sense for the paragraph to fall under requirements for "indicators," comments from industry have questioned its applicability to vehicle-mounted, retail meters. Industry has pointed out that other vehicle-mounted applications, as addressed in the Vehicle-Tank Meters Code, do not include

such provisions for retail deliveries. Thus, restricting its application to stationary retail devices in the LPG and NH<sub>3</sub> Code would eliminate this concern.

Additionally, OWM suggests that the title of this paragraph be revised to include a reference to “power loss” for easier reference.

**S.1.4. For Retail Devices Only.**

**S.1.4.1. Indication of Delivery.**

Modify S.1.4.1. as shown in NIST, OWM’s original, 2014 comments so it mirrors the corresponding paragraph (S.1.6.1. Indication of Delivery) in the LMD Code, both in language and in the requirement for electronic devices to inhibit indications until fueling conditions ensure that the delivery starts on zero.

**S.1.4.3. Zero-Set-Back Interlock for Retail Motor-Fuel Dispensers:**

Delete the reference to “retail motor-fuel” in the first sentence.

**S.1.5. For Stationary Retail Devices Only:**

**S.1.5.1. Display of Unit Price and Product Identity:**

Delete the proposed sub-paragraph (a). This language is redundant with the lead paragraph. Delete the letter “(b)” designation on the subsequent subparagraph and insert “and” after “fleet sales” in that same sub-paragraph. Delete the reference to “(b)” in subparagraph (2).

Change the reference to “purchaser” to “customer” in the “Note.” to be consistent with other references in this paragraph.

**S.1.5. For Stationary Retail Devices Only:**

OWM believes that existing paragraph “S.1.5.3. Recorded Representations, Point-of-Sale Systems” should be struck; proposed new S.1.5.5. Recorded Representations” and “S.1.5.6. Recorded Representations Where a Post-Delivery Discount(s) is Provided” would eliminate the need for the existing S.1.5.3. paragraph. Remaining paragraphs should be renumbered accordingly.

OWM believes that there is no need for the proposed “S.1.5.5. Recorded Representations” to be a given a “nonretroactive” status. The current paragraph “S.1.5.3. Recorded Representations, Point-of-Sale Systems” currently applies the *same* requirements to the *same* devices covered in the new paragraph S.1.5.5. on a “retroactive” basis. Likewise, the proposed paragraph S.1.5. mirrors a paragraph in the LMD Code which was added as a retroactive paragraph in the LMD Code in 2012.

**S.1.5.3. Agreement Between Indications (Proposed by WWMA as S.1.5.4.):**

Renumber to S.1.5.3. from S.1.5.4. in WWMA’s latest proposal. Suggest adding a proposal to modify LMD Code paragraph S.1.6.6.(b) to mirror the proposed language in part (b) of this proposal.

**S.1.5.4. Recorded Representations (Proposed by WWMA as S.1.5.5):**

Renumber to S.1.5.4. from S.1.5.5. in WWMA’s latest proposal.

**S.1.5.5. Recorded Representations for Transactions Where a Post-Delivery Discount(s) is Provided:**

Renumber to S.1.5.5. from S.1.5.6. in WWMA’s latest proposal.

Add “printed” prior to “receipt” in the first sentence to be consistent with the corresponding provision in the LMD Code.

**S.1.5.6. Transaction Information, Power Loss. (new):**

Move the paragraph S.1.3.6. proposed by the WWMA to become S.1.5.6. and modify the title as described above under S.1.3.6.

**UR.2.7.2. (b)(2) Computing Device:**

Correct reference to S.1.6.4.1. (a reference to an LMD Code paragraph) to be S.1.5.1.

Incorporating the changes proposed by OWM as outlined above in the WWMA proposal, the revised version would appear as follows:

**S.1.4. For Retail Devices Only.**

**S.1.4.1. Indication of Delivery.** – A retail device shall ~~be constructed to show~~ automatically **show** on its ~~face the~~ initial zero condition and the ~~amounts~~ **quantity** delivered up to the nominal capacity of the device. However, the following requirements shall apply:

For electronic devices manufactured prior to January 1, 2006, the first 0.03 L (or 0.009 gal) of a delivery and its associated total sales price need not be indicated.

For electronic devices manufactured on or after January 1, 2006, the measurement, indication of delivered quantity, and the indication of total sales price shall be inhibited until the fueling position reaches conditions necessary to ensure that the delivery starts at zero.

[Nonretroactive as of January 1, 20XX]

(Amended 20XX)

...

S.1.4.3. Zero-Set-Back Interlock for Retail Motor-Fuel Devices. – A device shall be constructed so that:

(a) after a delivery cycle has been completed by moving the starting lever to any position that shuts off the device, an automatic interlock prevents a subsequent delivery until the indicating elements, and recording elements if the device is equipped and activated to record, have been returned to their zero positions;

(b) the discharge nozzle cannot be returned to its designed hanging position (that is, any position where the tip of the nozzle is placed in its designed receptacle and the lock can be inserted) until the starting lever is in its designed shut-off position and the zero-set-back interlock has been engaged; and

(c) in a system with more than one dispenser supplied by a single pump, an effective automatic control valve in each dispenser prevents product from being delivered until the indicating elements on that dispenser are in a correct zero position.

[Nonretroactive as of January 1, 20XX]

(Added 20XX)

**S.1.5. For Stationary Retail Devices Only.**

**S.1.5.1. Display of Unit Price and Product Identity.** – ~~In a~~ **A** device of the computing type, ~~means~~ shall be ~~provided for~~ **able to** displaying on each face ~~of the device~~ the unit price at which the device is



set to compute or to deliver ~~as the case may be~~, and there shall be conspicuously displayed on each side of the device the identity of the product that is being dispensed. ~~If a device is so designed as to dispense more than one grade, brand, blend, or mixture of product, the identity of the grade, brand, blend, or mixture being dispensed shall also be displayed on each face of the device.~~

Except for dispensers used exclusively for fleet sales and other price contract sales, all of the unit prices at which that product is offered for sale shall meet the following conditions:

- (1) For a system that applies a discount prior to the delivery, all unit prices shall be displayed or shall be capable of being displayed on the dispenser through a deliberate action of the purchaser prior to the delivery of the product. It is not necessary that all of the unit prices be simultaneously displayed prior to the delivery of the product.
- (2) For a system that offers post-delivery discounts on fuel sales, display of pre-delivery unit price information is exempt from (1) above, provided the system complies with S.1.5.5. Recorded Representations for Transactions Where a Post-Delivery Discount(s) is Provided.

Note: When a product is offered at more than one-unit price, display of the unit price information may be through the deliberate action of the customer: 1) using controls on the device; 2) through the customer's use of personal or vehicle-mounted electronic equipment communicating with the system; or 3) verbal instructions by the customer.

[Nonretroactive as of January 1, 20XX]

(Added 20XX)

~~S.1.5.3. — Recorded Representations, Point of Sale Systems. — Except for fleet sales and other price contract sales, a printed receipt providing the following information shall be available through a built in or separate recording element for all transactions conducted with point of sale systems or devices activated by debit cards, credit cards, and/or cash:~~

- ~~(a) the total volume of the delivery;~~
- ~~(b) the unit price;~~
- ~~(c) the total computed price; and~~
- ~~(d) the product identity by name, symbol, abbreviation, or code number.~~

~~(Added 2014)~~

**S.1.5.3. Agreement Between Indications.**

**(a) When a quantity value indicated or recorded by an auxiliary element is a derived or computed value based on data received from a device, the value may differ from the quantity value displayed on the dispenser, provided that the following conditions are met:**

- (1) all total values for an individual sale that are indicated or recorded by the system agree; and**
- (2) Within each element, the values indicated or recorded meet the formula (quantity x unit price = total sales price) to the closest cent.**

**(b) When a system applies a post-delivery discount(s) to a fuel's unit price through an auxiliary element, the total volume of the delivery shall be in agreement between all elements in the system.**

**[Nonretroactive as of January 1, 20XX]**

**(Added 20XX)**

**S.1.5.4. Recorded Representations. – Except for fleet sales and other price contract sales and for transactions where a post-delivery discount is provided, a receipt providing the following information shall be available through a built-in or separate recording element for all transactions conducted with point-of-sale systems or devices activated by debit cards, credit cards, and/or cash:**

- (a) the total volume of the delivery;**
- (b) the unit price;**
- (c) the total computed price; and**
- (d) the product identity by name, symbol, abbreviation, or code number.**

**(Added 20XX)**

**S.1.5.5. Recorded Representations for Transactions Where a Post-Delivery Discount(s) is Provided. – Except for fleet sales and other price contract sales, a printed receipt providing the following information shall be available through a built-in or separate recording element that is part of the system for transactions involving a post-delivery discount:**

- (a) the product identity by name, symbol, abbreviation, or code number;**
- (b) transaction information as shown on the dispenser at the end of the delivery and prior to any post-delivery discount(s), including the:**
  - (1) total volume of the delivery;**
  - (2) unit price; and**
  - (3) total computed price of the fuel sale.**
- (c) an itemization of the post-delivery discounts to the unit price; and**
- (d) the final total price of the fuel sale after all post-delivery discounts are applied.**

**(Added 20XX)**

**S.1.5.6. Transaction Information, Power Loss. In the event of a power loss, the information needed to complete any transaction in progress at the time of the power loss (such as the quantity and unit price, or sales price) shall be determinable for at least 15 minutes at the device or other onsite device accessible to the customer.**

[Nonretroactive as of January 1, 20XX]

(Added 20XX)

S.1.5.7. Totalizers for Retail Motor-Fuel Dispensers. – Retail motor-fuel dispensers shall be equipped with a nonresettable totalizer for the quantity delivered through the metering device.

[Nonretroactive as of January 1, 20XX]

(Added 20XX)

UR.2. Use Requirements.

UR.2.7. For Stationary Retail Computing Type Systems Only, Installed After January 1, 20XX.

UR.2.7.1. Unit Price and Product Identity.

(a) The following information shall be conspicuously displayed or posted on the face of a retail dispenser used in direct sale:

(1) except for unit prices resulting from any post-delivery discount and dispensers used exclusively for fleet sales, other price contract sales, and truck refueling (e.g., truck stop dispensers used only to refuel trucks), all of the unit prices at which the product is offered for sale; and

(2) in the case of a computing type device or money-operated type device, the unit price at which the dispenser is set to compute.

Provided that the dispenser complies with S.1.5.1. Display of Unit Price and Product Identity, it is not necessary that all the unit prices be simultaneously displayed or posted.

(b) The following information shall be conspicuously displayed or posted on each side of a retail dispenser used in direct sale:

(1) the identity of the product in descriptive commercial terms; and

(2) the identity of the grade, brand, blend, or mixture that a multi-product dispenser is set to deliver.

(Added 20XX)

UR.2.7.2. Computing Device. – Any computing device used in an application where a product or grade is offered for sale at one or more unit prices shall be used only for sales for which the device computes and displays the sales price for the selected transaction.

The following exceptions apply:

(a) Fleet sales and other price contract sales are exempt from this requirement.

(b) A truck stop dispenser used exclusively for refueling trucks is exempt from this requirement provided that:

(1) all purchases of fuel are accompanied by a printed receipt of the transaction containing the applicable price per unit of measure, the total quantity delivered, and the total price of the sale; and

(2) unless a dispenser complies with S.1.5.1. Display of Unit Price, the price posted on the dispenser and the price at which the dispenser is set to compute shall be the highest price for any transaction which may be conducted.

(c) A dispenser used in an application where a price per unit discount is offered following the delivery is exempt from this requirement, provided the following conditions are satisfied:

(1) the unit price posted on the dispenser and the unit price at which the dispenser is set to compute shall be the highest unit price for any transaction;

(2) all purchases of fuel are accompanied by a receipt recorded by the system for the transaction containing:

a. the product identity by name, symbol, abbreviation, or code number;

b. transaction information as shown on the dispenser at the end of the delivery and prior to any post-delivery discount including the:

1. total volume of the delivery;

2. unit price; and

3. total computed price of the fuel sale prior to post-delivery discounts being applied.

c. an itemization of the post-delivery discounts to the unit price; and

d. the final total price of the fuel sale after all post-delivery discounts are applied.

**(Added 20XX)**

Based on comments heard during the Open Hearings indicating the proposal is nearly ready for adoption, the Committee agreed to elevate the status of this item to an Informational item as requested by the State of California. In doing so, the Committee also requested Mr. Karimov work with NIST, OWM to further refine the language to address any remaining concerns.

### **2015 NCWM Annual Meeting**

NCWM 2015 Annual Meeting: The Committee heard many comments in support of this item and none opposed. Ms. Tina Butcher (NIST, OWM) recommended the item move forward as revised at the 2014 WWMA with the proposed amendments of OWM and with continued input from the meter manufacturers. She commented that this item is very close to being ready for submittal as a Voting item.

Dmitri Karimov (IDEX Corporation), speaking on behalf IDEX Corporation and the MMA testified that the zero-set-back interlock requirement should be limited to stationary retail devices only. He also commented that he is working with NIST, OWM in refining this proposal, and it is very near moving forward as a Voting item.

One state weights and measures representative questioned the use of the words “shall be able to display” in the changes proposed to paragraph S.1.5.1. Display of Unit Price and Product Identity and why the words “shall display” were not proposed instead. Ms. Butcher answered the question noting that the words “shall be able to display” is referencing unit price, which can be changed. That is, the device must be capable of displaying whatever the current unit price is for the product being offered for sale. Mr. Dick Suiter (Richard Suiter Consulting), agreeing with Ms. Butcher, expanded upon her explanation by stating it is appropriate for “specification” requirements in NIST Handbook 44 to include terms such as “capable of” rather than be written as “hard” requirements.

The Committee agreed to maintain the Informational status of this item, noting that additional work was still needed to further develop the item. The Committee noted that it looks forward to future refinements of the item.

**Regional Association Meetings:**

CWMA 2014 Interim Meeting: The CWMA received comments supporting the need for this item. The CWMA believes this item is sufficiently developed and recommended that the item be a Voting item. At the 2015 CWMA Annual Meeting, there were no comments heard on this item and the CWMA recommended it move forward as an Informational item.

WWMA 2014 Annual Meeting Open Hearings: The submitter of the item provided an update and stated that several changes have been made to address NIST OWM concerns. Several regulators commented that this may impact owners of devices that are currently in use and urged caution. The submitter provided several updates to the WWMA S&T Committee to address comments heard during Open Hearings. These changes were included on the addendum sheet prior to the voting session. The WWMA recommended this as an Information item to allow for additional review, comment and future consideration; including whether or not the retroactive dates should mirror the effective dates of similar paragraphs in the LMD code.

**S.1.3. Indicators.**

*S.1.3.6. Transaction Information. – In the event of a power loss, the information needed to complete any transaction in progress at the time of the power loss (such as the quantity and unit price, or sales price) shall be determinable for at least 15 minutes at the device or other onsite device accessible to the customer. [Nonretroactive as of January 1, 20XX]*  
*(Added 20XX)*

**S.1.4. For Retail Devices Only.**

*S.1.4.3. Zero-Set-Back Interlock for Retail Motor-Fuel Devices – A retail motor-fuel device shall be constructed so that:*

- (a) after a delivery cycle has been completed by moving the starting lever to any position that shuts off the device, an automatic interlock prevents a subsequent delivery until the indicating elements, and recording elements if the device is equipped and activated to record, have been returned to their zero positions;*
- (b) the discharge nozzle cannot be returned to its designed hanging position (that is, any position where the tip of the nozzle is placed in its designed receptacle and the lock can be inserted) until the starting lever is in its designed shut-off position and the zero-set-back interlock has been engaged; and*
- (c) in a system with more than one dispenser supplied by a single pump, an effective automatic control valve in each dispenser prevents product from being delivered until the indicating elements on that dispenser are in a correct zero position. [Nonretroactive as of January 1, 20XX]*  
*(Added 20XX)*

**S.1.5. For Stationary Retail Devices Only.**

**S.1.5.1. Display of Unit Price and Product Identity.** – In a device of the computing type, means shall be provided for displaying on each face of the device the unit price at which the device is set to compute or to deliver as the case may be, and there shall be conspicuously displayed on each side of the device the identity of the product that is being dispensed. ~~If a device is so designed as to dispense more than one grade, brand, blend, or mixture of product, the identity of the grade, brand, blend, or mixture being dispensed shall also be displayed on each face of the device.~~

(a) A computing or money-operated device shall be able to display on each face the unit price at which the device is set to compute or to dispense.

(b) Except for dispensers used exclusively for fleet sales, other price contract sales, all of the unit prices at which that product is offered for sale shall meet the following conditions:

(1) For a system that applies a discount prior to the delivery, all unit prices shall be displayed or shall be capable of being displayed on the dispenser through a deliberate action of the purchaser prior to the delivery of the product. It is not necessary that all of the unit prices be simultaneously displayed prior to the delivery of the product.

(2) For a system that offers post-delivery discounts on fuel sales, display of predelivery unit price information is exempt from (b)(1), provided the system complies with S.1.5.7. Recorded Representations for Transactions Where a Post-Delivery Discount(s) is Provided.

Note: When a product is offered at more than one unit price, display of the unit price information may be through the deliberate action of the purchaser: 1) using controls on the device; 2) through the purchaser's use of personal or vehicle-mounted electronic equipment communicating with the system; or 3) verbal instructions by the customer.

[Nonretroactive as of January 1, 20XX]

(Added 20XX)

#### S.1.5.4. Agreement Between Indications.

(a) When a quantity value indicated or recorded by an auxiliary element is a derived or computed value based on data received from a device, the value may differ from the quantity value displayed on the dispenser, provided that the following conditions are met:

(1) all total values for an individual sale that are indicated or recorded by the system agree; and

(2) Within each element, the values indicated or recorded meet the formula (quantity × unit price = total sales price) to the closest cent.

(b) When a system applies a post-delivery discount(s) to a fuel's unit price through an auxiliary element, the total volume of the delivery shall be in agreement between all elements in the system.

[Nonretroactive as of January 1, 20XX]

(Added 20XX)

S.1.5.5. Recorded Representations. – Except for fleet sales and other price contract sales and for transactions where a post-delivery discount is provided, a receipt providing the following information shall be available through a built-in or separate recording element for all transactions conducted with point-of-sale systems or devices activated by debit cards, credit cards, and/or cash:

(a) the total volume of the delivery;

(b) the unit price;

(c) the total computed price; and

(d) the product identity by name, symbol, abbreviation, or code number.

[Nonretroactive as of January 1, 20XX]

(Added 20XX)

**S.1.5.6. Recorded Representations for Transactions Where a Post-Delivery Discount(s) is Provided. – Except for fleet sales and other price contract sales, a receipt providing the following information shall be available through a built-in or separate recording element that is part of the system for transactions involving a post-delivery discount:**

- (a) the product identity by name, symbol, abbreviation, or code number;**
- (b) transaction information as shown on the dispenser at the end of the delivery and prior to any post-delivery discount(s), including the:**
  - (1) total volume of the delivery;**
  - (2) unit price; and**
  - (3) total computed price of the fuel sale.**
- (c) an itemization of the post-delivery discounts to the unit price; and**
- (d) the final total price of the fuel sale after all post-delivery discounts are applied.**

**[Nonretroactive as of January 1, 20XX]**

**(Added 20XX)**

**S.1.5.7. Totalizers for Retail Motor-Fuel Dispensers. – Retail motor-fuel dispensers shall be equipped with a nonresettable totalizer for the quantity delivered through the metering device.**

**[Nonretroactive as of January 1, 20XX]**

**(Added 20XX)**

**UR.2. Use Requirements.**

**UR.2.7. For Stationary Retail Computing Type Devices Only Installed After January 1, 20XX.**

**UR.2.7.1. Unit Price and Product Identity.**

- (a) The following information shall be conspicuously displayed or posted on the face of a retail dispenser used in direct sale:**
  - (1) except for unit prices resulting from any post-delivery discount and dispensers used exclusively for fleet sales, other price contract sales, and truck refueling (e.g., truck stop dispensers used only to refuel trucks), all of the unit prices at which the product is offered for sale; and**
  - (2) in the case of a computing type device or money-operated type device, the unit price at which the dispenser is set to compute.**

**Provided that the dispenser complies with S.1.5.1. Display of Unit Price and Product Identity, it is not necessary that all the unit prices be simultaneously displayed or posted.**

- (b) The following information shall be conspicuously displayed or posted on each side of a retail dispenser used in direct sale:**
  - (1) the identity of the product in descriptive commercial terms; and**

- (2) the identity of the grade, brand, blend, or mixture that a multi-product dispenser is set to deliver.**

**(Added 20XX)**

**UR.2.7.2. Computing Device. – Any computing device used in an application where a product or grade is offered for sale at one or more unit prices shall be used only for sales for which the device computes and displays the sales price for the selected transaction. The following exceptions apply:**

- (a) Fleet sales and other price contract sales are exempt from this requirement.**
- (b) A truck stop dispenser used exclusively for refueling trucks is exempt from this requirement provided that:**
- (1) all purchases of fuel are accompanied by a printed receipt of the transaction containing the applicable price per unit of measure, the total quantity delivered, and the total price of the sale; and**
- (2) unless a dispenser complies with S.1.6.4.1. Display of Unit Price, the price posted on the dispenser and the price at which the dispenser is set to compute shall be the highest price for any transaction which may be conducted.**
- (c) A dispenser used in an application where a price per unit discount is offered following the delivery is exempt from this requirement, provided the following conditions are satisfied:**
- (1) the unit price posted on the dispenser and the unit price at which the dispenser is set to compute shall be the highest unit price for any transaction;**
- (2) all purchases of fuel are accompanied by a receipt recorded by the system for the transaction containing:**
- a. the product identity by name, symbol, abbreviation, or code number;**
- b. transaction information as shown on the dispenser at the end of the delivery and prior to any post-delivery discount including the:**
- 1. total volume of the delivery;**
- 2. unit price; and**
- 3. total computed price of the fuel sale prior to post-delivery discounts being applied.**
- c. an itemization of the post-delivery discounts to the unit price; and**
- d. the final total price of the fuel sale after all post-delivery discounts are applied.**

**(Added 20XX)**

SWMA 2014 Annual Meeting: The SWMA was informed there was new language from the submitter and encouraged the NCWM S&T Committee to review this language. The SWMA recommended that this item be a Developing item.

NEWMA 2014 Interim Meeting: NEWMA did not receive comments on the item and recommended that it remain a Developing item due to concerns from NIST, OWM regarding some of the language in the proposal. At its 2015 Annual Meeting, NEWMA recommended this item remain an Informational item as work continues on Developing the proposal.



Additional letters, presentations, and data may have been part of the Committee's consideration. To review the supporting documentation, please refer to the *Report of the 99<sup>th</sup> National Conference on Weights and Measures* (SP1193, 2014).

### 332-2 D N.3. Test Drafts.

**Source:**

Endress + Hauser Flowtec AG USA (2015)

**Purpose:**

Allow transfer standard meters to be used to test and place into service dispensers and delivery system flow meters.

**Item Under Consideration:**

Amend NIST Handbook 44, LPG and Anhydrous Ammonia Liquid-Measuring Devices as follows:

#### N.3. Test Drafts.

**N.3.1. Minimum Test.** – Test drafts should be equal to at least the amount delivered by the device in one minute at its normal discharge rate.

(Amended 1982)

**N.3.2. Transfer Standard Test. – When comparing a meter with a calibrated transfer standard, the test draft shall be equal to at least the amount delivered by the device in two minutes at its maximum discharge rate.**

**Background/Discussion:**

The use of transfer standards is recognized in the following NIST Handbook 44, Sections 3.34. Cryogenic Liquid-Measuring Devices Code; 3.38. Carbon Dioxide Liquid-Measuring Devices Code; and 3.39. Hydrogen Gas-Measuring Devices – Tentative Code. Field evaluation of LPG meters and CNG dispensers and LNG dispensers is very difficult using volumetric and gravimetric field standards and methods. The tolerances for these applications are such that using transfer meter standards are more efficient and safer. With CNG, LNG, and LPG applications, transfer standard meters are placed in-line with the delivery system as it is used to fill tanks and vehicles. The use of transfer standards eliminates return to storage issues. The use of transfer standard meters is easier and faster compared to the use of traditional field standards. The cost of using transfer standards and transporting them is much less than the cost of traditional field provers and standards. The submitter believes recognition in NIST Handbook 44 will enable states to allow transfer standard meters to place systems into service and for field enforcement.

Volumetric field provers and gravimetric field proving are susceptible to environmental influences. The State of Colorado uses a master meter to test propane delivery truck meters. The State of Nebraska has used a mass flow meter to test agricultural chemical meters.

In some applications, transfer standard meters are not more accurate than the meters used in the dispenser. For that reason, longer test drafts and possibly more tests need to be run.

The State of California is purported to have conducted a short study of master meters in the past. The conclusion did not lead to wide adoption of the practice. However, the State of California uses a mass flow meter as a master meter for carbon dioxide flowmeter enforcement.

Mass Flow Meters Code paragraph U.R.3.8. Return of Product to Storage, Retail Compressed Natural Gas Dispensers requires that the natural gas, which is delivered into the test container, must be returned to storage. This is difficult and most often not complied with when the test vessel contents are released to atmosphere. *[Technical Advisor's Note: Paragraph UR.3.8. also provides the option to the device owner or operator to otherwise safely dispose of the product. See paragraph UR.3.8. for details.]*

The Committee might also consider amending Sections 3.30. Liquid-Measuring Devices Code and 3.31. Vehicle-Tank Meters Code to allow the use of transfer standard meters.

**2015 NCWM Interim Meeting:**

NCWM 2015 Interim Meeting: The Committee agreed to group together Agenda Items 330-2 and 337-3 since these items are related and announced that comments on both items would be taken together during the Open Hearings.

Mr. Michael Keilty (Endress + Hauser Flowtec AG USA), submitter of the item, presented a short list of benefits to using a master meter as the standard in testing meters used in applications to measure CNG, LNG, and LPG in comparison to using volumetric or gravimetric standards. He stated that master meters are safer, more efficient, and provide a faster means of verifying meter accuracy. An additional benefit is that using a master meter eliminates the need to return product to storage because product can be dispensed through the master meter as part of the refueling procedure. He encouraged the recognition of master meters in NIST Handbook 44 for use as a transfer standard in testing.

Mr. Henry Oppermann (Weights and Measures Consulting, LLC) provided written comments to the Committee concerning this item, which he summarized in comments presented during the Open Hearings. Mr. Oppermann stated there are significant differences between a transfer standard and a field standard. It is necessary to consider the accuracy of these standards. Field standards must satisfy the Fundamental Considerations of NIST Handbook 44 Section 3.2. Tolerances for Standards, whereas transfer standards are recognized for use in some handbook device codes, but do not satisfy the one-third requirement specified in Section 3.2. (*Technical Advisors note: Section 3.2. of the Fundamental Considerations requires the combined error and uncertainty of any standard used in testing to be less than one-third the applicable tolerance applied to the device under test unless corrections are made*). Mr. Oppermann recommended keeping clear this distinction; noting the current proposal is incomplete if it doesn't include an additional tolerance when you test a device using a master meter (i.e., a transfer standard).

In response to Mr. Oppermann's comment regarding the need for an additional tolerance, Mr. Keilty stated that he isn't requesting a different tolerance be applied to the device under test. Current technology already enables the standard to comply.

Ms. Tina Butcher (NIST, OWM) acknowledged that development of alternative methods of testing is beneficial because there are many applications where the nature of the product makes current methods impractical. She stressed, however, that adding a paragraph to NIST Handbook 44, alone, doesn't provide recognition of a test method. There is a laundry list of pieces that need to be in place before a standard should be considered suitable for use in testing by providing traceable measurements including things such as:

- the accuracy of the standard (or the degree of accuracy that one can expect to achieve from using the standard) in relation to the tolerances that apply to the device being tested;
- NIST Handbook 44, Fundamental Considerations – Tolerances for Standards;
- proper training and procedures for using the standard;
- training of laboratory personnel and the capability of the labs to verify the adequacy of the standard for use in testing another device; and
- collection and analysis of data obtained from having used the standard repeatedly over time.

Ms. Butcher also noted that a USNWG has been assembled to review the different (alternative) test methods and this might be an appropriate group to review such equipment as resources allow. She also noted that the decision of whether or not to accept a particular method ultimately rests with the regulatory authority.

Mr. Dmitri Karimov (Liquid Control, LLC) noted that the Mass Flow Meters Code covers all applications where a mass flow meter is used. There are five measuring device codes within NIST Handbook 44. Simply adding language to recognize the use of a particular piece of test equipment doesn't necessarily ensure its use is acceptable in testing.

The decision of whether or not to use the test equipment resides with the regulatory authority where the meters are located.

The Committee agreed this item has merit and recommends the submitter of these items work with NIST, OWM by providing data for the WG to consider in determining the suitability of the master meter transfer standard as a standard in testing another device.

**2015 NCWM Annual Meeting:**

NCWM 2015 Annual Meeting: The Committee agreed to group together Agenda Items 332-2 and 337-3 and took comments on the two items simultaneously. The Committee heard comments both in support of and opposition to the proposals.

Mr. Michael Keilty (Endress + Hauser Flowtec AG USA), submitter of the item noted there is already an allowance for a field transfer standard in the Cryogenic Liquid-Measuring Devices Code, Carbon Dioxide Liquid-Measuring Devices Code, and in the Hydrogen Gas-Measuring Devices – Tentative Code. He asked there also be an allowance for a field transfer standard in the LPG and Anhydrous Ammonia Liquid-Measuring Devices Code and the Mass Flow Meters Code, noting there's already information in those codes to support using a transfer standard. He also requested the Committee consider moving these two items forward as Voting items.

Mr. Henry Oppermann (Weights and Measures Consulting, LLC) speaking on behalf of Seraphin Test Measure, Co. commented that there's a difference between a transfer standard and a field standard. Field standards must comply with the NIST Handbook 105 series. A transfer standard, in order to be used for testing another device, must be accurate and repeatable over the full range of how it will be used, to include temperature, flow rates, etc. Accuracy and repeatability must not change between times when it is used. He stated that Mr. Keilty is looking at a standard to meet the Fundamental Considerations of NIST Handbook 44; it is his (Mr. Oppermann's) view that it's a field standard and not a transfer standard.

Ms. Butcher commented stated NIST, OWM believes the development of alternative methods of testing commercial metering systems is an important issue. There are many applications in which using currently recognized test methods may not be feasible because of product characteristics, safety, cost, access to equipment, and other factors. NIST, OWM is not opposed to adding a paragraph to the two device codes as proposed, but by doing so, it wouldn't ensure approval of any proposed test method. The decision on whether or not to accept a particular test method for use in testing commercial weighing and measuring equipment ultimately rests with the regulatory authority.

There are a number of things that must be considered when selecting field standards and determining whether or not they are suitable and can be used to provide traceable measurements. These factors are sometimes referred to as the "essential elements of traceability." As noted by NIST, OWM during the 2015 NCWM Interim Meeting, the pieces need to be in place before a standard should be considered suitable for use in testing by providing traceable measurements include things such as:

- the accuracy of the standard (or the degree of accuracy that one can expect to achieve from using the standard) in relation to the tolerances that apply to the device being tested;
- NIST Handbook 44, Fundamental Considerations – Tolerances for Standards;
- proper training and procedures for using the standard;
- training of laboratory personnel and the capability of the labs to verify the adequacy of the standard for use in testing another device; and
- collection and analysis of data obtained from having used the standard repeatedly over time.

With regard to the relative accuracy of a particular test standard, the Fundamental Considerations in NIST Handbook 44, Section 3.2. Tolerances for Standards specify that when a standard is used without correction its combined error and uncertainty must be less than one third of the applicable tolerance. Some of the other factors

include demonstrated reliability of the device over time; device repeatability; how well it duplicates actual use; existence of documentary standards for the test equipment; availability of equipment and facilities within a state laboratory to test the equipment; and whether training has been provided for the laboratory staff, field officials, and users of the equipment. These and other factors have also been raised by others during the Committee's Open Hearings.

NIST OWM established a USNWG to examine alternative test methods. A subgroup within that USNWG is presently working to establish uncertainties for selected different test methods. NIST, OWM has circulated a draft document with guidelines for collecting test data within this subgroup; once finalized, this document might be useful in collecting such data on the use of other types of standards. Currently, there are no representatives on the Subcommittee to review factors that affect the uncertainties of measurements using master meters. However, several members of the larger WG have expressed interest in developing standards and test procedures for master meters in some applications. Should industry want to pursue recognition of master meters, test data may be needed to determine whether or not this is a viable method, and the OWM guidelines might be used for this purpose. Collecting data to assess the test uncertainties associated with using master meters would provide useful information on the potential use of transfer standard meters (master meters) for field testing.

With regard to the specific language in the proposed new paragraph N.3.2. Transfer Standard Test, the Developer may wish to consider eliminating the phrase "test draft" and replacing it with the phrase "delivered quantity" as shown in the alternative version below. This change would be consistent with changes made in 1996 to LMD Code requirements for test drafts to better allow for the use of alternative test methods such as small volume provers.

**N.3.2. Transfer Standard Test. – When comparing a meter with a calibrated transfer standard, the delivered quantity shall be equal to at least the amount delivered by the device in two minutes at its maximum discharge rate.**

Ms. Kristin Macey (California) commented that if the proposal were adopted, it would allow use of a transfer standard and California would not be able to fully support it. She noted that the State of California had completed some comparison testing using the following different test methods: "pressure volume temperature," "gravimetric," and "master meter." Of the three methods compared, the master meter performed worst.

Several regulatory officials and one industry representative commented in support of the continued development of the two items. That industry representative also noted that the NIST Handbook 44 definition of "transfer standard" needs to be expanded.

Mr. Keilty, in response to Ms. Butcher and Mr. Oppermann's comments, stated that he agreed completely. Adding the paragraph to these two codes is a step towards allowing the use of transfer standards, and it's understood there's a number of things that would need to be in place in order that they be considered suitable for use in testing. He further noted that a change to the tolerances in these two codes is not being proposed.

**Regional Association Meetings:**

Interim 2014 Meeting: The CWMA received comments questioning the accuracy of a meter used as a mobile standard. CWMA forwarded the item to NCWM, recommending it as a Developing item. At the 2015 CWMA Annual Meeting, an official from Nebraska reported the state's use of a master meter (transfer standard). The CWMA again recommended moving the item forward as a Developing item.

WWMA 2014 Annual Meeting: The testimony was presented stating this type of technology would more easily facilitate inspections. However, it was also stated that a more comprehensive evaluation of the equipment and testing procedure, including the associated uncertainty, needs to be performed. The WWMA agreed that this type of technology would be useful. WWMA forwarded the item to NCWM and recommended that it be a Developing item to allow the submitter to provide a more complete analysis.

Annual 2014 Meeting: The SWMA heard questions and concerns that need to be addressed by the submitter. SWMA also recommended that NIST OWM continue to develop a standard for this type of equipment and other guidance documents necessary to recognize their use. Additionally, the SWMA recommended that the submitter work with

NIST, OWM to address these concerns. The SWMA recommended that Items 332-2 and 337-3 be combined into one agenda item since they are both related to test drafts. Comments were heard for both of these agenda items at the same time.

NEWMA 2014 Interim Meeting: NEWMA reported that it believed this item has merit but needs further Development before being sent to a vote. NEWMA forwarded the item to NCWM and recommended that it be a Developing item. NEWMA also recommended that this item be combined with Items 332-2 and 337-3 as a single agenda item. At the 2015 NEWMA Annual Meeting, a recommendation was made to Withdraw this item with the intent that it be resubmitted once clarification has been provided regarding the accuracy of the transfer standard meters. NEWMA agreed, however, to maintain the Developing status at the recommendation of NEWMA's S&T Committee so work could continue on the proposal.

Additional letters, presentations, and data may have been part of the Committee's consideration. To review the supporting documentation, please refer to the *Report of the 99<sup>th</sup> National Conference on Weights and Measures* (SP1193, 2014).

### 337 MASS FLOW METERS

- 337-1 V **Appendix D – Definitions: Diesel Liter Equivalent (DLE) and Diesel Gallon Equivalents (DGE) for Compressed Natural Gas and Liquefied Natural Gas; Definition of Gasoline Gallon Equivalent and Gasoline Liter Equivalent for Compressed Natural Gas; S.1.2. Compressed Natural Gas and Liquefied Natural Gas Dispensers; S.1.3.1.1. Compressed Natural Gas Used as an Engine Fuel; S.1.3.1.2. Liquefied Natural Gas Used as an Engine Fuel; S.5.2. Marking of Diesel and Gasoline Volume Equivalent Conversion Factor; Compressed Natural Gas, S.5.3. Marking of Diesel Volume Equivalent Conversion Factor; Liquefied Natural Gas; UR.3.1.1. Marking of Equivalent Conversion Factor for Compressed Natural Gas; UR.3.1.2. Marking of Equivalent Conversion Factor for Liquefied Natural Gas; and UR.3.8. Return of Product to Storage, Retail Compressed Natural Gas and Liquefied Natural Gas**

(This item was returned to Committee for further consideration due to a split vote.)

**Source:**

Clean Vehicle Education Foundation (2014)

**Purpose:**

Since natural gas is sold in the retail market place as compressed natural gas (CNG) and liquefied natural gas (LNG), alternative fuels to gasoline and diesel fuel, the proposed additions and edits to NIST Handbook 44 will provide definitions for volume units of CNG and LNG that are the energy equivalents for diesel and/or gasoline gallons so that end users can readily compare cost and fuel economy. At present only equivalents for gasoline are included in NIST Handbooks 44 and 130 for CNG as an engine fuel. The proposal also includes modifications to NIST Handbook 44, Appendix D relative to the sale of LNG and CNG.

**Item Under Consideration:**

Amend NIST Handbook 44, Appendix D to include the following new definition:

**diesel gallon equivalent (DGE). – Diesel gallon equivalent (DGE) means 6.384 pounds of compressed natural gas or 6.059 pounds of liquefied natural gas. [3.37]**

**(Added 20XX)**

Amend NIST Handbook 44, Appendix D definitions as follows:

**gasoline gallon equivalent (GGE).** – Gasoline gallon equivalent (GGE) means 5.660 pounds of compressed natural gas. [3.37]

(Added 1994) (Amended 20XX)

Delete the following NIST Handbook 44 Appendix D definition as shown:

~~**gasoline liter equivalent (GLE).** – Gasoline liter equivalent (GLE) means 0.678 kilograms of natural gas.~~ [3.37]

~~(Added 1994)~~

Amend NIST Handbook 44 Mass Flow Meters Code Paragraphs S.1.2., S.1.3.1.1., S.5.2., and UR.3.8. and add new Paragraphs S.1.3.1.2., S.5.3., UR.3.1.1., and UR.3.1.2. as follows:

**S.1.2. Compressed Natural Gas and Liquefied Natural Gas Dispensers.** – Except for fleet sales and other price contract sales, a compressed or liquefied natural gas dispenser used to refuel vehicles shall be of the computing type and shall indicate the quantity, the unit price, and the total price of each delivery. The dispenser shall display the mass measured for each transaction either continuously on an external or internal display accessible during the inspection and test of the dispenser, or display the quantity in mass units by using controls on the device.

(Added 1994) (Amended 20XX)

**S.1.3. Units.**

**S.1.3.1.1. Compressed Natural Gas Used as an Engine Fuel.** – When compressed natural gas is dispensed as an engine fuel, the delivered quantity shall be indicated in “gasoline liter equivalent (GLE) units” or “gasoline gallon equivalent (GGE) units” or diesel gallon equivalent units (DGE), or in mass. (Also see Appendix D definitions.)

(Added 1994) (Amended 20XX)

**S.1.3.1.2. Liquefied Natural Gas Used as an Engine Fuel.** – When liquefied natural gas is dispensed as an engine fuel, the delivered quantity shall be indicated in diesel gallon equivalent units (DGE) or in mass. (Also see definitions.)

(Added 20XX)

**S.5.2. Marking of Gasoline Volume Equivalent Conversion Factors for Compressed Natural Gas.** – A device dispensing compressed natural gas shall have either the statement “1 Gasoline Liter Equivalent (GLE) is Equal to 0.678 kg of Natural Gas” or “1 Gasoline Gallon Equivalent (GGE) is Equal means 5.660 lb of Compressed Natural Gas” or “1 Diesel Gallon Equivalent (DGE) means 6.384 lb of Compressed Natural Gas” permanently and conspicuously marked on the face of the dispenser according to the method of sale used.

(Added 1994) (Amended 20XX)

**S.5.3. Marking of Equivalent Conversion Factors for Liquefied Natural Gas.** – A device dispensing liquefied natural gas shall have the statement “1 Diesel Gallon Equivalent (DGE) means 6.059 lb of Liquefied Natural Gas” permanently and conspicuously marked on the face of the dispenser according to the method of sale used.

(Added 20XX)

**UR.3.1.1. Marking of Equivalent Conversion Factors for Compressed Natural Gas.** – A device dispensing compressed natural gas shall have either the statement “1 Gasoline Gallon Equivalent (GGE) means 5.660 lb of Compressed Natural Gas” or “1 Diesel Gallon Equivalent

**(DGE) means 6.384 lb of Compressed Natural Gas” permanently and conspicuously marked on the face of the dispenser according to the method of sale used.**

**(Added 20XX)**

**UR.3.1.2. Marking of Equivalent Conversion Factors for Liquefied Natural Gas. – A device dispensing liquefied natural gas shall have the statement “1 Diesel Gallon Equivalent (DGE) means 6.059 lb of Liquefied Natural Gas” permanently and conspicuously marked on the face of the dispenser according to the method of sale used.**

**(Added 20XX)**

**UR.3.8. Return of Product to Storage, Retail Compressed and Liquefied Natural Gas Dispensers. –**

Provisions at the site shall be made for returning product to storage or disposing of the product in a safe and timely manner during or following testing operations. Such provisions may include return lines, or cylinders adequate in size and number to permit this procedure.

(Added 1998) **(Amended 20XX)**

**Background/Discussion:**

The gasoline gallon equivalent (GGE) unit was defined by the NCWM in 1994 to allow users of natural gas vehicles to readily compare costs and fuel economy of light-duty, compressed natural gas-powered vehicles with equivalent gasoline powered vehicles. More background on this work is available in the Reports of the 78th and 79<sup>th</sup> NCWM in NIST Special Publication 854 and 870 (see pages 322 and 327, respectively). Natural gas is sold as a vehicle fuel as either Compressed Natural Gas (CNG) or Liquefied Natural Gas (LNG). For medium- and heavy-duty natural gas vehicles in widespread use today, there is a need to officially define a unit allowing a comparison of cost and fuel economy with diesel-powered vehicles. The submitter stated that the official definition of a “Diesel Liter Equivalent” (DLE) and a DGE will likely provide justification for California, Wisconsin, and many other states to permit retail sales of CNG for heavy-duty vehicles in these convenient units. The submitter has provided a mathematical justification for the specific quantity (mass) of CNG in a DLE and in a DGE, which is included in Appendix F.

**2013: A summary of actions that took place in 2013 appears in the box below. January 2013 NCWM Interim Meeting:**

At the 2013 NCWM Interim Meeting, the Committee heard multiple comments in opposition and no comments in support of the proposal during its Open Hearings. Refer to the Committee’s 2013 Final Report to view specific comments and suggestions that were made and who provided them.

During its work sessions at the Interim Meeting, the S&T Committee met with the L&R Committee to discuss this item and related items on the two Committees’ Agendas; the corresponding items on the L&R Committee Agenda are Items 232-1 and 237-1. During the joint meeting, the L&R Committee advised the S&T Committee that it had decided to make the related item on their agenda Informational items to allow additional time for the community to study the issue and hear from other stakeholders in the community. A proposal was made to ask the FALS to deliberate on an appropriate equivalent value for each of the proposed “units.” However, the two Committees recognized that before asking the FALS to expend resources on further definitions, the questions and concerns raised in the Open Hearings regarding the appropriateness of recognizing such units should first be addressed. The Committees agreed to recommend to the NCWM Chairman that a small task group be established to further study this issue. The Committees each agreed to develop a list of tasks that they would ask such a task group to take on and to recommend possible members of the group to ensure balanced representation of stakeholders.

After discussion with the L&R Committee, the S&T Committee reviewed and summarized key comments made during the Open Hearings for S&T Committee Agenda Items 337-1 and 337-2:

- Are equivalent units necessary to promote consumer acceptance of this fuel?
- Is there a significant need for continued comparison to other fuels once you have purchased a vehicle? Does this justify the proliferation of “equivalent” values?

- The intent is to add this for medium- and heavy-duty vehicles such as trucks that operate on LNG. Trucks that operate on LNG are generally dedicated fuel vehicles that run only on a single fuel.
- Is the dispenser the appropriate place to make comparisons with other fuels or is a better place to make those comparisons via mechanisms such as pump toppers, websites, etc.?
- Striking the word “compressed” (in the changes proposed in Item 337-2) expands the proposal to LNG.
- California’s approval of LNG meters indicating in mass units was correct.
- What will the impact be on existing approval of LNG dispensers currently indicating in mass?
- There is much opposition to the proliferation of “equivalent units” for various types of fuels.
- The current recognition of GGE and GLE units has led to complaints about equivalent values from both industry and regulatory officials.
- Mass units should be considered for natural gas and other fuels.
- Will the establishment of equivalent values provide traceability to SI units?
- The community expends significant resources to achieve good meter performance and establishing “fuzzy” equivalent values seems to undermine these efforts.
- The factor for any “equivalent unit” will represent only an “estimate” of an equivalent value.
- There is disagreement amongst the industry regarding the appropriate equivalent value in this proposal. The report containing the data that is referenced as the basis for the proposal includes a disclaimer from Oakridge National Laboratory and U.S. Department of Energy regarding its validity for other than general use in the transportation industry.
- The S&T Committee only heard comments in opposition to the proposal.
- Harmonization with OIML requirements should be considered in the method of sale and associated device requirements.

With respect to Items 337-1 and 337-2, the Committee agreed to work collaboratively with the L&R Committee and to develop a small WG to decide: 1) whether or not DLE and DGE should be considered an acceptable method of sale for natural gas; and 2) if so, what the factor should be to determine their equivalents to gasoline. The Committee agreed the above list of key points and questions heard during its Open Hearings should be considered, along with other Open Hearing comments, by the chairs of both the L&R and S&T Committees in the development of a list of points to be addressed by the Task Group.

Prior to the 2013 Annual Meeting, NCWM Chairman, Mr. Steve Benjamin (North Carolina), appointed the “NCWM Natural Gas Steering Committee (NGSC),” which will be chaired by Mr. Mahesh Albuquerque (Colorado). The primary charge of the Committee is to educate the membership regarding the technical issues surrounding this application, the rationale for the proposed changes, and the anticipated impact of the proposed changes and issues related to their implementation. The Committee was asked to identify and address questions raised during the 2013 Interim Meeting as well as other venues in an effort to enable NCWM members to make informed decisions about proposals under consideration in this area.

Also prior to the 2013 Annual Meeting, the Committee received a proposal from Mr. Douglas Horne (Clean Vehicle Education Foundation) to modify the “Item Under Consideration.” Mr. Horne proposed separate definitions for CNG and LNG gallon equivalent values. The Committee suggested he work with the Steering Committee to further



refine the proposal and suggest changes to the item as appropriate. Mr. Horne's proposals were posted on the NCWM website with other documents relative to the Committee's final report. While submitted in an NCWM Form 15 template, Mr. Horne's proposal is not addressing a new issue, but rather providing comments on a current item (337-1) on the Committee's Agenda.

**July 2013 NCWM Annual Meeting:**

During its 2013 Annual Meeting Open Hearings, the Committee heard an update from the NGSC Chairman, Mr. Albuquerque. He reported that the NGSC met for the first time on Sunday, July 14 at the beginning of the Annual Meeting and gathered input from those in the audience. Comments indicated that consumers may find gallon equivalent information to be helpful, but the most equitable method for measuring and selling the product is based on mass measurement.

At that Meeting, the Committee heard comments on Items 337-1 and 337-2 jointly. Details of those comments are outlined below.

The S&T Committee heard overwhelming comments opposing the use of gallon equivalents and favoring the use of mass as the method of sale. The Committee also heard multiple comments indicating concern about the establishment of a value that would be an approximation of the actual equivalent for a given transaction. Mr. Horne reported that some states have already or are in the process of enacting defined "gasoline equivalent" values; some adopted earlier versions of the equivalent and some are considering new values as outlined in Mr. Horne's most recent proposal.

Ms. Kristin Macey (California) noted that the NCWM successfully adopted a method of sale for hydrogen fuel based on mass and suggested that the natural gas be held to the same standard. Mr. Michael Keilty (Endress + Hauser Flowtec AG USA) commented that sale of natural gas as a vehicle fuel has proliferated globally and those sales are based on mass units.

NIST, OWM acknowledged appreciation of the establishment of the Steering Committee to further study this issue. NIST, OWM encouraged the S&T Committee, the Steering Committee, and the weights and measures community to consider the points raised by OWM during the 2013 Interim Meeting as well as the following in their deliberations of Item 337-1 and Item 337-2:

In addition to discussing the proposals in Items 337-1 and 337-2, OWM requested that the Steering Committee specifically discuss and consider whether or not the continued use of the terms "GLE" and "GGE" are appropriate for commercial CNG metering applications. OWM makes this request based on many of the same points made by OWM at the 2013 Interim Meeting and also given that:

- (1) this market is well established and consumer confidence and acceptance of CNG and other alternative fuels are not contingent upon continued comparisons with gasoline;
- (2) there are other methods for comparing relative efficiency and costs with gasoline;
- (3) experience with feedback from the community indicates problems with the application and validity of these units with changing gas supplies;
- (4) the proposal in Items 337-1 and 337-2 proposes language which would address natural gas as a whole and it is, therefore, appropriate to raise the discussion of whether or not the continued use of non-traceable units is appropriate. Additionally, OWM suggests that a proposal to eliminate the use of the terms "GLE" and "GGE" in favor of indications in mass units be developed and considered by the NCWM to ensure commercial transactions for natural gas are based on NIST-traceable units of measurement; and

- (5) as the number of viable alternative fuel options increase, providing a relatively static comparison with only one alternative fuel will not serve the broad needs of consumers and will make it unlikely that the dispenser is the appropriate location to provide comparison information.

The Committee also heard a comment from Mr. Karimov suggesting that volume units be permitted as a method of sale for LNG.

While many people expressed an understanding of the need for consumers to make comparisons with gasoline, comments indicate that such comparisons would typically be made prior to the purchase of a vehicle and possibly for a short time while becoming accustomed to the vehicle. The Committee heard comments indicating that weights and measures officials would be amenable to permitting the posting or displaying of supplemental information regarding gallon equivalent values.

#### **January 2014 NCWM Interim Meeting:**

The Committee met with the L&R Committee to discuss the comments received on Items 337-1 through 337-5 and corresponding items on the L&R Committee's Agenda. Although there were three new proposals on the agenda, several appear to require clarification from the submitter on whether they are replacements for several carryover proposals. The two Committees heard an update from Mr. Albuquerque, speaking as Chairman of the NGSC on the work of the group.

Ms. Juana Williams (NIST, OWM) reviewed the following points prepared by NIST, OWM and suggested that the Committees consider these points in their deliberations on the proposals:

- OWM encourages the:
  - Efforts of the NGSC as it works to provide corresponding proposals to the L&R Committee and S&T Committee.
  - Collaboration with FALS on:
    - Fuel properties data
    - The final vetting of data, formulas, etc. used to arrive at any conversion factors that might be recognized for use in supplemental advertising/sales information
- NIST, OWM notes that some of the current wording in the 2012 and 2013 proposals is somewhat confusing, in part, because several paragraphs include previous conversion factors no longer under consideration.
- The latest proposal encourages a proliferation of equivalent units of measurement, at least six for the CNG and LNG RMFD applications.
- Measurement accuracy and traceability are not achieved through computation of the sale's information in equivalent quantity units since the conversion factor is an estimated value.
- NIST, OWM suggests input from stakeholders such as the CNG and LNG RMFD OEMs and agencies regulating other Sectors (such as the motor fuels taxation departments) in the natural gas infrastructure on the impact of any new proposal.
- NIST, OWM suggests the Committees consider that additional work might be necessary to further modify the code to fully recognize the LNG application. NIST has plans to outline an approach for a similar project.

The S&T Committee and L&R Committee agreed with the suggestions provided by the NGSC for addressing these items. As a result of these discussions, the S&T Committee agreed to the following regarding Items 337-1 through 337-5 on the Committee's 2014 Interim Agenda:

- Withdraw Items 337-1 and 337-4 and consolidate the remaining three items (Items 337-2, 337-3, and 337-5) into a single item.
- Ask that the NGSC rework its proposed changes to NIST Handbook 44 to reflect the comments heard during the Committee's Open Hearings and in writing.
- Designate the consolidated item as a Voting item in anticipation that the NGSC will present a revised version of the proposed changes to NIST Handbook 44 prior to the publication of the Committee's Interim Report.

If the revised version of the code is not presented prior to the publication date or agreement cannot be reached within the NGSC or the S&T Committee on the revised version, the Committee agreed to designate this consolidated item as an Information item.

#### **March 2014 NGSC Report to the L&R and S&T Committees:**

The NGSC was formed in July 2013 to help understand and educate the NCWM membership regarding the technical issues surrounding the proposed changes to NIST Handbooks 44 and 130 submitted by the Clean Vehicle Education Foundation (CVEF); the anticipated impact of the proposed changes; and issues related to implementation requirements when compressed natural gas (CNG) and liquefied natural gas (LNG) are dispensed and sold as a retail engine fuel in gallon equivalent units.

NCWM 2014 Interim Meeting: Mr. Albuquerque, Chair of the NGSC, provided the S&T and L&R Committees with an update from the NGSC, including proposed revisions to the proposals submitted by the CVEF. The NGSC heard comments from the floor related to the proposed revisions and requested additional time to further develop its recommendations. The S&T and L&R Committees agreed to allow the NGSC additional time to meet and develop alternative proposals to those on the S&T and L&R Committee's January 2014 Agendas, with the expectation that the NGSC recommendations would be ready for inclusion in NCWM Publication 16 and moved forward as a Voting item at the July 2014 NCWM Annual Meeting. Mr. Albuquerque provided the following summary of the NGSC discussions.

#### **Summary of NGSC Meeting Discussions:**

The NGSC met weekly following the January 2014 Interim Meeting and focused on modifying the Clean Vehicle Education Foundation's (CVEF's) 2013 proposals for the recognition of diesel gallon equivalent (DGE) units for CNG/LNG dispenser indications and the method of sale for these two natural gas alternative engine fuels. The NGSC reviewed multiple modifications to those proposals including:

- limiting sales to a single unit of mass measurement, enforceable by 2016;
- requiring indications in mass and gasoline and diesel gallon equivalents, while phasing in mass-only units;
- require sale by mass as the primary means, but allow for the simultaneous display of volume equivalent units, so long as the purchaser always had access to the mass (traceable) measurement; and
- a proposal from NIST OWM which would allow the posting of supplemental information to assist consumers in making value comparisons and for use by taxation/other agencies, but requiring the phase in of indications in mass.

The NGSC received:

- input from DOE on the latest edition of the DOE Transportation Energy Data Book: Edition 32, July 2013 available on the Oak Ridge National Laboratory website at: <http://cta.ornl.gov/data/index.shtml>;

- updates from CNG (3) and LNG (1) dispenser manufacturers indicating their dispensing systems comply with the requirements in the handbooks and have the capability to indicate a sale in a single unit of measurement, and any further input on adding displays to the cabinet for additional units would require further cost analysis; one OEM indicated use of their LNG RMFD in a fleet operation where indications are only in the DGE; and
- feedback from NGSC committee members related to the pros and cons of requiring the indication of sale in mass or gallon equivalent units, including traceability, equipment capabilities, marketplace considerations, and units used by state and federal agencies.

Also noted in the NGSC discussions were:

- how a gallon equivalent unit is derived using energy content, and that the gallon equivalent is defined and measured in terms of mass, not volume;
- for the last 20 years, NIST Handbooks 44 and 130 have required all dispensing equipment to indicate deliveries of natural gas in GGE units to consumers and in mass units for inspection and testing purposes. CNG RMFD equipment in most states comply with the requirements in the handbooks;
- international practices for indicating CNG and LNG engine fuel deliveries are predominantly mass; Canada requires LNG indications in the kilogram and the corresponding OIML R 139 “Compressed gaseous fuel measuring systems for vehicles” standard requires indication of the measured gas in mass;
- the variations in engine efficiency relative to a single conversion factor based on an averaged energy content for LNG;
- the primary focus of the driving public and fleets is on mileage rather than petroleum products no longer used to fuel their vehicles;
- the work ahead over the next year by ASTM committees to develop current CNG and LNG fuel quality standards which will need to be referenced in NIST Handbook 130;
- differences in the measurement of the gallon and kilogram -- since the gallon is a volume measurement and not an energy measurement;
- the NIST Handbook 44, Mass Flow Meters Code includes a requirement for volume-measuring devices with ATC used in natural gas applications to be equipped with an automatic means to make corrections, if the device is affected by changes in the properties of the product; it was also noted that U.S. gasoline and diesel dispensers are not required to have ATC, whereas ATC does occur in sales at the wholesale level;
- how traceability applies to the measurement results at each level of the custody chain (to include the determination of the uncertainty of all calibrations and use of an appropriate unit of measurement); and
- the capabilities of equipment in the marketplace.

A DOE representative supported the use of gallon equivalents and pointed out that they are used in the DOE Transportation Energy Data Book. The DOE representative also pointed out that other federal agencies including the IRS were requiring use of gallon equivalent units for reporting purposes.

Industry representatives on the NGSC indicated that they are actively campaigning to their state and federal offices, encouraging each government branch to recognize sales of CNG and LNG in gasoline and diesel volume equivalent units. Industry Sectors represented on the NGSC indicated that their customers are satisfied with the averaged fuel energy values that correspond to the conversion factors for CNG and LNG, with only one exception. The exception

was a truck stop chain indicating their customers would be amenable to a single conversion factor for both fuels. The CVEF also provided a comparison of GTI's 1992 study results and preliminary data from a 2013 study. The CVEF reported the constituents in natural gas as basically unchanged over 21 years since the NCWM first recognized the GGE. Industry unanimously opposed a recommendation for phasing in mass as the only unit of measurement, noting also that U.S. drivers would be confused by SI units while acknowledging that the United States is in the minority of countries, whereby delivery and sales are by equivalent units. At the conclusion of the NGSC deliberations NGV America provided the following statement:

One of the major advantages of the proposal as currently drafted with inclusion of the DGE and GGE units for natural gas is that this is a proposal that the natural gas industry can support. It further recognizes what is already the preferred practice for how natural gas is measured and dispensed. The latest proposal with DGE and GGE units provides a pathway forward toward a national consensus approach. If the proposal were to instead require use of kilograms or even pounds as the primary method of sale, industry would not support that proposal and likely would strongly oppose it this summer if NCWM were to consider it as a voting issue. Also, if NCWM finalizes on a standard that does not include DGE or GGE, industry is committed to pursuing adoption of an alternative standard on a state by state basis, which could lead to different treatment across the country. Several states have already introduced legislation to recognize the DGE standard (California, Illinois, Missouri, and Virginia) and I expect more will do so later this year. And, you know Colorado and Arkansas already have put in place standards that recognize the DGE units.

#### **NGSC Recommendations:**

- 1) After consideration of all of the above, the NGSC recommends alternate proposals to the L&R and S&T Committee Agenda Items which further modify and consolidate the Clean Vehicle Education Foundation 2013 proposals to include: requirements for measurement in mass and indication in gallon equivalent units (NIST Handbook 44, Paragraphs S.1.3.1.1. and S.1.3.1.2.; and NIST Handbook 130, Paragraphs 3.11.2.1. and 3.12.2.1.);
- 2) posting of a label that has both the GGE and DGE or the GLE and DLE for CNG applications (NIST Handbook 44, Paragraphs S.5.2., S.5.3., UR.3.1.1., and UR.3.1.2; and NIST Handbook 130, Paragraphs 3.11.2.2.2. and 3.12.2.2.2.);
- 3) expression of all equivalent conversion factors expressed in mass units to three significant places beyond the decimal point for consistency (NIST Handbook 44, Paragraphs S.5.2., S.5.3., UR.3.1.1., and UR.3.1.2 and Appendix D and NIST Handbook 130 Section 1, Paragraphs 3.11.2.2.2. and 3.12.2.2.2.);
- 4) correction of the temperatures in the LNG definition (NIST Handbook 130, Section 1);
- 5) addition of 16 CFR Part 309 for CNG automotive fuel rating (NIST Handbook 130 paragraph 3.11.2.2.5.); and
- 6) reference to NFPA 52 (NIST Handbook 130 paragraph 3.12.2.2.4.)

With regards to NIST Handbook 44, the NGSC recommends withdrawing S&T Agenda Items 337-1 and 337-4 and the consolidation of Agenda Items 337-2, 337-3, and 337-5 into a newly revised single Voting item designated as Item 337-2. The NGSC also recommends further modifications to corresponding NIST Handbook 130 proposals to align the definitions of related terms and method of sale with definitions, indicated delivery, and dispenser labeling requirements with those being proposed for NIST Handbook 44.

With regards to NIST Handbook 44, the NGSC also recommends consideration of new a Developing item addressing proposed changes to paragraph S.3.6. Automatic Density Correction designated as Item 360-4. This new proposal is consistent with the NGSC decision to encourage further work beyond the current scope of its work on the CVEF's proposals to fully address all LNG applications.

Representatives of the NGSC and the S&T and L&R Committees met in March 2014; all agreed on the course of action outlined above.

Additional Contacts: Clean Energy, Seal Beach, California; NGVAmerica, Washington, D.C.; and Clean Vehicle Education Foundation, Acworth, Georgia. Regional Association Comments: Fall 2013 input on the Committee's 2014 Interim Agenda Items 337-1 through 337-5.

Based on the NGSC's recommendation, the Committee agreed to modify the original proposal and present the following for a Vote at the 2014 NCWM Annual Meeting as shown below:

Amend NIST Handbook 44, Appendix D to include new definitions as follows:

**diesel gallon equivalent (DGE). – means 6.380 pounds of compressed natural gas or 6.060 pounds of liquefied natural gas. [3.37]**

**(Added 20XX)**

**diesel liter equivalent (DLE). – means 0.765 kilograms of compressed natural gas or 0.726 kilograms of liquefied natural gas. [3.37]**

**(Added 20XX)**

Amend NIST Handbook 44 Appendix D definitions as follows:

**gasoline gallon equivalent (GGE).** – Gasoline gallon equivalent (GGE) means 5.660 pounds of **compressed** natural gas. [3.37]

(Added 1994) **(Amended 20XX)**

**gasoline liter equivalent (GLE).** – Gasoline liter equivalent (GLE) means 0.678 kilograms of **compressed** natural gas. [3.37]

(Added 1994) **(Amended 20XX)**

Amend NIST Handbook 44, Mass Flow Meters Code Paragraphs S.1.2., S.1.3.1.1., S.5.2., and UR.3.8. and add new Paragraphs S.1.3.1.2., S.5.3., UR.3.1.1. and UR.3.1.2. as follows:

**S.1.2. Compressed Natural Gas and Liquefied Natural Gas Dispensers.** – Except for non-retail fleet sales and other price contract sales, a compressed natural gas **and liquefied natural gas** dispensers used to refuel vehicles shall be of the computing type and shall indicate the quantity, the unit price, and the total price of each delivery. The dispensers shall display the mass measured for each transaction either continuously on an external or internal display accessible during the inspection and test of the dispensers, or display the quantity in mass units by using controls on the device.

(Added 1994) **(Amended 20XX)**

**S.1.3. Units.**

**S.1.3.1.1. Compressed Natural Gas Used as an Engine Fuel.** – When compressed natural gas is dispensed as an engine fuel, the delivered quantity shall be **measured in mass and** indicated in “gasoline liter equivalent (GLE) units,” “gasoline gallon equivalent (GGE) units,” **diesel liter equivalent (DLE) units, or diesel gallon equivalent (DGE) units** (Also see definitions).

(Added 1994) **(Amended 20XX)**

**S.1.3.1.2. Liquefied Natural Gas Used as an Engine Fuel. – When liquefied natural gas is dispensed as an engine fuel, the delivered quantity shall be measured in mass and indicated in**

**“diesel liter equivalent (DLE) units” or “diesel gallon equivalent (DGE) units” (Also see definitions).**

**(Added 20XX)**

**S.5.2. Marking of Equivalent Conversion Factor for Compressed Natural Gas.** – A device dispensing compressed natural gas shall have either the statements “1 Gasoline Liter Equivalent (GLE) is **Approximately Equal to 0.678 kg of Compressed Natural Gas**” and “**1 Diesel Liter Equivalent (DLE) is Approximately Equal to 0.765 kg of Compressed Natural Gas**” or the statements “1 Gasoline Gallon Equivalent (GGE) is **Approximately Equal to 5.660 lb of Compressed Natural Gas**” and “**1 Diesel Gallon Equivalent (DGE) is Approximately Equal to 6.380 lb of Compressed Natural Gas**” permanently and conspicuously marked on the face of the dispenser according to the method of sale used.

**(Added 1994) (Amended 20XX)**

**S.5.3. Marking of Diesel Volume Equivalent Conversion Factor for Liquefied Natural Gas.** – A device dispensing liquefied natural gas shall have either the statement “**1 Diesel Liter Equivalent (DLE) is Approximately Equal to 0.726 kg of Liquefied Natural Gas**” or “**1 Diesel Gallon Equivalent (DGE) is Approximately Equal to 6.060 lb of Liquefied Natural Gas**” permanently and conspicuously marked on the face of the dispenser according to the method of sale used.

**(Added 20XX)**

**UR.3.1.1. Marking of Equivalent Conversion Factor for Compressed Natural Gas.** – A device dispensing compressed natural gas shall have either the statements “**1 Gasoline Liter Equivalent (GLE) is Approximately Equal to 0.678 kg of Compressed Natural Gas**” and “**1 Diesel Liter Equivalent (DLE) is Approximately Equal to 0.765 kg of Compressed Natural Gas**” or the statements “**1 Gasoline Gallon Equivalent (GGE) is Approximately Equal to 5.660 lb of Compressed Natural Gas**” and “**1 Diesel Gallon Equivalent (DGE) is Approximately Equal to 6.380 lb of Compressed Natural Gas**” permanently and conspicuously marked on the face of the dispenser according to the method of sale used.

**(Added 20XX)**

**UR.3.1.2. Marking of Equivalent Conversion Factor for Liquefied Natural Gas.** – A device dispensing liquefied natural gas shall have either the statement “**1 Diesel Liter Equivalent (DLE) is Approximately Equal to 0.726 kg of Liquefied Natural Gas**” or “**1 Diesel Gallon Equivalent (DGE) is Approximately Equal to 6.060 lb of Liquefied Natural Gas**” permanently and conspicuously marked on the face of the dispenser according to the method of sale used.

**(Added 20XX)**

**UR.3.8. Return of Product to Storage, Retail Compressed Natural Gas and Liquefied Natural Gas Dispensers.** – Provisions at the site shall be made for returning product to storage or disposing of the product in a safe and timely manner during or following testing operations. Such provisions may include return lines, or cylinders adequate in size and number to permit this procedure.

**(Added 1998) (Amended 20XX)**

**July 2014 Annual Meeting:**

NCWM 2014 Annual Meeting: The Committee considered the revised proposal shown above. There were numerous comments both in opposition to and in support of the proposal as follows:

**Support:**

- Numerous letters of support by U.S. Senators and Governors with wide bipartisan support.
- Allows consumers who may be familiar with volumetric units to make value comparisons.
- Allows for cost comparison between multiple fuel types.
- Proposal is supported by those who build and supply the equipment, vehicle manufacturers, and producers and distributors of natural gas.
- If action isn't taken, the decision will be taken out of the Weights and Measures jurisdictions' hands at the state and local levels.
- The GGE has been in use and accepted for many years.
- If the primary method of sale is mass, it dictates price, sale, and advertising be in mass. Mass units are not consumer friendly. Consumers don't understand price per kilogram or pound for fuel sales.
- Industry stated that equivalent units are what consumers want.
- At least one company reported that all of their business is built around the DGE and they would need to retrofit their dispensers if required to measure in mass.
- Natural gas retail dispensers measure in mass and are inspected and tested using mass units.

**Opposition:**

- Use of the word approximate.
- This is marketing rather than a technical issue.
- Will there be potential for proliferation of other equivalent units for other alternative fuels?
- There are questions concerning the validity of the conversion values and whether adequate research has been done to develop the values.
- Including more than one equivalent value could lead to consumer confusion.
- Not aligned with how natural gas is being sold in the rest of the world.
- A jurisdiction stated that consumers hadn't been asked how they want it sold.
- Is there a need for ongoing value comparisons if a vehicle is dedicated to natural gas fuel?
- Measurement science needs to be based on traceable standards. "Equivalent units" are not traceable to NIST standards.
- Consumers may need to make comparisons with multiple different fuel types such as diesel, biodiesel, gasoline, fuel ethanol, electric, hydrogen, LNG, and others. What is the most appropriate means to provide sufficient information to customers attempting to make value comparisons?
- Equivalent units would be better provided as supplemental information rather than the basis for commercial transactions.



**Other technical points that were raised include the following:**

- NTEP certificates have already been issued for five LNG dispensers that measure and indicate in mass units only. How will the proposed changes affect this equipment?

The Committee received an alternative proposal from NIST that would require dispensers to measure, indicate, and calculate the total selling price based on mass units (pounds or kilograms), but permit the posting of supplemental information regarding approximate equivalents to other fuels for use by consumers when making value comparisons or for use by tax agencies. The proposed changes that appear in this alternative proposal are shown below; the Committee was also provided with a draft of the entire Section 3.37. Mass Flow Meters Code showing these changes incorporated into the code. This draft is available upon request from NIST, OWM.

**S.1. Indicating and Recording Elements.**

...

**S.1.2. ~~Compressed~~ Natural Gas Dispensers.** – Except for fleet sales and other price contract sales, a ~~compressed~~ natural gas dispenser used to refuel vehicles shall be of the computing type and shall indicate the quantity, the unit price, and the total price of each delivery. ~~The dispenser shall display the mass measured for each transaction either continuously on an external or internal display accessible during the inspection and test of the dispenser, or display the quantity in mass units by using controls on the device.~~  
(Added 1994) (Amended 20XX)

**S.1.3. Units.**

**S.1.3.1. Units of Measurement.** – Deliveries shall be indicated and recorded in grams, kilograms, metric tons, pounds, tons, and/or liters, gallons, quarts, pints and decimal subdivisions thereof. The indication of a delivery shall be on the basis of apparent mass versus a density of 8.0 g/cm<sup>3</sup>. The volume indication shall be based on the mass measurement and an automatic means to determine and correct for changes in product density.  
(Amended 1993 and 1997)

**S.1.3.1.1. ~~Compressed~~ Natural Gas Used as an Engine Fuel.** – When ~~compressed~~ natural gas is dispensed as an engine fuel, the delivered quantity shall be indicated **as follows:**

*(a) Effective and Nonretroactive as of January 1, 2016, the delivered quantity shall be indicated in mass units in terms of kilograms or pounds and decimal subdivisions thereof.*

This paragraph will become retroactive on January 1, 2017.  
(Added 20XX)

*(b) For dispensers manufactured prior to January 1, 2016, the dispenser shall display the mass measured for each transaction, either continuously on an external or internal display accessible during the inspection and test of the dispenser, or display the quantity in mass units by using controls on the device. The delivered quantity shall be indicated in mass or in “gasoline liter equivalent (GLE) units” or “gasoline gallon equivalent (GGE) units.” (Also see ~~d~~Definitions.)*

(Added 1994) (Amended 20XX)

Paragraph S.1.3.1.1.(b) will be removed in the 2017 edition of NIST Handbook 44 when paragraph S.1.3.1.1.(a) becomes retroactive.

**S.1.3.1.2. Natural Gas Used as an Engine Fuel, Supplemental Information.** – Dispensers of natural gas dispensed as an engine fuel may include supplemental information to assist

consumers in making value comparisons with gasoline and diesel fuel and for use by taxation departments and other agencies that may need an approximation thereof. Supplemental information shall not appear adjacent or in close proximity to the primary display and shall be positioned far enough from that display so as to ensure that the quantity, unit price, and total price for the transaction are clear and easily understood.

Supplemental units shall be clearly designated with the phrase “The following information is provided for comparison with other vehicle fuels and is not to be used as a basis for commercial transactions.”

Supplemental units shall be displayed using one or more of the following statements.

For compressed natural gas:

1 kg of Compressed Natural Gas is Equal to 1.4749 Gasoline Liter Equivalent (GLE)  
1 kg of Compressed Natural Gas is Equal to 0.3896 Gasoline Gallon Equivalent (GGE)  
1 kg of Compressed Natural Gas is Equal to 1.3072 Diesel Liter Equivalent (DLE)  
1 kg of Compressed Natural Gas is Equal to 0.3455 Diesel Gallon Equivalent (DGE)

1 lb of Compressed Natural Gas is Equal to 0.669 Gasoline Liter Equivalent (GLE)  
1 lb of Compressed Natural Gas is Equal to 0.177 Gasoline Gallon Equivalent (GGE)  
1 lb of Compressed Natural Gas is Equal to 0.593 Diesel Liter Equivalent (DLE)  
1 lb of Compressed Natural Gas is Equal to 0.157 Diesel Gallon Equivalent (DGE)

For liquefied natural gas:

1 kg of Liquefied Natural Gas is Equal to 1.3768 Diesel Liter Equivalent (DLE)  
1 kg of Liquefied Natural Gas is Equal to 0.3638 Diesel Gallon Equivalent (DGE)

1 lb of Liquefied Natural Gas is Equal to 0.625 Diesel Liter Equivalent (DLE)  
1 lb of Liquefied Natural Gas is Equal to 0.165 Diesel Gallon Equivalent (DGE)

...

#### S.1.3.3. Maximum Value of Quantity-Value Divisions.

- (a) The maximum value of the quantity-value division for liquids shall not be greater than 0.2 % of the minimum measured quantity.
- (b) Effective and nonretroactive as of January 1, 2016, the maximum value of the mass division for dispensers of natural gas used to refuel vehicles shall not exceed 0.001 kg or 0.001 lb.

Note: Paragraph S.1.3.3.(b) will become retroactive effective January 1, 2017.

- (c) For dispensers of ~~compressed~~ natural gas used to refuel vehicles and manufactured prior to January 1, 2016, the value of the division for the gasoline liter equivalent shall not exceed 0.01 GLE; the division for gasoline gallon equivalent (GGE) shall not exceed 0.001 GGE. The maximum value of the mass division shall not exceed 0.001 kg or 0.001 lb.

Note: Paragraph S.1.3.3.(c) will be removed in the 2017 edition of NIST Handbook 44 when Paragraph S.1.3.3.(b) becomes retroactive.

(Amended 1994 and 20XX)

...

**S.5. Markings. ...**

**S.5.2. Marking of Gasoline Volume Equivalent Conversion Factor. – ~~A device~~ Dispensers manufactured prior to January 1, 2016** dispensing compressed natural gas shall have either the statement “1 Gasoline Liter Equivalent (GLE) is Equal to 0.678 kg of Natural Gas” or “1 Gasoline Gallon Equivalent (GGE) is Equal to 5.660 lb of Natural Gas” permanently and conspicuously marked on the face of the dispenser according to the method of sale used.

**As of January 1, 2017 devices must indicate as specified in S.1.3.1.1.(a) and any information providing equivalent units may only be included as supplemental information as specified in S.1.3.1.2.**

**Paragraph S.5.2. will be removed from the 2017 edition of NIST Handbook 44 when paragraph S.1.3.1.1.(a) becomes retroactive.**

(Added 1994) (~~Amended 20XX~~)

...

**UR.3. Use of Device.**

...

**UR.3.8. Return of Product to Storage, Retail Compressed Natural Gas and Liquefied Natural Gas Dispensers.** – Provisions at the site shall be made for returning product to storage or disposing of the product in a safe and timely manner during or following testing operations. Such provisions may include return lines, or cylinders adequate in size and number to permit this procedure.

(Added 1998) (~~Amended 20XX~~)

Because many of these issues are dependent upon defining the proper method of sale, the Committee met jointly with the L&R Committee to discuss the comments received on the S&T and L&R items relating to natural gas.

The Committee identified the method of sale by mass versus equivalent volumetric units as the most significant concern based on comments heard on this proposal. In addition to support for this proposal, there were also concerns regarding the use of the word “approximately” for labeling purposes; “multiple equivalent units” labeled on the same dispenser; “tax issues;” and other less commonly expressed issues. The Committee decided to eliminate the labeling altogether and not delay the effective date, thereby, addressing all three concerns. Consequently, the Committee agreed to delete proposed Paragraphs S.5.3., UR.3.1.1., and UR.3.1.2. in their entirety from the proposal and existing paragraph S.5.2. from NIST Handbook 44.

Based upon the comments received and its deliberations, the Committee agreed to modify the Item Under Consideration shown in NCWM Publication 16 by deleting the following language:

~~**S.5.2. Marking of Equivalent Conversion Factor for Compressed Natural Gas. – A device dispensing compressed natural gas shall have either the statements “1 Gasoline Liter Equivalent (GLE) is Approximately Equal to 0.678 kg of Compressed Natural Gas” and “1 Diesel Liter Equivalent (DLE) is Approximately Equal to 0.765 kg of Compressed Natural Gas” or the statements “1 Gasoline Gallon Equivalent (GGE) is Approximately Equal to 5.660 lb of Compressed Natural Gas” and “1 Diesel Gallon Equivalent (DGE) is Approximately Equal to 6.384 lb of Compressed Natural Gas” permanently and conspicuously marked on the face of the dispenser according to the method of sale used.**~~

~~(Added 1994) (~~Amended 2014~~)~~

~~**S.5.3. Marking of Diesel Volume Equivalent Conversion Factor for Liquefied Natural Gas. – A device dispensing liquefied natural gas shall have either the statement “1 Diesel Liter Equivalent (DLE)**~~

~~is Approximately Equal to 0.726 kg of Liquefied Natural Gas” or “1 Diesel Gallon Equivalent (DGE) is Approximately Equal to 6.059 lb of Liquefied Natural Gas” permanently and conspicuously marked on the face of the dispenser according to the method of sale used.~~

~~(Added 2014)~~

~~UR.3.1.1. **Marking of Equivalent Conversion Factor for Compressed Natural Gas.**— A device dispensing compressed natural gas shall have either the statements “1 Gasoline Liter Equivalent (GLE) is Approximately Equal to 0.678 kg of Compressed Natural Gas” and “1 Diesel Liter Equivalent (DLE) is Approximately Equal to 0.765 kg of Compressed Natural Gas” or the statements “1 Gasoline Gallon Equivalent (GGE) is Approximately Equal to 5.660 lb of Compressed Natural Gas” and “1 Diesel Gallon Equivalent (DGE) is Approximately Equal to 6.384 lb of Compressed Natural Gas” permanently and conspicuously marked on the face of the dispenser according to the method of sale used.~~

~~(Added 2014)~~

~~UR.3.1.2. **Marking of Equivalent Conversion Factor for Liquefied Natural Gas.**— A device dispensing liquefied natural gas shall have either the statement “1 Diesel Liter Equivalent (DLE) is Approximately Equal to 0.726 kg of Liquefied Natural Gas” or “1 Diesel Gallon Equivalent (DGE) is Approximately Equal to 6.059 lb of Liquefied Natural Gas” permanently and conspicuously marked on the face of the dispenser according to the method of sale used.~~

~~(Added 2014)~~

The Item Under Consideration, absent the language that had been deleted by the Committee, was then offered for vote, but was returned to Committee for further consideration due to a split “Reports of the National Conference on Weights and Measures” Vote. The following proposal is that which was Voted on at the 2014 Annual NCWM Meeting and returned to Committee.

**Proposal presented for vote and returned to Committee at the 2014 NCWM Annual Meeting:**

Amend NIST Handbook 44, Appendix D to include new definitions as follows:

**diesel gallon equivalent (DGE). – means 6.384 pounds of compressed natural gas or 6.059 pounds of liquefied natural gas. [3.37]**

**(Added 20XX)**

**diesel liter equivalent (DLE). – means 0.765 kilograms of compressed natural gas or 0.726 kilograms of liquefied natural gas. [3.37]**

**(Added 20XX)**

Amend NIST Handbook 44, Appendix D definitions as follows:

**gasoline gallon equivalent (GGE).** – Gasoline gallon equivalent (GGE) means 5.660 pounds of **compressed** natural gas. [3.37]

**(Added 1994) (Amended 20XX)**

**gasoline liter equivalent (GLE).** – Gasoline liter equivalent (GLE) means 0.678 kilograms of **compressed** natural gas. [3.37]

**(Added 1994) (Amended 20XX)**

Amend NIST Handbook 44 Mass Flow Meters Code Paragraphs S.1.2., S.1.3.1.1., S.5.2., and UR.3.8. and add new Paragraphs S.1.3.1.2., S.5.3., UR.3.1.1. and UR.3.1.2. as follows:

**S.1.2. Compressed Natural Gas and Liquefied Natural Gas Dispensers.** – Except for non-retail fleet sales and other price contract sales, a compressed natural gas **and liquefied natural gas** dispensers used to

refuel vehicles shall be of the computing type and shall indicate the quantity, the unit price, and the total price of each delivery. The dispensers shall display the mass measured for each transaction either continuously on an external or internal display accessible during the inspection and test of the dispensers, or display the quantity in mass units by using controls on the device.

(Added 1994) (Amended 20XX)

**S.1.3. Units**

**S.1.3.1.1. Compressed Natural Gas Used as an Engine Fuel.** – When compressed natural gas is dispensed as an engine fuel, the delivered quantity shall be measured in mass and indicated in “gasoline liter equivalent (GLE) units,” “gasoline gallon equivalent (GGE) units,” diesel liter equivalent (DLE) units, or diesel gallon equivalent (DGE) units (Also see definitions).

(Added 1994) (Amended 20XX)

**S.1.3.1.2. Liquefied Natural Gas Used as an Engine Fuel.** – When liquefied natural gas is dispensed as an engine fuel, the delivered quantity shall be measured in mass and indicated in “diesel liter equivalent (DLE) units” or “diesel gallon equivalent (DGE) units” (Also see definitions).

(Added 20XX)

**UR.3.8. Return of Product to Storage, Retail Compressed Natural Gas and Liquefied Natural Gas Dispensers.** – Provisions at the site shall be made for returning product to storage or disposing of the product in a safe and timely manner during or following testing operations. Such provisions may include return lines, or cylinders adequate in size and number to permit this procedure.

(Added 1998) (Amended 20XX)

**January 2015 – Separate Compromise Proposals Offered by the NGSC:**

In January 2015 and prior to the 2015 NCWM Interim Meeting, the Committee received a recommendation from the NGSC that the weights and measures community consider two separate proposals as alternatives to the proposal voted on at the 2014 NCWM Annual Meeting. The Steering Committee noted that the two proposals reflect compromises on viewpoints within the NGSC: (1) on the recognition of the LNG motor-fuel application; (2) to replace the term “equal” with the term “means” to establish the relationship of mass units to supplemental units; and (3) to eliminate from use liter equivalent units of measurement in natural gas motor-fuel applications since this is a newly created unit that is not recognized in jurisdictions using SI units.

The first compromise proposal titled “The Volume Equivalent Compromise Proposal” proposes modifications to NIST Handbook 44, Section 3.37. Mass Flow Meters (MFM) Code and corresponding NIST Handbook 130, Method of Sale (MOS) requirements to:

1. Recognize the indication of natural gas fuel sales in values of either volume equivalent units or mass units based on legislative policy within a jurisdiction;
2. Mandate labeling the equivalent unit conversion factor on a natural gas motor-fuel dispenser, and
3. No longer recognize SI mass units (e.g., kg) in favor of U.S. customary mass units (i.e., lb).

The second proposal, originally titled “Natural Gas Motor-Fuel Proposal to Phase-In Mass Indications While Recognizing Supplemental Fuel Information,” but later changed to “The Mass Compromise Proposal” is intended to replace the NIST OWM fall 2014 compromise proposal. This alternate proposal was a joint collaboration of work by Mr. Ron Hayes (Missouri) and NIST OWM to further modify the NIST Handbook 44, 3.37. Mass Flow Meters Code where this proposal:

1. Keeps the suggested *new* phase in period where mass indications for all sales of natural gas motor-fuel will be of a specified maximum value and required for all dispensers effective January 1, 2017, as shown in amended Paragraphs S.1.3.1.1. Compressed Natural Gas Used as an Engine Fuel, and S.1.3.3. Maximum Value of Quantity-Value Divisions;
2. Continues to recognize the use of *new* supplemental fuel information for use in making value comparisons and taxation purposes as well as prescribe the format for stating this information as shown in: (a) the proposed *new* Definition of “diesel gallon equivalent (DGE);” and (b) *new* paragraph S.1.3.1.2. Natural Gas Used as an Engine Fuel, Supplemental Information; and (c) modifications to paragraph S.5.2. Marking of Gasoline Volume Equivalent Conversion Factor. This information might be provided in the form of placards; on the kiosk; or as dispenser indications or labeling on the cabinet when it is clear that this is not the required transaction information; and
3. Recognizes the existing compressed natural gas motor-fuel application and includes the proposed *new* liquefied natural gas motor-fuel application as shown in modified Paragraphs S.1.2. Compressed Natural Gas Dispensers and UR.3.8. Return of Product to Storage.

Both proposals are included in their entirety in the boxes below.

***Proposal 1 – The Volume Equivalent Compromise Proposal:***

**NIST Handbook 44:**

Amend NIST Handbook 44, Appendix D to include new definitions as follows:

**diesel gallon equivalent (DGE). – Diesel gallon equivalent (DGE) means 6.384 pounds of compressed natural gas or 6.059 pounds of liquefied natural gas. [3.37]**

**(Added 20XX)**

Amend NIST Handbook 44, Appendix D – Definitions as follows:

**gasoline gallon equivalent (GGE). – Gasoline gallon equivalent (GGE) means 5.660 pounds of compressed natural gas. [3.37]**

**(Added 1994) (Amended 20XX)**

Amend NIST Handbook 44, Mass Flow Meters Code Paragraphs S.1.2., S.1.3.1.1., S.5.2., and UR.3.8. and add new Paragraphs S.1.3.1.2., S.5.3., UR.3.1.1. and UR.3.1.2. as follows:

**S.1.2. Compressed Natural Gas and Liquefied Natural Gas Dispensers.** – Except for fleet sales and other price contract sales, a compressed **or liquefied** natural gas dispenser used to refuel vehicles shall be of the computing type and shall indicate the quantity, the unit price, and the total price of each delivery. The dispenser shall display the mass measured for each transaction either continuously on an external or internal display accessible during the inspection and test of the dispenser, or display the quantity in mass units by using controls on the device.

**(Added 1994) (Amended 20XX)**

**S.1.3. Units.**

**S.1.3.1.1. Compressed Natural Gas Used as an Engine Fuel.** – When compressed natural gas is dispensed as an engine fuel, the delivered quantity shall be indicated in **“gasoline liter equivalent (GLE) units” or “gasoline gallon equivalent (GGE) units.” or diesel gallon equivalent units (DGE).**

**or in mass if required by the weights and measures authority having jurisdiction.** (Also see definitions.)

(Added 1994) **(Amended 20XX)**

**S.1.3.1.2. Liquefied Natural Gas Used as an Engine Fuel. – When liquefied natural gas is dispensed as an engine fuel, the delivered quantity shall be indicated in diesel gallon equivalent units (DGE), or in mass if required by the weights and measures authority having jurisdiction (Also see definitions.)**

**(Added 20XX)**

**S.5.2. Marking of Gasoline Volume Equivalent Conversion Factors for Compressed Natural Gas. – A device dispensing compressed natural gas shall have either the statement “~~1 Gasoline Liter Equivalent (GLE) is Equal to 0.678 kg of Natural Gas~~” or “1 Gasoline Gallon Equivalent (GGE) is Equal to means 5.660 lb of Compressed Natural Gas” or “1 Diesel Gallon Equivalent (DGE) means 6.384 lb of Compressed Natural Gas” permanently and conspicuously marked on the face of the dispenser according to the method of sale used.**

(Added 1994) **(Amended 20XX)**

**S.5.3. Marking of Equivalent Conversion Factors for Liquefied Natural Gas. – A device dispensing liquefied natural gas shall have the statement “1 Diesel Gallon Equivalent (DGE) means 6.059 lb of Liquefied Natural Gas” permanently and conspicuously marked on the face of the dispenser according to the method of sale used.**

**(Amended 20XX)**

**UR.3.1.1. Marking of Equivalent Conversion Factors for Compressed Natural Gas. – A device dispensing compressed natural gas shall have either the statement “1 Gasoline Gallon Equivalent (GGE) means 5.660 lb of Compressed Natural Gas” or “1 Diesel Gallon Equivalent (DGE) means 6.384 lb of Compressed Natural Gas” permanently and conspicuously marked on the face of the dispenser according to the method of sale used.**

**(Added 20XX)**

**UR.3.1.2. Marking of Equivalent Conversion Factors for Liquefied Natural Gas. – A device dispensing liquefied natural gas shall have the statement “1 Diesel Gallon Equivalent (DGE) means 6.059 lb of Liquefied Natural Gas” permanently and conspicuously marked on the face of the dispenser according to the method of sale used.**

**(Amended 20XX)**

**UR.3.8. Return of Product to Storage, Retail Compressed and Liquefied Natural Gas Dispensers. – Provisions at the site shall be made for returning product to storage or disposing of the product in a safe and timely manner during or following testing operations. Such provisions may include return lines, or cylinders adequate in size and number to permit this procedure.**

(Added 1998) **(Amended 20XX)**

**NIST Handbook 130:**

Amend NIST Handbook 130, Uniform Engine Fuels and Automotive Lubricants Regulation as follows:

**1.XX. Diesel Gallon Equivalent (DGE). – Diesel Gallon Equivalent (DGE) means 6.384 pounds of compressed natural gas or 6.059 pounds of liquefied natural gas.**

**1.25. Gasoline Gallon Equivalent (GGE). – Gasoline Gallon Equivalent (GGE) means to 2.567(5.660 lb of compressed natural gas.**

~~1.26. Gasoline Liter Equivalent (GLE). Equivalent to 0.678 kg (1.495 lb) of natural gas.~~

1.35. **Liquefied Natural Gas (LNG).** – Natural gas that has been liquefied at ~~– 126.4~~ 162 °C (~~– 259~~260 °F) and stored in insulated cryogenic tanks for use as an engine fuel.

### 3.11. Compressed Natural Gas (CNG).

3.11.1. **How Compressed Natural Gas is to be Identified.** – For the purposes of this regulation, compressed natural gas shall be identified by the term “Compressed Natural Gas” or “CNG.”

#### 3.11.2. Retail Sales of Compressed Natural Gas Sold as a Vehicle Fuel.

3.11.2.1. **Method of Retail Sale.** – All CNG kept, offered, or exposed for sale or sold at retail as a vehicle fuel shall be either in terms of the gasoline ~~liter equivalent (GLE) or gasoline~~ gallon equivalent (GGE), the diesel gallon equivalent (DGE), or in mass if required by the weights and measures authority having jurisdiction.

#### 3.11.2.2. Retail Dispenser Labeling.

3.11.2.2.1. **Identification of Product.** – Each retail dispenser of CNG shall be labeled as “Compressed Natural Gas.”

3.11.2.2.2. **Conversion Factor.** – All retail CNG dispensers shall be labeled with the conversion factor in terms of ~~kilograms or~~ pounds. The label shall be permanently and conspicuously displayed on the face of the dispenser and shall have either the statement ~~“1 Gasoline Liter Equivalent (GLE) is equal to 0.678 kg of Natural Gas or”~~ “1 Gasoline Gallon Equivalent (GGE) is equal to means 5.660 lb of Compressed Natural Gas,” or “1 Diesel Gallon Equivalent (DGE) means 6.384 lb of Compressed Natural Gas,” consistent with the method of sale used.

3.11.2.2.3. **Pressure.** – CNG is dispensed into vehicle fuel containers with working pressures of ~~16 574 kPa–20 684 kPa~~ (3,000 psig), or 24 821 kPa (3,600 psig). The dispenser shall be labeled ~~16 574 kPa–20 684 kPa~~ (3,000 psig), or 24 821 kPa (3,600 psig) corresponding to the pressure of the CNG dispensed by each fueling hose.

3.11.2.2.4. **NFPA Labeling.** – NFPA Labeling requirements also apply. (Refer to NFPA 52.)

3.11.3. **Nozzle Requirements for CNG.** – CNG fueling nozzles shall comply with ANSI/AGA/CGA NGV 1.

### 3.12. Liquefied Natural Gas (LNG).

3.12.1. **How Liquefied Natural Gas is to be Identified.** – For the purposes of this regulation, liquefied natural gas shall be identified by the term “Liquefied Natural Gas” or “LNG.”

#### 3.12.2. Retail Sales of Liquefied Natural Gas Sold as a Vehicle Fuel.

3.12.2.1. **Method of Retail Sale.** – All LNG kept, offered, or exposed for sale or sold at retail as a vehicle fuel shall be in terms of the diesel gallon equivalent (DGE), or in mass if required by the weights and measures authority having jurisdiction.

~~3.12.2.3. Labeling of Retail Dispensers of Liquefied Natural Gas Sold as a Vehicle Fuel Labeling.~~



**3.12.23.1. Identification of Product.** – Each retail dispenser of LNG shall be labeled as “Liquefied Natural Gas.”

**3.12.3.2. Conversion Factor.** – All retail LNG dispensers shall be labeled with the conversion factor in terms of pounds. The label shall be permanently and conspicuously displayed on the face of the dispenser and shall have the statement “1 Diesel Gallon Equivalent (DGE) means 6.059 lb of Liquefied Natural Gas.”

**3.12.23.23. Automotive Fuel Rating.** – LNG automotive fuel shall be labeled with its automotive fuel rating in accordance with 16 CFR Part 306.

**3.12.23.34. NFPA Labeling.** – NFPA Labeling requirements also apply. (Refer to NFPA ~~572~~.)

**Proposal 2 – The Mass Compromise Proposal:**

Consider the following modifications to NIST Handbook 44, 3.37. Mass Flow Meters Code:

**S.1.3. Units.**

**S.1.3.1. Units of Measurement.**

...

**S.1.3.1.1. ~~Compressed~~ Natural Gas Used as an Engine Fuel.** – When ~~compressed~~ natural gas is dispensed as an engine fuel, the delivered quantity shall be indicated **as follows:**

*(a) Effective and nonretroactive as of January 1, 2016, the delivered quantity shall be indicated in mass units in terms of kilograms or pounds and decimal subdivisions thereof.*

This paragraph will become retroactive on January 1, 2017.

(Added 20XX)

*(b) The dispenser shall display the mass measured for each transaction, either continuously on an external or internal display accessible during the inspection and test of the dispenser, or display the quantity in mass units by using controls on the device. The delivered quantity shall be indicated in mass or in “gasoline liter equivalent (GLE) units” or “gasoline gallon equivalent (GGE) units.” (Also see ~~d~~Definitions.)*

(Added 1994) (Amended 20XX)

Paragraph S.1.3.1.1.(b) will be removed in the 2017 edition of NIST Handbook 44 when paragraph S.1.3.1.1.(a) becomes retroactive.

**S.1.3.2. Numerical Value of Quantity-Value Divisions.** – The value of a scale interval shall be equal to:

...

**S.1.3.3. Maximum Value of Quantity-Value Divisions.**

(a) The maximum value of the quantity-value division for liquids shall not be greater than 0.2 % of the minimum measured quantity.

- (b) Effective and nonretroactive as of January 1, 2016, the maximum value of the mass division for dispensers of natural gas used to refuel vehicles shall not exceed 0.001 kg or 0.001 lb.

Note: Paragraph S.1.3.3.(b) will become retroactive effective January 1, 2017.

- (c) For dispensers of ~~compressed~~ natural gas used to refuel vehicles and manufactured prior to January 1, 2016, the value of the division for the ~~gasoline liter equivalent shall not exceed 0.01 GLE; the division for~~ gasoline gallon equivalent (GGE) shall not exceed 0.001 GGE. The maximum value of the mass division shall not exceed 0.001 kg or 0.001 lb.

Note: Paragraph S.1.3.3.(c) will be removed in the 2017 edition of NIST Handbook 44 when Paragraph S.1.3.3.(b) becomes retroactive.

(Amended 1994 and 20XX)

Include a new definition for the supplemental term diesel gallon equivalent as follows:

A Diesel Gallon Equivalent (DGE) means 6.384 pounds (2.895 kg) of CNG or 6.059 pounds (2.748 kg) of LNG.

(Added 20XX)

Add a new paragraph S.1.3.1.2. as shown below:

S.1.3.1.2. Natural Gas Used as an Engine Fuel, Supplemental Information. – Dispensers of natural gas dispensed as an engine fuel may include supplemental information to assist consumers in making value comparisons with gasoline and diesel fuel and for use by taxation departments and other agencies that may need an approximation thereof. Quantity, unit price, and total price for the transaction must be clearly designated and distinguished from any supplemental information to ensure that the customer understands the basis for the transaction.

Supplemental units shall be clearly designated with the phrase “The following information is provided for comparison with other vehicle fuels and is not to be used as a basis for commercial transactions.”

Supplemental units shall be displayed using one or more of the following statements.

For compressed natural gas:

1 kg of Compressed Natural Gas means 0.3896 Gasoline Gallon Equivalent (GGE)

1 kg of Compressed Natural Gas means 0.3455 Diesel Gallon Equivalent (DGE)

1 lb of Compressed Natural Gas means 0.177 Gasoline Gallon Equivalent (GGE)

1 lb of Compressed Natural Gas means 0.157 Diesel Gallon Equivalent (DGE)

A Gasoline Gallon Equivalent (GGE) means 5.660 pounds (2.567 kg) of CNG

For liquefied natural gas:

1 kg of Liquefied Natural Gas means 0.3638 Diesel Gallon Equivalent (DGE)

1 lb of Liquefied Natural Gas means 0.165 Diesel Gallon Equivalent (DGE)

A Diesel Gallon Equivalent means 6.059 pounds (2.748 kg) of LNG

Modify paragraph S.5.2. as follows:

**S.5.2. Marking of Gasoline Volume Equivalent Conversion Factor.** – A device dispensing compressed natural gas shall have ~~either~~ the statement ~~“1 Gasoline Liter Equivalent (GLE) is Equal to 0.678 kg of~~

~~Natural Gas~~ or “1 Gasoline Gallon Equivalent (GGE) is ~~Equal to~~ means 5.660 lb of Natural Gas” permanently and conspicuously marked on the face of the dispenser according to the method of sale used.

**Paragraph S.5.2. will be removed from the 2017 edition of NIST Handbook 44 when paragraph S.1.3.1.1.(a) becomes retroactive.**

(Added 1994) (**Amended 20XX**)

Amend the following NIST Handbook 44, paragraphs as recommended in Fall 2014:

**S.1. Indicating and Recording Elements.**

...

**S.1.2. ~~Compressed Natural Gas Dispensers.~~** – Except for fleet sales and other price contract sales, a ~~compressed~~ natural gas dispenser used to refuel vehicles shall be of the computing type and shall indicate the quantity, the unit price, and the total price of each delivery. ~~The dispenser shall display the mass measured for each transaction either continuously on an external or internal display accessible during the inspection and test of the dispenser, or display the quantity in mass units by using controls on the device.~~

(Added 1994) (**Amended 20XX**)

**UR.3. Use of Device.**

...

**UR.3.8. Return of Product to Storage, Retail Compressed Natural Gas and Liquefied Natural Gas Dispensers.** – Provisions at the site shall be made for returning product to storage or disposing of the product in a safe and timely manner during or following testing operations. Such provisions may include return lines, or cylinders adequate in size and number to permit this procedure.

(Added 1998) (**Amended 20XX**)

The NGSC representatives ask that the “Natural Gas Motor Fuel Proposal to Phase-In Mass Indications While Recognizing Supplemental Fuel Information” shown above be considered on its merits for adhering to basic weights and measures philosophy and principles of measurement; that is, transactions are clear, transparent, verifiable, protect all consumers, and promote fair competition in the marketplace. This proposal is an opportunity for a uniform method of sale by mass units and is aligned with practices adhered to globally for this application. The proposal shown above might be made more palatable by including some corresponding NIST Handbook 130 language to address street price signage requirements; it is highly possible to develop, distribute, and vet a set of minimal modifications to HB 130 before July 2015, if deemed necessary.

**2015 NCWM Interim Meeting:**

NCWM 2015 Interim Meeting: The S&T and L&R Committees took comments on S&T Item 337-1 and L&R Items 232-4 and 237-1 collectively during a special joint open hearing session. There were two proposals offered for consideration concerning the appropriate method of sale (MOS) for natural gas and it was stated that comments would be taken on both to determine which proposal best represents the body of the NCWM. Proposal 1, titled “The Volume Equivalent Compromise Proposal” would require natural gas to be measured in mass and indicated in and sold by equivalent gallon units or mass. Proposal 2, titled “The Mass Compromise Proposal” would require natural gas to be measured and indicated in and sold by mass and supplemental equivalent information be displayed on the dispenser for value comparison only.

Comments in support of Proposal 1 were primarily heard from representatives of the gas industry, manufacturers of natural gas retail motor fuel dispensers, natural gas refueling station owners, fuel marketers, and other industry representatives. Two state weights and measures directors, Mr. Albuquerque and Mr. Joe Gomez (New Mexico), also

provided comments in support of Proposal 1. The following list includes the primary comments heard in support of Proposal 1 (this list is not all inclusive of every comment, but intended to capture the key points raised):

- Volume equivalent units recognize what’s already in the marketplace – acceptance would put all retailers on the same footing.
- The first proposal provides the best chance of having a national standard.
- The proposal was submitted because of LNG; not CNG. There is no MOS specified for LNG. LNG is a fuel that will mostly be used in trucks.
- The feedback we are hearing from our customers is that they want to make value comparisons using gallon equivalent units.
- We can build dispensers that measure in mass. Providing both indications (mass and equivalent gallons) would be very expensive to build. Our customers like gallon equivalents. It would create confusion if you put two values there. These are two different units of measurement; unlike cash/credit pricing.
- It would be considered an unfair trade practice to advertise on the street in one unit of measure and dispense product in another unit of measure. The advertised unit price should match the unit price on the dispenser.
- We want to hear feedback from our customers. They value the comparison of LNG to diesel because it is a quick and easy determination. We talk to our customers. They want to make comparisons by using DGE.
- Universally, our customers want, ask, and purchase in gallon equivalent units. We can provide an indication in mass units. Is it worth changing a twenty-year industry MOS to something industry doesn’t want? Our equipment measures in mass and indicates in gallon equivalents.
- Support gallon equivalent units for three reasons:
  1. uniformity:
  2. clarity in the marketplace (there have been no complaints...customers want it): and
  3. verification for fairness – both will be verified in mass (not BTU).

Comments heard in support of Proposal 2 were predominantly made by weights and measures officials. The following list includes the primary comments heard in support of Proposal 2 (This list also is not all inclusive of every comment, but intended to capture the key points raised.):

- We’re a standards organization. Equivalent units are not a standard. This is a marketing tool. Allowing equivalent units would provide industry a competitive advantage.
- Equipment is capable of providing mass indications.
- There is a general lack of support for DGE and GGE units among regulators.
- Label equivalent units on the front of the dispenser and measure and indicate in mass.
- Which method would provide the most value comparison to the customer? Many products offered for sale provide supplemental information. Examples given: fertilizer sold by weight provides square footage coverage information; paint sold by gallon provides spread dimensions, etc.
- Need to sell by a quantifiable measurement – mass.

- Proliferation of “equivalent units” is a real concern.
- There are questions concerning the validity of the equivalent values being proposed. Natural gas composition fluctuates, as does the composition of gasoline. How accurate are the numbers? We’re not comfortable that the study on BTU by the Energy Department provides accurate enough information. Industry reported specific gravities change by as much as 12 %.
- We stand to face the same mistake made 20 years ago. It was a mistake then and it would be a mistake now.
- There are new fuels coming onboard. The same argument can be made for equivalent units. How do you tell the next group “no”?
- Products need to be sold by a recognizable unit of measure.
- We are a standards organization – the best way to sell is the way it’s actually measured.
- Consumers have purchased propane by weight for years and years. They’ve never asked how much they were receiving in gallon equivalent units.
- We are not the world. There are not liter equivalent units in Canada, Europe, or Japan.
- Consumers learn what the measurement is and then they do the calculations. Consumers will know before they purchase a vehicle what their cost per mile will be.
- On January 1, 2015, a California law added DGE and GGE. It is a very bad law. I urge the Conference not to follow that course. Support the second proposal.

Mr. Constantine Cotsoradis (Flint Hills Resources) commented that he would be opposed to moving forward to satisfy the marketing of one industry. He noted that Flint Hills Resources sells LNG by weight using a truck scale to weigh it. If equivalent units were required, the weight would need to be converted to equivalent gallon units. He suggested that Proposal 1 be modified to apply to retail stations rather than retail sales. However, when the Committee announced after the Open Hearings that it had modified Proposal 1 to allow natural gas to be sold by equivalent gallon units or mass as shown in Item Under Consideration, Mr. Cotsoradis indicated his concern had been satisfied.

Following the Open Hearings, the S&T and L&R Committees met jointly in an open work session to decide which proposal would be presented to the NCWM for vote given the comments heard during the Open Hearings. Several members of the NGSC were in attendance and provided feedback during the meeting. In considering this issue, two or three members of the S&T and L&R Committees led a discussion in favor of putting forward Proposal 1 for Vote by emphasizing that proposal’s flexibility in allowing jurisdictions to make the decision on which MOS is appropriate. Mr. Richard Harshman, NIST Technical Advisor to the S&T Committee, acknowledged that during the Open Hearings, the comments heard from industry representatives overwhelmingly supported Proposal 1, but industry representatives are not permitted to vote. Mr. Harshman pointed out that during Sunday’s joint meeting of the NGSC, S&T, and L&R Committees, it was stated that the goal for this Interim Meeting was to select the proposal that best represents the body of, and, therefore, most likely to be adopted by the NCWM. He also provided a count of the number of weights and measures officials who commented in support of each proposal during the Open Hearings, noting that they represented the group that could vote. Officials commenting in support of Proposal 2 numbered five. Officials commenting in support of Proposal 1 numbered two. It was then stated by Mr. Louis Sakin (Town of Hopkinton/Northbridge, Massachusetts), a member of the L&R Committee, that this tally was not a true representation of all in the room who could vote and that many who could vote had not spoken during the Open Hearings. Mr. Sakin concluded that most of these “silent officials” (i.e., officials who did not provide testimony during the Open Hearings) would be in favor of Proposal 1. Some others in the room agreed and consequently, the two Committees voted in favor of putting forth Proposal 1 for a July vote by NCWM.

There were mixed positions amongst the S&T Committee members as to the method of sale, but overall the Committee, in conjunction with the L&R Committee, elected to put forth a version of Proposal 1 (volume equivalents)

and recommend a Voting status for this version. The S&T Committee's modification to Proposal 1 included deleting the words "if required by the weights and measures authority having jurisdiction" in Paragraphs S.1.3.1.1. and S.1.3.1.2. The Committee also agreed to reinsert the current NIST Handbook 44 definition of "gasoline liter equivalent" shown as completely struck out into the Item Under Consideration with the understanding that the intent of the NGSC is to eliminate all references to "GLE" from NIST Handbook 44. The Committee recognizes that "GLE" is referenced throughout the Mass Flow Meters Code and that these references are an issue still needing to be addressed. A final action agreed to by the Committee was to add the following option for marking supplemental information in Proposal 2 of the two proposals considered at the 2015 NCWM Interim Meeting:

**A Diesel Gallon Equivalent means 6.059 pounds (2.748 kg) of LNG.**

The Item Under Consideration includes the Committee's modification to the S&T portion of Proposal 1 and replaces the previous Item Under Consideration proposal that was voted on and returned to Committee during the 2014 NCWM Annual Meeting due to a split vote.

**2015 NCWM Annual Meeting:**

NCWM 2015 Annual Meeting: The S&T and L&R Committees took comments on S&T Item 337-1 and L&R Items 232-4 and 237-1, collectively, during a special joint open hearing session. There were comments in both support of and opposition to the proposal. Multiple people provided oral comments and Mr. Mahesh Albuquerque (Colorado), Chairman of the S&T Committee, reported that there were over 10 letters in support of the proposal, which had been posted on NCWM's website. Much of the testimony, whether it be in support or opposition, were iterations of points that had been made in previous NCWM Conference Meetings beginning from the time this item first appeared on the Committee's Agenda.

The following are some examples of comments heard in support of the proposal:

- Equivalent units have been used since 1994 without issue. We can't undo what was accepted over 20 years ago.
- Equivalent units are what customers and fuel retailers desire.
- Users of natural gas are truckers and the American truckers, as well as the retailers, are on board with respect to the current proposal.
- Equivalent units are necessary for taxation purposes (it was reported that 26 states currently have adopted a DGE standard for taxation and 10 states recognize DGE as a method of sale).
- Equivalent units provide value comparison with gasoline and diesel.
- Dispensers indicating in mass units and street sign advertising indicating in volume equivalent units would conflict with some laws requiring both units be identical.
- The country needs a single standard.
- Volume equivalent values are derived from mass units. Testing will be in mass units and everyone will be using the same factor to compute mass units to a volume equivalent values.

The following are some examples of comments heard in opposition of the proposal:

- A mistake was made in 1994 allowing volume equivalent values in the marketplace for CNG. Proliferation of "equivalent units" is a real concern. When a mistake is made, it should be fixed, not allowed to continue.
- Volume equivalent units are not clear and transparent to the consumer.

- Volume equivalent units are not traceable units.
- Under the current proposal, fuel retailers may sell by volume equivalent units in one location and mass units in another (or even in another state) lending to inequity in the marketplace for businesses and confusion for consumers.
- If gallon equivalents are necessary for taxation, then the taxation agencies can use the values they deem necessary to approximate the indicated mass values to gallon equivalents.
- Customers will have already researched the value of natural gas during their decision-making process *before* purchasing a natural gas powered vehicle. Thus, they will not need to make ongoing comparisons to other types of fuel when making purchases of natural gas.
- Customers will calculate the cost per mile of operation of a natural gas powered vehicle versus a gasoline or diesel powered vehicle, thus, the need to attempt direct comparison of natural gas sold by mass to gasoline or diesel gallon equivalents is not needed.
- Natural gas being sold by mass vs. by gasoline or diesel gallon equivalents is attempting to compare “apples to oranges.”

Ms. Tina Butcher (NIST, OWM) provided an overview of OWM’s analysis of the current proposal and explained that a more complete analysis had been provided in writing to the Committee. A copy of OWM’s complete written analysis of this item is included in Appendix G of this report.

It was also reported during the special joint open hearing that there is currently a pending legislative item before the U.S. Congress specifying a slightly different conversion factor for DGE (6.06 lb) than that contained in the Item Under Consideration (6.059 lb), essentially rounding off to two significant digits after the decimal point instead of three. Voting on the legislation is pending, awaiting the outcome of the action taken by NCWM at this Annual Conference on adopting a conversion factor. In response to this reported information, Mr. Ron Hayes (Missouri), Chairman of the Natural Gas Steering Committee (NGSC), stated that we shouldn’t be selecting a number just because there are bills out there using another number. He reported that the NGSC could not reach consensus on a conversion factor for DGE because no data could be found that supports any factor. He further noted gasoline has a variation in energy content. Diesel, too, varies. The hard part then becomes selecting the right number (conversion factor). If we were selling gasoline and diesel fuel by mass, energy content is consistent; this is not the case on a gallon basis.

During the Committee’s work session, several Committee members acknowledged the comments heard were both in favor of and in opposition to the proposal and many of those comments were the same as those heard in previous open hearing sessions. The Committee agreed to recommend the item be presented for Vote unchanged.

#### **Regional Association Meetings:**

**CWMA 2014 Interim Meeting:** The CWMA reported that a segment of the industry supports this item. The majority of the regulatory body does not support the item as written. Based on the comments received, the CWMA recommended that the item be an Informational item. The CWMA also recommends that the commodity shall be measured in mass units and indicated in mass units. Equivalency units may be included as supplemental information. At the 2015 CWMA Annual Meeting, the following comments were received during a joint session of the CWMA L&R and S&T Committees:

It was recommended that comments for this item along with CWMA L&R Items 237-1 and CWMA S&T Item 337-1 be heard together. A state regulator from Missouri commented that Item 237-1 should be considered separately. Item 237-1 focuses on language relevant to the Method of Sale section, so it should be removed from the bundle of three items and considered separately. An industry representative from National Association of Convenience Stores and the Society of Independent Gasoline Marketers of America (NACS-SIGMA) rose in support of marketing and selling natural gas as a road fuel by equivalency, but be measured for accuracy by mass that would be posted on the dispenser along with a voluntary marketing statement, which includes the equivalency price. He stated the objective of the Conference is equity in the

market, which fundamentally means consumers get what they bargain for in a transaction. He also believes it is essential that we get products to the market in terms people understand. Retailers stock and sell what consumers want to buy – not the other way around. So, customers for compressed natural gas have approached the fuel retailers and have expressed a desire to purchase their product in diesel gallon equivalencies. He commented that no one wants to buy “pounds” of natural gas. He believes some fleets prefer purchasing in diesel gallon equivalencies. He asked why we should we sell a product in a language that consumers don’t understand, even if over time they will understand it. He encouraged the Conference to consider allowing diesel gallon equivalency as a method of sale for both compressed and liquid natural gas. He is concerned that our inability to come up with a preferred method of sale is an obstacle to selling this fuel. He further commented that in actual terms, all weights and measures are arbitrary. By not adopting this proposal, regulators will fail in their objective to provide equity in the market. If they do not pass it, a different body will set standards. A regulator from Missouri and also a member of the Natural Gas Steering Committee commented that the Committee proposed two items – one was to sell natural gas on a volumetric method; the second (considered a compromise) is to market or advertise the products in equivalency values, but measure for compliance using mass, and display that value on dispensers. Nothing would preclude a retailer from displaying a gallon equivalency value on an advertising sign as long as the mass weight is posted on the dispenser along with that equivalency value. He further commented that he is opposed to selling in diesel gallon equivalents. He said natural gas equivalencies will vary so much for every diesel vehicle that the equivalency information will be more misleading than informative. He provided several examples of this. He concluded his comments by saying the Conference made a mistake by establishing the gasoline gallon equivalent method of sale twenty years ago, but that should not be a precedent to make another mistake by passing an equivalency value again. The industry representative commented that all states should check in with their states’ attorneys general, because he believes if an advertising sign posts an equivalency amount, it has to be posted that way on the dispenser – otherwise it is a deceptive practice. An industry representative from Flint Hills Resources commented that they sell LNG in bulk to the end user, so it is considered a retail sale. He supports the compromise the Natural Gas Steering Committee came up with, which would allow for the posting of an equivalency value, but would also require the product be measured by mass. With the compromise, jurisdictions can decide for themselves if they want to post equivalencies or if they want to sell by mass. A regulator from Minnesota has changed her mind from supporting sales strictly in mass to support sales by equivalence.

Primarily for taxing considerations, state officials and policy makers in her state want the Conference to provide a measurement in mass, pick an equivalency number for diesel gallons, and standardize the process. A second regulator from Missouri commented that a taxing unit is different from weights and measures work. He believes that the science of weights and measures is absolute, and there should be no exceptions. The NACS-SIGMA representative again commented that states are currently developing a patchwork of policies addressing this issue because there is no standard in place today, and if the Conference does not pass a standard, Congress will take the decision out of the hands of the Conference, because people who market natural gas nationally won’t want to deal with a patchwork of varying policies and procedures. A regulator from Kansas expressed a concern that a DGE and a GGE price per gallon equivalency at the same station could result in a different price per pound, which would result in confusion for the consumer. The first Missouri regulator rose to remind the Conference that if this proposal fails, GGE does not go away. Currently, LNG is being taxed at the diesel rate calculated on a mass basis. A state regulator from Iowa asked for clarity as to whether there was a method of sale in NIST Handbook 130 based on weight for compressed natural gas. There is a method of sale for CNG based on GGE. A NIST representative commented that she thought this proposal addresses a method of sale for LNG. An industry representative from Gilbarco indicated their natural gas customers are requesting GGE’s and DGE’s. They already measure in mass and make the conversion. However, Gilbarco cannot serve the needs of their customers because they cannot sell an NTEP certified device reflecting these equivalency values. He commented that no one is asking for a display in mass, nor for a dual display. He supports the diesel gallon equivalency method for natural gas sales. The Minnesota regulator commented that they have a current scenario where a retailer in their state needs an NTEP certified device, and they are not yet available. A Missouri regulator asked if Gilbarco were displaying the sale price of natural gas in pounds, and their customers made a request to see it in an equivalency mode, would they respond to their customer’s request. The Gilbarco individual answered that if their customer wants supplemental labeling, it would be possible. Beyond that he cannot predict what is possible or likely, but there currently are no plans to develop dual-display devices to his knowledge. The



NACS-SIGMA representative commented again that dispenser manufacturers are working on other issues beyond this one.

This item was presented for a Vote during the L&R voting session and passed by a margin of one vote. The CWMA recommended this item move forward as a Voting item.

WWMA 2014 Annual Meeting: During the Open Hearings, an update on the NGSC was provided and comments were heard (pro and con) for this item, similar to what has been offered previously. The WWMA agrees that this topic needs to be addressed and resolved; therefore, it should remain as an Information item on the NCWM Agenda. The WWMA S&T Committee offers the recommendations of: 1) consideration of the NIST Proposal; 2) possibility of a customer selectable unit; and 3) determination of GGE to low-volume sales and DGE to high-volume sales. During the S&T Committee voting session, it was motioned, seconded, and approved that comments presented during the L&R Committee voting session be adopted. The comments included a call for Vote by those in support of sale in mass versus those in support of sale by equivalent unit. A show of hands was recorded by the Parliamentarian and indicated those in favor of mass to be 23 and those in favor of equivalent unit to be 12.

SWMA 2014 Annual Meeting: The SWMA recommended deferring to the NGSC which will provide recommendations at the 2015 NCWM Interim Meeting.

NEWMA 2014 Interim Meeting: NEWMA recommended that NEWMA S&T Items 337-1 and 232-3 and NEWMA L&R Item 237-1 remain Information items pending final language from the NGSC at the NCWM 2015 Interim Meeting. It was further recommended that the NGSC consider changing the method of sale to mass and that the NIST proposal to modify Section 3.37. Mass Flow Meters in NIST Handbook 44 (2014 edition) be considered. It was noted that the draft NIST proposal was posted on the NEWMA website as a supporting document. At the 2015 NEWMA Annual Meeting, this item was grouped with L&R Agenda Items 237-1 and 237-3. There were comments heard in both support of and opposition to these items as follows:

A Maine official reported that the State of Maine believes mass is the appropriate unit of measure for this product. Maine will not support any proposal with an equivalency measure because it is not a traceable unit. A county official from New York asked how many states had proposed or accepted new laws with equivalencies. NGSC Chair Mr. Ethan Bogren (Westchester County Weights and Measures), in response to the question, indicated there were six states that had adopted equivalency language or something similar. Several other states were also moving in that direction. A retired official from New York suggested reviewing the model law of Uniform Weights and Measures – while directors can determine and issue regulations regarding method of sale, it is not the directors who should initiate the unit of measure. Buyers and sellers should determine the unit for the method of sale. He stated that he believes the weights and measures community has an obligation to listen to the stakeholders, who have made it clear they want equivalency units.

The NEWMA S&T Committee's recommendation to the region was that S&T Agenda Item 337-1 be a Voting item on the NCWM's Agenda. A motion was made to accept this recommendation, but not seconded; therefore, the item was returned to the Committee.

Additional letters, presentations, and data may have been part of the Committee's consideration. To review the supporting documentation, please refer to the *Report of the 99<sup>th</sup> National Conference on Weights and Measures* (SP1193, 2014).

**337-2 W S.3.6. Automatic Density Compensation.**

(This item was Withdrawn.)

**Source:**

NCWM Natural Gas Steering Committee (NGSC) (2014 Interim Meeting)

This is a new item (2014) that originated from the NCWM NGSC as a result of its deliberations January through March 2014 on Agenda Item 337-1 (an alternative proposal for defining and establishing legal metrology requirements for quantity indications and markings on a device when CNG and LNG are dispensed and sold as engine fuel in volume equivalent units). The NGSC recommended the proposal as a Developing item to allow additional time for the NCWM NTEP Measuring Sector and Measuring Laboratories to fully vet the proposed modifications to NIST Handbook 44, Mass Flow Meters Code Paragraph S.3.6. Automatic Density Correction.

**Purpose:**

Provide a starting point for work identified in March 2014 by the NGSC and the S&T Committee that is necessary to fully address legal metrology requirements for LNG retail and wholesale applications.

**Item Under Consideration:**

Amend NIST Handbook 44, 3.37. Mass Flow Meters Code Paragraph S.3.6. as follows:

**S.3.6. Automatic Density Correction.**

- (a) An automatic means to determine and correct for changes in product density shall be incorporated in any mass flow metering system that is affected by changes in the density of the product being measured.
- (b) Volume-measuring devices with automatic temperature compensation used to measure **liquefied** natural gas as a motor vehicle engine fuel shall be equipped with an automatic means to determine and correct for changes in product density due to changes in the temperature, ~~pressure, and composition~~ of the product.

(Amended 1994 ~~and~~ 1997, and 20XX)

**Background/Discussion:**

After the January 2014 NCWM Interim Meeting, the NGSC and the S&T Committee received input from Mr. Dmitri Karimov (Liquid Controls Corporation, LLC and a member of the NGSC), who proposed to differentiate between CNG and LNG in the requirements of paragraph S.3.6 “Automatic Density Correction” when using volumetric devices. Mr. Karimov indicated that density calculations of LNG when measured using a volumetric device, require temperature determination only. CNG devices will not be allowed to use indirect mass measurement in Mr. Karimov’s proposal.

Mr. Karimov provided the NGSC and S&T Committee with the following points as rationale for the proposed changes to paragraph S.3.6.:

- The requirements for volume-measuring devices were developed in 1994 and 1997 for CNG based on Hydrocarbon Gas Vapor-Measuring Devices Code. (See the NCWM final reports from those years for additional details.)
- The concerns might be valid for CNG, but not for LNG. For LNG, only a temperature input is required to calculate a mass value.
- Based on the most recent changes to the Mass Flow Meters Code by the NGSC, indirect mass measurement is proposed to be allowed for LNG, but not CNG; so, S.3.6. needs to be modified.
- CNG and LNG mass flow meters (Coriolis) with automatic density correction will be covered by paragraph S.3.6.(a)
- LNG volume-measuring devices (such as orifice plate and turbine meters) will be covered by paragraph S.3.6.(b) since indirect mass measurement for CNG is no longer allowed under the proposal by the NGSC.

- CNG (being gas) is very compressible, so pressure is a significant influence factor in density calculations. “Pressure” was added to S.3.6.(b) in 1997 because, at that time, the paragraph was relied upon only for CNG.
- On the other hand, LNG is measured at very low pressure and, being liquid, is not compressible at the pressures at which it is measured. The pressure effect on density of LNG is therefore negligible. See the table below where Mr. Karimov generated data on LNG density changes using the NIST REFPROP database.
- Per documentation received by the NGSC from the Clean Vehicle Education Foundation, the composition of natural gas remained virtually unchanged over the last 21 years. Therefore, volumetric devices for LNG could use fixed composition in density calculations as per ASTM D4784 Clause 2.1 (see below).
- Finally, indirect mass measurement volumetric devices undergo type evaluation, and only those devices meeting accuracy requirements through proper density calculations are approved.

#### Supporting documentation:

**ASTM D4784 – 93 (Reapproved 2010) Standard Specification for LNG Density Calculation Models**  
ASTM D4784 provides models for density calculation.

#### 2. Significance and Use

**2.1 The models in this specification can be used to calculate the density of saturated liquid natural gas in the temperature range 90 to 120 K. The estimated uncertainty for the density calculations is  $\pm 0.1$  %. The restrictions on composition of the liquefied natural gas are:**

<b>methane</b>	<b>60 % or greater</b>
<b>nitrogen</b>	<b>less than 4 %</b>
<b><i>n</i>-butane</b>	<b>less than 4 %</b>
<b><i>i</i>-butane</b>	<b>less than 4 %</b>
<b>pentanes</b>	<b>less than 2 %</b>

Mr. Karimov also referenced excerpts from past NCWM Final Reports from 1994 and 1997; see those reports for additional details.

Listed below is the table Mr. Karimov generated on LNG density changes using the NIST REFPROP database. Mr. Karimov noted that density changes to LNG are negligible at 120 K with changes in pressure from the base pressure of 27.765 psi up to 200 psi.

<b>Density Changes to LNG</b>			
<b>Temperature<sup>1</sup> (K)</b>	<b>Pressure (psia)</b>	<b>Density (lb<sub>MASS</sub>/gal)</b>	<b>% Density Difference<sup>2</sup></b>
120	27.765	3.4208	0.000%
120	30	3.4209	– 0.003%
120	35	3.4213	– 0.015%
120	40	3.4216	– 0.023%
120	45	3.4219	– 0.032%
120	50	3.4222	– 0.041%
120	55	3.4225	– 0.050%

Density Changes to LNG			
Temperature <sup>1</sup> (K)	Pressure (psia)	Density (lb <sub>MASS</sub> /gal)	% Density Difference <sup>2</sup>
120	60	3.4229	- 0.061%
120	65	3.4232	- 0.070%
120	70	3.4235	- 0.079%
120	75	3.4238	- 0.088%
120	80	3.4241	- 0.096%
120	85	3.4245	- 0.108%
120	90	3.4248	- 0.117%
120	95	3.4251	- 0.126%
120	100	3.4254	- 0.134%
120	105	3.4257	- 0.143%
120	110	3.4261	- 0.155%
120	115	3.4264	- 0.164%
120	120	3.4267	- 0.172%
120	125	3.427	- 0.181%
120	130	3.4273	- 0.190%
120	135	3.4276	- 0.199%
120	140	3.428	- 0.210%
120	145	3.4283	- 0.219%
120	150	3.4286	- 0.228%
120	155	3.4289	- 0.237%
120	160	3.4292	- 0.246%
120	165	3.4295	- 0.254%
120	170	3.4298	- 0.263%
120	175	3.4302	- 0.275%
120	180	3.4305	- 0.284%
120	185	3.4308	- 0.292%
120	190	3.4311	- 0.301%
120	195	3.4314	- 0.310%
120	200	3.4317	- 0.319%
<sup>1</sup> 120 K (- 153 °C) (- 243 °F)			

Density Changes to LNG			
Temperature <sup>1</sup> (K)	Pressure (psia)	Density (lb <sub>MASS</sub> /gal)	% Density Difference <sup>2</sup>
<sup>2</sup> Percent difference in product (pure methane) density is based on calculated variations to the base pressure of 27.765 psi using NIST REFPROP			

Initially Mr. Karimov presented his proposal to his colleagues on the NGSC. During the NGSC's deliberation on the Clean Vehicle Education Foundation's proposed changes to other Mass Flow Meters Code paragraphs (see Agenda Item 337-1), the NGSC also considered Mr. Karimov's proposal. The NGSC agreed to encourage further work beyond the current scope of their work on the Clean Vehicle Education Foundation's proposals. Admittedly, many of the NGSC members indicated not fully comprehending the technical rationale for the Mr. Karimov's proposal. After discussions with the S&T Committee, both Committees agreed that the proposal should be vetted by the NCWM NTEP Measuring Sector and Measuring Laboratories to ensure the community understands the intent and impact of the proposed changes to paragraph S.3.6. Additionally, NIST, OWM plans to consult with its Cryogenics Group on the proposal. Based on its discussion with the S&T Committee, both Committees believe the proposal has merit and should be included in the S&T Committee's Interim Meeting report as a separate new item with Developing status.

#### 2014 NCWM Annual Meeting:

NCWM 2014 Annual Meeting: At the Annual Meeting there were numerous comments suggesting the proposal remain in a Developing status. Consequently, the Committee agreed to recommend this item remain Developing.

#### 2015 NCWM Interim Meeting:

NCWM 2015 Interim Meeting: The Committee agreed to Withdraw this item from its agenda at the request of the item's submitter.

#### Regional Association Meetings:

CWMA 2014 Interim Meeting: The CWMA did not receive comments on this item and recommended that it be an Information item.

WWMA 2014 Annual Meeting: During the Open Hearings a member of the NGSC offered testimony that the submitter requested this item be Withdrawn. WWMA agreed to recommend this item be Withdrawn.

SWMA 2014 Annual Meeting: The SWMA recommended this item to be Withdrawn from the agenda at the request of the submitter.

NEWMA 2014 Interim Meeting: NEWMA recommended that this item remain Developing. It was noted that further clarification is needed as to the intent to move forward with this item from the submitter.

Additional letters, presentations and data may have been part of the Committee's consideration. Please refer to <http://www.ncwm.net/meetings/interim/publication> to review these documents.

### 337-3 D N.3. Test Drafts.

#### Source:

Endress + Hauser Flowtec AG USA (2015)

#### Purpose:

Allow transfer standard meters to be used to test and place into service dispensers and delivery system flow meters.

#### Item Under Consideration:

Amend NIST Handbook 44 Mass Flow Meters Code as follows:

### N.3. Test Drafts.

**N.3.1. Minimum Test** – Test drafts should be equal to at least the amount delivered by the device in one minute at its normal discharge rate.

(Amended 1982)

**N.3.2. Transfer Standard Test. – When comparing a meter with a calibrated transfer standard, the test draft shall be equal to at least the amount delivered by the device in two minutes at its maximum discharge rate.**

#### **Background/Discussion:**

The use of transfer standards is recognized in the following NIST Handbook 44, Sections 3.34. Cryogenic Liquid-Measuring Devices Code; 3.38. Carbon Dioxide Liquid-Measuring Devices Code; and 3.39. Hydrogen Gas-Measuring Devices – Tentative Code. Field evaluation of LPG meters and CNG dispensers and LNG dispensers is very difficult using volumetric and gravimetric field standards and methods. The tolerances for these applications are such that using transfer meter standards are more efficient and safer. With CNG, LNG, and LPG applications, transfer standard meters are placed in-line with the delivery system as it is used to fill tanks and vehicles. The use of transfer standards eliminates return to storage issues. The use of transfer standard meters is easier and faster compared to the use of traditional field standards. The cost of using transfer standards and transporting them is much less than the cost of traditional field provers and standards. The submitter believes that recognition in NIST Handbook 44 will enable states to allow transfer standard meters to place systems into service and for field enforcement.

Volumetric field provers and gravimetric field proving are susceptible to environmental influences. The State of Colorado uses a master meter to test propane delivery truck meters. The State of Nebraska has used a mass flow meter to test agricultural chemical meters.

In some applications, transfer standard meters are not more accurate than the meters used in the dispenser. For that reason, longer test drafts and possibly more tests need to be run.

The State of California is purported to have conducted a short study of master meters in the past. The conclusion did not lead to wide adoption of the practice. However, the State of California uses a mass flow meter as a master meter for carbon dioxide flowmeter enforcement.

Mass Flow Meters Code paragraph U.R.3.8. Return of Product to Storage, Retail Compressed Natural Gas Dispensers requires that the natural gas, which is delivered into the test container, must be returned to storage. This is difficult and most often not complied with when the test vessel contents are released to atmosphere. *[Technical Advisor's Note: Paragraph UR.3.8. also provides the option to the device owner or operator to otherwise safely dispose of the product. See Paragraph UR.3.8. for details.]*

The S&T Committee might also consider amending Sections 3.30. Liquid-Measuring Devices Code and 3.31. Vehicle-Tank Meters Code to allow transfer standard meters.

#### **2015 NCWM Interim Meeting:**

NCWM 2015 Interim Meeting: The Committee agreed to group together Agenda Items 330-2 and 337-3 since these items are related and announced that comments on both items would be taken together during the Open Hearings. Refer to Agenda Item 330-2 for a summary of the comments heard concerning these two items. The Committee agreed this item has merit and recommends the submitter of these items work with OWM by providing data for the NIST USNWG on Alternative Test Methods to consider in determining the suitability of the master meter transfer standard as a standard in testing another device.

#### **2015 NCWM Annual Meeting:**

NCWM 2015 Annual Meeting: The Committee agreed to group together Agenda Items 332-2 and 337-3 and take comments on the two items simultaneously. See Agenda Item 332-1 for a summary of comments heard on these two items. In consideration of the comments heard in support of the two agenda items, the Committee agreed to maintain the Developing status of both items.

**Regional Association Meetings:**

CWMA 2014 Interim Meeting: The CWMA received comments questioning the accuracy of a meter used as a mobile standard. The CWMA forwarded the item to the NCWM, recommending it as a Developing item. At the 2015 CWMA Annual Meeting Open Hearings, Mr. Robert Murnane (Seraphin Test Measure Co.) questioned the validity of transfer standards and the purpose of this item. He also stated that he believed the item was too general in scope. CWMA agreed to recommend this item move forward as a Developing item noting it supported the item's continued development.

WWMA 2014 Annual Meeting: Testimony was presented that this type of technology would more easily facilitate inspections. However, it was also stated that a more comprehensive evaluation of the equipment and testing procedure, including associated uncertainties, be performed. The WWMA agreed that this type of technology would be useful, but it should be a Developing item to enable the submitter to provide a more complete analysis.

SWMA 2014 Annual Meeting: The SWMA heard questions and concerns that needed to be addressed by the submitter. The SWMA also recommended that NIST, OWM continue to develop a standard for this equipment to development standards and other guidance documents necessary to recognize their use. Additionally, the SWMA recommended the submitter work with NIST, OWM to address these concerns. The SWMA recommended that Items 332-2 and 337-3 be combined into one agenda item since they are both related to test drafts. Comments were heard for both of these agenda items at the same time.

NEWMA 2014 Interim Meeting: NEWMA reported at its that it believed his item has merit but needs further vetting and development before being sent to a Vote. NEWMA forwarded the item to the NCWM and recommended that it be a Developing item. NEWMA also recommended this item be combined with Items 332-2 and 337-3 as a single agenda item. At the 2015 NEWMA Annual Meeting, a recommendation was made to Withdraw this item with the intent that it be resubmitted once clarification has been provided regarding the accuracy of the transfer standard meters. However, at the recommendation of NEWMA's S&T Committee, NEWMA agreed to leave this item Developing while work continues on the proposal.

Additional letters, presentations, and data may have been part of the Committee's consideration. To review the supporting documentation, please refer to the *Report of the 99<sup>th</sup> National Conference on Weights and Measures* (SP1193, 2014).

**354 TAXIMETERS**

**354-1 V S.1.1.1. Recording Elements.**

(This item was Adopted.)

**Source:**

NIST USNWG on Taximeters (2015)

**Purpose:**

Ensure that customers can receive a printed receipt detailing charges for taximeters put in service after a specified date.

**Item Under Consideration:**

Amend NIST Handbook 44, 5.54. Taximeter Code as follows:

**S.1.1. General.** – A taximeter shall be equipped with a primary indicating element ~~and may be equipped with a recording element.~~  
(Amended 1988 and 2015)

**S.1.1.1. Recording Elements. – A receipt providing information as required in S.1.9. Recorded Representations shall be available from a taximeter or taximeter system through an integral or separate recording element for all transactions conducted.**

**[Nonretroactive January 1, 2016]**

**(Added 2015)**

**Background/Discussion:**

Transactions involving “for-hire” vehicles may include multiple charges and, as a result, be somewhat complex. Total charges resulting from taxi services in some jurisdictions can include the fare based on time and distance traveled as well as extras and other additional charges. Those extras and additional charges may include charges for additional passengers, transportation of luggage, tolls, surcharges, and taxes. In some locations, passenger(s) are presented with offers for other services unrelated to the taxi service during the trip, such as the purchase of tickets for theater shows or other events. If purchased, the cost of these services may be included as part of the overall charge in the transaction.

The USNWG on Taximeters has noted that, in many instances, the interchange between passenger and the taxi driver is brief and the passenger may not immediately comprehend fully all the details regarding a transaction. With a potential total cost to the passenger comprised of numerous charges, it is considered important that the customer (passenger) be able to receive a record of those charges as evidence of what was paid for. Requiring that a form of receipt (printed or electronic) be made available to the passenger when desired, will help to ensure that the customer is provided a record of expenses paid for and as necessary documentation in cases where charges may be disputed.

Amending paragraph S.1.1. as shown will remove the existing *optional* provision for a recording element associated with a taximeter and the addition of a new S.1.1.1. will require a form of receipt capable of being produced by the taximeter system for all transactions (non-retroactively). Taximeter systems manufactured and placed in service prior to the effective date of the new paragraph S.1.1.1. will still be permitted and will not be required to include a recording element; however, those manufactured and placed into service after the effective date will be required to make a receipt available to the customer. It is intended that the non-retroactive status will provide device manufacturers ample time to comply with the proposed requirement.

Requiring receipts from all taximeters may be considered onerous to taxi owners/operators that operate in areas that have very simple rate structures and where the total charges to the customer would possibly only include a fare based on distance and/or time. This burden will be mitigated, however, by the non-retroactive status of the proposed new requirement.

**2015 NCWM Interim Meeting**

NCWM 2015 Interim Meeting: The Committee agreed to group together all of the “354” Taximeter Items (i.e., Agenda Items 354-1 through 354-6, inclusive) since it considered these items related and announced that comments on all six items would be taken together during the Open Hearings.

Ms. Tina Butcher (NIST, OWM) noted that Taximeter Items 354-1 through 354-5, inclusive, were submitted by the USNWG on Taximeters to address the emergence of new technology associated with taximeters by amending some current requirements and developing new requirements where needed. Because they are related, NIST, OWM agrees with the regional associations that these items could be combined into a single Voting item. Ms. Butcher also summarized the following update concerning Item 354-6, which was provided to the Committee in NIST, OWM’s analysis of the item:

**Update from the NIST Technical Advisor to the USNWG on Taximeters:**

During the same time period that the USNWG on Taximeters was being formed, reports from regulatory officials in the United States were being received that described transportation-for-hire services using cellular telephone software applications (“apps”) in conjunction with global positioning satellite (GPS) service to calculate fare charges for their passengers. The USNWG, which had been formed to update NIST Handbook 44, Taximeters Code in response to advances in taximeter design and operation, agreed also to include in the NIST Handbook 44 update the use of GPS service as a commercial source of time and distance measurement in conjunction with the use of cellular telephone apps.



Since the use of GPS in a commercial type of application had not been addressed previously, there were numerous technical and practical issues to be considered in the development of standards and regulatory policies. This was the motivation for the formation of a Subcommittee from within the USN WG that would focus specifically on the use of “smart-phone” apps and GPS. This GPS Subcommittee would be responsible for analyzing the many issues involved with the use of these technologies in a legal metrology context and report their conclusions to the USN WG on Taximeters. The USN WG would then assemble the data from the GPS Subcommittee to develop possible changes to NIST Handbook 44 that would allow the existing NIST Handbook 44, Taximeters Code to be applied to GPS-based services or possibly to conclude that the use of GPS in this manner would best be regulated under a separate NIST Handbook 44 code.

Very shortly after the formation of the GPS Subcommittee, the Chair position of that Subcommittee was vacated. The loss of the Chair created a situation where the work of the Subcommittee was suspended indefinitely due to the loss of that leadership role. The GPS Subcommittee was dormant for an extended period until NIST, OWM was able to fill the Chair position again. This position was filled in September 2014 with a NIST contractor.

On November 20, 2014, the GPS Subcommittee met via web-conference to revive its efforts. Since this meeting included some changes in the subcommittee’s membership roster, the focus of the meeting was to establish the scope and the mission of the Subcommittee and to provide an orientation for new members. Subsequent meetings are being planned and are expected to be held at regular intervals (every two to three months) in the form of web-conferences, teleconferences, or simply through e-mail exchanges among the members. A report to the USN WG on Taximeters will be made by the GPS Subcommittee following the Subcommittee meetings and whenever significant conclusions or revelations are made that will impact the efforts of the USN WG.

Mr. James Cassidy (Cambridge, Massachusetts), a member of the USN WG on Taximeters, stated he supported the proposals (Items 354-1 through 354-5) moving forward as Voting items.

Mr. Ross Andersen (New York, Retired) expressed concern regarding use of the term “Advancement of Indicating Elements” in Agenda Item 354-2 as it applies to “flat rate” fares. He noted that when a fare is based on a flat rate, there is no advancement of the indicating elements as there is with the measurements associated with time and distance. For this reason, it would be inappropriate to address charges associated with a flat rate fare in Paragraph S.1.2. Advancement of Indicating Elements. With regard to Item 354-5, he reported that in the State of New York there are unregulated taxis that are not equipped with ticket printers. These taxis simply charge a “fare” and “extras.” A New York ordinance allows for this (i.e., to operate with no ticket printer and charges based on a “fare” with “extras” added).

With respect to Item 354-6, Ms. Kristin Macey (California) urged the USN WG to develop a new code to address GPS-based systems if it’s determined that requirements applicable to these systems can’t be inserted into the existing NIST Handbook 44, Taximeters Code. She also requested the USN WG not prevent these systems from calculating fare on time and distance at the same time. She reported that California is currently evaluating software provided by the company, “Lyft.”

Mr. Jim Truex (NTEP) noted that there may be an issue concerning the effective date of nonretroactive requirements. The issue has to do with basing the application of nonretroactive requirements on the date of manufacture **or** the date of NTEP certification and may necessitate a change to G-A.6. Nonretroactive Requirements.

With respect to this particular Item 354-1, the Committee agreed to assign the effective enforcement date of January 1, 2016, to the proposed new paragraph S.1.1.1. Recording Elements and recommend the item for Vote at the July NCWM Annual Meeting.

**2015 NCWM Annual Meeting:**

NCWM 2015 Annual Meeting: The Committee agreed to group together Agenda Items 354-1 through 354-5 and 360-3 and take comments simultaneously on these six items.

Ms. Tina Butcher (NIST, OWM) reported that the USNWG on taximeters is requesting Items 354-1 and 354-2 be downgraded to an Informational status due to concerns raised regarding these two items at NEWMA's May 2015 Annual Meeting. She noted that following the NEWMA Meeting, the WG considered various options for revising the two proposals and believes any revisions to sufficiently mitigate those concerns would require more than minor editorial changes. NIST, OWM believes the change in status is appropriate and would allow time for additional work by the USNWG. Ms. Butcher also noted that the NIST Handbook 44 code reference currently appearing beneath the definition of "point-of-sale" in Appendix D of NIST Handbook 44 is missing from the definition shown in Item Under Consideration for Agenda Item 360-3 and needs to be added to the proposal.

Mr. Russ Vires (Mettler-Toledo, LLC) speaking on behalf of the SMA reported that the SMA supports Agenda Item 360-3.

Mr. Ross Andersen provided the following comments in opposition to Agenda Item 354-1:

- The concept of requiring a printed receipt for every transaction is a major step and many NIST Handbook 44 codes do not require there to be a printed receipt. One code that does require a printed receipt is the Vehicle-Tank Meters (VTM) Code; the reason being, in 95 % of the cases, the buyer is not present to witness the delivery transaction. This is not the case with taximeters; one hundred percent of the time, the customer is present to witness the transaction.
- In some cases, involving taximeters, weights and measures officials share regulatory authority with a taxi commission. The local taxi commission needs to address this concern; not weights and measures. The requirement to issue a receipt should be a user requirement legislated by the taxi commission.

Mr. Mike Sikula (New York) stated that he supported the recommendation of the USNWG to downgrade Agenda Items 354-1 and 354-2 to Informational items.

Mr. John Barton (NIST, OWM), Technical Advisor to the USNWG on Taximeters, reported that the USNWG recognizes that printers are not required under NIST Handbook 44 standards yet, but noted that taxi displays in general provide very limited information; for example, no display of measured mileage, charge per mile, etc. Typically, the information displayed by the taximeter is limited to the accrued monetary charge and an average passenger is not able to determine if those charges have been applied correctly.

Ms. Joanne Rausen (New York City Taxi and Limousine Commission) agreed with Mr. Barton and expanded on his comments by stating in an age of transparency this information, as a baseline, is needed. Rates applied for taxi services vary widely from one jurisdiction to another. Therefore, it is unlikely that a passenger visiting an unfamiliar area would be knowledgeable about the rates being applied. Additionally, providing a receipt to the passenger would give them the documentation needed to seek recourse if details of a transaction were to be questioned. Because crucial transaction details are not normally displayed on the taximeter, that information should be available by providing it on a receipt.

One official, commenting in support of the items, indicated receipts are needed for reimbursement of travel expenses. Another official commented that she supported the block of items as written.

During the Committee's work session, members of the Committee considered whether or not to downgrade Agenda Items 354-1 and 354-2 as recommended by the USNWG. Several members of the Committee stated they believed these items had been sufficiently developed by the USNWG, were being recommended for Vote by the USNWG, and that ample opportunity had been provided by the USNWG to provide input into the development of these proposals. They viewed the concerns being raised by one state as "last minute" issues should have been addressed well before the NCWM Annual Meeting. Members noted that the comments heard during the Open Hearings suggested the USNWG still supported these two proposals as written. Consequently, the Committee agreed to recommend the two items be presented for Vote, but agreed to exclude them from the Voting Consent calendar to allow them to be voted on as stand-alone items.

During the voting session, when asked if there were any comments on Agenda Item 354-1, Mr. Andersen rose to make a recommendation that the item be downgraded to an Information status to allow the USN WG time to further develop it. He stated that proposed paragraph S.1.1.1. Recording Elements does not provide enough clarity for a person to interpret it correctly. In his view, those reading the paragraph could only interpret it to mean a ticket printer is required. He noted the taxi companies that are already equipped with printers are primarily located in larger cities and smaller companies, which will also be impacted by the proposed change, haven't been given an opportunity to review and comment on those changes. Mr. Andersen further stated these smaller companies are regulated primarily through local regulations, which have been vetted by those companies.

Mr. Sikula requested an interpretation of the paragraph, asking "If the proposal is adopted, will all taxis be required to have a printer?"

Mr. Ryan Wanttaja (New York City Taxi and Limousine Commission), a member of the USN WG, in response to Mr. Sikula's question, stated the proposed paragraph is a "Specification" requirement, not a "User Requirement." The paragraph is simply saying that taxis must have the capability of providing a receipt.

Ms. Rausen expanded upon Mr. Wanttaja's comment by stating that the interpretation of the proposed changes by the USN WG is that a taximeter must be capable of accepting a printer *and* that a taximeter provides a receipt, if a jurisdiction requires it. Mr. Barton voiced agreement with the interpretation provided.

A Vote on the item was then taken and the item adopted.

#### **Regional Association Meetings:**

**CWMA 2014 Interim Meeting:** The CWMA S&T Committee received comments supporting further development of this item. It was noted that this item has been under development for two years by the NIST USN WG on Taximeters. Multiple jurisdiction voiced support for this item. The CWMA thinks this is sufficiently developed and forwarded the item to the NCWM, recommending it as a Voting item. No comments were received on this item during the 2015 CWMA Annual Meeting Open Hearings. The CWMA recommended this item move forward as a Voting item.

**WWMA 2014 Annual Meeting:** During Open Hearings, a member of the USN WG on Taximeters reported this item has been in development for three years and is ready to be moved forward for Vote. Further, he stressed it is imperative that these changes be adopted to ensure the weights and measures community stay current with today's environment. No opposition to this item was presented. The WWMA recognizes the amount of work that has been done on this item and forwarded it to the NCWM, recommending that it be a Voting item. Further, the WWMA recommends that 2014 WWMA S&T Committee Items 354-1, 354-2, 354-3, 354-4, and 354-5 be combined into one proposal.

**SWMA 2014 Annual Meeting:** The SWMA did not hear any comments in opposition to this item. The SWMA recommended that Items 354-1 through 354-5 be combined into one Agenda item since they are all related to taximeters. Comments were heard for all five of these agenda items at the same time. The SWMA forwarded this item to the NCWM, recommending it as a Voting item.

**NEWMA 2014 Interim Meeting:** NEWMA received comment from a member of the USN WG on Taximeters that the language has been cleaned up in the Taximeters Code as new technology and point-of-sale systems are becoming more prevalent in all the states. There was no opposition to this item, and it was recommended that it move forward for a Vote. It was suggested that related Items 354-1, 354-2, 354-3, 354-4, and 354-5 be combined into a single item. NEWMA forwarded the item to NCWM recommending it as a Voting item.

**NEWMA 2015 Annual Meeting:** The NEWMA S&T Committee agreed to group together Taximeter Items 354-1 through 354-5 since it considered all of these items related. Comments were received in support of the 354 group of items by members of the USN WG on Taximeters. With respect to Item 354-1, Mr. Ross Anderson expressed concern regarding the need to include a printed receipt as part of the NIST Handbook 44 code. With respect to Item 354-2, Mr. Andersen commented that he does not believe flat fares would advance the indicating element. In response to Mr. Andersen's comments associated with Item 354-1, a member of the USN WG on Taximeters stated that printed receipts are absolutely needed and should be made available to customers. NEWMA agreed to recommend Taximeter Agenda Items 354-1 through 354-5 move forward for Vote.

Following completion of the voting session at the 2015 NEWMA Annual Meeting, the NEWMA S&T Committee was approached by Mr. Mike Sikula, who raised two concerns regarding the proposals to amend the Taximeters Code as follows.

1. With respect to Agenda Item 354-1, the concern noted was it is not clear whether or not the proposed paragraph would allow printed receipts to be mailed to customers rather than require they be provided to them at time of transaction. An additional related concern was that proposed paragraph S.1.1.1. should be a “User Requirement” instead of a “Specifications” requirement because the intent of the paragraph is that customers be provided a receipt at time of transaction. After questioning a member of the USNWG on Taximeters regarding the differences in a taximeter and taximeter system, the NIST Technical Advisor noted that he did not believe mailing a printed receipt to the customer would satisfy what is required by proposed paragraph S.1.1.1. The Committee agreed that proposed paragraph S.1.1.1. should appear as a “Specifications” requirement in NIST Handbook 44 because it addresses the design of equipment (i.e., the proposed paragraph would require a taximeter or taximeter system to provide transaction information on a receipt). The Committee noted, if the intent of the USNWG is to require a receipt be provided to customers, it should consider proposing a new “User Requirement” to address this concern.
2. With regard to Agenda Item 354-2, the concern noted was that proposed subparagraph S.1.2.(d) is in conflict with the title of paragraph S.1.2. Advancement of Indicating Elements in that flat rate transactions are not based on any advancement of the indicating elements. It was also noted the current Taximeters Code Paragraph S.2. requires fares to be based on distance traveled, time elapsed, or a combination of both.

The NEWMA S&T Committee suggested to Mr. Sikula that he participate in an upcoming tele-conference with the USNWG (scheduled to take place shortly after the NEWMA Annual Meeting) to make known his concerns in order that the USNWG could address them. NEWMA’s S&T Committee indicated it believed there was still sufficient time for the USNWG to propose changes to the items prior to being presented for Vote at the upcoming NCWM Annual Meeting.

Additional letters, presentations, and data may have been part of the Committee’s consideration. To review the supporting documentation, please refer to the *Report of the 99<sup>th</sup> National Conference on Weights and Measures* (SP1193, 2014).

### **354-2 I S.1.2. Advancement of Indicating Elements.**

**Source:**

NIST USNWG on Taximeters (2015)

**Purpose:**

Allow for the advancement of fare indication by the input of a flat rate where the local authority permits the use of flat rates and provide clarification that charges displayed on the taximeter other than fare may occur by a manual input or by an automatic means.

**Item Under Consideration:**

Amend NIST Handbook 44, 5.54. Taximeter Code as follows:

**S.1.2. Advancement of Indicating Elements.** – Except when a taximeter is being cleared, the **fare charges displayed on the** primary indicating and recording elements shall **advance** ~~be susceptible of advancement~~ only by:

- (a) the movement of the vehicle;
- (b) by the time mechanism;
- (c) **the movement of the vehicle and by the time mechanism but shall not occur by both of these means operating simultaneously (see also S.4. Interference).; or**

**(d) the entry of a monetary amount associated with a flat rate or negotiated rate where permitted.**

**Advancement of the indications for charges, other than fare may occur through manual or automatic means.**

(Amended 1988, **and 20XX**)

**Background/Discussion:**

The USNWG on Taximeters has determined that in some jurisdictions alternative types of fare charges such as flat rate-based fares are permitted by local authorities. These flat rate charges are not dependent on the calculation of distance and/or time via a taximeter but are based instead on established fixed amounts charged for trips between common origins and destinations (e.g., airports, hotels, and business districts). The intent of this proposed amendment is to allow for the advancement of fare indication by the input of a flat rate where the local authority permits the use of flat rates. Where the use of flat rates (and negotiated flat rates) is permitted, a display of the flat rate on the taximeter provides the passenger with verification of the charge applied to the service.

In addition, while this type of rate is not based on calculations by the taximeter, in some cases, taxi companies will track transactions and revenue by way of the data processed through the taximeter. These companies will, therefore, want all transactions to be processed through the taximeter as a means to account for all activities of the taxi.

The existing requirement in paragraph S.1.2. only allows the primary indications of a taximeter to be advanced through the motion of the vehicle or by the time mechanism and does not allow for the fare indication to be advanced by the input of a flat rate amount. This proposed amendment clarifies that the requirement only specifies the means of advancement for the indication of *fare* charges and *not* extras charges or other displayed indications. Because other types of charges that will be displayed on the taximeter (i.e., extras and additional charges) can be either entered manually into the taximeter or may be automatically entered, the proposed amendment also provides clarification that charges displayed on the taximeter other than fare may occur by a manual input or by an automatic means.

The reformatting of the existing paragraph through the use of bullets (a-d) is believed to improve the structure and the clarity of the requirement.

**2015 NCWM Interim Meeting:**

During the 2015 NCWM Interim Meeting, the Committee agreed to group together all of the “354” Taximeter Items (i.e., Agenda Items 354-1 through 354-6, inclusive) since it considered these items related and announced that comments on all six items would be taken together during the Open Hearings. See Agenda Item 354-1 for a summary of comments received during the Open Hearings relating to these items.

With respect to this particular Item 354-2, the Committee agreed to replace the language in the original proposal (shown in the box below), with that recommended by the SWMA, shown in “Item Under Consideration,” and recommend the item for Vote at the July NCWM Annual Meeting.

**Original Proposal:**

**S.1.2. Advancement of Indicating Elements.** – Except when a taximeter is being cleared, the **fare charges displayed on the** primary indicating and recording elements shall be susceptible of advancement only by:

- (a) the movement of the vehicle;
- (b) by the time mechanism;
- (c) **a combination of both a) and b\*); or**
- (d) **the entry of a monetary amount associated with a flat rate or negotiated rate where permitted.**

**Advancement of the indications for charges, other than fare may occur through manual or automatic means.**

**\*The advancement of fare may occur by either the movement of the vehicle or by the time mechanism but shall not occur by both of these means operating simultaneously (see also S.4. Interference).**

(Amended 1988, **and 20XX**)

#### **2015 NCWM Annual Meeting:**

NCWM 2015 Annual Meeting: The Committee agreed to group together Agenda Items 354-1 through 354-5 and 360-3 and take comments simultaneously on these six items. See Agenda Item 354-1 for the summary of comments provided on these items.

Although grouped by the Committee with the other “taximeter” items, the Committee agreed during its work session to make this item a stand-alone Voting item due to comments heard during the Open Hearings recommending this item be downgraded to Informational.

During the voting session, when asked if there were any comments on Agenda Item 354-2, Ms. Kristin Macey (California) rose to request that the Committee downgrade this item to Informational. She noted that members of the USNWG are the experts, and they had recommended this action to allow time for the group to continue working on the proposal.

Mr. Ross Andersen (New York, retired) also recommended the item be downgraded to Informational. He stated that a flat fare is not associated with the advancement of the indicating elements and, therefore, should not be a part of paragraph S.1.2. Advancement of Indicating Elements.

Mr. Mike Sikula (New York) noted that a “flat rate” does not meet the definition of “fare” in Appendix D of NIST Handbook 44 in that the word “fare,” according to the definition, is calculated through the operation of the distance and/or time mechanism of a taximeter. A flat rate is not calculated by distance or time.

The Committee took a short recess to consider the comments heard during the Voting session. In consideration of those comments, the Committee agreed to downgrade this item to Informational.

#### **Regional Association Meetings:**

CWMA 2014 Interim Meeting: The CWMA S&T Committee received comments supporting further development of this item. It was noted that this item has been under development for two years by the NIST USNWG on Taximeters. Multiple jurisdictions voiced support for this item. The CWMA thinks this is sufficiently developed and forwarded the item to the NCWM, recommending it as a Voting item. No comments were received on this item during the 2015 CWMA Annual Meeting Open Hearings. The CWMA recommended this item move forward as a Voting item.

WWMA 2014 Annual Meeting: At the Open Hearings, a member of the USNWG on Taximeters reported that this proposal has been in development for three years and is ready to be a Voting item. Further, he stressed that it is imperative that these changes be adopted to ensure the weights and measures community stay current with today’s environment. No opposition to this item was presented. The WWMA recognizes the amount of work that has been done on this item and forwarded it to the NCWM, recommending that it be a Voting item. Further, the WWMA recommends that 2014 WWMA S&T Committee Items 354-1, 354-2, 354-3, 354-4, and 354-5 be combined into one proposal.

SWMA 2014 Annual Meeting: The SWMA did not hear any comments in opposition to this item and made recommendations based on confusion during review of the item. The Committee recommended that Items 354-1 through 354-5 be combined into one Agenda item, since they are all related to taximeters. Comments were heard for all five of these agenda items at the same time. The SWMA forwarded this item to the NCWM, recommending it as a Voting item as amended below:

**S.1.2. Advancement of Indicating Elements.** – Except when a taximeter is being cleared, the **fare charges displayed on the** primary indicating and recording elements shall ~~advance~~ ~~be susceptible of advancement~~ only by:

- (a) the movement of the vehicle;
- (b) by the time mechanism;
- (c) **the movement of the vehicle and by the time mechanism but shall not occur by both of these means operating simultaneously (see also S.4. Interference).; or**
- (d) **the entry of a monetary amount associated with a flat rate or negotiated rate where permitted.**

**Advancement of the indications for charges, other than fare may occur through manual or automatic means.**

(Amended 1988, **and 20XX**)

NEWMA 2014 Interim Meeting: NEWMA received comment from a member of the USNWG on Taximeters that the language has been cleaned up in the NIST Handbook 44 Taximeters Code as new technology and point-of-sale systems are becoming more prevalent in all the states. It was suggested that related Items 354-1, 354-2, 354-3, 354-4, and 354-5 be combined into a single item. Since there was no opposition to this item, NEWMA agreed to forward the item to the NCWM, recommending it as a Voting item.

NEWMA 2015 Annual Meeting: The NEWMA S&T Committee agreed to group together Agenda Items 354-1 through 354-5 and take comments simultaneously on all these items since it considered them related. Refer to Agenda Item 354-1 to view the comments received by the Committee on this group of agenda items. NEWMA agreed to recommend Taximeter Agenda Items 354-1 through 354-5 move forward for vote.

Additional letters, presentations, and data may have been part of the Committee's consideration. To review the supporting documentation, please refer to the *Report of the 99<sup>th</sup> National Conference on Weights and Measures* (SP1193, 2014).

### **354-3 VC S.1.3.3. Passenger Indications.**

(This item was Adopted.)

**Source:**

NIST USNWG on Taximeters (2015)

**Purpose:**

Require that when a supplementary customer display is present in a taxi: (1) the accruing total charge shall be evident to the passenger; and (2) an itemized listing of the details for charges incurred is made available to the customer.

**Item Under Consideration:**

Amend NIST Handbook 44, 5.54. Taximeters Code as follows:

**S.1.3.3. Passenger's Indications. – A supplementary indicating element installed in a taxi to provide information regarding the taxi service to the passenger, shall clearly display the current total of all charges incurred for the transaction. The accruing total of all charges must remain clearly visible on the passenger's display (unless disabled by the passenger) at all times during the transaction.**

**S.1.3.3.1. Additional Information – Additional information shall be displayed or made available through a passenger's indicating element (as described in S.1.3.3. Passenger's Indications) and shall be current and reflect any charges that have accrued. This additional information shall include:**

- (a) an itemized account of all charges incurred including fare, extras, and other additional charges; and**

**(b) the rate(s) in use at which any fare is calculated.**

**Any additional information made available must not obscure the accruing total of charges for the taxi service. This additional information may be made accessible through clearly identified operational controls (e.g., key pad, button, menu, touch-screen).**

**S.1.3.3.2. Fare and Extras Charges – The indication of fare and extras charges on a passenger’s indicating element shall agree with similar indications displayed on all other indicating elements in the system.**

**[Nonretroactive as of January 1, 2016]**

**(Added 2015)**

**Background/Discussion:**

The USNWX on Taximeters recognizes supplementary indicating elements that are installed in the passenger’s area in a taximeter are becoming more prevalent. At this time, there are no specific requirements that to address this type of device (sometimes referred to as passenger information monitors or PIMs) although they are being installed in taximeter systems in increasing numbers. Because these devices are commonly used to provide the passenger with details and information pertaining to the taxi service, the USNWX agreed that there must be appropriate requirements in NIST Handbook 44 that address the manner in which this information is presented.

The addition of the proposed new requirements S.1.3.3., S.1.3.3.1., and S.1.3.3.2. in the Taximeters Code provides specification requirements for this type of indicating element. These new paragraphs provide manufacturers with design criteria for new devices and provide regulatory authorities with requirements to ensure that the passenger is supplied with sufficient information necessary to verify the cost of the transportation service provided.

The USNWX considered the most important single data item for the passenger to be the accruing total of all charges during the trip. In this proposal, this information is required to be clearly visible on the passenger’s display at all times during the trip. Itemized details of individual charges and other information of importance must be made available to the passenger via these passenger’s indicating elements. In consideration of the limited size of the typical display area on this type of device, information other than the accruing total of charges need not be displayed constantly but must be available to the customer by clearly marked means through the operational controls on the device.

Because the primary indicating element in a system (the taximeter) will display the fare and extras indications, any supplemental device, which also displays these indications, must be in agreement with the taximeter. To address this, the proposed new S.1.3.3.2. would require that the display of fare and extras charges is in agreement with those same indications as displayed on other indicating elements in the system.

**2015 NCWM Interim Meeting:**

NCWM 2015 Interim Meeting: The Committee agreed to group together all of the “354” Taximeter Items (i.e., Agenda Items 354-1 through 354-6, inclusive) since it considered these items related and announced that comments on all six items would be taken together during the Open Hearings. See Agenda Item 354-1 for a summary of comments received during the Open Hearings relating to these items.

With respect to this particular item (354-3), the Committee agreed to assign an effective, nonretroactive enforcement date of January 1, 2016, to proposed new paragraph S.1.3.3. Passenger’s Indications and to recommend the item for Vote at the July NCWM Annual Meeting.

**2015 NCWM Annual Meeting:**

NCWM 2015 Annual Meeting: The Committee agreed to group together Agenda Items 354-1 through 354-5 and 360-3 and take comments simultaneously on these six items. See Agenda Item 354-1 for the summary of comments provided on these items.

**Regional Association Meetings:**

CWMA 2014 Interim Meeting: During the meeting the CWMA S&T Committee received comments supporting further development of this item. It was noted that this item has been under development for two years by the NIST USNWX on Taximeters. Multiple jurisdictions voiced support for this item. The CWMA thinks this is sufficiently developed and forwarded the item to the NCWM, recommending it as a Voting item. No comments were received on



this item during the 2015 CWMA Annual Meeting Open Hearings. The CWMA recommended this item move forward as a Voting item.

WWMA 2014 Annual Meeting: During Open Hearings, a member of the USNWG on Taximeters reported that this proposal has been in development for three years and is ready to be a Voting item. Further, he stressed that it is imperative that these changes be adopted to ensure the weights and measures community stay current with today's environment. No opposition to this item was presented. The WWMA recognizes the amount of work that has been done on this item and forwarded it to NCWM, recommending that it be a Voting item. Further, the WWMA recommended that 2014 WWMA S&T Committee Items 354-1, 354-2, 354-3, 354-4, and 354-5 be combined into one proposal.

SWMA 2014 Annual Meeting: The SWMA did not hear any comments in opposition to this item. The SWMA recommended that Items 354-1 through 354-5 be combined into one agenda item since they are all related to taximeters. Comments were heard for all five of these agenda items at the same time. The SWMA forwarded this item to the NCWM and recommended it as a Voting item.

NEWMA 2014 Interim Meeting: NEWMA received comment from a member of the USNWG on Taximeters that the language has been cleaned up in the NIST Handbook 44 Taximeters Code as new technology and point-of-sale systems are becoming more prevalent in all the states. It was suggested that related Items 354-1, 354-2, 354-3, 354-4, and 354-5 be combined into a single item. Since there was no opposition to this item, NEWMA agreed to forward the item to the NCWM, recommending it as a Voting item.

NEWMA 2015 Annual Meeting: The NEWMA S&T Committee agreed to group together Agenda Items 354-1 through 354-5 and take comments simultaneously on all of these items since it considered them related. Refer to Agenda Item 354-1 to view the comments received by the Committee on this group of agenda items. NEWMA agreed to recommend Taximeter Agenda Items 354-1 through 354-5 move forward for Vote.

Additional letters, presentations, and data may have been part of the Committee's consideration. To review the supporting documentation, please refer to the *Report of the 99<sup>th</sup> National Conference on Weights and Measures* (SP1193, 2014).

### **354-4 VC S.1.8. Protection of Indications.**

(This item was Adopted.)

**Source:**

NIST USNWG on Taximeters (2015)

**Purpose:**

Update specifications to reflect present day technology.

**Item Under Consideration:**

Amend NIST Handbook 44, 5.54. Taximeters Code as follows:

**S.1.8. Protection of Indications.** – All indications of fare and extras shall be ~~displayed through and entirely protected by glass or other suitable transparent material securely attached to the housing of the taximeter~~ protected from unauthorized alteration or manipulation.

**(Amended 2015)**

**Background/Discussion:**

This requirement was drafted when taximeters consisted of mechanical-type meters whose displays were much more susceptible to manipulation and today are rarely (if ever) found to be still in service. The proposed amendment to Paragraph S.1.8. serves to update this requirement with respect to current technology. Paragraph S.1.8. requires that taximeter indications should be protected from manipulation (accomplished relatively easily on mechanical-type

indications) through physical means. Electronic/digital type indications are less subject to physical manipulation although; those indications could potentially be manipulated through electronic means.

**2015 NCWM Interim Meeting:**

NCWM 2015 Interim Meeting: During the meeting, the Committee agreed to group together all of the “354” Taximeter items (i.e., Agenda Items 354-1 through 354-6, inclusive) since it considered these items related and announced that comments on all six items would be taken together during the Open Hearings. See Agenda Item 354-1 for a summary of comments received during the Open Hearings relating to these items.

With respect to this particular Item (354-4), the Committee agreed to recommend the item for Vote at the July NCWM Annual Meeting.

**2015 NCWM Annual Meeting:**

NCWM 2015 Annual Meeting: The Committee agreed to group together Agenda Items 354-1 through 354-5 and 360-3 and take comments simultaneously on these six items. See Agenda Item 354-1 for the summary of comments provided on these items.

**Regional Association Meetings:**

CWMA 2014 Interim Meeting: The CWMA’s S&T Committee received comments supporting further development of this item. It was noted that this item has been under development for two years by the NIST USNWG on Taximeters. Multiple jurisdiction voiced support for the item. CWMA thinks this is sufficiently developed and forwarded the item to NCWM, recommending it as a Voting item. No comments were received on this item during the 2015 CWMA Annual Meeting Open Hearings. The CWMA recommended this item move forward as a Voting item.

WWMA 2014 Annual Meeting: During the Open Hearings, a member of the USNWG on Taximeters reported that this proposal has been in development for three years and is ready to be a Voting item. Further, he stressed that it is imperative these changes be adopted to ensure the weights and measures community stay current with today’s environment. No opposition to this item was presented. The WWMA recognizes the amount of work that has been done on this item and forwarded it to NCWM, recommending that it be a Voting item. Further, the WWMA recommends that 2014 WWMA S&T Committee Items 354-1, 354-2, 354-3, 354-4, and 354-5 be combined into one proposal.

SWMA 2014 Annual Meeting: The SWMA did not hear any comments in opposition to this item. SWMA recommended that Items 354-1 through 354-5 be combined into one Agenda item since they are all related to taximeters. Comments were heard for all five of these agenda items at the same time. SWMA forwarded this item to NCWM and recommended it as a Voting item.

NEWMA 2014 Interim Meeting: NEWMA received comment from a member of the USNWG on Taximeters that the language has been cleaned up in the Taximeter Code as new technology and point-of-sale systems are becoming more prevalent in all the states. As there was no opposition to this item, it was recommended that the item move forward to a Vote. It was suggested that related Items 354-1, 354-2, 354-3, 354-4, and 354-5 be combined into a single item. NEWMA forwarded the item to NCWM recommending it as a Voting item.

NEWMA 2015 Annual Meeting: The NEWMA S&T Committee agreed to group together agenda Items 354-1 through 354-5 and take comments simultaneously on all of these items since it considered them related. Refer to Agenda Item 354-1 to view the comments received by the Committee on this group of agenda items. NEWMA agreed to recommend Taximeter Agenda Items 354-1 through 354-5 move forward for Vote.

Additional letters, presentations, and data may have been part of the Committee’s consideration. To review the supporting documentation, please refer to the *Report of the 99<sup>th</sup> National Conference on Weights and Measures* (SP1193, 2014).

**354-5 VC S.1.9. Recorded Representation.**

(This item was Adopted.)

**Source:**

NIST USNWG on Taximeters (2015)

**Purpose:**

Ensure that taximeter systems can generate receipts with the clear detail of the various charges.

**Item Under Consideration:**

Amend NIST Handbook 44, 5.54. Taximeter Code as follows:

***S.1.9. Recorded Representation.*** – *A printed receipt issued from a taximeter, whether through an integral or separate recording element, shall include as a minimum, the following information when processed through the taximeter system:*

- (a) *date;*
- (b) *unique vehicle identification number, such as the medallion number, taxi number, vehicle identification number (VIN), ~~or~~ permit number, or other identifying information as specified by the statutory authority;\**
- (c) *start and end time of trip;\**
- (d) *distance traveled, maximum increment of 0.1 kilometer (0.1 mile);\**
- (e) *fare in \$;*
- (f) *~~for multi-rate taximeters,~~ each rate at which fare was computed and the associated fare at that rate;\**
- (g) *additional charges in \$, where permitted, such as extras, any surcharges, ~~telephone use telecommunications charges, tip~~ and taxes shall be identified and itemized; ~~\*and~~*
- (h) *total fare charge for service in \$ (~~total charge inclusive of fare, extras, and all additional charges~~);<sup>i</sup>\**
- (i) *trip number, if available;\*\* and*
- (j) *telephone number (or other contact information) for customer assistance.\*\**

***Note: When processed through the taximeter or taximeter system, any adjustments (in \$) to the total charge for service including discounts, credits, and tips shall also be included on the receipt\*\****

*[Nonretroactive as of January 1, 1989] \*[Nonretroactive as of January 1, 2000] **\*\*[Nonretroactive as of January 1, 2016]***

(Added 1988) (Amended 1999 **and 2015**)

**Background/Discussion:**

Upon reviewing the existing requirement, S.1.9. Recorded Representation, the USNWG on Taximeters agreed that additional information provided on a receipt issued by a taximeter or taximeter system would be a benefit by providing more detail for the passenger to interpret charges for that type of service or to provide assistance to the passenger in the case of any disputed charges involved in a transaction.

The WG also recognized that there may be some details involved in a transaction that may not be processed through the taximeter or taximeter system. An example of this could be when the charge for taxi service is paid by credit card and the passenger elects to give the driver a cash tip afterwards. Another example could be when a credit or discount is accepted but the taximeter is not capable of processing the adjustment to the total charge. To account for this type of alteration of charges, the proposed amendment specifies that information required to be included on the receipt must be information that is capable of being processed through the taximeter or taximeter system.

Other proposed changes include the allowance for the statutory authority to specify other information needed to positively identify a particular vehicle, the deletion of extraneous language (e.g., for multi-rate taximeters), and the replacement of obsolete language with more relevant terms (i.e., telecommunications charges). Also added to the list of required information was contact information for the passenger to seek customer assistance.

### **2015 NCWM Interim Meeting**

NCWM 2015 Interim Meeting: The Committee agreed to group together all of the “354” Taximeter Items (i.e., Agenda Items 354-1 through 354-6, inclusive) since it considered these items related and announced that comments on all six items would be taken together during the Open Hearings. See Agenda Item 354-1 for a summary of comments received during the Open Hearings relating to these items.

With respect to this particular item (354-5), the Committee agreed to assign an effective, nonretroactive enforcement date of January 1, 2016, to those portions of the paragraph identified using two asterisks (\*\*) and recommend the item as shown in “Item Under Consideration” for Vote at the July NCWM Annual Meeting.

### **2015 NCWM Annual Meeting**

NCWM 2015 Annual Meeting: The Committee agreed to group together Agenda Items 354-1 through 354-5 and 360-3 and take comments simultaneously on these six items. See Agenda Item 354-1 for the summary of comments provided on these items.

### **Regional Association Meetings:**

CWMA 2014 Interim Meeting: The CWMA S&T Committee received comments supporting further development of this item. It 2014 was noted this item has been under development for two years by the NIST USNWG on Taximeters. Multiple jurisdictions voiced support for this item. The CWMA thinks this is sufficiently developed and forwarded the item to the NCWM, recommending it as a Voting item. No comments were received on this item during the 2015 CWMA Annual Meeting Open Hearings. The CWMA recommended this item move forward as a Voting item.

WWMA 2014 Annual Meeting: During the Open Hearings, a member of the USNWG on Taximeters reported that this proposal has been in development for three years and is ready to be a Voting item. Further, he stressed that it is imperative that these changes be adopted to ensure the W&M community stay current with today’s environment. No opposition to this item was presented. The WWMA recognizes the amount of work that has been done on this item and forwarded it to NCWM, recommending that it be a Voting item. Further, the WWMA recommends that 2014 WWMA S&T Committee Items 354-1, 354-2, 354-3, 354-4, and 354-5 be combined into one proposal.

SWMA 2014 Annual Meeting: The SWMA did not hear any comments in opposition to this item. The SWMA recommended that Items 354-1 through 354-5 be combined into one agenda item since they are all related to taximeters. Comments were heard for all five of these agenda items at the same time. The SWMA forwarded this item to the NCWM and recommended it as a Voting item.

NEWMA received comment from a member of the USNWG on Taximeters that the language has been cleaned up in the NIST Handbook 44 Taximeters Code as new technology and point-of-sale systems are becoming more prevalent in all the states. It was suggested that related Items 354-1, 354-2, 354-3, 354-4, and 354-5 be combined into a single item. Since there was no opposition to this item, NEWMA agreed to forward the item to the NCWM, recommending it as a Voting item.

NEWMA 2015 Annual Meeting: The NEWMA S&T Committee agreed to group together Agenda Items 354-1 through 354-5 and take comments simultaneously on all of these items since it considered them related. Refer to

Agenda Item 354-1 to view the comments received by the Committee on this group of Agenda items. NEWMA agreed to recommend Taximeter Agenda Items 354-1 through 354-5 move forward for Vote.

Additional letters, presentations, and data may have been part of the Committee's consideration. To review the supporting documentation, please refer to the *Report of the 99<sup>th</sup> National Conference on Weights and Measures* (SP1193, 2014).

### **354-6 D USNWG on Taximeters – Taximeter Code Revisions and Global Positioning System-Based Systems for Time and Distance Measurement**

*Note: This item was originally titled “Item 360-5, S.5. Provision for Security Seals” in the Committee’s 2013 Interim Agenda. At the 2013 NCWM Interim Meeting, the Committee combined that item with “Item 354-1 Global Positioning Systems for Taximeters” and “Item 360-6 Global Positioning Systems for Taximeters” to create this new, consolidated item to address the development of recommendations on multiple topics related to taximeters and GPS-based time and distance measuring systems.*

**Source:**

NIST USNWG on Taximeters

**Purpose:**

Develop recommendations for modifying the existing 5.54. Taximeters Code to reflect current technology (including requirements for sealing, display requirements, and other features) and to examine GPS-based time and distance measuring systems to determine how to best address these measuring systems in NIST Handbook 44 to ensure accuracy and transparency for passengers and businesses.

**Item Under Consideration:**

This item is under development. Comments and inquiries may be directed to Mr. John Barton (NIST, OWM) at (301) 975-4002 or [john.barton@nist.gov](mailto:john.barton@nist.gov).

The USNWG is considering proposals to modify the sealing requirements in the Taximeters Code to reflect more advanced sealing methods (see 2012 NCWM Final S&T Report); to amend the Taximeters Code to specifically recognize GPS-based time and distance measuring systems; and to amend other sections of the Taximeters Code to reflect current technology and business practices while ensuring accuracy and transparency for customers and a level playing field for transportation service companies.

**Background/Discussion:**

The Committee has received multiple proposals over the past several years related to updating the current NIST Handbook 44, Taximeters Code to reflect current technology as well as a request to establish criteria for GPS-based time and distance measuring systems. In April 2012, NIST OWM established a USNWG to work on these issues. The USNWG has met multiple times since it was established. For details of those meetings as well as the current proposals being developed by the USNWG, please contact Mr. Barton as noted in the “Item Under Consideration” above.

Additional background information and updates on the progress associated with this item can be found in the Committee’s 2014 and earlier final reports.

**2015 NCWM Interim Meeting:**

NCWM 2015 Interim Meeting: The Committee agreed to group together all of the “354” Taximeter Items (i.e., Agenda Items 354-1 through 354-6, inclusive) since it considered these items related and announced that comments on all six items would be taken together during the Open Hearings. See Agenda Item 354-1 for a summary of comments received during the Open Hearings relating to these items.

With respect to this particular item (354-6) the Committee agreed to assign it a Developing status based on the update provided by the NIST Technical Advisor to the USNWG on Taximeters indicating the item is still being developed.

**2015 NCWM Annual Meeting:**

NCWM 2015 Annual Meeting: During the Open Hearings, the Committee heard comments from several officials voicing concern about the limited amount of progress being made by the WG to develop requirements to address GPS-based time and distance measuring systems and the need for those requirements. Mr. Jimmy Cassidy (City of Cambridge, Massachusetts), a member of the USNWG on Taximeters, reported that this item needed to be revived and that the USNWG needed fresh ideas on how best to proceed.

Mr. John Barton (OWM), NIST Technical Advisor to the USNWG reported that there is a large amount of proprietary information involved in the development of this type of system that the manufacturers of these systems are not willing to share. This is a major challenge for the USNWG to overcome in order to move forward in this effort.

Ms. Kristin Macey (California) suggested developing proposed requirements that are performance based. She assured those concerned that testing can be accomplished and indicated that California is currently type evaluating a GPS-based device. She suggested possibly downloading the taxi service provider's application onto an iPhone or iPad and verifying the accuracy of the system over a track as is currently done when testing a conventional taximeter in accordance with NIST Handbook 44 test procedures.

Mr. Ross Andersen (New York, retired) commented that current taximeter tests may not be appropriate in that it specifies the track should be straight. He noted that GPS based systems are more sensitive side-to-side than to changes in elevation. He also questioned the factors being used by the service providers to determine a customer's rate and suggested more work is needed in this area. A final suggestion was that the USNWG concentrate efforts on developing methods of testing system performance.

The Committee agreed to maintain the Developing status of this item and looks forward to future refinements by the submitter.

**Regional Associations Meetings:**

CWMA 2014 Interim Meeting: The CWMA did not receive comments on this item at its Interim Meeting or the 2015 Annual Meeting and agreed at both meetings to recommend that the item be forwarded to NCWM as a Developing item.

WWMA 2014 Annual Meeting: During the WWMA Open Hearings, a NIST representative stated that NIST is currently in the process of contracting a chair for the Sub-committee. The WWMA recommends that this item remain as a Developing item to allow more work to be completed in this area.

SWMA 2014 Annual Meeting: The SWMA expressed support for the work of the USNWG on Taximeters and agreed to recommend this item move forward as a Developing item.

NEWMA 2014 Interim Meeting: NEWMA received comments from members of the USNWG that an updated proposal was near completion. NEWMA recommended that this item remain a Developing item. At the 2015 NEWMA Annual Meeting, NEWMA noted that no comments were received and agreed to recommend the item be forwarded to NCWM as a Developing item.

Additional letters, presentations, and data may have been part of the Committee's consideration. To review the supporting documentation, please refer to the *Report of the 99<sup>th</sup> National Conference on Weights and Measures* (SP1193, 2014).

## 358 MULTIPLE DIMENSION MEASURING DEVICES

### 358-1 W Measurement of Bulk Material in Open-Top Truck and Trailer Units

(This item was Withdrawn.)

**Source:**

LoadScan U.S. (2014)

**Purpose:**

Develop a standardized testing protocol for a non-contact volumetric measurement instrument designed to measure loads of bulk loose solids in open-top truck and trailer units.

**Item Under Consideration:**

Develop new language for type classification, accuracy classification, and test methodology for load volume scanning devices.

**Background/Discussion:**

Laser technology allows for accurate volume measurement of bulk materials loaded on open-top truck and trailer bodies. Standard industry practice is to count loader buckets or convert from weight, both highly variable and inaccurate ways of measuring cubic volume.

Contacts: Mr. Peter Russell, LoadScan U.S., Tel: (603) 831-6014 or e-mail: [peter.russell@loadscan.us](mailto:peter.russell@loadscan.us); and Mr. Adrian Ruthe, Loadscan Ltd., Tel: +64 7-847-5777 or e-mail: [adrian@loadscan.com](mailto:adrian@loadscan.com).

NCWM 2014 Interim Meeting: Mr. Peter Russell (LoadScan, Ltd.) and Mr. Adrian Ruthe (LoadScan, Ltd.) provided a joint presentation regarding the operation of a device that uses a scanner to measure the volume of product loaded into open-top truck and trailer units. Mr. Russell and Mr. Ruthe indicated that they were not familiar with the procedures of how to go about adding new requirements into NIST Handbook 44; nor did they know where in NIST Handbook 44 requirements intended to apply to their equipment would best fit. They asked the Committee for guidance on how best to proceed concerning these issues.

The Committee acknowledged that there is not yet a specific proposal to consider and that additional information and input is needed for the development of this item. The Committee agreed to designate this item as a Developing item on its agenda to allow time for the issue to be further developed by the submitter. The Committee noted that a specific proposal outlining recommended changes to NIST Handbook 44 is needed in order for the item to advance through the process.

While the Committee is not certain if the MDMD Code is the most appropriate code for addressing these devices, the Committee suggested that the MDMD WG might be willing to consider this issue and provide input on further development of draft NIST Handbook 44 language. Alternatively, or in addition, the submitter may wish to contact the NTEP Weighing Sector to determine if the Sector or its members might be able to provide additional assistance.

The Committee received a document from the submitter (titled "Load Volume Scanner, Proposals for Integration into NIST Handbook 44") that provided additional information and supporting arguments for addressing this issue, along with some recommended changes to NIST Handbook 44. The Committee included these documents as Appendices F and G in its 2014 Final Report (NIST SP 1193, "Report of the 99<sup>th</sup> National Conference on Weights and Measures").

NCWM 2014 Annual Meeting: The NIST Technical Advisor reported he had contacted LoadScan, Ltd. and was provided the following update:

LoadScan, Ltd. in New Zealand is aware that the NCWM Annual Meeting is coming up. Unfortunately, the reality is we have not had the resources to be able to pursue our case this year and will not be making any submissions at the moment. We plan to engage the services of local experts within the USA to pursue this

matter for us over the next year. We are also completing further background work with Weights & Measures authorities in New Zealand and Australia which we hope will support our drive for approval in the U.S.A. At this stage we request only to retain our ‘Developing item’ status.

### **2015 NCWM Interim Meeting:**

NCWM 2015 Interim Meeting: No one was present to provide an update on the development of this item. NIST, OWM reported that the submitter of the item had not been in contact with NIST, OWM for more than a year; nor had any Committee members been contacted. In summarizing NIST, OWM’s analysis of the item, Ms. Tina Butcher (NIST, OWM) reported that NIST, OWM believes the “LoadScan” equipment measures volume, which is different from a multiple dimensioning measuring device, which measures dimensions to calculate volume. Mr. Darrell Flocken (NTEP) reported that the MDMD WG, in considering this item during its November 2014 meeting, considered the device a “profiler” (i.e., it provides a volume measurement by profiling the load) and not a “dimensional measuring device.”

There were a couple of comments heard in support of continuing development of the item. There were also comments expressing concern over the potential cost of making the reference standards that would be needed to test the device and the minimum value of its increment.

The Committee agreed to Withdraw the item because it had remained on its agenda for more than a year with no progress being reported on its development by the submitter. In withdrawing the item, members of the Committee agreed that the submitter could always submit a new proposal for future consideration should he decide to do so.

### **Regional Associations Meetings:**

CWMA Interim 2014 Meeting: The CWMA received comments indicating that the submitter will continue developing this item. The CWMA supported the continued Development of this item.

WWMA 2014 Annual Meeting: During the Open Hearings, a regulator expressed concern over the accuracy of these types of devices in certain weather conditions (fog and rain). Based on background information in the agenda, it was noted that the item is still developing. The WWMA recommends that this item remain a Developing item to allow the submitter time to address concerns of the weights and measures community.

SWMA 2014 Annual Meeting: The SWMA agreed to recommend the item move forward as a Developing item and noted it looks forward to further development of the item by the submitter.

NEWMA 2014 Interim Meeting: NEWMA reported that it believes that further development is necessary to specify the logistics of how test standards would be developed for this type of device. NEWMA recommended that the item remain as a Developing item.

Additional letters, presentations, and data may have been part of the Committee’s consideration. To review the supporting documentation, please refer to the *Report of the 99<sup>th</sup> National Conference on Weights and Measures* (SP1193, 2014).

## **360 OTHER ITEMS**

### **360-1 W Appendix D – Definitions: batching system.**

(This item was Withdrawn.)

#### **Source:**

KSI Conveyors Inc. (2015)

#### **Purpose:**

Eliminate some confusion in the marketplace and aid field officials in making appropriate decisions on the classification of devices they encounter.



**Item Under Consideration:**

Amend NIST Handbook 44, Appendix D – Definitions as follows:

**batching system. – One in which raw materials are measured in pre-determined quantities by weight and/or liquid measure. The value of the final product may be determined on the basis of the measurement of some or all of the raw material. The unit of measure for the final product may be different from any of the units of measure for the raw materials.**

**Background/Discussion:**

KSi Conveyors Inc. manufactures and distributes systems for treating agricultural seed in 31 states and 3 provinces. The system weighs hybrid seed, applies treatment chemicals, and delivers a finished product that is normally sold on the basis of seed count. Because the system utilizes hopper scale(s) that typically make multiple drafts of a predetermined quantity one state tried to categorize the systems as an automatic bulk weighing system under NIST Handbook 44, Section 2.22. Automatic Bulk Weighing Systems. It is the submitter’s contention that the system is really a batch weighing system and should fall under NIST Handbook 44, Section 2.20. Scales Code. Even though there are numerous NTEP Certificates of Conformance for systems that perform batch weighing functions (including KSi’s) there is no definition for a “batching system” in NIST Handbook 44.

There are a variety of systems used in commerce that provide a finished product based on the measurement of raw materials. The raw materials may be weighed or measured directly by the system, such as a ready mixed concrete batching system. Others may have some raw material measured by devices separate from the batch weighing system such as the drugs added to feed produced by a livestock feed batching system. The final unit of measure for the finished product may be in different terms than that used to measure the raw materials. Charges may be based on a formula for the final product and not actually on the measurements of each ingredient in the recipe.

As examples, a ready mixed concrete system will weigh the aggregate, sand, and cement. Water added to the mix may be weighed or measured. In some cases, other concrete additives, such as hardeners or drying agents are also added. The various amounts of raw materials needed are determined by a “recipe” or the desired end product. Regardless of how the raw materials are measured, the final sale of concrete is based on a measurement of cubic yards that is transferred from the system into a ready mix truck for delivery. The seed treatment system weighs seed that is fed into a treatment drum where treatment chemicals are applied based on the recipe for the desired end product. The treated seed is then transferred into a conveyance means (truck, wagon, or seed box) for delivery to the farmer. The final transaction is based on the number of seeds delivered.

There are numerous NTEP Certificates of Conformance, including those held by KSi for systems that operate as batch weighing systems. Some examples were provided to the Committee for reference.

Adding a definition for “batch weighing systems” will help eliminate some confusion in the marketplace and will aid field officials in making appropriate decisions on the classification of devices they encounter.

Some states evaluate the weighing systems used in the determination of the final quantity delivered by a batch weighing system even though the final product is delivered in a different unit of measure. Testing the weighing elements provides a reasonable assurance of the accuracy of the final product without having to measure the actual cubic yards (in the case of concrete) or counting the seeds (in the case of the seed treatment systems).

Just as the concrete consumer is only interested in the cubic yards of concrete received, the agricultural consumer is actually interested in the count of the seeds received, not the weight. Modern equipment plants seeds by population per acre based on count and not by weight.

In 1985, the Specifications and Tolerances Committee, in its final report, reminded the Conference that the Automatic Bulk Weighing Systems Code does not apply to batching systems, for which the Scales Code applies.

The USDA affirms that when seed is treated it is no longer considered “grain,” and there is a separate definition for treated seed.:

**2015 NCWM Interim Meeting:**

The Committee agreed to group Agenda Items 320-1, 324-1, 330-1, and 360-1 together since these items are related and announced that comments on all four items would be taken together during the Open Hearings. The Committee agreed to Withdraw these items in consideration of the comments and analysis that were provided. Refer to Agenda Item 320-1 for a summary of the comments provided concerning these four items and the reasons why they were Withdrawn.

**Regional Association Meetings:**

**CWMA 2014 Interim Meeting:** An industry representative suggested this item be moved forward as a Voting item. Regulatory officials agreed that the item has merit, but would like to include a definition for “batch scale.” It was noted that there is a definition for “batch meter.” The CWMA forwarded the item to the NCWM, recommending it as a Voting item. The submitter plans to add references to Sections 2.20, 2.22, and 3.30.

**Annual 2014 Meeting:** The SWMA did not hear any comments in opposition to this item and recommended merging Items 320-1, 324-1, 330-1, and 360-1 since they are all related. Comments were heard for all four of these agenda items at the same time. The SWMA forward the item to the NCWM, recommending that it be a Voting item.

Additional letters, presentations, and data may have been part of the Committee’s consideration. To review the supporting documentation, please refer to the *Report of the 99<sup>th</sup> National Conference on Weights and Measures* (SP1193, 2014).

**360-2 D Appendix D – Definitions: calibration parameter and multi-point calibrated device.****Source:**

NCWM Multi-Point Calibration Group (MPCG) (2015)

**Purpose:**

Update the definitions in NIST Handbook 44, Appendix D to reflect advances in device calibration technology.

**Item Under Consideration:**

Amend NIST Handbook 44, Appendix D – Definitions as follows:

**calibration parameter.** – Any adjustable parameter that can affect measurement or performance accuracy and, due to its nature, needs to be updated on an ongoing basis to maintain device accuracy, e.g., span adjustments, linearization factors, and coarse zero adjustments. [2.20, 2.21, 2.24, 3.30, 3.31, 3.32, 3.34, 3.35, 3.37, 5.56(a)]

**Background/Discussion:**

The Committee was asked to consider the following definitions for “calibration parameter” and “multi-point calibrated device.”

**calibration parameter.** – Any adjustable parameter that can affect measurement or performance accuracy and, due to its nature, needs to be updated on an ongoing basis to maintain device accuracy, e.g., span adjustments, linearization factors, and coarse zero adjustments. [2.20, 2.21, 2.24, 3.30, 3.31, 3.32, 3.34, 3.35, 3.37, 5.56(a)]

**multi-point calibrated device. – A device equipped with means to electronically program linearization factors at multiple measurement points.**

**Calibration parameter.** – In 2006, the term “calibration parameter” was added in Sections 3.31., 3.32., 3.34., and 3.35.; these sections now need to be added to the reference string in the definition of “calibration parameter”

**Multi-point calibrated device.** – New technology makes it possible to use linearization factors to optimize accuracy at multiple measurement points on devices such as meters, weighing devices, and other devices. This new technology requires a term so that devices capable of being optimized at multiple measurement points can be distinguished from

devices with single point calibration. The term is used in proposals already before the Committee, and if those proposals are adopted, the term should be included in the definitions. Multi-point calibrated devices are increasingly used as commercial scales and meters. Whether or not the current meter proposals are adopted, the Conference will need to have a term to describe these devices.

**2015 NCWM Interim Meeting:**

NCWM 2015 Interim Meeting: Agenda Items 330-3, 331-1, and 360-2 were grouped together and comments taken simultaneously since the Committee considered them related. See Agenda Item 330-3 for a summary of the comments heard on all three of these agenda items.

The Committee agreed this item should move forward as a Developing item based on the comments received and the submitter's recommendation that it remain Developing because additional work is needed.

**2015 NCWM Annual Meeting:**

NCWM 2015 Annual Meeting: The Committee agreed to group together Agenda Items 330-3, 331-1, and 360-2 and take comments on these items simultaneously. Mr. Russ Vires (Mettler-Toledo, LLC) speaking on behalf of the SMA reported that the SMA was opposed to the definition being proposed for "multi-point calibrated device" in Agenda Item 360-2. Ms. Julie Quinn (Minnesota), submitter of all the items in the group recommended Items 330-3 and 331-1 be Withdrawn in their entirety. She also recommended that the Committee delete the definition of "multi-point calibrated device" in this item and maintain its Developing status because further updates to the Handbook 44 Code references beneath the current Handbook 44 definition of "calibration parameter" were planned.

Hearing no comments in support of Agenda Items 330-3 and 331-1 and a recommendation by the submitter to withdraw them, the Committee agreed to withdraw these items. The Committee also agreed to delete the proposed definition of "multi-point calibrated device" from Agenda Item 360-2 and maintain its Developing status to allow the submitter of the item additional time to develop the proposal. This change is reflected in the "Item Under Consideration" above.

**Regional Association Meetings:**

CWMA 2014 Interim Meeting: The CWMA heard a presentation intended to clarify the purpose of this item. The CWMA noted that it believes the item is sufficiently developed and forwarded the item to the NCWM, recommending it as a Voting item. During the 2015 CWMA Annual Meeting, the submitter of the item indicated that the item was still being developed. Mr. Lou Straub, speaking on behalf of the SMA noted that the SMA opposes the current definition, but supports the continued development of this item. The CWMA agreed to recommend this item move forward as a Developing item.

WWMA 2014 Annual Meeting: Testimony was presented at the 2014 WWMA Annual Meeting by a member of the Multi-Point Calibration Group, stating that the item is fully developed and ready to be a Voting item. No opposition was heard during the WWMA Open Hearings. The WWMA agreed that the item was sufficiently developed and agreed to forward the item to NCWM, recommending that it be a Voting item.

SWMA 2014 Annual Meeting: The SWMA S&T Committee recommended the item be withdrawn based on concerns that, if adopted, it would result in extensive additional work required by inspectors; increased downtime for businesses; questionable gain when compared to existing tolerances; and result in the approval of devices for each product type. The Committee noted it doesn't believe the Handbooks are the proper place for examples. Based on the Committee's recommendation, the SWMA did not forward this item to the NCWM; recommending instead, that it be withdrawn.

NEWMA 2014 Interim Meeting: NEWMA combined Agenda Items 330-3, 331-1, and 360-2 as one agenda item. NEWMA reported it believes the item has merit but required more information before any further judgment could be made on it. NEWMA forwarded the item to the NCWM and recommended it as an Information item. NEWMA agreed to combine Agenda Items 360-2, 330-3, and 331-1 at its 2015 Annual Meeting. The SMA opposed the current proposed definition of "multi-point calibrated device," but noted it looked forward to further changes by the WG. NEWMA agreed to recommend this item move forward as a Developing item as the WG amends language in the proposal.

Additional letters, presentations, and data may have been part of the Committee's consideration. To review the supporting documentation, please refer to the *Report of the 99<sup>th</sup> National Conference on Weights and Measures* (SP1193, 2014).

### 360-3 VC Appendix D – Definitions, point-of-sale-system.

(This item was Adopted.)

**Source:**

NIST USNWG on Taximeters (2015)

**Purpose:**

Clarify the term “point-of-sale system” by providing a more detailed definition in NIST Handbook 44, Appendix D.

**Item Under Consideration:**

Amend NIST Handbook 44, Appendix D – Definitions as follows:

**point-of-sale system.** – An assembly of elements including a weighing or measuring element, an indicating element, and a recording element (and may also be equipped with a “scanner”) used to complete a direct sales transaction. **The system components, when operated together must be capable of the following:**

1. **determining the weight or measure of a product or service offered;**
2. **calculating a charge for the product or service based on the weight or measure and an established price/rate structure;**
3. **determining a total cost that includes all associated charges involved with the transaction; and**
4. **providing a sales receipt.**

**(Amended 20XX)**

**Background/Discussion:**

Stand-alone type of devices is becoming less prevalent in weighing and measuring applications and are evolving into more sophisticated weighing and measuring *systems*. Many different types of devices are now being connected to other components to create systems that are capable of performing all functions required to conduct a complete transaction.

While this proposed amendment does not remove any of the elements listed as *required* components in the existing definition for a POS, the USNWG on Taximeters agreed that the use of the wording “and may also be equipped with a scanner” in the existing definition is archaic, unnecessary, and a specific reference to small capacity weighing systems and, therefore, should be removed.

The USNWG on Taximeters could not agree upon the terms of classifying various assortments of components as point-of-sale systems (POS) when they are installed in taxis due to the type of components that comprise those systems when compared to the current definition of POS. The difficulty was largely due to the existing definition's description of a POS as being a collection of specific pieces of hardware rather than placing more emphasis on what functions are performed when the system's components operate as a system.

The current NIST Handbook 44, Taximeters Code provides an option for, but does not require that a taximeter be capable of issuing a printed receipt. Because of this, some taximeter systems (that do not include a recording element) would not meet the existing definition of a POS. A taximeter may, however, be connected to a sophisticated indicating element referred to as a passenger information monitor (PIM) located in the passenger's area that can be capable of displaying an itemized account of the transaction and may also provide a means to complete the transaction via integral credit card reader. Even though this arrangement did not include a recording element, it was considered by some of

the USNWG to constitute a POS. According to the definition, the taximeter and indicating element with a credit card reader as described above would not be considered to be a POS. This proposal would clarify that only when a system of interconnected components is capable of performing all of the functions listed in the amended definition, is it appropriate for that system to be defined as a POS.

The WG agreed that a POS should be capable of performing at a minimum, the four basic functions listed in the proposal. Rather than describing the hardware components of a POS, the USNWG's proposed method of defining the POS was considered to be more generic and more readily applied to all types of weighing and measuring systems irrespective of the various components that are included within the system.

**2015 NCWM Interim Meeting:**

NCWM 2015 Interim Meeting: The Committee heard no comments on this item. The Committee agreed to replace the language in the original proposal (shown in the box below) with that recommended by the SWMA as shown in "Item Under Consideration" and recommend the item for Vote at the July 2015 NCWM Annual Meeting.

**Original Proposal:**

Amend NIST Handbook 44, Appendix D – Definitions as follows:

**point-of-sale system.** – An assembly of interactive elements including a weighing or measuring element, an indicating element, and a recording element (~~and may also be equipped with a "scanner"~~) used to complete a direct sales transaction. The system components, when operated together must be capable of the following:

1. determining the weight or measure of a product or service offered;
2. calculating a charge for the product or service based on the weight or measure and an established price/rate structure;
3. determining a total cost that includes all associated charges involved with the transaction;
4. providing a sales receipt.

(Amended 20XX)

**2015 NCWM Annual Meeting:**

NCWM 2015 Annual Meeting: The Committee agreed to group together Agenda Items 354-1 through 354-5 and 360-3 and take comments simultaneously on these six items. See Agenda Item 354-1 for the summary of comments provided on these items.

**Regional Association Meetings:**

CWMA 2014 Interim Meeting: The CWMA did not receive comments on this item. The CWMA S&T Committee noted that the item has been under development for two years by the NIST USNWG on Taximeters. The CWMA indicated it believes the item is sufficiently developed and forwarded the item to the NCWM, recommending it as a Voting item.

NEWMA 2015 Annual Meeting: At the Open Hearings, Mr. Lou Straub (Fairbanks Scales, Inc.) speaking on behalf of the SMA supported the item, as did Ms. Fran Elson-Houston (Ohio). The CWMA agreed to recommend the item move forward for Vote.

WWMA 2014 Annual Meeting: During the Open Hearings at the 2014 WWMA Annual Meeting, a member of the USNWG on Taxi Meters reported this item has been in development for three years and is ready to be a Voting item. Further, he stressed that it is imperative that these changes be adopted to ensure the weights and measures community stay current with today's environment. No opposition to this item was presented. The WWMA recognizes the amount of work that has been done on this item and agrees that it is developed. The WWMA forwarded the item to the NCWM and recommended that it be a Voting item.

SWMA 2014 Annual Meeting: The SWMA reported it supports the work of the USNWG on Taximeters and no comments were heard in opposition of this item. The SWMA suggested reversal of the proposed changes in the main paragraph of the definition noting that proposed changes in this section may have unintended consequences for other Sectors. The SWMA forwarded the item to the NCWM and recommended it as a Voting item as amended below:

**point-of-sale system.** – An assembly of elements including a weighing or measuring element, an indicating element, and a recording element (and may also be equipped with a “scanner”) used to complete a direct sales transaction. **The system components, when operated together must be capable of the following:**

- 1. determining the weight or measure of a product or service offered;**
- 2. calculating a charge for the product or service based on the weight or measure and an established price/rate structure;**
- 3. determining a total cost that includes all associated charges involved with the transaction; and**
- 4. providing a sales receipt.**

**(Amended 20XX)**

NEWMA 2014 Interim Meeting: NEWMA heard support for this item from industry and regulators. NEWMA agreed to recommend the item be forwarded to the NCWM as a Voting item. At NEWMA’s 2015 Annual Meeting, the SMA supported this item. NEWMA recommended the item move forward as a Voting item.

Additional letters, presentations, and data may have been part of the Committee’s consideration. To review the supporting documentation, please refer to the *Report of the 99<sup>th</sup> National Conference on Weights and Measures* (SP1193, 2014).

### **360-4 D Appendix D – Definitions: Remote Configuration Capability**

**Source:**

NTEP Grain Analyzer Sector (2013)

**Purpose:**

Expand the scope of definition to cover instances where the “other device,” as noted in the current definition, may be necessary to the operation of the weighing or measuring device or which may be considered a permanent part of that device.

**Item Under Consideration:**

This item is under development. Comments and inquiries may be directed to NIST Office of Weights and Measures.

A proposal to modify the definition for “remote configuration capability” as follows is under consideration:

**remote configuration capability.** – The ability to adjust a weighing or measuring device or change its sealable parameters from or through some other device that ~~is not may or may not~~ **is** itself ~~be~~ necessary to the operation of the weighing or measuring device or ~~is not may or may not be~~ a permanent part of that device. [2.20, 2.21, 2.24, 3.30, 3.37, 5.56(a)]

(Added 1993) **(Amended 20XX)**

**Background/Discussion:**

Removable digital storage devices can be used in GMMs as either data transfer devices that are not necessary to the operation of the GMM or as data storage devices which are necessary to the operation of the GMM. If removable, data storage devices are necessary to the operation of the device, they are not covered by the current definition of “remote configuration capability.”

A USB flash drive is most likely to be used as a data transfer device. In a typical data transfer application, the USB flash drive is first connected to a computer with access to the GMM manufacturer's website to download the latest grain calibrations that are then stored in the USB flash drive. The USB flash drive is removed from the computer and plugged into a USB port on the GMM. The GMM is put into remote configuration mode to copy the new grain calibration data into the GMM's internal memory. When the GMM has been returned to normal operating (measuring) mode, the USB flash drive can be removed from the GMM.

Although a Secure Digital (SD) memory card could also be used as a data transfer device it is more likely to be used as a data storage device. In a typical "data storage device" application, the SD memory card stores the grain calibrations used on the GMM. The SD memory card must be plugged into an SD memory card connector on a GMM circuit card for the GMM to operate in measuring mode. To install new grain calibrations, the GMM must be turned "off" or put into a mode in which the SD memory card can be safely removed. The SD memory card can either be replaced with an SD memory card that has been programmed with the new grain calibrations or the original SD memory card can be re-programmed with the new grain calibrations in much the same way as that described in the preceding paragraph to copy new grain calibrations into a USB flash drive. In either case, the SD memory card containing the new calibrations must be installed in the GMM for the GMM to operate in measuring mode. In that regard, the SD memory card (although removable) can be considered a permanent part of the GMM in that the GMM cannot operate without it.

**Note:** In the above example the SD memory card could be any removable flash memory card such as the Secure Digital Standard-Capacity; the Secure Digital High-Capacity; the Secure Digital Extended-Capacity; and the Secure Digital Input/Output, which combines input/output functions with data storage. These come in three form factors: the original size, the mini size, and the micro size. A Memory Stick is a removable flash memory card format, launched by Sony in 1998, and is also used in general to describe the whole family of Memory Sticks. In addition to the original Memory Stick, this family includes the Memory Stick PRO; the Memory Stick Duo; the Memory Stick PRO Duo; the Memory Stick Micro; and the Memory Stick PRO-HG.

At its 2011 Grain Analyzer Sector Meeting the Sector agreed by consensus that the following changes to Table S.2.5. of NIST Handbook 44, Section 5.56.(a) should be forwarded to the S&T Committee for consideration:

- Add a note to Table S.2.5. to recognize the expanded scope of remote capability.
- Delete "remotely" from the second paragraph of Category 3 requirements that begins, "When accessed remotely ..." to make it clear that the requirements of Category 3 apply whether accessed manually using the keyboard or accessed by remote means.
- Add the modified second paragraph of Category 3 requirements to Categories 3a and 3b to make it clear that these requirements apply to all the subcategories of Category 3.

Because a change to the definition of "remote configuration capability" will apply to other device types, NIST, OWM recommended the changes to Table S.2.5. approved by the Sector in 2011 be separated into two independent proposals. One proposal would deal with the changes to Category 3 and its subcategories. The second would recommend a modification of the definition of "remote configuration capability" appearing in Appendix D of NIST Handbook 44 to recognize the expanded scope of remote capability; this proposal would be an alternative to adding a note to the bottom of Table S.2.5. to expand the definition for remote configuration for grain moisture meters (as shown in this proposal).

At its 2012 Meeting, the Grain Analyzer Sector agreed to separate its original proposal into two separate proposals and agreed to forward this proposal to change the definition of "remote configuration capability" to the S&T Committee for consideration. Also see the August 2012 NTEP Grain Analyzer Sector Summary, Item 5.

See the Committee's 2013 and 2014 Final Reports for additional background information and to review the different proposals considered by the Committee to address security of equipment, the metrological parameters of which can be changed by use of some form of removable digital storage device.

**2015 NCWM Interim Meeting:**

NCWM 2015 Interim Meeting: At the S&T Open Hearings, Ms. Tina Butcher (NIST, OWM) requested that the Committee reassign this item to OWM noting that the issue identified by the Grain Analyzer Sector had not been resolved. Ms. Butcher noted that a gap still exists concerning the sealing of equipment in which the sealable parameters of that equipment can be changed by use of a removable digital storage device. She stated that members of NIST, OWM's Legal Metrology Devices Program (LMDP) have agreed to take up this issue after the 2015 Interim Meeting in hopes of being able to develop a proposal that addresses the issue and be able to report on its progress at the next NCWM Conference.

Mr. Michael Keilty (Endress + Hauser Flowtec AG USA) stated he too would be willing to work with OWM on a proposal to address this issue.

The SMA commented that it looks forward to further clarification of this item.

The Committee agreed to reassign this item to OWM for additional development based on NIST, OWM's assessment there remains an unresolved issue involving the sealing of equipment using removable digital storage devices.

**2015 NCWM Annual Meeting:**

NCWM 2015 Annual Meeting: Ms. Tina Butcher (OWM) provided an update to the Committee on OWM's progress in developing this item. Ms. Butcher noted that OWM's Legal Metrology Devices Program (LMDP) had met several times since the 2015 Interim Meeting to work on this issue. Rather than attempting to modify current sealing requirements, which never envisioned this method of adjustment, the LMDP proposes creating a separate set of sealing requirements for this technology. Members of the LMDP developed a draft General Code paragraph they believe will address the sealing of devices using this technology to make adjustments. The LMDP requests the following draft General Code paragraph be included in this item to begin generating feedback to assist in further development of this item:

**G-S.8.2. Devices Adjusted Using Removable Digital Storage Device. – For devices in which the configuration or calibration parameters can be changed by use of a removable digital storage device, such as a secure digital (SD) card, USB flash drive, etc., security shall be provided by use of an event logger in the device. The event logger shall include an event counter (000 to 999), the parameter ID, the date and time of the change, and the new value of the parameter. A printed copy of the information must be available on demand through the device or through another on-site device. In addition to providing a printed copy of the information, the information may be made available electronically. The event logger shall have a capacity to retain records equal to 10 times the number of sealable parameters in the device, but not more than 1000 records are required. (Note: Does not require 1000 changes to be stored for each parameter.)**

Ms. Butcher also noted that OWM plans to propose modifications to a number of the individual device codes in NIST Handbook 44 to reference the new General Code sealing requirement. The following draft example requirement was developed by the LMDP and included in NIST OWM's written analysis of this item to provide an indication of how some of the device codes in NIST Handbook 44 will need to be amended that this type of sealing can be addressed:

Proposed changes to Scales Code paragraph S.1.11. Provision for Sealing:



**S.1.11. Provision for Sealing.**

**S.1.11.1. Devices Adjusted Using a Removable Digital Storage Device. – For those devices adjusted using a removable digital storage device, G-S.8.2. applies.**

**S.1.11.2. All Other Devices. – Except on Class I scales and devices specified in S.1.11.1. the following provisions for sealing applies:**

- (a) Provision shall be made for applying a security seal in a manner that requires the security seal to be broken before an adjustment can be made to any component affecting the performance of an electronic device.  
[Nonretroactive as of January 1, 1979]
- (b) A device shall be designed with provision(s) for applying a security seal that must be broken, or for using other approved means of providing security (e.g., data change audit trail available at the time of inspection), before any change that detrimentally affects the metrological integrity of the device can be made to any electronic mechanism.  
[Nonretroactive as of January 1, 1990]
- (c) Audit trails shall use the format set forth in Table S.1.11.  
[Nonretroactive as of January 1, 1995]

A device may be fitted with an automatic or a semi-automatic calibration mechanism. This mechanism shall be incorporated inside the device. After sealing, neither the mechanism nor the calibration process shall facilitate fraud.

(Amended 1989, 1991, and 1993)

As final comment regarding this item, Ms. Butcher indicated that devices using other means to access adjustments would continue to be addressed by current sealing requirements.

**Regional Association Meetings:**

Interim 2014 Meeting: The CWMA did not receive any comments on this item and believes the item is sufficiently developed. The CWMA recommended that the item be a Voting item on the NCWM Agenda. During the 2015 CWMA Annual Meeting, the SMA reported that it looks forward to the further clarification of this item, yet it has concerns about changing metrological parameters without proper re-sealing. The CWMA agreed to recommend the item move forward as a Developing item, noting that it supported the continued development of this item.

WWMA 2014 Annual Meeting: During Open Hearings at Annual Meeting, an industry representative questioned whether or not this item would affect definitions for other device types. An NCWM representative expressed the opinion that it does affect other devices. The WWMA recommended that this item remain as a Developing item to allow additional input and consideration.

SWMA 2014 Annual Meeting: The SWMA recommended that this item be withdrawn, noting it believes this item is not necessary and the existing definition in Appendix D of NIST Handbook 44 is adequate.

NEWMA 2014 Interim Meeting: NEWMA recommended this item be withdrawn, noting it believes the existing definition in Appendix D of NIST Handbook 44 is adequate.

NEWMA 2015 Annual Meeting: No comments were received on this item. NEWMA agreed to recommend the item move forward as a Developing item as OWM continues its work on the proposal.

Additional letters, presentations, and data may have been part of the Committee's consideration. To review the supporting documentation, please refer to the *Report of the 99<sup>th</sup> National Conference on Weights and Measures* (SP1193, 2014).

**360-5 VC Electric Vehicle Fueling and Submetering**

(This item was adopted.)

**Source:**

Submitted by California Department of Food and Agriculture Division of Measurement Standards and developed by the USNWG on Electric Vehicle Fueling Systems (2014)

**Purpose:**

Keep the weights and measures community apprised of work to develop standards for Electric Vehicle Fueling and Submetering (EVF&S) and to encourage their participation in this work.

**Item Under Consideration:**

The following changes are proposed to NIST Handbook 44:

Adopt the proposed new code for Electric Vehicle Fueling Systems shown in Appendix H as a tentative code in NIST Handbook 44.

Adopt the proposed modifications to Section 5.55. Timing Devices Code shown in Appendix I.

The USNWG for Electric Vehicle Fueling and Submetering has developed a draft code including proposed specifications, tolerances, and other technical requirements for Electric Vehicle Fueling Systems for addition to NIST Handbook 44. This draft is found in Appendix H. This draft replaces earlier versions of the draft code that were circulated for comment (and included in the Committee's 2014 Annual Report).

The USNWG also developed proposed changes to NIST Handbook 44, Section 5.55. Timing Devices Code shown in Appendix I. These proposed changes are intended to address timing mechanisms found on some electric vehicle recharging systems that are used to determine charges for services (e.g., parking) in addition to the charges for electrical energy.

The appendices referenced above reflect those versions of the USNWG's proposals which were circulated to the regional associations in Fall 2014 and include additional updates agreed to by the Committee at the July 2015 Annual Meeting. The latter changes are described in more detail under the heading of "2015 NCWM Annual Meeting" below.

**Background/Discussion:**

In 2013, the NCWM adopted a uniform method of sale for retail electrical energy sold as a vehicle fuel. Adding specifications, tolerances, and other technical requirements for equipment that measures electricity as a motor fuel are necessary to provide consumer confidence that measurement of electricity is accurate and that there is sufficient information for the selection of charging equipment, (Levels I, II, and III), and price to pay.

The U.S. National Work Group on Measuring Systems for Electric Vehicle Fueling and Submetering (USNWG EVF&S) discussed a number of challenges to field inspection and testing of EVSE systems. Utility companies and at least one U.S. weights and measures jurisdiction have established test procedures and test equipment specifications for utility-type and submetering electrical energy metering applications.

The USNWG EVF&S was formed to develop proposed requirements for commercial electricity-measuring devices (including those used to measure and sell electricity commercially delivered as vehicle fuel and those used in submetering electricity at residential and business locations) and to ensure that the prescribed methodologies and standards facilitate measurements that are traceable to the International System of Units (SI).

The "West Coast Electric Highway" is a project with an extensive network of electric vehicle DC fast charging stations located every 25 to 50 miles along Interstate 5 and other major roadways in the Pacific Northwest. In California alone, there are currently 1387 electric charging stations and over and over one million plug-in electric vehicles (PEV) are projected to be on California roads by 2020. The development of standards for PEV charging equipment is needed to provide consumers with fueling experiences and expectations similar to those at traditional gasoline dispensers.

Additionally, these standards, once they are developed and adopted, will be used to provide training and education to weights and measures officials about testing and regulating these devices, and support uniform standards and enforcement of these standards throughout the United States.

Additional background information, including updates on the progress associated with this item can be found in the Committee's 2014 Final Report.

Following the 2014 Annual Meeting, the USNWG developed a revised draft code for Electric Vehicle Fueling Systems to replace earlier drafts of the proposed code. The USNWG also developed proposed changes to NIST Handbook 44, Section 5.55. Timing Devices Code to address timing mechanisms found on some electric vehicle recharging systems used to determine charges for services (e.g., parking) in addition to the charges for electrical energy. The USNWG submitted these proposed changes to the regional weights and measures associations and the NCWM for consideration. The submitter has requested that these documents replace earlier proposals in the Item Under Consideration.

#### **2015 NCWM Interim Meeting:**

NCWM 2015 Interim Meeting: At the Open Hearings the Committee received a request from the USNWG to replace the previous versions of the proposed NIST Handbook 44, Tentative Code for Electric Vehicle Fueling Systems and the proposed changes to NIST Handbook 44, Section 5.55. Timing Devices Code with versions of these proposals that were circulated to the regional weights and measures association in fall 2014. The Committee heard comments from officials and industry alike that the Tentative Code was ready for adoption as a tentative code in NIST Handbook 44 as were the proposed changes to the Timing Devices Code. Consequently, the Committee agreed to recommend this item for Vote at the July 2015 NCWM Annual Meeting.

#### **2015 NCWM Annual Meeting:**

NCWM 2015 Annual Meeting: At the Open Hearings, several officials and industry members voiced support of adopting the Electric Vehicle Fueling Systems Code as a tentative code. There were no comments heard in opposition. The Committee acknowledged receipt of a letter from the USNWG on EVSE recommending the following changes to the draft code appearing in 2015 NCWM Publication 16, S&T Agenda Appendix H as follows:

1. Correct the spelling of the word requirements in proposed new paragraph S.2.5.1. as follows:

**S.2.5.1. Money-Value Divisions Digital.** – An EVSE with digital indications shall comply with the requirements of . . . based on quantities not exceeding 0.5 MJ or 0.1 kWh.

2. Clarify the record of the transaction format may be made available “either in printed or electronic” format in the first sentence of corresponding Paragraphs S.2.6. and UR.3.3., delete the redundant information about the format that also appears in the last paragraph of UR.3.3., and give each paragraph the same title EVSE Recorded Representation as follows:

**S.2.6. EVSE Recorded Representations. – a receipt, either printed or electronic, providing the following information shall be available through a built-in or separate element at the completion of all transactions:**

**UR.3.3. ~~Printed Ticket~~ EVSE Recorded Representations. – a receipt, either printed or electronic, providing the following information shall be available at the completion of all transactions: . . .**

- (i) the business location.

**~~For systems equipped with the capability to issue an electronic receipt, the customer may be given the option to receive the receipt electronically (e.g., via cell phone, computer, etc.).~~**

3. Clarify that in paragraph N.5.2.(b) Accuracy Testing; For DC Systems the test load is as determined from the digital communication message from the EVSE to the test standard rather than from a pilot signal as shown below:

(b) For DC systems (see note):

(1) Accuracy test of the EVSE system at a load of not less than 85 % of the maximum deliverable current (MDA) as determined from the ~~pilot signal digital communication message from the DC EVSE to the test standard~~ for a total energy delivered of at least twice the minimum measured quantity (MMQ).

(2) Accuracy test of the EVSE system at a load of not more than 10 % of the maximum deliverable current (MDA) as determined from the ~~pilot signal digital communication message from the DC EVSE to the test standard~~ for a total energy delivered of at least the minimum measured quantity (MMQ).

4. Delete the terms from the definition section of the proposal that apply to electric utility meters but *not* to electric vehicle fueling applications; to include proposed modifications to 15 existing NIST Handbook 44 terms and removing from consideration 23 new terms listed below:

active power, apparent power, balanced load, basic lightning impulse insulation level, burden, central location, connection line impedance, electricity meter, element, form designation, instrument transformer ratio, line service, load service, percent error, point-of-sale system, primary wattour constant, reactive power, revolution equivalent, root mean square, tenant, test block, voltage transformer, and wattour – test constant;

Additionally, the USNWG recommends the following minor modifications to 2015 NCWM Publication 16, S&T Agenda Appendix H:

5. Change the title of proposed new EVSE code to ~~Electricity Measuring Devices~~ Vehicle Fueling Systems- Tentative Code; and
6. Renumber Table S.3.4. Categories of Device and Method of Sealing to Table S.3.3 so that the designation corresponds with related paragraph S.3.3. Provision for Sealing.

During the Committee's work session, the Committee agreed to amend the draft code as requested by the USNWG EVF&S and to recommend the item be presented for a Vote.

#### **Regional Association Meetings:**

**CWMA 2014 Interim Meeting:** The CWMA received comment from a regulatory official who indicated that the Committee continues to develop this item. The CWMA believes this is sufficiently developed and recommended that it be a Voting item. During the 2015 CWMA Annual Meeting, Ms. Carol Hockert (NIST, OWM) reported there is a need to provide a tentative code that can be applied to EVSE. Ms. Julie Quinn (Minnesota) agreed. Ms. Fran Elson-Houston voiced concern regarding potential safety and liability issues with electrical meters. The CWMA agreed to recommend the item move for as a Voting item.

**WWMA 2014 Annual Meeting:** During the Open Hearings of the 2014 WWMA Annual Meeting, several regulators voiced support of this item and stated that it is fully developed and should be a Voting item. The WWMA agrees with this opinion and appreciates the amount of work completed that has been completed. Due to the size of the revision, the tentative code will be posted to the NCWM website as an accompanying document for consideration by the NCWM Specifications and Tolerances Committee along with another document with proposed changes to the Timing Device Code. The WWMA recommended this item as a Voting item.

**SWMA 2014 Annual Meeting:** The Committee commended the work of the USNWG on EVSE and recommended incorporation of the proposed new code for Electric Vehicle Fueling Systems into NIST Handbook 44 as tentative code. The SWMA agreed to recommend that this item move forward for vote.

**NEWMA 2014 Interim Meeting:** NEWMA commended the USNWG on its hard work of this timely item and agreed with members of the USNWG that the tentative code is fully developed. NEWMA recommended that the item be a

Voting item. Hearing only comments in support of adopting the Electric Vehicle Fueling Systems Code as a tentative code and no opposition to the item, NEWMA agreed, at its 2015 Annual Meeting, to recommend this item move forward for vote.

Additional letters, presentations, and data may have been part of the Committee's consideration. To review the supporting documentation, please refer to the *Report of the 99<sup>th</sup> National Conference on Weights and Measures* (SP1193, 2014).

---

Mr. Mahesh Albuquerque, Colorado | Committee Chair  
Ms. Rachelle Miller, Wisconsin | Member  
Ms. Jane Zulkiewicz, Town of Barnstable, Massachusetts | Member  
Dr. Matthew Curran, Florida | Member  
Mr. Ivan Hankins, Iowa | Member  
Mr. Luciano Burtini, Measurement Canada | Canadian Technical Advisor  
Mr. Clark Cooney, NIST, OWM | NIST Technical Advisor  
Mr. Rick Harshman, NIST, OWM | NIST Technical Advisor  
Mr. Darrell Flocken, NCWM | NTEP Technical Advisor

### **Specifications and Tolerances Committee**

## Appendix A

### Item 310-2:

#### G-UR.4.1. Maintenance of Equipment

#### **Background Information Provided by Mr. Henry Oppermann, Technical Director, Seraphin Test Measure Company, A Division of Pemberton Fabricators, Inc.**

To promote a greater understanding and to raise awareness of variables that can affect the test results of meters in retail motor fuel devices, Mr. Oppermann provided the following excerpts from a draft training manual, “Introduction to Liquid Measuring Devices,” prepared for the NIST Office of Weights and Measures. This training material explains various sources of temperature effects on the test results for meters, the magnitude of these potential effects, the critical importance to stabilize the temperatures of the product, meter and standard before conducting a test, and the seasonal effects of temperature on the test results. The magnitude of these potential effects on the test results must be considered when assessing the test results for predominance of errors.

#### **The Effects of Temperature**

The effects on temperature on test results for liquid measuring systems are, by far, the largest effects in the test process. Four ways in which temperature affects test results are:

1. The temperature effect on the capacity of the standard;
2. Temperature changes of the fuel from the meter to the volume standard;
3. The lack of a stable temperature of the product in the dispenser and the test system may mean that the initial test of a meter may not be valid indication of meter accuracy; and
4. Seasonal temperature effects on the meter and the test process.

The last three of these effects are related, but there are unique aspects of each effect and how the effects can or cannot be addressed. Consequently, each effect is discussed separately.

#### **Temperature Effect on the Capacity of the Standard**

Below are correction values for provers of different capacities and temperatures.

### Temperature Corrections for Stainless Steel Standards

5-gal		100-gal		1500-gal	
Temp Range (°F)	Adjust prover reading by (in3)	Temp Range (°F)	Adjust prover reading by (in3)	Temp Range (°F)	Adjust prover reading by (in3)
31.5 to 39.5	- 0.75	31.5 to 39.5	- 15	24.7 to 30.0	- 300
				30.1 to 35.4	- 250
39.6 to 47.7	- 0.5	39.6 to 47.7	- 10	35.5 to 40.9	- 200
				41.0 to 46.3	- 150
47.8 to 55.9	- 0.25	47.8 to 55.9	- 5	46.4 to 51.8	- 100
				51.9 to 57.2	- 50
56.0 to 64.0	0	56.0 to 64.0	0	57.3 to 62.7	0
				62.8 to 68.1	50
64.1 to 72.2	0.25	64.1 to 72.2	5	68.2 to 73.6	100
				73.7 to 79.0	150
72.3 to 80.4	0.5	72.3 to 80.4	10	79.1 to 84.5	200
				84.6 to 89.9	250
80.5 to 88.6	0.75	80.5 to 88.5	15	90.0 to 95.3	300
				95.4 to 100.8	350
88.7 to 96.7	1	88.6 to 96.7	20	100.9 to 104.6	400
96.8 to 104.9	1.5	96.8 to 104.9	25		

### Temperature Change of the Fuel

This section will address the situation when the temperature of the product is **not** stabilized before a test is conducted and show how variations in temperature during a test affects the test results. The apparent seasonal effects on test results will be discussed in the next section. The discussions will focus on RMFD meters when tested with 5-gal standards, because considerable data are available to show how temperature changes in the fuel affect the test results. The effects of temperature changes are more apparent in the test of RMFD meters, because the test draft is relatively small. The temperature effects (due to a lack of temperature stability) observed for 5-gal tests of RMFD meters also apply to tests of larger meters, but the larger test drafts tend to reduce these temperature effects.

The Nebraska and Kansas weights and measures programs conducted nine consecutive tests on one day per week on several dispensers over one-year periods. As a result, tests were performed throughout the year under a wide range of air temperatures. The product temperature changed throughout the year as well. The first six 5-gal tests on each meter were fast-flow tests. The last three tests were slow-flow tests. The Nebraska inspectors took the temperature of the fuel in the prover for the first fast-flow test and for the sixth fast-flow tests. The Kansas inspectors took the temperature of the fuel in the prover for each test draft. The meters were not adjusted during these two studies. There were a couple of instances where meters were adjusted near the end of the one-year test period, but the data after the meters were adjusted were not included in the analysis.

Below is a simple diagram of the main components of the major service station components that can influence the temperature of the gasoline or diesel fuel when the meter in the dispenser is tested for accuracy.

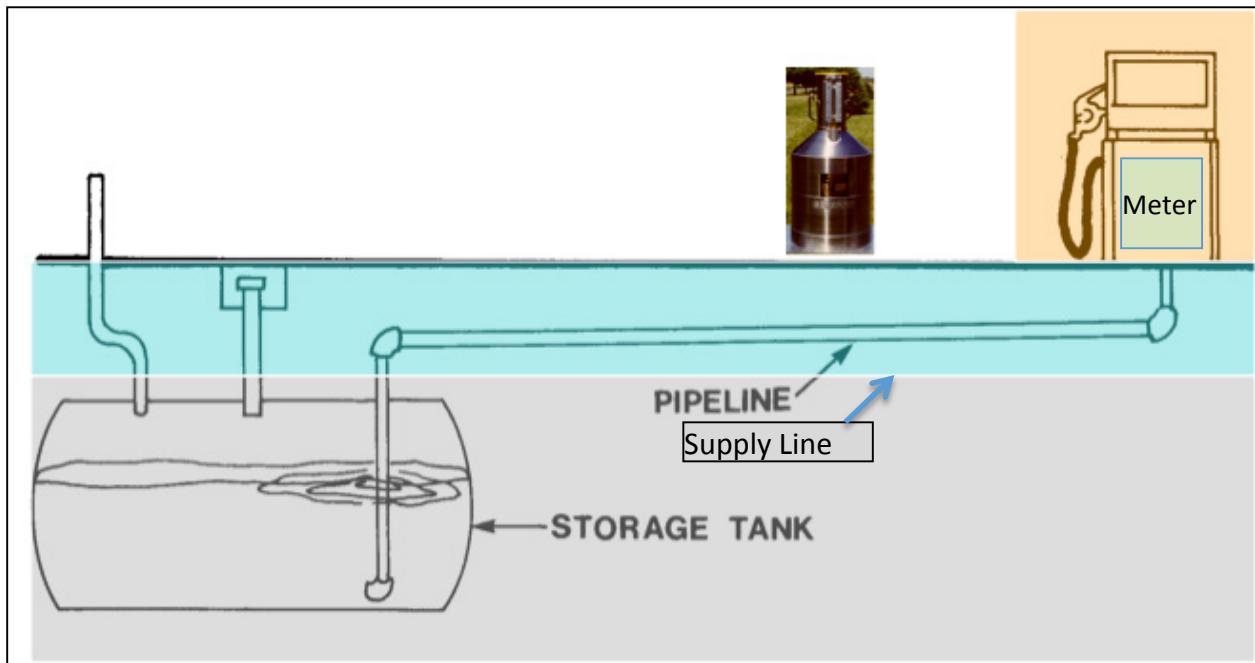

Diagram 6 Modified from the NIST OWM training material for retail motor-fuel devices.

Most service stations have underground storage tanks, but some stations have aboveground storage tanks. There are supply lines that run from the storage tank to each dispenser. The fuel enters the dispenser through the meter, which is usually in the bottom half of the dispenser. The dispenser will have internal piping from the meter, which feeds the fuel to the discharge hose. The fuel is then discharged into the volume standard that is used to test the accuracy of the meter.

It is critical to understand the following:

- The temperature of the fuel in the storage tank is usually different from the temperature of the fuel in the supply lines.
- The temperature of the fuel in the supply lines may then be different from the temperature of the fuel that passes through the meter, since the meter is affected by the temperature of the air inside the dispenser shell.
- After the meter measures the fuel, the fuel passes through the internal piping of the dispenser and the discharge hose before the fuel is delivered into the volume standard.
- The temperature of the volume standard may be different from the temperature of the fuel delivered through the discharge hose.
- The temperature of the fuel in the storage tank and the temperature of the air affect the amount of temperature change that the fuel experiences as it passes through all the components of the delivery system.
- Since gasoline and diesel fuel (and LPG) have rather large coefficients of cubical expansion, small changes in temperature of the fuel from the meter to the standard will



have significant effects on the volume of the fuel that was measured by the meter and the volume of fuel that is ultimately delivered into and measured in the volume standard.

- The amount of temperature change in the fuel is greatly affected by the air temperature around the dispenser and the volume standard and the air temperature inside the dispenser shell. These effects are most noticeable in very warm and very cold weather, that is, when the difference in the temperature of the air and the product are greatest. Furthermore, the time that the dispenser sits idle between deliveries, especially in very warm or very cold weather, affects the extent to which these temperature differences affect the volume of the fuel as it passes through the dispenser into the volume standard.

A 1 °F change in the temperature of 5 gallons of gasoline changes the volume of the gasoline by 0.8 in<sup>3</sup>. For diesel fuel, a 1 °F change in the temperature causes a change of about 0.55 in<sup>3</sup> in a 5-gal test draft. The temperature changes during a 5-gal test draft and between consecutive 5-gal test drafts for RMFDs can be very large, which causes large variations in test results from one test draft to the next consecutive test draft. It is important to verify test results to ensure that the test results are valid, especially when test results are at or near the tolerance limit or when enforcement action is considered for a predominance of errors. It is critical that actions are taken to ensure that temperature changes are reduced as much as possible to comply with the Handbook 44 test notes. These temperature effects are greatest in very warm and very cold weather when the temperatures of the air and the fuel are very different.

When Kansas Weights and Measures conducted their 52-week survey, the inspectors took the temperatures of the fuel in the 5-gal provers for each consecutive test draft. The charts below show the extent to which the temperatures of the fuel change during the test drafts and between test drafts. The changes in temperature during the initial test drafts of meters can be surprisingly large, especially when tests are conducted in very hot and very cold air. Consequently, these temperature changes cause large variations in the test results.

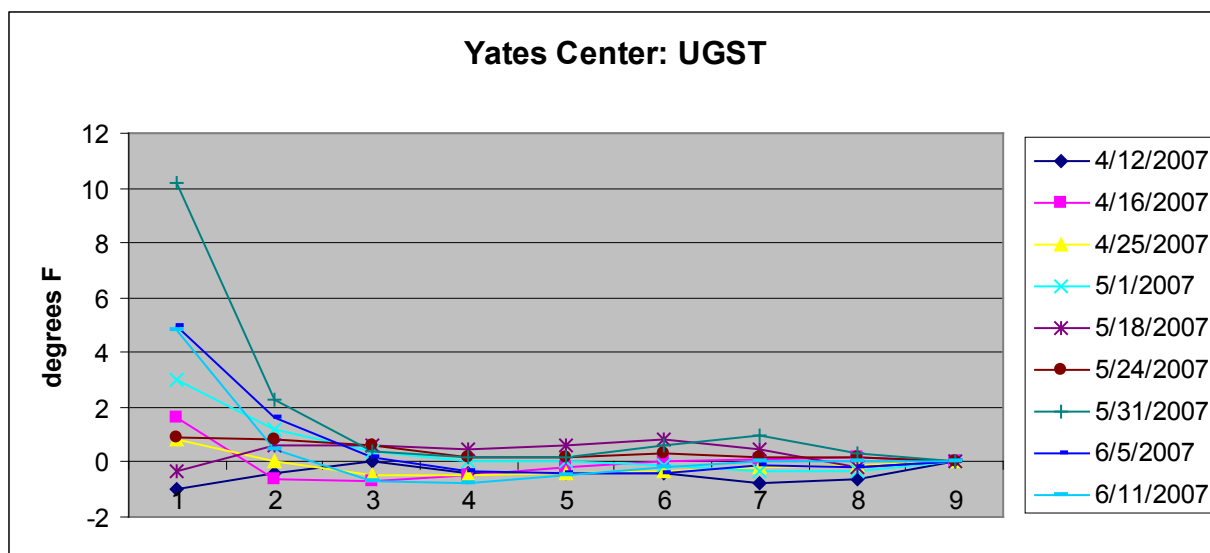

This publication is available free of charge from: <https://doi.org/10.6028/NIST.SP.1210>

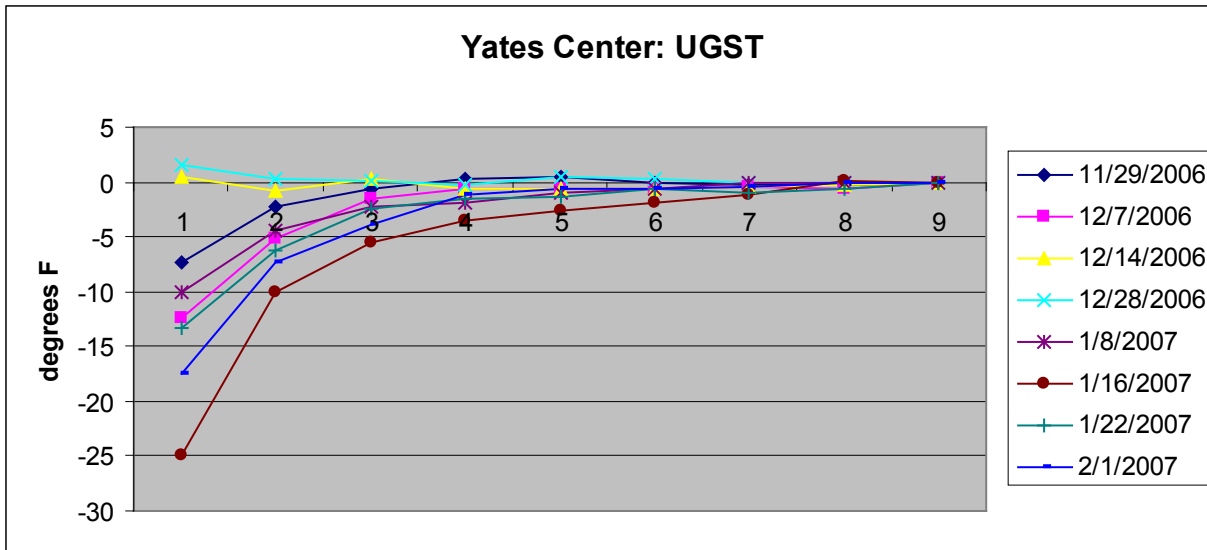

One can see that the temperature changes are greatest for the first test draft in hot and cold weather (based upon the dates when the tests were conducted). If the dispenser has been sitting idle for some time between deliveries, the hot and cold temperatures can cause changes to the temperatures of the meter, the piping in the dispenser, the discharge hose and the fuel inside these components. If the standard has also been sitting idle and is at a temperature significantly different from the temperature of the fuel used in the test, then the temperature of the fuel will change considerably during a delivery. Furthermore, if the dispenser has been idle for a considerable time in hot or cold weather, it may take several 5-gal deliveries to stabilize the temperature of the fuel, the meter, the dispenser piping, the discharge hose and the volume standard before consistent test results are obtained.

The effect of changing temperatures during three consecutive tests can have a large impact on the repeatability of the meter. The chart at the right shows that the lack of temperature stability for the first test of a meter can have a large impact on the repeatability tests of the first three tests of a RMFD meter. However, if the first test draft is excluded, the repeatability performance is much better for the subsequent sets of three tests.

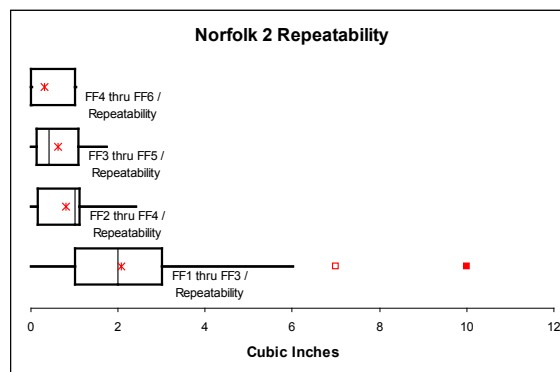

These temperature effects are most observable in 5-gal test drafts used to test RMFD meters, because the sizes of the test drafts are relatively small. When VTMs and loading-rack meters are tested, test drafts must be of volumes equal to at least one minute of the maximum discharge rate of for the meter. Because the sizes of the test drafts are much larger for VTMs and loading-rack meters, the effect of the temperature changes in the first “few” gallons of the test draft are relatively small compared to the total size of the test draft. Consequently, the temperature change on the total volume of the test draft is usually much smaller for large test drafts; however, these relatively small temperature changes can still have a significant effect on the test results. Hence, inspectors must make corrections for any temperature changes

that are observed when the temperature of the fuel can be taken at the meter and when filled prover. Since VTMs usually deliver fuel through a long discharge hose, these temperature differences can be significant. The length of discharge pipe from loading-rack meters to the end of the discharge pipe will vary from installation to installation, so inspectors must be aware of possible changes in the temperature of the fuel temperature from the meter to the prover.

Even if the temperatures of the fuel, the meter, the discharge piping, the discharge hose and the volume standard are stabilized before performing accuracy tests, be aware that when there are significant differences in the temperatures of the fuel and the air during a delivery, the temperature of the fuel can still change as the fuel moves from the meter to the volume standard. If the time periods for and between consecutive tests are consistent, say three consecutive fast-flow tests, the temperatures for the three consecutive tests may be nearly the same. However, it is possible that the temperature of the fuel still changed as it moved from the meter to the volume standard due to the difference in the temperatures of the air and the fuel. Unless an inspector can take the temperature of the liquid at the meter and in the prover, these consistent changes in the temperature of the fuel may not be observable, especially when testing uncompensated meters, since uncompensated meters are not required to have thermometer wells at the meter. It is important that inspectors understand the effects that temperature differences for the air and the fuel can have on test results, especially when there are large differences in the temperature of the air and the fuel.

The box-and-whisker graph is effective to illustrate the variations in the test results of the consecutive tests due to the lack of stabilization of temperature in the tests. The chart at the right shows the results for each of the nine tests conducted on the meter over the course of one year. The width the box and the length of the whiskers indicate the amount of variation in the test results. Obviously, the results of the first test show the greatest variation and the variations are large compared to the maintenance tolerance for the meter. The variations in the test results are much less after the first 5-gal test.

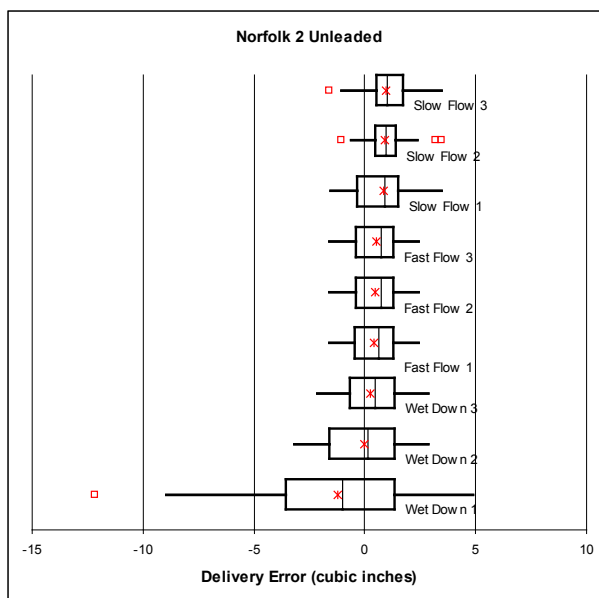

**Recommendation:** It isn't possible to correct for the effects of the lack of temperature stability, so the best course of action is to try to stabilize the temperature of the fuel, the meter, the dispenser piping, the discharge hose and the standard before accuracy tests are conducted. While the best approach is to run a preliminary draft of 5 gal on each meter before conducting an accuracy test, this would significantly increase the time it would take to test RMFD meters at each service station. Hence, the recommendation is that inspectors should repeat any tests that are at or outside (and relatively near the tolerance limit) to verify that the test results are valid and not affected by a lack of temperature stability. Tests should also be repeated when action is considered based on the predominance of errors. The consequences of rejecting meters are much greater than the consequences of passing meters. The inspector should always make the extra effort to ensure that

the results of enforcement tests are valid so that meters are not rejected due to the effects of variables that may have influences the test results.

### Seasonal Temperature Effects

Stabilizing the temperature of the fuel throughout the dispenser and the standard still does not eliminate all of the temperature effects. Differences in test results from summer to winter or, more specifically warmer and colder air temperatures, are still evident. The temperature effect causes the apparent accuracy of the meter to change from summer to winter, even though the meter has not been adjusted.

The chart at the right shows the meter delivery error for the sixth fast-flow test plotted against the air temperature throughout the survey. Although the product temperature was stabilized with five consecutive fast-flow tests before the sixth test, the effect of temperature is still present. The correlation coefficient for the data is 0.82. The difference in delivery errors over the course of the survey has a range of about 4 in<sup>3</sup>. This apparent change in accuracy is probably due (1) in part to the temperature effect on the meter itself and (2) the remainder is due to the temperature effect on the volume of the fuel. **However, not all makes of meters responded the same way as the meter above. (See the chart to the right.) Some meters showed smaller temperature effects, while others showed virtually no temperature effects. There were some meters that actually appeared to deliver less fuel in hot weather than in cold weather.**

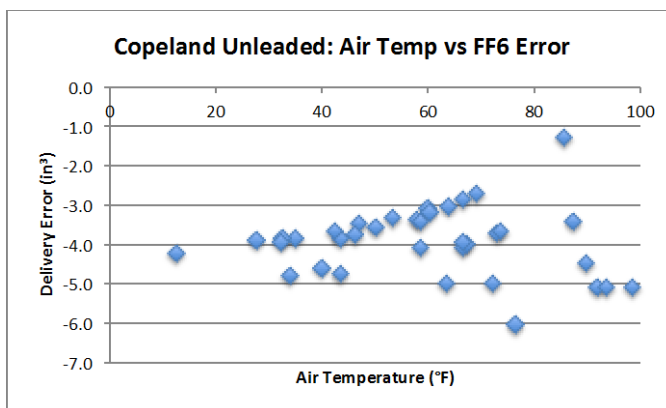
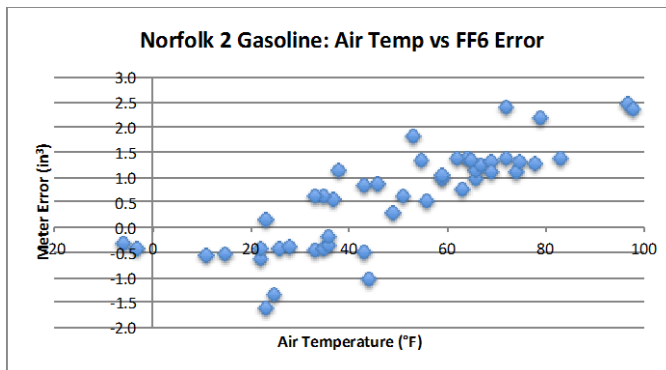

It is important to understand how this remaining temperature effect will affect the test results. If the meter shown in the Norfolk 2 chart above was adjusted to zero error in hot weather, then in cold weather the meter would appear to deliver 3 to 4 in<sup>3</sup> less fuel than in hot weather. Assuming that all of the meters in a single station are of the same model as this one and all of the meters were adjusted to zero error in hot weather, then when tested in cold weather, the test results for all of the meters in the station would appear to under deliver and give the appearance of a predominance of errors in favor of the station. The results of slow-flow tests will be affected to a greater extent than the results of fast-flow tests, because more time is needed to deliver the desired test quantity, so there is more time for the differences in temperature to affect the test results. In this example, these under-delivery errors are not due to a fraudulent action of the part of the service representative during the adjustment of the meter, but a consequence of the temperature effect on the test results.

If all of the meters were adjusted to zero error in cold weather, then all of the meters would appear to deliver more fuel in warm weather. Weights and measures officials must consider the effects of temperature, especially when considering action for a predominance of errors, since the appearance of the predominance of errors may be due to temperature effects and may not be due to fraudulent adjustment on the part of service representative or the station owner.

### Effect of Temperature on Predominance of Errors

The lack of temperature stability and different temperature conditions can bias the test results for one set of tests versus another. The chart below shows the test results (Set 1) for a service company representative who tested 12 regular gasoline meters in a service station (noted as FF1, FF2 and SF). A couple of months later, a weights and measures inspector conducted one fast-flow test on the meters (Set 2). A few days later, the service company representative retested four of the meters to determine the “as found” condition (Set 3).

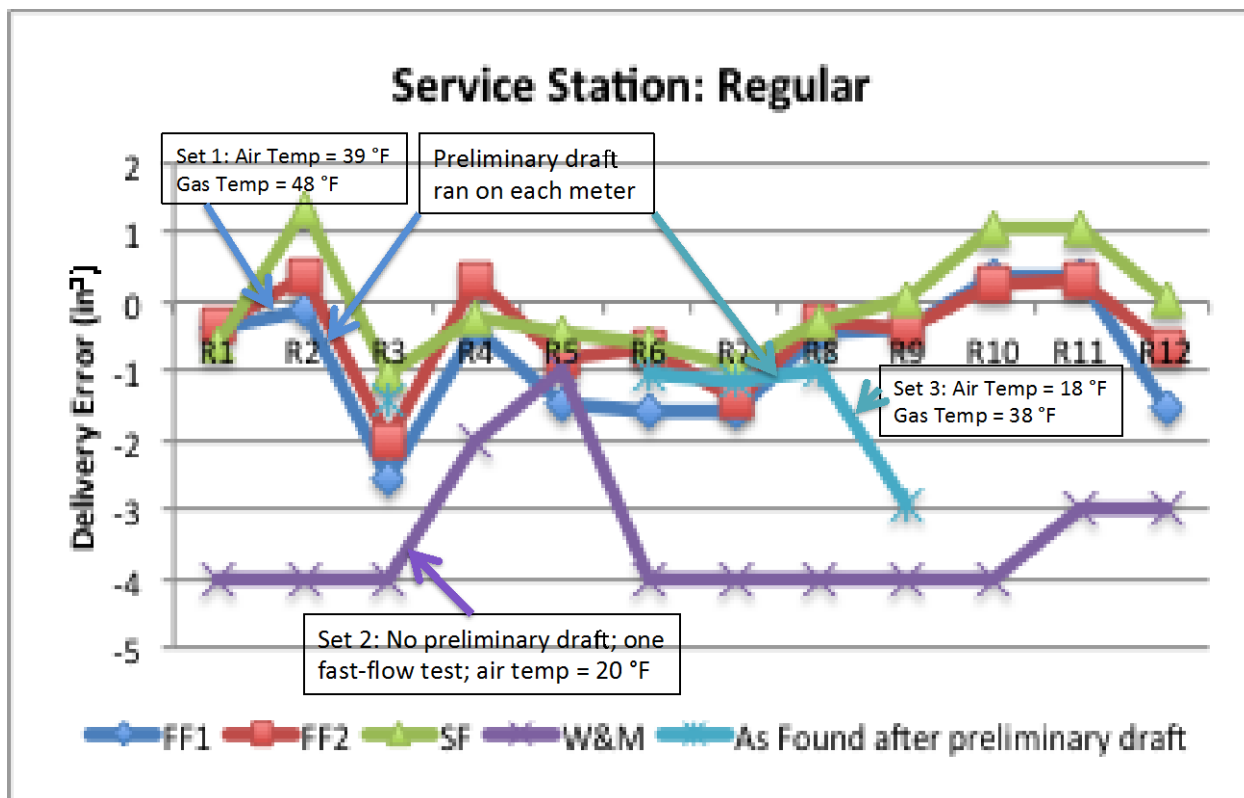

The first set of tests run by a service company consisted of a preliminary test draft on each meter, followed by two fast-flow tests and one slow-flow test. The air temperature was 39 °F and the temperature of the gasoline was 48 °F.

Approximately two months later, the local weights and measures inspector conducted one fast-flow test on each meter and concluded that the meters were delivering predominately short measure. The test results for the weights and measures inspector are shown in the chart above and noted as W&M. No preliminary test drafts were run on the meters. The air temperature was 20 °F. The temperature of the gasoline is not known, but it was probably around 38 °F.

The service company returned a few days after the weights and measures inspector tested the meters and retested four meters to establish the “as found” condition. The air temperature was 18 °F and the temperature of the gasoline was 38 °F. A preliminary draft was run on each meter before a fast-flow test was conducted. The results for three of the four meters were essentially the same as when the service representative tested the meters about two months earlier. One meter delivered about 2.5 in<sup>3</sup> less than two months earlier.

The key aspect of the test results is that the test results for the weights and measures inspector were biased toward under delivery and gave the impression that the meters were delivering short measure gasoline. However, the test results by the weights and measures inspector were affected by temperature and the lack of temperature stability. In fact, the results obtained by the weights and measures inspector were not valid indications of the accuracy of the meters.

These test results are another example that show that the results of the first test of a meter may be invalid when the temperatures of the gasoline, the meter piping inside the dispenser, the dispenser hose and the standard are not stabilized before the meter is tested for accuracy. The results for the service company showed that when a preliminary draft was run on each meter, then the results of the third set of tests were generally consistent with the first set of test results conducted under a different set of test conditions. Since the weights and measures inspector did not stabilize the temperatures of the gasoline, the meter and the standard before running the accuracy tests, the inspector’s test results were biased and gave a false impression that the meters were set predominantly in favor of the seller. This situation illustrates the importance of repeating tests to stabilize temperature and verify test results before rejecting meters for an apparent predominance of errors.

THIS PAGE INTENTIONALLY LEFT BLANK

## Appendix B

### Items 320-1, 324-1, 330-1, and 360-1:

#### 320-1: Scales; 324-1: Belt-Conveyor Scale Systems; 330-1: Liquid Measuring Devices; and 360-1: Appendix D. Definitions

Comments by Henry Oppermann  
Weights and Measures Consulting

#### Topics

POSITION STATEMENT.....	1
DEFINITION OF BATCHING SCALE: ITEM 360-1 .....	1
BATCHING SCALES AND AUTOMATIC BULK WEIGHING SYSTEMS: ITEMS 360-1 AND 320-1 .....	2
SELLING TREATED GRAIN BY THE “SEED UNIT”: ITEM 360-1.....	3
DEFINITION ALLOWS DIFFERENT UNITS OF MEASURE: ITEM 360-1.....	4
NON-AUTOMATIC BATCHING SYSTEMS: ITEM 320-1 .....	4
RETURN TO ZERO TOLERANCE OR SCALE EMPTY TOLERANCE: ITEM 320-1 .....	4
ADDITION TO THE LIQUID MEASURING DEVICES CODE: ITEMS 330-1 AND 360-1 .....	4
ADDITION TO THE AUTOMATIC WEIGHING SYSTEMS CODE: ITEMS 224-1 AND 360-1 .....	4
CONCLUSIONS.....	5
APPENDIX: EXAMPLES OF BATCHING SYSTEMS .....	8

#### Position Statement

This document addresses the four items that are related: 320-1, 324-1, 330-1, and 360-1. The proposals are ill conceived, poorly developed and without merit. The proposed definition in item 360-1 is incorrect, because it does not properly define a batching scale. I encourage the S&T Committee to withdraw these items.

The objective of the proposals is to create a category of scales in the Scales Code for the KSi automatic bulk weighing systems used in the KSi seed treatment process, so that the scales are not classified as automatic bulk weighing systems. Apparently, they want to call the weighing systems “batching scales” so they can circumvent the requirements of the Automatic Bulk Weighing Systems Code, which are needed to ensure accurate weighments.

Furthermore, KSi wants to issue “weigh tickets” in seed units and base the sale of treated seeds in seed units. “Seed units” are not legal units of measurement and should not be used as the basis for commercial transactions.

Even if the NCWM would adopt the proposed definition in 360-1, this will not help KSi, because simply changing what they call their weighing systems does not change how their systems operate. Their scale systems are automatic bulk weighing systems; they are not batching scales.

#### Definition of Batching Scale: Item 360-1

A batching scale weighs two or more materials into a weigh hopper as part of a single weighment, that is, one weighing cycle that starts at zero, goes to a loaded condition by addition two or more materials, and then returns to zero. The proposed definition of a batching scale in item 360-1 has several key points that create problems.

1. The raw material could be a single material. Batching scales weigh two or more materials as part of a batching process.



2. The reference to “predetermined quantities by weight and/or liquid measure” is unclear. What is the purpose of this terminology? Does this mean that every transaction must be by the same predetermined quantity? Can the predetermined quantity vary for each transaction? Are the predetermined quantities based upon specified weights and volumes or may they be set percentages of the weighed product? If this definition is to apply to the KSi systems that automatically weigh multiple drafts of a single commodity in a weigh hopper as part of an automatic bulk weighing system, then how does this definition apply to the last draft of the multiple drafts, which may be a different amount from the previous drafts?
3. The proposed definition addresses a scale that weighs in predetermined quantities, but leaves out the word “automatically.” The KSi scales can weigh some small orders (less than the scale capacity) as single draft and automatically weigh larger orders as multiple drafts. As currently designed, the KSi scales are not required to return to zero before initiating the next weighing cycle. The load and no-load weight values should be recorded, but they are not.
4. The unit of measure for the final product may be different from any of the units of measure for the raw materials. These units are not defined, but they must be legal units of measurement. KSi wants to use “seed units.”

If the S&T Committee believes that a definition of a batching scale is needed, then the definition should be correct and clearly distinguish between batching scales, hopper scales and automatic bulk weighing systems. The following alternate definition of a batching scale is provided for consideration. Clarifying language is included to remove ambiguity regarding different applications for scales and weighing systems.

**Batching scale.** – A batching scale is a scale that weighs two or more commodities or materials into a weigh hopper as part of a single weighment. To clarify, a hopper scale or weighing system that weighs a single commodity or material as a single weighment is not a batching scale. Also, a hopper scale or weighing system that automatically weighs a single commodity or material in multiple drafts (either fixed or variable-sized drafts) for a single transaction is not a batching scale, since these scales or systems are automatic bulk weighing systems and must meet the requirements of the Automatic Bulk Weighing Systems Code.

### Batching Scales and Automatic Bulk Weighing Systems: Items 360-1 and 320-1

A scale has to weigh two or more materials together or added to the weigh hopper in sequence as part of a weighing process to be a batching scale. Examples are shown below.

#### This is a Batching Scale

<http://www.ktron.com/process-equipment/feeders/technology/gain-in-weight-batching.cfm>

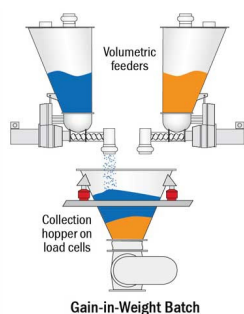

#### Command Alkon Batching System

[http://www.commandalkon.com/wp-content/uploads/2014/06/booklet\\_plantautomation.pdf](http://www.commandalkon.com/wp-content/uploads/2014/06/booklet_plantautomation.pdf)

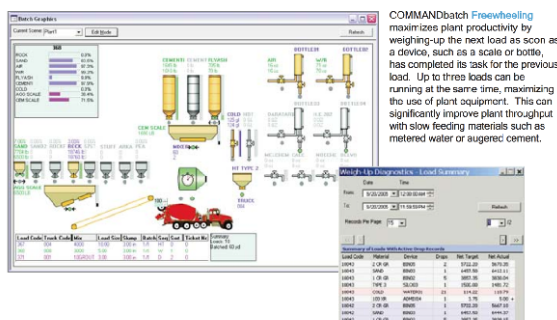

The categorization of scales under Handbook 44 are based upon the weighing application, the manner of operation of the scale and, sometimes, upon the commodity that is weighed. Whatever happens to the commodity after it is weighed is immaterial to the categorization of a scale. For example, if an automatic bulk weighing system is used to weigh grain, the application and the categorization of the scale do not depend on if, after weighing, (1) the grain is then transferred into the hold of a ship for export, (2) the grain is ground for use in a food product, or (3) the grain is treated as seed for planting.

Based on the proposed definition in item 360-1, would the automatic bulk weighing systems (scales) used to weigh grains for export and into the hold in a ship now be called batching scales? Do these scales have to meet the requirements of the Automatic Bulk Weighing Systems Code or do they fall under the Scales Code?

There is a difference between batching **systems** that utilize **batching scales** and batching systems that utilize **hopper scales** dedicated to weighing a single material for an individual transaction. A batching scale weighs multiple materials that are delivered into the weigh hopper as part of a single weighment (i.e., before emptying) based upon a prescribed recipe.

The application section of the Automatic Bulk Weighing Systems Code states the following:

**A.1. General.** – This code applies to automatic bulk weighing systems, that is, **weighing systems adapted to the automatic weighing of a commodity in successive drafts of predetermined amounts automatically recording the no-load and loaded weight values** and accumulating the net weight of each draft. (Emphasis added)

The KSi systems automatically weigh seed grains in successive drafts of predetermined amounts, but they do not record the load and no-load weight values of each draft. For a given customer order, the scales weigh only one seed grain for treatment. They print the accumulated weight of all drafts **with the assumption** that the scale returned to zero for each draft. Actually, they allow the scale to operate automatically for multiple drafts if the scale returns within the “scale empty tolerance” that can be programmed into the controller. Already, based on the described operation, the scales have several violations of the Automatic Bulk Weighing Systems Code. The “scale empty tolerance” feature also violates a requirement in the Scales Code.

KS*i* claims that 30 state weights and measures programs classify their system as a hopper scale and one state program calls it an automatic bulk weighing system. The state that classified it as an automatic bulk weighing system has classified the system correctly. The other states should reexamine the operation of these scales in their jurisdictions and, if those scales automatically weigh multiple drafts of grain for some or all of the transactions, then the states should require these systems to meet the requirements of the automatic bulk weighing systems code.

### **Selling Treated Grain by the “Seed Unit”: Item 360-1**

KS*i* wants to be able to sell **bulk** treated grain in seed units. This is not allowed by the Uniform Weights and Measures Law (UWML) or by the Uniform Regulation for the Method of Sale of Commodities in Handbook 130. The second paragraph in Section 2 of the UWML states, “The definitions of basic units of weight and measure, the tables of weight and measure, and weights and measures equivalents as published by NIST are recognized and shall govern weighing and measuring equipment and transactions in the state.” There isn’t a NIST standard number of seeds per “seed unit” for different grains and never will be.

The Uniform Packaging and Labeling Regulation allows the sale by count of packaged, treated seed for packages with net contents of less than 225 g or 8 oz. The sale by count does not apply to the sale of bulk treated seed.

*Programmable Seed Counts:* Some of the companies using the KSi seed treatment systems sell the treated seed on the basis of seed units. The number of seeds per pound and the number of seeds per unit are programmable through the controller. For transactions based on seed units, the number of seeds per pound and the number of seeds per unit are effectively calibration values and must be sealed. However, the NTEP Certificate says that there are no metrological features in the controller, so it doesn’t have to be sealed. This is a conflict. Either the controllers on the KSi scales installed in the field are not consistent with the “type” that was evaluated by NTEP or the features were not evaluated by NTEP.

*Are they counting scales?* If companies sell treated seed by seed units, are these scales actually counting scales? If they are counting scales, then they should be marked according to Scales Code Table S.6.3.(b) point 13 (below) with the statement, “The counting feature is not legal for trade.” Also, if they are counting scales, then they must meet the requirements for counting scales, utilize proper sampling procedures to determine the seed count per unit of weight, and utilize adequate sample sizes (with appropriate scales) to determine the seed count per unit of weight. The Scales Code recognizes only Class I and Class II scales as counting scales.

13. *A scale designed for a special application rather than general use shall be conspicuously marked with suitable words, visible to the operator and to the customer, restricting its use to that application, e.g., postal scale, prepack scale, weight classifier, etc.\** When a scale is installed with an operational counting feature, the scale shall be marked on both the operator and customer sides with the statement “The counting feature is not legal for trade,” except when a Class I or Class II prescription scale complies with all Handbook 44 requirements applicable to counting features.

Even if you call them counting scales, the scales that automatically weigh multiple drafts to obtain the quantity for the transaction are automatic bulk weighing systems and have to meet the requirements of the Automatic Bulk Weighing Systems Code.

### **Definition Allows Different Units of Measure: Item 360-1**

The proposed definition allows the sale of the product in units of measure different from the units of measure used to weigh the raw material. Suppose that I have one of these systems, can I sell the treated seed by the Gasoline Equivalent Gallon? Tomorrow, can I sell it by the Diesel Equivalent Gallon? What prevents me from doing that? If this definition is adopted, then do I have to use legal units of measurement?

California produces huge amounts of grapes that are used to produce wine. The picked grapes are weighed on platform scales or truck scales. If the NCWM adopts the proposed definition for batching scales, does that mean that the scales used to weigh grapes for wine-making can indicate in bottles of wine? What would prohibit it under this definition? Under the proposed definition, can the scales be considered batching scales, since they are used in one step of the overall wine production process?

### **Non-automatic Batching Systems: Item 320-1**

The proposed definition in item 360-1 is for a batching scale. The proposed change in item 320-1 adds the text “including non-automatic batching systems.” What is a non-automatic batching system? What is the difference between a non-automatic and an automatic batching system? What is the difference between a batching scale and a batching system? Why is this proposed additional text needed, when there are no changes proposed for the Scales Code? What is the objective of this proposed change?

### **Return to Zero Tolerance or Scale Empty Tolerance: Item 320-1**

The scales have a programmable zero empty tolerance feature that is larger than the return-to-zero requirement in Handbook 44. NTEP CC 14-009 for the automatic bulk weighing system controller does not list this feature on the Certificate. Additionally, the CC states that “There are no metrological functions that require a seal.” Either this feature was not brought to the attention of NTEP at the time of the type evaluation or the manufacturer has changed the design of the controller and added a metrological characteristic to the controller. Either way, this feature should not be allowed on a commercial measuring device.

### **Addition to the Liquid Measuring Devices Code: Items 330-1 and 360-1**

Based on the proposed definition in 360-1 and the proposed addition to the LMD Code item 330-1, if a RMFD has one meter for regular and one for premium gasoline and the midgrade is a blend of the two, does that make the RMFD a batching meter?

If a loading rack meter blends the additives into the gasoline at the time that the tank truck is loaded, does the loading rack meter become a batching meter? What is the difference between a loading rack meter and a loading rack batching meter?

Are there different requirements that must be added to the code to apply to batching meters? If not, then why add a statement in the application section of the code for a batching meter when there aren't any special requirements for batching meters?

### **Addition to the Automatic Weighing Systems Code: Items 224-1 and 360-1**

As for Item 324-1, which is the addition to the Automatic Weighing Systems Code, the Code applies to completely different types of scales than the KSi automatic bulk weighing systems. If this change is made and an automatic checkweigher is used in a packaging line for packaging macaroni-and-cheese packages, does the checkweigher

become a macaroni-and-cheese batching scale? If an automatic checkweigher is used in a cheese packaging line, does it become a cheese-batching scale? What is the basis for proposing the addition to the A.1. paragraph? To which types of scales is this proposed addition intended to apply?

## Conclusions

In summary:

- A gain-in-weight batching scale weighs multiple raw materials in the hopper.
- A scale used in a production process is not a batching scale, unless it weighs two or more different materials as a batch.
- Seed treatment is a production process; not a batching process.
- Weighing a single grain for a transaction does not make the scale a batching scale.
- The KSi systems weigh a single grain (seed) for each order, which the industry appears to call a “batch.” Calling the product of the seed treatment process a “batch,” for the purposes of a transaction, does not make the scale a batching scale.
- A scale that automatically weighs multiple drafts of a single grain is an automatic bulk weighing system.

The four items, 320-1, 324-1, 330-1, and 360-1, are ill conceived, poorly developed and without merit. These items should be withdrawn from the S&T Committee Agenda.

If a definition of batching scale is needed, then the following definition is offered for consideration.

**Batching scale.** – A batching scale is a scale that weighs two or more commodities or materials into a weigh hopper as part of a single weighment. To clarify, a hopper scale or weighing system that weighs a single commodity or material as a single weighment is not a batching scale. Also, a hopper scale or weighing system that automatically weighs a single commodity or material in multiple drafts (either fixed or variable-sized drafts) for a single transaction is not a batching scale, since these scales or systems are automatic bulk weighing systems and must meet the requirements of the Automatic Bulk Weighing Systems Code.

## Appendix: Examples of Batching Systems

Web Site References:

<http://www.ktron.com/process-equipment/feeders/technology/batch-feeding.cfm>

<http://www.ktron.com/process-equipment/feeders/technology/gain-in-weight-batching.cfm>

<http://www.ktron.com/process-equipment/feeders/technology/loss-in-weight-batching.cfm>

### Batch Feeding and Weighing Systems

There are two principle batching methods for weighing and feeding bulk materials

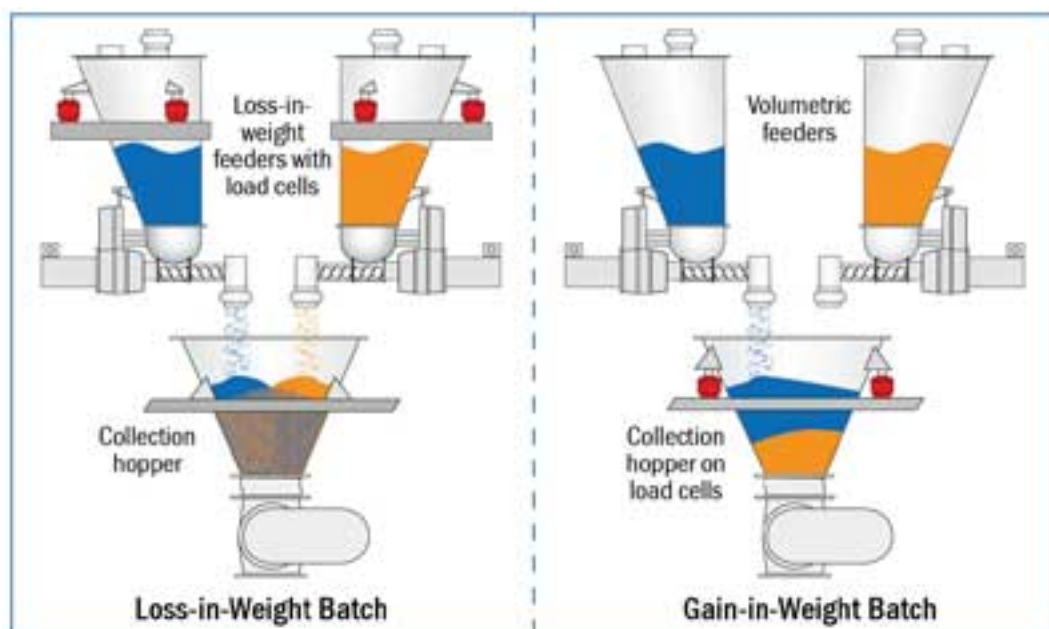

The manufacture of any blended product typically involves the intermediate process steps of transfer and weighing or batching of individual ingredients based upon their weight percentage in a blend. Depending on this percentage, materials are categorized as majors, minors and micros.

A **Gain-in-Weight (GIW) batching station** includes volumetric metering devices, such as screw feeders or valves, that deliver the product to a hopper on load cells. The **Loss-in-Weight (LIW) batching system** employs gravimetric feeding devices, such as loss-in-weight screw or vibratory feeders, which are mounted on individual load cells or scales. In cases where small amounts of micro ingredients are required, both methods may be employed: LIW feeders for the micros and minors, and GIW batchers for the major ingredients.

### Gain-in-Weight Batching Principle

Volumetric feeders are often used in Gain-in-Weight (GIW) applications for controlled batch dispensing and weighing of dry bulk materials. Batching may take place directly into IBCs (Intermediate Bulk Containers), hoppers or drums. Batched ingredients may also be dispensed directly into batch blenders. Where hazardous ingredients are among the batched ingredients, processors need a batching device where ingredients can be easily contained to eliminate any exposure of the product to the operator or to the environment.

In GIW batching the volumetric metering devices sequentially feed multiple ingredients into a collection hopper mounted on load cells. Each feeder delivers approximately 90% of the ingredient weight at high speed, slowing down towards the end of the cycle to deliver the last 10% at a reduced rate (often called “dribble mode”) to ensure higher accuracy.

The GIW controller monitors the weight of each ingredient and signals each volumetric feeder to start, increase or reduce speed, or stop accordingly. Once all the ingredients have been delivered, the batch is complete and the mixture is discharged into the process below.

**Loss-In-Weight Batching Principle**

LIW batching is used when individual ingredients must be weighed more accurately or when the batch cycle times need to be very short. Gravimetric feeders operating in batch mode simultaneously feed multiple ingredients into a collection hopper. Adjustment of the delivery speed (on/off, fast/slow) lies with the LIW feeder controls. Since each feeder has its own dedicated weighing system, the LIW batching system, delivers highly accurate batches for each ingredient.

Once all the ingredients have been delivered, the batch is complete and the mixture is delivered to the process below. Since all ingredients are being metered at the same time, there is no layering of ingredients, and the overall batch time as well as further processing times downstream are greatly reduced.

This method of batching is preferred where micro ingredients are involved, since highly accurate weighing is often required by the recipe and by the desire to control the cost of expensive ingredients.

**Gain-in-Weight (GIW) versus Loss-in-Weight (LIW)**

Batch size, number of materials, material characteristics and accuracy requirements will all influence which type of batching — via loss-in-weight or gain-in-weight feeding — is best. Typical accuracies that can be expected with the GIW method of batch weighing are +/- 0.5% of the full scale capacity. LIW batching delivers +/- 0.1 - 0.5% of batch weight setpoint (see table).

**Comparison Chart: Loss-in-Weight vs. Gain-in-Weight Batching**

Requirements	Loss-in-Weight Batching	Gain-in-Weight Batching
Accuracy	0.1 - 0.5 % of batch weight setpoint	0.5 % or greater of the overall capacity of the scale or load cells
Single ingredient batching	Best	Good - Depending on the size of the batch versus the overall scale capacity; highly dependent on container size versus ingredient weight %
Multi ingredient batching	Best - Quickest way to batch out multi ingredients simultaneously	Good - Only one component at a time
Cost	Moderate - Each feeder on load cells/scale	Lower - Volumetric feeders with one set of load cells/scale for receiving vessel
Containment designs for hazardous materials	Available	Available

The Gain-in-Weight batching method is necessarily sequential for each ingredient, and therefore requires a longer overall batching time than with LIW batching. This sequential feeding also results in a layering of ingredients, so that mixing may be required before dispensing the batch into the process.

In cases where multiple products (major, minor and/or micro ingredients) are batched into larger IBC containers, a combination of volumetric and loss-in-weight (LIW) feeders may be used. The volumetric feeders are used to batch out the major ingredients first, directly into the IBC on a platform scale. The LIW feeders are each mounted on individual weighing systems (load cells or scales), and are then used to simultaneously batch out the smaller percentage minor/micro ingredients.

The scale on which the vessel is located is then used to verify the overall total batch weight of all the components. This combination of LIW and GIW technologies eliminates the requirement to batch each ingredient separately, thus decreasing the overall process batch times.

Most floor scales do not have sufficient speed and resolution to detect small amounts of batched products relative to the larger overall weights of the IBC or process vessel. If accuracy requirements on minors are in the range of 0.1 to 0.5 %, LIW feeders are typically used with the feeders mounted on high speed digital load cells with 1 part in 4 million resolution. A LIW batch controller monitors material weight loss from the feeder hopper and controls the start/stop function of the feeder to control the achievement of batch weight setpoint.

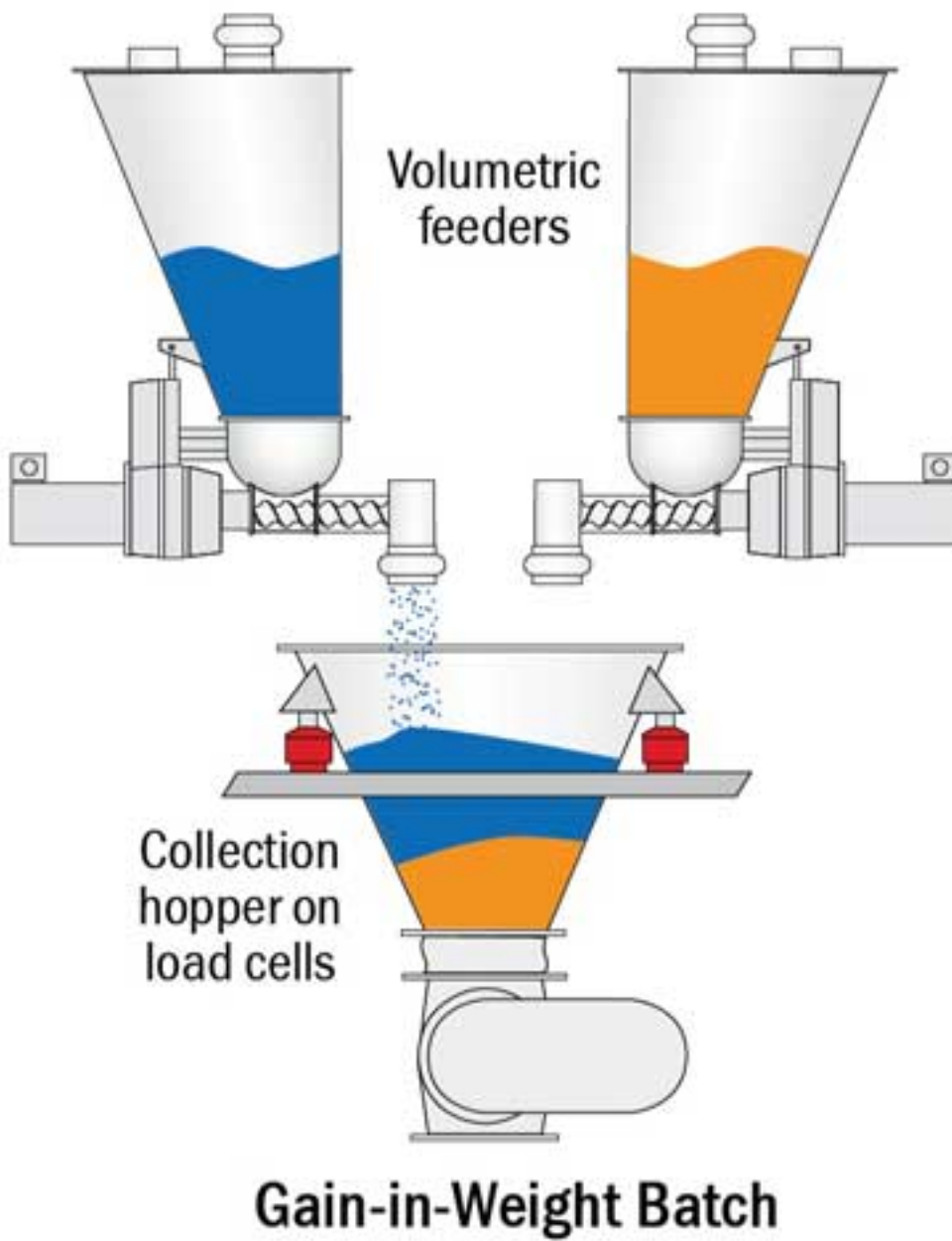



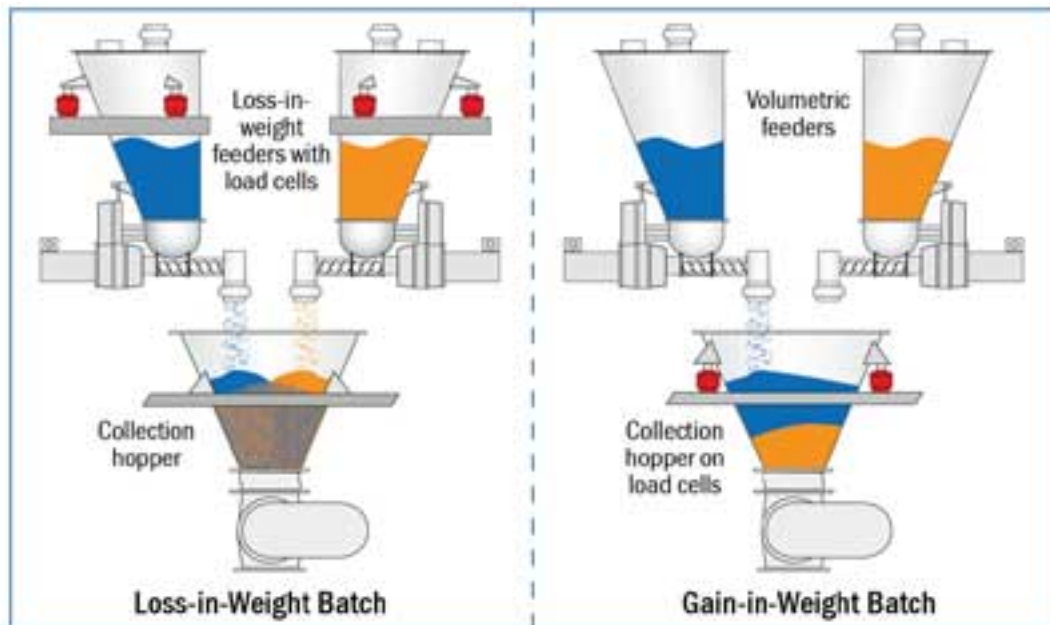

**Web Site Reference:**

<http://www.hardysolutions.com/solutions/solutions-by-application/batching-and-blending-make/batching-by-weight>

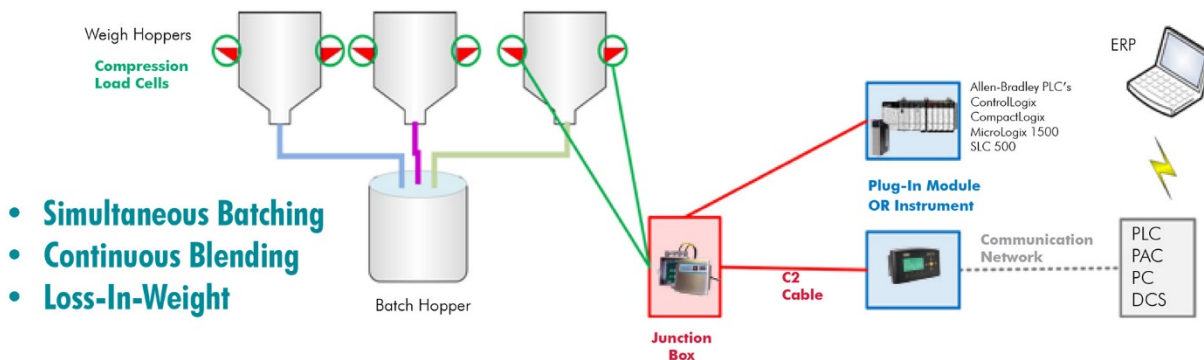

**Web Site Reference:**

[http://www.prochem.co.in/batching\\_systems.html](http://www.prochem.co.in/batching_systems.html)

Many powder handling systems require bulk weighing of large amounts of materials and the preparation of product batches for ingredient formulations. Typical applications are for food mixes, soups and flavourings, pre-mixed baking recipes, infant formulas, drinks, sauces, health and nutritional supplements, breakfast cereals, confectionery, pharmaceuticals and many others.

**Typical Features:**

- High accuracy load-cells and weight control electronics
- Gain-in-weight, loss-in-weight and continuous weighing systems
- Fast/bulk fill and slow/trickle filling with self-tuning pre-act systems

- Major, minor and micro ingredient dosing systems
- Maximized flexibility for variable recipes
- Automatic top-up systems
- Safe, sanitary and dust free systems
- Multiple ingredient systems
- State of the art control systems and recipe management using SCADA/HMI software for process visualization, inventory control, and reporting functions for management information systems.

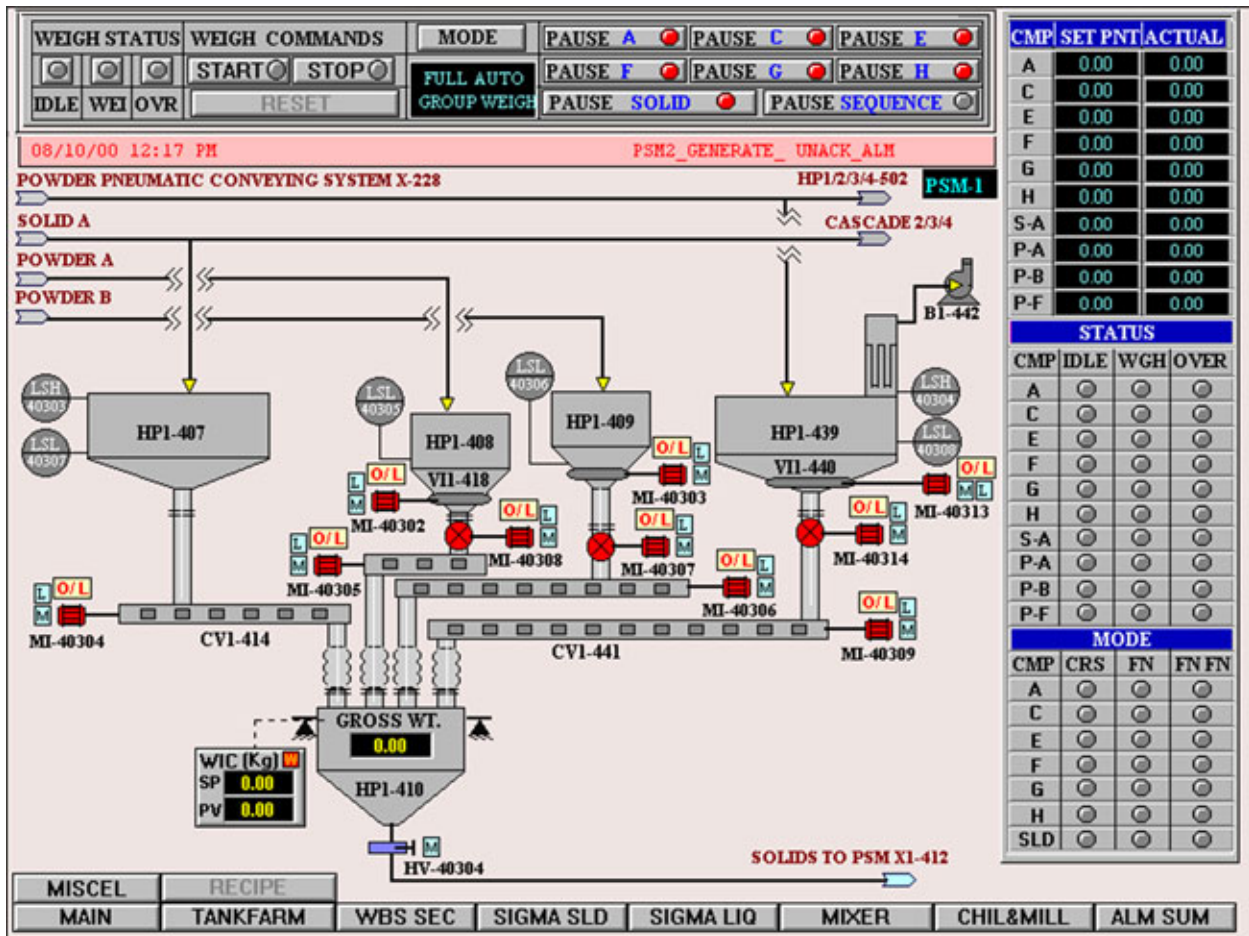

This publication is available free of charge from: <https://doi.org/10.6028/NIST.SP.1210>

## **8. 2014 NCWM Interim Meeting Report**

There was one item on the NCWM S&T Committee agenda for the 2013 NCWM Interim Meeting related to work done by the NTEP Software Sector. 2013 Publication 15, S&T Item 360-2 relates to the 2013 NTEP Software Sector Agenda Item 1: Marking Requirements.

From Jim Truex – the S&T Committee reported that it is considering withdrawing the item from their agenda if the Software Sector doesn't show some progress this year. By the end of August 28, 2014, this didn't seem like a likely result as we'd made significant progress on the item.

## **9. 2013 International Report**

Dr. Ambler Thompson, NIST, Office of Weights and Measures (OWM), will provide a synopsis of international activity that relates to the work of the Sector. Software Sector Co-Chair, Mr. Jim Pettinato will summarize the discussions that took place at the European Cooperation in Legal Metrology (WELMEC) WG7 meeting in December 2013.











Highlights of interest to the NTEP Software Sector:

- New WELMEC 7.2 draft document circulated for comment by WG7; and
- R-117 working group.

THIS PAGE INTENTIONALLY LEFT BLANK

## Sub-Appendix A

### Acceptable Menu Text/Icons for Weights Measures information

<i>Permitted Menu Text examples</i>	<i>Permitted Icon shape examples</i>	<i>Essential characteristics</i>
Information  Info	  	Top level menu text or icon: <ul style="list-style-type: none"> <li>• Icon text is a lower case “i” with block serifs.</li> <li>• Text color may be light or dark but must contrast with the background color.</li> <li>• Icon may have a circular border.</li> <li>• Activation of this menu text/icon may invoke a second level menu text/icon that recalls metrology information.</li> </ul>
Help  ?	 	Top level menu text or icon: <ul style="list-style-type: none"> <li>• Icon text is a question mark.</li> <li>• Text color may be light or dark but must contrast with the background color.</li> <li>• Icon may have a circular border.</li> <li>• Activation of this menu text/icon may invoke a second level menu text/icon that recalls metrology information.</li> </ul>
Metrology  Metrological Information	 	Top or second level menu text or icon: <ul style="list-style-type: none"> <li>• Icon text is an upper case “M.”</li> <li>• Text color may be light or dark but must contrast with the background color.</li> <li>• Icon may have a circular, rectangular, or rounded rectangle border.</li> <li>• If present, the activation of this menu text/icon must recall at a minimum the NTEP CC number.</li> </ul>
NTEP Data  N.T.E.P. Certificate		This one is debatable – what if the certificate is revoked? Does NTEP grant holders of CCs the right to display the logo on the device, or just in documentation?
Weights & Measures Info	 	

This publication is available free of charge from: <https://doi.org/10.6028/NIST.SP.1210>

THIS PAGE INTENTIONALLY LEFT BLANK

## Sub-Appendix B Software Sector 2014 Goals Presentation

### SOFTWARE SECTOR 2014

#### Software Identification Goals (1/2)

- Each piece of physical equipment is unique and needs a serial number
- Software by itself is non-unique; it does **not** need a serial number
- All metrologically significant software, embedded or PC-based, needs version/revision identification
- Identification is best provided by the software itself; there is no guarantee that a hard-marked version/revision matches what is running

NTEP SOFTWARE SECTOR ACTIVITY 2013

#### Software Identification Goals (2/2)

- Metrologically significant software and its version/revision identification must be linked together; it must not be possible to modify the software without a change to its identification and vice versa.
- Changes to metrologically significant software made after placement in service must be evident

NTEP SOFTWARE SECTOR ACTIVITY 2013

## Effecting Desired Changes

- Handbook 44: Current marking requirements for software in GS-1 are different for built-for-purpose and not-built-for-purpose
- HB44 has wide reaching impact and changes are understandably scrutinized by all, difficult to modify
- New goal is to implement the consensus items with minimal impact on existing HB 44 language
- Propose to add explanations and clarifications of intent to Publication 14

NTEP SOFTWARE SECTOR ACTIVITY 2013

## Software Identification

- Software must be identified, preferably self
- Handbook 44 proposed change:
  - Software identification must be displayable or printable, unless impossible (applies to all metrologically significant software)
- Publication 14 proposed additions:
  - Define software separation and explain options to submit software either as a monolithic entity that includes metrologically significant software or as a separated piece of metrologically significant software
  - Explain that metrologically significant software and its version/revision identifier must be linked together

NTEP SOFTWARE SECTOR ACTIVITY 2013



## Recommended Additions to Publication 14

### **“Identification of Certified Software:**

*Note: Manufacturers may choose to separate metrologically significant software from non-metrologically significant software. Separation would allow the revision of the non-metrological portion without the need for further evaluation. In addition, non-metrologically significant software may be updated on devices without breaking a seal, if so designed. Separation of software requires that all software modules (programs, subroutines, objects etc.) that perform metrologically significant functions or that contain metrologically significant data domains form the metrologically significant software part of a measuring instrument (device or sub-assembly). If the separation of the software is not possible or needed, then the software is metrologically significant as a whole. The conformity requirement applies to all parts and parts shall be marked according to Section G-S-X.X.*

*The manufacturer must describe and possibly demonstrate how the version or revision identifier is directly and inseparably linked to the metrologically significant software. Where the version revision identifier is comprised of more than one part, the manufacturer shall describe which portion represents the metrologically significant software and which does not.”*

NTEP SOFTWARE SECTOR ACTIVITY 2013

## Software Protection

- Update of metrologically significant software must be protected
  - **Physical seal can protect software update but current event counters/audit trails may not**
  - **No clear requirement for counters/event log to either take note of, or survive a software update intact**
- Publication 14 proposed addition:
  - **Update of metrologically significant software becomes a sealable event**

NTEP SOFTWARE SECTOR ACTIVITY 2013

## Recommended Additions to Publication 14

*“The updating of metrologically significant software, including software that checks the authenticity and integrity of the updates, shall be considered a sealable event.”*

NTEP SOFTWARE SECTOR ACTIVITY 2013

### Software Update

- Metrologically significant software contains algorithms, methods and procedures that operate on data, which includes both sealable and non-sealable parameters.
- Today, type approval evaluation considers protecting the modification of sealable parameters but ignores protecting the software that manipulates those sealable parameters.

NTEP SOFTWARE SECTOR ACTIVITY 201

### Software Update (cont.)

- Equipment protected by a physical seal may prevent the update of software unless a seal is broken and provides evidence of software update.
- Event Counter & Event Logger sealing methods lack any requirement for such protection today.
- Software Sector believes that the field update of metrologically significant software is at least as important as the field change of a metrologically significant parameter – either can adversely impact a future measurement result.
- Metrologically significant software update should be a sealable event.

NTEP SOFTWARE SECTOR ACTIVITY 201

## Future Vision

- Make Software Sector more visible/transparent
  - **Educate & better explain Software Sector objectives**
- Improve communication with other Sectors
  - **Propose to overlap Software Sector meetings with other Sector meetings to better align Publication 14 changes and speed up the consensus process**
- Finalize definition of 'easily recognizable' menu selections/icons to display software identification
- Provide checklists for software evaluations
- Assist in software-specific field training curriculum

NTEP SOFTWARE SECTOR ACTIVITY 2013

## Sub-Appendix C

### Attendees

**Doug Bliss**

Mettler-Toledo, LLC  
1150 Dearborn Drive  
Worthington, OH 43085  
P. (614) 438-4307  
F. (614) 438-4355  
E. doug.bliss@mt.com

**Tom Buck**

Ohio Department of Agriculture  
8995 East Main Street  
Reynoldsburg, OH 43068  
P. (614) 728-6290 F. (614) 728-6424  
E. tom.buck@agri.ohio.gov

**Darrell Flocken**

National Conference on Weights and Measures  
1135 M Street, Suite 110  
Lincoln, NE 68508  
P. (614) 620-6134  
E. darrell.flocken@ncwm.net

**Andy Gell**

FOSS North America  
8091 Wallace Road  
Eden Prairie, MN 55344  
P. (952) 974-9892  
F. (800) 547-6275  
E. agell@fossna.com

**Teri Gulke**

Liquid Controls  
105 Albrecht Drive  
Lake Bluff, IL 60044-2242  
P. (847) 283-8346  
F. (847) 295-1170  
E. tgulke@idexcorp.com

**Tony Herrin**

Cardinal Scale Manufacturing Co.  
203 E. Daugherty  
Webb City, MO 64870  
P. (417) 673-4631  
E. therrin@cardet.com

**Paul A. Lewis, Sr.**

Rice Lake Weighing Systems, Inc.  
230 W. Coleman St.  
Rice Lake, WI 54868  
P. (715) 234-6967  
E. plewis@ricelake.com

**Edward McIntosh**

F-RAMS, Inc.  
P.O. Box 2964  
Georgetown, TX 78627  
P. (512) 868-8101  
E. f-rams@mindspring.com

**Eric Morabito**

New York State W&M  
10 B Airline Drive  
Albany, NY 12206  
P. (518) 457-3452  
E. eric.morabito@agriculture.ny.gov

**Christopher (Adam) Oldham**

Gilbarco, Inc.  
7300 West Friendly Avenue  
High Point, NC 27420  
P. (336) 547-5952  
E. adam.oldham@gilbarco.com

**Edward Payne**

Maryland Department of Agriculture  
50 Harry S. Truman Parkway  
Annapolis, MD 21401  
P. (410) 841-5790  
E. edward.payne@maryland.gov

**James M. Pettinato, Jr.**

Senior Software Engineer  
FMC Technologies, Inc.  
1602 Wagner Ave.  
P. (814) 898-5000  
E. jim.pettinato@fmcti.com

**Ambler Thompson**

NIST, Office of Weights and Measures  
100 Bureau Drive, MS 20600  
Gaithersburg, MD 21701  
P. (301) 975-2333  
E. [ambler@nist.gov](mailto:ambler@nist.gov)

**Zacharias Tripoulas**

Maryland Department of Agriculture  
50 Harry S. Truman Parkway  
Annapolis, MD 21401  
P. (410) 841-5790  
F. (410) 841-2765  
E. [zacharias.tripoulas@maryland.gov](mailto:zacharias.tripoulas@maryland.gov)

**Jim Truex**

National Conference on Weights and Measures  
1135 M Street, Suite 110  
Lincoln, NE 68508  
P. (740) 919-4350  
F. (740) 919-4348  
E. [jim.truex@ncwm.net](mailto:jim.truex@ncwm.net)

**Mike Wedman**

California Division of Measurement Standards  
6790 Florin Perkins Road, Suite 100  
Sacramento, CA 95828  
P. (916) 229-3014 F. (916)229-3026  
E. [mike.wedman@cdfa.ca.gov](mailto:mike.wedman@cdfa.ca.gov)

**Kraig Wooddell**

Hobart Corporation  
701 Ridge Avenue  
Troy, OH 485374  
P. (937) 332-2238  
E. [kraig.wooddell@hobartcorp.com](mailto:kraig.wooddell@hobartcorp.com)

*Note: The first day of the Software Sector meeting was held in conjunction with the NTEP Weighing Sector whose attendees were also present.*

To determine the error on a typical delivery, the service agent needs to calculate the error introduced by the startup and shutdown gallons, and then the error introduced at the higher flow rates.

For a 500 gallon delivery in this example, the meter would register 10 gallons on startup but actually deliver 10.04 gallons. It would then jump to normal rate and deliver 79.92 gallons for every 80 gallons it registers until it goes into shutdown mode when it slows down and again delivers 10.04 gallons as it registers only an additional 10 gallons.

**SLOW FLOW RATE IS +0.4 g/100 G, AND CALIBRATION OF NORMAL RATE WAS ADJUSTED TO COMPENSATE**

Customer ordered 500 gallons of product.

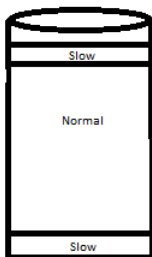
Meter registers:		Meter dispenses:
10 gallons		10.04 gallons
480 gallons		6 X 79.92 = 479.52 gallons
10 gallons		10.04 gallons

Meter registers 500 gallons but only delivers 499.6 gallons.

The error would be well within maintenance tolerance so the Weights and Measures official need only be concerned if the slow flow errors on all the meters for a particular product are in the same direction. At that point, the official should determine the direction of the error on a typical delivery to determine if the equipment is being properly maintained. Device users can ensure they have no problems with this requirement by making sure that slow flow errors are not predominantly in one direction.

## Appendix F

### Item 337-1:

#### **Submitters Background and Justification for Handbook 44 Definition of “Diesel Gallon Equivalent (DGE)” of Compressed Natural Gas (CNG) and “Liquefied Natural Gas (LNG)” as a Vehicular Fuel**

##### **Clean Vehicle Education Foundation**

##### *Development of the “Gasoline Gallon Equivalent” by NCWM\**

In 1993, under the auspices of the National Conference on Weights and Measures (NCWM), a Compressed Natural Gas (CNG) Working Group came together to determine the way in which CNG would be sold to the public at retail as a motor fuel.

The working group focused on three issues:

1. How to provide the Natural Gas Vehicle (NGV) industry a method of sale that would be familiar and acceptable to consumers
2. How to provide weights and measures officials a verifiable and quantifiable means to determine the accuracy of natural gas dispensers; and
3. How to meet these requirements with a uniform, national standard.

NCWM considered three proposals for the method of sale of CNG:

1. Joules, the unit of energy measurement in SI units
2. Mass
3. The Gasoline Gallon Equivalent (GGE)

The Natural Gas Vehicle Coalition (now NGV America) recommended that the Gasoline Gallon Equivalent be adopted as the method of sale for CNG, and that it be based on the energy equivalent of a gallon of gasoline. The use of the GGE was recommended primarily for the convenience of the retail customer comparing the cost and fuel economy of a natural gas vehicle to a comparable gasoline vehicle. During the discussion, a proposal was made to eliminate the reference to energy content of CNG and replace it with a fixed conversion factor based on mass, with the fixed mass of CNG being equal to a gallon of gasoline. Measurement of mass in the retail dispenser and verification by W&M officials is easier and less costly than measurement of energy content.

Since the energy content of a unit measure of CNG (standard cubic foot - scf) and gasoline (gallon) vary widely depending on the sample of fuel measured, the reference gallon of gasoline was determined to be Indolene, the gasoline used by EPA to certify emissions and fuel economy, with an energy content (lower heating value) of 114,118 BTU/gal. Work conducted by the Institute of Gas Technology and the Gas Research Institute (now combined into the Gas Technology Institute) surveyed 6811 samples of natural gas nationwide and concluded that the “average” natural gas in the U.S. had an

\* *Report of the 78<sup>th</sup> National Conference on Weights and Measures, 1993*, NIST Special Publication 854, pp 322-326.

*Report of the 79<sup>th</sup> National Conference on Weights and Measures, 1994*, NIST Special Publication 870, pp 213-217.

*Program and Committee Reports for the National Conference on Weights and Measures, 79<sup>th</sup> Annual Meeting, July 17-21, 1994*, NCWM Publication 16, pp 89-92.



energy content (lower heating value) of 923.7 BTU/scf, and a density of 0.0458172 lbs/cubic foot. This translates 20,160.551 BTU/lb. Dividing gasoline's 114.118 BTU/gal by natural gas's 20,160.551 BTU/lb gives 5.660 lbs of natural gas = 1 GGE. Similar calculations determined that a gasoline liter equivalent of natural gas equals 0.678 kg of natural gas.

At its 79<sup>th</sup> Annual Meeting in July of 1994, NCWM adopted resolutions that: “All natural gas kept, offered or exposed for sale or sold at retail as a vehicle fuel shall be in terms of the gasoline liter equivalent (GLE) or gasoline gallon equivalent (GGE), and

All retail natural gas dispensers shall be labeled with the conversion factor in terms of kilograms or pounds. The label shall be permanently and conspicuously displayed on the face of the dispenser and shall have either the statement “1 Gasoline Liter Equivalent (GLE) is equal to 0.678 kg of Natural Gas” or “1 Gasoline Gallon Equivalent (GGE) is equal to 5.660 lbs of Natural Gas” according to the method of sale used.”

These statements can be found in NIST Handbook 130<sup>\*</sup>, along with the definition of “natural gas” which seems to apply only to Compressed Natural Gas, not to Liquefied Natural Gas. Handbook 130, §§3.11 and 3.12 (Engine Fuels, Petroleum Products, and Automotive Lubricants Regulations) confirm that these requirements are for CNG, rather than LNG. Similar requirements and definitions are found in Handbook 44.

During the discussions it was recognized that, although diesel and gasoline are both sold in gallon units, a gallon of diesel fuel has substantially more energy content than a gallon of gasoline. While it is convenient to use the Gasoline Gallon Equivalent unit when comparing the cost and fuel economy of gasoline-powered light-duty vehicles to equivalent natural gas vehicles, a Diesel Gallon Equivalent unit would be more useful for operators of medium and heavy-duty (usually diesel powered) vehicles. However, in 1994, the NCWM working group “agreed to defer development of a “Diesel Gallon Equivalent” until the issues related to the ‘Gasoline Gallon Equivalent’ were decided by the NCWM and agreed to meet again if additional work is necessary.”\*\* The issue of the formal definition a Diesel Gallon Equivalent (DGE) unit has not come before NCWM from that time until today, although the DGE is often used in the industry, defined as 6.31 lbs of compressed natural gas.

*Need for a Definition of a “Diesel Gallon Equivalent” Unit*

Today there are an increasing number of commercial vehicles using natural gas as a fuel, to lower emissions and Greenhouse Gases, decrease America's use of petroleum, and lower fuel costs (U.S. DOE Clean Cities Alternative Fuel Price Report for April 2012

\* “Method of Sale Regulation,” §2.27

\*\* *Report of the 79<sup>th</sup> National Conference on Weights and Measures, 1994*, NIST Special Publication 870, p 214

shows in Table 2 ‘Overall Average Fuel Price on Energy-Equivalent Basis’ that diesel is priced at \$4.12/gal and CNG at \$2.32/gal [http://www.afdc.energy.gov/afdc/pdfs/afpr\\_apr\\_12.pdf](http://www.afdc.energy.gov/afdc/pdfs/afpr_apr_12.pdf)).

Since the NCWM’s working group deferred development of a DGE unit in 1994, there has been little call by the natural gas vehicle industry for the formalization of that unit in the sale of Compressed Natural Gas. However, the use of **Liquefied** Natural Gas (LNG) as a motor fuel has been growing (more than 350 LNG stations are being built on the nations interstate Highways) and there is significant interest in using the DGE as a unit for the sale of that fuel.

LNG as a motor fuel is used almost exclusively by commercial vehicles, most of which view diesel as the conventional alternative. Using the same logic as was used for the development of the GGE unit, the convenience of the retail customer comparing the cost and fuel economy of a natural gas vehicle to a comparable conventional vehicle, it makes sense for NCWM to now “officially” define the DGE.

Other than §3.12. Liquefied Natural Gas, in the Engine Fuels and Automotive Lubricants

Regulation section of Handbook 130, we find no specific provisions in either Handbook 44

or Handbook 130 for the retail sale of LNG as a motor fuel. However LNG is sold in

California and other states on a mass basis (by the pound), which allows for easy confirmation by weights and measures authorities. An “official” definition of the DGE as a specific mass of LNG and CNG would allow states to easily move from retail sale by pound to retail sale by DGE, simplifying the sale process for the retail customer used to dealing with “gallons of diesel” as a fuel measure.

Therefore, at this time we are asking for a definition of the Diesel Gallon Equivalent (and Diesel Liter Equivalent) units by NCWM.

*Justification of the Definition of a DGE as 6.38 Pounds of Compressed Natural Gas* Handbook 130

contains the following definitions of natural Gas as a vehicle fuel<sup>\*</sup> : **Gasoline liter equivalent (GLE).** –

Gasoline liter equivalent (GLE) means  
0.678 kg of natural gas.

**Gasoline gallon equivalent (GGE).** – Gasoline gallon equivalent (GGE) means  
2.567 kg (5.660 lb) of natural gas.

As the NCWM working group recognized during its deliberations in 1993 on the Gasoline Gallon Equivalent unit, both gasoline and natural gas can vary in their BTU content from sample to sample. The working group determined the gasoline gallon (energy) equivalent based on a gallon of Indolene (114,118 BTU/gal – lower heating value) and a survey of 6811 natural gas samples nationwide with an average of 923.7

BTU/scf (lower heating value) and a density of 0.0458172 lbs/cubic foot. This equates

---

\* NIST handbook 130, 2006, Method of State Regulation, §§2.27.1.2 and 2.227.1.3; also Engine Fuels, Petroleum Products, and Automotive Lubricants Regulation, §§1.25 and 1.26.

to 20,160.551 BTU/lb. Dividing gasoline's 114.118 BTU/gal by natural gas's 20,160.551 BTU/lb gives 5.660 lbs of natural gas = 1 GGE. Similar calculations determined that a gasoline liter equivalent of natural gas equals 0.678 kg of natural gas.

Starting with 5.660 lbs of natural gas = 1 GGE and 0.678 kg of natural gas = 1 GLE, we can calculate the mass of natural gas necessary to make a DGE and a DLE by comparing the amount of energy in a gallon of diesel fuel to the amount of energy in a gallon of gasoline fuel and apply that ratio to scale up the masses of natural gas calculated for the GGE and GLE units.

Unfortunately, it is no easier today than it was in 1993 to set one energy value as representative of a unit for all gasoline, (or diesel) fuel. EPA's certification fuel has likely changed in energy content since 1993, as both gasoline and diesel fuels have been modified for improved emissions.

We recommend using the most recent Department of Energy *Transportation Energy Data Book*<sup>\*</sup>, as an authoritative reference for both gasoline and diesel fuel energy values. Taking further surveys or basing our calculations on today's EPA certification fuel only delays our action, substantially increases costs, and, in the end, provides a limited potential increase in accuracy based on one point in time. Table B.4 of the *Transportation Energy Data Book*, on the heat content of fuels lists the net energy of diesel as 128,700 BTU/Gal. The 31<sup>st</sup> Edition may be downloaded at the following site.

<http://cta.ornl.gov/data/download31.shtml>

Therefore a Diesel Gallon Equivalent of compressed natural gas is:  $(128,700 \text{ BTU/Gal} / 20,160.551 \text{ BTU/lb}) = 6.38 \text{ lb/DGE}$  (2.894 kg/DGE) and a Diesel Liter Equivalent of compressed natural gas is:

$2.894 \text{ kg/DGE} \times 0.2642 \text{ Gal/Liter} = 0.765 \text{ kg/DLE}$

#### *Justification of the Definition of a DGE as 6.06 Pounds of Liquefied Natural Gas*

Cooling pipeline natural gas to  $-259^{\circ}\text{F}$  makes liquefied Natural Gas (LNG). The pipeline natural gas has the same national average composition as was determined for CNG

with a LHV of 20,160.551 BTU/lb. In order to reduce the natural gas temperature for liquefaction carbon dioxide must be removed since it would solidify in the system and

nitrogen, which remains a gas at LNG temperatures, is reduced to less than 0.5% by volume in the final product. These changes to the composition of the pipeline gas increase the LHV of LNG to 21,240 BTU/lb.

---

\* Stacy C. Davis and Susan W. Diegel, Oak Ridge National Laboratory, *Transportation Energy Data Book*, Edition 31, 2012, ORNL-6987, or <http://cta.ornl.gov/data/index.shtml>

National Average Natural Gas Composition Used for GGE Standard - Applied to LNG DGE - GGE Calculation							
CNG				LNG			
Components	LHV - BTU/LB	LBS/CF	%V <sup>1</sup>	%V <sup>2</sup>	LBS/CF	%MASS	LHV
C1	21537	0.0425	92.87	95.12	0.040425567	90.29305699	19446.41568
C2	20394	0.0803	3.34	3.42	0.002746969	6.13552872	1251.279727
C3	19807	0.1196	0.63	0.65	0.000771727	1.723700114	341.4132816
i-C4	19529	0.1582	0.07	0.07	0.000113422	0.253334595	49.47371306
n-C4	19815	0.1582	0.12	0.12	0.000194437	0.434287877	86.05414286
i-C5	19478	0.1907	0.04	0.04	7.81272E-05	0.174502103	33.98951966
n-C5	20485	0.1907	0.03	0.03	5.85954E-05	0.130876577	26.81006688
C6	19403	0.0228	0.05	0.05	1.16761E-05	0.026079234	5.06015379
N2	0	0.0744	2.07	0.50	0.000370992	0.828633789	0
CO2	0	0.117	0.78	0.00	0	0	0
			100.00	100.00	0.044771512	100	21240
						Diesel <sup>3</sup> LHV=	128,700
						LNG - DGE=	6.06

<sup>1</sup> CNG national average composition of natural gas from the NCWM Laws and Regulations - CNG Working Group letter 10/18/1993 Appendix A. Conversion Factor Background

<sup>2</sup> LNG composition based on CNG composition with CO2 removed and nitrogen reduced to 0.5%

<sup>3</sup> DOE Transportation Energy Data Book Table B.4

Note: each 0.1% reduction/addition of nitrogen in LNG lowers/raises DGE by 0.01 lb

Therefore a Diesel Gallon Equivalent of LNG is:

$$128,700 \text{ BTU/lb} / 21,240 \text{ BTU/lb} = 6.06 \text{ lb/DGE} (2.749 \text{ kg/DGE})$$

and a Diesel Liter Equivalent of LNG is:

$$2.749 \text{ kg/DGE} \times 0.2642 \text{ Gal/Liter} = 0.7263 \text{ kg/DLE}$$

The attached presentation file provides an overview of the CNG and LNG processes from pipeline to dispensing along with the calculation of the LNG LHV based on the change in LNG chemical composition through the liquefaction process.

Prepared by:

Clean Vehicle Education Foundation

<http://www.cleanvehicle.org>

# Clean Vehicle Education Foundation



## Proposal for CNG & LNG – DGE

### NCWM

### March 20, 2013

Douglas Horne – President

12/10/13 [www.cleanvehicle.org](http://www.cleanvehicle.org) 1

## Why DGE is Now Needed by the NGV Market

- In the 1994 NCWM set GGE at 5.66 lbs but deferred the development of DGE because:
  - The consumer market was LD gasoline conversions 
  - and diesel class NGVs were fleets such as transit that use private stations.  

In the last twenty years the market growth has been in HD vehicles and now a national network of of public CNG and LNG - LCNG fueling is emerging



CNG Class 8

LNG Class 8

CNG HD

12/10/13 [www.cleanvehicle.org](http://www.cleanvehicle.org) 2



This publication is available free of charge from: <https://doi.org/10.6028/NIST.SP.1210>



## CNG DGE

### Based on 1994 NCWM GGE Standard

- The 1994 acceptance NCWM of Gasoline Gallon Equivalent (GGE) for natural gas to be equal to 5.660 lbs was based on a national weighted average composition of natural gas
  - density of 0.0458172 lbs/scf
  - LHV = 20,160.551 BTU/lb
- Using the the same natural gas composition and the LHV of diesel noted in Table B.4 of the DOE Transportation Energy Data Book
  - 128,700/20,160.551 gives the Diesel Gallon Equivalent (DGE) of 6.38 lbs
- For those NGVs that use CNG as a replacement for diesel, a DGE of CNG would be 6.38 lbs

12/10/13 [www.cleanvehicle.org](http://www.cleanvehicle.org) 4

This publication is available free of charge from: <https://doi.org/10.6028/NIST.SP.1210>

## DGE for Vehicle Using LNG and

- As shown in the LNG delivery system slide the national average pipeline gas has a LHV of 20,160 BTU/lb and during liquefaction the inert gas constituents are reduced thus increasing the LHV to 21,240 BTU/lb
  - For those NGVs that use LNG as a replacement for diesel, a DGE of LNG would be 128,700 LHV diesel divided by 21,240 LHV of LNG equaling 6.06 lbs

12/10/13

[www.cleanvehicle.org](http://www.cleanvehicle.org)

5

## DGE & GGE Based on LNG Composition

National Average Natural Gas Composition Used for GGE Standard - Applied to LNG DGE - GGE Calculation								
Components	CNG			LNG				
	LHV - BTU/LB	LBS/CF	%V <sup>1</sup>	%V <sup>2</sup>	LBS/CF	%MASS	LHV	
C1	21537	0.0425	92.87	95.12	0.040425567	90.29305699	19446.41568	
C2	20394	0.0803	3.34	3.42	0.002746969	6.13552872	1251.279727	
C3	19807	0.1196	0.63	0.65	0.000771727	1.723700114	341.4132816	
i-C4	19529	0.1582	0.07	0.07	0.000113422	0.253334595	49.47371306	
n-C4	19815	0.1582	0.12	0.12	0.000194437	0.434287877	86.05414286	
i-C5	19478	0.1907	0.04	0.04	7.81272E-05	0.174502103	33.98951966	
n-C5	20485	0.1907	0.03	0.03	5.85954E-05	0.130876577	26.81006688	
C6	19403	0.0228	0.05	0.05	1.16761E-05	0.026079234	5.06015379	
N2	0	0.0744	2.07	0.50	0.000370992	0.828633789	0	
CO2	0	0.117	0.78	0.00	0	0	0	
			100.00	100.00	0.044771512	100	21240	
							Diesel <sup>3</sup> LHV=	128,700
							LNG - DGE=	6.06

<sup>1</sup>CNG national average composition of natural gas from the NCWM Laws and Regulations - CNG Working Group letter 10/18/1993 Appendix A. Conversion Factor Background

<sup>2</sup>LNG composition based on CNG composition with CO2 removed and nitrogen reduced to 0.5%

<sup>3</sup>DOE Transportation Energy Data Book Table B.4

Note: each 0.1% reduction/addition of nitrogen in LNG lowers/raises DGE by 0.01 lb

12/10/13

[www.cleanvehicle.org](http://www.cleanvehicle.org)

6

## Proposal

- CNG dispensers may dispense natural gas in two units:
  - GGE = 5.66 lbs
  - DGE = 6.38 lbs
- LNG dispensers will dispense LNG in one unit:
  - DGE = 6.06 lbs

12/10/13

[www.cleanvehicle.org](http://www.cleanvehicle.org)

7

## CVEF Contact Information

- Douglas Horne – President  
[dbhorne@cleanvehicle.org](mailto:dbhorne@cleanvehicle.org)  
770-424-8575
- [www.cleanvehicle.org](http://www.cleanvehicle.org)



12/10/13

[www.cleanvehicle.org](http://www.cleanvehicle.org)

8



THIS PAGE LEFT INTENTIONALLY BLANK

## Appendix G

### Agenda Item 337-1:

#### **OWM’s Technical Analysis of Agenda Item 337-1. The Following OWM Technical Comments and Recommendations Were Provided in Written Form to Members of the S&T Committee on July 15, 2015**

OWM believes it is essential to establish and follow a method of sale (MOS) for natural gas that provides uniformity, transparency, and accuracy, as has historically been the case with all other commodities offered for sale in the U.S. The community is preparing for increased sales in a fueling application (CNG) first recognized by weights and measures in the mid-1990s and a new alternative fuel application (LNG). Since the 1990s, CNG sales have been largely made in the arena of fleet operations that have invested in CNG-fueled vehicles. In these applications the very livelihood of the fleet customers rests on their being informed consumers who are intimately familiar with budgeting; making value comparisons based on mileage per unit of fuel cost; and bargaining on the price of fuel. New fueling operations opening to the general public will be represented by existing and new stations and offer service to general consumers and distance haulers. Regardless of the MOS, this new customer base will face learning curves as the drivers, the stations, and the officials become familiar with these fuels and their characteristics.

There has been much in-depth thought, consideration, and discussion of what is the most appropriate method of sale for compressed natural gas (CNG) and liquefied natural gas (LNG) vehicle fuel. Various proposals have been put forth before the NCWM for consideration of adoption into NIST Handbook 44 and NIST Handbook 130 to establish the MOS of these products. Whatever proposal is chosen, it must fully satisfy the basic principles of measurement and philosophies of weights and measures that include promoting and ensuring equity in the marketplace; traceable standards; uniformity; a basis for value comparison; transparency of the transaction; consumer protection; and fair business practices and competition.

OWM offers the following brief list of considerations based on its technical analysis of the issues surrounding this item. This brief list is followed by a more in-depth discussion of each point.

- ***Weights and Measures Principles.***  
A fundamental legal metrology principle is to ensure that equity prevails in any commercial weighing or measuring transaction. This includes ensuring that not only is a measurement based on a traceable unit of measure, but the practices surrounding the measurement and its application provide for clear and understandable transactions that facilitate value comparisons and promote fair competition. Equivalent “units” are not traceable units and their use and implementation may frustrate value comparison and affect the ability of businesses, including other types of fueling applications, to fairly compete.
- ***Sale by Mass with Supplemental Information.***  
OWM believes that the best option is to require the sale of all natural gas in mass units (kg or lb) as measured by the metering technology and as outlined in the “Mass Compromise Proposal.” This option ensures a technically correct solution, yet still provides the flexibility to provide consumers with comparison information on multiple other fuels and potentially create less confusion than permitting sales in multiple different “equivalent” values as “units” of measure. The inclusion of supplemental information is a longstanding, valid practice and can provide valuable information to assist consumers in making purchase decisions, but that information should not be used as the basis of measurement and sale.
- ***Limited Data to Support Equivalent “Units.”***  
There is limited current data to support the proposed equivalent “units” for the various fuels. Industry acknowledges that the reports/studies referenced as basis for the energy content used to arrive at the diesel equivalent values are not supported by scientific data gathered in the same manner as the natural gas data that was the basis for the GGE. In the 1990s, the weights and measures community acknowledged that fuel energy analysis was not practical and that is still the case today. However, metering technology currently

exists and has been type approved for commercial use that is capable of making traceable natural gas fuel measurements based on mass that provides an alternative to the proposed, inexact methodology. Note also that there are errors (as previously noted by OWM) in the report that should be corrected in the final report.

- ***Fixed Conversion Values Not Representative of Fuel.***  
Establishing fixed “equivalent values” does not reflect the variation in natural gas or the energy content of the fuels the “equivalents” are based upon. Fixing these values for use as a measurement unit would limit information about natural gas supplies in a consumer’s area. Some states have reported companies using different conversion factors for existing CNG applications (i.e., factors other than the 5.660 lb value established in 1994 for 1 GGE), and struggling to get uniformity in the values programmed into dispensers. Over the last two decades, a large number of CNG applications have provided services to (relatively-informed) fleet operations rather than the general public.
- ***Frustrating Value Comparisons.***  
Devices that dispense natural gas as an engine fuel will serve a broad base of customers who may need to compare natural gas multiple different fuel types, including diesel, biodiesel, gasoline, fuel ethanol, electric, hydrogen, LNG, and others not yet considered. If used as the basis of measurement, the use of different equivalent “units” (e.g., GGE, DGE, and others) at competing stations could frustrate value comparison and limit the ability to make value comparisons with multiple different fuel types.
- ***Proliferation in “Equivalent Units “and Lack of Uniformity.***  
Permitting use of an approximate value as the legal unit of measurement for trade encourages the creation of additional equivalent units for fuels and other products. This will lead to a lack of uniformity; affect the ability of businesses to compete; and lead to consumer confusion and frustrate value comparison, potentially discouraging the use of alternative fuels. Unlike most of the world, the U.S. is creating a new industry practice through the usage of new terms based on marketing practices rather than using a formal, technically sound approach, potentially putting U.S. industry at a disadvantage internationally.
- ***Impact on Existing Equipment.***  
Existing NTEP Certificates of Conformance issued for metering systems dispensing LNG only address dispensers displaying in mass. The impact on the continued acceptance of this equipment including costs and the need for re-evaluation should be considered in discussing any proposed changes.
- ***Conflict with L&R Proposals.***  
The S&T proposals in this item were modified during the January 2015 Interim Meeting. However, corresponding modifications were not made in all of the L&R proposals on natural gas. Consequently, there are conflicts between the S&T and L&R proposals that could lead to confusion in the marketplace if both sets of proposals are adopted as currently presented.
- ***LNG Code Development – Additional Work.***  
Additional work is needed to modify NIST Handbook 44 to fully recognize LNG applications so that there is a uniform basis for inspection/test and type approval procedures. NIST is developing a plan to present to the community for the development of proposed requirements to address LNG measuring devices.
- ***Additional Action Needed if the Current Proposal is Adopted.***  
Some states were encouraged to enact legislation that included specific DGE values for both CNG (6.380 lb) and LNG (6.06 lb) in their laws and regulations and may already have installations in use where fuel deliveries are in equivalent “units.” These jurisdictions should revisit their policies and field sites to determine if the fuel equivalent values conflict with those included in the current proposals.

Additional details and information on these issues are included below.

#### ***Weights and Measures Principles.***

A fundamental legal metrology principle is to ensure that equity prevails in any commercial weighing or measuring transaction. The delivery of full weight or measure and the elimination of fraud and misrepresentation (intentional

and unintentional) have been issues in commercial transactions throughout history. The weights and measures official stands between the buyer and the seller to help ensure fair, accurate, and transparent transactions and must represent the best interests of both parties. Not only does the official verify the accuracy of a commercial measurement, but the official must consider the business practices surrounding the transaction to ensure that consumers fully understand their basis and that competing businesses have a level playing field. Businesses offering competing fuel types may be put at a disadvantage and have difficulty competing with sales based on a non-traceable measurement “unit.”

To ensure the accuracy of commercial measurement transactions, those transactions must be based on units of measurement traceable to the SI. CNG and LNG measurement and sales in known and traceable units of mass (e.g., kilogram or pound) is not only verifiable, but also provides for clear and transparent transactions for consumers and businesses; can be supported and provide for traceable measurements from a metrological standpoint; and provides a fair basis for businesses to compete.

The proposed equivalent “units” are not traceable units. Equivalent units should only be presented as supplemental information; their purpose, to provide consumers with additional information to help facilitate an informed purchasing decision. They must not be used as the basis for the measurement transaction. While not intended to mislead consumers, these equivalents may give the false impression that they accurately represent the energy content of the specific product being dispensed relative to another fuel, which is not the case. Consumers and businesses alike rely on the use of traceable units as the basis for transactions to ensure that value comparisons can be made (in this case among different fuel types as well as different businesses) and that businesses are competing based on the same standards. Marketing practices, such as the creation of equivalent units, should be used to only promote and inform consumers about features of a potential purchase.

***Sale by Mass with Supplemental Information.***

The use of *supplemental* information to assist consumers in making value comparisons in the process of making a purchase decision is a widely accepted practice within the weights and measures community. For example, laundry detergent is often advertised with information about the approximate number of loads that might be obtained from the product. The actual number of loads may vary based on factors such as the characteristics of the water used; how dirty the clothes are that are being washed; how fully the washing machine is loaded; the efficiency of the machine; and even the quality of the detergent. What does not vary is the *quantity* of the product that is received; the quantity is required to be provided in traceable units of measure such as kilograms or pounds (for dry detergent) and liters or gallons (for liquid detergent) and that can be verified by officials and service providers during routine testing. And it is this verifiable quantity information that consumers can depend on as being accurate representations of the amount of product received in a purchase and can, thus, be used to make an informed value comparison among competing products. This quantity information is also what helps to ensure manufacturers and businesses are provided with a level playing field and the ability to fairly compete since marketing, advertising, and the sales transaction itself must be based on the same standard, verifiable, measured quantities for all businesses.

There are many other examples of products where supplemental information is provided such as paint that is accompanied by information about the approximate number of square feet that might be covered; fertilizer with the approximate area of lawn; and even some food products with the approximate number of servings that a consumer might expect for use in a recipe. There are also examples in the transportation arena where supplemental information is provided outside of the measurement/sales transaction. For example, mileage estimates are provided to consumers making new vehicle purchases and this information can also be found on transportation websites to assist consumers in making not only vehicle purchase decisions, but ongoing comparisons of fuel types. As with the laundry detergent example and other examples, actual results may vary. A specific vehicle may actually travel less or more than the estimated miles per gallon based on the speed of the vehicle, the number of stops, the use of air conditioning, whether the windows are up or down, the pressure in the tires, and the driving habits of the operator.

The proposed equivalent “units” for natural gas provide supplemental information that can be useful to consumers, but like other supplemental information, they provide only an approximation and, if used as the basis for measurement, would limit information provided to consumers about comparison with other fuel types. Under the “Mass Compromise Proposal,” customers could still be provided with supplemental information through mechanisms such as pump toppers that provide information about approximate energy values that correspond to deliveries indicated in mass. As an alternative to pump toppers, this information could be included on labels or on websites such as those that already provide information about fuel economy. This also opens the opportunity for the development of “apps” that might

enable a consumer to use a smart phone to quickly calculate and compare a purchase (or potential purchase) with *multiple* fuel types. And, as with mileage estimates, this information could be posted on transportation websites and possibly even updated more easily as supplies change. Using mass as the basis for measurement and sale might also help reduce complaints from suppliers concerning the accuracy of equivalent values used to represent deliveries of their product rather than the metered mass value. It has been acknowledged that “The Mass Compromise Proposal” might be more comprehensive and palatable if it also included corresponding street price signage requirements in NIST HB 130.

***Limited Current Data to Support Proposed Equivalency Values.***

In the 1990s, the weights and measures community acknowledged that fuel energy analysis was not practical at the retail level. The scientific community at NIST has indicated that sales of fossil and alternative fuels by energy content is appropriate when the constituent values of a fuel offered for sale can actually be determined at the time of sale. The energy a buyer can glean from fuel right now must factor in the variables in fuel supplies (well location, seasonal blends, etc.), engine efficiency, and vehicle and road conditions. Industry acknowledges that the reports/studies referenced as basis for the energy content used to arrive at the diesel equivalent values are not supported by scientific data gathered in the same manner as the natural gas data that was the basis for the GGE. The proposal currently presented in the “Item Under Consideration” sets a new precedent for a MOS using an inexact method for making fuel comparisons by averaging a fuel’s energy content and then further averaging that information to arrive at numerical values used in the determination of a fuel’s final cost. However, metering technology currently exists and has been type approved for commercial use that is capable of making traceable natural gas fuel measurements based on mass that provides an alternative to this inexact methodology.

The fuel property data in the current proposals is drawn from a transportation study rather than the agreed-upon process used in 1994. Additionally, the write up on the process in the current and previous S&T and L&R Interim Report Appendices includes mistakes such as the statement “Dividing gasoline’s 114.118 BTU/gal by natural gas’s 20,160.551 BTU/lb gives 5.660 lb of natural gas = 1 GGE,” which, when calculated actually equals 0.005660 lb. This information becomes the historical record of the process followed by the NCWM and should be corrected regardless of the overall decisions made by the NCWM on this issue.

The validity of the data supporting the process by which the conversion factors were derived should be vetted; undergo peer review; and be widely distributed. OWM suggested that FALS, with its standards network and history of expertise in fuel quality issues and field and laboratory standards as well as methods of fuel analysis, might be the best candidate to take on the necessary tasks of validating the values and the process used to arrive at the conversion factors. In January 2015, FALS tasked a small group of NCWM members to review the fuel data to determine if the data supports the conversion values in the proposals or some other numerical values and to report the group’s findings. Since January 2015, that sub group has met multiple times and recently (within the last two weeks) provided recommendations and information to be considered. OWM is currently reviewing this information and expects to provide its observations to the Committee prior to the 2015 NCWM Annual Meeting.

***Fixed Conversion Factors Not Representative of Fuel.***

Those in support of the proposed DGE/DLE have stated that gas supplies have remained relatively unchanged since the establishment of the GGE. However, others in industry, such as one measuring device manufacturer, have referenced the high degree of variability of the product. OWM notes there are opposing industry claims from the Clean Vehicle Education Foundation (CVEF) indicating that the heating value of natural gas is basically unchanged in 21 years, whereas Emerson Process Management stated in the NCWM 2014 Online Position Forum on Item 337-6 that “the specific gravity of LNG can vary as much as 12%, and that the constituents in natural gas (LNG) vary significantly and can be manipulated, thus impacting the measurement of the product. Although those comments were submitted under a separate item, the product being discussed, i.e., natural gas, is the same. The variability in gasoline was acknowledged in the 1992-1994 study and was so much so that “indolene” a standardized test gasoline that is free of additives, was used to establish the average energy content values for a gallon of gasoline. Even the previously agreed upon data may need revisiting given today’s gasoline can contain as much as 10 % ethanol. This point also needs to be considered in examining the data used to develop the proposed equivalent “units.”

Just like gasoline and diesel (the fuels on which the “equivalent values” are based), the energy content of natural gas varies. CNG and LNG are very different products than gasoline and diesel. CNG and LNG do not have the same physical characteristics as gasoline or diesel and they are measured using a different metering technology. Although

vehicle fuel dispensers may look similar externally, a CNG or LNG dispenser has the capability to indicate the fuel delivery in mass units; in fact, this is a requirement for testing purposes.

Some have claimed that use of the GGE conversion factor value established in the 1990s is accepted without complaint. OWM has received periodic complaints and concerns over the years from fuel suppliers having no knowledge of the decisions made in the 1990s to adopt a conversion factor (5.660 lb CNG/gallon of gasoline) based on the fuel supply having a lower energy content. Some states have reported companies using different conversion factors for existing CNG applications (i.e., factors other than the 5.660 lb value established in 1994 for 1 GGE), and weights and measures officials struggle to get uniformity in the values programmed into dispensers in the field. Over the last two decades, a large number of CNG applications have not provided services to the general public (many provided service to fleet operations instead) and, therefore, may not have been routinely regulated by weights and measures. It should also be noted that the 1994 entry of what was then a fledgling industry into legal metrology applications was somewhat contentious because of the use of an approximate conversion factor used to calculate fuel delivery and sales in equivalent volume units. Furthermore, the factor was and remains based on comparison with the averaged energy content of a conventional fuel resulting in a method of sale other than the originally debated sale of fuel by mass units.

***Frustrating Value Comparisons.***

Devices that dispense natural gas as an engine fuel will serve a broad base of customers who may need to compare natural gas multiple different fuel types, including diesel, biodiesel, gasoline, fuel ethanol, electric, hydrogen, LNG, and others not yet considered. If used as the basis of measurement, the use of different equivalent “units” (e.g., GGE, DGE, and others) on different dispensers at competing stations could frustrate value comparison and limit the ability for consumers to make value comparisons with multiple different fuel types. The weights and measures community must carefully consider the most appropriate means to provide sufficient information to customers attempting to make a value comparison of natural gas with these different fuel types, whether at the same station or stations on adjacent street corners.

Since there are multiple different fuel types, it may be difficult to pick a single equivalent “units” that would provide adequate information to the majority of consumers and avoid confusing others. For example, a dispenser might serve vehicles that are conventionally powered by diesel or gasoline fuel. The consumer who switches from a diesel- fueled vehicle may need to make comparisons with diesel fuel. The consumer who switches from a gasoline- powered vehicle may need to make comparisons with gasoline. Those who run flex-fueled vehicles may want to make ongoing comparisons depending on the most current fuel formulation. A natural gas dispenser may also serve consumers who run a flex fueled vehicle that utilizes multiple fuel types. If an equivalent “unit” for one fuel type is used as the basis for the transaction, this may lead to confusion for consumers who have the need to compare with other fuel types. Likewise, a proliferation of equivalent units at the dispenser may not only lead to consumer confusion and frustrate value comparison, but may also have the unintended effect of discouraging the use of natural gas as an alternative fuel.

Consumers may have a variety of reasons for making a decision to purchase a vehicle(s) that runs on natural gas rather than conventional petroleum product or vice versa, but one common denominator is the cost of vehicle fuel as part of the operational expense of a vehicle or fleet. This figure can also be used to determine short- and long-term fuel costs and, at some point, be used to calculate fuel cost per mile (or kilometer). The ability to look at fuel costs in this manner is more accurately represented by what the meter measured. Consumers evaluating the driving distance or mileage consider the size of the fuel tank (which can be listed in any unit of measurement), the vehicle engine efficiency for a particular fuel type, highway driving conditions, vehicle load and a number of other factors to truly determine their individual driving range. The fuel efficiency is one determining factor under consideration prior to a purchase and when purchasing their next vehicle. For the first purchase of a vehicle type the buyer will already have done this “homework” before making such a large investment, even researching the convenience of fueling a vehicle. Once a consumer has purchased a dedicated fueled vehicle, the need to make value comparisons are expected to diminish sharply.

A point that has been raised by some in the community is whether or not “equivalent values” are as necessary as they might have been at one time to encourage consumer acceptance of natural gas as an alternative fuel. For example, the SWMA questioned whether, once a consumer has purchased a vehicle he or she has the need to make ongoing value comparisons or whether this information is more useful prior to purchasing a vehicle. Given the concerns about

consumer confusion with a potential proliferation of “equivalent” values at the dispenser, perhaps requiring mass units on the dispenser (with supplemental information about equivalents) is a more appropriate approach.

***Proliferation in “Equivalent Units “and Lack of Uniformity.***

OWM and others in the community are concerned that permitting use of an approximate value as the legal unit of measurement for trade encourages the creation of additional equivalent units for fuels and other products and will lead to a lack of uniformity and affect the ability of businesses to compete. For example, OWM has already received an inquiry about the possibility of an equivalent “unit” for LPG. A proliferation of different equivalent “units” in the marketplace may not only lead to consumer confusion and frustrate value comparison, but may also have the unintended effect of discouraging the use alternative fuels.

When the measurement transaction departs from traceable, verifiable units of measure, businesses will ultimately have difficulty fairly competing and consumers will become frustrated. For natural gas retail motor-fuel applications, the United States, unlike most of the world, is also creating a new industry practice through the usage of new terms based on *marketing* practices rather than using a formal, technically sound approach. The U.S. system continues to move away from standards applied to similar commercial applications in the international community, which could, in the long term be detrimental to U.S. industry.

***Impact on Existing Equipment.***

Currently, there are six LNG dispensers with NCWM NTEP Certificates of Conformance (CC). These CCs are issued to Bennett Pump Co., Cryostar, Chart Industries, and NorthStar, Inc., to dispensers that display in mass, were tested based on flowrates in pounds per minute, and in several cases depicted on the CC with indications in the pound unit of measurement. It isn’t clear whether or not any testing was conducted in conjunction with these CCs on the use of equivalent “units” and the impact on these CCs should be considered, including the need to retest and reissue these CCs.

***Conflict with the L&R Proposal***

The joint efforts of the S&T and L&R Committees and the subsequent work of the Natural Gas Steering Committee and Natural Gas Fuels Equivalent Values Work Group are to be commended. Having reviewed so many iterations of handbook language, the collaborative work of the two committees may have taken an unintended direction since the wording in each committee’s proposal differs and may not be aligned as originally intended.

The most current versions of the S&T and L&R proposals conflict with one another. The S&T proposal references permissible indications of CNG dispensed as an engine fuel in terms of the gasoline gallon equivalent (GGE) or diesel gallon equivalent (DGE) or in mass units. It does not include references to a diesel liter equivalent (DLE) or gasoline liter equivalent (GLE). The L&R proposal, in addition to GGE, DGE, or mass units, also recognizes indications in GLE and DLE. If the two proposals were to be adopted as written, this could create confusion regarding the appropriate action to take if a retail motor-fuel dispenser (RMFD) is set up to dispense CNG in gasoline liter or diesel liter equivalents.

While OWM recognizes that industry requested references to DLE and GLE be removed from the S&T proposal based on current trade practices, it is not clear if the S&T proposal as written was intended to restrict the sale of CNG in mass units to the pound, or, if kilogram units would still be permitted given that the changes proposed to paragraph S.5.2. require the gallon volume equivalent (for diesel or gasoline, whichever the case) to be marked on the dispenser. OWM notes that metric units are still legally permissible in the U.S. However, recognizes, as specified in the “Foreword” to NIST Handbook 44, that in some cases, where trade practice is restricted to the use of U.S. customary units, some requirements in Handbook 44 may only specify U.S. Customary units until the NCWM achieves a broad consensus on the permitted SI units. In this case, since these equivalent “units” are not actual recognized, traceable units of measure, this may not create a conflict, but OWM wants to be sure that the legality of metric units is understood. Additionally, caution should be taken to avoid a situation where the dispenser is set to measure in kilograms, but the dispenser is marked with an equivalent unit based on gallons rather than on liters since this would lead to consumer confusion.

With respect to the differences between the S&T and L&R proposals, OWM has developed a table titled “Discrepancies in the 2015 CNG and LNG S&T and L&R Proposals to Change HB 44 and HB130” and included it at the end of its analysis of this agenda item. The table provides recommendations based on the assumption that the

S&T proposals reflect the preferences of both Committees -- which may or may not be the case -- based on input received at the NCWM Interim Meeting and discussions among the two Committees. That is, to remedy any conflicts in the two proposals, it is suggested that the L&R HB 130 proposals be further modified to align that language with the corresponding S&T proposals for changes to language in HB 44.

With respect to the proposal’s current provision of allowing states the option of choosing between mass units and volume equivalent units, OWM is concerned that if adopted, this might have the effect of dividing the country into a patchwork of different areas where natural gas dispensed as an engine fuel is offered for sale and sold in one of two acceptable methods, depending on each state’s preference for one of those methods. If a state chooses to allow both units, such confusion could also arise among competing businesses in the same state. If this were to occur, consumers in need of purchasing the product, especially those who regularly travel over state lines, such as interstate truckers, could find it very difficult to make value comparisons of the product when having to refuel in different parts of the country that offer the product for sale in different, yet, legally-acceptable units.

OWM notes, too, that whereas the current proposal addresses the marking of supplemental fuel comparison information on the dispenser, neither the S&T or L&R proposals address the posting of advertised prices on street signs visible from the road, which are most often used by consumers in deciding where to refuel. Thus, the refueling stations in one particular state could advertise prices by the pound on the street sign, whereas, the refueling stations in one or more of the states adjoining it could advertise prices by volume equivalent units on the street sign. These two differing, yet, seemingly acceptable means of advertising might favor the refueling stations in some states over others just by virtue of the units in which the prices are advertised. Believing that the current proposal might pose a conflict with a key NIST OWM responsibility (i.e., to promote uniform standards of weights and measures to facilitate commerce), OWM continues to support the sale of natural gas by mass; permitting information on equivalent energy “units” to be displayed as “supplemental fuel comparison information.”

***LNG Code Development – Additional Work.***

Additional work is needed to modify NIST Handbook 44 to fully recognize LNG applications so that there is a uniform basis for inspection/test and type approval procedures. Currently, the only mention of LNG is in NIST HB 44 Section 3.34 Cryogenic Liquid-Measuring Devices Code in paragraph A.2.(c) which specifies that the code does not apply to devices used solely for dispensing LNG. Given an LNG RMFD may be equipped with either mass flow metering or possibly other measurement technology, the application of multiple codes might occur in the test and inspection of these devices. NIST is developing a plan to present to the community for the development of proposed requirements to address LNG measuring devices.

***Additional Action Needed if the Current Proposal is Adopted.***

Some States were encouraged to enact legislation that included specific DGE values for both CNG (6.380 lb) and LNG (6.06 lb) in their laws and regulations and may already have installations in use where fuel deliveries are in equivalent units. These jurisdictions should revisit their policies and field sites to determine if the fuel equivalent values conflict with those included (CNG 6.384 lb and LNG 6.059 lb) in the proposals before the July 2015 NCWM. The system allows for differences so that a jurisdiction can meet its special local needs, so we expect there will be exceptions and slight variations, but not to the designated value of a measurement unit. This work should be done in conjunction with other state and local regulators that overlap in regulating a commodity and represent different facets of the industry (suppliers, equipment OEMs, fuel tax bureau, etc.) to provide due process and disseminate information about tentative and approved code requirements.



This publication is available free of charge from: <https://doi.org/10.6028/NIST.SP.1210>

<b>Discrepancies in the 2015 CNG and LNG S&amp;T and L&amp;R Proposals to Change HB 44 and HB 130</b>	
The recommendations listed below identify changes needed to the L&R proposals to align them with those in the S&T proposals. This makes the assumption that the S&T proposals reflect the preferences of both Committees -- which may or may not be the case. The following changes would remedy any conflicts between the S&T and L&R proposals and align the proposed changes to HB 44 with proposed changes to HB 130.	
232-4 V Section 2.27 Retail Sales of Natural Gas Sold as a Vehicle Fuel	
2.27.1.2 Gasoline...(GLE)	S&T is deleting all references to the term “gasoline liter equivalent (GLE)” and any corresponding definition for GLE in HB 44. This was done to avoid perpetuating or creating new non-traceable SI equivalent units.
2.27.1.4. Diesel ...(DLE)	S&T does not propose to include a definition for the term “diesel liter equivalent (DLE)” in its corresponding Agenda Item 337-1. This was done to avoid perpetuating or creating new non-traceable SI equivalent units. Remove the term “diesel liter equivalent (DLE)” from the HB 130 paragraph.
2.27.2.1. Method of ....Sale	S&T proposes to delete all references to the term GLE and any corresponding definition for GLE in HB 44. S&T does not include a new definition for the term “diesel liter equivalent” in its corresponding Agenda Item 337-1. Remove both terms from the HB 130 paragraph.
2.27.2.2. Dispenser Labeling....Gas	S&T does not propose to include a new definition for the term “diesel liter equivalent (DLE)” in its corresponding Agenda Item 337-1. This was to avoid perpetuating or creating new non-traceable SI equivalent units. Remove the term diesel liter equivalent (DLE) from the HB 130 paragraph.
2.27.2.3 Method....Sale	S&T does not propose to include a new definition for the term “diesel liter equivalent” in its corresponding Agenda Item 337-1. This was to avoid perpetuating or creating new non-traceable SI equivalent units. Remove the term “diesel liter equivalent (DLE)” from the HB 130 paragraph.
2.27.2.4. Dispenser Labeling...Gas	S&T will not include a new definition for the term diesel liter equivalent in its corresponding Agenda Item 337-1. This was done to avoid perpetuating or creating new non-traceable SI equivalent units. Remove the term diesel liter equivalent (DLE) from the HB 130 paragraph.
237-1 V .... Section 3.11 ....Compressed Natural Gas (CNG)	
3.11.2.2.2. Conversion Factor	Keep most of the current HB 130 text, but delete the text “either,” and “1 Gasoline Liter Equivalent (GLE) is equal to 0.678 kg of Natural Gas,” and amend the word “statements” to singular form. S&T is deleting all references to the term GLE and any corresponding definition for GLE in HB 44. This was done to avoid perpetuating or creating new non-traceable SI equivalent.
337-1 V Appendix D.... Natural Gas	
Item Title	Delete “DLE” from the title; it is no longer being addressed even though prior to January 2015 the term was being proposed as a new unit.
gasoline gallon equivalent (GGE)	The proposed HB 44 definition for “GGE” does not recognize SI mass units; whereas the definition for “GGE” in HB 130 specifies in 2.27.1.3. that the term “means 2.567 kg (5.660 lb).” As written, the HB 44 proposal does not meet the HB mandate to promote the SI system.

## Appendix H

### Item 360-5:

#### Electric Vehicle Fueling and Submetering Draft Code

This draft code replaces the version of the code included in the Committee’s 2014 Final Report. This version was developed by the USNWG and has been reviewed and forwarded to NCWM by each of the regional associations for national consideration. The submitter, the USNWG, and all four regionals propose that this version be considered for voting in July 2015.

### Draft NIST Handbook 44 Device Code Requirements for Electric Vehicle Fueling Systems

#### SECTION 3.40. ELECTRICITY-MEASURING DEVICES – TENTATIVE CODE

This tentative code has only a trial or experimental status and is not intended to be enforced. The requirements are designed for study prior to the development and adoption of a final code. Officials wanting to conduct an official examination of an Electric Vehicle Supply Equipment (EVSE) or system are advised to see paragraph G-A.3. Special and Unclassified Equipment.

(Tentative Code Added 20XX)

#### A. APPLICATION

**A.1. General.** – This code applies to devices, accessories, and systems used for the measurement of electricity dispensed in vehicle fuel applications wherein a quantity determination or statement of measure is used wholly or partially as a basis for sale or upon which a charge for service is based.

**A.2. Exceptions.** – This code does not apply to:

- (a) The use of any measure or measuring device owned, maintained, and used by a public utility or municipality only in connection with measuring electricity subject to the authority having jurisdiction such as the Public Utilities Commission.
- (b) Electric Vehicle Supply Equipment (EVSEs) used solely for dispensing electrical energy in connection with operations in which the amount dispensed does not affect customer charges or compensation.
- (c) The wholesale delivery of electricity.

**A.3. Additional Code Requirements.** – In addition to the requirements of this code, Electricity-Measuring Devices shall meet the requirements of Section 1.10. General Code.

**A.3.1. Electric Vehicle Supply Equipment (EVSE) with Integral Time-Measuring Devices.** – An EVSE that is used for both the sale of electricity as vehicle fuel and used to measure time during which services (e.g., vehicle parking) are received. These devices shall also meet the requirements of Section 5.55. Timing Devices.

**A.4. Type Evaluation.** – The National Type Evaluation Program (NTEP) will accept for type evaluation only those EVSEs that comply with all requirements of this code and have received safety certification by a Nationally Recognized Testing Laboratory (NRTL).

## S. SPECIFICATIONS

### S.1. Primary Indicating and Recording Elements.

**S.1.1. Electric Vehicle Supply Equipment (EVSE).** – An EVSE used to charge electric vehicles shall be of the computing type and shall indicate the electrical energy, the unit price, and the total price of each transaction.

- (a) EVSEs capable of applying multiple unit prices over the course of a single transaction shall also be capable of indicating the start and stop time, the total quantity of energy delivered, the unit price, and the total price for the quantity of energy delivered during each discrete phase corresponding to one of the multiple unit prices.
- (b) EVSEs capable of applying additional fees for time-based and other services shall also be capable of indicating the total time measured; the unit price(s) for the additional time based service(s); the total computed price(s) for the time measured; and the total transaction price, including the total price for the energy and all additional fees.

**S.1.2. EVSE Indicating Elements.** – An EVSE used to charge electric vehicles shall include an indicating element that accumulates continuously and displays, for a minimum of 15 seconds at the activation by the user and at the start and end of the transaction, the correct measurement results relative to quantity and total price. Indications shall be clear, definite, accurate, and easily read under normal conditions of operation of the device. All indications and representations of electricity sold shall be clearly identified and separate from other time-based fees indicated by an EVSE that is used for both the sale of electricity as vehicle fuel and the sale of other separate time-based services (e.g., vehicle parking).

**S.1.2.1. Multiple EVSEs Associated with a Single Indicating Element** - A system with a single indicating element, for two or more EVSEs, shall be provided with means to display information from the individual EVSE(s) selected or displayed, and shall be provided with automatic means to indicate clearly and definitely which EVSE is associated with the displayed information.

#### S.1.3. EVSE Units.

**S.1.3.1. EVSE Units of Measurement.** –EVSEs used to charge electric vehicles shall be indicated and recorded in megajoules (MJ) or kilowatt-hours (kWh) and decimal subdivisions thereof.

**S.1.3.2. EVSE Value of Smallest Unit.** – The value of the smallest unit of indicated delivery by an EVSE, and recorded delivery, if the EVSE is equipped to record, shall be 0.005 MJ or 0.001 kWh.

**S.1.3.3. Values Defined.** – Indicated values shall be adequately defined by a sufficient number of figures, words, symbols, or combinations thereof. An indication of “zero” shall be a zero digit for all displayed digits to the right of the decimal mark and at least one to the left.

### S.2. EVSE Operating Requirements.

#### S.2.1. EVSE Return to Zero.

- (a) The primary indicating and the primary recording elements of an EVSE used to charge electric vehicles, if the EVSE is equipped to record, shall be provided with a means for readily returning the indication to zero either automatically or manually.
- (b) It shall not be possible to return primary indicating elements, or primary recording elements, beyond the correct zero position.

**S.2.2. EVSE Indicator Zero Reset Mechanism.** – The reset mechanism for the indicating element of an EVSE used to charge electric vehicles shall not be operable during a transaction. Once the zeroing operation has begun, it shall not be possible to indicate a value other than the latest measurement, or “all zeros,” blank the indication, or provide other indications that cannot be interpreted as a measurement during the zeroing operation.

**S.2.3. EVSE Provision for Power Loss.**

**S.2.3.1. Transaction Information.** – In the event of a power loss, the information needed to complete any transaction (i.e., delivery is complete and payment is settled) in progress at the time of the power loss (such as the quantity and unit price, or sales price) shall be determinable through one of the means listed below or the transaction shall be terminated without any charge for the electrical energy transfer to the vehicle:

- at the EVSE;
- at the console, if the console is accessible to the customer;
- via on site internet access; or
- through toll-free phone access.

For EVSEs in parking areas where vehicles are commonly left for extended periods, the information needed to complete any transaction in progress at the time of the power loss shall be determinable through one of the above means for at least eight hours.

**S.2.3.2. Transaction Termination.** – In the event of a power loss, either: (a) the transaction shall terminate at the time of the power loss; or (b) the EVSE may continue charging without additional authorization if the EVSE is able to determine it is connected to the same vehicle before and after the supply power outage. In either case, there must be a clear indication on the receipt provided to the customer of the interruption, including the date and time of the interruption along with other information required under S.2.6. EVSE Recorded Representations.

**S.2.3.3. User Information.** – The EVSE memory, or equipment on the network supporting the EVSE, shall retain information on the quantity of fuel dispensed and the sales price totals during power loss.

**S.2.4. EVSE Indication of Unit Price and Equipment Capacity and Type of Voltage.**

**S.2.4.1. Unit Price.** – An EVSE shall be able to indicate on each face the unit price at which the EVSE is set to compute or to dispense at any point in time during a transaction.

**S.2.4.2. Equipment Capacity and Type of Voltage.** – An EVSE shall be able to conspicuously indicate on each face the maximum rate of energy transfer (i.e., maximum power) and type of current associated with each unit price offered (e.g., 7 kW AC, 25 kW DC, etc.).

**S.2.4.3. Selection of Unit Price.** – When electrical energy is offered for sale at more than one-unit price through an EVSE, the selection of the unit price shall be made prior to delivery through a deliberate action of the purchaser to select the unit price for the fuel delivery. Except when the conditions for variable price structure have been approved by the customer prior to the sale, a system shall not permit a change to the unit price during delivery of electrical energy.

**Note:** When electrical energy is offered at more than one-unit price, selection of the unit price may be through the deliberate action of the purchaser: 1) using controls on the EVSE; 2) through the purchaser’s use of personal or vehicle mounted electronic equipment communicating with the system; or 3) verbal instructions by the customer.

**S.2.4.4. Agreement Between Indications.** – All quantity, unit price, and total price indications within a measuring system shall agree for each transaction.

**S.2.5. EVSE Money-Value Computations.** – An EVSE shall compute the total sales price at any single-purchase unit price for which the electrical energy being measured is offered for sale at any delivery possible within either the measurement range of the EVSE or the range of the computing elements, whichever is less.

**S.2.5.1. Money-Value Divisions Digital.** – An EVSE with digital indications shall comply with the requirements of paragraph G-S.5.5. Money-Values, Mathematical Agreement, and the total price computation shall be based on quantities not exceeding 0.5 MJ or 0.1 kWh.

**S.2.5.2. Auxiliary Elements.** – If a system is equipped with auxiliary indications, all indicated money value and quantity divisions of the auxiliary element shall be identical with those of the primary element.

**S.2.6. EVSE Recorded Representations.** – a receipt providing the following information shall be available through a built-in or separate recording element at the completion of all transactions:

- (a) the total quantity of the energy delivered with unit of measure;
- (b) the total computed price of the energy sale;
- (c) the unit price of the energy; (for systems capable of applying multiple unit prices for energy during a single transaction, the following additional information is required):
  - (1) the start and stop time of each phase during which one of the multiple unit prices was applied;
  - (2) the unit price applied during each phase;
  - (3) the total quantity of energy delivered during each phase;
  - (4) the total purchase price for the quantity of energy delivered during each phase;
- (d) the maximum rate of energy transfer (i.e., maximum power) and type of current (e.g., 7 kW AC, 25 kW DC, etc.);
- (e) any additional separate charges included in the transaction (e.g., charges for parking time) including:
  - (1) the time and date when the service ends and the time and date when the service begins; or the total time interval purchased, and the time and date that the service either begins or ends;
  - (2) the unit price applied for the time-based service;
  - (3) The total purchase price for the quantity of time measured during the complete transaction;
- (f) the final total price of the complete transaction including all items;
- (g) the unique EVSE identification number;
- (h) the business name; and
- (i) the business location.

For systems equipped with the capability to issue an electronic receipt, the customer may be given the option to receive the receipt electronically (e.g., via cell phone, computer, etc.).

**S.2.7. Indication of Delivery.** – The EVSE shall automatically show on its face the initial zero condition and the quantity delivered (up to the capacity of the indicating elements).

**S.3. Design of Measuring Elements and Measuring Systems.**

**S.3.1. Metrological Components.** – An EVSE measuring system shall be designed and constructed so that metrological components are adequately protected from environmental conditions likely to be detrimental to accuracy. The system shall be designed to prevent undetected access to adjustment mechanisms and terminal blocks by providing for application of a physical security seal or an audit trail.

**S.3.2. Terminals.** – The terminals of the EVSE system shall be arranged so that the possibility of short circuits while removing or replacing the cover, making connections, or adjusting the system, is minimized.

**S.3.3. Provision for Sealing.** – Adequate provision shall be made for an approved means of security (e.g., data change audit trail) or physically applying security seals in such a manner that no adjustment may be made of:

- (a) each individual measurement element;
- (b) any adjustable element for controlling voltage or current when such control tends to affect the accuracy of deliveries;
- (c) any adjustment mechanism that corrects or compensates for energy loss between the system and vehicle connection; and
- (d) any metrological parameter that detrimentally affects the metrological integrity of the EVSE or system.

When applicable, the adjusting mechanism shall be readily accessible for purposes of affixing a security seal. Audit trails shall use the format set forth in Table S.3.4. Categories of Device and Methods of Sealing.

This publication is available free of charge from: <https://doi.org/10.6028/NIST.SP.1210>

<b>Table S.3.4. Categories of Device and Methods of Sealing</b>	
<b>Categories of Device</b>	<b>Method of Sealing</b>
<p><b>Category 1:</b> No remote configuration capability.</p>	<p>Seal by physical seal or two event counters: one for calibration parameters and one for configuration parameters.</p>
<p><b>Category 2:</b> Remote configuration capability, but access is controlled by physical hardware.</p> <p>The device shall clearly indicate that it is in the remote configuration mode and record such message if capable of printing in this mode or shall not operate while in this mode.</p>	<p>The hardware enabling access for remote communication must be on-site. The hardware must be sealed using a physical seal or an event counter for calibration parameters and an event counter for configuration parameters. The event counters may be located either at the individual measuring EVSE or at the system controller; however, an adequate number of counters must be provided to monitor the calibration and configuration parameters of the individual EVSEs at a location. If the counters are located in the system controller rather than at the individual EVSE, means must be provided to generate a hard copy of the information through an on-site device.</p>
<p><b>Category 3:</b> Remote configuration capability access may be unlimited or controlled through a software switch (e.g., password).</p> <p>The device shall clearly indicate that it is in the remote configuration mode and record such message if capable of printing in this mode or shall not operate while in this mode.</p>	<p>An event logger is required in the device; it must include an event counter (000 to 999), the parameter ID, the date and time of the change, and the new value of the parameter. A printed copy of the information must be available through the EVSE or through another on-site device. The event logger shall have a capacity to retain records equal to 10 times the number of sealable parameters in the EVSE, but not more than 1000 records are required. (<b>Note:</b> Does not require 1000 changes to be stored for each parameter.)</p>

**S.3.4. Data Storage and Retrieval.**

- (a) EVSE data accumulated and indicated shall be unalterable and accessible.
- (b) Values indicated or stored in memory shall not be affected by electrical, mechanical or temperature variations, radio-frequency interference, power failure, or any other environmental influences to the extent that accuracy is impaired.
- (c) Memory and/or display shall be recallable for a minimum of three years. A replaceable battery shall not be used for this purpose.

**S.3.5. Temperature Range for System Components.** – EVSEs shall be accurate and correct over the temperature range of – 40 °C to + 85 °C (– 40 °F to 185 °F). If the system or any measuring system components are not capable of meeting these requirements, the temperature range over which the system is capable shall be stated on the NTEP CC, marked on the EVSE, and installations shall be limited to the narrower temperature limits.

**S.4. Connections.**

**S.4.1. Diversion of Measured Electricity.** – No means shall be provided by which any measured electricity can be diverted from the measuring device.

**S.4.1.1. Unauthorized Disconnection.** – Means shall be provided to automatically terminate the transaction in the event that there is an unauthorized break in the connection with the vehicle.

**S.4.2. Directional Control.** – If a reversal of energy flow could result in errors that exceed the tolerance for the minimum measured quantity, effective means, automatic in operation to prevent or account for the reversal of flow shall be properly installed in the system. (See N.3. Minimum Test Draft (Size).)

**S.5. Markings.** – The following identification and marking requirements are in addition to the requirements of Section 1.10 General Code, paragraph G-S.1. Identification.

**S.5.1. Location of Marking Information; EVSE.** – The marking information required in General Code, paragraph G-S.1. Identification shall appear as follows:

- (a) within 60 cm (24 in) to 150 cm (60 in) from ground level;
- (b) on a portion of the EVSE that cannot be readily removed or interchanged (e.g., not on a service access panel).

**S.5.2. EVSE Identification and Marking Requirements.** – In addition to all the marking requirements of Section 1.10 General Code, paragraph G-S.1. Identification, each EVSE shall have the following information conspicuously, legibly, and indelibly marked:

- (a) voltage rating;
- (b) maximum current deliverable;
- (c) type of current (AC or DC or, if capable of both, both shall be listed);
- (d) minimum measured quantity (MMQ); and
- (e) temperature limits, if narrower than and within  $-20\text{ }^{\circ}\text{C}$  to  $+50\text{ }^{\circ}\text{C}$  ( $-4\text{ }^{\circ}\text{F}$  to  $122\text{ }^{\circ}\text{F}$ ).

**S.5.3. Abbreviations and Symbols.** – The following abbreviations or symbols may appear on an EVSE system.

- (a) VAC = Volts Alternating Current;
- (b) VDC = Volts Direct Current;
- (c) MDA = maximum deliverable amperes;
- (d) J = Joule.

**S.6. Printer.** – When assembly system is equipped with means for printing the measured quantity, the printed information must agree with the indications on the EVSE for the transaction and the printed values shall be clearly defined.

**S.6.1. Printed Receipt.** – Any delivered, printed quantity shall include an EVSE identification number that uniquely identifies the EVSE from all other EVSEs within the seller's facility, the time and date, and the name of the seller. This information may be printed by the EVSE system or pre-printed on the ticket.

**S.7. Totalizers for EVSE Systems.** – EVSE systems shall be designed with a nonresettable totalizer for the quantity delivered through each separate measuring device. Totalizer information shall be adequately protected and unalterable. Totalizer information shall be provided by the system and readily available on site or via on site internet access.



**S.8. Minimum Measured Quantity.** – The minimum measured quantity shall satisfy the conditions of use of the measuring system as follows:

- (a) Measuring systems shall have a minimum measured quantity not exceeding 2.5 MJ or 0.5 kWh.

## N. NOTES

**N.1. No Load Test.** – A no load test may be conducted on an EVSE measuring system by applying rated voltage to the system under test and no load applied.

**N.2. Starting Load Test.** – A system starting load test maybe conducted by applying rated voltage and 0.5 ampere (A) load.

**N.3. Minimum Test Draft (Size).** – Full and light load tests shall require test of the EVSE System for a delivery of the minimum measured quantity as declared by the manufacturer.

**N.4. EVSE System Test Loads.** – EVSE measuring system testing shall be accomplished by connecting the test load and test standard at the point where the fixed cord is connected to the vehicle. Losses in the cord between the meter under test and the test standard should be automatically corrected for in the EVSE quantity indication for direct comparison to the test standard and also while the EVSE is in normal operation. For EVSEs that require a customer supplied cord, system testing shall be accomplished by connecting the test load and test standard at the point where the customer’s cord is connected to the EVSE.

### N.5. Test of an EVSE System.

**N.5.1. Performance Verification in the Field** – Testing in the field is intended to validate the transactional accuracy of the EVSE system. The following testing is deemed sufficient for field a validation.

**N.5.2. Accuracy Testing** – The testing methodology compares the total energy delivered in a transaction and the total cost charged as displayed/reported by the EVSE with that measured by the measurement standard.

(a) For AC systems:

- (1) Accuracy test of the EVSE system at a load of not less than 85 percent of the maximum deliverable current (MDA) as determined from the pilot signal for a total energy delivered of at least twice the minimum measured quantity (MMQ). If the MDA would result in maximum deliverable power of greater than 7.2 kW, then the test may be performed at 7.2 kW.
- (2) Accuracy test of the EVSE system at a load of not greater than 10 percent of the maximum deliverable current (MDA) as determined from the pilot signal for a total energy delivered of at least the minimum measured quantity (MMQ).

(b) For DC systems (see note):

- (1) Accuracy test of the EVSE system at a load of not less than 85 percent of the maximum deliverable current (MDA) as determined from the pilot signal for a total energy delivered of at least twice the minimum measured quantity (MMQ).
- (2) Accuracy test of the EVSE system at a load of not more than 10 % of the maximum deliverable current (MDA) as determined from the pilot signal for a total energy delivered of at least the minimum measured quantity (MMQ).

**Note:** For DC systems it is anticipated that an electric vehicle may be used as the test load. Under that circumstance testing at the load presented by the vehicle shall be sufficient.

**N.6. Repeatability Tests.** – Tests for repeatability should include a minimum of three consecutive tests at the same load, similar time period, etc. and be conducted under conditions where variations in factors are reduced to minimize the effect on the results obtained.

## T. TOLERANCES

### T.1. Tolerances, General.

- (a) The tolerances apply equally to errors of underregistration and errors of overregistration.
- (b) The tolerances apply to all deliveries measured at any load within the rated measuring range of the EVSE.
- (c) Where instrument transformers or other components are used, the provisions of this section shall apply to all system components.

### T.2. Load Test Tolerances.

**T.2.1. EVSE Load Test Tolerances.** – The tolerances for EVSE load tests are Acceptance Tolerance: 1.0 % and Maintenance Tolerance: 2.0 %.

**T.3. Repeatability.** – When multiple load tests are conducted at the same load condition, the range of the load test results shall not exceed 25 % of the absolute value of the maintenance tolerance and the results of each test shall be within the applicable tolerance.

**T.4. Tolerance Application in Type Evaluation Examinations for EVSEs.** – For type evaluation examinations, the acceptance tolerance values shall apply under the following conditions:

- (a) at any temperature, voltage, load, and power factor within the operating range of the EVSE, and
- (b) regardless of the influence factors in effect at the time of the conduct of the examination, and
- (c) for all quantities greater than the minimum measured quantity.

**T.5. No Load Test.** – An EVSE measuring system shall not register when no load is applied.

**T.6. Starting Load.** – An EVSE measuring system shall register starting load test at a 0.5 ampere (A) load.

## UR. USER REQUIREMENTS

### UR.1. Selection Requirements.

**UR.1.1. Computing-Type Device; Retail EVSE.** – An EVSE used to charge electric vehicles shall be of the computing type and shall indicate the electrical energy, the unit price, and the total price of each delivery.

**UR.1.2. Connection Cord-Length.** – An adequate means for cord management shall be in use when the cord exceeds 25 ft in length.

### UR.2. Installation Requirements.

**UR.2.1. Maximum Deliverable Current.** – The marked maximum deliverable current shall not exceed the total capacity in amperes of the EVSE or the thermal overload protectors of the installation site.

**UR.2.2. Manufacturer’s Instructions.** – An EVSE shall be installed in accordance with the manufacturer’s instructions, and the installation shall be sufficiently secure and rigid to maintain this condition.

**UR.2.3. Load Range.** – An EVSE shall be installed so that the current and voltage will not exceed the rated maximum values over which the EVSE is designed to operate continuously within the specified accuracy. Means to limit current and/or voltage shall be incorporated in the installation if necessary.

**UR.2.4. Regulation Conflicts and Permit Compliance.** – If any provision of Section UR.2. Installation Requirements is less stringent than that required of a similar installation by the serving utility, the installation shall be in accordance with those requirements of the serving utility.

The installer of any EVSE shall obtain all necessary permits.

**UR.2.5. Responsibility, Unattended EVSE.** – An unattended EVSE shall have clearly and conspicuously displayed thereon, or immediately adjacent thereto, adequate information detailing the name, address, and phone number of the local responsible party for the device.

### **UR.3. Use of EVSE.**

**UR.3.1. Unit Price for Retail EVSE Devices.** – The unit price at which the EVSE is set to compute shall be conspicuously displayed or posted on the face of a retail EVSE used in direct sale.

**UR.3.2. Return of Indicating and Recording Elements to Zero.** – The primary indicating elements (visual) and the primary recording elements shall be returned to zero immediately before each transaction.

**UR.3.3. Printed Ticket.** –A receipt providing the following information shall be available through a built-in or separate recording element at the completion of all transactions:

- (a) the total quantity of the energy delivered with unit of measure;
- (b) the total computed price of the energy sale;
- (c) the unit price of the energy; (for systems capable of applying multiple unit prices for energy during a single transaction, the following additional information is required):
  - (1) the start and stop time of each phase during which one of the multiple unit prices was applied;
  - (2) the unit price applied during each phase;
  - (3) the total quantity of energy delivered during each phase;
  - (4) the total purchase price for the quantity of energy delivered during each phase;
- (d) the maximum rate of energy transfer (i.e., maximum power) and type of current (e.g., 7 kW AC, 25 kW DC, etc.);
- (e) any additional separate charges included in the transaction (e.g., charges for parking time) including:
  - (1) the time and date when the service ends and the time and date when the service begins; or the total time interval purchased, and the time and date that the service either begins or ends;
  - (2) the unit price applied for the time-based service;
  - (3) The total purchase price for the quantity of time measured during the complete transaction;

- (f) the final total price of the complete transaction including all items;
- (g) the unique EVSE identification number;
- (h) the business name; and
- (i) the business location.

For systems equipped with the capability to issue an electronic receipt, the customer may be given the option to receive the receipt electronically (e.g., via cell phone, computer, etc.).

**UR.3.4. EVSE in Operation.** – The EVSE shall be permanently, plainly, and visibly identified so that it is clear which EVSE and connector is in operation.

**UR.3.5. Steps After Charging.** – After delivery to a customer from a retail EVSE:

- (a) the EVSE shall be shut-off at the end of a charge, through an automatic interlock that prevents subsequent charging until the indicating elements and recording elements, if the EVSE is equipped and activated to record, have been returned to their zero positions; and
- (b) the vehicle connector shall not be returned to its starting position unless the zero set-back interlock is engaged or becomes engaged by the act of disconnecting from the vehicle or the act of returning the connector to the starting position.

## HANDBOOK 44, APPENDIX D – DEFINITIONS

The specific code to which the definition applies is shown in [brackets] at the end of the definition. Definitions for the General Code [1.10.] apply to all codes in Handbook 44.

### A

**active (real) power.** – The component of electric power that performs work, typically measured in kilowatts (kW) or megawatts (MW). Also known as “real power.” The terms “active” or “real” power are used to modify the base term “power” to differentiate it from reactive and apparent power. The active power ( $P_{ac}$ ) or real power measured by a system, is the product of voltage (E) times current (I) times the cosine of the angle by which the current lags the voltage ( $\cos \phi$ ) or power factor (pf).  $P_{ac} = (E) (I) (\cos \phi)$  where  $\phi$  is the phase angle of the lag. [3.XX]

**alternating current (AC).** – An electric current that reverses direction in a circuit at regular intervals. [3.XX]

**ampere.** – The practical unit of electric current. It is the quantity of current caused to flow by a potential difference of one volt through a resistance of one ohm. One ampere is equal to the flow of one coulomb of charge per second. One coulomb is the unit of electric charge equal in magnitude to the charge of  $6.24 \times 10^{18}$  electrons. [3.XX]

**apparent power.** – The product of the RMS current (I) and the RMS voltage (E) in a circuit. [3.XX]

**audit trail.** – An electronic count and/or information record of the changes to the values of the calibration or configuration parameters of a device. [1.10, 2.20, 2.21, 2.24, 3.30, 3.37, 3.39, 3.XX, 5.56(a)]

(Added 1993)

### B

**balanced load.** – Balanced load is used to indicate equal currents in all phases and relatively equal voltages between phases and between each phase and neutral (if one exists); with approximately equal watts in each phase of the load. [3.XX]

**basic lightning impulse insulation level (BIL).** – A specific insulation level expressed in kilovolts of the crest value of a standard lightning impulse. (Example: BIL = 10 Kv). [3.XX]

**burden (B).** – The impedance of the circuit connected to the instrument transformer's secondary winding. (Example: B = 21 Ohms Max). [3.XX]

## C

**calibration parameter.** – Any adjustable parameter that can affect measurement or performance accuracy and, due to its nature, needs to be updated on an ongoing basis to maintain device accuracy (e.g., span adjustments, linearization factors, and coarse zero adjustments). [2.20, 2.21, 2.24, 3.30, 3.37, 3.39, 3.XX, 5.56(a)]

(Added 1993)

**central location.** – A laboratory or shop used for the testing of systems to measure in-service accuracy. [3.XX]

**configuration parameter.** – Any adjustable or selectable parameter for a device feature that can affect the accuracy of a transaction or can significantly increase the potential for fraudulent use of the device and, due to its nature, needs to be updated only during device installation or upon replacement of a component (e.g., division value[increment], sensor range, and units of measurement). [2.20, 2.21, 2.24, 3.30, 3.37, 3.XX, 5.56(a)]

(Added 1993)

**connection line impedance.** – The impedance of the circuit used to convey energy sold from a fueling device to the storage of an electric vehicle. [3.XX]

**creep.** – A continuous apparent measurement of energy indicated by a system with operating voltage applied and no power consumed (load terminals open circuited). [3.XX]

**current.** – The rate of the flow of electrical charge past any one point in a circuit. The unit of measurement is amperes or coulombs per second. [3.XX]

## D

**direct current (DC).** – an electric current that flows in one direction.

## E

**electric vehicle, plug-in.** – A vehicle that employs electrical energy as a primary or secondary mode of propulsion. Plug-in electric vehicles may be all-electric vehicles (EV's) or plug-in hybrid electric vehicles (PHEV's). All-electric vehicles are powered by an electric motor and battery at all times. All-electric vehicles may also be called battery-electric vehicles (BEV's). Plug-in hybrid electric vehicles employ both an electric motor and an internal combustion engine that consumes either conventional or alternative fuel or a fuel cell. In a parallel type hybrid-electric vehicle, either the electric motor or the engine may propel the vehicle. In a series type hybrid-electric vehicle, the engine or fuel cell generates electricity that is then used by the electric motor to propel the vehicle. EV's, BEV's, and PHEV's are capable of receiving and storing electricity via connection to an external electrical supply. Not all hybrid-electric vehicles are of the plug-in type. Hybrid-electric vehicles that do not have the capability to receive electrical energy from an external supply (HEV's) generate electrical energy onboard with the internal combustion engine, regenerative braking, or both. [3.XX]

**electric vehicle supply equipment (EVSE).** – A device or system designed and used specifically to transfer electrical energy to an electric vehicle, either as charge transferred via physical or wireless connection, by loading a fully charged battery, or by other means. [3.XX]

**electricity as vehicle fuel.** – Electrical energy transferred to and/or stored onboard an electric vehicle primarily for the purpose of propulsion. [3.XX]

**electricity meter.** – A device that measures and registers the integral of an electrical quantity with respect to time.[3.XX]

**element (stator).** – A combination of a voltage-sensing unit and a current-sensing unit, which provides an output proportional to the quantities measured. [3.XX]

**energy.** – The integral of active power with respect to time. [3.XX]

**energy flow.** – The flow of energy between line and load terminals (conductors) of an electricity system. Flow from the line to the load terminals is considered energy delivered. Energy flowing in the opposite direction (i.e., from the load to line terminals) is considered as energy received. [3.XX]

**equipment, commercial.** – Weights, measures, and weighing and measuring devices, instruments, elements, and systems or portion thereof, used or employed in establishing the measurement or in computing any basic charge or payment for services rendered on the basis of weight or measure. As used in this definition, measurement includes the determination of size, quantity, value, extent, area, composition (limited to meat and poultry), constituent value (for grain), or measurement of quantities, things, produce, or articles for distribution or consumption, purchased, offered, or submitted for sale, hire, or award. [1.10, 2.20, 2.21, 2.22, 2.24, 3.30, 3.31, 3.32, 3.33, 3.34, 3.35, 3.38, 3.XX, 4.40, 5.51, 5.56.(a), 5.56.(b), 5.57, 5.58, 5.59]

(Added 2008)

**event counter.** – A nonresettable counter that increments once each time the mode that permits changes to sealable parameters is entered and one or more changes are made to sealable calibration or configuration parameters of a device. [2.20, 2.21, 3.30, 3.37, 3.39, 3.XX, 5.54, 5.56(a), 5.56(b), 5.57]

(Added 1993)

**event logger.** – A form of audit trail containing a series of records where each record contains the number from the event counter corresponding to the change to a sealable parameter, the identification of the parameter that was changed, the time and date when the parameter was changed, and the new value of the parameter. [2.20, 2.21, 3.30, 3.37, 3.39, 3.XX, 5.54, 5.56(a), 5.56(b), 5.57]

(Added 1993)

**EVSE field reference standard.** – A portable apparatus that is traceable to NIST and is used as a standard to test EVSEs in commercial applications. This instrument is also known as a portable standard or working standard. [3.XX]

## F

**face.** – That portion of a computing-type pump or dispenser which displays the actual computation of price per unit, delivered quantity, and total sale price. In the case of some electronic displays, this may not be an integral part of the pump or dispenser. [3.30, 3.XX]

(Added 1987)

**form designation (FM).** – An alphanumeric designation denoting the circuit arrangement for which the meter is applicable and its specific terminal arrangement. The same designation is applicable to equivalent meters for all manufacturers. (Example: FM 2S) [3.XX]

## H

**hertz (Hz).** – Frequency or cycles per second. One cycle of an alternating current or voltage is one complete set of positive and negative values of the current or voltage. [3.XX]

## I

**instrument transformer ratio.** – The stated ratio of the primary circuit current or voltage compared to the secondary circuit current or voltage. (Example: CTR = 200 : 0.1) [3.XX]

## J

**megajoule (MJ).** – An SI unit of energy equal to 1,000,000 joules. [3.XX]

## K

**kilowatt (kW).** – A unit of power equal to 1,000 watts. [3.XX]

**kilowatt-hour (kWh).** – A unit of energy equal to 1,000 watthours. [3.XX]

## L

**line service.** – The service terminals or conductors connecting the EVSE to the power source. [3.XX]

**load service.** – The service terminals or conductors connecting the EVSE to the electrical load (e.g., vehicle, tenant, etc.). [3.XX]

**load, full.** – A test condition with rated voltage, current at 100 % of test amps level, and power factor of 1.0. [3.XX]

**load, light.** – A test condition with rated voltage, current at 10 % of test amps level, and power factor of 1.0. [3.XX]

## M

**master meter, electric.** – An electric watthour meter owned, maintained, and used for commercial billing purposes by the serving utility. All the electric energy served to a submetered service system is recorded by the master meter. [3.XX]

**meter, electricity.** – An electric watthour meter. [3.XX]

**metrological components.** – Elements or features of a measurement device or system that perform the measurement process or that may affect the final quantity determination or resulting price determinations. This includes accessories that can affect the validity of transactions based upon the measurement process. The measurement process includes determination of quantities; the transmission, processing, storage, or other corrections or adjustments of measurement data or values; and the indication or recording of measurement values or other derived values such as price or worth or charges. [3.XX]

## N

**nationally recognized testing laboratory (NRTL).** – A laboratory that conducts testing and certification that is recognized by OSHA. [3.XX]

**nonresettable totalizer.** – An element interfaced with the measuring or weighing element that indicates the cumulative registration of the measured quantity with no means to return to zero. [3.30, 3.37, 3.39, 3.XX]

## O

**ohm.** – The practical unit of electric resistance that allows one ampere of current to flow when the impressed potential is one volt. [3.XX]

## P

**percent registration.** – Percent registration is calculated as follows:

$$\text{Percent Registration} = \frac{\text{Wh measured by EVSE}}{\text{Wh measured by STANDARD}} \times 100$$

[3.XX]

**percent error.** – Percent Error = Percent Registration – 100. A system is said to be “slow” that has percent registration below 100 % and negative percent error. [3.XX].

**point-of-sale system.** – An assembly of elements including a weighing or measuring element, an indicating element, and a recording element (and may also be equipped with a “scanner”) used to complete a direct sales transaction. [2.20, 3.30, 3.32, 3.37, 3.39, 3.XX]

(Added 1986) (Amended 1997)

**power factor.** – The ratio of the active power to the apparent power in an AC circuit. The power factor is a number between 0 and 1 that is equal to 1 when the voltage and current are in phase (load is entirely resistive). [3.XX]

**primary indicating or recording elements.** – The term “primary” is applied to those principal indicating (visual) elements and recording elements that are designed to, or may, be used by the operator in the normal commercial use of a device. The term “primary” is applied to any element or elements that may be the determining factor in arriving at the sale representation when the device is used commercially. (Examples of primary elements are the visual indicators for meters or scales not equipped with ticket printers or other recording elements and both the visual indicators and the ticket printers or other recording elements for meters or scales so equipped.) The term “primary” is not applied to such auxiliary elements as, for example, the totalizing register or predetermined-stop mechanism on a meter or the means for producing a running record of successive weighing operations, these elements being supplementary to those that are the determining factors in sales representations of individual deliveries or weights. (See “indicating element” and “recording element.”) [1.10, 3.XX]

(Amended 20XX)

**primary watthour constant (PK<sub>h</sub>).** – The meter watthour constant per revolution or pulse (K<sub>h</sub>) multiplied by the product of the current and/or voltage transformer ratio(s):

$$PK_h = K_h (\text{Current Transformer Ratio} \times \text{Voltage Transformer Ratio})$$

[3.XX]

## R

**reactive power.** – For sinusoidal quantities in a two-wire circuit, reactive power is the product of the voltage, the current, and the sine of the phase angle between them, using the current as the reference. [3.XX]

**recorded representation.** – The printed, electronically recorded, or other representation that retains a copy of the quantity and any other required information generated by a weighing or measuring device. [1.10, 3.XX]



**recording element.** – An element incorporated, connected to, or associated with ~~in~~ a weighing or measuring device by means of which its performance relative to quantity or money value is permanently recorded in a printed or electronic form. [1.10, 3.XX]

**remote configuration capability.** – The ability to adjust a weighing or measuring device or change its sealable parameters from or through some other device that is not itself necessary to the operation of the weighing or measuring device or is not a permanent part of that device. [2.20, 2.21, 2.24, 3.30, 3.37, 3.39, 3.XX, 5.56(a)]

(Added 1993)

**retail device.** – A measuring device primarily used to measure electrical energy for the purpose of sale to the end user. [3.30, 3.32, 3.37, 3.39, 3.XX]

(Amended 1987, ~~and~~ 2004, and 20XX)

**revolution equivalent.** – The number of watthours represented by one increment (pulse period) of serial data. [3.XX]

**root mean square (RMS).** – The mathematical convention used to describe the average quantity of a property (such as current) that is varying as a sine wave. [3.XX]

## S

**serving utility.** – The utility distribution company that owns the master meter and sells electric energy to the owner of a submeter system. [3.XX]

**starting load.** – The minimum load above which the device will indicate energy flow continuously. [3.XX]

**submeter.** – A system furnished, owned, installed, and maintained by the customer who is served through a utility owned master meter. [3.XX]

## T

**tenant.** – The person or persons served electric energy from a submetered service system. [3.XX]

**test accuracy – in-service.** – The device accuracy determined by a test made during the period that the system is in service. It may be made on the customer's premises without removing the system from its mounting, or by removing the EVSE for testing either on the premises or in a laboratory or shop. [3.XX]

**test amperes (TA).** – The full load current (amperage) specified by the EVSE manufacturer for testing and calibration adjustment. (Example: TA 30) [3.XX]

**test block.** – Device that facilitates safe meter testing by disconnecting the meter from the circuit without interrupting the service to the tenant. [3.XX]

**thermal overload protector.** – A circuit breaker or fuse that automatically limits the maximum current in a circuit. [3.XX]

## U

**unit price.** – The price at which the electrical energy is being sold and expressed in whole units of measurement. [1.10, 3.30, 3.XX]

(Added 1992)

## V

**vehicle connector.** – A device that by insertion into a vehicle inlet, establishes an electrical connection to the electric vehicle for the purpose of providing power and information exchange, with means for attachment of electric vehicle cable. This device is a part of the vehicle coupler.

**vehicle coupler.** – A means enabling the connection, at will, of an electric vehicle cable to the equipment. It consists of a vehicle connector and a vehicle inlet.

**vehicle inlet.** – The part incorporated in, or fixed to the vehicle, which receives power from a vehicle connector.

**volt.** – The practical unit of electromotive force. One volt will cause one ampere to flow when impressed across a resistance of one ohm. [3.XX]

**voltage transformer.** – A device that provides a secondary voltage that is a precise fraction of the primary voltage. [3.XX]

## W

**watt.** – The practical unit of electric power. In an alternating-current circuit (AC), the power in watts is volts times amperes multiplied by the circuit power factor. [3.XX]

**watthour (Wh).** – The practical unit of electric energy, which is expended in one hour when the average power consumed during the hour is one watt. [3.XX]

**watthour – test constant (K<sub>t</sub>).** – The expression of the relationship between the energy applied to the meter system and corresponding occurrence of one test output indication expressed as watthours per test output indication. [3.XX]

THIS PAGE INTENTIONALLY LEFT BLANK

## Appendix I

### Item 360-5:

#### Electric Vehicle Fueling and Submetering

These proposed changes to Handbook 44, Section 5.55. Timing Devices Code are from the USNWM on EVFS and have been reviewed and forwarded to NCWM by each of the regional associations for national consideration. The submitter, the USNWG, and all four regionals propose that these changes be considered for Voting in July 2015.

### SECTION 5.55. TIMING DEVICES

#### A. APPLICATION

**A.1. General.** – This code applies to devices used to measure time during which services are being dispensed (such as vehicle parking, laundry drying, and car washing). **This code also applies to Electric Vehicle Supply Equipment (EVSE) when used to assess charges for time-based services in addition to those charged for electrical energy.**

**A.2. Additional Code Requirements.** – In addition to the requirements of this code, Timing Devices shall meet the requirements of Section 1.10. General Code.

#### S. SPECIFICATIONS

##### S.1. Design of Indicating and Recording Elements and of Recorded Representations.

###### S.1.1. Primary Elements.

**S.1.1.1. General.** – A timing device shall be equipped with a primary indicating element, and may also be equipped with a primary recording element. **A timing device incorporated into an Electric Vehicle Supply Equipment system for use in assessing charges for timing separate from charges for electrical energy shall be equipped with the capability to provide a recorded representation of the transaction through a built-in or separate recording element.** A readily observable in-service light or other equally effective means that automatically indicates when laundry driers, vacuum cleaners, and car washes are in operation shall be deemed an appropriate primary indicating element.

(Amended 1979)

**S.1.1.2. Units.** – A timing device shall indicate and record, if the device is equipped to record, the time in terms of minutes for time intervals of 60 minutes or less and in hours and minutes for time intervals greater than 60 minutes.

**S.1.1.3. Value of Smallest Unit.** – The value of the smallest unit of indicated time and recorded time, if the device is equipped to record, shall not exceed the equivalent of:

- (a) one-half hour on parking meters indicating time in excess of two hours;
- (b) six minutes on parking meters indicating time in excess of one but not greater than two hours; or
- (c) five minutes on all other devices, except those equipped with an in-service light.

(Amended 1975)

**S.1.1.4. Advancement of Indicating and Recording Elements.** – Primary indicating and recording elements shall be susceptible to advancement only during the mechanical operation of the device, except that clocks may be equipped to manually reset the time.

**S.1.1.5. Operation of In-Service Indicator Light.** – For devices equipped with an in-service light indicator, the in-service light indicator shall be operative only during the time the device is in operation.

**S.1.1.6. Discontinuous Indicating Parking Meters.** – An indication of the time purchased shall be provided at the time the meter is activated in units of no more than one minute for times less than one hour and not more than two minutes for times of one hour or more. Convenient means shall be provided to indicate to the purchaser the unexpired time.

(Added 1975) (Amended 1976)

## **S.1.2. Graduations.**

**S.1.2.1. Length.** – Graduations shall be so varied in length that they may be conveniently read.

**S.1.2.2. Width.** – In any series of graduations, the width of a graduation shall in no case be greater than the width of the minimum clear interval between graduations and the width of main graduations shall be not more than 50 % greater than the width of subordinate graduations. Graduations shall in no case be less than 0.2 mm (0.008 in) in width.

**S.1.2.3. Clear Interval Between Graduations.** – The clear interval shall be not less than 0.75 mm (0.03 in). If the graduations are not parallel, the measurement shall be made:

- (a) along the line of relative movement between the graduations at the end of the indicator; or
- (b) if the indicator is continuous, at the point of widest separation of the graduations.

## **S.1.3. Indicators.**

**S.1.3.1. Symmetry.** – The index of an indicator shall be symmetrical with respect to the graduations, at least throughout that portion of its length associated with the graduations.

**S.1.3.2. Length.** – The index of an indicator shall reach to the finest graduations with which it is used, unless the indicator and the graduations are in the same plane, in which case the distance between the end of the indicator and the ends of the graduations, measured along the line of the graduations, shall be not more than 1.0 mm (0.04 in).

**S.1.3.3. Width.** – The width of the index of an indicator in relation to the series of graduations with which it is used shall be not greater than:

- (a) the width of the widest graduation; and
- (b) the width of the minimum clear interval between the graduations.

**S.1.3.4. Parallax.** – Parallax effect shall be reduced to a practicable minimum.

## **S.1.4. ~~Printed Tickets~~ Recorded Representations.**

**S.1.4.1. Timing Devices, Electric Vehicle Supply Equipment.** – A timing device incorporated into an EVSE for use in assessing charges for timing separate from charges for electrical energy shall issue a recorded representation itemizing the charges for these services as defined in Section 3.XX. Electricity-Measuring Devices.

**S.1.4.1.1. Duplicate Receipts. – Duplicate receipts are permissible, provided the word “duplicate” or “copy” is included on the receipt.**

**S.1.4.2. All other Timing Devices.** – A printed ticket issued or stamped by a timing device shall have printed clearly thereon:

- (a) the time and day when the service ends and the time and day when the service begins, except that a self-service money-operated device that clearly displays the time of day need not record the time and day when the service begins; or
- (b) the time interval purchased, and the time and day that the service either begins or ends.

(Amended 1983)

**S.2. Marking Requirements, Operating Instructions.** – Operating instructions shall be clearly stated on the device.

**S.3. Interference.** – The design of the EVSE shall be such that there will be no interference between the time and electrical energy measurement elements of the system.

**S.4. Provisions for Sealing.** – Adequate provisions shall be made to provide security for the timing element.

**S.5. Power Interruption.** – In the event of a power loss, the information needed to complete any transaction (i.e., delivery is complete and payment is settled) in progress at the time of the power loss (such as the quantity and unit price, or sales price) shall be determinable through one of the means listed below or the transaction shall be terminated without any charge for the electrical energy transfer to the vehicle. :

- at the EVSE;
- at the console, if the console is accessible to the customer;
- via on site internet access; or
- through toll-free phone access.

**For EVSEs in parking areas where vehicles are commonly left for extended periods, the information needed to complete any transaction in progress at the time of the power loss shall be determinable through one of the above means for at least 8 hours.**

**S.5.1. Transaction Termination.** – In the event of a power loss, either: (a) the transaction shall terminate at the time of the power loss; or (b) the EVSE may continue charging without additional authorization if the EVSE is able to determine it is connected to the same vehicle before and after the supply power outage . In either case, there must be a clear indication on the receipt provided to the customer of the interruption, including the date and time of the interruption along with other information required under S.1.4.2. Recorded Representation; All Other Timing Devices.

**S.5.2. User Information.** – The EVSE memory, or equipment on the network supporting the EVSE, shall retain information on the quantity of time and the sales price totals during power loss.

## N. NOTES

**N.1. Test Method.** – A timing device shall be tested with a timepiece with an error of not greater than plus or minus 15 seconds per 24-hour period. In the test of timing devices with a nominal capacity of 1 hour or less, stopwatches with a minimum division of not greater than one-fifth second shall be used. In the test of timing devices with a nominal capacity of more than one hour, the value of the minimum division on the timepiece shall be not greater than

one second. Time pieces and stopwatches shall be calibrated with standard time signals as described in National Institute of Standards and Technology Special Publication 432, NIST Time and Frequency Dissemination Services, or any superseding publication.

(Amended 1978)

**N.2. Broadcast Times and Frequencies.** – Time and frequency standards are broadcast by the stations listed in Table N.2. Broadcast Times and Frequencies.

<b>Table N.2.* Broadcast Times and Frequencies</b>			
<b>Station</b>	<b>Location, Latitude, Longitude</b>	<b>Frequency (MHz)</b>	<b>Times of Transmission (UTC)</b>
WWV	Fort Collins, Colorado 40E41' N 105E02' W	2.5 5.0 10.0	Continuous
WWVH	Kauai, Hawaii 21E59' N 159E46' W	2.5 5.0 10.0 15.0	Continuous
CHU	Ottawa, Canada 45E18' N 75E45' W	3.330 7.335 14.670 14.670	Continuous

\*From NIST Special Publication 559, “Time and Frequency Users’ Manual,” 1990.

(Added 1988)

**N.3. Interference Tests, EVSE – On an EVSE equipped with a timing device used to calculate time-based charges in addition to any charges assessed for electrical energy, a test shall be conducted to ensure that there is no interference between time and electrical energy measuring elements.**

## T. TOLERANCES

**T.1. Tolerance Values.** – Maintenance and acceptance tolerances for timing devices shall be as follows:

**T.1.1. For Timing Devices Other Than Those Specified in T.1.2. For Time Clocks and Time Recorders and T.1.3. On Parking Meters.** – The maintenance and acceptance tolerances shall be:

(a) On Overregistration: 5 seconds for any time interval of 1 minute or more; and  
 (Amended 1986)

(b) On Underregistration: 6 seconds per indicated minute.  
 (Amended 1975)

**T.1.2. For Time Clocks and Time Recorders.** – The maintenance and acceptance tolerances on over-registration and underregistration shall be three seconds per hour, but not to exceed one minute per day.  
 (Amended 1975)

**T.1.3. On Parking Meters and Other Timing Devices Used to Assess Charges for Parking.** – The maintenance and acceptance tolerances are shown in Table T.1.3. Maintenance and Acceptance Tolerances for Parking Meters and Other Timing Devices Used to Assess Charges for Parking.

Table T.1.3. Maintenance and Acceptance Tolerances for Parking Meters and Other Timing Devices Used to Assess Charges for Parking		
Maintenance and Acceptance Tolerances		
Nominal Time Capacity	On Overregistration	On Underregistration
30 minutes or less	No tolerance	10 seconds per minute, but not less than 2 minutes
Over 30 minutes to and including 1 hour	No tolerance	5 minutes plus 4 seconds per minute over 30 minutes
Over 1 hour	No tolerance	7 minutes plus 2 minutes per hour over 1 hour

**T.2. Tests Involving Digital Indications or Representations.** – To the tolerances that would otherwise be applied, there shall be added an amount equal to one-half the minimum value that can be indicated or recorded.

#### UR. USER REQUIREMENTS

**UR.1. Statement of Rates.** – The following information shall be clearly, prominently, and conspicuously displayed:

- (a) ~~€~~The price in terms of money per unit or units of time for the service dispensed; and
- (b) for a timing device other than an EVSE, the number of coins the device will accept and be activated by at one time ~~shall be clearly, prominently and conspicuously displayed.~~

(Amended 1976) (Amended 20XX)

**UR.2. Time Representations.** – Any time representation shall be within plus or minus two minutes of the correct time in effect in the area, except on an individual clock used only for “time out”; in addition, the time indication of the “time-out” clock shall be the same as or less than that of the “time-in” clock.

(Amended 1975)

For quick reference in reviewing this document, below is a definition copied from Appendix D for “overregistration and underregistration.” A way to remember this is if a device is “overregistering,” it is showing “over” or more than the amount that is showing on the standard. Note that zero tolerance is allowed on “overregistration” for parking charges because a consequence of showing that more time has elapsed than actually has occurred could be a parking violation for the driver of the vehicle.

**overregistration and underregistration.** – When an instrument or device is of such a character that it indicates or records values as a result of its operation, its error is said to be in the direction of overregistration or underregistration, depending upon whether the indications are, respectively, greater or less than they should be. Examples of devices having errors of “overregistration” are: a fabric-measuring device that indicates more than the true length of material passed through it; and a liquid-measuring device that indicates more than the true amount of the liquid delivered by the device. Examples of devices having errors of “underregistration” are: a meter that indicates less than the true amount of product that it delivers; and a weighing scale that indicates or records less than the true weight of the applied load. [1.10]



THIS PAGE INTENTIONALLY LEFT BLANK

## Report of the Professional Development Committee (PDC)

Cheryl Ayer, Committee Chair  
New Hampshire

### 400 INTRODUCTION

This is the report of the Professional Development Committee (PDC) (hereinafter referred to as the “Committee”) for the 100<sup>th</sup> Annual Meeting of the National Conference on Weights and Measures (NCWM) held in Philadelphia, PA, July 19 - 23, 2015. This report is based on the Interim Report offered in the NCWM Publication 16, “Committee Reports,” testimony at public hearings, comments received from the regional weights and measures associations and other parties, the addendum sheets issued at the Annual Meeting, and actions taken by the membership at the voting session of the Annual Meeting. The Informational items shown below were adopted as presented when this report was approved.

Table A identifies the agenda items by reference key, title of item, page number and the appendices by appendix designations. The acronyms for organizations and technical terms used throughout the agenda are identified in Table B. The first three digits of an item’s reference key are assigned from the Subject Series List. The status of each item contained in the report is designated as one of the following: **(D) Developing Item:** the Committee determined the item has merit; however, the item was returned to the submitter or other designated party for further development before any action can be taken at the national level; **(I) Informational Item:** the item is under consideration by the Committee but not proposed for Voting; **(V) Voting Item:** the Committee is making recommendations requiring a vote by the active members of NCWM; **(W) Withdrawn Item:** the item has been removed from consideration by the Committee.

Table C provides a summary of the results of the voting on the Committee’s items and the report in its entirety. Some Voting Items are considered individually; others may be grouped in a consent calendar. Consent calendar items are Voting Items that the Committee has assembled as a single Voting Item during their deliberation after the Open Hearings on the assumption that the items are without opposition and will not require discussion. The Voting Items that have been grouped into consent calendar items will be listed on the addendum sheets. Prior to adoption of the consent calendar, the Committee will entertain any requests from the floor to remove specific items from the consent calendar to be discussed and voted upon individually.

Proposed revisions to the handbook(s) are shown as follows: 1) deleted language is indicated with a **bold face font using strikeouts** (e.g., ~~this report~~), and 2) proposed new language is indicated with an **underscored bold faced font** (e.g., new items). When used in this report, the term “weight” means “mass”.

**Note:** The policy is to use metric units of measurement in all of its publications; however, recommendations received by NCWM technical committees and regional weights and measures associations have been printed in this publication as submitted. Therefore, the report may contain references to U.S. customary units.

**Subject Series List**

Introduction .....	400 Series
Education.....	410 Series
Program Management.....	420 Series

**Table A  
Table of Contents**

Reference Key	Title of Item	PDC Page
<b>400</b>	<b>INTRODUCTION .....</b>	<b>1</b>
<b>410</b>	<b>EDUCATION.....</b>	<b>3</b>
410-1	I Professional Certification Program .....	3
410-2	I Training.....	7
410-3	I Instructor Improvement.....	8
410-4	I Recommended Topics for Conference Training .....	11
<b>420</b>	<b>PROGRAM MANAGEMENT .....</b>	<b>13</b>
420-1	I Safety Awareness.....	13
420-2	I PDC Publication.....	15

**Appendix**

<b>A</b>	<b>Safety Awareness Presentation.....</b>	<b>A1</b>
----------	---	-----------

**Table B  
Glossary of Acronyms and Terms**

Acronym	Term	Acronym	Term
ADDIE	Analysis, Design, Development, Implementation, and Evaluation	NEWMA	Northeastern Weights and Measures Association
ANSI	American National Standards Institute	NIST	National Institute of Standards and Technology
BOK	Body of Knowledge	OWM	Office of Weights and Measures
CWMA	Central Weights and Measures Association	PDC	Professional Development Committee
ISO	International Standardization Organization	RSA	Registered Service Agents
ICE	Institute for Credentialing Excellence	SME	Subject Matter Expert
NCWM	National Conference on Weights and Measures	SWMA	Southern Weights and Measures Association
		WWMA	Western Weights and Measures Association

**Table C**  
**Voting Table**

<i>Reference Key Number</i>	<i>House of State Representatives</i>		<i>House of Delegates</i>		<i>Results</i>
	<i>Yeas</i>	<i>Nays</i>	<i>Yeas</i>	<i>Nays</i>	
To accept the Report	Voice Vote				Adopted

**Details of All Items**  
*(In order by Reference Key)*

**410 EDUCATION**

**410-1 I Professional Certification Program**

Professional certifications are offered in many industries as a means of demonstrating competence in a particular field of expertise. Certification may be a means of qualifying an individual for employment or a higher pay grade within a profession. The NCWM Professional Certification Program provides confidence that an individual has a strong understanding of U.S weights and measures standards as adopted by NCWM and published in NIST Handbook 44, “Specifications, Tolerances, and Other Technical Requirements for Weighing and Measuring Devices,” NIST Handbook 130, “Uniform Laws and Regulations in the Areas of Legal Metrology and Engine Fuel Quality,” and NIST Handbook 133, “Checking the Net Contents of Packaged Goods.”

Professional certification is available to NCWM members and non-members in the private sector and in government positions. Please note the person taking the test must be an NCWM member in order to take the exams for free.

Three new exams were deployed in 2015. These include Medium Capacity Scales, Large Capacity Scales, and Vehicle-Tank Meters. Mr. Ross Andersen, the NCWM Certification Coordinator will provide statistical analysis of test results at the 2016 NCWM Interim Meeting. The Committee thanks the subject matter experts who have invested their time in the successful completion of these exams. Their names are listed in the table below.

Vehicle Tank Meters	Medium Capacity Scales Large Capacity Scales
Conrad Brown, ME	Mark Buccelli, MN, Retired
Charles Carroll, MA	Jim Daggon, Rice lake Weighing
Gabe Frezzo, Industry, PA	Dennis Fox, Central Illinois Scale
Lewis Hutfles, KS	Nathan Gardner, OR
Paul Jordan, CA	Joe Grell, Rice Lake Weighing
Antony Joseph, NY	Roger Macey, CA, Retired
John Kirk, VA	Matthew Maiten, Santa Barbara, CA
Gary Kneissel, MN	Mike Mann, WA
Mike Mann, WA	Albie Michelson, WY, Retired
Albie Michelson, WY, Retired	John Pasko, WI
Ron Pierce, PA	Kevin Pfeiffer, VA
Gary Sassaman, Liquid Measures & Controls, PA	Doug Rudy, PA
Scott Simmons, CO	Mike Smith, NY
Mike Smith, NY	Richard Suiter, NE, NIST, Retired
Michael Swimm, ME	Courtney Ward, Quality Scales
Jared Williams, WI	
Ray Woolfolk, AK	
Jane Zulkiewicz, Barnstable, MA	

The next exams to be completed will be Liquefied Petroleum Gas (LPG) and Price Verification, followed by Mass Flow Meters, Packaging and Labeling, and Precision Scales. Work has begun on the LPG exam and should begin shortly on Price Verification. The PDC is still looking for additional Subject Matter Expert (SME) volunteers for both of these projects. Any interested parties should contact the Mr. Andersen. The SME volunteers are the real heart of the certification program. The successful creation of these exams is dependent on willing volunteers.

**Status of Current Tests:**

NCWM has issued 310 professional certificates from inception of the Professional Certification Program to September 30, 2014. Of the certificates issued, six have been issued to individuals in the private sector (three for small scales, two for package checking, and one for retail motor-fuel dispensers). The balance of the certificates has been issued to regulators in 30 different states.

**Number of Certificates NCWM has issue by 2014 Fiscal Year End (September 30<sup>th</sup>):**

	FY10-11	FY11-12	FY12-13	FY13-14
<b>Count in Year</b>	44	94	104	68
<b>Cugmulative</b>	44	138	242	310

**States with largest number of Certificates:**

State	Certificates	State	Certificates
Missouri	56	Maine	8
Minnesota	52	Massachusetts	8
Maryland	47	New York	8
Nebraska	26	Ohio	8
Washington	24	Virginia	8
California	21	Idaho	6
Mississippi	15	Wisconsin	6
Connecticut	14	Wyoming	6
Arkansas	11	Private Industry	6

The Committee is continually working to improve the exams and the exam experience. Our goal is to make sure the exams stay meaningful and current as handbook changes are made, and they include an annual review of the current exams by the Certification Coordinator. The Committee reported that a short entry survey is being added to each exam to capture meta-data on who is taking the exams. Examples of meta-data include the candidate's level of experience; whether the candidate is a regulatory official or a service agent and so forth. The questions are in an untimed, unscored portion of the exam. Personal data will not be used in any analysis using this information.

In order to obtain valuable feedback on the Certification Program, the Committee has begun work on an exit survey, which will be implemented using Survey Monkey. The questions on the survey will address the mechanics of taking the exam, preparation for taking the exam, and general feedback (e.g., How did the candidate react **to the content** of the exam, was it challenging, was it too easy, or did they feel the exam was fair?).

NCWM Director, Mr. Don Onwiler, challenged the Committee to look toward the future of the program and explore the following areas:

**Accreditation** – This would require meeting established standards as a certifying body.

**Proctoring Exams** – Should candidates be required to take exams in a state's weights and measures facility or through a private proctoring service?

**Examination Protocol** – Currently, candidates register for the exam and are permitted to make up to two attempts to pass the exam. If the candidate fails both attempts, he or she may reregister and get an additional two attempts. 1) Do we continue to allow two attempts for each registration fee? 2) Do we implement a mandatory waiting period for candidates who need to retake the exam after two failed attempts?

**Intermediate Exams** – Jurisdictions have expressed interest in using the NCWM exams in their registered service agent programs. Would it be beneficial to have exams that can serve as stepping stones toward reaching professional certification? The Committee will consider creating three exams: 1) basic measurement and use of NIST Handbook 44; 2) basic liquid measuring, and 3) basic weighing.

The Committee continues to hear from states that are interested in requiring professional certification for their registered service agents. Some states have expressed concern that service agents would not be able to pass the Professional Certification Exams. The Committee is challenged with either reducing the difficulty of the test for service agents or finding ways to better prepare the service agents to successfully pass the exams. In particular, can the states expect private service agencies to provide training to prepare their workers to pass the NCWM certification exams? What actions will the states with registered service programs have to undertake to ensure that these service agents are as qualified as state-trained officials to evaluate equipment for legal compliance?

At the 2015 Annual Meeting, the Committee met with the Board of Directors to discuss the creation of lower level exams for service agents. During the meeting, the Board encouraged the Committee to move forward with the development of Basic Competency Exams. The Committee had already discussed the idea of exams covering Basic Weighing and Basic Liquid Measuring. Each of these exams would have a NIST Handbook 44 component and a technical component for either Weighing or Liquid Measuring. The Committee recognizes this will require the development of new learning objectives for these exams. During open hearings, the Committee asked for feedback and guidance on the learning objectives.

The Committee heard comments from Mr. Brett Gurney (Utah). He wants to see separation between the exams for regulatory officials and service technicians. Mr. Jim Hewston (JA King) supports the work of the Committee noting that they have twelve service centers in eight states. He welcomes testing and wants to rise to the challenge.

During the 2015 Interim and Annual Meeting open hearings, the Committee heard from multiple jurisdictions regarding how they have used the professional certification exams to help develop their inspectors. The Committee heard from four of the top five states who use the program including: Maryland, Minnesota, Missouri, and Washington. Jurisdictions shared various strategies they use, including the following:

- promoting professional certification at all staffing levels;
- incorporating certification exams into job classification requirements;
- using collective success on the certification exams as a measure of the effectiveness of the jurisdiction's training program;
- retesting to maintain their proficiency; and
- identify and implement additional training.

Mr. Ron Hayes (Missouri) commented that in addition to preparing employees with technical training, they also coach their employees on successful test-taking strategies. For example, avoiding getting caught up on one question and watching the time limit. Mr. Hayes also provides an environment to his employees that is free from interruption or outside influences.

The Committee will work with NCWM Headquarters to provide hyperlinks in the exam announcement to the EPOs, handbooks, supplemental courses, and study aids, including modules. This will provide quick access to individuals taking the exam as well as to trainers. EPOs updated to 2015 NIST Handbook 44 requirements have been posted on the NIST website.

### **Regional Associations Comments:**

The WWMA supports the continued development of the certification testing program and encourages more people to take the exams. The WWMA strongly recommends the NCWM devise a way to give individual participants feedback in those areas (i.e., General, Administration, or Technical) where they scored the lowest, while still maintaining the integrity of the Professional Certification Program.

NEWMA encourages the national Committee to continue efforts toward the development of stepping stone exams. When a new weights and measures official is employed, individuals are not able to work on their own until they reach a certain level of competence. When service agents apply for registration, they are generally not prepared to pass the professional certification exam. Basic stepping stone exams will be more appropriate for initial registration of service agents and help to verify they understand certain requirements before they begin placing devices into service. These exams could also be utilized for new weights and measures officials as a measure of increased competence during probation.

At the 2015 CWMA Annual Meeting, the Committee heard reinforcing comments that the majority thinks service agents should have a separate test. When asked what that test should cover, the following suggestions were received:

- How to look up items in NIST Handbook 44;
- How to look up, understand, and use NTEP Certificates of Conformance;
- Understanding the difference between calibrating (placing in service) and testing for tolerance; and

- Understanding the different responsibilities of service agents and regulators.

A suggestion was made that the National PDC should solicit states for their service agent tests in order to determine whether there are other areas which should also be included in the body of knowledge that service agents should know. The CWMA PDC also recommends that service agents should know how to properly seal all classes of devices.

The SWMA heard comments from Mr. Stratt Pinagel, Walmart, acknowledging the importance of these exams in promoting uniformity in inspections. Mr. Pinagel asked how many states are requiring successful completion of these exams as a condition for employment of inspectors. Dr. Matt Curran asked whether there were any states who are working toward implementing this in the future. Several states indicated they already require this and several, including Florida, indicate an active interest in pursuing this. Mr. Tim Chesser (Arkansas) indicated that although Arkansas would like to implement a requirement for inspectors to take these exams, Arkansas, like some other states, have personnel regulations that may prevent them from making this a requirement at the present time. He noted, however, that Arkansas is considering requiring this for service companies. Mr. Lou Straub, Fairbanks, noted that the “passing” rate for some of the exams is rather low and commented that if weights and measures officials are having difficulty passing the exams, this may pose a problem for service personnel who are less familiar with basic weights and measures requirements. Mr. Straub also suggested distinct tests for weights and measures officials and service personnel. Mr. Chesser pointed out that in Arkansas service personnel are performing many of the same inspection and testing functions as field officials; therefore, it is important they have a full understanding of the requirements. Mr. Dale Saunders (Virginia), SWMA PDC Chairman, commented that with regard to the exam scores, successful completion of these exams indicates a level of professional proficiency, and it is important that inspectors be prepared and undergo adequate training prior to taking these exams. After hearing Mr. Saunders’ comments, Mr. Jerry Butler (North Carolina) asked questions about how jurisdictions go about this preparation. Mr. Saunders noted this preparation is the basic training required of any inspector along with increased emphasis on studying and comprehending the NIST Handbook 44 requirements.

#### **410-2 I Training**

The purpose of this item is to share best practices and approaches to training in response to the broad training needs of weights and measures jurisdictions and to serve as a link to various training materials on the web.

At the 2014 Annual Meeting, the Committee announced the Model Field Training Program developed by a Subcommittee and chaired by Mr. Michael Cleary (California, retired), was available for use. To date, Mr. Cleary has given instruction on the use of the program to the WWMA and CWMA and is scheduled to give a presentation at the SWMA’s 2015 Annual Meeting. The Committee thanked the Associate Membership for sponsoring Mike’s presence at the regional meetings.

During the 2015 Annual Meeting, Mr. Cleary spoke about the training he provided at the regional meetings on the NCWM Model Field Training Program and stated his PowerPoint presentation from the CWMA meeting is available on the NCWM website at [http://www.ncwm.net/training/model\\_training](http://www.ncwm.net/training/model_training).

Mr. Cleary has received some positive feedback from regulators who have started using the Model Field Training Guide. The Committee hopes this guide will encourage jurisdictions that do not have an evaluation program in place to utilize this tool. As feedback has been received, minor changes have been made, and the updated document can be found under the training section of the NCWM website through the Training tab.

It is important to note that the combination of quality training and evaluation in a weights and measures program helps to ensure that jobs are done accurately and correctly. Again we thank Mr. Cleary, Subcommittee Chair, and all the Subcommittee members.

If you have any suggestions, recommendations, or you need support for successful implementation, please contact Mr. Cleary at (916) 483-8498 or by email at [mcleary55@sbcglobal.net](mailto:mcleary55@sbcglobal.net) or a member of the PDC.

A training video on retail motor-fuel dispensers was released by the NIST, Office of Weights & Measures. This video demonstrates and describes the minimum tests of a retail motor-fuel dispenser in accordance with NIST Handbook 44. It includes how to select and maintain a standard, wetting the standard, normal and slow flow tests, leveling, reading the meniscus, draining a test measure, and the anti-drain test. The video is available as a 14-minute video segment,



or it may be viewed in individual segments. The OWM will have a training video available on small capacity scales this year. OWM would like feedback on the training videos and input on training topics that jurisdictions would be interested in having available.

The Retail Motor Fuel Dispenser (RMFD) training video can be accessed from OWM’s home page at: <https://www.nist.gov/pml/weights-and-measures>. Select the “Legal Metrology Devices” link under “Programs.” On the “Legal Metrology Devices Program” page, click on “Training Materials” under “Related Links.” The NIST Handbook 44 Self-Study Course is also accessible on the “Training Materials” page. The PDC plans to provide links to these valuable training materials from the NCWM website under the “Training” tab.

**Regional Associations Comments:**

The WWMA supports the NCWM Model Field Training Program and encourages weights and measures jurisdictions to implement it. The WWMA conveys its gratitude to the NCWM work group headed by Mr. Cleary for developing the Model Field Training Program. This program provides the tools for the administrator and trainer to ensure that new inspectors are competent in all of the required basic skills needed to perform the function of an entry-level weights and measures official.

NEWMA would like to recognize the contributions made by the following agencies:

CONTRIBUTING AGENCY	CONTRIBUTION
NCWM	Training modules with uniform learning objectives
NCWM	Professional Certification Exam – Objectively measuring knowledge of the subject.
NIST, OWM	Train the Trainor Program
NIST, OWM	Training Course Materials
NIST, OWM	Training Videos and other Resources
STATES	Utilizing NCWM modules in training preparation
STATES	Utilizing NCWM certification exams to monitor employee progress
STATES	Sharing “trained” trainers with other states in the region

The NEWMA PDC heard remarks from Mr. Jerry Buendel (Washington) that many of the parts necessary to a national training program are coming together, and the program is just getting better and better.

SWMA heard a comment from Mr. Buendel that Mr. Cleary gave a very good presentation at the WWMA meeting on the Training Manual and suggested that Mr. Cleary be invited to give this presentation at the SWMA. Mr. Dale Saunders (Virginia, SWMA PDC Chairman) noted that Mr. Cleary was originally scheduled to give this presentation at the SWMA, but a schedule conflict prevented him from attending. Mr. Saunders reminded the SWMA that the PDC publications, including the manual, are available for viewing on the NCWM website.

**410-3 I Instructor Improvement**

NIST, OWM has provided legal metrology training for weights and measures jurisdictions and industry for many years but does not have the resources to respond to the numerous training requests it receives. NIST, OWM has long recognized that there are many individuals with extensive legal metrology experience who have the skills needed to provide this type of training, and in some cases, those individuals are already training within their own jurisdictions or regions. Drawing from this pool of individuals, NIST, OWM hopes to develop trainers who can present schools on behalf of NIST, thus leveraging NIST resources; providing access to NIST training on a timetable that can meet jurisdictions’ needs; and providing a way to more broadly share the valuable expertise these individuals possess.

Several years ago, NIST, OWM renewed its efforts to develop trainers by providing a grant to NCWM that is intended to pay travel costs of individuals to travel within their regions to conduct training and to participate in NIST training for trainers. This partnership has enabled NIST to bring in candidates for NIST-sponsored training such as “train the

trainer” classes and to participate in NIST technical training schools. Through an application process, in collaboration with weights and measures directors and nominated training candidates, NIST has identified a group of people who are now working with NIST to develop the knowledge, skills, and abilities to present specific technical schools on behalf of NIST. Candidates not only participate in “train the trainer” seminars, but also work with NIST, OWM staff to participate in technical training schools, assist in teaching seminars, and develop materials for use in NIST training schools.

The OWM is making progress on formalizing the NIST Instructor Training Program and expects to have formal criteria in place later in 2015. Key areas being addressed include:

- Instructor Competencies;
- Instructor Agreement;
- Feedback Mechanisms for Instructors; and
- Mentoring Plans.

The OWM is establishing a list of required “Instructor Competencies” for NIST, OWM trainers based on various models used in the adult training community and expects to finalize this list by fall 2015. OWM shared a preliminary list of competencies during the spring 2015 NIST Trainer Summit. Examples include:

- Technical knowledge (e.g., legal metrology expertise);
- Communication skills (e.g., writing, presentation, interpersonal skills);
- Consistency with NIST interpretations (e.g., presenting material consistent with other NIST instructors); and
- Knowledge and application of International Association for Continuing Education and Training (IACET) requirements.

NIST is authorized by IACET to issue “Continuing Education Units (CEUs),” and as part of this authorization, there are certain provisions that an instructor must follow in order to meet these requirements. NIST Certificates and the accompanying CEUs can only be issued if these criteria are met. OWM staff trainers have completed IACET training courses and are familiar with the procedures that OWM has implemented to ensure compliance with IACET-related requirements for NIST training courses. To ensure that external trainers in the NIST Trainer Program understand these provisions, OWM is planning to develop a series of short webinars that can be used to provide training to its external trainers.

In addition to refining the mechanisms used to collect feedback from students, NIST, OWM is looking for ways in which it can provide improved feedback to instructors on specific competency areas and assist them in identifying and setting goals to strengthen and develop their personal skills as trainers.

NIST training seminars on field inspection topics are held a limited number of times each year. This poses a challenge in sustaining regular interaction and involvement of NIST trainer candidates. NIST, OWM is considering how to ensure timely mentoring and continuity for individual instructors who will provide training on behalf of NIST. A number of candidates in the NIST Trainer Program have already served as co-instructors for NIST technical training schools and have done an excellent job. NIST, OWM sincerely appreciates the willingness of those trainers and their directors who have supported their participation to devote time to making these seminars successful.

A list of all people who have attended a “Train the Trainer” class has been posted on the NCWM website, whether or not they have worked with NIST as co-trainers or attended NIST technical training schools. The OWM has not certified anyone (external to NIST) as a “NIST Trainer” but looks forward to doing so once the structure of the Trainer Program is finalized and candidates have satisfied all requirements. At that point, a list of “NIST Trainers” will be posted along with the courses they are authorized to teach on behalf of NIST, OWM, and this list will be periodically updated as new trainers and technical areas are authorized. NIST does not have the resources to develop and sustain the development of all of the trainers it invites to participate in NIST trainer program activities and events; however, even if a candidate is not designated to present on behalf of NIST, they and their jurisdictions can benefit from the experience and the candidate can still provide valuable training in their jurisdiction and region.

NIST, OWM is also looking at ways to enhance and streamline its training and help prepare students *prior* to a training class. Students are currently required to complete a self-study course on NIST Handbook 44 prior to attending NIST device-related training seminars. NCWM has graciously agreed to offer an exam for this self-study course through the NCWM Certification Program system and is awaiting feedback from NIST on a beta version of the online exam. As an additional measure, NIST contracted with Mr. Henry Oppermann (W&M Consulting) who developed a Basic Measuring Course. NIST plans to offer this course as a self-study course and may require it as a prerequisite to participating in NIST seminars on measuring devices. NIST, OWM plans to develop a similar course for weighing devices.

NIST, OWM appreciates the strong support of NCWM, the PDC, the volunteer trainers, and their administrators in continuing to develop the NIST Trainer Program. OWM will continue to provide the Committee with updates on its progress.

The Committee continues to hear comments from states expressing appreciation for the NCWM Professional Certification Program and the NIST Training Program. The Committee also heard favorable comments about the training materials and tools provided by NIST, including a recent video on testing rRMFDs. As noted in Item 410-2, the NIST video is divided into segments focusing on specific parts of the RMFD test procedure that can be used to supplement and enhance instructor-led training. The video can be accessed through OWM's home page or by going directly to the following link:

**<https://www.nist.gov/pml/weights-and-measures/legal-metrology-devices/training-materials>**.

The Committee wants to reiterate that the responsibility for training employees rests with individual organizations (weights and measures jurisdictions and industry alike). While NIST and other training providers offer excellent sources of training and training materials, organizations must develop and manage their own training programs, including: developing trainers; establishing individual development plans for employees; and identifying strategies for continually assessing and responding to training needs.

The Committee recognizes that NIST, OWM cannot possibly train all of the weights and measures inspectors in the country. The state and municipal jurisdictions have ultimate responsibility for training and qualifying their personnel. To fulfill this responsibility, jurisdictions should be making individual plans to maintain or bolster their training efforts. NIST OWM should be viewed as one vital resource to support that effort. The Professional Development Committee is another resource. The Committee is creating, and posting on its website, the "Body of Knowledge" to establish uniform learning objectives for weights and measures professionals. In addition, the Committee has posted a Model Field Training Program document on its website. (See Item 410-2.) This program outlines methods to evaluate and document training and offers guidance on training new inspectors and taking steps to ensure their ongoing development.

All of these initiatives require competent and qualified trainers and a centralized management plan within the jurisdiction. The Committee is beginning work, in partnership with NIST, OWM, to identify the basic competencies of those trainers and training managers so jurisdictions can find the right people to manage and deliver training internally. It's not enough just to be technically competent in a subject area to be a good trainer or to effectively manage a training program. It takes other tools, such as:

- ability to assess employee competence and training needs;
- ability to create learning materials from technical material;
- ability to use adult learning techniques adapted to individual and group needs;
- ability to plan training activities and find appropriate training venues;
- ability to find creative ways to deliver training with tight budgets; and
- ability to adapt the overall training program to best serve jurisdiction goals.

#### **Regional Associations Comments:**

The WWMA commends Ms. Carol Hockert (NIST, OWM) and her staff for offering such a beneficial course to state and local weights and measures jurisdictions. The list of participants who have completed the Train-the-Trainer course

is available on the NCWM website. The WWMA encourages all weights and measures jurisdictions to take advantage of this valuable resource.

At the 2015 CWMA Annual Meeting, Ohio and Minnesota both indicated the regional training provided by NIST-trained trainers have been very valuable to their programs.

#### **410-4 I Recommended Topics for Conference Training**

The Board of Directors has charged the Committee with recommending appropriate topics for the technical sessions at future Annual Meetings. The Board of Directors asked the PDC to review and prioritize possible presentation topics and to submit this to the NCWM Chairman. The Chairman will coordinate with NCWM staff to secure presenters and schedule the sessions.

To date, the Committee has received suggestions for the following topics:

- Succession Planning;
- Small Volume Provers (including operation, use, and interpretation of the data);
- Job Safety;
- CNG;
- Making Sense of Electronic Receipts and Electronics Record Laws;
- Training the Trainer in Adult Learning Techniques;
- Ethics for Weights & Measures Officials;
- Data Privacy Issues Faced by Weights & Measures Officials;
- Guidelines for Supplemental Declarations (recommended by PALS);
- Alternative Fuels Issues (Fuel Volatility, Ethanol Blending, and Biodiesel Blend);
- Ergonomics (including Proper Lifting Techniques, Back and Stress Techniques, and Office Ergonomics);
- Public Relations (specifically dealing with aggressive/angry people) (recommended by the SWMA);
- General Safety Issues (recommended by the WWMA);
- Defensive Driving (recommended by the WWMA);
- Administrative Civil Penalty Process (recommended by the WWMA);
- Price Verification (recommended by the WWMA);
- Customer Service (recommended by the WWMA);
- Moisture Loss;
- Documenting Investigations for Court Proceedings;
- Honing Presentation Skills;
- Emerging Issues;
- Implementing New RMFD Price Posting and Computing Capability Revisions (recommended by the WWMA);
- Fundamentals of the National Type Evaluation Program (recommended by the WWMA);
- Electric Vehicles: Commercial Devices, Method of Sale, Advertising and Labeling (recommended by the WWMA);
- Understanding the International Weights and Measures Standards Development System (recommended by the WWMA); and

- Crane Operation and Safety (recommended by NEWMA).

Of these topics, the PDC recommends the following in order of priority:

- 1) Building a Safety Plan for your Organization;
- 2) Small Volume Provers (including operation, use, and interpretation of the data);
- 3) Electric Vehicles: an overview of the test procedure and test equipment; and
- 4) Public Relations: establishing and promoting good customer relations.

The following is a list of technical presentations made at NCWM since 2009. Presentations given since 2010 are available at [www.ncwm.net/meetings/annual/archive](http://www.ncwm.net/meetings/annual/archive).

- Motor Oil Quality Violations (Mr. Tom Glenn, Petroleum Quality Institute of America, 2014);
- Making Sense of Electronic Receipts (Mr. Justin Hotard, Vice President and General Manager, NCR Corporation, 2014);
- LNG & CNG Motor Fuel – A Technical Briefing from Industry (Mr. Doug Horne, President CVEF, Mr. Zack Wester, Blu, Mr. Jeff Clarke, NGVA, 2014);
- Taximeter Technology Advancements (Mr. Matt Daus, International Association of Transportation Regulators, 2013);
- Advanced Vehicles and Fuel Quality (Mr. John M Cabaniss, Jr., Association of Global Automakers, 2013);
- Economic Justification and Demonstrating Value of Weights and Measures (Mr. Tim Chesser, Arkansas Bureau of Standards, 2012);
- Conducting Effective Marketplace Surveys and Investigations (Ms. Judy Cardin, Wisconsin Weights and Measures, 2012);
- Public Relations and Customer Service as Regulators (Mr. Doug Deiman, Alaska Division of Measurement Standards/CVE, 2012);
- An Overview of Unit Pricing in the United States (Mr. David Sefcik, NIST OWM, 2011);
- Grocery Unit Pricing in Australia (Mr. Ian Jarratt, Queensland Consumers Association, 2011);
- Grocery Unit Pricing in Canada (Mr. Ian Jarratt, Queensland Consumers Association, 2011);
- The U.S. Hydrogen Measuring System: The Turning Point? (Ms. Kristin Macey, California Division of Measurement Standards, 2011);
- Corrosion in Ultra Low Sulfur Diesel Underground Storage Systems (Mr. Prentiss Searles and Ms. Lorri Grainawi, American Petroleum Institute, 2010);
- Risk-Based Inspection Schemes (Mr. Henry Oppermann, Weights and Measures Consulting, LLC, 2010);
- Diesel Exhaust Fluid (DEF) (Mr. Gordon Johnson, Gilbarco, Inc., and Mr. Randy Moses, Wayne, 2009);
- Fuel Volatility and Ethanol Blending (Mr. Jim McGetrick, BP Products, 2009);
- Investigative Techniques (Mr. Michael Cleary, Retired, 2009);
- Automatic Temperature Compensation (ATC) Field Test Procedures (Mr. Don Onwiler, Chair ATC Steering Committee, 2008);
- Elements of an Effective Safety and Health Program (Mr. Dan Whipple, OHST Vermont Department of Labor, 2008);
- Analyzing Temperature Compensation Data (Mr. Henry Oppermann, NIST, OWM, and Mr. Steven Malone, Nebraska Division of Weights and Measures, 2007);

- The Great Temperature Compensation Debate (Mr. Ross Andersen, New York Bureau of Weights and Measures, 2007); and
- NIST Handbook 44, Scale Code Tare Changes (Mr. Steve Cook, NIST OWM, XXXX DATE).

**Regional Associations Comments:**

WWMA recommends adding the following topic to the conference training list:

- Small Volume Provers Operation, Use, and Interpretation of the Data.

At the SWMA Annual Meeting, Mr. Dale Saunders, SWMA PDC Chairman, indicated that the NCWM PDC is looking for input from the SWMA on training topics of interest. He asked for people to provide comments to the SWMA PDC. He also indicated he is considering sending out a brief survey to the SWMA members on possible topics to forward to the NCWM PDC.

NEWMA recommends training on:

- “Job Safety” (recommendations for protecting employees and minimizing risks); and
- “CNG”

**420 PROGRAM MANAGEMENT**

**420-1 I Safety Awareness**

One of the goals of the PDC is to make a concerted effort to address and educate jurisdictions on safety awareness. It is important for us to open up dialog with the regions on safety awareness and know how to mitigate or eliminate safety issues. The Committee intends to use the safety page on the NCWM website (<https://www.ncwm.net/resource/safety>) as a place for states to share information and resources to help them address each of the major steps in creating and maintaining an effective safety program.

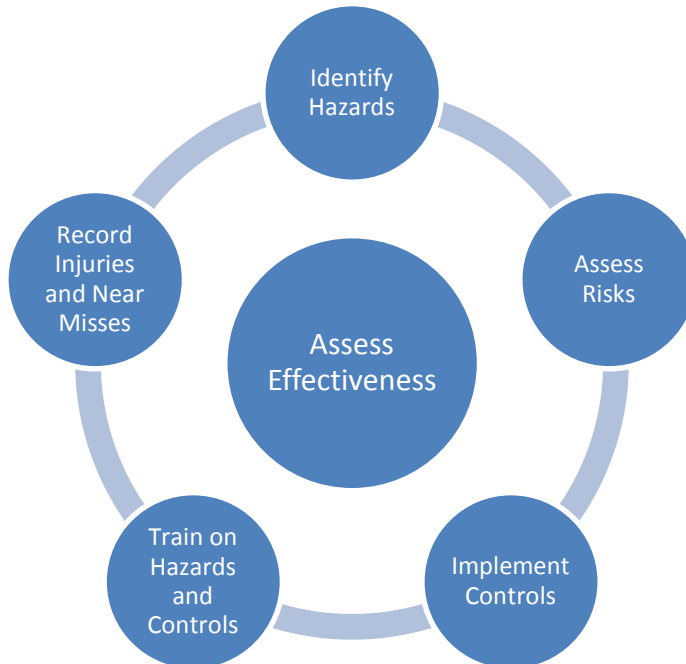

Sharing reports of incidents and near-misses can be one way for agencies to identify hazards, which they might otherwise overlook. Committee members Mr. Doug Killingsworth (Georgia) and Ms. Julie Quinn (Minnesota) have volunteered to work with the regional safety liaisons and other interested parties in compiling incident reports in a

systematic way to make them available on the safety page of the NCWM website. Please contact them if you are interested in assisting with this effort.

Other potential items for future inclusion on the safety page include links to resources on:

- OSHA consultation services;
- Job hazard analysis;
- Field level hazard analysis;
- Hierarchies of hazard control; and
- Safety training resources.

Each safety program is unique to its organization. Each agency is responsible for designing, implementing, and maintaining its own safety program. Resources provided on the web page are intended only to assist agencies as they develop and improve their own safety programs. Safety is not only first; it is first, last, and always. The work of maintaining and improving a safety program never ends.

Currently the safety page houses the list of regional safety liaisons and an archive of past safety articles. During the 2015 Annual Meeting, Mr. Ken Ramsurg (Maryland) advised the Committee that Elizabeth Koncki (Maryland) is the new Safety Liaison for the SWMA. The Committee wishes to thank the people listed below for their contributions.

### **Regional Safety Liaisons:**

#### **Central Weights and Measures Association (CWMA):**

Ms. Julie Quinn, Minnesota Weights and Measures Division

#### **Northeastern Weights and Measures Association (NEWMA):**

Mr. Michael Sikula, New York Bureau of Weights and Measures

#### **Southern Weights and Measures Association (SWMA):**

Ms. Elizabeth Koncki, Maryland Department of Agriculture

#### **Western Weights and Measures Association (WWMA):**

Mr. Brett Gurney, Utah Department of Agriculture and Food

### NCWM Newsletter Safety Article Contributors:

Ms. Julie Quinn (Minnesota): *Making Annual Safety Training Fun, 2014 Issue 2*

Mr. Mike Sikula (New York): *Emergency Preparedness – Gas Stations with Transfer Switches, 2014 Issue 3*

Ms. Elizabeth Koncki (Maryland): *Driving While Towing a Trailer, 2015 Issue 1*

Mr. Brett Gurney (Utah): *Don't Be a Statistic: Watch for Workplace Hazards, 2015 Issue 2*

Mr. Doug Rathbun (Illinois): *Defensive Driving, 2015 Issue 3*

The Committee asks for suggestions for safety articles that people would like to see in future newsletters and/or safety issues that need to be addressed immediately. The Committee reminds regional associations to check the submission deadlines for their upcoming article assignments. E-mail all articles to the NCWM headquarters at [info@ncwm.net](mailto:info@ncwm.net).

Issue	Article Source	Article Deadline
Issue 3: September 2015	CWMA	August 14, 2015
Issue 1: February 2016	NEWMA	January 15, 2016
Issue 2: May 2016	SWMA	April 15, 2016
Issue 3: September 2016	WWMA	August 15, 2016
Issue 1: February 2017	CWMA	February 17, 2017

### Regional Associations Comments:

WWMA encourages weights and measures officials to submit safety reports and issues to their Regional Safety Liaison. The WWMA also commends Mr. Bret Gurney, Western Regional Safety Liaison, for his timely safety article submitted to the NCWM newsletter on “Controlling the Risk of Solitary Workers.”

CWMA 2014 Interim Meeting (Missouri): An incident was reported where a compressed natural gas (CNG) test vessel became a rocket after springing a leak near the valve during gravimetric testing. Missouri also reported an incident where both the diesel and gasoline discharge hoses on their RMTD testing units caught fire because of a short in the pump that caused it to seek ground through the discharge hoses.

CWMA Safety Liaison, Julie Quinn is going to take the incident list generated at the last two meetings and survey the CWMA states on whether they have:

- experienced the hazards identified on the lists (to get a sense of how common they are); and
- addressed these identified hazards through engineering solutions, personal protective equipment, policies, training, or other methods to prevent future injuries incidents.

SWMA heard from Mr. Ken Ramsburg (Maryland) indicating that Ms. Elizabeth Koncki (Maryland) is replacing Dr. Matt Curran (Florida) as the SWMA’s Regional Safety Liaison. The SWMA’s contribution to the newsletter was last due in January 2015; the next contribution is due in April 2016. If members are interested in any specific safety-related topics, please contact Mrs. Koncki.

NEWMA recommends providing safety videos on the NCWM website. An example of a basic safety issue is correct lifting techniques to avoid injury. NEWMA members agree that safety measures increase inspector confidence and demonstrate that management is mindful of individual safety and wellbeing.

### 420-2 I PDC Publication

The Professional Certification Exam Modules and the Body of Knowledge are available to all individuals, whether they are NCWM members or not. These documents may be accessed through the “Professional Certification” tab.

The Model Field Training Program documents are available to all individuals and may be accessed through the “Training” tab. Additional training documents and videos are available under the same tab. Trainers are encouraged to use these documents and to periodically check the website for updates.

Administrative documents describing the Professional Certification Program are only available to members under the “Professional Certification” tab.

Annual 2015 Meeting: The Committee proposed to drop this item from the PDC Agenda. All Committee materials are available electronically from the NCWM website

### Regional Associations Comments:

The WWMA commends NCWM for its work on improving the accessibility to publications on its webpage.



At the SWMA Annual Meeting, Mr. Dale Saunders, PDC Chair, reminded the SWMA that the PDC publications are available for viewing on the NCWM website and encourages members to access them.

---

Ms. Cheryl Ayer, New Hampshire | Committee Chair  
Ms. Angela Godwin, Ventura County, California | Member  
Mr. Stacy Carlsen, Marin County, California | Member  
Ms. Julie Quinn, Minnesota | Member  
Mr. Doug Killingsworth, Georgia | Member  
Mr. Richard Shipman, Rice Lake Weighing Systems | Associate Membership Representative  
Ms. Tina Butcher | NIST Liaison  
Mr. Ross Andersen | Certification Coordinator

**Professional Development Committee**

## Appendix A

### Safety Awareness Presentation

We all share safety program requirements. Most of us don't have the funding for industrial hygienists. Can we pool our resources and experiences so we do not have to reinvent the wheel? We have been sharing incident reports in a sporadic way but can we start cooperating on the other aspects of our programs?

- Identify hazards
  - Through incident reports
  - Through OSHA consultation
  - Through Hazard Assessments (Works well in facilities under your control)
  - Through Field Level Hazard Assessments (Requires field staff to be trained)
    - Can anyone share their FLHA checklists?
- Analyze Hazards
  - OSHA's Focus Four (responsible for 90% of all deaths and injuries)
    - Falls
    - Electrocutation
    - Struck by
    - Crushes/Caught between
  - Risk assessment grids
- Control hazards
  - Eliminate
  - Engineering solutions
  - Personal protective Equipment
  - Policies (Behavior Modification)
- Communicate hazards to Staff (Education)
  - Initial Training
    - ERTK
    - Driver Safety
    - Field Level Hazard Assessments
    - MSHA
    - Respiratory
    - Overhead cranes and hoist inspection

- Fire extinguisher
- Annual Training
  - ERTK
  - MSHA
  - Respiratory

## Report of the National Type Evaluation Program (NTEP) Committee

Mr. John Gaccione, Chairman  
Westchester County, New York

### 500 INTRODUCTION

This is the report of the NTEP Committee (hereinafter referred to as the “Committee”) for the 100<sup>th</sup> Annual Meeting of the National Conference on Weights and Measures (NCWM). This report is based on the Interim Report offered in the NCWM Publication 16, testimony heard at public hearings, comments received from the regional weights and measures associations and other parties, the addendum sheets issued at the Annual Meeting, and actions taken by the membership at the voting session of the Annual Meeting. The informational items presented below were adopted as presented when the Committee’s report was approved.

Table A identifies the agenda items and appendix items. The agenda items in the Report are identified by Reference Key Number, title, page number and the appendices by appendix designations. The acronyms for organizations and technical terms used throughout the agenda are identified in Table C. The first three digits of the Reference Key Numbers of the items are assigned from The Subject Series List. The status of each item contained in the report is designated as one of the following: **(D) Developing Item:** the Committee determined the item has merit; however, the item was returned to the submitter or other designated party for further development before any action can be taken at the national level; **Informational (I) Item:** the item is under consideration by the Committee but not proposed for Voting; **(V) Voting Item:** the Committee is making recommendations requiring a vote by the active members of NCWM; **(W) Withdrawn Item:** the item has been removed from consideration by the Committee.

Table B provides a summary of the results of the voting on the Committee’s items and the report in its entirety. Some Voting Items are considered individually; others may be grouped in a consent calendar. Consent calendar items are Voting Items that the Committee has assembled as a single Voting Item during their deliberation after the Open Hearings on the assumption that the items are without opposition and will not require discussion. The Voting Items that have been grouped into consent calendar items will be listed on the addendum sheets. Prior to adoption of the consent calendar, the Committee entertains any requests from the floor to remove specific items from the consent calendar to be discussed and voted upon individually.

Proposed revisions to the handbook(s) are shown as follows: 1) deleted language is indicated with a **bold face font using strikeouts** (e.g., ~~this report~~), 2) proposed new language is indicated with an **underscored bold faced font** (e.g., new items), and 3) nonretroactive items are identified in *italics*. When used in this report, the term “weight” means “mass.”

**Note:** The policy of NIST is to use metric units of measurement in all of its publications; however, recommendations received by NCWM technical committees and regional weights and measures associations have been printed in this publication as submitted. Therefore, the report may contain references to U.S. customary units.

**Table A  
Table of Contents**

<b>Reference Key</b>	<b>Title of Item</b>	<b>NTEP Page</b>
<b>500</b>	<b>INTRODUCTION</b> .....	<b>1</b>
<b>510</b>	<b>INTERNATIONAL</b> .....	<b>3</b>
510-1	Mutual Recognition Arrangement (MRA) .....	3
510-2	Mutual Acceptance Arrangement (MAA) .....	5
<b>520</b>	<b>ACTIVITY REPORTS</b> .....	<b>5</b>
520-1	NTEP Participating Laboratories and Evaluations Reports.....	5
520-2	NTEP Sector Reports .....	6
<b>530</b>	<b>CONFORMITY ASSESSMENT PROGRAM</b> .....	<b>8</b>
530-1	Conformity Assessment Program .....	8
530-2	Device Categories for VCAP .....	11
<b>550</b>	<b>OTHER ITEMS – DEVELOPING ITEMS</b> .....	<b>13</b>
550-1	NTEP Contingency Plan.....	13

**Appendices**

A	Item 520-1: NTEP Statistics Report .....	A1
B	Item 520-2: Belt-Conveyor Scale Sector Meeting Summary.....	B1
C	Item 520-2: Grain Analyzer Sector Meeting Summary .....	C1
D	Item 520-2: Measuring Sector Meeting Summary.....	D1
E	Item 520-2: Software Sector Meeting Summary .....	E1
F	Item 520-2: Weighing Sector Meeting Summary .....	F1
G	Item 520-2: Multiple Dimension Measuring Devices Work Group Meeting Summary .....	G1

**Table B  
Summary of Voting Results**

<b>Reference Key Number</b>	<b>House of Senate Representatives</b>		<b>House of Delegates</b>		<b>Results</b>
	<i>Yeas</i>	<i>Nays</i>	<i>Yeas</i>	<i>Nays</i>	
To Accept Report	Voice Vote				Adopted

**Table C**  
**Glossary of Acronyms and Terms**

Acronym	Term	Acronym	Term
CC	Certificate of Conformance	NCWM	National Conference on Weights and Measures
CIML	International Committee of Legal Metrology	NIST	National Institute of Standards and Technology
DoMC	Declaration of Mutual Confidence	NTEP	National Type Evaluation Program
IV	Initial Verification	OIML	International Organization of Legal Metrology
MAA	Mutual Acceptance Arrangement	OWM	Office of Weights and Measures
MC	Measurement Canada	R	Recommendation
MDMD	Multiple Dimension Measuring Devices	VCAP	Verification Conformity Assessment Program
MRA	Mutual Recognition Arrangement	WG	Work Group

**Details of All Items**  
*(In order by Reference Key)*

## 510 INTERNATIONAL

### 510-1 Mutual Recognition Arrangement (MRA)

**Background/Discussion:**

The Mutual Recognition Agreement (MRA) between Measurement Canada (MC) and NTEP labs originated April 1, 1994. Since that time, the original MRA has expanded, and a second MRA covering measuring devices was developed. On Tuesday, July 19, 2011, NCWM Chairman Mr. Tyson and MC President Mr. Johnston signed a renewal MRA that combines the weighing and measuring devices into one document and provides for continued cooperation between the two organizations and continuation of the beneficial partnership. The new MRA is effective for five years.

**The scope of the current MRA includes:**

- gasoline and diesel dispensers;
- high-speed dispensers;
- gasoline and diesel meters intended to be used in fuel dispensers and truck refuelers;
- electronic computing and non-computing bench, counter, floor, and platform scales with a capacity up to 1000 kg (2000 lb);
- weighing/load receiving elements with a capacity of up to 1000 kg (2000 lb);
- electronic weight indicating elements (except those that are software based, that is, programmed by downloading parameters); and
- mechanical scales up to 10 000 kg (20 000 lb).

MC, NTEP, and all of our mutual stakeholders agree that the MRA is a benefit for the North American weights and measures industry. The NTEP Committee appreciates the efforts and cooperation of MC.

Mettler-Toledo commented that their company has experienced MRA application issues due to differences in the test weights used for evaluation of high precision Class I and II balances. NTEP will discuss the issues with MC.

During the 2014 Annual Meeting, MC announced their agreement to accept test data recorded by a NTEP evaluator at a manufacturer's facility, as per the NTEP contingency plan, if the test site and test plan were agreed upon prior to testing.

The NTEP Committee continued their discussion with MC to include Multiple Dimension Measuring Devices (MDMD) in the MRA. MC has requested that they be the primary laboratory for MDMD evaluations conducted under the MRA, which has met some resistance due to concerns that it may delay issuance of certificates. Mr. Gilles Vinet suggested that although MC may typically take more time than NTEP to issue a Canadian type approval, NTEP should not have to wait too long for MC data as MC could send data to NTEP shortly after testing is completed. Time spent evaluating the data and issuing the Certificate of Conformity (CC) and Canadian Notice of Approval would then be conducted separately by NTEP and MC. The Committee is strongly considering MC's proposal and is interested in additional input from U.S. manufacturers and the MDMD Work Group (WG) and other affected parties.

A meeting of the MDMD WG was held October 2014 and again in May 2015. During the meetings, U.S. manufacturers expressed concern about MC being identified as the primary laboratory for the evaluation of MDMD devices submitted under the MRA and a request to consider a recommendation that the MC Evaluation Checklist be the primary document for the evaluation of MDMD devices. The WG discussed these two requests as a single item and developed the following position on the item and offers the counter proposal shown below.

With regards to the MDMD position of the addition of the MDMD addition to the United States/Canada MRA, the MDMD WG submits the following decisions from their May 2015 meeting.

The WG consisting of 17 registered participants rejected the recommendation to add MDMD to the MRA as presented by the NCWM Board of Directors and the NTEP Committee. The recommendation consisted of the stipulation that the MC evaluation checklist be the primary evaluation document and that the MC Evaluation Laboratory be designated the primary evaluation laboratory. The decision was based on a show of hands of the 17 participants present. The show of hands was 1 in favor, 12 opposed, and 4 abstained. (Meeting participants consisted of individuals ranging from users, manufacturers, laboratory personnel, and Canadian and United States Officials.)

The justification for the rejection is:

1. Concerns regarding the device evaluation times.
2. Loss of evaluation knowledge and experience in the U.S. laboratory.
3. Concern of a single lab being impacted by budget and/or personnel changes.
4. A single lab is not conducive to the idea of mutual recognition.

The MDMD WG offers the following recommendation and if agreed to will support the addition of MDMD to the MRA provided:

1. Evaluation data from either a NTEP authorized laboratory or MC can be used by both countries in the issuance of their respective certifications.
2. A MC/NTEP evaluation checklist document be created and accepted by both NTEP and MC.
3. A common performance evaluation results document be created and accepted by both NTEP and MC.

During the 2015 Annual Meeting, the NTEP Committee reviewed the issues and discussed the item with MC. Progress was made towards a solution, and the Committee plans to move forward with expansion of the MRA to include MDMD devices with the renewal of the agreement in 2016.

## 510-2 Mutual Acceptance Arrangement (MAA)

### Background/Discussion:

Information regarding the International Organization of Legal Metrology (OIML) MAA can be found at <https://www.oiml.org/>. NCWM has signed the OIML MAA Declaration of Mutual Confidence (DoMC) for Recommendation (R) 60 Load Cells as a utilizing participant. A utilizing participant is a participant that does not issue any OIML Certificate of Conformance (CC) nor OIML Test Reports and/or Test Reports under a DoMC but does utilize the reports issued by issuing participants.

The last meeting of the Committee on Participation Review (CPR) for R 60 and R 76 was hosted by NIST March 18 and 19, 2014, and was attended by Dr. Charles Ehrlich, National Institute of Standards and Technology (NIST), Office of Weights and Measures (OWM); Mr. Barton, NIST, OWM; and Mr. Darrell Flocken, NCWM.

The United States (NTEP) supported the OIML B 10 documents for the MAA with the provision that the use of manufacturer test data was clearly identified on the MAA test report because NTEP cannot use manufacturer test data towards issuance of an NTEP certificate. Consequently, the CIML voted and approved the Amendment to B 10 to allow the inclusion of test data from manufacturers, on a strictly voluntary basis, at its October 2012 meeting in Bucharest, Romania. Dr. Ehrlich gave an update to the Committee during the 2013 Interim Meeting, reviewing the history of the above discussions, deliberations, and CIML votes, confirming that the outcomes aligned with the NTEP Committee's recommendations and the instructions provided by the NCWM Board of Directors.

Dr. Ehrlich requested in January 2013 that NCWM review its MAA policy regarding participation in R 76. The NCWM Board recapped the decision process to participate as a utilizing participant for R 60. Existing policy from 2006 is not to participate in R 76 until NCWM is able to do so as an Issuing Participant. The Board revisited the 2006 discussions leading to that decision, including considerations for NTEP labs' work load, potential lost expertise, concerns with quality of evaluations at some foreign labs, etc. Dr. Ehrlich wanted NCWM to reconsider and, if there was no possibility in sight that the NCWM could become an Issuing Participant, then it should consider becoming a utilizing participant for OIML R 76. Some U.S. manufacturers support NCWM policy, but others would like to have one-stop shopping. The MAA also includes R 49 (water meters) and R 117 (RMFD) may be added soon. Since there are no new developments to effect the decision, the NCWM Board of Directors agree to maintain existing policy at this time.

Dr. Ehrlich again raised the matter of MAA participation to the NTEP Committee in January 2015, indicating that perhaps some things have changed, and requested a study be undertaken by the NTEP Committee to identify the current barriers to NTEP's participation in the MAA as an Issuing Participant for R 76.

From January 2011 to June 2015, forty-two NTEP certificates for load cells were issued under the MAA. The NTEP Administrator reviewed all MAA test data and drafted the CCs.

## 520 ACTIVITY REPORTS

### 520-1 NTEP Participating Laboratories and Evaluations Reports

#### Background/Discussion:

The NTEP weighing and measuring laboratories held a joint meeting March 10 - 12, 2015, in Sacramento, California.

The NTEP measuring laboratories met in October 2014 prior to the NTEP Measuring Sector meeting in Raleigh, North Carolina.



NTEP routinely surveys customers pertaining to NTEP administration and laboratories customer service. The survey is released to active CC holders. The board routinely reviews the results of the survey to form a continuous improvement plan for NTEP. With any survey, the challenge is to develop a document that is concise enough that customers will respond, while also providing a meaningful set of data. To date, the NCWM Board of Directors is finding general approval of NTEP services.

During the 2015 Interim Meeting, Mr. Truex, NTEP Administrator, updated the Committee on NTEP laboratory and administrative activities through December 2014. The Committee reviewed NTEP statistics through December 2014. During the 2015 Annual Meeting, the Committee reviewed statistics through June 2015. The review of statistics shows incoming applications are relatively comparable to normal, and there exist no significant laboratory backlog issues.

The State of Maryland announced that they are resuming their activities as an NTEP measuring laboratory. The States of Oregon and Kansas have expressed their interest to pursue authorization as a NTEP Participating Field Laboratory for large capacity weighing devices. NTEP is working with Oregon and Kansas toward this goal.

## **520-2 NTEP Sector Reports**

### **Background Discussion:**

All NTEP Sector reports were available to members at the time NCWM Publication 15 was published. The NTEP Committee is committed to ensuring that electronic versions of Sector reports are available with NCWM Publication 15. Please note that the Sector reports will only be available in the electronic version of NCWM Publication 15 at <https://www.ncwm.net/meetings/interim/archive>; they will not be available in the printed versions of NCWM Publication 15.

### **NTEP Belt-Conveyor Scale Sector:**

The NTEP Belt-Conveyor Scale Sector met February 20, 2014, in Pittsburgh, Pennsylvania. A final draft of the meeting summary was provided to the Committee prior to the 2015 NCWM Interim Meeting for review and approval. (See Appendix B.)

A meeting of the NTEP Belt-Conveyor Scale Sector was held February 26, 2015, in St. Louis, Missouri. For questions on the current status of Sector work or to propose items for a future meeting, please contact the Sector Technical Advisor:

### **Technical Advisor**

Mr. John Barton  
NIST, OWM  
100 Bureau Drive, MS 2600  
Gaithersburg, MD 20899  
Phone: (301) 975-4002  
Fax: (301) 975-8091  
E-mail: [john.barton@nist.gov](mailto:john.barton@nist.gov)

### **NTEP Grain Moisture Meter and NIR Protein Analyzer Sectors:**

The NTEP Grain Moisture Meter and NIR Protein Analyzer Sectors held a joint meeting in Kansas City, Missouri, August 20 - 21, 2014. A draft of the final summary was provided to the Committee prior to the 2015 NCWM Interim Meeting for review and approval. (See Appendix C.)

It was decided that the NTEP Grain Analyzer (Georgia) Sector will not conduct a meeting in 2015. Neither a face-to-face or web meeting as announced. The decision was made primarily due to a lack of agenda items. Most of the tentative agenda items were updates and reports and the two S&T Committee items (Item 310-1, G-S.1. Identification from the Software Sector and 360-4, Appendix D – Definitions: Remote Configuration Capability) are still developing items. Therefore, Sector Chair Karl Cunningham decided to provide a Grain Analyzer Sector Report of Updates instead of holding a web meeting. A report of updates will be compiled and circulated to all Sector members. A comment sheet for feedback will also be circulated and summary of comments reported back to the members.

For questions on the current status of Sector work or to propose items for a future meeting, please contact the Technical Advisor:

**Technical Advisor**

Ms. G. Diane Lee  
NIST, OWM  
100 Bureau Drive, MS 2600  
Gaithersburg, MD 20707  
Phone: (301) 975-4005  
Fax: (301) 975-8091  
E-mail: [diane.lee@nist.gov](mailto:diane.lee@nist.gov)

**NTEP Measuring Sector:**

The NTEP Measuring Sector met October 3 - 4, 2014, in Raleigh, North Carolina. A draft of the final summary was provided to the Committee prior to the 2015 NCWM Interim Meeting for review and approval. (See Appendix D.)

The next meeting of the NTEP Measuring Sector Meeting is scheduled for September 15 - 16, 2015, in Denver, Colorado. The second day of the meeting will be a joint meeting of the NTEP Measuring and Software Sectors. For questions on the current status of Sector work or to propose items for a future meeting, please contact the Sector Technical Advisor:

**Technical Advisor**

Mr. Clark Cooney  
NIST, OWM  
100 Bureau Drive, MS 2600  
Gaithersburg, MD 20899  
Phone: (301) 975-4615  
Fax: (301) 975-8091  
E-mail: [clark.cooney@nist.gov](mailto:clark.cooney@nist.gov)

**NTEP Software Sector:**

The NTEP Software Sector met August 27 - 28, 2014, in Atlanta, Georgia. A final draft of the meeting summary was provided to the Committee prior to the 2015 NCWM Interim Meeting for review and approval. (See Appendix E.)

The next meeting of the NTEP Software Sector is scheduled for September 16 - 17, 2015, in Denver, Colorado. The first day of the meeting will be a joint meeting of the NTEP Measuring and Software Sectors. For questions on the current status of Sector work or to propose items for a future meeting, please contact the Sector Chair and/or the NTEP Administrator:

**Chair**

Mr. James Pettinato  
FMC Technologies Measurement Solutions, Inc.  
1602 Wagner Avenue  
Erie, PA 16510  
Phone: (814) 898-5250  
Fax: (814) 899-3414  
E-mail: [jim.pettinato@fmcti.com](mailto:jim.pettinato@fmcti.com)

**NTEP Administrator**

Mr. Jim Truex  
NCWM  
1135 M Street, Suite 110  
Lincoln, NE 68508  
Phone: (740) 919-4350  
Fax: (740) 919-4348  
E-mail: [jim.truex@ncwm.net](mailto:jim.truex@ncwm.net)

**NTEP Weighing Sector:**

The NTEP Weighing Sector met August 26 - 27, 2014, in Atlanta, Georgia. A final draft of the meeting summary was provided to the Committee prior to the 2015 NCWM Interim Meeting for review and approval. (See Appendix F.)

The next NTEP Weighing Sector meeting is scheduled for August 25 - 26, 2015, in Denver, Colorado. For questions on the current status of Sector work or to propose items for a future meeting, please contact the Sector Technical Advisor:

**Technical Advisor**

Mr. Rick Harshman  
NIST, OWM  
100 Bureau Drive, MS 2600  
Gaithersburg, MD 20899  
Phone: (301) 975-8107  
Fax: (301) 975-8091  
E-mail: [richard.harshman@nist.gov](mailto:richard.harshman@nist.gov).

**NTEP Multiple Dimension Measuring Devices (MDMD) Work Group:**

The NTEP MDMD WG met October 28 - 29, 2014, in Reynoldsburg, Ohio. A final draft of the meeting summary was provided to the Committee prior to the 2015 NCWM Interim Meeting for review and approval. (See Appendix G.) The NTEP Committee reviewed and approved all 2014 NTEP Sector and Work Group reports during the Interim Meeting.

The NTEP MDMD WG met again May 12 - 13, 2015, and has scheduled another meeting for September 22 - 23, 2015, in Reynoldsburg, Ohio. For questions on the current status of WG or to propose items for a future meeting, please contact WG Chair, Mr. Robert Kennington at [rkennington@cubiscan.com](mailto:rkennington@cubiscan.com) or NTEP Specialist, Mr. Darrell Flocken at [darrell.flocken@ncwm.net](mailto:darrell.flocken@ncwm.net).

## **530 CONFORMITY ASSESSMENT PROGRAM**

### **530-1 Conformity Assessment Program**

**Background/Discussion:**

The Conformity Assessment Program was established to ensure devices produced after the device has been type evaluated and certified by NTEP continue to meet the same requirements. This program has three major elements: 1) Certificate Review (administrative); 2) Initial Verification (inspection and performance testing); and 3) Verified Conformity Assessment (influence factors). This item is included on the Committee's agenda to provide an update on these elements.

**Certificate Review:**

Certificates are constantly under review by NTEP staff and laboratories. Many active certificates are amended annually because of manufacturer submission for evaluation or issues reported by the states pertaining to information on the certificate. When the devices are re-evaluated and certificates are amended, all information is reviewed and necessary steps are taken to assure compliance and accurate, thorough information is reported on the certificate.

In an effort to keep certificate information up to date, the Committee continues to offer an opportunity for active certificate holders to update contact information contained in the "Submitted By" box on certificates. This is offered during the payment period of their annual maintenance fee. Many CC holders have taken advantage of the opportunity for hundreds of NTEP certificates.

**Initial Verification (IV):**

The IV initiative is ongoing. Field enforcement officials perform an initial inspection and test on new installations on a routine basis. The Committee recognized that the states do not want IV reporting to be cumbersome.

An IV report form was developed several years ago. The Committee desired a simple form, perhaps web-based for use by state and local regulators. The form was approved by the Committee and distributed to the states. A completed form can be submitted via mail, e-mail, fax, or online. The form is available to regulatory officials who are members of NCWM at [www.ncwm.net/ntep/conformity/verification](http://www.ncwm.net/ntep/conformity/verification).

During the 2014 Annual Meeting, NTEP acknowledged that the regulators have not bought into the IV report form. Industry representatives stated that IV is very important to ensure conformity assessment, and the NCWM should push harder for reporting non-compliance issues found during IV.

**VCAP:**

NCWM has been concerned about production meeting type and protecting the integrity of the NTEP CC since the inception of NTEP. The Board has consistently reconfirmed its belief that conformity assessment is vital to NTEP's continued success.

Load cells traceable to NTEP certificates were selected for the initial assessment effort. The NCWM elected to require a systems audit checklist that is to be completed by an outside auditor and submitted to NCWM per Section 221.3.3.3.5 of the VCAP requirements. A VCAP Systems Audit Checklist for Manufacturers and a VCAP Systems Audit Checklist for Private Label Certificate Holders have been developed and are available on the website at [www.ncwm.net/ntep/conformity/vcap/checklists-faqs](http://www.ncwm.net/ntep/conformity/vcap/checklists-faqs). Additionally, the Committee developed a new NCWM Publication 14, administrative policy to distinguish between the requirements for parent NTEP certificate holders (21.3.3.2) and private label certificate holders. The requirements in 21.3.3.7 track the private label checklist requirements: traceability to parent NTEP CC, traceability of the private label cell to a VCAP audit, purchase and sales records, plan to report non-conforming product and non-conforming product in stock, plan to conduct internal audits to verify non-compliance action, and internal audit records.

As a result of VCAP activities, 27 load cell certificates, involving 15 different certificate holders, were changed to "inactive" status.

In 2012 the Committee announced the next device category to be weighing/load receiving elements, 2000 lb capacity and less, using load cells that are not traceable to their own NTEP certificate. As a result of VCAP, 15 certificates, involving 11 different certificate holders, were changed to "inactive" status.

The Committee had discussions about the required number of audits for facilities that manufacture multiple device types. For example, if a company had successful audits for two device types, they might submit a request for a delay from audit requirements for remaining device types, stating that they are all subjected to the same processes and will be audited in the next cycle. The Committee agreed to the request in principal and directed the NTEP Administrator to develop NCWM policy language for consideration during the next Board meeting. As a result, the following policy was adopted by the NCWM Board in October 2013.

**Adding Device Categories to VCAP:  
Policy:**

1. When a new device category is added to the VCAP requirement, NTEP will recognize the current VCAP audit certification in effect, submitted by a certificate holder, for the same certificate holder and same production facility(s), to cover the new device category, continue the manufacturing process for devices covered by NTEP certificates in the newly added device category, until the due date of the next VCAP audit.

**Example:** If a company had successful audits for two device types, they might submit a request for exemption from audit requirements for remaining device types, stating they are all subjected to the same quality management system and will be included in the next audit cycle. The next VCAP audit must be done within three years of the last audit and address all applicable device types produced within that facility.

Seven weighing device categories subject to influence factors, as defined in NIST Handbook 44, "Specifications, Tolerances, and Other Technical Requirements for Weighing and Measuring Devices," were identified and are subject to VCAP audits. The VCAP process requirement is ongoing for load cells and weighing elements that use non-NTEP load cells. Certificate holders for these device types are encouraged to take note that the NTEP Committee and NCWM Board is seriously considering the application of the VCAP requirement to all five remaining categories in the very near future. If and when the VCAP requirements are applied, the certificate holder would be required to have an on-site audit of the manufacturer's quality system and an on-site random and/or review of a production device by an outside auditor to verify compliance with VCAP. Certificate holders are encouraged to research the VCAP requirements on the NCWM website under the NTEP, Conformity Assessment section. Certificate holders are encouraged to review the VCAP requirements applicable to their devices and report concerns to the NTEP Committee.

An NTEP Committee proposal to expand VCAP was advertised prior to the Annual Meeting, on the NCWM website, and during this Annual Meeting. The Committee decided during the 2014 Annual Meeting to include indicating elements at this time and approved the developed timeline below. Certificate holders should take notice that the other categories will be considered and may be added in the very near future.

The following disclaimer has been advertised and communicated by NCWM, “NCWM is working to identify all active certificates subject to VCAP compliance. As a courtesy, affected certificate holders are being notified of VCAP requirements and the established time line. Please note that the NCWM Board of Directors does not consider it to be NCWM's responsibility to notify all certificate holders about affected certificates. Certificate holders are responsible for reviewing their active NTEP certificates and compliance with VCAP.”

NCWM/NTEP VCAP Compliance Timeline Indicating Elements					
Jan. 2015– March 2015	Jan. 2015- May 2016	Jan. 2015- Nov. 2016	Jan. 2015- Dec. 2016	June 2016	Dec. 2016
NTEP notifies active CC holders of VCAP requirements	Parent CC holders to put VCAP QM system in place	Private Label CC holders to put VCAP QM system in place	NTEP evaluates incoming audit reports	NCWM declares CCs inactive if Parent CC holder fails to comply with VCAP	NCWM declares CCs inactive if Private Label CC holder fails to comply with VCAP
	CC holder to have audit conducted by Certified Body	CC holder to have audit conducted by Certified Body	NTEP contacts CC holders not meeting VCAP requirements to encourage compliance		
	Submit audit report to NCWM/NTEP	Submit audit report to NCWM/NTEP			

The Committee has received letters, questions, and many other inquiries pertaining to VCAP. The Committee has worked diligently to answer the questions submitted in a very timely manner, and it knows additional questions will be posed as VCAP progresses. Certificate holders and other interested parties are encouraged to submit written questions to the NTEP Committee. The Committee is pleased to report that it has been successful in answering all the questions to date. Clerical changes have been made to affected VCAP documents as deemed necessary.

During the 2015 Interim and Annual Meetings, the Committee heard no comments about expanding VCAP. The Committee stated their intent to include the remaining categories in the near future. The Committee is seriously considering developing a timeline next year for the remaining categories, which includes: automatic weighing systems, belt-conveyor scales, and automatic bulk weighing systems. Comments from affected parties are welcomed and appreciated.

During the 2015 NCWM Annual Meeting, the Committee informed membership that it plans to offer a recommended amendment to NTEP administrative policy in NCWM Publication 15 for 2016. NTEP has learned that the two organizations (ANSI-ASQ National Accreditation Board [ANAB] and International Laboratory Accreditation Cooperation [ILAC]) have a mutual recognition agreement. Researching this fact, NTEP contacted a U.S. Certification Body that is accredited by ANAB and a non-U.S. Certification Body accredited by ILAC and asked them if they would accept an audit report from the other Certification Body. Both responded they would provide the Certification Body was accredited by a Signatory of the ILAC Mutual Recognition Arrangement and the ISO/IEC 17025 standard is mentioned in the accreditation bodies recognized scope.

Considering the above information and from what NTEP has read on both the ANAB and ILAC web sites, we feel there is sufficient justification to accept the work of ILAC accredited auditing firms that are recognized to the ISO/IEC 17025 standard for testing.

This publication is available free of charge from: <https://doi.org/10.6028/NIST.SP.1210>

As VCAP expanded to include additional devices and more international manufacturers, it became evident the limitation of requiring the Certification Body to be accredited by a U.S. based Accreditation Board created a limited pool of Certification Bodies and Auditor to pick from. In addition, NTEP was approached by a few non-U.S. based Certification Bodies requesting NTEP recognize accreditation organizations such as the ILAC. To address this limitation, the following change is proposed to the accreditation requirements.

- 21.1.3.3.1. The selected Certification Body is to be accredited by ANSI-ASQ National Accreditation Board (ANAB) or by a Signatory of the International Laboratory Accreditation Cooperation (ILAC) Mutual Recognition. The ANSI, ANAB and ILAC are ASQ National Accreditation Board is the U.S. accreditation ~~body~~ bodies for management systems. ANAB and ILAC accredits certification bodies (CBs) for ISO 9001 quality management systems (QMS), ISO 17025 laboratory testing facilities and ISO 14001 environmental management systems (EMS), as well as a number of industry-specific requirements, ~~or equivalent.~~

## 530-2 Device Categories for VCAP

**Source:** NTEP Committee

### **Item under Consideration:**

NCWM must decide if all weighing and load receiving elements should be included in the list of devices that must meet the VCAP requirement or just weighing and load receiving elements with non-NTEP load cells. NTEP has always subjected separate weighing and load-receiving elements to influence factor testing per technical policy. However, NTEP Administrative Policy only lists weighing and load receiving elements using non-NTEP load cells. The Committee will continue to take comments pertaining to the weighing elements conflict and requests input from the NTEP Weighing Sector and other stakeholders.

### **Background/Discussion:**

An NTEP Committee proposal to expand VCAP was advertised prior to the annual meeting, on the NCWM website and during this annual meeting via a handout. The Committee was strongly considering inclusion into the VCAP of Electronic Weighing Instruments and Main Elements with capacities  $\leq 2000$  lb of the following Device Types:

- Complete Scales\*;
- Indicating Elements;
- Automatic Weighing Systems;
- Weighing/Load Receiving Elements;
- Belt-Conveyor Scales; and
- Automatic Bulk Weighing Systems.

This includes both manufacturers and private label holders of Certificates of Conformance (CC) for these device types.

\*It is NTEP's interpretation that the category of complete scales includes types such as but not limited to – Computing, Non-computing Point of Sale, Crane, Monorail, Hopper, and Grain Test Scales.

During the 2014 Annual Meeting, the Committee heard objections from several companies to expanding VCAP to all the device types. The Committee also heard objections to weighing/load receiving elements being included on the list of device types. It became obvious to the Committee that there is a difference in interpretation stemming from the conflicting list of device types in NCWM Publication 14 Administrative Policy (specifying weighing/load receiving elements using non-NTEP load cells) versus the list of devices to be tested for influence factors in NCWM Publication 14, DES, Technical Policy (specifying weighing/load receiving elements). During the Annual Meeting, the NTEP Committee made the decision to pull back on their proposal to include all remaining device categories under VCAP, only adding a timeline for indicating elements of the ongoing load cell and weighing elements using non-

NTEP load cells categories. A primary issue was whether to include all weighing elements or not. NCWM Publication 14, Administrative Policy, Section 21.1.3.1 and NCWM Publication 14, Weighing Devices, Technical Policy Section B.1. appear to contradict each other (see below).

**NCWM Publication 14, Administrative Policy states:**

**21.1.3.1 Devices that Must Meet this Requirement Are Limited to the List Below:**

- Load Cell (T.N.8.)
- Indicating Elements (T.N.8.)
- Weighing/Load Receiving Elements with non-NTEP Load Cells (T.N.8.)
- Complete Scales (T.N.8.)
- Automatic Weighing Systems (T.7.)
- Belt-Conveyor Scales (T.3)
- Automatic Bulk Weighing Systems (T.7.)

**NCWM Publication 14, Weighing Devices, Digital Electronic Scales, Technical Policy states:**

**B.1. Influence Factors Requirements**

Although NIST Handbook 44 contains a set of influence factors requirements, not all devices must be tested for all of the influence factors. The following table identifies the influence factor tests to be conducted on various devices. The main elements and components (indicating elements and load cells) of scales with a capacity greater than 2000 lb must be tested separately for compliance with the influence factors requirements.

**Devices to Be Tested for Influence Factors**

Device Type	Temperature Accuracy <sup>7</sup>	Temperature Zero Drifts	Barometric Pressure	Warm-up Time	Voltage <sup>4</sup>	Power Interruption <sup>5</sup>	Time Dependence
Scales ≤ 2000 lb	X	X	X <sup>1</sup>	X	X	X	X
Scales ≥ 2000 lb	X <sup>2</sup>	X <sup>2</sup>	X <sup>2</sup>	X	X	X	X <sup>2</sup>
ECR's Computers, Bulk-weigher Controllers (without A/D)						X	
Printers						X	
Dials (spring)	X	X					X
Leaver/beam Scales and Pendulum Dials							

This publication is available free of charge from: <https://doi.org/10.6028/NIST.SP.1210>

Device Type	Temperature Accuracy <sup>7</sup>	Temperature Zero Drifts	Barometric Pressure	Warm-up Time	Voltage <sup>4</sup>	Power Interruption <sup>5</sup>	Time Dependence
Weighing/Load-Receiving Elements	X	X	X <sup>1</sup>				X
Indicating Element <sup>6</sup>	X	X		X	X	X	
Class II Scales	X	X		X <sup>3</sup>	X	X	X
<b>Load Cells</b>							
Canister-Type	X	X	X <sup>1</sup>				X
Hydraulic	X	X					X
All Others	X	X					X
<sup>1</sup> Testing is limited to some canister load cells. <sup>2</sup> Compliance with influence factors requirements will be determined according to existing NTEP policy. <sup>3</sup> Test limited to power switch only, not to initial plug-in of the device. <sup>4</sup> Voltage test is 130 and 100 VAC and low battery test on DC. <i>See Section K.60.</i> <sup>5</sup> Power interruption is pulling the plug for 10 seconds. <i>See Section K.19.</i> <sup>6</sup> Indicating elements processing only digital information do not have to be tested for compliance with the influence factors. <sup>7</sup> Compliance with temperature requirements by NTEP is limited to temperatures that are no lower than - 10 °C and no higher than 40 °C.							

During the 2015 Interim and Annual Meetings, the Committee heard testimony opposing inclusion of weighing/load-receiving elements using load cells traceable to an NTEP certificate. The Committee received letters from Cardinal Scale, Fairbanks Scales, and Rice Lake Weighing Systems are opposing the inclusion of all weighing/load-receiving elements primarily because such inclusion would be redundant resulting in the unnecessary expense of additional VCAP testing. The SMA is also on record opposing the inclusion.

The NCWM Board has agreed not to include weighing/load receiving elements using NTEP load cells in the list of device categories subject to VCAP. However, the Board would like certificate holders to take notice that they have the intention of amending the table of devices subject to influence factor testing found in the Weighing Devices Section of NCWM Publication 14.

## 550 OTHER ITEMS – DEVELOPING ITEMS

### 550-1 NTEP Contingency Plan

**Source:**  
NTEP Committee

**Purpose:**  
NTEP Contingency Plan was created to keep NTEP operating and to ensure NTEP services are available at an adequate level including an appropriate number of laboratories and personnel (evaluators) to maintain viable support for NTEP services, including MRAs, MAAs, and potentially to be an R 76 Issuing Participant.



**Item under Consideration:**

The NTEP Committee discussed contingency planning for continuity of NTEP operations. Economic issues have caused NTEP-authorized labs to discontinue services due to government budget cuts in the past. How would NTEP maintain workflow? Are there additional states interested in applying to become an NTEP field lab or an NTEP brick-and-mortar lab? With the recent 2014 hire of an NTEP Specialist, the State of Maryland resuming evaluation of measuring devices, and the interest of states to become NTEP authorized participating laboratories helps with contingency concerns. The Committee continues to discuss these issues during long-range planning sessions and welcomes comments from the membership.

**Background/Discussion:**

The Committee continues to consider whether NCWM should:

1. have additional evaluators under contract to conduct testing at manufacturers' facilities and assist state NTEP laboratories;
2. have an NCWM brick and mortar NTEP laboratory and NTEP evaluators;
3. use a private third party laboratory to conduct NTEP evaluations; and
4. have the OIML MAA Participation as an issuing or utilizing participant.

The Committee has heard testimony expressing support and concerns pertaining to the options. Several stated the Committee should consider adding OIML MAA participation as a Utilizing Participant to the list. Others have urged the Committee to continue working on the idea of NCWM NTEP evaluators, an NCWM NTEP lab, and keeping all options open. One member asked the Committee to consider accepting manufacturer compliance data in lieu of hiring NTEP contractors. Another suggestion from the floor was to consider strengthening and utilizing IV as part of the NTEP process. A representative of a state brick and mortar NTEP laboratory asked the Committee to move cautiously forward and not destroy the state NTEP labs. He expressed concern that the establishment of an NCWM NTEP brick and mortar lab could lead to significant legal complications for the states.

The Committee continues to reiterate to the membership that, at this time, the preferred course of action would be the option of evaluators under contract or use NCWM NTEP staff to assist the laboratories. The Committee recognizes the commitment the states with NTEP laboratories have made over the years and would only resort to contingency measures in the event of a severe loss of state lab resources. Labs are handling the current demands without a need for contingency measures. The Committee is updated on the status of the participating laboratories, personnel, and backlog on a quarterly basis and will continue to keep NTEP contingency a priority.

---

Mr. John Gaccione, Westchester County, New York | Committee Chair  
Mr. Ron Hayes, Missouri | NCWM Chairman  
Mr. Jerry Buendel, Washington State | NCWM Chairman-Elect  
Mr. James Cassidy, City of Cambridge, Massachusetts | Member  
Mr. Kenneth Ramsburg, Maryland | Member  
Mr. Jim Truex, NCWM | NTEP Administrator

**National Type Evaluation Program Committee**

## Appendix A NTEP Statistics Report

<b>General NTEP Statistics</b>	<b>Last Year</b>	<b>This Year to Date</b>
	<b>10/01/13 – 9/30/14</b>	<b>10/01/14 – 6/30/15</b>
Total Applications Processed	(34) 311	(36) 208
Applications Completed	289	231
New Certificates Issued	268	208
Active NTEP Certificates		1951
		( ) = Reactivations
<b>Assignments to Labs per Year</b>	<b>10/1/13 – 9/30/14</b>	<b>10/1/14 – 6/30/15</b>
California	39	14
Canada	(1) 5	3
GIPSA-DC	0	0
GIPSA-KC	8	6
Maryland	(3) 42	(9) 42
New York	9	(5) 8
NIST Force Group	4	3
North Carolina	(1) 26	11
Ohio	56	35
Oregon	0	(1) 1
NTEP Field	2	4
NTEP Administrator	(1) 123	86
Applications Not Yet Assigned to a Lab		0
		( ) = Reassignments from another lab
<b>Process Statistics</b>	<b>10/2008 - Present</b>	<b>10/2000 – 9/2008</b>
Average Time to Assign an Evaluation	4.7 Days	11.8 Days
Average Time to Complete an Evaluation	87.2	169.7 Days

This publication is available free of charge from: <https://doi.org/10.6028/NIST.SP.1210>

**Report on Evaluations in Progress**

<b>Evaluations in Progress</b>	<b>0-3 Months</b>	<b>3-6 Months</b>	<b>6-9 Months</b>	<b>9-12 Months</b>	<b>Over 1 Year</b>	<b>Total</b>
September 30, 2011	42	28	11	5	19	105
December 31, 2011	37	19	23	5	17	101
March 31, 2012	40	17	7	21	14	99
June 30, 2012	41	21	10	6	20	98
September 30, 2012	50	30	15	7	19	121
December 31, 2012	32	24	17	7	18	98
March 31, 2012	36	12	14	12	18	92
June 30, 2013	53	18	6	6	19	102
September 30, 2013	44	32	5	4	21	106
December 31, 2013	41	25	24	2	24	116
March 31, 2014	53	23	13	17	11	117
June 30, 2014	55	30	14	8	19	126
September 30, 2014	44	38	18	6	19	125
December 31, 2014	44	17	17	12	16	106
March 31, 2015	43	24	10	13	17	107
<b>June 30, 2015</b>	<b>39</b>	<b>21</b>	<b>12</b>	<b>5</b>	<b>15</b>	<b>92</b>

<b>In Progress by Lab</b>	<b>0-3 Months</b>	<b>3-6 Months</b>	<b>6-9 Months</b>	<b>9-12 Months</b>	<b>Over 1 Year</b>	<b>Total</b>
California	2	4	3	2	1	12
Canada	2	1	0	1	0	4
GIPSA-DC	0	0	0	0	0	0
GIPSA-KC	4	2	0	0	2	8
Maryland	11	5	6	0	4	26
New York	1	0	1	0	0	2
NIST Force Group	0	0	0	0	4	4
North Carolina	6	2	1	1	1	11
Ohio	9	5	1	1	2	18
Oregon	0	0	0	0	1	1
NTEP Staff	4	2	0	0	0	6
Unassigned	0	0	0	0	0	0
<b>Total Pending:</b>						<u><u>92</u></u>

This publication is available free of charge from: <https://doi.org/10.6028/NIST.SP.1210>

**10-Year Report on Applications Received by Quarter**

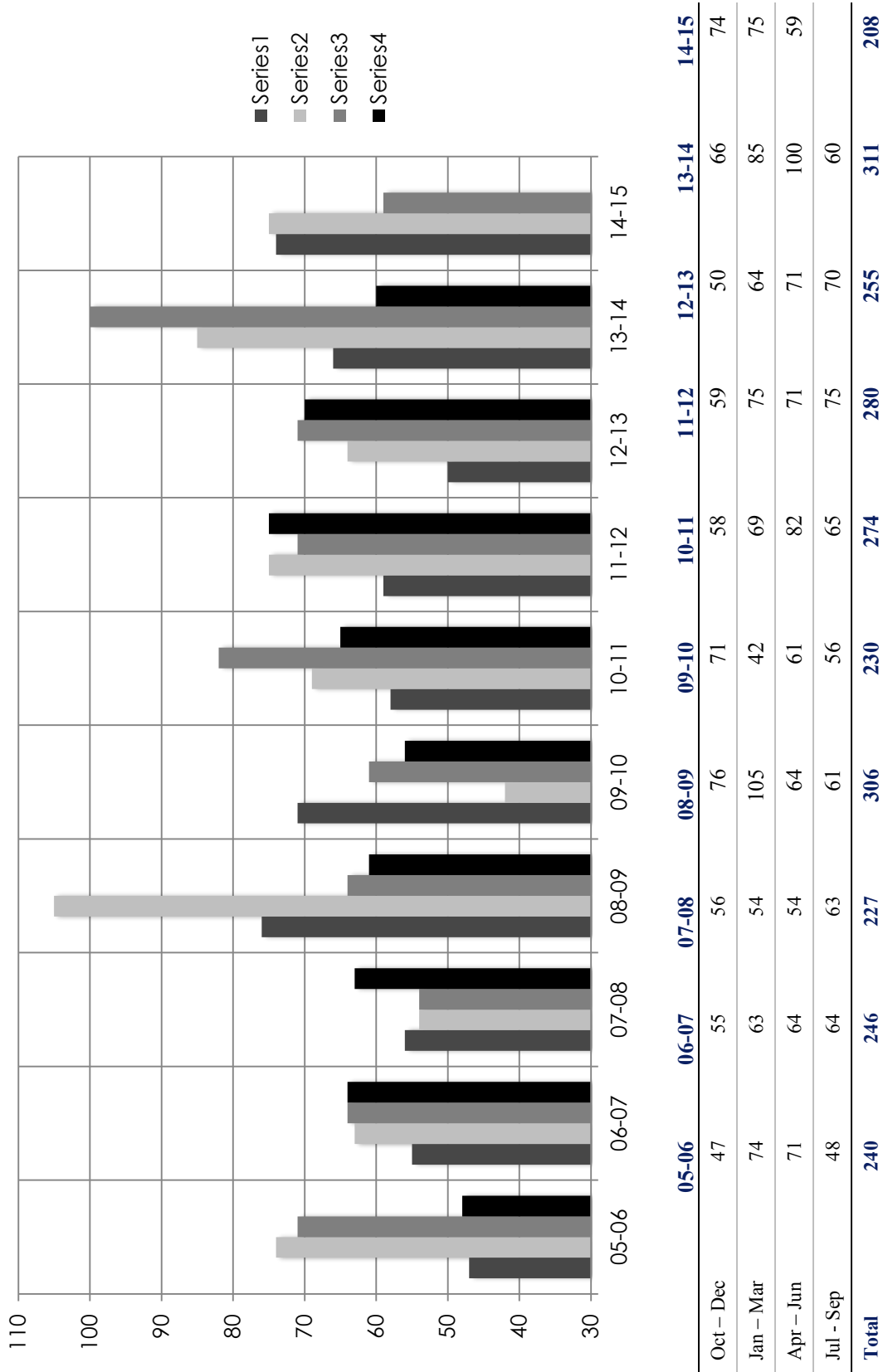

THIS PAGE INTENTIONALLY LEFT BLANK

## Appendix B

# National Type Evaluation Program (NTEP) Belt-Conveyor Scale (BCS) Sector Meeting Summary

February 20, 2014  
Pittsburgh, Pennsylvania

## INTRODUCTION

The charge of the BCS Sector is important in providing appropriate type evaluation criteria based NIST Handbook 44, “Specifications, Tolerances, and Other Technical Requirements for Weighing and Measuring Devices,” Sections 1.10. General Code and 2.21. BCS Systems. The Sector’s recommendations are presented to the National Type Evaluation Program (NTEP) Committee each January for approval and inclusion in NCWM Publication 14, “Technical Policy, Checklists and Test Procedures” for National Type Evaluation.

The Sector is also called upon occasionally for technical expertise in addressing difficult NIST Handbook 44 issues on the agenda of National Conference on Weights and Measures (NCWM) Specifications and Tolerances (S&T) Committee. Sector membership includes industry, NTEP laboratory representatives, technical advisors, and the NTEP Administrator. Meetings are held annually, or as needed and are open to all NCWM members and other registered parties.

Proposed revisions to the handbooks/publications are shown as follows: 1) deleted language is indicated with a **bold face font using strikeouts** (e.g., ~~this report~~), 2) proposed new language is indicated with an **underscored bold faced font** (e.g., new items), and 3) nonretroactive items are identified in *italics*. There are instances where the Sector will use **red** text and/or **highlighted** text to bring emphasis to text that requires additional attention. When used in this report, the term “weight” means “mass.”

**Note:** It is the policy of the National Institute of Standards and Technology (NIST) to use metric units of measurement in all of its publications; however, recommendations received by NCWM technical committees and regional weights and measures associations have been printed in this publication as submitted. Therefore, the report may contain references in U.S. customary units.

---

**Table A**  
**Table of Contents**

---

<b>Title of Content</b>	<b>Page NTEP B</b>
<b>I. Carry-over Items</b> .....	<b>3</b>
A. Belt-Conveyor Scale NTEP Checklist .....	3
B. Linearization Feature for BCS: .....	4
C. Conveyor Belt Profiling: .....	6
D. Field Test Procedures for Reference Scales .....	7
<b>II. New items</b> .....	<b>8</b>
A. 2014 NIST Handbook 44 Changes .....	8
1) Appendix C – Units of Mass (ton) .....	9
2) Deletion of/minimum required maximum conveyor lengths .....	13

B. Proposals recommended by the NTEP Software Sector..... 14

    1) Identification of Certified Software..... 14

    2) Software Protection/Security ..... 15

    3) Software Maintenance and Reconfiguration..... 19

C. Review of NCWM Publication 14 List of Sealable Parameters for BCS Systems ..... 22

**III. Attendance ..... 24**

Attachment A ..... 25

    A. Models to be Submitted for Evaluation ..... 25

    B. Certificate of Conformance Parameters ..... 25

    C. Replacement Parts ..... 26

    D. Substitution of the Master Weight Totalizer ..... 26

    E. Checklist and Test Procedures ..... 26

**Table B**  
**Glossary of Acronyms and Terms**

Acronym	Term	Acronym	Term
BCS	Belt-Conveyor Scale	NTETC	National Type Evaluation Technical Committee
MTL	Minimum Test Load	OWM	Office of Weights and Measures
NCWM	National Conference on Weights and Measures	MWT	Master Weight Totalizers
NIST	National Institute of Standards and Technology	USNWG	U.S. National Work Group
NTEP	National Type Evaluation Program		

---

**Details of All Items**  
*(In order by Reference)*

---

**I. Carry-over Items**

**A. Belt-Conveyor Scale NTEP Checklist**

**Source:**

USNWG on Belt-Conveyor Scales

**Proposal:**

Amend NCWM Publication 14, *Belt-Conveyor Scales* by incorporating recommended changes that primarily were intended to allow for the evaluation of master weight totalizers (MWT) as a component of a belt-conveyor scale system. This was intended to facilitate the certification of MWTs as replacement instruments and would not necessarily include testing on the entire belt-conveyor scale system.

**Background:**

Prior to the 2009 BCS Sector meeting, Mr. Bill Ripka, Chair submitted a draft of an amended NCWM Publication 14, “Belt-Conveyor Scales Technical Policy, Checklists, and Test Procedures” to the Sector members for review. The proposed changes in this draft related primarily to MWTs intended to be installed as substitutions within a BCS system in addition to a number of other minor editorial changes. Among the recommended changes included in this draft were changes involving procedures used when evaluating semi-automatic and automatic zero-setting mechanisms.

This proposed draft has been offered to be used on a trial basis by NTEP labs when evaluating manufacturer’s replacement instruments (Master Weight Totalizers) that are scheduled to undergo NTEP evaluation. Some device manufacturers within the Sector have indicated that they may have instruments ready to be submitted to NTEP for evaluation.

The NTEP program has been provided with the draft of proposed changes to NCWM Publication 14, “Belt-Conveyor Scales Technical Policy, Checklists, and Test Procedures,” and the NTEP laboratories have agreed to use the amended checklist in order to identify gaps or necessary changes within the draft. Feedback from evaluators who have used this amended checklist is needed so that Sector members are able to determine the need for further development of the proposed changes.

During the 2012 NTEP Belt-Conveyor Scale Sector meeting, the members agreed to request that a report be provided to the Sector by NTEP evaluator(s) that have used the draft of proposed changes that would detail any gaps in the draft and recommend further amendments if necessary. Any input and additional comments from NTEP evaluators that are available will be discussed.

**Discussion/Conclusion:**

At the 2014 BCS Sector meeting, it was reported by the NTEP officials there has not been any devices submitted for type approval that could appropriately be evaluated using the proposed amended checklist. The NIST Technical Advisor accepted the task of reviewing the draft for an amended checklist to ensure that any references to requirements in NIST Handbook 44 were current with the most recent edition of that publication. This review is to be completed by April 30, 2014, and any updates that are necessary will be forwarded to the NTEP Administrator for distribution to the NTEP labs.

Since there have been no applications for type approval of devices that would serve as candidates for a trial of the proposed amended checklist, the Sector had no further comment on this issue.



**NIST Technical Advisor's note:**

Following the February 2014 Sector meeting, the NTEP Belt-Conveyor Scale Sector members were contacted by the Sector Chair, Mr. Bill Ripka, and were asked to participate in teleconference scheduled for June 16, 2014. This teleconference was arranged for the Sector to deliberate on possible further changes to the proposed amendments of NCWM Publication 14," as stated above in this item. The Sector was asked to consider additional changes to the proposal that were intended to expedite the evaluation of MWT installed as a retrofit or substitute instrument within an existing BCS system.

The primary focus of this teleconference was for the members to consider a change that would eliminate a required field permanence test as part of a type evaluation for a MWT being placed into service as a replacement device. These changes would not eliminate any type of testing performed under laboratory conditions but would remove the requirement for a field permanence test once the substitute instrument had been installed in a previously evaluated conveyor system.

The Sector agreed a permanence test is needed for the proper evaluation of an entire belt-conveyor scale system; when installed, however, the suggested revision of this proposal is based on the notion a permanence test is not warranted for a MWT that is installed as an upgrade or replacement instrument for an existing system.

Following the teleconference and follow-up e-mail exchanges among the Sector members, the Sector was asked to respond via a ballot which would indicate whether or not this revision to the original proposal was supported.

The balloting was conducted through e-mail where the results indicated that all active members of the Sector supported these latest recommended changes. The Sector agreed that in addition to the removal of a required permanence testing during a type evaluation for a MWT, several minor editorial changes were also approved. The Sector Chair agreed to forward the revised proposal to the NTEP Administrator for NTEP Committee consideration for Publication 14. The proposed addition is included in Attachment A.

**B. Linearization Feature for BCS:**

**Source:**  
**USNWG on Belt-Conveyor Scales**

**Proposal:**

Develop recommended test procedures for NCWM Publication 14, "Belt-Conveyor Scales" to evaluate the use of any linearity correction feature when used in a belt-conveyor scale system.

**Background:**

Manufacturers and service agents of belt-conveyor scales have voiced support for the use of electronic instruments equipped with a linearity correction feature (i.e., multiple point calibrations) to reduce span errors that deviate from a linear pattern. It has been reported by some Sector members that this practice may be considered as non-compliant in some jurisdictions with established weights and measures requirements. Some members of the Sector have asked for clarification from the National Institute of Standards and Technology (NIST), Office of Weights and Measures (OWM) on the use of this type of feature and question whether it is (or should be) permitted under existing U.S. standards.

The U.S. National Work Group (USNWG) on BCS has deliberated on the use of a linearization feature for enhancing the performance of belt-conveyor scale systems and considered whether there is a need to develop additional requirements in NIST Handbook 44 to address its use. At the 2011 BCS Sector Meeting, some members agreed to participate in a sub-group to develop a draft of recommended test procedures that would be submitted to the NTEP Committee as proposed changes within NCWM Publication 14. This group was to also

consider the scope for the application of any newly developed test procedures (i.e., whether the test procedures will be applied retroactively to devices that has already received NTEP approval).

Following the February 2012 NTEP Sector meeting, the sub group met via teleconference. During this Conference (conducted on June 7, 2012), the sub-group agreed that any testing of a linearity correction feature could be performed either in controlled laboratory conditions or in a field installation. The group agreed that if the function of this feature was verified under controlled conditions during type evaluation, it should then be clearly noted on the Certificate of Conformance (CC) for the device. The sub-group also concluded that verification of this feature during field testing, could be accomplished through material tests such as those typically performed during routine official examinations.

In addition, the sub-group agreed that this feature would need to be a sealable function within the instrument. Other points regarding this issue that were discussed at the sub-group's teleconference in June 2012 included:

- The correction factor (linearization factor) must be applied at a minimum of three points or flow rates.
- It is to be determined if there is to be a limitation on the amount of correction permitted. If there is to be a limit established, the sub-group suggests that a limit of  $\pm 0.4$  % of scale capacity may be appropriate.
- The group determined that lab testing should be performed at pre-specified percentages of device capacity to ensure the feature is capable of performing correctly throughout the operating range of the device.
- The group recommended that testing be performed using predetermined correction factors. For instance:
  - flow rates equal to 25 %, 50 %, 75 %, and 90 % of full scale;
  - tests for loading of  $\pm 0.5$  %,  $\pm 1$  %,  $\pm 1.5$  % and  $\pm 2$
  - % of full scale at each flow rate.

**Discussion:**

At the 2014 BCS Sector meeting, the members discussed the advantages and disadvantages of conducting a test both in the field and in the laboratory to verify the function of a linearity correction. Sector Chair, Mr. Bill Ripka stated that to perform this test in the field would be simplified due to the fact that practically every installation of belt-conveyor scale systems will have a certain amount of non-linear performance. This is attributed to various unaccounted influences from the installation and operational details. The test of a linearization correction could therefore be conducted in the field simply by observing the operation of the system while this feature is disabled and then again when the correction has been enabled and comparing these results. If the system is evaluated under controlled conditions in a laboratory environment, a non-linear performance may have to be artificially induced through the use of error weights placed on or removed from the weighing elements while the system is operated.

Also discussed was a limit placed on the amount of correction that would be allowed by a linearization correction feature. It had been suggested by the sub-group that a limit of  $\pm 0.4$  % of scale capacity would be an appropriate value. Some members agreed in general with this limit, however others suggested that this restriction is arbitrary and that it may be overly prescriptive to place any limitation on the amount of correction allowed to the linearity.

While considering a preliminary draft for a test procedure, the Sector could not agree on certain other points regarding all points of the procedure including what tolerance should be applied to the output of a system when linearization is being corrected through the use of this feature.

**Conclusion:**

The BCS Sector agreed that this item needs to be further developed. The original sub-group formed to develop this item agreed to continue work on this item and to produce a draft test procedure that would be circulated for review by the Sector. This draft is scheduled to be available by April 30, 2014, and will then be sent via e-mail to the Sector members.

### **C. Conveyor Belt Profiling:**

**Source:**

**USNWG on Belt-Conveyor Scales**

**Proposal:**

Develop recommended test procedures for NCWM Publication 14, Belt-Conveyor Scales to evaluate the use of a belt profiling feature to provide a zero-load reference when used in a belt-conveyor scale system.

**Background:**

This method of establishing a zero-condition for a totalization operation enables the belt-conveyor scale to synchronize the application of an individual “tare” weight values associated with distinct segments of the belt to the movement of those belt segments over the scale portion of the conveyor. If this alternative to averaging the weight of segments of the belt carcass is used there is a potential need to establish a procedure to evaluate its effectiveness, to ensure that it functions as intended, and is maintained during operation of the BCS.

NIST, OWM has received inquiries seeking guidance on whether this type of feature is permitted under U.S. standards. It is also being reported by some members of the USNWG BCS that some regulatory field officials will not issue an approval for devices equipped with this feature when it is not listed as a standard feature or an option on the NTEP Certificate of Conformance.

During the February 2011 meeting, the Sector members were asked to consider if there is there is a need for procedures to evaluate the effectiveness of belt profiling and to ensure that correct operation is maintained during totalization. A majority of Sector members voiced their opinion that this feature should receive some level of evaluation, and that at a minimum the ability to enable or disable any belt profiling feature should be protected by some form of security seal.

Members at the 2011 BCS Sector meeting also concluded it may be preferable to have the analysis and necessary action(s) for the consideration of belt profiling features taken on by the same work group formed under the previous agenda item.

**Discussion:**

During the 2014 meeting, the BCS Sector was informed that the same sub-group which was assigned to develop procedures for verifying the operation of a linearization correction had also been assigned to develop a procedure for testing the function of belt profiling. No draft procedures have been developed at the time of the 2014 BCS Sector meeting.

Similar to the previous item (linearization correction), the Sector members acknowledged that this feature could readily be tested in the field and would most likely be costlier to test in a laboratory setting. All of the Sector members agreed, this feature must be one protected by a type of security seal.

**Conclusion:**

The Sector agreed to ask the sub-group originally tasked with developing test procedures for the evaluation of this type of feature to continue work on this and to have a draft available by April 30, 2014. This draft will then be shared with Sector members who hold (or have held) regulatory positions for their review and comment. The regulatory-background members will review and prepare their comments by August 1, 2014, at which time the sub-group responsible for developing the draft procedures base the need for further development on those and any other comments provided by Sector members. A final draft will be presented to the Sector at its next meeting for review.

## D. Field Test Procedures for Reference Scales

### Source:

NIST/OWM

### Proposal:

To amend test procedures outlined in NCWM Publication 14, “Belt-Conveyor Scales” with regard to minimum test weights required to certify hopper scales as a reference scale to be used in a materials test. And to align the values provided for minimum test weights with those values as stated in NIST Handbook 44, 2.20. Scales Code.

### Background:

Procedures listed in NCWM Publication 14 for conducting evaluations of belt-conveyor scale systems using material tests, include the following statements:

#### 13. Field Test Procedure

##### Test of the Reference Scale

##### Hopper Scales

Hopper scales must be tested to the used capacity using substitution tests. Test weights equal to a minimum of 10 % of scale capacity are needed; more test weight is recommended. The scale must be accurate to 0.1 % and adjusted if necessary.

During the 2012 BCS Sector meeting, it was noted that the minimum test weight amount of 10 % of scale capacity as stated in NCWM Publication 14 is in conflict with NIST Handbook 44, 2.20. Scales Code, Table 4 where it is required that for scales of greater than 3000 lb capacity the minimum test weight required is 12.5 % of scale capacity. The Sector was asked to consider whether these values should be reconciled. The Sector originally agreed that the statement of 10 % minimum test weight required in NCWM Publication 14 should be amended to coincide with the minimum test weight required under Table 4 – NIST Handbook 44, 2.20. Scales Code (e.g., 12 % of scale capacity).

Further deliberation on this item at the 2012 meeting addressed the fact that NIST Handbook 44 contains no requirement to specify a minimum capacity for a reference scale used and the only specific requirement related to the reference scale is that the scale used must produce weighments within 0.1 % accuracy. Consequently, the members agreed to recommend that NCWM Publication 14 be amended to delete the reference to a 10 % minimum test weight and simply specify that no more than three substitutions can be used during the testing of a hopper scale used a reference scale, and that the hopper scale be tested according to NIST Handbook 44 procedures. These recommended changes are shown below.

#### 13. Field Test Procedure (page BCS-17)

##### Test of the Reference Scale

##### Hopper Scales

Hopper scales must be tested to the used capacity using **a maximum of three** substitution tests **according to NIST Handbook 44 procedures**. ~~Test weights equal to a minimum of 10 % of scale capacity are needed; more test weight is recommended.~~ The scale must be accurate to 0.1 % and adjusted if necessary.

After the 2012 NTEP BCS Sector Meeting, the NIST Technical Advisor received comments from the former Technical Advisor to the Sector regarding concerns about this item and the conclusions of the Sector. These comments were related to the proposed deletion of a stated minimum required test weight and expressed concern that this type of scale may be tested using test weight in amounts that are smaller than what has been established as minimum. Mr. Ripka, BCS Sector Chair, and Mr. Truex, NTEP Administrator, were consulted with regard to the concerns expressed, and a decision was reached that these concerns have merit and since this item is not a

critical issue currently preventing a manufacturer from completing an NTEP evaluation. It would be best to table this issue as a carry-over item to be further addressed at the next Sector meeting.

**Discussion:**

At the 2014 meeting, the BCS Sector was asked to re-evaluate the conclusions made during the 2012 meeting and to consider concerns expressed over the proposal to eliminate any statement of required minimum test weights needed.

There was a general discussion regarding variations between the minimum test weight requirement in this particular section of NCWM Publication 14 and the minimum test weight required on hopper-type scales of a capacity and division size that would be commonly used as a reference scale in a material test on BCS systems. Additional points made were that during an NTEP test of this type of weighing device, a minimum test weight of 25 % of scale capacity is required.

Other comments made during the 2014 meeting pointed out the disparity of applying a minimum of 10 % of scale capacity and the confidence in test results when the scale is used much closer to its nominal capacity, even when substitution testing is performed on this type of device.

**Conclusion:**

The BCS Sector agreed that a statement regarding the minimum amount of test weight required for a test on a hopper scale used as a reference scale to test BCS systems should be retained. It was also agreed that the minimum test weight required in this section of NCWM Publication 14 should be aligned with the minimum test weight requirements (12.5 % of nominal scale capacity) as stated in NIST Handbook 44 for this type of weighing device. The following revised draft will be forwarded to the NTEP Administrator as a recommendation from the Sector for a change in the appropriate location in NCWM Publication 14.

**13. Field Test Procedure (page BCS-17)**

**Test of the Reference Scale**

**Hopper Scales**

Hopper scales must be tested to the used capacity using a maximum of three substitution tests according to NIST Handbook 44 procedures. Test weights equal to a minimum of ~~10 %~~ 12.5 % of nominal scale capacity are needed; more test weight is recommended. The scale must be accurate to 0.1 % and adjusted if necessary.

**II. New items**

**A. 2014 NIST Handbook 44 Changes**

**Source:**

USNWG on Belt-Conveyor Scales

**Proposal:**

Amend NCWM Publication 14, Belt-Conveyor Scales to correspond with changes that have occurred in the most recent edition of NIST Handbook 44.

**Background:**

The following items involve changes that were adopted through the NCWM and are now incorporated into the 2014 edition of NIST Handbook 44. The content of NCWM Publication 14 for BCS Checklists and Test Procedures for BCS Systems should reflect any relevant changes occurring in the current edition of NIST Handbook 44. The BCS Sector was asked to review and comment on the recommended changes to NCWM Publication 14 that would align these publications. The proposed changes to NCWM Publication 14 are shown in the following two items listed under II.A.1). and II.A.2). in this summary.

1) **Appendix C – Units of Mass (ton)**

**Source:**

Mr. Paul Lewis, Rice Lake Weighing Systems, Inc./NTEP Weighing Sector

**Background:**

Adopted changes to the 2014 edition of NIST Handbook 44 include the results of efforts to standardize abbreviations used for the term “short ton.” These changes affected the Units of Mass Table appearing on pages C-19 and C-20 of Appendix C. This change resulted in the elimination of abbreviations for the term “short ton” other than “tn” when used on equipment manufactured after the effective date of January 1, 2014. Equipment manufactured between January 1, 2008, and December 31, 2013, may use an abbreviation other than “tn.”

The amendment also included the addition of a footnote to the Table mentioned above intended to clarify that abbreviations for “net” or “short” ton other than “tn” are considered appropriate for use with older equipment as follows:

<b>Units of Mass</b>	
1 ton, metric (t)	2204.623 pounds 0.984 gross ton 1.102 net tons
1 ton, net or short ( <b>tn</b> ) <sup>21</sup>	2000 pounds (exactly) 0.893 gross ton 0.907 metric ton

**<sup>21</sup>As of January 1, 2014, “tn” is the required abbreviation for short ton. Devices manufactured between January 1, 2008, and December 31, 2013, may use an abbreviation other than “tn” to specify short ton.**

An additional change associated with this item was made in NIST Handbook 44 in the Avoirdupois Units of Mass heading on page C-6 of Appendix C as shown in following table.

<b>Avoirdupois Units of Mass</b>	
[The “grain” is the same in avoirdupois, troy, and apothecaries’ units of mass.]	
1 μlb	= 0.000 001 pound (lb)
27 <sup>11/32</sup> grains (gr)	= 1 dram (dr)
16 drams	= 1 ounce (oz)
	= 437½ grains
16 ounces	= 1 pound (lb)
	= 256 drams
	= 7000 grains
100 pounds	= 1 hundredweight (cwt) <sup>6</sup>
20 hundredweights	= 1 ton <del>(t)</del> ( <b>tn</b> ) <sup>x</sup>
	= 2000 pounds <sup>7</sup>
In “gross” or “long” measure, the following values are recognized:	
112 pounds (lb)	= 1 gross or long hundredweight (cwt) <sup>7</sup>
20 gross or long hundredweights	= 1 gross or long ton
	= 2240 pounds <sup>7</sup>
<p><sup>6</sup> When necessary to distinguish...</p> <p><sup>7</sup> When the terms “hundredweight” and.....</p> <p><b><u><sup>x</sup>As of January 1, 2014, “tn” is the required abbreviation for short ton. Devices manufactured between January 1, 2008, and December 31, 2013, may use an abbreviation other than “tn” to specify short ton.</u></b></p>	

To align NCWM Publication 14 for Belt-Conveyor Scales (BCS) with the changes above, it is recommended that Sections 1.8 and 2.5 in the NCWM Publication 14 for BCS Checklists and Test Procedures be amended as follows.

This publication is available free of charge from: <https://doi.org/10.6028/NIST.SP.1210>

**1 Indicating and Recording Elements**

- 1.8 The scale division shall be in increments of 1, 2, or 5 times  Yes  No  N/A  
 10 k where k is an integer and shall not be greater than 0.125 %  
 ( $1/800$ ) of the minimum totalized load.  
 What is a scale division?

Unit	Abbreviation
pounds	lb or LB
U.S. short ton	ton or <del>T</del> tn
U.S. long ton	LT
Metric ton	t
kilograms	kg

**2 Recording Element**

- 2.5 Information required on the ticket  Yes  No  N/A

MASTER START TOTAL	05 06 92
MASTER STOP TOTAL	15:30
QUANTITY	44113.5 <del>T</del> tn
	44300.5 <del>T</del> tn
	187.0 <del>T</del> tn

While considering this item at their 2013 meeting, the NTEP Weighing Sector reviewed the list of acceptable abbreviations/symbols found in Appendix C of NCWM Publication 14, Digital Electronic Scales (DES). The Weighing Sector proposed changes to this document and forwarded those proposed changes to the Belt-Conveyor Scale Sector for additional input recognizing these proposed changes might impact BCS manufactures more significantly than manufacturers of other types of scales.

The Weighing Sector has recommended changes to the NCWM Publication 14 for DES Appendix C – Acceptable Abbreviations/Symbols as follows:

*From NCWM Publication 14 for DES:*

*[Note: The following excerpt from NCWM Publication 14 has been edited to include only the portions relevant to this agenda item.]*

In addition, the Weighing Sector considered the appropriate use of the entire word “ton” under this item. It is now being recognized that the word “ton,” when used by itself should be used only in conjunction with the unit “short ton” and should not be intended, nor should it be permitted, to represent any other version of the ton unit (e.g., long ton, metric ton).



This publication is available free of charge from: <https://doi.org/10.6028/NIST.SP.1210>

<b>Appendix C</b>			
<b>Acceptable Abbreviations/Symbols</b>			
<p>This list does not standardize the abbreviations/symbols that must be used, rather, it identifies abbreviations/symbols that are routinely acceptable. This list is not limiting or all-inclusive; other abbreviations/symbols may be acceptable. Additionally, the following lists of abbreviations and symbols should be used as a guide; style differences are acceptable (e.g., shapes of arrows,)</p>			
<b>Device Application</b>	<b>Term</b>	<b>Acceptable</b>	<b><u>NOT</u> Acceptable</b>
General	value of scale division (displayed)	d	
	value of verification scale division	e	
	number of scale divisions	n	
	gross	gross, G, GR	
	Semi-automatic (push-button) tare	tare, T, TA	
	Keyboard, Programmable and Stored tare	tare, T, TA, PT	
	net	net, N, NT	
	pieces	pieces pc, pcs	
	count	count cnt or pc(s) <i>is encouraged or ct symbol for pieces ct is acceptable NIST Handbook 130</i>	C
	carat or carat troy – 200 mg	c <i>NIST Handbook 44 and NIST Guide for the Use of International System of Units (SI)</i>	ct <i>not permitted if used as the abbreviation for carat and count on a scale with an enable count feature</i>
	<b><u>short ton</u></b>	<b><u>ton or tn</u></b>	
*Exceptions to General Tables of <i>NIST Handbook 44</i>	carat or carat troy – 200 mg	ct <i>common jewelry industry abbreviation and is the only acceptable abbreviation in Canada</i>	ct <i>not permitted if used as the abbreviation for carat and count on a scale with an enable count feature</i>
	U.S. short ton	<del>ton, TN, or tn</del> - <i>for belt-conveyor scales the abbreviation "T" is acceptable</i>	
	U.S. long ton	LT	
	Grain	grain, GRN, grn, GN	
Belt-Conveyor Scales	U.S. short ton (different from "General" application)	T	

**Discussion:**

During the BCS Sector meeting in February 2014, the members acknowledged the changes that occurred in NIST Handbook 44 and the use of multiple abbreviations to identify the term “short ton” can lead to misunderstandings. It was also pointed out that the use of the upper case “T” as an abbreviation for this unit could be confused with the use of that abbreviation in connection with the term “tare” on certain indicating or recording elements. At the 2014 meeting, Sector members also considered the changes to NCWM Publication 14 (DES) recommended by the Weighing Sector.

The BCS Sector had few additional comments on this item however, the importance for the alignment of NCWM Publication 14 and NIST Handbook 44 was recognized by the members.

**Conclusion:**

At the 2014 meeting, the BCS Sector members indicated their support for the proposal to amend Sections 1.8 and 2.5 in the NCWM Publication 14 for BCS Checklists and Test Procedures as shown above. They also agreed with the Weighing Sector and supported the changes to Appendix C of NCWM Publication 14, Digital Electronic Scales (DES) as noted above.

2) **Deletion of /minimum required maximum conveyor lengths**

**Source:**

USNWG on Belt-Conveyor Scales

The 2014 edition of NIST Handbook 44, BCS code has been amended by the deletion of paragraph UR.1.2.(h). This amendment eliminated the sub-paragraph that previously provided the allowable limits for maximum and minimum conveyor length in commercial BCS systems. To reflect this change, it is recommended that Section 9.7.1 in NCWM Publication 14 for BCS be changed as shown below:

**Code Reference: UR.2.2.1.**

9.7. The design and installation of the conveyor leading to and from the belt-conveyor scale ...

⋮

~~9.7.1. The conveyor shall be no longer than 1000 ft (300 m) or shorter than 40 ft (12 m) from head to tail pulley.~~  Yes  No  N/A  
~~{Nonretroactive as of January 1, 1986}~~

**Discussion/Conclusion:**

During the 2014 meeting, the BCS Sector had no additional comments on this item. The members agreed to support the recommended changes to NCWM Publication 14 for BCS as shown above.

## B. Proposals recommended by the NTEP Software Sector

**Source:**  
NTEP Software Sector

**Proposal:**  
Amend NCWM Publication 14 to address perceived gaps in the identification, protection/security, and the maintenance of software used in electronic weighing systems.

**Background:**  
The NTEP Software Sector has made three proposals regarding the regulation of software used in electronic weighing devices. These proposals have been circulated to the other NTEP Sectors for review and comment. The three proposals are listed individually below and were considered as separate items during the 2014 BCS Sector meeting.

*[Technical Advisor's note: The discussions and conclusions regarding each of the three items are shown below under "Discussion" and "Conclusion" in the order that the items were presented to the Sector at its 2014 meeting]*

### 1) Identification of Certified Software

This item originated as response to the question "How does the field inspector know that the software running in the device is the same software evaluated and approved by the lab?" It has been recognized that the international community has already addressed this issue (i.e., through WELMEC and OIML).

There was a discussion at the 2012 NTEP Software Sector Meeting, focusing on where the terminology regarding inextricably linking the software version or revision to the software itself belonged. The Software Sector recommended adding the following to NCWM Publication 14 and forward to NTEP Weighing, Measuring, and Grain Analyzer Sectors for feedback:

#### **Identification of Certified Software:**

Note: Manufacturers may choose to separate metrologically significant software from non-metrologically significant software. Separation would allow the revision of the non-metrological portion without the need for further evaluation. In addition, non-metrologically significant software may be updated on devices without breaking a seal, if so designed. Separation of software requires that all software modules (programs, subroutines, objects, etc.) that perform metrologically significant functions or that contain metrologically significant data domains form the metrologically significant software part of a measuring instrument (device or sub-assembly). If the separation of the software is not possible or needed, then the software is metrologically significant as a whole. The conformity requirement applies to all parts and parts shall be marked according to Section G-S.X.X.

The manufacturer must describe and possibly demonstrate how the version or revision identifier is directly and inseparably linked to the metrologically significant software. Where the version revision identifier is comprised of more than one part, the manufacturer shall describe which portion represents the metrological significant software and which does not.

The BCS Sector is being asked to review and comment on a proposal developed by the NTEP Software Sector. This proposal recommends that marking requirements be established for software-based electronic equipment that will enable field verification of the appropriate version or revision for

metrological software. This proposal would include changes to language in NIST Handbook 44 so that U.S. standards would be more closely aligned with international requirements found in standards published by WELMEC (European Cooperation in Legal Metrology) and OIML (International Organization of Legal Metrology).

The Software Sector recognized a number of points during the development of this proposal including:

- It is the opinion of the Software Sector that a specific method of identification of software version or revision should not be defined but rather that the manufacturer should utilize a method and demonstrate the selected identification mechanism is suitable for the purpose.
- A category III or some comparable means of providing a seal for metrological software would provide an indication to the weights and measures inspector that any changes have been made to the software.

The Software Sector has requested that the other NTEP Sectors review this proposal and provide feedback.

## 2) **Software Protection/Security**

The Software Sector is proposing that the existing audit trail and physical seal provisions used in the United States to provide security of the software used in software-based devices needs to be enhanced. To accomplish this, the Software Sector has referenced the international WELMEC Document as shown below:

**Protection against accidental or unintentional changes:**

Metrologically significant software and measurement data shall be protected against accidental or unintentional changes.

**Specifying Notes:**

Possible reasons for accidental changes and faults are: unpredictable physical influences, effects caused by user functions and residual defects of the software even though state of the art of development techniques have been applied.

This requirement includes consideration of:

- a) Physical influences: Stored measurement data shall be protected against corruption or deletion when a fault occurs or, alternatively, the fault shall be detectable.
- b) User functions: Confirmation shall be demanded before deleting or changing data.
- c) Software defects: Appropriate measures shall be taken to protect data from unintentional changes that could occur through incorrect program design or programming errors, for example, plausibility checks.

**Required Documentation:**

The documentation should show the measures that have been taken to protect the software and data against unintentional changes.

**Example of an Acceptable Solution:**

- The accidental modification of software and measurement data may be checked by calculating a checksum over the relevant parts, comparing it with the nominal value and stopping if anything has been modified.
- Measurement data are not deleted without prior authorization, for example, a dialogue statement or window asking for confirmation of deletion.
- For fault detection see also Extension I.

The Software Sector is in the process of developing a checklist for inclusion in NCWM Publication 14. This checklist is based roughly on a checklist contained in the international standard for non-automatic weighing instruments, OIML R 76-2. The information requested by this checklist is currently voluntary; however, it is recommended that NTEP applicants comply with these requests or provide specific information as to why they may not be able to comply. Based on this information, the checklist may be amended to better fit with NTEP's need for information and the applicant's ability to comply.

The California, Maryland, and Ohio laboratories agreed to use this check list (shown below) on one of the next devices they have in the lab and report back to the Sector on what the problems may be. North Carolina's laboratory was also given a copy of the check list to try.

1. **Devices with ~~Embedded Software~~ TYPE P (~~aka built for purpose~~)**

1.1. Declaration of the manufacturer that the software is used in a fixed hardware and software environment.  Yes  No  N/A **AND**

1.2. Cannot be modified or uploaded by any means after securing/verification.  Yes  No  N/A

*Note: It is acceptable to break the "seal" and load new software, audit trail is also a sufficient seal.*

1.3. The software documentation contains:

1.3.1. Description of all functions, designating those that are considered metrologically significant.  Yes  No  N/A

1.3.2. Description of the securing means (evidence of an intervention).  Yes  No  N/A

1.3.3. Software Identification, **including version/revision**  Yes  No  N/A

1.3.4. Description how to check the actual software identification.  Yes  No  N/A

1.4. The software identification is:

1.4.1. Clearly assigned to the metrologically significant software and functions.  Yes  No  N/A

1.4.2. Description how to check the actual software identification.  Yes  No  N/A

1.4.3. Provided by the device as documented.  Yes  No  N/A

1.4.4. **Directly linked to the software itself.**  Yes  No  N/A

2. **~~Personal Computers, Instruments with PC Components, and Other Instruments, Devices, Modules, and Elements with Programmable or Loadable Metrologically Significant Software~~ TYPE U (~~aka not built for purpose~~)**

2.1. The metrologically significant software is:

2.1.1. Documented with all relevant (see below for list of documents) information.  Yes  No  N/A

2.1.2. Protected against accidental or intentional changes.  Yes  No  N/A

2.1.3. Evidence of intervention (such as, changes, uploads, circumvention) is available until the next verification/inspection (e.g., physical seal, Checksum, **Cyclical Redundancy Check (CRC)**, audit trail, etc. means of security).  Yes  No  N/A

3. **Software with ~~Closed Shell~~ (no access to the operating system and/or programs possible for the user)**

- 3.1. Check whether there is a complete set of commands (e.g., function keys or commands via external interfaces) supplied and accompanied by short descriptions.  Yes  No  N/A
- 3.2. Check whether the manufacturer has submitted a written declaration of the completeness of the set of commands.  Yes  No  N/A

4. **Operating System and / or Program(s) Accessible for the User**

- 4.1. Check whether a checksum or equivalent signature is generated over the machine code of the metrologically significant software (program module(s) subject to legal control Weights and Measures jurisdiction and type-specific parameters).  Yes  No  N/A
- 4.2. Check whether the metrologically significant software will detect and act upon any unauthorized alteration of the metrologically significant software using simple software tools (e.g., text editor).  Yes  No  N/A

5. **Software Interface(s)**

5.1. Verify the manufacturer has documented:

- 5.1.1. The program modules of the metrologically significant software are defined and separated.  Yes  No  N/A
- 5.1.2. The protective software interface itself is part of the metrologically significant software.  Yes  No  N/A
- 5.1.3. The functions of the metrologically significant software that can be accessed via the protective software interface.  Yes  No  N/A
- 5.1.4. The parameters that may be exchanged via the protective software interface are defined.  Yes  No  N/A
- 5.1.5. The description of the functions and parameters are conclusive and complete.  Yes  No  N/A
- 5.1.6. There are software interface instructions for the third party (external) application programmer.  Yes  No  N/A

The NTEP laboratories have used the above checklist on a limited basis and already have provided some feedback to the Software Sector. Work is ongoing on this item with the intent that it eventually will be incorporated as a checklist in NCWM Publication 14; again the laboratories are requested to try utilizing this checklist for any evaluations on software-based electronic devices. The revised checklist will be distributed to the laboratories for additional review.

The other NTEP Sectors are being asked to review and provide additional feedback.

### 3) Software Maintenance and Reconfiguration

The Software Sector has requested that the other NTEP Sectors review the recommended changes to *NCWM Publication 14* with regard to the means used by device manufacturers to insure the integrity of the software in their devices.

The Software Sector asked the question: “What do the software-based device manufacturers use to secure their software?” The following items were reviewed by the Sector and passed to the other Sectors for review.

1. Verification that the update process is documented (OK)

2. For traced updates, installed Software is authenticated and checked for integrity

Technical means shall be employed to guarantee the authenticity of the loaded software (i.e., that it originates from the owner of the type approval certificate). This can be accomplished (e.g., by cryptographic means like signing). The signature is checked during loading. If the loaded software fails this test, the instrument shall discard it and either use the previous version of the software **or become inoperative**.

Technical means shall be employed to guarantee the integrity of the loaded software i.e., that it has not been inadmissibly changed before loading. This can be accomplished e.g., by adding a checksum or hash code of the loaded software and verifying it during the loading procedure. If the loaded software fails this test, the instrument shall discard it and either use the previous version of the software **or become inoperative**.

Examples are not limiting or exclusive.

3. Verify that the sealing requirements are met

The Sector asked, “What sealing requirements are we talking about?”

This item is **only** addressing the **software update**; it can be either verified or traced. It is possible that there are two different security means, one for protecting software updates (software log) and one for protecting the other metrological parameters (Category I II or III method of sealing). Some examples provided by the Sector members include but are not limited to:

- Physical Seal, software log
- Category III method of sealing can contain both means of security

4. Verify that if the upgrade process fails, the device is inoperable or the original software is restored

The question before the group is, “Can this be made mandatory?”

The manufacturer shall ensure by appropriate technical means (e.g., an audit trail) that traced updates of metrologically significant software are adequately traceable within the instrument for subsequent verification and surveillance or inspection. This requirement enables inspection authorities, which are responsible for the metrological surveillance of legally controlled instruments, to back-trace traced updates of metrologically significant software over an adequate period of time (that depends on national legislation). The statement in italics will need to be reworded to comply with U.S. weights and measures requirements.



The Sector **agreed** that the two definitions below for Verified update and Traced update were acceptable.

**Verified Update**

A verified update is the process of installing new software where the security is broken and the device must be re-verified. Checking for authenticity and integrity is the responsibility of the owner/user.

**Traced Update**

A traced update is the process of installing new software where the software is automatically checked for authenticity and integrity, and the update is recorded in a software update log or audit trail.

*Note: It's possible that the Philosophy of Sealing section of NCWM Publication 14 may already address the above IF the definitions of Verified and Traced Updates (and the statement below) were to be added. The contrary argument was that it may be better to be explicit).*

**Use of a Category 3 audit trail is required for a Traced Update. A log entry representing a traced software update shall include the software identification of the newly installed version.**

The Sector recommended consolidating the definitions with the above statement thus:

**Verified Update**

A verified update is the process of installing new software where the security is broken and the device must be re-verified. Checking for authenticity and integrity is the responsibility of the owner/user.

**Traced Update**

A traced update is the process of installing new software where the software is automatically checked for authenticity and integrity, and the update is recorded in a ~~software update log or~~ Category 3 audit trail. The audit trail entry shall include the software identification of the newly installed version.

In 2012, the Sector recommended that as a first step, the following be added to NCWM Publication 14:

**The updating of metrologically significant software, including software that checks the authenticity and integrity of the updates, shall be considered a sealable event.**

Though the Software Sector is currently considering only that the single sentence (shown above) be incorporated into NCWM Publication 14 there may be additional changes proposed in the future.

**Discussion:**

II.B.1. Identification of Certified Software:

During the 2014 meeting, the BCS Sector was provided with background information and explanation of these three items by NTEP Administrator, Mr. Jim Truex. Each of the three items was considered by the BCS Sector members separately and the discussion and conclusions from the BCS Sector members regarding each item are listed in the same sequence as they appear in the above background information.

The Sector members were informed that language that had been drafted regarding the identification of certified software represented a recommendation to notify software developers/providers that it may be beneficial to separate software developed for use with commercial weighing and measuring devices into two components. One of the components would be associated with the general function of the equipment and the other component would consist of any software affecting metrological features of a device. This separation would facilitate the ability to provide a means for sealing (physical or electronic) the metrological significant functions while allowing the general-purpose functions and features to remain with unrestricted access. This separation of different parts of software may have more significance if

and when software programs that are associated with legal metrology devices are type evaluated under NTEP.

Some Sector members who are device manufacturers indicated that this approach may be of no consequence to their operation due to the fact that the software used in the devices they produce is developed for the sole purpose of operating their weighing equipment. Therefore, all portions of the software will have metrological effect and will need to be protected by means of a security seal. None of the Sector members however, objected to including this language as a general statement to provide an indication of what is anticipated to be incorporated as regulation in the future.

#### II.B.2. Software Protection/Security:

At their 2014 meeting, the BCS Sector members were informed by Mr. Truex that this proposal from the Software Sector provides a checklist to be used in type evaluation of software used in association with commercial weighing and measuring devices. This checklist has been derived from principles found in the WELMEC Document 2.3 and details in OIML R 76 and is being proposed to be included in NCWM Publication 14.

Also at the 2014 meeting, the Sector was informed that this checklist has been used on a trial basis by NTEP laboratories in the United States. The trial implementation of the checklist in these NTEP laboratories has reportedly identified some problems as well as a certain amount of usefulness. Also noted was that some portions of the checklist were not clearly understood by the evaluators. The Sector was also provided with a number of objections to this checklist that were identified by the Weighing Sector during their review of this proposal. These objections are as follows:

- this proposal would seem to apply to all devices and is not applied in a non-retroactive fashion;
- the distinction between software that has, and that which does not have metrological effects is not clear in the proposal – particularly regarding the need to break security seals when loading software;
- all elements of this checklist are not supported by requirements currently found in NIST Handbook 44; and
- some terms used in the proposed checklist are not defined or clearly understood.

#### II.B.3. Software maintenance and reconfiguration:

The Sector was in general agreement with the notion that software updates should be recorded as changes within an electronic sealing means (i.e., audit trail). The members however expressed concern over their lack of understanding for the meaning of the portion of this proposed language that states: "...including software that checks the authenticity and integrity of the updates." Some Sector members questioned whether software that has been installed in the system to only validate updates to metrologically significant software would actually be considered as a parameter to be tracked in an audit trail. The Sector generally agreed that this wording is not clear in the proposal and suggested that this point be clarified.

Another point discussed by the Sector members was whether this proposal would apply to all devices retroactively. They agreed that this would be problematic if devices already in service would need to be reprogrammed to comply with this proposal.

#### **Conclusions:**

##### II.B.1. Identification of Certified Software:

The BCS Sector agreed to support the inclusion of the information as shown under "Identification of Certified Software" in to NCWM Publication 14. The members did however recommend that the last

sentence of the first paragraph (“The conformity requirement applies to all parts and parts shall be marked according to Section G-S-X.X.”) be omitted. This recommendation is in support of the recommendation made by the Weighing Sector in their review of this item.

II.B.2. Software Protection / Security:

The BCS Sector members agree with the conclusions of the Weighing Sector and do not support the proposed inclusion of the checklist within NCWM Publication 14.

II.B.3. Software Maintenance and Recognition:

The BCS Sector members had questions regarding this proposal and do not believe that it has been sufficiently developed. The meaning of the last portion of the proposed additional language “...including software that checks the authenticity and integrity of the updates, shall be considered a sealable event” is unclear. The BCS Sector agrees largely with the conclusions of the Weighing Sector and does not support the proposed inclusion of the checklist within NCWM Publication 14 at this time.

**C. Review of NCWM Publication 14 List of Sealable Parameters for BCS Systems**

**Source:**

USNWG on Belt-Conveyor Scales.

**Proposal:**

To review and further develop (if necessary) a list of features associated with a BCS system (and weigh-belt systems) that will categorize those features as either sealable or non-sealable.

**Background:**

The list shown below was developed during the 2009 - 2010 NTETC BCS Sector meetings. The table was then incorporated in the 2011 edition of Publication 14. NTEP laboratories were asked to report back to the Sector with comments and recommended amendments for improvement. Since there have not been any responses received by the Sector at this point, it is not known if any manufacturers' devices have been submitted for NTEP approval to apply this list to during any evaluations.

<b>Belt-Conveyor Scale Features and Parameters</b>	
<b>Typical Features to be Sealed</b>	<b>Typical Features and Parameters Not Required to be Sealed</b>
Official verification zero reference Official verification span/calibration reference Linearity correction values Allowable range of zero (if adjustable) Selection of measurement units Division value, d Range of overcapacity indications (if it can be set to extend beyond regulatory limits) Alarm limits for flow rate (high/low) Automatic zero-setting mechanism (on/off) Automatic zero-setting mechanism (range of a single step) Configuration (speed, capacity, calibrated test weight value if applicable, pulses per belt revolution, load cell configuration,)	Display update rate Baud rate for electronic data transfer Communications (Configuration of input, output signal to peripheral devices)
<p><i><b>NOTE:</b> The above examples of adjustments, parameters, and features to be sealed are to be considered "typical" or "normal." This list may not be all inclusive, and there may be parameters other than those listed which affect the metrological performance of the device and must, therefore, be sealed. If listed parameters or other parameters which may affect the metrological function of the device are not sealed, the manufacturer must demonstrate that the parameter will not affect the metrological performance of the device (i.e., all settings comply with the most stringent requirements of Handbook 44 for the applications for which the device is to be used).</i></p>	

**Discussion:**

In view of the proposals submitted by the NTEP Software Sector that are included in this agenda, it was recommended by Mr. Ripka, (Chair) that the Sector members review this table for completeness.

During the 2014 BCS Sector meeting, it was recommended that belt-profiling should be added as a sealable parameter in the table. No objections were heard regarding this suggested amendment.

There were a variety of other features discussed that in certain circumstances could be considered as sealable features in a BCS system. Mr. Peter Sirrico suggested that communications should not be located under the non-sealable parameters as it currently appears in the table but should rather be listed as a sealable parameter due to the ability in some devices to input changes to metrological features of the device through the communications portal. Additionally, it was suggested that baud-rate should also be relocated from the non-sealable parameters column to the sealable parameters column. Most members conceded that if the communications portal offered a means of input to change metrological features, then the communications (i.e., configuration of connection to metrologically significant peripheral devices) should appear in the sealable column. Not all members were in support of the similar change suggested regarding the baud rate.

This publication is available free of charge from: <https://doi.org/10.6028/NIST.SP.1210>

There was additional discussion regarding the effects that the various features or functions in this table have on metrological aspects of a BCS system which led the Sector members to conclude that an argument could be made to place practically all features/functions under the sealable parameters column in the table.

**Conclusion:**

There was no consensus among Sector members to finalize any revision to the existing table in NCWM Publication 14 and it was agreed that the table should undergo a trial usage by NTEP evaluators when possible and that any necessary changes would be addressed by the BCS Sector afterwards. The discussion for the amendment of this table will be placed on the agenda of the next Sector meeting.

**III. Attendance**

**James Alexander**  
SME Scales DTE Energy  
6200 W. Warren  
Detroit, MI 48210  
(313) 897-1143  
[jalexander@dteenergy.com](mailto:jalexander@dteenergy.com)

**Al Page**  
Montana Highlands  
2316 Canyon Drive  
Billings, MT 59102  
(406) 861-0534  
[awp8866@gmail.com](mailto:awp8866@gmail.com)

**John Barton**  
NIST, Office of Weights and Measures  
100 Bureau Drive  
MS 2600  
Gaithersburg, MD 20899  
(301) 975-4002  
[john.barton@nist.gov](mailto:john.barton@nist.gov)

**Bill Ripka**  
Thermo Fisher Scientific  
501 90th Avenue, NW  
Minneapolis, MN 55433  
(800) 445-3503  
[bill.ripka@thermofisher.com](mailto:bill.ripka@thermofisher.com)

**Paul Chase**  
Chase Technology, Inc.  
502 Erie Avenue  
Crosby, MN 56441  
(218) 545-2356  
[mjc@crosbyironton.net](mailto:mjc@crosbyironton.net)

**Peter Sirrico**  
Thayer Scale/Hyer Industries  
91 Schoosett Street  
Pembroke, MA 02359  
(781) 826-8101 x328  
[psirrico@thayerscale.com](mailto:psirrico@thayerscale.com)

**Nathan Gardner**  
State of Oregon Measurement Standards  
635 Capital Street, NE  
Salem, OR 97301  
(503) 881-4586  
[ngardner@oda.state.or.us](mailto:ngardner@oda.state.or.us)

**James Truex**  
National Conference on Weights and Measures  
88 Carryback Drive  
Pataskala, OH 43062  
(740) 919-4350  
[jim.truex@ncwm.net](mailto:jim.truex@ncwm.net)

**Ken Jones**  
California Division of Measurement Services  
6790 Florin Perkins Road, Suite 100  
Sacramento, CA 95828  
(916) 229-3052  
[kjones@cdfa.ca.gov](mailto:kjones@cdfa.ca.gov)

## Attachment A – BCS Publication 14 Checklist for Master Weight Totalizers (MWT)

Recommended change/addition to NCWM Publication 14 Belt Conveyor Scales

July 10, 2008

Revised 6-16-2014

For Providing MWT testing as a stand-alone device

***Technical Advisor's note:** This draft was originally developed largely upon existing NCWM Publication 14 content. This document is intended as an appendix to the existing Publication 14 for the evaluation of master weight totalizers (MWT) to be used as replacement instruments for retrofit in existing belt-conveyor scale systems. This revision of the original (July 2008) document contains those changes considered by NTEP Belt-Conveyor Scale Sector members via e-mail correspondence and teleconference in June 2014. The new changes that are now recommended by the Sector are shown below **in bold type**. Deleted language is shown in ~~strikethrough font~~ and newly added language is underlined.*

### Appendix C

#### Evaluation of stand-alone master weight totalizers

(A MWT submitted for approval as a stand-alone device can only be accepted as an addition to an existing CoC for a complete Belt Conveyor Scale System.)

##### A. Models to be Submitted for Evaluation

A type is a model or models of the same design, as defined in the NTEP Policy and Procedures. A complete list and description of all models of a type to be included in the Certificate of Conformance (CC) shall be submitted with the request for type evaluation. All options and features to be included on the CC must be submitted for evaluation. If the CC is to include more than one model of the same type, the submitter shall contact the evaluation agency to determine which model or models will be evaluated. A CC will be amended when new models of the same type meeting the specified criteria, are applied for by the manufacturer.

The models to be submitted for evaluation shall be those having:

- a. Laboratory Test – A master weight totalizer (MWT) or integrator that, at a minimum meets the requirements of the original evaluation, with defined enhancements and additional options indicated. The submitter shall also provide all necessary devices or instruments to represent the load receiving and speed sensing elements.
- b. Field Test – The field test shall be performed with a previously “approved for commercial use” weighbridge model by the same manufacturer.

##### B. Certificate of Conformance Parameters

A Certificate of Conformance (CC) will apply to all models that have:

- Equivalent hardware and software
- Subsets of standard options and features of the equipment evaluated.

Metrological features not recognized by Handbook 44, but capable of being used as the basis for commercial transactions, shall be capable of being disabled and sealed before the device can receive an NTEP Certificate of Conformance.

### C. Replacement Parts

The policy for addressing the conformance of replacement parts with the parts being replaced is:

1. If a Master Weight Totalizer (MWT) has received an NTEP evaluation and an NTEP Certificate of Conformance, it must be repaired with parts that are consistent with the design or metrologically equivalent parts.

### D. Substitution of the Master Weight Totalizer

For a master weight totalizer (MWT) to be considered an appropriate substitute for the MWT tested during the original type evaluation of a belt-conveyor scale system, **each of** the following criteria must be satisfied:

1. The MWT must be tested in the laboratory using appropriate load and speed signal simulators capable of being adjusted within the tolerances indicated in the checklists and tables in this document;
2. All MWT laboratory tests must be performed on the replacement MWT, including temperature testing;
3. During the test, the device must be within the acceptance tolerance;
4. A field test will be performed meeting ~~new initial installation~~ **NIST Handbook 44, Belt-Conveyor Scales Systems Code Sections N.2., N.3.1. and N.3.2.** testing criteria;
- ~~5. A field permanence test will be performed, and~~
- 56** A separate Certificate of Conformance (CC) will not be issued for the new MWT. Instead, the original CC will be amended to include the new MWT as an option; and
- ~~67~~ Application limits such as capacity and speed ranges established during the original type evaluation will not be amended.

### E. Checklist and Test Procedures

#### 1. Indicating and Recording Elements

The integrator of a belt conveyor scale normally includes the master weight totalizer (MWT) and a rate of flow indicator and rate of flow alarms. The master weight totalizer must have adequate resolution to be able to establish a valid zero reference value and must have sufficient capacity to totalize loads over a reasonable period of time. The integrator may also have a resettable partial totalizer for indicating the mass of loads conveyed over a limited period of time and may have a supplementary totalizer with a scale interval greater than that of the master weight totalizer that will indicate the mass of loads conveyed over a fairly long period of operation. The partial totalizer is normally used for indicating the values for the zero test, simulated load tests, materials tests, and individual measurements of interest to the scale owner.

The master weight totalizer shall be equipped with provisions for applying a security seal that must be broken or another approved security means before any change that affects the metrological integrity of the device can be made to the master weight totalizer.

- 1.1 The scale must have a master weight totalizer Yes  No  N/A
- 1.2 The MWT shall not be resettable without breaking a security means. Yes  No  N/A
- 1.3 A power failure test must be conducted on digital electronic MWT's both in the laboratory and in the field permanence test. Yes  No  N/A

**Test Procedure**

- 1.3.1 Accumulate a measured quantity on the MWT and stop the flow of material. Note the reading. Yes  No  N/A
- 1.3.2 Disconnect power to the MWT. Yes  No  N/A
- 1.3.3 Connect Power to the MWT. Yes  No  N/A
- 1.3.4 The quantity indication shall return to the previously displayed quantity within 1 division. Yes  No  N/A

**Laboratory Test:** The accumulated measured quantity for the MWT is retained in memory during a power failure of 24 hours and is displayed again when power is returned.

~~**Field Test:** The accumulated quantity for the MWT is retained in memory during a power failure of 10 seconds up to 24 hours and is displayed again when power is returned.~~

- 1.4 The capacity of the MWT shall be at least 10 hours times the maximum rated. Flow rate indicated on the original CC. Yes  No  N/A
- 1.5 The value of the scale division shall be capable of being established for a value less than or equal to 0.1 % of the minimum totalized load. Yes  No  N/A
- 1.6 The MWT shall indicate in one or more of the weight units indicated in table T.1 check the applicable unit(s)]. Yes  No  N/A
- 1.7 The scale division shall be in increments of 1, 2, or 5 times 10k where k is an integer. Yes  No  N/A

Table T.1	
Unit	Abbreviation
_____ pounds	Lb or LB
_____ U.S. short ton	Ton or <del>T</del> tn
_____ U.S. long ton	LT
_____ Metric ton	<del>T</del> tn
_____ kilograms	kg

- 1.8 The indicated weight value must be expressed without the use of a multiplier. Yes  No  N/A
- 1.9 The MWT may have a no-flow lockout provided the lockout is limited to not more than 3 % of the rated belt loading in terms of Yes  No  N/A



weight per unit length. The no-flow lockout must be deactivated during the zero test.

- 1.9.1 During normal operation, the MWT shall advance only when the belt conveyor is in operation and under load. Yes  No  N/A
- 1.9.2 If a no-flow lockout is provided, verify that it is limited to not more than 3 % of the rated belt loading. Yes  No  N/A
- 1.9.3 It must be possible to deactivate the no-flow lockout during the zero test. Yes  No  N/A

**2. Recording Element**

- 2.1 The MWT shall incorporate or be capable of interfacing with a recording element. Yes  No  N/A
- 2.2 The value of the scale division for the recording element shall be the same as for the MWT. Yes  No  N/A
- 2.3 The recording element shall record the initial indication and the final indication of the MWT, the quantity delivered, the unit of measurement, (i.e., kilograms, tones, pounds, tons, etc.), the date and time. (see Table T.2) This information shall be recorded for each delivery. The indicated and recorded weight values must agree to the nearest scale division. Yes  No  N/A
- 2.4 All weight values shall be recorded as digital values. Yes  No  N/A
- 2.5 Information required on the ticket: Yes  No  N/A

Table T.2	
Date	05 06 2008
Time	15:30
Master Start Total	44113.5 <del>1tn</del>
Master Stop Total	44300.5 <del>1tn</del>
Quantity	187.0 <del>1tn</del>

- 2.6 If a reset to zero mechanism is incorporated, there must be an interlock to prevent the zeroing of the device between the printing of the initial and final values of the totalized weight. Yes  No  N/A
- 2.7 The printing of weight values shall be inhibited when the flow rate is greater than either:
  - 2.7.1 3 % of the maximum flow rate, or Yes  No  N/A
  - 2.7.2 The flow rate at which the MWT is engaged unless the weight value is identified as a subtotal, in process weight, or the equivalent. Yes  No  N/A
- 2.8 The recorded weight value must be expressed without the use of a multiplier. Yes  No  N/A
- 2.9 The printer must automatically sequence through a print cycle so that each printed document includes two weight values to represent the initial and final values. Yes  No  N/A

### 3. Rate of Flow Indicator and Recorder

A rate of flow indicator and recorder are required. The MWT shall incorporate or be capable of interfacing with a rate of flow indicator and recorder. They may express the rate in weight units per hour or as a percent of capacity. The indicator and recorder may be either analog or digital.

- 3.1 The system must have both a rate of flow indicator and rate of flow recorder. Yes  No  N/A   
The rate of flow recorder is:  
\_\_\_\_\_ analog  
\_\_\_\_\_ digital
- 3.2 If a digital flow rate recorder is provided, the readings must be taken at time intervals not exceeding 10 seconds. Yes  No  N/A
- 3.3 The rate of flow indicator must indicate from zero to at least 100 % of capacity. Yes  No  N/A
- 3.4 The rate of flow recorder shall record from zero to at least 100 % of capacity. Yes  No  N/A

### 4. Rate of Flow Alarms

The system shall be equipped with a permanent means to provide an audio or visual alarm (signal) when the rate of flow is equal to or less than 20 % and equal to or greater than 100 % of the rated capacity of the scale. The alarm shall be located such that it will be noticed by the operator during normal operation.

The rate of flow alarm is:

- \_\_\_\_\_ both audio and visual      \_\_\_\_\_ audio      \_\_\_\_\_ visual
- 4.1 The alarm (signal) is located so it will be noticed during normal scale operation. Yes  No  N/A
- 4.2 Record the values at which the alarm is triggered:  
Low alarm: \_\_\_\_\_  
High alarm: \_\_\_\_\_
- 4.2.1 Is the alarm triggered when the rate of flow is equal to or less than 20 % and equal to or greater than 100 % of the rated capacity of the scale? Yes  No  N/A
- 4.3 Access to the parameters for setting the alarm limits shall be through a security means. Yes  No  N/A

### 5. Zero-Setting Mechanism

The zero-setting mechanism may be either a manual or automatic mechanism. If the zero-load reference is recorded at the beginning and end of a delivery, the range of the zero-setting mechanism shall not be greater than  $\pm 5$  % of the rated capacity of the scale. Where the zero-load reference is not recorded at

the beginning and end of a delivery, the range of the zero-setting mechanism shall be limited to  $\pm 2\%$  of the rated capacity of the scale. If a greater adjustment is needed, the access to the adjustment must be through some security means. An audio or visual signal shall be given when the automatic and semi-automatic zero-setting mechanisms reach the limit of adjustment. The zero-setting mechanism must be constructed such that the zero-setting operation is done only after a whole number of belt revolutions (a minimum of three minutes). The completion of the zero-setting operation must be indicated. The low-flow lockout must be deactivated for this test.

- 5.1 To verify the  $\pm 5\%$  range of the zero setting mechanism and the zero load reference recording capability:
- 5.1.1 Verify that the zero-setting range is limited to  $\pm 5\%$ . Yes  No  N/A
  - 5.1.2 Adjust the load simulating device to represent  $8\%$  of the scale capacity. Yes  No  N/A
  - 5.1.3 Zero the scale. Yes  No  N/A
  - 5.1.4 Adjust the load simulating device representative of a  $1\%$  of scale capacity decrease; the automatic-zero-setting mechanism shall reset the zero of the scale and the recording element shall indicate the change in zero.. Adjust for another  $1\%$  of scale capacity decrease. Again, the MWT shall reset the zero and the recording element shall indicate the change. Continue to decrease the load simulating device in  $1\%$  increments until the automatic-zero-setting mechanism no longer resets the zero. Record the total amount of adjustment. Return the load simulating device to the value initial zero value. Increase the load simulating device in  $1\%$  increments, verifying zero corrections and recordings until the MWT will no longer automatically reset the zero. Record the value where automatic zero correction is restricted. The total range of the automatic-zero-setting mechanism shall not exceed  $10\%$  of the scale capacity. Yes  No  N/A
  - 5.1.5 The zero should move a maximum of  $\pm 5\%$  either in its Automatic-zero setting mode or as manually adjusted. Yes  No  N/A
- 5.2 To verify the  $\pm 2\%$  range of the zero setting mechanism:
- 5.2.1 Verify that the zero-setting range is limited to  $\pm 2\%$ . Yes  No  N/A
  - 5.2.2 Adjust the load simulating device to represent  $5\%$  of the scale capacity. Yes  No  N/A
  - 5.2.3 Zero the scale. Yes  No  N/A

- 5.2.4 Adjust the load simulating device representative of a 1 % of scale capacity decrease; the automatic-zero-setting mechanism shall reset the zero of the scale. Adjust for another 1 % of scale capacity decrease. Again, the MWT shall reset the zero. Continue to decrease the load simulating device in 1 % increments until the automatic-zero-setting mechanism no longer resets the zero. Record the total amount of adjustment. Return the load simulating device to the value initial zero value. Increase the load simulating device in 1 % increments, verifying zero corrections, until the MWT will no longer automatically reset the zero. Record the value where automatic zero correction is restricted. The total range of the automatic-zero-setting mechanism shall not exceed 4 % the scale capacity. Yes  No  N/A
- 5.2.5 The zero should move a maximum of ± 2 % either in its Automatic-zero setting mode or as manually adjusted Yes  No  N/A
- 5.3 The zero-setting operation shall be performed only after a whole number of belt revolutions and at least three minutes of operation. Yes  No  N/A
- 5.4 The completion of the automatic zero-setting operation must be indicated. Yes  No  N/A
- 5.5 The range of the zero-setting mechanism must be limited to ± 2 % or ± 5 % of the capacity of the scale without breaking a security means. Yes  No  N/A
- 5.6 An audio or visual signal shall be given when the automatic and semi-automatic Zero-setting mechanisms reach the limit of adjustment. Yes  No  N/A
- 5.7 A belt-conveyor scale shall be equipped with a zero-ready indicator that produces an audio or visual signal when the zero balance is within ± 0.12 % of the rated capacity of the scale during an unloaded belt condition. Yes  No  N/A

**6. Sensitivity at Zero Load**

The purpose of this requirement is to assure that the MWT has sufficient resolution and sensitivity to establish a good zero reference value. The manufacturer may specify an alternate test procedure to demonstrate the required sensitivity. The no-flow lockout must be deactivated for this test.

- 6.1 Adjust the load simulating device to represent the weight required to determine compliance based on the equation:

$$\frac{2 * W_C}{C_m}$$

Example:  $\frac{2 * 500 \text{ lb}}{1000} = 1 \text{ lb}$

Where:  $C_m$  = counts in dynamic weighing scale divisions required for the minimum totalized load

$W_C$  = weight required to reach the static scale capacity of the weighbridge.

Static scale capacity = (maximum weight/foot)(length of weighbridge)

6.2 Operate the scale for a time equal to the time required to deliver the minimum totalized load.

6.2.1 Record the time period: \_\_\_\_\_ minutes.

6.3 The totalizer shall advance at least one but not more than three divisions.

6.3.1 Record the quantity registered: \_\_\_\_\_ divisions.

6.4 The MWT has the sensitivity specified at zero. Yes  No  N/A

## 7. Marking Requirements

The marking of the MWT shall meet the requirements established during the initial CC evaluation.

## 8. Provisions for Metrological Sealing of Adjustable Components or Audit Trail

Due to the ease of adjusting the accuracy of electronic Master Weight Totalizers, all MWT's must provide for a security seal that must be broken or provide an audit trail, before any adjustment that detrimentally affects the performance of the electronic device can be made. Only metrological parameters that can affect the measurement features that have a significant potential for fraud and features or parameters whose range extends beyond that appropriate for the device compliance with Handbook 44 or the suitability of equipment, shall be sealed.

For additional information on the proper design and operation of the different forms of audit trail, see the Appendix for Audit Trail.

8.1 The device has the capability for a physical seal. Yes  No  N/A

8.2 The device meets the requirements for Audit Trail. Yes  No  N/A

## 9. RFI/EMI Environment

The equipment shall be suitable for the environment in which it is intended to be used, including resistance to electromagnetic and radio-frequency interference generated by electromechanical equipment, portable hand-held radio transmitters and citizen's band transmitting equipment (if normally used at the site of installation).

9.1 The instrument meets standard NTEP RFI/EMI influence requirements. Yes  No  N/A

## 10. Laboratory Test Procedures

### Technical Policy

The MWT is to be placed in the environmental chamber to determine performance with respect to influence factors. It is not necessary to re-rest a previously type approved weighbridges, speed sensors or ancillary devices. It is not necessary, nor recommended, that signal simulators for load and speed be located in the chamber. The simulated test loads to be used for the MWT evaluation shall be equal to the signal levels from the actual tests loads used during the initial type evaluation.

### Initial Tests

1. Determine and record the load simulating device setting for zero and full scale ranges.
2. Calibrate the MWT at 20 °C.
3. Conduct the sensitivity test at zero load.
4. Verify that the range of the automatic zero setting mechanism(s) do not exceed  $\pm 2\%$  and  $\pm 5\%$  of capacity.
5. Test the alarms for flow rates below 20 % and above 100 % of rated capacity.

Once the laboratory test is started, after completion of the voltage tests, neither the zero nor the span are to be adjusted. The data should be normalized for the many tests.

The laboratory tests consist of a combination of simulated dynamic tests. These tests require adjusting a load simulating device and a speed simulating device to pre-calculated values and conducting a simulation of belt travel distances, integrating the weight on the MWT.

### Soak Requirements

The laboratory test is to be run at 20 °C, the upper temperature limit and the lower temperature limit. The surface temperature of the MWT is to be measured. In consultation with the manufacturer, place the temperature sensor on the portion of the MWT that is expected to be the last part to reach thermal equilibrium. After the surface temperature has reached the test temperature, allow the equipment to soak for at least an additional two hours, but not more than six hours, before starting the test. For convenience of the test, however, an overnight period may be used for the soak period before running the next temperature test.

1. Stabilize the temperature at 20 °C.
2. Enable the speed simulating device for a constant signal level.
3. Deactivate the automatic zero setting mechanism and no-flow lock-out.
4. Zero the MWT.

The MWT shall have sufficient resolution (that is a sufficiently small dynamic scale division) to permit this test to be completed in the greater of 20 minutes, or for a time equivalent to the test time required for the test run at 35 % of the minimum static capacity.

The beginning and ending MWT indications shall not change more than  $\pm 1$  scale division.

### Voltage Tests

(Verify the line)

1. Run an accuracy test at 98 % of scale capacity for the time to deliver 800d.
2. power source, AC or DC, is set to the manufacturers recommended nominal value (i.e., 120 VAC or 24 VDC Reduce the line power supply to 85 % of nominal (i.e., 100 VAC or 20.4 VDC).
3. Run a zero test.
4. Run an accuracy test at 98 % of scale capacity for the time to deliver 800d.
5. Increase the line power supply to 110 % of nominal (i.e., 130 VAC or 26.4 VDC).
6. Run a zero test.
7. Run an accuracy test at 98 % of scale capacity for the time to deliver 800d.

- Return the line power supply to the nominal value.

**Temperature Tests**

- Run a zero test
- Do not reset zero or adjust the span at any time after the start of this test.
- Adjust the load simulating device to achieve the desired load representations.
- Test the MWT simulating dynamic operation of the belt conveyor scale system at the following “flow rates” (all percent values represent percent loads of static scale capacity (SSC)):

0 (zero test), 35 % (SSC<sub>min</sub>), 3 %, 70 %, 98 %,

Leave the MWT under simulated load for 1 hour, then:

98 %, 70 %, 35 %, 35 % (SSC<sub>min</sub>), and 0 (zero test)

Table T.3		
Percent of Static Scale Capacity	Nominal Time (Minutes)	Equivalent Belt Travel
0	20 minutes, or $MTL_{min}/[(0.35)(BL_{min})(\text{belt speed for test})]$ , whichever is greater	_____
35 % of SSC <sub>min</sub>	20 minutes, or $MTL_{min}/[(0.35)(BL_{min})(\text{belt speed for test})]$ , whichever is greater	_____
35 % of SSC <sub>max</sub>	Time to deliver 800d	
70 % of SSC <sub>max</sub>	Time to deliver 800d	
98 % of SSC <sub>max</sub>	Time to deliver 800d	
Leave MWT under simulated load for 1 hour		
98 % of SSC <sub>max</sub>	Time to deliver 800d	
70 % of SSC <sub>max</sub>	Time to deliver 800d	
35 % of SSC <sub>max</sub>	Time to deliver 800d	
35 % of SSC <sub>min</sub>	20 minutes, or $MTL_{min}/[(0.35)(BL_{min})(\text{belt speed for test})]$ , whichever is greater	_____
0	20 minutes, or $MTL_{min}/[(0.35)(BL_{min})(\text{belt speed for test})]$ , whichever is greater	_____

The tolerance to be applied for the laboratory test is set at 0.45 times the tolerance for the complete installation times 0.3 (30 %). The formula is shown in Table T.4 to illustrate the process. The reference value for a particular accuracy test is the simulated load times the simulated belt travel distance. The values to be used for the laboratory test are shown in the following example:

**98 % load – Zero load test = difference**

Proportion the effect of the zero-load test to the time of the tests for each simulated load. The values for the differences represent the simulated material measured by the MWT and is compared to the reference value for accuracy.

1. Change the temperature to – 10 °C (14 °F) at a rate no faster than 1° C/min following the “soak requirements”.
2. Repeat the simulated dynamic tests.
3. Change the temperature to 40 °C (104 °F) at a rate no faster than 1 °C/min following the “soak requirements”.
4. Repeat the simulated dynamic tests.
5. Change the temperature to 20 °C (68 °F) at a rate no faster than 1 °C/min following the “soak requirements”.
6. Repeat the simulated dynamic tests.

#### Data Analysis

1. The data are evaluated on the Simulated Dynamic MWT Test Work Sheet, Items 14 and 15, for pass or fail.

#### 11. Field Test

A field test is required prior to final type approval. The field test ~~can~~ **must** be performed as a retrofit on a previously approved for commercial use belt-conveyor scale system or in a new application. The Field Test Procedures as defined in ~~paragraph 13 of the initial belt-conveyor scale Type Evaluation section of Publication 14 and Sections N.2, N.3.1., and N.3.2. of~~ NIST Handbook 44 are to be followed. The results of all tests must be within acceptance tolerances.

#### 12. Permanence Test

**Since this policy is intended for use only during the evaluation of master weight totalizers and not for the material handling system in which they will be installed, there is no field permanence test required. Permanence testing on the MWT instrument will take place during laboratory evaluations listed under Section E in this document.**

~~A permanence test is conducted to determine the accuracy of the device in use over a period of time. The permanence test shall be conducted after a minimum of 20 days after successful completion of the initial performance test, and after a minimum volume of material has been transported across the belt-conveyor scale. This minimum volume of material shall be no less than the maximum scale capacity times 8 hours times 20 days. (i.e., A system with a maximum scale capacity of 1000 TPH requires a minimum volume of 160,000 tons [1000 \* 8 \* 20] to have been transported prior to the permanence test.) The results of all tests must be within acceptance tolerances.~~

**The permanence test shall include:**

- ~~Initial stable zero tests~~
- ~~at least two test loads at normal use capacity~~
- ~~simulated load tests~~
- ~~verification of audit trail recorded events~~

#### 13. Data Sheet and Lab Test Procedure

Temperature Testing: Belt-Conveyor Scale Code paragraphs T.3.1., T.3.1.1., T.3.1.2. The accuracy of the MWT is to be adjusted at 70 % of the static scale capacity (SSC). A weight display of 0.01 % (1 part in 10 000) is required for the laboratory tests. The allowable error is adjusted to 30 % of the allowable error for the entire system type approval. If tests are run for a time greater than that needed for the



minimum test load (MTL), substitute the totalized load (TL) for the MTL in the tolerance calculation in Test Conditions, step 3 (Table T.4)

This publication is available free of charge from: <https://doi.org/10.6028/NIST.SP.1210>

<b>Table T.4</b>				
<b>Device Parameters</b>	<b>Abbrev.</b>	<b>Maximum</b>	<b>Minimum</b>	<b>Dim</b>
1. Load per unit length from existing Certificate of Conformance; corresponds to the largest capacity and the lowest capacity rating	BL			lb/ft
2. Length of the weighbridge (inches) from existing Certificate of Conformance				In
3. Belt Speed from existing Certificate of Conformance	SP			ft/min
4. Determine scale capacity in units per hour $SC = SP * BL * 60 / 2000$ (must correspond to existing Certificate of Conformance)	SC			ton/hr
5. Record the static scale capacity in units of weight $SSC = (\text{maximum weight per foot}) * (\text{length of weighbridge})$	SSC			lb
6. Allowable zero error for temperature change of 10 °C (18 °F) $AZE = \mathbf{(-0.03)(0.3)}(0.0007)(SC_{\min})(\text{time})/60$ where "time" is the time of the zero test in minutes	AZE			ton
7. Size of scale division required for zero	SD			ton
8. Determine the minimum and maximum totalized loads	MTL			ton
<b>Test Conditions</b>		<b>Abbrev.</b>		<b>Dim</b>
1. Determine the time n minutes to acquire MTL with the test load to be simulated in the laboratory	Test load, pound/foot			lb/ft
	Test load, total			lb
	Time (minutes) to deliver MTL (at least 10 minutes)	Time		min
2. Determine number of belt travel sensor revolutions required for the above time. Manufacturer to provide revolutions per foot or pulses per foot as appropriate to determine three belt revolutions and a delivery of 800d.		BTR		revolutions

3. Allowable weighing error (units of weight) for simulated dynamic tests which will be divisions on master weight totalizer. $AWE = \cancel{(0.003)}(0.30)(0.45)(0.005)(TL)$	AWE			ton
--	-----	--	--	-----

<b>Table T.5</b>
<b>Initial Tests</b>
1. Set up the unit at 20 °C (68 °F), zero the MWT and adjust the span following the manufacturer’s procedure.
2. Conduct the sensitivity test at zero load.
3. Verify that the range of the automatic zero setting mechanism(s) do not exceed ± 2 % and ± 5 % of capacity.
4. Test the alarms for flow rates below 20 % and over 100 % of scale capacity.

<b>Table T.6</b>
<b>Laboratory Tests</b>
1. Stabilize the temperature at 20 °C
2. Enable the speed simulator to represent 100 % speed
3. Deactivate the automatic zero setting mechanism and zero the MWT
4. Run a zero test
<b>Voltage tests</b>
5. Run an accuracy test at 98 % of scale capacity for the time to deliver 800d
6. Reduce the live voltage to 85 % of nominal
7. Run a zero test
8. Run an accuracy test at 98 % of scale capacity for the time to deliver 800d
9. Increase the line voltage to 110 % of nominal
10. Run a zero test
11. Run an accuracy test at 98 % of scale capacity for the time to deliver 800d
12. Return the live supply to nominal
<b>Temperature Tests</b>
13. Run a zero test. Do not reset zero or adjust the span at any time after the start of this test.
14. Adjust the load simulating device to represent normal loading of the scale (70 % of scale capacity)

This publication is available free of charge from: <https://doi.org/10.6028/NIST.SP.1210>

15. At 20 °C, test the MWT dynamically with simulation of the load and speed. Test the MWT at the following “flow rates” (all percent values represent percent loads of static scale capacity): 0 (zero test), 35 % (SSC<sub>min</sub>), 35 %, 70 %, 98 %, leave the MWT at full load for one hour, 98 %, 70 %, 35 %, 35 % (SSC<sub>min</sub>), and 0 (zero test)

**Table T.7**

Percent of Static Scale Capacity	Time (Minutes)	Totalized Load TL (ton)	Tolerance AWE= <del>(0.003)</del> (0.30)(0.45)(0.005)(TL)
0	20 minutes, or $MTL_{min}/[(0.35)(BL_{min})(\text{belt speed for test})]$ , whichever is greater		
35 % of SSC <sub>min</sub>	20 minutes, or $MTL_{min}/[(0.35)(BL_{min})(\text{belt speed for test})]$ , whichever is greater		
35 % of SSC <sub>max</sub>	Time to deliver 800d		
70 % of SSC <sub>max</sub>	Time to deliver 800d		
98 % of SSC <sub>max</sub>	Time to deliver 800d		
<i>Leave MWT under simulated load for 1 hour</i>			
98 % of SSC <sub>max</sub>	Time to deliver 800d		
70 % of SSC <sub>max</sub>	Time to deliver 800d		
35 % of SSC <sub>max</sub>	Time to deliver 800d		
35 % of SSC <sub>min</sub>	20 minutes, or $MTL_{min}/[(0.35)(BL_{min})(\text{belt speed for test})]$ , whichever is greater		
0	20 minutes, or $MTL_{min}/[(0.35)(BL_{min})(\text{belt speed for test})]$ , whichever is greater		

**Table T.8**

**Laboratory Tests (continued)**

16. Change the temperature to – 10 °C (14 °F) at a rate no faster than 1 °C/min. Follow soak requirements.
17. Repeat the simulated dynamic tests performed in step 15 (Table T.6)
18. Change the temperature to 40 °C (104 °F) at a rate no faster than 1 °C/min. Follow soak requirements.
19. Repeat the simulated dynamic tests performed in step 15 (Table T.6)
20. Change the temperature to 20 °C (68 °F) at a rate no faster than 1 °C/min. Follow soak requirements
21. Repeat the simulated dynamic tests performed in step 15 (Table T.6)

<b>Data Analysis</b>
1. The data are evaluated on the following Simulated Dynamic MWT Test Work Sheets for pass or fail
2. Approval is for addition of MWT to existing Certificate of Conformance without changes to minimum and maximum ranges.

**14. Dynamic MWT Test Work Sheet and Laboratory Test Procedure No. 1**

The calibration point is the 70 % load for the initial room temperature (20 °C) test. Because the weight indication when in the test mode may not be at zero and may not be adjusted to indicate n weight values (e.g., the quantity indication may be voltage output or “counts”, the table provides for calculations to convert indications into weight units). The scale indication shall not be zeroed during the test process. Corrections for the change in zero tests are to be done by calculation.

Places to record information needed for the test and the formulae needed to compute table entries are given below.

Static Scale Capacity, SSC = (maximum weight per foot)(length of weighbridge) = \_\_\_\_\_ lb.

Test load for 70 % percent SSC = \_\_\_\_\_ lb.

Weight/foot = (static scale load)/(length of weighbridge) = Static scale capacity)/(length of weighbridge)

Start and end readings are in divisions and must be converted to weight values.

Conversion factor for divisions to weight = (change in static weight indication from zero to 70 % SSC load)/(70 % SSC load in pounds)

Change in zero = (Total change of zero during zero test( {(time of test for applied load)/(time of zero test)})

Indication corrected for change of zero = (Indicated change) – (Change of zero)

Scale indication in lb = (Indication corrected for change of zero) / (Conversion factor)

Actual weight = {(Applied load)/(length of weighbridge)}(speed)(time)

**Note:** Speed and time must use the same units of time (e.g., feet per minute and minutes)

Error = Scale indication – actual weight

Tolerance is from the Belt-Conveyor Scale Data Sheet and Laboratory Test Procedure, step 3.

**15. Dynamic MWT Test Work Sheet and Laboratory Test Procedure No. 2**

Scale indication at zero load (static scale indication) = \_\_\_\_\_ divisions

(Not required if MWT can display static weight)

Scale indication at 70 % SSC (static scale indication) = \_\_\_\_\_ divisions

(Not required if MWT can display static weight)

This publication is available free of charge from: <https://doi.org/10.6028/NIST.SP.1210>

NTEP Committee 2015 Final Report  
 Appendix B – NTEP 2014 Belt-Conveyor Scale Sector Meeting Summary

Conversion factor = (change in static weight indication from zero to 70 % SSC load)/(70 % AAC load in pounds) = divisions/lb

Temperature \_\_\_\_\_ °C Type of Tests \_\_\_\_\_ Signature \_\_\_\_\_

**Table T.9**

Test Load (lb)	Applied load (lb)	Time of test in minutes	Reading in counts		Indicated Change = End - Start	Change in Zero	Indication corrected for change in zero	Scale Indication (lb)	Actual Weight	Error (lb)	Tolerance (lb)
			End	Start							
Zero test	0										
35 % SSC <sub>min</sub>											
35 % SSC <sub>max</sub>											
70 % SSC <sub>max</sub>											
98 % SSC <sub>max</sub>											
Leave scale under simulated load for 1 hour											
98 % SSC <sub>max</sub>											
70 % SSC <sub>max</sub>											
35 % SSC <sub>max</sub>											
35 % SSC <sub>min</sub>											
Zero test	0										

This publication is available free of charge from: <https://doi.org/10.6028/NIST.SP.1210>

16. Zero Change with Respect to Temperature

Table T.10							
	Low Temperature		High Temperature		20 °C		Performance limit for temperature effect on zero test, AZE, per 10 °C
Previous Temperature $T_P$	20 °C						
Current Temperature $T_C$					20 °C		
Change in Temperature ( $T_C - T_P$ )							
	Divisions	lb	Divisions	lb	Divisions	lb	
Zero load indication at $T_P$							
Zero load indication at $T_C$							
Change in zero							
Change in zero per 5 °C (9 °F)							

Date: \_\_\_\_\_

Indicator Model Number: \_\_\_\_\_ Indicator Serial Number: \_\_\_\_\_

\_\_\_\_\_  
 Signature

\_\_\_\_\_  
 Title

This publication is available free of charge from: <https://doi.org/10.6028/NIST.SP.1210>

THIS PAGE INTENTIONALLY LEFT BLANK

## Appendix C

# National Type Evaluation Program (NTEP) Grain Analyzer Sector Summary

August 20 - 21, 2014  
Kansas City, Missouri

### INTRODUCTION

The charge of the Grain Analyzer Sector is important in providing appropriate type evaluation criteria based on NIST Handbook 44, “Specifications, Tolerances, and Other Technical Requirements for Weighing and Measuring Devices,” Sections 1.10. General Code, 5.56.(a) and 5.56.(b) Grain Moisture Meters, and 5.57. Near-Infrared Grain Analyzers. The Sector’s recommendations are presented to the National Type Evaluation Program (NTEP) Committee each January for approval and inclusion in *NCWM Publication 14 Technical Policy, Checklists, and Test Procedures* for national type evaluation.

The Sector is also called upon occasionally for technical expertise in addressing difficult NIST Handbook 44 issues on the agenda of National Conference on Weights and Measures (NCWM) Specifications and Tolerances (S&T) Committee. Sector membership includes industry, NTEP laboratory representatives, technical advisors, and the NTEP Administrator. Meetings are held annually, or as needed and are open to all NCWM members and other registered parties.

Proposed revisions to the handbook(s) are shown as follows: 1) deleted language is indicated with a **bold face font using strikeouts** (e.g., ~~this report~~), 2) proposed new language is indicated with an **underscored bold faced font** (e.g., new items), and 3) nonretroactive items are identified in *italics*. There are instances where the Sector will use **red** text and/or **highlighted** text to bring emphasis to text that requires additional attention. When used in this report, the term “weight” means “mass.”

**Note:** It is the policy of the National Institute of Standards and Technology (NIST) to use metric units of measurement in all of its publications; however, recommendations received by NCWM technical committees and regional weights and measures associations have been printed in this publication as submitted. Therefore, the report may contain references in U.S. customary units.

---

**Table A**  
**Table of Contents**

---

<b>Title of Content</b>	<b>Page</b>
<b>INTRODUCTION</b> .....	<b>1</b>
1. Selecting a new NTETC Grain Analyzer (GA) Chairperson.....	3
2. Report on the 2013 NCWM Interim and Annual Meetings.....	3
3. Report on NTEP Evaluations and Ongoing Calibration Program (OCP) (Phase II) Testing .....	3
4. Review of OCP (Phase II) Performance Data.....	4
5. Modify the Definition of Remote Configuration Capability Appearing in Appendix D of NIST Handbook 44 to Recognize the Expanded Scope of “Remote Configuration Capability” (S&T Developing item 360-7) .....	4
6. Status of Interagency Agreement .....	8
7. Test Weight per Bushel Acceptance and Maintenance Tolerance .....	15



8.	Report on International Organization of Legal Metrology (OIML) TC 17/SC 1 R 59 <i>Moisture Meters for Cereal Grains and Oilseeds</i> .....	18
9.	Report on OIML TC 17/SC 8 <i>Protein Measuring Instruments for Cereal Grain and Oil Seeds</i> .....	19
10.	Software Sector Items .....	20
11.	Update on Proficiency Testing .....	30
12.	The Feasibility of a Phase II program for Near Infrared Grain Analyzers .....	32
13.	Next Sector Meeting .....	32

**Table B**  
**Glossary of Acronyms and Terms**

<b>Acronym</b>	<b>Term</b>	<b>Acronym</b>	<b>Term</b>
BIML	International Bureau of Legal Metrology	NTETC	National Type Evaluation Technical Committee
CD	Committee Draft	OCP	Ongoing Calibration Program
CIML	International Committee of Legal Metrology	OIML	International Organization of Legal Metrology
CIPM	International Committee of Weights and Measures	OWM	Office of Weights and Measures
D	Document	R	Recommendation
EMRP	European Metrology Research Program	S&T	Specifications and Tolerances
FGIS	Federal Grain Inspection Service	SC	Subcommittee
GA	Grain Analyzer	SD	Secure Digital
GIPSA	Grain Inspection, Packers and Stockyards Administration	TC	Technical Committee
GMM	Grain Moisture Meter	TW	Test Weight
MRA	Mutual Recognition Agreement	UGMA	Unified Grain Moisture Algorithm
NCWM	National Conference on Weights and Measures	USB	Universal Serial Bus
NIR	Near Infrared Grain Analyzer	USDA	U. S. Department of Agriculture
NIST	National Institute of Standards and Technology	USNWG	U.S. National Working Group
NTEP	National Type Evaluation Program		

---

**Details of All Items**  
*(In order by Reference Key)*

---

**1. Selecting a new NTETC Grain Analyzer (GA) Chairperson**

Ms. Cassie Eigenmann, the NTETC GA Chair, notified the GA Sector on January 24, 2014, that she was retiring from her position as Analytical Laboratory Manager at the DICKEY-john Corporation effective February 4, 2014, and, therefore, would resign from her position as Chair of the NTETC GA Sector. In her January 24, 2014, e-mail notification, Ms. Eigenmann also informed the GA Sector that NCWM requested she poll the Sector members for possible candidates to fill the NTETC GA Chair position. One nomination for Sector Chairperson was received for Mr. Karl Cunningham of Illinois Weights and Measures. Additional nominations may be made during the meeting.

Ms. Eigenmann held the position of NTETC GA Sector Chair for over 10 years. Her facilitation of the Sector discussions over the years has helped the Sector with numerous proposals and recommendations for changes to NCWM Publications 14 and NIST Handbook 44. We wish her well in her future endeavors.

In accordance with the NTEP Administrative policies, there is no fixed term for the NTETC GA Chair position. The Sector Chair must be a member of NCWM, and the Sector Chair is appointed by the NTEP Committee Chair.

A new GA Sector Chair will be selected at the August 2014 NTETC Sector Meeting.

Ms. Eigenmann attended the August 2014 NTETC meeting and performed the duties of the Sector Chairman. Ms. Eigenmann informed the Sector that after polling the Sector she received one nomination, Mr. Karl Cunningham of Illinois, for the position of the Grain Analyzer Sector Chair. A question was raised as to whether or not travel would be a concern for Mr. Cunningham. Mr. Cunningham responded that travel would not be a concern. Ms. Eigenmann asked if there were any additional nominations. No additional nominations were made and the Sector voted unanimously for Mr. Cunningham as the new Grain Analyzer Sector Chairman.

**2. Report on the 2013 NCWM Interim and Annual Meetings**

The 2014 NCWM Interim Meeting was held January 19 - 22 in Albuquerque, New Mexico. At the meeting, no recommended amendments to Publication 14 for grain analyzers were provided to the NTEP Committee.

The 2014 NCWM Annual Meeting was held July 13 - 17, 2014, in Detroit, Michigan. There were no Grain Analyzer Sector Voting Items on the agenda. There was one Grain Analyzer Sector Developing item on the S&T agenda, **Item 360-7, Appendix D – Definitions: Remote Configuration Capability**. See Grain Analyzer Agenda Item 5, below, for details.

Mr. Jim Truex, NTEP Administrator, provided an update on the Interim and Annual Meetings. He reported that there was good representation at the 2014 Interim and Annual Meetings compared to other years, and the NTEP Committee accepted the Grain Analyzer Sector's recommended changes to NCWM Publication 14 as reported in the 2013 Grain Analyzer Sector Summary.

**3. Report on NTEP Evaluations and Ongoing Calibration Program (OCP) (Phase II) Testing**

Ms. Cathy Brenner and Mr. Rick Dempster, Grain Inspection, Packers and Stockyards Administration (GIPSA), the NTEP Participating Laboratory for grain analyzers, brought the Sector up-to-date on NTEP Evaluation (Phase I) activity. They also reported on the collection and analysis of Grain Moisture Meter OCP (Phase II) data on the 2013 crop and identified the models enrolled in Phase II for the 2014 harvest. For the 2014 harvest, seven models are enrolled in Phase II this year. The manufacturers will be charged on the basis of six models because, by using GAC2500-UGMA data, DICKEY-john can automatically back calculate calibrations to the GAC2500 without having to run samples on the GAC2500\*.

The seven models:

1. Bruins Instruments – OmegAnalyzerG
2. DICKEY-john Corp. – GAC2000 (NTEP Version), GAC2100a and GAC2100b2100
3. DICKEY-john Corp. – GAC2500 (\*See note above. Will not run samples on this model. )
4. DICKEY-john Corp. – GAC2500-UGMA
5. Foss North America – Infratec 1241
6. Perten Instruments Inc. – 9500, AM5200 and AM5200-A (The AM5200-A is UGMA Certified.)
7. The Steinlite Corporation – SL95

#### 4. Review of OCP (Phase II) Performance Data

At the Sector’s August 2015 meeting, it was agreed that comparative OCP data identifying the Official Meter and listing the average bias for each NTEP meter type should be available for annual review by the Sector. Accordingly, Ms. Brenner, GIPSA, the NTEP Participating Laboratory for Grain analyzers presented data showing the performance of NTEP meters compared to the air oven. This data is based on the last three crop years (2011 - 2013) using calibrations updated for use during the 2014 harvest season. The 2011 - 2013 Grain Moisture Meter (GMM) Phase II comparison graphs are available for view or can be downloaded for printing at the following web address:

[http://www.ncwm.net/resources/dyn/files/1235447z287194bf/\\_fn/GMMBiases14.pdf](http://www.ncwm.net/resources/dyn/files/1235447z287194bf/_fn/GMMBiases14.pdf)

At the August 2014 Grain Analyzer Sector meeting, the NTEP laboratory reported the following information concerning the 15 NTEP grains for the 2013 crop year:

- The grains collected were from late harvested grains.
- Due to the government shut down, sample maintenance was performed during the current year.

#### 5. Modify the Definition of Remote Configuration Capability Appearing in Appendix D of NIST Handbook 44 to Recognize the Expanded Scope of “Remote Configuration Capability” (S&T Developing Item 360-7)

**Source:**

NTETC Grain Analyzer Sector

**Purpose:**

*Table S.2.5. Categories of Device and Methods of Sealing* that appears in §5.56.(a) of NIST Handbook 44 lists acceptable methods of sealing for various categories of GMMs. When the Sector first recommended adding the table to NIST Handbook 44 at their September 1996 meeting, the concept of making a change to a GMM from a remote site involved information “...sent by to the device by modem (or computer).” In 2011 this concept has expanded to include the ability of the measuring device to accept new or revised sealable parameters from a memory chip (e.g., an SD Memory Card that may or may not itself be necessary to the operation of the device), external computer, network, or other device plugged into a mating port (e.g., Universal Serial Bus (USB) port) on the measuring device or connected wirelessly to the measuring device. The changes proposed in Item under Consideration expand the scope of “remote configuration capability” to cover instances where the “other device” may be necessary to the operation of the weighing or measuring device or which may be considered a permanent part of that device.

**Item under Consideration:**

**remote configuration capability.** – The ability to adjust a weighing or measuring device or change its sealable parameters from or through some other device that ~~is not~~ may or may not itself ~~be~~ necessary to the operation of the weighing or measuring device or ~~is not~~ may or may not be a permanent part of that device.[2.20, 2.21, 2.24, 3.30, 3.37, 5.56(a)]

(Added 1993, Amended 20XX)

**Background/Discussion:**

Two common types of removable data storage devices are the USB flash drive and the Secure Digital (SD) memory card. A USB flash drive is a data storage device that includes flash memory with an integrated USB interface. USB flash drives are typically removable, rewritable, and physically much smaller than a floppy disk. A SD card is a non-volatile memory card format originally designed for use in portable devices. The SD standard is maintained by the SD Card Association.

Removable digital storage devices can be used in GMMs as either “data transfer” devices, which are not necessary to the operation of the GMM, or as “data storage devices,” which are necessary to the operation of the GMM.

A USB flash drive is most likely to be used as a “data transfer” device. In a typical “data transfer” application, the USB flash drive is first connected to a computer with access to the web. The computer visits the GMM manufacturer’s web site and downloads the latest grain calibrations that are then stored in the USB flash drive. The USB flash drive is removed from the computer and plugged into a USB port on the GMM. The GMM is put into “remote configuration” mode to copy the new grain calibration data into the GMM’s internal memory. When the GMM has been returned to normal operating (measuring) mode, the USB flash drive can be removed from the GMM.

Although an SD memory card could also be used as a “data transfer device,” it is more likely to be used as a “data storage device”. In a typical “data storage device” application, the SD memory card stores the grain calibrations used on the GMM. The SD memory card must be plugged into an SD memory card connector on a GMM circuit card for the GMM to operate in measuring mode. To install new grain calibrations, the GMM must be turned “off” or put into a mode in which the SD memory card can be safely removed. The SD memory card can either be replaced with an SD memory card that has been programmed with the new grain calibrations or the original SD memory card can be re-programmed with the new grain calibrations in much the same way as that described in the preceding paragraph to copy new grain calibrations into a USB flash drive. In either case, the SD memory card containing the new calibrations must be installed in the GMM for the GMM to operate in measuring mode. In that regard, the SD memory card can be considered a “permanent part” of the GMM in that the GMM cannot operate without it.

**Note:** In the above example “SD memory card” could be any removable flash memory card such as the Secure Digital Standard-Capacity, the Secure Digital High-Capacity, the Secure Digital Extended-Capacity, and the Secure Digital Input/Output, which combines input/output functions with data storage. These come in three form factors: the original size, the “mini” size, and the “micro” size. “Memory Stick” is a removable flash memory card format, launched by Sony in 1998, and is also used in general to describe the whole family of Memory Sticks. In addition to the original Memory Stick, this family includes the Memory Stick PRO, the Memory Stick Duo, the Memory Stick PRO Duo, the Memory Stick Micro, and the Memory Stick PRO-HG.

At its 2012 meeting, the Grain Analyzer Sector agreed by consensus to accept the Item under Consideration and recommended forwarding this item to the S&T Committee for consideration.

2012 WWMA Annual Meeting: Ms. Juana Williams (NIST, OWM) supported the intent. She talked about this item in conjunction with Item 356-1, S.2.5. Categories of Device and Methods of Sealing. This is a complex item affecting multiple other devices; therefore, the proposal requires further consideration. The language in the proposal to amend the definition of remote configuration capability is confusing. The Committee believes the current definition already allows the use of remote configuration devices and allows the flexibility desired. The ramifications of changing the definition could affect other devices in NIST Handbook 44. The WWMA did not forward this item to NCWM.

2012 SWMA Annual Meeting: There were no comments. After reviewing the proposal and considering the potential impact on other device types, the Committee recommended this as a Developing item. The Committee asks that the Sector continue to obtain input on the definition and the impact the changes would have on other device types. SWMA forwarded the item to NCWM recommending it as a Developing item and assigning its development to the Grain Analyzer Sector.

NCWM 2013 Interim Meeting: During its Open Hearings at the 2013 NCWM Interim Meeting, the Committee heard comments from Ms. Juana Williams (NIST OWM). OWM suggests the Committee consider this item as a Developing item to allow other Sectors to discuss how a change to the definition may affect other device types of similar design and to consider changes if needed. OWM recognizes the current definition for “remote configuration capability” may

not address those grain moisture meters (GMMs) that can only be operated with a removable data storage device containing, among other things, the grain calibrations intended for use with the GMM inserted in the device (as was described by the Grain Analyzer Sector). As such, NIST, OWM notes that current sealing requirements were developed at a time when such technology likely didn't exist, nor could be envisioned, and are based on the current definition of remote configuration capability. Because the current definition was never intended to apply to this "next generation" technology, NIST, OWM suggests that those charged with further development of this item may wish to revisit the five philosophies of sealing and consider whether a new paragraph, completely separate from current sealing requirements, might be appropriate and a better option, than the one currently proposed. The five philosophies of sealing are included in the 1992 *Report of the 77<sup>th</sup> National Conference on Weights and Measures* (Report of the Specifications and Tolerances Committee). Another option, preferred over the changes currently proposed, would be to add a separate statement to the current definition of "remote configuration capability" to address removable storage devices. For example, the following sentence might be considered as an addition to the current definition for "remote configuration capability:"

**Devices which are programmed using removable media (such as SD cards, flash drives, etc.) that may or may not be required to remain with the device during normal operation are also considered to be remotely configured devices.**

The Committee also heard comments from Mr. Karimov (Liquid Controls), speaking on behalf of the MMA, who made two points: 1) flow computers may already have these capabilities; thus, it may be more appropriate to consider adding requirements to the General Code so the requirements will be uniformly applied to all device types; and 2) the Committee should look ahead and consider other capabilities that may or already have emerged such as wireless communication and configuration.

The Committee acknowledged the comments indicating that the current definition of "remote configuration capability" was developed at a time when certain technologies, such as blue tooth, SD storage devices, flash drives, etc., didn't exist. The Committee recognized it may be difficult to modify the existing definition and associated requirements to be flexible enough to address emerging and future technologies without having a significant (and possibly detrimental impact) on existing devices. Consequently, rather than modifying the current definition, the Committee concluded that a better approach might be to develop an entirely separate set of security requirements that would apply to emerging technologies. The Committee believes that additional work is needed to develop proposed definition(s) and associated requirements and decided to designate the item as Developmental. The Committee requests other Sectors review the Grain Sector's proposed modification to the definition as well as OWM's suggestions and provide input.

NEWMA and CWMA 2013 Annual Meetings: At their 2013 Annual Meetings, both NEWMA and CWMA supported this as a Developing item. NEWMA heard from NIST, OWM who encouraged members to consider this work as it applies to all device types.

On the 2013 NCWM Online Position Forum, one Government representative indicated a neutral position on this item with no additional comments.

NCWM 2013 Annual Meeting: At the Open Hearings, the Committee heard comments from Ms. Juana Williams (NIST, OWM) who reiterated OWM's comments from the 2013 Interim Meeting, suggesting that it may be appropriate to develop separate requirements to address new and future technologies that can be remotely configured with removable media. OWM plans to develop draft language and ask for input from the various Sectors at their upcoming meetings. Ms. Williams also noted the suggestion made at the 2013 NCWM Interim Meeting by Mr. Dmitri Karimov, Liquid Controls, speaking on behalf of the MMA, that a provision might be added to the General Code to address this type of equipment.

Ms. Julie Quinn (Minnesota) agreed with NIST, OWM's comments and indicated support for possibly including requirements in the General Code to address newer and emerging technologies. Mr. Karimov, speaking on behalf of MMA, concurred with this suggestion.

At the August 2013 Grain Analyzer Sector Meeting, NIST, OWM had not drafted a definition for remote configuration capability to address devices which are programmed using removable media such as SD cards or flash drives. During

the August 2013 Grain Analyzer Sector Meeting, the Sector discussed other ways devices can be remotely configured that should also be considered when drafting a definition for remote configuration capability to address these devices.

Mr. Hurburgh mentioned we also need to consider devices using cloud computing to remotely configure a device and suggested that we consider the various ways a device can be remotely configured.

The Sector agreed that NIST, OWM should develop a proposal for a definition for remote configuration capability that addresses devices using removable media such as SD cards, flash drives or other methods not covered by the existing definition.

At the 2013 Weighing Sector meeting, NIST, OWM requested members of the Sector help identify the various types of removable storage media (e.g., USB flash drives, SD memory cards, etc.) currently in use with weighing equipment and to describe the functionality of the media. The information provided would likely be used by NIST, OWM to develop some draft proposals to amend NIST Handbook 44 to adequately address the security of the metrological significant parameters of devices using such media.

The following feedback was provided by members of the Sector to NIST, OWM:

- I am not in favor of changing standards for advances in technology.
- Both SD cards and USB Flash drives can be used for data transfer and data storage. It would be difficult to address all devices by changing the General Code.
- There are other technologies besides SD and Flash digital storage devices that must be considered (e.g., Eprom and EEPROM, etc.).
- Several members commented that they felt it would likely be necessary to separate requirements in the various codes of NIST Handbook 44.
- It is not reasonable to expect manufacturers to share the technologies used in a public forum such as this meeting, and it might be better to speak individually with representatives of the different manufacturers.

At the end of this discussion, a few weighing Sector members offered to provide technical expertise to assist NIST, OWM in answering any questions that might arise during future development of proposed requirements to address this issue.

At the 2013 Measuring Sector Meeting, the Sector did not support the language “may or may not be necessary” because this phrase changes the category of what is considered “remote configuration capability.” The Sector agreed that if the card (or other removable device) needs to be a part of the measuring device for normal operation, then the card is effectively part of the device; in that case, the measuring device is a Category 1. If the card is only used for configuration or calibration and is not necessary for the operation of the measuring device, the measuring device is a Category 2. The Sector discussed whether or not additional guidance might be needed on what is covered by each sealing category; however, the Sector concluded that the definitions are adequate as currently written.

At the August 2014 Grain Analyzer Sector meeting, the Sector considered the responses from NIST OWM, SWMA, WWMA, Measuring Sector, and Weighing Sector concerning devices that use SD cards, flash drives, or other methods for configuration.

**Conclusion:**

The Grain Analyzer Sector agreed that the current proposed language may be confusing and agreed to Withdraw their proposal for changes to the definition of remote configuration.

## 6. Status of Interagency Agreement

### Source:

Cathy Brenner, USDA, GIPSA  
G. Diane Lee, NIST, OWM

**Background/Discussion:** The current Interagency Agreement is the fourth, five-year agreement of the ongoing Calibration Program. The agreement was signed in March 2010 and runs through the analysis of the 2014 crop and the issuance of the 2015 Certificates of Conformance (CC). Thus, we have just started the fifth year of the current agreement. It should be noted that annual calibration activities occur in two government fiscal years and are better defined by a starting date of July 1.

GIPSA noted that in order to provide the standardization services to the commercial system, GIPSA TSD discussed options for improving the process and reducing the burden on all parties. At the August 2013 Grain Analyzer Sector meeting, GIPSA sought input from the Sector on limiting the number of samples tested to a maximum of 10 samples per 2 % moisture interval for all grains. It was noted that fewer sample are needed to calibrate the new UGMA meters. It was also noted that GIPSA's fees are increasing, and with no changes to the program the manufacturers' fees will increase. During the discussion, one alternate proposal was to base the cost on shared cost of the program where GIPSA and NIST cover a third of the cost of the program each and manufacturers split a third of the cost. It was noted during the meeting that due to budget issues GIPSA and NIST will likely not be able to fund more than the 30 000 per year.

Ms. Brenner agreed to review the statistics to determine how the sample size of up to 30 samples per 2 % moisture interval per grain type was established and to investigate the impact of reducing the sample size to 10 samples per 2 % percent moisture interval per grain type. The Sector agreed by consensus to reduce the number of samples used in the ongoing calibration program for each 2 % percent moisture range per grain type as long as the integrity of the program is not affected.

A fifth, five-year Interagency Agreement has been drafted based upon GIPSA's base cost per NTEP only meters above the cost to maintain the official moisture meters. The agreement is currently being forwarded for appropriate signatures at NIST and then to GIPSA. The interagency agreement includes tables of the base cost per NTEP only meter and descriptions for funding calculations and fee tables for each year of the agreement. The fee tables are based on the reduced number of samples per 2 % percent moisture interval.

At the 2014 Grain Analyzer Sector Meeting, Ms. Cathy Brenner reported she found no statistical impact in reducing the sample size in the ongoing calibration program from up to 30 samples to 10 samples per 2 % percent interval. During the review of the ongoing calibration fee tables, Mr. Andy Gell, Foss North America, pointed out the cost per meter in the ongoing calibration program would be decreased due to the reduction in the number of samples per 2 % moisture interval. Mr. Gell then noted the tables showed an increase in the cost per meter. After further review by the Sector, an error was found in calculating the cost per meter. Corrections were made to the fee tables, and corrections to the tables are shown below:

**Table 1 Description of Program Fee Schedule Acronyms and Funding Source Calculations**

Key and/or Funding Source	Description
O	Number of GIPSA official meters
N	Number of NTEP only meters (non-GIPSA official meters)
BC	FY Base Cost per NTEP only Meters in the ongoing calibration program
TP	Total NTEP Program Cost = $N \times BC$
TM	$(O + N)$ Total Meters including Official Meters
NIST	National Institute of Standards and Technology Contribution = $TP / 3$ up to and not more than 30 000
GIPSA	Grain Inspection Packers and Stockyards Administration contribution = $TP / 3$ up to and not more than 30 000
MCMT	Manufacturers Cost per Meter Type = $TP - NIST$ contribution – GIPSA contribution

**Table 2 Ongoing Calibration Program Base Cost per NTEP only meter per Fiscal Year**

Fiscal Year (FY)	NTEP Ongoing Calibration Program Base Cost per NTEP only Meter (Above GIPSA Costs to Maintain the Official Moisture Meters)  (BC)
2015	\$17,678
2016	\$18,064
2017	\$18,453
2018	\$18,513
2019	\$18,576

This publication is available free of charge from: <https://doi.org/10.6028/NIST.SP.1210>



This publication is available free of charge from: <https://doi.org/10.6028/NIST.SP.1210>

NTEP Ongoing Calibration Program Fee Schedule for Year 2015							
(1) Total Meters (including official meter) (TM)  =O + N	(2) Number of NTEP only meters (non- GIPSA official Meters)  =N	(3) Base Cost per Pool Of NTEP Meters in ongoing Calibration Program  =BC	(4) Total Program Cost (TP)  =N × BC	Funding Contributions from Participants			
				(5) NIST  =TP/3	(6) GIPSA  =TP/3	(7) Total funding from all mfg's meter types  =TM × MCMT	(8) Mfg's Cost Per Meter Type (MCMT)  =TP – NIST = GIPSA
3	1	17,678	17,678	5,893	5,893	17,678	5,893
4	2	17,678	35,356	11,785	11,785	47,141	11,785
5	3	17,678	53,034	17,678	17,678	88,390	17,678
6	4	17,678	70,712	23,571	23,571	141,424	23,571
7	5	17,678	88,390	29,463	29,463	206,243	29,463
8	6	17,678	106,068	30,000	30,000	368,544	46,068
9	7	17,678	123,746	30,000	30,000	573,714	63,746
10	8	17,678	141,424	30,000	30,000	814,240	81,424

NTEP Ongoing Calibration Program Fee Schedule for Year 2016							
(1) Total Meters (including official meter) (TM)  =O + N	(2) Number of NTEP only meters (non- GIPSA official Meters)  =N	(3) Base Cost per NTEP-only Meters in ongoing Calibration Program  =BC	(4) Total Program Cost (TP)  =N × BC	Funding Contributions from Participants			
				(5) NIST  =TP/3	(6) GIPSA  =TP/3	(7) Total funding from all mfg's meter types  =TM × MCMT	(8) Mfg's Cost Per Meter Type (MCMT)  =TP – NIST = GIPSA
3	1	18,064	18,064	6,021	6,021	18,064	6,021
4	2	18,064	36,128	12,043	12,043	48,171	12,043
5	3	18,064	54,192	18,064	18,064	90,320	18,064
6	4	18,064	72,256	24,085	24,085	144,512	24,085
7	5	18,064	90,320	30,000	30,000	212,240	30,320
8	6	18,064	108,384	30,000	30,000	387,072	48,384
9	7	18,064	126,448	30,000	30,000	598,032	66,448
10	8	18,064	144,512	30,000	30,000	845,120	84,512

NTEP Ongoing Calibration Program Fee Schedule for Year 2017							
(1) Total Meters (including official meter) (TM)  =O+N	(2) Number of NTEP only meters (non- GIPSA official Meters)  =N	(3) Base Cost per NTEP only Meters in ongoing Calibration Program  =BC	(4) Total Program Cost (TP)  =N × BC	Funding Contributions from Participants			
				(5) NIST  =TP/3	(6) GIPSA  =TP/3	(7) Total funding from all mfg's meter types  =TM × MCMT	(8) Mfg's Cost Per Meter Type (MCMT)  = TP - NIST - GIPSA
3	1	18,453	18,453	6,151	6,151	18,453	6,151
4	2	18,453	36,906	12,302	12,302	49,208	12,302
5	3	18,453	55,359	18,453	18,453	92,265	18,453
6	4	18,453	73,812	24,604	24,604	147,624	24,604
7	5	18,453	92,265	30,000	30,000	225,855	32,265
8	6	18,453	110,718	30,000	30,000	405,744	50,718
9	7	18,453	129,171	30,000	30,000	622,539	69,171
10	8	18,453	147,624	30,000	30,000	876,240	87,624

NTEP Ongoing Calibration Program Fee Schedule for Year 2018							
(1) Total Meters (including official meter) (TM)  =O+N	(2) Number of NTEP only meters (non- GIPSA official Meters)  =N	(3) Base Cost per NTEP only Meters in ongoing Calibration Program  =BC	(4) Total Program Cost (TP)  =N × BC	Funding Contributions from Participants			
				(5) NIST  =TP/3	(6) GIPSA  =TP/3	(7) Total funding from all mfg's meter types  =TM × MCMT	(8) Mfg's Cost Per Meter Type (MCMT)  = TP - NIST - GIPSA
3	1	18,513	18,513	6,171	6,171	18,513	6,171
4	2	18,513	37,026	12,342	12,342	49,368	12,342
5	3	18,513	55,539	18,513	18,513	92,565	18,513
6	4	18,513	74,052	24,684	24,684	148,104	24,684
7	5	18,513	92,565	30,000	30,000	227,955	32,565
8	6	18,513	111,078	30,000	30,000	408,624	51,078
9	7	18,513	129,591	30,000	30,000	626,319	69,591
10	8	18,513	148,104	30,000	30,000	881,040	88,104

This publication is available free of charge from: <https://doi.org/10.6028/NIST.SP.1210>

This publication is available free of charge from: <https://doi.org/10.6028/NIST.SP.1210>

NTEP Ongoing Calibration Program Fee Schedule for Year 2019							
(1) Total Meters (including official meter) (TM)	(2) Number of NTEP only meters (non- GIPSA official Meters)	(3) Base Cost Per NTEP only Meters in ongoing Calibration Program	(4) Total Program Cost (TP)	Funding Contributions from Participants			
				(5) NIST	(6) GIPSA	(7) Total funding from all mfg's meter types	(8) Mfg's Cost Per Meter Type (MCMT)
= O + N	= N	= BC	= N × BC	= TP/3	= TP/3	= TM × MCMT	= TP - NIST - GIPSA
3	1	18,576	18,576	6,192	6,192	18,576	6,192
4	2	18,576	37,152	12,384	12,384	49,536	12,384
5	3	18,576	55,728	18,576	18,576	92,880	18,576
6	4	18,576	74,304	24,768	24,768	148,608	24,768
7	5	18,576	92,880	30,000	30,000	230,160	32,880
8	6	18,576	111,456	30,000	30,000	411,648	51,456
9	7	18,576	130,032	30,000	30,000	630,288	70,032
10	8	18,576	148,608	30,000	30,000	886,080	88,608

NTEP Ongoing Calibration Program Fee Schedule for Year 2015							
(1) Total Meters (including official meter) (TM)	(2) Number of NTEP only meters (non- GIPSA official Meters)	(3) Base Cost per NTEP only Meters in ongoing Calibration Program	(4) Total Program Cost (TP)	Funding Contributions from Participants			
				(5) NIST	(6) GIPSA	(7) Total funding from all mfg's meter types	(8) Mfg's Cost Per Meter Type (MCMT)
= O + N	= N	= BC	= N × BC	= TP/3	= TP/3	= TP - NIST - GIPSA	= (TP - NIST - GIPSA)/TM
3	1	17,678	17,678	5,893	5,893	5,893	1,964
4	2	17,678	35,356	11,785	11,785	11,785	2,946
5	3	17,678	53,034	17,678	17,678	17,678	3,536
6	4	17,678	70,712	23,571	23,571	23,571	3,928
7	5	17,678	88,390	29,463	29,463	29,463	4,209
8	6	17,678	106,068	30,000	30,000	46,068	5,759
9	7	17,678	123,746	30,000	30,000	63,746	7,083
10	8	17,678	141,424	30,000	30,000	81,424	8,142

This publication is available free of charge from: <https://doi.org/10.6028/NIST.SP.1210>

<b>NTEP Ongoing Calibration Program Fee Schedule</b>							
<b>For Year 2016</b>							
(1) Total Meters (including official meter) (TM)  = O+N	(2) Number of NTEP only meters (non- GIPSA official Meters)  = N	(3) Base Cost per NTEP only Meters in ongoing Calibration Program  = BC	(4) Total Program Cost (TP)  = N × BC	Funding Contributions from Participants			
				(5) NIST  = TP/3	(6) GIPSA  = TP/3	(7) Total funding from all mfg's meter types  = TP – NIST – GIPSA	(8) Mfg's Cost Per Meter Type (MCMT)  = (TP – NIST – GIPSA)/TM
3	1	18,064	18,064	6,021	6,021	6,021	2,007
4	2	18,064	36,128	12,043	12,043	12,043	3,011
5	3	18,064	54,192	18,064	18,064	18,064	3,613
6	4	18,064	72,256	24,085	24,085	24,085	4,014
7	5	18,064	90,320	30,000	30,000	30,320	4,331
8	6	18,064	108,384	30,000	30,000	48,384	6,048
9	7	18,064	126,448	30,000	30,000	66,448	7,383
10	8	18,064	144,512	30,000	30,000	84,512	8,451

<b>NTEP Ongoing Calibration Program Fee Schedule</b>							
<b>For Year 2017</b>							
(1) Total Meters (including official meter) (TM)  = O + N	(2) Number of NTEP only meters (non- GIPSA official Meters)  = N	(3) Base Cost per NTEP only Meters in ongoing Calibration Program  = BC	(4) Total Program Cost (TP)  = N × BC	Funding Contributions from Participants			
				(5) NIST  = TP/3	(6) GIPSA  = TP/3	(7) Total funding from all mfg's meter types  = TP – NIST – GIPSA	(8) Mfg's Cost Per Meter Type (MCMT)  = (TP – NIST – GIPSA)/TM
3	1	18,453	18,453	6,151	6,151	6,151	2,050
4	2	18,453	36,906	12,302	12,302	12,302	3,076
5	3	18,453	55,359	18,453	18,453	18,453	3,691
6	4	18,453	73,812	24,604	24,604	24,604	4,101
7	5	18,453	92,265	30,000	30,000	32,265	4,609
8	6	18,453	110,718	30,000	30,000	50,718	6,340
9	7	18,453	129,171	30,000	30,000	69,171	7,686
10	8	18,453	147,624	30,000	30,000	87,624	8,762

This publication is available free of charge from: <https://doi.org/10.6028/NIST.SP.1210>

<b><u>NTEP Ongoing Calibration Program Fee Schedule</u></b>							
<b><u>For Year 2018</u></b>							
(1) Total Meters (including official meter) (TM)  = O + N	(2) Number of NTEP only meters (non- GIPSA official Meters)  = N	(3) Base Cost per NTEP only Meters in ongoing Calibration Program  = BC	(4) Total Program Cost (TP)  = N × BC	Funding Contributions from Participants			
				(5) NIST  = TP/3	(6) GIPSA  = TP/3	(7) Total funding from all mfg's meter types  = TP-NIST- GIPSA	(8) Mfg's Cost Per Meter Type (MCMT)  = (TP-NIST- GIPSA)/TM
3	1	18,513	18,513	6,171	6,171	6,171	2,057
4	2	18,513	37,026	12,342	12,342	12,342	3,086
5	3	18,513	55,539	18,513	18,513	18,513	3,703
6	4	18,513	74,052	24,684	24,684	24,684	4,114
7	5	18,513	92,565	30,000	30,000	32,565	4,652
8	6	18,513	111,078	30,000	30,000	51,078	6,385
9	7	18,513	129,591	30,000	30,000	69,591	7,732
10	8	18,513	148,104	30,000	30,000	88,104	8,810

<b><u>NTEP On-going Calibration Program Fee Schedule</u></b>							
<b><u>For Year 2019</u></b>							
(1) Total Meters (including official meter) (TM)  = O + N	(2) Number of NTEP only meters (non- GIPSA official Meters)  = N	(3) Base Cost Per NTEP only Meters in ongoing Calibration Program  = BC	(4) Total Program Cost (TP)  = N × BC	Funding Contributions from Participants			
				(5) NIST  = TP/3	(6) GIPSA  = TP/3	(7) Total funding from all mfg's meter types  = TP – NIST – GIPSA	(8) Mfg's Cost Per Meter Type (MCMT)  = (TP – NIST – GIPSA)/TM
3	1	18,576	18,576	6,192	6,192	6,192	2,064
4	2	18,576	37,152	12,384	12,384	12,384	3,096
5	3	18,576	55,728	18,576	18,576	18,576	3,715
6	4	18,576	74,304	24,768	24,768	24,768	4,128
7	5	18,576	92,880	30,000	30,000	32,880	4,697
8	6	18,576	111,456	30,000	30,000	51,456	6,432
9	7	18,576	130,032	30,000	30,000	70,032	7,781
10	8	18,576	148,608	30,000	30,000	88,608	8,861

## 7. Test Weight per Bushel Acceptance and Maintenance Tolerance

### Source:

Mr. Jeffrey D. Adkisson, Grain and Feed Association of Illinois

### Purpose:

Due to problems cited in the grain and feed industry, review and make any needed changes to the test weight per bushel tolerances in NIST Handbook 44 Section 5.56(a).

### Item under Consideration:

During the discussion of this item at the 2012 Sector meeting, it was noted that because the system is rapidly changing over to the new UGMA technology, which is going to result in the improvement in test weight (TW) readings, TW should resolve itself as older instruments are retired. It was also mentioned test weight data is needed to review the current system to make any needed changes to TW per bushel and that sample selection when testing meters for test weight, should be reviewed. It was recommended that TW per bushel comparison charts be developed for review. Cathy Brenner developed these charts and the charts are available for review or can be downloaded for printing at the following web address:

[http://www.ncwm.net/resources/dyn/files/1081742zef27d924/\\_fn/TW+2013+Sector+Meeting.pdf](http://www.ncwm.net/resources/dyn/files/1081742zef27d924/_fn/TW+2013+Sector+Meeting.pdf)

### Background/Discussion:

This is a carryover from the Sector's 2011 meeting. Mr. Adkisson, Grain and Feed Association of Illinois, cited problems his industry is having regarding TW per bushel. GMMs that have failed TW during field inspection are sent to the manufacturer for repair. When the meters are returned, the reports indicate that no problems have been found. There are also situations where a meter has failed TW. When the state inspector subsequently tested the elevator's quart kettle, it matched the meter, but it didn't match the state inspector's sample. This is particularly frustrating for the country elevators in Illinois that are using the GMM TW only as a screening tool.

At the Sector's August 2011 meeting, a task group was formed to investigate the whole TW system with the goal of defining procedures that would improve TW both for the user and for the inspection system. Past data obtained by the Sector had indicated that the existing tolerances were reasonable. It was decided that increasing TW tolerances would only cover up the problems. What was needed was an investigation of the whole system of calibrating meters, then translating that calibration into the field, and then keeping it that way.

Dr. Charles R. Hurburgh, Jr., Iowa State University, agreed to head the task group. Other TW Task Group members included:

- Mr. Jeffery Adkisson – Grain and Feed Association of Illinois
- Ms. Diane Lee – NIST, OWM
- Ms. Cassie Eigenmann – DICKEY-john Corporation
- Mr. Ivan Hankins – Iowa Department of Agriculture/Weights and Measures
- Mr. Tim Kaeding – Perten Instruments, Inc.
- Mr. Karl Cunningham – Illinois Department of Agriculture

Further action on the issue of tolerances was postponed until the TW Task Group was able to recommend appropriate action.

In Early 2012, the TW Task Group developed the following list of Action Items:

- Survey the grain industry as to the frequency of discounting each of the major grains (wheat, corn, and soybeans) for test weight, and within those discounted the frequency of use of the meter test weight versus the cup-bucket test weight.

- Survey the industry for comparative data between meters and an Official GIPSA agency on the same samples.
- Develop a draft procedure for sample selection and pre-qualification.

Dr. Hurburgh reported that discounting for low TW was not an issue in either 2010 or 2011. TWs for corn were so high that discounting was not an issue. Within Iowa most grain elevators were using the TW reported by their GMM. Only a few were using the standard quart kettle method. This is likely to change in the 2012 harvest as low TWs are likely to be more common. Also, there may not be as much TW increase in drying as would normally be expected. TW may come up again as a discount factor.

Same sample TW data has not been collected comparing grain elevator GMMs with an Official GIPSA agency. Dr. Hurburgh explained that this information should be relatively easy to obtain, because in almost every case, when a train is officially graded, the samples are run at the grain elevator first. Since last year's Sector meeting, the rapid acceptance of the new UGMA GMMs as Official Meters for corn, soybeans, sunflowers, and grain sorghum (with the remaining grains scheduled to switch to UGMA GMMs for Official Inspection on May1, 2013) has altered some of the issues. The new technology not only provides a better moisture measurement, but a better TW measurement as well.

The remaining action item that the task group believed was necessary was a procedure for pre-qualifying TW samples as being good predictors for the TW function as well as moisture function. Most states pre-screen moisture samples to get the outliers out of the system. That pre-qualification would have to be expanded if TW is to be actively used to reject meters on the basis of TW.

Dr. Hurburgh recommended that the Sector not adjust TW tolerances at this time, because the system is rapidly changing over to the new technology, which is going to result in the improvement in TW readings. The problem should resolve itself as older instruments are retired.

Mr. Karl Cunningham, Illinois Dept. of Agriculture, informed the Sector that Illinois's TW rejection rate has gone down in the last two years. He has no problem with TW on the meters in his laboratory and doesn't think the present tolerances are a problem. Many of the field problems may be due to rough handling of the meters during shipping. Mr. Cunningham advises elevators who have to have their devices worked on to take them to the manufacturer's service department themselves if at all possible.

Mr. Tim Kaeding, Perten Instruments, suggested that there might be value in expanding the Phase II OCP grain moisture comparison charts to include TW. Dr. Hurburgh recommended that a TW comparison chart showing the spread of TW measurements for individual meters against the corresponding official quart kettle TW measurements would address the tolerance issue, whereas a bias plot would not. He suggested plotting meter TWs on the x-axis and quart kettle results on the y-axis. A best-fit line could be drawn for each meter.

The Sector agreed that TW comparison charts should be prepared for the three grains that are most likely to be subject to discounts on the basis of TW: Corn and two wheat classes. The wheat classes selected were Hard Red Winter and Soft Red Winter. Manufacturer approval is required for NTEP Phase II TW performance data to be released for publication even if individual instruments are not identified. The two meter manufacturers present indicated that they would approve the release of this data. Permission would have to be obtained from the other manufacturers. The Sector agreed to postpone further action on changing TW tolerances until more information was available.

At the August 2013 Sector Meeting, Ms. Brenner reviewed test weight per bushel data for Corn, Hard Red Winter Wheat, and Soft Red Winter Wheat (see charts below). The data showed the NTEP meters aligned closely with the official quart kettle test weight per bushel measurements. States noted that they have seen a significant improvement in test weight per bushel measurements and lower complaints have been received concerning test weight. Mr. Karl Hansan stated he is collecting data on the moisture changes in grain samples over time when using the samples in the field. This data can be used to improve the field inspection of the test weight per bushel measurements on grain analyzers. Ms. Lee provided a draft copy of a weights and measures newsletter article entitled "Determining Reference Test Weight per Bushel Value of Grains." Following the August Sector Meeting the article was published in the Weights and Measures Newsletter and can be accessed at: . This article will help to ensure that states are following

proper procedures when assigning reference test weight per bushel values to grains used to test instruments that provide test weight per bushel measurements.

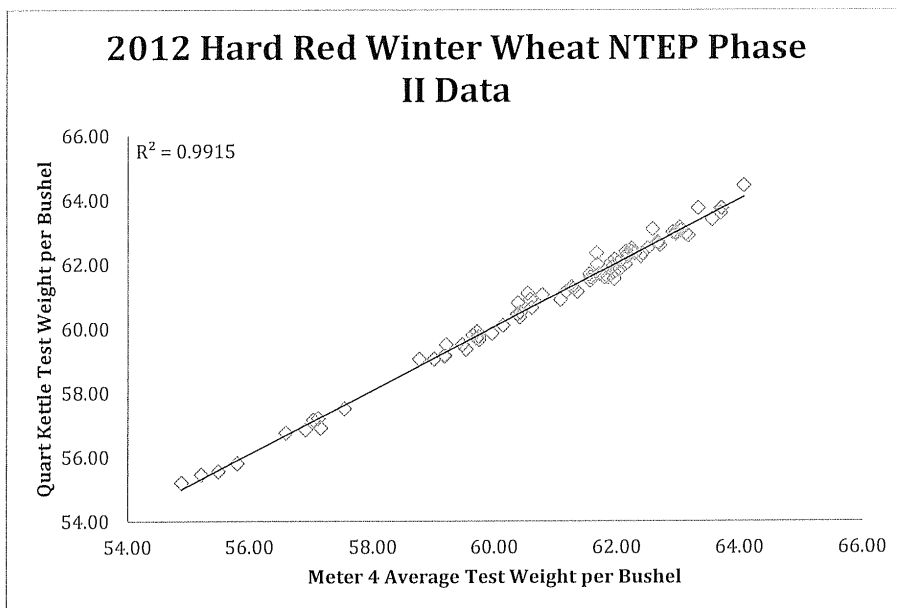
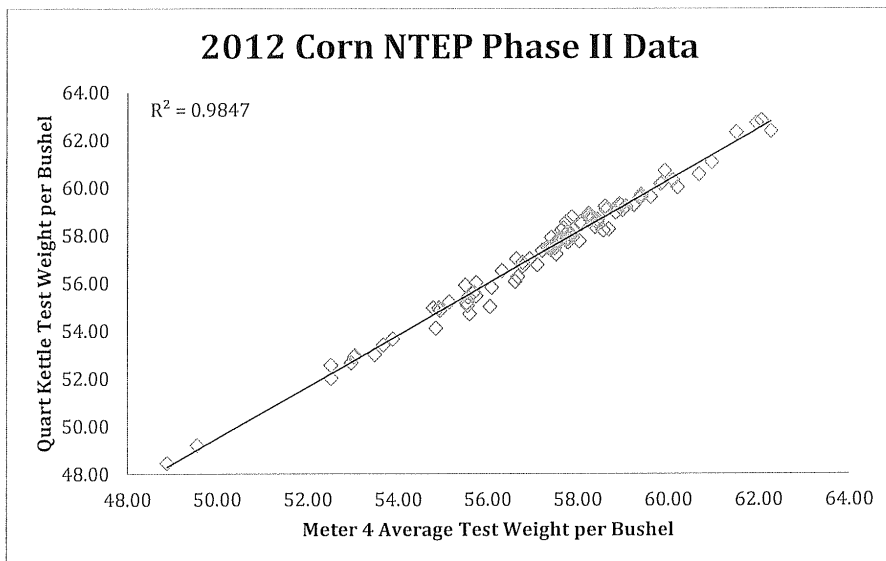



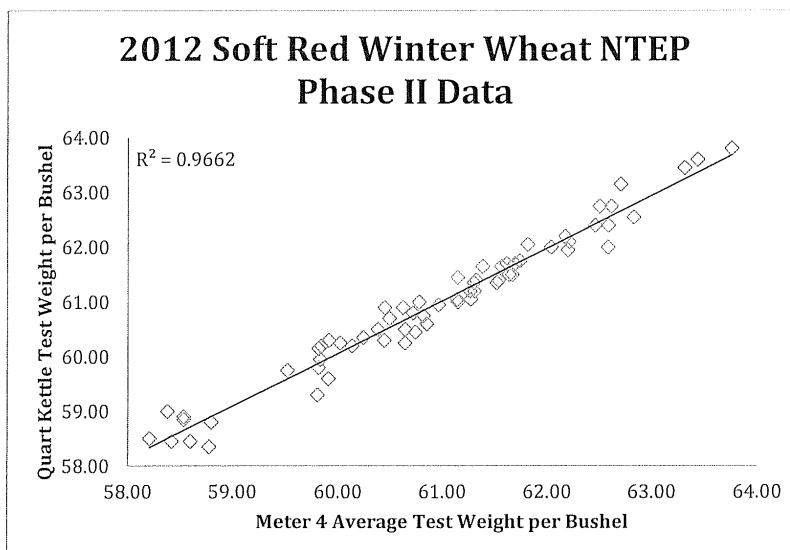

At the August 2014 Grain Analyzer Sector meeting, Mr. Hanson noted that due to time constraints he was unable to collect data on test weight per bushel measurements of field grain samples. Mr. Jeffrey Adkisson, Grain and Feed Association of Illinois, reported that the number of complaints concerning test weight has dropped. He also noted that he was not sure if it was due to the growing season or if better test procedures are being used by state weights and measures officials. Manufacturers and others noted they would like the weight per bushel charts to continue to determine how test weight is affected by crop issues.

## 8. Report on International Organization of Legal Metrology (OIML) TC 17/SC 1 R 59 Moisture Meters for Cereal Grains and Oilseeds

### Background/Discussion:

This item is included on the Sector's agenda to provide a summary of the activities of OIML TC 17/SC 1 for the Grain Analyzer Sector and to those Sector members that participate on the U.S. National Working Group (USNWG) on grain moisture meters. In addition, the Sector is asked to review a proposal to change the humidity test in NCWM Publication 14 to align with the OIML D 11 and IEC damp heat test procedure.

OIML TC 17/SC 1 was tasked to revise OIML R 59, *Moisture Meters for Cereal Grains and Oilseeds*, to reflect new technologies and actual grain analysis. The Co-Secretariats (China and the United States) are working closely with an International Project Group to revise OIML Recommendation R 59, *Moisture Meters for Cereal Grains and Oilseeds*. The United States completed a sixth committee draft (6 CD) of OIML R 59, which was circulated to the international project group and the USNWG on grain moisture measuring devices for review and comment on March 6, 2013. The U.S. Co-secretariat requested that the comments to the 6 CD be submitted by June 6, 2013. The U.S. Secretariat collated the U.S. and international comments to the 6 CD and these comments were reviewed at the TC 17/SC 1 meeting hosted by NIST, OWM July 23 - 24, 2013.

At the TC 17/SC 1 July 23 - 24, 2013, meeting, comments to the 6 CD were reviewed and the major discussion was harmonization of test procedures between OIML TC 17/SC 1 R 59, *Moisture Meters for Cereal Grains and Oilseeds*, and OIML TC 17/SC 8 Recommendation on *Protein Measuring Instruments for Cereal Grain and Oil Seeds*.

At the July 2013 meeting, it was discussed that the international damp heat test (OIML D 11 and IEC) is significantly different from the NTEP Humidity test. The international test is more robust and more accurately reflects the environmental conditions an instrument is likely to encounter in field use. The damp heat test is conducted at a maximum temperature of either the manufacturer specified upper ambient temperature or 30 °C and a maximum relative humidity of 85 %. The damp heat test is designed to evaluate the device under the environmental (temperature and relative humidity) conditions it will encounter during operation.

During the August 2013 Grain Analyzer Sector meeting, the Sector reviewed the proposal to replace the NCWM, NTEP Publication 14 GMM and NIR Humidity test procedure with the OIML D 11 Damp Heat test procedure. It was noted that the proposed changes to the humidity test in NCWM Publication 14 were based on OIML D 11 requirements Damp heat test, Severity level 1. During discussion of this item, it was mentioned that the temperature and humidity levels as specified in OIML D 11 may pose unsafe operating conditions to laboratory staff and also that grain moisture meters are not designed to operate in these extreme conditions. A question was asked if another severity level in D 11 would more closely match the testing that is currently in NCWM Publication 14 and that has been used for many years in the United States. Ms. Lee, reviewed OIML D 11 requirements following the meeting and found that both severity level 1 and 2 exceed the temperature and humidity levels specified in NCWM Publication 14. The Sector agreed by consensus that the OIML D 11, Damp heat test, is much too severe for grain moisture meters and that NCWM Publication 14 should not be changed to meet the requirements of OIML D 11.

The United States will develop a 7 CD that will be distributed for voting based on comments to the 6 CD, the July 2013 TC.

At the August 2014 Grain Analyzer Sector meeting, Ms. Diane Lee, NIST, OWM, provided an update on the status of the 7 CD on *Moisture Meters for Cereal Grains and Oilseed*. Ms. Lee reported that the United States is nearing completion of the 7 CD on *Moisture Meters for Cereal Grains and Oilseed*. This document will be forwarded to the TC 17/SC 1 participating and observing countries for a vote and will also be forwarded to participants of the USNWG on Grain Moisture Measuring Devices for vote and comment.

## 9. Report on OIML TC 17/SC 8 *Protein Measuring Instruments for Cereal Grain and Oil Seeds*

### Background/Discussion:

This item was included on the Sector's agenda to provide a summary of the activities of OIML TC 17/SC 8 to the grain analyzer sector and to those Sector members that participate on the USNWGUSNWG on grain protein measuring instruments. OIML TC 17/SC 8 was formed to study the issues and to develop a Recommendation on *Protein Measuring Instruments for Cereal Grain and Oil Seeds*. Australia is the Secretariat for this Subcommittee. The third committee draft (3 CD) for this Recommendation was circulated to the USNWG for comments on July 3, 2012, for review and comment and comments were due by September 8, 2012. The U.S. comments to the 3 CD were forwarded to the secretariat, and the secretariat developed the 4 CD based on these comments.

The 4 CD was circulated to the USNWG on grain protein measuring instruments on April 9, 2013, and comments to the 4 CD of TC 17/SC 8 were due by June 13, 2013. The U.S. comments to the 4 CD were forwarded to the secretariat. The United States was requested to vote on the 4 CD and a vote of no was provided due to a number of differences in the test procedures of the OIML Recommendation for *Protein Measuring Instruments for Cereal Grain and Oil Seeds* and the OIML R 59 *Moisture Meters for Cereal Grain and Oilseeds*.

A meeting was hosted by NIST, OWM, July 24 - 25, 2013, to discuss the comments to the 4 CD for the Recommendation on *Protein Measuring Instruments for Cereal Grain and Oil Seeds*. Discussions on 4 CD dealt mostly with harmonization of testing with the 6 CD of the OIML Recommendation R 59 *Moisture Meters for Cereal Grain and Oilseeds*, software requirements, and influence quantities and test sample temperature.

At the August 2013 Grain Analyzer Sector meeting, the Sector reiterated their concerns with the OIML D 11 damp heat test and agreed that the damp heat test in the OIML recommendation on Protein Measuring Instruments for Cereal Grain and Oil Seeds, 4 CD should be replaced with the humidity test as written in OIML R 59 CD 6.

The TC 17/SC 8 Secretariat will distribute a 5 CD for voting.

At the August 2014 Grain Analyzer Sector meeting, Ms. Lee, NIST, OWM, provided an update on the status of the 5 CD on *Protein Measuring Instruments for Cereal Grain and Oil Seeds*. The 5 CD on *Protein Measuring Instruments for Cereal Grain and Oil Seeds* was sent via e-mail to the USNWG on Protein Measuring Device on August 26, 2014, for a vote and comments. The USNWG participants were requested to provide their vote and any comments to the 5 CD by October 14, 2014. Ms. Lee encouraged the Grain Analyzer Sector members that are also participating on the

USNWG to provide a vote and any comment to the 5 CD on Protein *Measuring Instruments for Cereal Grain and Oil Seed*.

## 10. Software Sector Items

### (a) Identification of Certified Software

**Source:**

NTETC Software Sector

**Purpose:**

Review and provide comment to the Software Sector reports and conclusion on software issues.

**Background:**

This item originated as an attempt to answer the question, “How does the field inspector know that the software running in the device is the same software evaluated and approved by the lab?” In previous meetings, it was shown that the international community has addressed this issue (both WELMEC and OIML).

*From WELMEC 7.2:*

**Required Documentation:**

The documentation shall list the software identifications and describe how the software identification is created, how it is inextricably linked to the software itself, how it may be accessed for viewing and how it is structured in order to differentiate between version changes with and without requiring a type approval.

*From OIML D-31:*

The executable file “**tt100\_12.exe**” is protected against modification by a checksum. The value of checksum as determined by algorithm **XYZ** is **1A2B3C**.

Previous discussions have included a listing of some additional examples of possible valid methods (not limiting):

- CRC (cyclical redundancy check)
- Checksum
- Inextricably Linked version no.
- Encryption
- Digital Signature

**Is there some method to give the weights and measures inspector information that something has changed?**

Yes, the Category III Audit Trail or other means of sealing.

**How can the weights and measures inspector identify an NTEP Certified version?**

They can't, without adding additional requirements like what is described here, in conjunction with including the identifier on the CC).

The Sector believes that we should work towards language that would include a requirement similar to the International Organization of Legal Metrology (OIML) requirement in NIST Handbook 44. It is also the opinion of the Sector that a specific method should not be defined; rather the manufacturer should utilize a method and demonstrate the selected identification mechanism is suitable for the purpose. It is not clear from the discussion where such proposed language might belong.

NTEP strongly recommends metrological software be separated from non-metrological software for ease of identification and evaluation.

*From OIML:*

Separation of software parts – All software modules (programmes, subroutines, objects etc.) that perform metrologically significant functions or that contain metrologically significant data domains form the metrologically significant software part of a measuring instrument (device or sub-assembly). The conformity requirement applies to all parts and parts shall be marked according to Section G-S.X.X.

If the separation of the software is not possible or needed, then the software is metrologically significant as a whole.

(Segregation of parameters is currently allowed – see table of sealable parameters)

*Initial draft proposed language: (G-S.1.1?)*

NIST Handbook 44 (This has been written into G-S.1.d.3): Identification of Certified Software:

**Software-based electronic devices shall be designed such that the metrologically significant software is clearly identified by the version or revision number. The identification, and this identification of the software shall be inextricably directly and inseparably linked to the software itself. The version or revision number may consist of more than one part, but at least one part shall be dedicated to the metrologically significant software.**

*From NCWM Publication 14:*

Identification of Certified Software:

**Note:** Manufacturers may choose to separate metrologically significant software from non-metrologically significant software. Separation would allow the revision of the non-metrological portion without the need for further evaluation. In addition, non-metrologically significant software may be updated on devices without breaking a seal, if so designed. Separation of software requires that all software modules (programs, subroutines, objects etc.) that perform metrologically significant functions or that contain metrologically significant data **domains** form the metrologically significant software part of a measuring instrument (device or sub-assembly). If the separation of the software is not possible or needed, then the software is metrologically significant as a whole. ~~The conformity requirement applies to all parts and parts shall be marked according to Section G-S.X.X.~~

The manufacturer must describe and possibly demonstrate how the version or revision identifier is directly and inseparably linked to the metrologically significant software. Where the version revision identifier is comprised of more than one part, the manufacturer shall describe which portion represents the metrological significant software and which does not.

*From OIML D-31:*

Legally relevant software of a measuring instrument/electronic device / sub-assembly shall be clearly identified with the software version or another token. The identification may consist of more than one part but at least one part shall be dedicated to the legal purpose.

The identification shall be inextricably linked to the software itself and shall be presented or printed on command or displayed during operation or at start up for a measuring instrument that can be turned off and on again. If a sub-assembly/an electronic device has neither display nor printer, the identification shall be sent via a communication interface in order to be displayed/printed on another sub-assembly/electronic device.

The first sentence of the first paragraph above is already addressed in NIST Handbook 44's marking requirements.

In 2010, the Sector recommended the following change to NIST Handbook 44, General Code: G-S.1(d) to add a new subsection (3):

- (d) *the current software version or revision identifier for ~~not-built-for-purpose~~ software-based electronic devices;*  
[Nonretroactive as of January 1, 2004]  
(Added 2003) **(Amended 20XX)**
- (1) *The version or revision identifier shall be prefaced by words, an abbreviation, or a symbol, that clearly identifies the number as the required version or revision.*  
[Nonretroactive as of January 1, 2007]  
(Added 2006)
- (2) *Abbreviations for the word "Version" shall, as a minimum, begin with the letter "V" and may be followed by the word "Number." Abbreviations for the word "Revision" shall, as a minimum, begin with the letter "R" and may be followed by the word "Number." The abbreviation for the word "Number" shall, as a minimum, begin with the letter "N" (e.g., No or No.).*  
[Nonretroactive as of January 1, 2007]  
(Added 2006)
- (3) The version or revision identifier shall be directly and inseparably linked to the software itself. The version or revision identifier may consist of more than one part, but at least one part shall be dedicated to the metrologically significant software.**  
**[Nonretroactive as of January 1, 201X]**  
**(Added 20XX)**

Also the Sector recommended the following information be added to NCWM Publication 14 as explanation/examples:

- Unique identifier must be displayable/printable on command or during operation, etc.
- At a minimum, a version/revision indication (1.02.09, rev 3.0 a, etc.). Could also consist of/contain checksum, etc. (crc32, for example)

There was some additional discussion on this item regarding where this new requirement would be best located. It was suggested that the first sentence of G-S.1.d.(3) could be added as a clause to the base paragraph G-S.1.(d) text, for example, "*the current software version or revision identifier for ~~not-built-for-purpose~~ software-based devices, which shall be directly and inseparably linked to the software itself;*".

It also was suggested that the second sentence in G-S.1.d.(3) might be more suitable for NCWM Publication 14, as it describes more "how" than "what" the requirement entails.

In addition, the Sector considered the following information to be added to NCWM Publication 14 as explanation/examples:

- The current software identifier must be displayable/printable on command during operation (or made evident by other means deemed acceptable by G-S.1.)
- At a minimum, the software identifier must include a version/revision indication (1.02.09, rev 3.0 a, etc.). It could also consist of/contain check sum, etc. (crc32, for example).
- The version or revision identifier may consist of more than one part, but at least one part shall be dedicated to the metrologically significant software.

Other questions that are still outstanding:

- If we allow hard-marking of the software identifier (the Sector has wavered on this in the past), does the above wording then imply that some mechanical means is required (i.e., physical seal) to “inseparably link” the identifier to the software?
- If a device is capable of doing so, does it still have to be able to display, print or communicate the identifier somehow, even if it is hard-marked?

At the 2012 NTETC Software Sector meeting, there was some discussion as to where the terminology regarding inextricably linking the software version or revision to the software itself belonged. At the moment, it is not incorporated in the proposed text for G-S.1. NCWM Publication 14 may be a better option for the time being. This would be another item that would benefit from further explanation in a supplementary document.

Several Sector members were of the opinion that attempting to make this change at the same time as the earlier changes might be a difficult sell. Mr. Truex, NTEP Administrator, reiterated the necessity of baby steps.

In 2012, the Sector, thus, recommended adding the following to NCWM Publication 14 and forwarding to NTETC Weighing, Measuring, Grain Analyzer Sectors for feedback:

#### Identification of Certified Software:

Note: Manufacturers may choose to separate metrologically significant software from non-metrologically significant software. Separation would allow the revision of the non-metrological portion without the need for further evaluation. In addition, non-metrologically significant software may be updated on devices without breaking a seal, if so designed. Separation of software requires that all software modules (programs, subroutines, objects etc.) that perform metrologically significant functions or that contain metrologically significant data domains form the metrologically significant software part of a measuring instrument (device or sub-assembly). If the separation of the software is not possible or needed, then the software is metrologically significant as a whole. The conformity requirement applies to all parts and parts shall be marked according to Section G-S.X.X.

The manufacturer must describe and possibly demonstrate how the version or revision identifier is directly and inseparably linked to the metrologically significant software. Where the version revision identifier is comprised of more than one part, the manufacturer shall describe which portion represents the metrological significant software and which does not.

#### Discussion:

The Measuring Sector reviewed this item and had no feedback other than a statement that they support the continuing/ongoing efforts of this Sector. The Weighing Sector summary mentioned that no one opted to provide comment. They agreed to take no further action on this item, pending further action from the Software Sector. This was specifically in reference to the accepted symbols.

For the time being, Jim Truex recommended that we not attempt to provide a definition for “software-based device.” We discussed the possibility of combining this change with the first agenda item, which had been attempted in previous years. Alternatively, if the NIST Handbook 44 changes from agenda Item 1 are made, this agenda item could be addressed in NCWM Publication 14.

#### Conclusion:

After further discussion, the wording in G-S.1.d under agenda Item 1 was changed. Agenda Item 2 will remain; however, it will address potential changes to NCWM Publication 14 and contain no suggested modifications to NIST Handbook 44. (See changes and conclusion under agenda Item 1 for further details.)

The Sector chair volunteered to review the existing slide presentation detailing the purpose of these changes, to ensure that it accurately reflects this information.

**(b) Software Protection/Security**

**Source:**

NTETC Software Sector

**Background:**

The Sector agreed that NIST Handbook 44 already has audit trail and physical seal requirements, but these may need to be enhanced.

*From the WELMEC Document:*

**Protection against accidental or unintentional changes:**

Metrologically significant software and measurement data shall be protected against accidental or unintentional changes.

**Specifying Notes:**

Possible reasons for accidental changes and faults are: unpredictable physical influences, effects caused by user functions and residual defects of the software even though state of the art of development techniques have been applied.

This requirement includes consideration of:

- a) Physical influences: Stored measurement data shall be protected against corruption or deletion when a fault occurs or, alternatively, the fault shall be detectable.
- b) User functions: Confirmation shall be demanded before deleting or changing data.
- c) Software defects: Appropriate measures shall be taken to protect data from unintentional changes that could occur through incorrect program design or programming errors (e.g., plausibility checks).

**Required Documentation:**

The documentation should show the measures that have been taken to protect the software and data against unintentional changes.

**Example of an Acceptable Solution:**

- The accidental modification of software and measurement data may be checked by calculating a checksum over the relevant parts, comparing it with the nominal value and stopping if anything has been modified.
- Measurement data are not deleted without prior authorization (e.g., a dialogue statement or window asking for confirmation of deletion).
- For fault detection see also Extension I.

The Sector continued to develop a proposed checklist for NCWM Publication 14. The numbering will still need to be added. This is based roughly on R 76-2 checklist and discussions beginning as early as the October 2007 NTETC Software Sector Meeting. The information requested by this checklist is currently voluntary; however, it is recommended that applicants comply with these requests or provide specific information as to why they may not be able to comply. Based on this information, the checklist may be amended to better fit with NTEP's need for information and the applicant's ability to comply.

The California, Maryland, and Ohio laboratories agreed to use this check list on one of the next devices they have in the lab and report back to the Sector on what the problems may be. In February 2011, the North Carolina laboratory was also given a copy of the check list to try.

This publication is available free of charge from: <https://doi.org/10.6028/NIST.SP.1210>

**1. Devices with ~~Embedded Software~~ TYPE P (aka built-for-purpose)**

- 1.3. Declaration of the manufacturer that the software is used in a fixed hardware and software environment. **AND**  Yes  No  N/A
- 1.4. Cannot be modified or uploaded by any means after securing/verification.  Yes  No  N/A  
*Note: It is acceptable to break the "seal" and load new software, audit trail is also a sufficient seal.*
- 1.5. The software documentation contains:
  - 1.5.3. Description of all functions, designating those that are considered metrologically significant.  Yes  No  N/A
  - 1.5.4. Description of the securing means (evidence of an intervention).  Yes  No  N/A
  - 1.5.5. Software Identification, including version/revision  Yes  No  N/A
  - 1.5.6. Description how to check the actual software identification.  Yes  No  N/A
- 1.6. The software identification is:
  - 1.6.7. Clearly assigned to the metrologically significant software and functions.  Yes  No  N/A
  - 1.6.1. Description how to check the actual software identification.  Yes  No  N/A
  - 1.6.2. Provided by the device as documented.  Yes  No  N/A
  - 1.6.3. Directly linked to the software itself.  **Yes**  **No**  **N/A**

**2. ~~Personal Computers, Instruments with PC Components, and Other Instruments, Devices, Modules, and Elements with Programmable or Loadable Metrologically Significant Software~~ TYPE U (aka not built-for-purpose)**

- 2.1. The metrologically significant software is:
  - 2.1.4. Documented with all relevant (see below for list of documents) information.  Yes  No  N/A
  - 2.1.5. Protected against accidental or intentional changes.  Yes  No  N/A
- 2.2. Evidence of intervention (such as, changes, uploads, circumvention) is available until the next verification/inspection (e.g., physical seal, Checksum, Cyclical Redundancy Check (CRC), audit trail, etc. means of security).  Yes  No  N/A

**3. Software with ~~Closed Shell~~ (no access to the operating system and/or programs possible for the user)**

- 3.1. Check whether there is a complete set of commands (e.g., function keys or commands via external interfaces) supplied and accompanied by short descriptions.  Yes  No  N/A
- 3.2. Check whether the manufacturer has submitted a written declaration of the completeness of the set of commands.  Yes  No  N/A

**4. Operating System and/or Program(s) Accessible for the User**

- 4.1. Check whether a checksum or equivalent signature is generated over the machine code of the metrologically significant software (program module(s) subject to legal control Weights and Measures jurisdiction and type-specific parameters).  Yes  No  N/A



- 4.2. Check whether the metrologically significant software will detect and act upon any unauthorized alteration of the metrologically significant software using simple software tools (e.g., text editor).  Yes  No  N/A

## 5. Software Interface(s)

### 5.1. Verify the manufacturer has documented:

- 5.1.6. The program modules of the metrologically significant software are defined and separated.  Yes  No  N/A
- 5.1.7. The protective software interface itself is part of the metrologically significant software.  Yes  No  N/A
- 5.1.8. The functions of the metrologically significant software that can be accessed via the protective software interface.  Yes  No  N/A
- 5.1.9. The parameters that may be exchanged via the protective software interface are defined.  Yes  No  N/A
- 5.1.10. The description of the functions and parameters are conclusive and complete.  Yes  No  N/A
- 5.1.11. There are software interface instructions for the third party (external) application programmer.  Yes  No  N/A

The Maryland laboratory had particular questions regarding 3.1 and 5.1. The information for 3.1 could be acquired from an operator's manual, a training video, or in-person training. The items in 5.1 were confusing to the evaluators. The terminology is familiar to software developers, but not necessarily others. It was indicated that manufacturers were typically quick to return the filled out questionnaire, but lab staff did not know how to verify the information was true. Generally, the laboratories wouldn't be expected to verify things to that level. For example, if the manufacturer states that a checksum is used to ensure integrity, the laboratories wouldn't be expected to evaluate the algorithm used.

The intent was to see whether the manufacturer had at least considered these issues, not for evaluators to become software engineers. Perhaps a glossary or descriptive paragraphs might be added to assist the evaluators in the event the manufacturer has questions for the evaluators.

OIML makes use of supplementary documents to explain the checklist they use. Below are links:

<http://www.oiml.org/publications/D/D031-e08.pdf>

<http://www.welmec.org/latest/guides/72.html>

[http://www.welmec.org/fileadmin/user\\_files/publications/2-3.pdf](http://www.welmec.org/fileadmin/user_files/publications/2-3.pdf)

WELMEC document 2.3 is the original source for the checklist, but it's been significantly revised and simplified. Mr. Payne, Maryland Department of Agriculture, is going to review the other documents and come up with some suggestions for the checklist. Mr. Roach, California Division of Measurement Standards, is going to begin using the checklist. The international viewpoint is that any device running an operating system is considered to be Type U. Mr. Roach mentioned that they're having lots of problems with "skimmers" stealing PINs. Is there some way they can detect this?

Mr. Lewis, Rice Lake Weighing Systems, Inc., mentioned that he liked Measurement Canada's website. When answering similar questions, different pages would appear, based on answers to those questions: <http://www.ic.gc.ca/eic/site/mc-mc.nsf/eng/lm00573.html>

At the 2011 NTETC Software Sector Meeting, the laboratories were polled to obtain any feedback on the use of the checklist. Maryland attempted to use this checklist a few times. They had some difficulty obtaining answers from the manufacturers because the individual(s) interacting with the Maryland evaluator didn't always have the required information on hand. More experience in using the checklist will help determine what needs to be revised.

It was suggested that the checklist could be sent to manufacturers for their feedback as well, with the stipulation that it a completely voluntary exercise and purely informational at this point. The laboratories will coordinate with willing manufacturers to obtain feedback.

Work is ongoing on this item with the intent that it eventually will be incorporated as a checklist in NCWM Publication 14; again the laboratories are requested to try utilizing this checklist for any evaluations on software-based electronic devices.

The checklist has been reviewed with an eye to making its terminology clearer to laboratories. Some examples and clarifications have been added as shown in the discussion section of this item. The revised checklist will be distributed to the laboratories for additional review. Maryland and California laboratories agreed to use the checklist on a trial basis.

**Discussion:**

Over the past year, attempts to use the current checklist did not meet with many difficulties. The checklists were given to the manufacturers to fill out, and that seemed to work rather well. Minor modifications (in red above) were made to clarify certain confusing areas or eliminate redundancy.

**Conclusion:**

The next step will be to forward it to the four sectors; we can report that the labs have tried using it on a trial basis and we're ready to recommend it for NCWM Publication 14 with the modification suggested here, such as the removal of the Type P/Type U wording.

**(c) Software Maintenance and Reconfiguration**

**Source:**

NTETC Software Sector

**Background:**

After the software is completed, what do the manufacturers use to secure their software? The following items were reviewed by the Sector. *Note that agenda Item 3 also contains information on Verified and Traced updates and Software Log.*

1. Verify that the update process is documented. (OK)
2. For traced updates, installed Software is authenticated and checked for integrity.

Technical means shall be employed to guarantee the authenticity of the loaded software (i.e., that it originates from the owner of the type approval certificate). This can be accomplished (e.g., by cryptographic means like signing). The signature is checked during loading. If the loaded software fails this test, the instrument shall discard it and either use the previous version of the software **or become inoperative.**

Technical means shall be employed to guarantee the integrity of the loaded software (i.e., that it has not been inadmissibly changed before loading). This can be accomplished for example, by adding a checksum or hash code of the loaded software and verifying it during the loading procedure. If the loaded software fails this test, the instrument shall discard it and either use the previous version of the software **or become inoperative.**

Examples are not limiting or exclusive.

3. Verify that the sealing requirements are met.

The Sector asked, what sealing requirements are we talking about?

This item is **only** addressing the **software update;** it can be either verified or traced. It is possible that there are two different security means, one for protecting software updates (software log) and one for protecting the other

metrological parameters (Category I II or III method of sealing). Some examples provided by the Sector members include but are not limited to:

- Physical Seal, software log; and
  - Category III method of sealing can contain both means of security.
4. Verify that if the upgrade process fails, the device is inoperable or the original software is restored.

The question before the group is, Can this be made mandatory?

The manufacturer shall ensure by appropriate technical means (e.g., an audit trail) that traced updates of metrologically significant software are adequately traceable within the instrument for subsequent verification and surveillance or inspection. This requirement enables inspection authorities, which are responsible for the metrological surveillance of legally controlled instruments, to back-trace traced updates of metrologically significant software over an adequate period of time (that depends on national legislation). The statement in italics will need to be reworded to comply with U.S. weights and measures requirements.

The Sector **agreed** that the two definitions below for Verified Update and Traced Update were acceptable.

#### **Verified Update**

A verified update is the process of installing new software where the security is broken and the device must be re-verified. Checking for authenticity and integrity is the responsibility of the owner/user.

#### **Traced Update**

A traced update is the process of installing new software where the software is automatically checked for authenticity and integrity, and the update is recorded in a software update log or audit trail.

*Note: It's possible that the Philosophy of Sealing section of NCWM Publication 14 may already address the above IF the definitions of Verified and Traced Updates (and the statement below) were to be added. The contrary argument was that it may be better to be explicit).*

**Use of a Category 3 audit trail is required for a Traced Update. A log entry representing a traced software update shall include the software identification of the newly installed version.**

The Sector recommended consolidating the definitions with the above statement thus:

#### **Verified Update**

A verified update is the process of installing new software where the security is broken and the device must be re-verified. Checking for authenticity and integrity is the responsibility of the owner/user.

#### **Traced Update**

A traced update is the process of installing new software where the software is automatically checked for authenticity and integrity, and the update is recorded in a ~~software update log or~~ Category 3 audit trail. The audit trail entry shall include the software identification of the newly installed version.

In 2012, the Sector recommended that as a first step, the following be added to NCWM Publication 14:

**The updating of metrologically significant software, including software that checks the authenticity and integrity of the updates, shall be considered a sealable event.**

Mr. Truex, NTEP Administrator, indicated his opinion that the above sentence is unnecessary since it's self-evident. It was agreed by the group, however, to ask the other sectors for feedback on the value of this addition.

Though the Sector is currently considering only the single sentence be incorporated into NCWM Publication 14 for the time being, ultimately, the Sector may wish to advance the remaining language of the original item submission.

**Discussion:**

The Sector had no information indicating that the other Sectors had yet been approached for feedback on the value of the addition of the proposed sentence.

**Conclusion:**

This Sector would like the other Sectors to evaluate this for inclusion in NCWM Publication 14. They would also like to include some description indicating an existing audit trail should be protected during a software update, though this may already be a requirement. This does appear to be addressed in the Requirements for Metrological Audit Trails Appendices in NCWM Publication 14.

At the August 2013 Grain Analyzer Sector meeting, Mr. Truex provided a review of the Software Sector’s proposals for changes to NCWM Publication 14’s, Identification of Certified Software, Software Protection/Security, and Software Maintenance and Reconfiguration. Manufacturers had a number of questions, including “What is the baseline for which software is considered metrologically significant?” After some discussion, the manufacturers requested that they be given additional time to review the proposed changes and to allow their software designers an opportunity to look at the proposed changes to software. Ms. Brenner sent an e-mail on August 29, 2013, to all NTEP grain analyzer manufacturers requesting that comments be submitted to Ms. Lee by October 15, 2013.

The Grain Analyzer Sector manufacturers provided the following comments to the Software Sector’s proposal for changes to NCWM Publication 14:

<b>Grain Analyzer Manufacturer’s Comments to Software Sector’s Proposed Changes to Publication 14</b>			
<b>Manufacturer</b>	<b>GA Sector Item</b>	<b>Comment</b>	<b>Proposed change</b>
Dickey-john	12a	<p>We currently don’t separate the metrologically significant code or identify it’s version in the application. We can do this, but it will require a significant code change and validation.</p> <p>Question 1: Does the metrological significant code need to be actually separate from the application or is a label in the application identifying the version of the prediction module used acceptable. This will result in less changes to the code.</p> <p>Question 2: What if we had added a test on the prediction module that inserted key values into the engine, that we would document in the metrological specific tests, that would give a specific answer? For example, if the prediction module is the same then the same inputs with the same calibration file will yield the same results from version to version; log those results and include in the metrological report.</p>	<p>Object to 12.a – The document insists that we separate the legally relevant code and make separate binaries.</p> <p>We could simply add a label that is bound to the prediction module code. Adding this label could tie the prediction module to the version, and will allow us to separately maintain revision control of that code. However, the code itself will not be a separate binary.</p>
FOSS	General	<p>Since FOSS distributes instruments worldwide, having NTEP and OIML requirements the same would be beneficial. I know efforts are being made to have the two as similar as possible. A concern is the potential that software code that is adopted would invalidate the currently approved instruments. A preferred outcome would be that once software code is adopted, only instruments</p>	

This publication is available free of charge from: <https://doi.org/10.6028/NIST.SP.1210>

Grain Analyzer Manufacturer's Comments to Software Sector's Proposed Changes to Publication 14			
		seeking approval (not currently approved) would be required to meet the code.	

In addition, manufacturers that attended the August 2013 Grain Analyzer Meeting, expressed an interest in attending the next 2014 Software Sector meeting to provide additional input.

It was noted in the 2014 S&T Annual Report that Developing Item 310-1, G-S.1. Identification was not considered at the 2013 GA Sector meeting. The Sector considered this item at previous Sector meetings, but it was noted that the Software Sector was still developing this item, and the Sector would provide additional feedback following further development. At the 2013 GA Sector meeting, the Sector was asked to provide comments to proposed changes to NCWM Publication 14.

At the 2014 GA Sector Meeting, Mr. Truex will provide an update on the Software Sector activities and the status of Developing Item 310-1, G-S.1. Identification. GA Sector members are requested to provide any additional feedback concerning the Software Sector's proposed changes to publication 14.

At the August 2014 Grain Analyzer Sector meeting, manufacturers discussed the Software Sector's proposal for changes to NCWM Publication 14 for identification of certified software, Software Protection/Security, and Software Maintenance and Reconfiguration. One manufacturer noted the difficulty in separating metrological and non-metrological software. It was noted that if the software is not separated then all software would be considered metrological. The Grain Analyzer Sector had additional questions and made additional comments to the proposed changes to NCWM Publication 14 for identification of certified software, software protection/security, and software maintenance and reconfiguration:

- If the software is not separated, would a manufacturer be required to resubmit the device to NTEP each year for reevaluation?
- Will the requirements for software affect devices that are currently designed and manufactured?
- There are issues with software changes if devices that are already manufactured are required to meet the software requirements.
- It is difficult to redesign devices.

The Grain Analyzer Sector was informed the Software Sector meeting would be held August 27 - 28, 2014. Manufacturers expressed that they needed the requirements so these requirements can be considered in future device designs.

## 11. Update on Proficiency Testing

### Source:

Dr. Hurburgh, Iowa State University

### Purpose:

Develop an air-oven proficiency testing program to ensure state laboratory and manufacturer's air-oven measurements are traceable to the official USDA, GIPSA air-oven measurements.

### Item under Consideration:

Update on progress of the ongoing air-oven proficiency testing program for states maintaining a grain moisture laboratory and GMM manufacturers.

**Background/Discussion:**

At the 2009 NTETC Grain Analyzer Sector meeting, Dr. Hurburgh, Iowa State University, urged the representatives from the American Oil Chemists Society (AOCS) to prepare a proposal so that the collaborative (air-oven) study could be conducted on an ongoing basis rather than on an *ad hoc* basis. He cautioned that the proposal would have to include corn and wheat as well as soybeans.

At the 2011 NTETC Grain Analyzer Sector meeting, Ms. Johnson, AOCS, proposed an air-oven/GMM proficiency testing series designed specifically to address the needs of GMM manufacturers and states maintaining a grain moisture laboratory. AOCS would administer the program, oversee distribution of samples, compile results, perform statistical analysis of results, and distribute a report to participants. AOCS does not collect the samples. This is subcontracted to suitable providers. AOCS does not have laboratories. Since GIPSA/FGIS is a certified laboratory already participating in the AOCS Soybean Quality Traits program, GIPSA air-oven results could be reported for comparison.

At the Sector's August 2012 meeting, the Sector learned that Ms. Christine Atkinson will be taking over the Proficiency Testing program for states and interested manufacturers formerly headed by Ms. Amy Johnson. Ms. Atkinson verified that participant's cost will remain \$100 per year. The Sector reiterated that the program should focus solely on the standard FGIS air-oven method. Instrument results will not be reported. Participants' air-oven results will be compared against GIPSA's standard FGIS air-oven results. In response to Ms. Atkinson's question about scheduling, the Sector was in general agreement that samples should ship after harvest, preferably between mid-January and mid-February with participants' results due 30 days after the shipping date.

The Sector agreed upon the following program details:

Samples – Soybeans 2, Corn 2, Hard Red Winter Wheat 2

- Cost to Participants – \$100.00/year
- Schedule:
  - Samples (6) ship between January 15 and February 15.
  - Samples must be tested within five-business days of receipt with results due 30 days after the shipping date.
- Reports to be posted on [www.SoybeanQualityTraits.org](http://www.SoybeanQualityTraits.org) by 1 May.
- Only the GIPSA oven results will be identified. Individual manufacturer's and state participant's oven results will be assigned an identifier known only to the manufacturer or state participant. Instrument results will not be reported.
- Detailed Participant Instructions will be provided to each participant.

At the August 2013 Grain Analyzer Sector meeting, no report was provided on AOAC's efforts to conduct proficiency testing for grain moisture. Mr. Karl Cunningham (Illinois) and Kevin Hanson (Missouri) agreed to work together to conduct a grain moisture proficiency test. Mr. Cunningham agreed to provide the samples for proficiency testing and Mr. Hanson agreed to analyze the data in accordance with the procedures used to conduct proficiency testing in the state laboratory program. Mr. Hanson also agreed to collect data on test weight per bushel, which may be useful in field test procedures for evaluating test weight per bushel on instruments. Following the August 2013 Sector meeting, arrangements were made for shipping grain samples to state participants.

At the August 2014 Grain Analyzer Sector meeting, Mr. Cunningham provide an update on the status of proficiency testing. Mr. Cunningham informed the Grain Analyzer Sector that he collected some wheat grain samples, which can be used for grain moisture proficiency testing, and that corn and soybeans will be collected during the 2014 harvest. Mr. Cunningham noted that after January 2015 wheat, corn, and soybeans grain samples may be ready for distribution to the participating states. Mr. Cunningham agreed to analyze the data in cooperation with NIST and requested a list of contact information for participating states and other interested parties.

## 12. The Feasibility of a Phase II program for Near Infrared Grain Analyzers

### Source:

Dr. Hurburgh, Iowa State University

### Background/Discussion:

The GIPSA Grain Inspection Advisory Committee recommends that GIPSA initiate research to determine the feasibility of extending the theory of “equivalency” to multiple-constituent instruments in order to utilize standardized technology while maintaining accuracy and consistency in measurement of wheat protein.

Ms. Eigenmann provided an update on the Grain Inspection Advisory Committee’s Resolutions. The Sector discuss the feasibility of an ongoing calibration program also referred to as a Phase II program for Near Infrared Grain Analyzers (NIR) instruments that measure wheat program. The Phase II program for grain moisture is a program that monitors the moisture calibrations on grain moisture meters annually. As changes to the calibrations occur due to grains, climate, etc., data collected in this program allows for changes to moisture calibrations annually and ensure equivalency among the different moisture meter models. The Advisory committee is recommending that this program be extended to include NIR instruments that measure wheat protein. It was noted that there could be multiple NIR instruments for wheat protein introduced into the market and that it may be advisable to have the Phase II program extended to NIR instruments that measure wheat protein. It was also mentioned that currently there are few States that are checking wheat protein on multi-constituent instruments.

GIPSA currently has an annual review program for the official protein system but would have to consider the cost associated with extending the program for other NIR wheat protein analyzers. It was noted during the discussion that GIPSA currently has hourly rate fees set that could be applied to a phase II program for wheat protein.

Unlike moisture where there may be changes to the calibrations annually, there will not be year to year changes for wheat protein. As such, consideration may be given to conducting the program less often than annually, and considering reviewing wheat protein calibrations every 3, 4, or 5 years, as appropriate. In addition it was noted that there also has to be a mechanism to get manufacturers calibration data for calibration review.

The Sector will continue to discuss the feasibility of a phase II program for wheat protein giving consideration to the following issues:

- How the program will be funded;
- How often the calibrations for wheat protein will be updated;
- How many devices are currently being used in commercial transactions; and
- If being used commercially in a State, what is needed by States to begin testing these devices?

At the August 2014 Grain Analyzer Sector meeting, USDA, GIPSA representatives provided an update on the activities concerning a phase II program for wheat protein. The Sector was informed that USDA, GIPSA is discussing funding options for this program. It was noted that the frequency of calibration for wheat protein is being considered and that this will impact the cost of the program. The Sector was also informed that Dr. David Funk is writing a discussion paper that will address many of the issues concerning a Phase II program for wheat protein.

## 13. Next Sector Meeting

The next meeting is tentatively planned for Wednesday, August 19 and Thursday, August 20, 2015, at the Chase Suites by Woodfin at KCI in Kansas City, Missouri. Sector members are asked to hold these days open pending confirmation of availability of facility, determination of agenda items, exact meeting times, and meeting duration. Final meeting details will be announced by early June 2015.

If you would like to submit an agenda item for the 2015 meeting, please contact any of the following persons by June 1, 2014:

Jim Truex, NTEP Administrator at [jim.truex@ncwm.net](mailto:jim.truex@ncwm.net)

G. Diane Lee, NIST Technical Advisor, at [diane.lee@nist.gov](mailto:diane.lee@nist.gov)

At the August 2014 Grain Analyzer Sector meeting, the Sector discussed the proposed dates and location for the August 2015 Grain Analyzer Sector Meeting. It was noted during the discussion that the Sector may consider holding a web meeting, depending on the number of sector items that are received. Following the August 2014 meeting the NCWM, Inc. posted a list of the 2015 Sector meetings on their web site. The August 2015 Grain Analyzer Sector meeting is scheduled for August 19 - 20, 2015, as a live web meeting.



THIS PAGE INTENTIONALLY LEFT BLANK

## Appendix D

### National Type Evaluation Program (NTEP) Measuring Sector Annual Meeting Summary

#### 2014 FINAL SUMMARY

October 3 - 4, 2014  
Raleigh, North Carolina

#### INTRODUCTION

The charge of the NTETC Measuring Sector (herein after referred to as “Sector”) is to provide appropriate type evaluation criteria based on specifications, tolerances and technical requirements of NIST Handbook 44, *Specifications, Tolerances, and Other Technical Requirements for Weighing and Measuring Devices*, Sections 1.10. General Code and all portions of Section 3 including codes for Liquid Measuring Devices, Vehicle Tanks Meters, Liquid Petroleum Gas and Anhydrous Ammonia Measuring Devices, Cryogenic Liquid Measuring Devices, Milk Meters, Water Meters, Mass Flow Meters, and Carbon Dioxide Liquid Measuring Devices. The Sector’s recommendations are presented to the National Type Evaluation Program (NTEP) Committee each January for approval and inclusion in NCWM Publication 14, *Technical Policy, Checklists, and Test Procedures* for national type evaluation.

The Sector is also called upon occasionally for technical expertise in addressing difficult NIST Handbook 44 issues on the agenda of National Conference on Weights and Measures (NCWM) Specifications and Tolerances (S&T) Committee. Sector membership includes industry, NTEP laboratory representatives, technical advisors, and the NTEP Administrator. Meetings are held annually, or as needed and are open to all NCWM members and other registered parties.

Proposed revisions to the handbook(s) are shown as follows: 1) deleted language is indicated with a **bold face font using strikeouts** (e.g., ~~this report~~), 2) proposed new language is indicated with an **underscored bold faced font** (e.g., new items), and 3) nonretroactive items are identified in *italics*. There are instances where the Sector will use **red** text and/or **highlighted** text to bring emphasis to text that requires additional attention. When used in this report, the term “weight” means “mass.”

**Note:** It is policy to use metric units of measurement in publications; however, recommendations received by NCWM technical committees and regional weights and measures associations have been printed in this publication as submitted. Therefore, the report may contain references to inch-pound units.

**Table A**  
**Table of Contents**

Title of Content	Page NTEP D
<b>DETAIL OF ALL ITEMS .....</b>	<b>3</b>
<b>CARRY-OVER ITEMS:.....</b>	<b>3</b>
1. Add Testing Criteria to NTEP Policy U “Evaluating Electronic Indicators Submitted Separate from a Measuring Element.”.....	3
2. Identification of Certified Software.....	7
3. Software Protection/Security.....	12
4. Software Maintenance and Reconfiguration.....	13
<b>NEW ITEMS: .....</b>	<b>13</b>
5. Recommendations to Update NCWM Publication 14 to Reflect Changes to NIST Handbook 44.....	13
A. N.4.2.4. Wholesale Devices, 2013 NCWM S&T Committee Item 330-3.....	14
B. G-S.5.6. Recorded Representations, 2014 NCWM Item 310-2.....	15
C. S.1.6.7. and S.1.6.8. Recorded Representations NCWM S&T Item 330-1.....	16
D. S.1.5.3. Recorded Representations, Point-of-Sale Systems.....	17
6. Add Instructions to NCWM Publication 14 Field Evaluation and Permanence Tests for Metering Systems, Paragraph B.....	18
7. Eliminate Permanence Testing for Point of Sale (POS) Systems.....	23
8. NIST Handbook 44: Section 3.32. LPG and Anhydrous Ammonia Liquid-Measuring Devices, N.3. Test Drafts; Section 3.37. Mass Flow Meters, N.3. Test Drafts.....	25
<b>ADDITIONAL ITEMS AS TIME ALLOWS: .....</b>	<b>27</b>
9. Appendix D – Definitions: Remote Configuration Capability, NCWM S&T Committee Item 360-2 (D). .....	27
10. N.4.2.5. Initial Verification and UR.2.5.1. Initial Verification Proving Reports, Wholesale Devices; NCWM Item 330-4 (D).....	29
11. N.4.6. Initial Verification and UR.1.5. Initial Verification Proving Reports; NCWM Item 331-1 (D).....	31
12. 3.30. Liquid-Measuring Devices, N.4.1.3. Normal Tests on Wholesale Multi-Point Calibration Devices. ....	32
13. 3.31. Vehicle-Tank Meters, N.4.1.4. Normal Tests on Multi-Point Calibration Devices.....	32
14. Appendix D – Definitions: Calibration Parameter and Multi-Point Calibrated Device.....	33
15. NCWM S&T Item 332-1 D – S.1.4.3. Provisions for Power Loss; S.1.5.1.1. Unit Price; S.1.5.1.2. Product Identity; S.1.6. For Retail Motor Fuel Dispensers Only; S.1.7. For Wholesale Devices Only; UR.2.7. Unit Price and Product Identity; and UR.2.8. Computing Device.....	34
16. Event Logger; Electronic Transfer of Information.....	35
17. S&T Committee Carryover Item 337-2 Equivalent Units for Natural Gas.....	37
<hr/>	
<b>SUB-APPENDICES</b>	
<b>A</b> Checklist for Testing Electronic Digital Indicators– “Clean” Version, Agenda Item 1.....	A1
<b>B</b> Excerpt from 2013 Measuring Sector Summary, SW Maintenance & Reconfiguration, Agenda Item 4. B1	B1
<b>C</b> Applying Permanence Test Criteria – Examples and Testing Requirements, Agenda Item 6.....	C1
<b>D</b> 2014 S&T Item Proposals to Change LPG Code, Agenda Item 15.....	D1

This publication is available free of charge from: <https://doi.org/10.6028/NIST.SP.1210>

**Table B**  
**Glossary of Acronyms**

CC	Certificate of Conformance	OIML	International Organization of Legal Metrology
DMS	Division of Measurement Standards	OWM	Office of Weights and Measures (NIST)
ECR	Electronic Cash Register	PD	Positive Displacement
HB 44	NIST Handbook 44 “Specifications, Tolerances, and Other Technical Requirements for Weighing and Measuring Devices”	Pub. 14	NCWM Publication 14
LMD	Liquid Measuring Devices	RMFD	Retail Motor-Fuel Dispenser
mA	milliamp	SI	International System of Units
NCWM	National Conference on Weights and Measures	S&T	Specifications and Tolerances
NIST	National Institute of Standards and Technology	VTM	Vehicle Tank Meter
NTEP	National Type Evaluation Program	W&M	Weights and Measures
NTETC	National Type Evaluation Technical Committee		

This glossary is meant to assist the reader in the identification of acronyms used in this agenda and does not imply that these terms are used solely to identify these organizations or technical topics.

---



---

**Detail of All Items**  
 (In order of Reference Key)

---

**Carry-over Items:**

**1. Add Testing Criteria to NTEP Policy U “Evaluating Electronic Indicators Submitted Separate from a Measuring Element.”**

**Source:**  
 California NTEP Lab

**Background:**  
 At its 2007 meeting, the Measuring Sector heard that Technical Policy U in NCWM Publication 14 allows for testing an indicator separate from a measuring element. However, specific test criteria had not been developed for this practice. The Sector heard a recommendation to develop and add specific criteria for testing an indicator separate from a measuring element.

From 2007 to 2010, the California NTEP laboratory worked to develop a checklist but received limited input on the drafts. At its 2011 meeting, the Sector agreed that additional work is needed to finalize the checklist and established a work group (WG) to complete this task. Mr. Rich Miller (FMC) volunteered to serve as Chair of the WG and the NIST OWM Sector Technical Advisor. From 2001 to 2012 attempts were made to find an opportunity to test the draft checklist during a type evaluation. In August 2013, Mr. Miller, informed the Technical Advisor that the North Carolina laboratory used the checklist when conducting an evaluation on an FMC’s indicator. During the evaluation,

Mr. Miller and the North Carolina laboratory evaluators reviewed the checklist and identified some suggested areas for revision. At its 2013 meeting, the Measuring Sector concluded that additional work is needed on the draft checklist and agreed to carry this item over to allow the WG to finalize it.

See the 2007 to 2013 NTEP Measuring Sector Meeting Summaries for additional details.

In July 2014, Mr. Clark Cooney (NIST, OWM), Measuring Sector Technical Advisor, spoke with Mr. Rich Miller (FMC) and Mr. Allen Katalinic (North Carolina Weights and Measures) about the progress on this item. Mr. Miller stated he received no additional feedback from any Sector members. He stated that he and Mr. Katalinic used the checklist on an evaluation, and it appeared to work. Mr. Katalinic stated there may still be some portions that need refinement; however, he also believes that it is ready to move forward. Consequently, the Sector was asked to recommend that the draft be added to the next edition of NCWM Publication 14.

**Discussion:**

At its 2014 meeting, the Measuring Sector discussed both this agenda Item 1 and agenda Item 7, titled, *Eliminate Permanence Testing for Point of Sale (POS) Systems*, simultaneously due to the overlap of the two items. Consequently, discussion of both of these items appears under this agenda Item 1.

The Sector was asked to review a draft checklist entitled, *Checklist for testing electronic digital indicators with simulated inputs* and consider recommending it be added to NCWM Publication 14. A “clean” copy (although, it contains notes) of the proposed amendments to the checklist is included in Appendix A, *Draft Checklist for Testing Electronic Digital Indicators*.

Mr. Miller and Mr. Katalinic, both of whom who had used the draft checklist (see Appendix A, *Draft Checklist for Testing Electronic Digital Indicators*), provided an overview and background discussion. They pointed out that this proposed checklist is for NTEP Laboratory evaluations only. In addition, they identified a few items on which they would still like input on from the Measuring Sector members. Some of these items include the following:

- Is permanence testing necessary? They believe if the device is being evaluated for the first time, then permanence testing is necessary. If the device was previously evaluated and is being examined for updates, then it does not need permanence testing.
- In Section “Code Reference: G-S.2. Facilitation of Fraud,” it addresses the process of changing the unit price or unit prices set into a metering system. They believe that other items fall under facilitation of fraud and this needs more input from the Sector. For example, if the device is a Category 3 device, then the evaluator must verify that the passwords and audit trail function correctly. Mr. Katalinic states this is not a laboratory issue but rather a field requirement; due to the fact that the equipment is being lab evaluated, the evaluator will not see the end use installation.
- In Section “Code Reference: G-S.4. Interchange or Reversal of Parts, paragraph 1.15.,” they noted that there may be a need to add a NIST Handbook 44 requirement to cover this.
- In Section, “Code Reference: G-S.5.1. Indicating and Recording Elements, paragraph 2.1.5.,” they noted that a comment section is needed.
- In Section, “Code Reference: G-S.5.2.5. Permanence, paragraph 2.18.,” they need to know what permanence quantities the Sector believes should be verified for electronic devices with graphic displays.
- In Section, “Code Reference: G-UR.1.1. Suitability of Equipment,” titled, *The equipment is suitable for its intended application*, should the checklist item title be removed?
- In the table, “*Simulator tests: All tests shall have a minimum of 10,000 pulses applied to the device for each test. Test with a minimum of two API/Density settings,*” they note the following items need to be added to the table and checklist:

- information needs to be added to capture different K-Factor values;
- all API tables to be included on the certificate shall be verified; and
- extreme endpoints and a center point of each table must be verified.

The Measuring Sector discussed whether or not the checklist is even necessary and suggested that the concerns might be resolved in other ways.

There was much discussion and debate about the proposed amendments to the draft checklist and whether or not permanence tests were necessary in certain applications.

Mr. John Roach (CDFA DMS) stated that he is amenable to eliminating the permanence test requirements if the unit is in a stationary application. However, if it is in a mobile application, then he strongly believes that a permanence test in the field is required. Mr. Randy Moses (Wayne) stated that if he installs a system in San Diego, for example, his electronic is not going to fail. In response, Mr. Mike Keilty (Endress + Hauser) stated that the equipment could be subjected to the most extreme conditions as well.

Mr. Jim Truex (NTEP Director) pointed out that if there is an update to a Certificate of Conformance (CC), then NTEP makes the decision if a permanence test is required or not.

During the discussion, the NTEP laboratories represented at the meeting expressed frustration with having to duplicate efforts in different sections of NCWM Publication 14 plus running the risk of overlooking requirements in other sections. Mr. Miller thought that the purpose was to have one checklist with all of the requirements that apply to electronic indicators in one place. Mr. Roach stated that he has to print out and cover the General Section for every evaluation and repeating information from the General in this checklist. Mr. Rich Tucker (RL Tucker LLC) stated that he agrees with the laboratories; if requirements are in the checklist already, it does not make sense to duplicate it.

Mrs. Tina Butcher (NIST, OWM) suggested addressing this in the Permanence Testing for POS item on this agenda. This would require matching up Policy U and the Field Evaluation portion of the Checklist (see Item 7). The Sector supported Mrs. Butcher's suggestion of developing an alternative proposal.

In conjunction with this item, the Sector also discussed agenda Item 7, titled, "*Eliminate Permanence Testing for Point of Sale (POS) Systems.*"

Mr. Miller stated OIML conducts additional testing beyond what is required in the United States. For example, OIML R 117 requires testing for environmental, RFI, immunity, vibration, and other influences to help ensure the devices will perform appropriately in actual applications. However, it does not require permanence testing. It was noted the United States does not have the same requirements as OIML R 117. If the device is new and undergoing NTEP evaluation for the first time, then a permanence test is required in the field. But, if the changes are for minor updating, then a permanence test is not required. Mr. John Roach (CDFA DMS) stated his opinion that the permanence test may be eliminated if the NTEP CC is simply being amended or if the device is installed in a stationary location; however, if the device is installed in a mobile application, then it needs to be subjected to permanence testing. Mr. Truex stated it is always up to NTEP to decide if permanence testing is necessary or not.

Based on the discussion, the Sector developed an alternate proposal to amend NCWM Publication 14, LMD *Field Evaluation and Permanence Tests for Metering Systems*, to include both laboratory and field tests for evaluating indicators that have been submitted separate from a measuring element (Sector's agenda Item 1) and to address the concerns for permanence testing (Sector's agenda Item 7).

**Decision:**

The Sector rejected the proposed checklist due to redundancy with other sections of Publication 14 and the belief that the checklist is not necessary. In addition, the Sector rejected the original proposed amendment to NCWM Publication 14, Liquid-Measuring Devices (LMD) checklist, titled, *Field Evaluation and Permanence Tests for Metering Systems – Field Evaluation* (see Sector's agenda Item 7)

However, to resolve the concerns of evaluating electronic indicators and to eliminate permanence testing for point of sale systems, the Sector recommends amending NCWM Publication 14 in three sections:

1. Modify LMD *Technical Policy*, section “U,” titled, *Evaluating Electronic Indicators Submitted Separate from a Measuring Element* as follows:

**U. Evaluating Electronic Indicators Submitted Separate from a Measuring Element**

When evaluating electronic indicators submitted separate from a measuring element, simulated inputs (e.g., meter pulse, temperature, pressure, density, communications, etc.) may be used as follows:

1. For the initial testing of the indicator.
  2. ~~For the evaluation of stationary indicators.~~
  3. For software changes to a device with an existing CC.
2. Modify the “Introduction” portion of *Electronic Cash Register Interfaced with Retail Motor Fuel Dispenser Checklists and Procedures* as follows:

**Introduction**

This checklist is intended for use when conducting general evaluations of new electronic cash registers (ECR) that are to interface with retail motor fuel dispensers. It is assumed that the dispenser was previously evaluated, if not, the Liquid Measuring Device checklist must be applied to the dispenser sale system. The ECR must interface with a dispenser to perform this evaluation. Specific criteria that apply to service station control consoles are in the checklist for retail motor fuel dispensers and must be applied if the cash register also serves as the service station controller. As a minimum, two dispensers from different manufacturers, each of which includes all of the features to be listed on the ECR Certificate of Conformance (CC), must be evaluated with the ECR in order to have the statement "equivalent and compatible equipment" appear on the CC.

**For field evaluation and permanence test criteria, see the “Field Evaluation” section in the NTEP Liquid-Measuring Devices – Field Evaluation and Permanence Tests for Metering Systems checklist.**

This checklist is designed in a logical sequence for the user to determine and record the conformance of the device with the elements of NIST Handbook 44. The user should make copies of the checklist to serve as worksheets and preserve the original for reference. In most cases, the results of evaluation for each element can be recorded by checking the appropriate response. In some cases, the user is required to record values, results, or comments. In those cases, space is provided.

And,

3. Modify the LMD *Field Evaluation and Permanence Test for Metering Systems* as follows:

National Type Evaluation Program  
Liquid Measuring Devices – **Laboratory/** Field Evaluation and Permanence Tests  
For Metering Systems

**Laboratory or Field Evaluation**

**When evaluating electronic indicators submitted separate from a measuring element, simulated inputs (e.g., meter pulse, temperature, pressure, density, communications, etc.) may be used as follows:**

- **For the initial testing of the indicator.**
- **For software changes to a device with an existing CC.**

Measuring systems, devices, and elements whose performance may change with use over time are generally subject to field evaluation and permanence tests.

The following types of devices and elements are subject to a subsequent field evaluation after the initial field or laboratory evaluation:

- Electronic Indicating Elements
- Consoles
- Recording Elements
- Electronic Cash Registers
- Data Processing Units

Field examination is conducted between 20 and before 30 days of use in a normal installation. During this interval, the device must perform and function correctly and not be serviced. Permanence tests are conducted on equipment such as a complete measuring system or only a measuring element (meter.)

**The permanence test is not required in either new evaluations or updating a CC for the electronic devices listed above in stationary installations. The permanence test for mobile electronic devices may be waived by NTEP for updating a CC.**

## 2. Identification of Certified Software.

### Source:

NTEP Software Sector

### Background:

The Measuring Sector was asked to review and comment on the following updated proposal forwarded from an August 2014 joint Weighing/Software Sector meeting. The Sector was also asked to discuss any alternative proposals from manufacturers on how an inspector can confirm that the software operating in a software-based measuring device is the same as what was evaluated and approved by the NTEP laboratory.

Amend NIST Handbook 44, G-S.1. Identification and G-S.1.1. Location of Marking Information for Not-Built-For-Purpose, Software-Based Devices as follows:

**G-S.1. Identification.** – All equipment, except weights and separate parts necessary to the measurement process but not having any metrological effect, shall be clearly and permanently marked for the purposes of identification with the following information:

- (a) the name, initials, or trademark of the manufacturer or distributor;
- (b) a model identifier that positively identifies the pattern or design of the device;
  - (1) *The model identifier shall be prefaced by the word “Model,” “Type,” or “Pattern.” These terms may be followed by the word “Number” or an abbreviation of that word. The abbreviation for the word “Number” shall, as a minimum, begin with the letter “N” (e.g., No or No.). The abbreviation for the word “Model” shall be “Mod” or “Mod.” Prefix lettering may be initial capitals, all capitals, or all lowercase.*  
[Nonretroactive as of January 1, 2003]  
(Added 2000) (Amended 2001)



- (c) *a nonrepetitive serial number, except for equipment with no moving or electronic component parts and ~~not built for purpose software-based software devices~~ software;*  
*[Nonretroactive as of January 1, 1968]*  
(Amended 2003) **(Amended 20XX)**
- (1) *The serial number shall be prefaced by words, an abbreviation, or a symbol, that clearly identifies the number as the required serial number.*  
*[Nonretroactive as of January 1, 1986]*
- (2) *Abbreviations for the word “Serial” shall, as a minimum, begin with the letter “S,” and abbreviations for the word “Number” shall, as a minimum, begin with the letter “N” (e.g., S/N, SN, Ser. No., and S. No.).*  
*[Nonretroactive as of January 1, 2001]*
- (d) *the current software version or revision identifier for not-built-for-purpose software-based devices; manufactured as of January 1, 2004 through December 31, 2015, and all software based devices or equipment manufactured as of January 1, 2016 2020;*  
*~~[Nonretroactive as of January 1, 2004]~~*  
(Added 2003) **(Amended 20XX)**
- (1) *The version or revision identifier shall be:*
- i. *prefaced by words, an abbreviation, or a symbol, that clearly identifies the number as the required version or revision;*  
*[Nonretroactive as of January 1, 2007]*  
(Added 2006)

**Note: If the equipment is capable of displaying the version or revision identifier but is unable to meet the formatting requirement, through the NTEP type evaluation process, other options may be deemed acceptable and described in the CC.**

- ii. **directly linked to the software itself; and**  
**[Nonretroactive as of January 1, 2016 2020]**  
**(Added 20XX)**
- iii. **continuously displayed\* or be accessible via the display menus. Instructions for displaying the version or revision identifier shall be described in the CC. As an exception, permanently marking the version or revision identifier shall be acceptable providing the device does not have an integral interface to communicate the version or revision identifier.**  
**[Nonretroactive as of January 1, 2016 2020]**  
**(Added 20XX)**
- ~~**\*The version or revision identifier shall be displayed continuously on software based equipment with a digital display manufactured as of January 1, 20XX and all software based equipment with a digital display as of January 1, 20YY.**~~
- (2) *Abbreviations for the word “Version” shall, as a minimum, begin with the letter “V” and may be followed by the word “Number.” Abbreviations for the word “Revision” shall, as a minimum, begin with the letter “R” and may be followed by the word “Number.” The abbreviation for the word “Number” shall, as a minimum, begin with the letter “N” (e.g., No or No.). Prefix lettering may be initial capitals, all capitals, or all lowercase.*  
*[Nonretroactive as of January 1, 2007]*  
(Added 2006)

(e) a National Type Evaluation Program (NTEP) Certificate of Conformance (CC) number or a corresponding CC Addendum Number for devices that have a CC.

**(1)** The CC Number or a corresponding CC Addendum Number shall be prefaced by the terms “NTEP CC,” “CC,” or “Approval.” These terms may be followed by the word “Number” or an abbreviation of that word. The abbreviation for the word “Number” shall, as a minimum, begin with the letter “N” (e.g., No or No.)  
[Nonretroactive as of January 1, 2003]

The required information shall be so located that it is readily observable without the necessity of the disassembly of a part requiring the use of any means separate from the device. (Amended 1985, 1991, 1999, 2000, 2001, 2003, ~~and~~, 2006 ~~and~~ 201X)

**G-S.1.1. Location of Marking Information for Not-Built-For-Purpose ~~AI~~ Software-Based Devices.** – For not-built-for-purpose, software-based devices, either:

(a) The required information in G-S.1. Identification. (a), (b), (d), and (e) shall be permanently marked or continuously displayed on the device; or

(b) The CC Number shall be:

(1) permanently marked on the device;

(2) continuously displayed; or

(3) accessible through an easily recognized menu and, if necessary, a submenu. Examples of menu and submenu identification include, but are not limited to, “Help,” “System Identification,” “G-S.1. Identification,” or “Weights and Measures Identification.”

**Note:** For (b), clear instructions for accessing the information required in G-S.1. (a), (b), and (d) shall be listed on the CC, including information necessary to identify that the software in the device is the same type that was evaluated.

[Nonretroactive as of January 1, 2004]

(Added 2003) (Amended 2006 ~~and~~ 20XX)

The Measuring Sector was asked to consider recommending the following text be added to NCWM Publication 14:

Identification of Certified Software:

**Note:** Manufacturers may choose to separate metrologically significant software from non-metrologically significant software. Separation would allow the revision of the non-metrological portion without the need for further evaluation. In addition, non-metrologically significant software may be updated on devices without breaking a seal, if so designed. Separation of software requires that all software modules (programs, subroutines, objects etc.) that perform metrologically significant functions or that contain metrologically significant data domains form the metrologically significant software part of a measuring instrument (device or sub-assembly). If the separation of the software is not possible or needed, then the software is metrologically significant as a whole. The conformity requirement applies to all parts and parts shall be marked according to Section G-S-X.X.

The manufacturer must describe and possibly demonstrate how the version or revision identifier is directly and inseparably linked to the metrologically significant software. Where the version revision identifier is comprised of more than one part, the manufacturer shall describe which portion represents the metrological significant software and which does not.

The Measuring Sector was also asked to review and comment on the following proposed definition developed by the joint Software Sector/Weighing Sector:

**Software Based Device.** – Any device utilizing metrologically significant software.

This item originated as an attempt to answer the question “How does the field inspector know that the software running in a software-based weighing or measuring device is the same software evaluated and approved during an NTEP evaluation?” In previous meetings it was shown that the international community has already addressed this issue through both WELMEC and OIML.

At the 2012 NTETC Software Sector Meeting, there was some discussion as to where the terminology regarding inextricably linking the software version or revision to the software itself belonged. The Software Sector recommended proposed language to add to NCWM Publication 14. The proposed language was thoroughly discussed at the 2013 Measuring Sector meeting and rejected. During that meeting, several manufacturers asked for additional time to consider the proposal and carry it back to their respective companies’ software engineers for input. The Sector agreed to carry this item over to its next meeting to allow these manufacturers time to study this issue and bring back alternative(s) to consider. See the 2013 NTEP Measuring Sector Meeting Summaries for additional details.

The Software Sector and the Weighing Sector met in August 2014 to discuss this item. In September 2014, Mr. Truex asked that an alternative proposal for modifications to paragraphs G-S.1. and G.S.1.1 along with a proposed addition to NCWM Publication 14 (both from the joint Software Sector and Weighing Sector meeting in August) be included with the 2014 Measuring Sector agenda for consideration. These proposed changes appear in the proposal above. The two Sectors also noted that the S&T Committee feels a definition is needed for “Software Based Device” and proposed a definition as shown in the proposal above.

The following discussion on this issue at the August 2014 joint Software Sector/Weighing Sector meeting was provided by the Mr. Truex (NTEP Director):

There was concern about using the terminology “manufactured:” in G-S.1.(d). Some manufacturers may still be building old designs.

Mr. Richard Harshman (NIST, OWM) is of the opinion that the S&T Committee will be satisfied with progress we have made during this joint meeting. Mr. Harshman, Mr. Truex, and Mr. Darrell Flocken (NCWM, NTEP) are hopeful that it will become an Informational Item. It likely will not become Voting quite so soon.

Given the new revisions to G-S.1., do any revisions need to be made to G-S.1.1. as written in NIST Handbook 44? If the proposed revisions to G-S.1.1. are implemented, it would relax the requirement to hard-mark the CC on built-for-purpose devices. We should perhaps retain the strike-out of (d) in the proposed revision. If we do not, there will be a conflict in 2020. On the other hand, it may not be an issue. We are currently planning to leave the wording of G-S.1.1. as it stands in NIST Handbook 44.

G-S.1.(d)(i) may create a problem for some exiting built-for-purpose equipment that currently does not preface the version number with “V.” After much discussion, Mr. Jim Pettinato suggested that we craft a note outside of the meeting to address this particular exception (built-for-purpose devices with limited display capability) that can be reviewed on August 28, 2014.

At the end of August 27, 2014, Mr. Scott Henry proposed a change to G-S.1.(d)(i) and G-S.1.(d)(iii) to create a loophole for equipment that has difficulty meeting the display requirements, but is not completely incapable of doing so. We discussed it on August 28, 2014. His suggested wording was problematic, so Mr. Truex suggested, as an alternative, carving out a specific exception along the lines of, “If the device is incapable of prefacing the software version/revision with a “V” or “R,” then NTEP inspectors may agree to allow a different method of indication.”

We are not certain whether the “Note” after G-S.1.(d)(i) regarding corner cases is entirely necessary, but we would like feedback from the S&T Committee whether it is necessary and/or acceptable. This is a requirement that built-

for-purpose software devices previously had not been bound by. Also, you are going to have to go to the CC anyway to find all the details.

**Discussion:** (Note: Due to similarities, Items 2, 3, and 4 were all part of the same discussions.)

On behalf of the Software and Weighing Sectors, Mr. Adam Oldham (Gilbarco, Inc.) who represented the Software Sector to present pertinent information from the joint Software and Weighing Sector meeting in August of this year. Mr. Truex pointed out that NTEP plans to conduct a joint meeting of the Software and Measuring Sectors in October 2015 to continue to develop these software items that are common to all Sectors.

Mr. Oldham's presentation was applicable to the Measuring Sector's agenda Items 2, 3, and 4. Mr. Oldham stated that the Software Sector proposes to amend NCWM Publication 14 and then to subsequently amend NIST Handbook 44 to bring them into concert with one another. Mr. Keilty pointed out it is NIST Handbook 44 that drives NCWM Publication 14, not the other way around. However, Mr. Keilty also noted that some NCWM Publication 14 technical policy amendments cannot always be directly referenced in NIST Handbook 44.

Some Sector members stated it is desirable that the software version number be linked to the actual software application itself. The Sector discussed questions and concerns about separating the metrological from the non-metrological portions of the software. Mrs. Tina Butcher (NIST, OWM) stated that most current software does not separate metrological from non-metrological portions. Mr. Truex stated that the software version number is listed on the NTEP CC and also the CC covers any higher versions.

Concerns were expressed about how inspectors can ensure the software has not been changed in routine field enforcement. Mr. Oldham stated that it will be on the honor system to a degree. If someone alters the software, it will be discovered at some point. Mr. Truex reinforced the point that a lot of trust is placed in the manufacturers to ensure the metrological parameters of the software have not been adversely altered. Mr. Oldham stated manufacturers who deal with international requirements do not have a problem with potential misuse of software and that laboratories may or may not want things changed. Mrs. Butcher reminded everyone that NCWM Publication 14 states a device or software must be designed such that it does not allow an audit trail to be circumvented or cleared out. Mr. Truex agreed this matter is very controversial.

Mr. Randy Moses (Wayne) stated he agrees with this proposal in principle; however, he expressed serious concerns about whether or not anyone really knows what is going on within the software, and its metrological impact on a device. Furthermore, he stated that not requiring the software version (V) be recorded is a major gap in the proposal.

Mr. John Roach (CDFA DMS) stated that he supports the proposal and its overall direction in principle. However, he questioned whether the device manufacturer cannot display the NTEP CC through the software, then how would anyone know to look at the CC? Mr. Truex stated that is where the exception is noted in the NTEP CC and the manufacturer would have to prove the software was in compliance.

Mr. Keilty asked what the Measuring Sector could do to help the NCWM S&T Committee with this item. Mr. Keilty stated he would like this item to move forward as a Voting item at the 2015 NCWM Annual Meeting. However, Mr. Truex stated that it will likely have to go another year before it would be ready for Voting status; however, it may be moved to Informational depending on what the Sector and Regional comments are.

After very thorough discussion of this item, Mr. Rich Miller (FMC) asked the Measuring Sector support this language as proposed. Mr. Roach agreed.

**Decision:**

The Sector agreed to forward a recommendation to the SWMA and the NCWM S&T Committees that the proposal to modify G-S.1. remain an Informational item. The Sector agrees with the general direction of the proposal, but believes additional work is needed before recommending the item for a Vote.

### 3. Software Protection/Security

**Source:**

NTEP Software Sector

**Recommendation:**

The Measuring Sector was asked to discuss and consider the following proposal developed during the August 2014 joint Software Sector and Weighing Sector Meeting.

Add the following new paragraph to Section 1.10. General Code of NIST Handbook 44:

**G-S.9. Metrologically Significant Software Updates. – A software update that changes the metrologically significant software shall be considered a sealable event.**

**[Nonretroactive as of January 2, 20XX]**

**(Added 20XX)**

The Measuring Sector was also asked to discuss any alternative proposals from manufacturers to develop a checklist for NCWM Publication 14 on evaluating software protection and security.

**Background:**

A draft checklist was proposed for NCWM Publication 14 to evaluate the protection and security of software. At the 2013 Measuring Sector meeting, the proposal was thoroughly discussed and debated. The Sector rejected the proposal; however, manufacturers committed to studying the issue and bringing back alternative(s) to consider at the 2014 Sector meeting. **See the 2013 NTEP Measuring Sector Meeting Summaries for additional details.**

The Software Sector and the Weighing Sector discussed this item in a joint meeting on August 27, 2014. In September 2014, Mr. Truex forwarded a recommendation from the joint Software Sector/Weighing Sector meeting to add a new section to NIST Handbook 44 as shown in the “Recommendation” above.

**Discussion:**

At its 2014 meeting, the NTEP Measuring Sector heard many comments on this proposed amendment to add a new paragraph G-S.9. to NIST Handbook 44. Much of the discussion was on the checklist that had been reviewed and rejected by the Measuring Sector at their 2013 meeting.

Mr. Roach (CDFA DMS), Mr. Miller (FMC), and Mr. Keilty (Endress+Hauser Flowtec AG) all stated that they support this proposed amendment. In addition, Mr. Keilty stated he would like to see sealable parameters added to the measuring device portion of NCWM Publication 14 and to recommend the same thing to the other NTEP Sectors.

There was discussion to add language to NIST Handbook 44, General Code, *G-S.8. Provision for Sealing Electronic Adjustable Components*, to further address security concerns; however, there was not a consensus on specific language to propose. Mr. Oldham (Gilbarco, Inc.) stated the Software Sector debated this for at least six hours, and they are still struggling with it.

There was much discussion and vigorous debate on this proposed new paragraph. There was not agreement on what was a metrologically significant change to the software and what was simply an update. It was not clear how this proposal would apply to software that does not currently separate metrologically significant and non-metrologically significant portions within itself. The Measuring Sector also discussed that this be added to the list of sealable parameters, but was advised that the Software Sector does not view a software update as a sealable “parameter” or a “feature.” The Measuring Sector is amenable to adding this to the table but recognized concerns about the terminology.

**Decision:**

The Measuring Sector did not reach a consensus on this proposal. The Sector believes this item needs additional work and clarity on how it would be applied. The Sector also believes this comment needs to be passed onto the Software Sector and the S&T Committee for further review and Development.

#### 4. Software Maintenance and Reconfiguration

**Source:**

NTEP Software Sector

**Recommendation:**

The Measuring Sector was asked to discuss any alternative proposal(s) from manufactures to add language into NCWM Publication 14 on how to secure their software.

**Background/Discussion:**

The Software Sector posed the following question to the Measuring Sector, “After the software is completed, what do the manufacturers use to secure their software?” At the 2013 Measuring Sector meeting, proposals were discussed and debated to address this issue. The Sector rejected the proposals; however, manufacturers committed to studying the issue and bringing back alternative(s) to the 2014 Sector meeting. (See Appendix B for the proposals that were discussed at the 2013 Measuring Sector meeting. Also see the 2013 NTEP Measuring Sector meeting summaries for additional details. See Appendix B for the proposals that were discussed at the 2013 Measuring Sector meeting summaries for details.)

In July 2014, Mr. Jim Truex (NTEP Director) reported he had not received any new information on this issue.

**Discussion:**

At its 2014 meeting, the Measuring Sector discussed this item and reviewed Appendix B; *NTEP Measuring Sector 2014 Agenda, Software Maintenance and Reconfiguration, Excerpts from 2013 Measuring Sector Summary*. However, no alternatives were brought forth, nor were there any alternatives provided by the Software Sector.

The Measuring Sector noted that the information included in Appendix B is basically what is covered in OIML D 31.

Mr. Oldham (Gilbarco, Inc.) stated that portions of this were discussed at the August 2014 Software Sector meeting but not as an entire unit. Mr. Truex stated there were many comments made at the Software Sector meeting including those from Mr. Ambler Thompson (NIST, OWM). This proposed language be added into G-S.8., and from Mr. Rick Harshman (NIST, OWM) who suggested it be added as a new G-S.9.

Mr. Rich Tucker (RL Tucker Consulting, LLC) stated that it sounds like the Measuring Sector’s Item 3 is to address software changes in the field whereas this agenda item (Item 4) is to address changes made at the manufacturer’s facility. He noted this agenda item includes all of the checking and verification to assure that the changes were implemented the way in which they were intended. Mr. Oldham stated the procedures in this item go through the process of what happens behind the scenes when software is upgraded or changed.

**Decision:**

The Sector did not have any additional input and did not provide any recommendations for further action on this issue

**New Items:**

#### 5. Recommendations to Update NCWM Publication 14 to Reflect Changes to NIST Handbook 44.

**Background:**

The 99<sup>th</sup> National Conference on Weights and Measures (NCWM) adopted the following items that will be reflected in the 2015 Edition of NIST Handbook 44 and NCWM Publication 14. These items were included on the Sector’s agenda to inform the Measuring Sector of the NCWM actions and recommend changes to NCWM Publication 14.

**Source:**

NCWM S&T Committee

**A. N.4.2.4. Wholesale Devices, 2013 NCWM S&T Committee Item 330-3.**

At the 2014 NCWM Annual Meeting, NIST Handbook 44, LMD Code, paragraph N.4.2.4. was amended as follows:

**N.4.2.4. Wholesale Devices.** – “Special” tests shall be made to develop the operating characteristics of a measuring system and any special associated or attached elements and accessories. “Special” tests shall include a test at or slightly above the slower of the following rates:

- (a) 20 % of the marked maximum discharge rate; or
- (b) the minimum discharge rate marked on the device.

**In no case shall the test be performed at a flow rate less than the minimum discharge rate marked on the device.**

**(Amended 20XX)**

**Recommendation:**

The Measuring Sector was asked to review and, if acceptable, recommend to the NTEP Committee adoption of the following changes to NCWM Publication 14, Field Evaluation and Permanence Tests for Metering Systems, based upon changes to NIST Handbook 44:

**D. Initial Evaluation and Permanence Tests for Wholesale Positive Displacement (PD) Meters**

The following tests are considered to be appropriate for metering systems on Wholesale PD Meters:

1. Four test drafts at each of five flow rates.

**1.1. “Special” tests shall include a test at or slightly above the slower of the following rates:**

**1.1.1. 20 % of the marked maximum discharge rate; or**

**1.1.2. The minimum discharge rate marked on the device.**

**In no case shall the test be performed at a flow rate less than the minimum discharge rate marked on the device.**

2. Only one meter is required for the initial test; after which, the meter will be reevaluated for permanence. The minimum throughput criterion for these meters is the maximum rated flow in units per minute × 2000.
3. Following the period of use, the tests listed above are to be repeated. All results within the range of flow rates to be included on the Certificate of Conformance (CC) must be within the applicable tolerances. Extended flow range testing performed at the manufacturer's discretion may be included on the CC provided the results are within the acceptable tolerances.

**Technical Advisor’s Note:** At the 2014 NCWM Annual Meeting, the S&T Committee heard comments from Mr. Dmitri Karimov (Liquid Controls) that the phrase, “slightly above” is ambiguous and suggested that the phrase be replaced with similar language to that contained in Measurement Canada’s Bulletin V-03 (rev. 4), Section 4.5.3. Slow Flow Rate shown below.

**4.5.3. Slow Flow Rate:** The slow flow test is performed at a flow rate greater than the minimum rated flow rate of the meter. To ensure the rate is above the minimum, the target flow rate should be determined by summing the following:

- For all meters other than dispensers and refuellers

(Minimum Approved Flow Rate) + (10 % of Minimum Approved Flow Rate)

The Technical Advisor suggested that the Measuring Sector also discuss whether or not more specific guidance is needed during type evaluation.

**Discussion:**

At the 2014 Sector meeting, the Technical Advisor discussed this item. Mt. Clark Cooney (NIST, OWM) reviewed this new amendment to NIST Handbook 44 and the associated proposed change to Publication 14 with the Sector.

At the 2014 Sector meeting, Mr. Truex stated that this NIST Handbook 44 amendment must be recognized in NCWM Publication 14.

Mr. Karimov stated that the Measurement Canada regulation referenced above is applicable to “all meters other than dispensers and refuellers” and suggested this language could be used.

Mr. Karimov questioned how this proposal applies to turbine meters. Mrs. Butcher (NIST, OWM) commented that Mr. Karimov makes a good point and that this also needs to be addressed in NCWM Publication 14, LMD Part H, *Field Evaluation and Permanence Test for Turbine Meters*.

**Decision:** The 2014 Measuring Sector agreed to recommend the language in the “Recommendation” above be added to NCWM Publication 14, LMD *Field Evaluation and Permanence Tests for Metering Systems*, in both Parts D and H, to reflect the corresponding amendments in the 2015 NIST Handbook 44. However, the Sector does not believe more specific language, such as that in Measurement Canada’s Bulletin V-03 (rev. 4), Section 4.5.3. Slow Flow Rate, is necessary and it decided to not recommend it.

**B. G-S.5.6. Recorded Representations, 2014 NCWM Item 310-2**

At the 2014 NCWM Annual Meeting, NIST Handbook 44 General Code was amended as follows:

**G-S.5. Indicating and Recording Elements.**

**G-S.5.6. Recorded Representations.** – Insofar as they are appropriate, the requirements for indicating and recording elements shall also apply to recorded representations. All recorded values shall be printed digitally. **In applications where recorded representations are required, the customer may be given the option of not receiving the recorded representation. For systems equipped with the capability of issuing an electronic receipt, ticket, or other recorded representation, the customer may be given the option to receive any required information electronically (e.g., via cell phone, computer, etc.) in lieu of or in addition to a hard copy.**

(Amended 1975 and 2014)

**Recommendation:**

The Measuring Sector was asked to review and, if acceptable, recommend the following changes be included in NCWM Publication 14, Checklists and Test Procedures:

**Code Reference: G-S.5.6. Recorded Representations**

- 2.10. All recorded values shall be digital. *See also G-UR.3.3.*  Yes  No  N/A
- 2.11. In applications where recorded representations are required, the customer may be given the option of not receiving the recorded representation.  Yes  No  N/A
- 2.12. For systems equipped with the capability of issuing an electronic receipt, ticket, or other recorded representations, the customer may be given the option to receive any required information electronically (e.g., via cell phone, computer, etc.) in lieu of or in addition to a hard copy.  Yes  No  N/A

The electronic copy is provided:



- 2.12.1. In lieu of a hard copy of the recorded representation.  Yes  No  N/A
- 2.12.2. In addition to a hard copy of the recorded representation.  Yes  No  N/A
- Describe the options provided:
- 2.12.3. Via Cell phone.  Yes  No  N/A
- 2.12.4. Computer.  Yes  No  N/A
- 2.12.5. Other (describe).  Yes  No  N/A

(Renumber the subsequent paragraphs.)

**Discussion:** Mr. Cooney and Mrs. Butcher stated that the reference described above already exists in NCWM Publication 14, but this proposal adds additional criteria to reflect the new amendments to NIST Handbook 44, G-S.5.6. Mr. Truex (NTEP Director) stated that an immense amount of work was done to amend NIST Handbook 44, LMD S.1.6.7. and S.1.6.8., a couple of years ago and that the Sector does not want to lose this.

The NTEP Laboratories represented at the 2014 Measuring Sector supported having the checklist only in the General Section so that they do not have to complete the same review in multiple locations within NCWM Publication 14.

The Sector pointed out that in the opening sentence for paragraphs 2.12.1. and 2.12.2., the word, “hard”, needs to be amended to, “electronic.” This amendment was made during the meeting and shows correctly in this copy of the agenda.

**Decision:**

The 2014 NTEP Measuring Sector agreed to propose that NCWM Publication 14 be modified as shown in the “Recommendation” above. Furthermore, the Sector agreed to retain the language in NCWM Publication 14 checklist that pertain to Code References S.1.6.7. and S.1.6.8. because it does not conflict with G-S.5.6.

**C. S.1.6.7. and S.1.6.8. Recorded Representations NCWM S&T Item 330-1.**

At the 2014 NCWM Annual Meeting, NIST Handbook 44, Liquid-Measuring Devices code was amended as follows:

**S.1.6.7. Recorded Representations.** – Except for fleet sales and other price contract sales and for transactions where a post-delivery discount is provided, a printed receipt providing the following information shall be available through a built-in or separate recording element for all transactions conducted with point-of-sale systems or devices activated by debit cards, credit cards, and/or cash:

- (a) the total volume of the delivery;
- (b) the unit price;
- (c) the total computed price; and
- (d) the product identity by name, symbol, abbreviation, or code number.

~~For systems equipped with the capability to issue an electronic receipt, the customer may be given the option to receive the receipt electronically (e.g., via cell phone, computer, etc.)~~

~~[Nonretroactive as of January 1, 1986]~~

(Added 1985) (Amended 1997, 2012, and 2014)

and,

**S.1.6.8. Recorded Representations for Transactions Where a Post-Delivery Discount(s) is Provided.** – Except for fleet sales and other price contract sales, a printed receipt providing the following

information shall be available through a built-in or separate recording element that is part of the system for transactions involving a post-delivery discount:

- (a) the product identity by name, symbol, abbreviation, or code number;
- (b) transaction information as shown on the dispenser at the end of the delivery and prior to any post-delivery discount(s), including the:
  - (1) total volume of the delivery;
  - (2) unit price; and
  - (3) total computed price of the fuel sale.
- (c) an itemization of the post-delivery discounts to the unit price; and
- (d) the final total price of the fuel sale after all post-delivery discounts are applied.

~~For systems equipped with the capability to issue an electronic receipt, the customer may be given the option to receive the receipt electronically (e.g., via cell phone, computer, etc.).~~

(Added 2012) (Amended 2014)

**Recommendation:**

The Measuring Sector was asked to review and, if acceptable, recommend to the NTEP Committee adoption of the following changes to NCWM Publication 14, Checklists and Test Procedures for Retail Motor Fuel Dispensers, based upon changes to NIST Handbook 44:

**Code References: S.1.6.7. Recorded Representations and S.1.6.8. Recorded Representations for Transaction Where a Post-Delivery Discount(s) is Provided.**

Except for fleet sales and other price contract sales, for transactions conducted with point-of-sale systems or devices activated by credit cards, debit cards, or cash, a printed receipt containing information about the transaction shall be available to the customer as outlined in the following items. A printed receipt must always be available to the customer upon request and printing of the receipt may be initiated at the option of the customer. In addition, some systems may be equipped with the capability to issue an electronic receipt; for those systems, the customer may be given the option to receive the receipt electronically (e.g., via cell phone, computer, etc.). See also NCWM Publication 14, Code Reference: G-S.5.6. Recorded Representations.

**Discussion:**

Mr. Truex stated that this language also needs to be added to the “cash acceptors” checklist and other places where S.1.6.7. and S.1.6.8. are referenced.

**Decision:**

The Sector agreed to recommend NCWM Publication 14 be modified as shown in the “Recommendation” above.

**D. S.1.5.3. Recorded Representations, Point-of-Sale Systems.**

At the 2014 NCWM Annual Meeting, NIST Handbook 44, Liquefied Petroleum Gas and Anhydrous Ammonia Liquid-Measuring Devices code was amended as follows:

**S.1.5.3. Recorded Representations, Point-of-Sale Systems. – Except for fleet sales and other price contract sales, a printed receipt providing the following information shall be available through a built-in**

**or separate recording element for all transactions conducted with point-of-sale systems or devices activated by debit cards, credit cards, and/or cash:**

- (a) the total volume of the delivery;**
- (b) the unit price;**
- (c) the total computed price; and**
- (d) the product identity by name, symbol, abbreviation, or code number.**

**Recommendation:**

The Measuring Sector was asked to review and, if acceptable, recommend to the NTEP Committee adoption of the following changes to NCWM Publication 14, Checklists and Test Procedures for Liquefied Petroleum Gas (LPG) Liquid-Measuring Devices, based upon changes to NIST Handbook 44:

**Code Reference: S.1.5.3. Recorded Representations, Point-of-Sale Systems**

**28.13. A printed receipt providing the following information is available through a built-in or separate recording element for all transactions conducted with point-of-sale systems or devices activated by debit cards, credit cards, and/or cash. This does not apply to fleet sales and other price contract sales.**

Yes  No  N/A

**28.13.1. The total volume of the delivery printed.**

Yes  No  N/A

**28.13.2. The unit price printed.**

Yes  No  N/A

**28.13.3. The total computed price printed.**

Yes  No  N/A

**28.13.4. The product identity by name, symbol, abbreviation, or code number.**

Yes  No  N/A

Renumber the subsequent paragraphs.

**Discussion:**

The Sector briefly discussed this item; however, there were very few comments.

**Decision:**

The Sector agreed to recommend that NCWM Publication 14 be modified as shown in the “Recommendation” above.

**6. Add Instructions to NCWM Publication 14 Field Evaluation and Permanence Tests for Metering Systems, Paragraph B.**

**Source:**

Mr. John Roach, California Department of Food and Agriculture (CDFA), Division of Measurement Standards (DMS).

**Recommendation:**

The Sector was asked to consider the following changes to NCWM Publication 14:

Modify Section E of the Technical Policy in the Liquid-Measuring Devices Checklist as follows:

**E. Meter Sizes to be Included on a Certificate of Conformance (CC)**

Based upon the test of a meter (or meters), meters larger and smaller than the meter(s) tested and meeting the following criteria may be covered by the CC:

1. Meter sizes with rated maximum flow rates of 50 % to 200 % of the rated maximum flow rate of the meter tested; and
2. Meter sizes with rated minimum flow rates of 50 % to 200 % of the rated minimum flow rate of the meter tested.
3. The maximum flow rate achieved in an installation is considered to be 80 % of the maximum flow rate to be listed on the CC.

**In order to include additional meter sizes (on a new CC or a CC including previously evaluated meters) beyond these ranges, additional testing, including permanence testing, is required.**

Modify the following sections of the “Field Evaluation and Permanence Testing for Metering Systems” portion of the Liquid-Measuring Devices Checklist as follows:

**A. Field Evaluation and Permanence Test of New-Design Meters in Retail Motor Fuel Dispensers.**

All new-design meters are subject to a permanence test. If a meter is the same as one in a previously tested dispenser, a permanence test is not required. NTEP National Type Evaluation Program reserves the right to require a permanence test based on the result of the initial examination.

...

**Subsequent Examination**

Following the period of use, the tests listed above are to be repeated. All results within the range of flow rates to be included on the Certificate of Conformance (CC) must be within the applicable tolerances. Extended flow range testing performed at the manufacturer's discretion may be included on the CC provided the results are within the acceptable tolerances **for both the initial and subsequent portion of the permanence test. See also Technical Policy Section E “Meter Sizes to be Included on a Certificate of Conformance (CC)” for requirements regarding the inclusion of additional meter sizes and flow rates.**

**B. Field Evaluation Test of Previously Evaluated Components in ~~Retail Motor Fuel Dispensers~~ Metering Systems Using Different Previously Evaluated Meters.**

**Different Previously Evaluated Meter**

Previously evaluated dispensers using a previously type evaluated meter and indicator (register) will be subject to **an** initial test. Based on the test results of the initial test, National Type Evaluation Program (NTEP) may require a permanence test.

**In order to include additional meter sizes and/or flow rates for a system that uses a previously evaluated meter beyond the ranges listed on the original CC for the meter, additional testing, including permanence testing, is required.**

#### **Non-metrological Changes**

A technical administrative review shall be conducted to issue a new Certificate of Conformance (CC) or amend an existing CC for previously evaluated devices because of non-metrological changes. Based on the results of the technical administrative review, NTEP may require additional tests.

#### **C. Field Evaluation and Permanence Test for Vehicle-Tank; Except for LPG, Cryogenic and CO2 Meters.**

...

Following the period of use, the tests listed above are to be repeated. All results within the range of flow rates to be included on the Certificate of Conformance (CC) must be within the applicable tolerances. Extended flow range testing performed at the manufacturer's discretion may be included on the CC provided the results are within the acceptable **tolerances for both the initial and subsequent portion of the permanence test. See also Technical Policy Section E “Meter Sizes to be Included on a Certificate of Conformance (CC)” for requirements regarding the inclusion of additional meter sizes and flow rates.**

#### **D. Initial Evaluation and Permanence Tests for Wholesale Positive Displacement (PD) Meters.**

The following tests are considered to be appropriate for metering systems on Wholesale PD Meters:

1. Four test drafts at each of five flow rates.
2. Only one meter is required for the initial test, after which the meter will be reevaluated for permanence. The minimum throughput criterion for these meters is the maximum rated flow in units per minute  $\times$  2000.
3. Following the period of use, the tests listed above are to be repeated. All results within the range of flow rates to be included on the Certificate of Conformance (CC) must be within the applicable tolerances. Extended flow range testing performed at the manufacturer's discretion may be included on the CC provided the results are within the acceptable tolerances **for both the initial and subsequent portion of the permanence test. See also Technical Policy Section E “Meter Sizes to be Included on a Certificate of Conformance (CC)” for requirements regarding the inclusion of additional meter sizes and flow rates.**

#### **E. Field Evaluation and Permanence Test for LPG and Cryogenic Meters.**

...

Following the period of use, the tests listed above are to be repeated. All results within the range of flow rates to be included on the Certificate of Conformance (CC) must be within the applicable tolerances. Extended flow range testing performed at the manufacturer's discretion may be included on the CC provided the results are within the acceptable tolerances **for both the initial and subsequent portion of the permanence test. See also Technical Policy Section E “Meter Sizes to be Included on a Certificate of Conformance (CC)” for requirements regarding the inclusion of additional meter sizes and flow rates.**

#### **F. Field Evaluation and Permanence Test for LPG Vapor Meters.**

...

Following the period of use, the tests listed above are to be repeated. All results within the range of flow rates to be included on the Certificate of Conformance (CC) must be within the applicable tolerances. Extended flow range testing performed at the manufacturer's discretion may be included on the CC provided the results are within the acceptable tolerances **for both the initial and subsequent portion of the permanence test. See also Technical Policy Section E “Meter Sizes to be Included on a Certificate of Conformance (CC)” for requirements regarding the inclusion of additional meter sizes and flow rates.**

#### H. Field Evaluation and Permanence Test for Turbine Meters.

...

Following the period of use, the tests listed above are to be repeated. All results within the range of flow rates to be included on the Certificate of Conformance (CC) must be within the applicable tolerances. Extended flow range testing performed at the manufacturers" discretion may be included on the CC provided the results are within the acceptable tolerances **for both the initial and subsequent portion of the permanence test. See also Technical Policy Section E “Meter Sizes to be Included on a Certificate of Conformance (CC)” for requirements regarding the inclusion of additional meter sizes and flow rates.** Following evaluation of test data and analysis of the data presented by the manufacturer for meter performance over temperature and viscosity ranges, the evaluating laboratory may require additional testing prior to issuing a CC for the meter.

#### I. Field Evaluation and Permanence Tests for Mass Flow Meters.

...

##### Test Data

...

Following the initial test, the meters will be placed into service for the permanence test. The minimum throughput criterion recommended for these meters are 60 days, or  $2000 \times$  maximum rated flow in units per minute. Following the period of use, the tests listed above are to be repeated. All results within the range of flow rates to be included on the certificate of conformance must be within the applicable tolerances. Extended flow range testing performed at the manufacturer's discretion may be included on the certificate of conformance provided the results are within the acceptable tolerances **for both the initial and subsequent portion of the permanence test. See also Technical Policy Section E “Meter Sizes to be Included on a Certificate of Conformance (CC)” for requirements regarding the inclusion of additional meter sizes and flow rates.**

#### Background:

This item was proposed to ensure that NTEP laboratories are consistent in determining performance and throughput requirements for extending flow rates beyond what is currently approved. Mr. John Roach (CDFA DMS) proposed that instructions be added to NCWM Publication 14 to clarify requirements for extending flow rates for systems that are incorporating a previously approved meter beyond what is currently covered on the NTEP CC for the meter. Mr. Roach provided four examples along with proposed testing requirements; these examples are included in Appendix C.

NCWM Publication 14, Liquid-Measuring Devices Checklist, Technical Policy Section E, “Meter Sizes to be Included on a Certificate of Conformance (CC)”, includes guidance on meter sizes and flow rates that can be included based on testing conducted on a meter. However, it makes no reference to permanence test requirements. The changes in

the “Recommendation” propose including a clear statement in Section E that makes reference to permanence test requirements. Note that Section, “New Product Applications for Meters”, already includes such references.

Criteria for field evaluations, including permanence test criteria, are included in the “Field Evaluation and Permanence Tests for Metering Systems” portion of the checklist, and individual sections within that portion of the checklist may make reference to the “initial” testing and “permanence” testing. Section B. “Field Evaluation Test of Previously Evaluated Components in Retail Motor Fuel Dispensers Using Different Previously Evaluated Meters” provides some guidelines on what testing is required; however, this section does not adequately address some of the scenarios that are being posed to the NTEP Laboratories. Additional guidance is needed to ensure consistency among the NTEP Laboratories and to ensure that manufacturers have a clear understanding of what testing will be required. It is also suggested that the reference to “Retail Motor Fuel Dispensers” be replaced with “Metering Systems” since the principles in this section should be applicable to any metering system.

The following statement is found in multiple sections of the Field Evaluation and Permanence Tests for Metering Systems” section and was added based on Sector action in 2006: “Extended flow range testing performed at the manufacturer’s discretion may be included on the CC provided the results are within the acceptable tolerances.” Because this statement appears as part of the “Subsequent Examination” portion of these sections, questions have been raised about whether or not testing of an extended flow rate only needs to be done during the subsequent portion of the examination in order to cover the extended rates on the CC. To clarify the application of this statement, the Sector is asked to consider adding a statement that this applies to both the initial and subsequent portion of the permanence test and to also add a statement acknowledging additional criteria regarding the addition of flow rates and meter sizes in the Technical Policy section of NCWM Publication 14.

The Sector was also asked to discuss other questions about permanence requirements for mass flow meters relative to other meter technologies. For example, the performance of a positive displacement meter might be affected by repeated use and throughput, which might cause wear and tear on components in the system that can affect accuracy. Is this same premise true of a mass flow meter’s sensor, which has no moving parts? What would the effects be on a fixed orifice meter?

The Technical Advisor suggested the Sector may also wish to consider adding additional text to these sections explaining the need for the holder of the CC for a previously evaluated meter to grant permission for the use of the test results as a means to eliminate permanence testing. While this practice may be well understood from an administrative perspective, a clear statement or reference in the checklist will improve consistency in its application and better understanding of the requirements by manufacturers. While specific language is not suggested in the recommendation, the examples included in the accompanying Appendix C include narrative that could be used.

#### **Discussion:**

The Sector discussed this item at great length and vigorously debated it.

To help them understand the purpose and need for his proposal, Mr. Roach (CDFA DMS) reviewed the examples in the 2014 Sector’s agenda summary Appendix C. He stated that he is getting questioned by manufacturers and he needs clarification in NCWM Publication 14.

A lot of confusion was expressed by the Sector. Some of the questions and comments included:

1. Why is a permanence test needed for electronics?
2. Transmitters cannot be separated from the mass flow meter and still have a functional system.
3. If these were assembled into a retail motor fuel dispenser system, then it would need a full permanence test.

Mr. Rodney Cooper (Tuthill Transfer Systems) spoke at length and carefully described how the transmitter is an integral part of the mass flow meter system. He stated that if the transmitter is changed out, then a new meter has been created and it would need to go through a full permanence test again. Mr. Moses (Wayne) agreed with Mr. Cooper.

The Measuring Sector agreed that if the manufacturer extends the range beyond what the system was originally tested for, then it must go through initial and permanence tests.

The Sector thoroughly discussed the original proposed amendments to NCWM Publication 14 Technical Policy LMD checklist, Section E, “Meter Sizes to be Included on a Certificate of Conformance (CC)” and modifying the sections within “Field Evaluation and Permanence Testing for Metering Systems”, and the examples and proposed test requirements in Appendix C.

**Decision:**

The Sector did not believe the original proposed amendments to NCWM Publication 14 were necessary but it agreed with the test requirements shown in Appendix C (2014 Sector’s Agenda Summary), Examples A and B. However, it made the following amendments and conclusions regarding the application of NCWM Publication 14 to Examples C and D:

- Appendix C; Example C. There must be a full permanence test conducted, not just a 30-day test. If there is not an NTEP Certificate of Conformance (CC) for the meter system using the new transmitter, then the full permanence testing must be conducted. Consequently, the proposed test requirements in Example C need to be amended to reflect this. The changing of the transmitter is metrologically significant and this would be considered a new meter.
- Appendix C; Example D. The conclusion is the same as in Example C above. The change of the transmitter is metrologically significant. If the meter, including the sensor or transmitter, has not been tested as a complete system, then both an initial and permanence test is required.

**7. Eliminate Permanence Testing for Point of Sale (POS) Systems.**

**Source:**

Randy Moses, Wayne Fueling Systems, LLC.

**Background/Recommendation:** The NTEP Measuring Sector was asked to consider the following proposed amendment to the section of the Liquid-Measuring Devices checklist of NCWM Publication 14, titled, *Field Evaluation and Permanence Test for Metering Systems*:

**Field Evaluation**

Measuring systems, devices, and elements whose performance may change with use over time are generally subject to field evaluation and permanence tests.

The following types of devices and elements are subject to a subsequent field evaluation after the initial field or laboratory evaluation:

- Electronic Indicating Elements
- Consoles
- Recording Elements
- ~~Electronic Cash Registers~~
- Data Processing Units

Field examination is conducted between 20 days and before 30 days of use in a normal installation. During this interval, the device must perform and function correctly and not be serviced. Permanence tests are conducted on equipment such as a complete measuring system or only a measuring element (meter.) **Only an initial evaluation is required for Electronic Cash Registers.**



And a proposal to amend NCWM Publication 14, *Electronic Cash Register Interfaced with Retail Motor Fuel Dispenser Checklists and Test Procedures*, “Introduction” section as follows:

### **Introduction**

This checklist is intended for use when conducting general evaluations of new electronic cash registers (ECR) that are to interface with retail motor fuel dispensers. It is assumed that the dispenser was previously evaluated, if not, the Liquid Measuring Device checklist must be applied to the dispenser sale system. The ECR must interface with a dispenser to perform this evaluation. Specific criteria that apply to service station control consoles are in the checklist for retail motor fuel dispensers and must be applied if the cash register also serves as the service station controller. As a minimum, two dispensers from different manufacturers, each of which includes all of the features to be listed on the ECR Certificate of Conformance (CC), must be evaluated with the ECR in order to have the statement "equivalent and compatible equipment" appear on the CC.

### **For field evaluation and permanence test criteria, see the “Field Evaluation” section in the NTEP Liquid-Measuring Devices – Field Evaluation and Permanence Tests for Metering Systems checklist.**

This checklist is designed in a logical sequence for the user to determine and record the conformance of the device with the elements of NIST Handbook 44. The user should make copies of the checklist to serve as worksheets and preserve the original for reference. In most cases, the results of evaluation for each element can be recorded by checking the appropriate response. In some cases, the user is required to record values, results, or comments. In those cases, space is provided.

The submitter of this item states that the 2014 NCWM Publication 14, LMD – *Field Evaluation and Permanence Tests for Metering Systems; Permanence Test Procedures for Meters*, paragraph A; *Field Evaluation and Permanence Test of New-Design Meters in Retail Motor Fuel Dispensers*, currently requires a permanence test to be performed on point of sale (POS) systems. The submitter believes that a permanence test needs to be performed on a device that is subject to wear. However, he believes that wear is not an issue with POS systems, thus, a permanence test should not be required. He acknowledges that there is the possibility that an electronic component may fail, but in this case, the test would be started over. The submitter believes that if that were to happen, it would likely pass the test the second time. He states that the tests should be limited to verifying the proper operation just one time.

In reviewing this item, the Technical Advisor noted that there is no reference to the field evaluation and permanence test criteria in NCWM Publication 14, *Electronic Cash Register Interfaced with Retail Motor Fuel Dispenser Checklists and Test Procedures*. Consequently, the Sector was also asked to consider adding a statement to the “Introduction” section of the, *Electronic Cash Register Interfaced with Retail Motor Fuel Dispenser Checklist and Test Procedures*, checklists as shown in the recommendations.

### **Discussion:**

The Sector discussed both agenda Item 1, *Add Testing Criteria to NTEP Policy U “Evaluating Electronic Indicators Submitted Separate from a Measuring Element”* and this agenda Item 7, *Eliminate Permanence Testing for Point of Sale (POS) Systems*, simultaneously due to the overlap of the two Items. Refer to the Sector’s agenda Item 1 for the discussion on this Item.

### **Decision:**

Since the Sector discussed both agenda Item 1 and Item 7 simultaneously, its decision on this item is recorded in Item 1.

**8. NIST Handbook 44: Section 3.32. LPG and Anhydrous Ammonia Liquid-Measuring Devices, N.3. Test Drafts; Section 3.37. Mass Flow Meters, N.3. Test Drafts.**

**Source:**

Michael Keilty, Endress + Hauser Flowtec AG

**Recommendation:**

The Measuring Sector was asked to discuss and comment on two proposals that have been submitted to the four regional weights and measures associations (CWMA, NEWMA, SWMA, and WWMA). These proposals would amend NIST Handbook 44, LPG and Anhydrous Ammonia Liquid-Measuring Devices and Mass Flow Meters codes, Notes Section, and Test Drafts, to allow transfer standards (master meters) to test and place into service dispensers and flow meters.

**Background/Discussion:**

The submitter of this item, Mr. Mike Keilty (Endress + Hauser Flowtec AG), noted that the use of transfer standards (master meters) are recognized in NIST Handbook 44, Sections 3.34. Cryogenic Liquid-Measuring Devices; 3.38. Carbon Dioxide Liquid-Measuring Devices; and 3.39. Hydrogen Gas-Measuring devices – Tentative Code. He stated that field evaluation of LPG meters, CNG dispensers, and LNG dispensers are very difficult using volumetric and gravimetric field standards and test methods. He also stated that the tolerances for these applications are such that using transfer meter standards are more efficient and safer. In LPG, CNG, and LNG applications, the transfer standard meters are placed in-line with the delivery system as it used to deliver product to tanks and vehicles.

Section 3.37. Mass Flow Meters, UR.3.8. Return of Product to Storage, Retail Compressed Natural Gas Dispensers, requires, in essence, provisions to be made for returning the product to storage or disposing of the product in a safe and timely manner. Mr. Keilty states that: 1) this is difficult to do and most often is not complied with when the test vessel contents are released into the atmosphere; 2) the use of transfer standards eliminates return to storage issues; and 3) the use of transfer standards is easier and faster compared to traditional field standards and the cost of using and transporting transfer standards is much less than that of traditional field provers and standards. Recognition of transfer standards in these particular sections of NIST Handbook 44 will enable states to allow this equipment to place systems into service and for field enforcement.

Mr. Keilty notes that, in some applications, transfer standard meters are not more accurate than the meters being tested and for that reason, longer test drafts and possibly more tests need to be conducted. According to Mr. Keilty, the State of California conducted a short study of master meters in the past, but the conclusion did not lead to wide adoption of the practice. However, he indicates that California uses a mass flow meter as a master meter for carbon dioxide flowmeter enforcement, Colorado uses a master meter to test LPG truck-mounted meters, and Nebraska has used a mass flow meter to test agricultural chemical meters.

The following two proposals to amend NIST Handbook 44, Sections 3.32. LPG and NH<sub>3</sub> and 3.37. Mass Flow Meters have been submitted to the four regional weights and measures associations:

**3.32. Liquefied Petroleum Gas and Anhydrous Ammonia Liquid-Measuring Devices.**

**N.3. Test Drafts.**

**N.3.1. Minimum Test. – Test drafts should be equal to at least the amount delivered by the device in one minute at its normal discharge rate.;**

**N.3.2. Transfer Standard Test. – When comparing a meter with a calibrated transfer standard, the test draft shall be equal to at least the amount delivered by the device in 2 minutes at its maximum discharge rate.**

**(Amended 1982 and 20XX)**

**3.37. Mass Flow Meters.**

### N.3. Test Drafts.

**N.3.1. Minimum Test** – The minimum test shall be one test draft at the maximum flow rate of the installation and one test draft at the minimum flow rate. More tests may be performed at these or other flow rates. (Also see T.3. Repeatability.)

**N.3.2. Transfer Standard Test. – When comparing a meter with a calibrated transfer standard, the test draft shall be equal to at least the amount delivered by the device in two minutes at its maximum discharge rate.**

**(Amended 20XX)**

The submitter also suggested that the S&T Committee might consider amending Section 3.30. Liquid-Measuring Devices and Section 3.31. Vehicle-Tank Meters codes to allow transfer standard meters. However, no formal proposals have been submitted for such changes.

#### **Discussion:**

The Sector thoroughly discussed and vetted this item. There was extensive discussion about the transfer standard (also referred to as a “master meter”) itself, such as:

- The need for the master meter to be a superior standard to the meter being examined;
- Verification procedures including the proper reference weighing device’s capacity and division size;
- The need to maintain control charts on the master meter;
- Frequency of re-verification for the master meter;
- The need to develop NIST Handbook 105 series specifications, test procedures, and tolerances for “master meters;”
- Development of criteria and the ability of the master meter to assure legal traceability; and
- Training staff in the correct use of master meters in field applications; etc.

Some Sector members commented that master meters would resolve many issues currently being faced when testing not only LPG and NH<sub>3</sub> measuring devices, but also measuring devices of various alternative fuels such as compressed natural gas (CNG) and liquefied natural gas (LNG). Such issues include, but are not limited to, multiple steps in measurement by mass, safe handling, and what to do with the product following a test (e.g., compressing it back into storage or venting it into the atmosphere).

The Sector noted that transfer standards (master meters) are allowed in NIST Handbook 44’s Cryogenic, Carbon Dioxide, and Hydrogen Gas (tentative) codes. Mr. Cooney (NIST OWM) pointed out that within each of these codes, there is a more lenient tolerance when using transfer standards. These tolerances are all very similar to each other in that there shall be an amount added to the basic tolerance that is equal to two times the standard deviation of the applicable transfer standard when compared to a basic reference standard.

Ms. Butcher (NIST, OWM) stated that the NIST U.S. National Working Group (USNWG) on alternate test methods (ATMs) was created to evaluate transfer standards; however, much of the work done to this point has been on closed loop provers vs. typical neck type provers. She also pointed out that a draft NIST Handbook 105 for LPG master meters was developed by the National Propane Gas Association (NPGA) and posted for group review, although, she is not aware of any comments received.

Some manufacturers stated that they would like transfer standards (master meters) to be allowed for all measuring device technologies. Mr. Karimov (Liquid Controls) stated that master meter requirements need to be the same across

all measuring device codes equally. Mr. Katalinic (North Carolina Weights and Measures) agreed that it does not matter what technology is used, provided that it meets accuracy and other applicable criteria.

Mr. Moses (Wayne) stated that transfer standards are clearly not as accurate as actually weighing the product on an appropriate weighing device. However, he stated that the reality is that some measuring devices for products such as CNG and LNG are not being tested at all due to the difficulty of current test procedures. He believes that transfer standards are effective in these applications. Ms. Butcher (NIST, OWM) stated that it is time to examine transfer standards as an effective way to test measuring devices of products that are not easily tested or not tested at all. She continued to emphasize that uncertainties, procedures, specifications, legal traceability, and other technical requirements for transfer standards (master meters) must be established first.

Mr. Cooney (NIST, OWM) stated that a comment at the WWMA meeting pointed out the need for master meters and that they would resolve several issues testing meters used to measure certain products. Another comment was heard that the uncertainties of these types of measurements must be fully evaluated prior to adopting any test methods. The WWMA S&T Committee agreed that this technology would more easily facilitate examinations; however, it chose to make this proposal Developmental (D) pending more comprehensive evaluations of the equipment, testing procedures, and uncertainties and to allow more time for the Submitter to provide a more in-depth analysis.

Mr. Cooney suggested that manufacturers of transfer standards (master meters) should work through the NIST USNWG on ATMs to pursue the development of standards and recognition of alternative types of test methods, including transfer standards. This work would include industry conducting research, documenting data, conducting analysis, and sharing this information for review and verification.

**Decision:**

The Sector believes transfer standards are valuable in verifying devices that are not easily tested when used to measure certain products (e.g., CNG and LNG). The Sector supports this item moving forward as a Voting item at the 2015 NCWM Annual Meeting.

**Additional Items as Time Allows:**

If time permits, the NCWM S&T Committee and/or the NTEP Software Sector would appreciate input from the Measuring Sector on the measuring-related issues that are outlined in the remaining agenda items below. A copy of any regional association modifications or positions will be provided to the Sector when these are made available by the regions.

**9. Appendix D – Definitions: Remote Configuration Capability, NCWM S&T Committee Item 360-2 (D).**

**Source:**

2013 NCWM S&T Committee (2012 Grain Analyzer Sector Meeting Summary)

**Recommendation:**

This item was included in the 2014 Measuring Sector agenda to allow the Sector to provide any additional input.

**Background/Discussion:**

At its 2012 meeting, the Grain Analyzer Sector agreed to forward a proposal to amend the definition of “remote configuration capability” in NIST Handbook 44 to the S&T Committee for consideration. The following changes were proposed:

**remote configuration capability.** – The ability to adjust a weighing or measuring device or change its sealable parameters from or through some other device that ~~is not may or may not~~ itself **be** necessary to the operation of the weighing or measuring device or ~~is not may or may not be~~ a permanent part of that device. [2.20, 2.21, 2.24, 3.30, 3.37, 5.56(a)]

(Added 1993, Amended 20XX)

During its Open Hearings at the 2013 NCWM Interim Meeting, the S&T Committee heard comments from NIST, OWM that changes to this definition may affect other types of devices and ever emerging technologies.

Rather than the changes proposed, another option was offered to add onto the current definition of “remote configuration capability” as follows:

**Devices which are programmed using removable media (such as SD cards, flash drives, etc.) that may or may not be required to remain with the device during normal operation are also considered to be remotely configured devices.**

At the 2013 NCWM Annual Meeting, OWM reiterated comments it made at the 2013 Interim Meeting suggesting that it may be appropriate to develop separate requirements to address new and future technologies, which can be remotely configured with removable media. OWM indicated it plans to develop draft language and request input from the various Sectors at their upcoming meetings. Two additional comments were made in support of possibly including requirements in the General Code of NIST Handbook 44 to address newer and emerging technologies.

This item was discussed at the 2013 Measuring Sector meeting and whether or not additional guidance might be needed on what is covered by each sealing category. However, the Sector concluded that the definitions are adequate as currently written.

At the 2014 NCWM Interim Meeting, the SMA indicated that proposed changes for the Grain Analyzer Sector are acceptable. However, the Committee received comments from the Measuring Sector indicating opposition to the proposed language and suggesting that the current definition is adequate. The Committee also heard comments from NIST, OWM expressing concern that the proposed language does not clearly define when a device is considered “remotely configurable.” OWM noted that it is continuing to develop this issue and has approached the various NTEP Sectors for additional input regarding the capabilities of new technology with regard to metrologically significant adjustments. During their 2013 meeting, the Weighing Sector asked its members to assist OWM in identifying the various types of removable storage media used in weighing equipment. The Committee acknowledged comments from OWM expressing concern that the issue be carefully considered to avoid unintentional consequences. The Committee agreed to maintain the Developing status of item in consideration of the ongoing work of OWM to further develop this item.

At the 2014 NCWM Annual Meeting, the S&T Committee heard several comments that this proposal should remain a “Developing Item” and they agreed to keep it designated as such.

NIST, OWM believes that much further development of this item is required and needs to include other remote configuration technologies that may be used in other weighing and measuring devices. NIST OWM does not believe the proposed changes to the definition of “remote configuration capability” are appropriate, but it does not have an alternative to offer at this time. It plans to continue working on this item after the 2014 NCWM Annual Meeting.

Additional background information on NCWM S&T Item 360-2 is contained in the *2014 NCWM Publication 16* and is available at:

<http://www.ncwm.net/resources/dyn/files/1217541z1019c056/ fn/4-ST-Pub16-2014-CORRECTED-06-12-2014.pdf>

**Discussion:**

Mr. Truex stated this item originated from the Grain Analyzer Sector. He stated that not much has happened recently and that it is still developing. Mrs. Butcher (NIST, OWM) stated that she is not aware of any further work or changes to the item.

The Measuring Sector discussed this extensively as to how these devices work and the different categories of devices. Mrs. Butcher stated that all grain analyzers covered by NTEP are Category 3 devices.

**Decision:**

The Sector reiterated its comments from its 2013 meeting and concluded that the definition in NIST Handbook 44 for “remote configuration capability” is adequate as currently written.

**10. N.4.2.5. Initial Verification and UR.2.5.1. Initial Verification Proving Reports, Wholesale Devices; NCWM Item 330-4 (D)**

**Source:**

Minnesota Weights and Measures Division (2014).

**Recommendation:**

This item is included on the Sector’s agenda to make members aware of this proposal to add new paragraphs to NIST Handbook 44, Liquid-Measuring Devices, Notes Section and to ask for input from the Sector on the recommended changes. This item appeared on the 2014 NCWM S&T Committee agenda as a Developing item. NIST OWM is recommending the “Examples” in the proposal are more appropriately included in the EPO’s and training materials rather than in NIST Handbook 44.

**Background/Discussion:**

Ms. Julie Quinn (Minnesota Weights and Measures Division) reported that a group of interested parties has been collaborating to discuss requirements for wholesale meter systems with the capability to be calibrated at different flow rates and for different products.

During the 2014 NCWM Annual Meeting, this group met and developed suggested language to address this issue. Ms. Quinn asked that the S&T Committee include the suggested language in this item for further review and comments by the regional associations and others in the fall. The following language, along with a change to the title of the item (see 2014 NCWM Publication 16), was suggested:

**N.4.2.5. Initial Verification. – A wholesale liquid measuring device shall be tested at all flow rates and with all products for which a calibration factor has been electronically programmed prior to placing it into commercial service for the first time or after being repaired or replaced.**

**A wholesale liquid measuring device not equipped with means to electronically program its flow rates and calibration factors shall be tested at a low and high flow rate with all products delivered prior to placing it into commercial service for the first time or after being repaired or replaced.**

**Example: A meter is electronically programmed to deliver regular and premium gasoline at a startup/shutdown flow rate of 150 gpm, a normal operating flow rate of 650 gpm, and a fall-back rate of 450 gpm. The meter is to be tested with regular gasoline at 150 gpm, 450 gpm and 650 gpm; and with premium gasoline at 150 gpm, 450 gpm and 650 gpm.**

**The official with statutory authority has the discretion to determine the flow rates and products at which a meter will be tested on subsequent verifications.**

**UR.2.5.1. Initial Verification Proving Reports. – Initial verification proving reports for wholesale liquid measuring devices equipped with means to electronically program flow rates shall be attached to and sent with placed-in-service reports when the regulatory agency with statutory authority requires placed-in-service reports.**

Members of this group have agreed to do a presentation at each of the 2014 fall regional meetings to explain this item and other related proposals.

**Discussion:**

The 2014 NTEP Measuring Sector discussed agenda Items 10, 11, 12, 13, and 14 together since they are all closely related and involve multiple point calibration capability. Consequently, the following notes apply to each of the Sector's multiple point calibration agenda items.

Mr. Dmitri Karimov (Liquid Controls) provided a presentation developed by the Multiple Point Calibration Group (MPCG). It is very important to note that this group is *not* officially appointed by the NCWM Board of Directors. This presentation will also be given to all regional weights measures meetings. The purpose of the presentation was to explain the reasoning behind the proposal and to attempt to answer any questions or concerns. The primary objective of the proposal is to linearize the meter's error across its operation, in other words, to flatten the typical error curve that is registered in measuring device.

Mr. Cooney (NIST, OWM) stated that Mr. Doug Deiman (Alaska Weights and Measures) provided the same presentation to the Western Weights and Measurers Association (WWMA) Annual Technical Conference at its September 2014 meeting. Testimony was received at the WWMA that the examples in the proposal need to be removed and perhaps placed into the appropriate NIST Examination Procedure Outline (EPO) or into training materials, but should not be placed into NIST Handbook 44. Mr. Cooney stated that there was significant misunderstanding among the participants at first, but following discussions, they appeared to grasp the concept and supported it. Mr. Cooney stated that the WWMA recommended grouping the related multiple point calibration items together for discussion and status assignment. The WWMA made all of the multiple point calibration proposals Voting Consent (VC) and they all passed.

Mr. Karimov stated that he will be giving this presentation to the 2014 Southern Weights and Measures Association (SWMA) meeting that followed immediately after this Measuring Sector meeting. He stated that he and the MPCG would like the Measuring Sector's support of this and the related proposals and to recommend moving them forward for a Vote at the 2015 NCWM Annual Meeting.

Significant discussion and vigorous debate ensued. Participants from the NTEP laboratories present at this meeting stated that nothing is changed to the applicable tolerances and this would only result in a great amount of additional testing with minimal improvement in the results.

Mr. Luciano Burtini (Measurement Canada) stated that Canada conducts tests at multiple points; however, they do fewer points and leave the choice to the field official. He believes that this proposal could require a lot of time to complete the tests. Mr. Karimov stated that this proposal does not require testing at every point that the device is capable of programming, only for the ones which calibration factors have been entered.

Mrs. Butcher (NIST, OWM) asked Mr. Burtini if they have other criteria in place in their selection process such as the direction of factors. Mr. Burtini responded that yes, they do. Measurement Canada sets a limit on how far apart they can be and the magnitude of the differences.

Mr. Katalinic (North Carolina Weights and Measures) stated that this proposal does not tighten up the tolerances in NIST Handbook 44 and, consequently, will not have any practical effect. In addition, he believes it will cause significant more time for the field official and increased disruption of the businesses for very little improvement in accuracy of the system. He stated that at best, it tightens up the tolerances for the Normal Test but does nothing for the Special Test. He continued that the ramp up and ramp down time for the system is very short. In addition, he uses a 1300 gal prover that is similar in size to typical compartments in a truck and yet he observes a difference of 0.1 %. He stated that he observed very good results in both turbine and positive displacement (PD) meters. He further indicated that loading terminals hold the meters to even tighter tolerances than those published in NIST Handbook 44 and if this proposal requires all of the additional work, then the applicable NIST Handbook 44 tolerances should be reduced.

Some Sector members stated that the existing NIST Handbook 44 Special Test reference in the Notes section of both the LMD and VTM codes currently allow for these additional tests at multiple calibration points to be conducted, thus, there is no need for this proposal.

**Decision:**

The 2014 NTEP Measuring Sector did not reach consensus on this item nor its related Items, 11, 12, 13, and 14. No recommendation was presented from the Sector.

**11. N.4.6. Initial Verification and UR.1.5. Initial Verification Proving Reports; NCWM Item 331-1 (D)**

**Source:**

Minnesota Weights and Measures Division (2014).

**Recommendation:**

This item is included on the Sector’s agenda to make members aware of this proposal to add new paragraphs to NIST Handbook 44, Vehicle-Tank Meters, Notes Section and to ask for input from the Sector on the recommended changes. This item appeared on the 2014 NCWM S&T Committee agenda as a Developing item. NIST OWM is recommending the “Examples” in the proposal are more appropriately included in the EPO’s and training materials rather than in NIST Handbook 44.

**Background/Discussion:**

Ms. Julie Quinn (Minnesota Weights and Measures Division) reported that a group of interested parties formed what they refer to as the “Multiple Point Calibration Group” and have been collaborating to discuss requirements for vehicle-tank meter systems with the capability to be calibrated at different flow rates and for different products.

During the 2014 NCWM Annual Meeting, this group met and developed suggested language to address this issue. Ms. Quinn asked that the S&T Committee include the suggested language in this item for further review and comments by the regional associations and others in the fall. The following language, along with a change to the title of the item (see 2014 NCWM Publication 16), was suggested:

**N.4.6. Initial Verification. – A vehicle tank meter shall be tested at all flow rates and with all products for which a calibration factor has been electronically programmed prior to placing it into commercial service for the first time or after being repaired or replaced.**

**A vehicle tank meter not equipped with means to electronically program its flow rates and calibration factors shall be tested at a low and high flow rate with all products delivered prior to placing it into commercial service for the first time or after being repaired or replaced.**

**Example: A vehicle tank meter is electronically programmed to deliver regular and premium gasoline at a startup/shutdown flow rate of 20 gpm, a normal operating flow rate of 100 gpm, and an intermediate rate of 65 gpm. The meter is to be tested with regular gasoline at 20 gpm, 65 gpm and 100 gpm; and with premium gasoline at 20 gpm, 65 gpm and 100 gpm.**

**The official with statutory authority has the discretion to determine the flow rates and products at which a vehicle tank meter will be tested on subsequent verifications.**

**UR.1.5. Initial Verification Proving Reports. - Initial verification proving reports for vehicle tank meters equipped with means to electronically program flow rates shall be attached to and sent with placed-in-service reports when the regulatory agency with statutory authority requires placed-in-service reports.**

Members of this group have agreed to do a presentation at each of the 2014 fall regional meetings to explain this item and other related proposals.

**Discussion:**

The 2014 NTEP Measuring Sector heard discussion on this item at the same time as the other related multiple point calibration items. The discussions, comments, and concerns were the same as agenda Item 10 above (see the summary under agenda Item 10 for the details).



**Decision:**

The 2014 NTEP Measuring Sector did not reach consensus on this item nor its related Items 10, 12, 13, and 14. No recommendation was presented by the Sector.

**12. 3.30. Liquid-Measuring Devices, N.4.1.3. Normal Tests on Wholesale Multi-Point Calibration Devices.**

**Source:**

Multi-Point Calibration Group (MPCG) (2014).

**Recommendation:**

No action is asked of the Measuring Sector at this time. This update is being provided to make members of the Measuring Sector aware of this proposal to add new paragraphs to NIST Handbook 44, Liquid-Measuring Devices. A group of experts led by Ms. Julie Quinn (Minnesota), referred to as the “Multiple Point Calibration Group (MPCG),” has developed a new proposal to establish the tests to be conducted on wholesale meters with multiple point calibration capability.

**Background/Discussion:**

The MPCG states that new technology makes it possible to use linearization factors to optimize accuracy at every speed for which a wholesale meter is programmed to deliver. A special tolerance has traditionally been applied to slow flow tests for various flow test on wholesale meters with mechanical single-point calibrators because accuracy could only be optimized at one flow rate. A wholesale meter programmed with multi-point calibration does not require a special tolerance at any flow rate since every flow rate can be adjusted as close to zero as the repeatability of the meter allows.

The MPCG proposes to add a new paragraph to Section 3.30. LMD Code is as follows:

**N.4.1.3. Normal Tests on Wholesale Multi-Point Calibration Devices. – The normal test of a wholesale liquid-measuring device with electronically programmed linearization factors for various flow rates shall be made at the maximum discharge rate developed by the installation. Any additional test conducted at flow rates down to and including the indicated minimum discharge flow rate shall be considered normal tests.**

**(Added 20XX)**

**Discussion:**

The 2014 NTEP Measuring Sector heard discussion on this item at the same time as the other related multiple point calibration items. See the summary under agenda Item 10 above for the details.

**Decision:**

The 2014 NTEP Measuring Sector did not reach consensus on this item nor its related Items 10, 11, 13, and 14. No recommendation was presented by the Sector.

**13. 3.31. Vehicle-Tank Meters, N.4.1.4. Normal Tests on Multi-Point Calibration Devices.**

**Source:**

Multi-Point Calibration Group (MPCG) (2014).

**Recommendation:**

No action is asked of the Measuring Sector at this time. This update is being provided to make members of the Measuring Sector aware of this proposal to add new paragraphs to NIST Handbook 44, Vehicle-Tank Meters. A group of experts led by Ms. Julie Quinn (Minnesota), referred to as the “Multiple Point Calibration Group (MPCG),” has developed a new proposal to establish the tests to be conducted on vehicle-tank meters with multiple point calibration capability.

**Background/Discussion:**

The MPCG states that new technology makes it possible to use linearization factors to optimize accuracy at every speed for which a vehicle-tank meter is programmed to deliver. A special tolerance has traditionally been applied to slow flow tests on vehicle-tank meters with mechanical single-point calibrators because accuracy could only be optimized at one flow rate. A vehicle-tank meter programmed with multi-point calibration does not require a special tolerance at any flow rate since every flow rate can be adjusted as close to zero as the repeatability of the meter allows.

The MPCG proposes to add a new paragraph to Section 3.31. VTM Code is as follows:

**N.4.1.4. Normal Test on Multi-Point Calibration Devices. – The normal test of a vehicle-tank meter with electronically programmed linearization factors for various flow rates shall be made at the maximum discharge rate developed by the installation. Any additional tests conducted at flow rates down to and including the rated minimum discharge flow rate shall be considered normal tests.**

**(Added 20XX)**

**Discussion:**

The 2014 NTEP Measuring Sector heard discussion on this item at the same time as the other related multiple point calibration items. See the summary under agenda Item 10 above for the details.

**Decision:**

The 2014 NTEP Measuring Sector did not reach consensus on this item nor its related Items 10, 11, 12, and 14. No recommendation was presented by the Sector.

**14. Appendix D – Definitions: Calibration Parameter and Multi-Point Calibrated Device.**

**Source:**

Multi-Point Calibration Group (MPCG) (2014).

**Recommendation:**

No action is asked of the Measuring Sector at this time. This update is being provided to make members of the Measuring Sector aware of this proposal to amend NIST Handbook 44, Definitions. A group of experts led by Ms. Julie Quinn (Minnesota), referred to as the “Multiple Point Calibration Group (MPCG),” has developed a new proposal to amend the existing definition of *calibration parameter* and to add a new definition for *Multi-Point Calibrated Device*.

**Background/Discussion:**

The MPCG noted that in 2006, NIST Handbook 44, Sections 3.31., 3.32., 3.34., and 3.35., were amended, and referenced calibration parameters. Consequently, the definition needs to be updated to include references to these sections.

The MPCG also noted that a definition for “Multi-point Calibrated Device” needs to be added to recognize new technology that makes it possible to use linearization factors to optimize accuracy at multiple measurement points on devices such as meters and scales. This new technology requires a term so that devices capable of being optimized at multiple measurement points can be distinguished from devices with single-point calibration.

The MPCG’s proposes the following amendments and addition to Appendix D – Definitions:

**calibration parameter.** – Any adjustable parameter that can affect measurement or performance accuracy and, due to its nature, needs to be updated on an ongoing basis to maintain device accuracy, (e.g., span adjustments, linearization factors, and course zero adjustments). [2.20, 2.21, 2.24, 3.30, **3.31, 3.32, 3.34, 3.35**, 3.37, 5.56(a)]

(Added 1993) **(Amended 20XX)**

**Multi-point Calibrated Device. – A device equipped with means to electronically program linearization factors at multiple measurement points.**

**(Added 20XX)**

**Discussion:**

The 2014 NTEP Measuring Sector heard discussion on this item at the same time as the other related multiple point calibration items. See the summary under agenda Item 10 above for the details.

**Decision:**

The 2014 NTEP Measuring Sector did not reach consensus on this item nor its related Items 10, 11, 12, and 13. No recommendation was presented by the Sector.

**15. NCWM S&T Item 332-1 D – S.1.4.3. Provisions for Power Loss; S.1.5.1.1. Unit Price; S.1.5.1.2. Product Identity; S.1.6. For Retail Motor Fuel Dispensers Only; S.1.7. For Wholesale Devices Only; UR.2.7. Unit Price and Product Identity; and UR.2.8. Computing Device.**

**Source:**

California Department of Food and Agriculture (CDFA), Division of Measurement Standards (DMS).

**Recommendation:**

The Measuring Sector was asked for their input on this item. This update is being provided to make members of the Measuring Sector aware of this proposal that appeared on the 2014 NCWM S&T Committee agenda as a Developing item to amend NIST Handbook 44, LPG and Anhydrous Ammonia Liquid-Measuring Device, Specification and User Requirement codes.

See the 2014 Measuring Sector Agenda, Appendix D for the entire proposal along with NIST OWM's comments as they appeared in the 2014 NCWM Publication 16.

**Background:**

The purpose is to add similar Specifications and User Requirements of other retail motor-fuel devices to NIST Handbook 44, Section 3.32. Liquefied Petroleum Gas (LPG) and Anhydrous Liquid-Measuring Devices Code similar to those in Section 3.30. Liquid-Measuring Devices; Section 3.37. Mass Flow Meters; and Section 3.39. Hydrogen-Gas Measuring Devices, Tentative Code.

The NCWM S&T Committee supports the objective of making changes to align the LPG and the LMD Code with respect to requirements for retail motor-fuel dispensing applications.

During the 2014 NCWM Annual Meeting, the S&T Committee heard numerous comments that additional work on this item is needed. The Committee agreed to recommend this item remain Developmental.

**Discussion:**

The 2014 NTEP Measuring Sector heard many comments on this item.

It was discussed that there is an ever-increasing number of liquefied petroleum gas (LPG) dispensers being installed that are intended for and used in retail motor fueling applications. Mr. Roach (CDFA DMS) stated that this proposed language is needed because devices used to dispense LPG are specifically exempted from NIST Handbook 44, Section 3.30. Liquid-Measuring Devices, in A.2. Exceptions (b), and that Section 3.32. LPG and NH<sub>3</sub> does not have adequate requirements addressing retail motor fueling applications.

At the 2014 Western Weights and Measures Association (WWMA) meeting, the submitter of this proposal, Mr. Steve Cook (CDFA DMS), provided a revised version for consideration. See the WWMA S&T Committee's Final Report on the NCWM web site for that revision. Mr. Cook stated that it is acceptable to him for this item remain Informational (I) to allow for further input.

**Decision:**

The 2014 NTEP Measuring Sector decided to keep this item on its agenda for next year (2015). It supports the concept that LPG retail motor fuel dispenser (RMFD) requirements should be the same as those in NIST Handbook 44, Section 3.30. However, the Sector wishes to take time and carefully go through the proposal to make sure that there are no conflicts with other codes and to assure that it applies to RMFD only.

**16. Event Logger; Electronic Transfer of Information.**

**Source:**

Gordon Johnson, Gilbarco (2014)

**Recommendation:**

This item is included on the Sector's agenda to make members of the Measuring Sector aware of this proposal to amend NIST Handbook 44, Section 3.30. Liquid-Measuring Devices, *Table S.2.2. Categories of Device and Methods of Sealing*, and to allow the Sector opportunity to discuss and comment on the item.

**Background:**

This item has been submitted by Mr. Gordon Johnson (Gilbarco) to the 2014 Southern and Western Weights and Measures Association S&T Committees for their consideration. The intent of the proposal is to allow electronic means (e.g., a thumb drive, flash drive, laptop computer, e-mail, or cell phone) as an alternative to providing event logger information for Category 3 devices in hard copy form.

**Discussion:**

The 2014 NTEP Measuring Sector thoroughly discussed and debated this item.

This item is titled, *Table S.2.2. Categories of Device and Methods of Sealing*, on the WWMA and SWMA S&T Committee's agendas.

Mr. Cooney (NIST, OWM) reported that Mr. Johnson (Gilbarco, Inc.) made a presentation on this item to the 2014 WWMA Annual Technical Conference and described the limitation with onsite printing devices. Part of his presentation was rolling out a very long roll of paper that the audit trail information is currently printed on from one of his company's dispensers. He described the difficulty of physically sorting through the list of data on the printout. However, he stated that if this information were provided electronically, then it could be sorted much more efficiently. Furthermore, the printers often sit unused inside of his dispensers resulting in necessary repair or replacement and maintaining rolls of paper in the device.

In addition, Mr. Cooney reported that the WWMA S&T Committee believes that this item has merit and would more easily facilitate examination of an audit trail; however, they have concerns regarding the security of the information that is downloaded and the potential for data manipulation. They also expressed concerns that the term, "electronic means," in this proposal may include other means that are not listed in the table and that providing examples of the "electronic means" may not be appropriate. Furthermore, the Committee has concerns on what equipment weights and measures officials will need in the field and that they may not have access to in order to retrieve the event data on-site and in a timely manner. The WWMA S&T Committee gave this item Developing (D) status on their agenda to allow the submitter time to refine the proposal. For further details, see the WWMA S&T Committee's Final Report on the NCWM website.

Ms. Butcher (NIST, OWM) pointed out that some regulatory inspectors do not have electronic access capabilities. She continued that if adopted, this proposal would create a major hurdle to these jurisdictions to be able to have immediate access to audit trail information in printed form, be able to study the information, and to in turn, provide the printed information with their reports. Mr. Katalinic (North Carolina Weights and Measures) stated that the provision for a printed copy of the information should be available whether or not the device provides the information electronically. Mr. Roach (CDFA DMS) agreed and stated that a printed copy must always be required.

Upon first reading of this proposal, members of the Measuring Sector believed that this proposal should be placed into all Category 3 requirements in NIST Handbook 44.

Some members of the Sector acknowledged concerns that some businesses and governmental agencies do not permit devices such as “thumb drives” to be inserted into their equipment.

Mr. Moses (Wayne) suggested that perhaps requiring every device have an onsite printer as opposed to an internal one. Mr. Tucker (RL Tucker Consulting, LLC) stated that the specific device would need to be identified electronically so that when the information was downloaded onto a thumb drive and then it was taken to a printer, that device identity would be printed along with the other information.

Ms. Butcher stated that if a printed copy was going to be required anyway, then the amendments are not necessary. She stated that currently the information may be sent to a printer electronically. She suggested a possible compromise would be to allow the equipment to supply only electronic information and require that there be an onsite printer from which the event logger information may be printed. This would be accomplished by adding a User Requirement (UR) to NIST Handbook 44 LMD code that a capable printer be provided at the location by the operator. Mrs. Butcher acknowledged the direction of electronics; however, she once again emphasized that not all inspectors have the ability to access information electronically.

The manufacturers represented at the Sector supported the item as written; however, the NTEP Laboratories present at the meeting did not. The Laboratories believe a printed record must be required.

Various amendments to those proposed in this item were discussed at length. The Measuring Sector agreed to amend the original proposal in Table S.2.2. Categories of Device and Methods of Sealing as follows:

<b>Table S.2.2. Categories of Device and Methods of Sealing</b>	
<b>Categories of Device</b>	<b>Methods of Sealing</b>
<b>Category 1:</b> (No changes)	(No changes)
<b>Category 2:</b> (No changes)	(No changes)
<p><i>Category 3: Remote configuration capability access may be unlimited or controlled through a software switch (e.g., password).</i>            [Nonretroactive as of January 1, 1995]</p> <p><i>The device shall clearly indicate that it is in the remote configuration mode and record such message if capable of printing in this mode or shall not operate while in this mode.</i>            [Nonretroactive as of January 1, 2001]</p>	<p><i>An event logger is required in the device; it must include an event counter (000 to 999), the parameter ID, the date and time of the change, and the new value of the parameter. <b><u>The use of an electronic means such as a thumb drive, flash drive, laptop computer, Email, cell phone may be used to receive the event logger information from the device or another on-site device.</u></b> A printed copy of the information must be available through the device or through another on-site device <b><u>if the device is not equipped to offer an electronic means of supplying the information.</u></b> The event logger shall have a capacity to retain records equal to 10 times the number of sealable parameters in the device, but not more than 1000 records are required. (Note: Does not require 1000 changes to be stored for each parameter.)</i></p>

[Nonretroactive as of January 1, 1995]

(Table Added 1993) (Amended 1995, 1998, 1999, ~~and~~ 2006, and 20XX)

**Decision:**

The 2014 Sector decided that this proposal needs further development and to carry it over to its 2015 agenda.

## 17. S&T Committee Carryover Item 337-2 Equivalent Units for Natural Gas.

### Recommendation:

The NCWM S&T Committee is deliberating on proposed changes to NIST Handbook 44 to recognize “alternative units” for natural gas. The S&T Committee would value input from the Sector on this issue. The Sector is asked to review and provide comment to the S&T Committee on this issue.

The S&T Committee proposed the following changes to NIST Handbook 44, Appendix D. Definitions and Section 3.37. Mass Flow Meters Code at the 2014 NCWM Annual Meeting. The proposal did not receive sufficient support for adoption and was returned to the Committee for further consideration.

Amend NIST Handbook 44, Appendix D to include new definitions as follows:

**diesel gallon equivalent (DGE). – means 6.384 pounds of compressed natural gas or 6.059 pounds of liquefied natural gas. [3.37]**

**diesel liter equivalent (DLE). – means 0.765 kilograms of compressed natural gas or 0.726 kilograms of liquefied natural gas. [3.37]**

Amend NIST Handbook 44, Appendix D. Definitions as follows:

**gasoline gallon equivalent (GGE). – Gasoline gallon equivalent (GGE) means 5.660 pounds of compressed natural gas. [3.37]**

**gasoline liter equivalent (GLE). – Gasoline liter equivalent (GLE) means 0.678 kilograms of compressed natural gas. [3.37]**

**(Added 1994)**

Amend NIST Handbook 44, Mass Flow Meters Code paragraphs S.1.2., S.1.3.1.1., and UR.3.8.; delete paragraph S.5.2.; and add new paragraph S.1.3.1.2. as follows:

**S.1.2. Compressed Natural Gas and Liquefied Natural Gas Dispensers.** – Except for non-retail fleet sales and other price contract sales, a compressed natural gas **and liquefied natural gas** dispensers used to refuel vehicles shall be of the computing type and shall indicate the quantity, the unit price, and the total price of each delivery. The dispensers shall display the mass measured for each transaction either continuously on an external or internal display accessible during the inspection and test of the dispensers, or display the quantity in mass units by using controls on the device.

(Added 1994)

### S.1.3. Units

**S.1.3.1.1. Compressed Natural Gas Used as an Engine Fuel.** – When compressed natural gas is dispensed as an engine fuel, the delivered quantity shall be **measured in mass and** indicated in “gasoline liter equivalent (GLE) units,” “gasoline gallon equivalent (GGE) units,” **diesel liter equivalent (DLE) units, or diesel gallon equivalent (DGE) units.** (Also see definitions.)

(Added 1994)

**S.1.3.1.2. Liquefied Natural Gas Used as an Engine Fuel.** – **When liquefied natural gas is dispensed as an engine fuel, the delivered quantity shall be measured in mass and indicated in “diesel liter equivalent (DLE) units” or “diesel gallon equivalent (DGE) units.”** (Also see definitions.)

**S.5.2. ~~Marking of Gasoline Volume Equivalent Conversion Factor.~~** – **~~A device dispensing compressed natural gas shall have either the statement “1 Gasoline Liter Equivalent (GLE) is Equal to 0.678 kg of~~**

~~Natural Gas” or “1 Gasoline Gallon Equivalent (GGE) is Equal to 5.660 lb of Natural Gas” permanently and conspicuously marked on the face of the dispenser according to the method of sale used.~~  
(Added 1994)

**UR.3.8. Return of Product to Storage, Retail Compressed Natural Gas and Liquefied Natural Gas Dispensers.** – Provisions at the site shall be made for returning product to storage or disposing of the product in a safe and timely manner during or following testing operations. Such provisions may include return lines, or cylinders adequate in size and number to permit this procedure.  
(Added 1998)

**Background:**

The gasoline gallon equivalent (GGE) unit was defined by NCWM in 1994 to allow users of natural gas vehicles to compare costs and fuel economy of light-duty compressed natural gas vehicles with equivalent gasoline powered vehicles. More background on the efforts of NIST/NCWM is available in the Reports of the 78<sup>th</sup> and 79<sup>th</sup> NCWM in NIST Special Publication 854 and 870 (see pages 322 and 327, respectively). Natural gas is sold as a vehicle fuel as either Compressed Natural Gas (CNG) or Liquefied Natural Gas (LNG). For medium and heavy duty natural gas vehicles in widespread use today, there is a need to officially define a unit allowing a comparison of cost and fuel economy with diesel powered vehicles. The submitter stated that the official definition of a DLE and a DGE will likely provide justification for California, Wisconsin, and many other states to permit retail sales of CNG for heavy-duty vehicles in these convenient units. The submitter has provided a mathematical justification for the specific quantity (mass) of compressed natural gas in a DLE and DGE, which found in the S&T Committee’s 2014 Interim Report.

At the 2014 NCWM Annual Meeting, the Committee heard numerous comments in both opposition to and support of the proposal shown in the Item Under Consideration in NCWM Publication 16. These comments are summarized below:

**Support:**

- Numerous letters of support were received from U.S. Senators, Governors, with wide bipartisan support.
- Allows consumers who may be familiar with volumetric units to make value comparisons.
- Allows for cost comparison between multiple fuel types.
- The proposal is supported by those who build and supply the equipment, vehicle manufacturers, and producers and distributors of natural gas.
- If action isn’t taken, the decision will be taken out of the Weights and Measures jurisdictions’ hands at the state and local levels.
- The “GGE” has been in use and accepted for many years.
- If the primary method of sale is mass, it dictates price, sale, and advertising be in mass. Mass units are not consumer friendly. Consumers don’t understand price per kilogram or pound for fuel sales.
- Industry stated that equivalent units are what consumers want.
- At least one company reported that all of their business is built around the “DGE” and they would need to retrofit their dispensers if required to measure in mass.
- Natural gas retail dispensers measure in mass and are inspected and tested using mass units.

**Opposition:**

- Use of the word approximate.
- This is a marketing rather than technical issue.
- Will there be potential for proliferation of other equivalent units for other alternative fuels?
- There are questions concerning the validity of the conversion values and whether adequate research has been done to develop the values.
- Including more than one equivalent value could lead to consumer confusion.
- The proposal is not aligned with how natural gas is being sold in the rest of the world.
- A jurisdiction stated that consumers hadn't been asked how they want natural gas sold.
- Is there a need for ongoing value comparisons if a vehicle is dedicated to run on natural gas fuel?
- Measurement science needs to be based on traceable standards. Equivalent units are not traceable.
- Consumers may need to make comparisons with multiple different fuel types such as diesel, biodiesel, gasoline, fuel ethanol, electric, hydrogen, LNG, and others. What is the most appropriate means to provide sufficient information to customers attempting to make value comparisons?
- Equivalent units would be better provided as supplemental information rather than the basis for commercial transactions.

**Other technical points that were raised include the following:**

- NTEP certificates have already been issued for five LNG dispensers that measure and indicate in mass units only. How will the proposed changes affect this equipment?

The Committee received an alternative proposal from NIST, OWM that would require dispensers to measure, indicate, and calculate the total selling price based on mass units (pounds or kilograms), but permit the posting of supplemental information regarding approximate equivalents to other fuels for use by consumers when making value comparisons or for use by tax agencies. Based upon multiple requests from the regional weights and measures association meetings during the 2014 NCWM Annual Meeting and the Committee's open hearings, the Committee agreed to include this proposal in its Final Report. These proposed changes to Section 3.37. Mass Flow Meters Code are shown in the following table.

**Summary of Compromise Proposal:**

*This alternative proposal was offered as a compromise that would phase in requirements for natural gas vehicle dispensers to measure, indicate, and calculate the total selling price based on mass units (pounds or kilograms), but permit the posting of supplemental information regarding approximate equivalents to other fuels for use by consumers in making value comparisons or by tax agencies while preserving the integrity of the measurement process. With this approach, customers could still be provided with supplemental information through mechanisms such as pump toppers or other displays that provide information about estimated equivalent units of measurement for deliveries indicated in mass as well as information on web sites such as those that already provide information about fuel economy. This approach might also reduce complaints from some suppliers about the accuracy of equivalent values relative to their product.*



**S.1. Indicating and Recording Elements.**

...

**S.1.2. Compressed Natural Gas Dispensers.** – Except for fleet sales and other price contract sales, a ~~compressed~~ natural gas dispenser used to refuel vehicles shall be of the computing type and shall indicate the quantity, the unit price, and the total price of each delivery. ~~The dispenser shall display the mass measured for each transaction either continuously on an external or internal display accessible during the inspection and test of the dispenser, or display the quantity in mass units by using controls on the device.~~  
(Added 1994) (Amended 20XX)

**S.1.3. Units.**

**S.1.3.1. Units of Measurement.** – Deliveries shall be indicated and recorded in grams, kilograms, metric tons, pounds, tons, and/or liters, gallons, quarts, pints and decimal subdivisions thereof. The indication of a delivery shall be on the basis of apparent mass versus a density of 8.0 g/cm<sup>3</sup>. The volume indication shall be based on the mass measurement and an automatic means to determine and correct for changes in product density.  
(Amended 1993 and 1997)

**S.1.3.1.1. Compressed Natural Gas Used as an Engine Fuel.** – When ~~compressed~~ natural gas is dispensed as an engine fuel, the delivered quantity shall be indicated as follows:

- (a) Effective and Nonretroactive as of January 1, 2016, the delivered quantity shall be indicated in mass units in terms of kilograms or pounds and decimal subdivisions thereof.

This paragraph will become retroactive on January 1, 2017.

(Added 20XX)

- (b) For dispensers manufactured prior to January 1, 2016, the dispenser shall display the mass measured for each transaction, either continuously on an external or internal display accessible during the inspection and test of the dispenser, or display the quantity in mass units by using controls on the device. The delivered quantity shall be indicated in mass or in “gasoline liter equivalent (GLE) units” or “gasoline gallon equivalent (GGE) units.” (Also see ~~d~~Definitions.)

(Added 1994) (Amended 20XX)

Paragraph S.1.3.1.1.(b) will be removed in the 2017 edition of NIST Handbook 44 when paragraph S.1.3.1.1.(a) becomes retroactive.

**S.1.3.1.2. Natural Gas Used as an Engine Fuel, Supplemental Information.** – Dispensers of natural gas dispensed as an engine fuel may include supplemental information to assist consumers in making value comparisons with gasoline and diesel fuel and for use by taxation departments and other agencies that may need an approximation thereof. Supplemental information shall not appear adjacent or in close proximity to the primary display and shall be positioned far enough from that display so as to ensure that the quantity, unit price, and total price for the transaction are clear and easily understood.

Supplemental units shall be clearly designated with the phrase “The following information is provided for comparison with other vehicle fuels and is not to be used as a basis for commercial transactions.”

**Supplemental units shall be displayed using one or more of the following statements.**

**For compressed natural gas:**

**1 kg of Compressed Natural Gas is Equal to 1.4749 Gasoline Liter Equivalent (GLE)**  
**1 kg of Compressed Natural Gas is Equal to 0.3896 Gasoline Gallon Equivalent (GGE)**  
**1 kg of Compressed Natural Gas is Equal to 1.3072 Diesel Liter Equivalent (DLE)**  
**1 kg of Compressed Natural Gas is Equal to 0.3455 Diesel Gallon Equivalent (DGE)**

**1 lb of Compressed Natural Gas is Equal to 0.669 Gasoline Liter Equivalent (GLE)**  
**1 lb of Compressed Natural Gas is Equal to 0.177 Gasoline Gallon Equivalent (GGE)**  
**1 lb of Compressed Natural Gas is Equal to 0.593 Diesel Liter Equivalent (DLE)**  
**1 lb of Compressed Natural Gas is Equal to 0.157 Diesel Gallon Equivalent (DGE)**

**For liquefied natural gas:**

**1 kg of Liquefied Natural Gas is Equal to 1.3768 Diesel Liter Equivalent (DLE)**  
**1 kg of Liquefied Natural Gas is Equal to 0.3638 Diesel Gallon Equivalent (DGE)**

**1 lb of Liquefied Natural Gas is Equal to 0.625 Diesel Liter Equivalent (DLE)**  
**1 lb of Liquefied Natural Gas is Equal to 0.165 Diesel Gallon Equivalent (DGE)**

...

**S.1.3.3. Maximum Value of Quantity-Value Divisions.**

- (a) **The maximum value of the quantity-value division for liquids shall not be greater than 0.2 % of the minimum measured quantity.**
- (b) *Effective and nonretroactive as of January 1, 2016, the maximum value of the mass division for dispensers of natural gas used to refuel vehicles shall not exceed 0.001 kg or 0.001 lb.*

**Note: Paragraph S.1.3.3.(b) will become retroactive effective January 1, 2017.**

- (c) For dispensers of ~~compressed~~ natural gas used to refuel vehicles **and manufactured prior to January 1, 2016**, the value of the division for the gasoline liter equivalent shall not exceed 0.01 GLE; the division for gasoline gallon equivalent (GGE) shall not exceed 0.001 GGE. The maximum value of the mass division shall not exceed 0.001 kg or 0.001 lb.

**Note: Paragraph S.1.3.3.(c) will be removed in the 2017 edition of NIST Handbook 44 when Paragraph S.1.3.3.(b) becomes retroactive.**

(Amended 1994 ~~and 20XX~~)

...

**S.5. Markings. ...**

**S.5.2. Marking of Gasoline Volume Equivalent Conversion Factor. – ~~A device~~ Dispensers manufactured prior to January 1, 2016, dispensing compressed natural gas shall have either the statement “1 Gasoline Liter Equivalent (GLE) is Equal to 0.678 kg of Natural Gas” or “1 Gasoline Gallon Equivalent (GGE) is Equal to 5.660 lb of Natural Gas” permanently and conspicuously marked on the face of the dispenser according to the method of sale used.**

**As of January 1, 2017, devices must indicate as specified in S.1.3.1.1.(a) and any information providing equivalent units may only be included as supplemental information as specified in S.1.3.1.2.**

**Paragraph S.5.2. will be removed from the 2017 edition of NIST Handbook 44 when paragraph S.1.3.1.1.(a) becomes retroactive.**

(Added 1994) (**Amended 20XX**)

**UR.3. Use of Device.**

...

**UR.3.8. Return of Product to Storage, Retail Compressed Natural Gas and Liquefied Natural Gas Dispensers.** – Provisions at the site shall be made for returning product to storage or disposing of the product in a safe and timely manner during or following testing operations. Such provisions may include return lines, or cylinders adequate in size and number to permit this procedure.

(Added 1998) (**Amended 20XX**)

Because many of these issues are dependent upon defining the proper method of sale, the Committee met jointly with the L&R Committee to discuss the comments received on the S&T and L&R proposals on the issues relating to natural gas.

The S&T Committee identified the method of sale by mass versus equivalent volumetric units as the most significant concern based on comments heard on this proposal. In addition to support for this proposal, there were also concerns regarding the use of the word “approximately” for labeling purposes; “multiple equivalent units” labeled on the same dispenser; “tax issues;” and other less commonly expressed issues. It was decided to eliminate the labeling altogether and not delay the effective date, thereby, addressing all three concerns. Consequently, based upon the comments received and its deliberations, the Committee agreed to modify the Item Under Consideration shown in NCWM Publication 16. The revised version of the Committee’s proposal appears in the “Recommendation” above.

**Discussion:**

The 2014 NTEP Measuring Sector discussed this item.

Mr. Moses (Wayne) and Mr. Drube (Chart Industries) updated the Measuring Sector on discussions at the 2014 Western Weights and Measures Association (WWMA) meeting.

Mr. Cooney (NIST, OWM) stated that the same positions and arguments that were expressed at the WWMA meeting were much the same as those at the 2014 NCWM Annual Meeting. He stated that the Natural Gas Steering Committee is discussing and working through proposals to bring to the 2015 NCWM Interim Meeting in January. The Steering Committee hopes that progress will be made to move this matter forward at the 2015 NCWM Annual Meeting.

**Decision:**

The 2014 NTEP Measuring Sector agreed that significant discussion, vigorous debate, hard work, and potential compromise solutions have gone into this item. The Sector had no additional input and supports the work of the Natural Gas Steering Committee. The Sector is looking forward to the results of the Steering Committee’s deliberations and what they will present to the upcoming 2015 NCWM Interim Meeting.

**End of the 2014 NTEP Measuring Sector’s Final Report Summary.**

## Appendix D/Sub-Appendix A

### National Type Evaluation Program

#### Draft Checklist for Testing Electronic Digital Indicators – with Limited Editorial Notes

This checklist is used for Technical Policy U. Evaluating electronic digital indicators submitted separate from a measuring element, this section is intended for lab testing only.

Is permanence necessary? If new evaluation (yes) if updating existing CC (no).

##### Code Reference: G-S.1. Identification

All equipment shall be clearly and permanently marked on an exterior visible surface after installation. It must contain the following information (prefix lettering may be initial capitals, all capitals, or all lower case):

- 1.1. Name, initials, or trademark of the manufacturer. **Yes**  **No**  **N/A**
- 1.2. A model designation that positively identifies the pattern or design. The Model designation shall be prefaced by the word "Model", "Type", or "Pattern". These terms may be followed by the term "Number" or an abbreviation of that word. The abbreviation for the word "Number" shall, at a minimum, begin with the letter "N" (e.g., No or No.) The abbreviation for the word "Model" shall be "Mod" or "Mod.". **Yes**  **No**  **N/A**
- 1.3. Except for not built-for-purpose, software-based devices, a nonrepetitive serial number. The serial number shall be prefaced by words, an abbreviation, or a symbol, that clearly identifies the number as the required serial number. Abbreviations for the word "Serial" shall, as a minimum, begin with the letter "S," and abbreviations for the word "Number" shall, as a minimum, begin with the letter "N" (e.g., S/N, SN, Ser. No, and S No.). **Yes**  **No**  **N/A**
- 1.4. For not built-for-purpose, software-based devices the current software version or revision designation. The version or revision identifier shall be prefaced by the word "Version" or "Revision" as appropriate and either word may be followed by the word "Number." The abbreviations for the word "Version" shall, as a minimum, begin with the letter "V". The abbreviation for the word "Number" shall, as a minimum, begin with the letter "N" (e.g., No or No.). **Yes**  **No**  **N/A**

**Code Reference G-S.1. (e).**

- 1.5. The NTEP Certificate of Conformance (CC) Number or a corresponding CC addendum number for devices that have a CC. The number shall be prefaced by the terms "NTEP CC", "CC", or "Approval". These terms may be followed by the word "Number" or an abbreviation for the Word "Number". The abbreviation shall as a minimum begin with the letter "N" (e.g., No or No.). Yes  No  N/A

The device must have an area, either on the identification plate or on the device itself, suitable for the application of the Certificate of Conformance Number. If the area for the CC Number is not part of an identification plate, then note its intended location below and how it will be applied. Ex. May be part of W&M display screen, using the requirements of section 1.6.2.

Location of CC Number if not located with the identification:

---

---

**Code Reference: G-S.1.1. Location of Marking Information for Not Built-for-Purpose, Software-Based Devices Not Built-for-Purpose Devices, Software-Based**

- 1.6. For not built-for-purpose, software-based devices the following shall apply:
- 1.6.1. The required information in G-S.1 Identification. (a), (b), (d), and (e) shall be permanently marked or continuously displayed on the device; or
- 1.6.2. The Certificate of Conformance (CC) Number shall be:
- permanently marked on the device; or
  - continuously displayed; or
  - accessible through an easily recognized menu and, if necessary, a submenu. Examples of menu and submenu identification include, but are not limited to "Help," "System Identification," "G-S.1. Identification," or "Weights and Measures Identification."

Note: For (1.6.2.), clear instructions for accessing the information required in G-S.1. (a), (b), and (d) shall be listed on the CC, including information necessary to identify that the software in the device is the same type that was evaluated.

**Code Reference: G-S.2. Facilitation of Fraud**

This applies to all metering system indicators installed at a fixed location or vehicle tank meter applications and controlled remotely or within the device itself.

This requirement addresses the process of changing the unit price or unit prices set in a metering system.

Other item fall under facilitation of fraud, needs more input.

Example if Cat 3 device verify passwords and audit trail is correct...

- 1.9. The system shall prevent a change of unit price during a delivery. Yes  No  N/A

**Code Reference: G-S.3. Permanence How would this be conducted or not?**

~~Equipment shall be of such materials, design, and construction that, under normal service conditions:~~

~~1.10. Accuracy will be maintained. Yes  No  N/A~~

~~1.11. Operating parts will continue to function as intended. Yes  No  N/A~~

~~1.12. Adjustments will remain reasonably permanent. Yes  No  N/A~~

AK - This is not a lab issue, this is a field requirement due to the fact that the equipment is being lab evaluated, the evaluator will not see the end use installation.

**Code Reference: G-S.4. Interchange or Reversal of Parts**

If a metering system has parts that may be interchanged or reversed in normal field assembly, the system shall either be constructed so that reversal will not affect the accuracy of the system or the parts must be marked to indicate their proper position. For most metering devices, this applies only to the reversal of connectors of cables to peripheral devices.

If a metering system has any parts that may be interchanged or reversed in normal field assembly, the parts must either be:

1.13. Constructed so that reversal will not affect performance, Yes  No  N/A

1.14. Marked or keyed to indicate their proper positions. May have multiple cable connections but not interchangeable due to different plug styles, or Yes  No  N/A

1.15. Cables are connected but are not removable without breaking a seal and opening housing. (Note: may need HB 44 requirement to cover this.) Yes  No  N/A

**2. Indications, and Recorded Representations Look at different codes**

**Code Reference: G-S.5.1. Indicating and Recording Elements**

Several general requirements facilitate the reading and interpretation of displayed values. Each display for quantity or total price must be appropriate in design and have sufficient capacity for particular applications to be suitable for the application. Metering devices must be capable of indicating the maximum quantity and money values that can normally be expected in a particular application.

**2.1. Minimum quantity value indications.**

2.1.1. Display is capable of 1\_0 Yes  No  N/A

2.1.2. Display is capable of 0\_1 Yes  No  N/A

2.1.3. Display is capable of 0.01 Yes  No  N/A

2.1.4. Display is capable of 0.001 Yes  No  N/A

2.1.5. Display is capable of other (fill in blank): needs comment section

**2.2. Money value display.**

2.2.1. a. Money value is properly displayed and verify rounding Yes  No  N/A

b. Verify the presents of currency symbol **i.e. dollar sign "\$" or "Dollars"** Yes  No  N/A

3.2. **The indications must be clear, definite, and accurate.**

- 2.2.1. Values must be clear, definite, and accurate **Yes**  **No**  **N/A**
- 2.2.2. Unit of measure is programmable Gallon, Liter, Pound **Yes**  **No**  **N/A**
- 2.2.2. Unit of measure is applied by permanent marking on indicator housing **Yes**  **No**  **N/A**
- 2.3. The indications must be easily read under normal operating conditions. **Yes**  **No**  **N/A**
- 2.4. Symbols for decimal points shall clearly identify the decimal position. (Generally acceptable symbols are dots, small commas, or x.) **Yes**  **No**  **N/A**
- 2.5. **The zero indication must consist of at least the following minimum indications as appropriate:**
- 2.5.1. One digit to the left and all digits to the right of a decimal point. **Yes**  **No**  **N/A**
- 2.5.2. If a decimal point is not used, at least one active decade must be displayed. **Yes**  **No**  **N/A**
- 2.6. Totalizer values must be accurate to the nearest minimum interval with decimal points displayed or subordinate digits adequately differentiated from others, if applicable. **Yes**  **No**  **N/A**

**Code Reference: G-S.5.2.2. Digital Indication and Representation**

**Basic operating requirements for devices:**

- 2.7. All digital values of like value in a system shall agree with one another. **Yes**  **No**  **N/A**
- 2.8. A digital value coincides with its associated analog value to the nearest minimum graduation. **Yes**  **No**  **N/A**
- 2.9. Digital values shall round off to the nearest minimum unit that can be indicated or recorded. **Yes**  **No**  **N/A**
- 2.10. When a digital zero display is provided, the zero indication shall consist of at least one digit to the left and all digits to the right of the decimal point. **Yes**  **No**  **N/A**

**Agreement of indications shall be checked for several deliveries. The totalizer shall be checked for accuracy and agreement with individual deliveries and with other totalizers in the system.**

- 2.11. All digital values of like value in a system agree with one another. **Yes**  **No**  **N/A**
- 2.12. Digital values coincide with associated analog values to the nearest minimum graduation. **Yes**  **No**  **N/A**
- 2.13. Digital values "round off" to the nearest minimum unit that can be indicated or recorded. **Yes**  **No**  **N/A**
- 2.14. The device totalizer shall agree with the total of the individual deliveries and with other totalizers in the system. **Yes**  **No**  **N/A**

**Code Reference: G-S.5.2.3. Size and Character**

Digits used for comparable values must be uniform in size and character, but subordinate values may be displayed in different and less prominent digits than more significant values. The latter more likely occurs on analog devices. In digital indications, the digits are usually of uniform size throughout a particular display. The size of digits may differ for different quantities, for example, the quantity and unit price digits may be smaller than the total price digits.

2.15.  Yes  No  N/A

2.16. Indications and recorded representations shall be appropriately portrayed or designated.  Yes  No  N/A

**Code Reference: G-S.5.2.4. Values Defined**

2.17. Values shall be adequately defined by a sufficient number of figures, words, symbols, or combinations, which are uniformly placed so that they do not interfere with the accuracy of the reading.  Yes  No  N/A

**Code Reference: G-S.5.2.5. Permanence**

2.18. Indications, or recorded representations and their defining figures, words, and symbols shall be of such character that they will not tend to easily become obliterated or illegible. [What permanence quantities should be verified for electronic devices with graphical displays?](#)  Yes  No  N/A

**Code Reference: G-S.5.3., G-S.5.3.1. Values of Graduated Intervals or Increments**

2.19. Digital indications, and recorded representations shall be uniform in size, character, and value throughout any series. Quantity values shall be defined by the specific unit of measure in use.  Yes  No  N/A

2.20. Indications shall be uniform throughout any series.  Yes  No  N/A

2.21. Quantity values shall be identified by the unit of measure.  Yes  No  N/A

**Code Reference: G-S.5.4. Repeatability of Indications**

The quantity measured by a device shall be repeatable within tolerance for the same indication. One condition that may create a problem is that the value of the quantity division may be large relative to the tolerance. A delivery must be within tolerance wherever the delivery is stopped within the nominal indication of the test draft. Meters that may be at the tolerance limit may be out of tolerance at an extreme limit of the nominal quantity indication.

2.22. When a digital indicator is tested, the delivered quantity shall be within tolerance at any point within the quantity-value division for the test draft.  Yes  No  N/A

**Code Reference: G-S.5.6. Recorded Representations**

2.23. All recorded values shall be digital. (See also G-UR.3.3.)  Yes  No  N/A



**Code Reference: G-S.6. Marking, Operational Controls, Indications, and Features**

All operational controls, indications, and features shall be clearly and definitely identified. Nonfunctional keys and annunciators shall not be marked because their marking implies that the key or annunciator is functional and should be inspected or tested by the enforcement official. Keys and operator controls that are visible to a customer in a direct sale transaction shall be marked with words or symbols to the extent that they can be understood by the customer and aid in understanding the transaction. Keys that are visible only to the console operator need to be marked only to the extent that a trained operator can understand the function of each key.

- 2.25. All operational controls, indications, and features including switches, lights, displays, and push buttons shall be clearly and definitely identified. **Yes**  **No**  **N/A**
- 2.26. All dual function (multi-function) keys or controls shall be marked to clearly identify all functions. **Yes**  **No**  **N/A**
- 2.27. Non-functional controls and annunciators shall not be marked in the graphical display example they would be dimmed etc.) **Yes**  **No**  **N/A**

**Code Reference: G-S.7. Lettering, Readability**

- 2.28. Required markings and instructions shall be permanent and easily read. **Yes**  **No**  **N/A**

**Code Reference: G-S.8. Sealing Electronic Adjustable Components, and Provision for Sealing of Adjustable Components or Audit Trail**

- 2.29. Electronic adjustable components that affect the performance of a device shall provide for an approved means of security (e.g., data change audit trail) or for physically applying a security seal. These components include the following: (1) mechanical adjustment mechanism for meters, (2) the electronic calibration factor and automatic temperature compensator for electronic meter registers, (3) selection of pressure for density correction capability and correction values. **Yes**  **No**  **N/A**

The following philosophy and list of sealable parameters applies to provision for sealing all liquid-measuring devices.

An electronic data audit trail is a means of allowing a weights and measures inspector to review how many times any electronic adjustment, which affects the accuracy of a volume measurement has been changed. The information contained in the audit trail shall consist of a cumulative and non-destructible number (even if a power failure occurs) which increments each time any of the adjustments required to be sealed have been changed. The electronic data audit trail information shall be capable of being recalled by the official on the main display of the device.

**As a minimum, devices which use an audit trail to provide security for sealable parameters shall satisfy the following criteria and shall use the format set forth in Appendix A of the checklist for Liquid-Measuring Devices.**

## Philosophy for Sealing

### Typical Features to be Sealed

#### Principles for Determining Features to be Sealed

The need to seal some features depends upon:

- The ease with which the feature or the selection of the feature can be used to facilitate fraud; and
- The likelihood that the use of the feature will result in fraud not being detected.

Features or functions which the operator routinely uses as part of device operation, such as setting the unit prices on dispensers and maintaining unit prices in price look-up codes stored in memory, are not sealable parameters and shall not be sealed.

If a parameter (or set of parameters) selection would result in performance that would be obviously in error, such as the selection of parameters for different countries, then it is not necessary to seal the selection of these features.

If individual device characteristics are selectable from a "menu" or a series of programming steps, then access to the "programming mode" must be sealable. (Note: If an audit trail is the only means of security, then the audit trail shall update only after at least one sealable parameter has been changed; simply accessing the sealable parameters via a menu shall not update the audit trail.)

If a physical act, such as cutting a wire is required to change a parameter setting and physically repairing the cut is required to reactivate the parameter, then this physical repair process would be considered an acceptable way to select parameters without requiring a physical seal or an audit trail.

#### Typical Features and Parameters to be Sealed

The following provides examples of configuration and calibration parameters that are to be sealed. The examples are provided for guidance and are not intended to cover all possible parameters.

**Calibration Parameters:** Calibration parameters are those parameters whose values are expected to change as a result of accuracy adjustments. Examples include the following.

1. Measuring element adjustments where linearity corrections are used, e.g., flow rate 1 and meter factor 1, flow rate 2 and meter factor 2, etc.
2. Mass flow meter adjustments for zero adjustments (not simply setting the display to zero) and span settings.

**Configuration Parameters:** Configuration parameters are those parameters whose values are expected to be entered only once and not changed after all initial installation settings are made. Examples include the following.

1. Octane or other blend setting ratios
2. Temperature, pressure, density, and other sensor settings for zero, span, and offset values
3. Measurement units
4. Temperature compensation table, liquid coefficient of expansion, or compressibility factors or tables
5. Liquid density setting and allowable liquid density input range
6. Vapor pressures of liquids if used in calculations to establish the quantity

NTEP Committee 2015 Final Report  
Appendix D – 2014 Measuring Sector Meeting Summary  
Sub-Appendix A – Item 1: Draft Checklist for Testing Electronic Digital Indicators

7. Meter or sensor temperature compensation factors
- 8.
9. On/off status of automatic temperature, pressure, or density correction
10. Automatic or manual data input for sensors
- 11.
- 12.
13. Filtering constants

This publication is available free of charge from: <https://doi.org/10.6028/NIST.SP.1210>

<b>Liquid-Measuring Device Features and Parameters</b>	
<b>Typical Features or Parameters to be Sealed</b>	<b>Typical Features or Parameters Not Required to be Sealed</b>
Measuring element adjustment (both mechanical and electronic)	Analog-to-digital converters
Linearity correction values	Quantity division value (display resolution)
Measurement units (e.g., gallons to liters)	Double pulse counting
Octane blend setting for retail motor-fuel dispensers	Communications
Any tables or settings accessed by the software or manually entered to establish the quantity (e.g., specific gravity, pressure, etc.)	
Density ranges	
Temperature probes and temperature offsets in software (S.2.5.4 VT)	
Flow control settings, e.g., flow rates for slow-flow start, quantity for slow-flow start and stop	
Temperature compensating systems (on/off)	
As a point of clarification, the flow control settings referenced above are those controls typically incorporated into the installations of large-capacity meters (wholesale meters). The reference does not include the point at which retail motor-fuel dispenser's slow product flow during a prepaid transaction to enable the dispenser to stop at the preset amount.	

*Note: The above examples of adjustments, parameters, and features to be sealed are to be considered "typical" or "normal." This list may not be all inclusive. Some parameters other than those listed, which affect the metrological performance of the device, must be sealed. If listed parameters or other parameters, which may affect the metrological function of the device, are not sealed, the manufacturer must demonstrate that all settings comply with the most stringent requirements for the application of the device (i.e., the parameter does not affect compliance with NIST Handbook 44).*

**Category 1 Devices (Devices with No Remote Configuration Capability):**

- The device is sealed with a physical seal or it has an audit trail with two event counters (one for calibration, the second for configuration).      **Yes**  **No**  **N/A**
- A physical seal must be applied without exposing electronics.      **Yes**  **No**  **N/A**

NTEP Committee 2015 Final Report  
 Appendix D – 2014 Measuring Sector Meeting Summary  
 Sub-Appendix A – Item 1: Draft Checklist for Testing Electronic Digital Indicators

- Event counters are non-resettable and have a capacity of at least 000 to 999. **Yes**  **No**  **N/A**
- Event counters increment appropriately. **Yes**  **No**  **N/A**
- The audit trail information must be capable of being retained in memory for at least 30 days while the device is without power. **Yes**  **No**  **N/A**
- Accessing the audit trail information for review shall be separate from the calibration mode. **Yes**  **No**  **N/A**
- Accessing the audit trail information must not affect the normal operation of the device. **Yes**  **No**  **N/A**
- Accessing the audit trail information shall not require removal of any additional parts other than normal requirements to inspect the integrity of a physical security seal. (e.g., a key to open a locked panel may be required). **Yes**  **No**  **N/A**

**Category 2 Devices (Devices with Remote Configuration Capability but Controlled by Hardware):**

- The physical hardware enabling access for remote communication must be on-site. **Yes**  **No**  **N/A**
- The physical hardware must be sealable with a security seal or **Yes**  **No**  **N/A**
- The device must be equipped with at least two event counters: one for calibration, the second for configuration parameters **Yes**  **No**  **N/A** 
  - calibration parameters event counter
  - configuration parameters event counter
- Verify that all metrological relevant parameters are logged to Event Counter (S.2.2.) **Yes**  **No**  **N/A** 
  - Adequate provision must be made to apply a physical seal without exposing electronics. **Yes**  **No**  **N/A**
- Event counters are non-resettable and have a capacity of at least 000 to 999. **Yes**  **No**  **N/A**
- Event counters increment appropriately. **Yes**  **No**  **N/A**
- Event counters may be located either: **Yes**  **No**  **N/A** 
  - at the individual measuring device or
  - at the system controller
- If the counters are located at the system controller rather than at the individual device, means must be provided to generate a hard copy of the information through an on-site device. **Yes**  **No**  **N/A**

- An adequate number (see table below) of event counters must be available to monitor the calibration and configuration parameters of each individual device. Yes  No  N/A
  
- The device must either: Yes  No  N/A 
  - clearly indicate when it is in the remote configuration mode or
  - the device shall not operate while in the remote configuration mode.
  
- If capable of printing in the calibration mode, it must print a message that it is in the calibration mode. Yes  No  N/A
  
- The audit trail information must be capable of being retained in memory for at least 30 days while the device is without power. Yes  No  N/A
  
- The audit trail information must be readily accessible and easily read. Yes  No  N/A

<b>Minimum Number of Counters Required</b>		
	<b>Minimum Counters Required for Devices Equipped with Event Counters</b>	<b>Minimum Event Counter(s) at System Controller</b>
Only one type of parameter accessible (calibration or configuration)	One (1) event counter	One (1) event counter for each separately controlled device, or one (1) event counter, if changes are made simultaneously.
Both calibration and configuration parameters accessible	Two (2) event counters	Two (2) event counters for each separately controlled device, or two (2) or more event counters if changes are made to all controlled devices simultaneously.

**Category 3 Devices (Devices with Unlimited Remote Configuration Capability):**

Category 3 devices have virtually unlimited access to sealable parameters or access is controlled through a password.

- The device must either: Yes  No  N/A 
  - Clearly indicate when it is in the remote configuration mode, or
  - The device shall not operate while in the remote configuration mode
  
- The device is equipped with an event logger Yes  No  N/A

- Verify that all metrological relevant parameters are logged to Audit trail (S.2.2.) **Yes**  **No**  **N/A**   
**Yes**  **No**  **N/A** 
  - The event logger automatically retains the identification of the parameter changed, the date and time of the change, and the new value of the parameter.
- Event counters are nonresettable and have a capacity of at least 000 to 999. **Yes**  **No**  **N/A**
- The system is designed to attach a printer, or other communications device (i.e., Ethernet, Serial Communications, USB, Wi-Fi, Bluetooth etc.) which will allow an interface to a printer or allow for the creation of a digital copy (file) for future reference. **Yes**  **No**  **N/A**
- The audit trail information must be capable of being retained in memory for at least 30 days while the device is without power. **Yes**  **No**  **N/A**
- The event logger must have a capacity to retain records equal to ten times the number of sealable parameters in the device, but not more than 1000 records are required. **Yes**  **No**  **N/A**
- The event logger drops the oldest event when the memory capacity is full and a new entry is saved. **Yes**  **No**  **N/A**
- Describe the method used to seal the device or access the audit trail information.

---



---

**Code Reference: G-UR.1.1. Suitability of Equipment**

A register/indicator must be properly designed and have sufficient capacity to be suitable to use in a particular application. A register/indicator must measure the appropriate characteristics of a commodity to accurately determine the quantity, have sufficient capacity to indicate the quantity measured and the associated total price if it is a computing device. The register/indicator must have the proper capacity to operate over the actual frequency range for the application, and the device must have a quantity division appropriate for the application.

The equipment is suitable for its intended application. **Remove?** **Yes**  **No**  **N/A**

2.26.	<p><b>Simulator tests: All tests shall have a minimum of 10,000 pulses applied to the device for each test. Test with a minimum of two API/Density settings</b></p> <p><u><a href="#">Notes, items that need to be added to table/Checklist:</a></u></p> <p><u><a href="#">a. Information needs to be added to capture different K-Factor values</a></u></p> <p><u><a href="#">b. All API tables to be included on certificate shall be verified</a></u></p> <p><u><a href="#">c. Verify extreme endpoints and a center point of each table</a></u></p>
-------	---

NTEP Committee 2015 Final Report  
Appendix D – 2014 Measuring Sector Meeting Summary  
Sub-Appendix A – Item 1: Draft Checklist for Testing Electronic Digital Indicators

<b>Product:</b>		<b>Meter Factor:</b>	<b>K Factor:</b>	
1	Test with liquid temperature between 55 F – 65 F at the manufactures rated maximum frequency/pulse rate.	API Gravity/Density: Temperature:		<b>Yes</b> <input type="checkbox"/> <b>No</b> <input type="checkbox"/> <b>N/A</b> <input type="checkbox"/>
2	Test with liquid temperature between 55 F – 65 F at manufactures rated minimum frequency/pulse rate.	API Gravity/Density: Temperature:		<b>Yes</b> <input type="checkbox"/> <b>No</b> <input type="checkbox"/> <b>N/A</b> <input type="checkbox"/>
3	Test with liquid temperature below 35 F at manufactures rated maximum frequency/pulse rate.	API Gravity/Density: Temperature:		<b>Yes</b> <input type="checkbox"/> <b>No</b> <input type="checkbox"/> <b>N/A</b> <input type="checkbox"/>
4	Test with liquid temperature below 35 F at manufactures rated minimum frequency/pulse rate.	API Gravity/Density: Temperature:		<b>Yes</b> <input type="checkbox"/> <b>No</b> <input type="checkbox"/> <b>N/A</b> <input type="checkbox"/>
5	Test with liquid temperature above 100 F at manufactures rated maximum frequency/pulse rate.	API Gravity: Temperature:		<b>Yes</b> <input type="checkbox"/> <b>No</b> <input type="checkbox"/> <b>N/A</b> <input type="checkbox"/>
6	Test with liquid temperature above 100 F at manufactures rated minimum frequency/pulse rate.	API Gravity: Temperature:		<b>Yes</b> <input type="checkbox"/> <b>No</b> <input type="checkbox"/> <b>N/A</b> <input type="checkbox"/>
7	Test with liquid temperature between 55 F – 65 F at the manufactures rated maximum frequency/pulse rate.	API Gravity/Density: Temperature:		<b>Yes</b> <input type="checkbox"/> <b>No</b> <input type="checkbox"/> <b>N/A</b> <input type="checkbox"/>
8	Test with liquid temperature between 55 F – 65 F at manufactures rated minimum frequency/pulse rate.	API Gravity/Density: Temperature:		<b>Yes</b> <input type="checkbox"/> <b>No</b> <input type="checkbox"/> <b>N/A</b> <input type="checkbox"/>
9	Test with liquid temperature below 35 F at manufactures rated maximum frequency/pulse rate.	API Gravity/Density: Temperature:		<b>Yes</b> <input type="checkbox"/> <b>No</b> <input type="checkbox"/> <b>N/A</b> <input type="checkbox"/>
10	Test with liquid temperature below 35 F at manufactures rated minimum frequency/pulse rate.	API Gravity/Density: Temperature:		<b>Yes</b> <input type="checkbox"/> <b>No</b> <input type="checkbox"/> <b>N/A</b> <input type="checkbox"/>
11	Test with liquid temperature above 100 F at manufactures rated maximum frequency/pulse rate.	API Gravity/Density: Temperature:		<b>Yes</b> <input type="checkbox"/> <b>No</b> <input type="checkbox"/> <b>N/A</b> <input type="checkbox"/>
12	Test with liquid temperature above 100 F at manufactures rated minimum frequency/pulse rate.	API Gravity/Density: Temperature:		<b>Yes</b> <input type="checkbox"/> <b>No</b> <input type="checkbox"/> <b>N/A</b> <input type="checkbox"/>

This publication is available free of charge from: <https://doi.org/10.6028/NIST.SP.1210>



THIS PAGE INTENTIONALLY LEFT BLANK

## Appendix D/Sub-Appendix B

### National Type Evaluation Program

#### Software Maintenance and Reconfiguration Excerpts from 2013 Measuring Sector Summary

The following was excerpted from the 2013 Measuring Sector agenda on Software Maintenance and Reconfiguration and is provided to give background on the previous discussions of this item.

After the software is completed, what do the manufacturers use to secure their software? The following items were reviewed by the Sector. *Note that agenda Item 3 also contains information on Verified and Traced updates and Software Log.*

1. Verify that the update process is documented (OK).
2. For traced updates, installed Software is authenticated and checked for integrity.

Technical means shall be employed to guarantee the authenticity of the loaded software (i.e., that it originates from the owner of the type approval certificate). This can be accomplished (e.g., by cryptographic means like signing). The signature is checked during loading. If the loaded software fails this test, the instrument shall discard it and either use the previous version of the software **or become inoperative**.

Technical means shall be employed to guarantee the integrity of the loaded software (i.e., that it has not been inadmissibly changed before loading). This can be accomplished (e.g., by adding a checksum or hash code of the loaded software and verifying it during the loading procedure). If the loaded software fails this test, the instrument shall discard it and either use the previous version of the software **or become inoperative**.

Examples are not limiting or exclusive.

3. Verify that the sealing requirements are met.

The Sector asked, “What sealing requirements are we talking about”?

This item is **only** addressing the **software update**; it can be either verified or traced. It is possible that there are two different security means, one for protecting software updates (software log) and one for protecting the other metrological parameters (Category I, II, or III method of sealing). Some examples provided by the Sector members include but are not limited to:

Physical Seal, software log

Category III method of sealing can contain both means of security.

4. Verify that if the upgrade process fails, the device is inoperable or the original software is restored.

The question before the group is, “Can this be made mandatory”?

The manufacturer shall ensure by appropriate technical means (e.g., an audit trail) that traced updates of metrologically significant software are adequately traceable within the instrument for subsequent verification and surveillance or inspection. This requirement enables inspection authorities, which are responsible for the metrological surveillance of legally controlled instruments, to back-trace traced updates of metrologically

significant software over an adequate period of time (that depends on national legislation). The statement in italics will need to be reworded to comply with US weights and measures requirements.

The Sector **agreed** that the two definitions below for Verified update and Traced update were acceptable.

**Verified Update**

A verified update is the process of installing new software where the security is broken and the device must be re-verified. Checking for authenticity and integrity is the responsibility of the owner/user.

**Traced Update**

A traced update is the process of installing new software where the software is automatically checked for authenticity and integrity, and the update is recorded in a software update log or audit trail.

*Note: It's possible that the Philosophy of Sealing section of NCWM Publication 14 may already address the above IF the definitions of Verified and Traced Updates (and the statement below) were to be added. The contrary argument was that it may be better to be explicit).*

**Use of a Category 3 audit trail is required for a Traced Update. A log entry representing a traced software update shall include the software identification of the newly installed version.**

The Sector recommended consolidating the definitions with the above statement thus:

**Verified Update**

A verified update is the process of installing new software where the security is broken and the device must be re-verified. Checking for authenticity and integrity is the responsibility of the owner/user.

**Traced Update**

A traced update is the process of installing new software where the software is automatically checked for authenticity and integrity, and the update is recorded in a ~~software update log or~~ Category 3 audit trail. The audit trail entry shall include the software identification of the newly installed version.

In 2012, the Sector recommended that as a first step, the following be added to NCWM Publication 14:

**The updating of metrologically significant software, including software that checks the authenticity and integrity of the updates, shall be considered a sealable event.**

Mr. Truex, NTEP Administrator, indicated his opinion that the above sentence is unnecessary since it's self-evident. It was agreed by the group however to ask the other sectors for feedback on the value of this addition.

Though the Sector is currently considering only the single sentence be incorporated into NCWM Publication 14 for the time being, ultimately, the Sector may wish to advance the remaining language of the original item submission.

**Discussion:**

The Sector had no information indicating that the other Sectors had yet been approached for feedback on the value of the addition of the proposed sentence.

**Recommendation:**

The Software Sector is requesting each of the NTETC Sectors review and provide feedback on the following draft language it developed for consideration of adding it to NCWM Publication 14:

**The updating of metrologically significant software, including software that checks the authenticity and integrity of the updates, shall be considered a sealable event.**

Should the MS agree this language is appropriate, it might then consider where within NCWM Publication 14 Liquid-Measuring Devices this sentence should be inserted. The Sector might consider including it in the appropriate sealing sections of NCWM Publication 14 relating to audit trails. For example:

- LMD Checklist:
  - General, Section 2. Graduations, Indications and Recorded Representations, Code Reference G-S.8.
  - RMFDs, Section 9. Measuring Elements, Code Reference S.2.2. Provision for Sealing and Code Reference: S.2.2.1. Multiple Measuring Devices with a Single Provision for Sealing
  - Wholesale & Loading Rack Meters, Section 19. Measuring Elements, Code Reference S.2.2. Provision for Sealing and Code Reference: S.2.7.3. Provision for Sealing - Automatic Temperature Compensation
  - Vehicle-Tank Meters, Section 26. Measuring Elements, Code Reference S.2.2. Provision for Sealing and Code Reference: S.2.6.2. Provision for Sealing
  - LPG & NH<sub>3</sub> Meters, Section 31. Measuring Elements, Code Reference S.2.2. Provision for Sealing
  - Mass Flow Meters, Section 36. Measuring Elements, Code Reference: S.3.5. Provision for Sealing
  - Water Meters Checklist, Section 45 Measuring Elements, Code Reference: S.2.1. Provision for Sealing
  - Hydrogen Gas Measuring Devices, Section 51. Design of Measuring Elements and Measuring Systems, Code Reference: S.3.3. Provision for Sealing
  - LMD Checklist Appendix B Requirements for Metrological Audit Trails
- ECR-LMD Checklist
  - Section 4. Provisions for Sealing, Code Reference: G-S.8. Provision for Sealing Electronic Adjustable Components

The Software Sector is also requesting feedback from the other NTETC Sectors regarding whether or not additional language such as the following is needed in NCWM Publication 14 to make clear that an existing audit trail should be protected during a software update. In the background information provided for this item, it was noted that the Software Sector noted that this does already seem to be addressed in the Requirements for Metrological Audit Trails in NCWM Publication 14.

1. The audit trail data shall be:

- 3.5.1.1.1. Stored in non-volatile memory and shall be retained for at least 30 days if power is removed from the device; **AND**
- 3.5.1.1.2. Protected from unauthorized erasure, substitution, or modification.

**Discussion:**

At the 2013 Measuring Sector meeting, Mr. Jim Truex (NTEP Director) described feedback from the Weighing Sector and Grain Sectors in their discussions of this item. Mr. Dennis Beattie (Measurement Canada) noted that the software described in the recommendation policies the authenticity of the existing software in an electronic weighing or measuring system. This software would be separate from audit trail information and the event of a change in software would be considered a metrologically significant event. In discussing this item, some NCWM Publication 14.

**Decision:**

The 2013 Measuring Sector rejected the recommendation to include the proposed changes in NCWM Publication 14. Measuring Sector manufacturers were unable to add any contributions during the meeting that would lead to agreement to include the proposed changes in NCWM Publication 14; however, they committed to the task of taking this issue to their companies' software engineers to flesh out the proposal. The Sector agreed to carry this item over to its next meeting to allow the manufacturers time to study this issue and bring back alternative(s) to consider.

## Appendix D/Sub-Appendix C

### National Type Evaluation Program

#### Applying Permanence Test Criteria - Examples and Testing Requirements

The following examples and testing requirements were developed by Mr. John Roach (CDFA DMS, NTEP Laboratory) to illustrate and clarify the technical policy and field evaluation and permanence test criteria. These examples and testing requirements were discussed, amended, and agreed upon by the 2014 NTEP Measuring Sector.

##### Example A:

- A CNG RMFD metering system uses a previously evaluated mass flow meter covered by a separate CC.
- The CC for the CNG RMFD included both initial and permanence testing over the flow range listed on the CNG RMFD CC.
- The meter used in the CNG RMFD uses the *same transmitter model* as that covered by the separate meter CC.
- The CC for the CNG RMFD metering system currently covers a flow range of: 3.0 to 75 lb/min
- The CC for the previously evaluated meter covers flow rates of: 2.5 to 130 lb/min
- The CNG RMFD manufacturer wants the CNG RMFD system to include flow rates of: 2.5 to 130 lb/min

##### Testing Requirements:

The requested maximum flow rate does not extend beyond the flow rate covered under the CC for the meter. However, the holder of the CC for the meter owns the rights to the test results from that CC.

If the holder of the meter CC provides written permission for the CNG RMFD to use the results from the testing conducted for the meter, the CNG RMFD CC may be expanded to include the higher flow rate without additional testing.

If permission is not obtained, then additional testing, including permanence testing (including throughput as specified for mass flow meters) is required to include the extended flow rate.

##### Example B:

- A CNG RMFD metering system uses a previously evaluated mass flow meter covered by a separate CC.
- The CC for the CNG RMFD included both initial and permanence testing over the flow range listed on the CNG RMFD CC.
- The meter used in the CNG RMFD uses the *same transmitter model* as that covered by the separate meter CC.
- The CC for the CNG RMFD metering system currently covers a flow range of: 3.0 to 75 lb/min
- The CC for the previously evaluated meter covers flow rates of: 2.5 to 130 lb/min
- The CNG RMFD manufacturer wants the CNG RMFD system to include flow rates of: 2.5 to 250 lb/min

**Testing Requirements:**

The requested maximum flow rate extends beyond the flow rate covered under the CC for the meter.

Based on Technical Policy E “Meter Sizes to be Included on a Certificate of Conformance,” additional testing, including permanence testing (including throughput as specified for mass flow meters) is required to include the extended flow rate.

**Example C:**

- A CNG RMFD metering system uses a previously evaluated mass flow meter covered by a separate CC.
- The CC for the CNG RMFD included both initial and permanence testing over the flow range listed on the CNG RMFD CC.
- The meter used in the CNG RMFD uses a *different transmitter model* than the meter covered by the separate meter CC.
- The CC for the CNG RMFD metering system currently covers a flow range of: 3.0 to 75 lb/min
- The CC for the previously evaluated meter covers flow rates of: 2.5 to 130 lb/min
- The CNG RMFD manufacturer wants the CNG RMFD system to include flow rates of: 2.5 to 130 lb/min

**Testing Requirements:**

Testing requirements must consider both the extension of the flow rate and the change in transmitter.

**Transmitter Change.** The transmitter used in the CNG RMFD is different. The changing of the transmitter is significant and this would be considered a new meter. Thus, a full permanence test is required for the CNG RMFD using the new transmitter at the higher flow rate.

**Flow Rate Extension.** With regard for the request extension of the flow rate, the requested maximum flow rate does not extend beyond the flow rate covered under the CC for the meter. However, the holder of the CC for the meter owns the rights to the test results from that CC.

If the holder of the meter CC provides written permission for the CNG RMFD to use the results from the testing conducted for the meter, the CNG RMFD CC may be expanded to include the higher flow rate with only the 30-day permanence test described above.

If permission is not obtained, then full permanence testing (including throughput as specified for mass flow meters) is required to include the extended flow rate.

**Example D:**

- A CNG RMFD metering system uses a previously evaluated mass flow meter covered by a separate CC.
- The CC for the CNG RMFD included both initial and permanence testing over the flow range listed on the CNG RMFD CC.
- The meter used in the CNG RMFD uses a *different transmitter model* than the meter covered by the separate meter CC.

- The CC for the CNG RMFD metering system currently covers a flow range of: 3.0 to 75 lb/min
- The CC for the previously evaluated meter covers flow rates of: 2.5 to 130 lb/min
- The CNG RMFD manufacturer wants the CNG RMFD system to include flow rates of: 2.5 to 250 lb/min

**Proposed Testing Requirements:**

Testing requirements must consider both the extension of the flow rate and the change in transmitter.

**Transmitter Change.** The transmitter used in the CNG RMFD is different. The changing of the transmitter is significant and this would be considered a new meter. Thus, a full permanence test is required for the CNG RMFD using the new transmitter at the higher flow rate. And the flow rate change will necessitate a full permanence test in this example.

**Flow Rate Change.** The requested maximum flow rate extends *beyond* the flow rate covered under the CC for the meter.

Based on Technical Policy E “Meter Sizes to be Included on a Certificate of Conformance,” additional testing, including permanence testing (including throughput as specified for mass flow meters) is required to include the extended flow rate.



THIS PAGE INTENTIONALLY LEFT BLANK

## Appendix D/Sub-Appendix D

### National Type Evaluation Program

#### 2014 S&T Agenda Proposals to Change LPG Code

332-1 D S.1.4.3. Provisions for Power Loss; S.1.5.1.1. Unit Price; S.1.5.1.2. Product Identity; S.1.6. For Retail Motor Vehicle Fuel Devices Only; S.1.7. For Wholesale Devices Only; UR.2.7. Unit Price and Product Identity; and UR.2.8. Computing Device.

**Source:**

California Department of Food and Agriculture Division of Measurement Standards (2014)

**Purpose:**

Add similar Specifications and User Requirements for other retail motor-fuel devices to Handbook 44 Section 3.32. Liquefied Petroleum Gas (LPG) and Anhydrous Liquid-Measuring Devices Code similar to those in Section 3.30. Liquid-Measuring Devices, Section 3.37. Mass flow Meters, and Section 3.39 Hydrogen-Gas Measuring Devices Tentative Code.

**Item Under Consideration:**

Amend NIST Handbook 44, Liquefied Petroleum Gas and Anhydrous Liquid-Measuring Devices Code as follows:

**S.1.4. For Retail Devices Only (No Change)**

S.1.4.1. Indication of Delivery (No Change)

S.1.4.2. Return to Zero (No Change)

**S.1.4.3. Provisions for Power Loss.**

**S.1.4.3.1. Transaction Information.**

**(a) In the event of a power loss, a computing retail liquefied petroleum dispensing device shall display the information needed to complete any transaction in progress at the time of the power loss (such as the quantity and unit price, or sales price) shall be determinable for at least 15 minutes at the dispenser or at the console if the console is accessible to the customer.**

**(b) In the event of a power loss, both an electronic digital retail non-computing stationary liquefied petroleum gas dispenser and a vehicle-mounted electronic digital liquefied petroleum gas dispenser shall display the information needed to complete any transaction in progress at the time of the power loss.**

**S.1.4.3.2. User Information. – The device memory shall retain information on the quantity of fuel dispensed and the sales price totals during power loss.**

**S.1.5. For Stationary Retail Devices Only.**

**S.1.5.1. Display of Unit Price and Product Identity. – In a device of the computing type, means shall be provided for displaying on each face of the device the unit price at which the device is set to compute or to**

**deliver as the case may be, and there shall be conspicuously displayed on each side of the device the identity of the product that is being dispensed. If a device is so designed as to dispense more than one grade, brand, blend, or mixture of product, the identity of the grade, brand, blend, or mixture being dispensed shall also be displayed on each face of the device.**

**S.1.5.1.1. Unit Price.**

- (a) **A computing or money-operated device shall be able to display on each face the unit price at which the device is set to compute or to dispense.**
- (b) **Except for dispensers used exclusively for fleet sales, other price contract sales, and truck refueling (e.g., truck stop dispensers used only to refuel trucks), whenever a grade, brand, blend, or mixture is offered for sale from a device at more than one unit price, then all of the unit prices at which that product is offered for sale shall meet the following conditions:**
- (1) **For a system that applies a discount prior to the delivery, all unit prices shall be displayed or shall be capable of being displayed on the dispenser through a deliberate action of the purchaser prior to the delivery of the product. It is not necessary that all of the unit prices for all grades, brands, blends, or mixtures be simultaneously displayed prior to the delivery of the product.**
- (2) **For a system that offers post-delivery discounts on fuel sales, display of pre-delivery unit price information is exempt from (b)(1), provided the system complies with S.1.6.8. Recorded Representations for Transactions Where a Post-Delivery Discount(s) is Provided.**

**Note: When a product is offered at more than one unit price, display of the unit price information may be through the deliberate action of the purchaser: 1) using controls on the device; 2) through the purchaser's use of personal or vehicle-mounted electronic equipment communicating with the system; or 3) verbal instructions by the customer.**

**S.1.5.1.2. Product Identity.**

- (a) **A device shall be able to conspicuously display on each side the identity of the product being dispensed.**
- (b) **A device designed to dispense more than one grade, brand, blend or mixture of product also shall be able to display on each side the identity of the grade, brand, blend, or mixture being dispensed.**

**S.1.6. For Wholesale Devices Only For Retail Motor Vehicle Fuel Devices Only**

**S.1.6.1. Zero-Set-Back Interlock, Retail Motor-Fuel Devices. – A device shall be constructed so that:**

- (a) **after a delivery cycle has been completed by moving the starting lever to any position that shuts off the device, an automatic interlock prevents a subsequent delivery until the indicating elements, and recording elements if the device is equipped and activated to record, have been returned to their zero positions;**
- (b) **the discharge nozzle cannot be returned to its designed hanging position (that is, any position where the tip of the nozzle is placed in its designed receptacle and the lock can be inserted) until the starting lever is in its designed shut-off position and the zero-set-back interlock has been engaged; and**

**(c) in a system with more than one dispenser supplied by a single pump, an effective automatic control valve in each dispenser prevents product from being delivered until the indicating elements on that dispenser are in a correct zero position.**

**S.1.6.2. Provisions for Power Loss.**

**S.1.6.2.1. Transaction Information. – In the event of a power loss, the information needed to complete any transaction in progress at the time of the power loss (such as the quantity and unit price, or sales price) shall be determinable for at least 15 minutes at the dispenser or at the console if the console is accessible to the customer.**

**S.1.6.2.2. User Information. – The device memory shall retain information on the quantity of fuel dispensed and the sales price totals during power loss.**

**S.1.6.3. Display of Unit Price and Product Identity. Except for fleet sales and other price contract sales, a motor vehicle fuel dispenser used to refuel vehicles shall be of the computing type and shall indicate the quantity, the unit price, and the total price of each delivery. The dispenser shall display the volume measured for each transaction.**

**S.1.6.4. Totalizers for Retail Motor-Fuel Dispensers. – Retail motor-fuel dispensers shall be equipped with a nonresettable totalizer for the quantity delivered through the metering device.**

**S.1.6.5. Money-Value Divisions. – A computing type shall comply with the requirements of paragraph G-S.5.5. Money-Values, Mathematical Agreement, and the total price computation shall be based on quantities not exceeding 0.05 L for devices indicating in metric units and 0.01 gal intervals for devices indicating in inch-pound units.**

**S.1.7. For Wholesale Devices Only. (Renumbered - No Change)**

**UR.2.7. Unit Price and Product Identity.**

**(a) The following information shall be conspicuously displayed or posted on the face of a retail dispenser used in direct sale:**

**(1) except for unit prices resulting from any post-delivery discount and dispensers used exclusively for fleet sales, other price contract sales, and truck refueling (e.g., truck stop dispensers used only to refuel trucks), all of the unit prices at which the product is offered for sale; and**

**(2) in the case of a computing type or money-operated type, the unit price at which the dispenser is set to compute.**

**Provided that the dispenser complies with S.1.5.1.1. Display of Unit Price, it is not necessary that all the unit prices for all grades, brands, blends, or mixtures be simultaneously displayed or posted.**

**(b) The following information shall be conspicuously displayed or posted on each side of a retail dispenser used in direct sale:**

**(1) the identity of the product in descriptive commercial terms; and**

**(2) the identity of the grade, brand, blend, or mixture that a multi-product dispenser is set to deliver.**

**UR.2.8 Computing Device – Any computing device used in an application where a product or grade is offered for sale at one or more unit prices shall be used only for sales for which the device computes and displays the sales price for the selected transaction.**

**The following exceptions apply:**

**(a) Fleet sales and other price contract sales are exempt from this requirement.**

**(b) A truck stop dispenser used exclusively for refueling trucks is exempt from this requirement provided that:**

**(1) all purchases of fuel are accompanied by a printed receipt of the transaction containing the applicable price per gallon, the total gallons delivered, and the total price of the sale; and**  
**(Added 1993)**

**(2) unless a dispenser complies with S.1.6.4.1. Display of Unit Price, the price posted on the dispenser and the price at which the dispenser is set to compute shall be the highest price for any transaction which may be conducted.**  
**(Added 1993)**

**(c) A dispenser used in an application where a price per unit discount is offered following the delivery is exempt from this requirement, provided the following conditions are satisfied:**

**(1) the unit price posted on the dispenser and the unit price at which the dispenser is set to compute shall be the highest unit price for any transaction;**

**(2) all purchases of fuel are accompanied by a printed receipt recorded by the system for the transaction containing:**

**a. the product identity by name, symbol, abbreviation, or code number;**

**b. transaction information as shown on the dispenser at the end of the delivery and prior to any post-delivery discount including the:**

**1. total volume of the delivery;**

**2. unit price; and**

**3. total computed price of the fuel sale prior to post-delivery discounts being applied.**

**c. an itemization of the post-delivery discounts to the unit price; and**

**d. the final total price of the fuel sale.**

**For systems equipped with the capability to issue an electronic receipt, the customer may be given the option to receive the receipt electronically (e.g., via cell phone, computer, etc.)**

**Background/Discussion:**

NCWM Publication 14 checklist for Liquefied Natural Gas (LPG) Retail Motor Fuel Devices verifies compliance with specifications, such as: “Power Loss” (which requires a 15-minute power back up) and “Zero-Setback Interlocks.” However, these specifications are not located in Section 3.32. of NIST Handbook 44.

There are LPG devices with NTEP Certificates of Conformance that meet current “power loss” and “zero-setback interlock” requirements. However, there are other LPG retail motor-fuel devices in the field that consist of an assembly of separable, compatible, and type-certified LPG measuring and indicating elements, key/card lock systems that do not meet the power loss and interlock requirements because those requirements are not within the LPG Code and have not been submitted for type evaluation. This creates unfair competition with holders of type certifications for LPG retail dispensers.

There are newer LPG dispensers coming in to use, where measuring, indicating, and computing elements are assembled in Gilbarco retail motor fuel dispenser housings. These LPG devices serve as both propane bottle fillers and as retail motor fuel devices using separate hoses and nozzles on a dispenser. Many of these dispensers, while they do have a good safety history, are not assembled in compliance with safety standards such as UL 495 or 1238, or NFPA 50. Nor are they typically installed in accordance with NFPA 30A or NFPA 70.

Existing retail LPG dispensers can be adapted to fuel LPG-powered motor vehicles by adding a simple adaptor, which attaches to the LPG nozzle on the dispenser's hose. There are currently five active and two inactive NTEP Certificates of Conformance for LPG retail motor-fuel dispensers listed in the NCWM Database.

At the 2014 NCWM Interim Meeting, Ms. Juana Williams (NIST, OWM) commented that OWM believes these changes will better align the LMD and LPG Code with regard to retail dispensing systems. OWM suggests that the following specific items be considered as the item is further developed:

**Nonretroactive Status:**

OWM notes that some of the paragraphs in the original proposal are suggested as nonretroactive requirements. In reviewing these paragraphs, consideration should be given as to the appropriate nonretroactive date to propose and whether or not the effective dates provided should mirror the effective dates of corresponding paragraphs in the LMD Code.

**S.1.4.3. Provisions for Power Loss:**

OWM questions whether or not the provisions for power loss in the proposed paragraph "S.1.4.3.1. Transaction Information" should be restricted to "computing" retail LPG dispensers. This corresponding requirement applies to *all* retail devices in the LMD Code, not just computing-type devices. If a power loss occurs during the use of a digital volume-only retail LPG dispenser, it would seem appropriate to require provisions to ensure that the quantity information can be recalled so that the transaction can be completed. It isn't clear why there would need to be a distinction between vehicle-mounted and stationary applications.

Additionally, the language proposed in S.1.4.3.1. Transaction Information has some language that doesn't read correctly. OWM offers the following alternative:

**S.1.4.3. Provisions for Power Loss.**

**S.1.4.3.1. Transaction Information. – In the event of a power loss, the information needed to complete any transaction in progress at the time of the power loss (such as the quantity and unit price, or sales price) shall be determinable for at least 15 minutes at the dispenser or at the console if the console is accessible to the customer.**

**S.1.4.3.2. User Information. – The device memory shall retain information on the quantity of fuel dispensed and the sales price totals during power loss.**

**S.1.5.1.1. Unit Price** – Consideration should be given to whether or not provision needs to be made for "blends" of product for this application. Additionally, the references to paragraph S.1.6.8. refers to an LMD Code paragraph; this reference should be deleted and, perhaps, replaced with a corresponding paragraph of the LPG Code.

**Post-Delivery Discounts:** For consistency with the LMD Code, the Committee may wish to consider whether provisions for post-delivery discounts should be added to the LPG Code.

**S.1.4.1. Indication of Delivery:**

OWM suggests that the Committee consider modifying paragraph S.1.4.1. Indication of Delivery as follows so that it mirrors the corresponding paragraph (S.1.6.1. Indication of Delivery) in the LMD Code, both in language and in

the requirement for electronic devices to inhibit indications until fueling conditions ensure that the delivery starts on zero.

**S.1.4.1. Indication of Delivery.** – A retail device shall ~~be constructed to show~~ automatically show on its face the initial zero condition and the ~~amounts~~ quantity delivered up to the nominal capacity of the device. However, the following requirements shall apply:

For electronic devices manufactured prior to January 1, 2006, the first 0.03 L (or 0.009 gal) of a delivery and its associated total sales price need not be indicated.

For electronic devices manufactured on or after January 1, 2006, the measurement, indication of delivered quantity, and the indication of total sales price shall be inhibited until the fueling position reaches conditions necessary to ensure that the delivery starts at zero.

[Nonretroactive as of January 1, 2006]

(Amended 2014)

OWM suggests the Committee consider what nonretroactive dates, if any, should be associated with this paragraph.

**S.1.6.2. Provisions for Power Loss:** It would seem that the provisions for power loss are already addressed in the proposed paragraph S.1.4.3. Power Loss. Therefore, OWM would suggest deleting S.1.6.2. and its subparagraphs S.1.6.2.1. and S.1.6.2.2.

**S.1.6.3. Display of Unit Price:** This proposed paragraph is logical. However, OWM questions whether the last sentence regarding volume display is needed given that the “quantity” is already required in the previous sentence.

**UR.2.7.(a)(2) Unit Price and Product Identity Wholesale:** The word “device” is missing after the word “type.”

**UR.2.8. Computing Device:** Delete “Added” dates from parts (b)(1) and (b)(2).

This paragraph may also be impacted by action on Items 310-2 and 330-1, which address requirements for recorded representations in the General and LMD Codes. Should the proposal in Item 310-2 to reference the use of electronic receipts be adopted, the corresponding reference in this proposed paragraph (UR.2.8.) should be deleted.

**Agreement Between Indications on Auxiliary Elements:** Consideration should be given to including a paragraph corresponding to LMD Code paragraph S.1.6.6. which addresses agreement of indications with auxiliary elements such as consoles.

**General:** As part of this overall proposal, consideration should be given to modifying other sections of the LPG Code to mirror the LMD Code more exactly. This could be done by the Technical Advisor and presented to the submitter as the item is further developed if that would be helpful.

The Committee heard comments from Mr. John Young (Yolo County, California) in support of the proposed changes. The Committee heard comments from OWM (see above) and Mr. Rich Miller (FMC) regarding the need to more closely examine the power loss requirements and how these apply to specific categories of LPG metering systems. Mr. Miller noted concern in particular that separate batteries have been required for some vehicle-mounted applications in Europe and this has proven problematic for companies.

The Committee supports the objective of making changes to align the LPG and the LMD Code with respect to requirements for retail motor-fuel dispensing applications. Based on the comments received, the Committee believes that additional work is needed before considering the proposal for voting and decided to designate the item as a “Developing” Item to allow the submitter to address the points raised.

**Regional Associations Comments:**

The CWMA believes this item is sufficiently developed and forwarded it to NCWM, recommending that it be a Voting item.

The WWMA believes the proposal has merit and contains a complete proposal addressing the issues. The WWMA believes more time is needed for input from other stakeholders and regional associations. The WWMA forwarded this item to NCWM and recommended that it be an Informational Item.

SWMA did not receive any comments opposing the item if the section is the same as the LMD Code. The SWMA recommended the item be moved forward to the NCWM as a Voting Item.



THIS PAGE INTENTIONALLY LEFT BLANK

## Appendix E

# National Type Evaluation Program (NTEP) Software Sector Meeting Summary

August 27 - 28, 2014  
Atlanta, Georgia

### INTRODUCTION

The charge of the NTEP Software Sector is important in providing appropriate type evaluation criteria for software-based weighing or measuring device based on specifications, tolerances and technical requirements of NIST Handbook 44, *Specifications, Tolerances, and Other Technical Requirements for Weighing and Measuring Devices*, Section 1.10. General Code, Section 2 for weighing devices, Section 3 for liquid and vapor measuring devices, and Section 5 for taximeters, grain analyzers, and multiple dimension measuring devices. The Sector’s recommendations are presented to the National Type Evaluation Program (NTEP) Committee each January for approval and inclusion in NCWM Publication 14, *Technical Policy, Checklists, and Test Procedures*, for national type evaluation.

The Sector is also called upon occasionally for technical expertise in addressing difficult NIST Handbook 44 issues on the agenda of the National Conference on Weights and Measures (NCWM) Specifications and Tolerances (S&T) Committee. Sector membership includes industry, NTEP laboratory representatives, technical advisors, and the NTEP Administrator. Meetings are held annually, or as needed and are open to all NCWM members and other registered parties.

Proposed revisions to the handbook(s) are shown as follows: 1) deleted language is indicated with a **bold face font using strikeouts** (e.g., ~~this report~~), 2) proposed new language is indicated with an **underscored bold faced font** (e.g., new items), and 3) nonretroactive items are identified in *italics*. There are instances where the Sector will use **red** text and/or **highlighted** text to bring emphasis to text that requires additional attention. When used in this report, the term “weight” means “mass.”

**Note:** It is the policy of the National Institute of Standards and Technology (NIST) to use metric units of measurement in all of its publications; however, recommendations received by NCWM technical committees and regional weights and measures associations have been printed in this publication as submitted. Therefore, the report may contain references in inch-pound units.

**Table A**  
**Table of Contents**

<b>Title of Content</b>	<b>NTEP Appendix Page E</b>
<b>INTRODUCTION</b> .....	<b>1</b>
<b>WELCOME/INTRODUCTIONS</b> .....	<b>3</b>
<b>CARRY-OVER ITEMS</b> .....	<b>3</b>
<b>1. Software Identification/Markings</b> .....	<b>3</b>
<b>2. Identification of Certified Software</b> .....	<b>14</b>
<b>3. Software Protection/Security</b> .....	<b>19</b>
<b>4. Software Maintenance and Reconfiguration</b> .....	<b>23</b>
<b>5. NTEP Application for Software and Software-based Devices</b> .....	<b>26</b>
<b>6. Training of Field Inspectors</b> .....	<b>28</b>
<b>NEW ITEMS</b> .....	<b>30</b>

<b>7. Next Meeting</b> .....	30
<b>8. 2014 NCWM Interim Meeting Report</b> .....	31
<b>9. 2013 International Report</b> .....	31

---

**Sub-Appendices**

**NTEP Page E /**

<b>A – List of Acceptable Menu Text/Icons for Weights/Measures Information</b> .....	<b>A1</b>
<b>B – Software Sector 2014 Goals (Presentation)</b> .....	<b>B1</b>
<b>C – 2014 Software Sector Meeting Attendees</b> .....	<b>C1</b>

---

**Table B**  
**Glossary of Acronyms and Terms**

---

<b>Acronym</b>	<b>Term</b>	<b>Acronym</b>	<b>Term</b>
BIML	International Bureau of Legal Metrology	OWM	Office of Weights and Measures
CC	Certificate of Conformance	PDC	Professional Development Committee
EPO	Examination Procedure Outline	PDC	Professional Development Committee
GMMs	Grain Moisture Meters	S&T	Specifications and Tolerances Committee
NCWM	National Conference on Weights and Measures	SMA	Scale Manufacturers Association
NTEP	National Type Evaluation Program	WELMEC	European Cooperation in Legal Metrology
OIML	International Organization of Legal Metrology		

---

**Details of All Items**  
*(In order by Reference Key)*

---

## **WELCOME/INTRODUCTIONS**

Since the first day of this year’s Sector meeting was a joint meeting with the Weighing Sector, there was some time set aside to meet and greet both new and familiar faces. In addition, the Software Sector gave a brief presentation outlining the problems they've been asked to consider and some of the consensus that has been reached.

## **STATUS REPORTS – RELATED NCWM AND INTERNATIONAL ACTIVITY**

Attendees of the 2014 NCWM Interim Meeting were asked to share any relevant comments or discussion that took place during the open hearings or NCWM Standards and Tolerances (S&T) Committee working sessions.

Dr. Ambler Thompson, NIST, Office of Weights and Measures (OWM), provided a synopsis of international activity that relates to the work of the sector.

## **JOINT SESSION PROGRESS REPORT, ACTIVE ITEMS OF MUTUAL INTEREST**

Since this is the first joint meeting of the Sectors, it is expected that some time will be required to review the agenda items of the Sectors that require collaboration, so all participants have a solid foundation for discussion. As part of this review, items of particular importance or interest should be allocated more time during the joint session day.

## **SOFTWARE SECTOR PRESENTATION**

Mr. Doug Bliss, Software Sector technical advisor, gave a short presentation on the current issues being addressed by the Software Sector (see Appendix B) to the joint group. The presentation was well received; and generated some discussion. Mr. Adam Oldham pointed out that WELMEC doesn’t go into minute detail regarding what is metrologically significant. He also asked how the manufacturer is intended to demonstrate the separation of software. Mr. Jim Pettinato responded that he thinks this will likely be a “paperwork demonstration,” and that eventually we’ll need to go into more detail on the subject. There was discussion of OIML’s requirements, and how they’re becoming less stringent over time.

Mr. Rainer Holmberg asked whether there have been problems with fraudulent software in the marketplace. Mr. Jim Truex said that instances have occurred in Los Angeles County, California, and Detroit, Michigan. There was also a problem with zero tracking that was found. Mr. Mike Wedman also related situations he’d encountered in the field that obviously did not provide sufficient protection of the software.

Mr. Truex attempted to explain the direction we’ve been going in – though we are looking to OIML/WELMEC, there is no intent to go to their extent of detail.

The checklist that has been in development for inclusion in NCWM Publication 14 by the Software Sector was brought up during this discussion (see Agenda Item 3); it was pointed out that the Weighing Sector has already agreed to put the checklist into NCWM Publication 14.

## **CARRY-OVER ITEMS**

### **1. Software Identification/Markings**

#### **Sources:**

- 2009 NTEP Software Sector agenda Item 3 and 2010 S&T Item 310-3, G-S.1 Identification (Software)

- 2010 Final Report of the S&T Committee:  
<https://ncwm.net/content/annual-archive> or  
<https://www.nist.gov/sites/default/files/documents/pml/wmd/pubs/2011/06/13/08-st-10-annual-final.pdf>
- 2010 Software Sector Summary:  
<https://www.ncwm.net/committees/ntep/sectors/software>
- 2011 Software Sector Summary:  
<https://www.ncwm.net/committees/ntep/sectors/software>.
- 2011 Final Report of the S&T Committee (NCWM Publication 16 and addendum sheets):  
<https://ncwm.net/content/annual-archive> or  
<https://www.nist.gov/sites/default/files/documents/pml/wmd/pubs/2011/12/13/08-st-11-annual-final.pdf>.
- 2012 Software Sector summary:  
<https://www.ncwm.net/committees/ntep/sectors/software/archive>
- 2012 Final Report of the S&T Committee:  
<https://www.nist.gov/sites/default/files/documents/pml/wmd/pubs/2013/07/09/08-st-12-annual-final.pdf>.
- 2013 Software Sector Summary:  
[http://www.ncwm.net/resources/dyn/files/981560z45f7a5f5/\\_fn/12\\_Software\\_Sector\\_Activity.pdf](http://www.ncwm.net/resources/dyn/files/981560z45f7a5f5/_fn/12_Software_Sector_Activity.pdf).
- 2013 Final Report of the S&T Committee:  
<https://www.nist.gov/sites/default/files/documents/pml/wmd/pubs/2013/12/27/08-st-13-annual-final.pdf>.
- 2014 Final Report of the S&T Committee:  
<https://www.nist.gov/sites/default/files/documents/2016/09/27/08-st-14-annual-final.pdf>.

**Background:**

Local weights and measures inspectors need a means to determine whether equipment discovered in the field has been evaluated by NTEP. If so, the inspector needs to know at a minimum the CC number. From this starting point, other required information can be ascertained (e.g., the software version or revision identifier of the software installed in an electronic device at the time it was evaluated). NIST Handbook 44 currently includes three options for marking of the CC:

1. permanent marking;
2. continuous display; and
3. Recall using a special operation.

Additional background information relative to this item can be found in *2014 NCWM Publication 16* at:  
[http://www.ncwm.net/resources/dyn/files/1217541z1019c056/\\_fn/4-ST-Pub16-2014-CORRECTED-06-12-2014.pdf](http://www.ncwm.net/resources/dyn/files/1217541z1019c056/_fn/4-ST-Pub16-2014-CORRECTED-06-12-2014.pdf).

During its 2013 meeting, the WS, at the request of the SS, reviewed and provided feedback on the following SS proposal to amend NIST Handbook 44 General Code Paragraphs G-S.1. Identification and G-S.1.1. Location of Marking Information for Not-Built-For-Purpose, Software-Based Devices:

***NIST Handbook 44 – Proposed Changes:***

**G-S.1. Identification.** – All equipment, except weights and separate parts necessary to the measurement process but not having any metrological effect, shall be clearly and permanently marked for the purposes of identification with the following information:

- (a) the name, initials, or trademark of the manufacturer or distributor;
- (b) a model identifier that positively identifies the pattern or design of the device;
  - (1) *The model identifier shall be prefaced by the word “Model,” “Type,” or “Pattern.” These terms may be followed by the word “Number” or an abbreviation of that word. The abbreviation for the word “Number” shall, as a minimum, begin with the letter “N” (e.g., No or No.). The abbreviation for the word “Model” shall be “Mod” or “Mod.” Prefix lettering may be initial capitals, all capitals, or all lowercase.*  
*[Nonretroactive as of January 1, 2003]*  
(Added 2000) (Amended 2001)
- (c) *a nonrepetitive serial number, except for equipment with no moving or electronic component parts and ~~not built for purpose software-based software devices~~ software;*  
*[Nonretroactive as of January 1, 1968]*  
(Amended 2003)
  - (1) *The serial number shall be prefaced by words, an abbreviation, or a symbol, that clearly identifies the number as the required serial number.*  
*[Nonretroactive as of January 1, 1986]*
  - (2) *for the word “Number” shall, as a minimum, begin with the letter “N” (e.g., S/N, SN, Ser. No., and S. No.).*  
*[Nonretroactive Abbreviations for the word “Serial” shall, as a minimum, begin with the letter “S,” and abbreviations s of January 1, 2001]*
- (d) *the current software version or revision identifier ~~for not built for purpose software-based electronic devices~~, which shall be directly linked to the software itself;*  
*[Nonretroactive as of January 1, 2004]*  
(Added 2003) (**Amended 20XX**)
  - (1) *The version or revision identifier shall be prefaced by words, an abbreviation, or a symbol, that clearly identifies the number as the required version or revision.*  
*[Nonretroactive as of January 1, 2007]*  
(Added 2006)
  - (2) *Abbreviations for the word “Version” shall, as a minimum, begin with the letter “V” and may be followed by the word “Number.” Abbreviations for the word “Revision” shall, as a minimum, begin with the letter “R” and may be followed by the word “Number.” The abbreviation for the word “Number” shall, as a minimum, begin with the letter “N” (e.g., No or No.).*  
*[Nonretroactive as of January 1, 2007]*  
(Added 2006)
  - (3) **The version or revision identifier shall be accessible via the display. Instructions for displaying the version or revision identifier shall be described in the CC. As an exception, permanently marking the version or revision identifier shall be acceptable under the following conditions:**
    - (a) **The user interface does not have any control capability to activate the indication of the version or revision identifier on the display, or the display does not technically allow the**

version or revision identifier to be shown (analog indicating device or electromechanical counter) or

**(b) the device does not have an interface to communicate the version or revision identifier.**

(e) an NTEP CC number or a corresponding CC Addendum Number for devices that have a CC.

- (1) *The CC Number or a corresponding CC Addendum Number shall be prefaced by the terms “NTEP CC,” “CC,” or “Approval.” These terms may be followed by the word “Number” or an abbreviation of that word. The abbreviation for the word “Number” shall, as a minimum, begin with the letter “N” (e.g., No or No.)*  
[Nonretroactive as of January 1, 2003]

The required information shall be so located that it is readily observable without the necessity of disassembly or a part requiring the use of many means separate from the device.

(Amended 1985, 1991, 1999, 2000, 201, 2003, ~~and 2006,~~ **and 201X**)

**G-S.1.1. Location of Marking Information for ~~Not-Built-For-Purpose~~ All Software-Based Devices. – For ~~not-built-for-purpose~~ software-based devices, either:**

(a) *The required information in G-S.1. Identification. (a), (b), ~~(d)~~, and (e) shall be permanently marked or continuously displayed on the device; or*

(b) *The CC Number shall be:*

(1) *permanently marked on the device;*

(2) *continuously displayed; or*

(3) *accessible through an easily recognized menu and, if necessary, a submenu. Examples of menu and submenu identification include, but are not limited to, “Help,” “System Identification,” “G-S.1. Identification,” or “Weights and Measures Identification.”*

**Note:** *For (b), clear instructions for accessing the information required in G-S.1. (a), (b), and (d) shall be listed on the CC, including information necessary to identify that the software in the device is the same type that was evaluated.*

[Nonretroactive as of January 1, 2004]

(Added 2003) (Amended 2006 **and 20XX**)

See the 2013 WS Final Report to view the feedback provided by the WS on the SS’s proposal to amend paragraphs G-S.1. and G-S.1.1. and for additional background information relating to this item.

This item was also a “Developing” item on the 2014 S&T Committee’s agenda and remains so on the 2015 S&T Committee’s agenda. During the 2014 NCWM Annual Meeting, NIST OWM provided the following comments concerning the SS’s proposal:

The following two concerns and suggestions were provided concerning the changes proposed to subparagraph G-S.1.(d):

1. Deleting the words “for not-built-for-purpose software-based electronic devices” creates the implication that all equipment manufactured as of January 1, 2004, except weights and separate parts necessary to the measurement process but not having any metrological effect, would be required to be permanently marked with a current software version or revision identifier. OWM questions whether or not it is the Software Sector’s intent to require a software version or revision identifier be marked on equipment that is not electronic. If not the intent, OWM suggests that the Sector consider adding text to better clarify

the type of equipment intended to be addressed by this proposed change and offers the following additional text for consideration:

- (d) the current software version or revision identifier **for software-based electronic devices**, which shall be directly linked to the software itself;
2. The proposed changes, if adopted, would require a current software version or revision identifier be marked on both built-for-purpose and not-built-for purpose software based equipment manufactured as of January 1, 2004. If it is the intent of the Sector to require that a current software version or revision identifier be marked on built-for-purpose software based equipment, then the Sector might consider proposing that such a requirement be non-retroactive or that it become enforceable at some future date considering the time and cost involved in updating equipment already in service.

The following additional feedback was provided by OWM concerning the Software Sector's proposed changes to paragraphs G-S.1. and G-S.1.1.:

- It is not clear what equipment would be affected by the proposed changes to G-S.1.(c). By proposing that the word "software" be added, is the exception intended to apply to the software itself or to equipment in which the software is installed?
- In the proposed additions to G-S.1.(d)(3)(a), it is not clear what is meant by the phrase "or the display does not technically allow the version or revision identifier to be shown." The examples "analog indicating device" and "electromechanical counter" do not provide enough information to lead one to conclude that the intent is to address such things as numeric-only displays. That is, numeric-only displays that don't have the capability of displaying abbreviations for "version" or "revision" as noted in earlier comments originating from the Sector.
- NIST, OWM recommends adding some examples to clarify the types of devices described in paragraph G-S.1.(d)(3)(b).
- NIST, OWM agrees with the Software Sector's assertion that it may be possible to eventually eliminate G-S.1.1. at some future date.

OWM noted that a joint meeting of the Software and Weighing Sectors is planned in August 2014 to consider the current proposal and to try and reach agreement on the changes necessary to paragraph G-S.1. NIST, OWM encouraged the two Sectors to consider its comments and feedback when considering any changes to the language currently proposed for G-S.1. The approach used in the past has been for the Sectors to review the proposal in separate meeting sessions; however, this has not resulted in a proposal amenable to all Sectors. OWM believes that it might be more expedient for all of the Sectors to collaborate in a single joint meeting to try and reach agreement on the changes needed.

Following the 2014 NCWM Annual Meeting, members of NST, OWM's Legal Metrology Devices Program (LMDP) were requested to provide additional input on the proposal to modify G-S.1. and G.S.1.1. in consideration of the goals of the SS and the comments provided during the 2014 Open Hearings of the S&T Committee relating to this item.

The following is a list of the goals provided by the SS in modifying G-S.1. and G.S.1.1. as communicated to the members of NIST, OWM's LMDP:

1. Remove the existing distinction between software identification requirements for built-for-purpose and not-built-for-purpose devices.
2. To require that all software-based devices have a software version or revision identifier for metrologically significant software.



3. Require that certified software versions or revision identifiers for metrologically significant software is recorded on the CC for access by inspectors.
4. Software itself does not require serial numbers.
5. Require that software-based devices version or revision identifier shall be accessible via the display and user interface and only if device's display is incapable of displaying the identifier or has no display and/or interface; then permanently marking the version or revision identifier shall be acceptable (e.g., digital load cell).
6. Nonretroactive as of January 1, 2016, if passed by the NCWM in July 2015.

NIST, OWM's LMDP developed the following proposed draft alternative changes to G-S.1. based on the SS's request for additional input on how best to meet its goals and forwarded them to the Chairman of the SS for consideration at the 2014 WS/SS joint meeting:

Amend NIST Handbook 44: G-S.1. Identification and G-S.1.1. Location of Marking Information for Not-Built-For- Purpose, Software-Based Devices as follows:

**G-S.1. Identification.** – All equipment, except weights and separate parts necessary to the measurement process but not having any metrological effect, shall be clearly and permanently marked for the purposes of identification with the following information:

- (a) the name, initials, or trademark of the manufacturer or distributor;
- (b) a model identifier that positively identifies the pattern or design of the device;
  - (1) *The model identifier shall be prefaced by the word "Model," "Type," or "Pattern." These terms may be followed by the word "Number" or an abbreviation of that word. The abbreviation for the word "Number" shall, as a minimum, begin with the letter "N" (e.g., No or No.). The abbreviation for the word "Model" shall be "Mod" or "Mod." Prefix lettering may be initial capitals, all capitals, or all lowercase.*  
[Nonretroactive as of January 1, 2003]  
(Added 2000) (Amended 2001)
- (c) *a nonrepetitive serial number, except for equipment with no moving or electronic component parts and ~~not built for purpose software-based devices software;~~*  
[Nonretroactive as of January 1, 1968]  
(Amended 2003)
  - (1) *The serial number shall be prefaced by words, an abbreviation, or a symbol, that clearly identifies the number as the required serial number.*  
[Nonretroactive as of January 1, 1986]
  - (2) *Abbreviations for the word "Serial" shall, as a minimum, begin with the letter "S," and abbreviations for the word "Number" shall, as a minimum, begin with the letter "N" (e.g., S/N, SN, Ser. No., and S. No.).*  
[Nonretroactive as of January 1, 2001]

- (d) the current software version or revision identifier for not-built-for-purpose software-based devices; **manufactured as of January 1, 2004, through December 31, 2015, and all software based devices or equipment manufactured as of January 1, 2016;**

~~[Nonretroactive as of January 1, 2004]~~

(Added 2003) **(Amended 20XX)**

(1) *The version or revision identifier shall be:*

- i. *prefaced by words, an abbreviation, or a symbol, that clearly identifies the number as the required version or revision;*

~~[Nonretroactive as of January 1, 2007]~~

(Added 2006)

- ii. **directly linked to the software itself; and**

~~[Nonretroactive as of January 1, 2016]~~

**(Added 20XX)**

- iii. **continuously displayed\* or be accessible via the display menus. Instructions for displaying the version or revision identifier shall be described in the CC. As an exception, permanently marking the version or revision identifier shall be acceptable providing the device does not have an integral interface to communicate the version or revision identifier.**

~~[Nonretroactive as of January 1, 2016]~~

**(Added 20XX)**

**\*The version or revision identifier shall be displayed continuously on software equipment with a digital display manufactured as of January 20XX and all software-based equipment with a digital display as of January 1, 20XX.**

- (2) *Abbreviations for the word “Version” shall, as a minimum, begin with the letter “V” and may be followed by the word “Number.” Abbreviations for the word “Revision” shall, as a minimum, begin with the letter “R” and may be followed by the word “Number.” The abbreviation for the word “Number” shall, as a minimum, begin with the letter “N” (e.g., No or No.).*

~~[Nonretroactive as of January 1, 2007]~~

(Added 2006)

- (e) *an National Type Evaluation Program (NTEP) Certificate of Conformance (CC) number or a corresponding CC Addendum Number for devices that have a CC.*

- (1) *The CC Number or a corresponding CC Addendum Number shall be prefaced by the terms “NTEP CC,” “CC,” or “Approval.” These terms may be followed by the word “Number” or an abbreviation of that word. The abbreviation for the word “Number” shall, as a minimum, begin with the letter “N” (e.g., No or No.)*

~~[Nonretroactive as of January 1, 2003]~~

The required information shall be so located that it is readily observable without the necessity of the disassembly of a part requiring the use of any means separate from the device.

(Amended 1985, 1991, 1999, 2000, 2001, 2003, ~~and~~, 2006 **and 201X**)

**G-S.1.1. Location of Marking Information for ~~Not-Built-For-Purpose~~ All Software-Based Devices.** – For ~~not built for purpose~~, software-based devices, either:

(a) *The required information in G-S.1. Identification. (a), (b), ~~(d)~~, and (e) shall be permanently marked or continuously displayed on the device; or*

(b) *The CC Number shall be:*

(1) *permanently marked on the device;*

(2) *continuously displayed; or*

(3) *accessible through an easily recognized menu and, if necessary, a submenu. Examples of menu and submenu identification include, but are not limited to, “Help,” “System Identification,” “G-S.1. Identification,” or “Weights and Measures Identification.”*

**Note:** *For (b), clear instructions for accessing the information required in G-S.1. (a), (b), and (d) shall be listed on the CC, including information necessary to identify that the software in the device is the same type that was evaluated.*

*[Nonretroactive as of January 1, 2004]*

*(Added 2003) (Amended 2006 **and 20XX**)*

No changes to subparagraph G-S.1.1. were proposed by OWM’s LMDP since the SS had indicated earlier that it may be possible to eventually eliminate G-S.1.1. Thus, the proposed changes to subparagraph G-S.1.1. shown above in OWM’s draft alternative changes are those originating from the SS’s 2013 proposal.

In providing feedback to the SS, OWM’s LMDP noted that the shaded portion of G-S.1.(d)(1).iii of their draft alternative changes was developed solely by OWM (i.e., does not reflect any of the goals communicated by the SS) and was being offered for consideration with the understanding that:

1. this change will make it easier in the future for inspectors to be able to identify software installed in equipment;
2. a reasonable amount of time for the changes to take effect can be specified; and
3. it is probable that improvements in technology over time will make it easier for equipment manufacturers to comply.

In addition to the alternative changes proposed by NIST, OWM’s LMDP, a member of the SS submitted the following definition of “software-based devices” for discussion during the joint meeting of the WS and SS and possible future inclusion into Appendix D of NIST Handbook 44:

**software-based devices:** devices used to compute and control processes using software, where software is a general term for the programs and data used to operate the computers and/or related electronic devices. Software-based device may also consist of just software (e.g., weigh in/weigh out software).

#### **Discussion/Conclusion:**

During the joint meeting of the WS and SS, the Chairman of the SS led a discussion on the identification of software; more specifically, the changes that have been proposed or that are needed to G-S.1. and G S.1.1. and the reasons why these changes are important. He reviewed the SS’s 2013 draft proposal to amend G-S.1. and G-S.1.1., and the comments that had been received since its distribution. Very few constructive comments had been received except for some provided by NIST, OWM, which the Chairman reviewed one by one; requesting additional clarification from the NIST Technical advisor as needed.

Once the review of the Sector’s draft proposal had been completed, it was then pointed out that NIST OWM’s LMDG had developed some suggested alternative changes to the SS’s proposal at the request of the SS. Members of both

sectors were asked to review and consider the alternative changes proposed by OWM's LMDP, which were provided in a handout to members of both sectors and displayed on screen.

The NIST Technical Advisor to the WS, also a member of OWM's LMDP, explained the reasons for NIST, OWM's proposed alternative changes to *G-S.1. Identification*. Initial discussions of the group regarding OWM's draft changes mostly concentrated on three main issues/concerns as follows:

1. Why is it necessary to retain the term “not-built-for-purpose software-based devices” and add enforcement dates to G-S.1.(d) when it is the Sector's intention to treat built-for-purpose and not-built-for-purpose devices the same with respect to identifying software?
2. Consideration of the text that OWM had developed and was proposing for addition to G-S.1.(d) iii.
3. What would be the effective dates of any changes agreed upon by the group?

The following is a brief summary of the discussions and actions taken by the two sectors relative to these three issues/concerns:

1. With regard to the changes proposed to G-S.1.(d), the NIST Technical Advisor to the WS indicated that it was OWM's view that a separation between built-for purpose and not-built-for-purpose software-based devices needed to be maintained within the paragraph because the current requirement (i.e., G-S.1.(d)) only applies to not-built-for-purpose software-based devices. Although the SS's intention is to expand the requirement to apply to all electronic devices, it would not be appropriate to require existing built-for-purpose-equipment, which is already in service, to comply with the proposed changes to G-S.1. since this equipment has not had to do so previously. Updating existing equipment, in order to make it comply with new requirements, could be costly to both manufacturers and device owners. Additionally, it may not be possible for some built-for-purpose devices to provide an indication of the current software version or revision identifier. Although marking of the version or revision identifier using a label affixed to the device might be an option, how would officials be able to tell if the version of software installed in the device actually matched the marking on the device? By adding effective dates, as proposed, the separation can be maintained and still provide a means of requiring all new electronic equipment to comply. The NIST Technical Advisor also acknowledged that it may be possible at some future date to remove the reference to “not built for-purpose” in the paragraph. Members of the two Sectors agreed, although it was decided that the words “through December 31, 2015,” in the lead-in sentence of G-S.1.(d) should be deleted because the inclusion of this date is not necessary and its removal does not in any way change the proposal.
2. There were significant concerns raised by equipment manufacturers regarding OWM's suggested proposal to require the continuous display of the version or revision identifier on software-based equipment having a digital display. It was stated that some displays; specifically referenced were “seven-segment digital displays of simple design,” do not have the capability of complying with the proposed note that had been developed by OWM. It was also stated that customer demand for these simple displays remains steady among the different scale manufacturers because of their low cost in relation to other digital displays that incorporate more current and complex technology. That is, some customers aren't willing to pay the extra money for a more complex display that can be made to comply with OWM's proposed note, such as one of the graphic types, when all that's needed is a simple basic display. Manufacturers did not see this situation changing and stated that sales of these displays are driven by their low cost. Another concern was the valuable “real estate” that the version or revision identifier would take up if it were continuously displayed.
3. In consideration of the fact that the proposed changes, if adopted, would require both built-for-purpose and not-built-for-purpose software-based equipment to continuously display the current software version or revision identifier, or that this information be accessible via the display menus, members of the two Sectors felt that the 2016 effective date proposed by OWM did not provide enough lead-in time for equipment manufacturers. Thus, the Sectors agreed to extend the date to 2020 by amending OWM's proposal to reflect this new date.

A fourth issue/concern, which was raised by an equipment manufacturer somewhat later in the discussions, is that some built-for-purpose equipment have limited capability of displaying letters of the alphabet, and, therefore, unable to comply with the prefacing requirements specified in G-S.1.(d)(1) and G-S.1.(d)(2). The example provided was a seven-segment display. It is not able to display a “V” or an “R,” which are the current acceptable abbreviations for “version” and “revision,” respectively. A “U” could be considered a symbol; however, it is not currently a symbol included in the list of acceptable abbreviations found in some NCWM Publication 14 device checklists. Alternatively, a lowercase “r” could be displayed on such an indicator. In consideration of this concern, it was suggested that a “note” be added to G-S.1.(d) permitting the NTEP evaluators to specify a different method of indication if the device is incapable of prefacing the software version/revision with a “V” or “R.” The Sectors agreed to propose a “note” be added and let the S&T Committee decide whether the “note” is necessary or appropriate. An additional change agreed upon by the Sectors relating to this issue/concern was to add the last sentence of G-S.1.(b) to the end of G-S.1.(d)(2). In discussing this issue/concern, it was also stated that some built-for-purpose devices only indicate the software version or revision identification during power up. That is, in order to view the software identification, it is necessary to shut off and then return power to the device. It was noted that some officials have been instructed not to power down equipment they are inspecting for liability reasons. There were no solutions to this (power down/power up) concern offered by members of either Sector.

Although the SS had earlier proposed changes to G-S.1.1., it was decided during the meeting that no changes to GS.1.1. were necessary since the Sectors had agreed to retain the term “not-built-for-purpose software-based devices” in G-S.1.(d). Thus, no changes are proposed to paragraph G-S.1.1. The following reflects all of the changes to paragraph G-S.1. that were agreed upon by the two Sectors during the joint meeting:

**Amend NIST Handbook 44: G-S.1. Identification as follows:**

**G-S.1. Identification.** – All equipment, except weights and separate parts necessary to the measurement process but not having any metrological effect, shall be clearly and permanently marked for the purposes of identification with the following information:

- (a) the name, initials, or trademark of the manufacturer or distributor;
- (b) a model identifier that positively identifies the pattern or design of the device;
  - (1) *The model identifier shall be prefaced by the word “Model,” “Type,” or “Pattern.” These terms may be followed by the word “Number” or an abbreviation of that word. The abbreviation for the word “Number” shall, as a minimum, begin with the letter “N” (e.g., No or No.). The abbreviation for the word “Model” shall be “Mod” or “Mod.” Prefix lettering may be initial capitals, all capitals, or all lowercase.*  
[Nonretroactive as of January 1, 2003]  
(Added 2000) (Amended 2001)
- (c) *a nonrepetitive serial number, except for equipment with no moving or electronic component parts and ~~not built for purpose software based software devices~~ software;*  
[Nonretroactive as of January 1, 1968]  
(Amended 2003)
  - (1) *The serial number shall be prefaced by words, an abbreviation, or a symbol, that clearly identifies the number as the required serial number.*  
[Nonretroactive as of January 1, 1986]
  - (2) *Abbreviations for the word “Serial” shall, as a minimum, begin with the letter “S,” and abbreviations for the word “Number” shall, as a minimum, begin with the letter “N” (e.g., S/N, SN, Ser. No., and S. No.).*  
[Nonretroactive as of January 1, 2001]

- (d) the current software version or revision identifier for not-built-for-purpose software-based devices; **manufactured as of January 1, 2004, and all software-based devices or equipment manufactured as of January 1, 2020;**

**[Nonretroactive as of January 1, 2004]**

(Added 2003) **(Amended 20XX)**

(1) *The version or revision identifier shall be:*

- i. *prefaced by words, an abbreviation, or a symbol, that clearly identifies the number as the required version or revision;*

*[Nonretroactive as of January 1, 2007]*

(Added 2006)

**Note: If the equipment is capable of displaying the version or revision identifier but is unable to meet the formatting requirement, through the NTEP type evaluation process, other options may be deemed acceptable and described in the CC.**

**(Added 20XX)**

- ii. **directly linked to the software itself; and**

**[Nonretroactive as of January 1, 2020]**

**(Added 20XX)**

- iii. **continuously displayed or be accessible via the display. Instructions for displaying the version or revision identifier shall be described in the CC. As an exception, permanently marking the version or revision identifier shall be acceptable providing the device does not have an integral interface to communicate the version or revision identifier.**

**[Nonretroactive as of January 1, 2020]**

**(Added 20XX)**

- (2) *Abbreviations for the word “Version” shall, as a minimum, begin with the letter “V” and may be followed by the word “Number.” Abbreviations for the word “Revision” shall, as a minimum, begin with the letter “R” and may be followed by the word “Number.” The abbreviation for the word “Number” shall, as a minimum, begin with the letter “N” (e.g., No or No.). **Prefix lettering may be initial capitals, or all lowercase.***

*[Nonretroactive as of January 1, 2007]*

(Added 2006)

- (e) *a National Type Evaluation Program (NTEP) Certificate of Conformance (CC) number or a corresponding CC Addendum Number for devices that have a CC.*

- (1) *The CC Number or a corresponding CC Addendum Number shall be prefaced by the terms “NTEP CC,” “CC,” or “Approval.” These terms may be followed by the word “Number” or an abbreviation of that word. The abbreviation for the word “Number” shall, as a minimum, begin with the letter “N” (e.g., No or No.)*

*[Nonretroactive as of January 1, 2003]*

The required information shall be so located that it is readily observable without the necessity of the disassembly of a part requiring the use of any means separate from the device.

(Amended 1985, 1991, 1999, 2000, 2001, 2003, ~~and~~, 2006 **and 201X)**

An additional issue that was discussed during the joint meeting is whether or not the updating of metrological software should be considered a sealable event or sealable parameter. It was agreed that an update to metrological

software is a sealable event and needs to be protected using an approved means of security. The Sectors then considered whether it would be appropriate to include the updating of metrological software in the list of sealable parameters in NCWM Publication 14 or to provide for its security by proposing a new General Code requirement be added to NIST Handbook 44. The Sectors decided that the updating of metrological software can affect multiple sealable parameters, and, therefore, it is appropriate to address its security in the General Code of NIST Handbook 44. Consequently, the Sectors decided to complete and submit an NCWM Form 15 proposing there be a new General Code requirement added to the handbook to address the security of software updates.

The two Sectors agreed that much progress had been made during the joint meeting, but that paragraph G-S.1., as revised during the meeting, is not likely to be considered for Vote by the NCWM. In consideration of the progress that was made, the Sectors agreed to recommend that the “Developing” status of the item be changed to “Informational” and forward the revised draft of G-S.1. to the different regional associations for their consideration at their next meeting.

Based on the feedback received by the S&T Committee regarding agenda Item 1, we are of the opinion that it may no longer be possible to avoid providing a definition for “software-based electronic devices.” A discussion on possible definitions commenced. Members of the two Sectors reviewed a draft definition of “software-based devices” that had been developed by a member of the Sector in consideration of a comment that had been received by the S&T Committee during one of the 2014 NCWM Conferences. The Sectors decided that a simpler definition may be more palatable, that is:

*Software Based Device – Any device with metrologically significant software.*

If they feel it is imperative to have a definition for this term (which many in the Sector feel is self-defining), the S&T Committee can point us in the direction of one or the other of the proposed definitions.

## 2. Identification of Certified Software

### Source:

NTEP Software Sector

### Background/Discussion:

This item originated as an attempt to answer the question, “How does the field inspector know that the software running in the device is the same software evaluated and approved by the lab?” In previous meetings, it was shown that the international community has addressed this issue (both WELMEC and OIML).

*From WELMEC 7.2:*

#### Required Documentation:

The documentation shall list the software identifications and describe how the software identification is created, how it is inextricably linked to the software itself, how it may be accessed for viewing, and how it is structured in order to differentiate between version changes with and without requiring a type approval.

*From OIML D-31:*

The executable file “**tt100\_12.exe**” is protected against modification by a checksum. The value of checksum as determined by algorithm **XYZ** is **1A2B3C**.

Previous discussions have included a listing of some additional examples of possible valid methods (not limiting):

- CRC (cyclical redundancy check)
- Checksum

- Inextricably Linked version no.
- Encryption
- Digital Signature

**Is there some method to give the weights and measures inspector information that something has changed?**

Yes, the Category III Audit Trail or other means of sealing.

**How can the weights and measures inspector identify an NTEP Certified version?**

They can't, without adding additional requirements like what is described here, in conjunction with including the identifier on the CC).

The Sector believes that we should work towards language that would include a requirement similar to the International Organization of Legal Metrology (OIML) requirement in NIST Handbook 44. It is also the opinion of the Sector that a specific method should not be defined; rather the manufacturer should utilize a method and demonstrate the selected identification mechanism is suitable for the purpose. It is not clear from the discussion where such proposed language might belong.

NTEP strongly recommends that metrological software be separated from non-metrological software for ease of identification and evaluation.

*From OIML:*

**Separation of software parts.** – All software modules (programmes, subroutines, objects etc.) that perform metrologically significant functions or that contain metrologically significant data domains form the metrologically significant software part of a measuring instrument (device or sub-assembly). The conformity requirement applies to all parts and parts shall be marked according to Section G-S-X.X.

If the separation of the software is not possible or needed, then the software is metrologically significant as a whole.

(Segregation of parameters is currently allowed - see table of sealable parameters)

*Initial draft proposed language: (G-S.1.1?)*

NIST Handbook 44 (This has been written into G-S.1.(d)(3): Identification of Certified Software):

**Software-based electronic devices shall be designed such that the metrologically significant software is clearly identified by the version or revision number. The identification, and this identification of the software shall be inextricably directly and inseparably linked to the software itself. The version or revision number may consist of more than one part, but at least one part shall be dedicated to the metrologically significant software.**

*From NCWM Publication 14:*

Identification of Certified Software:

**Note:** Manufacturers may choose to separate metrologically significant software from non-metrologically significant software. Separation would allow the revision of the non-metrological portion without the need for further evaluation. In addition, non-metrologically significant software may be updated on devices without breaking a seal, if so designed. Separation of software requires that all software modules (programs, subroutines, objects etc.) that perform metrologically significant functions or that contain metrologically significant data **domains** form the metrologically significant software part of a measuring instrument (device or sub-assembly). If the separation of the software is not possible or needed, then the software is metrologically significant as a



whole. ~~The conformity requirement applies to all parts and parts shall be marked according to Section G-S.X.X.~~

The manufacturer must describe and possibly demonstrate how the version or revision identifier is directly and inseparably linked to the metrologically significant software. Where the version revision identifier is comprised of more than one part, the manufacturer shall describe which portion represents the metrological significant software and which does not.

*From OIML D-31:*

Legally relevant software of a measuring instrument/electronic device/sub-assembly shall be clearly identified with the software version or another token. The identification may consist of more than one part but at least one part shall be dedicated to the legal purpose.

The identification shall be inextricably linked to the software itself and shall be presented or printed on command or displayed during operation or at start up for a measuring instrument that can be turned off and on again. If a sub-assembly/an electronic device has neither display nor printer, the identification shall be sent via a communication interface in order to be displayed/printed on another sub-assembly/electronic device.

The first sentence of the first paragraph above is already addressed in NIST Handbook 44's marking requirements.

In 2010, the Sector recommended the following change to NIST Handbook 44, General Code: G-S.1.(d) to add a new subsection (3):

(d) *the current software version or revision identifier for ~~not built for purpose~~ software-based electronic devices;*

*[Nonretroactive as of January 1, 2004]*

(Added 2003) **(Amended 20XX)**

(1) *The version or revision identifier shall be prefaced by words, an abbreviation, or a symbol, that clearly identifies the number as the required version or revision.*

*[Nonretroactive as of January 1, 2007]*

(Added 2006)

(2) *Abbreviations for the word "Version" shall, as a minimum, begin with the letter "V" and may be followed by the word "Number." Abbreviations for the word "Revision" shall, as a minimum, begin with the letter "R" and may be followed by the word "Number." The abbreviation for the word "Number" shall, as a minimum, begin with the letter "N" (e.g., No or No.).*

*[Nonretroactive as of January 1, 2007]*

(Added 2006)

**(3) The version or revision identifier shall be directly and inseparably linked to the software itself. The version or revision identifier may consist of more than one part, but at least one part shall be dedicated to the metrologically significant software.**

*[Nonretroactive as of January 1, 20XX]*

**(Added 20XX)**

Also the Sector recommends the following information be added to NCWM Publication 14 as explanation/examples:

- Unique identifier must be displayable/printable on command or during operation, etc.
- At a minimum, a version/revision indication (1.02.09, rev 3.0 a, etc.). Could also consist of/contain checksum, etc. (crc32, for example).

There was some additional discussion on this item regarding where this new requirement was best located. It was suggested that the first sentence of G-S.1.(d)(3) could be added as a clause to the base paragraph GS.1.(d) text (e.g., “*the current software version or revision identifier for ~~not-built-for-purpose-software-based~~ devices, which shall be directly and inseparably linked to the software itself*”).

It also was suggested that the second sentence in G-S.1.(d)(3) might be more suitable for NCWM Publication 14, as it describes more “how” than “what” the requirement entails.

In addition, the Sector considered the following information to be added to NCWM Publication 14 as explanation/examples:

- The current software identifier must be displayable/printable on command during operation (or made evident by other means deemed acceptable by G-S.1.).
- At a minimum, the software identifier must include a version/revision indication (1.02.09, rev 3.0 a, etc.). It could also consist of/contain checksum, etc. (crc32, for example).
- The version or revision identifier may consist of more than one part, but at least one part shall be dedicated to the metrologically significant software.

Other questions that are still outstanding:

- If we allow hard-marking of the software identifier (the Sector has wavered on this in the past), does the above wording then imply that some mechanical means is required (i.e., physical seal) to “inseparably link” the identifier to the software?
- If a device is capable of doing so, does it still have to be able to display, print or communicate the identifier somehow, even if it is hard-marked?

At the 2012 NTEP Software Sector Meeting, there was some discussion as to where the terminology regarding inextricably linking the software version or revision to the software itself belonged. At the moment, it is not incorporated in the proposed text for G-S.1. NCWM Publication 14 may be a better option for the time being. This would be another item that would benefit from further explanation in a supplementary document.

One suggestion was this revision to G-S.1.(d):

- (d) ~~when metrologically significant software is employed,~~ the current software version or revision identifier, which shall be directly and inseparably linked to the software itself; ~~for not-built-for-purpose software-based electronic devices;~~

Alternatively, if the previously proposed new subsection G-S.1.(d)(3) from Item 1 is adopted, this concept could be inserted thus:

- (3) *The version or revision identifier shall be directly and inseparably linked to the software itself and accessible via the display. Instructions for displaying the version or revision identifier shall be described in the CC. As an exception, permanently marking the version or revision identifier shall be acceptable under the following conditions:*

Several Sector members were of the opinion that attempting to make this change at the same time as the earlier changes might be a difficult sell. Mr. Truex, NTEP Administrator, reiterated the necessity of baby steps.

The Sector recommended adding the following to NCWM Publication 14 and forward to NTEP Weighing, Measuring, and Grain Analyzer Sectors for feedback:

Identification of Certified Software:

**Note:** Manufacturers may choose to separate metrologically significant software from non-metrologically significant software. Separation would allow the revision of the non-metrological portion without the need for further evaluation. In addition, non-metrologically significant software may be updated on devices without breaking a seal, if so designed. Separation of software requires that all software modules (programs, subroutines, objects etc.) that perform metrologically significant functions or that contain metrologically significant data domains form the metrologically significant software part of a measuring instrument (device or sub-assembly). If the separation of the software is not possible or needed, then the software is metrologically significant as a whole. The conformity requirement applies to all parts and parts shall be marked according to Section G-S.X.X.

The manufacturer must describe and possibly demonstrate how the version or revision identifier is directly and inseparably linked to the metrologically significant software. Where the version revision identifier is comprised of more than one part, the manufacturer shall describe which portion represents the metrological significant software and which does not.

Also, it was decided to forward the two alternate options for adding requirements for uniquely identifying software to the individual sectors:

One suggestion was this revision to G-S.1.(d):

- (d) ~~when metrologically significant software is employed, the current software version or revision identifier, which shall be directly and inseparably linked to the software itself; for not built for purpose software based electronic devices;~~

Alternatively, if the previously proposed new subsection G-S.1.(d)(3) from Item 1 is adopted, this concept could be inserted thus:

- (3) The version or revision identifier shall be directly and inseparably linked to the software itself and accessible via the display. Instructions for displaying the version or revision identifier shall be described in the CC. As an exception, permanently marking the version or revision identifier shall be acceptable under the following conditions:**

The Measuring Sector reviewed this item and had no feedback other than a statement that they support the continuing/ongoing efforts of this sector. The Weighing Sector summary mentioned that no one opted to provide comment. They agreed to take no further action on this item, pending further action from the Software Sector. This was specifically in reference to the accepted symbols.

For the time being, Mr. Jim Truex recommended that we not attempt to provide a definition for “software-based device.” We discussed the possibility of combining this change with the first agenda item, which had been attempted in previous years. Alternatively, if the NIST Handbook 44 changes from agenda Item 1 are made, this agenda item could be addressed in NCWM Publication 14.

After further discussion, the proposed wording in G-S.1.d under agenda item 1 was changed. Agenda Item 2 will remain; however, it will address potential changes to NCWM Publication 14 and contain no suggested modifications to NIST Handbook 44. (See changes and conclusion under agenda item 1 for further details.)

The Sector chair volunteered to review the existing slide presentation detailing the purpose of these changes, to ensure that it accurately reflects this information. This was done by the Technical Advisor and the most recent version reflects our current point of consensus (see Appendix B).

The list of acceptable menu text and symbols in Appendix A are intended to assist the labs in finding the certification number. The Sector noticed no action by the sectors had been taken when this list was circulated for comment. We would like to remind them that we would like to have it reviewed. We feel that this belongs in, for example, the Weighing Device NCWM Publication 14, page DES-22, Section 3; the Belt- Conveyor Scales, page BCS-10,

Section 8.7; the Measuring Devices, page LMD-21, Section 1.6; the Grain Moisture Meter, page GMM-14, Section 1 (G.S.1); and Near Infrared Grain Analyzers, page NIR-8, Section 1 (G.S.1).

**Conclusion:**

Some of the Sectors (Weighing, Measuring) have already agreed to put the two paragraphs of text appearing at the top of page NTEP-3 in NCWM Publication 14. (The sentence that has been struck out in the first paragraph was not included because NIST Handbook 44 hasn't been altered to make it a requirement.)

This agenda item will likely require less time during future meetings as it seems to be nearly finalized. Outstanding work remaining is to secure buy-in from the remaining Sectors that have yet to adopt this recommendation to include in NCWM Publication 14. Once those Sectors reach a decision, this item can be considered complete and removed from future agendas.

### 3. Software Protection/Security

**Source:**

NTEP Software Sector

**Background:**

The Sector agreed that NIST Handbook 44 already has audit trail and physical seal, but these may need to be enhanced.

*From the WELMEC Document:*

**Protection against accidental or unintentional changes:**

Metrologically significant software and measurement data shall be protected against accidental or unintentional changes.

**Specifying Notes:**

Possible reasons for accidental changes and faults are: unpredictable physical influences, effects caused by user functions and residual defects of the software even though state of the art of development techniques have been applied.

This requirement includes consideration of:

- a) Physical influences: Stored measurement data shall be protected against corruption or deletion when a fault occurs or, alternatively, the fault shall be detectable.
- b) User functions: Confirmation shall be demanded before deleting or changing data.
- c) Software defects: Appropriate measures shall be taken to protect data from unintentional changes that could occur through incorrect program design or programming errors, (e.g., plausibility checks).

**Required Documentation:**

The documentation should show the measures that have been taken to protect the software and data against unintentional changes.

**Example of an Acceptable Solution:**

- The accidental modification of software and measurement data may be checked by calculating a checksum over the relevant parts, comparing it with the nominal value and stopping if anything has been modified.
- Measurement data are not deleted without prior authorization (e.g., a dialogue statement or window asking for confirmation of deletion).
- For fault detection see also Extension I.

The Sector continued to develop a proposed checklist for NCWM Publication 14. The numbering will still need to be added. This is based roughly on R 76-2 checklist and discussions beginning as early as the October 2007 NTEP Software Sector Meeting. The information requested by this checklist is currently voluntary; however, it is recommended that applicants comply with these requests or provide specific information as to why they may not be able to comply. Based on this information, the checklist may be amended to better fit with NTEP's need for information and the applicant's ability to comply.

The California, Maryland, and Ohio laboratories agreed to use this checklist on one of the next devices they have in the lab and report back to the Sector on what the problems may be. In February 2011, the North Carolina laboratory was also given a copy of the check list to try.

The Maryland laboratory had particular questions regarding 3.1 and 5.1. The information for 3.1 could be acquired from an operator's manual, a training video, or in-person training. The items in 5.1 were confusing to the evaluators. The terminology is familiar to software developers, but not necessarily others. It was indicated that manufacturers were typically quick to return the filled out questionnaire, but he didn't know how his laboratory was supposed to verify that it was true. Generally, the laboratories wouldn't be expected to verify things to that level. For example, if the manufacturer states that a checksum is used to ensure integrity, the laboratories wouldn't be expected to evaluate the algorithm used.

The intent was to see whether the manufacturer had at least considered these issues, not for evaluators to become software engineers. Perhaps a glossary or descriptive paragraphs might be added to assist the evaluators for if the manufacturer has questions for the evaluators.

OIML makes use of supplementary documents to explain the checklist they use. Below are links:

<http://www.oiml.org/publications/D/D031-e08.pdf>

<http://www.welmec.org/latest/guides/72.html>

[http://www.welmec.org/fileadmin/user\\_files/publications/2-3.pdf](http://www.welmec.org/fileadmin/user_files/publications/2-3.pdf)

WELMEC document 2.3 is the original source for our checklist, but it's been significantly revised and simplified. Mr. Payne, Maryland Department of Agriculture, is going to review the other documents and come up with some suggestions for the checklist. Mr. Roach, California Division of Measurement Standards, is going to begin using the checklist. The international viewpoint is that any device running an operating system is considered to be Type U. Mr. Roach mentioned that they're having lots of problems with "skimmers" stealing PIN's. Is there some way they can detect this?

Mr. Lewis, Rice Lake Weighing Systems, Inc., mentioned that he liked Measurement Canada's website. When answering similar questions, different pages would appear, based on answers to those questions:  
<http://www.ic.gc.ca/eic/site/mc-mc.nsf/eng/lm00573.html>.

At the 2011 NTEP Software Sector Meeting, the laboratories were polled to obtain any feedback on the use of the checklist. Maryland attempted to use this checklist a few times. They had some difficulty obtaining answers from the manufacturers because the individual(s) interacting with the Maryland evaluator didn't always have the required information on hand. More experience in using the checklist will help determine what needs to be revised.

It was suggested that the checklist could be sent to manufacturers for their feedback as well, with the stipulation that it a completely voluntary exercise and purely informational at this point. The laboratories will coordinate with willing manufacturers to obtain feedback.

At the 2013 meeting, it was reported by the labs that attempts to use the current checklist did not meet with many difficulties. The checklists were given to the manufacturers to fill out, and that seemed to work rather well. Minor modifications were made to clarify certain confusing areas or eliminate redundancy. (**Note:** The text above includes the updates made in 2013).

**Discussion:**

The labs using this checklist on a trial basis indicated that there was some confusion as to versions/wording. There may be more than one version in circulation. The version shown in this Summary shall be used henceforth.

During the discussion, Mr. Ed Payne (NTEP lab, Maryland) said that his impression is that this is at least making some of the manufacturers think about security, which they hadn't necessarily done in the past.

It was indicated that some more or better examples may be helpful to manufacturers, and that more guidance is needed. Clearer instructions could be part of the checklist, or it could be a separate document. The Sector would like additional feedback specifically regarding what portions of it are causing confusion.

Due to proprietary issues, the labs can't simply give us direct feedback from the companies with which they interact. Mr. Darrell Flocken volunteered to obtain information from the labs, aggregate it, and remove any potential proprietary information issues.

The checklist as updated during the 2014 meeting:

**1. Devices with Software**

- 1.1. Declaration of the manufacturer that the software is used in a fixed hardware and software environment. **The manufacturer should indicate whether it's solely software or includes hardware in the system. Can the software be changed after the system has been shipped without breaking a seal? AND**  Yes  No  N/A

- 1.2. Cannot be modified or uploaded by any means after securing/verification. **With the seal intact, can you change the software?**  Yes  No  N/A

*It is acceptable to break the "seal" and load new software, audit trail is also a sufficient seal.*

- 1.3. The software documentation contains:
- 1.3.1. Description of all functions, designating those that are considered metrologically significant.  Yes  No  N/A
  - 1.3.2. Description of the securing means (evidence of an intervention).  Yes  No  N/A
  - 1.3.3. Software Identification, including version/revision. **It may also include things like name, part number, CRC, etc.**  Yes  No  N/A
  - 1.3.4. Description how to check the actual software identification.  Yes  No  N/A

- 1.4. The software identification is:
- 1.4.1. Clearly assigned to the metrologically significant software and functions.  Yes  No  N/A
  - 1.4.2. Provided by the device as documented.  Yes  No  N/A
  - 1.4.3. Directly linked to the software itself. **This means that you can't easily change the software without changing the software identifier. For example, the version identifier can't be in a text file that's easily editable, or in a variable that the user can edit.**  Yes  No  N/A

**2. Programmable or Loadable Metrologically Significant Software**

- 2.1. The metrologically significant software is:
- 2.1.1. Documented with all relevant (see below for list of documents) information. *The list of docs referred to exists in agenda Item 5.*  Yes  No  N/A
  - 2.1.2. Protected against accidental or intentional changes.  Yes  No  N/A

2.2. Evidence of intervention (such as, changes, uploads, circumvention) is available until the next verification/inspection (e.g., physical seal, Checksum, Cyclical Redundancy Check (CRC), audit trail, etc. means of security).  Yes  No  N/A

**3. Software with no access to the operating system and/or programs possible for the user. This section and Section 4 are intended to be mutually exclusive. Complete this section only if you replied Yes to 1.1.**

3.1. Check whether there is a complete set of commands (e.g., function keys or commands via external interfaces) supplied and accompanied by short descriptions.  Yes  No  N/A

3.2. Check whether the manufacturer has submitted a written declaration of the completeness of the set of commands.  Yes  No  N/A

**4. Operating System and/or Program(s) Accessible for the User. Complete this section only if you replied No to 1.1.**

4.1. Check whether a checksum or equivalent signature is generated over the machine code of the metrologically significant software (program module(s) subject to legal control Weights and Measures jurisdiction and type-specific parameters). This is a declaration or explanation by the manufacturer.  Yes  No  N/A

4.2. Check whether the metrologically significant software will detect and act upon any unauthorized alteration of the metrologically significant software using simple software tools (e.g., text editor). This is a declaration or explanation by the manufacturer.  Yes  No  N/A

**5. Software Interface(s)**

5.1. Verify the manufacturer has documented:

5.1.1. If software separation is employed, the program modules of the metrologically significant software are defined and separated.  Yes  No  N/A

5.1.2. For software that can access the operating system or if the program is accessible to the user, the protective software interface itself is part of the metrologically significant software.  Yes  No  N/A

5.1.3. The functions of the metrologically significant software that can be accessed ~~via the protective software interface.~~  Yes  No  N/A

5.1.4. The metrologically significant parameters that may be exchanged ~~via the protective software interface~~ are defined.  Yes  No  N/A

5.1.5. The description of the functions and parameters are conclusive and complete.  Yes  No  N/A

5.1.6. There are software interface instructions for the third party (external) application programmer.  Yes  No  N/A

**Conclusion:**

The Sector discussed examples, such as the upgrade of application programs and how these changes would affect audit trails and version numbers. It should be clear that if the upgraded software doesn't affect anything metrologically significant, then it's irrelevant for the purposes of this checklist. On the other hand, if it does affect metrologically significant functions or parameters, it should be tracked and/or identified somehow.

The revised checklist will be reviewed and further edited as required, and the updated version can be sent to the labs.

#### 4. Software Maintenance and Reconfiguration

**Source:**

NTEP Software Sector

**Background:**

After the software is completed, what do the manufacturers use to secure their software? The following items were reviewed by the Sector. *Note that agenda Item 3 also contains information on Verified and Traced updates and Software Log.*

1. Verify that the update process is documented. (OK)
2. For traced updates, installed Software is authenticated and checked for integrity

Technical means shall be employed to guarantee the authenticity of the loaded software (i.e., it originates from the owner of the type approval certificate). This can be accomplished (e.g., by cryptographic means like signing). The signature is checked during loading. If the loaded software fails this test, the instrument shall discard it and either use the previous version of the software **or become inoperative**.

Technical means shall be employed to guarantee the integrity of the loaded software i.e. that it has not been inadmissibly changed before loading. This can be accomplished (e.g., by adding a checksum or hash code of the loaded software and verifying it during the loading procedure). If the loaded software fails this test, the instrument shall discard it and either use the previous version of the software **or become inoperative**.

Examples are not limiting or exclusive.

3. Verify that the sealing requirements are met,

The Sector asked, “What sealing requirements are we talking about”?

This item is **only** addressing the **software update**; it can be either verified or traced. It is possible that there are two different security means, one for protecting software updates (software log) and one for protecting the other metrological parameters (Category I II or III method of sealing). Some examples provided by the Sector members include but are not limited to:

- Physical Seal, software log; and
- Category III method of sealing can contain both means of security.

4. Verify if the upgrade process fails, the device is inoperable or the original software is restored,

The question before the group is, “Can this be made mandatory”?

The manufacturer shall ensure by appropriate technical means (e.g., an audit trail) that traced updates of metrologically significant software are adequately traceable within the instrument for subsequent verification and surveillance or inspection. This requirement enables inspection authorities, which are responsible for the metrological surveillance of legally controlled instruments, to back-trace traced updates of metrologically significant software over an adequate period of time (that depends on national legislation). The statement in *italics* will need to be reworded to comply with U.S. weights and measures requirements.

The Sector **agreed** that the two definitions below for Verified update and Traced update were acceptable.

**Verified Update**

A verified update is the process of installing new software where the security is broken and the device must be re-verified. Checking for authenticity and integrity is the responsibility of the owner/user.



### **Traced Update**

A traced update is the process of installing new software where the software is automatically checked for authenticity and integrity, and the update is recorded in a software update log or audit trail.

*Note: It's possible that the Philosophy of Sealing section of NCWM Publication 14 may already address the above IF the definitions of Verified and Traced Updates (and the statement below) were to be added. The contrary argument was that it may be better to be explicit.*

**Use of a Category 3 audit trail is required for a Traced Update. A log entry representing a traced software update shall include the software identification of the newly installed version.**

The Sector recommended consolidating the definitions with the above statement thus:

### **Verified Update**

A verified update is the process of installing new software where the security is broken and the device must be re-verified. Checking for authenticity and integrity is the responsibility of the owner/user.

### **Traced Update**

A traced update is the process of installing new software where the software is automatically checked for authenticity and integrity, and the update is recorded in a ~~software update log or~~ Category 3 audit trail. The audit trail entry shall include the software identification of the newly installed version.

The Sector recommended that as a first step, the following be added to NCWM Publication 14:

**The updating of metrologically significant software, including software that checks the authenticity and integrity of the updates, shall be considered a sealable event.**

Mr. Truex, NTEP Administrator, believes the above sentence is unnecessary since it's self-evident. It was agreed to ask the other Sectors for feedback on the value of this addition.

Though the Sector is currently recommending only the single sentence be incorporated into NCWM Publication 14 for the time being, ultimately, the sector may wish to advance the remaining language of the original item submission.

At the 2013 meeting, the Sector had no information indicating that the other Sectors had yet been approached for feedback on the value of the addition of the proposed sentence. This Sector would still like the other Sectors to evaluate this for inclusion in NCWM Publication 14. We'd also like to include some description indicating that an existing audit trail should be protected during a software update, though that may already be a requirement. This does appear to be addressed in the Requirements for Metrological Audit Trails Appendices in NCWM Publication 14.

### **Discussion:**

In 2010 the Software Sector had considered the following:

**G-S.9. Metrologically Significant Software Updates – The updating of metrologically significant software shall be considered a sealable event. Metrologically significant software that does not conform to the approved type is not allowed for use.**

Mr. Ambler Thompson suggested that the notes under G-S.8. could be amended to include software updates as a new example. Mr. Rick Harshman recommended having it as a stand-alone item, such as discussed in 2010.

This could possibly be tied back to G-S.2.

What is the sealable parameter? Is it the software version/revision? Currently all of the parameters are user-selectable, which would make this unique.

If the general code in NIST Handbook 44 is amended to include this in some form, it applies to everything. The various Sectors don't need to add to their specific sections of NIST Handbook 44.

Mr. Darrell Flocken suggested that we try to come up with a declaration of intent and see how the Sectors respond. Mr. Doug Bliss will add it to the existing presentation. Mr. Jim Truex thought it might be valuable to obtain the opinion of the S&T Committee. The Legal Metrology group should be asked, "Is a software change that updates metrologically significant software a sealable event"? Rick Harshman can obtain an answer from them.

Mr. Thompson raised a concern about the fact that at this point none of the suggested wording requires the software identifier be unique (i.e., a change to the metrologically significant software should require a change to the software identifier). You could perhaps infer it from the requirement that it be inextricably linked to the software, but that isn't clear. Mr. thinks this will eventually need to be addressed, but not right now.

We reviewed the presentation that Mr. Doug Bliss had revised and tweaked it a bit. This sparked more discussion about the difficulty of convincing NIST. There seems to be a fundamental difference in how they understand changes of parameters and/or software. People don't seem to understand the difference between software and data. Adding a slide that explains the difference may help.

Last year's Weighing Sector feedback (Mr. Truex will provide their wording.) – they were opposed because:

1. It would change the methods of sealing (category 1, 2, and 3 audit trails) and require a change to NIST Handbook 44.
2. It's not clear that the requirement for authenticity and integrity of the updates is limited to metrologically significant software.

The other Sectors were concerned about this as well.

Legacy equipment that's still being manufactured might need to be changed to meet this obligation since their audit trails wouldn't necessarily indicate that the software has been updated.

Reference G-S.8., which is rather loose. NCWM Publication 14 goes into much more detail about what is metrologically significant.

Mr. Flocken referred to NIST Handbook 44, Scales code – the event logger category 3 – the software is not a parameter. It's not so much that the software would be tracked, as the fact that it has not been in the list of sealable parameters is the concern. It sounds like this may be a procedural issue – sections of NIST Handbook 44 may need to be altered before the Sectors can add this suggestion to NCWM Publication 14.

**Conclusion:**

After the discussion during the 2014 joint meeting, we revised the wording of the proposed G-S.9. to reflect some of the concerns heard from the other Sectors and interested parties:

**G-S.9. Metrologically Significant Software Updates – A software update that changes the metrologically significant software shall be considered a sealable event.**

The Sector still feels that explicitly requiring the metrologically significant software to be given at least the same level of protection as metrologically significant parameters is the best approach. We look forward to feedback from the S&T Committee and other Sectors on this proposed change. The Software Sector still would like to consider the issue of audit trail protection; there is some doubt as to whether the existing language is sufficient as it does not address the integrity of the audit trail during a software update, etc.

## 5. NTEP Application for Software and Software-based Devices

### Source:

NTEP Software Sector

### Background:

The purpose of initiating this item was to identify issues, requirements and processes for type approving Type U device applications. It was suggested that it may be useful to the labs to devise a separate submission form for software for Type U devices. What gets submitted? What requirements and mechanisms for submission should be available? Validation in the laboratories – all required subsystems shall be included to be able to simulate the system as installed.

Mr. Roach, California Division of Measurement Standards, stated that if the software package being evaluated supports platforms/subsystems from multiple manufacturers, testing should be done using at least two platforms/subsystems. Scale laboratories and scale manufacturers indicated that this is not usually done for scale evaluations.

Since the NTEP Committee passed the related item at NCWM Annual Meeting we will continue to work on this. Mr. Truex, NTEP Administrator, indicated that we can move in this direction, but felt that it was somewhat premature to develop this thoroughly now. At the point where the Sector has developed checklist requirements, then we could move to perhaps add a subsection to current NTEP applications for applicable software. Refer to D-31.6.1. It was also agreed that there seems to be no reason for limiting the scope of this item to software-only applications, and hence all software/software-based devices could benefit from an enhanced application process. Hence, the description of this agenda item was modified as shown in the marked up heading.

Comments given at the meeting indicate that current practice does not require anything different for software/software based devices compared to any other type approval. It was also noted that for international applications, OIML D-31.6.5 states, “The approval applicant is responsible for the provision of all the required equipment and components.” This would likely also be the policy of NTEP.

### Discussion:

Since the checklist is still being tried out by some of the laboratories, the Sector is not quite ready to develop this fully. Some documentation that eventually might be required by applicants could include (from WELMEC doc. 7-2 Issue 4): This is the list of documents referred to in the checklist.

- A description of the software functions that are metrologically significant, meaning of the data, etc. (e.g., an architecture diagram or flowchart).
- ~~A description of the accuracy of the measuring algorithms (e.g., price calculation and rounding algorithms).~~
- ~~A description of the user interface, communication interface, menus, and dialogs.~~
- The software identification (version, revision, etc.) and how to view it.
- ~~An overview of the system hardware, e.g., topology block diagram, type of computer(s), type of network, etc., if not described in the operating manual.~~
- An overview of the security aspects of the operating system (e.g., protection, user accounts, privileges, etc.)
- ~~The operating manual.~~

Mr. Flocken and Mr. Truex quickly reviewed existing requirements for documentation to be submitted for obtaining certification in Pub. 14, Administrative Policy, and on the application form itself. Administrative policy 9.1.7 was where this was found:

- Engineering specification; and
- Operating descriptions that characterize the type.

NTEP evaluators already have the authority to request whatever documentation they need. We can provide them with a list of documents that we think would assist the evaluator in his job and also give the manufacturer a good idea of what they should be capable of providing.

Mr. Flocken suggested that these additional items on our list could be added to administrative policy 9.1.7 in NCWM Publication 14. Mr. Truex suggested it could also be added to the application.

We struck the second bullet point because the labs probably won't care about this particular issue since they already have tests that they'll be running to address the accuracy of the measuring algorithms.

Mr. Russ Vires suggested removing some of the other bullet points, reducing the list to only new things to be added to the Administrative Policy. The list was originally designed to replace the current required documentation, so this would change its purpose. The original list was also never intended to be all-inclusive.

**Conclusion:**

If we combine the two lists, it might appear as something like this:

- A description of the software functions that are metrologically significant, meaning of the data, etc. (e.g., an architecture diagram or flowchart).
- A description of the user interface, communication interface, menus, and dialogs.
- The software identification (version, revision, etc.), and how to view it.
- An overview of the system hardware (e.g., topology block diagram, type of computer(s), type of network, etc.), if not described in the operating manual.
- An overview of the security aspects of the operating system (e.g., protection, user accounts, privileges, etc).
- The operating manual.
- Engineering specification.
- Operating descriptions that characterize the type.

A statement could be made along the lines of, "If not included in the operating manual, provide the following, as applicable."

After the last sentence in 9.1.7, this could be added:

**As part of the type evaluation submission, the following information should be provided for software-based devices:**

- **A description of the software functions that are metrologically significant, meaning of the data, etc., (e.g., an architecture diagram or flowchart).**
- **The software identification (version, revision, etc.) and how to view it.**
- **An overview of the security aspects of the operating system (e.g., protection, user accounts, privileges, etc.).**

These documentation requirements will be considered as input for requirements that will eventually appear in NCWM Publication 14 and the application paperwork. Further work by the Sector to develop the NCWM Publication 14 requirements is needed, after more input from the labs is gathered. The Sector recommends including the above bulleted list as an introduction to the checklist as part of our recommendation to include the checklist from agenda Item 3 in NCWM Publication 14. As a description of the accuracy of the measuring algorithms, simply declaring the type and class being aimed for may be sufficient. This list should reflect the needs of the labs for an evaluation. The bulleted list and the paragraph before it should be brought to the labs for an initial review and their input.

The Sector needs to discuss any input from the labs and finalize this list, prior to submitting the list to the other Sectors for incorporation into NCWM Publication 14.

## 6. Training of Field Inspectors

### Source:

NTEP Software Sector

### Background:

During discussions at the 2009 NTEP Software Sector Meeting, the Sector concluded that a new agenda item should be initiated specific to the training of field inspectors in relation to evaluating/validating software-based devices.

California has an Examination Procedure Outline (EPO) that begins to address this. Use “California Handbook 112” as a pattern template for how it could read.

Items to be addressed:

- Certificate of Conformance
- Terminology (as related to software) beyond what is in NIST Handbook 44.
- Reference materials / information sources

### System Verification Tests:

**NOTE:** Item numbers 1 through 5 apply to both weighing and measuring devices. Numbers 6 and 7 are specific to weighing devices; while numbers 9 and 10 apply to measuring devices.

1. **Identification.** – The identification (ID) tag may be on the back room computer server and could be viewed on an identification screen on the computer monitor. The ID information may be displayed on a menu or identification screen. Though currently discouraged, some systems may be designed so the system must be shut down and reset to view the ID information. G-S.1. [1.10]
  - 1.1. Manufacturer.
  - 1.2. Model designation.
2. Provisions for sealing. G-S.8. [1.10]; S.1.11. [2.20]; S.2.2. [3.30]
  - 2.1. Verify sealing category of device (refer to Certificate of Approval for that system).
  - 2.2. Verify compliance with certificate.
3. Units of measure.
  - 3.1. A computer and printer interfaced to a digital indicator shall print all metrological values, intended to be the same, identically. G-S.5.2.2.(a); G-S.5.1. [1.10]

- 3.2. The unit of measure, such as lb, kg, oz, gal, qt, liters, or whatever is used, must agree.
4. Operational controls, indications and features (buttons and switches). Verify that application criteria and performance criteria are met (refer to Certificate of Approval).
  - 4.1. Any indication, operation, function or condition must not be represented in a manner that interferes with the interpretation of the indicated or printed values.
5. Indications and displays.
  - 5.1. Attempt to print a ticket. The recorded information must be accurate or the software must not process and print a ticket with erroneous data interpreted as a measured amount.

**Weighing Devices:**

6. Motion detection.
  - 6.1. For railway track, livestock, and vehicle scales apply or remove a test load of at least 15d while simultaneously operating a print button, push-button tare or push-button zero. A good way to do this is to try to print a ticket while pulling the weight truck or another vehicle onto the scale. Recorded values shall not differ from the static display by more than 3d. Perform the test at 10 %, 50 % and 100 % of the maximum applied test load. S.2.5.1.(a) [2.20]; EPO NO. 2-3, 2.4
  - 6.2. For all other scales, apply or remove at least 5d. Printed weight values must agree with the static weight within 1d and must exactly agree with other indications. S.2.5.4.(b) [2.20]; EPO NO. 2-3, 2.4
7. Behind zero indication.
  - 7.1 Apply a load in excess of the automatic zero setting mechanism (AZSM) and zero the scale. S.2.1.3. [2.20]; EPO NO. 2-3, 2.4, 2.5.2  

Example: On a vehicle scale, have someone stand on the scale, then zero them off (AZSM is 3d). Remove the weight (person) and note the behind zero display (usually a minus weight value) or error condition.
  - 7.2. Attempt to print a ticket. With a behind zero condition, (manually or mechanically operated) a negative number must not be printed as a positive value.
8. Over capacity.
  - 8.1. Manually enter a gross weight if permissible or apply a test load in excess of 105 % of the scale's capacity. S.1.7. [2.20.]; S.1.12., UR.3.9. [2.20.]
  - 8.2. Attempt to print a weight ticket. A system must not print a ticket if the manually entered weight or load exceeds 105 % of the scale capacity.

**Measuring Devices**

9. Motion detection.
  - 9.1. Initiate flow through the measuring element. Attempt to print a ticket while the product is flowing through the measuring chamber. The device must not print while the indication is not stable. S.2.4.1. (3.30.)
10. Over capacity.
  - 10.1. Attempt to print a ticket in excess of the indicated capacity. A system must not print a ticket if the device is manually or mechanically operated in excess of the indicated value.

**NOTE:** Be aware of error codes on the indicator which may be interrupted as measured values.

The PDC is focused on training sessions at the moment, so it's unsure how much time they'd have to review this currently.

**Discussion:**

California has some direction for inspectors regarding third party software. Mr. Mike Wedman is currently tasked with revising and expanding some of California's documentation on the subject, and we asked him to share it with us when it is complete.

Is it California's Handbook 112? Mr. Wedman said they don't have such a handbook; it's in their device enforcement documentation.

NIST Handbook 112 doesn't have anything specific to software, and Mr. Truex says that this handbook has actually been out of production for years. Its last edition was in 2002. There's an online copy of it that was searched to verify if there was anything software-specific in it, and nothing was found.

Mr. Jim Pettinato proposed that we put together a group to begin writing something ourselves, and Mr. Truex stressed that it needed to be written at a level that the field inspectors would find useful.

**Conclusion:**

We'll wait until Mr. Wedman has completed his work on the California EPO. Mr. Pettinato, Mr. Teri Gulke, and Mr. Wedman volunteered to work on this offline.

The Sector would like to continue exploring means by which it can be of assistance in training of field inspectors as software and electronic systems become more and more prevalent in their daily tasks.

It was also suggested we contact Mr. Ross Anderson, a paid consultant working with the PDC Committee, to ask his opinion on how the Software Sector could best proceed to assist in the training of field inspectors. The Sector chair, Mr. Pettinato, will act as primary point of contact for this communication.

## NEW ITEMS

### 7. Next Meeting

**Background/Discussion:**

The Sector is on a yearly schedule for NTEP Software Sector Meetings. Now that we've adopted a joint meeting system, the next Sector joint meeting would likely be the Measuring Sector next October?

**Conclusion:**

The Measuring Sector normally meets the afternoon of Friday and all day Saturday, leading into Southern's meeting starting on Sunday. The labs meeting is Friday morning. Mr. Jim Truex recommended against us beginning Thursday and continuing into Friday as we will probably need an entire day overlapping with their schedule. Overlapping with them for the entire day of Saturday might be our best option, and then have a day to ourselves on Sunday.

We can't determine our precise schedule right now. We will have a one-day meeting in conjunction with the Measuring Sector (in addition to a one-day meeting of just the Software Sector), and it will be in the fall of 2015. Mr. Truex is going to try to determine what's possible.

## **8. 2014 NCWM Interim Meeting Report**

There was one item on the NCWM S&T Committee agenda for the 2013 NCWM Interim Meeting related to work done by the NTEP Software Sector. 2013 Publication 15, S&T Item 360-2 relates to the 2013 NTEP Software Sector Agenda Item 1: Marking Requirements.

From Jim Truex – the S&T Committee reported that it is considering withdrawing the item from their agenda if the Software Sector doesn't show some progress this year. By the end of August 28, 2014, this didn't seem like a likely result as we'd made significant progress on the item.

## **9. 2013 International Report**

Dr. Ambler Thompson, NIST, Office of Weights and Measures (OWM), will provide a synopsis of international activity that relates to the work of the Sector. Software Sector Co-Chair, Mr. Jim Pettinato will summarize the discussions that took place at the European Cooperation in Legal Metrology (WELMEC) WG7 meeting in December 2013.

Highlights of interest to the NTEP Software Sector:











- New WELMEC 7.2 draft document circulated for comment by WG7; and
- R-117 working group.



THIS PAGE INTENTIONALLY LEFT BLANK

### Sub-Appendix A

#### Acceptable Menu Text/Icons for Weights Measures information

<i>Permitted Menu Text examples</i>	<i>Permitted Icon shape examples</i>	<i>Essential characteristics</i>
Information  Info	  	Top level menu text or icon: <ul style="list-style-type: none"> <li>• Icon text is a lower case “i” with block serifs.</li> <li>• Text color may be light or dark but must contrast with the background color.</li> <li>• Icon may have a circular border.</li> <li>• Activation of this menu text/icon may invoke a second level menu text/icon that recalls metrology information.</li> </ul>
Help  ?	 	Top level menu text or icon: <ul style="list-style-type: none"> <li>• Icon text is a question mark.</li> <li>• Text color may be light or dark but must contrast with the background color.</li> <li>• Icon may have a circular border.</li> <li>• Activation of this menu text/icon may invoke a second level menu text/icon that recalls metrology information.</li> </ul>
Metrology  Metrological Information	 	Top or second level menu text or icon: <ul style="list-style-type: none"> <li>• Icon text is an upper case “M.”</li> <li>• Text color may be light or dark but must contrast with the background color.</li> <li>• Icon may have a circular, rectangular, or rounded rectangle border.</li> <li>• If present, the activation of this menu text/icon must recall at a minimum the NTEP CC number.</li> </ul>
NTEP Data  N.T.E.P. Certificate		This one is debatable – what if the certificate is revoked? Does NTEP grant holders of CCs the right to display the logo on the device, or just in documentation?
Weights & Measures Info	 	

This publication is available free of charge from: <https://doi.org/10.6028/NIST.SP.1210>

THIS PAGE INTENTIONALLY LEFT BLANK

## Sub-Appendix B Software Sector 2014 Goals Presentation

### SOFTWARE SECTOR 2014

#### Software Identification Goals (1/2)

- Each piece of physical equipment is unique and needs a serial number
- Software by itself is non-unique; it does **not** need a serial number
- All metrologically significant software, embedded or PC-based, needs version/revision identification
- Identification is best provided by the software itself; there is no guarantee that a hard-marked version/revision matches what is running

NTEP SOFTWARE SECTOR ACTIVITY 2013

#### Software Identification Goals (2/2)

- Metrologically significant software and its version/revision identification must be linked together; it must not be possible to modify the software without a change to its identification and vice versa.
- Changes to metrologically significant software made after placement in service must be evident

NTEP SOFTWARE SECTOR ACTIVITY 2013

## Effecting Desired Changes

- Handbook 44: Current marking requirements for software in GS-1 are different for built-for-purpose and not-built-for-purpose
- HB44 has wide reaching impact and changes are understandably scrutinized by all, difficult to modify
- New goal is to implement the consensus items with minimal impact on existing HB 44 language
- Propose to add explanations and clarifications of intent to Publication 14

NTEP SOFTWARE SECTOR ACTIVITY 2013

## Software Identification

- Software must be identified, preferably self
- Handbook 44 proposed change:
  - Software identification must be displayable or printable, unless impossible (applies to all metrologically significant software)
- Publication 14 proposed additions:
  - Define software separation and explain options to submit software either as a monolithic entity that includes metrologically significant software or as a separated piece of metrologically significant software
  - Explain that metrologically significant software and its version/revision identifier must be linked together

NTEP SOFTWARE SECTOR ACTIVITY 2013

## Recommended Additions to Publication 14

### **“Identification of Certified Software:**

*Note: Manufacturers may choose to separate metrologically significant software from non-metrologically significant software. Separation would allow the revision of the non-metrological portion without the need for further evaluation. In addition, non-metrologically significant software may be updated on devices without breaking a seal, if so designed. Separation of software requires that all software modules (programs, subroutines, objects etc.) that perform metrologically significant functions or that contain metrologically significant data domains form the metrologically significant software part of a measuring instrument (device or sub-assembly). If the separation of the software is not possible or needed, then the software is metrologically significant as a whole. The conformity requirement applies to all parts and parts shall be marked according to Section G-S-X.X.*

*The manufacturer must describe and possibly demonstrate how the version or revision identifier is directly and inseparably linked to the metrologically significant software. Where the version revision identifier is comprised of more than one part, the manufacturer shall describe which portion represents the metrologically significant software and which does not.”*

NTEP SOFTWARE SECTOR ACTIVITY 2013

## Software Protection

- Update of metrologically significant software must be protected
  - **Physical seal can protect software update but current event counters/audit trails may not**
  - **No clear requirement for counters/event log to either take note of, or survive a software update intact**
- Publication 14 proposed addition:
  - **Update of metrologically significant software becomes a sealable event**

NTEP SOFTWARE SECTOR ACTIVITY 2013

## Recommended Additions to Publication 14

*“The updating of metrologically significant software, including software that checks the authenticity and integrity of the updates, shall be considered a sealable event.”*

NTEP SOFTWARE SECTOR ACTIVITY 2013

### Software Update

- Metrologically significant software contains algorithms, methods and procedures that operate on data, which includes both sealable and non-sealable parameters.
- Today, type approval evaluation considers protecting the modification of sealable parameters but ignores protecting the software that manipulates those sealable parameters.

NTEP SOFTWARE SECTOR ACTIVITY 201

### Software Update (cont.)

- Equipment protected by a physical seal may prevent the update of software unless a seal is broken and provides evidence of software update.
- Event Counter & Event Logger sealing methods lack any requirement for such protection today.
- Software Sector believes that the field update of metrologically significant software is at least as important as the field change of a metrologically significant parameter – either can adversely impact a future measurement result.
- Metrologically significant software update should be a sealable event.

NTEP SOFTWARE SECTOR ACTIVITY 201



## Future Vision

- Make Software Sector more visible/transparent
  - **Educate & better explain Software Sector objectives**
- Improve communication with other Sectors
  - **Propose to overlap Software Sector meetings with other Sector meetings to better align Publication 14 changes and speed up the consensus process**
- Finalize definition of 'easily recognizable' menu selections/icons to display software identification
- Provide checklists for software evaluations
- Assist in software-specific field training curriculum

NTEP SOFTWARE SECTOR ACTIVITY 2013

## Sub-Appendix C

### Attendees

**Doug Bliss**

Mettler-Toledo, LLC  
1150 Dearborn Drive  
Worthington, OH 43085  
P. (614) 438-4307  
F. (614) 438-4355  
E. doug.bliss@mt.com

**Tom Buck**

Ohio Department of Agriculture  
8995 East Main Street  
Reynoldsburg, OH 43068  
P. (614) 728-6290 F. (614) 728-6424  
E. tom.buck@agri.ohio.gov

**Darrell Flocken**

National Conference on Weights and Measures  
1135 M Street, Suite 110  
Lincoln, NE 68508  
P. (614) 620-6134  
E. darrell.flocken@ncwm.net

**Andy Gell**

FOSS North America  
8091 Wallace Road  
Eden Prairie, MN 55344  
P. (952) 974-9892  
F. (800) 547-6275  
E. agell@fossna.com

**Teri Gulke**

Liquid Controls  
105 Albrecht Drive  
Lake Bluff, IL 60044-2242  
P. (847) 283-8346  
F. (847) 295-1170  
E. tgulke@idexcorp.com

**Tony Herrin**

Cardinal Scale Manufacturing Co.  
203 E. Daugherty  
Webb City, MO 64870  
P. (417) 673-4631  
E. therrin@cardet.com

**Paul A. Lewis, Sr.**

Rice Lake Weighing Systems, Inc.  
230 W. Coleman St.  
Rice Lake, WI 54868  
P. (715) 234-6967  
E. plewis@ricelake.com

**Edward McIntosh**

F-RAMS, Inc.  
P.O. Box 2964  
Georgetown, TX 78627  
P. (512) 868-8101  
E. f-rams@mindspring.com

**Eric Morabito**

New York State W&M  
10 B Airline Drive  
Albany, NY 12206  
P. (518) 457-3452  
E. eric.morabito@agriculture.ny.gov

**Christopher (Adam) Oldham**

Gilbarco, Inc.  
7300 West Friendly Avenue  
High Point, NC 27420  
P. (336) 547-5952  
E. adam.oldham@gilbarco.com

**Edward Payne**

Maryland Department of Agriculture  
50 Harry S. Truman Parkway  
Annapolis, MD 21401  
P. (410) 841-5790  
E. edward.payne@maryland.gov

**James M. Pettinato, Jr.**

Senior Software Engineer  
FMC Technologies, Inc.  
1602 Wagner Ave.  
P. (814) 898-5000  
E. jim.pettinato@fmcti.com

**Ambler Thompson**

NIST, Office of Weights and Measures  
100 Bureau Drive, MS 20600  
Gaithersburg, MD 21701  
P. (301) 975-2333  
E. [ambler@nist.gov](mailto:ambler@nist.gov)

**Zacharias Tripoulas**

Maryland Department of Agriculture  
50 Harry S. Truman Parkway  
Annapolis, MD 21401  
P. (410) 841-5790  
F. (410) 841-2765  
E. [zacharias.tripoulas@maryland.gov](mailto:zacharias.tripoulas@maryland.gov)

**Jim Truex**

National Conference on Weights and Measures  
1135 M Street, Suite 110  
Lincoln, NE 68508  
P. (740) 919-4350  
F. (740) 919-4348  
E. [jim.truex@ncwm.net](mailto:jim.truex@ncwm.net)

**Mike Wedman**

California Division of Measurement Standards  
6790 Florin Perkins Road, Suite 100  
Sacramento, CA 95828  
P. (916) 229-3014 F. (916)229-3026  
E. [mike.wedman@cdfa.ca.gov](mailto:mike.wedman@cdfa.ca.gov)

**Kraig Wooddell**

Hobart Corporation  
701 Ridge Avenue  
Troy, OH 485374  
P. (937) 332-2238  
E. [kraig.wooddell@hobartcorp.com](mailto:kraig.wooddell@hobartcorp.com)

*Note: The first day of the Software Sector meeting was held in conjunction with the NTEP Weighing Sector whose attendees were also present.*

## Appendix F

# National Type Evaluation Program (NTEP) Weighing Sector Meeting Summary

August 26-27, 2014  
Atlanta, Georgia

## INTRODUCTION

The charge of the NTEP Weighing Sector is important in providing appropriate type evaluation criteria based on specifications, tolerances, and technical requirements of NIST Handbook 44, *Specifications, Tolerances, and Other Technical Requirements for Weighing and Measuring Devices*, Sections 1.10. General Code, 2.20. Scales, 2.22. Automatic Bulk Weighing Systems, and 2.24. Automatic Weighing Systems. The Sector’s recommendations will be presented to the National Type Evaluation Program (NTEP) Committee each January for approval and inclusion in NCWM Publication 14, *Technical Policy, Checklists, and Test Procedures* for national type evaluation.

The Sector is also called upon occasionally for technical expertise in addressing difficult NIST Handbook 44, *Specifications, Tolerances, and Other Technical Issues* on the agenda of National Conference on Weights and Measures (NCWM) Specifications and Tolerances (S&T) Committee. Sector membership includes industry, NTEP laboratory representatives, technical advisors, and the NTEP Administrator. Meetings are held annually, or as needed and are open to all NCWM members and other registered parties.

Proposed revisions to the handbook(s) are shown as follows: 1) deleted language is indicated with a **bold face font using strikeouts** (e.g., ~~this report~~), 2) proposed new language is indicated with an **underscored bold faced font** (e.g., new items), and 3) nonretroactive items are identified in *italics*. There are instances where the Sector will use **red** text and/or **highlighted** text to bring emphasis to text that requires additional attention. When used in this report, the term “weight” means “mass.”

**Note:** It is the policy of the National Institute of Standards and Technology (NIST) to use metric units of measurement in all of its publications; however, recommendations received by NCWM technical committees and regional weights and measures associations have been printed in this publication as submitted. Therefore, the report may contain references in inch-pound units.

---

**Table A**  
**Table of Contents**

---

<b>Title of Contents</b>	<b>NTEP Page F</b>
<b>INTRODUCTION</b> .....	<b>1</b>
<b>CARRY-OVER ITEMS</b> .....	<b>3</b>
1. Recommended Changes to NCWM Publication 14 Based on Actions at the 2014 NCWM Annual Meeting .....	3
1.a. DES Section 70. – Performance and Permanence Tests for Railway Track Scales Used to Weigh In-Motion .....	3
2. Acceptable Symbols/Abbreviations to Display the CC Number Via a Device’s User Interface .....	4
3. NCWM Publication 14 DES Checklists and Test Procedures Section 1 Marking – Applicable to Indicating, Weighing/Load-Receiving Elements and Complete Scales .....	14
<b>NEW ITEMS</b> .....	<b>14</b>
4. NIST Handbook 44 Scales Code Paragraph S.5.4 Relationship of Load Cell Verification Interval Value to the Scale Division .....	14

5. NCWM Publication 14 DES Section B. Certificate of Conformance Parameters, Subsection 8. Weighing Systems, Scales or Weighing/load-receiving elements Greater than 30 000 lb Capacity, Paragraph 8.3.2. Range of Parameters for Modular Scales ..... 17

6. NCWM Publication 14 DES Section 10. Provision for Metrological Sealing of Adjustable Components or Audit Trail ..... 19

7. NCWM Publication 14 ABWS Technical Policy Section E. Automatic Bulk Weighing Systems – NTEP On-Site Evaluation, and ABWS Checklists Paragraph 32 ..... 21

8. NIST Handbook 44 Scales Code Paragraph S.2.4. Level-Indicating Means and NCWM Publication 14, AWS Section 39 Level-Indicating Means - Portable Automatic Weighing Systems ..... 22

9. NCWM Publication 14 DES Section D. Substitution of Load Cells, Load Cells Section 5..... 26

10. NCWM Publication 14 Load Cells Section L. Procedures - Table 3. .... 28

11. VCAP Influence Testing of Weighing/Load Receiving Element with a Capacity ≤ 2000 LB ..... 30

12. NCWM Publication 14 DES Section 43. Zero-Tracking Mechanism..... 32

13. NCWM Publication 14 DES Section D. Substitution of Load Cells, Load Cells Section 5 ..... 33

**NEXT MEETING..... 35**

**ATTENDEES (WEIGHING SECTOR) ..... 37**

**ATTACHMENTS ..... 39**

Attachment to agenda Item-13: NCWM Publication 14 DES Section D. Substitution of Load Cells, Load Cells Section 5 – Handout provided by Mr. Steve Langford (Cardinal Scale Manufacturing) ..... 39

**Table B**  
**Glossary of Acronyms and Terms**

<b>Acronym</b>	<b>Term</b>	<b>Acronym</b>	<b>Term</b>
ABWS	Automatic Bulk Weighing Systems	NCWM	National Conference on Weights and Measures
AREMA	American Railway Engineering Maintenance-of-Way Association	NTEP	National Type Evaluation Program
AWS	Automatic Weighing Systems	OIML	International Organization of Legal Metrology
CC	Certificate of Conformance	OWM	Office of Weights and Measures
DES	Digital Electronic Scales	R	Recommendation
IZSM	Initial Zero-Setting Mechanism	SS	National Type Evaluation Program Software Sector
LMD	Liquid Measuring Device	S&T	Specifications and Tolerances Committee
MC	Measurement Canada	SMA	Scale Manufacturers Association
MRA	Mutual Recognition Agreement	WS	National Type Evaluation Program Weighing Sector

---

**Details of All Items**  
(In order by Reference Key)

---

**CARRY-OVER ITEMS**

**1. Recommended Changes to NCWM Publication 14 Based on Actions at the 2014 NCWM Annual Meeting**

**Source:**

Mr. Richard Harshman, National Institute of Standards and Technology (NIST), Office of Weights and Measures (OWM) Technical Advisor provided the Sector with specific recommendations for incorporating test procedures and checklist language based upon actions of the 2014 NCWM Annual Meeting. The Sector is asked to briefly discuss each item and, if appropriate, provide general input on the technical aspects of the issues.

**1.a. DES Section 70. – Performance and Permanence Tests for Railway Track Scales Used to Weigh In-Motion**

**Source:**

Mr. Ed Luthy, Schenck Process, LLC (2011, 2012, and 2013 Weighing Sector Agenda Items 6, 3, and 3 respectively)

**Background/Discussion:**

During the 2011 NTEP Weighing Sector Meeting, the Sector discussed a weigh in-motion system using new technology that utilizes continuous rails (no “rail gaps”) on the approaches and weighing areas of the scale. The submitter stated that the manufacturer is currently unable to offer this device for sale in the United States in commercial applications because current NTEP type evaluation criteria and NIST Handbook 44 requirements are written in such a way that makes it impossible for devices incorporating this new technology to comply. For example, NIST Handbook 44, Scales Code paragraph UR.2.4. Foundations, Supports, and Clearance requires clearance be provided around all live parts to the extent that no contacts may result. NCWM Publication 14, DES Section 70, Inspect the Scale, Item 4 Rail Gaps states that “the rail gaps should be set at 3/8 inch.” The *AAR Scale Handbook* includes language that allows 1/8 in to 5/8 in rail gaps. The members of the Sector agreed that they were not willing to recommend deleting references to the required gaps in the rail until it is proven that the new technology complies with the tolerances in NIST Handbook 44. Thus, the Sector recommended that the applicant move forward with performance testing to confirm that the new technology complies with the tolerances in NIST Handbook 44.

Performance testing of the system had not yet been completed when the WS met in 2012. The WS agreed to retain the item on its agenda because there remained an open NTEP application for the device and testing was thought to be ongoing.

During the 2013 WS meeting, Mr. Ed Luthy provided an update on the progress of the testing that had taken place. He reported that the device had met performance requirements for static and in-motion testing and was awaiting final permanence testing. Based on Mr. Luthy’s update, the WS agreed to remove the requirement for 3/8 in rail gaps specified in NCWM Publication 14, DES Section 70, “Inspect the Scale” 4. Rail Gaps (Page DES-115, 2013 Edition) and renumber subsequent sections.

**See the Interim Report of the 2014 NCWM S&T Committee Agenda Item 320-2 for additional background information on the item to amend NIST Handbook 44, Scales Code paragraph UR.2.4. Foundation, Supports, and Clearance.**  
([http://www.ncwm.net/resources/dyn/files/1025938z8fff0401/\\_fn/2013\\_ST\\_Pub16.pdf](http://www.ncwm.net/resources/dyn/files/1025938z8fff0401/_fn/2013_ST_Pub16.pdf)).

**Conclusion:**

No action was recommended nor taken by the Sector on this item. The Sector agreed in 2014 to amend NCWM Publication 14 by removing the requirement for rail gaps in DES Section 70, “Inspect the Scale” 4. Rail Gaps and renumbering subsequent sections.

This item was carried over on the Sector's 2014 agenda because of the existence of a current proposal to amend NIST Handbook 44, which related to this Sector item. The following update was provided by the NIST Technical Advisor to make members of the WS aware of the action taken during the 2014 NCWM Annual Meeting on that proposal:

During the 2014 NCWM Annual Meeting, the Conference voted in favor of amending NIST Handbook 44, Scales Code paragraph UR.2.4. Foundations, Supports, and Clearance. The changes that were adopted provide an exception of having to provide clearance using rail gaps and applies only to in-motion railway track scales designed to be installed and operated using continuous rail.

The adoption of the proposal to amend Scales Code paragraph UR.2.4. by the NCWM concludes this item. It will not appear on the Sector's 2015 agenda.

## 2. Acceptable Symbols/Abbreviations to Display the CC Number Via a Device's User Interface

### Sources:

- 2009 NTETC Software Sector Agenda Item 3 and 2010 S&T Item 310-3 G-S.1. Identification. (Software)
- 2010 Final Report of the S&T Committee: [ncwm.net/content/annual-archive](http://www.ncwm.net/content/annual-archive)
- 2010 Software Sector summary: <http://www.ncwm.net/committees/ntep/sectors/software/archive>
- 2011 Software Sector summary: <http://www.ncwm.net/committees/ntep/sectors/software/archive>
- 2011 Final Report of the S&T Committee (Publication 16 and addendum sheets):  
[ncwm.net/content/annual-archive](http://www.ncwm.net/content/annual-archive)
- 2012 Software Sector summary: <http://www.ncwm.net/committees/ntep/sectors/software/archive>
- 2012 Final Report of the S&T Committee:  
[http://www.ncwm.net/resources/dyn/files/1025938z8fff0401/\\_fn/2013\\_ST\\_Pub16.pdf](http://www.ncwm.net/resources/dyn/files/1025938z8fff0401/_fn/2013_ST_Pub16.pdf)
- 2013 Software Sector Summary:  
[http://www.ncwm.net/resources/dyn/files/981560z45f7a5f5/\\_fn/12\\_Software\\_Sector\\_Activity.pdf](http://www.ncwm.net/resources/dyn/files/981560z45f7a5f5/_fn/12_Software_Sector_Activity.pdf)
- 2013 Final Report of the S&T Committee: <http://www.nist.gov/pml/wmd/pubs/sp1171.cfm>
- 2014 Final Report of the S&T Committee:  
<http://www.nist.gov/pml/wmd/pubs/upload/08-st-14-annual-final.pdf>

### Background:

Local weights and measures inspectors need a means to determine whether equipment discovered in the field has been evaluated by NTEP. If so, the inspector needs to know at a minimum the CC number. From this starting point, other required information can be ascertained (e.g., the software version or revision identifier of the software installed in an electronic device at the time it was evaluated). NIST Handbook 44 currently includes three options for marking of the CC:

1. permanent marking;
2. continuous display; and
3. recall using a special operation.

Additional background information relative to this item can be found in 2014 NCWM Publication 16 at:

[http://www.ncwm.net/resources/dyn/files/1217541z1019c056/\\_fn/4-ST-Pub16-2014-CORRECTED-06-12-2014.pdf](http://www.ncwm.net/resources/dyn/files/1217541z1019c056/_fn/4-ST-Pub16-2014-CORRECTED-06-12-2014.pdf)

During its 2013 meeting, the WS, at the request of the SS, reviewed and provided feedback on the following SS proposal to amend NIST Handbook 44, General Code Paragraphs G-S.1. Identification and G-S.1.1. Location of Marking Information for Not-Built-for-Purpose, Software-Based Devices:

**NIST Handbook 44 – Proposed changes:**

**G-S.1. Identification.** – All equipment, except weights and separate parts necessary to the measurement process but not having any metrological effect, shall be clearly and permanently marked for the purposes of identification with the following information:

- (a) the name, initials, or trademark of the manufacturer or distributor;
- (b) a model identifier that positively identifies the pattern or design of the device;
  - (1) *The model identifier shall be prefaced by the word “Model,” “Type,” or “Pattern.” These terms may be followed by the word “Number” or an abbreviation of that word. The abbreviation for the word “Number” shall, as a minimum, begin with the letter “N” (e.g., No or No.). The abbreviation for the word “Model” shall be “Mod” or “Mod.” Prefix lettering may be initial capitals, all capitals, or all lowercase.*  
[Nonretroactive as of January 1, 2003]  
(Added 2000) (Amended 2001)
- (c) a nonrepetitive serial number, except for equipment with no moving or electronic component parts and ~~not built for purpose software based software devices~~ **software**;  
[Nonretroactive as of January 1, 1968]  
(Amended 2003)
  - (1) *The serial number shall be prefaced by words, an abbreviation, or a symbol, that clearly identifies the number as the required serial number.*  
[Nonretroactive as of January 1, 1986]
  - (2) *Abbreviations for the word “Serial” shall, as a minimum, begin with the letter “S,” and abbreviations for the word “Number” shall, as a minimum, begin with the letter “N” (e.g., S/N, SN, Ser. No., and S. No.).*  
[Nonretroactive as of January 1, 2001]
- (d) the current software version or revision identifier ~~for not built for purpose software based electronic devices~~, which shall be directly linked to the software itself;  
[Nonretroactive as of January 1, 2004]  
(Added 2003) (**Amended 20XX**)
  - (1) *The version or revision identifier shall be prefaced by words, an abbreviation, or a symbol, that clearly identifies the number as the required version or revision.*  
[Nonretroactive as of January 1, 2007]  
(Added 2006)
  - (2) *Abbreviations for the word “Version” shall, as a minimum, begin with the letter “V” and may be followed by the word “Number.” Abbreviations for the word “Revision” shall, as a minimum, begin with the letter “R” and may be followed by the word “Number.” The abbreviation for the word “Number” shall, as a minimum, begin with the letter “N” (e.g., No or No.).*  
[Nonretroactive as of January 1, 2007]  
(Added 2006)
  - (3) **The version or revision identifier shall be accessible via the display. Instructions for displaying the version or revision identifier shall be described in the CC. As an exception, permanently marking the version or revision identifier shall be acceptable under the following conditions:**
    - 1. The user interface does not have any control capability to activate the indication of the version or revision identifier on the display, or the display does not technically allow the version or revision identifier to be shown (analog indicating device or electromechanical counter) or**
    - 2. the device does not have an interface to communicate the version or revision identifier.**



(e) an NTEP CC number or a corresponding CC Addendum Number for devices that have a CC.

- (1) *The CC Number or a corresponding CC Addendum Number shall be prefaced by the terms “NTEP CC,” “CC,” or “Approval.” These terms may be followed by the word “Number” or an abbreviation of that word. The abbreviation for the word “Number” shall, as a minimum, begin with the letter “N” (e.g., No or No.) [Nonretroactive as of January 1, 2003]*

The required information shall be so located that it is readily observable without the necessity of the disassembly of a part requiring the use of any means separate from the device.

(Amended 1985, 1991, 1999, 2000, 2001, 2003, ~~and~~ 2006 **and 201X**)

**G-S.1.1. Location of Marking Information for ~~Not-Built-For-Purpose~~ All Software-Based Devices.** —For ~~not-built-for-purpose~~ software-based devices, either:

- (a) *The required information in G-S.1. Identification. (a), (b), ~~(d)~~, and (e) shall be permanently marked or continuously displayed on the device; or*
- (b) *The CC Number shall be:*
- (1) *permanently marked on the device;*
- (2) *continuously displayed; or*
- (3) *accessible through an easily recognized menu and, if necessary, a submenu. Examples of menu and submenu identification include, but are not limited to, “Help,” “System Identification,” “G-S.1. Identification,” or “Weights and Measures Identification.”*

*Note: For (b), clear instructions for accessing the information required in G-S.1. (a), (b), and (d) shall be listed on the CC, including information necessary to identify that the software in the device is the same type that was evaluated. [Nonretroactive as of January 1, 2004]*

(Added 2003) (Amended 2006 **and 20XX**)

See the 2013 WS Final Report to view the feedback provided by the WS on the SS’s proposal to amend paragraphs G-S.1. and G-S.1.1. and for additional background information relating to this item.

This item was also a “Developing” item on the 2014 S&T Committee’s agenda and remains so on the 2015 S&T Committee’s agenda. During the 2014 NCWM Annual Meeting, NIST OWM provided the following comments concerning the SS’s proposal:

The following two concerns and suggestions were provided concerning the changes proposed to subparagraph G-S.1.(d):

1. Deleting the words “for not-built-for-purpose software-based electronic devices” creates the implication that all equipment manufactured as of January 1, 2004, except weights and separate parts necessary to the measurement process but not having any metrological effect, would be required to be permanently marked with a current software version or revision identifier. OWM questions whether or not it is the Software Sector’s intent to require a software version or revision identifier be marked on equipment that is not electronic. If not the intent, OWM suggests that the Sector consider adding text to better clarify the type of equipment intended to be addressed by this proposed change and offers the following additional text for consideration:

- (d) the current software version or revision identifier **for software-based electronic devices**, which shall be directly linked to the software itself;

2. The proposed changes, if adopted, would require a current software version or revision identifier be marked on both built-for-purpose and not-built-for purpose software based equipment manufactured as of January 1, 2004. If it is the intent of the Sector to require that a current software version or revision identifier be marked on built-for-purpose software based equipment, then the Sector might consider proposing that such a requirement be non-retroactive or that it become enforceable at some future date considering the time and cost involved in updating equipment already in service.

The following additional feedback was provided by OWM concerning the Software Sector's proposed changes to paragraphs G-S.1. and G-S.1.1.:

- It is not clear what equipment would be affected by the proposed changes to G-S.1.(c). By proposing that the word "software" be added, is the exception intended to apply to the software itself or to equipment in which the software is installed?
- In the proposed additions to G-S.1.(d)(3)(a), it is not clear what is meant by the phrase "or the display does not technically allow the version or revision identifier to be shown." The examples "analog indicating device" and "electromechanical counter" do not provide enough information to lead one to conclude that the intent is to address such things as numeric-only displays. That is, numeric-only displays that don't have the capability of displaying abbreviations for "version" or "revision" as noted in earlier comments originating from the Sector.
- OWM recommends adding some examples to clarify the types of devices described in paragraph G-S.1.(d)(3)(b).
- OWM agrees with the Software Sector's assertion that it may be possible to eventually eliminate G-S.1.1. at some future date.

OWM noted that a joint meeting of the Software and Weighing Sectors is planned in August 2014 to consider the current proposal and to try and reach agreement on the changes necessary to paragraph G-S.1. OWM encouraged the two Sectors to consider its comments and feedback when considering any changes to the language currently proposed for G-S.1. The approach used in the past has been for the Sectors to review the proposal in separate meeting sessions; however, this has not resulted in a proposal amenable to all Sectors. OWM believes that it might be more expedient for all of the Sectors to collaborate in a single joint meeting to try and reach agreement on the changes needed.

Following the 2014 NCWM Annual Meeting, members of OWM's Legal Metrology Devices Program (LMDP) were requested to provide additional input on the proposal to modify G-S.1. and G.S.1.1. in consideration of the goals of the SS and the comments provided during the 2014 Open Hearings of the S&T Committee relating to this item.

The following is a list of the goals provided by the SS in modifying G-S.1. and G.S.1.1. as communicated to the members of OWM's LMDP:

1. Remove the existing distinction between software identification requirements for built-for-purpose and not-built-for-purpose devices.
2. To require that all software-based devices have a software version or revision identifier for metrologically significant software.
3. Require that certified software versions or revision identifiers for metrologically significant software is recorded on the CC for access by inspectors.
4. Software itself does not require serial numbers.

5. Require that software-based devices version or revision identifier shall be accessible via the display and user interface and only if device's display is incapable of displaying the identifier or has no display and/or interface; then permanently marking the version or revision identifier shall be acceptable (e.g., digital load cell).
6. Nonretroactive as of January 1, 2016, if passed by the NCWM in July 2015.

OWM's LMDP developed the following proposed draft alternative changes to G-S.1. based on the SS's request for additional input on how best to meet its goals and forwarded them to the Chairman of the SS for consideration at the 2014 WS/SS joint meeting:

Amend NIST Handbook 44: G-S.1. Identification and G-S.1.1. Location of Marking Information for Not-Built-For-Purpose, Software-Based Devices as follows:

**G-S.1. Identification.** – All equipment, except weights and separate parts necessary to the measurement process but not having any metrological effect, shall be clearly and permanently marked for the purposes of identification with the following information:

- (a) the name, initials, or trademark of the manufacturer or distributor;
- (b) a model identifier that positively identifies the pattern or design of the device;
  - (1) *The model identifier shall be prefaced by the word "Model," "Type," or "Pattern." These terms may be followed by the word "Number" or an abbreviation of that word. The abbreviation for the word "Number" shall, as a minimum, begin with the letter "N" (e.g., No or No.). The abbreviation for the word "Model" shall be "Mod" or "Mod." Prefix lettering may be initial capitals, all capitals, or all lowercase.*  
*[Nonretroactive as of January 1, 2003]*  
(Added 2000) (Amended 2001)
- (c) *a nonrepetitive serial number, except for equipment with no moving or electronic component parts and ~~not built for purpose software based devices~~ software;*  
*[Nonretroactive as of January 1, 1968]*  
(Amended 2003)
  - (1) *The serial number shall be prefaced by words, an abbreviation, or a symbol, that clearly identifies the number as the required serial number.*  
*[Nonretroactive as of January 1, 1986]*
  - (2) *Abbreviations for the word "Serial" shall, as a minimum, begin with the letter "S," and abbreviations for the word "Number" shall, as a minimum, begin with the letter "N" (e.g., S/N, SN, Ser. No., and S. No.).*  
*[Nonretroactive as of January 1, 2001]*
- (d) the current software version or revision identifier for not-built-for-purpose software-based devices; **manufactured as of January 1, 2004 through December 31, 2015, and all software based devices or equipment manufactured as of January 1, 2016;**  
~~*[Nonretroactive as of January 1, 2004]*~~  
(Added 2003) **(Amended 20XX)**
  - (1) *The version or revision identifier shall be:*

- i. *prefaced by words, an abbreviation, or a symbol, that clearly identifies the number as the required version or revision;*  
*[Nonretroactive as of January 1, 2007]*  
(Added 2006)
- ii. ***directly linked to the software itself; and***  
***[Nonretroactive as of January 1, 2016]***  
(Added 20XX)
- iii. ***continuously displayed\* or be accessible via the display menus. Instructions for displaying the version or revision identifier shall be described in the CC. As an exception, permanently marking the version or revision identifier shall be acceptable providing the device does not have an integral interface to communicate the version or revision identifier.***  
***[Nonretroactive as of January 1, 2016]***  
(Added 20XX)

***\*The version or revision identifier shall be displayed continuously on software-based equipment with a digital display manufactured as of January 1, 20XX and all software-based equipment with a digital display as of January 1, 20XX.***

- (2) *Abbreviations for the word “Version” shall, as a minimum, begin with the letter “V” and may be followed by the word “Number.” Abbreviations for the word “Revision” shall, as a minimum, begin with the letter “R” and may be followed by the word “Number.” The abbreviation for the word “Number” shall, as a minimum, begin with the letter “N” (e.g., No or No.).*  
*[Nonretroactive as of January 1, 2007]*  
(Added 2006)

- (e) *a National Type Evaluation Program (NTEP) Certificate of Conformance (CC) number or a corresponding CC Addendum Number for devices that have a CC.*

***(1) The CC Number or a corresponding CC Addendum Number shall be prefaced by the terms “NTEP CC,” “CC,” or “Approval.” These terms may be followed by the word “Number” or an abbreviation of that word. The abbreviation for the word “Number” shall, as a minimum, begin with the letter “N” (e.g., No or No.).***  
*[Nonretroactive as of January 1, 2003]*

The required information shall be so located that it is readily observable without the necessity of the disassembly of a part requiring the use of any means separate from the device. (Amended 1985, 1991, 1999, 2000, 2001, 2003, ~~and~~, 2006 ~~and~~ 20XX)

***G-S.1.1. Location of Marking Information for ~~Not-Built-For-Purpose~~ All Software-Based Devices. – For ~~not-built-for-purpose~~, software-based devices, either:***

- (a) *The required information in G-S.1. Identification. (a), (b), ~~(d)~~, and (e) shall be permanently marked or continuously displayed on the device; or*
- (b) *The CC Number shall be:*
  - (1) *permanently marked on the device;*
  - (2) *continuously displayed; or*

(3) *accessible through an easily recognized menu and, if necessary, a submenu. Examples of menu and submenu identification include, but are not limited to, “Help,” “System Identification,” “G-S.1. Identification,” or “Weights and Measures Identification.”*

**Note:** For (b), clear instructions for accessing the information required in G-S.1. (a), (b), and (d) shall be listed on the CC, including information necessary to identify that the software in the device is the same type that was evaluated.

[Nonretroactive as of January 1, 2004]

(Added 2003) (Amended 2006 **and 20XX**)

No changes to subparagraph G-S.1.1. were proposed by OWM’s LMDP since the SS had indicated earlier that it may be possible to eventually eliminate G-S.1.1. Thus, the proposed changes to subparagraph G-S.1.1. shown above in OWM’s draft alternative changes are those originating from the SS’s 2013 proposal.

In providing feedback to the SS, OWM’s LMDP noted that the shaded portion of G-S.1.(d)(1)iii. of their draft alternative changes was developed solely by OWM (i.e., does not reflect any of the goals communicated by the SS) and was being offered for consideration with the understanding that:

1. this change will make it easier in the future for inspectors to be able to identify software installed in equipment;
2. a reasonable amount of time for the changes to take effect can be specified; and
3. it is probable that improvements in technology over time will make it easier for equipment manufacturers to comply.

In addition to the alternative changes proposed by OWM’s LMDP, a member of the SS submitted the following definition of “software-based devices” for discussion during the joint meeting of the Weighing and Software Sectors and possible future inclusion into Appendix D of NIST Handbook 44:

**software-based devices.** – devices used to compute and control processes using software, where software is a general term for the programs and data used to operate the computers and/or related electronic devices. Software-based device may also consist of just software (e.g., weigh in/weigh out software).

#### **Discussion/Conclusion:**

During the joint meeting of the Weighing and Software Sectors, the Chairman of the SS led a discussion on the identification of software; more specifically, the changes that have been proposed or that are needed to G-S.1. and G-S.1.1. and the reasons why these changes are important. He reviewed the SS’s 2013 draft proposal to amend G-S.1. and G-S.1.1. and the comments that had been received since its distribution. Very few constructive comments had been received except for some comments provided by NIST, OWM, which the Chairman reviewed one by one; requesting additional clarification from the NIST Technical advisor as needed.

Once the review of the Sector’s draft proposal had been completed, it was then pointed out that NIST OWM’s LMDP had developed some suggested alternative changes to the SS’s proposal at the request of the SS. Members of both Sectors were asked to review and consider the alternative changes proposed by OWM’s LMDP, which were provided in a handout to members of both sectors and displayed on screen.

The NIST Technical Advisor to the WS, also a member of OWM’s LMDP, explained the reasons for OWM’s proposed alternative changes to G-S.1. Identification. Initial discussions of the group regarding OWM’s draft changes mostly concentrated on three main issues/concerns as follows:

1. Why is it necessary to retain the term “not-built-for-purpose software-based devices” and add enforcement dates to G-S.1.(d) when it is the Sector’s intention to treat built-for-purpose and not-built-for-purpose devices the same with respect to identifying software?
2. Consideration of the text that OWM had developed and was proposing for addition to G-S.1.(d) iii.
3. What would be the effective dates of any changes agreed upon by the group?

The following is a brief summary of the discussions and actions taken by the two Sectors relative to these three issues/concerns:

1. With regard to the changes proposed to G-S.1.(d), the NIST Technical Advisor to the WS indicated that it was OWM’s view that a separation between built-for purpose and not-built-for-purpose software-based devices needed to be maintained within the paragraph because the current requirement (i.e., G-S.1.(d)) only applies to not-built-for-purpose software-based devices. Although the SS’s intention is to expand the requirement to apply to all electronic devices, it would not be appropriate to require existing built-for-purpose-equipment, which is already in service, to comply with the proposed changes to G-S.1. since this equipment has not had to do so previously. Updating existing equipment, in order to make it comply with new requirements, could be costly to both manufacturers and device owners. Additionally, it may not be possible for some built-for-purpose devices to provide an indication of the current software version or revision identifier. Although marking of the version or revision identifier using a label affixed to the device might be an option, how would officials be able to tell if the version of software installed in the device actually matched the marking on the device? By adding effective dates, as proposed, the separation can be maintained and still provide a means of requiring all new electronic equipment to comply. The NIST Technical Advisor also acknowledged that it may be possible at some future date to remove the reference to “not built for-purpose” in the paragraph. Members of the two Sectors agreed, although it was decided that the words “through December 31, 2015” in the lead-in sentence of G-S.1.(d) should be deleted because the inclusion of this date is not necessary and its removal does not in any way change the proposal.
2. There were significant concerns raised by equipment manufacturers regarding OWM’s suggested proposal to require the continuous display of the version or revision identifier on software-based equipment having a digital display. It was stated that some displays; specifically referenced were “seven-segment digital displays of simple design,” do not have the capability of complying with the proposed note that had been developed by OWM. It was also stated that customer demand for these simple displays remains steady among the different scale manufacturers because of their low cost in relation to other digital displays that incorporate more current and complex technology. That is, some customers aren’t willing to pay the extra money for a more complex display that can be made to comply with OWM’s proposed note, such as one of the graphic types, when all that’s needed is a simple basic display. Manufacturers did not see this situation changing and stated that sales of these displays are driven by their low cost. Another concern was the valuable “real estate” that the version or revision identifier would take up if it were continuously displayed.
3. In consideration of the fact that the proposed changes, if adopted, would require both built-for-purpose and not-built-for-purpose software-based equipment to continuously display the current software version or revision identifier or that this information be accessible via the display menus, members of the two Sectors felt that the 2016 effective date proposed by OWM did not provide enough lead-in time for equipment manufacturers. Thus, the Sectors agreed to extend the date to 2020 by amending OWM’s proposal to reflect this new date.

A fourth issue/concern, which was raised by an equipment manufacturer somewhat later in the discussions, is that some built-for-purpose equipment have limited capability of displaying letters of the alphabet, and therefore, unable to comply with the prefacing requirements specified in G-S.1.(d)(1) and G-S.1.(d)(2). The example provided was a seven-segment display. It is not able to display a “V” or an “R,” which are the current acceptable abbreviations for “version” and “revision,” respectively. A “U” could be considered a symbol; however, it is not currently a symbol included in the list of acceptable abbreviations found in some NCWM Publication 14 device checklists. Alternatively, a lower-case “r” could be displayed on such an indicator. In consideration of this concern, it was suggested that a “note” be added to G-S.1.(d) permitting the NTEP evaluators to specify a different method of indication if the device

is incapable of prefacing the software version/revision with a “V” or “R.” The Sectors agreed to propose a “note” be added and let the S&T Committee decide whether the “note” is necessary or appropriate. An additional change agreed upon by the Sectors relating to this issue/concern was to add the last sentence of G-S.1.(b) to the end of G-S.1.(d)(2). In discussing this issue/concern, it was also stated that some built-for-purpose devices only indicate the software version or revision identification during power up. That is, in order to view the software identification, it is necessary to shut off and then return power to the device. It was noted that some officials have been instructed not to power down equipment they are inspecting for liability reasons. There were no solutions to this (power down/power up) concern offered by members of either Sector.

Although the SS had earlier proposed changes to G-S.1.1., it was decided during the meeting that no changes to G-S.1.1. were necessary since the sectors had agreed to retain the term “not-built-for-purpose software-based devices” in G-S.1.(d). Thus, no changes are proposed to paragraph G-S.1.1. The following reflects all of the changes to paragraph G-S.1. that were agreed upon by the two Sectors during the joint meeting:

**Amend NIST Handbook 44: G-S.1. Identification as follows:**

**G-S.1. Identification.** – All equipment, except weights and separate parts necessary to the measurement process but not having any metrological effect, shall be clearly and permanently marked for the purposes of identification with the following information:

- (a) the name, initials, or trademark of the manufacturer or distributor;
- (b) a model identifier that positively identifies the pattern or design of the device;
  - (1) *The model identifier shall be prefaced by the word “Model,” “Type,” or “Pattern.” These terms may be followed by the word “Number” or an abbreviation of that word. The abbreviation for the word “Number” shall, as a minimum, begin with the letter “N” (e.g., No or No.). The abbreviation for the word “Model” shall be “Mod” or “Mod.” Prefix lettering may be initial capitals, all capitals, or all lowercase.*  
*[Nonretroactive as of January 1, 2003]*  
(Added 2000) (Amended 2001)
- (c) *a nonrepetitive serial number, except for equipment with no moving or electronic component parts and ~~not built for purpose software-based software devices~~ software;*  
*[Nonretroactive as of January 1, 1968]*  
(Amended 2003)
  - (1) *The serial number shall be prefaced by words, an abbreviation, or a symbol, that clearly identifies the number as the required serial number.*  
*[Nonretroactive as of January 1, 1986]*
  - (2) *Abbreviations for the word “Serial” shall, as a minimum, begin with the letter “S,” and abbreviations for the word “Number” shall, as a minimum, begin with the letter “N” (e.g., S/N, SN, Ser. No., and S. No.).*  
*[Nonretroactive as of January 1, 2001]*
- (d) the current software version or revision identifier for not-built-for-purpose software-based devices; **manufactured as of January 1, 2004, and all software-based devices or equipment manufactured as of January 1, 2020;**  
***[Nonretroactive as of January 1, 2004]***  
(Added 2003) **(Amended 20XX)**
  - (1) *The version or revision identifier shall be:*

- i. *prefaced by words, an abbreviation, or a symbol, that clearly identifies the number as the required version or revision;*  
[Nonretroactive as of January 1, 2007]  
(Added 2006)

**Note: If the equipment is capable of displaying the version or revision identifier but is unable to meet the formatting requirement, through the NTEP type evaluation process, other options may be deemed acceptable and described in the CC.**

**(Added 20XX)**

- ii. **directly linked to the software itself; and**  
**[Nonretroactive as of January 1, 2020]**  
**(Added 20XX)**

- iii. **continuously displayed or be accessible via the display. Instructions for displaying the version or revision identifier shall be described in the CC. As an exception, permanently marking the version or revision identifier shall be acceptable providing the device does not have an integral interface to communicate the version or revision identifier.**  
**[Nonretroactive as of January 1, 2020]**  
**(Added 20XX)**

- (2) *Abbreviations for the word “Version” shall, as a minimum, begin with the letter “V” and may be followed by the word “Number.” Abbreviations for the word “Revision” shall, as a minimum, begin with the letter “R” and may be followed by the word “Number.” The abbreviation for the word “Number” shall, as a minimum, begin with the letter “N” (e.g., No or No.). **Prefix lettering may be initial capitals, all capitals, or all lowercase.***  
[Nonretroactive as of January 1, 2007]  
(Added 2006)

- (e) *a National Type Evaluation Program (NTEP) Certificate of Conformance (CC) number or a corresponding CC Addendum Number for devices that have a CC.*

- (1) The CC Number or a corresponding CC Addendum Number shall be prefaced by the terms “NTEP CC,” “CC,” or “Approval.” These terms may be followed by the word “Number” or an abbreviation of that word. The abbreviation for the word “Number” shall, as a minimum, begin with the letter “N” (e.g., No or No.)**  
**[Nonretroactive as of January 1, 2003]**

The required information shall be so located that it is readily observable without the necessity of the disassembly of a part requiring the use of any means separate from the device.

(Amended 1985, 1991, 1999, 2000, 2001, 2003, **and**, 2006 **and** 201X)

Members of the two Sectors also reviewed the draft definition of “software-based devices.” The draft definition had been developed by a member of the SS in consideration of a comment that had been received by the S&T Committee during one of the 2014 NCWM Conferences. The Sectors agreed that no action was currently necessary other than that the definition be retained for future consideration should the need develop.

An additional issue that was discussed during the joint meeting is whether or not the updating of metrological software should be considered a sealable event or sealable parameter. It was agreed that an update to metrological software is a sealable event and needs to be protected using an approved means of security. The Sectors then considered whether it would be appropriate to include the updating of metrological software in the list of sealable parameters in NCWM Publication 14 or to provide for its security by proposing a new General Code requirement be added to NIST Handbook 44. The Sectors decided that the updating of metrological software can affect multiple sealable parameters,



and, therefore, it is appropriate to address its security in the General Code of NIST Handbook 44. Consequently, the Sectors decided to complete and submit an NCWM Form 15 proposing there be a new General Code requirement added to the handbook to address the security of software updates.

The two Sectors agreed that much progress had been made during the joint meeting, but that paragraph G-S.1., as revised during the meeting, is not likely to be considered for vote by the NCWM. In consideration of the progress that was made, the Sectors agreed to recommend that the “Developing” status of the item be changed to “Informational” and forward the revised draft of G-S.1. to the different regional associations for their consideration at their next meeting.

### **3. NCWM Publication 14 DES Checklists and Test Procedures Section 1 Marking – Applicable to Indicating, Weighing/Load-Receiving Elements and Complete Scales**

**Source:**

NTEP Labs – 2013 Weighing Sector Agenda Item 7.

**Background/Discussion:**

A “Note” in Section 1 of the Checklists and Procedures of NCWM Publication 14 Digital Electronic Scales specifies that for consistency purposes the NTEP labs use an Eberhard Faber ink eraser type #110 to verify the permanence of the lettering used to mark required information on a device. It has been reported that this particular eraser may no longer be available in the marketplace. The NTEP lab evaluators had been asked to try and identify a suitable replacement for this eraser; but none had been suggested as of the 2013 WS meeting.

During the 2013 WS meeting, members of the Sector were asked to help identify a suitable replacement eraser; one that could be readily acquired by all the NTEP labs at a reasonable cost so that the NTEP labs could continue testing the permanence of lettering used to mark required information on a device using the same testing medium. An ink eraser called “black pearl” was identified by the WS as a possible replacement and Mr. Jim Truex (NTEP Administrator) agreed to look into the possibility of using the “black pearl” eraser as replacement for the Eberhard Faber ink eraser.

**Conclusion:**

This item has been completed. The Sector was updated on the selection of some suitable replacement erasers for testing permanence of marking. Mr. Truex reported that all appropriate sections of the 2014 edition of NCWM Publication 14 had been amended to reflect the acceptance of the “Papermate Black Pearl” and “Papermate Union #110” as suitable alternatives to the Eberhard Faber ink eraser type #110 in the testing of permanence of marking.

## **NEW ITEMS**

### **4. NIST Handbook 44 Scales Code Paragraph S.5.4 Relationship of Load Cell Verification Interval Value to the Scale Division**

**Source:**

NCWM/NTEP

**Background:**

NTEP has identified two different interpretations of how to apply the formula specified in NIST Handbook 44, Scales Code paragraph S.5.4. Relationship of Load Cell Verification Interval Value to the Scale Division; specifically, to bulleted item (a). The formula determines the suitability of the  $v_{\min}$  value of a load cell in relationship to the value of the scale division (d) for scales without lever systems. The different interpretations occur only when applying the formula to a scale having multiple platforms (Weighing/Load Receiving Elements [W/LRE]) where the output of each W/LRE has its own weight display and is capable of operating as an independent scale in a commercial application.

Consider the number of load cells in each W/LRE of the following example scale and how the formula is to be applied:

Platform	Number of Load Cells
1	4
2	4
3	6

The first interpretation applies the formula to the three W/LREs as a single platform using the total of all load cells (14) for the value of “N” in the formula.

The second interpretation applies the formula to each of the three W/LRE’s individually using only the number of load cells (4, 4 and 6) in the W/LRE for the value of “N” in the formula.

**Recommendation:**

The submitter believes that the second interpretation is correct and suggests the follow actions:

The WS consider completing an NCWM Form 15 and submitting it to the S&T Committees of the Regional Weights and Measures Associations proposing the following “Note” be added below the opening paragraph of Section S.5.4. in the 2015 edition of NIST Handbook 44 as follows:

**NIST Handbook 44 - 2.20. Scales Code Paragraph S.5.4.**

**S.5.4. Relationship of Load Cell Verification Interval Value to the Scale Division.** – *The relationship of the value for the load cell verification scale interval,  $v_{min}$ , to the scale division,  $d$ , for a specific scale installation using National Type Evaluation Program (NTEP) load cells shall comply with the following formulae where  $N$  is the number of load cells in the scale (such as hopper or vehicle scale weighing/load-receiving elements):*

**Note: When the scale installation contains two or more W/LREs where the output of each W/LRE produces its own independent weight display and is thus capable of operating as an independent NTEP certificated scale in a commercial application, the value of “N” should be the number of load cells in each individual W/LRE.**

$$(a) \quad v_{min} \leq \frac{d^*}{\sqrt{N}} \quad \text{for scales without lever systems; and}$$

$$(b) \quad v_{min} \leq \frac{d^*}{\sqrt{N} \times (\text{scale multiple})} \quad \text{for scales with lever systems.}$$

*[\*When the value of the scale division,  $d$ , is different from the verification scale division,  $e$ , for the scale, the value of  $e$  must be used in the formulae above.]*

*This requirement does not apply to complete weighing/load-receiving elements or scales, which satisfy all the following criteria:*

- *the complete weighing/load-receiving element or scale has been evaluated for compliance with T.N.8.1. Temperature under the NTEP;*
- *the complete weighing/load-receiving element or scale has received an NTEP Certificate of Conformance; and*
- *the complete weighing/load-receiving element or scale is equipped with an automatic zero-tracking mechanism which cannot be made inoperative in the normal weighing mode. (A test mode which permits the disabling of the automatic zero-tracking mechanism is permissible, provided the scale cannot function normally while in this mode.*

*[Nonretroactive as of January 1, 1994]*

(Added 1993) (Amended 1996)

Upon NCWM adoption of this recommendation, the Weighing Sector will need to revise *Publication 14*, Digital Electronic Scales, Section 22. *Relationship of  $v_{min}$  to  $d$  and Load Cells*, Section F. *Multiple Load Cell Systems* by adding the same “Note.”

**Conclusion:**

There was no action taken on this item. Due to conflicting NCWM announcements of the Weighing Sector (WS) meeting start time for Tuesday, August 26, not all stakeholders were in attendance when this item was first introduced during the 2014 WS meeting. Consequently, the NCWM agreed to reintroduce this item on the 2015 Weighing Sector Agenda in the interest of fairness to all.

**5. NCWM Publication 14 DES Section B. Certificate of Conformance Parameters, Subsection 8. Weighing Systems, Scales or Weighing/load-receiving elements Greater than 30 000 lb Capacity, Paragraph 8.3.2. Range of Parameters for Modular Scales**

**Source:**

NCWM/NTEP

**Background:**

Current Technical Policy, page DES-8, Section B.8.3.2., of the Digital Electronic Scales (DES) Code states:

"The following range of parameters will be used to establish the sizes and capacities of modular load cell vehicle scales that will be covered on a CC based upon the test of a single scale."

It is believed that as this paragraph is located under Section 8.3. *Modular Load-Cell Vehicle, Livestock, or Railway Track Scales* and there is no other paragraph or section specific to livestock and railway track scales, the paragraph incorrectly limits the parameters stated in "a" thru "j" as applying to only vehicle scales.

**Recommendation:**

The following proposal is suggested for changing the opening paragraph of Section 8.3.2. to identify that Livestock and Railway Track Scales Certificates of Conformance (CC) have the same range of parameters:

**National Type Evaluation Program  
Digital Electronic Scales – Technical Policy**

**B. Certificate of Conformance Parameters**

...

**1. Influence Factors Requirements**

...

**8. Weighing Systems, Scales or Weighing/load-receiving elements Greater than 30 000 lb Capacity**

**8.1.** Additional criteria for vehicle scales, railway track scales, combination vehicle/railway track scales, and other platform scales over 30 000 lb and up to and including 200 000 lb.

**8.2.** ...

**8.3. Modular Load-Cell Vehicle, Livestock, or Railroad Track Scales.**

*Note: These criteria apply if the scale is fully electronic (e.g., load cells comprise the sensors of the weighing/load-receiving element) and is of a modular design.*

**Modular Scale**

A vehicle, livestock, or railroad track scale made up of individual load-receiving elements of like design, which can be joined together to form a larger integral load-receiving element and can be separated at any time without structurally changing the individual load-receiving elements. This definition is to be applied for all new type evaluations and for applications to add new devices to an existing Certificate of Conformance (CC.). *See figure 3.*

(Effective January 2001)

**8.3.1. Modular Scale to be Tested.**

...

**8.3.2. Range of Parameters for Modular Scales.**

The following range of parameters will be used to establish the sizes and capacities of modular load cell ~~vehicle~~ scales that will be covered on a CC based upon the test of a single scale.

- a. Nominal capacities not more than 1.5 times CLC for a two-section scale to 135 % of capacity of the device evaluated. The nominal capacity for the railroad track scale in a modular vehicle/railroad combination will be no greater than the capacity of the device submitted for evaluation.
- b. Platform area not less than 50 % of smallest two-section (four-cell) module incorporated in the device evaluated. Increased lengths for scales with two or more modules are not restricted as long as the width complies with 8.3.2.(e) and the load cells meet the  $v_{min}$  formula (e.g.,  $v_{min} \leq d / \sqrt{n}$ .) Additional modules to increase length must be of the same type as those used in the device submitted for evaluation (e.g., 4-cell, 2-cell, and 0-cell.)
- c. CLCs complying with the minimum CLC rating (e.g., not less than 80 % of the capacity of one cell) but not exceeding twice the capacity of one load cell.<sup>1</sup>
- d. Span(s) between sections which is (are) not more than 20 % greater than the span of the largest two-section, four load-cell module evaluated.
- e. Widths up to 120 % of the width of the platform tested.<sup>2</sup>
- f. Nominal capacity equal to or less than CLC times the number of sections minus one-half.
- g. Platform construction and material similar to that of the device evaluated. See Section 8.e.
- h. Scale division values equal to or greater than the value of the scale division used in the scale that was evaluated.
- i. Number of divisions ( $n_{max}$ ) the number of scale divisions that would exist for scales included in the range of capacities provided it does not exceed the  $n_{max}$  of the load cells and indicator for the installed system.
- j. Module connection type will be limited to the original type evaluated. The manufacturer may choose to submit a special hybrid design including more than one type of module connection. For example, one module can be connected using welded connections and another can be connected using bolted connections. The resulting CC will cover all the types submitted if the evaluation is successful.

Alternatively, the Sector might consider amending the lead-in sentence of paragraph 8.3.2. to read as follows:

The following range of parameters will be used to establish the sizes and capacities of modular load cell vehicle, livestock, or railway track scales that will be covered on a CC based upon the test of a single scale.

**Conclusion:**

The WS agreed with the submitter of this item that all parts of paragraph 8.3.2. in Section B of NCWM Publication 14 DES, including lettered subparts (a) thru (j) are intended to apply to vehicle, livestock, and railroad track scales. To clarify the application of this paragraph, the Sector elected to amend its lead-in sentence (i.e., the submitter's alternative option) as follows:

**8.3.2. Range of Parameters for Modular Scales.**

The following range of parameters will be used to establish the sizes and capacities of modular load cell vehicle, livestock, or railway track scales that will be covered on a CC based upon the test of a single scale.

a. ...

**6. NCWM Publication 14 DES Section 10. Provision for Metrological Sealing of Adjustable Components or Audit Trail**

**Source:**

Maryland Weights and Measures/NTEP Labs

**Background:**

The Maryland NTEP lab was recently performing an evaluation on a device that was subject to the United States/Canada Mutual Acceptance Agreement (MRA) and the manufacturer of the device had designed it to be sealed using a pressure sensitive seal. The design of the sealing mechanism on the device being evaluated complied with existing sealing requirements found in NIST Handbook 44 (i.e., paragraph G-S.8. Provisions for Sealing Electronic Adjustable Components) and current type evaluation criteria in NCWM Publication 14, but did not meet MC's laboratory evaluation manual sections 2.4.4. and 2.4.5. NIST Handbook 44 paragraph G-S.8. Provision for Sealing Electronic Adjustable Components has been copied below for reference:

***G-S.8. Provision for Sealing Electronic Adjustable Components.** – A device shall be designed with provision(s) for applying a security seal that must be broken, or for using other approved means of providing security (e.g., data change audit trail available at the time of inspection), before any change that detrimentally affects the metrological integrity of the device can be made to any electronic mechanism.  
[Nonretroactive as of January 1, 1990]*

A device may be fitted with an automatic or a semi-automatic calibration mechanism. This mechanism shall be incorporated inside the device. After sealing, neither the mechanism nor the calibration process shall facilitate fraud.

(Added 1985) (Amended 1989 and 1993)

**Recommendation:**

Add MC's laboratory evaluation manual requirements found in Sections 2.4.4. and 2.4.5. to NCWM Publication 14 DES Section 10 to better harmonize United States/Canadian type evaluation criteria as it relates to the use of pressure sensitive seals for sealing metrologically significant parameters. The NTEP Weighing Laboratories have discussed and endorsed adding the Canadian requirements. The following changes are suggested for consideration:

**10. Provision for Metrological Sealing of Adjustable Components or Audit Trail**

**Code References: G-S.8.1. and S.1.11.**

The current language in NIST Handbook 44 paragraph G-S.8. states: "A device shall be designed with provision(s) for applying a security seal that must be broken, or for using other approved means of providing security (e.g., data change audit trail available at the time of inspection), before any change that detrimentally affects the metrological integrity of the device can be made to any electronic mechanism."

Thus, for parameters protected by physical means of security, once a physical security seal is applied to the device, it should not be possible to make a metrological change to those parameters without breaking that seal. Likewise, for parameters protected by electronic means of security, it should not be possible to make a metrological change to those parameters without that change being reflected in the audit trail. Since this philosophy addresses provisions for protecting access to any metrological adjustment, the philosophy should be applied consistently to all electronic device types.

Due to the ease of adjusting the accuracy of electronic scales, all scales (except for Class I scales) must provide for a security seal that must be broken or provide an audit trail, before any adjustment that detrimentally affects the performance of the electronic device can be made. Only metrological parameters that can affect the measurement features that have a significant potential for fraud and features or parameters whose range extends beyond that appropriate for device compliance with NIST Handbook 44 or the suitability of equipment, shall be sealed.

For additional information on the proper design and operation of the different forms of audit trail, see *Appendix B for the Requirements for Metrological Audit Trails*.

The judgment of whether or not a method of access to an adjustment represents a "significant potential for fraud" and will normally require sealing for security will be made based upon the application of the *Philosophy for Sealing in Appendix A*.

#### Use of Pressure Sensitive Seals

**Pressure sensitive seals are acceptable under certain conditions. If they cover a hole (e.g., through which a "calibration enable" switch would be activated) the hole must be covered with a suitable rigid plug. The seal must not bridge so as to leave cavities or air pockets under the seal. Cavities and air pockets are weak points that could cause the seal to be easily damaged.**

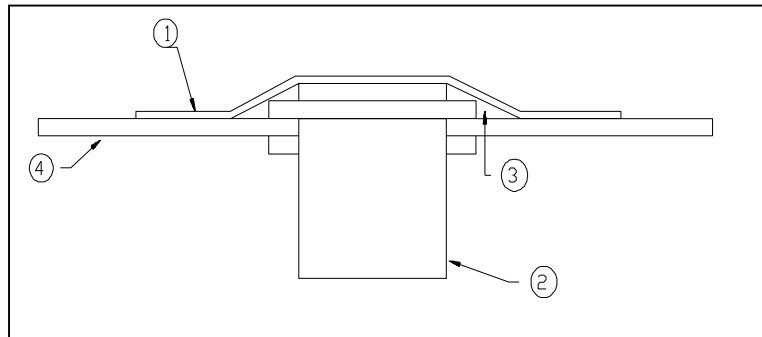

<u>Key</u>
<u>1 Pressure sensitive (paper) seal</u>
<u>2 Keylock</u>
<u>3 Air pocket (void space)</u>
<u>4 Casing</u>

**A pressure sensitive security seal is not suitable in an adverse environment (rain, cold, washdown, etc.).**

#### **Sealing - General**

In addition to satisfying the physical security sealing requirement; the presence of a physical seal shall clearly indicate that the setup or configuration mode (any mode permitting access to any or all sealable parameters based upon the application of the *Philosophy for Sealing in Publication 14*) of the device cannot be accessed without additional actions (e.g., removal of a jumper, pressing a key or switch, etc.) only possible after the removal of the seal.

...

**Discussion/Conclusion:**

This item was withdrawn due to concerns that if the proposal were adopted, it would likely create a conflict between type evaluation and field enforcement. In discussing this item, it was noted that NIST Handbook 44 doesn't restrict the use of pressure sensitive security seals in adverse environments, such as the two environments mentioned as examples in the text of the proposal. Handbook 44 also doesn't limit their use by requiring there be a suitable rigid plug to cover the hole, beneath which exists the switch that enables adjustment to one or more metrological parameters. It was stated that field officials often seek interpretations of NIST Handbook 44 requirements using the NCWM Publication 14 checklists. The concern was that if these new criteria were added to NCWM Publication 14 DES, field officials might begin applying it in the field; when in fact, NIST Handbook 44 does not provide such stringent requirements pertaining to the use of pressure sensitive seals. Some members of the Sector also questioned whether the illustration included in the proposal represented an acceptable or unacceptable example of the use a pressure sensitive seal. MC's representative to the Sector confirmed that the illustration depicted an example of an unacceptable use of the seal and that there was some text missing from the proposal that clarified this to be true.

**7. NCWM Publication 14 ABWS Technical Policy Section E. Automatic Bulk Weighing Systems – NTEP On-Site Evaluation, and ABWS Checklists Paragraph 32**

**Source:**

NCWM/NTEP

**Background:**

Current Technical Policy, Section E, of the Automatic Bulk Weighing Systems (ABWS) Code states:

During laboratory evaluation, the bulk weighing controller is tested under simulated field conditions; therefore, the results of such an evaluation should not be used to determine compliance with all pertinent requirements. Compliance with all requirements shall be determined only when the bulk weighing controller, having successfully passed National Type Evaluation Program laboratory evaluation, is installed and tested under actual field conditions as part of an automatic bulk weighing system.

In addition, Paragraph 32. Performance and Permanence Tests for Automatic Bulk Weighing Systems of the ABWS Code states:

The tests described here, apply to the entire automatic bulk weighing system, (e.g., the bulk weighing scale controller interfaced with the weigh hopper, load cell(s), material handling system, etc.). It is assumed that all components of the automatic bulk weighing scale controller have already been examined and found to comply with applicable National Type Evaluation Program requirements. If the design and performance of the bulk weighing controller is to be determined during the same test, the applicable requirements for automatic bulk weighing systems must be referenced.

The wording implies that a complete evaluation of the weighing controller is not possible without connecting the weighing controller to an actual hopper. After discussing this with the NTEP Labs and a few manufacturers, it was concluded that the weighing control can receive a complete evaluation in the lab with proper simulation.

**Recommendation:**

The following changes to Section E of the ABWS Technical Policy and to Paragraph 32 of the ABWS Checklist are suggested to eliminate the requirement of having to test the weighing controller under field conditions providing a complete simulated test can be conducted during lab evaluation:

**E. Automatic Bulk Weighing Systems - NTEP On-Site Evaluation**

During laboratory evaluation, the bulk weighing controller is tested under simulated field conditions. ~~therefore, the results of such an evaluation should not be used to determine compliance with all pertinent requirements. Compliance with all requirements shall be determined only when the bulk~~



~~weighing controller, having successfully passed National Type Evaluation Program laboratory evaluation, is installed and tested under actual field conditions as part of an automatic bulk weighing system. If the simulation is not capable of simulating all functions and operations of a complete system; the weighing controller is to be installed and all functions or operations not simulated during the laboratory evaluation are to be tested under actual field conditions as part of an automatic bulk weighing system.~~

### 32. Performance and Permanence Tests for Automatic Bulk Weighing Systems

Performance tests are conducted to ensure compliance with the tolerance requirements of NIST Handbook 44 and for systems used to weigh grain with additional requirements of the GIPSA.

The tests described here, apply to the entire automatic bulk weighing system, (e.g., the bulk weighing scale controller interfaced with the weigh hopper, load cell(s), material handling system, etc.) ~~It is assumed that all components of the automatic bulk weighing scale controller have already been examined and found to comply with applicable National Type Evaluation Program requirements.~~ If the design and performance of the bulk weighing controller is to be determined during the same test, the applicable requirements for automatic bulk weighing systems must be referenced.

...

#### Discussion/Conclusion:

There was no action taken on this item. Due to conflicting NCWM announcements of the Weighing Sector (WS) meeting start time for Tuesday, August 26, not all stakeholders were in attendance when this item was first introduced during the 2014 WS meeting. As a result, the NCWM has agreed to reintroduce this item on the 2015 Weighing Sector Agenda in the interest of fairness to all.

### 8. NIST Handbook 44 Scales Code Paragraph S.2.4. Level-Indicating Means and NCWM Publication 14, AWS Section 39 Level-Indicating Means - Portable Automatic Weighing Systems

#### Source:

Maryland NTEP Lab

#### Background:

When performing an NTEP evaluation on a “portable” AWS, Section 39 of the AWS checklist specifies that if the device does not have a level-indicating means then the device must be capable of meeting Scales Code paragraph S.2.4. Level Indication Means. It is assumed that any testing necessary to evaluate whether or not a level is needed on a portable AWS would be conducted in a static mode, although nowhere in Publication 14 is it specified. There is no reference in the AWS Code of NIST Handbook 44 that addresses level indicating means on a portable AWS.

Guidance is needed on what components of an AWS the requirement for level indicating means is intended to be applied. The Maryland lab has encountered AWSs that have had a bubble level built into the load receiving element and others that have had bubble levels built into both the load-receiving element and entire system.

There are also no test procedures in the AWS Checklist of Publication 14 to determine the sensitivity of the level indicating means.

**Recommendation:**

Two recommendations are offered as follows:

1. The Sector consider submitting an NCWM Form 15 proposal to add to the AWS Code of NIST Handbook 44 a paragraph similar to Scales Code paragraph S.2.4., which reads as follows:

**S.2.4. Level-Indicating Means.** – Except for portable wheel-load weighers and portable axle load scales, a portable scale shall be equipped with level indicating means if it's weighing performance is changed by an amount greater than the appropriate acceptance **Error! Bookmark not defined.** tolerance **Error! Bookmark not defined.** when it is tilted up to and including 5 % rise over run in any direction from a level position and rebalanced. The level-indicating means shall be readable without removing any scale parts requiring a tool.

2. The Sector consider adding the same type evaluation procedures that are in NCWM Publication 14, DES Section 56 to AWS Section 39. These procedures would only be applicable to "Portable" systems that are designed to weigh statically. The following was copied from DES Section 56; the first two paragraphs amended to reflect the intended application to AWS Section 39:

**56. Level-Indicating Means - Portable Scales**

**Code Reference: S.2.4.**

~~Portable wheel load weighers and portable axle load scales intended for law enforcement must weigh accurately when placed out of level by 5 %.\*~~

A portable ~~scale~~ **Automatic Weighing System (AWS)** which is intended to be **used in static weighing and** moved must either be equipped with a readily observable level-indicating means (typically a bubble level) or the ~~scale~~ **AWS** must still weigh accurately when placed out-of-level by 5 % (**approximately 3 degrees**). \*Weighing accurately means that the results must be within acceptance tolerance.

The level-indicating means shall be rigidly mounted, located where it will be protected from damage but still be easily read in normal use, mounted so that its reference point for level will not change when pressure is applied to the level-indicator, and sensitive enough to indicate an out-of-tolerance condition that might affect the accuracy of the scale. A bubble level mounted on a swing-out bracket is not adequate. Portable floor scales (generally with capacities of more than 500 lb) shall have the level-indicating means visible without removing any scale parts.

*\*Note: 5 % refers to 5 % rise over run.*

- 56.1.** Scales (other than wheel-load weighers and portable axle-load scales) must meet one of the following conditions:
  - 56.1.1.** The device is equipped with a level indicator as standard equipment? OR  Yes  No  N/A
  - 56.1.2.** The device complies with the provisions of S.2.4. The test procedure is given in "Performance Tests for Digital Counter (Bench) and Computing Scales."  Yes  No  N/A
- 56.2.** If the scale is equipped with a level-indicating means, it must be readily observable without mechanical disassembly that requires the use of tools. A bubble level placed under the scale platform of a portable floor scale mounted on wheels is not practical for the user of the scale.  Yes  No  N/A
- 56.3.** The level-indicating means is rigidly mounted, easily read, protected from damage, and will not change its reference for level.  Yes  No  N/A
- 56.4.** The level-indicating means is sufficiently sensitive:  Yes  No  N/A

- Except for Scales Designated Accuracy Class I, if the scale is equipped with a level-indicating means, the level indicator must be tested to determine whether or not it's sufficiently sensitive.
- Level Sensitivity Tests (if applicable)
- Test Conditions (both analog and digital indicating scales)
- This test is performed at ambient temperature only.
- The device must be leveled using the level indicating means, and adjusted to as close to zero error as possible.

Additional Test Conditions Applicable Only to Digital Indicating Scales:

- The AZT may be activated. It must be set so that the weight value that can be tracked at once does not exceed 0.5 e.
- If the IZSM range of the device does not exceed 20 % of Max, the test will be performed with the IZSM set at the maximum of the range.
- If the IZSM range exceeds 20 % of Max, the test will be performed twice: the first test with the IZSM set to the lowest possible value; the second test with the IZSM set to the maximum of its range.

*NOTE: In the case of a multi-range device, it is 20 % of Max of the lowest range; in the case of a multi-interval device, it is 20 % of max of the first weighing segment.*

- If the device has an "enhance/expanded" resolution feature, perform the test with that feature activated; or use the small weight method to determine errors before rounding.

**56.4.1.** Incline the DUT in one direction (arbitrary referred to as - x) up to the point of limit where the level indicating means still indicates a level condition or at least  $2/1000$  (0.12 degree) whichever is greater.

**56.4.2.** Set the device to zero if necessary; perform an increasing and decreasing load test. If necessary, use the small weight method to find errors before rounding. Record the results.

**56.4.3.** Record the angle with reference to the horizontal.

**56.4.4.** Repeat the test described above for the other three inclinations (+ x, - y, + y) (See the following illustrations).

Position of the Bubble Indicator:

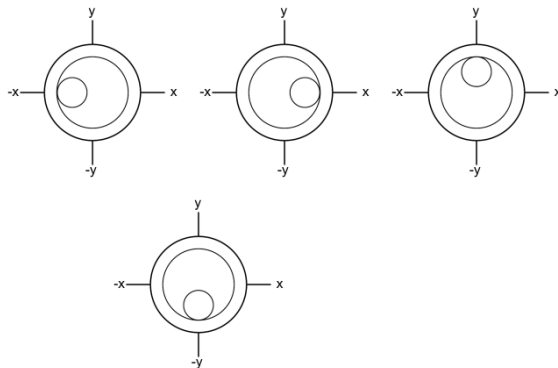

Yes  No  N/A

**56.5.** Wheel-load weighing and axle-load scales must weigh accurately when placed out-of-level by 5 %.\*

**Discussion/Conclusion:**

The Sector agreed that “out-of-level test” procedures need to be added to Publication 14, AWS Section 39. The proposal was modified to reflect AWS paragraph references since it included DES paragraph references. The Sector agreed to the following changes to AWS Section 39.

Amend Section 39 as follows:

**39. Level-Indicating Means - Portable Automatic Weighing Systems**

**Code Reference: G-A.3. and Scales Code S.2.4.**

A portable Automatic Weighing System (AWS) which is intended to be moved **and can be used for static weighing** must either be equipped with a readily observable level-indicating means (typically a bubble level) or the AWS must still weigh accurately when placed out-of-level by 5 % (approximately 3 degrees). Weighing accurately means that the results must be within acceptance tolerance.

The level-indicating means shall be rigidly mounted, located where it will be protected from damage but still be easily read in normal use, mounted so that its reference point for level will not change when pressure is applied to the level-indicator, and sensitive enough to indicate an out-of-tolerance condition that might affect the accuracy of the scale. A bubble level mounted on a swing-out bracket is not adequate. Portable AWS shall have the level-indicating means visible without removing any parts.

39.1. Scales...

39.1.1. The device is equipped with...**OR**  Yes  No  N/A

39.1.2. The device complies with the provisions of NIST Handbook 44 Scales Codes paragraph S.2.4. The **out-of-level** test procedure is given in *NCWM Publication 14 AWS 44.4 43 "Permanence and Performance Tests for ~~Digital~~ Counter (Bench) Scales and (Including) Computing Scales.*"  Yes  No  N/A

39.2 If the scale is equipped with a level-indicating means, it must be readily observable without mechanical disassembly that requires the use of tools. A bubble level placed under the scale platform of a portable floor scale mounted on wheels is not practical for the user of the scale.  Yes  No  N/A

39.3 The level-indicating means is rigidly mounted, easily read, protected from damage, and will not change its reference for level.  Yes  No  N/A

**39.4 The level-indicating means is sufficiently sensitive:**  Yes  No  N/A

- **If the scale is equipped with a level-indicating means, the level indicator must be tested to determine whether or not it's sufficiently sensitive.**
- **Level Sensitivity Tests (if applicable)**
- **Test Conditions (both analog and digital indicating scales)**
  - **This test is performed at ambient temperature only.**
  - **The device must be leveled using the level indicating means, and adjusted to as close to zero error as possible.**

**Additional Test Conditions Applicable Only to Digital Indicating Scales:**

- **The AZT may be activated. It must be set so that the weight value that can be tracked at once does not exceed 0.5 e.**
- **If the IZSM range of the device does not exceed 20 % of Max, the test will be performed with the IZSM set at the maximum of the range.**
- **If the IZSM range exceeds 20 % of Max, the test will be performed twice: the first test with the IZSM set to the lowest**

possible value; the second test with the IZSM set to the maximum of its range.

NOTE: In the case of a multi-range device, it is 20 % of Max of the lowest range; in the case of a multi-interval device, it is 20 % of max of the first weighing segment.

- If the device has an "enhance/expanded" resolution feature, perform the test with that feature activated; or use the small weight method to determine errors before rounding.

39.4.1. Incline the DUT in one direction (arbitrary referred to as - x) up to the point of limit where the level indicating means still indicates a level condition or at least  $2/1000$  (0.12 degree) whichever is greater.

39.4.2. Set the device to zero if necessary; perform an increasing and decreasing load test. If necessary, use the small weight method to find errors before rounding. Record the results.

39.4.3. Record the angle with reference to the horizontal.

39.4.4. Repeat the test described above for the other three inclinations (+ x, - y, + y) (See the following illustrations).  
Position of the Bubble Indicator:

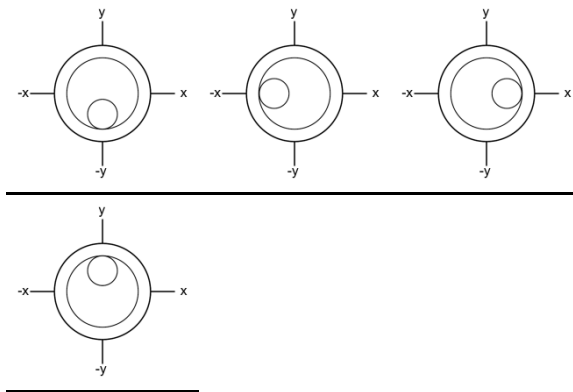

39.5 Automatic weighing systems must weigh accurately when placed out-of-level by 5 %.\*

Yes  No  N/A

\*Note: 5 % refers to 5 % rise over run.

## 9. NCWM Publication 14 DES Section D. Substitution of Load Cells, Load Cells Section 5.

**Source:**  
NCWM/NTEP

**Background:**

Current Load Cell Substitution Policy is outdated and needs to be revised to include the use of new load cell output technology and to make the requirements less open to interpretation.

**Recommendation:**

Replace the current Load Cell Substitution Policy as found in Section D. *Substitution of Load Cell in Scales* on Page DES-11 and Section 5. *Substitution of Metrologically Equivalent Load Cells in Scales* on Page LC-2 of the 2014 edition of NCWM Publication 14, Weighing Devices with the following:

**In a Weighing/Load Receiving Element with a single or multiple load cells installed, the replacement of one or more load cells, from the same or a different manufacturer, is considered a metrologically equivalent replacement provided requirements (1) through (7) below are met.**

- 1. The original and the replacement load cells have a Certificate of Conformance from having been evaluated individually and not as a component in a complete weighing instrument.**
- 2. Have as many or more verification scale intervals ( $n_{max}$ ) as required for the scale's capacity and division size.**
- 3. Have a minimum load cell verification interval ( $v_{min}$ ) that is suitable for the application.**
- 4. Are of the same load cell design as the cell being replaced. Note: load cell design defines the physical design of the load cell. e.g. canister compression, dual ended shear beam, etc...**
- 5. Have a capacity equal to or greater than 85 % of the capacity of the load cells installed during type evaluation testing.**
- 6. Can be placed in the scale without any modification, as defined in Publication 14, Digital Scales Code, Technical Policy, to the basic design of the Load Receiving Element or the load cell mounting assembly. Note: The use of spacers to compensate for differences in load cell height is permitted.**
- 7. Utilize the same output technology (e.g., analog, digital, hydraulic, etc.) as all other load cells in the system or weighing element. Note: For replacement load cells with analog output technology; the same wiring configuration must be maintained as the cells being replaced without adding jumper wires, connecting sense wires to excitation wires, or by removing the sense leads.**

**In a system with multiple load cells, the replacement of ALL load cells in the system with National Type Evaluation Program (NTEP) certified and compatible load cells that have an output technology different than the original load cell is considered a metrologically equivalent replacement provided all requirements in (1) through (6) above are met.**

**Discussion/Conclusion:**

Item 4 of the current load cell substitution policy specifies that load cells to be substituted must be of the same basic type as the cells being replaced. Thus, in order to correctly apply Item 4 of the current load cell substitution policy, one must have knowledge of the different variables that establish load cell type. No explanation of the criteria or factors that were intended to be used to establish same basic type is provided in the policy, nor are any examples of different types of load cells given. Thus, the policy leaves open for interpretation the different factors that establish load cell type.

Much of the discussion by the Sector on this item involved attempts in identifying the criteria or factors that define the “type” (or “design”) of a load cell. There was no consensus reached by the Sector regarding what those factors are or should be. Members of the Sector offered many suggestions of the different factors that they believed might or should define type to include: the method of force introduction, output characteristic, output capacity, impedance, supply voltage, material used in its construction, method of construction, shape, etc. The Sector concluded that the word “design” encompasses many characteristics of a load cell.

The Sector considered whether the load cell substitution policy is intended to apply to the replacement of all the load cells in a scale or just some of the load cells and concluded that the proposed alphabetic list of requirements is intended to apply only to the replacement of one or more load cells in a scale but not full replacement of all the cells.

The Sector agreed to recommend the following changes to the proposal based on comments heard from its members during the discussion of this item:

- Item 4. in the proposed list should read as follows:

**Are of the same basic physical characteristic load cell design as the cell being replaced. Note: load cell design defines the physical design of the load cell (e.g., canister compression, dual ended shear beam, etc.).**

- The following sentence is to replace the sentence in Item 5. of the proposed list:

**Have a capacity that is greater than or not less than 85% of the capacity of the original cell.**

- It was suggested that the following two sentences be added to the end of the proposed list:

**The replacement of a load cell(s) resulting in a combination of analog, digital, or hydraulic load cells in one system is not considered a metrologically equivalent replacement.**

- 1) **All load cells in a multiple load cell system must have the same type of output (e.g., all analog, all digital, or all hydraulic).**

The Sector agreed that additional work on this item is still needed and that it is to remain on next year's WS agenda. Mr. Darrell Flocken (NTEP) agreed to rewrite the proposal taking into account the changes agreed to by the Sector and to make clear the intended application of the alphabetic list of requirements that establish the load cell substitution policy.

## **10. NCWM Publication 14 Load Cells Section L. Procedures - Table 3.**

### **Source:**

NCWM/NTEP

### **Background:**

Tolerances for the evaluation of Class I and II load cells are not mentioned in the load cell section of the 2014 edition of NCWM, Publication 14, Weighing Devices.

### **Recommendation:**

Insert two new tables under the existing Table 3 heading located on page LC-10 of the 2014 edition of NCWM, Publication 14, Weighing Devices. Table 3 currently has a tolerance table for Class III load cells. This proposal would add the two tables shown. (One table for Class I tolerances and the second table for Class II tolerances.)

This publication is available free of charge from: <https://doi.org/10.6028/NIST.SP.1210>

<b>Table 3 Tolerances for Class I Load Cells</b>				
<b>NIST Handbook 44 Reference</b>	<b>Single Cell Requirement</b>		<b>Multiple Cell Requirement</b>	
<b>Load Cell Error Table 6., Class I; T.N.3.2. and T.N.8.1.1.</b>	<b>0.7 Factor Applied</b>		<b>1.0 Factor Applied</b>	
	<b>Load</b>	<b>Tolerance</b>	<b>Load</b>	<b>Tolerance</b>
	0 – 50 000v	0.35v	0 – 50 000v	0.50v
	50 001 – 200 000v	0.70v	50 001 – 200 000v	1.00v
	200 001v +	1.05v	200 001v +	1.50v
<b>Repeatability Error; T.N.5. and T.N.8.1.1.</b>	<b>0.7 Factor Applied</b>		<b>1.0 Factor Applied</b>	
	<b>Load</b>	<b>Tolerance</b>	<b>Load</b>	<b>Tolerance</b>
	0 – 50 000v	0.70v	0 – 50 000v	1.00v
	50 001 – 200 000v	1.40v	50 001 – 200 000v	2.00v
	200 001v +	2.10v	200 001v +	3.00v
<b>Temperature Effect on Minimum Dead Load Output; T.N.8.1.3. and T.N.8.1.1.</b>	<b>0.7 v<sub>min</sub>/5 °C</b>		<b>0.7 v<sub>min</sub>/5 °C</b>	
<b>Effects of Barometric Pressure; T.N.8.2.</b>	<b>Applicable only to specified load cells 1 v<sub>min</sub>/1 kPA</b>		<b>Applicable only to specified load cells 1 v<sub>min</sub>/1 kPA</b>	

<b>Tolerances for Class II Load Cells</b>				
<b>NIST Handbook 44 Reference</b>	<b>Single Cell Requirement</b>		<b>Multiple Cell Requirement</b>	
<b>Load Cell Error Table 6., Class II; T.N.3.2. and T.N.8.1.1.</b>	<b>0.7 Factor Applied</b>		<b>1.0 Factor Applied</b>	
	<b>Load</b>	<b>Tolerance</b>	<b>Load</b>	<b>Tolerance</b>
	0 – 5 000v	0.35v	0 – 5 000v	0.50v
	5 001 – 20 000v	0.70v	5 001 – 20 000v	1.00v
	20 001v +	1.05v	20 001v +	1.50v
<b>Repeatability Error; T.N.5. and T.N.8.1.1.</b>	<b>0.7 Factor Applied</b>		<b>1.0 Factor Applied</b>	
	<b>Load</b>	<b>Tolerance</b>	<b>Load</b>	<b>Tolerance</b>
	0 – 5 000v	0.70v	0 – 5 000v	1.00v
	5 001 – 20 000v	1.40v	5 001 – 20 000v	2.00v
	20 001v +	2.10v	20 001v +	3.00v
<b>Temperature Effect on Minimum Dead Load Output; T.N.8.1.3. and T.N.8.1.1.</b>	<b>0.7 v<sub>min</sub>/5 °C</b>		<b>0.7 v<sub>min</sub>/5 °C</b>	
<b>Effects of Barometric Pressure; T.N.8.2.</b>	<b>Applicable only to specified load cells 1 v<sub>min</sub>/1 kPA</b>		<b>Applicable only to specified load cells 1 v<sub>min</sub>/1 kPA</b>	



**Tolerances for Class III Load Cells** (This current wording already appears beneath Load Cells Table 3 and is shown for positioning of the two new tables being proposed for addition.)

*Submitter's Note: If this proposal is not supported, the WS might consider proposing the removal of all existing references and statements related to Class I and II load cells from NIST Handbook 44 and NCWM Publication 14 under the premises that no CC has been issued for a Class I or II load cell (needs confirmation) and NTEP will release a statement indicating that no CC will be issued for Class I or II load cells.*

**Discussion/Conclusion:**

The WS considered whether there was a need to add the two proposed tables (Tolerances for Class I Load Cells and Tolerances for Class II Load Cells) to NCWM Publication 14 since it was believed that the NTEP labs have never issued any Certificates of Conformance for Class I or Class II load cells. It was noted that the labs may not have the necessary equipment or laboratory qualifications to perform evaluations on Class I or Class II load cells. Members of the Sector agreed to recommend that the two tables be added because it was concluded that there would be no harm in including them in NCWM Publication 14 and that there may come a time in the future when they would be needed.

## 11. VCAP Influence Testing of Weighing/Load Receiving Element with a Capacity $\leq$ 2000 LB

**Source:**

NCWM/NTEP

**Background:**

During a VCAP device type discussion it was noted that a W/LRE with a capacity less than or equal to 2000 lb using a load cell with an NTEP CC is required to undergo influence factor testing during type evaluation. This requirement is determined by reviewing the information in the table titled “Devices to Be Tested for Influence Factors” located in the 2014 edition of NCWM *Publication 14, DES Technology Policy*, paragraph B.1. on page DES-3. The requirement is determined by the fact that there is no distinction between a W/LRE with a capacity less than or equal to 2000 lb using a load cell with an NTEP CC and those using non-NTEP load cells and the fact that W/LRE’s with a capacity less than or equal to 2000 lb can be evaluated in a laboratory environment and will fit inside the labs temperature chamber.

This information supports the requirement that this device type should be included in the list of devices that are subject to the VCAP requirement of ongoing internal auditing by the manufacturer. However, several manufacturers have voiced their concern with this as they believe that a W/LRE with a capacity less than or equal to 2000 lb using a load cell with an NTEP CC should not be included in VCAP. The reason provided is that the load cell is covered by VCAP and it is the only part of the W/LRE that is influenced by temperature changes.

**Recommendation/Discussion:**

Before offering a proposal for consideration, the Weighing Sector should be asked to discuss this subject to provide technical support for or against adding this device type to the VCAP list. The most important but not the only question at this time is:

- Is the load cell the only part/component of the W/LRE that is influenced by changes in temperature?

It would be great if the members of the Weighing Sector could come to a consensus on this matter; because going blindly in one direction or the other could lead to significant changes in current NTEP Policy.

If consensus determines that other parts/components of the W/LRE are influenced by changes in temperature, current NTEP Policy remains intact and the device type will be added to the VCAP device list.

If consensus determines that the load cell is the only part/component of the W/LRE that is influenced by changes in temperature, the table titled “Devices to Be Tested for Influence Factors” will need to be modified to include W/LRE with a capacity less than or equal to 2000 lb using a load cell with an NTEP CC as a separate device and identify them as being exempt from influence factor testing during NTEP evaluations and the device type would not be added to the VCAP list.

1. The list of devices current listed in the 2014 edition of the *NTEP Administration Policy*, paragraph **21.1.3.1. Devices that Must Meet this Requirement Are Limited to the List Below**.
2. The table titled “Devices to Be Tested for Influence Factors,” is shown below for ready reference.

Devices to Be Tested for Influence Factors							
Device Type	Temperature Accuracy <sup>7</sup>	Temperature Zero Drifts	Barometric Pressure	Warm-up Time	Voltage <sup>4</sup>	Power Interruption <sup>5</sup>	Time Dependence
Scales ≤ 2000 lb	X	X	X <sup>1</sup>	X	X	X	X
Scales ≥ 2000 lb	X <sup>2</sup>	X <sup>2</sup>	X <sup>2</sup>	X	X	X	X <sup>2</sup>
ECR's Computers, Bulk-weigher Controllers (without A/D)						X	
Printers						X	
Dials (spring)	X	X					X
Leaver/beam Scales and Pendulum Dials							
Weighing/ Load-Receiving Elements	X	X	X <sup>1</sup>				X
Indicating Element <sup>6</sup>	X	X		X	X	X	
Class II Scales	X	X		X <sup>3</sup>	X	X	X
Load Cells							
Canister-Type	X	X	X <sup>1</sup>				X
Hydraulic	X	X					X
All Others	X	X					X

<sup>1</sup> Testing is limited to some canister load cells.  
<sup>2</sup> Compliance with influence factors requirements will be determined according to existing NTEP policy.  
<sup>3</sup> Test limited to power switch only, not to initial plug-in of the device.  
<sup>4</sup> Voltage test is 130 and 100 VAC and low battery test on DC. *See Section K.60.*  
<sup>5</sup> Power interruption is pulling the plug for 10 seconds. *See Section K.19.*  
<sup>6</sup> Indicating elements processing only digital information do not have to be tested for compliance with the influence factors.  
<sup>7</sup> Compliance with temperature requirements by NTEP is limited to temperatures that are no lower than – 10 °C and no higher than 40 °C.

**Conclusion:**

Mr. Flocken introduced this item to the Sector and reported that the NCWM Board of Directors (BOD) was requesting input from the Sector on a VCAP issue concerning whether or not it is necessary to conduct influence factor testing on a weighing/load-receiving element having a capacity of less than or equal to 2000 lb that uses a load cell with an NTEP CC.

Members of the Sector were asked, by show of hands, to provide a yes or no answer to the following two questions:

1. Is the load cell the only component of a weighing/load receiving element with a capacity less than or equal to 2000 lb affected by temperature?
2. Should VCAP include W/LREs with a capacity less than or equal to 2000 lb and using an NTEP certified load cell?

Results were as follows:

Question 1. *Is the load cell the only component of a weighing/load receiving element with a capacity less than or equal to 2000 lb affected by temperature?*

Answer: Three members indicated “yes,” eight members indicated “no,” and four members “abstained.”

Question 2. *Should VCAP include W/LREs with a capacity less than or equal to 2000 lb and using an NTEP certified load cell?*

Answer: Six members indicated “yes,” seven members indicated “no,” and there were no abstentions.

Mr. Flocken and Mr. Truex agreed to forward the results of the two questions to the NCWM BOD.

## 12. NCWM Publication 14 DES Section 43. Zero-Tracking Mechanism

### Source:

Rice Lake Weighing Systems

### Background:

Clarify how AZT operates in the NET mode.

### Recommendation:

Add procedures in Publication 14 DES Section 43. Zero-Tracking Mechanism for testing AZT in the NET mode. The following changes are suggested:

### 43. Zero-Tracking Mechanism

#### Code Reference: S.2.1.3., S.2.1.3.1., S.2.1.3.2. and S.2.1.3.3

A scale may be equipped with an automatic zero-tracking mechanism (AZT) capability to automatically correct for weight variations near zero within specified limits. To reduce the potential for weighing errors, the AZT may operate only under limited conditions as indicated in the specific type evaluation criteria. Automatic zero-setting (setting the scale to zero after a period of time without the intervention of the operator) beyond the limits of AZT as defined in OIML R76 as an automatic zero-setting mechanism is not permitted in NIST Handbook 44 since there is no limit on the amount of zero adjustment in NIST Handbook 44.

...

For bench, counter, and livestock scales falling under S.2.1.3.1.(a) and S.2.1.3.2.(b) AZT may be operable with the device at a gross load zero, at a net load zero or at a negative net weight indication resulting from a tare weight entry having been made with the scale at zero gross load.

For scales other than bench, counter, and livestock scales falling under S.2.1.3.1.(a) and S.2.1.3.2.(b) ~~and vehicle, axle load and railway track scales,~~ AZT may be operable only at a gross load zero.

Indicate where AZT is operational:

- Gross Zero
- Net Zero
- Negative with Tare

#### Test Procedure for AZT

1. With the scale at zero balance, place a load in excess of the AZT range for the scale (e.g., 10d. Add error weights that are slightly in excess of the specified AZT limit for the device or the AZT setting.)

2. Remove the load (e.g., 10d) but leave the error weights on the scale.
3. Observe whether or not the scale automatically zeroes the error weights.
4. Repeat this procedure by decreasing or increasing the amount of error weights to determine the zeroing range of the AZT.
5. Perform this test in an analogous manner on the negative side of zero to determine the zero range of AZT on the negative side of zero.

**Test Procedure for AZT in the NET Mode**

- 1. With the scale at zero balance, place a load on the scale then TARE this weight.**
- 2. Add a ¼ of a scale division to the scale then observe that the indication stays at the center of zero.**
- 3. Repeat the operation three more time until there is one-hole division that has been zeroed off.**
- 4. Switch to Gross Mode.**
- 5. The indication should display the TARE weight plus 1 division.**

If the device has an AZT capability, record the maximum amount (in scale divisions) that can be zeroed at one time:

- Avoirdupois \_\_\_\_\_ d
- Metric \_\_\_\_\_ d
- Other Units: Specify Unit \_\_\_\_\_ d

...

**Conclusion:** This item was withdrawn at the submitter’s request.

**13. NCWM Publication 14 DES Section D. Substitution of Load Cells, Load Cells Section 5**

**Source:**

Mr. Henry Oppermann, Weights and Measures Consulting

**Background:**

The term “hydraulic compression load cell” has been used on NTEP CCs for two different types of load cells. One type of load cell has a hydraulic load sensor and hydraulically totalizes the output from multiple load cells. The other type has a hydraulic load sensor and a pressure transducer with strain gauges on each load cell to convert the output to a digital signal. The digital output is then totalized. Purchase specifications have stated that scales have “hydraulic load cells.” It is necessary to distinguish between these two types of load cells.

The NTEP CC states that the pressure transducer is considered to be part of the metrological system included in the evaluation of the hybrid load cell. If a “hybrid hydraulic/electronic load cell” in a scale fails, do both the hydraulic component and the electronic component have to be replaced to repair or replace the load cell?

Are the “hybrid hydraulic/electronic load cell” and the “hydraulic load cell” considered to be the same design and, therefore, the same type of load cell?

Under NTEP policy for the substitution of load cells in scales, can all of the “hydraulic load cells” in a scale be replaced with the “hybrid hydraulic/electronic load cells” without requiring a new type evaluation (i.e., does NTEP consider this replacement of load cells to be metrologically equivalent?). Would the proposed change in Item 9 on the Weighing Sector agenda change the interpretation?

The current practice to categorize the two types of load cells as hydraulic load cells is misleading and causes confusion. The two load cell types should be considered different types based upon their design. The load cell with hydraulic

load sensor and hydraulic output should be called a “hydraulic load cell.” The load cell with a hydraulic load sensor and electronic output should be called a “hybrid hydraulic/electronic load cell.” This terminology should be used on NTEP CCs.

The following response was received from Ms. Tina Butcher, NIST OWM, on this subject:

This is in response to your request for a definition of a “hydraulic load cell.”

As you are probably aware, there are references on the internet to the phrase, including sites such as Wikipedia and on web sites of companies that manufacture what are typically described as “hydraulic” load cells. However, I have been unable to find any formal definition that has been reviewed and agreed upon by the legal metrology community.

I did a search of the definitions section of NIST Handbook 44 as well as the Load Cells and Digital Electronic Scales Checklists in NCWM Publication 14 and found no formal definition for “hydraulic load cell.” I also did an electronic search of past summaries of the NTETC Weighing Sector from 1987 to 2013. While there were several references in the summaries to “hydraulic load cells,” I did not find any definition(s) or specific descriptions of these devices. Mr. Rick Harshman, one of our weighing experts, and I also searched through various terminology documents we have in our files, including past Scale Manufacturer Association “Terms and Definitions” and an international Basic and General Vocabulary of Metrology. Additionally, I contacted Mr. John Barton of our office who serves as Secretariat to OIML Recommendation 60, Load Cells. John indicated that previous editions of R 60 have not included any definition for “hydraulic load cells.” In addition, the current edition (now under revision) is being drafted to avoid the inclusion of definitions for specific technologies and designs. This is being purposely done to avoid any interpretation that R 60 will apply to some types of load cells, but not others.

I spoke with Mr. Kevin Chesnutwood a load cell expert in NIST’s Mass and Force Group and shared your questions with him. Kevin indicated that he is not aware of any formal definition for “hydraulic load cell.” With regard to the load cells tested by the Mass and Force Group over the years, load cells referred to as “hydraulic” have most typically channeled hydraulic fluid into a totalizing component (a totalizer) which converts the pressure of the hydraulic fluid into an electronic signal using either strain gauge or pressure technology. This description is closest to the scenario referenced in the second question in your letter “Is a load cell that has a hydraulic input and then uses strain gauges to convert the hydraulic input to an electronic output considered a hydraulic load cell...”

With regard to your specific situation in which you are preparing to place a bid with the [REDATED] in which the solicitation references “hydraulic compression stainless steel load cells,” we don’t have any way of knowing whether their use of the terminology “hydraulic” is referring to the same general understanding that we have of that term. Thus, you may wish to contact [REDATED] to determine what specific type of cell they intend to reference and the reason why this type of cell is specified to get a better understanding of what is needed to meet their requirements. Since you have noted that [REDATED] has allowed for the submission of written questions by July 2, it would seem that your questions about the term as it is used in the solicitation would be best posed to them through that process; particularly since they will be making the final decision on what constitutes a qualified bid.

Although I wasn’t able to locate a formal definition within the legal metrology community documents/materials, I hope the information provided from the search is of help to you.

With Best Regards,

Tina

**Recommendation:**

The Sector identify and develop a complete and unambiguous list of the different types of load cells and include it in *NCWM Publication 14* DES Section D.

When completing an NTEP CC for a hydraulic type load cell that's been evaluated, identify on the CC the type of hydraulic load cell (i.e., hydraulic load cell or hybrid hydraulic/electronic load cell) for which the CC applies.

**Discussion:**

Mr. Oppermann stated that, in his view, NTEP uses the term “hydraulic compression load cell” on CC’s for two different “types” of load cells. He described a number of similarities and differences in the designs of these two load cell “types” pointing out what he considered to be significant differences which, he believed, provided sufficient justification that they be classified as different load cell “types” by NTEP. He reported that the one “type” of hydraulic load cell has both hydraulic input and hydraulic output; a hydraulic totalizer sums the hydraulic output from the different load cells installed in the system. He noted that the forces summed by the hydraulic totalizer are mechanical. The other “type” of hydraulic load cell, which he referred to as a “hybrid hydraulic load cell,” has a pressure transducer with strain gauges on each load cell to convert the output to a digital signal. He indicated that the electronics in these two “types” of load cells must be different and that the two are not interchangeable within a scale. He requested that the Sector develop a list of the different variables that distinguish one type of load cell from another.

Mr. Steve Langford (Cardinal Scale Manufacturing Co.) provided a handout to members of the Sector illustrating the different components of two different versions of multiple hydraulic load cells in a weighing system. A copy of the handout provided by Mr. Langford is included in the “Attachment” section of this report. The handout also outlined some similarities and differences in the two versions. Mr. Langford took an opposing position with regard to Mr. Oppermann’s argument that the load cells illustrated in the two versions should be considered different “types.” He stated that the difference between the two versions illustrated is in the totalizer and not the hydraulic load cells and that the hydraulic load cells in the two example versions illustrated could be interchanged. He questioned why there needed to be a distinction made between the two types of totalizers when the hydraulic load cells in the two examples given are identical. He stated that no such distinction is necessary and that providing such information on the NTEP CC would be a step in the wrong direction. He also voiced opposition to developing a list of the different types of load cells noting that such a list is not needed, nor would NCWM Publication 14 be the place for such a list.

**Conclusion**

The Sector agreed with Mr. Langford’s position and concluded that there is no need to define the different designs of load cells, nor provide a list of the different types of load cells in NCWM Publication 14. Consequently, the Sector agreed not to develop a list of different designs, nor to provide any additional clarification on a CC concerning the type of load cell for which the CC applies.

**NEXT MEETING**

**2015 Suggested Meeting Locations and Dates:**

The following locations are being considered for the next Sector Meeting: Dallas, Texas; Charlotte, North Carolina; Atlanta, Georgia; and Denver, Colorado.

It was agreed that the Sector would meet the week prior to the 2015 Labor Day weekend.

THIS PAGE LEFT INTENTIONALLY BLANK

## ATTENDEES (WEIGHING SECTOR)

### **Cary Ainsworth**

USDA GIPSA  
75 Spring Street, Suite 230  
Atlanta, GA 30303  
P. (404) 562-5426 F. (404) 562-5848  
E. l.cary.ainsworth@usda.gov

### **Tom Buck**

Ohio Department of Agriculture  
8995 East Main Street  
Reynoldsburg, OH 43068  
P. (614) 728-6290  
F. (614) 728-6424  
E. tom.buck@agri.ohio.gov

### **Kevin Chesnutwood**

NIST, Force Group  
100 Bureau Drive, Stop 2600  
Gaithersburg, MD 20899-2600  
P. (301) 975-8107  
E. kevin.chesnutwood@nist.gov

### **Scott Davidson**

Mettler-Toledo, LLC  
1150 Dearborn Drive  
Worthington, OH 43085  
P. (614) 438-4387  
E. scott.davidson@mt.com

### **Robert Feezor**

Scales Consulting and Testing  
35 Stonington Place  
Marietta, GA 30068  
P. (770) 971-7454  
E. rkfeezor@bellsouth.net

### **Darrell Flocken**

National Conference on Weights and Measures  
1135 M Street, Suite 110  
Lincoln, NE 68508  
P. (614) 620-6134  
E. darrell.flocken@ncwm.net

### **Richard Harshman**

NIST, Office of Weights and Measures  
100 Bureau Drive, MS 2600  
Gaithersburg, MD 20899  
P. (301) 975-8107  
E. richard.harshman@nist.gov

### **Scott Henry**

Motorola Solutions, Inc.  
1700 Belle Meade Court  
Lawrenceville, GA 30043  
P. (770) 466-3658  
E. scott.henry@motorolasolutions.com

### **Rainer Holmberg**

Emery Winslow Scale  
73 Cogwheel Lane  
Seymour, CT 06483  
P. (203) 881-9333 x 34  
E. rholmberg@emerywinslow.com

### **Thomas Jones**

Hobart Corporation  
401 W. Market Street  
Troy, OH 45374  
P. (937) 332-2427 F. (937) 332-3007  
E. thomas.jones@hobartcorp.com

### **Stephen Langford**

Cardinal Scale Manufacturing Co.  
203 East Daugherty Street  
Webb City, MO 64870  
P. (417) 673-4631  
E. slangford@cardet.com

### **Paul A. Lewis, Sr.**

Rice Lake Weighing Systems, Inc.  
230 W. Coleman Street  
Rice Lake, WI 54868  
P. (715) 234-6967  
E. plewis@ricelake.com



**L. Edward Luthy**  
Schenck Process, LLC  
108 Wade Drive  
Dover, OH 44622  
P. (440) 241-0194  
E. e.luthy@shcenckprocess.com

**Eric Morabito**  
New York State W&M  
10 B Airline Drive  
Albany, NY 12206  
P. (518) 457-3452  
E. eric.morabito@agriculture.ny.gov

**Henry Oppermann**  
Weights and Measures Consulting  
1300 Peniston Street  
New Orleans, LA 70115  
P. (504) 896-9172  
E. wm-consulting@att.net

**Edward Payne**  
Maryland Department of Agriculture  
50 Harry S. Truman Pkwy  
Annapolis, MD 21401  
P. (410) 841-5790  
E. edward.payne@maryland.gov

**Louis Straub**  
Fairbanks Scales, Inc.  
3056 Irwin Drive S.E.  
Southport, NC 28461  
P. (910) 253-3250  
E. lstraub@fairbanks.com

**Zacharias Tripoulas**  
Maryland Department of Agriculture  
50 Harry S. Truman Pkwy  
Annapolis, MD 21401  
P. (410) 841-5790 F. (410) 841-2765  
E. zacharias.tripoulas@maryland.gov

**Jim Truex**  
National Conference on Weights and Measures  
1135 M Street, Suite 110  
Lincoln, NE 68508  
P. (740) 919-4350  
E. jim.truex@ncwm.net

**Pascal Turgeon**  
Measurement Canada  
151 Tunney's Pasture Drive  
Ottawa, Ontario  
P. (613) 952-0636  
E. pascal.turgeon@ic.gc.ca

**Robert Upright**  
Vishay Transducers  
42 Countryside Road  
North Grafton, MA 01536  
P. (508) 615-1185  
E. rob.upright@vpgsensors.com

**Russ Vires**  
Mettler-Toledo, LLC  
1150 Dearborn Drive  
Worthington, OH 43085  
P. (614) 438-4306  
F. (614) 438-4355  
E. russ.vires@mt.com

**Mike Wedman**  
CA Division of Measurement Standards  
6790 Florin Perkins Road, Suite 100  
Sacramento, CA 95828  
P. (916) 229-3014 F. (916) 229-3026  
E. mike.wedman@cdfa.ca.gov

**Kraig Wooddell**  
Hobart Corporation  
701 Ridge Avenue  
Troy, OH 485374  
P. (937) 332-2238  
E. kraig.wooddell@hobartcorp.com

**Note:**

**The second day of the Weighing Sector meeting was held in conjunction with the NTEP Software Sector whose attendees were also present.**

**ATTACHMENTS**

**Attachment to agenda Item-13: NCWM Publication 14 DES Section D. Substitution of Load Cells, Load Cells Section 5 – Handout provided by Mr. Steve Langford (Cardinal Scale Manufacturing)**

This publication is available free of charge from: <https://doi.org/10.6028/NIST.SP.1210>

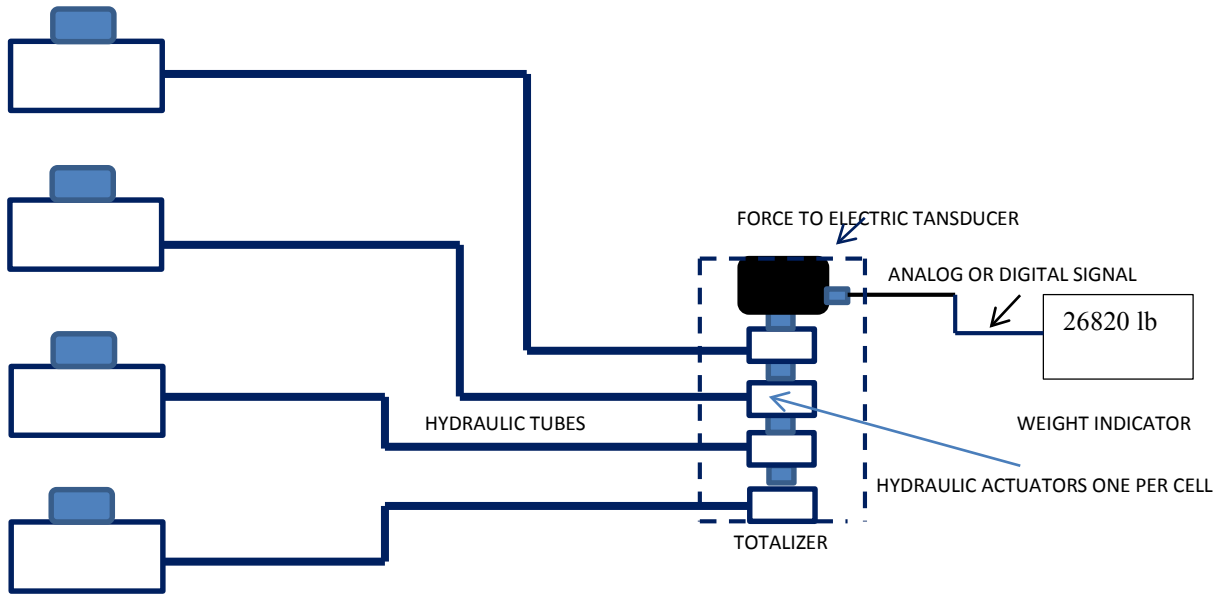

HYDRAULIC LOAD CELLS

**Version A of a Multi-Cell Hydraulic Weighing System**

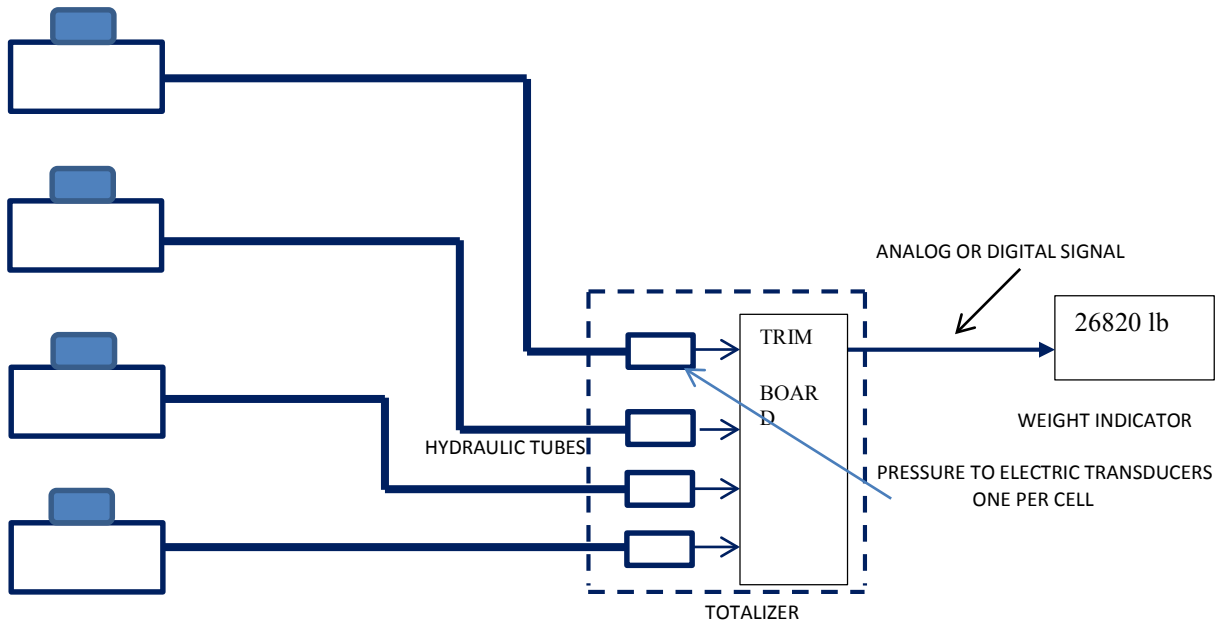

HYDRAULIC LOAD CELLS

### **Version B of a Multi-Cell Hydraulic Weighing System**

- THE DIFFERENCE BETWEEN VERSION A AND VERSION B IS IN THE TOTALIZER, NOT THE HYDRAULIC LOAD CELLS. FOR ALL PRACTICAL PURPOSES THE HYDRAULIC LOAD CELLS IN THE TWO VERSIONS ARE IDENTICAL AND CAN BE INTERCHANGED.
- IN VERSION A, THE PRESSURE SIGNALS FROM EACH HYDRAULIC LOAD CELL ARE CONVERTED TO A FORCE PROPORTIONAL TO THE WEIGHT ON THE HYDRAULIC LOAD CELL AND THOSE FORCES FROM EACH HYDRAULIC LOAD CELL ARE SUMMED MECHANICALLY. THE SUMMED FORCE IS APPLIED TO A FORCE TO ELECTRIC TRANSDUCER OR COMMONLY REFERRED TO AS A LOAD CELL WHERE IT IS CONVERTED TO AN ANALOG VOLTAGE OR DIGITAL OUTPUT.
- IN VERSION B, THE PRESSURE SIGNAL FROM EACH HYDRAULIC LOAD CELL IS CONVERTED TO A PROPORTIONAL ANALOG VOLTAGE IN A PRESSURE TO ELECTRIC TRANSDUCER. THE OUTPUTS OF THE PRESSURE TO ELECTRIC TRANSDUCERS ARE SUMMED IN A CONVENTIONAL LOAD CELL SUMMING CARD OR MULTI-CHANNEL A/D CARD THAT PROVIDES A DIGITAL OUTPUT.
- THE TOTALIZERS IN VERSION A AND VERSION B PERFORM EXACTLY THE SAME FUNCTION BY COMBINING THE PRESSURE OUTPUTS OF THE HYDRAULIC LOAD CELLS INTO A SINGLE ANALOG OR DIGITAL OUTPUT USED BY THE WEIGHT INDICATOR TO DISPLAY THE SCALE WEIGHT.
- QUESTIONS TO THINK ABOUT:
  - 1) In version B, why would you have to replace both the load cell and the pressure to electric transducer should one of them fail? In version A, why would you have to replace both the hydraulic load cell and hydraulic actuator and load cell should one of them fail? Replacing both of these components would be like replacing a lamp along with the light bulb should the light bulb fail. The two components comprise a measuring device but are unaffected by the unique characteristics of each other. The simple answer is you only have to replace the faulty component, not the entire system.
  - 2) Since the hydraulic load cells in Versions A and B are identical, why do we need to make a distinction between the two types of totalizers? The short answer is you don't. Like everything else, each type of totalizer has its own advantages and disadvantages yet they perform the same function. Extending the logic suggested would have you identifying the method of A/D conversion or providing details of the software algorithm used for temperature compensation on the NTEP certificate. NTEP is performance based not design based and adding this information to the NTEP certificate is a step in the wrong direction.
  - 3) Why does a list of the different types of load cells need to be added to NCWM Publication 14? It doesn't. The place for definitions of terms is in NIST Handbook 44 not in NCWM Publication 14. Attempting to identify all types of load cells is not a good idea as John Barton has stated. The people drafting the next version of OIML R60 have gone out of their way NOT to do this

since, as Mr. John Barton stated, they fear that it may be thought that the requirements apply to some types of load cells but not to others. Further still, since this suggested list, if it is indeed needed, is to be placed in NIST Handbook 44, the Weighing Sector is not the arena for accomplishing this. Such an addition must follow the normal course of steps beginning with submission to the regional associations then becoming an item on the Specifications and Tolerances Committee's agenda. This is not a Weighing Sector item.

**Taken from the OIML R60 Work Group 3<sup>rd</sup> Committee Draft April 2014:**

**4. Description of Load Cells**

*A load cell provides an output proportional to a force resulting from applying a load. Load cells may be used as a single transducer or applied together with other load cells in a system where the design allows such application. The term "load cell" Recommendation is not limited to any particular type of technology or design principle. While many technologies are used in the design of load cells, those used in legal metrology applications are commonly designated to provide an output relative to an input stimulus based on an electrical current. Both analog and digital outputs are recognized in load cells within that category. Although strain gauge technology was a primary focus in the development of R60, it is to be understood that load cells that operate using other principles may also be evaluated under this Recommendation. Variations of transducers that operate using alternative basis of input/output may include, but are not limited to: pressure (e.g., hydraulic, pneumatic); vibratory frequency; and magnetic forces.*

*The term load cell may describe an elemental component/module or a somewhat more complex instrument including constituents that perform functions such as signal filtering and analog-to-digital conversion.*

Note the statement that *both analog and digital outputs are recognized in load cells within that category* (load cells used in legal metrology applications). A typical definition for the word analog is *of or relating to a device or process in which data is represented by physical quantities that change continuously*. Using that definition, a hydraulic load cell can be referred to as an analog load cell since its output is indeed represented by physical quantities that change continuously. Why is any addition to that description needed?

Further, the last sentence in section 4 from the OIML R60 Committee Draft states that a load cell can describe a component or module OR a somewhat more complex instrument including constituents that perform functions such as signal filtering and analog-to-digital conversion. The device that we refer to as a hydraulic load cell is a case in point. The hydraulic load cell is used with a totalizer, a constituent component that performs the function of converting the output to an analog or digital signal. In short, the hydraulic load cell, regardless of the technology employed by its totalizer, is a load cell as defined in this OIML R60 Committee Draft. Trying to add the word "hybrid" to the description serves absolutely no purpose engineering or otherwise and only results in adding confusion to what otherwise is a simple definition for a load cell.

THIS PAGE INTENTIONALLY LEFT BLANK

## Appendix G

### Multiple Dimension Measuring Devices Work Group Meeting Summary

October 28-29, 2014  
Reynoldsburg, Ohio

	Page NTEP G/
<b>PRELIMINARIES.....</b>	<b>2</b>
<i>i. Introductions and Welcome of New Work Group Members (R. Kennington).....</i>	<i>2</i>
<i>ii. Reiteration of NTEP Multiple Dimension Measuring Devices (MDMD) Work Group Mission. (J. Truex/D. Flocken) .....</i>	<i>2</i>
<i>iii. Goal of this Meeting. (J. Truex/D. Flocken).....</i>	<i>2</i>
<i>iv. Report – 2014 NCWM Annual Meeting. (J. Truex) .....</i>	<i>2</i>
<i>v. Report – Activity of Measurement Canada. (Pascal Turgeon and Isabelle Tremblay [MC]).....</i>	<i>2</i>
<i>vi. Report – Recent NTEP MDMD Type Evaluation Activity. (J. Truex).....</i>	<i>3</i>
<b>CARRYOVER ITEMS.....</b>	<b>3</b>
<b>1. Review MDMD Meeting Minutes from 2010 meeting. ....</b>	<b>3</b>
<b>2. Review changes to NIST, Handbook 44, MDMD code since last meeting.....</b>	<b>4</b>
<b>3. Review changes to NCWM, Publication 14, MDMD Checklist. ....</b>	<b>4</b>
<b>4. Review changes to Measurement Canada MDMD Terms and Conditions.....</b>	<b>4</b>
<b>5. MDMD and the Mutual Recognition Agreement with Canada. ....</b>	<b>4</b>
<b>NEW ITEMS .....</b>	<b>5</b>
<b>6. Review current position/list of action items. ....</b>	<b>5</b>
<b>7. Review meeting activities and conclusions. ....</b>	<b>6</b>
<b>8. Define next steps.....</b>	<b>6</b>
<b>9. Next meeting. ....</b>	<b>6</b>
<hr/>	
<b>Sub-Appendices</b>	<b>NTEP Page F /</b>
<b>Sub-Appendix A: Meeting Handout of MC Definitions that Apply to Terms and Conditions .....</b>	<b>A1</b>
<b>Sub-Appendix B: Comparison Document of MC and U.S. MDMD Requirements.....</b>	<b>B1</b>
<b>Sub-Appendix C: Illustration of Measurement Canada’s Dimensional Standards.....</b>	<b>C1</b>

## **PRELIMINARIES**

### **i. Introductions and Welcome of New Work Group Members** (*R. Kennington*)

### **ii. Reiteration of NTEP Multiple Dimension Measuring Devices (MDMD) Work Group Mission.** (*J. Truex/D. Flocken*)

#### **Discussion:**

Mr. Jim Truex (NTEP Administrator) and Mr. Darrell Flocken (NTEP Specialist) discussed the mission of the MDMD Work Group (WG) for the benefit of all participants. It was stated there is not much detail included in the NTEP checklist with regard to the testing of MDMDs. The MDMD WG is not considered an NTEP Sector. The mission of the WG is to deal with specific issues concerning MDMDs (i.e., to consider the requirements in NIST Handbook 44 [HB 44], and make sure NTEP has a type evaluation checklist in place to verify compliance with NIST HB 44 and influence factor testing). NTEP has been asked for years to consider encompassing MDMDs under the Measurement Canada (MC)/U.S. Mutual Recognition Arrangement (MRA). At a July 2014 NCWM meeting, Mr. Gilles Vinet (MC) announced Canada wishes to consider including MDMDs under the MRA umbrella with the United States. MC has requested to be lead laboratory. The NCWM Board of Directors is seeking input from MDMD WG with respect to this issue. This would be an annex to the current agreement.

### **iii. Goal of this Meeting.** (*J. Truex/D. Flocken*)

#### **Discussion:**

The challenge is that this group must agree on a common type evaluation checklist. Equipment manufacturers check with MC because they have the most thorough checklist. The NTEP checklist must closely resemble MCs. Getting the technical stuff to agree is the challenge. Requirements between the two countries are similar, but they will never match exactly. We can deal with this. Can we overcome the differences in the checklists? That is the challenge.

### **iv. Report – 2014 NCWM Annual Meeting.** (*J. Truex*)

#### **Discussion/Update:**

The NCWM Annual Meeting was well attended and went well, although there was some controversy concerning alternative fuels. There were no MDMD issues on the agenda. One Specifications and Tolerances (S&T) Committee agenda item involves a company from New Zealand (LoadScan, Ltd.) that manufactures a device, which can measure product in the bed of a truck or trailer. The company is seeking to include new requirements in NIST HB 44 that would address this device.

### **v. Report – Activity of Measurement Canada.** (*Pascal Turgeon and Isabelle Tremblay [MC]*)

**Note:** This agenda item and Carryover Item 4. were combined into a single agenda item.

#### **Discussion/Update:**

The discussion of the combined items was led by Mr. Pascal Turgeon (MC) with additional input provided by Ms. Isabelle Tremblay (MC). Mr. Turgeon distributed three handouts to the WG as follows:

1. A handout of definitions that apply to terms and conditions titled “INTERPRETATION” (Oct 2014). A copy of this document can be found in Appendix A of this report.
2. A spreadsheet showing MC and NTEP checklist references in a side by side format with requirement descriptions. It was stated that this document was last updated in 2012. A copy of this document can be found in Appendix B of this report.
3. A handout titled “Comparison of MDMD Specifications to OIML R 129 and U.S. NIST HB 44 Code 5.58. (January 16, 2012).”

MC's project manager announced in July that MC would like to move forward with the MRA to include MDMDs. The goal is to achieve MRA (i.e., come to agreement on various requirements). OIML R 129 was last revised in 2000. If the WG agrees to something at this meeting that deviates from R 129, it may need to propose changes to R 129 when that document is opened again for revision.

MC is seeing more and more MDMDs being installed in the field and as a result it is receiving more requests for test boxes. A common problem is the weight of the boxes. Max weight of a test box should be 22 lb. New material will be used in the construction of test boxes (Mr. Turgeon passed around a sample of the new material for WG members to see). Different shapes for test objects are also being considered by MC. These will be "known" shapes.

MC may also be adding some new tests. Temperature tests are problematic with regard to full size versus smaller size devices. Some boxes are being wrapped with a black film, which requires different lasers to measure accurately. MC is considering tests for verifying accuracy when shrink wrap is used. If there are differences in MC and U.S. tests, this would not preclude a manufacturer from seeking a certificate from one of the two countries, (e.g., the United States, and not the other). With respect to freight overhanging a pallet, palletized freight is not addressed in NIST Handbook44 or OIML R 129.

**vi. Report – Recent NTEP MDMD Type Evaluation Activity. (J. Truex)**

**Discussion/Update:**

It was reported that the Ohio NTEP laboratory has had nine assignments in 2014, three of which were new manufacturers (or applicants) that had never submitted equipment to the Ohio lab. MC has had approximately three new devices, one of which is from a new applicant (i.e., a manufacturer MC had never worked with prior to 2014).

**CARRYOVER ITEMS**

**1. Review MDMD Meeting Minutes from 2010 meeting.**

**Discussion:**

It was stated that there were two follow-up items from the 2010 meeting as follows:

- (1) Develop a comparison of U.S. and MC type evaluation criteria.
- (2) One discussion topic at the meeting was the test objects used by MC.

With regard to the first item, a comparison spreadsheet was completed by Mr. Justin Rae (MC), which is the second document that was handed out by Mr. Pascal Turgeon in Agenda Item v.; a copy of which can be found in Appendix B of this report. With regard to the second item, Mr. Scott Davidson (Mettler-Toledo, Inc.) had distributed a copy of the test objects specifications. A copy of this document is included in Appendix C of this report.

Mr. Robert Kennington (Quantronix, Inc.), Chairman of the MDMD WG led a review of the 2010 meeting agenda. Items still of importance included on that agenda were identified as follows:

The standards used to test irregular objects – Mr. Joe Morrison (Ohio) pointed out that the Ohio lab uses an "L" shaped object to conduct such tests. MC uses several different shaped objects – refer to Appendix C of the 2014 MDMD meeting agenda to view illustrations of the different shaped objects used by MC.

- a. The rotation of an object into the smallest cuboidal box. Mr. Scott Wigginton (UPS) commented that UPS views this as a very significant issue. He stated that if we cannot get close enough on test requirements, there's no point in having a mutual arrangement because to obtain approval, a device would still need to be submitted to the different laboratories. Mr. Darrell Flocken agreed.



- b. The measurement of palletized objects.

## 2. Review changes to NIST, Handbook 44, MDMD code since last meeting.

### Discussion/Update:

It was reported that there have been two changes to the NIST HB 44 MDMD code since the last WG Meeting (i.e., in 2010) as follows:

1. The title “Other Devices Designed to Make Multiple Measurement Automatically to Determine Volume” was added to paragraph A.2.
2. Paragraph N.1.4.3. Test Objects with Protrusions (shown in the box below) was deleted by adoption of a 2012 proposal. That is, the paragraph did not appear in the MDMD code after 2012.

**N.1.4.3. Test Objects with Protrusions.** – If the device is marked with a minimum protrusion dimension to be measured, a test object with protrusion shall be used to verify the marked limitation during type evaluation.

## 3. Review changes to NCWM Publication 14, MDMD Checklist.

### Discussion/Update:

It was reported that there have been two changes to the MDMD checklist in NCWM Publication 14 since the last WG Meeting (i.e., in 2010) as follows:

1. The title of Section 8 “Accuracy” was changed to “Performance Tests” as the result of a 2010 MDMD WG recommendation.
2. A statement was added to the “Purpose” in Section 10. Influence Factor clarifying procedures to use for influence factor testing.

## 4. Review changes to Measurement Canada MDMD Terms and Conditions.

### Discussion/Update:

Mr. Pascal Turgeon (MC) reported that the handout titled “INTERPRETATION (October 2014),” which was distributed when discussing Agenda Item v., depicted changes to MCs MDMD terms and conditions that were going to be adopted. He noted that blue text in the document provides the rationale for the requirement and is not actually part of the document. Maroon text identifies different terms defined in the Interpretation Section of the document.

## 5. MDMD and the Mutual Recognition Agreement with Canada.

### Source:

NTEP Administrator

### Background/Discussion:

The NCWM Board of Directors has directed NTEP to explore the possibility of expanding the scope of the NCWM/Canada Mutual Recognition Agreement (MRA) to include Multiple Dimension Measuring Devices. Measurement Canada (MC) has agreed to engage in discussions towards expanding the scope of the MRA. Key elements of this consideration are to discuss, develop, and identify 1) the impact to each country; 2) the pros/cons; and 3) a list of the difference in requirements and procedures between the two countries. Once these tasks are completed expansion of the MRA must be evaluated and agreed upon by MC and the NCWM.

### Recommendation:

The WG is asked to identify the different checklist requirements and test procedures, U.S./NTEP vs MC, for MDMDs.

**Conclusion:**

Following the conclusion of the 2010 MDMD Work Group Meeting, Mr. Justin Rae (MC) developed a comparison summary of the requirements in NCWM Publication 14 verses those in the Measurement Canada Manual. The report was reviewed during the 2014 MDMD WG meeting to identify different checklist requirements and test procedures. This activity is ongoing as the WG is currently developing a joint U.S./MC type evaluation checklist.

**NEW ITEMS**

**6. Review current position/list of action items.**

**Source:**

NCWM Board of Directors / NTEP Committee

**Background/Discussion:**

The Work Group has been charged with the task of identifying and recommending changes to the current NTEP and Measurement Canada documents in order to permit the additional of MDMD Devices to be included in the Mutual Recommendation Agreement (MRA) on Type Evaluations. This charge is to include:

1. The comparison of specifications and tolerances between NIST HB 44 and the Measurement Canada Terms and Conditions and document all differences with the intent of addressing these differences in the evaluation checklist or recommend a change to the specification and/or tolerance one or both documents.
2. The comparison of the current NTEP and Measurement Canada Type Evaluation Checklist to identify differences that may be changed with the intent of harmonizing the two documents. An initial comparison has been made by Mr. Justin Rae of Measurement Canada, a copy of this comparison can be found in Appendix B of this agenda.
3. The NCWM Board of Directors and the NTEP Committee, at the suggestion of Measurement Canada, is asking the Work Group to consider recommending the Measurement Canada Evaluation Checklist be the primary document for the evaluation of MDMD Devices.
4. The NCWM Board of Directors and the NTEP Committee, at the suggestion of Measurement Canada, is also asking the Work Group to consider recommending that the Measurement Canada Evaluation Laboratory be identified as the primary laboratory for the evaluation of MDMD Devices.

**Conclusion/Discussion:**

With respect to Charges 1 and 2 of this item, the MDMD WG reviewed the comparison summary list of U.S. and MC requirements developed by MC and identified a number of differences in the type evaluation checklist criteria of the two countries. The WG agreed that changes would be needed to both the NCWM Publication 14 MDMD checklist and the MDMD Code of NIST HB 44 in order to better harmonize U.S./MC requirements. The WG developed a list of changes that would be needed and it is anticipated that this list will be used by the WG to develop future proposals to amend both NIST HB 44 and NCWM Publication 14.

With respect to Charge 3 of this item, the WG agreed to recommend that MC not be the primary document for the evaluation of MDMDs and that each country adopt its own checklist. The WG is currently developing a joint U.S./MC type evaluation checklist and intends to propose in the future, changes to both NIST HB 44 and the MDMD portion of NCWM Publication 14.

With respect to Charge 4 of this item, there was no consensus of the WG on this issue because: 1) it was reported that test data would not be mutually accepted if Canada were to be the primary laboratory; and 2) the time it takes for manufacturers to obtain a certificate through the MC lab due to a backlog of evaluations and custom issues. During the discussion of this charge, it was stated that the MRA is simply an acceptance of test data. Under the arrangement being considered, if MC is made primary lab, it would not accept U.S. type evaluation data but the United States would accept MC's type evaluation data. MC would perform tests that are included in the U.S. type

evaluation checklist even though some of the tests might be exclusive to the United States and not a part of MC's evaluation of a device.

## 7. Review meeting activities and conclusions.

### Discussion:

The WG identified a total of six items that will require proposals to amend NIST HB 44. (*Technical Advisor's note*: A seventh item possibly requiring a proposal to amend NIST HB 44 is the gap in U.S. requirements needed to address multi-interval MDMDs. A small subgroup was formed to develop requirements that address multi-interval MDMDs for NIST HB 44 and NCWM Publication 14 MDMD. Members of the subgroup are as follows: Mr. Darrell Flocken, Mr. Rick Harshman, Mr. Scott Davidson, Mr. Justin Rae, and Mr. Scott Wigginton.

Ms. Isabelle Tremblay (MC) agreed to e-mail MC's current MDMD type evaluation checklist to Mr. Flocken and Mr. Harshman (i.e., the portions of the checklist that are considered fully developed).

## 8. Define next steps.

### Conclusion:

The following next steps were identified:

- Mr. Rick Harshman is to distribute meeting notes to members of the WG at his earliest convenience.
- Mr. Harshman is to prepare a Draft MDMD WG Meeting Report and submit it to Mr. Robert Kennington, WG Chairman, for final approval. Once accepted, the report in final form will be forwarded to Mr. Jim Truex not later than December 12, 2014; that is, in time for submission to the NCWM.
- The WG agreed that recommendations to amend NCWM Publication 14 could not possibly be completed in time to submit them to the NTEP Committee for consideration in the current NCWM cycle. Consequently, it was decided that Mr. Truex will report to the Committee that a joint MC/U.S. type evaluation checklist is being developed by the MDMD WG. Proposals to amend NCWM Publication 14 and NIST HB 44 most likely could be made ready for submission in time to be considered in the 2016 NCWM cycle.
- Mr. Darrell Flocken volunteered to develop a new comparison document (or spreadsheet) that shows comparable U.S./MC paragraph references and provides indication of the WG's decisions to recommend amending NIST HB 44 and NCWM Publication 14. There were a few incorrect paragraph references in the comparison document developed by MC. Mr. Pascal Turgeon agreed to complete the necessary corrections and make Mr. Flocken aware of the changes so that he could include them in the new document that he will be creating. Mr. Flocken hopes to have the comparison document completed and distributed to members of the WG for their review in the March/April 2014 timeframe.

## 9. Next meeting.

The WG tentatively agreed to meet again in May of 2015; that is, shortly after distribution of the new comparison document being prepared by Mr. Darrell Flocken. It was decided that the meeting location would, once again, be Columbus, Ohio.

## Sub-Appendix A: Meeting Handout of MC Definitions that Apply to Terms and Conditions

*NIST Technical Advisor's Note: Shaded portions of the following document are comments that provide the rationale for the requirement and are not part of the actual document. Terms that are italicized in the document are defined in the Interpretation Section (i.e., Section 1 of the document).*

### INTERPRETATION (Oct 2014)

1. The following definitions apply in these terms and conditions.

“multiple-dimension measuring device” means a measuring machine that measures the *dimensions* of an object and determines the *hexahedral dimensions* of that object. (*appareil de mesure multidimensionnelle*)

“dimensions” means length, width and height, measured in units of length. (*dimensions*)

“hexahedron” means a geometric solid or box consisting of six rectangular planes. (*hexaèdre*)

“hexahedral dimensions” in respect of an object, means the *dimensions* of the smallest *hexahedron* within which an object can be contained. (*dimensions hexaédriques*)

“hexahedral volume” in respect of an object, means the volume of the smallest *hexahedron* within which an object can be contained. (*volume hexaédriques*)

- This term is intended to emphasize to a reader that the declared volume is that of the smallest hexahedron and not necessarily that of the object.

“interval” or “d” means the difference between two consecutively indicated values on an axis of a *multiple-dimension measuring device*. (*échelon ou d*)

“multiple-interval measuring range” means a measuring range consisting of two or more partial measuring ranges, each with a different *interval*. (*étendue de mesure à échelons multiples*)

“indicator” means that part of a *multiple-dimension measuring device* that displays measurements and information related to the measurement process. (*indicateur*)

“measuring element” means that part of a *multiple-dimension measuring device* that does not include the *indicator*. (*élément mesureur*)

“registration” means a displayed, printed or recorded representation of any measurement or other information required under these Specifications. (*enregistrement*)

“ready condition,” in respect of a *multiple-dimension measuring device*, means the condition of its being ready to make a measurement. (*état prêt*)

“zero reference,” in respect of a *multiple-dimension measuring device*, means the point from which a measurement is made. (*référence à zéro*)

“dimensional weight” means a numerical value calculated by applying a conversion factor to the *hexahedral dimensions* or *hexahedral volume* of an object for the purpose of determining postage, freight or storage charges. (*poids dimensionnel*)

“tare” means a value that is used to reduce the *dimensions* of an object. (*tare*)

“tare function,” in respect of a *multiple-dimension measuring device*, means a process, mechanism or feature that allows it to utilize *tare*. (*fonction tare*)

“influence factor” means an identified phenomenon or event to which a *multiple-dimension measuring device* is exposed and whose characteristics fall within the operating parameters of the device. (*facteur d'influence*)

“disturbance” means an identified phenomenon or event to which a *multiple-dimension measuring device* is exposed and whose characteristics fall outside the operating parameters of the device. (*perturbation*)

#### APPLICATION

2. These terms and conditions apply to *multiple-dimension measuring devices* that provide *hexahedral dimensions* for use in the calculation of freight, storage or postal charges.

#### DESIGN, COMPOSITION AND CONSTRUCTION

3. A *multiple-dimension measuring device* must be of a design, composition and construction that under normal conditions of use enable the device to measure accurately and do not facilitate the perpetration of fraud.
  - This section is intended to ensure that devices are designed and constructed in such a way that they are able to produce accurate measurements.
  - It is also intended to provide a general means of dealing with problematic device features that may not be addressed elsewhere in these terms and conditions.
4. A *multiple-dimension measuring device* must be designed and constructed in a way that enables inspection procedures and test standards to be applied to the device.
  - the intent of this section is to ensure that MDMDs are physically testable and have the necessary features to facilitate proper inspection of them.
5. A *multiple-dimension measuring device* must be equipped with a feature to indicate the software and any version of the software that it is using.
  - This section is intended to allow quick determination by inspectors, owners, manufacturers, and technicians that a device is or isn't utilizing software that has been identified as problematic.
  - It also facilitates corrective actions when new problems are found with an MDMD's software.
6. The interval of a *multiple-dimension measuring device* must be presented in a decimal format and must be
  - (a) equal to  $1 \times 10^n$ ,  $2 \times 10^n$  or  $5 \times 10^n$ , where the power “n” is a positive or negative whole number or zero; or
  - (b) a binary submultiple of a Canadian unit of measurement set out in Schedule II to the *Weights and Measures Act*.
7. A *multiple-dimension measuring device* that has a multiple-interval measuring range must be configured as follows:
  - (a) the value of the *interval* of every measuring range must be less than the value of the *interval* of the subsequent measuring range ( $d_1 < d_2 < d_3 \dots < d_r$ );

- (b) the maximum length of every measuring range must be equal to the minimum length of the subsequent measuring range (min = min 1, max = max r, max 1 = min 2, etc.);
  - (c) the minimum length of every axis must be equal to the minimum length of the lowest measuring range of the axis; and
  - (d) the maximum length of every axis must be equal to the maximum length of the highest measuring range of the axis.
8. When measuring an object, a *multiple-dimension measuring device* that has a *multiple-interval measuring range* must automatically use the partial measuring range appropriate to the *dimensions* being determined.
- Having the interval size selected automatically makes the user's task easier and contributes to the accurate measurement of packages.
9. A *multiple-dimension measuring device* must be equipped with the following items:
- (a) an indicator or printer that has indicating or recording elements with digits of a design, number and size that permit a clear indication of accurate measurement; and
  - (b) if it is installed with two or more measuring elements connected to a single primary indicator or printer that is separated from one or more of its measuring elements by a distance that does not allow easy inspection, a portable indicator that:
    - (i) is configured to provide the same information as the primary indicator or printer;
    - (ii) provides information that is in exact agreement with the information provided by the primary indicator or printer; and
    - (iii) is readily connectable to all of the measuring elements without affecting the performance of those elements.
- This is to facilitate inspections.
  - It allows inspection of the MDMD at the remote measuring element using the portable indicator.
10. A *multiple-dimension measuring device* that has a means of registration that is connected to two or more *measuring elements* must be equipped with features that:
- (a) automatically identify the *measuring element* that is providing the displayed information; and
  - (b) prevent the activation of any *measuring element* that is not in use.

paragraph a)

- The purpose is to let interested parties know which measuring element is doing the measuring and thus observe the process for any problems.
- It is also for use in complaint investigations or follow up actions by identifying the potential source of a problem.

paragraph b)

- The purpose of paragraph b) is to allow an operator to deactivate a measuring element for any reason deemed necessary.

11. A *multiple-dimension measuring device* that is equipped with an *indicator*, which consists of display elements or segments that may fail individually and produce incorrect information, must have a display test mode that shows all relevant elements and segments of the *indicator*.
- This section is aimed at indicators that consist of individual display elements or segments which can fail or burn out.
  - The failure of individual segments results in an indicator that appears to be operating properly but which is producing erroneous information.
  - For example, an individual element might stay on when it should be off or might be off when it should be on.
  - This section is included to provide an operator or inspector with a quick way to determine if the display segments are operating correctly.
  - Other types of indicators, such as computer monitors, that do not fail in this way are exempt from this section.
12. A *multiple-dimension measuring device* must not provide a measurement registration until the operating temperature necessary for accurate measurement has been attained.
- This section is to ensure accurate measurement.
  - A specific temperature does not have to be stated by the MDMD manufacturer.
13. (1) A *multiple-dimension measuring device* must be equipped with a feature by which the zero reference or ready condition can be established.
- (2) The feature must be interlocked so that its use is prevented during measurement.
- Subsection (1)
- The purpose is to facilitate accurate measurement.
- Subsection (2)
- The purpose is to prevent inadvertent or deliberate measurement errors.
14. (1) A *multiple-dimension measuring device* must automatically maintain a *zero reference* or *ready condition* when no object is in or on the *measuring element* or when a *zero reference* or a *ready condition* has not been established and maintained; must not provide any measurement *registrations*.
- (2) When a *zero reference* or *ready condition* has been established, a *multiple-dimension measuring device* must indicate that fact.
- For most applications and for most operators, it is desirable to have the zero maintained automatically.
  - However, when the zero or ready condition is lost, the MDMD must stop providing measurements.
  - The purpose of Subsection (2) is to allow an operator to clearly see that the equipment is ready for use.
  - This can be done in various ways and will normally be described in the NoA.

15. The measurement *registrations* of a *multiple-dimension measuring device* and any equipment or accessories connected to the device or used in conjunction with it must:
- agree exactly;
  - be clear, accurate and unambiguous; and
  - when provided in printed form, be printed indelibly.
- The purpose of this section is to ensure that all forms of measurement registration provided by a device and all of the equipment used in conjunction with the device, including metrological information transferred or downloaded to a computer, meet the requirements of this section.
  - This requirement doesn't apply to information being used for non-trade or internal company purposes.
  - Dimensional weight is not a measurement registration.
16. The measurement *registration* of a *multiple-dimension measuring device* must:
- be expressed in the same unit of measurement for each of the three axes;
  - be expressed in a single unit of measurement; and
  - include the name or symbol of the unit of measurement.

The objectives of this section are simplicity and clarity.

paragraph (a)

- Having each of the dimensions in the same unit is easier to read.

paragraph (b)

- Prevents the use of mixed units such as cm/mm, feet/inches when quantifying a measurement.
- Examples: 8.7 cm or 87 mm are acceptable whereas 8 cm, 7 mm is not.  
30 inches or 2.5 feet are acceptable whereas 2 feet, 6 inches is not.

17. (1) A *multiple-dimension measuring device* that provides a measurement *registration* of the *hexahedronal volume* of an object must also provide the *hexahedronal dimensions* of the object.
- (2) A *multiple-dimension measuring device* must not express the dimensional weight of an object in any unit of measurement that is set out in Schedule I or II to the *Weights and Measures Act*.

Section 17 (1)

- The reason for this is that the volume is calculated, not measured, and when following up on a complaint or an enquiry, it's the measured dimensions that will be important to the investigation.
- A calculated volume can be the result of more than one set of dimensions.

For example:

$$20 \text{ cm} \times 30 \text{ cm} \times 15 \text{ cm} = 9\,000 \text{ cm}^3$$



$$20 \text{ cm} \times 25 \text{ cm} \times 18 \text{ cm} = 9\,000 \text{ cm}^3$$

Section 17 (2)

- Dimensional weight is a calculated value, not an actual weight and as such may not be accompanied by a unit of measurement on the MDMD indicator.
  - This subsection only applies to the MDMD and not to a printed dimensional weight.
  - The reason is that dimensional weight is not a measurement registration. (see Section 15)
18. A *multiple-dimension measuring device* must not provide a negative measurement *registration* except when it indicates a tare.
- The purpose of this section is to prevent any miscalculations or errors as a result of the inadvertent inclusion of a negative registration in a calculation.
  - Examples of what might be tared; handles on a case, strapping protrusions on a carton, the height of a pallet.
  - Neither this section nor any other section requires that an MDMD must have tare capabilities.
19. (1) The tare function of a *multiple-dimension measuring device* must operate only in a negative direction in relation to the *zero reference* or the *ready condition*.
- (2) A *multiple-dimension measuring device* must clearly indicate when the tare function is in use.
- (3) The value of the tare *interval* must be equal to the value of the *interval* of the respective axis and range in use by the *multiple-dimension measuring device*.
- (4) A *tare* may be less than the minimum length marked on a *multiple-dimension measuring device* for each axis to which the *tare* refers.
- (5) When a *tare* is used, it must be displayed.
- Subsection (1) is to ensure that a tare function can only be used to reduce a length measurement.
  - Subsection (2) is meant to a) allow an operator to see that the tare is active when it is called for as well as to prevent the inadvertent use of the tare function when it isn't called for and b) allow a customer to see that a tare is being used.
  - Subsection (3) is to ensure accurate measurement
  - Subsection (4) allows a tare value to be less than 12 d. (Section 32)
  - Subsection (5) shows the amount of the tare.
20. A *multiple-dimension measuring device* must not provide any measurement *registration*, or must indicate an error message with its measurement *registration*, if the object being measured:
- (a) is smaller than the minimum *dimensions* marked on the device;
  - (b) is larger than the maximum *dimensions* marked on the device plus 9 d; or
  - (c) has *dimensions* that exceed the measurement capability of the device.

- This section requires that an MDMD either not provide measurements or display an error message with the measurements, when the measurements of an object are beyond the marked capabilities of the MDMD.
- Paragraph a) also applies to net measurements that are less than 12 d as a result of the use of a tare.
- Paragraph b): an MDMD can blank at the marked maximum length or any number of additional “d” up to + 9 d. For example, an MDMD that blanks at maximum length + 4 d is acceptable.
- Paragraph c) is to address devices that can’t measure maximum height and maximum width at the same time but that can otherwise measure the maximum height of narrow objects or the maximum width of short objects.

21. (1) A *multiple-dimension measuring device*, its auxiliary equipment or its system must record and provide every customer, either by printed statement or electronic data transmission, the following information in respect of each object measured by the device:

- (a) the identification number or code of the object;
- (b) when it determines the weight of the object for postage, freight, or storage charges, the weight of the object; and
- (c) when it determines the *hexahedral dimensions* of the object for postage, freight, or storage charges:
  - (i) the *hexahedral dimensions* of the object;
  - (ii) the *dimensional weight* of the object if calculated; and
  - (iii) if more than one device or measuring element is installed in the same premises, the device identification.

Subsection 21 (1)

- The information is provided to the customer to assist the customer when he or she has a question or a concern about the measurements or the transaction.
- The information can be provided by either the MDMD itself or some other component in the system.
- This subsection applies in non-retail locations such as a couriers sorting facility.
- This subsection only applies when the packages are to be invoiced by dimensions or weight.
- The subsection does not specify when the information must be provided.
- The information is normally included on the customer’s invoice but could alternatively be sent to the customer in electronic form.

**object identification [paragraph (a)]**

- This is typically being done with a bar code on the package or object and a corresponding number/code provided on the invoice for the package.
- The object identifier must be accompanied by either the weight [paragraph (b)] or the dimensions of the object [paragraph (c)].

**weight of the object [paragraph (b)]**

- When the MDMD or its system includes a scale, this is the actual weight of the object as determined by the scale.
- This terms and conditions does not prohibit manually entered weights; however, when used, they must be used in a manner that ensures accurate measurement. [see paragraph 29(a)].
- When the weight of the object is used to determine the fee for the package, 21 (1) (c) does not apply.

**hexahedral dimensions [paragraph (c)]**

- they are usually presented as L x W x H with a unit of measurement. (Section 16)
- when the hexahedral dimensions of the object are used to determine the fee for the package, the weight of the package does not have to be provided.

**dimensional weight [sub paragraph (c) (ii)]**

- Dimensional weight is a calculated value; it is not a weight.
- It is typically calculated using a formula that divides the hexahedral dimensions or hexahedral volume of an object by a conversion factor.
- The conversion factor and formula are both determined by the courier.
- Dimensional weight is only required when it has been calculated which would probably be most transactions.
- The dimensional weight may have a unit when given on an invoice, but it must be clearly identified as a dimensional weight [sub Section 21(3)]. For example, the letters “dw” or “dim” between the value and the unit.

**Device identification [sub paragraph (c) (iii)]**

- This refers to the MDMD that measured the object.
  - The owner/operator of the MDMDs determines how to identify the MDMDs.
  - This sub-paragraph is to facilitate the investigation of complaints or other issues related to the measurements used in a transaction.
  - It only needs to be provided once on an invoice if all of the packages were measured by the same MDMD.
- (2) A *multiple-dimension measuring device*, its auxiliary equipment or its system must provide every customer who is present at the time of measurement with a printed statement setting out the following information in respect of each object measured by the device:
- (a) the identification number or code of the object; and
  - (b) when it determines the weight of the object for postage, freight or storage charges, the weight of the object;
  - (c) when it determines the *hexahedral dimensions* of the object for postage, freight, or

storage charges:

- (i) the *hexahedral dimensions* of the object;
- (ii) a statement indicating that the *dimensions* are those of the smallest *hexahedron* within which the object can be contained;
- (iii) the *dimensional weight* of the object, if calculated;
- (iv) the conversion factor used to calculate the *dimensional weight* of the object; and
- (v) a statement indicating that the *dimensional weight* of the object is a calculated value obtained by applying a conversion factor to those *dimensions* and is not the actual weight of the object, if the *dimensional weight* is calculated.

Subsection 21 (2)

- The information is provided to the customer to assist the customer when he or she has a question or a concern about the measurements or the transaction.
- The information can be provided by either the MDMD itself or some other component in the system.
- This Subsection applies in situations where the customer is present at the time of measurement such as a retail store.
- The information must be provided to the customer at the time of measurement.
- This subsection only applies when the packages are to be invoiced by hexahedral dimensions or weight.

**smallest hexahedron statement** [sub paragraph (c) (ii)]

- The statement is only required when the hexahedral dimensions are used in the determination of the fee.
- The text of the statement can be different than the text in the subparagraph as long as it conveys the same message.
- The statement can be pre-printed on the receipt or invoice.
- The purpose of the statement is to make clear to a customer that the declared dimensions are of the smallest hexahedron.

**conversion factor** [sub paragraph (c) (iv)]

- This is the factor (for example, 6 000 cm<sup>3</sup> / kg) that is being used to convert the hexahedral dimensions or volume of the measured object into a dimensional weight.
- The factor is only required when the dimensional weight has been calculated.
- It's required for direct sales transactions to ensure that customers who do not have a contract with the courier will know what factor was used in the determination of the fee.

**dimensional weight statement** [sub paragraph (c) (v)]

- The statement is only required when a dimensional weight has been calculated.
  - The text of the statement can be different than the text in the subsection as long as it conveys the same message.
  - The statement can be pre-printed on the receipt or invoice.
  - The purpose of the statement is to make clear to a customer that the dimensional weight is not the actual weight of the object but rather a calculated value.
- (3) The *dimensional weight* of an object must be clearly identified as a *dimensional weight*.

Subsection 21 (3)

A dimensional weight can be confusing because it's often presented with a unit of measurement and sometimes mixed on invoices with actual weights. Because of this, a dimensional weight must be identified as such (i.e., a code, a message, a symbol, etc).

22. (1) If the information required to be provided under Section 21(1) is provided by electronic data transmission, a *multiple-dimension measuring device*, its auxiliary equipment or its system must retain the information for a minimum of 90 days following the date on which the information was initially transmitted by the device, its auxiliary equipment or its system.
- (2) The information required under Section 21(2) (c) (ii), (iv) and (v) may be preprinted on the printed statement.

Subsection 22 (1)

- This does not apply to information that is provided to customers via hard copy invoices or statements.
- This subsection does two things:
  - it ensures that a customer has enough time to review his invoicing information; and
  - provides a customer with access to the information should his or her files be lost or damaged after receipt of the original data transmission.

Subsection 22 (2)

- The statements only need to be provided once on the printed statement.
  - the conversion factor only needs to be provided once on the invoice unless more than one conversion factor is used.
23. The adjustable components of a *multiple-dimension measuring device* must maintain a setting after any adjustment is made.
- The purpose of this section is to ensure dependable and accurate devices.

24. (1) Access to the metrological functions and the adjustable components of a *multiple-dimension measuring device* must be protected by means of readily accessible and observable physical seals or electronic sealing, such as an audit trail, that make apparent any accessing of the metrological functions or adjustable components.
- (2) The information contained in an audit trail must be available and printable on site.
- (3) In this section, “audit trail” means an electronic feature that counts the number of changes made to the calibration or configuration parameters of the device or records the values related to these changes.

Subsection 24 (1)

- Seals are required to restrict access to metrological functions and adjustments that are necessary for the correct operation of an MDMD.
- The seals need to be readily visible so that missing or broken seals will be visible to MDMD users who may then take the necessary steps to deal with the situation.
- The NoA will provide sealing information.
- An audit trail method of security is an acceptable alternative to physical seals, but it must be readily accessible so as to allow easy determination of any changes made to the device.
- An audit trail is subject to the Terms and Conditions for the Approval of Metrological Audit Trails (March 01, 2006).
- Sealing may be a combination of physical seals and an audit trail.

Subsection 24 (2)

- Subsection (2) is to assist an inspector during an inspection.
- The print requirement is to eliminate the need for an inspector to copy information by hand.

25. A *multiple-dimension measuring device* that is equipped with interfaces that allow the connection of auxiliary equipment must be designed so that:

- (a) the metrological functions of the device are not adversely affected by either the operation of the auxiliary equipment or by disturbances or influence factors acting on the auxiliary equipment or interfaces; and
- (b) the interfaces do not allow access to the metrological functions and adjustable components of the device.

Section 25, paragraph (a)

- The cables, connectors and interface ports or ancillary equipment should not be an access route by which interference or disturbances can enter and detrimentally affect the operation and performance of the MDMD or the system as a whole.

Section 25, paragraph (b)

- The interface ports should not be a way to access the metrological functions and adjustments of the

MDMD.

- This requirement does not apply to ports designed for setting up and making adjustments to an MDMD and that would be sealed as per subsection 24 (1).

26. A *multiple-dimension measuring device* must be designed to operate over a temperature range of  $-10\text{ }^{\circ}\text{C}$  to  $+40\text{ }^{\circ}\text{C}$  unless a different temperature range is specified by its manufacturer, in which case it must operate over a temperature range of at least  $30\text{ }^{\circ}\text{C}$ .

This section requires that MDMDs operate satisfactorily over the temperature range that MDMDs are usually used at.

- The  $30\text{ }^{\circ}\text{C}$  reference in this section represents a temperature range and not a specific temperature.
- When expressing metric temperatures, there must be a space between the numeric value [40] and the symbol [ $^{\circ}\text{C}$ ]. For example,  $40\text{ }^{\circ}\text{C}$  not  $40^{\circ}\text{C}$ .

MARKING

27. (1) A *multiple-dimension measuring device* must be clearly and permanently marked with the following information:

- (a) the approval number;
- (b) the manufacturer's name;
- (c) the model designation;
- (d) a serial number;
- (e) the minimum and maximum length for each axis;
- (f) the *interval* for each axis and measuring range;
- (g) the minimum and maximum operating speeds; and
- (h) the temperature range, if other than  $-10\text{ }^{\circ}\text{C}$  to  $+40\text{ }^{\circ}\text{C}$ .

(2) The information must be marked on the *multiple-dimension measuring device* or on a descriptive plate affixed to it that is clearly visible at all times.

- The information is provided for identification purposes and to inform operators of the capabilities of the MDMD.
- The information marked must reflect the approved values and limits.
- The minimum length referred to in 27 (1) (e) is the minimum length that the MDMD can be used to measure (i.e., 12 d).
- Some of this information may not be applicable to some MDMDs. (i.e., multiple measuring ranges, operating speeds)

28. If there are any restrictions, limitations, or conditions on the use of a *multiple-dimension measuring device* or if there are any special applications or uses for it, that information must be clearly and permanently marked

on the device or be posted in close proximity to the device so as to be clearly visible to the operator and any customer who is present at the time of the measurement.

- The purpose of this section is to ensure that operators are aware of any applications and restrictions that apply to the MDMD they are using so that they may take whatever precautions are necessary.
- This section also alerts a customer to these factors and may assist in preventing inaccurate measurements.
- Restrictions, limitations, etc. for an MDMD are found on its NoA.

#### INSTALLATION AND USE

29. A *multiple-dimension measuring device* and any equipment or accessories connected to or used in conjunction with it must be installed, maintained and used in a manner that:

- ensures accurate measurement;
- respects the parameters, restrictions, limitations and conditions of use set out in the notice of approval issued for the device;
- is in accordance with the manufacturer's or importer's instructions;
- does not detrimentally affect the performance of the device; and
- does not facilitate the perpetration of fraud.

- The purpose of this section is to establish conditions that will maximize the occurrence of accurate measurement results.

30. A *multiple-dimension measuring device* must be suitable for its intended use with respect to the elements of its design, composition and construction.

- This section places the responsibility to use a device that has features and capabilities, which are suitable for the measurement task at hand, on the operator of a device.
- Factors such as interval size, capacities, units of measurement, operating speeds, and shape restrictions are usually considered.

31. Every *multiple-dimension measuring device* must be positioned and maintained so that all measurement indications and related information may be easily read, and the measurement of the object observed, by a customer who is present at the time of the measurement.

- The purpose of this section is to ensure that an MDMD is installed so that a customer can see the actual measurement process and the information displayed during the process.
- This allows a customer to see that the measurement was done correctly, or if he has questions about the process, discuss the concern with the operator.
- Customer line of sight is not required for secondary indications or supplemental information displayed away from the normal position of the customer.

32. The minimum net length to be measured by a *multiple-dimension measuring device* is 12 d for the axis and measuring range in use.

- The purpose of this section is to prevent the device from being used to measure an object for which the



limit of error is inappropriately large in relation to a dimension of the object.

- Section 33 tells us that the limit of error is 1 d.
- IF we divide 1 d by a given length, also in terms of d, we can determine the limit of error as a percentage of the length. Some examples;  $1 d \div 10 d = 10 \%$ ,  $1 d \div 5 d = 20 \%$ ,
- The 12 d restriction represents a limit of error of 8.3 %:  $1 d \div 12 d = 8.3 \%$
- The minimum length that can be measured can be different for each axis.
- The minimum length of each measuring range must be equal to or greater than 12 times its “d” value.

For example, range 1 has a d = 5 mm and range 2 has a d = 10 mm. Range 1 must extend to at least 120 mm or 24 d.

#### PERFORMANCE

33. Subject to Section 35, the acceptance and in-service limits of error for *registrations* and tests of a *multiple-dimension measuring device* are  $\pm 1 d$  for the axis and measuring range in use.
- This limit of error applies regardless of the shape, material or position of the object being measured, the type of inspection being done (i.e., approval, initial, control, zone) or the design or type of the device.
  - This limit of error is the same as that of the United States (NIST HB 44) and OIML R 129.
34. A *multiple-dimension measuring device* must perform within the applicable limits of error when it is tested under controlled conditions for the following influence factors:
- (a) any voltage from  $- 15 \%$  to  $+ 10 \%$  of the nominal voltage for devices that use alternating current electricity as a power source;
  - (b) any voltage level at which the device is capable of displaying measurement *registrations* for devices powered by direct current electricity;
  - (c) any temperature within the temperature range marked on the device or, if no range is marked, at any temperature within the range of  $- 10 \text{ }^\circ\text{C}$  to  $+ 40 \text{ }^\circ\text{C}$ ;
  - (d) humidity variations at any level up to 85 % relative humidity, at any temperature within the temperature range specified for the device;
  - (e) ambient light level variations, at any light level intensity from 100 lx to 1500 lx for devices using optical principles of operation;
  - (f) any acoustic interference, at intensity levels of up to 100 db at the nominal centre frequency of the ultrasonic transducers used in the device, for devices using acoustic principles of operation; and
  - (g) any other influence factor that may affect the device's performance.
- The purpose of this section is to provide device manufacturers with a set of conditions under which a device must be able to perform properly.
  - Paragraph g) is included to allow the Approval Services Laboratories to test features that are not covered by the other sections.

- These test conditions are for approval purposes and are not used during routine field inspections.

35. The difference between a measurement *registration* subjected to a disturbance, such as electromagnetic or electrostatic fields, short-time power reduction, electrostatic discharges, electrical bursts or other disturbances, and an undisturbed measurement *registration*, must not exceed 1 d. If the difference exceeds 1 d, the *multiple-dimension measuring device* must:

- (a) blank the *registration* and prevent the transmission, printing and storage of measurement results;
  - (b) provide an error message and prevent the transmission, printing and storage of measurement results;  
or
  - (c) provide a measurement *registration* that is so completely unstable that it cannot be interpreted or transmitted into memory or to a printer as a correct measurement result.
- The purpose of this section is to provide MDMD manufacturers with conditions under which an MDMD must be able to either perform properly or respond in a specified way.
  - These disturbances might be so strong that the MDMD won't be able to operate properly, so other responses are allowed (i.e., blanking, error messages).

#### CHANGES TO THE REGULATIONS

1. The portion of Section 21 of the Weights and Measures Regulations before paragraph (a) is replaced by the following:

21 Before being sold, leased or otherwise disposed of, a weighing machine (other than a weighing device to which the *Terms and conditions Relating to Non-automatic Weighing Devices (1998)* apply) or a measuring machine (other than a multiple-dimension measuring device to which the *Multiple-dimension Measuring Device Terms and conditions apply*) that is of a class, type or design approved under Section 3 of the Act, and any equipment or accessory attached to or used in conjunction with the machine that has or could have an effect on the accuracy of the machine and that was approved under Section 3 of the Act shall be marked with the following information:

2. Subsection 65(2) of the Regulations is replaced by the following:

65 (2) Weighing devices to which the *Terms and conditions Relating to Non-automatic Weighing Devices (1998)* apply and multiple-dimension measuring devices to which the *Multiple-dimension Measuring Device Terms and conditions* apply are exempt from this Part.

THIS PAGE LEFT INTENTIONALLY BLANK

## Sub-Appendix B: Comparison Document of MC and U.S. MDMD Requirements

MC Requirements		
Markings (Section 1)		
MC Manual	MC Spec	
1.1.1	27.1b	name of
1.1.2	27.1c	model n
1.1.3	27.1d	serial nu
1.1.4	27.1a	approva
1.1.5	27.1e	min and
1.1.6	27.1f	interval
1.1.7	27.1g	min and
1.1.8		area for
1.1.9	28	minimum
	27.1h	tempera
LG-1.01	27.1	Letterin
LG-1.02	27.1	Label/P
1.3	5	Softwar
1.6	28	Special
1.6	28	Limitati
	27.2	Location
	none	
1.7	29,30,31	Marking
MC Manual	MC Spec	
3.1.1	9a	registrat
3.1.2	6a	indicatio
3.1.3	6b	binary s
3.2.1	9a, 15b	reading
3.2.2	9a, 15b	digits of
3.2.3	15b	no inter

**Table Continued:**

Indication and Display Features (Section 3)			Design of Indicating or Recording Elements (Section 2)		
MC Manual	MC Spec	Description	Pub. 14	Handbook 44	Description
3.2.4	16a	same unit of measurement of all axes		none	
3.2.5	16b	only one unit of measurement may be used		none	
3.2.6	16c	L,W,H and units marked and are acceptable		none	
3.2.7	15b	separated by decimal point or comma		none	
3.2.8		no fixed zeros		none	
3.2.9	16b	tare and net in same units		none	
3.2.10		rounding followed		none	

NTEP Committee 2015 Final Report  
 Appendix G – 2014 NTEP MDMD Work Group Meeting Summary  
 Sub-Appendix B – Comparison Document of MC and U.S. MDMD Requirements

This publication is available free of charge from: <https://doi.org/10.6028/NIST.SP.1210>

3.2.11		"L, W, H" indicated	none		
3.3.1		Video display - dedicated area for measurement display	none		
3.4.1		Volume displayed correctly (units, significant figures, etc.)	none		
	17	If Volume displayed, dimensions must be provided on demand	2.4	S.1.4.	Only volume indicated - test mode for dimensions
0.3, 0.4 inch division sizes not permitted			2.5.4, 2.5.5	S.1.5.	Indirect Sales: 0.3 and 0.4 inch "d"
no spec for different "d"			2.5.6	S.1.5.2.	"d" in x and y different from z
<b>Recorded Representations (Section 4)</b>			<b>Design of Indicating or Recording Elements (Section 2)</b>		
<b>MC Manual</b>	<b>MC Spec</b>	<b>Description</b>	<b>Pub. 14</b>	<b>Handbook 44</b>	<b>Description</b>
4.1	15c	permanent, legible, same units	2.2	S.1.2.	registrations must be in a digital format
4.2	15b	clearly defined	none		
4.3	15a	same number of decimal places	none		
4.4	16b	unit conversion: proper values	none		
4.5	15b	G, N, T, Total Price, Unit Price in agreement	none		
<b>Annunciators and Symbols (Section 5)</b>			<b>Design of Indicating or Recording Elements (Section 2)</b>		
<b>MC Manual</b>	<b>MC Spec</b>	<b>Description</b>	<b>Pub. 14</b>	<b>Handbook 44</b>	<b>Description</b>
5.1	16c	Appropriate figures, words or symbols	none		
5.2	15b	Metrological annunciators properly defined	none		
5.3	15b	Names, symbols are suitably located	none		
5.4	16b	Unit key must automatically change indicated & printed G,N,T units	none		
5.5		DIM Weight Defined and Correct	none		
<b>Agreement of Registrations (Section 6)</b>			<b>Design of Indicating or Recording Elements (Section 2)</b>		
<b>MC Manual</b>	<b>MC Spec</b>	<b>Description</b>	<b>Pub. 14</b>	<b>Handbook 44</b>	<b>Description</b>
LG-6.01	15a	Digital values of like value - exact agreement	none		
LG-6.02	15b	Suitability of unit conversion	none		

<b>Indicating Zero, Negative and Ready (Section 7)</b>			<b>Design of Zero and Tare (Section 4)</b>		
<b>MC Manual</b>	<b>MC Spec</b>	<b>Description</b>	<b>Pub. 14</b>	<b>Handbook 44</b>	<b>Description</b>
7.1	14(2)	means to indicate zero or ready	2.1, 4.1	S.1.1., S.2.	means to indicate zero or ready
7.2	13(1)	not-ready or off zero on both sides of zero			
7.3	14(1)	automatic maintain zero or ready, or inhibit	2.1, 4.1	S.1.1., S.2.	inhibit measurements if not ready/zero
7.4		no + or - at zero	none		

NTEP Committee 2015 Final Report  
Appendix G – 2014 NTEP MDMD Work Group Meeting Summary  
Sub-Appendix B – Comparison Document of MC and U.S. MDMD Requirements

7.5	18	display negative when gross < tare	2.3	S.1.3.	negative values not displayed unless in tare mode
7.6	18	negative indication cannot be confused	none		
7.7	18	blanking display when under zero	none		
<b>Limits of Indication (Section 8)</b>			<b>Design of Indicating or Recording Elements (Section 2, 11)</b>		
<b>MC Manual</b>	<b>MC Spec</b>	<b>Description</b>	<b>Pub. 14</b>	<b>Handbook 44</b>	<b>Description</b>
LG-8.01	20a, 32	under minimum (12d)	2.7, 11	S.1.7.	under 12 d
LG-8.02	20b, 20c	over maximum (max + 9d)	2.8, 11	S.1.8.	over max + 9d
<b>Zero Activate During Measurement (Section 9)</b>			<b>Design of Zero and Tares (Section 4)</b>		
<b>MC Manual</b>	<b>MC Spec</b>	<b>Description</b>	<b>Pub. 14</b>	<b>Handbook 44</b>	<b>Description</b>
9	13(2)	zero/ready control interlock	4.2	S.2.	zero/ready control interlock
<b>Return to Zero (Section 10)</b>			<b>(Section)</b>		
<b>MC Manual</b>	<b>MC Spec</b>	<b>Description</b>	<b>Pub. 14</b>	<b>Handbook 44</b>	<b>Description</b>
10	13,14	Return to Zero Test	2.1, 4.1		zero/ready condition
<b>Tare (Section 11)</b>			<b>Design of Zero and Tare (Section 4)</b>		
<b>MC Manual</b>	<b>MC Spec</b>	<b>Description</b>	<b>Pub. 14</b>	<b>Handbook 44</b>	<b>Description</b>
11.1.1	19(1)	Tare operates in backward direction only	4.3	S.2.	Tare operates in backward direction onl
11.1.2	15b	Entry of zero tare	none		
11.1.3	19(3)	d tare = d	4.4	S.2.	d tare = d
11.1.4	20	Sum of Tare and Net weight < gross load capacity	none		
11.1.5		NET + Tare = GROSS weight	none		
11.1.6	16b	Tare - selecting units of measurement - accuracy and rounding.	none		
11.1.7		Automatic clearing of tares	none		
11.1.8		Tare non-additive	none		
11.1.9	19(2)	Visual confirmation of Tare entry	4.5	S.2.	clear indication Tare has been taken
LG-11.01		Tare Test	none		
11.2.1		tare entry only at gross load zero	none		
11.2.2		Tare may be retained between transactions	none		

This publication is available free of charge from: <https://doi.org/10.6028/NIST.SP.1210>

Table Continued

Tare (Section 11)			Design of Zero and Tare (Section 4)		
MC Manual	MC Spec	Description	Pub. 14	Handbook 44	Description
11.3.1		tare cancellation if there are means to indicate tare value		none	
11.3.2		Tare may be retained between transactions		none	
Segment Verification (Section 12)			(Section)		
MC Manual	MC Spec	Description	Pub. 14	Handbook 44	Description
12	11	Segment Verification Test		none	
Multiple Measuring Elements (Section 13)			Multiple Measuring Elements (Section)		
MC Manual	MC Spec	Description	Pub. 14	Handbook 44	Description
13.1.1	10b	Prohibit activation of measuring elements not in use	5.1	S.3.	Prohibit activation of measuring elements not in use
13.1.2.	10a	Indicating which measuring element is used	5.2	S.3.	Indicating which measuring element is used
13.1.3		Weighing elements are identified		none	
13.1.4	10a	Recording which weighing element is used		none	
13.1.5		Performing a function on a particular weighing element does not affect other elements		none	
13.1.6	14	Zero or ready must remain active		none	
	9b	Portable indicator			
Multiple Interval (Section 14)			(Section)		
MC Manual	MC Spec	Description	Pub. 14	Handbook 44	Description
14.1.1	7a	$d1 < d2 < d3$		none	
14.1.2		Gross = Net + Tare		none	
14.1.3		Gross = Net + Tare: exact agreement		none	
14.1.4		Tare: Rounding rules		none	
14.1.5	33	Tolerance function of range		none	
14.1.6	33	Keyboard or Platter Tare: meets tolerance for net loads		none	
	7b, c, d	Capacity of ranges		none	
Direct Sale (Section 15)			(Section)		
MC Manual	MC Spec	Description	Pub. 14	Handbook 44	Description
15	22, 31	Information as required by Spec 22		none	
Non-Metrological Functions (Section 16)			(Section)		
MC Manual	MC Spec	Description	Pub. 14	Handbook 44	Description
16	29	Non-metrological functions do not cause errors, perpetration of fraud		none	

This publication is available free of charge from: <https://doi.org/10.6028/NIST.SP.1210>

NTEP Committee 2015 Final Report  
Appendix G – 2014 NTEP MDMD Work Group Meeting Summary  
Sub-Appendix B – Comparison Document of MC and U.S. MDMD Requirements

Software Version Test (Section 17)			Markings (Section 1)		
MC Manual	MC Spec	Description	Pub. 14	Handbook 44	Description
17	5	Software Identification test	1.4	G-S.1.	Software markings
Performance Tests (Part 3)			Performance (Sections 7, 8, 9, 10)		
MC Manual	MC Spec	Description	Pub. 14	Handbook 44	Description
3.01	36	Short Time Power Reduction (not performed)		none	
3.02	35a,b	Power Voltage	9	T.5.2.	Power Voltage
3.03	36	Electrical Burst Test (not performed)		none	
3.04	36	Electrostatic Discharge (not performed)		none	
3.05	36	EM Susceptibility (not performed)		none	
3.06	3, 33	Warm Up	7	S.1.9.	Warm Up
3.07	3, 33	Conveyor Belt Seam		none	
3.08	3, 33	Measurement Speed Test		none	
3.09	7,8	Interval of “d”			
3.10	26,33, 35c	Temperature range	10	T.5.1.	Influence Factor
3.11	35d	Damp Heat (not performed)		none	
3.12	3, 33	Eccentricity		none	
3.13	3, 33	Drag Test		none	
3.14	33	Repeatability	8		Accuracy
3.15	3, 33	Minimum Spacing		none	
3.15.5	3, 33	Touching		none	
3.16	3, 33	Variable Orientation		none	
3.17	3, 33	Variable Object Shape		none	
3.18	3, 33	Variable Surface (only for palletized)		none	
3.19	3, 33	Protrusions (not performed)		none	
3.20	3, 33	Sensor/Emitter Obstruction		none	
3.21	35e	Radiated Light (not performed)		none	
3.22	35f	Acoustic Interference (not performed)		none	

**Notes:**

- 1) Table S.1.6 (NIST Handbook 44) and Spec. 21, 22 (MC) contain marking requirements that are not always part of an approval evaluation, as this info is sometime instead to be provided by the billing system used in conjunction with the device.
- 2) Sealing requirements were not included in this comparison.



THIS PAGE INTENTIONALLY LEFT BLANK

## Sub-Appendix C: Illustration of Measurement Canada’s Dimensional Standards

### Dimensional Standards

**Materials:**  
NYLATRON NSM

**Dimensions:**

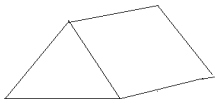

**Triangular Prism 1 (L5m-A):**  
20 cm each side × 60 cm length

**Triangular Prism 2 (L5m-B):**  
40 cm each side × 40 cm length

**Cylinder 1 (L5m-C):**  
Ø 15 cm × 60 cm length

**Cylinder 2 (L5m-D):**  
Ø 40 cm × 40 cm length

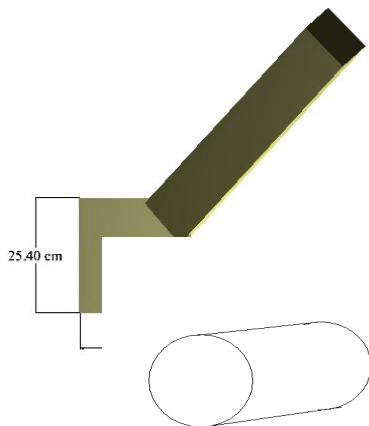

**Irreg 1 (L5m-E):**  
Cube side = 25.4 cm  
Extension = 90 cm total length from the corner  
of the box to the extremity of the extension (part  
of which will be inserted inside the cube) x 12  
cm x 12 cm

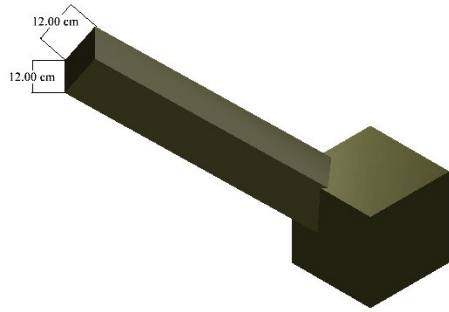

**Irreg 2 (L5m-F):**

Cube side = 40 cm

Extension = 130 cm total length from the corner of the box to the extremity of the extension (part of which will be inserted in the cube) x 18 cm x 18 cm

**Construction:**

Fabrication tolerances for each box are as follows:

linear tolerance:  $\pm 0.5$  mm ( $\pm 0.02$  in)

angular tolerance:  $\pm 0.5$  mm ( $\pm 0.02$  in)

Thickness of the material: 9.525 mm ( $3/8$  in) to 12.7 mm ( $1/2$  in), depending on the design for the construction, #6 and #8 stainless steel woods screws.

The surfaces shall be perfectly parallel and perpendicular to within the above stated tolerances.

Irreg 1 and Irreg 2 must be constructed such that they are completely stable when placed in the position indicated in the drawings above.

Maximum weight of each standard: 15 kg.

All standards to be engraved with their name.

All surfaces shall be smooth, identified with an engraved number and have their nominal dimensions engraved in millimetres.

## Report of the Nominating Committee

Mr. John Gaccione, Committee Chair  
Westchester County, New York

### 800 INTRODUCTION

The Nominating Committee (hereinafter referred to as the “Committee”) met during the Interim Meeting of the National Conference on Weights and Measures (NCWM) Interim Meeting, January 18 - 21, 2015, in Daytona Beach, Florida. At that time, the Committee nominated persons for the various available Board of Director positions for the 101<sup>st</sup> NCWM. The following report reflects the decisions of the NCWM membership.

Table A identifies the agenda items by reference key, title of item, page number and the appendices by appendix designations, and Table B reflects the Voting Results.

**Table A  
Table of Contents**

Reference Key	Title of Item	NOM Page
<b>800</b>	<b>INTRODUCTION .....</b>	<b>1</b>
<b>810</b>	<b>NOMINATIONS.....</b>	<b>3</b>
810-1	V Officer Nominations.....	3

**Table B  
Voting Results**

<i>Reference Key Number</i>	<i>House of State Representatives</i>		<i>House of Delegates</i>		<i>Results</i>
	<i>Yeas</i>	<i>Nays</i>	<i>Yeas</i>	<i>Nays</i>	
To Elect the Slate of Officers as presented in the Report	Voice Vote				Adopted

THIS PAGE INTENTIONALLY LEFT BLANK

---

**Details of All Items**  
*(In order by Reference Key)*

---

## 810 NOMINATIONS

(This item was adopted by unanimous vote of the 100<sup>th</sup> National Conference on Weights and Measures.)

### 810-1 V Officer Nominations

**Source:**

Nominating Committee

**Purpose:**

Election of NCWM officers

**Item Under Consideration:**

The following slate of officers was selected by unanimous vote of the Committee:

**Chairman-Elect:**

Ms. Kristin Macey, California Division of Measurement Standards

**Board of Directors Active Director – Central: (5 years)**

Mr. Craig Van Buren, Michigan Department of Agriculture and Rural Development

**Treasurer: (1 year)**

Mr. Raymond Johnson, New Mexico Department of Agriculture

**Background/Discussion:**

The Nominating Committee met during the 2015 Interim Meeting at the Hilton Daytona Beach Oceanfront Resort in Daytona Beach, Florida, at which time the Committee nominated the persons listed above to be officers of the 101<sup>st</sup> National Conference on Weights and Measures. In the selection of nominees from the active and associate membership, consideration was given to professional experience, qualifications of individuals, conference attendance and participation, and other factors considered to be important.

---

Mr. John Gaccione, Westchester County, New York | Committee Chair  
Mr. Stephen Benjamin, North Carolina | Member  
Ms. Judith Cardin, Wisconsin | Member  
Mr. Charles Carroll, Massachusetts | Member  
Mr. Kurt Floren, Los Angeles County, California | Member  
Mr. Joe Gomez, New Mexico | Member  
Mr. Randy Jennings, Tennessee | Member

### Nominating Committee

THIS PAGE INTENTIONALLY LEFT BLANK

# 100<sup>th</sup> Annual Meeting Attendees

**Sprague Ackley**

Honeywell  
16201 25th Avenue W  
Lynnwood, WA 98037  
**Phone:** (425) 501-8995  
**E-mail:** [hsprague.ackley@honeywell.com](mailto:hsprague.ackley@honeywell.com)

**Sonia Adams**

ASTM International  
100 Barr Harbor Drive  
West Conshohocken, PA 19428  
**Phone:** (610) 832-9612  
**E-mail:** [sadams@astm.org](mailto:sadams@astm.org)

**David Aguayo**

San Luis Obispo County, Dept. of Agriculture and  
Weights and Measures  
2156 Sierra Way  
Suite A  
San Luis Obispo, CA 93401  
**Phone:** (805) 781-5922  
**E-mail:** [daguayo@co.slo.ca.us](mailto:daguayo@co.slo.ca.us)

**Cary Ainsworth**

USDA, GIPSA  
75 Spring Street  
Suite 230  
Atlanta, GA 30303-3309  
**Phone:** (404) 562-5426  
**E-mail:** [l.cary.ainsworth@usda.gov](mailto:l.cary.ainsworth@usda.gov)

**John Albert**

Missouri Department of Agriculture  
1616 Missouri Boulevard  
P.O. Box 630  
Jefferson City, MO 65102  
**Phone:** (573) 751-7062  
**E-mail:** [John.Albert@mda.mo.gov](mailto:John.Albert@mda.mo.gov)

**Mahesh Albuquerque**

CDLE-Oil and Public Safety  
633 17th Street  
Suite 500  
Denver, CO 80202  
**Phone:** (303) 318-8502  
**E-mail:** [mahesh.albuquerque@state.co.us](mailto:mahesh.albuquerque@state.co.us)

**Holly Alfano**

Independent Lubricant Manufacturers Assn.  
400 N. Columbus Street  
Suite 201  
Alexandria, VA 22314  
**Phone:** (703) 684-5574  
**E-mail:** [halfano@ilma.org](mailto:halfano@ilma.org)

**Jim Allan**

Solano Co Agriculture Weights and Measures  
501 Texas Street, 2nd Floor  
Fairfield, CA 94533  
**Phone:** (209) 470-3677  
**E-mail:** [jdallan@solanocounty.com](mailto:jdallan@solanocounty.com)

**Ross Andersen**

25 Moon Drive  
Albany, NY 12205  
**Phone:** (518) 869-7334  
**E-mail:** [rjandersen12@gmail.com](mailto:rjandersen12@gmail.com)

**Paige Anderson**

National Association of Convenience Stores  
1600 Duke Street  
Alexandria, VA 22314  
**Phone:** (703) 518-4221  
**E-mail:** [panderson@nacsonline.com](mailto:panderson@nacsonline.com)

**Michael Bannon**

Bucks County Consumer Protection  
Weights and Measures  
50 North Main Street  
Doylestown, PA 18901  
**Phone:** (215) 348-7442  
**E-mail:** [mdbannon@co.bucks.pa.us](mailto:mdbannon@co.bucks.pa.us)

**Brett Barry**

Clean Energy  
4675 MacArthur Court  
Suite 800  
Newport Beach, CA 92660  
**Phone:** (562) 522-7427  
**E-mail:** [bbarry@cleanenergyfuels.com](mailto:bbarry@cleanenergyfuels.com)



**John Barton**

NIST, Office of Weights and Measures  
100 Bureau Drive, MS 2600  
Gaithersburg, MD 20899-2600  
**Phone:** (301) 975-4002  
**E-mail:** john.barton@nist.gov

**Steve Beitzel**

Systems Associates, Inc.  
1932 Industrial Drive  
Libertyville, IL 60048  
**Phone:** (847) 367-6650  
**E-mail:** sjbeitzel@systemsassoc.com

**Sam Bell**

Echols Oil Company, Inc.  
P. O. Box 1477  
Greenville, SC 29602  
**Phone:** (864) 233-6205  
**E-mail:** info@scpma.com

**Stephen Benjamin**

North Carolina Department of Agriculture  
1050 Mail Service Center  
Raleigh, NC 27699-1050  
**Phone:** (919) 707-3225  
**E-mail:** steve.benjamin@ncagr.gov

**Ann Boeckman**

Kraft Food Group, Inc.  
Three Lakes Drive  
Northfield, IL 60093  
**Phone:** (847) 646-2862  
**E-mail:** ann.boeckman@kraftfoods.com

**Adam Bolain**

Heinz North America  
P.O. Box 57  
Pittsburgh, PA 15230-0057  
**Phone:** (724) 778-5640  
**E-mail:** adam.bolain@us.hjheinz.com

**Ben Boroughs**

North American Millers' Association  
600 Maryland Avenue SW  
Washington, DC 20024  
**Phone:** (202) 484-2200  
**E-mail:** bboroughs@namamillers.org

**Chris Bradley**

Seraphin Test Measure  
30 Indel Avenue  
P.O. Box 227  
Rancocas, NJ 08073  
**Phone:** (609) 267-0922  
**E-mail:** cbradley@seraphinusa.com

**Rex Brown**

Petroleum Equipment Institute  
P.O. Box 2380  
Tulsa, OK 74101  
**Phone:** (918) 236-3961  
**E-mail:** jrbrown@pei.org

**Norm Brucker**

Retired  
1665 Bonaire Path West  
Rosemount, MN 55068  
**Phone:** (651) 423-3241  
**E-mail:** sharnoma@frontiernet.net

**Jerry Buendel**

Washington State Department of Agriculture  
1111 Washington Street  
P.O. Box 42560  
Olympia, WA 98504-2560  
**Phone:** (360) 902-1856  
**E-mail:** jbuendel@agr.wa.gov

**Luciano Burtini**

Measurement Canada  
2008 Matera Avenue  
Kelowna, BC V1V 1W9  
**Phone:** (250)862-6557  
**E-mail:** luciano.burtini@ic.gc.ca

**Tina Butcher**

NIST, Office of Weights and Measures  
100 Bureau Drive, MS 2600  
Gaithersburg, MD 20899-2600  
**Phone:** (301) 975-2196  
**E-mail:** tina.butcher@nist.gov

**Marc Buttler**

Emerson Process Management - Micro Motion  
7070 Winchester Circle  
Boulder, CO 80301  
**Phone:** (303) 581-1970  
**E-mail:** marc.buttler@emerson.com

**David Calix**

NCR Corporation  
1510 North Walton Boulevard  
Bentonville, AR 72712  
**Phone:** (479) 372-8407  
**E-mail:** david.calix1976@gmail.com

**Bill Callaway**

Crompco  
1003 West Share Drive  
Yardley, PA 19067  
**Phone:** (610) 256-7185  
**E-mail:** bill.callaway@crompco.com

**Bill Cannella**

Chevron  
 100 Chevron Way  
 Richmond, CA 94801  
**Phone:** (510) 242-2829  
**E-mail:** [bijc@chevron.com](mailto:bijc@chevron.com)

**Loretta Carey**

U.S. Food and Drug Administration  
 5100 Paint Branch Parkway  
 College Park, MD 20740  
**Phone:** (240) 402-1799  
**E-mail:** [loretta.carey@fda.hhs.gov](mailto:loretta.carey@fda.hhs.gov)

**Stacy Carlsen**

Marin County Department of Agriculture  
 Weights and Measures  
 1682 Novato Boulevard  
 Suite 150-A  
 Novato, CA 94947-7021  
**Phone:** 415-473-6700  
**E-mail:** [scarlsen@marincounty.org](mailto:scarlsen@marincounty.org)

**Charlie Carroll**

Massachusetts Division of Standards  
 One Ashburton Place  
 Room 1115  
 Boston, MA 02108  
**Phone:** (617) 727-3480  
**E-mail:** [Charles.Carroll@state.ma.us](mailto:Charles.Carroll@state.ma.us)

**Jimmy Cassidy**

City of Cambridge Weights and Measures Department  
 831 Massachusetts Avenue  
 Cambridge, MA 02139  
**Phone:** (617) 349-6133  
**E-mail:** [jcassidy@cambridgema.gov](mailto:jcassidy@cambridgema.gov)

**Rick Chapman**

Innospec Fuel Specialties  
 200 Executive Drive  
 Newark, DE 19702  
**Phone:** (630) 386-3406  
**E-mail:** [rick.chapman@innospecinc.com](mailto:rick.chapman@innospecinc.com)

**Kevin Chesnutwood**

NIST, Quantum Measurement Division  
 Engineering Mechanics  
 100 Bureau Drive, Stop 8222  
 Gaithersburg, MD 20899-8222  
**Phone:** (301) 975-6624  
**E-mail:** [kevin.chesnutwood@nist.gov](mailto:kevin.chesnutwood@nist.gov)

**Tim Chesser**

Arkansas Bureau of Standards  
 4608 West 61<sup>st</sup> Street  
 Little Rock, AR 72209  
**Phone:** (501) 570-1159  
**E-mail:** [tim.chesser@aspb.ar.gov](mailto:tim.chesser@aspb.ar.gov)

**Adam Choate**

Mississippi Department of Agriculture and Commerce  
 P.O. Box 1609  
 Jackson, MS 39215  
**Phone:** (601) 359-1116  
**E-mail:** [adam@mdac.ms.gov](mailto:adam@mdac.ms.gov)

**Jeffrey Clarke**

NGV America  
 400 N. Capitol Street  
 Washington, DC 20001  
**Phone:** (202) 824-7364  
**E-mail:** [jclarke@ngvamerica.org](mailto:jclarke@ngvamerica.org)

**Mike Cleary**

Retired  
 4108 Eunice Way  
 Sacramento, CA 95821  
**Phone:** (916) 483-8498  
**E-mail:** [mcleary55@sbcglobal.net](mailto:mcleary55@sbcglobal.net)

**Steven Cook**

Retired: California Division of Measurement  
 Standards  
 2907 Pasatiempo PL  
 Sacramento, CA 95833  
**Phone:** (916) 717-7856  
**E-mail:** [scooksec@gmail.com](mailto:scooksec@gmail.com)

**Clark Cooney**

NIST, Office of Weights and Measures  
 100 Bureau Drive, MS 2600  
 Gaithersburg, MD 20899-2600  
**Phone:** (301) 975-4615  
**E-mail:** [clark.cooney@nist.gov](mailto:clark.cooney@nist.gov)

**Rodney Cooper**

Tuthill Transfer Systems  
 8825 Aviation Drive  
 Fort Wayne, IN 46809  
**Phone:** (260) 755-7552  
**E-mail:** [rcooper@tuthill.com](mailto:rcooper@tuthill.com)

**Ronny Cornelis**

Cucacao Government- Ministry of Economic  
Development  
Pletterweg 42  
Willemstad, Curacao

**Phone:**

**E-mail:** ronny.cornelis@cobiernu.cw

**Hayden Cornish**

Schenck Process  
746 E. Milwaukee Street  
Whitewater, WI 53190

**Phone:** (262) 473-2441

**E-mail:** h.cornish@schenckprocess.com

**Chuck Corr**

Archer Daniels Midland Company  
1251 Beaver Channel Parkway  
Clinton, IA 52732

**Phone:** (563) 244-5208

**E-mail:** corr@adm.com

**Davis Cosey**

Davis Oil Company  
904 Jernigan Street  
Perry, GA 31069

**Phone:** (478) 987-2443

**E-mail:** dcosey227@davisoilcompany.com

**Constantine Cotsoradis**

Flint Hills Resources  
4111 East 37<sup>th</sup> Street North  
Wichita, KS 67220-3203

**Phone:** (316) 828-6133

**E-mail:** constantine.cotsoradis@fhr.com

**Mark Coyne**

Brockton Weights and Measures  
45 School Street  
City Hall

Brockton, MA 02301-9927

**Phone:** (508) 580-7120

**E-mail:** mcoyne@cobma.us

**John Cruz**

Mercedes-Benz Research and Development North  
America  
3953 Research Park Drive  
Ann Arbor, MI 48108

**Phone:** (734) 395-2315

**E-mail:** john.cruz@daimler.com

**Matthew Curran**

Florida Department of Agriculture and Consumer  
Services

3125 Conner Boulevard

Building 2, Mail Stop L2

Tallahassee, FL 32399-1650

**Phone:** (850) 921-1570

**E-mail:** matthew.curran@freshfromflorida.com

**Ha Dang**

San Diego County Department of Agriculture Weights  
and Measures

9325 Hazard Way

Suite 100

San Diego, CA 92123-1217

**Phone:** (858) 614-7703

**E-mail:** ha.dang@sdcounty.ca.gov

**Bill Deitz**

Sam's Club

2101 Simple Savings Diver

Bentonville, AR 72712

**Phone:** (479) 277-7595

**E-mail:** bill.deitz@samsclub.com

**Rob DeRubeis**

Michigan Department of Agriculture  
940 Venture Lane

Williamston, MI 48895-2451

**Phone:** (517) 655-8202

**E-mail:** derubeisr@michigan.gov

**Linda Doherty**

New Jersey Food Council

30 West Lafayette Street

Trenton, NJ 08608

**Phone:** (609)392-8899

**E-mail:** ldoherty@njfoodcouncil.com

**Tim Elliot**

Washington State Dept. of Agriculture

1111 Washington Street SE

2<sup>nd</sup> Floor

Olympia, WA 98504

**Phone:** (360) 902-1984

**E-mail:** telliott@agr.wa.gov

**Dean Ely**

PA Association of Weights & Measures

332 Washington Avenue

Jersey Shore, PA 17740

**Phone:** (570) 398-2811

**E-mail:** dely@kcnet.org

**Jeff Fantozzi**

Erie County Auditor's Office  
247 Columbus Avenue, #210  
Sandusky, OH 44870  
**Phone:** (419)627-6650  
**E-mail:** atozhil@yahoo.com

**Bob Feezor**

Scales Consulting and Testing  
35 Stonington Place  
Marietta, GA 30068  
**Phone:** (770) 971-7454  
**E-mail:** rkfeezor@bellsouth.net

**Scott Ferguson**

Michigan Department of Agriculture  
940 Venture Lane  
Williamston, MI 48895-2451  
**Phone:** (517)655-8202  
**E-mail:** fergusons9@michigan.gov

**Kevin Ferrick**

API  
1220 L Street NW  
Washington, DC 20005  
**Phone:** (202) 682-8233  
**E-mail:** ferrick@api.org

**Craig Fester**

Pennsylvania Department of Agriculture Bureau of  
Weights and Measures  
2301 North Cameron Street  
Harrisburg, PA 17110  
**Phone:** (717) 787-9089  
**E-mail:** cfester@pa.gov

**David Fialkov**

NATSO  
1330 Braddock Place, #501  
Alexandria, VA 22314  
**Phone:** (703) 739-8501  
**E-mail:** dfialkov@natso.com

**Alyson Fick**

ASTM International  
100 Barr Harbor Drive  
West Conshohocken, PA 19428  
**Phone:** (610) 832-9710  
**E-mail:** afick@astm.org

**Cathy Fisher**

Santa Barbara County Weights and Measures  
263 Camino del Remedio  
Santa Barbara, CA 93110  
**Phone:** (805)681-5600  
**E-mail:** cfisher@co.santa-barbara.ca.us

**Hugh Fleming**

VNG  
150 Monument Road, Suite Bala  
Cynwyd, PA 19004  
**Phone:** (610) 709-5500  
**E-mail:** hfleming@vng.co

**Mark Flint**

Archer Daniels Midland  
4666 Faries Parkway  
Decatur, IL 62526  
**Phone:** (217) 451-3104  
**E-mail:** mark.flint@adm.com

**Darrell Flocken**

National Conference on Weights and Measures, Inc.  
1135 M Street, Suite 110  
Lincoln, Ne 68508  
**Phone:** (614) 620-6134  
**E-mail:** darrell.flocken@ncwm.net

**Kurt E. Floren**

LA County Agriculture Comm/Weights and Measures  
12300 Lower Azusa Road  
Arcadia, CA 91006  
**Phone:** (626) 575-5451  
**E-mail:** kfloren@acwm.lacounty.gov

**Rick Fragnito**

Shell Oil Products  
1000 Main Street  
Houston, TX 77002  
**Phone:** (713) 230-2927  
**E-mail:** rick.fragnito@shell.com

**David Freed**

New Jersey Weights and Measures  
1261 Routes 1 & 9 South  
Avenel, NJ 07001  
**Phone:** 732-815-7805  
**E-mail:** freedd@dca.lps.state.nj.us

**Brad Fryburger**

Right Weigh Innovations  
430 W. South Avenue  
Noble, IL 62868  
**Phone:** (618) 322-4231  
**E-mail:** bradf@rwifab.com

**John Gaccione**

Westchester County Weights and Measures  
148 Martine Avenue  
Room 407  
White Plains, NY 10601  
**Phone:** (914) 995-2164  
**E-mail:** jpg4@westchestergov.com

**Steve Galvan**

Michigan Department of Agriculture  
940 Venture Lane  
Williamston, MI 48895-2451

**Phone:** (517) 622-8202

**E-mail:** galvans@michigan.gov

**Charlie Gardner**

Suffolk County Weights & Measures  
30 Seventh Avenue  
Kings Park, NY 11754

**Phone:** (631) 269-1204

**E-mail:** archgardnr@aol.com

**Bruce Garrett**

Volta Oil Co.  
1 Roberts Road

Plymouth, MA 02360

**Phone:** (508) 747-3778

**E-mail:** abellfield@pmaa.org

**Ron Gibson**

Seraphin Test Measure  
30 Indel Avenue

Rancocas, NJ 08073

**Phone:** (609) 267-0922

**E-mail:** rgibson@pemfab.com

**Steve Giguere**

Maine Department of Agriculture, Conservation and  
Forestry

28 State House Station

Augusta, ME 04333

**Phone:** (207) 287-4456

**E-mail:** steve.giguere@maine.gov

**Jason Glass**

Kentucky Department of Agriculture  
107 Corporate Drive  
Frankfort, KY 40601

**Phone:** (502) 573-0282

**E-mail:** jason.glass@ky.gov

**Paul Glowacki**

Murray Equipment, Inc.  
2515 Charleston Place  
Fort Wayne, IN 46805

**Phone:** (260) 480-1352

**E-mail:** pglowacki@murrayequipment.com

**Angela Godwin**

Ventura County Department of Weights and  
Measures, California

800 S Victoria Ave, #1750

Ventura, CA 93009

**Phone:** (805) 654-2428

**E-mail:** angela.godwin@ventura.org

**Eric Golden**

Cardinal Scale

203 East Daugherty

Webb City, MO 64870

**Phone:** (417) 673-4631

**E-mail:** egolden@cardet.com

**Joe Gomez**

New Mexico Department of Agriculture  
P.O. Box 30005

MSC 3170

Las Cruces, NM 88003-8005

**Phone:** (575) 646-1616

**E-mail:** jgomez@nmda.nmsu.edu

**Frank Greene**

Connecticut Dept of Consumer Protection  
165 Capitol Avenue

Hartford, CT 06106

**Phone:** (860) 713-6168

**E-mail:** frank.greene@ct.gov

**Jeff Griffith**

Marathon Petroleum Co, LP

539 South Main St

Findlay, OH 45840

**Phone:** (419) 672-6591

**E-mail:** jsgriffith@marathonpetroleum.com

**Martin Grindley**

New York City Taxi and Limousine Commission  
24-55 Brooklyn-Queens Expressway

Woodside, NY 11377

**E-mail:** grindleym@tlc.nyc.gov

**Chris Guay**

Procter and Gamble Co.

One Procter and Gamble Plaza

Cincinnati, OH 45202

**Phone:** (513) 983-0530

**E-mail:** guay.cb@pg.com

**Brett Gurney**

Utah Department of Agriculture and Food  
P.O. Box 146500

Salt Lake City, UT 84114-6500

**Phone:** (801) 538-7158

**E-mail:** bgurney@utah.gov

**Ethan Halpern**

Maryland Department of Agriculture  
50 Harry S. Truman Parkway

Annapolis, MD 21401

**Phone:** (410) 841-5790

**E-mail:** halpernea@mda.state.md.us

**Ivan Hankins**

Iowa Department of Agriculture  
Weights and Measures  
2230 S. Ankeny Boulevard  
Ankeny, IA 50023-9093  
**Phone:** (515) 725-1492  
**E-mail:** ivan.hankins@iowaagriculture.gov

**Krister Hard af Segerstad**

IKEA North America Services, LLC  
420 Alan Wood Road  
Conshohocken, PA 19428  
**Phone:** (610) 834-0180  
**E-mail:** krister.hardafsegerstad0@ikea.com

**Bill Hardy**

Power Measurements LLC  
6386 Avington Place  
Gainesville, VA 20155  
**Phone:** (571) 248-7600  
**E-mail:** bill.hardy@powermeasurements.com

**Milton Hargrave**

Virginia Department of Agriculture and Consumer  
Services – Weights and Measures  
P.O. Box 1163  
Richmond, VA 23218  
**Phone:** (804) 786-2476  
**E-mail:** milton.hargrave@vdacs.virginia.gov

**John Harkins**

Sunoco Logistics  
4041 Market Street  
Aston, PA 19014  
**Phone:** (610) 833-3671  
**E-mail:** jjharkins@sunocologistics.com

**Jeff Harmening**

American Petroleum Institute  
1220 L Street NW  
Washington, DC 20005  
**Phone:** 202-682-8310  
**E-mail:** harmeningj@api.org

**Steven Harrington**

Oregon Department of Agriculture  
Weights and Measures Program  
635 Capitol Street NE  
Salem, OR 97301  
**Phone:** (503) 986-4677  
**E-mail:** sharrington@oda.state.or.us

**Rick Harshman**

NIST, Office of Weights and Measures  
100 Bureau Drive, MS 2600  
Gaithersburg, MD 20899-2600  
**Phone:** (301) 975-8107  
**E-mail:** richard.harshman@nist.gov

**Ryanne Hartman**

Michigan Department of Agriculture  
940 Venture Lane  
Williamston, MI 48895-2451  
**Phone:** (517) 655-8202  
**E-mail:** hartmanr4@michigan.gov

**Ron Hasemeyer**

Alameda County Department of Weights and  
Measures  
333 5th Street  
Oakland, CA 94607  
**Phone:** (510) 268-7348  
**E-mail:** ronald.hasemeyer@acgov.org

**Ron Hayes**

Missouri Department of Agriculture  
1616 Missouri Boulevard  
P.O. Box 630  
Jefferson City, MO 65102  
**Phone:** (573) 751-4316  
**E-mail:** ron.hayes@mda.mo.gov

**Scott Henry**

Zebra Technologies  
721 Richmond Court  
Loganville, GA 30052  
**Phone:** (770) 466-3658  
**E-mail:** scott.henry@zebra.com

**Marilyn Herman**

Herman and Associates  
3730 Military Road NW  
Washington, DC 20015  
**Phone:** (202) 362-9520  
**E-mail:** mherman697@aol.com

**Jim Hewston**

J.A. King and Co  
6541 C Franz Warner Parkway  
Whitsett, NC 27377  
**Phone:** (800) 327-7727  
**E-mail:** jim.hewston@jaking.com

**Carol Hockert**

NIST, Office of Weights and Measures  
100 Bureau Drive, MS 2600  
Gaithersburg, MD 20899-2600  
**Phone:** (301) 975-4004  
**E-mail:** carol.hockert@nist.gov

**J. Mike Honsberger**

Marathon Petroleum Company LP  
425 S 20th Street  
Tampa, FL 33605-6025  
**Phone:** (813) 469-9459  
**E-mail:** jmhonsberger@marathonpetroleum.com

**Bill Hornbach**

Chevron Products Company  
6001 Bollinger Canyon Road, Rm. L1056  
San Ramon, CA 94583  
**Phone:** (925) 842-3484  
**E-mail:** billhornbach@chevron.com

**Fran Houston**

Ohio Department of Agriculture  
Division of Weights and Measures  
8995 East Main Street  
Reynoldsburg, OH 43068  
**Phone:** (614) 728-6290  
**E-mail:** fran.elson-houston@agri.ohio.gov

**John Hughes**

Rice Lake Weighing  
230 W Coleman Street  
Rice Lake, WI 54868  
**Phone:** (507) 399-4629  
**E-mail:** jhughes@ricelake.com

**Lori Jacobson**

South Dakota Weights and Measures  
118 W Capitol  
Pierre, SD 57501  
**Phone:** (605) 773-3697  
**E-mail:** lori.jacobson@state.sd.us

**Brad Jandl**

ASTM International  
100 Barr Harbor Drive  
West Conshohocken, PA 19428  
**Phone:** (610) 832-9612  
**E-mail:** bjandl@astm.com

**Randy Jennings**

Tennessee Department of Agriculture  
P.O. Box 40627  
Melrose Station  
Nashville, TN 37204  
**Phone:** (615) 837-5327  
**E-mail:** randy.jennings@tn.gov

**Jeff Jetter**

Honda R&D Americas, Inc.  
1900 Harpers Way  
Torrance, CA 90501  
**Phone:** (310) 994-0713  
**E-mail:** jjetter@hra.com

**Rafael Jimenez**

Association of American Railroad Transportation  
Technology Center  
P.O. Box 11130  
55500 D.O.T. Road  
Pueblo, CO 81001  
**Phone:** (719) 584-0691  
**E-mail:** rafael\_jimenez@ttci.aar.com

**Gordon Johnson**

Gilbarco, Inc.  
7300 West Friendly Avenue  
Greensboro, NC 27410  
**Phone:** (336) 547-5375  
**E-mail:** gordon.johnson@gilbarco.com

**Ronald Johnson**

DC Government Weights and Measures  
Dept. of Consumer & Regulatory  
1100 4<sup>th</sup> Street SW  
Weights and Measures Fourth Floor  
Washington, DC 20024  
**Phone:** (202) 698-2136  
**E-mail:** Ronald.Johnson@dc.gov

**Raymond Johnson Jr.**

New Mexico Department of Agriculture  
P.O. Box 30005  
MSC 3170  
Las Cruces, NM 88003-8005  
**Phone:** (575) 646-1616  
**E-mail:** rjohnson@nmda.nmsu.edu

**Jeri Kahana**

Hawaii Department of Agriculture  
1851 Auiki Street  
Honolulu, HI 96819  
**Phone:** (808) 832-0707  
**E-mail:** Jeri.M.Kahana@hawaii.gov

**Dmitri Karimov**

Liquid Controls  
105 Albrecht Drive  
Lake Bluff, IL 60044  
**Phone:** (847) 283-8317  
**E-mail:** dkarimov@idexcorp.com

**Allen Katalinic**

North Carolina Department of Agriculture  
1050 MSC  
Raleigh, NC 27699  
**Phone:** (919) 707-3225  
**E-mail:** allen.katalinic@ncagr.gov

**Kevin Kean**

Pennsylvania Department of Agriculture Bureau of  
Weights and Measures  
2301 North Cameron Street  
Harrisburg, PA 17110  
**Phone:** (717) 787-9089  
**E-mail:** kkean@pa.gov

**Joe Keenan**

PBF Energy  
1 Sylvan Way  
2nd Floor  
Parsippany, NJ 07054  
**Phone:** (973) 223-6549  
**E-mail:** joseph.keenen@pbfenergy.com

**Michael Keilty**

Endress + Hauser Flowtec AG USA  
2441 Arapaho Road  
Estes Park, CO 80517  
**Phone:** (970) 586-2122  
**E-mail:** michael.keilty@us.endress.com

**Henry Kellogg**

Tolt Solutions  
12123 Churchill Down  
Springdale, AR 72762  
**Phone:** (479) 685-6862  
**E-mail:** henry.kellogg@toltsolutions.com

**Cindy Kennard**

Marathon Petroleum Company, LP  
1000 Ashland Drive  
Suite 201  
Ashland, KY 41101-7057  
**Phone:** (606)326-2519  
**E-mail:** clkennard@marathonpetroleum.com

**John Keppel**

Northampton County Weights and Measures  
669 Washington Street  
Easton, PA 18042-7411  
**Phone:** (610)997-5812  
**E-mail:**

**Brian Kernke**

Musket Corporation  
P.O. Box 26210  
Oklahoma City, OK 73126  
**Phone:** (405) 302-6552  
**E-mail:** brian.kernke@musketcorp.com

**Michael Kerr**

Southern Company Services  
228 Bridle Run  
Somerset, KY 42503  
**Phone:** (606) 305-2419  
**E-mail:** mlkerr@southernco.com

**Navid Khan**

Butte County Agriculture Department  
316 Nelson Ave  
Oroville, CA 95965

**Doug Killingsworth**

Georgia Department of Agriculture  
19 M.L.K. Jr. Drive SW  
Atlanta, GA 30334  
**Phone:** (404) 656-3605  
**E-mail:** william.killingsworth@agr.georgia.gov

**Jean Kliethermes**

Missouri Department of Agriculture  
P.O. Box 630  
Jefferson City, MO 65102  
**Phone:** (573) 751-5638  
**E-mail:** jean.kliethermes@mda.mo.gov

**Elizabeth Koncki**

Maryland Department of Agriculture  
50 Harry S. Truman Parkway  
Annapolis, MD 21401  
**Phone:** (410)841-5790  
**E-mail:** konckiea@mda.state.md.us



**David Kovach**

BP  
150 W. Warrenville Rd.  
MC J-7  
Naperville, IL 60563  
**E-mail:** david.kovach@bp.com

**Jason Kukachka**

Thermo Fisher Scientific  
501 90th Avenue N.W  
Coon Rapids, MN 55433  
**Phone:** (763) 783-2566  
**E-mail:** jason.kukachka@thermofisher.com

**Mike Kunselman**

Center for Quality Assurance  
4800 James Savage Road  
Midland, MI 48642  
**Phone:** (989) 496-2399  
**E-mail:** mkunselman@CenterForQA.com

**Steve Langford**

Cardinal Scale Manufacturing Co.  
203 East Daugherty Street  
P.O. Box 151  
Webb City, MO 64870  
**Phone:** (417) 673-4631  
**E-mail:** slangford@cardet.com

**John Lawn**

Rinstrum, Inc.  
1349 Piedmont Drive  
Troy, MI 48083  
**Phone:** 248-680-0320  
**E-mail:** john.lawn@rinstrum.com

**Rod Lawrence**

Magellan Midstream Partners  
One Williams Center  
Tulsa, OK 74121  
**Phone:** (918) 574-7286  
**E-mail:** rod.lawrence@magellanlp.com

**Robert Legg**

Southwest Research Institute  
6220 Culebra Road  
San Antonio, TX 78238  
**Phone:** (210) 522-2071  
**E-mail:** robert.legg@swri.org

**Dawna Leitzke**

South Dakota Petroleum and Propane Marketers  
Association  
P.O. Box 1058 320 E  
Capitol Pierre, SD 57501  
**Phone:** (605) 224-8606  
**E-mail:** dawnaleitzkeicloud@me.com

**Russ Lewis**

Marathon Petroleum Company LP  
11631 US Route 23  
P.O. Box 911  
Catlettsburg, KY 41129  
**Phone:** (606) 921-2009  
**E-mail:** rplewis@marathonpetroleum.com

**Rich Lewis**

Georgia Department of Agriculture  
Agriculture Building  
19 MLK Drive, Rm 321  
Atlanta, GA 30334  
**Phone:** (404) 656-3605  
**E-mail:** richard.lewis@agr.georgia.gov

**Paul Lewis, Sr.**

Rice Lake Weighing Systems, Inc.  
230 West Coleman Street  
Rice Lake, WI 54868-2404  
**Phone:** (715) 434-5322  
**E-mail:** plewis@ricelake.com

**Tim Lloyd**

Montana Weights and Measures Bureau  
P.O. Box 200516  
Helena, MT 59620-0516  
**Phone:** (406) 443-3289  
**E-mail:** tlloyd@mt.gov

**Shailesh Lopes**

General Motors - Powertrain Division  
823 Joslyn Road  
Mailcode: 483-730-472  
Pontiac, MI 48340  
**Phone:** (248) 891-8827  
**E-mail:** shailesh.lopes@gm.com

**Jerry Lukowiak**

City of East Orange  
143 New Street  
East Orange, NJ 07017  
**Phone:** (201) 953-4260  
**E-mail:** glukowiak@gmail.com

**Brad Lundberg**

Pennsylvania Department of Agriculture Bureau of  
Weights and Measures  
18211 Wright Road  
Centerville, PA 16404  
**Phone:** (814) 332-6890  
**E-mail:** blundberg@pa.gov

**Ed Luthy**

Schenck Process, LLC  
108 Wade Drive  
Dover, OH 44622  
**Phone:** (440) 241-0194  
**E-mail:** e.luthy@schenckprocess.com

**Mike Lynch**

ExxonMobil  
600 Billingsport Road  
Paulsboro, NJ 08066  
**Phone:** (856) 224-2634  
**E-mail:** michael.j.lynch@exxonmobil.com

**Kristin Macey**

California Division of Measurement Standards  
6790 Florin Perkins Rd  
Suite 100  
Sacramento, CA 95828  
**Phone:** 916-229-3000  
**E-mail:** kristin.macey@cdfa.ca.gov

**Roger Macey**

8716 Rubia Drive  
Elk Grove, CA 95624  
**Phone:** (916) 203-3192  
**E-mail:** romac@softcom.net

**Kat Madaras**

Fuel Merchants Association of New Jersey  
66 Morris Avenue  
Springfield, NJ 07081  
**Phone:** (973) 467-1400  
**E-mail:** kmadaras@fmanj.org

**Matthew Maiten**

Santa Barbara County Agriculture Commissions  
263 Camino del Remedio  
Santa Barbara, CA 93110  
**Phone:** (805) 681-5600  
**E-mail:** mmaiten@agcommissioner.com

**Marco Mares**

San Diego County Dept of Agriculture  
Weights and Measures  
9325 Hazard Way, Suite 100  
San Diego, CA 92123-1256  
**Phone:** (858) 614-7726  
**E-mail:** marco.mares@sdcounty.ca.gov

**Kelly Mason**

ExxonMobil  
22777 Springwoods Village Parkway  
Spring, TX 77389  
**Phone:** (609) 462-0163  
**E-mail:** Kelly.j.mason@exxonmobil.com

**Jim McEnerney**

Connecticut Dept of Consumer Protection  
165 Capitol Avenue  
Hartford, CT 06106  
**Phone:** (860) 713-6160  
**E-mail:** james.mcenerney@ct.gov

**Jim McGetrick**

BP  
Mail Code J-8  
150 W. Warrenville Road  
Naperville, IL 60563  
**Phone:** (630) 487-1685  
**E-mail:** james.mcgetrick@bp.com

**Mike McGoff**

Pennsylvania Department of Agriculture Bureau of  
Weights and Measures  
2301 North Cameron Street  
Harrisburg, PA 17110  
**Phone:** (717) 787-9089  
**E-mail:** mmcgoft@pa.gov

**Joe McGonigle**

Pennsylvania Department of Agriculture Bureau of  
Weights and Measures  
2031 North Cameron Street  
Harrisburg, PA 17110  
**Phone:** (717) 787-9089  
**E-mail:** jmcgonigle@pa.gov

**John McGuire**

New Jersey State Office of Weights and Measures  
1261 Routes 1 & 9 South  
Avenel, NJ 07001  
**Phone:** (732) 815-7816  
**E-mail:** john.mcguire@lps.state.nj.us

**Jeff McLaughlin**

Intersystems  
9575 North 109<sup>th</sup> Ave  
Omaha, NE 68142  
**Phone:** (402) 305-3468  
**E-mail:** jmclaughlin@intersystems.net

**Kevin Merritt**

Idaho Weights and Measures  
P.O. Box 790  
Boise, ID 83701-0790  
**Phone:** (208) 332-8690  
**E-mail:** kevin.merritt@agri.idaho.gov

**Rachelle Miller**

Wisconsin Department of Agriculture and Consumer  
Protection  
P.O. Box 8911  
2811 Agriculture Drive  
Madison, WI 53708  
**Phone:** (608) 516-5362  
**E-mail:** rachelle.miller@wisconsin.gov

**Miguel Monroy**

San Francisco Weights and Measures  
1390 Market Street, Suite 910  
San Francisco, CA 94530  
**Phone:** (415) 252-3939  
**E-mail:** miguel.monroy@sfdph.org

**Marcus Moore**

ExxonMobil  
3225 Gallows Road  
Room 6B2117  
Fairfax, VA 22037  
**Phone:** (832) 625-7541  
**E-mail:** marcus.moore@exxonmobil.com

**Joe Moreo**

Modoc County Department of Agriculture  
202 West Fourth Street  
Alturas, CA 96101  
**Phone:** (530)233-6401  
**E-mail:** susiephilpott@co.modoc.ca.us

**Randy Moses**

Wayne  
1000 East Walnut St  
Heritage Campus, Suite 404  
Perkasie, PA 18944  
**Phone:** (215) 257-2759  
**E-mail:** randy.moses@wayne.com

**Bob Murnane**

Seraphin Test Measure, Co.  
30 Indel Avenue  
P.O. Box 227  
Rancocas, NJ 08073-0227  
**Phone:** (609) 267-0922  
**E-mail:** rmurnane@pemfab.com

**Peter Murray**

Chart Inc.  
2200 Airport Industrial Boulevard.  
Bldg. 500  
Ball Ground, GA 30107  
**Phone:** (678) 467-5484  
**E-mail:** peter.murray@chartindustries.com

**Doug Musick**

Kansas Department of Agriculture  
1320 Research Park Drive  
Manhattan, KS 66502  
**Phone:** (785) 564-6681  
**E-mail:** Doug.Musick@KDA.KS.Gov

**Malin Nasman**

IKEA North America Services, LLC  
420 Alan Wood Road  
Conshohocken, PA 19428  
**Phone:** (610) 834-0180  
**E-mail:** malin.nasman@ikea.com

**Josh Nelson**

Oregon Department of Agriculture  
Weights and Measures Program  
635 Capitol Street NE  
Salem, OR 97301-2532  
**Phone:** (503) 986-4751  
**E-mail:** jnelson@oda.state.or.us

**Manuch Nikanjam**

Chevron Global Downstream, LLC  
100 Chevron Way  
Richmond, CA 94801  
**Phone:** (510) 242-2741  
**E-mail:** mnik@chevrontexaco.com

**Tim Niswander**

Kings County  
680 North Campus  
Suite B  
Hanford, CA 93230  
**Phone:** (559) 852-2830  
**E-mail:** tim.niswander@co.kings.ca.us

**Laurence Nolan**

LA County Agriculture Comm.  
Weights and Measures  
11012 Garfield Ave  
South Gate, CA 90280  
**Phone:** (562) 622-0403  
**E-mail:** lnolan@acwm.lacounty.gov

**Neal Nover**

WinWam Software  
3000 Atrium Way, Suite 2203  
Mount Laurel, NJ 08054-3910  
**Phone:** (856) 273-6988  
**E-mail:** NealNov@winwam.com

**Don Onwiler**

National Conference on Weights and Measures, Inc  
1135 M Street, Suite 110  
Lincoln, NE 68508  
**Phone:** (402) 434-4871  
**E-mail:** don.onwiler@ncwm.net

**Henry Oppermann**

Weights and Measures Consulting, LLC  
1300 Peniston Street  
New Orleans, LA 70115  
**Phone:** (504) 896-9172  
**E-mail:** wm-consulting@att.net

**Joe O'Shea**

Pennsylvania Department of Agriculture Bureau of  
Weights and Measures  
2301 North Cameron Street  
Harrisburg, PA 17110  
**Phone:** (717) 787-9089  
**E-mail:** joshea@pa.gov

**Bart O'Toole**

Nevada Division of Measurement Standards  
2150 Frazer Avenue  
P.O. Box 528804  
Sparks, NV 89431  
**E-mail:** botoole@agri.nv.gov

**Nick Owens**

Stark County Weights and Measures  
225 4<sup>th</sup> Street NE  
Canton, OH 44702  
**Phone:** (330) 451-7356  
**E-mail:** njowens@starkcountyohio.gov

**Tom Palace**

PMCA of Kansas  
P.O. Box 678  
Topeka, KS 66601  
**Phone:** (785) 233-9655  
**E-mail:** tom@pmcaofks.org

**Brian Parnell**

MAPCO Express, Inc.  
7102 Commerce Way  
Brentwood, TN 37027  
**Phone:** (615) 224-1169  
**E-mail:** gbparn.ncwm@gmail.com

**David Paul**

Curb  
229 Berkeley Street, #400  
Boston, MA 02116  
**Phone:** (703) 579-6911  
**E-mail:** dmp@taximagic.com

**Robert Peterson**

Ministry of Economic Development  
Pletterweg 43  
Willemstad, Curacao  
**Phone:** 5999-5297283  
**E-mail:** robert.peterson@gobiernu.cw

**Laura Phillips**

Pennsylvania Department of Agriculture Bureau of  
Weights and Measures  
2301 North Cameron Street  
Harrisburg, PA 17110  
**Phone:** (717) 787-9089  
**E-mail:** laphillips@pa.gov

**Summer Pieretti**

Pennsylvania Department of Agriculture Bureau of  
Weights and Measures  
2301 North Cameron Street  
Harrisburg, PA 17110  
**Phone:** (717) 787-9089  
**E-mail:** spieretti@pa.gov

**Richard Price**

Butte Co Weights & Measures  
316 Nelson Avenue  
Oroville, CA 95965  
**Phone:** (530) 538-7381  
**E-mail:** rprice@buttecounty.net

**Hal Prince**

Florida Department of Agriculture and Consumer Services  
6626 Lake Kirkland Drive  
Clermont, FL 34714  
**Phone:** (850) 921-1570  
**E-mail:** harold.prince@freshfromflorida.com

**Julie Quinn**

Minnesota Weights & Measures Division  
14305 South Cross Drive, Suite 150  
Burnsville, MN 55306  
**Phone:** (651) 539-1555  
**E-mail:** julie.quinn@state.mn.us

**Dave Quinn**

4153 Telfair Lane SE  
Southport, NC 28461  
**Phone:** (910)253-1424  
**E-mail:** deeque@mindspring.com

**Robert Quintero**

Zebra Technologies  
1 Zebra Plaza MS-A21  
Holtsville, NY 11742  
**Phone:** (631) 738-3922  
**E-mail:** robert.quintero@zebra.com

**Dave Rajala**

Total Meter Services, Inc.  
136 Queen Anne Drive  
Hollidaysburg, PA 16648-9228  
**Phone:** (814) 693-1055  
**E-mail:** drajala@totalmeter.com

**Ken Ramsburg**

Maryland Department of Agriculture  
50 Harry S. Truman Parkway  
Annapolis, MD 21401  
**Phone:** (410) 841-5790  
**E-mail:** kenneth.ramsburg@maryland.gov

**Doug Rathbun**

Illinois Department of Agriculture  
801 Sangamon Avenue  
P.O. Box 19281  
Springfield, IL 62794-9281  
**Phone:** (217) 785-8300  
**E-mail:** doug.rathbun@illinois.gov

**Fatine Rattoun**

Sunoco Logistics  
One Fluor Daniel Drive  
Bldg A/L 2  
Sugar Land, TX 77478  
**Phone:** (325) 513-8196  
**E-mail:** frattoun@sunocologistics.com

**Joanne Rausen**

New York City Taxi and Limousine Commission  
33 Beaver Street  
22nd Floor  
New York, NY 10004  
**Phone:** (212) 676-1186  
**E-mail:** rausenj@tlc.nyc.gov

**Tyler Reeder**

National Conference on Weights and Measures, Inc.  
1135 M Street, Suite 110  
Lincoln, NE 68508  
**Phone:** (402) 434-4880  
**E-mail:** tyler.reeder@ncwm.net

**Derek Regal**

Tesoro Companies, Inc.  
19100 Ridgewood Parkway  
San Antonio, TX 78259  
**Phone:** (210) 626-7317  
**E-mail:** derek.b.regal@tsocorp.com

**Wayne Reinert**

Colorado Oil and Public Safety  
633 17<sup>th</sup> Street, Suite 500  
Denver, CO 80202  
**Phone:** (303) 883-8323  
**E-mail:** wayne.reinert@state.co.us

**Walt Remmert**

Pennsylvania Department of Agriculture  
2301 North Cameron Street  
Harrisburg, PA 17110  
**Phone:** (717) 787-9089  
**E-mail:** wremmert@pa.gov

**Rebecca Richardson**

MARC IV Consulting  
2005 Tin Cup Road  
Mahomet, IL 61853  
**Phone:** (217) 419-3543  
**E-mail:** rrichardson@marciv.com

**Ralph Richter**

NIST, Office of Weights and Measures  
 100 Bureau Drive, MS 2600  
 Gaithersburg, MD 20899-2600  
**Phone:** (301) 975-3997  
**E-mail:** ralph.richter@nist.gov

**Bob Roach**

Monterey County Agricultural Commissioner's Office  
 1428 Abbott Street  
 Salinas, CA 93901  
**Phone:** (831) 759-7325  
**E-mail:** roachb@co.monterey.ca.us

**Mark Robbins**

Salem County Weights & Measures  
 110 5th Street, Suite 800  
 Salem, NJ 08079  
**Phone:** (856)339-8608  
**E-mail:** mrobbins@salemcountynj.gov

**Gene Robertson**

Mississippi Department of Agriculture and Commerce  
 P.O. Box 1609  
 Jackson, MS 39215-1609  
**Phone:** (601)359-1111  
**E-MAIL:** gene@mdac.state.ms.us

**Lance Robertson**

Measurement Canada  
 151 Tunney's Pasture Driveway  
 Ottawa, ON K1A 0C9  
**Phone:** (613) 952-0661  
**E-MAIL:** lance.robertson@ic.gc.ca

**Craig Rodine**

ChargePoint, Inc.  
 254 East Hacienda Avenue  
 Campbell, CA 95008  
**Phone:** (408) 319-7307  
**E-mail:** craig.rodine@chargepoint.com

**Doug Rudy**

Pennsylvania Department of Agriculture Bureau of  
 Weights and Measures  
 2301 North Cameron Street  
 Harrisburg, PA 17110  
**Phone:** (717) 787-9089  
**E-mail:** drudy@pa.gov

**Lou Sakin**

Towns of Hopkinton/Northbridge  
 1 Ford Lane  
 Framingham, MA 01701  
**Phone:** (508) 620-1148  
**E-mail:** louissakin@aol.com

**Michael Santos**

Warren County Weights and Measures  
 2 Furnace Street  
 P.O. Box 359  
 Oxford, NJ 07863  
**Phone:** (908) 453-2828  
**E-mail:** weights-measures@co.warren.nj.us

**Brett Saum**

Retired  
 5660 North Prospect Avenue  
 Fresno, CA 93711  
**Phone:** (559) 435-0357  
**E-mail:** bsaum@comcast.net

**Richard Scali**

Town of Barnstable  
 200 Main Street  
 Hyannis, MA 02601  
**Phone:** (508) 862-4778  
**E-mail:** richard.scali@town.barnstable.ma.us

**Prentiss Searles**

American Petroleum Institute  
 1220 L Street NW  
 Washington, DC 20005  
**Phone:** (202) 682-8227  
**E-mail:** searlesp@api.org

**David Sefcik**

NIST, Office of Weights and Measures  
 100 Bureau Drive, MS 2600  
 Gaithersburg, MD 20899-2600  
**Phone:** (301) 975-4868  
**E-mail:** david.sefcik@nist.gov

**Marty Settevendemie**

San Luis Obispo County Weights and Measures  
 2156 Sierra Way, Suite A  
 San Luis Obispo, CA 93401  
**Phone:** (805) 781-5913  
**E-mail:** msettevendemie@co.slo.ca.us

**Dick Shipman**

Rice Lake Weighing Systems  
 230 West Coleman Street  
 Rice Lake, WI 54868  
**Phone:** (715) 234-9171  
**E-mail:** rshipman@ricelake.com

**Jenny Sigelko**

Volkswagen Group of America  
 3800 Hamlin Road  
 Auburn Hills, MI 48326  
**Phone:** (248) 754-4214  
**E-mail:** jenny.sigelko@vw.com

**Mike Sikula**

New York Dept. of Agriculture & Markets  
10B Airline Drive  
Albany, NY 12235  
**Phone:** (518) 457-3452  
**E-mail:** mike.sikula@agriculture.ny.gov

**Jo Jo Silvestro**

Gloucester Co. New Jersey  
64 Forage Drive  
Mickleton, NJ 08056  
**Phone:** (856) 423-5360  
**E-mail:** silver7777@comcast.net

**Scott Simmons**

Colorado Oil and Public Safety  
633 17th Street, Suite 500  
Denver, CO 80202  
**Phone:** (303) 378-1103  
**E-mail:** scott.simmons@state.co.us

**Peter Sirrico**

Thayer Scale/Hyer Industries  
91 Schoosett Street  
P.O. Box 669  
Pembroke, MA 02359  
**Phone:** (781) 826-8101  
**E-mail:** psirrico@thayerscale.com

**N. David Smith**

North Carolina Department of Agriculture  
1050 Mail Service Center  
Raleigh, NC 27699-1050  
**Phone:** (919) 707-3033  
**E-mail:** david.smith@ncagr.gov

**Dan Smith**

Alaska Division of Measurement Standards/CVE  
11900 Industry Way  
Bldg. M, Suite 2  
Anchorage, AK 99515  
**Phone:** (907) 365-1210  
**E-mail:** dan.smith1@alaska.gov

**Bryan Snodgrass**

West Virginia Weights & Measures Division of Labor  
570 McCorkle Avenue West  
St. Albans, WV 25177  
**Phone:** (304)722-0602  
**E-mail:** bryan.k.snodgrass@wv.com

**Josh Stepanian**

Pennsylvania Department of Agriculture  
Bureau of Weights and Measures  
2301 North Cameron Street  
Harrisburg, PA 17110  
**Phone:** (717) 787-9089  
**E-mail:** jstepanian@pa.gov

**John Stokes**

South Carolina Department of Agriculture  
P.O. Box 11280  
Columbia, SC 29211  
**Phone:** (803)737-9690  
**E-mail:** jstokes@scda.sd.gov

**Brad Stotler**

NATSO, Representing America's Travel Plazas and  
Truckstops  
1330 Braddock Place, Suite 501  
Alexandria, VA 22314  
**Phone:** (202) 309-0400  
**E-mail:** bstotler@natso.com

**Fred Strathmeyer, Jr.**

Pennsylvania Dept. of Agriculture  
2301 N Cameron Street  
Harrisburg, PA 17110  
**Phone:** (717) 214-3758  
**E-mail:** fstrathmey@pa.gov

**Lou Straub**

Fairbanks Scales, Inc.  
3056 Irwin Drive S.E.  
Southport, NC 28461  
**Phone:** (910) 253-3250  
**E-mail:** lstraub@fairbanks.com

**Elisa Stritt**

National Conference on Weights and Measures, Inc  
1135 M Street, Suite 110  
Lincoln, NE 68508  
**Phone:** (402) 434-4872  
**E-mail:** elisa.stritt@ncwm.net

**Dick Suiter**

Richard Suiter Consulting  
9819 Anchor Bend  
McCordsville, IN 46055  
**Phone:** (317) 336-9819  
**E-mail:** Rsuiter700@aol.com

**James Thomas**

ASTM International  
100 Barr Harbor Drive  
West Conshohocken, PA 19428  
**E-mail:** jstthomas@astm.org

**Ken Tichota**

Nebraska: FSCP- Weights and Measures  
301 Centennial Mall South  
P.O. Box 94757  
Lincoln, NE 68509-4757  
**Phone:** (402) 471-3422  
**E-mail:** ken.tichota@nebraska.gov

**Bill Timmons**

City of Medford  
85 George P. Hassett Drive  
Medford, MA 02155  
**Phone:** (781) 393-2463  
**E-mail:** mwtimmons@medford.org

**Stan Toy**

Santa Clara County Weights and Measures  
1553 Berger Dr  
Building 1, 2nd Floor  
San Jose, CA 95112  
**Phone:** (408) 918-4633  
**E-mail:** stan.toy@aem.sccgov.org

**Daniel Tramp**

USC, LLC  
2320 124th Road  
Sabetha, KS 66534  
**Phone:** (785) 547-5558  
**E-mail:** danieltramp@uscllc.com

**Ron Travis**

Travis Scale Company  
61 West Tucker Road  
Liberal, KS 67901  
**Phone:** (620) 626-5940  
**E-mail:** ron@travisscale.com

**Scott Traynor**

Camden County Weights and Measures  
512 Lakeland Road, Sutie 158  
Blackwood, NJ 08012  
**Phone:** (856) 374-6393  
**E-mail:** straynor@camdencounty.com

**Jim Truex**

National Conference on Weights and Measures, Inc  
88 Carryback Drive  
Pataskala, OH 43062  
**Phone:** (740) 919-4350  
**E-mail:** jim.truex@ncwm.net

**Rich Tucker**

RL Tucker Consulting, LLC  
605 Bittersweet Lane  
Ossian, IN 46777  
**Phone:** (260) 622-4243  
**E-mail:** rtucker83@comcast.net

**Ann Turner**

605 Tegner Way  
Rockville, MD 20850  
**Phone:** (301) 762-7930  
**E-mail:** apturner88@yahoo.com

**David Turning**

New Mexico Department of Agriculture  
P.O. Box 30005  
MSC 3170  
Las Cruces, NM 88003-8005  
**Phone:** (575) 646-1616  
**E-mail:** dturning@nmda.nmsu.edu

**Val Ughetta**

Alliance of Automobile Manufactures  
1401 Eye Street NW, #900  
Washington, DC 20005  
**Phone:** (202) 326-5549  
**E-mail:** vughetta@autoalliance.org

**Derek Underwood**

South Carolina Department of Agriculture  
123 Ballard Court  
West Columbia, SC 29172  
**Phone:** (803) 737-9700  
**E-mail:** dunder@scda.sc.gov

**Rob Underwood**

Petroleum Marketers Association of America  
1901 N Fort Myer Drive, Suite 500  
Arlington, VA 22209  
**Phone:** (703) 351-8000  
**E-mail:** runderwood@pmaa.org

**Rob Upright**

Vishay Transducers  
42 Countryside Road  
North Grafton, MA 01536  
**Phone:** (508) 615-1185  
**E-mail:** rob.upright@vishaypg.com

**Marie Valentine**

Toyota  
1555 Woodridge  
Ann Arbor, MI 48105  
**Phone:** (734) 995-3692  
**E-mail:** marie.valentine@tema.toyota.com



**Craig VanBuren**

Michigan Department of Agriculture  
940 Venture Lane  
Williamston, MI 48895-2451  
**Phone:** (517) 655-8202  
**E-mail:** vanburenc9@michigan.gov

**Elaine Vieira**

Boston ISD Weights and Measures  
1010 Massachusetts Avenue  
Boston, MA 02118-2606  
**Phone:** (617) 635-5328  
**E-mail:** lillane@aol.com; elaine.morash@boston.gov

**Gilles Vinet**

Measurement Canada  
151 Tunney's Pasture Driveway  
Ottawa, ON K1A 0C9  
**Phone:** (613) 941-8918  
**E-mail:** gilles.vinet@ic.gc.ca

**Russ Vires**

Mettler-Toledo, LLC  
1150 Dearborn Drive  
Worthington, OH 43085  
**Phone:** (614) 438-4306  
**E-mail:** russ.vires@mt.com

**Alan Walker**

Florida Department of Agriculture and Consumer Services  
6260 Buckingham Road  
Fort Myers, FL 33905  
**Phone:** (850) 274-9044  
**E-mail:** alan.walker@freshfromflorida.com

**Jack Walsh**

Town of Wellesley  
525 Washington St  
Town Hall Wellesley  
Wellesley, MA 02482  
**Phone:** (774) 279-2559  
**E-mail:** JackBWalsh@verizon.net

**Ryan Wanttaja**

New York City Taxi and Limousine Commission  
33 Beaver Street  
22nd Floor  
New York, NY 10004  
**Phone:** (212) 676-1055  
**E-mail:** wanttajar@tlc.nyc.gov

**Otto Warnlof**

9705 Inaugural Way  
Gaithersburg, MD 20886  
**Phone:** (301) 926-8155  
**E-mail:** warnlof@verizon.net

**Bob Weidler**

Wyoming Department of Agriculture  
2219 Carey Avenue  
Cheyenne, WY 82002  
**Phone:** (307) 777-7556  
**E-mail:** robert.weidler@wyo.gov

**Tim White**

Michigan Department of Agriculture  
940 Venture Lane  
Williamston, MI 48895-2451  
**Phone:** (517) 655-8202  
**E-mail:** whitet@michigan.gov

**Rich Whiting**

American Wood Fibers  
9841 Broken Land Parkway, #302  
Columbia, MD 21046  
**Phone:** (410)290-8700  
**E-mail:** rwhiting@awf.com

**Barry Wieck**

Ocean County New Jersey  
1027 Hooper Ave, Building 2  
P.O. Box 2191  
Toms River, NJ 08754  
**Phone:** (732) 929-2166  
**E-mail:** bwieck@co.ocean.nj.us

**Jeff Wiles**

Pennsylvania Department of Agriculture  
Bureau of Weights and Measures  
2301 North Cameron Street  
Harrisburg, PA 17110  
**Phone:** (717) 787-9089  
**E-mail:** jefwiles@pa.gov

**Bobbie Willhite**

San Bernardino County  
Dept. of Agriculture  
Weights and Measures  
777 East Rialto Avenue  
San Bernardino, CA 92346  
**Phone:** (909)387-2117  
**E-mail:** rwillhite@awm.sbcounty.gov

**Curt Williams**

CP Williams Energy Consulting, LLC  
95 Roundtree Court  
Stockbridge, GA 30281  
**Phone:** (770) 957-6992  
**E-mail:** curtispwilliams@aol.com

**Bob Williams**

Tennessee Department of Agriculture  
P.O. Box 40627  
Melrose Station  
Nashville, TN 37204-0627  
**Phone:** (615) 837-5109  
**E-mail:** robert.g.williams@tn.gov

**Cary Woodward**

Hamilton County Weights & Measures  
1717 Pleasant Street, Ste 150  
Noblesville, IN 46060  
**Phone:** (317) 403-0639  
**E-mail:** cary.woodward@hamiltoncounty.in.gov

**John Worth**

Mercer County Weights & Measures  
640 South Broad Street  
Trenton, NJ 08611  
**Phone:** (609) 989-6875  
**E-mail:** jworth@mercercounty.org

**Phil Wright**

Texas Dept. of Ag.  
1700 N. Congress Avenue  
P.O. Box 12847  
Austin, TX 78711  
**Phone:** (512) 463-5706  
**E-mail:** philip.wright@texasagriculture.gov

**John Young**

Yolo County Agriculture Department  
70 Cottonwood Street  
Woodland, CA 95695  
**Phone:** (530) 666-8148  
**E-mail:** john.young@yolocounty.org

**Calvin Young**

KSi Conveyors, Inc.  
454 North State Route 49  
P.O. Box 69  
Cissna Park, IL 60924  
**Phone:** (785) 284-2458  
**E-mail:** cyoung@ksiconveyors.com

**Victor Zamora**

West Virginia Weights and Measures Division of  
Labor  
Capitol Complex Bldg 6  
Room 749-B  
Charleston, WV 25305  
**Phone:** (304) 722-0602  
**E-mail:** victor.l.zamora@wv.gov

**Adrian Zavala**

LA County Agric Comm/Weights & Measures  
121012 Garfield Avenue  
South Gate, CA 90280  
**Phone:** (562) 622-0414  
**E-mail:** azavala@acwm.lacounty.gov

**Jane Zulkiewicz**

Town of Barnstable  
200 Main Street  
Hyannis, MA 02601  
**Phone:** (505) 862-4773  
**E-mail:** jane.zulkiewicz@town.barnstable.ma.us

THIS PAGE INTENTIONALLY LEFT BLANK