

INTERFERENCE METHODS FOR STANDARDIZING AND TESTING PRECISION GAGE BLOCKS

By C. G. Peters and H. S. Boyd

ABSTRACT

Precision gages, which are blocks of metal (usually steel), having two opposite faces plane, parallel, and a specified distance apart, are used in the shop as reference end standards for checking micrometers and other measuring instruments, and also as distance pieces or size blocks for precise mechanical work. The extensive use of precision gages necessitated by the small tolerances allowed in the manufacture of interchangeable machine parts has required more accurately determined end standards and more rapid and precise methods for comparing gages with these standards than have been previously available.

Since comparisons of end standards with line standards by means of micrometer-microscopes and of precision gages with end standards by means of contact instruments are subject to appreciable errors, methods which make use of the interference of light waves were used in making these measurements. With the interference methods described in this article the planeness and parallelism errors of precision surfaces can be measured, and the length of standard gages can be determined by direct comparison with the standard light waves with an uncertainty of not more than a few millionths of an inch. The errors of other gages can be determined by comparison with these calibrated standards with equal precision. This process makes the standard light waves, which have been determined to one part in four or five million relative to the international meter the standards of length for this work.

The apparatus used for calibrating standards and comparing other gages with these standards is illustrated by line drawings and thoroughly explained.

CONTENTS

	Page
I. Introduction.....	678
II. Optical method.....	679
III. Interference of light.....	681
IV. Test for planeness of surfaces.....	684
1. Perpendicular incidence.....	684
2. Errors of interpretation.....	688
V. Adherence of surfaces.....	690
VI. Test for parallelism of surfaces.....	692
VII. Calibration of end standards with the Fabry and Perot interferometer...	693
1. General plan of apparatus.....	693
2. Source of light.....	694
3. Interferometer.....	694
4. Constant-temperature chamber.....	695
5. Spectrograph.....	695
6. Photographic.....	695
7. Determination of the order of interference.....	696

	Page
VII. Calibration of end standards with Fabry and Perot interferometer—Con.	
8. Correction of λ	697
9. Correction for the thickness of the platinum films.....	698
10. Correction for nonparallelism of the gage surfaces.....	698
11. Computations.....	699
12. Accuracy and sources of error.....	699
VIII. Comparison of gages with standards.....	704
1. Comparison of length.....	704
2. Comparison of parallelism of surfaces.....	706
IX. Intercomparison of three gages.....	708
X. Development of standard gages.....	710
XI. Comparison between gages and other objects.....	712
XII. Summary.....	713

I. INTRODUCTION

Precision gages, which are blocks of metal (usually steel) having two opposite faces plane, parallel, and a specified distance apart are used in the shop as reference end standards for checking micrometers and other measuring instruments, and also as distance pieces or size blocks for precise mechanical work. The extensive use of precision gages necessitated by the small tolerances allowed in the manufacture of interchangeable machine parts, and the development of the process of making these gages with errors of construction that seldom amount to 0.5 micron (0.00002 inch)—in most cases to not more than 0.25 micron (0.00001 inch)—have created a need for more rapid and precise methods of test and also for more accurately determined reference standards than have been available. Since tests of the accuracy of precision gages can be most readily made by comparison with secondary end standards of the same size and shape, gage blocks with very nearly perfect surfaces can be used in the testing laboratory as secondary end standards when they have been accurately calibrated relative to some fundamental standard of length and when it has been proved that they retain their dimensions for a considerable period of time.

The fundamental standard of length, the International Prototype Meter, is a line standard whose length is the distance between two lines ruled on a platinum-iridium bar carefully preserved in a special vault at the International Bureau of Weights and Measures near Paris. A duplicate of this bar, Meter No. 27, which is kept at the Bureau of Standards, is the primary standard of length for the United States. Other similar bars, graduated in various subdivisions of a meter and calibrated relative to the primary standards, are used as secondary or working standards. In calibrating these secondary and intermediate line standards errors of 0.2 micron

(0.000008 inch) are possible, due to imperfections in the ruled lines.

The end standards of the Bureau of Standards have been calibrated heretofore by comparison with these line standards by the methods of Fizeau¹ and Fischer.² These methods, requiring the use of microscopes, are subject to errors of measurement which may amount to 0.5 micron (0.00002 inch).

The comparisons between the secondary end standards and the precision gages are usually made with contact comparators subject to errors of 0.5 micron (0.00002 inch).

Inasmuch as the tolerance on some machine work is ± 2.5 microns (± 0.0001 inch), requiring the precision gage of the shop to be correct within 0.25 to 0.5 micron (one or two hundred-thousandths of an inch), this degree of precision in the gages requires the secondary end standards of the testing laboratory to be correct within a few hundredths of a micron (millionths of an inch). This tolerance also requires that the errors of measurement in making the comparison between the gages and the standards should likewise be limited to a few hundredths of a micron. It is impossible to attain this precision in measuring the irregularities in the surfaces of gages or end standards with any micrometric apparatus, in calibrating end standards by comparison with line standards, or or in making comparisons between end standards and precision gages with any contact apparatus, because in each case the error of measurement may be several times the allowable error. The error of measurement in the step from the standard meter to the gage should not be more than 0.02 to 0.06 micron (one to three millionths of an inch).

In December, 1917, we undertook to develop an optical method for making these measurements, and in a short time, by applying methods which make use of the interference of light waves, succeeded in solving the problem.³

II. OPTICAL METHOD

Instead of calibrating the end standards by direct comparison with line standards derived from the meter the lengths of standard light waves were chosen as the primary standards. These

¹ Travaux et Mémoires du Bureau International des Poids et Mesures, 10.

² Bull. Phil. Soc. of Washington, 13, p. 241; 1898.

³ Reports on these methods have been given at the following meetings: Peters, American Society of Mechanical Engineers, New York, Dec. 5, 1918. Peters and Boyd, American Physical Society, Washington, Apr. 25, 1919; American Society of Mechanical Engineers, Washington, May 30, 1919; and Philosophical Society of Washington, May 29, 1920. A popular article on the methods was published by Peters and Boyd in the American Machinist, Sept. 30 and Oct. 7, 1920.

waves possess all the necessary properties of fundamental units of length, the most important of which are constancy, reproducibility, accuracy of measurement, and ease of application. As to their constancy, reproducibility, and accuracy of determination little need be said. The wave lengths of red, yellow, and green radiations from cadmium have been determined by direct comparison with the standard meter by Michelson⁴ in 1893 and re-determined by Fabry and Benoit⁵ in 1907, the values obtained from these two independent determinations agreeing to one part in sixteen million when corrected to similar conditions.

Numerous comparisons made by spectroscopists between these fundamental wave lengths and the wave lengths emitted by other luminous substances prove that the light waves are the most dependable length units known. Their work has placed at our disposal a large number of light sources which can be easily obtained and operated and which emit radiations whose wave lengths are known to one part in four or five million. The only remaining requirement is the easy application of these waves in the calibration of end standards.

In making this application incandescent neon and helium gases, giving wave lengths ranging from 0.40 to 0.75 micron (0.000016 to 0.000030 inch) were used. These have been determined⁶ with an accuracy of one part in four or five million and found to be exactly reproducible within the limits of observational error. For an accuracy of one millionth of an inch a comparison with these waves is therefore exactly equivalent to a comparison with the standard meter.

Three sets of carefully selected gages, each containing 81 blocks of various lengths from 0.05 to 4 inches, were chosen as the secondary end standards for gage calibration by interference methods. The planeness and parallelism of the surfaces and length of the gages were determined by means of the interference fringes seen in monochromatic light. To test for planeness, a glass true plane was placed over each gage surface and the curvature of the interference fringes in monochromatic light was determined by means of the Pulfrich instrument described below. Each gage was then made the separator for two interferometer plates, thus forming a Fabry and Perot interferometer. Lack of parallelism of the sur-

⁴ Michelson, *Travaux et Mémoires du Bureau International des Poids et Mesures*, 2; 1895.

⁵ Fabry and Benoit, *Travaux et Mémoires*, 15; 1913.

⁶ Burns, Meggers, and Merrill, *B. S. Sci. Papers*, No. 329; 1918.

faces was determined on moving the eye across the plates by the expansion or contraction of the circular (Haidinger) rings, produced when the interferometer was illuminated with radiation from a helium source. The distance between the interferometer plates was determined from measurements on the diameters of these rings. From this determination, by applying corrections for the density of the air, lack of parallelism of the gage surfaces, and thickness of the metallic film on the interferometer plates, the length of the gage was obtained.

Several independent determinations made the same day on a given gage agreed to 0.025 micron (0.000001 inch). Intercomparisons between similar gages from different sets and between combinations of different gages proved that errors in the determinations of these gages were in no case greater than 0.07 micron (0.000003 inch), and these errors were due in most cases to irregularities in the surfaces of the gages. With perfect gages and accurately controlled conditions the precision of the measurements should be comparable with the highest precision obtainable in wave-length measurements.

After these end standards were calibrated a large number of precision gages were compared with them by means of an interferometer comparator. With this instrument one person is able to test the planeness and parallelism of the surfaces and length of about 100 gages per day with an uncertainty of not more than 0.07 micron (0.000003 inch). During the past year about 30 000 precision gages have been tested at the Bureau of Standards by two workers, which shows that the method is sufficiently rapid for quantity work.

Thus it has been possible to originate, by the method fully described below, end standards directly from the standard light waves and to compare large numbers of commercial gages with these standards by means of light interference, with an accuracy far greater than can be attained in the manufacturing shops of the country.

III. INTERFERENCE OF LIGHT

The sensation of light is due to transverse waves radiated by luminous bodies. These waves vary in length, giving rise to different color sensations. The range of the wave lengths visible to the eye is from about 0.4 micron (0.000016 inch) for blue light to 0.7 micron (0.000028 inch) for red.

If two trains of waves from one point in a source having traversed different paths fall upon a point on the retina of the eye, the resultant amplitude of vibration determines the brightness. If they are "in step," maximum brightness results. If, however, the troughs of the one arrive with the crests of the other, destructive interference takes place, resulting in relative darkness. If the two trains travel different distances, so that the difference in path is some whole number of wave lengths, then the waves will reach the eye in phase. If the difference in path is equal to some whole number of wave lengths plus one-half wave length, the waves in the two trains will be in opposite phase, so that destructive interference takes place. The conditions for interference are realized when light from an extended source *S*, Fig. 1, falls on a thin transparent film. Part of the light is reflected from the first surface, *ABCD*, and the remainder is transmitted to the second surface, *ABGF*, where partial reflection again takes place. Since the wave trains reaching *E* from these two reflections have traveled over different distances, reinforcement or destructive interference can, therefore, occur. When white light is used and the film is sufficiently thin, a few brightly colored bands are seen across its surface. If monochromatic light—that is, light of one color or of very limited spectral extent—be employed, alternate light and dark bands or interference fringes may be observed to cross the film.

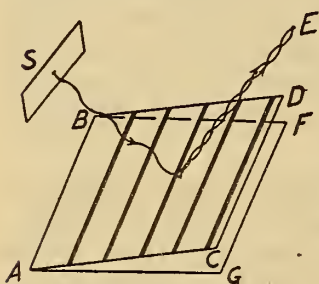

FIG. 1.—Interference of light reflected from the surfaces of a thin film

When white light is used and the film is sufficiently thin, a few brightly colored bands are seen across its surface. If monochromatic light—that is, light of one color or of very limited spectral extent—be employed, alternate light and dark bands or interference fringes may be observed to cross the film.

If one of the surfaces of the film be plane, the shape of the other surface can be obtained from measurements of the film thickness at several points. To derive the relation between the film thickness t and the shape of the interference fringes, consider the thin film formed by the two plane surfaces which are represented by the traces *AC* and *AG*, Fig. 2, inclined at a slight angle ϕ . Observing the film at an angle θ with the normal, rays of light originating at the point *S* in the source and reflected by the two surfaces *AC* and *AG* will appear to come from the two sources S_1 and S_2 . The difference in path of two rays reaching *E* is $N\lambda$, where N is the "order of interference" or number of waves in the

distance S_2K and λ is the wave length of the monochromatic light. Let the distance between the two images of the source $S_1S_2 = h$.

$$\begin{aligned}
 N\lambda &= h \cos (\theta + \alpha) \\
 &= h \cos \theta \cos \alpha - h \sin \theta \sin \alpha \\
 &= 2(a+b) \sin \phi \cos \theta - 2d \sin \phi \sin \theta \\
 &= 2(a+b) \sin \phi \cos \theta - 2b \sin \phi \cos \theta \\
 &= 2a \sin \phi \cos \theta \\
 &= 2t \cos \theta.
 \end{aligned}
 \tag{1}$$

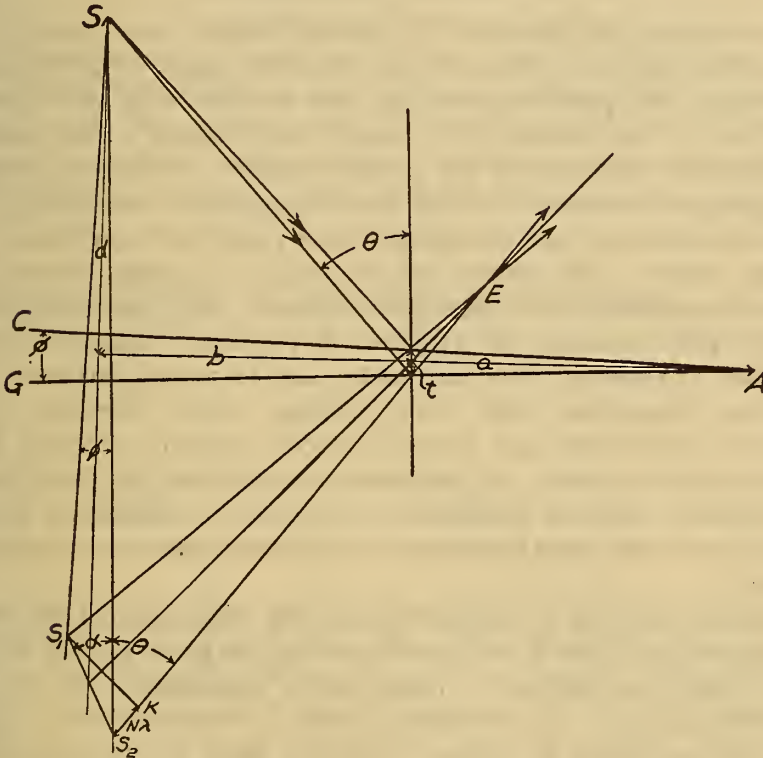

FIG. 2.—Relation between the film thickness and the order of interference

If N is an integer, the two wave trains will be opposite in phase, due to the phase change $\left(\frac{\lambda}{2}\right)$ by reflection at the denser medium,⁷ and the point observed will in that case appear dark. The locus of the points for which N is a given integer is the interference fringe of the N th order and appears as a dark band across the film.

⁷ Only under special cases is this phase change exactly a half wave length; but it is not necessary in the present case to determine its exact value.

Equation (1) may also be expressed in the form

$$t = N \frac{\lambda}{2} \frac{l}{P}, \quad (2)$$

where P represents the perpendicular distance from E to the film and l the distance from E to the point at which t is taken.

IV. TEST FOR PLANENESS OF SURFACES

1. PERPENDICULAR INCIDENCE

In testing the planeness of polished surfaces, such as are produced on prisms, surface plates, precision gages, or micrometer anvils, a test plate is placed in close contact with and slightly inclined to the surface to be tested, thus forming a thin wedge-shaped film discussed in the previous section. This test plate is of glass, one surface of which has been polished accurately true plane and tested against a master true plane or liquid surface of large extent. The accuracy of the test is, of course, limited by the irregularities of the test-plate surface. It is very difficult to make glass surfaces 50 to 75 mm (2 to 3 inches) in diameter plane within 0.25 micron (0.000010 inch), and to reduce this error requires exceptional skill. For ordinary work, however, test plates plane within 0.25 micron (0.00001 inch) are sufficient, but when it is necessary to determine irregularities of a few hundredths of a micron (millionths of an inch) in the surface under test, great care must be exercised in selecting and testing the test plate.

In order to give a definite value to the wave length λ , the thin wedge-shaped film of air formed between the plane surface of the test plate and the surface under test is illuminated with monochromatic light. A convenient source of monochromatic light is a Bunsen flame, in which is inserted a piece of asbestos soaked in a salt solution, or a ground glass plate illuminated either by a helium lamp operated on a 5000-volt ac circuit, or by a mercury vapor lamp covered with a green glass screen. The wave lengths of the most effective visible radiation from these sources are approximately:

Sodium (yellow) = 0.589 micron (0.0000232 inch).

Helium (yellow) = 0.588 micron (0.0000231 inch).

Mercury (green) = 0.546 micron (0.0000215 inch).

A colored glass screen illuminated by an incandescent lamp or ordinary daylight may be used as a source if high precision is not

desired, but the light will not be sufficiently monochromatic to allow assignment of a definite value to the most effective wave length.

A very convenient instrument for illuminating the film and at the same time viewing the interference fringes on the film is one designed by Pulfrich⁸ and shown in Fig. 3. The light from a helium lamp *H* is focused upon a small total reflection prism *p*. After being collimated by the lens *O*₁ it is reflected by the prism *R* down to the interferometer *ABD*, which is in the focal plane of the lens *O*₁. The rays reflected by the film surfaces are brought to a focus by the lenses *O*₁ and *O*₂ upon the slit *S*, and images of the interference pattern and the reference marks on the test plate are viewed with the eyepiece *C*. The direct-vision prism *K* separates the fringe patterns due to the helium light of different wave lengths. A pair of cross wires located at *S* and operated

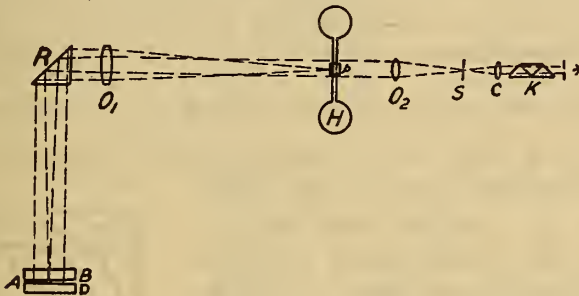

FIG. 3.—Optical system of the Pulfrich instrument

by a micrometer head make it possible to measure small displacements of the fringes from the straight reference lines ruled on the test plate *AB*. With this instrument and an exceedingly true test plate the planeness of an unknown surface can be measured with an accuracy of 0.025 micron (0.000001 inch). The only objection to the instrument is that the field is limited to about 2.5 cm (1 inch), so in testing a large surface only a small portion can be seen at one time. Instruments of similar optical design described by Schultz⁹, Schönrock¹⁰, and Laurent¹¹ eliminate this objection by having fields of view as large as 25 cm (10 inches). With these four instruments the rays of light coming from the source to the film surfaces are made parallel by the lens systems and when reflected back to the eye pass along the perpendicular

⁸ Pulfrich, *Zeits. f. Inst.*, 18, p. 261; 1898.

⁹ Schultz, *Zeits. f. Inst.*, 36, p. 252; 1914.

¹⁰ Brodhun and Schönrock, *Zeits. f. Inst.*, 22, p. 355; 1902.

¹¹ Laurent, *C. R.*, 96, p. 1035; 1883.

to, say, the first surface, and this condition holds over the whole field of view. Under such conditions, in equation (1) $\cos \theta = 1$, and

$$2t = N\lambda, \quad (3)$$

which states that the difference in path of the two interfering trains is simply equal to the double thickness of the film (the double distance signifying that the light travels down and back through the film). From this equation it is evident that where N is constant—that is along any one fringe— t is also constant. Hence, the fringes trace lines of equal separation of the two surfaces.¹² Starting from the line of contact AB of the two

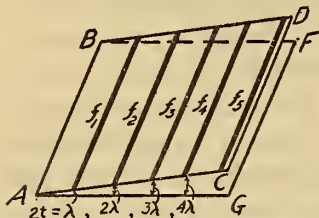

FIG. 4.—Interference fringes, plane surface

plane surfaces, Fig. 4, and moving to a wider part of the film, when $2t = \lambda$ interference occurs causing the first dark fringe f_1 which is a straight line parallel to AB . When $2t = \frac{3}{2}\lambda$, the wave trains reinforce each other and a bright fringe is produced. Moving to a still thicker part of the wedge, where $2t = 2\lambda$, a second dark fringe f_2 will occur, etc. From this it is evident that if the surfaces are plane the fringes will be straight lines, equally spaced, and parallel to the line of intersection of the surfaces. The next dark fringe always occurs on passing to where the double separation increases by λ . Hence, the distance between fringes depends on the inclination of the surfaces.

If a plane surface be brought in contact with a convex spherical surface, Fig. 5, then at C the point of contact $2t$ is equal to zero. Radially from this point the separation of the surfaces increases uniformly in all directions, so the fringes, and hence the lines on which $2t = N\lambda$, are concentric circles around the point of contact as a center. On any ring the distance of the spherical surface

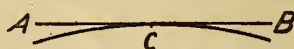
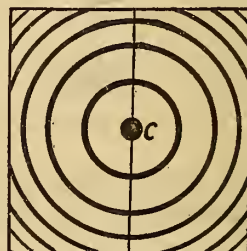

FIG. 5.—Interference fringes, convex spherical surface

¹² The fact should be stressed here, however, that the fringe marks the line of constant thickness of the film only when the direction of view is perpendicular to the film over the whole film. Observed obliquely, straight fringes do not indicate that the tested surface is plane, as shown below.

from the plane is equal to the number of the ring, counting from the point of contact, times $\frac{\lambda}{2}$. By pressing down at *A* the plane surface can be made to roll on the spherical surface, shifting the point of contact and with it the center of the ring system in the direction of *A* or toward the point of application of the pressure. With a convex surface, therefore, the center of the ring system lies at the point of minimum separation.

If one of the surfaces be concave and spherical, Fig. 6, a similar system of concentric circular fringes is produced, but in this case the center of the system lies at the point of maximum separation. Pressing down on *A* causes the center of the ring system to shift toward *B*, the direction of increasing separation, away from the point of application of the pressure. Thus, a slight pressure on one edge of the plane surface *AB* serves to indicate whether the curved surface is convex or concave.

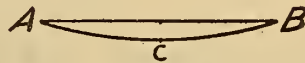
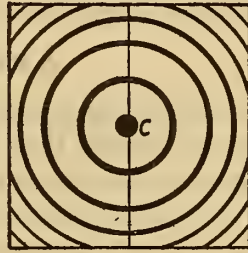

FIG. 6.—Interference fringes, concave spherical surface

With one surface plane and the other irregular the fringes are irregular, each of which follows the line of equal separation of the surfaces. Whether the irregularity is a projection or depression can be determined by applying a slight pressure to one edge of the upper surface and noting the direction of shift of the fringes.

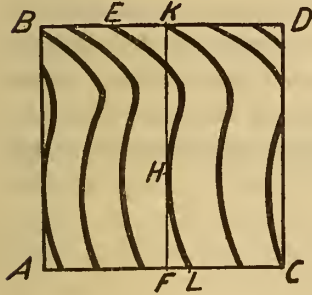

FIG. 7.—Interference fringes, irregular surface

The amount a curved surface deviates from a true plane can be readily estimated as follows: Draw a straight line *FK*, Fig. 7, across the center of the true plane surface, parallel to the line of contact *AB* of the surfaces. Bring this line tangent to one of the fringes at, say, the point *H*. It is

evident that this line represents the direction a fringe through *H* would take if the irregular surface could be converted into a plane tangent to the irregular surface at *H*. The fractional

part of the distance between two fringes by which the fringe EL deviates from the straight line FK gives the fractional part of a half wave length by which the irregular surface deviates along FK from true plane. With AB as the line of contact, the point F is estimated to be one-fourth wave length above and K one-half wave length below the plane surface tangent at H .

2. ERRORS OF INTERPRETATION

Although the theory is quite explicit, it is a very common mistake to assume that straight fringes always indicate planeness when a surface under test is placed on a true plane, and conversely curved fringes indicate that the surface is not a true plane. Both of these interpretations may be wrong. For example, the operator

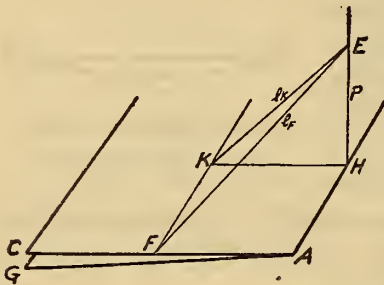

FIG. 8.—Errors of interpretation caused by viewing the film obliquely

may view the light reflected obliquely by the film, and to make sure that the fringes are straight he may lower his eye to sight along them. Or, the fringes from one position appearing curved, he may shift to another and find them quite straight, then draw his conclusions from what he observes under these, to him, best conditions.

It is important to know something about the magnitude of the errors which may be introduced by the assumption that straight fringes always indicate planeness and curved ones indicate curvature of the surface tested. The treatment of this falls under the general case shown in Fig. 2, where the thickness of the film at any point is given by equation (2)

$$t = \frac{N\lambda}{2} \frac{l}{P}, \quad (2)$$

which goes, for normal incidence, into equation (3)

$$t = \frac{N\lambda}{2}. \quad (3)$$

Suppose from the point E , Fig. 8, a straight fringe is observed along FK which is drawn parallel to AH . With one of the film surfaces plane, how much does the other diverge from plane

between F and K ? Using (3) instead of (2) in determining the thickness of the film at any point gives

$$t' = \frac{N\lambda}{2} \tag{4}$$

The error introduced is

$$t - t' = t' \left(\frac{l}{P} - 1 \right) \tag{5}$$

The actual deviation from planeness between F and K is

$$\Delta t = t_F - t_K \tag{6}$$

The observed deviation from (3) is

$$\Delta t' = t'_F - t'_K \tag{7}$$

The error introduced by using (3) instead of (2) is

$$S = \Delta t - \Delta t' = \left(\frac{l_F}{P} - 1 \right) t'_F - \left(\frac{l_K}{P} - 1 \right) t'_K = \left(\frac{l_F}{P} - 1 \right) \Delta t' + \frac{t'_K}{P} \Delta l \tag{8}$$

Where $\Delta l = l_F - l_K$.

This equation is seen to be consistent in that S becomes zero for normal incidence at both F and K , in which both $\left(\frac{l_F}{P} - 1 \right)$ and Δl are zero.

Sighting along a line from a normal position over K , $l_K = P$;

$$S = t'_F \left(\frac{l_F}{P} - 1 \right),$$

which states that the error in determining how much the tested surface deviates from the plane is simply equal to that in determining the thickness of the film at F , equation (5).

If one observes the fringe obliquely at both F and K , l_F and l_K increasing and at the same time approaching equality, we have for a given length FK the error represented by the term that contains $\Delta t'$, increasing with θ , while that represented by the term containing t'_K is decreasing. Take some numerical examples:

(a) With the eye 10 inches above the center of a 6-inch surface being tested on a true plane and viewing a diametrical fringe, $P = 10$, $l_F = 10.445$, $l_K = P$, applying (8)

$$S = 0.044 \Delta t' + 0.044 t'_K.$$

(b) With the eye moved back 10 inches in a direction at right angles to the fringe, P remaining constant, and viewing the center K and the farthest edge F , $l_F = 14.46$ $l_K = 14.14$ we have from (8)

$$S = 0.446 \Delta t' + 0.032 t'_K.$$

(c) With the eye moved back 20 inches instead of 10, $l_F = 22.56$, $l_K = 22.36$,

$$S = 1.256 \Delta t' + 0.020 t'_K.$$

A comparison of (a), (b), and (c) shows that the error arising from the actual deviation in planeness increases rapidly with oblique inspection, while the error rising from the thickness of the film decreases. Both these effects cause the fringes to straighten with increasing θ . Therefore, using oblique incidence slightly reduces the error of measurement if the surface under test is plane and greatly increases the error if the surface deviates from plane. An improvement on the customary apparatus is made by the addition of a thin plate of glass P , set at an angle of 45 degrees to the perpendicular EH from the eye to the surface, Fig. 9. With this arrangement the error due to deviation of the surface from plane is eliminated and a correction can be applied for error due to the film thickness.

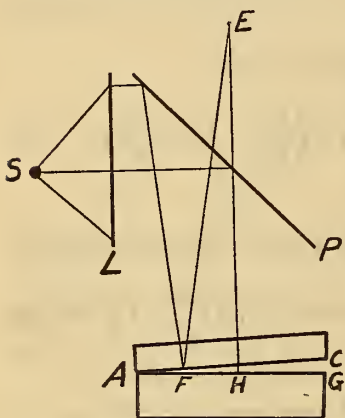

FIG. 9.—Optical system for testing surfaces

V. ADHERENCE OF SURFACES

When the plane surfaces of two gages, or of a gage and a glass plate, are brought into intimate contact, they adhere to each other, necessitating considerable force to separate them. To cause this adherence the surfaces are first washed with benzol, then with alcohol, and finally wiped with clean cotton to remove all traces of grease and dust. The surface of the plate is brought in contact with the gage surface and pressed on tightly to force out the film of air. A drop of alcohol when placed on the plate against the gage will spread out around the gage and pull the two surfaces into very close contact. Any excess of liquid can be forced out by sliding the surfaces on each other. When they

come into close contact the adhesive force causes them to grip each other and resist a large separating force.

A large number of measurements we have made show that when two very plane surfaces are brought into contact in this manner the separating film is not more than 0.025 micron (0.000001 inch) thick. Doubtless the surfaces come into intimate contact at the high points, the liquid filling the fine furrows or scratches left by the finishing laps. Our tests show that two gages with the ordinary lapped finish when brought into contact as described require to separate them a pull in the direction perpendicular to the surfaces of from 2.5 to 2.8 kg, per square centimeter (35 to 40 pounds per square inch).

With gages possessing a high optical polish more intimate contact is possible—that is, the capillary film is much thinner—and the required separating force ranges between 6.7 to 7 kg. per square centimeter (95 and 100 pounds per square inch). Considering the extreme thinness of the separating film when good contact exists, the need of exceedingly plane surfaces is apparent. A nick or burr on the edge or a small surface elevation which holds the two surfaces 0.25 micron (0.00001 inch) apart makes adherence almost impossible. Two surfaces will also adhere when covered with a film of grease or with moisture from the hand. The thickness of these films, however, is a rather indefinite quantity, in most cases about 0.07 micron (0.000003 inch), and while considerable force is required to slide the gages on each other they can be pulled apart by a force of 5 to 10 pounds per square inch. With gages having slight surface imperfections the oil film assists somewhat in holding them together and for the ordinary uses of gages the existence of the oil or grease film introduces no appreciable error, but in making accurate calibration of the gages themselves it should be eliminated.

The results obtained with two different combinations of gages are given in Table 1 to illustrate the effect produced by the film between the gages. The five gages in the first set were brought into contact as described above. The measured length of the combination differed from the sum of lengths of the individual gages by four millionths of an inch. The nine gages in the second set were first brought into contact as described above. In this case the measured length of the combination A differs from the sum of the lengths of the individual gages by six millionths of an

inch. The gages were then separated, rubbed across the wrist, and brought into contact again. The measured length B shows that the length of the combination increased by thirty-four millionths of an inch. This indicates that a film of moisture about three to four millionths of an inch in thickness had been introduced between each pair of gages.

TABLE 1.—Comparison of the Measured Lengths of Gage Combinations

Designation of length	Inches
Gages 0.30+0.25+0.20+0.125+0.120 Inch:	
Sum of individual lengths.....	0.995011
Measured length of combination.....	.995015
Gages 0.15+0.25+0.30+0.35+0.40+0.45+0.55+0.60+0.90 Inch:	
Sum of individual lengths.....	4.000079
Measured length of combination A.....	4.000073
Measured length of combination B.....	4.000107

VI. TEST FOR PARALLELISM OF SURFACES

The arrangement of the apparatus used to test the parallelism of the surfaces of a standard gage is shown in Fig. 10. Two

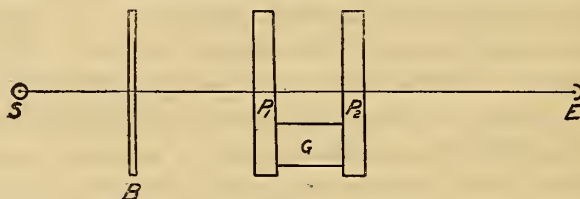

FIG. 10.—Optical system for testing parallelism of gage surfaces

accurately plane interferometer plates P_1 and P_2 have a semi-transparent film of platinum on their inner faces. Near one edge of each a strip of the platinum about one-half inch wide is removed. This clear area on P_1 is brought in contact with one end of the gage, G , and that of P_2 with the other end of the gage. This combination of plates and gage constitutes a Fabry and Perot interferometer. When this interferometer is placed in front of the ground glass screen B illuminated with monochromatic light from the source S , and viewed from E along a line SE perpendicular to the platinized surfaces, concentric interference rings known as "Haidinger rings" are seen. When the eye E is moved in a direction perpendicular to the line of sight SE , the system of rings moves across the plates in the same direction, the center of the system always remaining on the perpendicular from the eye

to the surface. If, now, the interferometer surfaces are parallel to each other, which means that the two gage surfaces which are in contact with them must also be parallel, each ring will retain its original diameter when the eye is moved as designated. If the plates are not parallel, the rings expand on moving opposite points of greater separation and contract as the eye is moved in the direction of smaller separation. Suppose that when the eye is shifted, so that the center of the ring system moves across the plates from one edge to the other, the first central ring expands and takes the place originally occupied by the second (a new ring forming within); then the distance between the two interferometer plates has increased by one-half wavelength, which for yellow helium light is about 0.29 micron (0.000011 inch). If the width of the gage is one-fourth that of the platinized space, this would mean a difference of about 0.07 micron (0.000003 inch) between the gage lengths along opposite sides. Since an expansion of

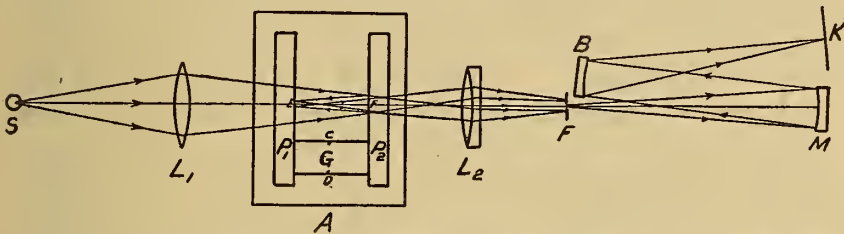

FIG. 11.—Optical system for determining the length of a gage by means of light waves

the rings can be estimated to one-fourth of the diameter of the first ring, an error of 0.025 micron (0.000001 inch) in the parallelism of the gage surfaces can be detected. To realize this precision, however, special care must be taken to have the surfaces of the gage in very close contact with the plates.

VII. CALIBRATION OF END STANDARDS WITH THE FABRY AND PEROT INTERFEROMETER

1. GENERAL PLAN OF APPARATUS

The arrangement of the apparatus used to measure gages in wave lengths is shown in Fig. 11. The interferometer formed by the gage and plates of Fig. 10 is placed within a constant temperature chamber *A* in front of the slit of a grating or prism spectrograph. Light from the neon lamp *S* is focussed by the lens *L*₁ upon the interferometer *P*₁*P*₂. Part of the light is transmitted directly through the interferometer, part is reflected by the

platinized surface of P_2 to the platinized surface of P_1 , where it is again partially reflected, and then a part of it passes on through P_2 , and so on through a large number of multiple reflections and transmissions. The reflected and directly transmitted parts when combined produce a system of interference rings which is focussed by the lens L_2 upon the slit F of the spectrograph. The images of the slit corresponding to the different radiations from neon are separated by the grating B and recorded on the photographic plate K .

2. SOURCE OF LIGHT

The source of light used in this work was an electric discharge tube filled with neon gas and operated on a 10 000 volt ac circuit. Wave lengths between 0.58 and 0.70 micron (0.000023 and 0.000028 inch) were used in making the determinations. The radiations from neon gas are very homogeneous and show good interference with large path differences, making it possible to measure gages 5 cm (2 inches) in length without difficulty. Longer gages can be measured if a telescope is used in making the interferometer adjustments. A limit on the maximum length of gage which can be compared directly with light waves by this interference method is imposed by the fact that no spectral lines are ideally homogeneous or monochromatic. Under ordinary conditions the neon lines fail to show interference when the retardation exceeds 300 000 waves. This permits direct comparison with 10 cm gages. The spectral lines of krypton are sharper and would allow 20 cm gages to be measured by this method.

3. INTERFEROMETER

The interferometer plates were glass disks 42 mm (1.7 inches) in diameter and 8 mm (0.3 inch) in thickness, or glass plates 5 cm (2 inches) square and 1 cm (0.4 inch) thick. These plates were covered with thin platinum films by the method of sputtering from a platinum electrode in a vacuum. Bringing a gage in contact with the platinum film causes the film to scale off, making adherence impossible. To eliminate this difficulty, a strip of the platinum a little larger than the gage surface was removed from each plate and the gage surface brought into contact with the clear glass surface. The gages which formed the separators or étalons for the interferometer plates varied in length from 1 mm to 5 cm and from 0.05 to 2 inches.

4. CONSTANT-TEMPERATURE CHAMBER

Since the length of a gage varies with the temperature, it is necessary to measure and specify the length at 20° C, which has been chosen as the standard temperature for measuring instruments. This was accomplished by placing the interferometer in a chamber *A* surrounded by a thermostated bath previously described.¹³ The temperature of the bath was brought to the desired point and held for a period of at least one-half hour before beginning the photographic exposures in order to allow the gage to assume a steady state.

5. SPECTROGRAPH

Dispersing apparatus of some kind is required in order that length measurements may be made with various colors or spectral lines such as are emitted by luminous neon gas. For this purpose either a prism spectrograph or a diffraction grating may be used, but the concave grating mounted in parallel light with the aid of a mirror has certain advantages in stability, achromatism, and minimum astigmatism over any other type of spectrograph which might be considered as suitable for these measurements.

For most of the work the grating spectrograph of the spectroscopic laboratory was used. *M* is a speculum concave mirror and *B* a concave grating. The mirror and grating each have a radius of curvature of about 640 cm. (21 feet). The grating was ruled by Dr. Anderson and has 39 800 lines on a distance of 13.2 cm. (5.2 inches). The linear dispersion at *K* with this apparatus is about 10 Å per millimeter in the spectrum of the first order.

6. PHOTOGRAPHIC

The spectrum of neon between the wave length limits 0.58 and 0.70 micron (0.000023 and 0.000028 inch) was recorded on Seed 27 photographic plates after staining with pinacyanol.¹⁴ The exposure times ranged from 5 to 10 minutes. Since the slit was illuminated by radiations, each of which produced a system of interference rings, the photograph of the spectrum shows the images of the slit crossed by arcs of the ring systems. The diameters of the interference rings were measured by means of a micrometer screw with a head graduated to 5 microns. By substituting a micrometer eyepiece for the photographic plate visual observations could be made on the diameters of monochromatic

¹³ Meggers and Peters, B. S. Sci. Papers, No. 327, p. 713; 1918.

¹⁴ Meggers and Stimson, J. Op. Soc. Am., 4, No. 3; 1920.

fringes, but a photographic impression of the interference phenomena is generally to be preferred.

7. DETERMINATION OF THE ORDER OF INTERFERENCE

Neglecting here any difference in phase change by reflection at the surfaces (treated in section 9) the thickness of the air space between the two interferometer plates is given by the equation

$$\begin{aligned} t &= \frac{N\lambda}{2} \\ &= (n + n') \frac{\lambda}{2}, \end{aligned} \quad (9)$$

where N is the order of interference at the center of the ring system, n that of the first ring, and hence n' the fraction difference in order between the first ring and the center of the system. In carrying out the computations n' is calculated as the fraction part of the order by which any given ring differs from N . The formula for calculating this is given by Meggers¹⁵

$$n' = \frac{n\omega^2 d^2}{8r^2}, \quad (10)$$

where d is the diameter of any given ring image, r the corresponding length of the image of a stop placed across the slit, and ω the angle subtended by this stop at the lens, L_2 , which projects the ring system on the slit. It is obvious that the approximate value of n obtained by using the nominal length of the gage which separates the plates is sufficient for calculating the value of n' .

The exact value of n is obtained as follows: If T be the nominal length of the gage, the approximate value of n is, for any given wave length,

$$n_1 = \frac{2T}{\lambda_1}.$$

From this

$$n'_1 = \frac{n_1 \omega^2 d^2}{8r^2},$$

which, together with n_1 , gives a tentative value T_1 for the thickness. This value T_1 is then used to calculate the trial value $N_o = n_o + n'_o$ of the order for each wave length used. From these approximate values of n and the measured diameters of the rings, n' for each wave length is obtained by substitution in (10). We

¹⁵ Meggers, B. S. Sci. Papers, No. 251; 1915.

now have two values for the fraction part of the order—one, n' , obtained from the measured diameter of the rings, and the other, n'_c , from the trial thickness of the gage. If these magnitudes coincide for the various wave lengths within the limits of experimental accuracy, it shows that n_1 has been correctly chosen. Otherwise n_1 must be corrected by some whole number, y , which may be determined as follows:

Let $R = \frac{\lambda_1}{\lambda}$ be the ratio of the wave length used for obtaining the trial value to the wave length being used to correct it. Since changing n_1 by the whole number y changes N for a wave length λ by Ry , and hence n' by $(1 - R)y$, we have the difference between the observed and calculated values

$$n' - n'_c = (1 - R)y,$$

from which

$$y = \frac{n' - n'_c}{1 - R}.$$

This serves to calculate for λ_1 a value t_1 for the thickness, which is subject only to the errors of measurements, not to the inaccuracy in the nominal length of the gage.

$$t_1 = \frac{\lambda_1}{2} (n_1 + y + n'_1).$$

From this corrected thickness the order of the first ring is readily computed for each wave length. These values of n and the computed fraction n' are then substituted in (9). Each wave length thus furnishes independently a value for t , from which the mean value is finally obtained.

8. CORRECTION OF λ

The wave lengths which are given for standard conditions of 15° C and 760 mm pressure vary with changes in the density of the air. The wave lengths must therefore be corrected to the existing temperature and pressure conditions. Since this correction and the dispersion of the air are small, it is sufficient to apply the correction factor

$$f = \frac{\mu_{15}}{\mu_t}, \text{ where } \mu_t = 1 + \frac{(\mu_{15} - 1) P}{760 T},$$

to the mean value of the thickness t , given above, to obtain the optical thickness t_p of the space at EF between the two platinum films.

9. CORRECTION FOR THE THICKNESS OF THE PLATINUM FILMS

With unplatined interferometer plates the distance t_g (at EF , Fig. 11, between the two glass surfaces as computed above from measurements of the rings would be the true distance between the plates, because the phase change of π due to the two air-glass reflections is eliminated in the determination of n . With the platinized surfaces, however, t_g differs from t_p by a small correction $x = t_g - t_p$, which is equal to the thickness of the films plus or minus the change in the optical path due to the difference in phase change for air-glass and air-platinum reflections. To measure x , a glass test plate is placed over each interferometer plate so as to cover both the clear and platinized parts. Each gives a system of fringes arising from the interference between the front and back surfaces of the thin air films inclosed. The system over the platinized area, owing to the combined effect of difference in thickness of the air film and difference in phase change by reflection, is displaced (less than one order) relative to the system from the clear portion. Multiplying by $\frac{\lambda}{2}$ the combined displacement resulting at the two plates, when tested with the light in the same direction as under working conditions, gives the correction x to be applied to the thickness of the gage as calculated in section 8.

10. CORRECTION FOR NONPARALLELISM OF THE GAGE SURFACES

If the gage surfaces are parallel, the interferometer plates will be parallel, and the length L of the gage is

$$L = t_g = t_p + x.$$

If the gage surfaces are not parallel, a correction must be applied to t_g to obtain L . Having the difference $z = L_C - L_D$ in the length of the gage along the two opposite sides C and D , Fig. 11, obtained as explained in section VI, and making the distance from EF to the gage at C equal to the width of the gage, the length along C is obviously

$$L_C = t_g - z,$$

and along D is

$$L_D = t_g - 2z.$$

11. COMPUTATIONS

An illustration of the method for making the computations for a 25.4 mm (1 inch) gage is shown in Table 2. Column 1 gives the wave lengths used; 2, the measured diameter d of the first and second rings, respectively; 5, the fractional part n' of the order at the center of each ring system; 6, the order of interference N or number of waves in the double distance between the plates at the center of the ring $N = n + n'$; and 7, the double optical thickness of the air film or $N\lambda$.

TABLE 2.—Computing Method for a 25.4 mm Gage

1 λ in Angstrom units	2 ^a d	3 d^2	4 $\frac{d^2 \omega^2}{8r^2}$	5 n'	6 N	7 $2t$ in microns
5852.488.....	455 676	207 457	93 205	0.807 1.779	86 802.793	50 801.2304
5944.834.....	341 602	116 362	52 162	.444 1.384	85 454.414	50 801.2306
6096.163.....	551 746	304 557	136 205	.133 1.083	83 333.108	50 801.2210
6143.062.....	495 713	245 508	110 228	.910 1.885	82 693.898	50 801.2254
6334.428.....	409 667	167 445	75 199	.601 1.596	80 199.599	50 801.2251
6506.528.....	295 612	87 375	39 168	.304 1.312	78 077.308	50 801.2191
6678.276.....	344 631	118 398	53 178	.403 1.354	76 069.379	50 801.2308
$f=1.0000102$						
Mean value of $2t$						50 801.2261
Corrected for density of air, $2t \times f = 2t_p$						50 801.7442
Correction for film thickness, z						25 400.8721 .0701
Distance between glass plates, t_g						25 400.9422
Correction for slant of gage surface, $-z$0367
Length of gage at C, L_c						25.4009789 mm
Length of gage at D, L_D						1.0000365 inch 25.4010156 mm 1.0000380 inch

^a In columns 2 to 5, the figures in each group of two refer, respectively, to the first and second rings.

12. ACCURACY AND SOURCES OF ERROR

A comparison of the values obtained for the thickness of the air film, Table 2, column 7, shows that the maximum variation of t for the several wave lengths is about one part in five million when using a 1-inch separator. The correction for the change in λ arising from a change in density of the air is about one part in one hundred thousand. With the accurate values of the refractive index of air¹⁶ available, this correction should not introduce an

¹⁶ Meggers and Peters, B. S. Sci. Papers, No. 327; 1918.

error of one part in ten million in the total length. The combined thickness and phase difference effect of the platinum films is about 0.07 micron (0.000003 inch), and the probable error in measuring this thickness about 0.003 micron (0.0000001 inch), which would introduce an error in the value of the distance between the plates of about one part in ten million. Therefore, using a 25 mm (1 inch) étalon and making measurements with several wave lengths, the value of the distance t_g between the glass surfaces at EF should be correct relative to the International meter to about 1 part in four or five million.

Transferring this measured distance to the gage introduces the greatest error. With a perfect gage and perfectly plane interferometer plates the only sources of error are the films between the gage surfaces and the plates. If the surfaces are thoroughly cleaned and carefully brought into contact, the separation is less than 0.025 micron (0.000001 inch). It is probable that slight projections on the surfaces are in intimate contact and that the liquid film exists in the intervening spaces. Therefore, with carefully controlled conditions, the error in the measurement of perfect gages should be less than 0.025 micron (0.000001 inch).

In actual practice, however, most interferometer plates obtainable deviate from true plane by about 0.05 micron (0.000002 inch), and the surfaces of carefully selected gages deviate from true plane and parallelism by about 0.13 micron (0.000005 inch) on the average. Therefore, in transferring t_g to the gage the error introduced depends largely upon imperfections of the gage. With carefully selected gages the errors in the values of the length along the C and D sides range from 0.025 to 0.075 micron (one to three millionths inch).

The measurements made on one of our standards (1-inch, set 7) shown in Table 3 are representative of the values obtained for several hundred other standards. Each value given is the result of a single determination made after a separate assembling of the interferometer and adjustment of the spectrograph. The first determination of January 11, 1921, was made with the grating spectrograph shown in Fig. 11. The second determination of that date was made with a different pair of interferometer plates and a prism spectrograph.

TABLE 3.—Length of 1-Inch Gage of Set 7 at 20° C

Date	Length	Date	Length
	Inches		Inches
Feb. 4, 1918.....	1.000008	Feb. 7, 1918.....	0.9999992
Feb. 7, 1918.....	.9999996	Mar. 17, 1920.....	.9999983
Do.....	.9999990	Jan. 11, 1921.....	.9999974
Do.....	.9999993	Do.....	.9999968

Another very important source of error that may be overlooked is the thermal expansion of the material. A 25 mm (1-inch) length of steel expands about 0.32 micron (0.000013 inch) per degree Centigrade rise in temperature. The gage must therefore be held at the constant temperature of 20° C within a few hundredths of a degree. If the measurements are made at any other temperature, this must be accurately measured and the expansivity of the material known in order to reduce the length to standard conditions. We have found expansion coefficients ranging from 0.000011 to 0.000013 for gage steels of various compositions, hardness, and previous heat treatment. This shows that it is unsafe to assume a value for the expansivity when measuring the absolute length of a gage or comparing an unknown gage with a standard at a temperature that differs very much from 20° C.

TABLE 4.—Thermal Expansion of Several Precision Gages

Gage	Temperature interval	Coefficient of expansion ×10 ⁴	Gage	Temperature interval	Coefficient of expansion ×10 ⁴
	°C			°C	
Johansson, set 5813, 10 mm..	20 -50	0.129	Bureau of Standards:		
Do.....	20 -50	.129	Steel A, 0.4 inch.....	24.0-76.9	0.132
Johansson, set 5813, 9 mm..	20 -50	.125	Steel B, 0.4 inch.....	33.0-82.8	.129
Do.....	20 -50	.125	Pratt & Whitney, 0.375 inch..	21 -78	.135
Johansson, set 20, 0.4 inch..	19.8-75.5	.124	Schuchardt and Schutte, 0.5		
Do.....	32.8-76.5	.123	inch.....	5.8-46.0	.116
Johansson, set 7, 0.4 inch..	56.3-79.6	.131	Do.....	5.8-46.0	.115
Do.....	19.6-79.6	.132			
Johansson, set 7, 0.35 inch..	21.3-82.4	.128			
Do.....	20.6-82.4	.127			

In Table 4 is shown the thermal expansion of several precision gages. These measurements were made with the interferometer and electrical furnace previously described in our publication ¹⁷

¹⁷ Peters and Cragoe, B. S. Sci. Papers, No. 393; 1920.

on the dilatation of optical glass. Column 1 gives the designation of the gage under investigation; column 2, the temperature interval; and column 3, the coefficient of expansion.

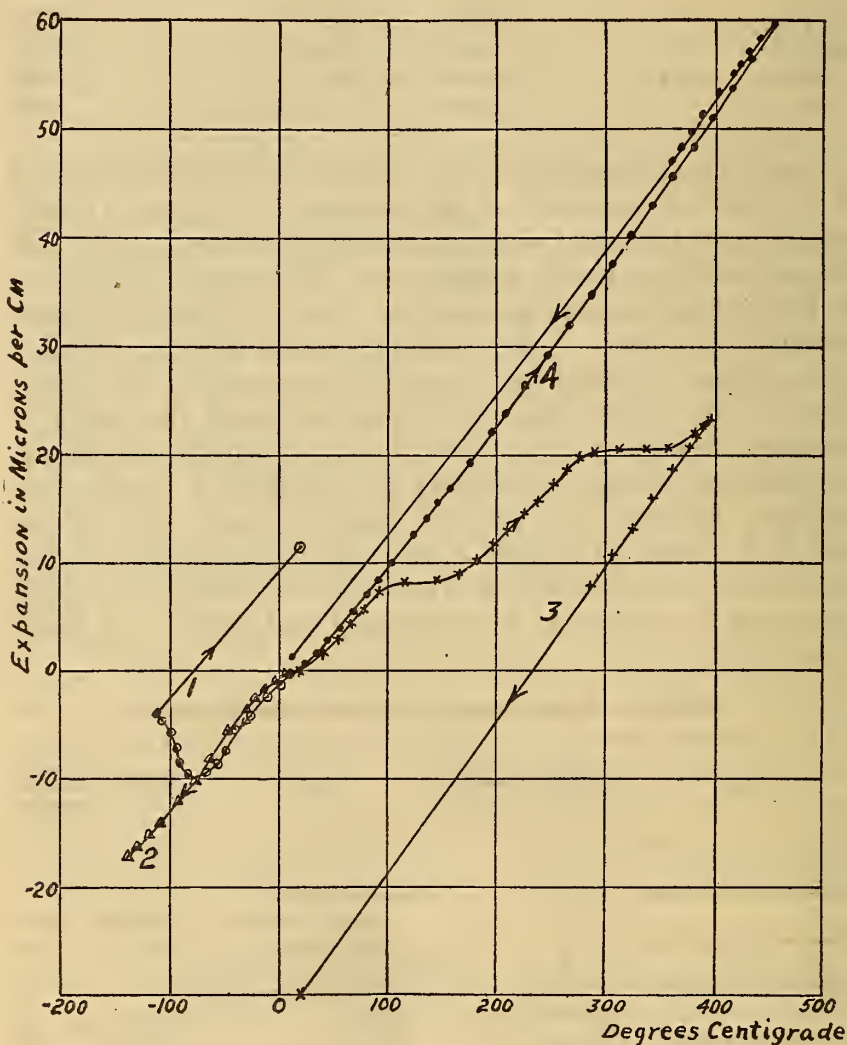

FIG. 12.—Curves showing the thermal expansion of the steel used for precision gages

The composition of steel B which is used for precision gages at the Bureau of Standards is C, 1.00 to 1.10 per cent; Mn, 0.30 to 0.40 per cent; P, 0.025 per cent; S, 0.025 per cent; Si, 0.20 to 0.30 per cent; Cr, 1.30 to 1.50 per cent; balance, Fe. This is almost identical with the compositions that have been published

for the steels used in the Johansson and the Pratt & Whitney gages.

The thermal expansion of a gage about 1 cm long and 2 cm in diameter made from steel B is shown in Fig. 12. It was hardened by heating to 850° C and quenching in oil. The original hardness was 95 as measured with a scleroscope, and length was 11.024 mm. The sample was first cooled to -114° C, the change in length being represented by curve 1. On returning to room temperature the hardness was 94.5 and the length 11.035 mm; that is, the length had increased 12 microns due to this treatment. After cooling again to -135° C, represented by curve 2, and returning to room temperature the hardness was 94 and length 11.035 mm. No further change in length took place. The sample was then heated to 392° C and allowed to cool to 20° C, change in length being represented by curve 3. The final hardness was 76 and length 11.004 mm. This treatment caused a permanent shortening of about 31 microns. The sample was then heated to 450° C and allowed to cool to 20° C. The change in length is represented by curve 4.

TABLE 5.—Changes of Length with Time

Gage	Date	Length	Gage	Date	Length
		Inches.			Inches.
1.000 inch.....	Mar. 1, 1919	1.000000	2.000 inches.....	Mar. 19, 1920	1.999993
	June 3, 1919	.999998		May 22, 1920	1.999992
	July 19, 1919	.999992	3.000 inches.....	Feb. 20, 1919	3.000000
	Aug. 19, 1919	.999992		Apr. 28, 1919	2.999975
	Oct. 16, 1919	.999993		Aug. 20, 1919	2.999900
	Mar. 20, 1920	.999988		Sept. 19, 1919	2.999877
	May 21, 1920	.999988		Mar. 18, 1920	2.999856
				May 21, 1920	2.999851
1.000 inch.....	May 21, 1919	1.000000	4.00 inches.....	Apr. 29, 1919	4.000000
	May 29, 1919	1.000018		June 2, 1919	3.999998
	June 17, 1919	1.000022		July 19, 1919	3.999992
	Aug. 19, 1919	1.000034		Aug. 19, 1919	3.999980
	Oct. 17, 1919	1.000038		Oct. 16, 1919	3.999980
	Jan. 7, 1920	1.000043		Mar. 18, 1920	3.999971
	Mar. 20, 1920	1.000044		May 21, 1920	3.999970
	May 22, 1920	1.000047			
2.000 inches.....	Mar. 1, 1919	2.000000	4.00 inches.....	May 7, 1919	4.000000
	May 29, 1919	1.999976		June 3, 1919	4.000014
	July 19, 1919	1.999966		Aug. 20, 1919	4.000025
	Aug. 19, 1919	1.999963		Nov. 26, 1919	4.000021
	Oct. 16, 1919	1.999951		May 21, 1920	4.000025
	Mar. 18, 1920	1.999938	4.00 inches.....	Dec. 22, 1919	4.000000
	May 21, 1920	1.999935		Mar. 18, 1920	3.999999
2.000 inches.....	Sept. 24, 1919	2.000000		May 21, 1920	3.999993
	Oct. 16, 1919	2.000002			
	Jan. 9, 1920	2.000000			

Unless the material from which the standards are made is exceedingly stable the high accuracy of the length determination is soon lost due to changes in the length with time. While we have found many steel gages that retain their dimensions remark-

ably well, others have been found to change several microns—or hundred thousandths of an inch—in a few months. A few examples of gages that have undergone changes of length with time are given in Table 5. The fact that these changes may take place requires frequent intercomparisons and redeterminations of the gages used as standards.

VIII. COMPARISON OF GAGES WITH STANDARDS

1. COMPARISON OF LENGTH

The accurate comparison of two gages, *A* and *B*, Fig. 13 (front), of supposedly the same length, is made by the following method:

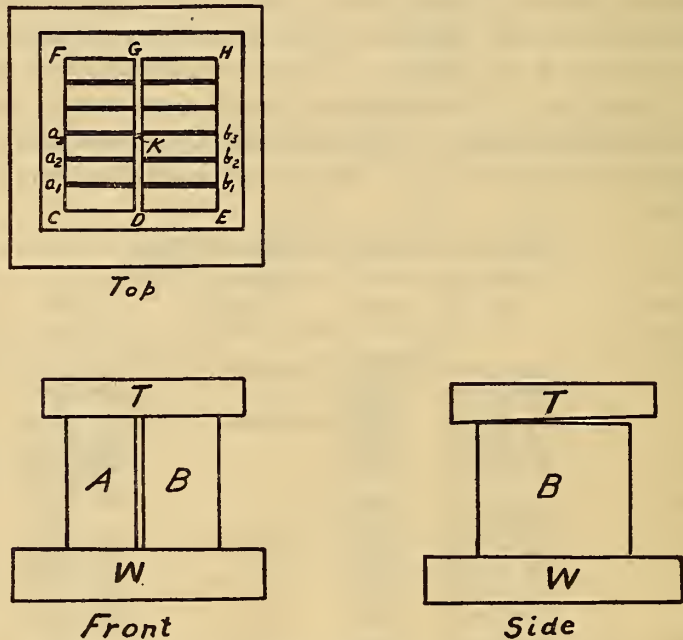

FIG. 13.—Intercomparison of two similar gages of equal length

The two gages are placed side by side in intimate contact, as described in *V* above, with the true plane surface of a glass plate *W*. The lower surfaces of the two gages being in the same plane, the problem is then simply to determine the distance between the planes of the two upper surfaces. This is done by placing a test plate *T* in contact with the gages along the line *CDE*, Fig. 13 (top), and somewhat inclined to these surfaces. This gives side by side two thin wedge-shaped films. When illuminated and viewed as shown in Figs. 3 or 9, two sets of straight fringes parallel

to the edge of the wedge are seen; see top view, Fig. 13. Since it is only necessary then to determine the difference in thickness of these films at some adjacent position, say K , we can assume zero phase changes at the surfaces and calculate the distance at that point between the planes of the two gage surfaces. If the two gages are of the same length, their upper surfaces will lie in the same plane, so when we pass to the thicker part of the wedge from the line of contact CDE , the first fringe a_1 on A will coincide with the first fringe on b_1 on B , the second with the second, etc.

Consider the point K , where there is coincidence between the third fringes on the two gages. For perpendicular view the optical thickness of the film at any point is given by equation (3)

$$t = \frac{N\lambda}{2}.$$

In this case the distance t from the test plate to each gage would be $\frac{3\lambda}{2}$ at K , which means that the gages are of equal length.

Suppose the gages are unequal in length, say B is shorter than A . The test plate will then come in contact with A at the point D and with B at the point E and the fringes appear, as in Fig. 14. If at K , we have the second fringe over A coinciding with the fourth over B , the distance at that point between the test plate and A is $\frac{2\lambda}{2}$ and between the test plate and B is $\frac{4\lambda}{2}$. Therefore,

the distance between the planes of the two gage surfaces is $\frac{2\lambda}{2}$. If

we are using a helium lamp for a source, $\frac{\lambda}{2}$ is about 0.3 micron (0.000012 inch), hence B is about 0.6 micron (0.000024 inch) shorter than A . If A is a calibrated standard, we immediately have the length of the unknown gage B . By estimating the displacement of the fringes to one or two tenths of the distance between two bands measurements of still greater refinement can be made. In making these measurements it is absolutely essential that the fringes be viewed with the Pulfrich or other instruments previously referred to, or as shown in Fig. 9; that is, normally to

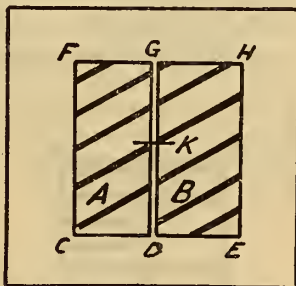

FIG. 14.—Intercomparison of two similar gages of slightly different length.

the gage surfaces. If they are viewed at an angle to the perpendicular, then the thickness is not equal to $\frac{N\lambda}{2}$, but equal to $\frac{N\lambda}{2} \frac{l}{P}$, so that an incorrect interpretation of the distances is made.

When observing with the unaided eye, as shown in Fig. 9, it is not advisable to make comparisons between gages that differ in length by more than five or six wave lengths. With the aid of the Pulfrich instrument, however, comparisons between gages that differ in length as much as $\frac{1}{2}$ inch may be made. With this method the fractional orders n' at the point K over each gage are measured for several different radiations of helium gas. The orders of interference N for each wave length are then computed from these fractions and the approximate distance between the test plate and the upper surface of each gage by the method described in Section VII, which holds for straight fringes as well as for Haidinger rings.¹⁸

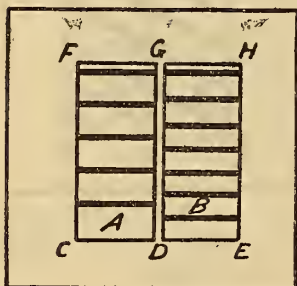

FIG. 15.—Test for parallelism of gage surfaces. B shorter at GH than DE

The absolute length of a gage is found in the same way. The gage is brought in contact with a steel base plate and the thicknesses of the air columns over the gage and base plate, respectively are measured. The distance between the test plate and the base plate minus the distance from the test plate to the gage gives the length of the gage. The steel base plate is used in order to eliminate any difference in phase losses on reflection. This method was used in calibrating most of the end standards less than 5 mm ($\frac{1}{2}$ inch) in length, because the operation of making the measurement and computations requires only about one-third the time consumed when using the circular fringe method.

2. COMPARISON OF PARALLELISM OF SURFACES

The test for parallelism of the two surfaces of an unknown gage B is made along with the length comparison. Assuming that the two surfaces of the standard gage A , Fig. 15, are plane and parallel, the test plate brought in contact with it along CD gives straight fringes over A which are parallel to CD and equally spaced. If the upper surface of the gage B is parallel to the plane of the upper surface of A , the fringes over B will be parallel to those over

A and have the same spacing. If, however, the length of B at GH is less than at DE, then the wedge over B will be steeper than over A and the fringes closer together. Therefore, if as indicated

7 fringes are observed over B and 5 over A, GH is $\frac{2\lambda}{2}$ below DE,

or the gage is about 0.000022 inch shorter on the GH side than on the DE side. If the length of B

at GH is greater than at DE, then the wedge over B will be thinner than over A and the fringes farther apart. If

the surfaces of the standard A are not parallel, then to determine the true slant or lack of parallelism of the surfaces of B along DG, the apparent slant is determined as described above.

Letting A_{FG} , B_{GH} , etc., also denote the lengths of the gages along those sides, we have $B_{GH} - B_{DE} = s$. If now from other sources it is known that the

slant of A is $A_{FG} - A_{CD} = a$, then the true slant of B is

$$b = a + s, \tag{11}$$

a, b, and s being positive or negative, as the case may be.

Suppose, as in Fig. 16, that the edge GD of B is parallel to the plane of the upper surface of A, but the surface of B slopes slightly, so that HE is above GD.

Since the fringes lie along lines of equal thickness of the air film, they will extend across B at an angle to those over A, being deflected toward the open end of the film or toward H.

If HE is below GD, the fringes on B will be deflected toward the thin edge of the film or toward E, as in Fig. 17. If we draw a line KL parallel to CE from the left end of any fringe over B, the displacement of the other end of that fringe

from KL divided by the distance between two consecutive fringes gives the difference in height between GD and HE in half wave lengths. This difference gives the slant between the upper surface of A and the upper surface of B. If the two surfaces of A are perfectly parallel, it is also the slant between the two surfaces of B. If the

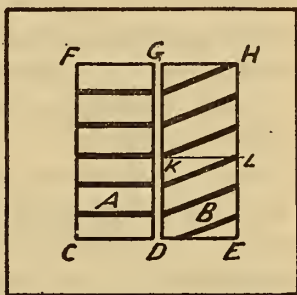

FIG. 16.—Test for parallelism of gage surfaces. B longer at HE than at GD

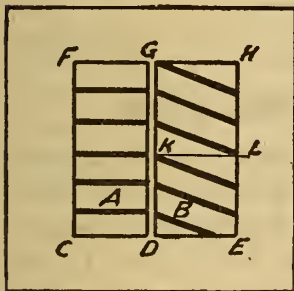

FIG. 17.—Test for parallelism of gage surfaces. B shorter at HE than at GD

from KL divided by the distance between two consecutive fringes gives the difference in height between GD and HE in half wave lengths. This difference gives the slant between the upper surface of A and the upper surface of B. If the two surfaces of A are perfectly parallel, it is also the slant between the two surfaces of B. If the

two surfaces of A are not parallel, but the slant $A_{GD} - A_{FC} = c$; using the same expression for length as above, then the true slant of B is equal to the observed apparent slant $B_{DG} - B_{HE} = d$ minus kc , where k is the ratio of the widths of the gages B and A ; that is,

$$f = d - kc. \quad (12)$$

The slant of the two surfaces of B can also be determined by measuring the perpendicular distances between them, say, at the middle points of all four edges of B , by bringing them successively contiguous to A at the point K .

When determining the length of a gage or standard with the Pulfrich instrument, the fringes over the gage should be parallel to and equally spaced with those over the base plate. Any deviation from such a condition signifies that the gage surfaces are not parallel, in which case the amount of nonparallelism may be determined by the method just described on making a and c equal to zero in the formulas (11) and (12).

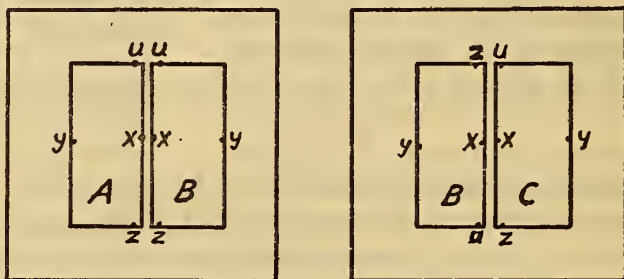

FIG. 18.—Test for relative length of gages and parallelism of the surfaces by the intercomparison of three similar gages

IX. INTERCOMPARISON OF THREE GAGES

The lack of parallelism of the two faces at each of three unknown gages, A , B , and C , can be accurately determined and an intercomparison between their lengths made by bringing them in contact with the base plate two at a time. Let A_x , B_x , C_x , A_y , etc., denote the lengths of the gages at the points x , y , z , u , indicated in Fig. 18, and

$$\begin{aligned} A_K &= A_u - A_z, & A_S &= A_x - A_y, \\ B_K &= B_u - B_z, & B_S &= B_x - B_y, \\ C_K &= C_u - C_z, & C_S &= C_x - C_y, \end{aligned}$$

represent, respectively, the slants of the gages A , B , and C in the two perpendicular directions uz and xy . If the gages A and B are brought into contact with the base plate, so that A_u and B_u ,

A_x and B_x , and A_z and B_z are adjacent, as in Fig. 18 (left) (gage A face up and B face down), then one can make the comparisons between the lengths of the gages:

$$\begin{aligned} A_u - B_u &= r,^{19} \\ A_z - B_z &= s, \\ A_x - B_x &= l, \end{aligned}$$

and observe the apparent slant $B_x - B_y = a$ on B . Gage B can then be replaced by C and a similar comparison made

$$\begin{aligned} A_u - C_u &= t, \\ A_z - C_z &= q, \\ A_x - C_x &= m, \\ C_x - C_y &= b \text{ (apparent slant)}. \end{aligned}$$

Then B replaces A , so that B_z and C_u , B_u and C_z , and B_x and C_x are adjacent (both gages face down), Fig. 18 (right). The final comparisons to be made are:

$$\begin{aligned} B_z - C_u &= v, \\ B_u - C_z &= w, \\ B_x - C_x &= n, \\ C_x - C_y &= c \text{ (apparent slant)}. \end{aligned}$$

Solving these twelve equations:

$$(1) \quad m - l = n$$

showing that this method gives a comparison of the lengths of the gages at the corresponding x-points, and a check on this comparison.

$$\begin{aligned} (2) \quad A_K &= r - q + w, \\ &= t - s - v, \\ B_K &= A_K - r + s, \\ C_K &= A_K - t + q, \end{aligned}$$

giving two determinations of the slant of each gage in the direction uz , the mean of which may be taken as the true value with an error of one-half an algebraic combination of the errors of the six measurements.

¹⁹ The small letters represent the measured quantities.

(3) If B and C are f and h times as wide as A , respectively, then C is $\frac{h}{f}$ times as wide as B and

$$\begin{aligned} B_s &= a - f A_s, \\ C_s &= b - h A_s, \\ C_s &= c - \frac{h}{f} B_s, \\ A_s &= \frac{f(b-c) + ah}{2fh}, \\ B_s &= \frac{f(c-b) + ah}{2h}, \\ C_s &= \frac{h(b+c) - ah}{2f}. \end{aligned}$$

If the gages are all the same width, then $f = h = 1$ and

$$\begin{aligned} A_s &= \frac{b-c+a}{2}, \\ B_s &= \frac{c-b+a}{2}, \\ C_s &= \frac{b+c-a}{2}, \end{aligned}$$

showing that the error of each determination is one-half the algebraic combination of the individual errors. Thus, the method of intercomparing three gages enables one to determine easily and accurately the relative merits of each, their planeness errors having been previously determined, so that the best one can be chosen as a secondary standard of length and the others as working standards for use in the laboratory.

X. DEVELOPMENT OF STANDARD GAGES

Having established the fact that two plane surfaces can be brought into contact, so that the separation is less than two hundredths of a micron (one millionth of an inch), and having the interference method for comparing two gages of nearly equal length, it is possible to calibrate long gages from line standards and make comparisons between these long gages and equal combinations of two or more shorter ones. The arrangements used by Fischer²⁰ and Perard²¹ for comparing a long end standard with a line standard are shown in Fig. 19. Two gages, A and B , are brought into close contact, and two fine lines, C and D , are ruled

²⁰ Phil. Soc. Wash., Bull., 13, p. 241; 1898.

²¹ C. R., 154, p. 1586; 1912.

on them parallel to their plane of contact, *EF*. The distance *X* between the lines *C* and *D* is determined by comparison with the line standard. *A* is then brought into contact with one surface of the long gage *G* which is to be calibrated and *B* with the opposite surface of *G*. The distance *Y* between the two lines *C* and *D* is

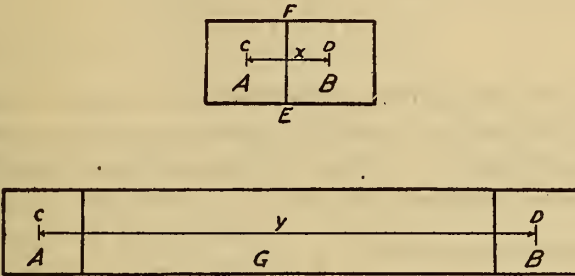

FIG. 19.—Calibration of end standards relative to line standards

again determined by comparison with the line standard. The difference in the two distances $Y - X$ gives the length of the gage *G* in terms of the line standard.

After the length of *G* has been accurately determined by comparison with the line standard or by direct measurement with the light waves, combinations of shorter gages can be compared with it by using the interference comparator, as follows: Suppose *G* is 6 inches long and we have three gages, *A*, *B*, and *C*, each very nearly 3 inches in length. *G* is brought into contact with the plane base plate *W*, Fig. 20, *B* is also placed in contact with *W*, and *A* with the upper surface of *B*. The difference *a* in the lengths of *G* and the combination of *A* and *B* is obtained from the relative displacement of the interference fringes as described in section VIII. The combined length of *A* and *B* is equal to that of *G* plus *a*. In the same way the observed difference *b* between the combined lengths of *B* and *C* and that of *G* is obtained. Likewise *c* for gages *C* and *A*. Letting the designation of the gages also represent their lengths, we have

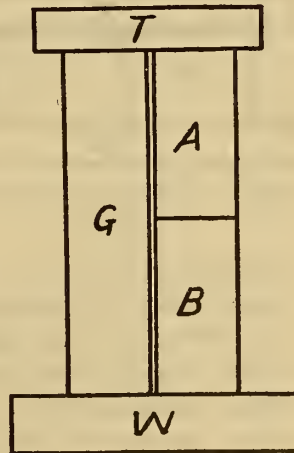

FIG. 20.—Comparison of two short gages with one long gage

$$\begin{aligned}
 A + B &= G + a, \\
 B + C &= G + b, \\
 C + A &= G + c,
 \end{aligned}$$

where G is the known length of the standard and a , b , and c are measured. These equations can be readily solved for the unknowns, A , B , and C . Similarly, with four gages, A , B , C , and D , each nearly 2 inches long, we would have

$$A + B + C = G + a,$$

$$B + C + D = G + b,$$

$$C + D + A = G + c,$$

$$D + A + B = G + d.$$

Since the four independent simultaneous equations contain four unknowns, the length of each unknown gage can be computed.

In general, given $n + 1$ unknown gages of nearly equal length, n of which when combined are nearly equal to the known gage G ,

there will be $n + 1$ combinations which may be compared with G . Hence, the length of each unknown gage can be obtained by this comparison method. Intermediate sizes may be measured by comparing the combined lengths of a known and unknown gage with a known.

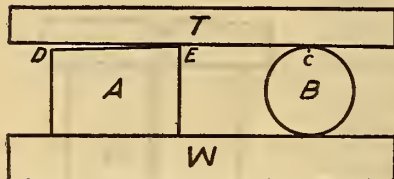
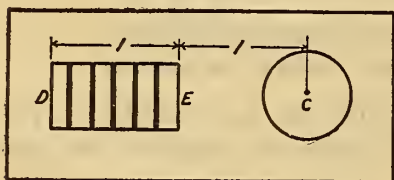

FIG. 21.—Comparison of a sphere with a gage block

XI. COMPARISON BETWEEN GAGES AND OTHER OBJECTS

An accurate determination of the dimensions of any body, say a sphere, can be made by comparison with a gage of nearly the same size. For this the gage A and the sphere B are placed in contact with the base plate W , Fig. 21, and the test plate T laid over them. If B is slightly smaller than A , the test plate will touch the gage along the edge E and the sphere at the point C . When illuminated and viewed as shown in Fig. 3 or 9, straight fringes parallel to E will be seen to cross the upper surface of the gage. The number of fringes N across the face of the gage from D to E multiplied by $\frac{\lambda}{2}$ gives the distance between the cover plate and the gage surface at D . If the distance CE is equal to DE , then the point C must be $\frac{N\lambda}{2}$ below the plane of the surface of the

gage, and hence the diameter of the sphere $\frac{N\lambda}{2}$ less than the length of the gage. If B is larger than A , the upper plate will touch the gage along the edge D and be $\frac{N\lambda}{2}$ above E . C would then be $\frac{2N\lambda}{2}$ above the plane of the surface of the gage and the diameter of B equal to the length of the gage plus $N\lambda$.

XII. SUMMARY

The extensive use of precision gages as reference standards for precise mechanical work has required more accurately determined end standards and more rapid and precise methods for comparing gages with these standards than have been previously available. Since comparison of end standards with line standards by means of micrometer-microscopes and of precision gages with end standards by means of contact instruments are subject to appreciable errors, methods which make use of the interference of light waves were used in making these measurements. With the interference methods described in this article, the planeness and parallelism errors of precision surfaces can be measured and the length of standard gages determined by direct comparison with the standard light waves with an uncertainty of not more than a few millionths of an inch. The errors of other gages can be determined by comparison with these calibrated standards with equal precision. This process makes the standard light waves which have been determined to one part in four or five million relative to the international meter, the standards of length for this work. Three sets of gages each containing 81 blocks were selected for end standards. These were tested for surface errors and calibrated by comparison with the light waves and have been recalibrated every few months because changes with wear or time are known to occur in material gages. Large numbers of precision gages have been compared with these end standards with sufficient speed and precision to meet all requirements.

WASHINGTON, May 3, 1921.





