

~~A11100 993499~~

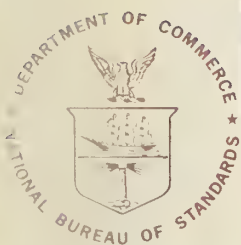

NAT'L INST. OF STAND & TECH



A11107 160398

# NBS TECHNICAL NOTE **950**

U.S. DEPARTMENT OF COMMERCE / National Bureau of Standards

## The NBS Detector Response Transfer and Intercomparison Package: The Instrumentation

QC  
100  
U5753  
No. 950  
1977  
c.2

## NATIONAL BUREAU OF STANDARDS

The National Bureau of Standards<sup>1</sup> was established by an act of Congress March 3, 1901. The Bureau's overall goal is to strengthen and advance the Nation's science and technology and facilitate their effective application for public benefit. To this end, the Bureau conducts research and provides: (1) a basis for the Nation's physical measurement system, (2) scientific and technological services for industry and government, (3) a technical basis for equity in trade, and (4) technical services to promote public safety. The Bureau consists of the Institute for Basic Standards, the Institute for Materials Research, the Institute for Applied Technology, the Institute for Computer Sciences and Technology, the Office for Information Programs, and the Office of Experimental Technology Incentives Program.

**THE INSTITUTE FOR BASIC STANDARDS** provides the central basis within the United States of a complete and consistent system of physical measurement; coordinates that system with measurement systems of other nations; and furnishes essential services leading to accurate and uniform physical measurements throughout the Nation's scientific community, industry, and commerce. The Institute consists of the Office of Measurement Services, and the following center and divisions:

Applied Mathematics — Electricity — Mechanics — Heat — Optical Physics — Center for Radiation Research — Laboratory Astrophysics<sup>2</sup> — Cryogenics<sup>2</sup> — Electromagnetics<sup>2</sup> — Time and Frequency<sup>2</sup>.

**THE INSTITUTE FOR MATERIALS RESEARCH** conducts materials research leading to improved methods of measurement, standards, and data on the properties of well-characterized materials needed by industry, commerce, educational institutions, and Government; provides advisory and research services to other Government agencies; and develops, produces, and distributes standard reference materials. The Institute consists of the Office of Standard Reference Materials, the Office of Air and Water Measurement, and the following divisions:

Analytical Chemistry — Polymers — Metallurgy — Inorganic Materials — Reactor Radiation — Physical Chemistry.

**THE INSTITUTE FOR APPLIED TECHNOLOGY** provides technical services developing and promoting the use of available technology; cooperates with public and private organizations in developing technological standards, codes, and test methods; and provides technical advice services, and information to Government agencies and the public. The Institute consists of the following divisions and centers:

Standards Application and Analysis — Electronic Technology — Center for Consumer Product Technology: Product Systems Analysis; Product Engineering — Center for Building Technology: Structures, Materials, and Safety; Building Environment; Technical Evaluation and Application — Center for Fire Research: Fire Science; Fire Safety Engineering.

**THE INSTITUTE FOR COMPUTER SCIENCES AND TECHNOLOGY** conducts research and provides technical services designed to aid Government agencies in improving cost effectiveness in the conduct of their programs through the selection, acquisition, and effective utilization of automatic data processing equipment; and serves as the principal focus within the executive branch for the development of Federal standards for automatic data processing equipment, techniques, and computer languages. The Institute consist of the following divisions:

Computer Services — Systems and Software — Computer Systems Engineering — Information Technology.

**THE OFFICE OF EXPERIMENTAL TECHNOLOGY INCENTIVES PROGRAM** seeks to affect public policy and process to facilitate technological change in the private sector by examining and experimenting with Government policies and practices in order to identify and remove Government-related barriers and to correct inherent market imperfections that impede the innovation process.

**THE OFFICE FOR INFORMATION PROGRAMS** promotes optimum dissemination and accessibility of scientific information generated within NBS; promotes the development of the National Standard Reference Data System and a system of information analysis centers dealing with the broader aspects of the National Measurement System; provides appropriate services to ensure that the NBS staff has optimum accessibility to the scientific information of the world. The Office consists of the following organizational units:

Office of Standard Reference Data — Office of Information Activities — Office of Technical Publications — Library — Office of International Standards — Office of International Relations.

<sup>1</sup> Headquarters and Laboratories at Gaithersburg, Maryland, unless otherwise noted; mailing address Washington, D.C. 20234.

<sup>2</sup> Located at Boulder, Colorado 80302.

NATIONAL BUREAU  
OF STANDARDS  
LIBRARY  
AUG 1 1977  
not Acc.  
QC  
100  
1057  
No. 950  
1977  
C.2

# The NBS Detector Response Transfer and Intercomparison Package: The Instrumentation

± SPECIAL PUBLICATION #950

Michael A. Lind, Edward F. Zalewski,  
and Joel B. Fowler

Institute for Basic Standards  
National Bureau of Standards  
Washington, D.C. 20234



---

U.S. DEPARTMENT OF COMMERCE, Juanita M. Kreps, Secretary

Dr. Sidney Harman, Under Secretary  
Jordan J. Baruch, Assistant Secretary for Science and Technology

U.S. NATIONAL BUREAU OF STANDARDS, Ernest Ambler, Acting Director

Issued July 1977

**National Bureau of Standards Technical Note 950**

Nat. Bur. Stand. (U.S.), Tech. Note 950, 23 pages (July 1977)

CODEN: NBSMA6

U.S. GOVERNMENT PRINTING OFFICE  
WASHINGTON: 1977

---

For sale by the Superintendent of Documents, U.S. Government Printing Office, Washington, D.C. 20402  
Price \$1.10      Stock No. 003-003-01810-4

TABLE OF CONTENTS

	<u>Page</u>
1. INTRODUCTION . . . . .	1
2. CONTENTS OF THE PACKAGE . . . . .	1
3. DESCRIPTION OF THE FILTERS . . . . .	3
4. OPERATION OF THE ELECTRONICS . . . . .	5
5. ELECTRONIC CIRCUIT CALIBRATION PROCEDURE . . . . .	6
6. CIRCUIT DESCRIPTION AND DIAGRAMS . . . . .	7
7. MECHANICAL DESCRIPTION AND DRAWINGS . . . . .	8

LIST OF FIGURES

	<u>Page</u>
1. Photograph of detector head and control unit . . . . .	2
2. Nominal transmission curves for the three absorbing glass filters supplied with the package . . . . .	4
3. Detector head schematic diagram . . . . .	9
4. Detector head layout diagram . . . . .	10
5. Control unit schematic diagram . . . . .	11
6. Control unit layout diagram . . . . .	12
7. Cover cylinder for detector head . . . . .	13
8. Front plate for detector head . . . . .	14
9. Inner shell for detector head . . . . .	15
10. Back plate for detector head . . . . .	16
11. Aperture holder for detector head . . . . .	17
12. Filter glass holder . . . . .	18
13. Interference filter holder . . . . .	19



THE NBS DETECTOR RESPONSE TRANSFER AND INTERCOMPARISON  
PACKAGE: THE INSTRUMENTATION

Michael A. Lind, Edward F. Zalewski and Joel B. Fowler  
Radiometric Physics Section  
Optical Physics Division  
Institute for Basic Standards

A system has been designed to transfer the NBS absolute radiant power base in the 250 to 1150 nm wavelength range. The silicon detector based radiometer and its accompanying test materials can be used to measure the absolute spectral response of detectors and to provide a diagnosis of some common measurement problems. The instrumentation and accompanying components are described in this publication.

Key Words: Absolute radiant power measurements; detector radiometry; detector response transfer instrumentation; radiometers; silicon detectors.

## 1. INTRODUCTION

This publication is a description of the electronic and mechanical aspects of an instrument designed and built by the Electro-Optics Radiometry Group of NBS. Several of these instrument packages were assembled at NBS and will be loaned to those laboratories interested in performing accurate measurements of the absolute spectral response of detectors in the near ultraviolet, visible and near infrared spectral regions. In addition to providing the basis of this measurement capability, the instrument packages include several components intended to diagnose and intercompare each laboratory's capability to accurately transfer absolute response calibrations among various detectors. The general properties of these test components are described here along with their intended use. Specific instructions for the use of these test components along with the measured values of certain key parameters are included with the individual detector response transfer and intercomparison packages.

This publication also includes a complete description of the electronic circuit calibration procedures followed at NBS. Each instrument will be fully characterized both electronically and radiometrically to the limit of the current NBS capability. A complete description of the radiometric characterization procedures will be the topic of a separate publication.

## 2. CONTENTS OF THE PACKAGE

The complete contents of each detector response transfer and intercomparison package are contained in an aluminum case of outside dimensions 18" x 13" x 6" (46 x 33 x 15 cm). Figure 1 shows the two major components



Fig. 1. Photograph of detector head and control unit.



of the package which are a 2.50" diameter x 6.5" long (6.35 x 16.5cm) cylindrical detector head and a 3" x 8" x 11" (7.6 x 20 x 28cm) control unit. A 0.5 cm<sup>2</sup> aperture is mounted in front of the detector, and both the detector and the aperture are protected by a plastic lens cap. In addition, there are three absorbing glass filters and two interference filters each mounted in a special holder that fits onto the front of the detector head. These filters are contained in plastic boxes to protect them in shipping and to prevent surface contamination. Another plastic box contains a wrench and the 2-56 allen cap screws used to mount the filters.

### 3. DESCRIPTION OF THE FILTERS

An accurate absolute spectral response calibration of a detector from NBS will enable other laboratories to determine the absolute spectral response of many other different detectors and radiometers. However, besides the accuracy of the NBS calibration and the various pertinent characteristics of the detector and the electronics, the other key component in the quality of the measurement chain is the accuracy of the user's transfer of this calibration. The detector response transfer package therefore contains several components selected to diagnose and intercompare each laboratory's response transfer capabilities.

Two of the most common sources of error in detector response transfer are inaccuracy in the monochromator wavelength readings and out-of-band (stray) radiation transmitted by the monochromator. To test for the accuracy of the wavelength setting two mounted interference filters are supplied with each instrument. One filter has a transmission peak at approximately 410 nm (serial number's begin with WV) and the other at 940 nm (WR serial numbers). Each laboratory will be requested to use their monochromator and source to measure the central wavelength of each filter when mounted on the detector head.

The other principal source of error, stray radiation, is of two types: radiation from all other wavelengths scattered into the monochromator's transmission band and the second order diffraction present in grating instruments. For instruments employing an incandescent source, the first type of stray radiation is usually a big problem in the blue and uv spectral regions whereas the second is most apparent in the red and ir\*. To test for stray radiation two absorbing glass cut-off filters are supplied. The filter to check for stray radiation at wavelengths shorter than 400 nm (SV serial number) is a 1 mm thick Schott<sup>†</sup> VG-5

---

\*Instruments employing arc sources with intense uv lines are a special case since the second order scatter will occur in the visible.

<sup>†</sup>Certain commercial materials and equipment are identified in order to adequately specify the experimental procedure. In no case does such identification imply recommendation or endorsement by the National Bureau of Standards, nor does it imply that the material or equipment so identified is necessarily the best available for the purpose.

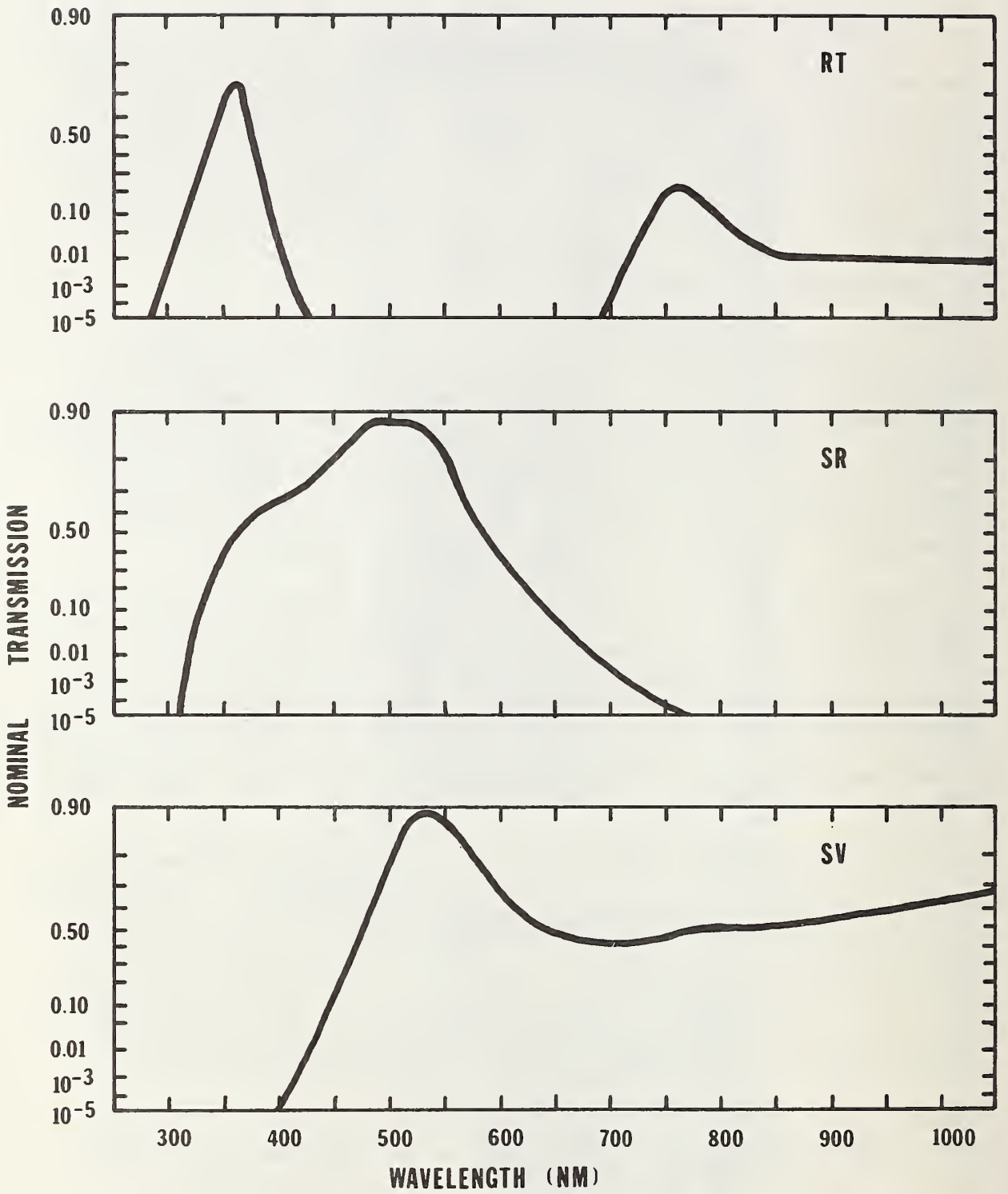

Fig. 2. Nominal transmission curves for the three absorbing glass filters supplied with the package.

glass. For stray radiation at wavelengths longer than 800 nm the filter (SR serial number) is a 1 mm thick Schott BG-18 glass. The nominal transmissions of these filters are displayed in Fig. 2. Each laboratory will be requested to measure the output of their monochromator at specified uv and ir wavelengths using the NBS detector both with and without the cut-off filters.

A good indicator of each laboratory's response transfer capability is how well they can transfer the absolute spectral response from the calibrated silicon detector to another detector having a very different spectral sensitivity. The third absorbing glass filter in the detector response transfer package (RT serial number) is a 2 mm thick filter of Schott UG-1 glass. This is a visible absorbing filter that has transmission peaks in both the uv and ir. (See Fig. 2.) Each laboratory will be requested to measure the spectral response of a test detector (the silicon detector head with the RT filter in place) against that of the silicon detector calibration supplied by NBS. When the SR and SV filters are used in tandem with the silicon detector the response is limited to only visible wavelengths. The laboratories will also be requested to measure at specified wavelengths the response of this combination. From the data on the above two test response functions as supplied by the various laboratories it will be possible to intercompare their spectral response capabilities in three distinct spectral regions: near uv, visible and near ir.

#### 4. OPERATION OF THE ELECTRONICS

This high accuracy transfer standard has been made as rugged as possible to minimize physical damage to the instrument. However, as with any delicate instrument, special care should be taken to protect the instrument from physical abuse. In particular the protective cap that covers the detector should always be replaced when the detector is not in use. In order to insure the highest accuracy it is essential that the detector surface be kept free of contamination and the aperture not sustain any physical damage.

The actual operation of the device has been kept as simple as possible to avoid operator error. Two cables connect the detector head to the control unit. The BNC from the detector head is connected to the ANALOG INPUT on the rear panel of the control unit and, the 15 pin connector from the detector is attached to the appropriate mating connector on the rear of the control unit. The control unit may be plugged into any 110-130 VAC 50-60 Hz outlet.

Switch the AC POWER and the TEMPERATURE CONTROLLER to the ON position. Allow five minutes for the detector temperature to stabilize. The ambient temperature must be below 30 °C for proper operation of the device.

Remove the protective cap from the detector head and adjust the AMPLIFIER GAIN to the maximum setting possible for no OVERLOAD indication. Adjust the TIME CONSTANT to any desired value between .1 and 10 seconds.

The OFF position of the TIME CONSTANT switch is used only to check the offset null of the panel meter. A filtered output is available at the ANALOG OUTPUT on the rear panel of the control unit for use with an external DVM. If an unfiltered output is desired for lock-in-amplifier or other wide bandwidth applications, a BNC "T" may be used at the ANALOG INPUT connector.

## 5. ELECTRONIC CIRCUIT CALIBRATION PROCEDURE

IN ORDER TO INSURE THE MOST ACCURATE TRANSFER MEASUREMENTS, NO ADJUSTMENTS SHOULD BE MADE IN THE FIELD BY THE USER WITHOUT DIRECT CONSULTATION WITH THE ELECTRO-OPTICS GROUP AT THE NATIONAL BUREAU OF STANDARDS.

### Detector Current Amplifier Calibration

Access to the detector head electronics is achieved in the following manner. Remove the aperture plate by removing the three countersunk allen screws. Next remove the three outer countersunk allen screws in the detector plate. Replace the lens cap to protect the detector. Loosen the allen set screw on the side near the back (cable) end of the detector head and slide the outer shell back over the cables.

With the silicon detector covered to insure zero light input, attach the positive side of a stable current generator capable of a 1 mA to 100 nA output to the cathode of the silicon detector SD1, through a 1 K $\Omega$  standard resistor. The anode side of the detector should be connected to the negative side of the generator.

A high accuracy DVM is then used to monitor the current output of the generator by measuring the voltage drop across the standard resistor. Check for possible ground loops by reversing current direction. Locate R2 and R3 using the diagram in Fig. 4. With the current generator set for zero current output, adjust R2 for a minimum voltage at the output of U1. Next adjust R3 for a minimum output of U3.

Adjust the current generator to 1.0000 mA with the gain switch on the front panel of the control unit set to the 10<sup>-4</sup> A/V position. Adjust R14 to read 10.000 V at the output of U3 (the detector head BNC connector). Next adjust the current to 1.0000  $\mu$ A and set the gain switch on the 10<sup>-7</sup> A/V position. The output of U3 should again read 10.000 V. Readjust R14 slightly if necessary. Try the other gain settings to insure the amplifier is scaling properly. Using an iterative procedure it is possible to bring the output of U3 to the correct value within .01% for all gain settings.

There are several adjustments in the control unit electronics that are accessed by removing the two phillips head screws on the rear of the top panel of the box. Set the TIME CONSTANT switch to .1 second. In order to set the zero offset in the filter circuit, it is necessary to

short the ANALOG INPUT BNC. Consult Fig. 6 for the exact location of the test points and component locations. Adjust R23 for a minimum signal at TP2. Then adjust R24 for a minimum signal at the analog output.

The digital panel meter has both zero offset and full scale gain adjustments which are available on the front of the meter. It is necessary to remove the meter to gain access to these controls. First remove the bottom panel of the control unit by removing the two phillips screws on the rear portion of the panel. Next remove the two nylon screws in the center portion of the main printed circuit board. The meter is removed by sliding it back and up over the power supplies. First set the zero offset so the panel meter reads  $0.000 \pm .001$  with the TIME CONSTANT switch in the OFF position. Then inject a dc signal into the ANALOG INPUT input connector. Adjust the input signal to read 10.000 volts at TP2. Adjust the full scale pot on the panel meter to read 10.000 also. The meter offset may be checked at any time by switching the TIME CONSTANT switch to the OFF position.

### Temperature Controller Adjustments

The temperature is set by adjusting R11 in the detector head. In order to insure the best possible transfer measurements all characterizations of the detectors have been performed with the temperature of the substrate controlled at 30.0 °C to better than  $\pm 0.1$  °C. It should be noted that substantial changes in the characteristics of the silicon detectors will occur especially in the UV and IR if this temperature is altered.

## 6. CIRCUIT DESCRIPTION AND DIAGRAMS

### Detector Head

The detector head is shown schematically in Fig. 3 and a layout drawing is given in Fig. 4. The head is connected to the control unit by two cables. It contains all the sensitive electronics in the package and should be handled with extreme care.

The head electronics operate in the following manner. The current generated by the silicon detector SD1 (operated in a photovoltaic or short circuit mode) is converted to a voltage using a low noise, low drift amplifier (U1) with the laser trimmed resistance network R1 as the feedback element. The resistance ratios in the metal film network are accurate to .01%. The feedback resistance of the amplifier can be varied from 10 M $\Omega$  to 10 K $\Omega$  in decade steps by activating the low thermal reed relays K1 to K4.

The output of U1 is fed into a scaling amplifier U3 in order to compensate for the nominal absolute resistance of R1. The gain of U3 is varied by adjusting R14. The absolute uncertainty in the detector current output can be trimmed to approximately .01%. The output of U3 is fed directly into a coax cable which is normally connected to the input of the control unit.

Also included in the head is a temperature control unit. Amplifier U2 senses the voltage difference between a set point determined by R11 in one leg of a bridge and the thermistor TH1 in the other leg. The thermistor is in thermal contact with the back of the detector. U2 drives a follower Q21 located in the control unit which in turn supplies current to the heater HR1 attached to the back of the silicon detector. The temperature can be stabilized to better than 0.1 °C at temperatures slightly above ambient.

### Control Unit

The control unit houses the power supplies, signal filter, overload indicator, and digital readout. The unit is shown schematically in Fig. 5 and a parts layout is shown in Fig. 6.

The signal from the analog input is fed into a unity gain two pole filter U21 with time constants of 0.1, 0.3, 1.0, 3.0, and 10 seconds adjustable via a front panel rotary switch. This signal is fed into the digital panel meter and output buffer.

The input is also buffered by U23 and examined by a bi-polar over-voltage indicator comprised of U24 and U25. A voltage greater than ±12 volts discharges the capacitor C31 which in turn activates the LED overload indicator D26 via the amplifier U26. The resistance of R30 controls the recharge rate of C31, thus insuring that the LED stays lit long enough to be visible even for transient pulses at the analog input.

Another front panel rotary switch controls the gain relays in the detector head.

## 7. MECHANICAL DESCRIPTION AND DRAWINGS

### Detector Head

The mechanical parts of the detector head are constructed from ten basic pieces. An outer cylinder illustrated in Fig. 7 protects all the sensitive electronics. The front plate in Fig. 8 holds a Delrin insert which in turn holds the silicon detector in place. This plate is fastened to the inner half cylinder in Fig. 9 with two allen head screws. The detector head printed circuit board mounts onto this half cylinder. The back plate which is shown in Fig. 10 has two feed-throughs for the detector head control umbilical and output cables. This plate is also mounted to the inner half cylinder with two allen head screws.

A self-centering aperture holder shown in Fig. 11 holds a precision 0.5 cm<sup>2</sup> aperture. The back of the aperture is coated with 3M Black Velvet paint to minimize interreflections between the aperture and the detector surface. The instrument should normally be used only with this aperture in place.

The two types of self-centering filter holders are shown in Fig. 12 and Fig. 13. These holders are used to mount the filter glasses and interference filters supplied with the package.

# DETECTOR HEAD SCHEMATIC

## DETECTOR RESPONSE INTERCOMPARISON PACKAGE

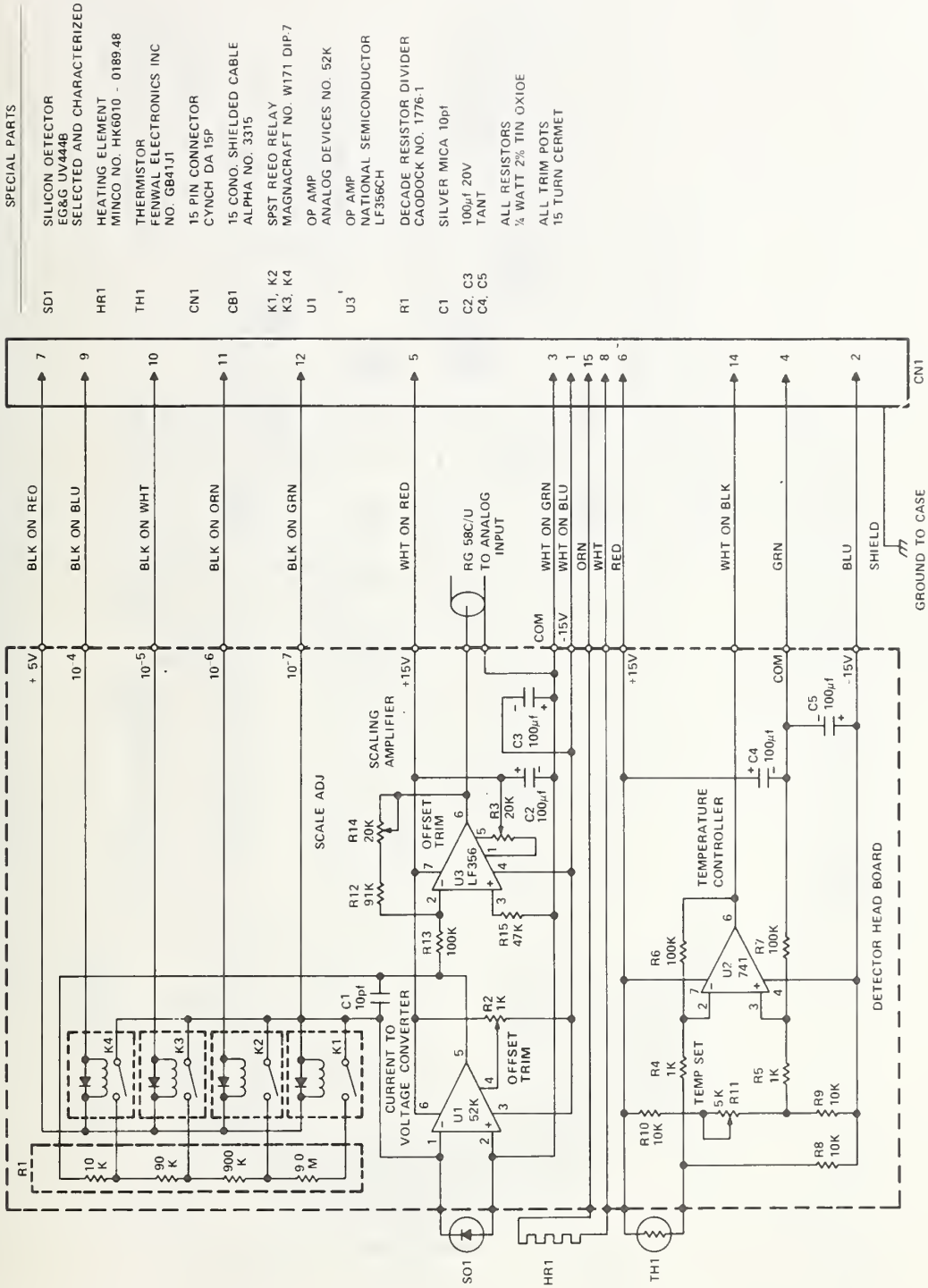

Fig. 3. Detector head schematic diagram.

# DETECTOR HEAD LAYOUT

DETECTOR RESPONSE INTERCOMPARISON PACKAGE

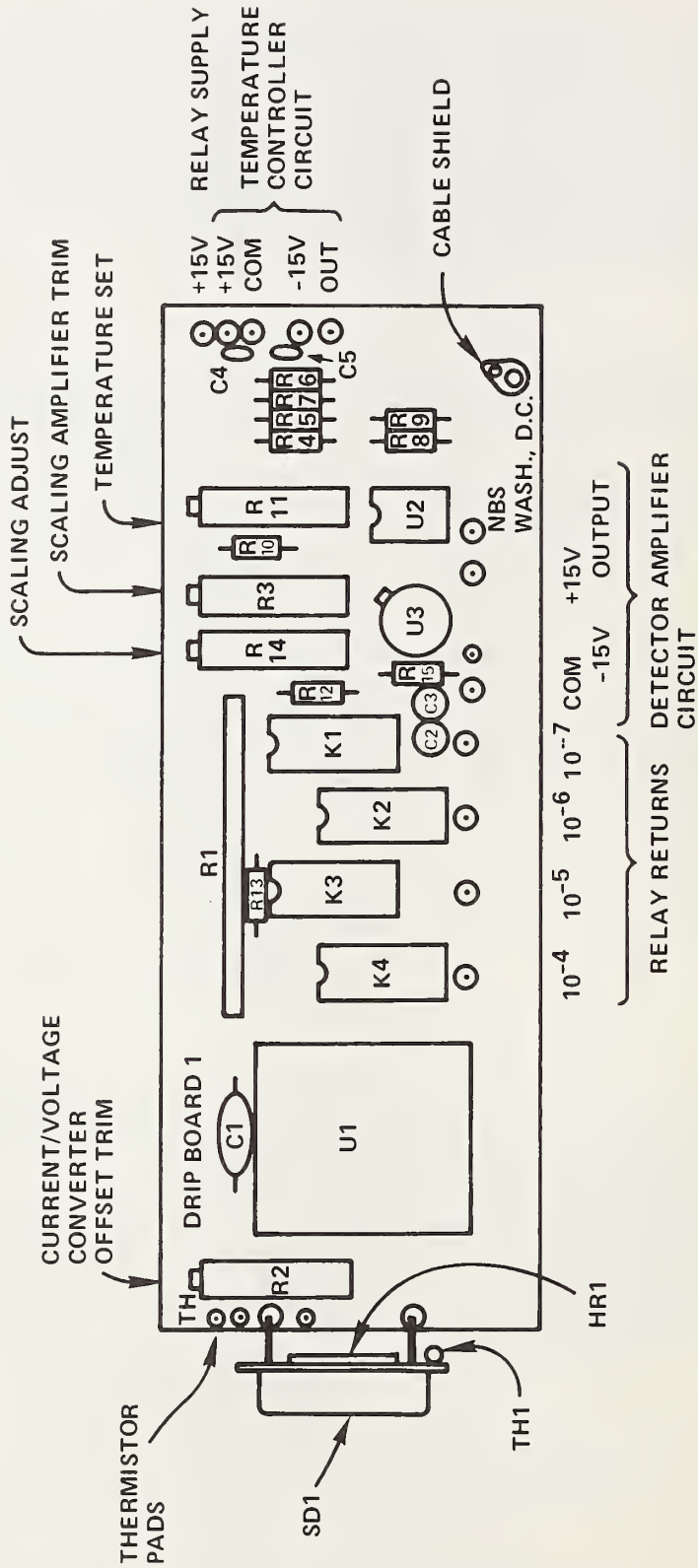

Fig. 4. Detector head layout diagram.



# CONTROL UNIT SCHEMATIC

## DETECTOR RESPONSE INTERCOMPARISON PACKAGE

### OVERLOAD INDICATOR

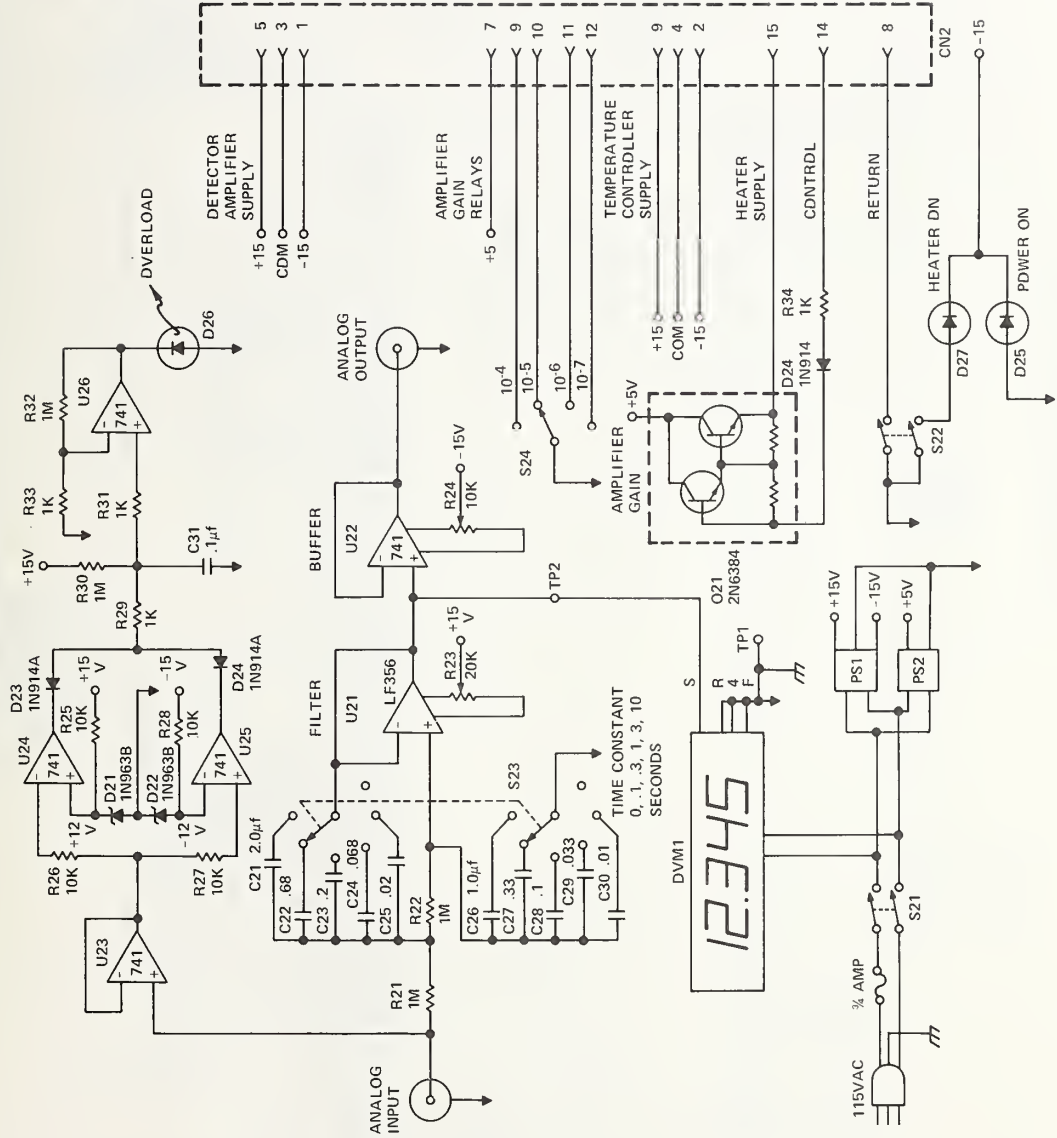

### SPECIAL PARTS

- |          |                           |
|----------|---------------------------|
| U21      | DP AMP                    |
|          | NATIONAL SEMICONDUCTOR    |
|          | LF 356H                   |
| D25, D26 | L.E.D.'S CURRENT LIMITING |
| D27      | 20VDC                     |
| C21-C30  | CAPACITORS                |
|          | CDE MFP SERIES 50V        |
| DVM1     | 4 1/2 DIGIT DPM           |
|          | FAIRCHILD MODEL 54        |
| Q21      | POWER DARLINGTON          |
|          | RCA 2N6384                |
| PS1      | POWER SUPPLY              |
|          | BOSTON TECH               |
|          | MODEL 2.15.100            |
| PS2      | POWER SUPPLY              |
|          | BOSTON TECH               |
|          | MODEL 1.5.1000            |
|          | AU RESISTORS              |
|          | 1/4 WATT 2% TIN OXIDE     |
|          | ALL TRIM PDTS             |
|          | 15 TURN CERMET            |
| CN2      | 15 PIN CONNECTOR          |
|          | CYNCH DA-155              |

Fig. 5. Control unit schematic diagram.

# CONTROL UNIT LAYOUT

DETECTOR RESPONSE INTERCOMPARISON PACKAGE

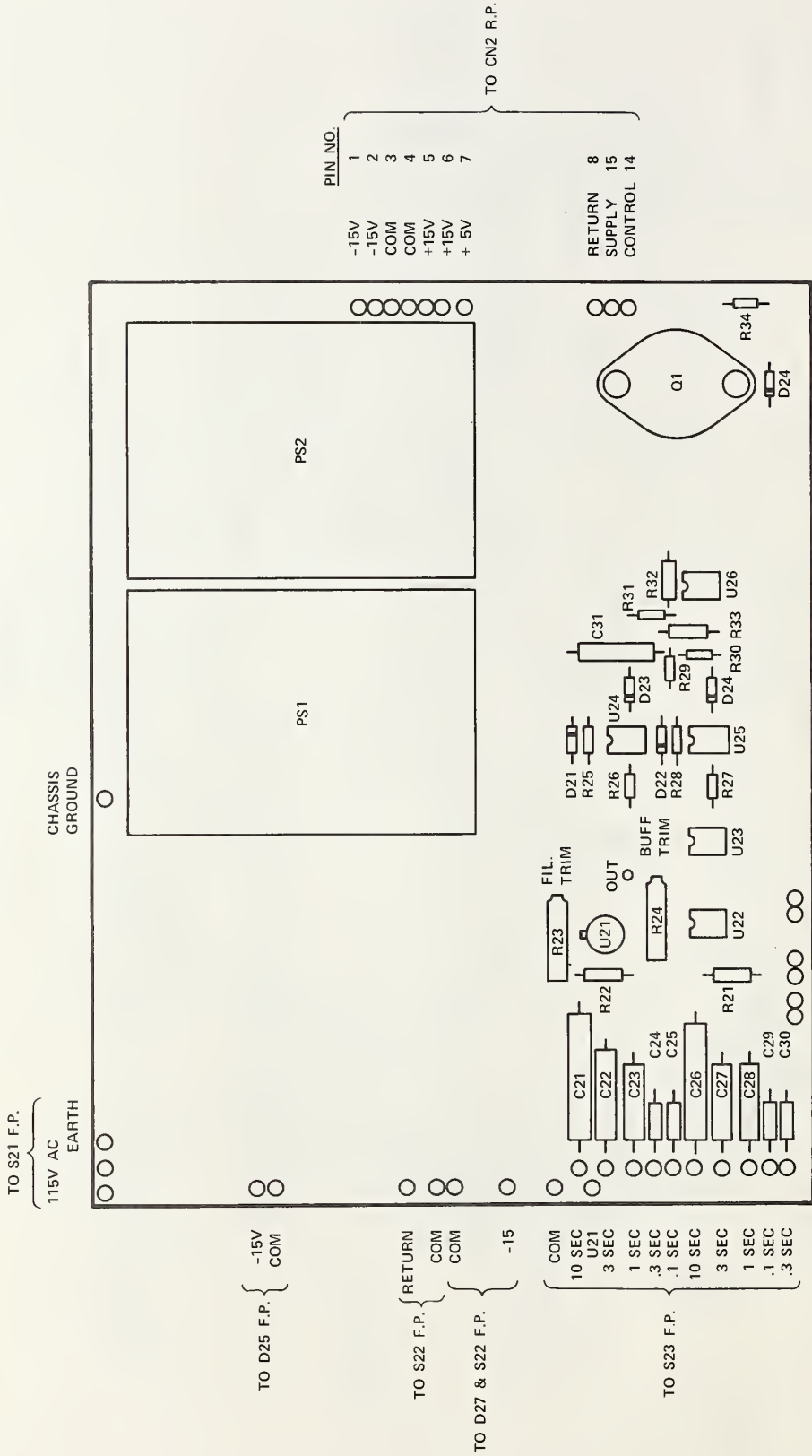

Fig. 6: Control unit layout diagram.

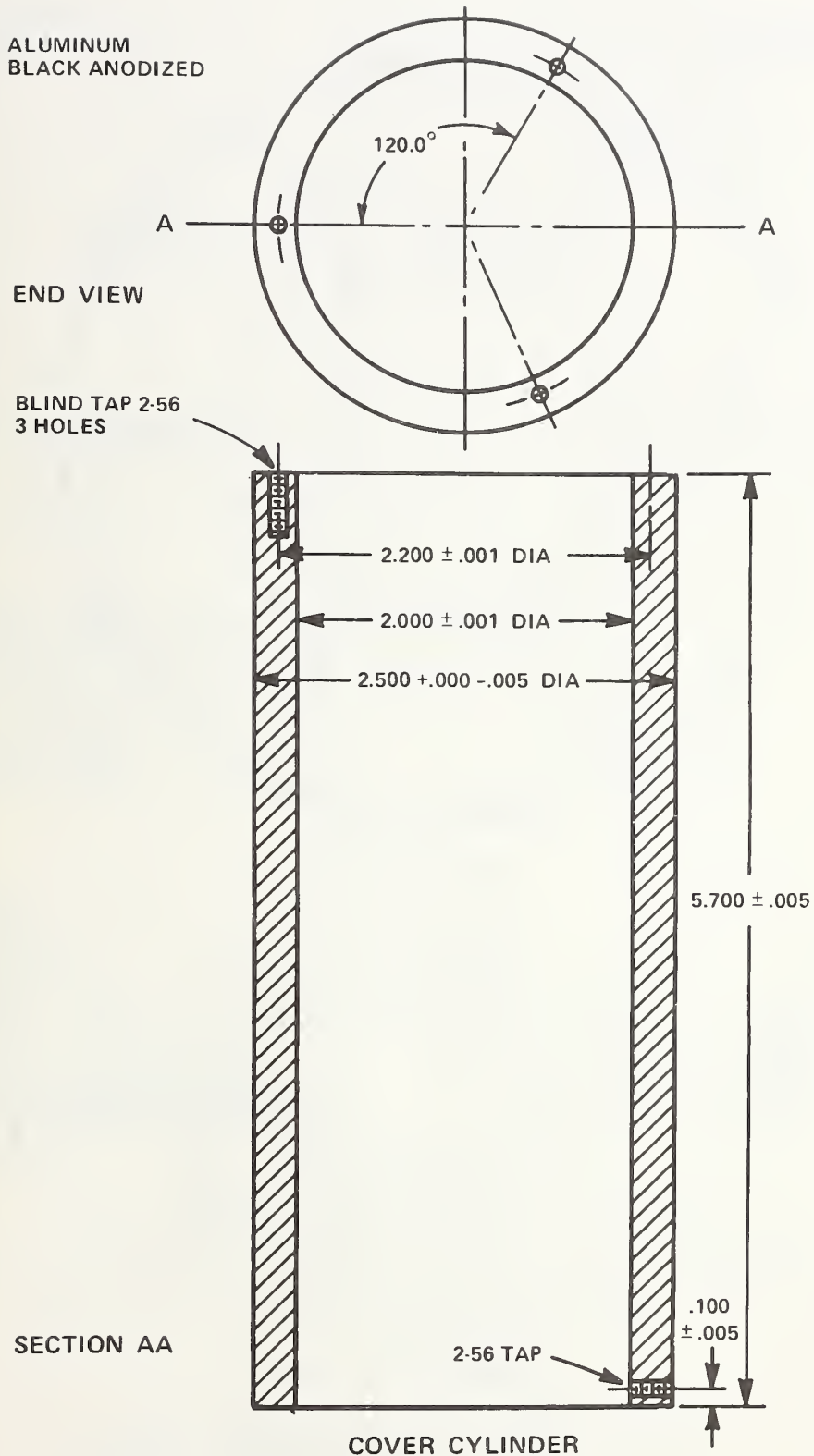
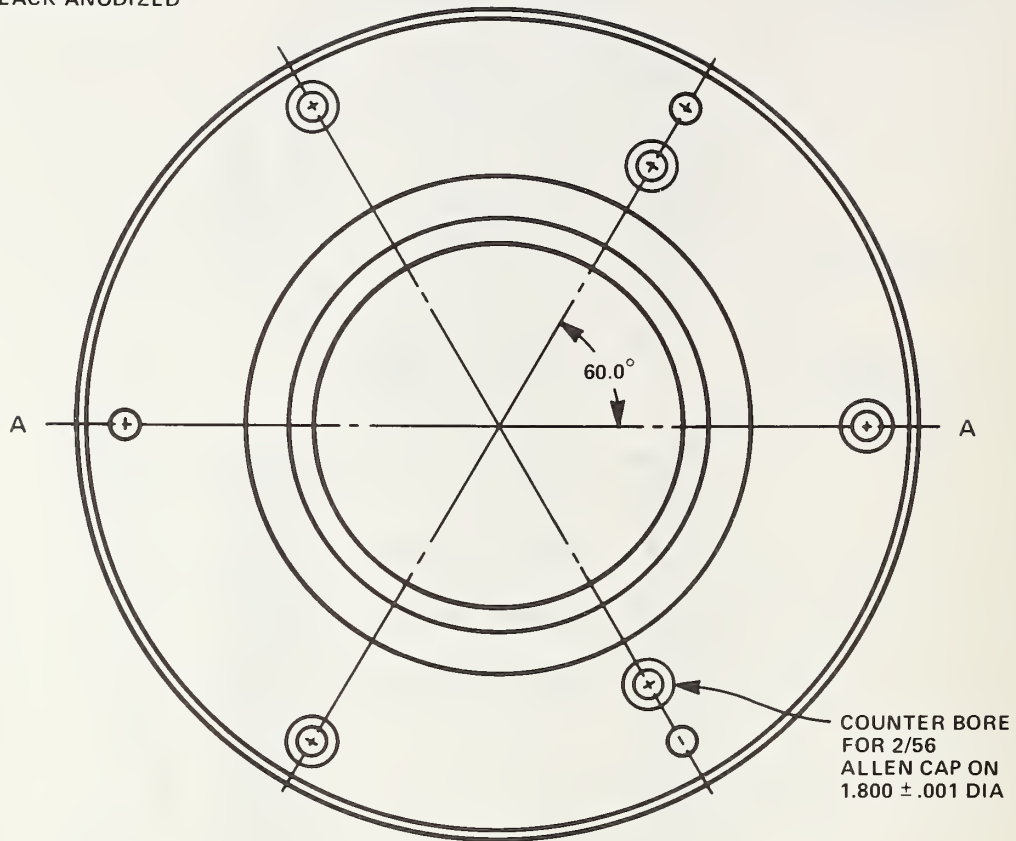
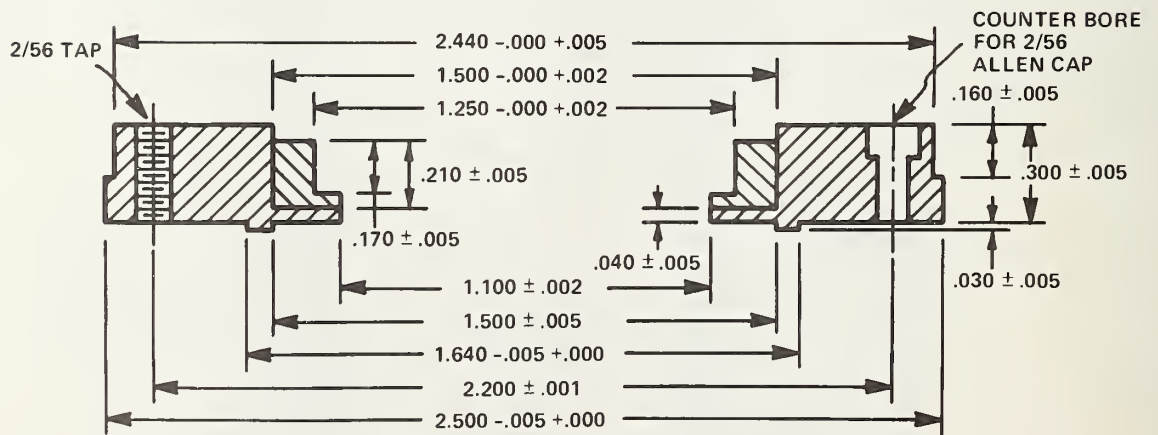

Fig. 7. Cover cylinder for detector head.

ALUMINUM  
BLACK ANODIZED



TOP VIEW



SECTION AA  
FRONT PLATE

Fig. 8. Front plate for detector head.

ALUMINUM  
BLACK ANODIZED

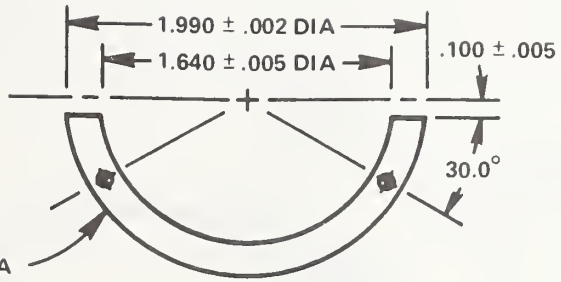

2-56 BLIND TAP  
ON 1.800 ± .001 DIA  
BOTH ENDS

END VIEW

2.00" O.D. .180" WALL  
ALUMINUM EXTRUDED STOCK  
NO INTERIOR MACHINING  
NECESSARY

2-56 BLIND TAP  
4 HOLES

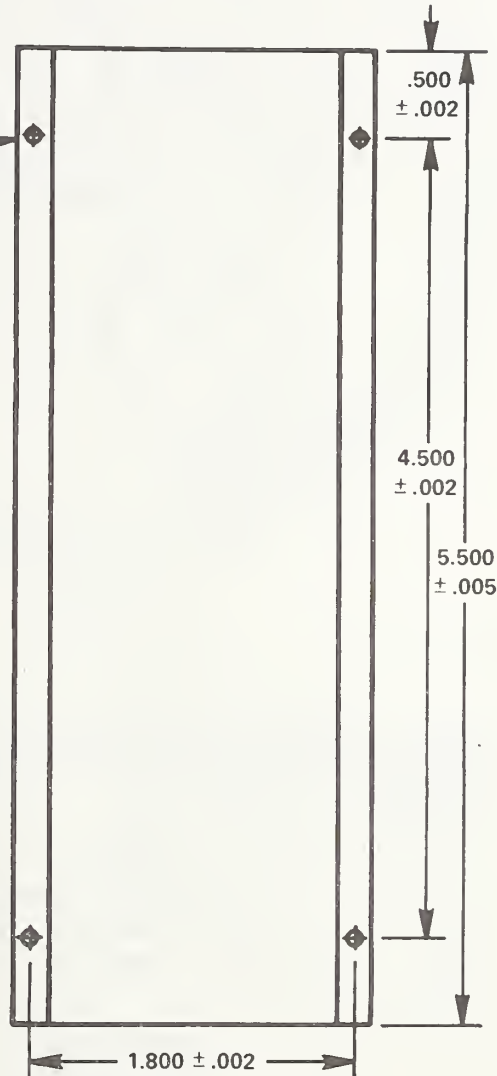

TOP VIEW  
INNER SHELL

Fig. 9. Inner shell for detector head.

ALUMINUM  
BLACK ANODIZED

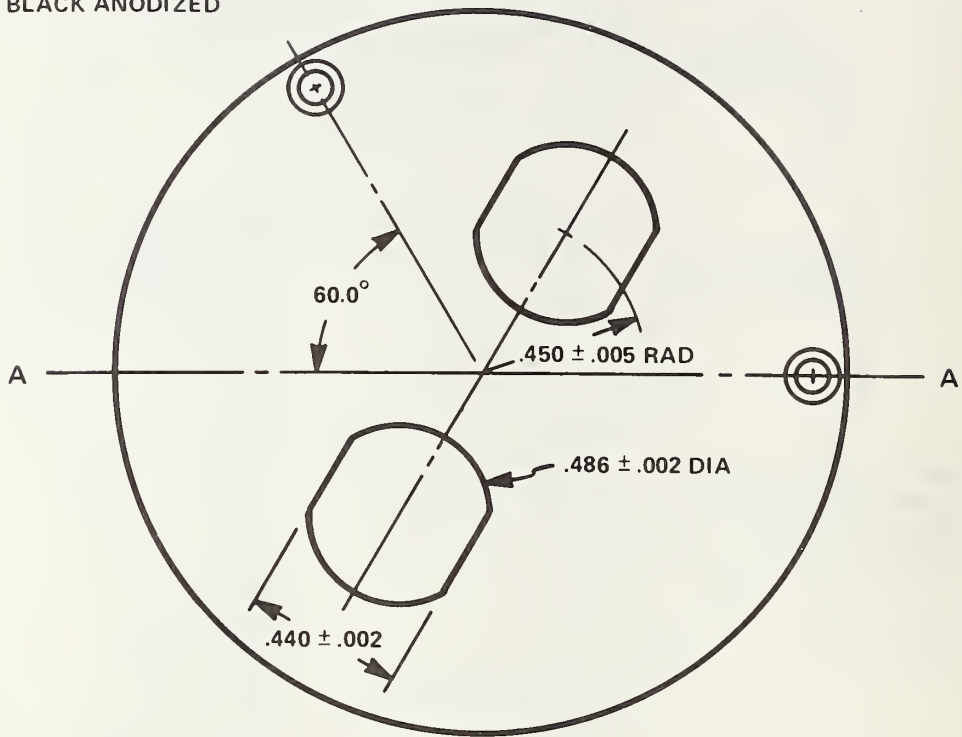

TOP VIEW

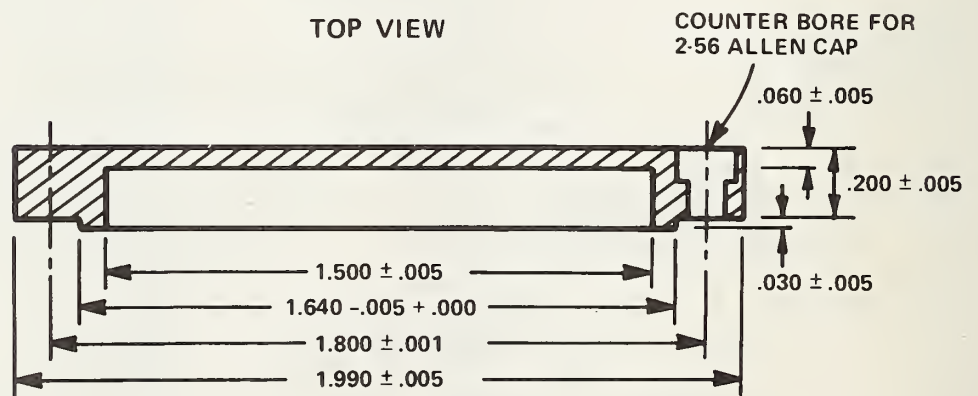

SECTION AA  
BACK PLATE

Fig. 10. Back plate for detector head.

ALUMINUM  
BLACK ANODIZED

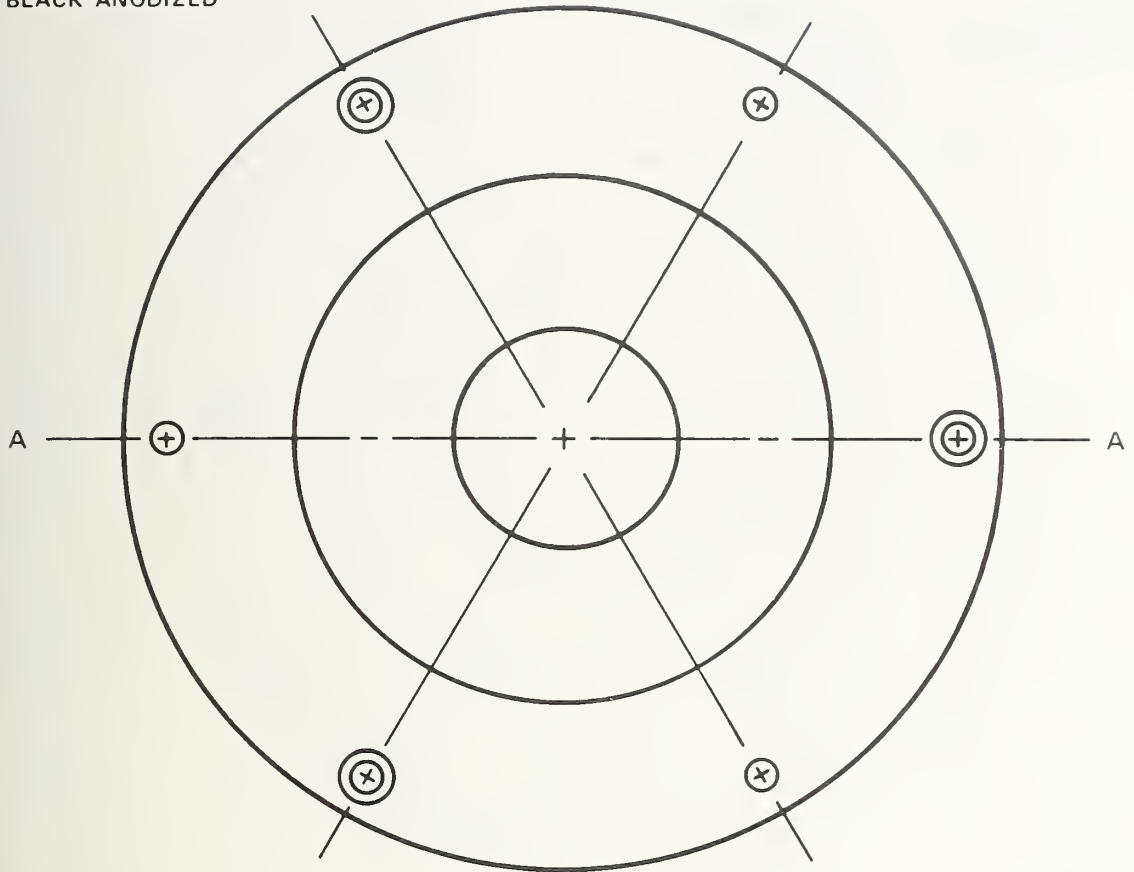

TOP VIEW

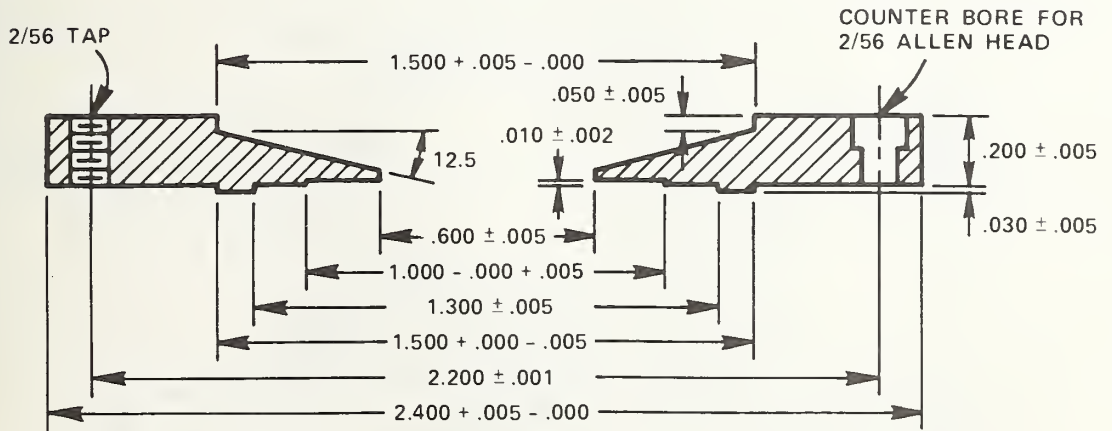

SECTION AA  
APERTURE HOLDER

Fig. 11. Aperture holder for detector head.

ALUMINUM  
BLACK ANODIZED

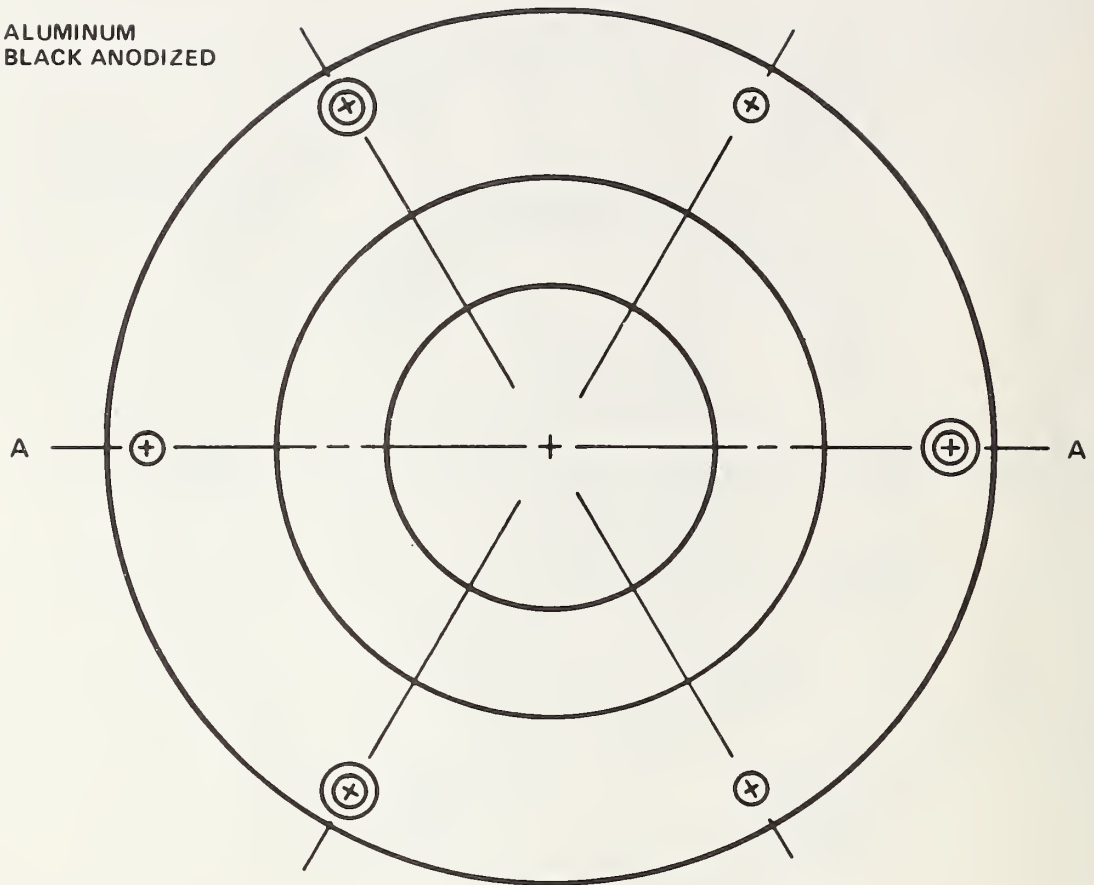

TOP VIEW

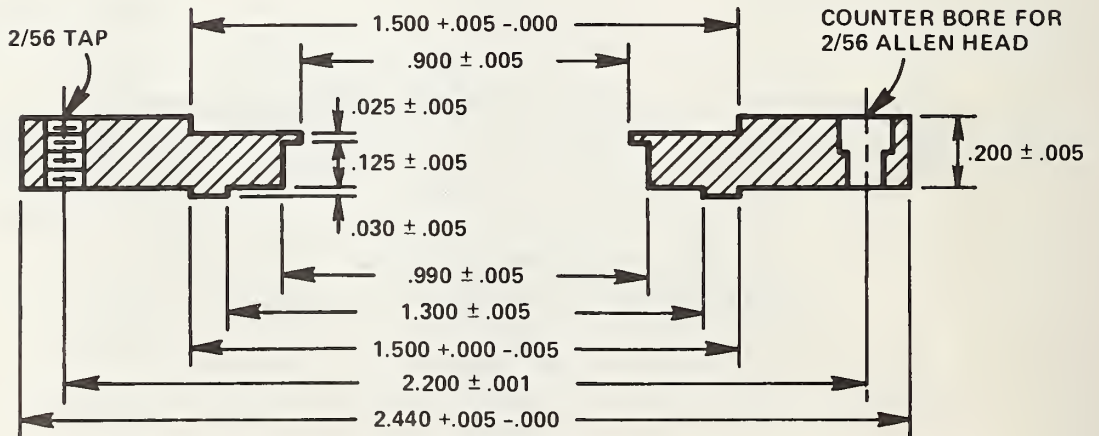

SECTION AA  
FILTER GLASS HOLDER

Fig. 12. Filter glass holder.



ALUMINUM  
BLACK ANODIZED

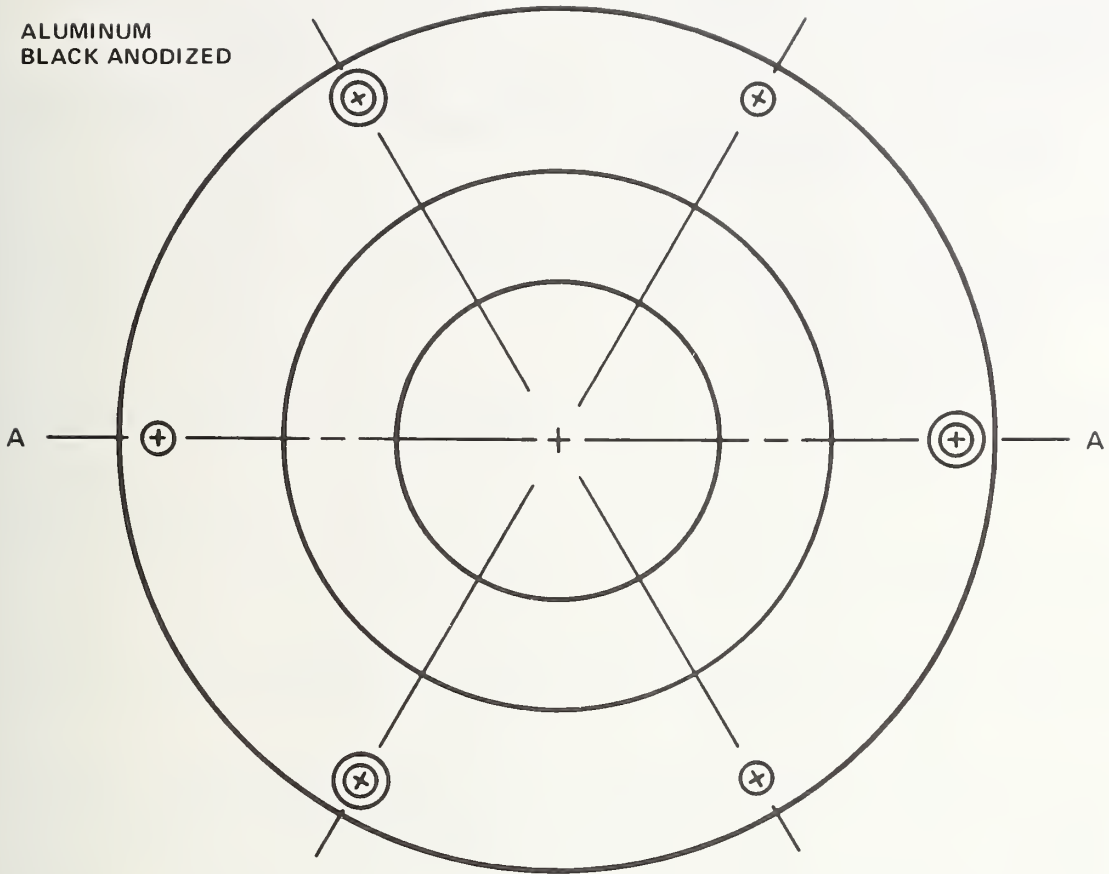

TOP VIEW

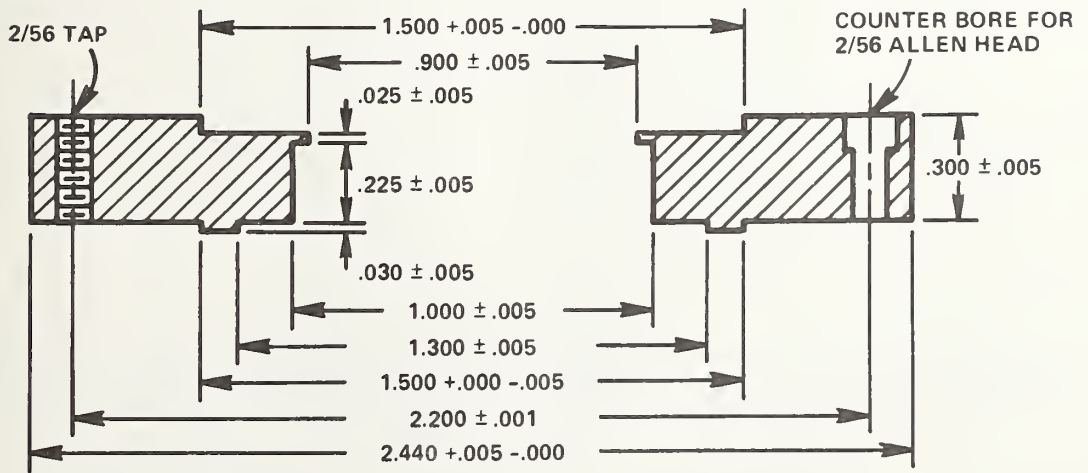

SECTION AA  
INTERFERENCE FILTER HOLDER

Fig. 13. Interference filter holder.

U.S. DEPT. OF COMM. <b>BIBLIOGRAPHIC DATA SHEET</b>	1. PUBLICATION OR REPORT NO. NBS TN 950	2. Gov't Accession No.	3. Recipient's Accession No.
4. TITLE AND SUBTITLE  THE NBS DETECTOR RESPONSE TRANSFER AND INTERCOMPARISON PACKAGE: THE INSTRUMENTATION		5. Publication Date July 1977	6. Performing Organization Code
7. AUTHOR(S) Michael A. Lind, Edward F. Zalewski and Joel B. Fowler		8. Performing Organ. Report No.	
9. PERFORMING ORGANIZATION NAME AND ADDRESS  NATIONAL BUREAU OF STANDARDS DEPARTMENT OF COMMERCE WASHINGTON, D.C. 20234		10. Project/Task/Work Unit No.	11. Contract/Grant No.
12. Sponsoring Organization Name and Complete Address (Street, City, State, ZIP)		13. Type of Report & Period Covered Final	14. Sponsoring Agency Code
15. SUPPLEMENTARY NOTES			
16. ABSTRACT (A 200-word or less factual summary of most significant information. If document includes a significant bibliography or literature survey, mention it here.)  A system has been designed to transfer the NBS absolute radiant power base in the 250 to 1150 nm wavelength range. The silicon detector based radiometer and its accompanying test materials can be used to measure the absolute spectral response of detectors and to provide a diagnosis of some common measurement problems. The instrumentation and accompanying components are described in this publication.			
17. KEY WORDS (six to twelve entries; alphabetical order; capitalize only the first letter of the first key word unless a proper name; separated by semicolons) Absolute radiant power measurements; detector radiometry; detector response transfer instrumentation; radiometers; silicon detectors.			
18. AVAILABILITY  <input type="checkbox"/> For Official Distribution. Do Not Release to NTIS  <input checked="" type="checkbox"/> Order From Sup. of Doc., U.S. Government Printing Office Washington, D.C. 20402, SD Cat. No. C13 46:950  <input type="checkbox"/> Order From National Technical Information Service (NTIS) Springfield, Virginia 22151	19. SECURITY CLASS (THIS REPORT)  UNCLASSIFIED	21. NO. OF PAGES  23	
		20. SECURITY CLASS (THIS PAGE)  UNCLASSIFIED	22. Price  \$1.10

# NBS TECHNICAL PUBLICATIONS

## PERIODICALS

**JOURNAL OF RESEARCH** reports National Bureau of Standards research and development in physics, mathematics, and chemistry. It is published in two sections, available separately:

• **Physics and Chemistry (Section A)**

Papers of interest primarily to scientists working in these fields. This section covers a broad range of physical and chemical research, with an emphasis on standards of physical measurement, fundamental constants, and properties of matter. Issued six times a year. Annual subscription: Domestic, \$17.00; Foreign, \$21.25.

• **Mathematical Sciences (Section B)**

Studies and communications designed mainly for the mathematician and theoretical physicist. Topics in mathematical statistics, theory of experiment design, numerical analysis, theoretical physics and chemistry, logical design, programming of computers and computer systems, and short numerical tables. Issued quarterly. Annual subscription: Domestic, \$9.00; Foreign, \$11.25.

**DIMENSIONS/NBS (formerly Technical News Bulletin)**—This monthly magazine is published to inform scientists, engineers, businessmen, industry, teachers, students, and consumers of the latest advances in science and technology, with primary emphasis on the work at NBS. The magazine highlights and reviews such issues as energy research, fire protection, building technology, metric conversion, pollution abatement, health and safety, and consumer product performance. In addition, it reports the results of Bureau programs in measurement standards and techniques, properties of matter and materials, engineering standards and services, instrumentation, and automatic data processing.

Annual subscription: Domestic, \$12.50; Foreign, \$15.65.

## NONPERIODICALS

**Monographs**—Major contributions to the technical literature on various subjects related to the Bureau's scientific and technical activities.

**Handbooks**—Recommended codes of engineering and industrial practice (including safety codes) developed in cooperation with interested industries, professional organizations, and regulatory bodies.

**Special Publications**—Include proceedings of conferences sponsored by NBS, NBS annual reports, and other special publications appropriate to this grouping such as wall charts, pocket cards, and bibliographies.

**Applied Mathematics Series**—Mathematical tables, manuals, and studies of special interest to physicists, engineers, chemists, biologists, mathematicians, computer programmers, and others engaged in scientific and technical work.

**National Standard Reference Data Series**—Provides quantitative data on the physical and chemical properties of materials, compiled from the world's literature and critically evaluated. Developed under a world-wide program coordinated by NBS. Program under authority of National Standard Data Act (Public Law 90-396).

## BIBLIOGRAPHIC SUBSCRIPTION SERVICES

The following current-awareness and literature-survey bibliographies are issued periodically by the Bureau:

**Cryogenic Data Center Current Awareness Service.** A literature survey issued biweekly. Annual subscription: Domestic, \$25.00; Foreign, \$30.00.

**Liquified Natural Gas.** A literature survey issued quarterly. Annual subscription: \$20.00.

**NOTE:** At present the principal publication outlet for these data is the Journal of Physical and Chemical Reference Data (JPCRD) published quarterly for NBS by the American Chemical Society (ACS) and the American Institute of Physics (AIP). Subscriptions, reprints, and supplements available from ACS, 1155 Sixteenth St. N.W., Wash. D. C. 20056.

**Building Science Series**—Disseminates technical information developed at the Bureau on building materials, components, systems, and whole structures. The series presents research results, test methods, and performance criteria related to the structural and environmental functions and the durability and safety characteristics of building elements and systems.

**Technical Notes**—Studies or reports which are complete in themselves but restrictive in their treatment of a subject. Analogous to monographs but not so comprehensive in scope or definitive in treatment of the subject area. Often serve as a vehicle for final reports of work performed at NBS under the sponsorship of other government agencies.

**Voluntary Product Standards**—Developed under procedures published by the Department of Commerce in Part 10, Title 15, of the Code of Federal Regulations. The purpose of the standards is to establish nationally recognized requirements for products, and to provide all concerned interests with a basis for common understanding of the characteristics of the products. NBS administers this program as a supplement to the activities of the private sector standardizing organizations.

**Consumer Information Series**—Practical information, based on NBS research and experience, covering areas of interest to the consumer. Easily understandable language and illustrations provide useful background knowledge for shopping in today's technological marketplace.

*Order above NBS publications from: Superintendent of Documents, Government Printing Office, Washington, D.C. 20402.*

*Order following NBS publications—NBSIR's and FIPS from the National Technical Information Services, Springfield, Va. 22161.*

**Federal Information Processing Standards Publications (FIPS PUBS)**—Publications in this series collectively constitute the Federal Information Processing Standards Register. Register serves as the official source of information in the Federal Government regarding standards issued by NBS pursuant to the Federal Property and Administrative Services Act of 1949 as amended, Public Law 89-306 (79 Stat. 1127), and as implemented by Executive Order 11717 (38 FR 12315, dated May 11, 1973) and Part 6 of Title 15 CFR (Code of Federal Regulations).

**NBS Interagency Reports (NBSIR)**—A special series of interim or final reports on work performed by NBS for outside sponsors (both government and non-government). In general, initial distribution is handled by the sponsor; public distribution is by the National Technical Information Services (Springfield, Va. 22161) in paper copy or microfiche form.

**Superconducting Devices and Materials.** A literature survey issued quarterly. Annual subscription: \$30.00. Send subscription orders and remittances for the preceding bibliographic services to National Bureau of Standards, Cryogenic Data Center (275.02) Boulder, Colorado 80302.

**U.S. DEPARTMENT OF COMMERCE**  
**National Bureau of Standards**  
Washington, D.C. 20234

OFFICIAL BUSINESS

Penalty for Private Use, \$300

POSTAGE AND FEES PAID  
U.S. DEPARTMENT OF COMMERCE  
COM-215



SPECIAL FOURTH-CLASS RATE  
BOOK