

NBS TECHNICAL NOTE 644

A UNITED STATES
DEPARTMENT OF
COMMERCE
PUBLICATION



APPLICATION OF A NON-IDEAL SLIDING SHORT TO TWO-PORT LOSS MEASUREMENT

QC
100
U5753
no. 644
1973
c.2

U.S.
DEPARTMENT
OF
COMMERCE

National
Bureau
of
Standards

NATIONAL BUREAU OF STANDARDS

The National Bureau of Standards¹ was established by an act of Congress March 3, 1901. The Bureau's overall goal is to strengthen and advance the Nation's science and technology and facilitate their effective application for public benefit. To this end, the Bureau conducts research and provides: (1) a basis for the Nation's physical measurement system, (2) scientific and technological services for industry and government, (3) a technical basis for equity in trade, and (4) technical services to promote public safety. The Bureau consists of the Institute for Basic Standards, the Institute for Materials Research, the Institute for Applied Technology, the Institute for Computer Sciences and Technology, and the Office for Information Programs.

THE INSTITUTE FOR BASIC STANDARDS provides the central basis within the United States of a complete and consistent system of physical measurement; coordinates that system with measurement systems of other nations; and furnishes essential services leading to accurate and uniform physical measurements throughout the Nation's scientific community, industry, and commerce. The Institute consists of a Center for Radiation Research, an Office of Measurement Services and the following divisions:

Applied Mathematics — Electricity — Mechanics — Heat — Optical Physics — Nuclear Sciences² — Applied Radiation² — Quantum Electronics³ — Electromagnetics³ — Time and Frequency³ — Laboratory Astrophysics³ — Cryogenics³.

THE INSTITUTE FOR MATERIALS RESEARCH conducts materials research leading to improved methods of measurement, standards, and data on the properties of well-characterized materials needed by industry, commerce, educational institutions, and Government; provides advisory and research services to other Government agencies; and develops, produces, and distributes standard reference materials. The Institute consists of the Office of Standard Reference Materials and the following divisions:

Analytical Chemistry — Polymers — Metallurgy — Inorganic Materials — Reactor Radiation — Physical Chemistry.

THE INSTITUTE FOR APPLIED TECHNOLOGY provides technical services to promote the use of available technology and to facilitate technological innovation in industry and Government; cooperates with public and private organizations leading to the development of technological standards (including mandatory safety standards), codes and methods of test; and provides technical advice and services to Government agencies upon request. The Institute consists of a Center for Building Technology and the following divisions and offices:

Engineering and Product Standards — Weights and Measures — Invention and Innovation — Product Evaluation Technology — Electronic Technology — Technical Analysis — Measurement Engineering — Structures, Materials, and Life Safety⁴ — Building Environment⁴ — Technical Evaluation and Application⁴ — Fire Technology.

THE INSTITUTE FOR COMPUTER SCIENCES AND TECHNOLOGY conducts research and provides technical services designed to aid Government agencies in improving cost effectiveness in the conduct of their programs through the selection, acquisition, and effective utilization of automatic data processing equipment; and serves as the principal focus within the executive branch for the development of Federal standards for automatic data processing equipment, techniques, and computer languages. The Center consists of the following offices and divisions:

Information Processing Standards — Computer Information — Computer Services — Systems Development — Information Processing Technology.

THE OFFICE FOR INFORMATION PROGRAMS promotes optimum dissemination and accessibility of scientific information generated within NBS and other agencies of the Federal Government; promotes the development of the National Standard Reference Data System and a system of information analysis centers dealing with the broader aspects of the National Measurement System; provides appropriate services to ensure that the NBS staff has optimum accessibility to the scientific information of the world. The Office consists of the following organizational units:

Office of Standard Reference Data — Office of Technical Information and Publications — Library — Office of International Relations.

¹ Headquarters and Laboratories at Gaithersburg, Maryland, unless otherwise noted; mailing address Washington, D.C. 20234.

² Part of the Center for Radiation Research.

³ Located at Boulder, Colorado 80302.

⁴ Part of the Center for Building Technology.

APPLICATION OF A NON-IDEAL SLIDING SHORT TO TWO-PORT LOSS MEASUREMENT

M. P. Weidman
G. F. Engen

Electromagnetics Division
Institute for Basic Standards
National Bureau of Standards
Boulder, Colorado 80302



U.S. DEPARTMENT OF COMMERCE, Frederick B. Dent, Secretary

NATIONAL BUREAU OF STANDARDS, Richard W. Roberts, Director

Issued October 1973

National Bureau of Standards Technical Note 644

Nat. Bur. Stand. (U.S.) , Tech. Note 644, 40 pages (October 1973)

CODEN: NBTNAE

CONTENTS

| | <u>Page</u> |
|--------------------------------------|-------------|
| 1. INTRODUCTION----- | 1 |
| 2. BASIC THEORY----- | 2 |
| 3. INSTRUMENTATION AND HARDWARE----- | 11 |
| 4. SUMMARY----- | 22 |
| 5. ACKNOWLEDGMENT----- | 22 |
| 6. REFERENCES----- | 23 |

LIST OF FIGURES

| | |
|---|----|
| Fig. 1. An ideal reflectometer which measures complex reflection coefficient----- | 24 |
| Fig. 2. Locus of w for a non-ideal reflectometer----- | 25 |
| Fig. 3. A practical measurement system using non-ideal components----- | 26 |
| Fig. 4. Response of system using an ideal sliding short----- | 27 |
| Fig. 5. Actual response of system showing effect of short losses----- | 28 |
| Fig. 6. Alternative form of measurement system----- | 29 |
| Fig. 7. A third example of a tunable 4-arm reflectometer for measuring 2-port efficiency--- | 30 |
| Fig. 8. Measurement system for evaluating 2-port efficiency----- | 31 |
| Fig. 9. Examples of two non-contacting sliding shorts- | 32 |
| Fig. 10. Plot of P_3 vs. sliding short position for T_Y tuning----- | 33 |
| Fig. 11. Calibrated XY-plot for calculating 2-port efficiency----- | 34 |

APPLICATION OF A NON-IDEAL SLIDING SHORT
TO TWO-PORT LOSS MEASUREMENT

M.P. Weidman and G.F. Engen

A detailed, applications oriented, description of a method for measuring two-port losses is given. The technique involved uses a non-ideal sliding short circuit and a tuned four-arm reflectometer. Most, if not all, of the components used in this technique can be put together using commercially available items. It is the intent of this discussion to provide enough detail and explanation so that a technician with some working knowledge of microwave measurements can set up and make loss measurements.

The reference made to two-ports implies a broad range of devices from a simple flange or connector to waveguide coaxial adaptors and even more elaborate configurations with a definable input and output connection.

Key words: Efficiency; loss; reflectometer; sliding short; two-port.

1. INTRODUCTION

It is very often necessary to know the losses in various components and connectors of a measurement system. A convenient technique for measuring these losses involves the use of a sliding short circuit. Although such methods have been known for a number of years [1], the error due to losses in the sliding short (which may be larger than those in the component under investigation) have only recently been evaluated [2,3] and largely eliminated by suitable procedures.

The measurement technique yields the efficiency of a two-port circuit. Typical examples of two-ports which can be evaluated in this way are a coaxial or waveguide connector, a coaxial to waveguide adapter, or a waveguide adapter with two different sizes or types of input and output leads.

The efficiency of a two-port is defined as the ratio of the net power output of the device to the net power input, and depends upon the impedance terminating the output of the two-port, but not on the generator impedance feeding the input port.

The technique described here is useful for devices with small losses (loss < 3 dB). It is especially useful where losses are only a few hundredth's or thousandth's of a dB where the resolution of more conventional attenuation measuring systems is inadequate. (The dB loss is 10 times the logarithm to the base 10 of the efficiency of the two-port.)

2. BASIC THEORY

As noted in the introduction, the techniques which will be described in the paragraphs to follow are based on earlier papers [2,3]. This section will briefly summarize the pertinent theory.

It will prove convenient to begin with an ideal 4-arm junction (reflectometer), as shown in figure 1.¹ It is also convenient to assume that the sidearms are connected to a detector which yields the phase difference between the reflected and incident waves in addition to the more conventional ratio between their amplitudes. The assumed complex ratio detector actually determines the ratio b_3/b_4 where b_3 and b_4 are respectively the wave amplitudes in the sidearms 3 and 4 respectively. However, for an ideal reflectometer, this ratio is equal to the complex reflection coefficient, Γ_2 , of the termination on the output port.

When a moving short is used for the output termination, the magnitude of the ratio b_3/b_4 , which will also be called w , will remain at a constant (unit) value, while the phase depends upon the short position. If the real and imaginary values of w are plotted on a graph, they will thus lie on a circle of unit radius and with the center at the origin of the coordinate system. The curve (circle) which connects these points is called the locus of w .

If the couplers which form the reflectometer are no longer assumed to be ideal, w is no longer equal to Γ_2 . However the locus of w , when Γ_2 is a sliding short, is still a circle, but the radius and position of the center will differ from the

¹Directional couplers are represented by the normal waveguide convention (b_4 - incident waves, b_3 - reflected wave).

values given above. Let R represent the radius of the circle, and R_C the distance between its center and the origin. Then the locus of w (or b_3/b_4) will be as shown in figure 2.

These parameters (R, R_C) play a major role in the efficiency measurement to be described. First, however, although a complex ratio detector has been assumed in figure 1, it is possible to determine R and R_C with magnitude information only. By inspection of figure 2, if the magnitude of w is observed as the short is moved,

$$|w|_{\max} = R + R_C \quad (1)$$

$$|w|_{\min} = R - R_C \quad (2)$$

and,

$$R = \frac{1}{2}(|w|_{\max} + |w|_{\min}) \quad (3)$$

$$R_C = \frac{1}{2}(|w|_{\max} - |w|_{\min}) \quad (4)$$

The complex ratio detector can thus be replaced by one which measures only $|w|$. This will be described in greater detail in what follows.

There are a variety of practical measurement systems. One of these is shown in figure 3. Here it will be noted that the complex ratio detector has been replaced by a pair of power meters, and a pair of tuning transformers, T_x and T_y , have been added. Ordinarily, it is desirable to incorporate a leveling loop (not shown) such that the power, P_4 , in arm 4

is constant. When this is done only P_3 changes as the short is moved and R, R_C are given by,

$$R = \frac{1}{2}(\sqrt{P_{3\max}} + \sqrt{P_{3\min}})/\sqrt{P_4} \quad (5)$$

$$R_C = \frac{1}{2}(\sqrt{P_{3\max}} - \sqrt{P_{3\min}})/\sqrt{P_4} \quad (6)$$

(Note that the square roots are required because the powers are proportional to the square of the wave amplitudes.)

The output arm (2) of the reflectometer in figure 3 is terminated by the two-port whose efficiency is to be measured. The other end of the two-port is connected to the termination for which the efficiency is desired. (Note that the efficiency of a two-port depends upon the load to which it is delivering power.) The efficiency is measured by the following steps.

1) With the two-port and load connected as in figure 3, tuner T_x is adjusted such that $P_3 = 0$.

2) The termination is removed (from terminal 1, figure 3) and replaced by a sliding short.

3) $P_{3\max}$ and $P_{3\min}$ are observed as the short is moved, and R_1, R_{C1} are computed from (5) and (6). (Note that an additional subscript (1) has been added to indicate values measured at terminal 1. In a similar way, (2) will be used to refer to terminal 2 in figure 3.)

4) The two-port is removed, and a sliding short connected in its place at terminal 2.

5) R_2 and R_{C2} are determined from the new values of $P_{3\max}$ and $P_{3\min}$ as in step 3.

6) The efficiency, η_{al} , of the two-port is given by:

$$\eta_{al} = \frac{R_1 \left[1 - \left(\frac{R_{C1}}{R_1} \right)^2 \right]}{R_2 \left[1 - \left(\frac{R_{C2}}{R_2} \right)^2 \right]} \quad (7)$$

It should be noted that this expression involves only the ratios R_1/R_2 , R_{C1}/R_1 , and R_{C2}/R_2 . For this reason, if P_4 is constant it cancels from the efficiency expression and can be ignored in the computation of the value of R and R_C .

It is also possible to express the efficiency directly in terms of the observed quantities,

$$\eta = \frac{\sqrt{P_{31\max} * P_{31\min}} (\sqrt{P_{32\max}} + \sqrt{P_{32\min}})}{\sqrt{P_{32\max} * P_{32\min}} (\sqrt{P_{31\max}} + \sqrt{P_{31\min}})} \quad (8)$$

If leveling is not used, P_3 should be replaced by P_3/P_4 so that $P_{31\max}$ becomes $(P_{31}/P_{41})_{\max}$, etc.

Although the theory developed to this point accounts for the use of non-ideal directional couplers, an ideal (lossless) sliding short has been assumed. In actual practice, the losses in the short may be as large or larger than those in the two-port whose efficiency is to be measured. The

non-ideal behavior of the sliding short is thus a potential source of substantial measurement error unless properly taken into account. In the following paragraphs, the method for doing this is explained, first with an ideal sliding short and then with an actual one.

In figure 4, the power meters shown in figure 3 are combined in a meter which indicates the square root of their ratio so leveling is not required. It will also prove convenient to initially assume that the directional couplers and transformers T_x , T_y constitute an ideal reflectometer, so that the ratio meter indicates the magnitude of the reflection coefficient at the output arm. The object of the measurement is to determine the loss in a waveguide connector or joint in the output arm.

If the response of the ratio detector is plotted vs. the short position, one obtains a graph as shown in the inset of figure 4. This is explained as follows. When the short is to the left of the joint the reflection coefficient magnitude is always unity, although the phase is changing. Because the detector responds only to the magnitude, this accounts for the straight line portion of the graph. When the short moves to the right of the joint, the reflection coefficient magnitude will decrease because of joint losses. Moreover the extent of these losses will depend

upon the short position. As is well known, these losses are a maximum if the short position is a multiple of a half wavelength, and a minimum with the short midway between these positions. This accounts for the cyclic behavior to the right of the joint. On the basis of the prior discussion, the values of R_2 , R_1 , R_{C1} can be read from the graph as indicated. (Note that $R_{C2} = 0$ in this example.)

If this procedure is carried out in an actual system, the resulting graph is more nearly that shown in figure 5. Here the losses in the line, in which the short moves, superimpose a gradual decrease upon the response shown in figure 4 with increasing distance.

In order to eliminate the effect of line loss, it is only necessary to project the maxima and minima of the curve back to the plane of the joint and determine the values of R and R_C as shown in figure 5. (The theoretical basis for this is described in references [2,3].) In addition to losses in the line in which the "short" moves, it is also necessary to consider the effect of imperfect reflections from the moving "short" itself. Provided that, as in the above example, the same moving short is used on both sides of the two-port, the error approximately cancels and may ordinarily be neglected.

In other cases however, such as in the evaluation of a waveguide-coax adapter, it is obviously impossible to use the same short on both sides of the two-port (terminals 1

and 2 in figure 3). In this case it is desirable to make a pair of measurements. To be specific it will be assumed that terminal 2 in figure 3 is waveguide while terminal 1 is coaxial line. The first of the two measurements is carried out as already described.

For the second measurement it is convenient to use the system shown in figure 6. Although not explicitly indicated in the drawing, it is assumed that the two-port has been reversed so that terminal 2 is now coaxial while terminal 1 is waveguide. (Note that the system of figure 6 may be formed by a rearrangement of the components used in figure 3 with the addition of an appropriate adapter at the output port.) Although the use of this system is similar to what has already been described, there is a different procedure for adjusting T_x and a different formula for computing the efficiency.

The procedure is as follows.

- 1) The generator in figure 6 is temporarily removed and replaced by a passive load.

- 2) The generator which was removed in step 1 is now connected to terminal 2 and tuner T_y adjusted such that $P_4 = 0$.

- 3) Tuner T_x is now adjusted such that the impedance presented at terminal 2 is equal to that of the termination (Γ_ρ in figure 3) for which the efficiency is required. (Note that there are a variety of methods for recognizing the equality of two impedances.)

4) The system is next returned to the configuration shown in figure 6.

5) R_1 and R_2 are measured at terminals 1 and 2 as previously described.

6) The efficiency, η , is now given by the formula

$$\eta = R_1/R_2 \quad (9)$$

Provided that the losses in the waveguide and coaxial shorts are the same, these two methods will yield the same result. In practice the coaxial components usually have a substantially higher loss and one should use the square root of the product of the efficiencies as measured by these two different methods.

Step 2 above makes the first application of tuner T_y . This use however is incidental to its main purpose. In theory, the first of the described methods is independent of the adjustment of T_y . In the second it is used as an aid in recognizing the proper adjustment of T_x , but once this has been found, T_y may, in theory, be changed to a different value without affecting the result. The prime purpose of T_y is to keep the value of R_C within convenient limits. In figures 4 and 5, T_y has been adjusted such that $R_{C2} = 0$. Ordinarily this is unnecessary; as a general rule it is desirable to adjust T_y so that R_{C1} and R_{C2} are comparable to the difference between R_1 and R_2 . This helps minimize the dynamic range requirements on the recorder. The adjustment of T_y to satisfy this condition should follow the adjustment of T_x .

There are a large number of possible variants to the procedures outlined above. In particular it is not necessary to reverse the order of the couplers in the second of the two measurements. However if this is not done, a somewhat different tuning procedure is required, and the references should be consulted. Although the procedure for adjusting T_x has been quite explicit, it should be further noted that when the efficiency is large (close to unity) it also tends to be insensitive to variations in load impedance. Where the ultimate in accuracy is not required, it is often possible to ignore the tuning adjustment for T_x .

3. INSTRUMENTATION AND HARDWARE

As noted in the preceding section, the measurement system is basically a four-arm reflectometer with tuners. There are many variations to the way the directional couplers, tuners, or isolators can be configured. Two of these are shown in figures 3 and 6, a third is shown in figure 7. The components may be of a coaxial and/or waveguide type, and the detectors terminating arms 3 and 4 (reflected and incident detectors) are thermistor mounts for the technique described here.

The tuners in the reflectometer can be of several types such as capacitive screw waveguide or coaxial tuners, a directional coupler or Tee-junction with an attenuator and

sliding short on the sidearm, or an E-H Tee with sliding shorts. Tuners of the multi-screw type are commercially available although not to the extent of the other components in the system. The multi-screw tuners are the easiest to adjust for the type of tuning required for this measurement procedure and if designed properly will cover full waveguide bandwidths [4]. The directional coupler with a sidearm attenuator and sliding short is also well suited for the type of adjustments used in this measurement.

From this point on in the description of the measurement system and procedure, the four-arm reflectometer of figure 7 will be used. The reflectometer of figure 7 and figure 8 has the advantage of providing isolation of arm 4 from the reflected signal due to the sliding short at arm 2, which in turn reduces the amount of power leveling control necessary for the signal generator.

Figure 8 shows the measurement system with associated instrumentation. This configuration is only one of many which can be used, but is probably the easiest to set up with the usual laboratory equipment available. Commercially available power meters have been used on arms 3 and 4 and found to be quite adequate. The recorder output available on most power meters is then connected to the XY recorder. The power meters on arms 3 and 4 could also be the NBS Type II self-balancing bolometer bridges [5], in which case the external

leveling loop of arm 4 and the variable voltage source in the arm 3 circuit would not be required. In addition to the previously described components, figure 8 shows a position sensing device for the sliding short and a null detector which is optional. The null detector could be the power meter on arm 3 if a more sensitive detection system is not available. The null detection system for arm 3 could also be replaced by a spectrum analyzer or another type of microwave receiver.

The signal generator should be frequency stable and power leveled. Some power sources may have adequate frequency stability after warm-up to eliminate the necessity of frequency locking, but since there are tuning adjustments involved in the measurement technique it is suggested that an AFC circuit or phase locking of the signal generator be applied. Commercially available equipment should be adequate (frequency stability of 1 part in 10^6).

Power stability requirements depend on the value of loss to be measured. For example, if it is necessary to measure a 0.001 dB loss, the short-term power instability should be at least an order of magnitude less, or 0.0001 dB. Ordinarily, to achieve this the signal source is power leveled using the thermistor mount on arm 4 of the reflectometer as a detector. This can be accomplished by using the leveling

capability on most modern signal generators, such as swept frequency generators which have PIN diode modulators as part of the rf output, in combination with the recorder output of the arm 4 power meter. The particular hook-up of the leveling loop will vary with equipment used, and manufacturers instructions should be followed. Here again commercially available power meters with a recorder output have been found to be adequate. The configuration of figure 7 reduces effects of the sliding short on the power level at arm 4, and if the generator itself is stable enough (for the loss to be measured) the leveling loop can be eliminated.

Figure 9 shows two basic configurations for sliding shorts. The sliding short circuit should be of the non-contacting variety to eliminate noise in the measurement. Commercially available sliding shorts are adequate as long as they will move through connector joints and are not "noisy" (do not show large changes in reflection coefficient as they are moved in a transmission line). In waveguide, a good sliding short is the "dumbbell" type. The cylindrical dumbbell section diameters should be as close as possible to the inside narrow dimension of the waveguide without actually contacting. The dumbbell length and spacing can be about $1/4$ guide wavelength at a frequency slightly above the highest frequency of the waveguide band. Three dumbbell sections are adequate. Coaxial sliding shorts can be constructed in a

similar fashion. Quarter wavelength coaxial choke sections (two or three sections) also make good non-contacting shorts. The reflection coefficient of the sliding short should be at least 0.95 and preferably greater than 0.99. The waveguide short can also be made by using high conductivity slugs inserted in a dielectric block which is made to fit the inside waveguide dimensions [6]. The coaxial short of the type shown in figure 9 will usually be adequate for frequencies below the design frequency. For example, if the quarter-wave sections are cut for 8 GHz, the short will have a high reflection coefficient over the band 4 to 8 GHz. Sliding shorts of the above type for waveguide are available.

For recording the level of power in arm 3 vs. short position, a mechanism for converting position to voltage is necessary. Depending upon the amount of travel involved (which in turn depends upon the signal frequency) it may be possible to mechanically couple the short to a linear potentiometer. Otherwise one must devise a geared or belted mechanism which converts linear position to rotation (of gear or pulley wheel), which in turn drives a potentiometer. The potentiometer is excited with some constant voltage dc source and the center tap provides a voltage proportional to short position.

An XY recorder is used for displaying differential changes in P_3 vs. short position. The recorder output voltage from the arm 3 thermistor power meter is applied to a resistor along with another stable voltage which is adjustable. The connection of voltages should be made in such a way that the voltage to the XY recorder is the difference between the power meter output voltage (≈ 1 volt) and the adjustable voltage as shown in figure 8. In this way, the recorder can be operated on a low voltage range to increase sensitivity. The recorder amplifier should be capable of displaying millivolt range voltages for the P_3 fluctuations.

The potentiometer driving voltage -- for sliding short position -- is adjusted to give some convenient reference scale (one inch on recorder plot for one inch travel of sliding short, for example) on the recorder chart. The X or Y axis can be used to display power fluctuations, but for maximum resolution the longest physical dimension of the XY chart should be used for the power meter connection. The voltage source used in the arm 3 and short position circuits can be simply a battery-potentiometer combination. With the NBS Type II power meters, the reference voltage generator provides a highly stable voltage source for this purpose.

If used the low level detection receiver is also connected to arm 3 via a directional coupler for the T_x tuner adjustment. A directional coupler with a local oscillator on the sidearm and crystal mixer on the main arm used in conjunction with an IF amplifier is adequate. The null detection system or the arm 3 power meter are used to make P_3 equal to zero for the T_x adjustment described in the previous section. Alternate adjustments of the tuning elements are made, each time reducing the P_3 indicator to a minimum.

The XY recorder is used to detect fluctuations in P_3 for the adjustment of T_y and in measuring R and R_C as described in Section 2. With the power on, and a sliding short replacing the load for the T_x tuning, the variable voltage source in the arm 3 recorder output circuit is adjusted, along with the X input sensitivity, to display the power fluctuations as the sliding short is moved near the output or input of the two-port. It may be necessary to remove the two-port to do this. Some two ports (coax to waveguide adaptors) require two different types of shorts for the input and output ports. Tuner T_y is adjusted so that fluctuations on the recorder are minimized. The recorder chart will give a display similar to figures 10 and 11. The sensitivity on the X channel should be adjusted to allow maximum resolution. It may be necessary to alternate the sliding short between input and output of the two port, making adjustments in T_y and X channel

sensitivity until the full chart length is utilized. The smooth portions of the plot, as in figures 10 and 11, will generally occur when the sliding short is in a uniform section of transmission line such as the input or output leads of the two-port or the leads preceding or following the two-port. Some experimentation with the T_y tuning may be necessary to determine an optimum setting so that high resolution and uniformity of the trace is obtained. The envelope of the P_3 plot will in general be parallel lines if T_x is tuned with $\Gamma_\ell = 0$. When efficiencies for other load conditions are desired, or when the two-port is itself highly reflective, the envelope will tend to have other forms, and the extrapolation of the envelope to connector reference planes requires more care.

Once T_x and T_y have been adjusted the X scale can be calibrated in terms of power level as shown in figure 11. This is done by correlating the reading of the P_3 power meter with the recorder output voltage. If a full scale reading on the power meter of 10 milliwatts gives a voltage at the recorder output of one volt, and the nominal value of P_3 with the sliding short at port 2 is 5 milliwatts, the variable voltage source is set to 0.5 volts giving an X channel difference voltage of zero volts when P_3 is 5 milliwatts. If the X channel sensitivity is set at 5 millivolts/inch, one inch on the recorder chart corresponds to 0.005×10 milliwatts

per volt or 0.05 milliwatts variation about the point representing 5 milliwatts. Another way of looking at this calibration procedure is to set the short so that P_3 on the power meter is exactly 5 milliwatts. Then the variable voltage source is adjusted so that the X channel input voltage is zero. Now, by offsetting the recorder zero to perhaps midscale, one inch on either side of this reference line will be 4.95 and 5.05 milliwatts for P_3 . In this way the variable voltage source is left fixed, and variations in P_3 due to sliding the short can be read off the XY plot. If the NBS Type II power meters are used, the X channel voltage can be obtained from the delta voltage connection on the power meter. The reference voltage generator in the Type II system is then adjusted to give small delta voltages and the P_3 scale calibrated in terms of bridge voltage instead of power level. Power calculations are made using bridge voltage with power on using the calibrated scale, the bridge voltage without power as described in the operating instructions for the Type II system. A reference line is obtained by setting the reference voltage generator so that the delta voltage is zero for some fixed position of the sliding short. The dial reading of the reference voltage generator is then recorded and variations above and below this point are derived by adding or subtracting the distance on the chart times the

sensitivity of the X channel. For example, a 5 millivolt/inch X channel sensitivity would mean that one inch above the reference line would indicate a bridge voltage of the reference dial reading plus 0.005 volts.

It should be noted that the input and output leads of the two-port may be of different size or type of transmission line, as in the case of the coax-to-waveguide adaptor. In this case, there are two different sliding shorts used in the input and output for transmission lines as shown in figure 11. When this condition exists the two-port efficiency must be measured in both directions and the two efficiencies averaged as described in Section 2.

Using figure 11 as an example, the efficiency of the two-port is calculated using $(P_{3\max})_1$ and 2 and $(P_{3\min})_1$ and 2 which are determined by the intersection of the envelope of the P_3 curve with the input and output connection planes of the device under test. The values for P_3 are obtained using the calibrated scale. First four constants R_1 , R_2 , R_{C1} , and R_{C2} are calculated using equations (5) and (6) in Section 2. For the example in figure 5 these values become:

$$\begin{aligned}R_2 &= 2.2375 \\R_1 &= 2.2319 \\R_{C2} &= 0.0014 \\R_{C1} &= 0.0008\end{aligned}$$

The efficiency of the two-port for power flow from port 2 to 1, with a load at 1 as determined by the adjustment of tuner T_x , is calculated using (7). Using the example,

$$\eta_{al} = 0.9975$$

Converted to a dB loss η_{al} becomes $10 \log \eta_{al}$ or -0.0109 dB for the example. For the case where $\Gamma_\ell = 0$ in the T_x adjustment, this loss is equivalent to insertion loss.

For the measurement of waveguide or coaxial flanges or connectors, position planes 1 and 2 in figure 11 become the same plane or nearly so. (Type N connectors do not have a fixed reference plane, but inner and outer conductor joints spaced slightly apart.)

The location of flange or connector joints is easier to identify by observing the XY-trace since discontinuities show up as a marked perturbation on the trace. It is harder to know the physical location of the sliding short reference plane as this will vary with frequency, so an examination of the XY-plot is the best way of locating reference planes for the extrapolation of the envelope to determine P_{\max} and P_{\min} .

For best results it is desirable to make repeated measurements using slightly different tuner settings for T_y . The variation in results will give a good indication of measurement precision. As a rule one would like to have the standard deviation of the measurements an order of magnitude less than the actual loss measured. If this is not the case, more

sensitivity can be used for the P_3 difference voltage. It is not uncommon, when using two different sliding shorts, to have the average loss measured for one direction of power flow through the two-port to be quite a bit different from the loss measured with power flow in the other direction, although the repeatability of loss in any one direction should still be small.

4. SUMMARY

The techniques outlined above have proven a useful tool at NBS and other well equipped laboratories. It is hoped that this report will bring the benefits of these measurement procedures within the scope of a larger number of users.

5. ACKNOWLEDGMENT

This report was sponsored by the Department of Defense, Calibration Coordination Group.

6. REFERENCES

- [1] Beatty, R.W., G.F. Engen and W.J. Anson, Measurement of Reflections and Losses of Waveguide Joints and Connectors Using Microwave Reflectometer Techniques, IRE Trans. Instr. & Meas., Vol. I-9, No. 2, September 1960.
- [2] Almasy, G., A First Order Correction to Sliding Short Behavior with Application to the Problem of Measuring Small Losses, IEEE Trans. Instr. & Meas., Vol. IM-20, August 1971.
- [3] Engen, G.F., An Extension to the Sliding Short Method of Connector and Adapter Evaluation, Journal of Research, NBS, Vol. 75C (Eng. and Instru.), Nos. 3 and 4, pp. 177-183, July-December 1971.
- [4] Weidman, M.P., A Method for Designing Multi-Screw Waveguide Tuners, NBS Technical Note 393, October 1970.
- [5] Larsen, N.T. and F.R. Clauge, The NBS Type II Power Measurement System, Proc. of 25th ISA Annual Conference and Concurrent Symposia, Vol. 25, pp. 712-770, October 1970.
- [6] Larson, W. and R. Hunter, A Broadband Noncontacting Sliding Short, NBS Technical Note 602, June 1971.

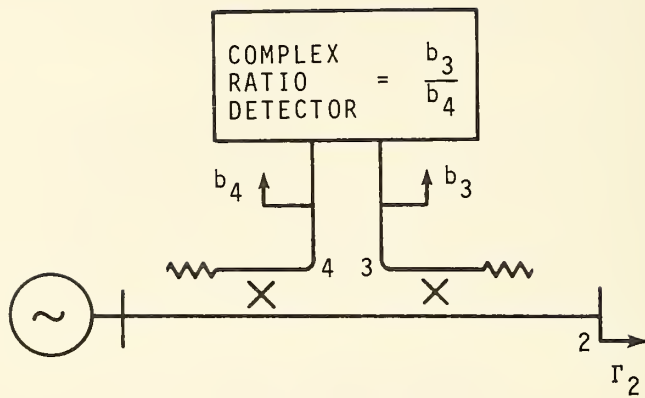

Figure 1. An ideal reflectometer which measures complex reflection coefficient.

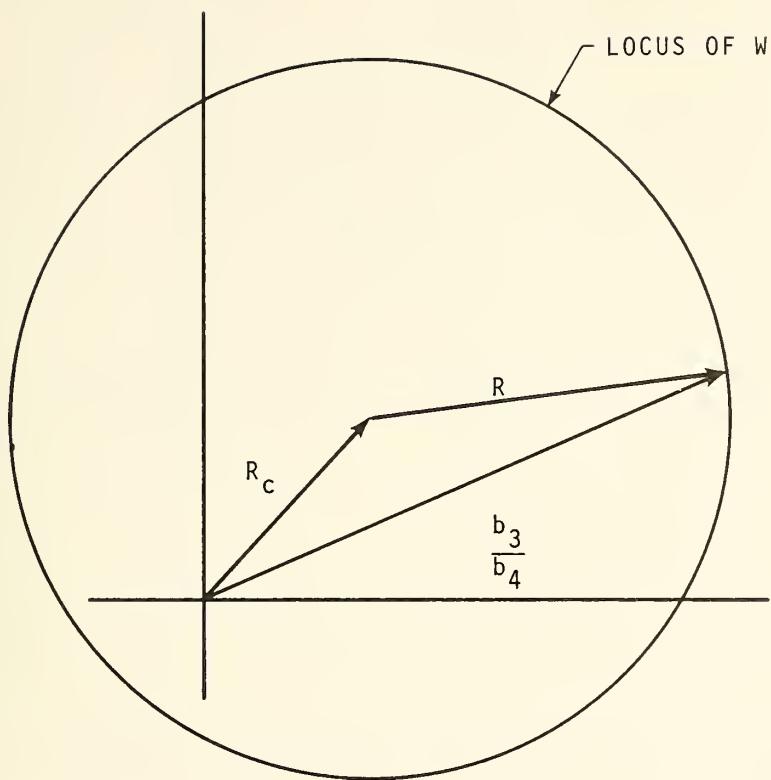

Figure 2. Locus of w for a non-ideal reflectometer.

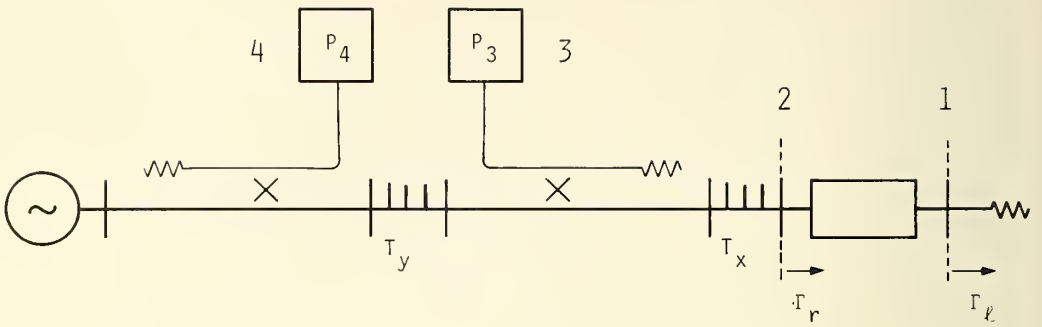

Figure 3. A practical measurement system using non-ideal components.

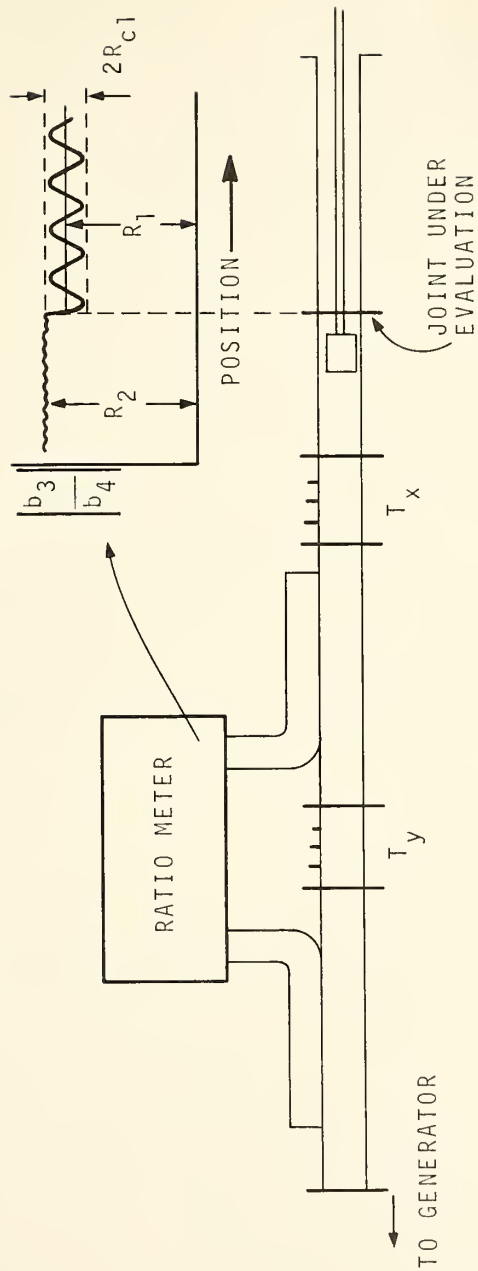

Figure 4. Response of system using an ideal sliding short.

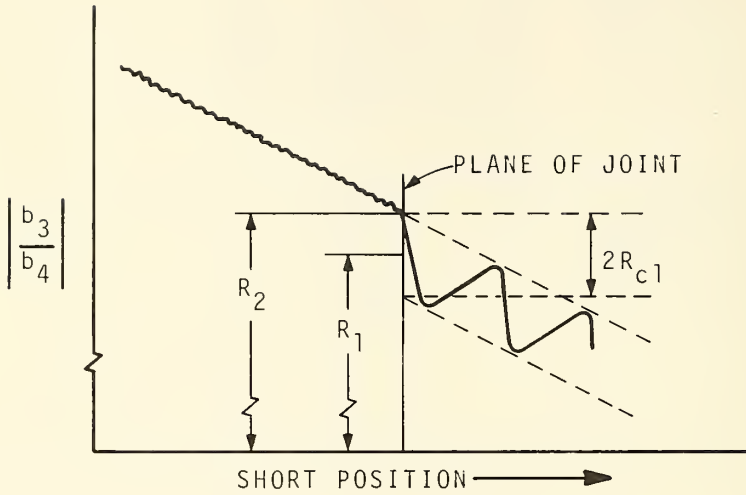

Figure 5. Actual response of system showing effect of short losses.

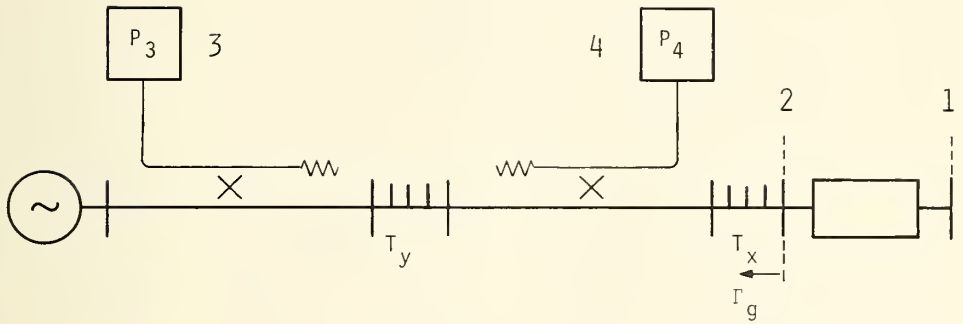

Figure 6. Alternative form of measurement system.

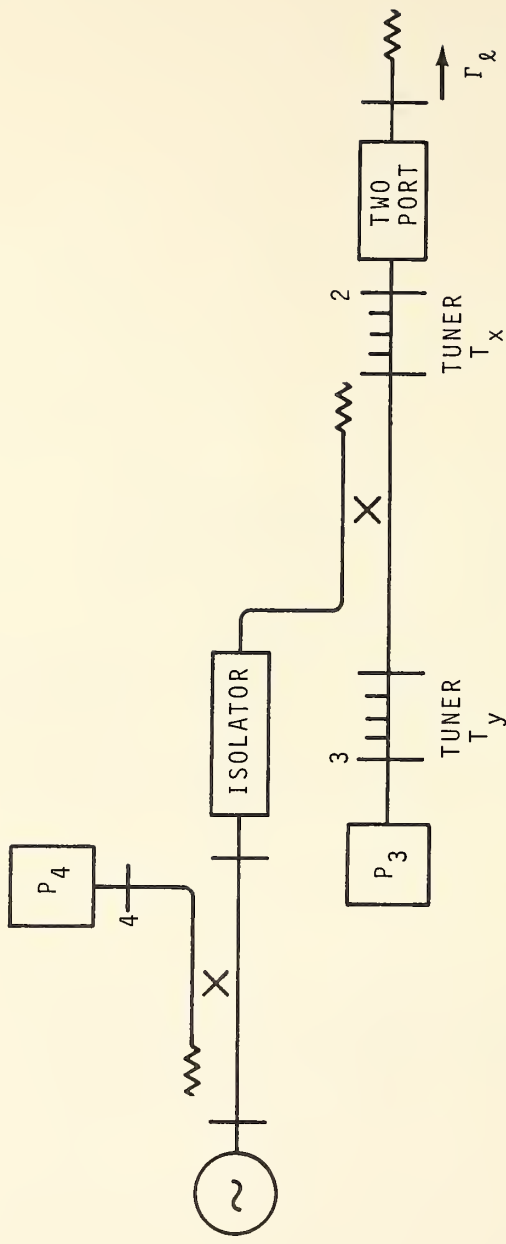

Figure 7. A third example of a tunable 4-arm reflectometer for measuring 2-port efficiency.

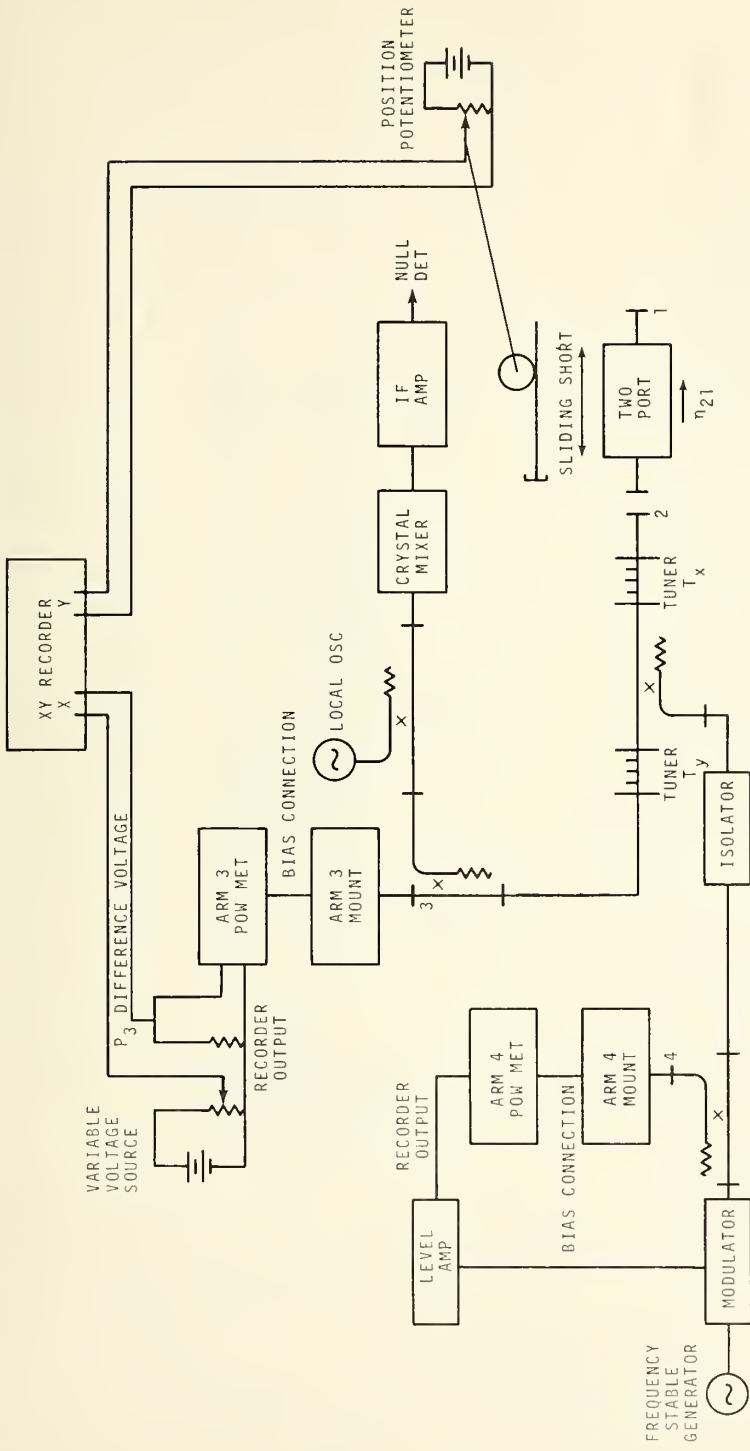

Figure 8. Measurement system for evaluating 2-port efficiency.

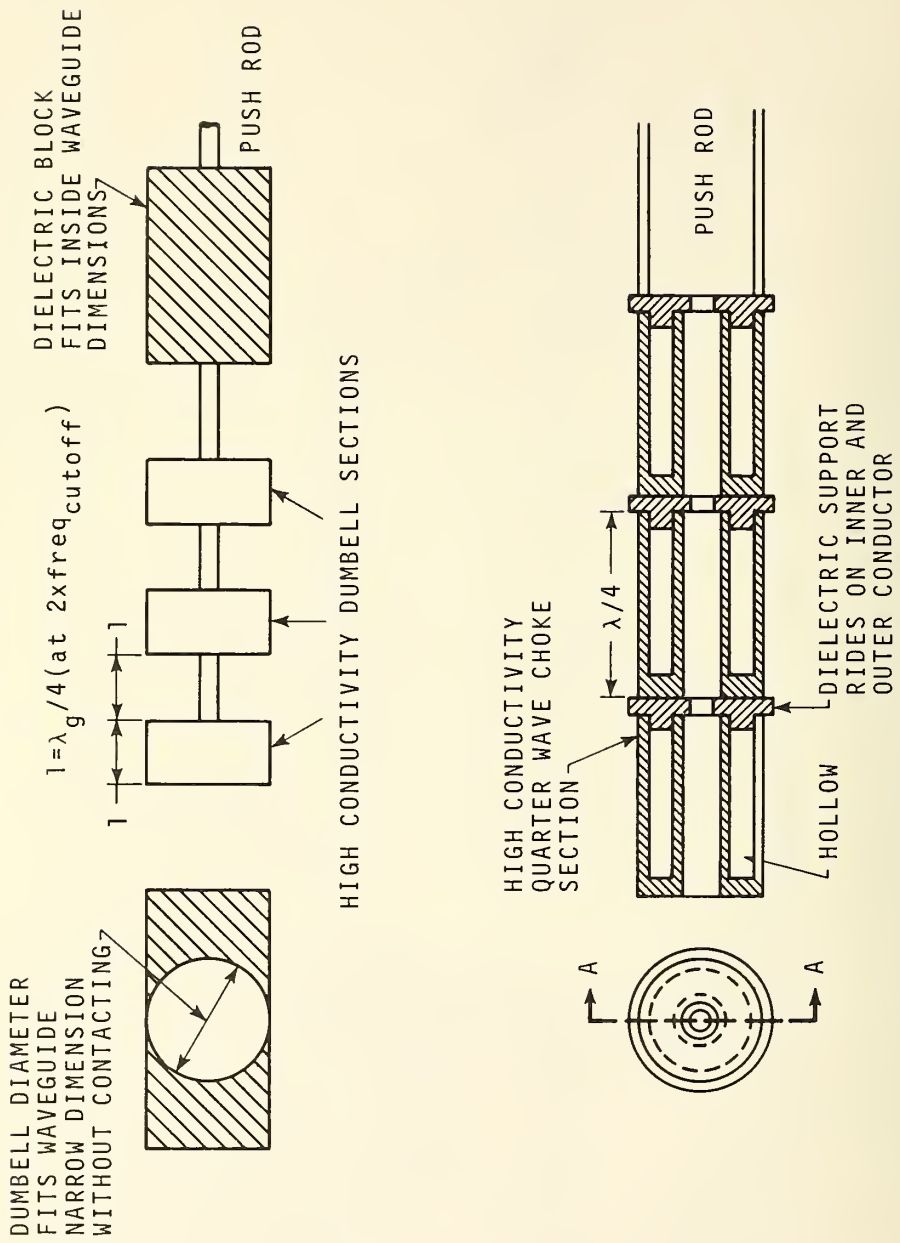

Figure 9. Examples of two non-contacting sliding shorts.

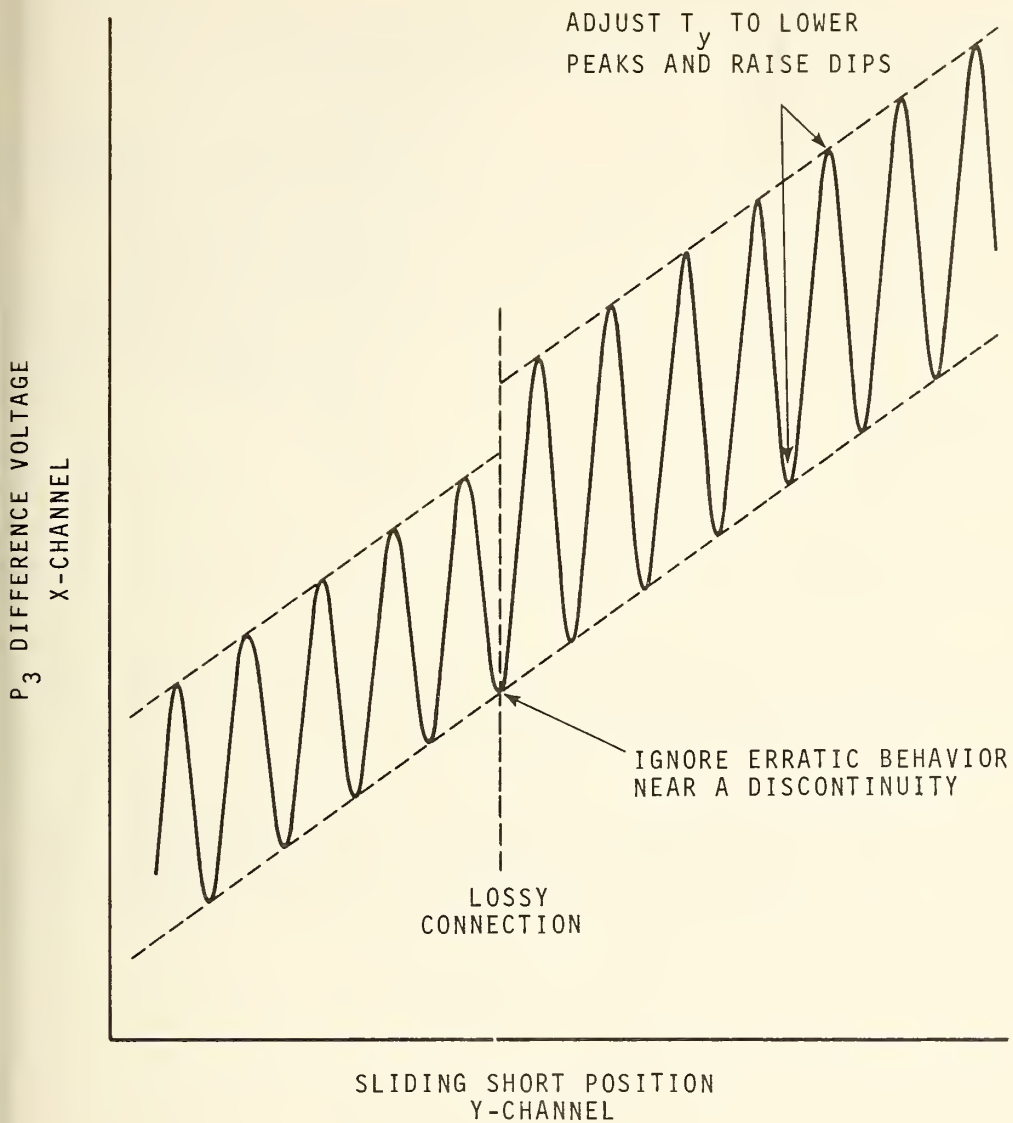

Figure 10. Plot of P_3 vs. sliding short position for T_y tuning.

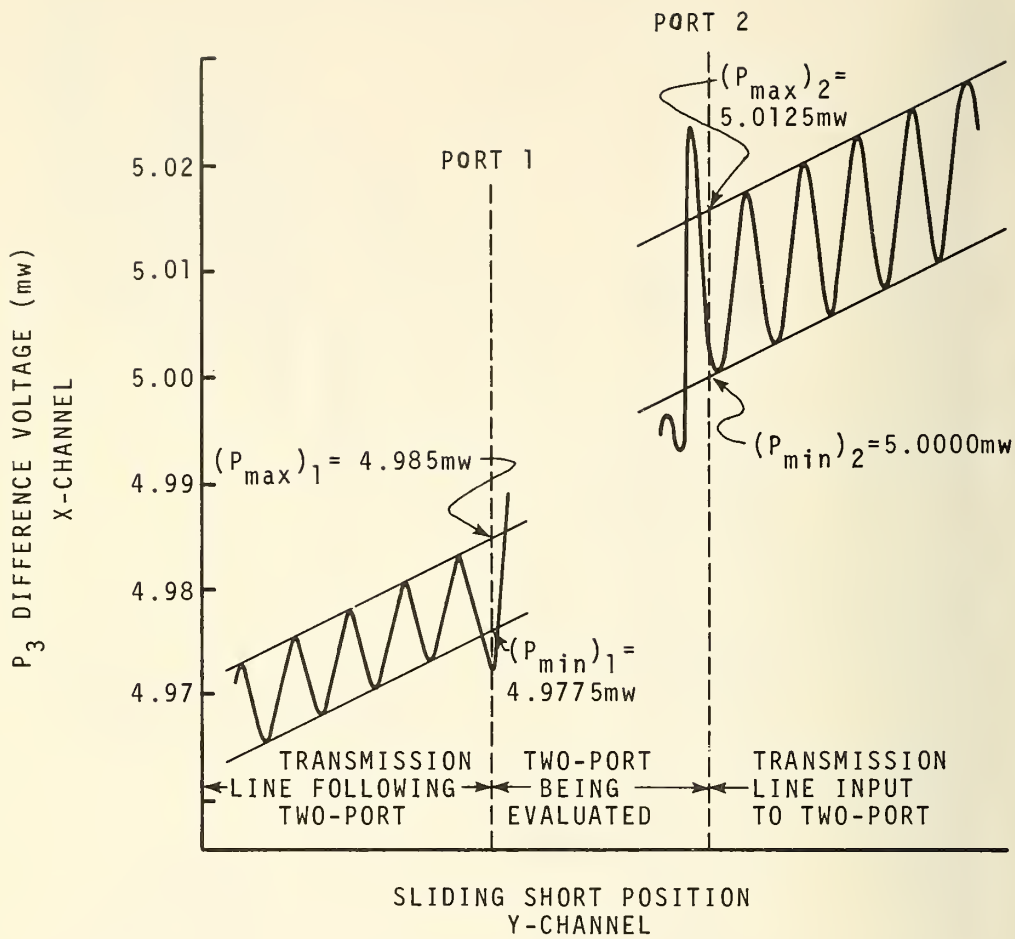

Figure 11. Calibrated XY-plot for calculating 2-port efficiency.

| | | | |
|---|--|--|---------------------------------|
| U.S. DEPT. OF COMM. BIBLIOGRAPHIC DATA SHEET | 1. PUBLICATION OR REPORT NO. NBS Technical Note 644 | 2. Gov't Accession No. | 3. Recipient's Accession No. |
| 4. TITLE AND SUBTITLE APPLICATION OF A NON-IDEAL SLIDING SHORT TO TWO-PORT LOSS MEASUREMENT | | 5. Publication Date October 1973 | 6. Performing Organization Code |
| 7. AUTHOR(S) M. P. Weidman and G. F. Engen | | 8. Performing Organization | |
| 9. PERFORMING ORGANIZATION NAME AND ADDRESS NATIONAL BUREAU OF STANDARDS, Boulder Labs. DEPARTMENT OF COMMERCE Boulder, Colorado 80302 | | 10. Project/Task/Work Unit No. 2721393 | 11. Contract/Grant No. |
| 12. Sponsoring Organization Name and Address Department of Defense Calibration Coordination Group | | 13. Type of Report & Period Covered | 14. Sponsoring Agency Code |
| 15. SUPPLEMENTARY NOTES | | | |
| <p>16. ABSTRACT (A 200-word or less factual summary of most significant information. If document includes a significant bibliography or literature survey, mention it here.)</p> <p>A detailed, applications-oriented, description of a method for measuring two-port losses is given. The technique involved uses a non-ideal sliding short circuit and a tuned four-arm reflectometer. Most, if not all, of the components used in this technique can be put together using commercially available items. It is the intent of this discussion to provide enough detail and explanation so that a technician with some working knowledge of microwave measurements can set up and make loss measurements.</p> <p>The reference made to two-ports implies a broad range of devices from a simple flange or connector to waveguide coaxial adaptors and even more elaborate configurations with a definable input and output connection.</p> | | | |
| 17. KEY WORDS (Alphabetical order, separated by semicolons) short; two-port. Efficiency; loss; reflectometer; sliding | | | |
| 18. AVAILABILITY STATEMENT <input checked="" type="checkbox"/> UNLIMITED. <input type="checkbox"/> FOR OFFICIAL DISTRIBUTION. DO NOT RELEASE TO NTIS. | | 19. SECURITY CLASS (THIS REPORT) UNCLASSIFIED | 21. NO. OF PAGES 40 |
| | | 20. SECURITY CLASS (THIS PAGE) UNCLASSIFIED | 22. Price \$.50 |



NBS TECHNICAL PUBLICATIONS

PERIODICALS

JOURNAL OF RESEARCH reports National Bureau of Standards research and development in physics, mathematics, and chemistry. Comprehensive scientific papers give complete details of the work, including laboratory data, experimental procedures, and theoretical and mathematical analyses. Illustrated with photographs, drawings, and charts. Includes listings of other NBS papers as issued.

Published in two sections, available separately:

• Physics and Chemistry (Section A)

Papers of interest primarily to scientists working in these fields. This section covers a broad range of physical and chemical research, with major emphasis on standards of physical measurement, fundamental constants, and properties of matter. Issued six times a year. Annual subscription: Domestic, \$17.00; Foreign, \$21.25.

• Mathematical Sciences (Section B)

Studies and compilations designed mainly for the mathematician and theoretical physicist. Topics in mathematical statistics, theory of experiment design, numerical analysis, theoretical physics and chemistry, logical design and programming of computers and computer systems. Short numerical tables. Issued quarterly. Annual subscription: Domestic, \$9.00; Foreign, \$11.25.

TECHNICAL NEWS BULLETIN

The best single source of information concerning the Bureau's measurement, research, developmental, cooperative, and publication activities, this monthly publication is designed for the industry-oriented individual whose daily work involves intimate contact with science and technology—for *engineers, chemists, physicists, research managers, product-development managers, and company executives*. Includes listing of all NBS papers as issued. Annual subscription: Domestic, \$6.50; Foreign, \$8.25.

NONPERIODICALS

Applied Mathematics Series. Mathematical tables, manuals, and studies.

Building Science Series. Research results, test methods, and performance criteria of building materials, components, systems, and structures.

Handbooks. Recommended codes of engineering and industrial practice (including safety codes) developed in cooperation with interested industries, professional organizations, and regulatory bodies.

Special Publications. Proceedings of NBS conferences, bibliographies, annual reports, wall charts, pamphlets, etc.

Monographs. Major contributions to the technical literature on various subjects related to the Bureau's scientific and technical activities.

National Standard Reference Data Series. NSRDS provides quantitative data on the physical and chemical properties of materials, compiled from the world's literature and critically evaluated.

Product Standards. Provide requirements for sizes, types, quality, and methods for testing various industrial products. These standards are developed cooperatively with interested Government and industry groups and provide the basis for common understanding of product characteristics for both buyers and sellers. Their use is voluntary.

Technical Notes. This series consists of communications and reports (covering both other-agency and NBS-sponsored work) of limited or transitory interest.

Federal Information Processing Standards Publications. This series is the official publication within the Federal Government for information on standards adopted and promulgated under the Public Law 89-306, and Bureau of the Budget Circular A-86 entitled, Standardization of Data Elements and Codes in Data Systems.

Consumer Information Series. Practical information, based on NBS research and experience, covering areas of interest to the consumer. Easily understandable language and illustrations provide useful background knowledge for shopping in today's technological marketplace.

BIBLIOGRAPHIC SUBSCRIPTION SERVICES

The following current-awareness and literature-survey bibliographies are issued periodically by the Bureau:

Cryogenic Data Center Current Awareness Service (Publications and Reports of Interest in Cryogenics).

A literature survey issued weekly. Annual subscription: Domestic, \$20.00; foreign, \$25.00.

Liquefied Natural Gas. A literature survey issued quarterly. Annual subscription: \$20.00.

Superconducting Devices and Materials. A literature survey issued quarterly. Annual subscription: \$20.00.

Send subscription orders and remittances for the preceding bibliographic services to the U.S. Department of Commerce, National Technical Information Service, Springfield, Va. 22151.

Electromagnetic Metrology Current Awareness Service (Abstracts of Selected Articles on Measurement Techniques and Standards of Electromagnetic Quantities from D-C to Millimeter-Wave Frequencies). Issued monthly. Annual subscription: \$100.00 (Special rates for multi-subscriptions). Send subscription order and remittance to the Electromagnetic Metrology Information Center, Electromagnetics Division, National Bureau of Standards, Boulder, Colo. 80302.

Order NBS publications (except Bibliographic Subscription Services) from: Superintendent of Documents, Government Printing Office, Washington, D.C. 20402.

U.S. DEPARTMENT OF COMMERCE
National Bureau of Standards
Washington, D.C. 20234

OFFICIAL BUSINESS

Penalty for Private Use, \$300

POSTAGE AND FEES PAID
U.S. DEPARTMENT OF COMMERCE
COM-215

