

200
100
5753
529
10

UNITED STATES DEPARTMENT OF COMMERCE
Maurice H. Stans, Secretary

NATIONAL BUREAU OF STANDARDS • Lewis M. Branscomb, Director



7
TECHNICAL NOTE 539

ISSUED OCTOBER 1970

Nat. Bur. Stand. (U.S.), Tech. Note 539, 20 pages (Oct. 1970)
CODEN: NBTNA

**Improvements in Oscilloscopic Measurements
in High-Speed Experiments**

A. Cezairliyan, M. S. Morse, and H. A. Berman

Physical Chemistry Division
Institute for Materials Research
National Bureau of Standards
Washington, D.C. 20234



NBS Technical Notes are designed to supplement the Bureau's regular publications program. They provide a means for making available scientific data that are of transient or limited interest. Technical Notes may be listed or referred to in the open literature.

Contents

	Page
1. Introduction	1
2. Description of the System	2
2. 1. Differential Suppression	
2. 2. Time Synchronization	
3. Experimental Arrangement and Operation	3
4. Oscillogram Measurements and Calculations	5
5. Results and Discussion	7
6. Conclusions	9
7. References	9

Improvements In Oscilloscopic Measurements In High-Speed Experiments*

A. Cezairliyan, M. S. Morse, and H. A. Berman

Two refinements in oscilloscopic recording have been made which improve considerably the recording of isolated events in heavy current discharge studies, where substantially rectangular pulses are employed. The accuracy of the method employed has been verified experimentally to be in the region of 0.01 to 0.1 percent. The first refinement is a unit for the differential suppression of the incoming signal by an adjustable amount, and the second refinement is a system by which time markers are sent to several oscilloscopes at adjustable time intervals simultaneously with the actual incoming signal.

Key words: High-speed measurements; high-speed recording; oscilloscopes.

1. Introduction

Oscilloscopes in themselves are not accurate recording instruments. Under the most favorable conditions, that is with adjustments for linearity and prior calibrations, the accuracy of the beam position is about 1 percent. Additional difficulties result when more than one oscilloscope is required for the simultaneous recording of several quantities, for example in work involving single heavy discharges. Although the same pulse may be used for triggering all oscilloscopes, experience has shown that differences between oscilloscopes, even of the same make and model, may cause differences in the time scale zero. Further errors may be caused by differences in sweep linearity.

In this study two refinements in oscilloscopic recording have been made which have reduced the recording inaccuracy to 0.1 percent or better. The first is a unit for the differential suppression of the incoming signal by an adjustable amount, and the second is a system by which time markers are sent to every oscilloscope simultaneously with the actual incoming signals. Extensive experimental work has been done to confirm the accuracy of the method and equipment used.

*This work was supported in part by the Propulsion Division of the U. S. Air Force Office of Scientific Research under contract ISSA-69-0001.

The motive in undertaking this study was to improve the recording accuracy and resolution in millisecond experiments in which thermo-physical properties of matter are measured at high temperatures.

2. Description of the System

2. 1. Differential Suppression

The circuit diagram of a differential voltage suppression unit designed for a maximum voltage of 9 volts is shown in figure 1. It will be noted in figure 2 that the suppression unit is connected to the observation point through a high-speed mercury relay. While physically separated, the relay is an essential part of the suppression system, since it enables the oscilloscope amplifier to remain under normal operating conditions (where the oscilloscope trace is within the screen area) until a time just prior to the pulse, or portion of the pulse, to be observed.

The operation of the oscilloscope amplifiers under cut-off conditions is thus avoided. All oscilloscope amplifiers with which the authors are familiar, including those with built in suppression facilities, drift severely during cut-off conditions. In addition, amplifiers with built in suppression facilities are not available with differential inputs, thus rendering them essentially useless for work of this nature, where the reference point is by necessity above ground by a variable amount.

The mercury relays used are capable of operating within a time of approximately a millisecond, and are reproducible to about 0. 1 millisecond. As in most discharge work, the time of the pulse occurrence is approximately known, so that the relays may operate in advance of the pulse if desired.

It must be noted that a voltage suppression is effective only in cases where the portion of the transient voltage to be examined does not vary considerably with time; in other words, when the waveform is of rectangular or flat trapezoidal shape. In these experiments it has been possible to suppress 90 to 99 percent of the incoming voltage signals. Since the suppression voltage is constant, it can be measured very accurately under steady-state conditions by a potentiometer. The oscilloscope inaccuracies are therefore applicable only to the unsuppressed portion of the signal.

2. 2. Time Synchronization

The most effective way of insuring a one-to-one correspondence between the simultaneous points on the traces of every oscillogram is to provide a means of making the same time signals on every oscillogram during the transient experiment. A modified time-mark generator was

used to achieve this. Its output was fed into the oscilloscope vertical amplifiers. This scheme provided small, sharp dots or vertical spikes at regular time intervals on the oscilloscope signal traces. The frequency of the time markers could be selected according to the duration of the experiment.

Two major modifications in the time-mark generator were made. An amplifier and a pulse-length control unit were installed to adjust the amplitude and the duration of the markers, and a gate unit to start the markers at a given time. Events on different oscillograms were thus provided with a common time base and uncertainties arising from the triggering of the beams of different oscilloscopes and from nonlinearities of the time scales could thereby be reduced to a negligible level.

3. Experimental Arrangement and Operation

To assess the operational characteristics of the system described, the value of a test resistor was determined by measuring the current flowing through it and the voltage drop across its terminals under transient conditions and comparing this measurement with its resistance under steady-state conditions as determined by the potentiometric method.

The experimental arrangement is shown schematically in figure 2. The main circuit was designed for high pulse currents (up to 5000 A). The value of the pulse current was obtained by measuring the potential across a reference resistor (0.001Ω). This reference resistor consisted of a manganin strip bent into a single hairpin. Calculations indicated that skin effects and inductance were negligible at the frequencies involved in this work. The test resistor was an Inconel tube (230 mm long, 25 mm O. D., 3.1 mm thick).

Because of the very low resistance, the high thermal capacity of the electrical system, and the relatively stable power source (a 28 V battery bank of 1200 ampere-hours capacity), current flowing through the circuit did not change appreciably during the short pulse. This implies that the current pulse was of rectangular form. In order to simulate actual heating conditions in a test specimen in which the current decreases with time as the resistance increases with temperature, a trapezoidal current pulse was obtained by inserting a tungsten strip (100 mm long, 6.2 mm wide, 0.5 mm thick) in series with the test resistance. The slope of the top of the trapezoidal pulse is then determined mainly by the characteristics of the tungsten strip.

Experiments were conducted both with and without the tungsten strip in the circuit. Figure 3 shows oscillogram reproductions of two typical cases of rectangular and trapezoidal pulses. For each case, the complete pulse is shown as well as the partial recording after suppression of the major portion of the pulse. The partial recording is on a

more sensitive scale. The actual oscillogram of a trapezoidal pulse with and without suppression is shown in figure 4.

Because of the short duration of the current pulses, all operations were synchronized with the aid of time-delay units. As may be seen in figure 2, after manual triggering, the main switch was closed and the current pulse was sent through the system. At this point, the voltage developed across the test resistor triggered a voltage detector, which sent a signal to the time-delay unit to trigger the oscilloscopes and operate the mercury switches and the time-mark generator. The time sequence of major events in an experiment is shown in figure 5. The mercury switches prevented the error caused by overload conditions (which can amount to several millivolts) by keeping the beam on the screen at all times and preserving the position of the base line. Before the pulse current was triggered and after it was terminated, the mercury switches were open, isolating the circuit from the suppression voltage. During the pulse, they were closed so that the oscilloscopes sensed only the difference between the source voltage and the suppression voltage. In addition, the mercury switches provided superposition of the base line of the actual pulse with that obtained under zero signal conditions, as may be seen in figure 6. The two base lines obtained at slightly different times were thereby compared and a correction could be made in the event of a difference between them.

Two oscilloscopes instead of a dual-beam oscilloscope were intentionally used in the tests. The time scales of the oscilloscopes were set on arbitrary "uncalibrated" positions so that the experimenter could rely completely on the time markers in correlating the corresponding current and voltage signals. Since the same time markers appeared on both signal traces, non-linearities in the time scales did not cause any errors; in fact, it was not even necessary to calibrate the oscilloscope time scales.

The oscilloscopes used in the experiment were electrically isolated from each other by means of isolation transformers at the power-line connections. Isolation transformers were also used ahead of all other inputs, such as trigger signals and time-marker signals. It was found that neglect of such precautions introduced stray currents and erroneous signals. Each oscilloscope was completely floating electrically and its relative ground (reference) point was at the negative potential of either the reference or the test resistor.

A permanent record of the signal traces was made by photographing the oscilloscope screen. The traces on the oscillograms thus obtained were measured with the use of a micrometer microscope, and the measurements corrected as described in Section 4.

The foregoing paragraphs have presented the experimental arrangement for measuring the value of a test resistor under pulse conditions, and comparing it with its value under steady-state conditions. However, to measure certain thermodynamic quantities under transient

conditions, it is necessary to know the power imparted to the specimen as a function of time. Although both resistance and power are obtained through the measurement of the same two variables, the errors associated with them may be different from each other inasmuch as one is represented by a quotient, the other by a product. If the systematic errors in voltage and current are in the same direction, the resulting relative error in resistance will be the difference between these relative errors, whereas the corresponding power error will be their sum; conversely, if these errors are of opposite sign, the resistance error will be their sum and the power error their difference.

An additional experiment was performed to assess the errors involved with the high-speed measurement of one quantity, such as current or voltage. In this experiment the same basic circuit as that given in figure 2 was used. The original 0.001 Ω reference resistor was replaced by one of 0.1 Ω . A direct current of approximately 12 A was allowed to flow under steady-state conditions through the main circuit. The potential across the reference resistor was measured with a potentiometer, and, at the same time, recorded with the improved oscillographic technique following the procedure developed for the pulse experiments. The comparison of the two results obtained by the two different methods gives the accuracy of the high-speed recording of one variable under quasi-pulse conditions. This procedure was used separately to check each of the two oscilloscopes. The only difference between this quasi-pulse method and that of a pulse experiment is the absence of possible fields and skin effects. It is shown in Section 5 that errors of this origin are negligible.

Thus, the results of two separate experiments, (1) pulse experiments yielding a comparison of steady-state resistance with that under pulse conditions, and (2) quasi-pulse experiments yielding a comparison of one quantity under steady-state and quasi-pulse conditions, determine the accuracy of measurement of the quantities in transient experiments by the improved oscillographic technique.

4. Oscillogram Measurements and Calculations

The signal traces on the oscillogram were converted into the corresponding voltages by performing a calibration experiment in which a known constant voltage (measured potentiometrically) was applied to the oscilloscope and the ratio of this voltage to the deflection in the oscilloscope was determined. Because of oscilloscope imperfections, this ratio, or "calibration factor," is a function of three semi-independent parameters: The horizontal position of the trace on the oscillogram, its vertical level, and the magnitude of the deflection.

Ideally, for every point measured, the known applied voltage should be chosen to produce a deflection equal to that accompanying the

unknown pulse signal and at the same horizontal and vertical positions. Rapidly changing pulses would then require one calibration for each point of measurement, or a study of the variation of deflection with the three parameters would be needed for each oscilloscope used. However, it is possible to avoid an excessive number of calibrations by making two calibration measurements for each pair of pulses, one equal in deflection to that of the extreme left end of the pulse range to be measured (usually a positive deflection at the start), and a corresponding one for the extreme right end (usually a negative deflection at the finish in a trapezoidal pulse). The calibration factor k_x for any intermediate point x is then interpolated as follows:

$$k_x = k_1 + (k_n - k_1) (t_x - t_1) / (t_n - t_1) \quad (1)$$

where k_1 and k_n are, respectively, the initial and final calibration factors and t_x , t_1 , t_n are the corresponding times.

This technique assumes that the calibration factor has a linear variation with each of the two position parameters. It automatically corrects for the effect of these two parameters regardless of drift in the calibration from day to day or with a change in oscilloscope. The correction for pulse deflection magnitude was found to be negligible in comparison with those for position. The errors due to interpolation and neglect of the deflection magnitude parameter were minimized by the fact that pulse experiments were designed to intersect the baseline approximately at the midpoint of the trace. Thus, the calibration factor was accurately measured at the extreme positions where the contribution of oscilloscope error to the total signal is greatest, and interpolated at intermediate points where the contribution of the more accurate potentiometric measurement was more important.

The deflections themselves in the pulse and calibration oscillograms were measured by reading the difference between the center of the pulse trace and the center of a baseline which represented the position of the beam when only the suppression voltage was present. The pulse trace (figure 6) shows initial and final traces at the baseline level and an intermediate trace at the pulse level. Because the absent portion of the base level may not be linear, a separate baseline trace, superimposed on the pulse trace 2, was taken before the pulse, and a baseline level was thus obtained for each pulse position measured. A correction had to be made, however, for an imperfection which occurred in superposition of the base level of the pulse trace and the level of the baseline. This correction was obtained by algebraically adding the pulse-baseline difference at the ends to that measured at the intermediate points. The overlap was different at the two ends of the pulse and therefore had to be interpolated between them as for the calibration factor. The total pulse deflection, Δ , at a given time, t_x , was obtained as follows:

$$\Delta = B_x - A_x + 2[D_1 - C_1 + (D_n - C_n + C_1 - D_1) (t_x - t_1)/(t_n - t_1)] \quad (2)$$

where

$B_x - A_x$ is the uncorrected pulse deflection at point x, A representing the pulse trace center and B the corresponding baseline center,

C_1 is the level of the baseline just after it diverges from the overlap,

D_1 is the level of the overlapping pulse and baselines just before divergence,

Subscript n refers to the corresponding points after the end of the pulse, C_n before convergence, D_n after convergence,

t_1, t_n, t_x are the corresponding times.

These points are shown on figure 6.

5. Results and Discussion

The method was assessed by comparing the resistance of an Inconel tube measured as described in Section 3 under steady-state and under pulse conditions at 25°C. The following measurements were made:

1. A steady-state potentiometric measurement of the resistance of the Inconel tube before the series of pulse measurements and, three months later, after the series. The mean of six measurements (at 25°C) in each case was 3.07755 mΩ before and 3.07778 mΩ after. The average of the two means, 3.07767 mΩ was used as a standard for the pulse measurements.
2. A group of 14 rectangular 100 ms pulses of about 600 A, in which an average of 12.6 percent of the pulse amplitude was recorded on the oscilloscope, the remainder measured before and after the pulse by potentiometer. Five measurements on the current and voltage oscilloscope traces were made at equally spaced time intervals for a total of 70 measurements.
3. A group of three rectangular pulses similar to the last, but with an average of 0.5 percent of the pulse amplitude recorded.
4. A group of eight trapezoidal 90 ms pulses of about 500 A, in which an average of 6 percent of the pulse was recorded at the start, 1.5 percent at the midpoint, and -6 percent at the end, that is, the suppression voltage measured potentiometrically was greater than the amplitude of the last half of the pulse resulting in a negative deflection on the oscilloscope. These pulses are representative of the pulse shape to be expected in a high-speed thermodynamic experiment in which the specimen

temperature is changing rapidly over a range of several hundred or thousand degrees. For each pulse, a total of five measurements at equally spaced time intervals were made.

5. A group of 11 trapezoidal 50 ms pulses of about 1300 A, in which an average of 4 percent of the pulse was recorded at the start, 0.2 percent at the midpoint, and -4 percent at the end.

Table 1 lists the difference between steady-state and pulse resistance values and the standard deviation of each group of measurements described in items 2 to 5. Figure 7 shows the dependence of the above on the fraction recorded on the oscilloscope for both rectangular and trapezoidal pulses. In general, if the fraction recorded was kept as low as 6 percent of the total, an accuracy of 0.1 percent or better and a reproducibility of ± 0.07 percent or better were possible, and for fractions of 1 percent or less, errors of the order of 0.01 percent in resistance could be achieved.

The average systematic error of all the determinations reported in this paper was positive. This positive systematic error decreased almost to zero as the fraction recorded approached zero, whereas the resistance corresponding to the negative limit of the standard deviation remained almost constant. There was apparently a bias of unknown origin in the oscilloscope recordings.

The possibility of decreasing the number of calibration measurements is indicated by the fact that calibration factors at a given oscilloscope position were reproducible from one experiment to another on a given day to about 1 percent. The results reported in these experiments were obtained with one calibration between each two pulses.

The quasi-pulse experiments described in Section 3 (with steady-state current of approximately 12 A and effective measurement duration of 50 ms) produced the following results: for 20 measurements at each suppression level recorded, the voltage oscilloscope showed a mean systematic error of -0.027 percent at 90 percent suppression and -0.003 percent at 98.9 percent suppression; the current oscilloscope +0.024 percent at 92 percent suppression and -0.004 percent at 99.2 percent suppression. At the higher fractions recorded, the systematic errors for voltage and current were each about one-third the systematic error of a resistance measurement and were opposite in sign. This limited group of data would favor the idea that the power measurements would be no less accurate than the resistance measurements.

There are several sources of error that contributed to the measured difference between steady-state and pulse resistance values. Steady-state resistance measurements were one or two orders of magnitude more accurate than pulse measurements. Therefore, most of the difference can be attributed to errors in pulse measurements. A list of major sources of error and their estimated magnitudes in oscilloscopic recording of a quantity in pulse experiments is given in

Table 2. It may be noted that the table includes also errors due to phenomena affecting the components of the overall system in addition to the suppression unit-oscilloscope combination.

6. Conclusions

The results of the present investigation have shown that it is possible to measure quantities in high-speed experiments with an inaccuracy of 0.1 to 0.01 percent using an improved oscilloscopic technique. This method is applicable primarily to experiments in which the pulse shape is rectangular or flat trapezoidal.

The method was checked by conducting pulse experiments of millisecond resolution, in which the resistance of an Inconel tube measured under pulse conditions was compared with its direct-current value. An increase of one or two orders of magnitude in the measurement accuracy was achieved by (1) suppressing the major portion of the signals by known constant voltages, and (2) providing time synchronization between traces on different oscilloscope screens. It was observed that the increase in accuracy was approximately proportional to the suppression level.

Although high-speed digital data acquisition systems show great promise especially in millisecond resolution experiments [1, 2] their use, at present, is limited because of electronic complexities and relatively high prices. Thus, the improved oscilloscopic recording system may have immediate applications in various high-speed (millisecond resolution) measurements of thermodynamic, transport, and other related properties at high temperatures. The basic concept of this method, after some modifications, may also be applied to other experiments of even higher time resolution (microsecond), such as exploding conductor, gaseous discharge, shock, etc.

The authors wish to extend their appreciation to Dr. C. W. Beckett for his encouragement of research in high-speed measurement techniques.

7. References

- [1] Cezairliyan, A., M. S. Morse, H. A. Berman, and C. W. Beckett, J. Res. Nat. Bur. Stand. (U. S.), 74A (Phys. and Chem.), 65 (1970).
- [2] Kollie, T. G., M. Barrisoni, D. L. McElroy, and C. R. Brooks, High Temp. - High Pres., 1, 167 (1969).

Table I. Results of High-Speed Resistance Measurements

Pulse Shape	Fraction Recorded on Oscilloscope, (Percent)	Number of Measurements	Resistance Difference (Percent)	Standard Deviation (Percent)
Rectangular, 600 A	12.6	70	+0.08	0.09
Rectangular, 600 A	0.5	15	+0.003	0.01
Trapezoidal, 500 A	6	16	+0.08	0.06
Trapezoidal, 500 A	3	16	+0.03	0.04
Trapezoidal, 500 A	1.5	8	+0.009	0.02
Trapezoidal, 1300 A	4	22	+0.07	0.06
Trapezoidal, 1300 A	2	22	+0.04	0.03
Trapezoidal, 1300 A	0.2	11	+0.005	0.03

Table 2. List of Major Sources of Error in Oscilloscopic Recording of a Quantity Using Suppression

Source of Error	Error (percent)		
	On Overall Signal	On Recorded Portion	On Suppressed Portion
Skin effect	< 0.01		
Self-inductance*	0.0002-0.02		
Mutual-inductance	< 0.01		
Temperature variations	< 0.01		
Frequency response**	< 0.01		
Time synchronization		0.05	
Oscillogram reading		0.1	
Calibration		1	
Suppression voltage			0.001
Potentiometer, etc.***			0.005

*The exact value depends upon the nature of the pulse and the geometry of the resistance across which potential measurements are made.

**The frequency response of the suppression units was checked for frequencies up to 10 kHz.

***The potentiometer error does not enter into a comparison of pulse and steady-state resistances, voltages, or currents, but does affect power measurements in a thermodynamic experiment.

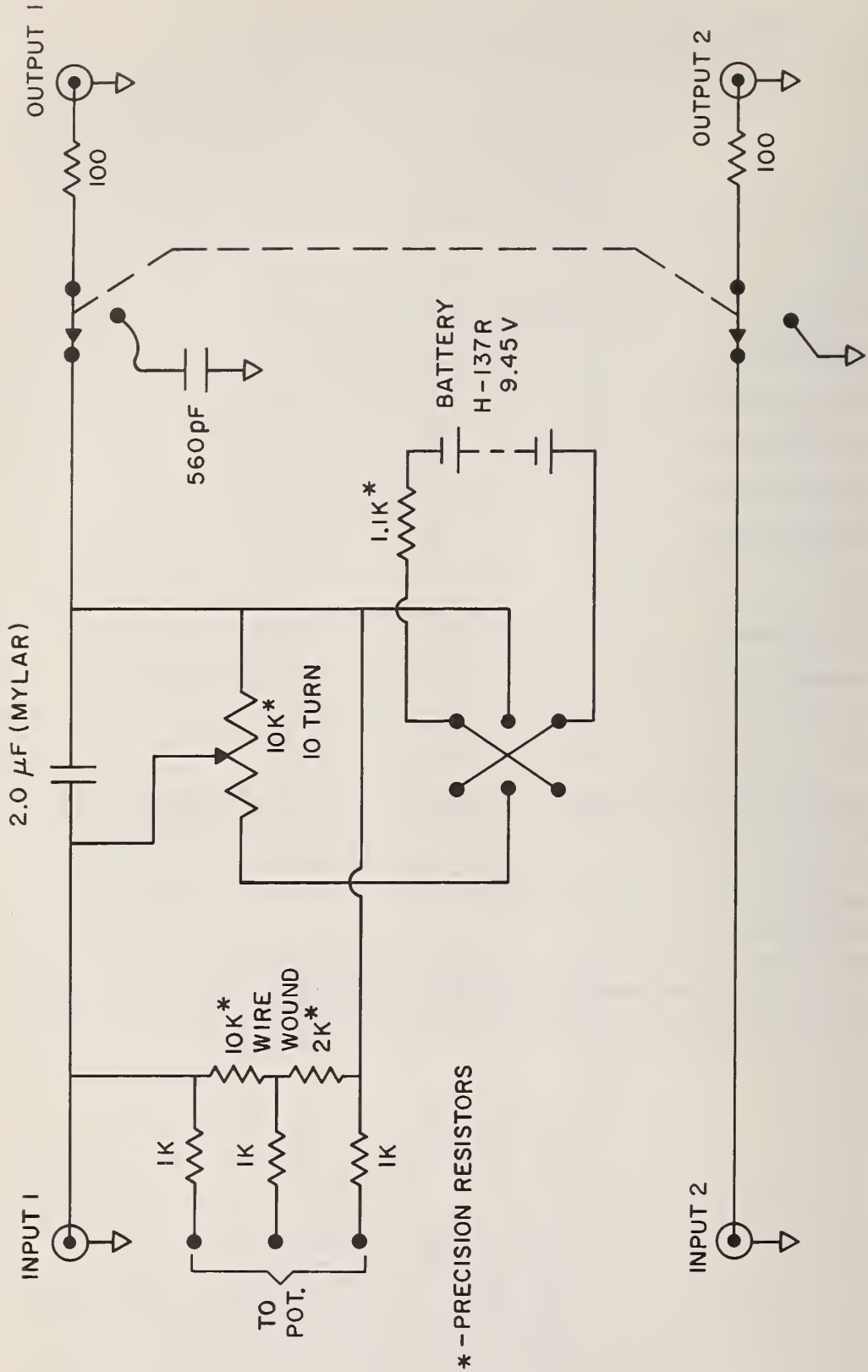

* - PRECISION RESISTORS

Figure 1. Circuit diagram of differential suppression unit.

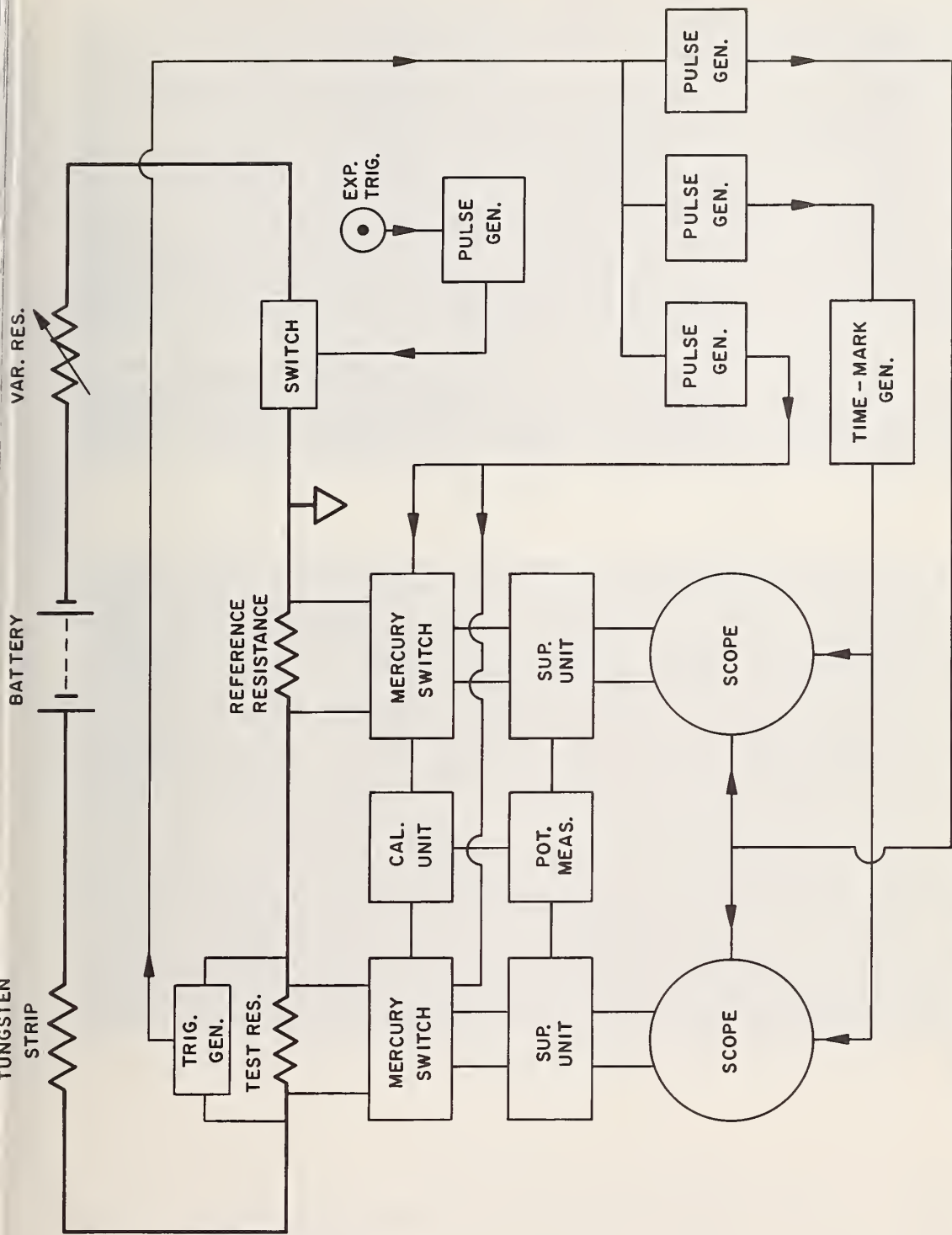
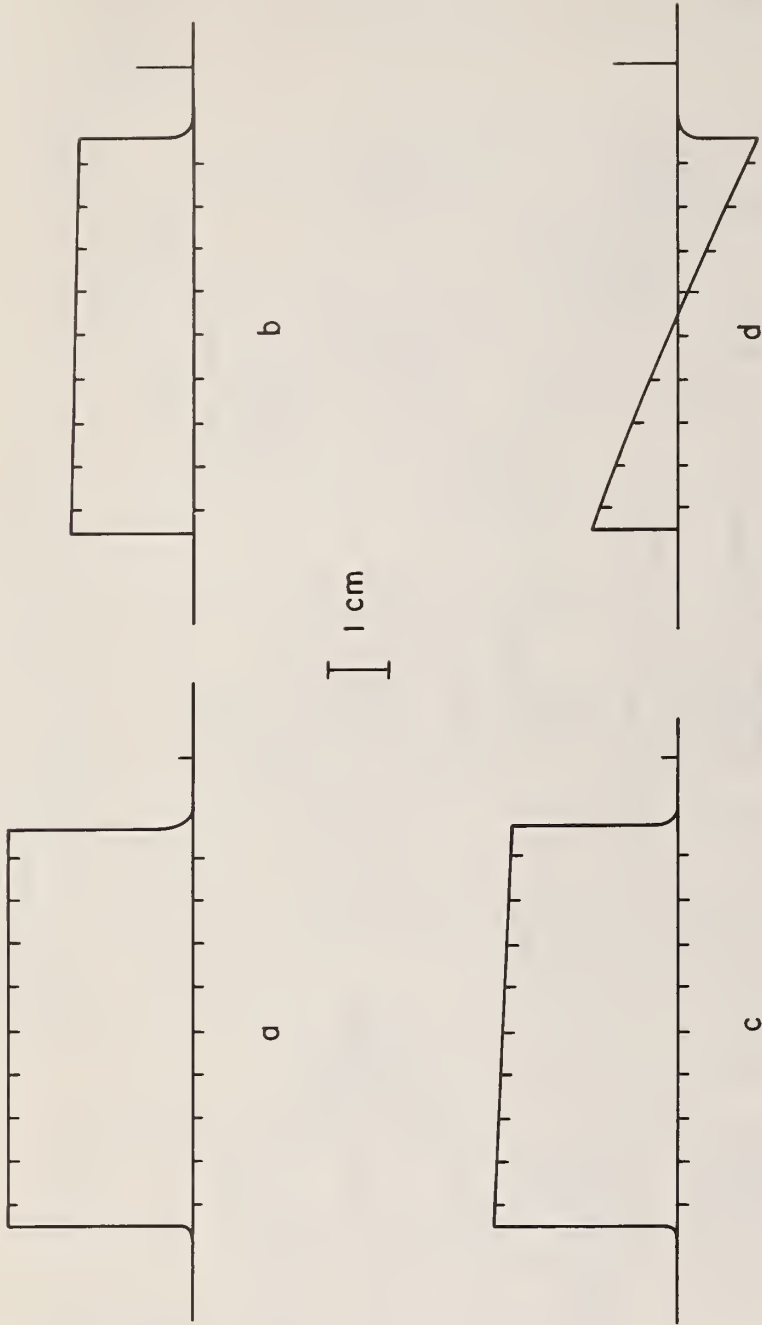

Figure 2. Functional diagram of the improved oscilloscopic recording system including the testing circuitry.



SCALE (mV cm⁻¹)

- a RECTANGULAR PULSE - FULL RECORDING 500
- b RECTANGULAR PULSE - AFTER SUPPRESSION (90%) 50
- c TRAPEZOIDAL PULSE - FULL RECORDING 500
- d TRAPEZOIDAL PULSE - AFTER SUPPRESSION 50

INTERVAL BETWEEN TIME MARKERS = 5 ms

Figure 3. Oscilloscope reproductions of typical rectangular and trapezoidal pulses.

VOLTAGE

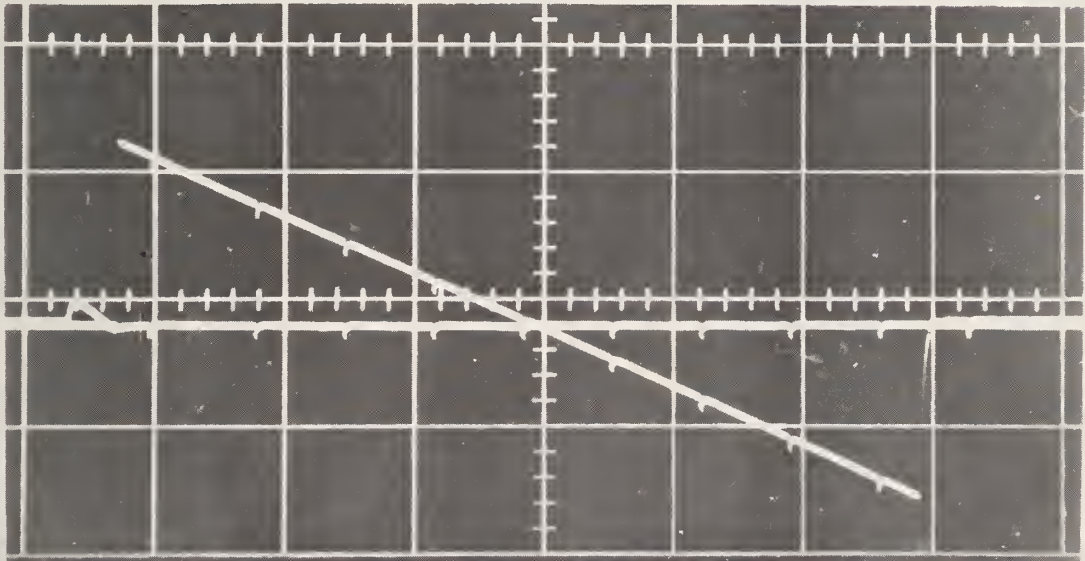
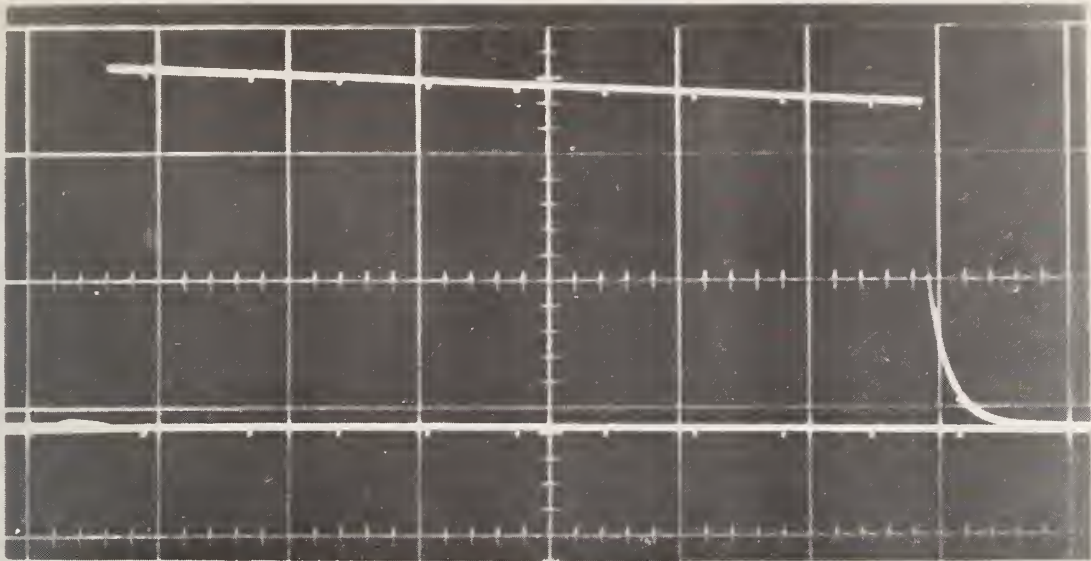

TIME

Figure 4. Actual oscillograms of a trapezoidal pulse with and without suppression.

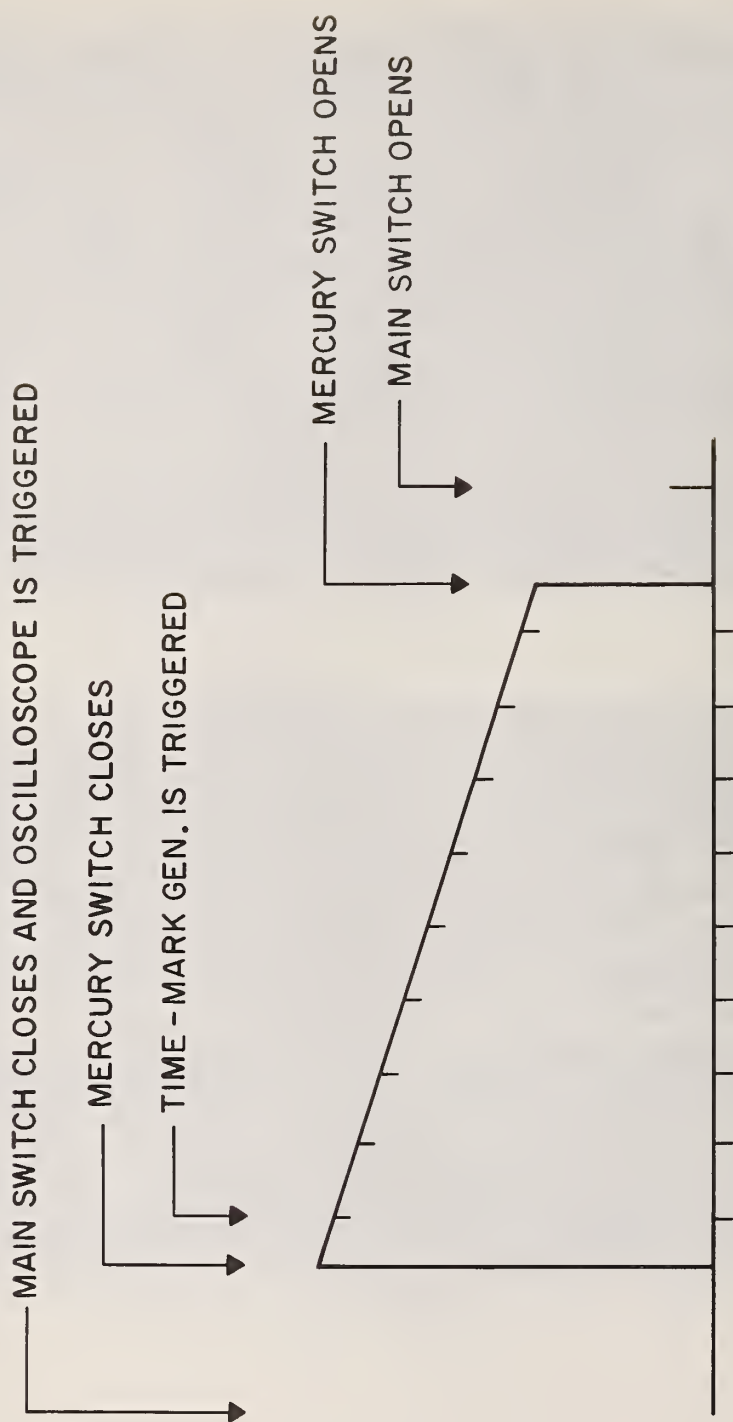

Figure 5. Time sequence of major events in improved oscilloscopic recording.

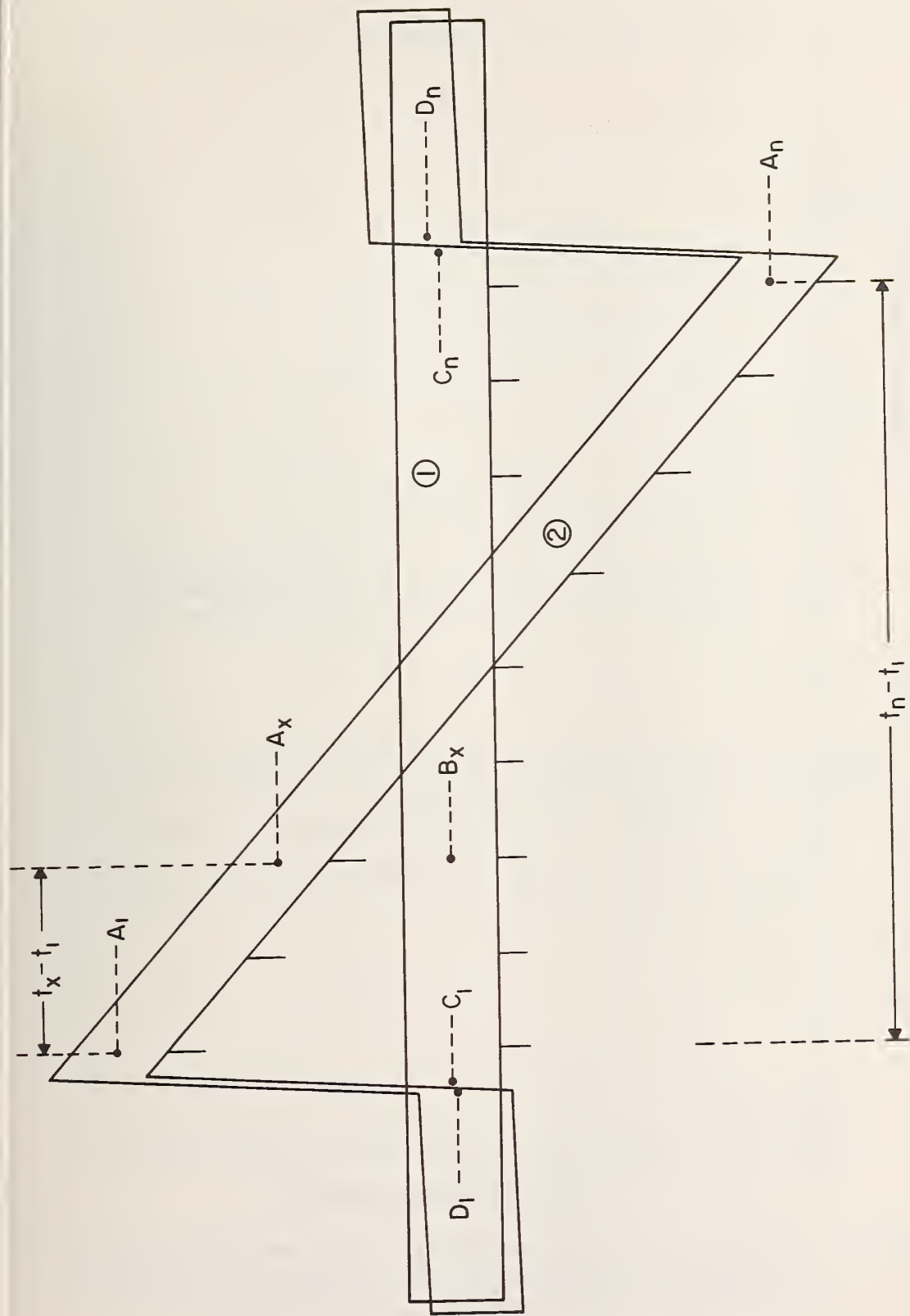

Figure 6. Schematic drawing of a trapezoidal pulse and its baseline (line thickness and end imperfections are exaggerated).

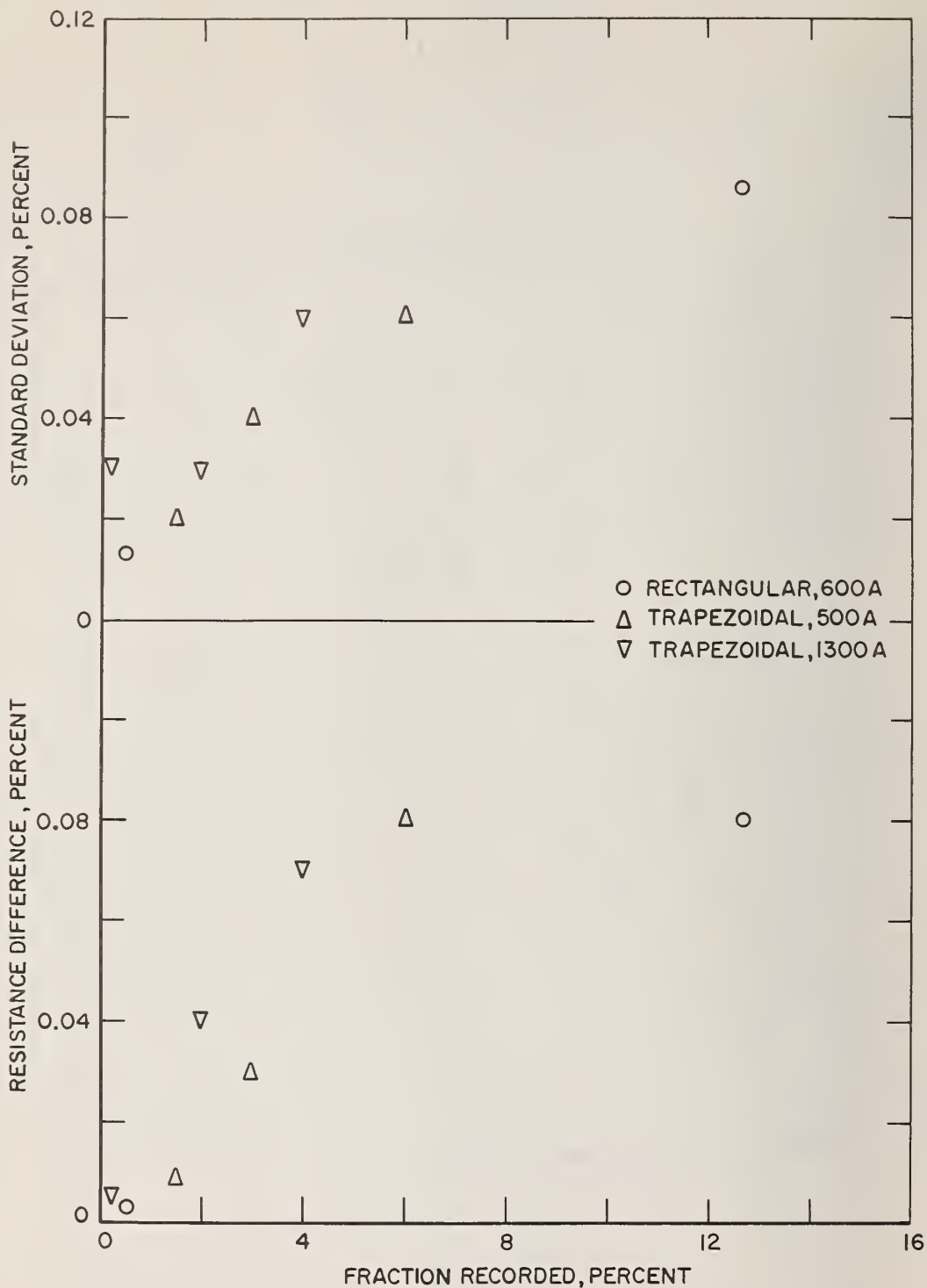

Figure 7. Variation of resistance difference and standard deviation of an individual determination of resistance as a function of percentage of signal recorded on oscilloscope.

Latest developments in the subject area of this publication, as well as in other areas where the National Bureau of Standards is active, are reported in the NBS Technical News Bulletin. See following page.

HOW TO KEEP ABREAST OF NBS ACTIVITIES

Your purchase of this publication indicates an interest in the research, development, technology, or service activities of the National Bureau of Standards.

The best source of current awareness in your specific area, as well as in other NBS programs of possible interest, is the TECHNICAL NEWS BULLETIN, a monthly magazine designed for engineers, chemists, physicists, research and product development managers, librarians, and company executives.

If you do not now receive the TECHNICAL NEWS BULLETIN and would like to subscribe, and/or to review some recent issues, please fill out and return the form below.

Mail to: Office of Technical Information and Publications
National Bureau of Standards
Washington, D. C. 20234

Name _____

Affiliation _____

Address _____

City _____ State _____ Zip _____

Please send complimentary past issues of the Technical News Bulletin.

Please enter my 1-yr subscription. Enclosed is my check or money order for \$3.00 (additional \$1.00 for foreign mailing).

Check is made payable to: SUPERINTENDENT OF DOCUMENTS.

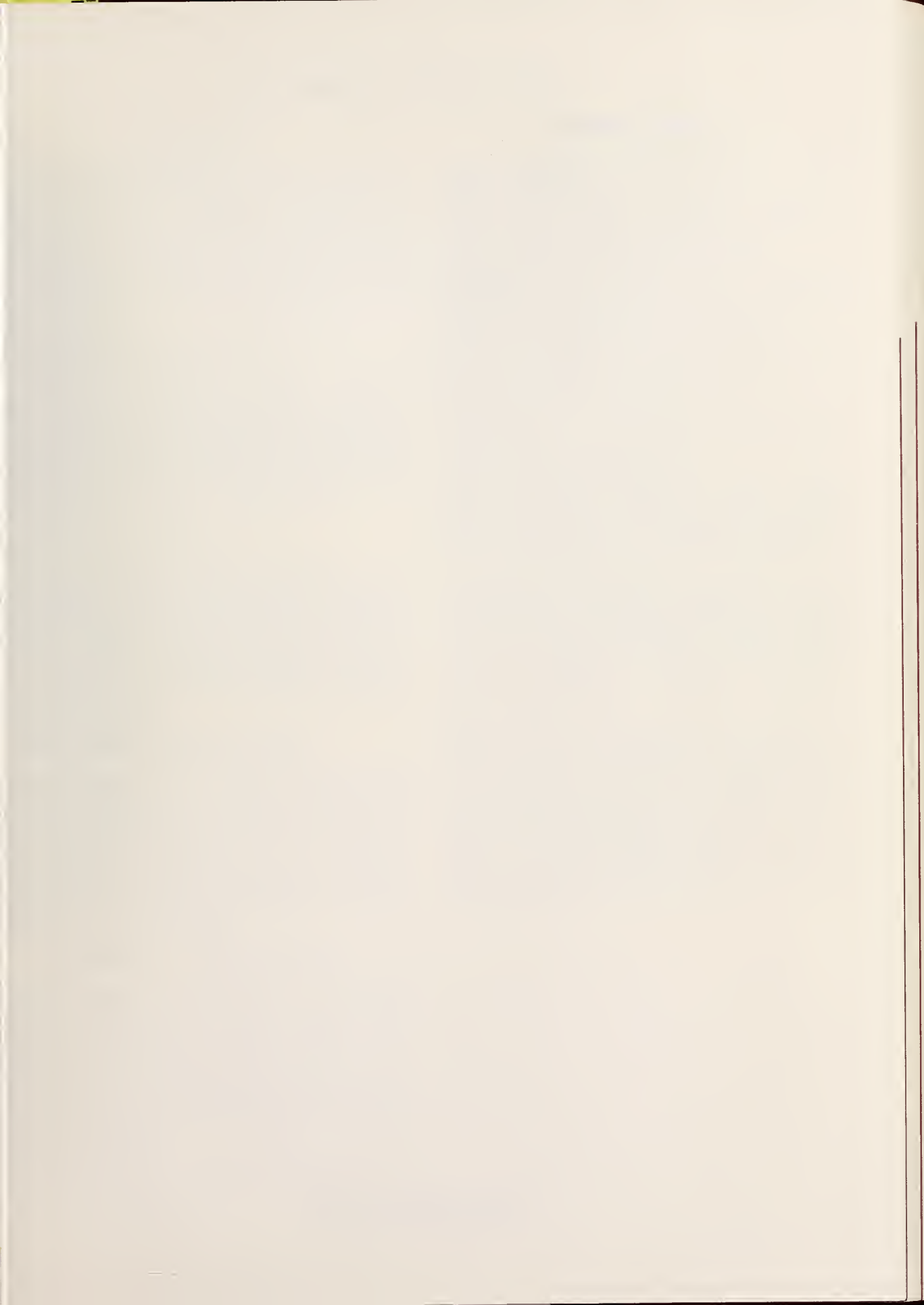



NBS TECHNICAL PUBLICATIONS

PERIODICALS

NONPERIODICALS

JOURNAL OF RESEARCH reports National Bureau of Standards research and development in physics, mathematics, chemistry, and engineering. Comprehensive scientific papers give complete details of the work, including laboratory data, experimental procedures, and theoretical and mathematical analyses. Illustrated with photographs, drawings, and charts.

Published in three sections, available separately:

● Physics and Chemistry

Papers of interest primarily to scientists working in these fields. This section covers a broad range of physical and chemical research, with major emphasis on standards of physical measurement, fundamental constants, and properties of matter. Issued six times a year. Annual subscription: Domestic, \$9.50; foreign, \$11.75*.

● Mathematical Sciences

Studies and compilations designed mainly for the mathematician and theoretical physicist. Topics in mathematical statistics, theory of experiment design, numerical analysis, theoretical physics and chemistry, logical design and programming of computers and computer systems. Short numerical tables. Issued quarterly. Annual subscription: Domestic, \$5.00; foreign, \$6.25*.

● Engineering and Instrumentation

Reporting results of interest chiefly to the engineer and the applied scientist. This section includes many of the new developments in instrumentation resulting from the Bureau's work in physical measurement, data processing, and development of test methods. It will also cover some of the work in acoustics, applied mechanics, building research, and cryogenic engineering. Issued quarterly. Annual subscription: Domestic, \$5.00; foreign, \$6.25*.

TECHNICAL NEWS BULLETIN

The best single source of information concerning the Bureau's research, developmental, cooperative and publication activities, this monthly publication is designed for the industry-oriented individual whose daily work involves intimate contact with science and technology—for *engineers, chemists, physicists, research managers, product-development managers, and company executives*. Annual subscription: Domestic, \$3.00; foreign, \$4.00*.

* Difference in price is due to extra cost of foreign mailing.

Applied Mathematics Series. Mathematical tables, manuals, and studies.

Building Science Series. Research results, test methods, and performance criteria of building materials, components, systems, and structures.

Handbooks. Recommended codes of engineering and industrial practice (including safety codes) developed in cooperation with interested industries, professional organizations, and regulatory bodies.

Special Publications. Proceedings of NBS conferences, bibliographies, annual reports, wall charts, pamphlets, etc.

Monographs. Major contributions to the technical literature on various subjects related to the Bureau's scientific and technical activities.

National Standard Reference Data Series. NSRDS provides quantitative data on the physical and chemical properties of materials, compiled from the world's literature and critically evaluated.

Product Standards. Provide requirements for sizes, types, quality and methods for testing various industrial products. These standards are developed cooperatively with interested Government and industry groups and provide the basis for common understanding of product characteristics for both buyers and sellers. Their use is voluntary.

Technical Notes. This series consists of communications and reports (covering both other agency and NBS-sponsored work) of limited or transitory interest.

Federal Information Processing Standards Publications. This series is the official publication within the Federal Government for information on standards adopted and promulgated under the Public Law 89-306, and Bureau of the Budget Circular A-86 entitled, Standardization of Data Elements and Codes in Data Systems.

Order NBS publications from:

Superintendent of Documents
Government Printing Office
Washington, D.C. 20402

U.S. DEPARTMENT OF COMMERCE
WASHINGTON, D.C. 20230

OFFICIAL BUSINESS

PENALTY FOR PRIVATE USE, \$300



POSTAGE AND FEES PAID
U.S. DEPARTMENT OF COMMERCE