



**NBS**

**TECHNICAL NOTE**

National Bureau of Standards  
Library, E-01  
APR 21 1969

370

**Calibration Principles and Procedures  
For Field Strength Meters (30 Hz to 1 GHz)**

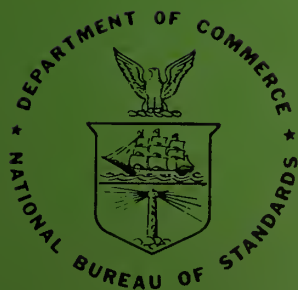

---

**U.S. DEPARTMENT OF COMMERCE  
National Bureau of Standards**

## NATIONAL BUREAU OF STANDARDS

The National Bureau of Standards<sup>1</sup> was established by an act of Congress March 3, 1901. Today, in addition to serving as the Nation's central measurement laboratory, the Bureau is a principal focal point in the Federal Government for assuring maximum application of the physical and engineering sciences to the advancement of technology in industry and commerce. To this end the Bureau conducts research and provides central national services in three broad program areas and provides central national services in a fourth. These are: (1) basic measurements and standards, (2) materials measurements and standards, (3) technological measurements and standards, and (4) transfer of technology.

The Bureau comprises the Institute for Basic Standards, the Institute for Materials Research, the Institute for Applied Technology, and the Center for Radiation Research.

**THE INSTITUTE FOR BASIC STANDARDS** provides the central basis within the United States of a complete and consistent system of physical measurement, coordinates that system with the measurement systems of other nations, and furnishes essential services leading to accurate and uniform physical measurements throughout the Nation's scientific community, industry, and commerce. The Institute consists of an Office of Standard Reference Data and a group of divisions organized by the following areas of science and engineering:

Applied Mathematics—Electricity—Metrology—Mechanics—Heat—Atomic Physics—Cryogenics<sup>2</sup>—Radio Physics<sup>2</sup>—Radio Engineering<sup>2</sup>—Astrophysics<sup>2</sup>—Time and Frequency.<sup>2</sup>

**THE INSTITUTE FOR MATERIALS RESEARCH** conducts materials research leading to methods, standards of measurement, and data needed by industry, commerce, educational institutions, and government. The Institute also provides advisory and research services to other government agencies. The Institute consists of an Office of Standard Reference Materials and a group of divisions organized by the following areas of materials research:

Analytical Chemistry—Polymers—Metallurgy—Inorganic Materials—Physical Chemistry.

**THE INSTITUTE FOR APPLIED TECHNOLOGY** provides for the creation of appropriate opportunities for the use and application of technology within the Federal Government and within the civilian sector of American industry. The primary functions of the Institute may be broadly classified as programs relating to technological measurements and standards and techniques for the transfer of technology. The Institute consists of a Clearinghouse for Scientific and Technical Information,<sup>3</sup> a Center for Computer Sciences and Technology, and a group of technical divisions and offices organized by the following fields of technology:

Building Research—Electronic Instrumentation—Technical Analysis—Product Evaluation—Invention and Innovation—Weights and Measures—Engineering Standards—Vehicle Systems Research.

**THE CENTER FOR RADIATION RESEARCH** engages in research, measurement, and application of radiation to the solution of Bureau mission problems and the problems of other agencies and institutions. The Center for Radiation Research consists of the following divisions:

Reactor Radiation—Linac Radiation—Applied Radiation—Nuclear Radiation.

<sup>1</sup> Headquarters and Laboratories at Gaithersburg, Maryland, unless otherwise noted; mailing address Washington, D. C. 20234.

<sup>2</sup> Located at Boulder, Colorado 80302.

<sup>3</sup> Located at 5285 Port Royal Road, Springfield, Virginia 22151.

UNITED STATES DEPARTMENT OF COMMERCE  
NATIONAL BUREAU OF STANDARDS • A. V. Astin, Director



# TECHNICAL NOTE 370

ISSUED MARCH 1969

## **Calibration Principles and Procedures for Field Strength Meters 30 (Hz to 1 GHz)**

Harold E. Taggart  
and  
John L. Workman

Radio Standards Engineering Division  
Institute for Basic Standards  
National Bureau of Standards  
Boulder, Colorado 80302

NBS Technical Notes are designed to supplement the Bureau's regular publications program. They provide a means for making available scientific data that are of transient or limited interest. Technical Notes may be listed or referred to in the open literature.

## FOREWORD

This report was written to help those people engaged in the calibration of field strength meters at frequencies from 30 Hz to 1 GHz. The methods and procedures outlined in this report were developed and have been evaluated at the National Bureau of Standards. The step-by-step procedures were written and illustrated so that technical personnel can easily duplicate the equipment setups and perform the calibrations.

A commercial field strength meter requiring all phases of calibration was selected for writing the step-by-step calibration procedures. The selection of the meter does not indicate endorsement or disapproval of the product by the National Bureau of Standards.

The recommended equipment used in the calibration systems are types whose specification meet the requirements of the calibration systems. Other types whose specifications are equivalent or better than those listed can be used.

The writing of this report was sponsored by the Department of the Air Force, Rome Air Development Center, Griffiss Air Force Base, New York, under Contract No. AF30(602)-4383.

# TABLE OF CONTENTS

ABSTRACT	- - - - -	vi
1.0	INTRODUCTION - - - - -	1
1.1	The Basic Field Strength Meter - - - - -	1
1.2	Calibration of the Receiver - - - - -	4
1.3	Calibration of the Antenna - - - - -	5
1.4	Components of the Standard Antenna Set - - -	6
2.0	TWO-TERMINAL RF VOLTMETER CALIBRATION -	10
2.1	General Description and Characteristics of RF Micropotentiometers - - - - -	10
2.2	Calibrated Signal Generator - - - - -	21
2.3	Two-Terminal RF Voltmeter Calibration Uncertainties - - - - -	21
2.4	Procedure for Calibrating the NF-105 as a Two-Terminal RF Voltmeter- - - - -	22
2.4.1	DC Calibration of the Micropotentiometer -	22
2.4.2	Calibration of the NF-105 Receiver as a Two-Terminal RF Voltmeter Using the RF Micropotentiometer - - - - -	26
3.0	CALIBRATION OF FIM SIGNAL ATTENUATORS -	41
3.1	General Discussion - - - - -	41
3.2	Attenuator Ratio Measurement Uncertainties	42
3.3	Procedure for Calibrating the NF-105 Signal Attenuators - - - - -	42
4.0	CALIBRATION OF THE FIM OVERALL LINEARITY -	51
4.1	General Discussion - - - - -	51
4.2	Overall Linearity Measurement Uncertainties -	52
4.3	Procedure for Calibrating the Overall Linearity of the NF-105- - - - -	52

5.0	CALIBRATION OF LOOP ANTENNAS	- - - - -	59
5.1	General Discussion	- - - - -	59
5.2	Standard-Field Method	- - - - -	64
5.3	Standard-Antenna Method	- - - - -	68
5.4	Injection Method	- - - - -	70
5.5	Loop Antenna Measurements Uncertainties	- - - - -	75
5.6	Calibration Procedure for Loop Antennas (30 Hz - 30 MHz) Using the Standard-Field Method	-	75
5.6.1	Calibration Site	- - - - -	76
5.6.2	Basic Setup	- - - - -	76
5.6.3	Calculation of the Calibrating Field	- - - - -	79
5.6.4	Calibration Procedure Using the Standards- Field Method	- - - - -	82
5.6.5	Uncertainties	- - - - -	86
5.7	Calibration Procedure for Loop Antennas Using the Injection Method	- - - - -	86
5.7.1	Basic Setup	- - - - -	87
5.7.2	Calculation of the Injection Voltage	- - - - -	90
5.7.3	Calibration Procedure Using the Injection Method	- - - - -	92
5.7.4	Uncertainties	- - - - -	93
6.0	CALIBRATION OF DIPOLE ANTENNAS	- - - - -	95
6.1	General Discussion	- - - - -	95
6.2	Calibrating Dipole Antennas Using the Standard- Antenna Method	- - - - -	98
6.3	Other Methods of Calibrating Dipole Antennas	- - - - -	107
6.4	Dipole Antenna Measurements Uncertainties	- - - - -	108
6.5	Calibration Procedure for Dipole Antennas (30 - 1000 MHz) Using the Standard-Antenna Method	-	110
6.5.1	Calibrating Site	- - - - -	111
6.5.2	Basic Setup	- - - - -	112
6.5.3	Calibration of the Voltage Standard	- - - - -	115
6.5.4	Calibration of the Antenna Crystal Diode	- - - - -	117
6.5.5	Calibration of the Unknown Receiving Antenna	- - - - -	118
6.5.6	Uncertainties	- - - - -	119

7.0	THE CALIBRATION REPORT - - - - -	124
7.1	General Discussion - - - - -	124
7.2	Two-Terminal RF Voltmeter Calibration - - - - -	125
7.3	Signal Input Attenuator Calibration - - - - -	125
7.4	Overall Linearity Calibration - - - - -	129
7.5	Loop Antenna Calibration - - - - -	129
7.6	Dipole Antenna Calibration - - - - -	133
REFERENCES - - - - -		149
DECIBELS vs VOLTAGE and POWER - - - - -		150
D.C. CALIBRATION UNIT - - - - -		151

## ABSTRACT

The National Bureau of Standards has been calibrating many types of field strength meters and their related antennas at frequencies up to 1000 MHz for several years. Various techniques of measurement have been investigated regarding accuracy, calibration time, ease of operation, and reliability. This report discusses some of these calibration techniques in detail, and in some cases lists step-by-step procedures for performing the complete calibration. Typical calibration data are used to take the reader from the beginning of the calibration to the completed test report. All measurement setups are clearly illustrated, listing the equipment necessary to perform the calibration. Methods of calibrating two basic types of antennas are described: (1) the loop antenna at frequencies from 30 Hz to 30 MHz and (2) half-wavelength dipole antennas from 30 to 1000 MHz. Two methods of calibrating loop antennas are discussed in detail, the standard-field method and the injection method. The standard-antenna method of calibrating dipole antennas is fully described. Measurement uncertainties of various methods are discussed. This report was written to help technical personnel actively participate in antenna calibration work. Hopefully this information will help people to set up new calibration services and to improve existing calibrating facilities.

Key Words: Calibration Procedures, Field Strength Meters,  
Loop Antennas, Dipole Antennas.



# CALIBRATION PRINCIPLES AND PROCEDURES FOR FIELD STRENGTH METERS (30 Hz to 1 GHz)

by

Harold E. Taggart and John L. Workman

## 1.0 INTRODUCTION

The purpose of this report is to present a discussion of principles and procedures for calibrating field strength meters at frequencies from 30 Hz to 1000 MHz. The field strength meter has sometimes been called "field intensity" meter. The word intensity connotes power in optics and radiation; therefore, the use of field strength is favored over field intensity. However, the abbreviation "FIM" is commonly used for field strength meter and for simplicity will be used throughout this report. The FIM consists of a receiver for measuring r-f voltage and an antenna for detecting an electromagnetic field radiated from a distant source. Methods of calibrating the receiver as an r-f voltmeter will be discussed. At frequencies from 30 Hz to 1000 MHz, loop and dipole antennas are commonly used to accurately measure electric and magnetic fields. Methods of calibrating these antennas will be discussed and step-by-step procedures will be detailed.

The techniques used to calibrate field strength meters must duplicate as nearly as possible the conditions under which the instrument will be used. The determination of field strength can readily become complicated by factors such as polarization, ground effect, reflections, multipath propagation, and near-fields, just to mention a few. An awareness of these problems is necessary in order to accurately measure radiated fields and to calibrate the field strength meter.

### 1.1 The Basic Field Strength Meter.

The field strength meter is basically a calibrated receiver and an antenna of known characteristics. The calibrated receiver usually

consists of precision attenuation circuits for changing the signal level in known increments, an internal calibration standard to provide a means of setting the gain to known positions, and a readout system of some type usually calibrated in microvolts or decibels above one microvolt.

Figure 1.1 is a block diagram of this basic field strength meter. The antenna may be a loop, a rod, a dipole, a horn or other type of antenna depending on the carrier frequency and on measurement requirements.

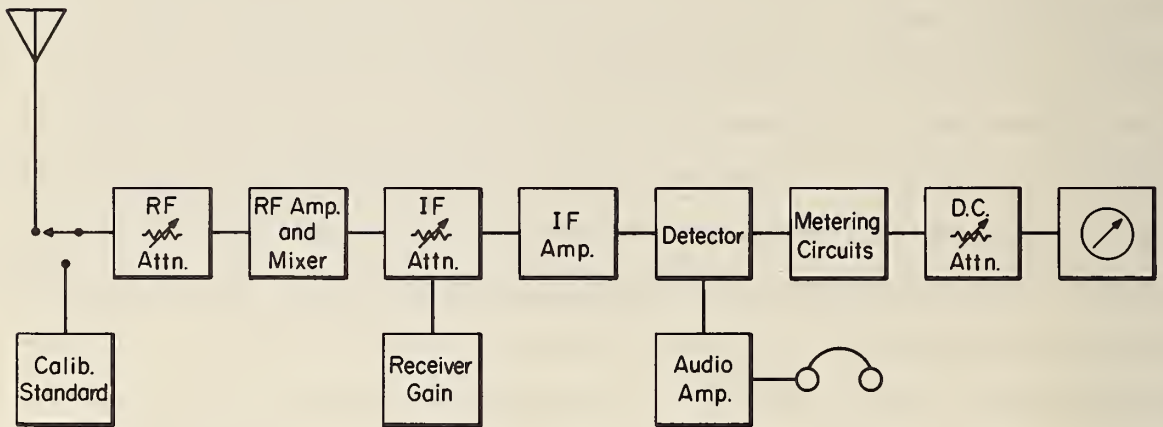

Figure 1.1. Block Diagram of a Field Strength Meter.

The signal attenuators are usually one of three types or a combination of these. The three types are (1) radio frequency (r-f) attenuators, (2) intermediate frequency (IF) attenuators, and (3) direct current (d-c) attenuators. The r-f attenuators must have good frequency response characteristics; the IF attenuators ordinarily are used at only one frequency, the intermediate frequency; therefore, their design characteristics are usually less stringent. The d-c attenuators are often located in the d-c metering circuits, hence the name. These attenuators produce the same end result which is to attenuate the measured signal in

known amounts, but each accomplishes the task in a different manner. An awareness of the type of attenuator used is often beneficial during certain measurements.

The readout system usually consists of a panel meter calibrated in microvolts or decibels above 1 microvolt. Some panel meters are single decade (0 to 20 decibels); others are double (0 to 40 decibels). The linearity of the readout system is of concern when making accurate measurements. It is not uncommon to accumulate errors of 1 to 2 decibels in overall linearity. The chief sources of error in overall linearity seem to be in the IF amplifier section and the mixer section.

The internal calibrating standard is utilized to provide a known amount of energy to the receiver so that the receiver gain can be adjusted for proper meter indication. Several types of internal calibrating standards are used. The choice is dependent somewhat on the frequency range of the meter and on the design purpose of the meter. There are three basic types commonly used: (1) impulse generators, (2) noise diodes, and (3) sine wave reference signals. The impulse generator is lightweight, can be used at a wide range of frequencies, and has an output calibrated in decibels per megahertz bandwidth (dB MHz)\*, which makes it convenient for direct substitution in broadband measurements. The noise diode generates random noise, is lightweight, and is useful over a wide frequency range. The sine wave reference signal is used in several forms, from a wide-range signal generator to a limited-range, one-level oscillator. The sine wave calibrating standard is normally larger and more complex in design; however, it is usually more stable and inherently more accurate.

\* dBMHz is a unit of measure for expressing voltage in terms of decibels above 1 microvolt per MHz of receiver bandwidth.

## 1.2 Calibration of the Receiver.

Three basic measurements are required to calibrate the receiver. They are (1) calibration of the receiver as a two-terminal r-f voltmeter, (2) calibration of the signal attenuators, and (3) calibration of the receiver's overall linearity. The two-terminal r-f voltmeter calibration can be performed with a reliable unbalanced voltage standard such as the r-f micropotentiometer. This low-impedance device will establish known voltages at levels from  $1\mu\text{V}$  to 100 mV at frequencies from d-c to 1 GHz with uncertainties from 1 to 5 percent depending on level and frequency.

The signal attenuators and the overall linearity of the receiver can be calibrated in terms of a good precision r-f attenuator. Dissipative step-type attenuators that work satisfactorily are available in this frequency range. An attenuator with a 60 decibel range in 0.1 decibel increments will calibrate most commercial field strength meters. The receiver signal attenuators are usually calibrated in increments of 20 decibels; therefore, an 80 decibel range is not required for the standard attenuator. The readout system of the receiver is calibrated in terms of the standard attenuator so that it will read correctly over the range designed. This range is usually 20 or 40 decibels. When calibrating the readout which is usually a panel meter, the corrections obtained include the non-linearities in the r-f amplifiers, the mixer, the IF amplifiers, the metering circuits, and the panel meter; therefore, the term "overall linearity" applies. Figure 1.2 is a block diagram of a system for calibrating the signal attenuators and overall linearity that can be used at frequencies from 30 Hz to 1000 MHz. The r-f substitution method of measuring attenuation is employed; therefore, the standard attenuator must be capable of performing over a wide frequency range. The termination on the standard attenuator is important if maximum accuracy is to be achieved. At the higher frequencies it is

advisable (if possible) to calibrate the standard attenuator with the output termination connected to the standard attenuator. This eliminates errors that may be encountered due to impedance variations. A calibration system such as this can perform calibrations with uncertainties of not more than 0.1 dB per 20 decibels if used carefully.

The overall errors of the FIM receiver include the uncertainties of the two-terminal voltmeter calibration, the signal attenuator calibration, and the overall linearity calibration. A 2 percent uncertainty in each calibration could amount to a maximum of 6 percent under the worst conditions.

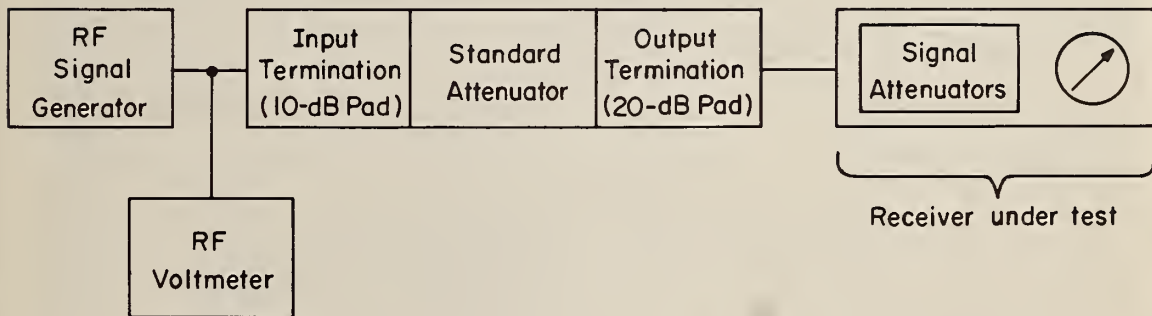

Figure 1.2. Measurement of Overall Linearity and Signal Attenuator Ratios.

### 1.3 Calibration of the Antenna.

Two methods of calibrating loop antennas are discussed in this report: (1) the standard-field method, and (2) the injection method [1]. The standard-field method is the most accurate and can be used over a wide frequency range. The injection method is not as accurate as the standard-field method, but it is much faster and can be performed in the

laboratory. The selection of the method will depend upon the accuracy requirements of the calibration.

The standard-antenna method of calibrating horizontally-polarized dipole antennas from 30 to 1000 MHz is discussed in detail in this report. Other methods are discussed only briefly. Detailed procedures of the standard-antenna method are listed herein.

#### Note.

To use the methods of calibration described above, a set of standard antennas is required. Such a set has been developed by the National Bureau of Standards for the Department of the Air Force, and it will be assumed that a comparable set of antenna standards are available.

The Standard Antenna Set is designed to calibrate loop and dipole antennas at frequencies from 30 Hz to 1000 MHz. Loop antennas can be calibrated at frequencies from 30 Hz to 30 MHz, and horizontally-polarized dipole antennas can be calibrated at frequencies from 30 to 1000 MHz. This system is designed, primarily, to calibrate field strength and interference meters and their associated antennas, although other antenna standards can also be calibrated with this system.

The d-c Calibration Unit in this system is an accurate d-c milliammeter that is used to calibrate components of the antenna system, but it can also be used as an accurate d-c supply from 1 to 1000 milliamperes for other laboratory needs. It is an excellent device for calibrating thermoelements that are frequently used in rf-dc devices such as r-f micropotentiometers or other similar instruments [2].

#### 1.4 Components of the Standard Antenna Set.

A photograph of the complete antenna set is shown in Figure 1.3. The components are placed in front of their respective packing container. Each component is numbered and named in the accompanying list.

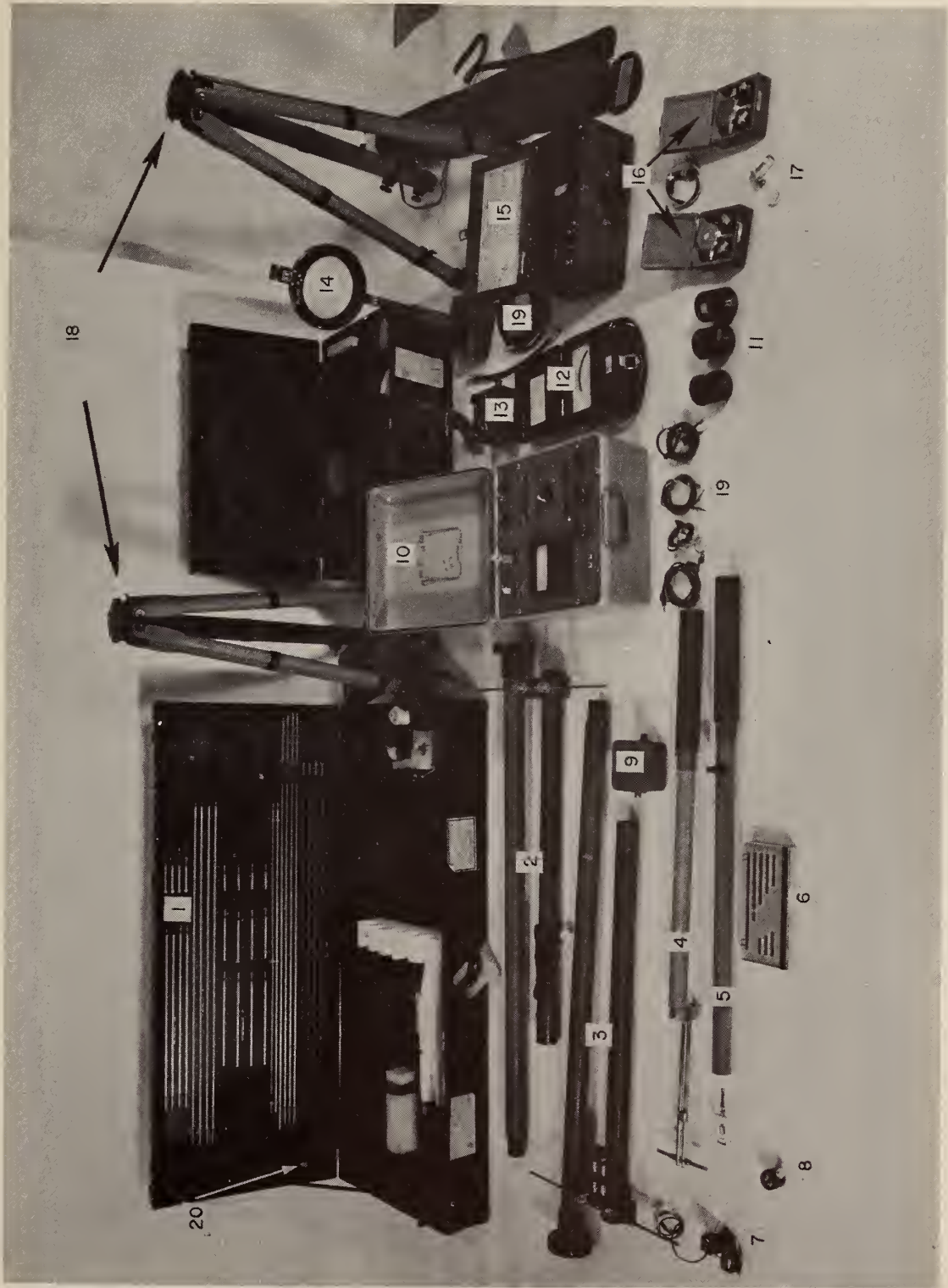

Figure 1.3. Standard Antenna Set.

## Component List

<u>Item</u>	<u>No.</u>
30 to 300 MHz Dipole Rods	1
30 to 300 MHz Transmitting Antenna	2
30 to 300 MHz Standard Receiving Antenna	3
300 to 1000 MHz Transmitting Antenna	4
300 to 1000 MHz Standard Receiving Antenna	5
300 to 1000 MHz Dipole Rods	6
30 to 300 MHz Balanced Voltage Standard	7
300 to 1000 MHz Balanced Voltage Standard	8
Balun Transformer (30 to 300 MHz)	9
D C Calibration Unit	10
Low Frequency Balun Transformers (30 Hz to 30 MHz)	11
D C Millivoltmeter	12
Loop Matching Unit	13
Standard Transmitting Loop	14
Slide Wire Potentiometer	15
RF Micropotentiometers	16
Injection Network for Loop	17
Tripod With Case	18
Miscellaneous Cables	19
Megahertz Tape	20

Figure 1.4 shows the dipole antennas packed in their carrying case.





Figure 1.4. Dipole Antennas Packed in their Carrying Case.

## 2.0 TWO-TERMINAL RF VOLTMETER CALIBRATION.

### 2.1 General Description and Characteristics of the RF Micropotentiometer.

The r-f micropotentiometer, which is a stable, accurate, and reliable working standard in the microvolt region, is a low impedance source of a known r-f voltage. This device, as shown in Figure 2.1, consists of a radial resistor in series with a thermoelement which is enclosed in a special housing. The radial resistors range from 1 milli-ohm to 1 ohm, depending on the range desired. These resistors are thin film resistors made of platinum, platinum gold, or silver, depending on the desired resistance. The thermoelement is the UHF type with a straight-through heater and the plane of the thermocouple leads is positioned  $90^\circ$  with respect to the plane of the heater.

Figure 2.2 is a schematic diagram of the r-f micropotentiometer. It can be seen from this diagram that this device is a source of voltage,  $V$ , across the resistor,  $R$ . The output voltage,  $V$ , is determined by the current and the size of the radial resistor,  $R$ , ( $V = IR$ ). This device is calibrated at d-c, and can be used to generate known r-f voltages at frequencies as high as 1000 MHz. The thermocouple output caused by the current,  $I$ , flowing through the heater of the thermoelement is an indication of this output voltage [2].

In order to cover the range from 1 microvolt to 100,000 microvolts, various combinations of resistor and thermoelement sizes must be used. Table I presents a typical set of combinations which will cover the above voltage range.

The resistance of the radial resistor is chosen below 1 ohm to minimize the error introduced by loading the output with a 50-ohm system. The size of the thermoelements do not exceed 100 milliamperes in order that the input power requirements may be minimized. Also, the larger thermoelements have an appreciable error due to skin effect at the higher frequencies. These reasons govern the selection of values that appear in this table.

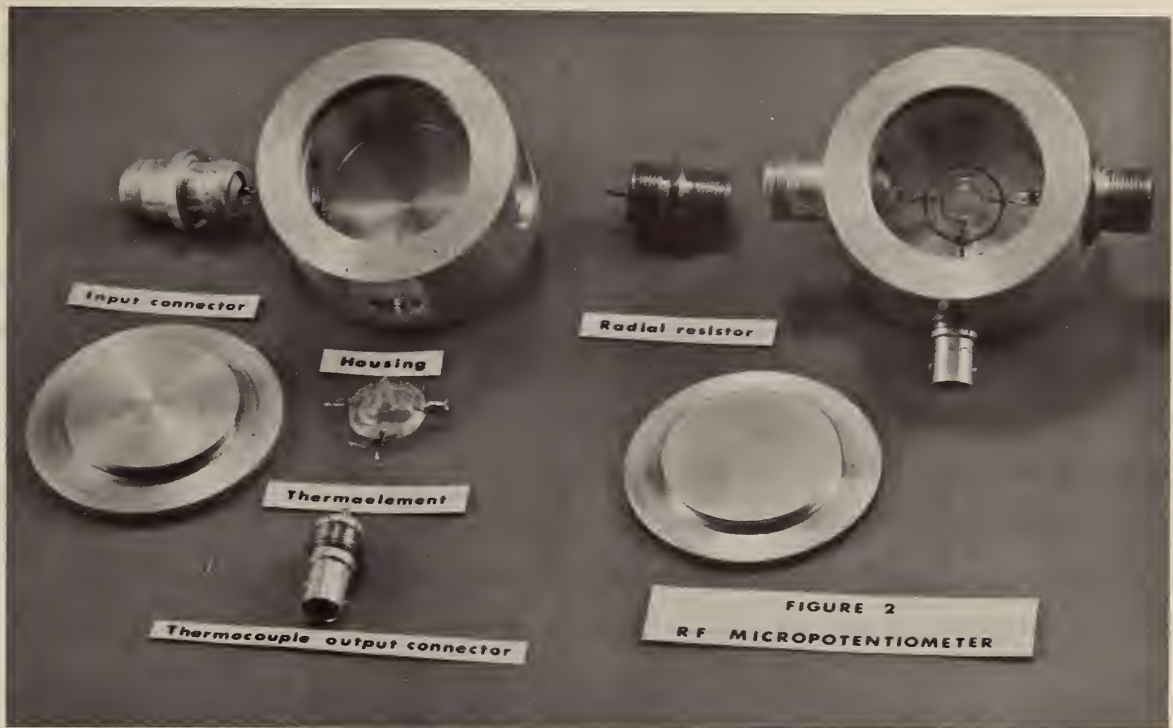

Figure 2.1. RF Micropotentiometer.

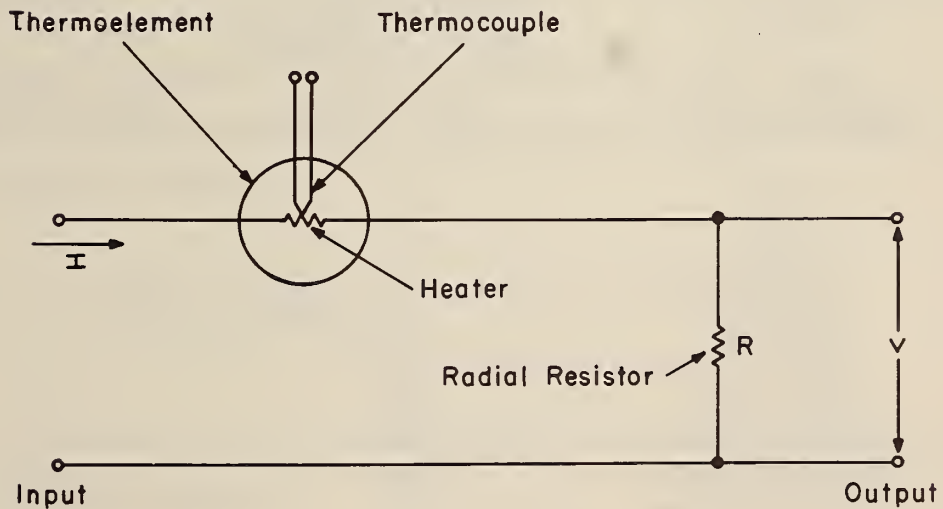

Figure 2.2. Schematic Diagram of RF Micropotentiometer.

The determining factor in the selection of micropotentiometer elements is the required output voltage. The voltage often required to calibrate a field strength receiver as a two-terminal r-f voltmeter is 100 microvolts. Table I shows that a combination of a 27 milliohm resistor and a 5 miliamp thermoelement can be used to obtain a voltage of 100 microvolts. This exact combination may not be available and another combination selected. The value of the radial resistors listed in Table I are merely nominal values that may be used to give the desired voltage. Other values can be used. It is the magnitude of the current through the resistor and the impedance of the resistor that determines the magnitude of the voltage. To assist in this selection, several guidelines and examples will be given.

TABLE I: COMBINATIONS OF RF MICROPOTENTIOMETER ELEMENTS TO COVER 1-100,000 MICROVOLTS

NOMINAL VOLTAGE RANGE	SUGGESTED RESISTANCE OF RADIAL RESISTOR	THERMOELEMENT SIZE
MICROVOLTS	MILLIOHMS	MILLIAMPERES
1-5	1	5
5-15	3	5
15-45	9	5
45-135	27	5
135-400	81	5
400-1,200	240	5
1,200-3,600	360	10
3,600-11,000	440	25
11,000-33,000	660	50
33,000-100,000	1,000	100

Normally a low-valued resistor should be selected. This reduces errors due to the loading effect on the resistor by the 50-ohm system. Resistors greater than 1 ohm are not usually recommended when calibrating 50-ohm receiver systems such as the NF-105.

A thermoelement should be selected which has a current rating equal to or higher than the computed current. It is best if the current rating of the thermoelement and the computed current are nearly equal. This gives a greater output from the thermoelement and better resolution.

The direct current required to produce the desired output voltage may be computed using Ohm's Law as follows:

$$I_{d-c} = \frac{V}{R} \quad (1)$$

where  $I_{d-c}$  = the required direct current in amperes,  
 $V$  = the desired output voltage in volts, and,  
 $R$  = the resistance of the radial resistor in ohms.

Example:

Desired output voltage,  $V = 100$  microvolts ( $100 \times 10^{-6}$  volts).

Resistance of radial resistor,  $R = 10.58$  milliohms ( $10.58 \times 10^{-3}$  ohms).

Required direct current,  $I_{d-c} = ?$ .

$$I_{d-c} = \frac{V}{R} = \frac{100 \times 10^{-6} \text{ volts}}{10.58 \times 10^{-3} \text{ ohms}} = 9.452 \times 10^{-3} \text{ amperes} \\ 9.452 \text{ milliamperes.}$$

The direct current is 9.452 milliamperes; therefore, a 10-milliampere thermoelement is required.

Thus far a method of selecting the r-f micropotentiometer has been described. Unfortunately the impedance of the radial resistor (called resistance at d-c) is not constant with frequency. This change in impedance is usually gradual with frequency. At the lower frequencies (from d-c to approximately 300 MHz) the change may be only 1 to 2 percent; at the higher frequencies (300 to 1000 MHz) it may be as high as 10 to 20 percent. The r-f micropotentiometer current is measured using direct current and any change in the impedance of the radial resistors will in turn cause an error in the output voltage. This difference in the d-c calculated output voltage and the actual r-f output voltage is called the RF-DC difference, and is normally expressed in percent on calibration reports. A sample NBS Report of Calibration is shown on pages 15 and 16.

The RF-DC difference (RF-DC correction factor) should be used to attain maximum accuracy. It can sometimes be ignored at the lower frequencies (when it is less than 1 or 2 percent) and used only at the higher frequencies.

U. S. DEPARTMENT OF COMMERCE  
NATIONAL BUREAU OF STANDARDS  
INSTITUTE FOR BASIC STANDARDS  
BOULDER, COLORADO 80302

SAMPLE

REPORT OF CALIBRATION

RF MICROPOTENTIOMETER

Submitted by:

The measurements on this instrument were performed under ambient conditions of approximately 23<sup>o</sup>C and 40 percent relative humidity.

Determinations were made of the difference between the r-f and d-c output voltages required for the same thermocouple output. The r-f and d-c voltage determinations were made with the resistive element terminated in 50-ohms. The resistance of the resistive element was measured with d-c and found to be 10.58 milliohms when terminated in 50-ohms. The observed differences are given in the table below, where a positive sign indicates that the r-f output voltage of the RF Micropotentiometer is greater than the d-c value.

Page 1 of 2  
Test No.  
Date:

## RF Micropotentiometer

The RF-DC difference values are correct within the percentages presented in the table.

<u>Frequency</u> <u>MHz</u>	<u>RF-DC Difference</u> <u>percent</u>	<u>Accuracy</u> <u>percent</u>
5	-1.4	
100	-2.1	
300	-1.3	
400	-0.7	
500	+0.1	
700	+2.0	
900	+3.8	

For the Director,  
Institute for Basic Standards

High Frequency Calibration Services  
Radio Standards Engineering Division

Page 2 of 2  
Test No.  
Date:  
Reference:



The RF-DC correction factor may be used to correct the calculated currents,  $I_{d-c}$ , as follows:

$$I_c = \frac{100 - k}{100} I_{d-c} \quad (2)$$

where

$I_c$  = corrected current in milliamperes,

$k$  = RF-DC difference in percent, and

$I_{d-c}$  = calculated direct current in milliamperes.

Example:

Desired output voltage,  $E = 100$  microvolts

Resistance of radial resistor,  $R = 10.58$  milliohms

Frequency = 700 MHz

Determine the correct current for 100 microvolts at 700 MHz.

From the preceding example on page 13 the direct current required,

$I_{d-c}$ , for 100 microvolts was calculated to be 9.452 milliamperes.

From the Report of Calibration on page 16 the RF-DC difference at

700 MHz is +2.0 percent. The corrected current,  $I_c$ , can now be calculated as follows:

$$\begin{aligned} I_c &= \frac{100 - k}{100} I_{d-c} \\ &= \frac{100 - (2.0)}{100} 9.452 = 9.263 \\ &= 9.263 \text{ milliamperes at } 700 \text{ MHz.} \end{aligned}$$

The measurement of the direct current through the thermoelement and the radial resistor can be illustrated in Figure 2.3.

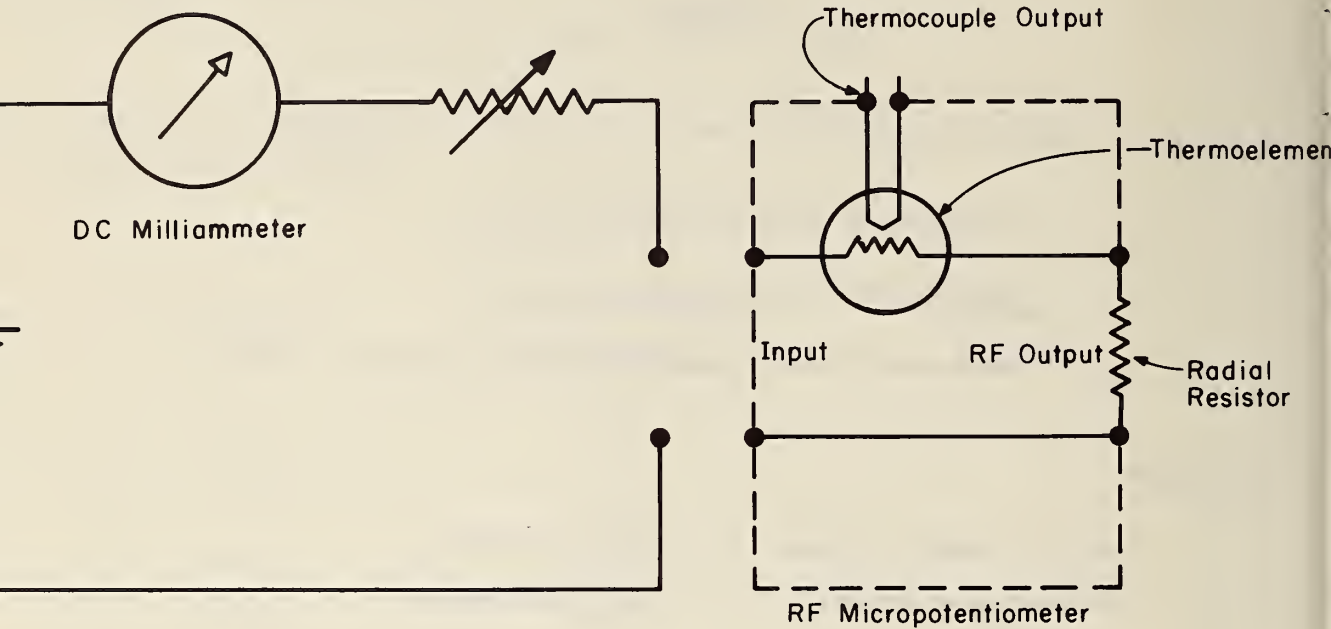

Figure 2.3. DC Calibration of RF Micropotentiometer.

The d-c milliammeter should be a high quality laboratory type instrument capable of measuring direct current to within 0.25 to 0.5%. This current measurement can be accomplished by other methods as illustrated in Figure 2.4 which is a circuit diagram of a highly accurate direct-current milliammeter that utilizes a precision resistor and an accurate millivoltmeter.

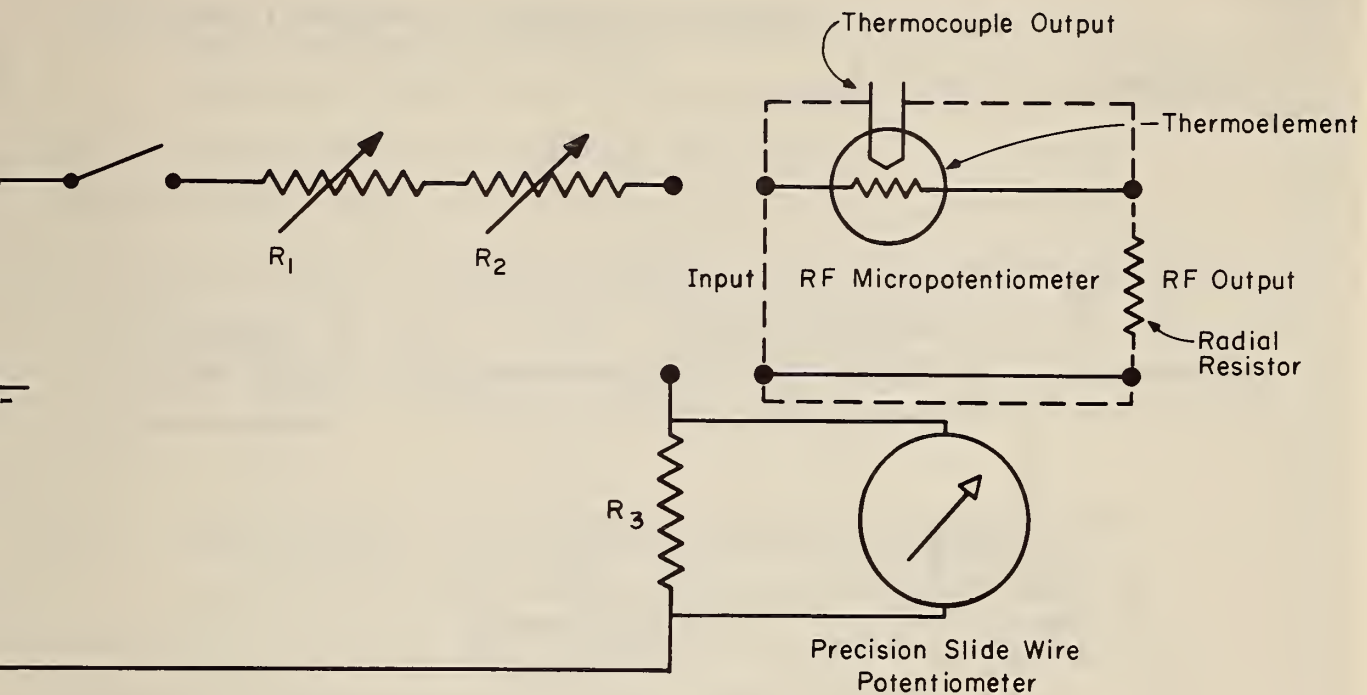

Figure 2.4. Circuit Diagram of a Precision DC Milliammeter.

$R_1$  and  $R_2$  are multi-turn potentiometers,  $R_3$  is a precision 1-ohm resistor, and the millivoltmeter is a precision slide wire potentiometer. The current flowing through the r-f micropotentiometer is the same as the current flowing through the precision resistor,  $R_3$ . By accurately measuring the voltage drop across  $R_3$  the current flow can be determined by simple application of Ohm's Law. One milliamper of current flowing through a 1-ohm resistor will have a 1-millivolt voltage difference across it.

A block diagram of a typical two-terminal r-f voltmeter calibration is illustrated in Figure 2.5.

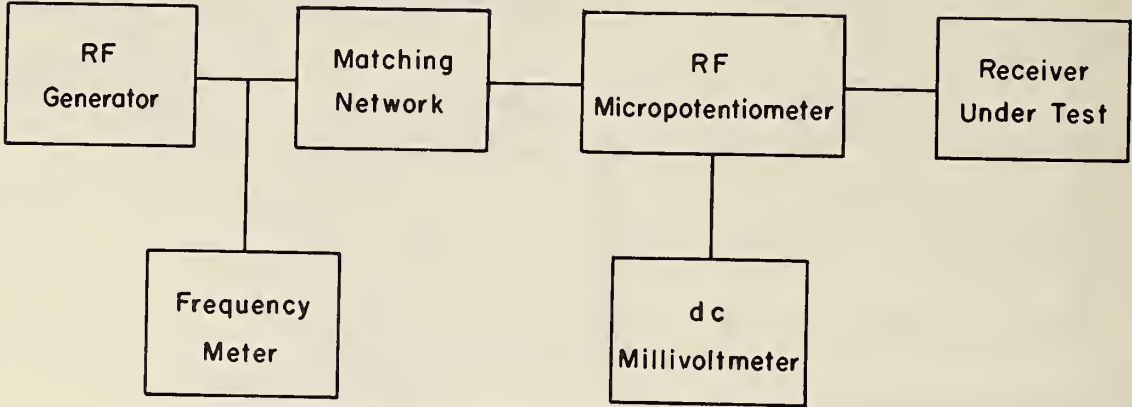

Figure 2.5. Typical Two-Terminal RF Voltmeter Calibration.

The frequency meter may not be required if the dial indicators are within 1 percent on the generator. The matching network may not be required if sufficient power is available from the generator; however, matching stubs are usually required at the higher frequencies in order to achieve sufficient power to the r-f micropotentiometer. The d-c millivoltmeter can be any high quality meter with a 10-millivolt full scale deflection. A low-impedance (10-100 ohms) meter is preferred. The accuracy of this meter is not important, but the repeatability and resolution are very important.

## 2.2 Calibrated Signal Generators.

There may be times when r-f micropotentiometers are not available as voltage standards to calibrate the receivers. A calibrated signal generator can be used to calibrate the receivers but with greater uncertainty which depends on the signal generator used. Most field strength meters have a nominal 50-ohm input impedance; therefore, a calibrated 50-ohm signal generator can be used to inject known voltages into the receiver.

## 2.3 Two-Terminal RF Voltmeter Calibration Uncertainties.

The uncertainties in establishing known voltages at these low levels (10  $\mu$ V to 100 mV) is a function of frequency, i. e., the higher the frequency the greater the uncertainty. One of the more accurate means of establishing known voltages is to use the r-f micropotentiometer. By using a calibrated micropotentiometer and all corrections, voltages can be generated with uncertainties from 3 to 10 percent, depending on the frequency. The following table lists the uncertainties as a function of frequency that can be obtained by using calibrated r-f micropotentiometers:

<u>Frequency range</u> <u>MHz</u>	<u>Uncertainty</u> <u>%</u>
d-c to 100	3 - 4
100 to 500	4 - 6
500 to 1000	6 - 10

If a signal generator is used in place of the r-f micropotentiometer, the uncertainty is usually increased by at least twice the uncertainty listed above. It is obvious that at the higher frequencies the

calibration uncertainty will exceed 1 decibel. At the lower frequencies the uncertainty should be within 1 decibel.

2.4 Procedure for Calibrating the NF-105 as a Two-Terminal RF Voltmeter.

2.4.1 DC Calibration of the Micropotentiometer.

The following equipment is required to provide this calibration:

Slide Wire Potentiometer - range, 0 to 160 mV -  
uncertainty  $\pm 0.1\%$  of reading.

DC Calibration Unit from the Standard Antenna Set  
(see page 151).

DC Millivoltmeter - range 0 to 10 mV.

Calibration Procedure

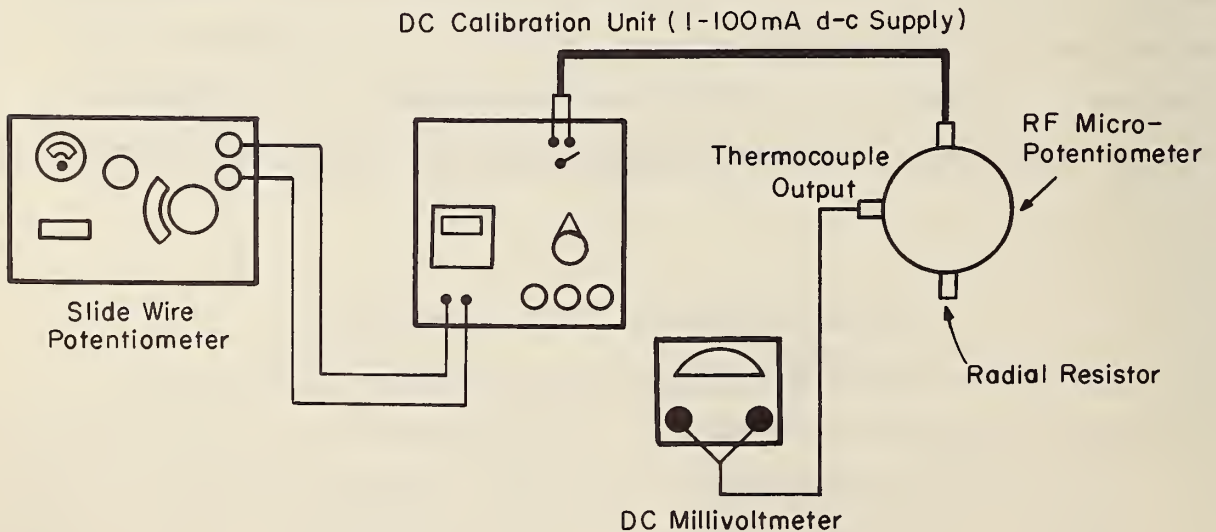

Figure 2.6. RF Micropotentiometer Calibration System Cabling Diagram.

1. Turn the Function Switch of the DC CALIBRATION UNIT to the "OFF" position. Turn the "TEST-CALIB" switch of the "1-10-MA DC SUPPLY" to "TEST".
2. Using the appropriate cable connect the PRECISION SLIDE WIRE POTENTIOMETER to the "TO PRECISION S.W. POTENTIOMETER" jacks of the DC CALIBRATION UNIT as shown in Figure 2.6.
3. Connect the appropriate cable from the "1-10-MA DC SUPPLY" jacks of the DC CALIBRATION UNIT to the r-f input Type N connector of the RF MICROPOTENTIOMETER. The radial resistor N connector of the RF MICROPOTENTIOMETER should have nothing connected to it.
4. Connect the RG-55 split tail cable from the BNC terminal on the RF MICROPOTENTIOMETER to the terminals on the DC MILLIVOLTMETER.

CAUTION: Watch polarity.

5. Zero the SLIDE WIRE POTENTIOMETER.
6. From Example 1, page 24, obtain the value for  $I_c$  of the first frequency and multiply it by 1 ohm to obtain the voltage to be set into the SLIDE WIRE POTENTIOMETER.
7. Set the SLIDE WIRE POTENTIOMETER to read the voltage obtained in step 6.
8. Turn all of the "DC ADJUST" knobs on the DC CALIBRATION UNIT fully counterclockwise.
9. Turn the Function Switch to the "1-10 MA" position.

10. Turn the "COURSE DC ADJUST" knob clockwise until the DC MILLIAMMETER reads just under the value for the corrected current  $I_c$ .
11. Switch the "TEST-CALIB" switch of the "1-10 MA DC SUPPLY" to the "CALIB" position.
12. Depress the contact button on the SLIDE WIRE POTENTIOMETER and adjust the "DC ADJUST" knobs of the DC CALIBRATION UNIT until the SLIDE WIRE POTENTIOMETER is balanced.
13. Record the reading of the DC MILLIVOLTMETER. See Example 1, page 24.
14. Repeat steps 5 through 13.

#### EXAMPLE 1

From Section 2.1 it was found that  $I_{dc} = 9.452$  milliamperes. The RF-DC correction was taken from the curve on page 25, Figure 2.7. This curve was drawn from the data in the Report of Calibration for the r-f micropotentiometer. Using equation, (2), the corrected current is obtained for each frequency above 600 MHz. The table below shows the value of  $I_c$  obtained from the calculations. Also shown are sample readings of the d-c millivoltmeter (step 13, above).

Frequency MHz	RF-DC difference %	$I_c$ mA	Sample Millivoltmeter Readings
0	0	9.452	7.71
700	+2.0	9.263	5.73
800	+2.8	9.187	5.45
900	+3.8	9.093	4.99
1000	+5.0	8.979	4.48



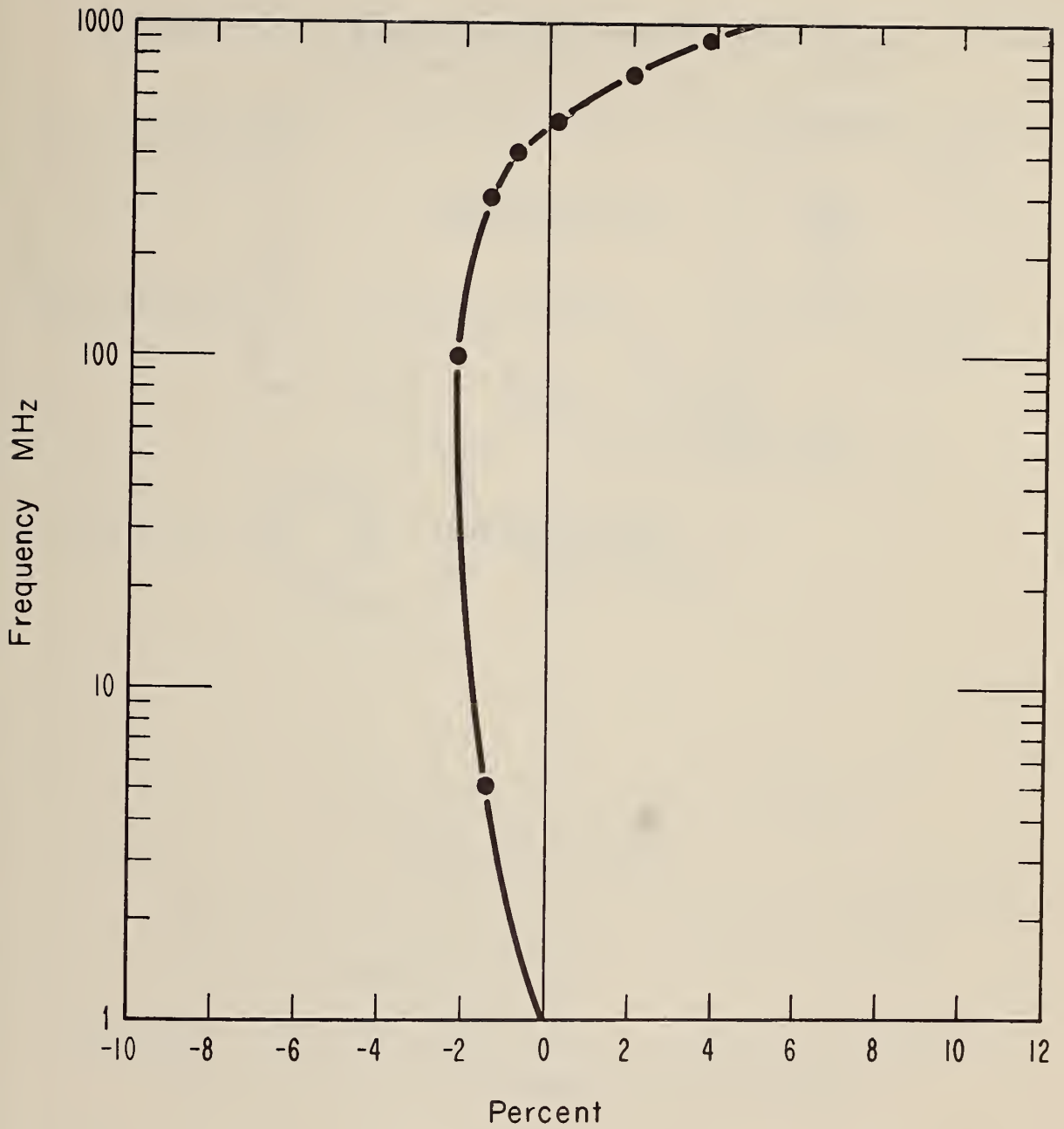

Figure 2.7. Frequency vs RF-DC Difference for the RF Micropotentiometer.

2.4.2 Calibration of the NF-105 Receiver as a Two-Terminal RF Voltmeter Using the RF Micropotentiometer.

2.4.2.1 Frequencies to be Calibrated for the TX Tuning Unit.

14 - 25 kHz Band

14

17

21

23

25

25 - 62 kHz Band

25

35

45

55

62

62 - 150 kHz Band

62

85

105

125

150

The following equipment is required to provide this calibration:

Signal Generator - frequency range, 30 Hz to 30 MHz  
output, 3 volts into 50 ohms.

DC Millivoltmeter - range 0 to 10 mV.

Calibrated RF Micropotentiometer.

## Calibration Procedure

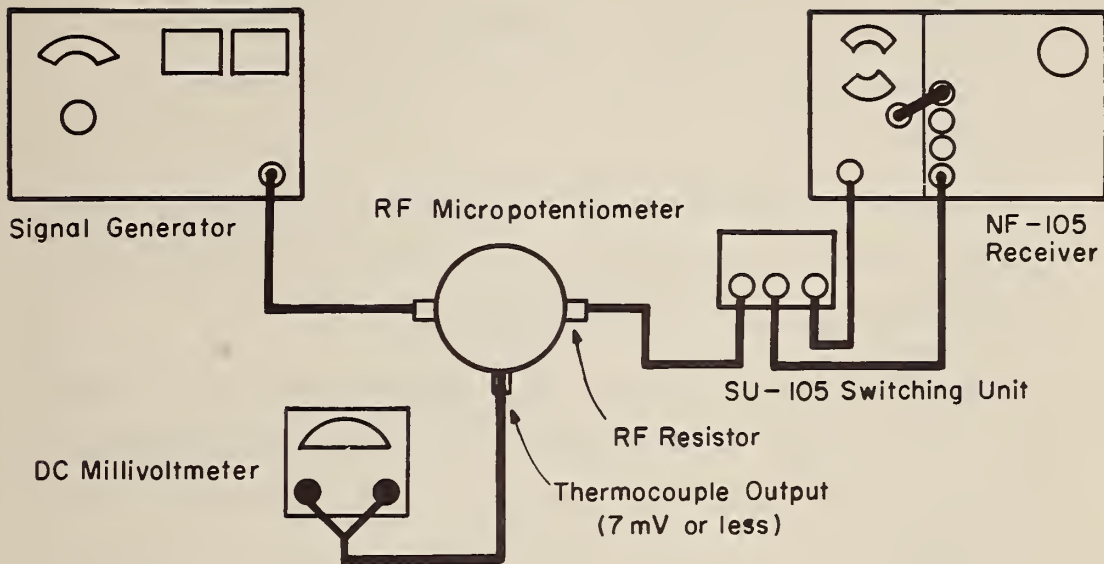

Figure 2.8. Two-Terminal RF Voltmeter Calibration System Cabling Diagram.

1. Connect an 18-inch length of RG-9 cable from the output of the SIGNAL GENERATOR to the input N connector on the RF MICROPOTENTIOMETER.

CAUTION: SIGNAL GENERATOR output should be in low output position to protect the RF MICROPOTENTIOMETER.

2. Connect the 18-inch RG-55 split tail cable from the DC MILLIVOLTMETER to the BNC connector on the RF MICROPOTENTIOMETER.

CAUTION: Watch polarity of the DC MILLIVOLTMETER.

3. Connect the green 30-foot cable from the radial resistive N connector of the RF MICROPOTENTIOMETER to the BNC connector marked "FROM ANTENNA" on the SU-105 SWITCHING UNIT.
4. Turn off RECEIVER and plug TX TUNING UNIT into the MAIN UNIT. Turn on RECEIVER. Allow RECEIVER to warm up an hour before starting calibration.
5. Connect the 6-inch RG-55 COAXIAL CABLE from the terminal on the TX TUNING UNIT marked "TO ATTENUATOR" to the terminal on the MAIN UNIT marked "ATTN OUTPUT".
6. Connect an 18-inch length of RG-55 COAXIAL CABLE from the terminal on the TUNING UNIT marked "IMPULSE GEN OUTPUT" to the terminal on the SU-105 SWITCHING UNIT marked "TO IMPULSE GENERATOR".
7. Connect an 18-inch length of RG-55 COAXIAL CABLE from the terminal on the MAIN UNIT marked "SIGNAL INPUT" to the terminal on the SU-105 SWITCHING UNIT marked "TO SIGNAL INPUT".

8. Set the controls in the following positions:

	<u>CONTROL</u>	<u>POSITION</u>
SU-105 SWITCHING UNIT	Calibrate-Read Switch	"READ"
MAIN UNIT	Function Switch	"CARRIER"
	"SLIDEBACK"	Full CCW
	"IF GAIN"	Midway
	"SIGNAL INPUT ATT."	"20 dB"
	"METER"	"INT"
TX HEAD	"SIG. ATT"	"NORM"
	"BFO"	"OFF"
	"IMPULSE GEN"	"OFF"
	Band Switch	"1"

Positions of all other controls are of no importance for start of calibration.

9. Set the SIGNAL GENERATOR frequency to 14 kHz.
10. Apply r-f to MICROPOTENTIOMETER until an indication on the DC MILLIVOLTMETER is given that is just below the Millivoltmeter indication recorded during d-c calibration of the MICROPOTENTIOMETER. See Example 1, page 24.

CAUTION: Never exceed the millivolt indication on the DC MILLIVOLTMETER for any given frequency, as it is possible to burn out the thermoelement in the MICROPOTENTIOMETER.

11. Tune the RECEIVER until a maximum indication is shown on the Read-Out Meter. If the meter indication is off scale, reduce or increase the "IF GAIN" until an on-scale indication is obtained. Again tune for a maximum indication.

12. Switch the Function Switch of the RECEIVER to "METER BAL" position. Adjust "METER BAL" knob until the Read-Out Meter reads 0.
13. Switch Function Switch to the "ZERO ADJ" knob until the Read-Out Meter reads 0.
14. Repeat steps 12 and 13 until both steps indicate 0 without further adjustment.
15. Switch the Function Switch to the "CARRIER" position.
16. Increase the SIGNAL GENERATOR output until the DC MILLIVOLTMETER indication is the same as the indication recorded during the d-c calibration of the r-f micropotentiometer.

CAUTION: Increase the SIGNAL GENERATOR output slowly. There is a delay in meter indication of the DC MILLIVOLTMETER caused by the time required for the heater of the thermoelement in the MICROPOTENTIOMETER to change temperature.

17. Retune the receiver for maximum indication.
18. Adjust "IF GAIN" control until a full-scale indication "20 dB" on the Read-Out Meter is observed. This gives a total reading of "40 dB", 20 dB on the Read-Out Meter, plus 20 dB in "SIGNAL INPUT ATTENUATOR". This is equivalent to 100  $\mu$ V.
19. Change switch on SU-105 SWITCHING UNIT from "READ" to "CALIBRATE".
20. Change Function Switch from "CARRIER" to "PEAK".
21. Turn on the impulse generator in TX TUNING UNIT by changing the "IMPULSE GENERATOR" switch from "OFF" to "ON".

22. Adjust the "IMPULSE GENERATOR LEVEL" by rotating the outer knob clockwise to increase the level in 10 dB increments, and the inner knob clockwise to increase the level in 1 dB increments. Adjust the "IMPULSE GENERATOR LEVEL" until the Read-Out Meter indicates between 19 and 20 dB.
23. The difference between the Read-Out Meter indication and the 20 dB point in tenths of a dB, plus the readings from the "IMPULSE GENERATOR LEVEL" knobs gives the "CAL SETTING".

EXAMPLE

	<u>Reading</u>
Outer Knob	70 dB
Inner Knob	4 dB
Tenths of dB between needle and 20 dB mark	<u>0.3 dB</u>
Cal Setting	74.3 dB

24. Record the "CAL SETTING". See Figure 2.10, page 38.
25. Repeat steps 10 through 24 three times. Average the three "CAL SETTINGS" for a final "CAL SETTING".
26. Change the SIGNAL GENERATOR to next frequency listed on page 26 and repeat steps 10 through 26.

2.4.2.2 Frequencies to be Calibrated for the TA Tuning Unit.

0.15 - 0.36 MHz Band

0.15

0.22

0.29

0.36

0.36 - 0.86 MHz Band

0.36

0.50

0.65

0.86

0.86 - 2.1 MHz Band

0.86

1.2

1.6

2.1

2.1 - 5.2 MHz Band

2.1

3.0

4.0

5.2

5.2 - 12.7 MHz Band

5.2

7.5

10.0

12.7

12.7 - 30 MHz Band

12.7

18.0

24.0

30.0



The following equipment is required to provide this calibration:

Signal Generator - frequency range 0.15 to 30 MHz -  
output 3 volts into 50 ohms.

Calibrated RF Micropotentiometer.

DC Millivoltmeter - range 0 to 10 millivolts.

### Calibration Procedure

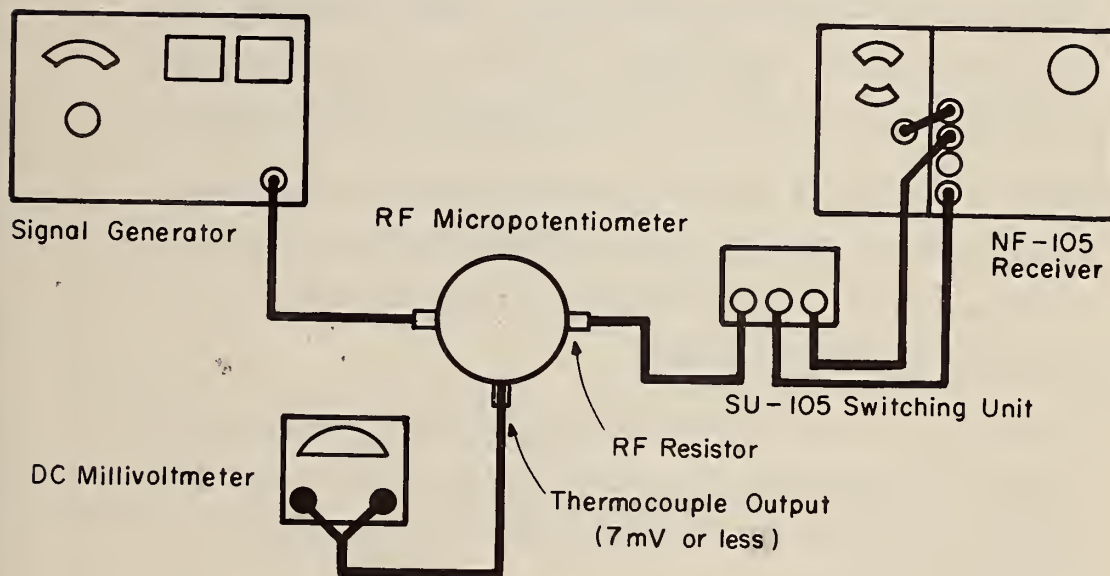

Figure 2.9. Two-Terminal RF Voltmeter Calibration System Cabling Diagram.

1. Connect an 18-inch length of RG-9 cable from the output of the SIGNAL GENERATOR to the input N connector on the RF MICROPOTENTIOMETER.

CAUTION: SIGNAL GENERATOR output should be in a low output position to protect the MICROPOTENTIOMETER.

2. Connect the 18-inch RG-55 split tail cable from the DC Millivoltmeter to the BNC connector on the MICROPOTENTIOMETER.

CAUTION: Watch polarity of the DC Millivoltmeter.

3. Connect the green 30-foot cable from the radial resistive N connector of the MICROPOTENTIOMETER to the BNC connector marked "FROM ANTENNA" on the "SU-105 SWITCHING UNIT".
4. Turn off RECEIVER and plug the TA TUNING UNIT into the MAIN UNIT. Turn on the RECEIVER. Allow RECEIVER to warm up an hour before start of calibration.
5. Connect the 6-inch RG-55 COAXIAL CABLE from the terminal on the TA TUNING UNIT marked "TO ATTENUATOR" to the terminal on the MAIN UNIT marked "ATTN OUTPUT".
6. Connect an 18-inch RG-55 COAXIAL CABLE from the terminal on the MAIN UNIT marked "IMPULSE GEN" to the terminal on the SU-105 SWITCHING UNIT marked "TO IMPULSE GENERATOR".
7. Connect an 18-inch RG-55 COAXIAL CABLE from the terminal on the MAIN UNIT marked "SIGNAL INPUT" to the terminal on the SU-105 (SWITCHING UNIT) marked "TO SIGNAL INPUT".

	<u>CONTROL</u>	<u>POSITION</u>
SU-105 SWITCHING UNIT	Calibrate-Read Switch	"READ"
MAIN UNIT	Function Switch	"CARRIER"
	"SLIDEBACK"	Full CCW
	"IF GAIN"	Midway
	"SIGNAL INPUT ATT"	"20 dB"
	"METER"	"INT."
	"SINE WAVE OSC - IMPULSE GEN SW"	"OFF"
TA HEAD	Band Selector	".15 - .36"

Position of all other controls are of no importance for start of calibration.

8. Apply the r-f signal to the RF MICROPOTENTIOMETER until an indication on the DC MILLIVOLTMETER is given that is just below the indication recorded during the d-c calibration of the RF MICROPOTENTIOMETER.

CAUTION: Never exceed the d-c calibration indication on the DC MILLIVOLTMETER as it is possible to burn out the thermoelement in the MICROPOTENTIOMETER.

9. Tune the RECEIVER until a maximum indication is shown on the Read-Out Meter in the MAIN UNIT. If the meter is off scale, reduce or increase the "IF GAIN" until an on-scale indication is obtained. Again tune for a maximum indication.
10. Switch the Function Switch to the "METER BAL" position. Adjust the "METER BAL" knob until the meter reads 0.
11. Switch Function Switch to the "ZERO ADJ". Adjust "ZERO ADJ" knob until meter reads 0.
12. Repeat steps 10 and 11 until both steps indicate 0 without further adjustment.
13. Switch Function Switch to "CARRIER" position.
14. Increase the SIGNAL GENERATOR output until the DC MILLIVOLTMETER indication is the same as the indication given in the MICROPOTENTIOMETER calibration.

CAUTION: Increase the SIGNAL GENERATOR output slowly. There is a delay in the DC MILLIVOLTMETER indication caused by the time required for the heater of the thermoelement in the MICROPOTENTIOMETER to change temperature.

15. Check tuning for maximum indication.
16. Adjust the "IF GAIN" control until a full scale indication, 20 dB, on the Read-Out Meter of the receiver is observed. This gives a total reading of 40 dB, 20 dB on the Read-Out Meter, plus 20 dB in the "SIGNAL INPUT ATTENUATOR". This is equivalent to 100  $\mu$ V.
17. Change switch on SU-105 SWITCHING UNIT from "READ" to "CALIBRATE".
18. Change Function Switch from "CARRIER" to "PEAK".
19. Turn on the Impulse Generator in the MAIN UNIT by changing the "SINE WAVE OSC." - "IMPULSE GEN." switch from "OFF" to "IMPULSE GEN.".
20. Adjust the "IMPULSE GEN. OUTPUT dB ABOVE 1  $\mu$ V/Mc" attenuators until the Read-Out Meter reads as close to full scale as possible using the 10-dB steps of the attenuator.
21. Adjust the "ADD TO IMPULSE GEN. OUTPUT" control until a full-scale meter reading (20 dB) is obtained on the Read-Out Meter of the receiver.
22. Add the dB reading from the "ADD TO IMPULSE GEN. OUTPUT" meter to the "IMPULSE GEN. OUTPUT dB ABOVE 1  $\mu$ V/Mc" attenuator setting to obtain the CAL SETTING as shown on the next page.

"ADD TO IMPULSE GEN. OUTPUT"	
Meter Reading	+ 3.2 dB
"IMPULSE GEN. OUTPUT dB ABOVE 1 $\mu$ V/Mc"	
Attenuator Setting	<u>70.0 dB</u>
Cal Setting	73.2 dB
"ADD TO IMPULSE GEN. OUTPUT"	
Meter Reading	- 1.2 dB
"IMPULSE GEN. OUTPUT dB ABOVE 1 $\mu$ V/Mc"	
Attenuator Setting	<u>80.0 dB</u>
Cal Setting	78.8 dB

24. Record the CAL SETTING. See Figure 2.10, page 38.
25. Repeat steps 8 through 24 three times. Average the three CAL SETTINGS. See Figure 2.10, page 38.
26. Change the frequency of the SIGNAL GENERATOR to the next frequency listed on page 32 and repeat steps 8 through 25.



2.4.2.3 Frequencies to be calibrated for the T-1, T-2, and T-3 Tuning Units.

T-1 TUNING UNIT

20 - 65 MHz Band

20

30

35

50

65

65 - 200 MHz Band

65

100

150

200

T-2 TUNING UNIT

200 - 400 MHz Band

200

250

300

350

400

T-3 TUNING UNIT

400 - 700 MHz Band

400

500

600

700

## T-3 TUNING UNIT

### 700 - 1000 MHz Band

700

800

900

1000

The following equipment is required to provide this calibration:

Signal Generator - frequency range 20 to 1000 MHz -  
output 500 millivolts into 50 ohms

Calibrated RF Micropotentiometer

DC Millivoltmeter - range 0 to 10 millivolts

The calibration procedure for the T-1, T-2, and T-3 Tuning Units is the same as for the TA Tuning Unit.



### 3.0 CALIBRATION OF FIM SIGNAL ATTENUATORS

#### 3.1 General Discussion

The signal attenuators of the FIM are calibrated using a straightforward r-f substitution technique. This is illustrated in Figure 3.1. The signal attenuators are calibrated in terms of a standard attenuator. As the signal attenuation of the FIM is reduced, attenuation is added with the standard attenuator to maintain a pre-selected level on the readout of the FIM. The change in attenuation of the standard attenuator indicates the correct attenuation of the signal attenuators. From this a correction factor can be determined.

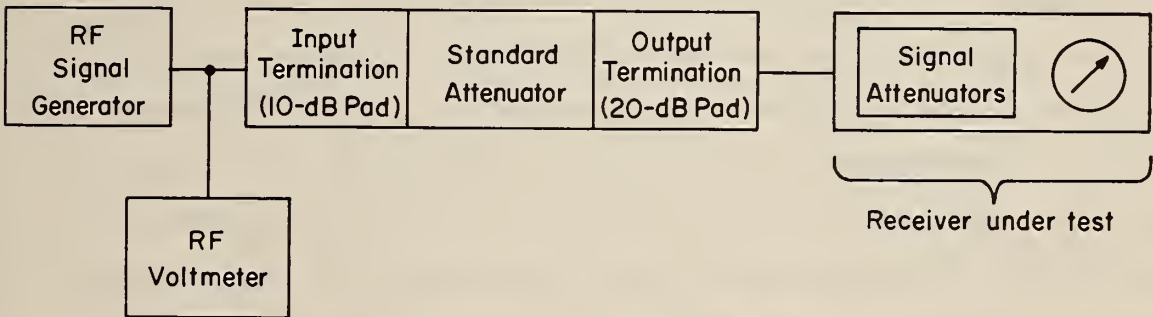

Figure 3.1. Measurement Of Signal Attenuator Ratios.

The standard attenuator must be a calibrated r-f attenuator with a 60-dB range in 0.1 dB increments. The 20-dB output pad is important to the standard attenuator because it provides the standard attenuator with a constant terminating impedance and serves as an isolator. The 10-dB pad at the input of the standard attenuator provides some isolation between the signal generator and the standard attenuator, and helps provide stable signal levels. The 10-dB pad may be removed if necessary for the calibration of higher steps of the signal attenuators, but a close watch must be maintained on the input signal level.

The signal attenuators should be calibrated at a high and a low frequency, and also at a medium frequency, if the frequency range is large or the signal attenuators are frequency sensitive. If an FIM has IF attenuators and there are several intermediate frequencies, it is usually wise to be certain all are calibrated.

### 3.2 Attenuator Ratio Measurement Uncertainties.

The chief requirements of an accurate attenuation measurement system include stable calibrated standard attenuators, excellent shielding of all components from the r-f source to the detector, and stable r-f sources. Shielding cannot be overemphasized, because the lack of adequate shielding can introduce an appreciable error. The range of attenuator measurements associated with FIM calibrations can be as high as 100 decibels, and extreme care must be taken with all components to insure accurate measurements. One source of r-f leakage that is often overlooked is the r-f connector. It is often necessary to wrap them in a shielding material such as aluminum foil when making high-level attenuation measurements. By using a calibrated standard attenuator and a properly-designed system, measurements can be made to within  $0.1 \text{ dB} + 0.3\%$  of the attenuation in decibels (which is approximately 2 percent) from d-c to 400 MHz, and  $0.1 \text{ dB} + 0.5\%$  of the attenuation in decibels (which is approximately 3 percent) from 400 to 1000 MHz.

### 3.3 Procedure for Calibrating the NF-105 Signal Attenuators:

Calibration frequencies:

150 kHz

300 MHz

1000 MHz

The following equipment is required to provide this calibration:

Signal Generator - frequency range 150 kHz to 1000 MHz -  
output 500 millivolts into 50 ohms

Standard Attenuator - 60 dB maximum attenuation with  
0.1 dB steps

RF Voltmeter - frequency range 150 kHz to 1000 MHz

Calibration Procedure

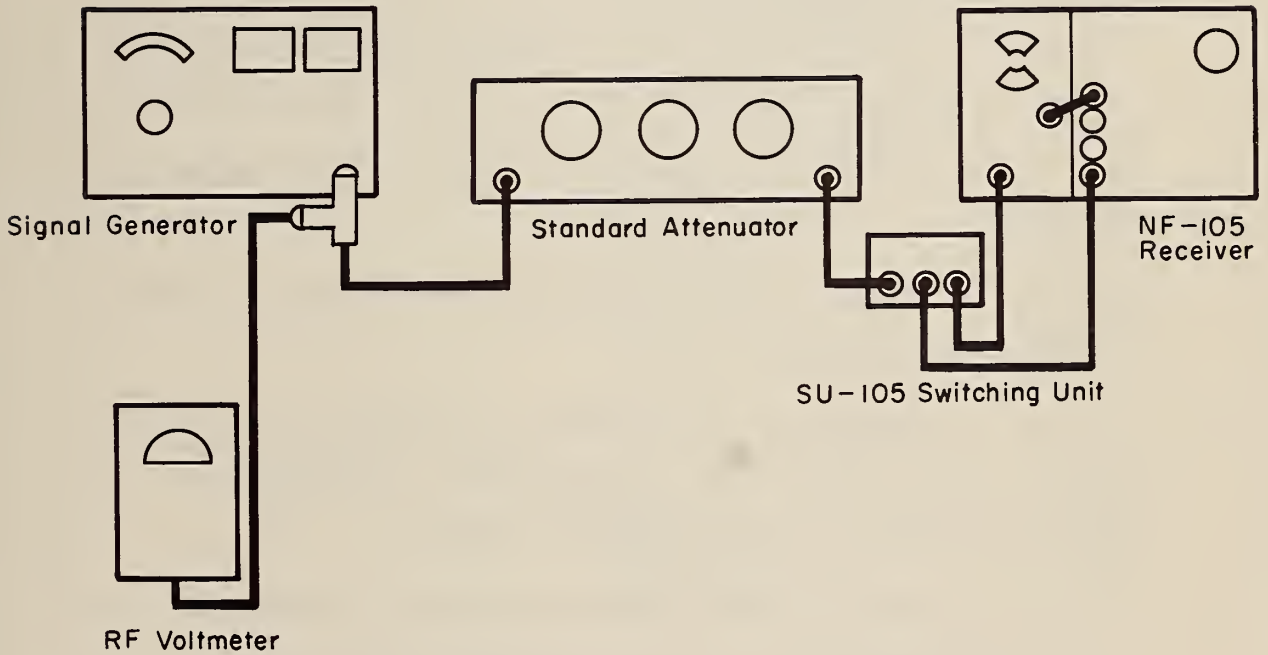

Figure 3.2. Signal Attenuator Calibration  
System Cabling Diagram.

1. Connect the T-Connector to the output of the SIGNAL GENERATOR.
2. Connect the probe of the RF VOLTMETER to the T-Connector.
3. Connect a short length of RG-9 cable from the female N connector of the T-Connector to the female N connector of the 10-dB pad attached to the input of the STANDARD ATTENUATOR.
4. Connect one end of the green 30-foot RG-55 cable with an N-to-BNC adapter to the female N connector of the 20-dB pad on the output of the STANDARD ATTENUATOR. Connect the other end of the green 30-foot RG-55 cable to the BNC-female connector marked "FROM ANTENNA" on the SU-105 SWITCHING UNIT.
5. Turn off RECEIVER and plug the TX TUNING UNIT into the MAIN UNIT.
6. Turn on RECEIVER. Allow a one-hour warm-up period before starting the calibration.
7. Connect the 6-inch RG-55 cable from the terminal on the TX TUNING UNIT marked "TO ATTENUATOR" to the terminal on the MAIN UNIT marked "ATTEN. OUTPUT".
8. Connect an 18-inch length of RG-55 cable from the terminal on the TX TUNING UNIT marked "IMPULSE GEN OUTPUT" to the terminal on the SU-105 SWITCHING UNIT marked "TO IMPULSE GENERATOR".
9. Connect an 18-inch length of RG-55 cable from the terminal on the MAIN UNIT marked "SIGNAL INPUT" to the terminal on the SU-105 SWITCHING UNIT marked "TO SIGNAL INPUT".

10. Set the controls in the following positions:

	<u>CONTROL</u>	<u>POSITION</u>
SIGNAL GENERATOR	"MODULATION SELECTOR"	"CW"
	"VERNIER ATTENUATOR"	"1 MICRO- VOLT"
STANDARD ATTENUATOR	10 dB STEP DRUM	"0 dB"
	1 dB STEP DRUM	"0 dB"
	2 to 2.9 dB STEP DRUM	"2.5 dB"
SU-105 SWITCHING UNIT	Calibrate-Read Switch	"READ"
	MAIN UNIT	
	Function Switch	"CARRIER"
	"SLIDEBACK"	Full CCW
	"IF GAIN"	Midway
	"SIGNAL INPUT ATT."	"20 dB"
	"METER"	"INT."
TX TUNING UNIT	"SIG ATT"	"NORM"
	"BFO"	"OFF"
	"IMPULSE GEN."	"OFF"
	Band Switch	"3"

Position of all other controls are of no importance for start of calibration.

11. Set the frequency of the SIGNAL GENERATOR to 150 kHz.
12. Increase the output from the SIGNAL GENERATOR to approximately 3 millivolts.
13. Tune the RECEIVER for maximum indication on the meter. If an off-scale reading is observed, reduce or increase the SIGNAL GENERATOR output until an on-scale reading is acquired. Again, tune the RECEIVER for maximum deflection.

14. Calibrate the RECEIVER in accordance with the instruction manual using the "CAL SETTING" found in Section 2.4 for 150 kHz.
15. Switch the READ, CALIBRATE SWITCH on the SU-105 SWITCHING UNIT to "READ".
16. Tune RECEIVER again for maximum indication.
17. Place the "SIGNAL INPUT ATTENUATOR" in the "80 dB" position.
18. Increase the output of the SIGNAL GENERATOR until an on-scale reading of the meter is observed.

NOTE: The 10-dB pad on the input of the STANDARD ATTENUATOR may be removed for this one step to obtain an on-scale reading.

CAUTION: Do not exceed the maximum voltage rating of the STANDARD ATTENUATOR.

19. Adjust the SIGNAL GENERATOR output until a convenient reference point on the meter is obtained. If possible a full-scale or 20-dB reading is best, but if this is not possible, then any point or marking on the upper half of the meter that can be accurately read.
20. Add 20 dB with the STANDARD ATTENUATOR.
21. Change the "SIGNAL INPUT ATTENUATOR" from the "80 dB" position to the "60 dB" position.
22. Adjust the STANDARD ATTENUATOR until the meter on the MAIN UNIT again reads the reference point of step 19.
23. Record the reading from the STANDARD ATTENUATOR. See Figure 3.3, page 50.

24. Change the "SIGNAL INPUT ATTENUATOR" back to the "80 dB" position.
25. Remove the added attenuation from the STANDARD ATTENUATOR.
26. The meter on the MAIN UNIT should again read the reference point of step 19. If the meter needle does not come back to the reference point, the measurement will be in error and have to be repeated. The RF VOLTMETER reading should be monitored throughout the measurement to maintain the output voltage from the SIGNAL GENERATOR.
27. Steps 16 through 26 should be repeated three times and the results of step 23 averaged. See Figure 3.3, page 50.
28. Adjust the SIGNAL GENERATOR output until a convenient reference point on the meter is obtained. If possible a full-scale or 20-dB reading is best, but if this is not possible, select any point on the upper half of the meter that can be accurately read.
29. Add 40 dB of attenuation with the STANDARD ATTENUATOR.
30. Change the "SIGNAL INPUT ATTENUATOR" from the "80 dB" position to the "40 dB" position.
31. Adjust the STANDARD ATTENUATOR until the meter on the MAIN UNIT again reads the reference point of step 28.
32. Record the reading from the STANDARD ATTENUATOR. See Figure 3.3, page 50.
33. Change the "SIGNAL INPUT ATTENUATOR" back to the "80 dB" position.
34. Remove the added attenuation from the STANDARD ATTENUATOR.

35. The meter on the MAIN UNIT should again read the reference point of step 28. If the needle does not come back to the reference point, the measurement will be in error and have to be repeated. The RF VOLTMETER reading should be monitored throughout the measurement to maintain the output voltage of the SIGNAL GENERATOR constant.
36. Repeat steps 28 through 35 three times and average the result of step 32. This will be used later as a cross check. See Figure 3.3, page 50.
37. Replace the 10-dB pad to the input of STANDARD ATTENUATOR if it has been removed.
38. Reduce the output of the SIGNAL GENERATOR by 20 dB.
39. Set the frequency of the SIGNAL GENERATOR to 150 kHz.
40. Place the "SIGNAL INPUT ATTENUATOR" in the "60 dB" position.
41. Tune the receiver for maximum indication on the meter. If an off-scale reading is observed reduce or increase the SIGNAL GENERATOR output until an on-scale reading is acquired. Again, tune the receiver for maximum deflection.
42. Adjust the output of the SIGNAL GENERATOR until a full-scale reading (20 dB) is obtained on the meter.
43. Add 20 dB to the STANDARD ATTENUATOR.
44. Change the "SIGNAL INPUT ATTENUATOR" from the "60 dB" position to the "40 dB" position.
45. Adjust the STANDARD ATTENUATOR until the meter on the MAIN UNIT again reads full scale (20 dB).



46. Record the reading from the STANDARD ATTENUATOR. See Figure 3.3, page 50.
47. Change the "SIGNAL INPUT ATTENUATOR" back to the "60 dB" position.
48. Remove the added attenuation from the STANDARD ATTENUATOR.
49. The meter on the MAIN UNIT should return to full scale (20 dB). If the needle does not come back to full scale (20 dB) the measurement is in error and must be repeated.
50. Repeat steps 41 through 49 three times and average the results. See Figure 3.3, page 50.
51. The average results of steps 23 and 50 when added together should be the same as the average results of step 32. If there is a difference greater than 0.1 dB, the measurements will have to be repeated until agreement is reached. See Figure 3.3, page 50.
52. The above procedure is repeated for the rest of "SIGNAL INPUT ATTENUATOR" positions.
53. The Calibration Procedure is repeated for the remaining two frequencies. The TX TUNING UNIT is replaced by the appropriate tuning unit for each frequency.

U. S. DEPARTMENT OF COMMERCE  
NATIONAL BUREAU OF STANDARDS

DATE 12-12-66

SHEET NO. 2

OBSERVER JEC

KIND OF MEASUREMENT Attenuator Calibration

INSTRUMENT TESTED NF-105 Ser. No. 1965 TA Tuning Unit TEST No. 920362

FREQUENCY 150 kHz ROOM TEMPERATURE \_\_\_\_\_ °C. HUMIDITY \_\_\_\_\_ % BAROMETER \_\_\_\_\_ MM.

Gain standardized, function switch in "carrier"

GPO : 1966 O-217-724

Signal	Standard	Attenuator	Reading				
Attn. Pos.				Ave.			
dB	dB	dB	dB	dB			
80	0-0-2.5	0-0-2.5	0-0-2.5	2.5			
60	20-1-2.1	20-1-2.0	20-1-2.1	23.07			
60	0-0-2.5	0-0-2.5	0-0-2.5	2.5			
40	20-0-2.5	20-0-2.5	20-0-2.5	22.5			
40							
20							
20							
0							
80							
40							
40							
0							

Figure 3.3. Sample Data Sheet For Attenuator Calibration.

## 4.0 CALIBRATION OF THE FIM OVERALL LINEARITY

### 4.1 General Discussion

The readout system of the receiver, which is usually a panel meter, indicates the field strength either in microvolts or decibels above 1 microvolt. Either of these units can be used for field strength measurements. The ideal FIM will be perfectly linear, and the panel meter will always indicate the correct reading. However, nonlinearities do exist and can cause errors of several decibels in some cases. These nonlinearities can exist in the r-f section (including the r-f amplifiers and mixer), the IF amplifiers, the metering circuits, and the panel meter. Because the linearity of the FIM is measured from the signal input connector to the panel output meter, it is called overall linearity and includes corrections for all nonlinearities within the FIM. Experience has shown that most of the nonlinearities will occur in the IF section of the receiver, although this is not always the case. It is usually advisable to calibrate the FIM at sufficient frequencies to include each IF amplifier.

The measurement setup for measuring overall linearity is the same as the setup for calibrating the signal attenuators. Overall linearity is essentially an attenuator ratio measurement relating the change in input voltage to the FIM to the indicated voltage on the panel meter. If the input signal is changed by 10 decibels, the panel meter should indicate the exact same change. If the panel meter indicates a change of 10.5 decibels, a linearity error exists.

A point on the panel meter is selected (usually full scale) as being the reference point for all measurements. This point is used to reference corrections to all other indicator points on the panel meter. The calibration is performed by starting out with a full scale indication

A point on the panel meter is selected (usually full scale) as being the reference point for all measurements. This point is used to reference corrections to all other indicator points on the panel meter. The calibration is performed by starting out with a full scale indication on the panel meter and increasing attenuation in the standard attenuator while recording the amount of attenuation required to make the panel meter indicate various readings. A sufficient number of points on the panel meter should be calibrated in order that the indicated panel meter readings can be plotted against the corrected panel meter readings.

#### 4.2 Overall Linearity Measurement Uncertainties.

The chief requirements of an accurate overall linearity measurement system are essentially the same as those for the attenuator calibration system. These include stable r-f sources, good shielding of the entire system, and high-quality components. By using a calibrated standard attenuator and a properly designed system, measurements can be made to within  $0.1 \text{ dB} + 0.3\%$  of the attenuation in decibels (which is approximately 2 percent) from d-c to 400 MHz, and  $0.1 \text{ dB} + 0.5\%$  of the attenuation in decibels (which is approximately 3 percent) from 400 to 1000 MHz.

#### 4.3 Procedure for Calibrating the Overall Linearity of the NF-105 .

Calibration frequencies

TX Tuning Unit	90	kHz
TA Tuning Unit	1.5	MHz
	30	MHz
T1 Tuning Unit	200	MHz
T2 Tuning Unit	300	MHz
T4 Tuning Unit	1000	MHz

The following equipment is required to provide this calibration:

Signal Generator - frequency range, 90 kHz to 1000 MHz -  
output, 500 millivolts into 50 ohms.

Standard Attenuator - 60-dB maximum attenuation within 0.1 dB  
steps.

RF Voltmeter - frequency range 90 kHz to 1000 MHz.

Calibration Procedure

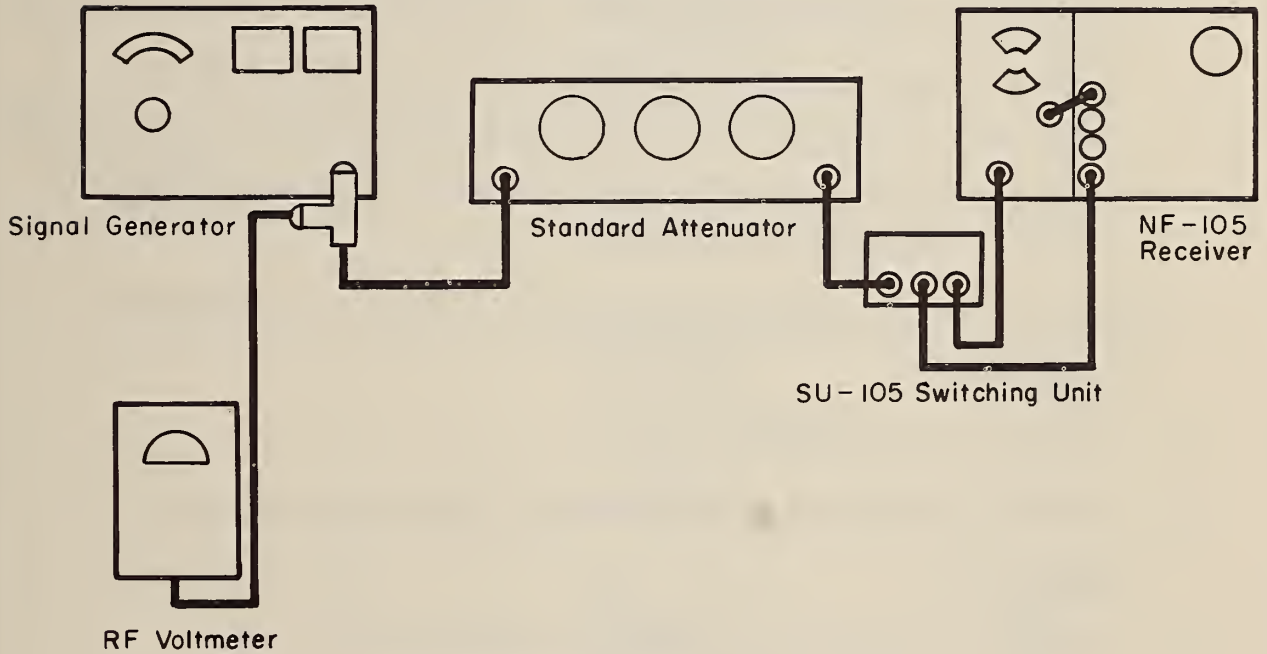

Figure 4.1. Overall Linearity Calibration System Cabling Diagram.

1. Connect the T-Connector to the output of the SIGNAL GENERATOR, as shown in Figure 4.1.
2. Reduce the output from the SIGNAL GENERATOR to its lowest output.
3. Connect the probe of the RF VOLTMETER to the T-Connector.
4. Connect a short length of RG-9 cable from the T-Connector to the 10-dB pad attached to the input of the STANDARD ATTENUATOR.
5. Using an adapter, connect one end of the green 30-foot RG-55 cable to the 20-dB pad on the output of the STANDARD ATTENUATOR. Connect the other end to the connector marked "FROM ANTENNA" on the SU-105 SWITCHING UNIT.
6. Turn off the RECEIVER and plug the TX TUNING UNIT into the MAIN UNIT.
7. Turn on the RECEIVER.
8. Allow the RECEIVER to warm up for an hour before starting calibration.
9. Connect the 6-inch RG-55 cable from the terminal on the TX TUNING UNIT marked "TO ATTENUATOR" to the terminal on the MAIN UNIT marked "ATTEN. OUTPUT".
10. Connect an 18-inch RG-55 cable from the terminal on the TX TUNING UNIT marked "IMPULSE GEN OUTPUT" to the terminal on the SU-105 SWITCHING UNIT marked "TO IMPULSE GENERATOR".
11. Connect an 18-inch RG-55 cable from the terminal on the MAIN UNIT marked "SIGNAL INPUT" to the terminal on the SU-105 (SWITCHING UNIT) marked "TO SIGNAL INPUT".

12. Set the controls in the following positions:

	<u>CONTROL</u>	<u>POSITION</u>
SIGNAL GENERATOR	"MODULATION SELECTOR"	"CW"
	"VERNIER ATTENUATOR"	"1 MICRO- VOLT"
STANDARD ATTENUATOR	10-dB STEP DRUM	"0 dB"
	1-dB STEP DRUM	"0 dB"
	2 to 2.9 dB STEP DRUM	"2.5 dB"
SU-105 SWITCHING UNIT	Calibrate-Read Switch	"READ"
MAIN UNIT	Function Switch	"CARRIER"
	SLIDEBACK"	Full CCW
	"IF GAIN"	Midway
	"SIGNAL INPUT ATTN."	"20 dB"
	"METER"	"INT."
TX TUNING UNIT	"SIG. ATT."	"NORM"
	"BFO"	"OFF"
	"IMPULSE GEN."	"OFF"
	Band Switch	"3"

Positions of all other controls are of no importance for start of calibration.

13. Tune the SIGNAL GENERATOR to 90 kHz.

14. Increase the output from the SIGNAL GENERATOR to approximately 3 millivolts.

15. Tune the RECEIVER for maximum indication on the meter. If an off-scale reading is observed, reduce or increase the output of the SIGNAL GENERATOR as required to obtain an on-scale reading and tune for maximum indication on the meter.
16. Switch the READ CALIBRATE SWITCH on the SU-105 SWITCHING UNIT to the "CALIBRATE" position.
17. Reduce the output of the SIGNAL GENERATOR to its lowest output.
18. Calibrate the RECEIVER in accordance with the instruction manual using the CAL SETTING for this frequency found in the TWO-TERMINAL RF VOLTMETER CALIBRATION Section 2.4.
19. Switch the READ CALIBRATE SWITCH on the SU-105 SWITCHING UNIT to the "READ" position.
20. Re-tune the RECEIVER for maximum indication on the meter.
21. Increase the output of the SIGNAL GENERATOR until a full scale ( $10\ \mu\text{V}$ ) indication is obtained on the meter.
22. Note voltage level on the monitor RF VOLTMETER.
23. Add attenuation with the STANDARD ATTENUATOR until a meter reading of  $9\ \mu\text{V}$  is observed on the RECEIVER.
24. Record the amount of attenuation required from the STANDARD ATTENUATOR to obtain step 23. See Figure 4.2, page 58.
25. Take out the added attenuation from the STANDARD ATTENUATOR and see if the meter reads full scale ( $10\ \mu\text{V}$ ). If a full-scale indication is not obtained, the measurement is in error and steps 20 through 24 must be repeated.



26. Repeat steps 20 through 24 three times and average the results. The results are recorded as shown in Figure 4.2, page 58.
27. Repeat steps 20 through 24 for the other meter indications. This will change the meter indication of step 23 from 9 to 8 to 7 to 6, et cetera.
28. The calibration procedure is repeated for each tuning unit with its required frequency. The TA Tuning Unit has two required frequencies because of the two IF strips used in the tuning unit.

KIND OF MEASUREMENT Overall Linearity

INSTRUMENT TESTED NF-105 S.N. 1965 TX Tuning Head

TEST No. 920362

FREQUENCY 90 kHz ROOM TEMPERATURE °C HUMIDITY % BAROMETER MM.

Gain standardized, attn. pos. = 40 dB

GPO : 1966 O-217-724

reference 10  $\mu$ V

Meter Reading ( $\mu$ V)	Standard dB	Attn. Setting dB		Ave. dB
10	0-0-2.5	0-0-2.5	0-0-2.5	2.5
9	0-1-2.3	0-1-2.3	0-1-2.3	3.3
8	0-2-2.3	0-2-2.4	0-2-2.3	4.3
7				5.8
6				7.3
5				9.1
4				11.3
3				13.9
2				18.0
1				25.6

Figure 4.2. Sample Calibration Data Sheet for Overall Linearity.

## 5.0 CALIBRATION OF LOOP ANTENNAS

### 5.1 General Discussion.

The loop antenna is used to measure radiated electromagnetic fields at frequencies from a few hertz to approximately 30 MHz. The loop antenna consists of one or more turns of wire that are normally placed in an electrostatic shield surrounding the turns. The loop antenna responds to the magnetic component of the radiated field. If the relationship between the magnetic field and the electric field is known, either field can be determined in terms of the other. The two fields are related in free space by the equation

$$E = ZH, \quad (3)$$

where

$E$  = the electric field strength in volts per meter,

$Z$  = intrinsic impedance of free space,  $120 \pi$  ohms,

and

$H$  = magnetic field strength in amperes per meter.

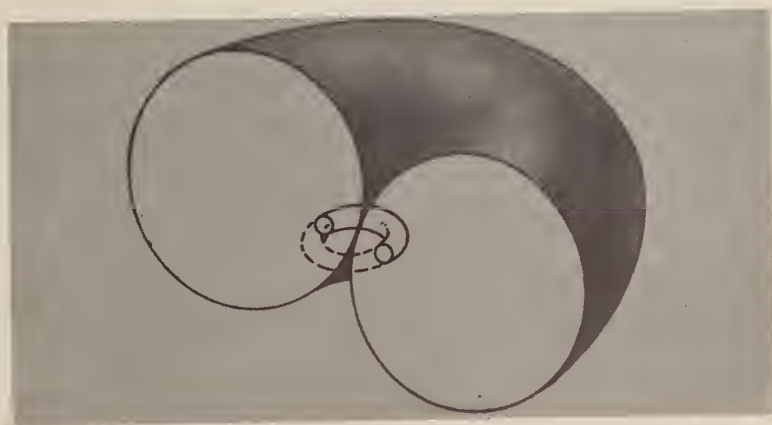

Figure 5.1. Far-field Radiation Pattern  
Loop Antennas.

The far-field radiation pattern of a loop antenna is illustrated in Figure 5.1. It is apparent that this pattern possesses certain directional properties, which are useful in direction-finding measurements. When the plane of the loop is placed in a vertical position (relative to the earth's surface), the loop is oriented for vertical polarization, and when the plane of the loop is placed in a horizontal position, the loop is oriented for horizontal polarization. It is necessary to orient the loop for maximum signal strength when measuring radiated fields. This condition exists when the axis of the loop is perpendicular to both the electric field vector and the line joining the receiver and the transmitter.

The directional properties of loop antennas are valid only if the current distribution in the loop is uniform. Loops that are large electrically, i.e., the physical dimensions are large compared to the wavelength, usually do not have a uniform current distribution. Loop symmetry is important in order to maintain a balanced output from the antenna. Stray capacities can cause unbalance in loop antennas if they are not uniformly distributed. In order to maintain symmetry and balance, and reduce other undesirable effects, a shield is usually placed around the turns of the loop. The shield must be made of a non-magnetic material such as copper or aluminum and have a small air gap at the top center of the antenna. A sketch of such a loop is illustrated in Figure 5.2.

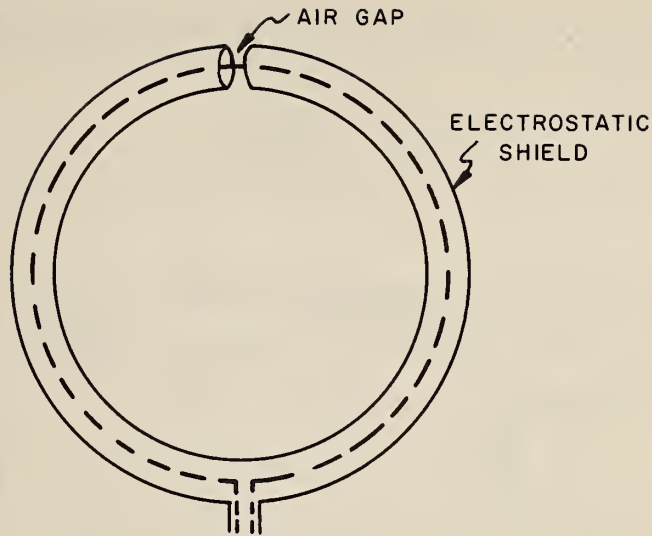

Figure 5.2. Sketch of a Loop Antenna Showing The Air Gap and Electrostatic Shield.

The effective length of an antenna can be related to field strength and induced antenna voltage by the following equation:

$$E = \frac{V_i}{l_{eff}} \quad (4)$$

where

$E$  = the electric field strength in volts per meter,

$V_i$  = the induced antenna voltage in volts,

and

$l_{eff}$  = the effective length of the antenna in meters.

By rearranging (4) to  $E (l_{eff}) = V_i$ , it is apparent that the greater the effective length of the antenna, the greater will be the induced antenna

voltage. The effective length of a loop antenna may be calculated by the following equation:

$$l_{\text{eff}} = \frac{2\pi AN}{\lambda} \quad (5)$$

where

- $l_{\text{eff}}$  = the effective length in meters,
- A = the area of the loop in square meters,
- N = the number of turns,

and

- $\lambda$  = the free-space wavelength in meters.

According to this equation, the effective length is directly proportional to the area and the number of turns. However, there are limitations that prevent excessive effective lengths. The diameter of the antenna must be electrically small ( $d \ll \lambda$ ) for equation (5) to be valid. Also, excessive number of turns can produce resonances that will seriously limit the useable frequency range of the loop. These are two of several factors that must be considered when designing and using loop antennas.

Most loop antennas used with commercial field intensity meters are designed to operate over a large frequency range such as the LP-105 loop antenna for the NF-105 FIM. The LP-105 loop is designed to operate from 0.15 to 30 MHz. Because it must work as high as 30 MHz, the natural resonance of the loop must be above 30 MHz. This loop consists of a single turn of approximately 12 inches in diameter. The effective length of such a loop is quite small.

The output of a loop is usually balanced (symmetrical with respect to ground,) and the input of most FIM's is an unbalanced 50-ohm coaxial input. The impedance of a loop antenna is not constant, but it is a function

of frequency. In order to connect a balanced loop to an unbalanced receiver, a network of some kind is required. The network design will depend on the type of loop and receiver input circuit. Several designs may be used; Figure 5.3 shows the design of three commercial FIM's.

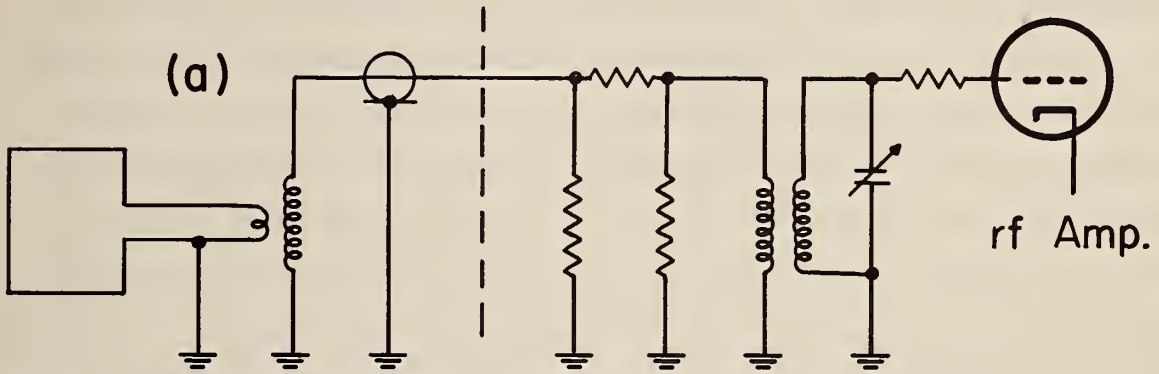

Input Circuit Of The LP-105 Loop Of The NF-105 FIM

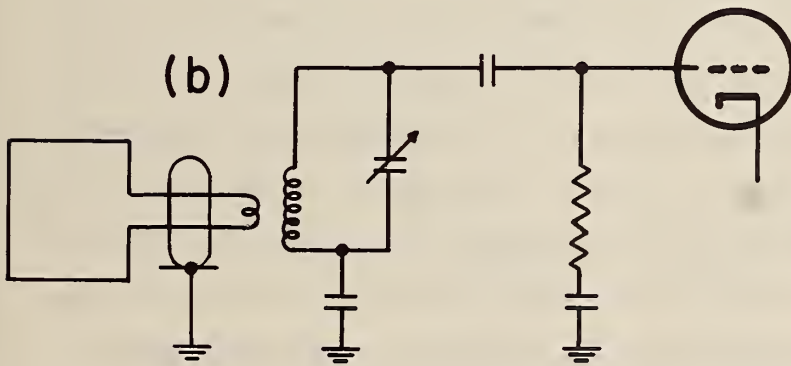

Input Circuit Of The Multi-Turn Loop Of The PRM-1 FIM

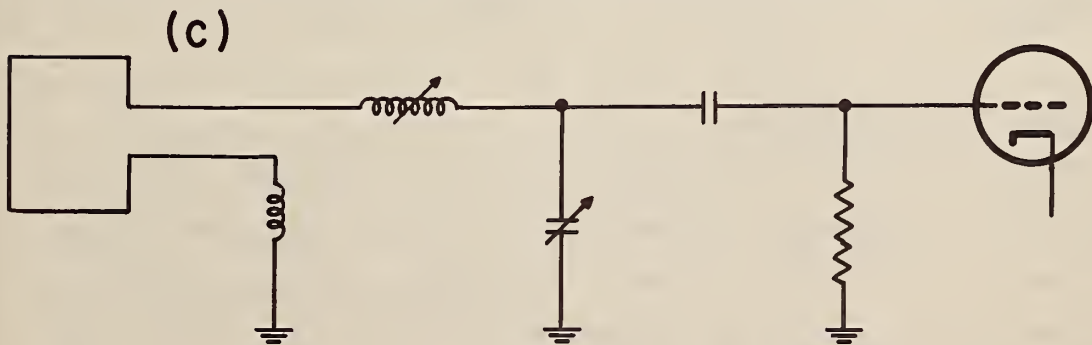

Input Circuit of the Nems-Clark 120 FIM

Figure 5.3. Different Types of Loop Antenna Input Circuits.

Figure 5.3(a) shows the input circuit of the LP-105 loop of the NF-105 FIM. The LP-105 is a single-turn shielded loop connected to the receiver by means of a 30-foot coaxial cable. Figure 5.3(b) shows the input circuit of the shielded multi-turn loop of the PRM-1. The loop is connected to the receiver by means of a very short twinax transmission line. Figure 5.3(c) is the input circuit of the Nems-Clark 120 FIM. This loop is a shielded multi-turn antenna that is made as an integral part of the FIM; therefore, it is not detachable. In general, a loop antenna and receiver that are designed to function over a large frequency range will not be as sensitive as one that is designed for a smaller frequency range. Loop resonances, excessive stray capacities, lack of symmetry, and small effective lengths are but a few of the factors that affect the design characteristics of a broadband loop antenna.

The calibration of loop antennas used with field intensity meters is necessary when measuring radiated electromagnetic fields. There are a number of techniques that can be used to calibrate loop antennas. A discussion of all calibration techniques is beyond the scope of this paper. Only selected calibration techniques will be discussed. These include the standard-field method, the standard-antenna method, and the injection method. Each technique has its advantages and disadvantages. Some methods are accurate and slow; others are less accurate but faster. Each method is discussed further in the following sections.

## 5.2 Standard-Field Method.

The standard-field method is used to calibrate loop antennas from 30 Hz to 30 MHz. Basically, this technique involves placing the antenna in a known standard field and determining a calibration factor or antenna coefficient from the magnitude of the known field and the FIM reading. The standard-field method is favored over the standard-antenna method for calibrating loop antennas, because it is more convenient, and calibrations



can be performed rapidly.

The standard-field method calibrates loops in terms of a free-space quasi-static magnetic field produced by a single-turn, unshielded, balanced transmitting loop of known radius carrying a known current. The magnitude of the field produced by a single-turn circular loop is given by the following equation [3,4,10]:

$$E = \frac{60\pi r_1^2 I}{(d^2 + r_1^2 + r_2^2)^{3/2}} \sqrt{1 + \left(\frac{2\pi d}{\lambda}\right)^2} \quad (6)$$

where

$E$  = equivalent free-space field strength in rms volts per meter,

$r_1$  = radius of the transmitting loop in meters,

$r_2$  = radius of the receiving loop in meters (if the receiving loop is rectangular, use the radius of a circle having same area).

$d$  = axial spacing in meters between the coaxial loops,

$I$  = transmitting loop current in rms amperes,

and

$\lambda$  = free-space wavelength in meters,

The actual value of the quasi-static field,  $H$ , produced by the loop is expressed in terms of the equivalent electric field,  $E$ , that would exist in a free-space radiation field by the relationship  $E = ZH$ , where  $Z$  is the impedance of free space,  $120\pi$  ohms. Equation (6) is only valid for determining the equivalent free space electric field strength, where  $r_1, r_2$ , and  $d$  are electrically small compared to  $\lambda$ . The loop spacing should be a minimum of four times the radii of the larger of  $r_1$  or  $r_2$  for (6) to be valid within one percent.

The magnitude of the field is a function of frequency (wavelength) as indicated by (6); however, the induction field component under the radical which is the frequency correction term has a negligible effect at frequencies below approximately 5 MHz. Below 5 MHz this term can be omitted without appreciable error if  $d$  is less than 2 meters. Typical loop antenna configurations are illustrated by Figure 5.4. The transmitting and receiving loops are positioned coaxially to each other at a spacing of 1 to 2 meters. The spacing is determined by the desired magnitude of the calibrating field and the frequency.

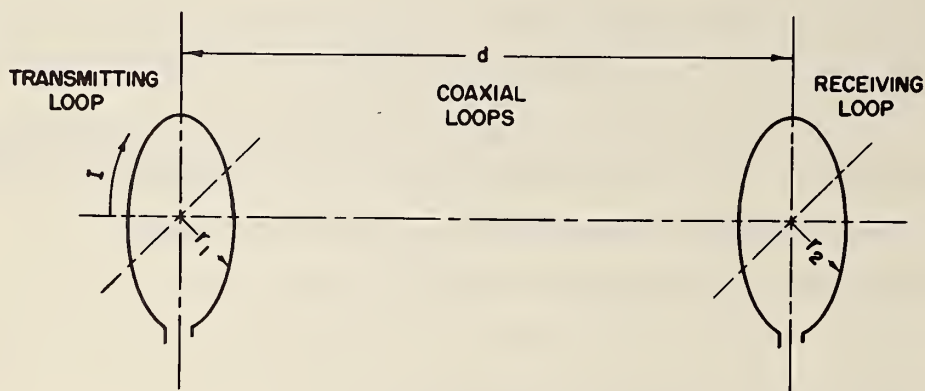

Figure 5.4. Loop Antenna Configuration For Calibration.

To meet the free-space requirements of (6), the calibration site should be in an area that is relatively free of any sizeable metallic objects that might influence or distort the calibration field. Normally, if the calibrating area is cleared of metallic objects for about two or three times the loop spacing,  $d$ , there should be no appreciable effect. The calibrating site should, therefore, be in an area relatively free of any objectionable metallic objects such as overhead power lines, shielded rooms, or steel reinforced walls. A non-metallic building with no

overhead wiring makes a satisfactory calibration site. Figure 5.5 shows a typical loop calibration setup at the NBS loop calibration site.



Figure 5.5. Typical Loop Calibration Setup at NBS.

The diameter of the NBS transmitting loop is approximately 20 centimeters, and the loop current is normally 100 milliamperes. The current is measured by means of a vacuum thermoelement mounted in the top center of the loop. This d-c calibrated thermoelement is believed to measure r-f current to well within one percent at frequencies up to 30 MHz. The output of the thermocouple is measured with a high-quality millivoltmeter or digital voltmeter. The loop input is balanced by means of a high-quality balun transformer. The term balun comes from the combination of balanced and unbalanced. The balance error of this transformer with respect to ground does not exceed 2 percent. The

uniformity of the loop current is also a function of the loop circumference. If the loop circumference is no greater than  $\lambda/16$ , the loop current will be essentially uniform. Therefore, it is apparent that the current distribution presents problems only at the higher frequencies. It may be possible to drive the loop from an unbalanced source at the lower frequencies without serious accuracy degradation.

Another point of consideration is the position of the loop antenna relative to the receiver case when the loop antenna is mounted directly to the case. The receiver case will distort the measured field, but the distortion may not be the same for the quasi-static field (calibrating field) as the radiation field. To minimize this source of error, it is advisable to specify the position of the loop relative to the receiver case if the proximity of loop is within one loop diameter of the receiver case.

### 5.3 Standard-Antenna Method.

The standard-antenna method of calibrating loop antennas has been compared with the standard-field method and good agreement between the two obtained. A standard receiving loop antenna was constructed at NBS for use at 10 MHz. It consisted of a single turn, and was approximately 20 cm in diameter, with a point contact silicon crystal diode built into the center of the loop and an R-C filter network connected at the terminals. This type of antenna [5] is illustrated in Figure 5.6.

To calibrate a loop antenna using the standard-antenna method, the calibrating field is measured first using a standard antenna. The antenna under test is then substituted in place of the standard antenna. From these data the antenna coefficients can be determined.

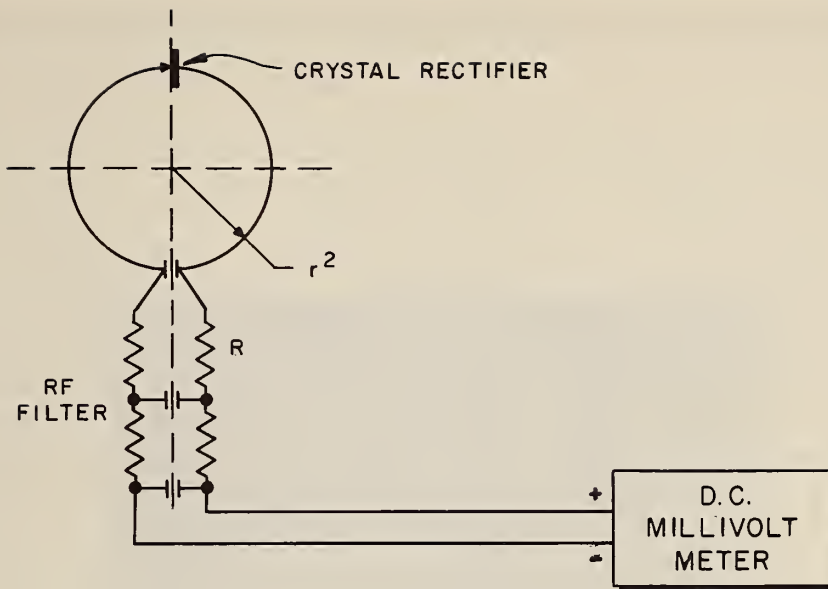

Figure 5.6. Diagram of Standard Receiving Loop Antenna.

The d-c output of the crystal is measured with a precision, high-impedance millivoltmeter and the induced antenna voltage,  $V_1$ , can be determined from the RF-DC voltage characteristics of the crystal. The magnitude of the electric field strength can be calculated from equations (4) and (5) pages 61 and 62.

A photograph of the receiving loop used at 10 MHz is shown in Figure 5.7.



Figure 5.7. Standard Receiving Loop Used at 10 MHz.

#### 5.4 Injection Method.

Another technique that can be employed to calibrate loop antennas is the injection method. A low-impedance voltage source (less than 0.1 ohm) is used to inject a known voltage in series with the loop. By calculating the effective length of the loop and knowing the injection voltage, the antenna coefficient can be determined. The chief advantage of this method is that it can be performed in the laboratory, thus the need for a special calibrating site is eliminated. There are, however, definite limitations and disadvantages to this method. It is more frequency sensitive than

some others, and the calibration results are not as accurate as others, such as the standard-field method.

Electric field strength can be related to voltage and effective length by equations (3) and (4), pages 59 and 61. The injected voltage from the low-impedance source can be substituted for the induced antenna voltage,  $V_1$ ; thus, the equivalent electric field strength can be determined in terms of the injected voltage and loop effective length.

A circuit diagram showing how the voltage can be injected in series with the loop antenna and the FIM receiver is illustrated in Figure 5.8.

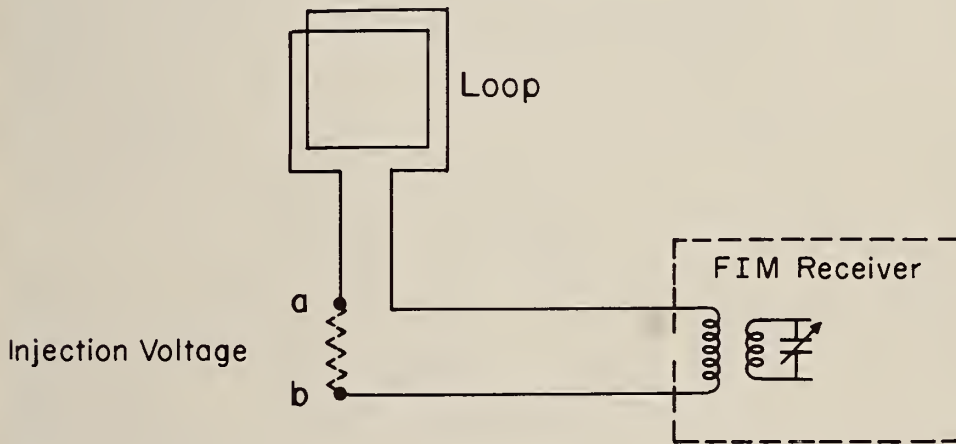

Figure 5.8. Injection Voltage Circuit Diagram.

The voltage is injected between points a and b, and should be injected without unbalancing or disturbing the loop and receiver circuits. The resistor between points a and b represents the low-impedance source used to inject the voltage. This impedance should be as low as possible.

The r-f micropotentiometer is a good voltage standard, and it has a very-low internal impedance (usually several milliohms). These properties are highly desirable in order to inject an accurate voltage into the loop without significantly disturbing the loop and receiver circuit. The resistive element of the r-f micropotentiometer serves as the resistor illustrated in Figure 5.8.

When the loop is connected to the FIM receiver by means of a balanced twin cable, an injection network is necessary to adapt the unbalanced output of the r-f micropotentiometer to the balanced terminals of the loop. When the loop is connected to the FIM receiver by means of a piece of coaxial cable such as with the NF-105 and the LP-105 loop, (balun built into the loop) it is necessary to modify the loop circuit slightly so that the voltage may be injected. The ground side of the loop is lifted and brought out of the case with an N Type coaxial connector. For normal use a shorting cap is used to complete the circuit to ground. When calibrating the loop, the shorting cap is removed and the r-f micropotentiometer is connected to the Type N connector as shown in Figure 5.9. This places the radial resistor of the r-f micropotentiometer in series with the loop as shown in Figure 5.8. Figure 5.9 shows a photograph of an NF-105 loop being calibrated using the injection method. Notice the r-f micropotentiometer being used to inject the voltage into the loop.



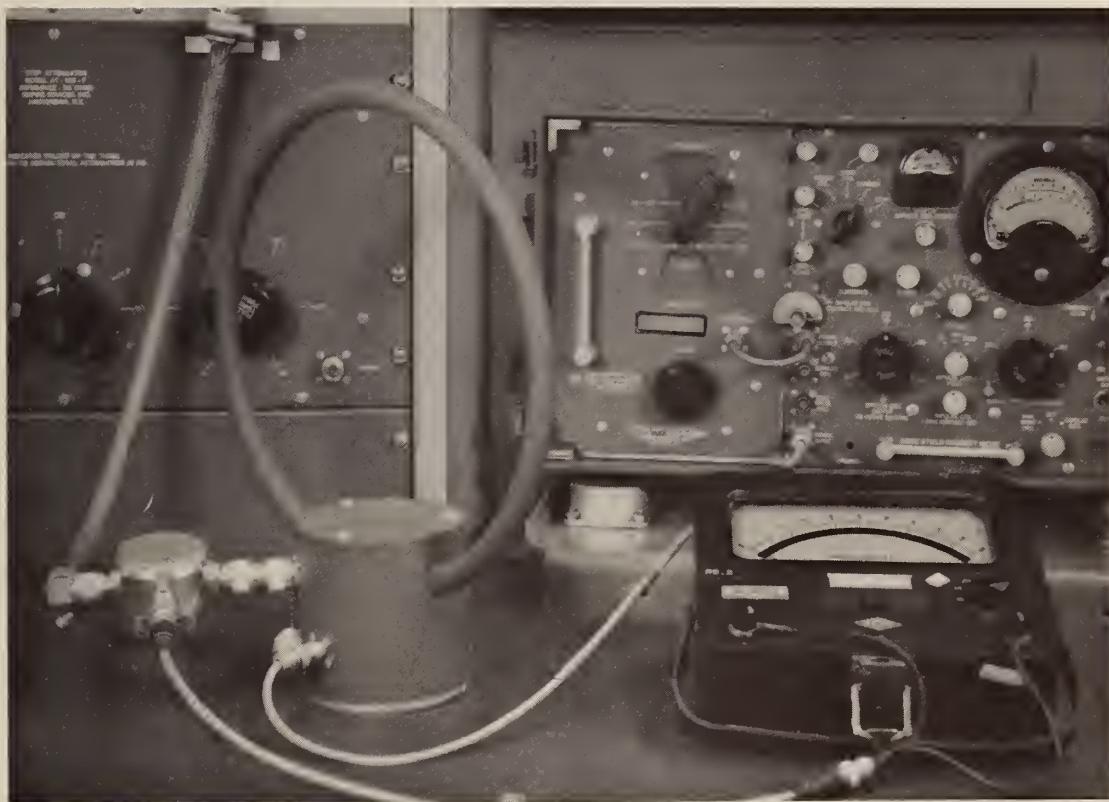

Figure 5.9. NF-105 Loop Being Calibrated Using the Injection Method

A sketch of the injection network for balanced loops is shown in Figure 5.10. The r-f micropotentiometer is used to inject the voltage using the injection network.

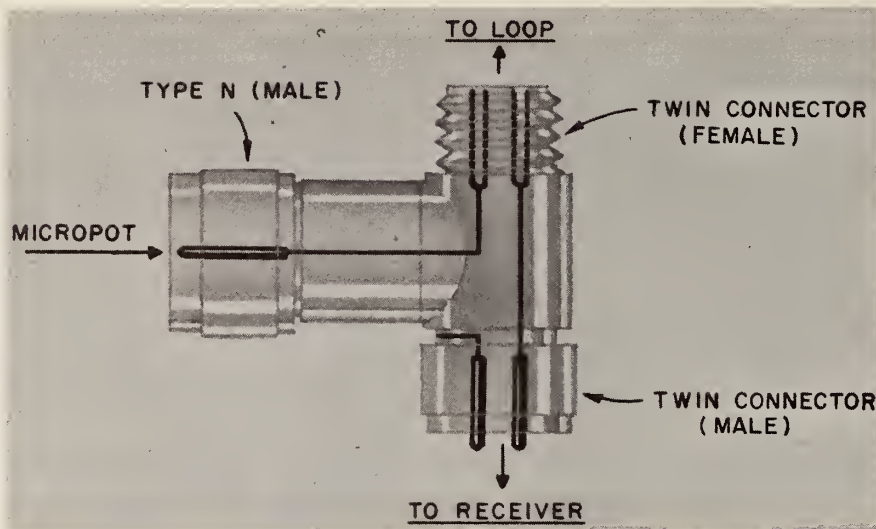

Figure 5.10. Sketch Of The Injection Network For Balanced Loops.

Injection networks designed for use with standard signal generators are commercially available. Most signal generators are not the best voltage standards; therefore, the uncertainty of the loop calibration is increased by the additional uncertainty of the signal generator which may be as much as 1 decibel or more.

The uncertainty with which loop antennas can be calibrated using the injection network varies with the design characteristics of the loop being calibrated and with frequency (the higher the frequency the greater the uncertainty). A multi-turn loop cannot be calibrated as accurately as a single-turn loop. This is due to several factors such as calculation of the effective length, stray capacities, and circuit unbalance. Comparisons

of the injection method with the standard-field method show that the injection method can be used with approximately a 10 percent measurement uncertainty at frequencies as high as 25 MHz with antennas such as the LP-105. A 10 percent measurement uncertainty is often sufficient and the time saved can make this technique quite useful.

#### 5.5 Loop Antenna Measurement Uncertainties.

The standard-field method of calibrating loop antennas is the most versatile and most accurate technique for calibrating loop antennas. It is believed that known fields can be generated to accuracies of 3 to 5 percent from 30 Hz to 30 MHz. The National Bureau of Standards offers a calibration service for loop antennas at frequencies from 30 Hz to 30 MHz with uncertainties of 3 percent at frequencies to 5 MHz and 5 percent from 5 to 30 MHz. The standard-antenna method provides a technique that is perhaps comparable in accuracy to the standard-field method except that it is limited in frequency and is very difficult to use. The injection method is a convenient technique, because it can be performed in the laboratory using readily-available laboratory equipment; but, it has certain frequency limitations as well as uncertainties of approximately 10 percent. The standard-field method offers the most accurate technique; the injection method offers the most convenient technique.

#### 5.6 Calibration Procedure for Loop Antennas (30 Hz to 30 MHz) Using the Standard-Field Method.

The standard-field method of calibrating loop antennas can be used at any frequency from 30 Hz to 30 MHz. This section of the report describes in detail the measurement setups and step-by-step procedures for calibrating loop antennas. The procedures outlined here are applicable to most types of field strength meters.

### 5.6.1 Calibration Site.

In order to meet the necessary environmental conditions for establishing standard fields, the calibration site should be in an area relatively free of any sizeable metallic objects that might influence or distort the calibration field. Normally, if the calibrating area is cleared of metallic objects within a distance of about two or three times the loop spacing, there should be no appreciable effect. The calibrating site should, therefore, be in an area relatively free of any objectionable metallic objects such as overhead power lines, shielded rooms, or steel reinforced walls. A non-metallic building with no overhead wiring makes a satisfactory calibration site.

### 5.6.2 Basic Setup.

The standard transmitting loop and the receiving loop are positioned coaxially with the planes of the two loops parallel to one another. The height of the standard transmitting loop is adjusted until the axes of both loops are at the same height. Figure 5.11 shows the loops positioned for calibration. The spacing between the loops is determined from the equation for the standard field. This distance is measured from the electrical center of the transmitting loop to the electrical center of the receiving loop. The electrical center is normally the same as the physical center. This spacing is critical and must be measured accurately.



Figure 5.11. Loops Positioned for Calibration.

A wooden table is a convenient surface to make the setup. No equipment other than the two loops should be on the table during the measurements. If the receiving loop is attached directly to the receiver, the loop and receiver must be on the table and the position of the receiver case observed. The position of the case of the receiver should be recorded in the calibration data so that the user in the field may duplicate the conditions under which the receiver and loop were calibrated.

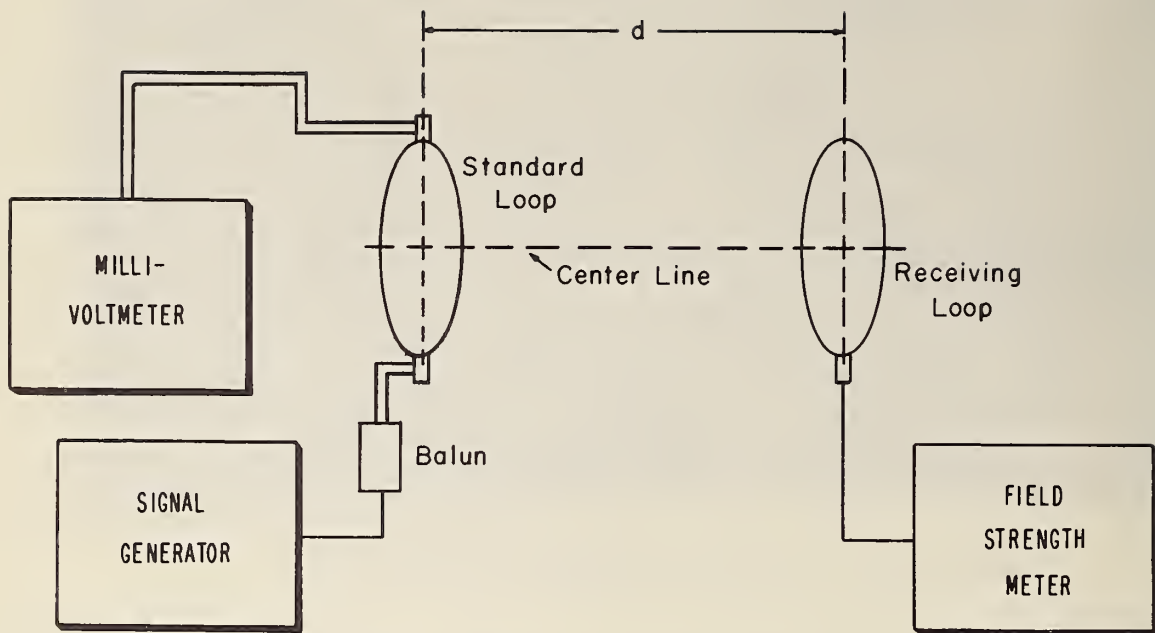

Figure 5.12. Diagram of the Measurement System for Calibrating Loop Antennas.

Figure 5.12 shows the diagram for the measurement system. The cable from the thermocouple output of the thermoelement at the top of the standard loop to the millivoltmeter is a shielded twin lead cable. The length of the RG-22 twin cable from the input of the standard loop to the balun transformer is critical. A 15-inch twin cable is generally used. If longer lengths of cable are used, a resonant condition can exist that will introduce errors into the measurements. Select the balun transformer in accordance with the calibration frequencies.

The following equipment is required to provide this calibration:

Standard Antenna Set

Signal Generator - frequency range, 30 Hz to 30 MHz -  
output, 3 volts into 50 ohms.

### 5.6.3 Calculation of the Calibration Field.

Equation (6) page 65 is used to calculate the calibrating field.

The term  $[1+(2\pi d/\lambda)^2]^{\frac{1}{2}}$  of equation (6) is the frequency correction factor; below 5 MHz it is of no significance (less than 1%) and can be omitted. The following examples show the calculation of the calibrating field below 5 MHz:

(a) If the following conditions exist,

1. Standard transmitting loop diameter = 20 cm  $\pm$  0.1 cm
2. Receiving loop diameter = 28.8  $\pm$  0.6 cm,
3. Standard transmitting loop current = 100 mA,
4. Spacing between the standard transmitting loop and the receiving loop = 1.0 m,

then

$$E = \frac{60\pi r_1^2 I}{[d^2 + r_1^2 + r_2^2]^{\frac{3}{2}}}$$

$$E = \frac{(60)(3.1416)(0.01)(0.1)}{(1.0+0.01+0.02074)^{\frac{3}{2}}}$$

$$E = 180.1 \text{ mV/m.}$$

(b) If the following conditions exist,

1. Standard transmitting loop diameter = 20 cm  $\pm$  0.1 cm
2. Receiving loop diameter = 90 cm  $\pm$  4 cm
3. Standard transmitting loop current = 100 mA
4. Spacing between standard transmitting loop and the receiving loop = 2m,

then the magnitude of the calibrating field is 21.80 mV/m.

Above 5 MHz the frequency correction of the calibrating field becomes significant (greater than 1%). The following example illustrates the significance of the frequency correction term for a calibrating field at 1.5 meters with a magnitude of 54.53 mV/m at frequencies below 5 MHz. The frequency correction term is 1.048 at 10 MHz which is approximately 5 percent.

Example: for a frequency of 10 MHz,

$$E = \frac{60\pi r_1^2 I}{[d^2 + r_1^2 + r_2^2]^{3/2}} \left[ 1 + \left( \frac{2\pi d}{\lambda} \right)^2 \right]^{\frac{1}{2}}$$

$$E = 54.53 \text{ mV/m} \left[ 1 + \left( \frac{(2)(3.1416)(1.5)}{30} \right)^2 \right]^{\frac{1}{2}}$$

$$= (54.53) (1.048)$$

$$E = 57.15 \text{ mV/m.}$$

Although the calibrating field changes for each frequency, the transmitting loop current and the spacing between loops remain the same throughout the calibration.



The table below lists the frequency correction factors and the corrected calibration fields for frequencies above 5 MHz using 54.53 mV/m as the calibrating field, and  $d = 1.5$  m.

Frequency MHz	Frequency Correction $\left[ 1 + \left( \frac{2\pi d}{\lambda} \right)^2 \right]^{1/2}$	Corrected Calibrating Field E mV/m
5.2	1.013	55.25
7.5	1.027	56.02
10.0	1.048	57.16
12.7	1.077	58.71
18.0	1.149	62.65
24.0	1.252	68.29
30.0	1.374	74.93

## 5.6.4 Calibration Procedure Using the Standard-Field Method.

### 5.6.4.1 DC Calibration of the Standard Loop Thermoelement

The following equipment is required to provide this calibration:

DC Millivoltmeter - range, 0 to 10 millivolts

Slide Wire Potentiometer - range, 100 mV -  
uncertainty  $\pm 0.1\%$  of reading.

DC Calibration Unit from the Standard Antenna Set.

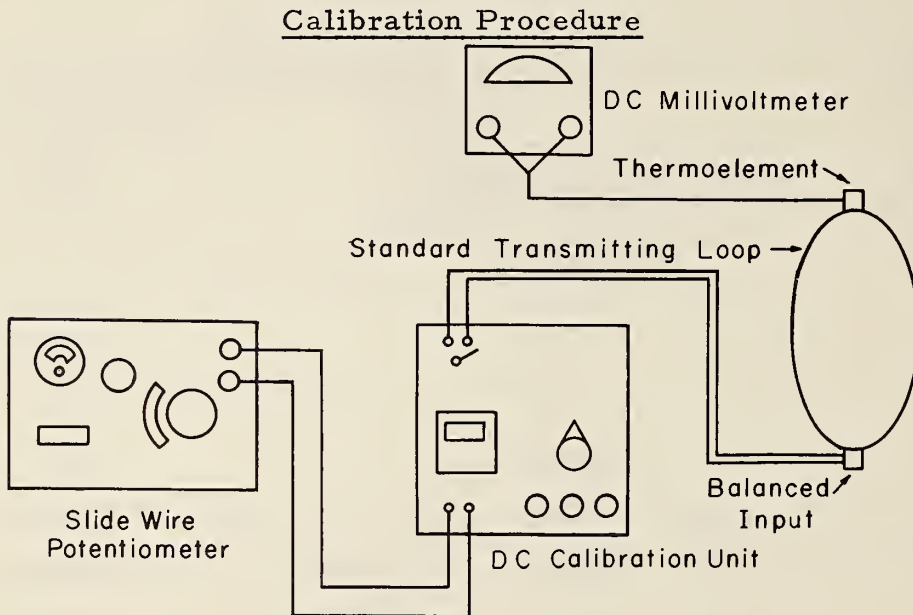

Figure 5.13. Cabling Diagram for the DC Calibration of the Standard Loop Thermoelement.

- 1) Connect the DC CALIBRATION UNIT and the DC MILLIVOLT-METER to the STANDARD LOOP as shown in Figure 5.13.
- 2) Place the DC CALIBRATION UNIT Loop Switch in the "TEST" position and then place the Function Switch in the "LOOP" position.
- 3) Adjust the d-c control knobs until the required calibrating current is read on the d-c milliammeter, (usually 100 mA).

- 4) Place the Loop Switch in the "CAL" position.
- 5) Using the SLIDE WIRE POTENTIOMETER as a milliammeter, readjust the d-c control knobs until the required calibrating current is read on the SLIDE WIRE POTENTIOMETER. (1 mV on the SWP is equal to 1 mA).
- 6) Record the thermoelement output which is indicated on the DC MILLIVOLTMETER.

#### 5.6.4.2 Calibration of the Receiving Loop Antenna.

The following equipment is required to provide this calibration:

Standard Antenna Set

DC Millivoltmeter - range, 0 - 10 millivoltmeter

Signal Generator - frequency range, 30 Hz to 30 MHz -  
output, 3 volts into 50-ohms.

#### Calibration Procedure

- 1) Connect the STANDARD TRANSMITTING LOOP and the RECEIVING LOOP and RECEIVER as shown in Figure 5.14.

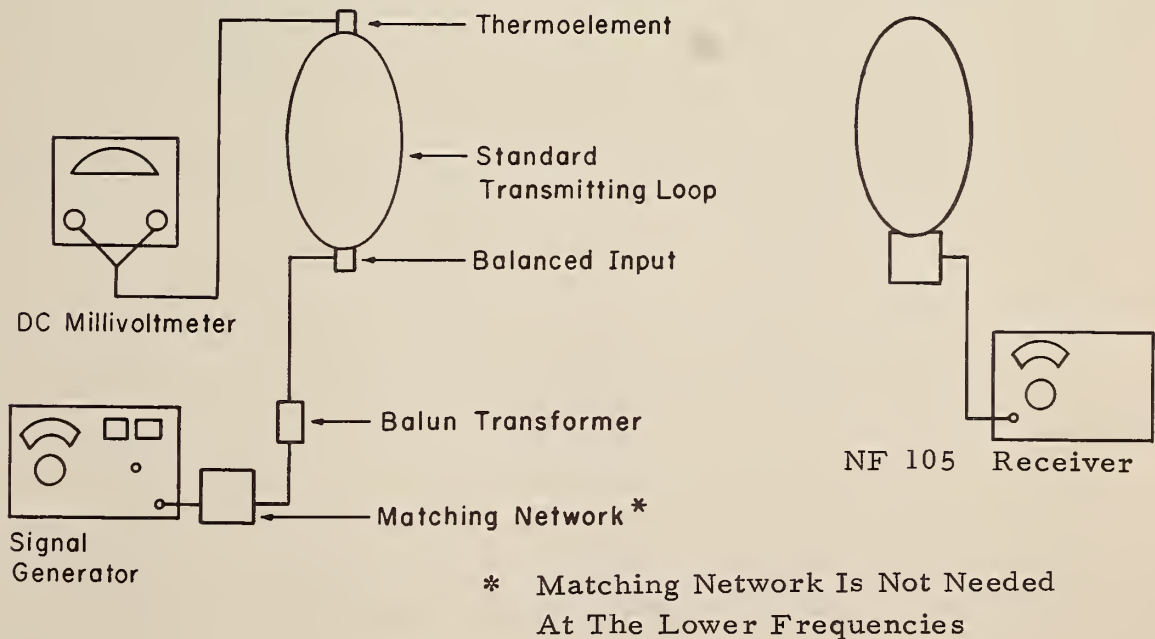

Figure 5.14. Cabling Diagram for the Calibration of the Receiving Loop Antenna.

- 2) Apply r-f to the STANDARD TRANSMITTING LOOP until the DC MILLIVOLTMETER reads just below the meter indication recorded in the d-c calibration of the thermoelement (step 6, page 83).
- 3) Tune the RECEIVER for maximum indication.
- 4) Turn off the r-f to the STANDARD TRANSMITTING LOOP. Calibrate the gain of the RECEIVER in accordance with the instruction manual.
- 5) Reapply the r-f to the STANDARD LOOP until the indication of the DC MILLIVOLTMETER is the same as the recorded indication of the d-c thermoelement calibration (step 6, page 83).
- 6) Measure the field with the RECEIVER and record the data. See Figure 5.15, page 85.
- 7) Repeat this procedure for each frequency.
- 8) The determination of the antenna factor is found in Section 7.

KIND OF MEASUREMENT Loop Antenna Calibration

INSTRUMENT TESTED NF-105 Ser. No. 1965; LP-105; TA TUNING UNIT TEST No. 920362

FREQUENCY \_\_\_\_\_ ROOM TEMPERATURE \_\_\_\_\_ °C. HUMIDITY \_\_\_\_\_ % BAROMETER \_\_\_\_\_ MM.

Gain standardized with the signal attenuator in 40 dB position

GPO : 1966 O-217-724

Std. loop current = 100 ma

Band	Freq. MHz	Loop Spacing meters	Attn. Position dB	Meter Reading			Ave. μV
				μV	μV	μV	
1	0.15	1.0	60	1.62	1.60	1.61	1.61
	0.22			1.99	1.98	1.98	1.98
	0.29			2.36	2.35	2.36	2.36
	0.36						
2	0.36			2.49	2.50	2.49	2.49
	0.50		γ	3.40	3.39	3.39	3.39
	0.65						
	0.86	γ					

Figure 5.15. Sample Data Sheet for Loop Antenna Calibration.

### 5.6.5 Uncertainties.

With proper care it is believed that known fields can be generated with uncertainties within 0.5 dB or less (approximately 6%) using the proper Set of Standard Antennas.

Several areas that are most critical to the overall performance of the measurement system are listed below:

- 1) The spacing between the loops is a critical measurement. A 1 percent error in measurement will give approximately a 3 percent error in the standard field.
- 2) The diameter of the standard transmitting loop must be known accurately. A 1 percent error in this measurement will give a 2 percent error in the standard field.
- 3) The measurement of the diameter of the receiving loop can give an appreciable error. The error is dependent upon the spacing of the loops. The greater the spacing the smaller the error. The examples given in the calculation of the calibrating field section show two calibrating fields calculated using two different spacings. The 1 meter spacing example shows a receiving loop measurement with tolerance of  $\pm 0.6$  cm while the example using 2 meter spacing shows the receiving loop measurement with a tolerance of  $\pm 4.0$  cm. Both sets of tolerances were determined using a 1 percent change in the calculated calibrating field as the limit of error.
- 4) Care also must be taken that no operator error is introduced into the operation of the FIM.

### 5.7 Calibration Procedures for Loop Antennas Using the Injection Method.

Loop antennas are usually connected to the FIM receiver by means of a twin cable (balanced input) or by means of a coaxial cable (unbalanced input). The design of the instrument determines the type of input used. The basic calibration setup for these two types of inputs is different when using the injection method. As the name implies, the injection method injects a voltage into the loop using an r-f micropotentiometer as the source of voltage. An injection network is used to inject the voltage into the balanced-input loop. The injection network is not required with an unbalanced-input loop.

### 5.7.1 Basic Setup.

The injection network is illustrated in Figure 5.10. Notice the two balanced twin connectors for connection to the loop and receiver and the unbalanced type N connector for the r-f micropotentiometer.

Figure 5.16 illustrates the injection network connected to the r-f micropotentiometer, the loop, and the receiver. The resistor,  $R$ , represents the low impedance radial resistor of the r-f micropotentiometer injecting the voltage between points  $a$  and  $b$ .

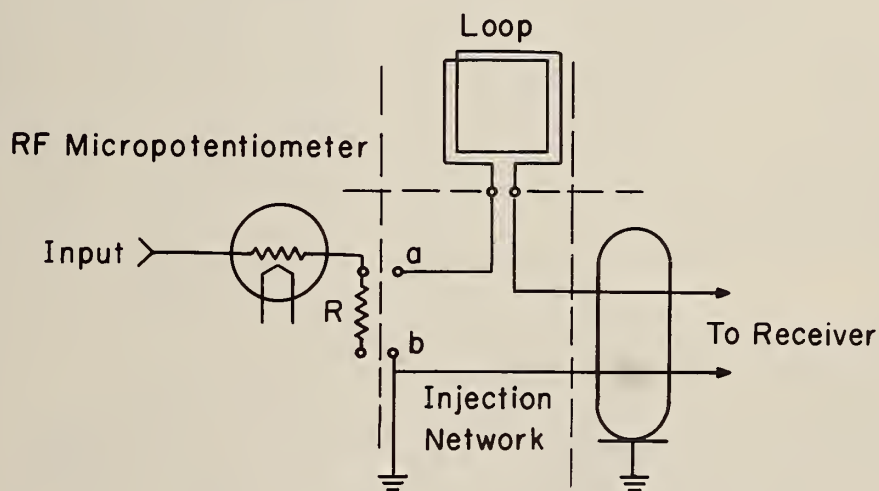

Figure 5.16. The RF Micropotentiometer Connected to a Loop With a Balanced Input Using the Injection Network.

The injection network is not used when calibrating loops with unbalanced inputs. The voltage is injected into the loop by performing a minor modification to the loop. The modification consists of disconnecting the ground side of the loop and bringing it out of the case through the center conductor of a type N receptacle. For normal use of the FIM, a type N shorting cap is placed on the receptacle to complete the ground circuit of the

loop. When calibrating the loop, the shorting cap is removed and the r-f micropotentiometer is connected to the type N receptacle. This places the r-f micropotentiometer radial resistor in series with the loop as shown in Figure 5.17.

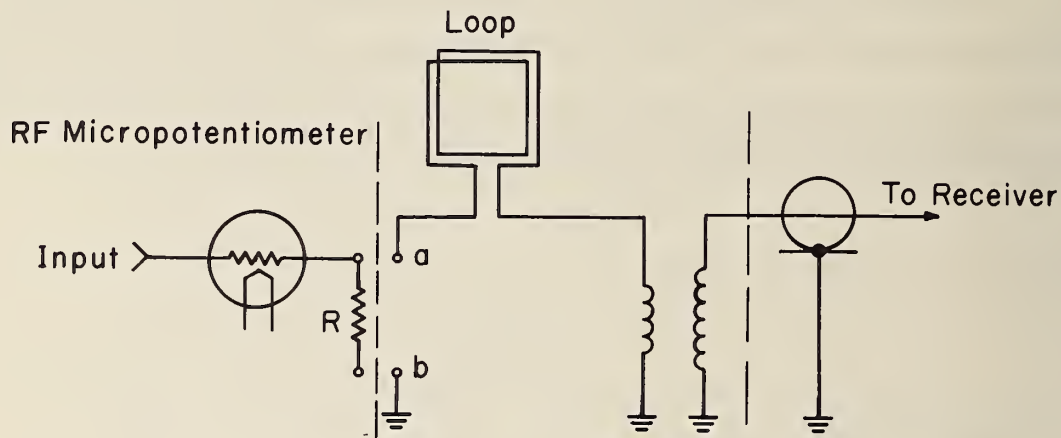

Figure 5.17. The Micropotentiometer Connected to a Loop with an Unbalanced Input.

Figure 5.18 is a photograph of an unbalanced loop being calibrated using the injection method. The r-f micropotentiometer is connected to the type N receptacle that was added in the minor modification.



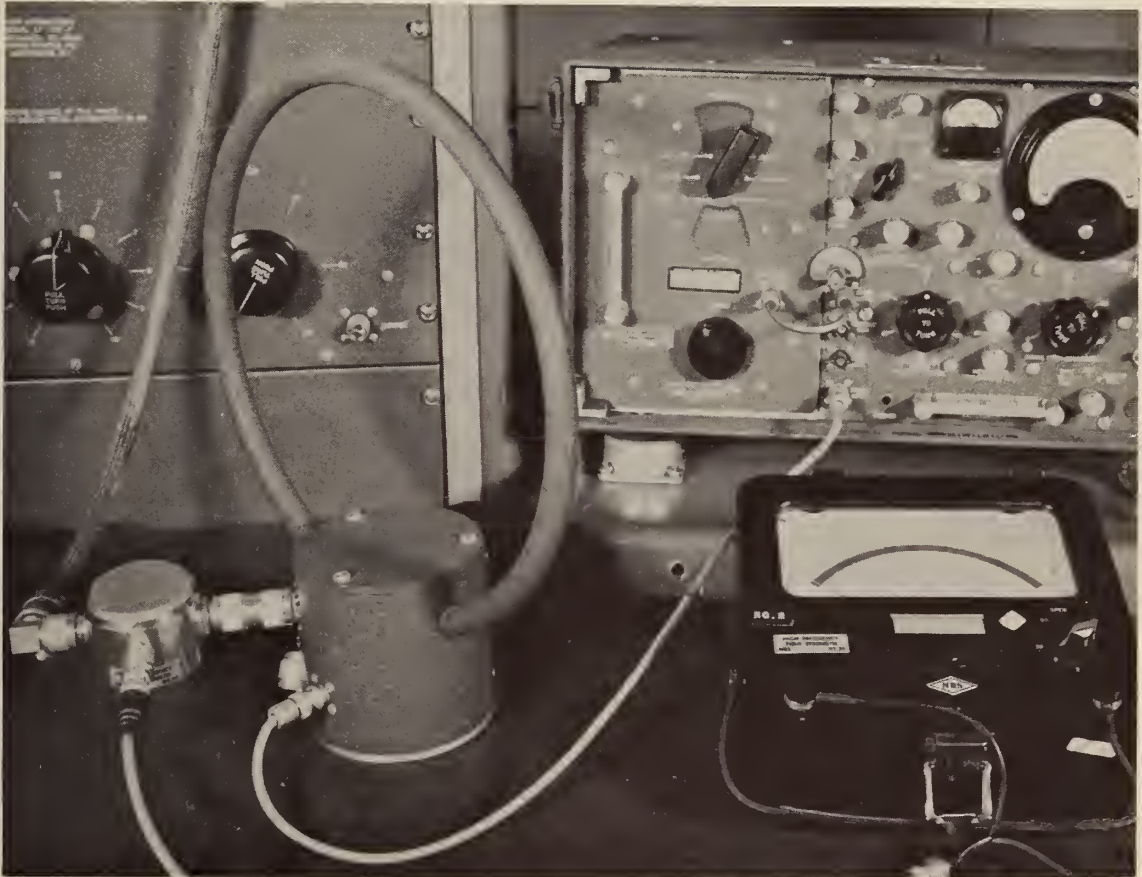

Figure 5.18. A Loop With an Unbalanced Input Being Calibrated Using the Injection Method.

### 5.7.2 Calculation of the Injection Voltage.

The injection voltage is the same as the induced antenna voltage,  $V_1$ , which is related to  $E$  and  $l_{eff}$  as follows:

$$V_1 = E (l_{eff}) \quad (7)$$

where

$V_1$  = the induced antenna voltage in volts,

$E$  = the electric field strength in rms volts per meter, and

$l_{eff}$  = the effective length of the antenna in meters as found in equation on (5) page (62).

#### Example:

Find the required injection voltage which is the same as the induced antenna voltage,  $V_1$ , equivalent to a field strength of 57.16 mV/m at 10 MHz for a one-turn loop with a radius of 14.4 cm:

$$\begin{aligned} l_{eff} &= \frac{2\pi AN}{\lambda} = \frac{2\pi^2 r^2 N}{\lambda} = \frac{(2) (3.1416)^2 (0.02074)(1)}{30} \\ &= 0.01365 \text{ meters,} \end{aligned}$$

therefore,

$$V_1 = E l_{eff} = (0.05716)(0.01365)$$

$$V_1 = 0.0007802 \text{ volts} = 780.2 \mu\text{V.}$$

The following table shows the effective length and induced antenna voltage,  $V_1$ , for a one turn loop with a radius of 14.4 cm:

<u>Frequency</u> <u>MHz</u>	$l_{eff}$ <u>millimeters</u>	$V_1$ <u>microvolts</u>	$E$ <u>millivolts per meter</u>	
0.15	0.2047	36.9	180.1	
0.22	0.3002	54.1	↓	
0.29	0.3957	71.3		
0.36	0.4913	88.5		
0.50	0.6823	123.0		
0.65	0.8870	160		
0.86	1.174	211		
1.2	1.638	295		
1.6	2.183	393		
2.1	2.866	156		54.53
3.0	4.094	223		↓
4.0	5.458	298		
5.2	7.096	392	55.24	
7.5	10.23	573	56.00	
10.0	13.65	780	57.16	
12.7	17.33	1018	58.73	
18.0	24.56	1539	62.65	
24.0	32.75	2236	68.27	

### 5.7.3 Calibration Procedure Using the Injection Method.

The following equipment is required to provide this calibration:

Signal Generator - frequency range 30 Hz to 25 MHz-  
output, 3 volts into 50 ohms,

DC Millivoltmeter - range, 0 - 10 mV

Standard Antenna Set

#### Calibration Procedure

- 1) Select the RF MICROPOTENTIOMETER that will give the desired injection voltage. Calibrate the RF MICROPOTENTIOMETER with d-c for the desired voltages.
- 2) Connect the RF MICROPOTENTIOMETER to the loop and FIM receiver - use the injection network, if required.
- 3) Apply r-f to the RF MICROPOTENTIOMETER until the desired voltage is obtained.
- 4) Tune the RECEIVER for maximum indication.
- 5) Reduce the applied r-f to its lowest level. Calibrate the gain of the RECEIVER in accordance with its instruction manual.
- 6) Reapply the r-f to the MICROPOTENTIOMETER .
- 7) Measure this voltage with the FIM and record the results on the data sheet as illustrated in Figure 5.19.

#### Determination of the Loop Antenna Factor .

The antenna factor using the injection method is determined in essentially the same manner as with the standard-field method. The magnitude of the calibrating field,  $E_s$ , is calculated using the injection voltage as  $V_1$  and equation (7).

The magnitude of the measured field,  $E_m$ , is determined from the meter readings (see Figure 5.19), and the antenna factor,  $K$ , is the ratio of  $E_s$  to  $E_m$  or

$$K = \frac{E_s}{E_m} \quad (8)$$

The data sheet in Section 7.5, Figure 7.4, illustrates how the data from Figure 5.19 can be used in calculating the antenna factor. The antenna factor can be expressed as a ratio or in decibels.

#### 5.7.4 Uncertainties.

The injection method can be used with approximately a 10 percent calibration uncertainty level at frequencies as high as 25 MHz. By calibrating the injection method in terms of the standard-field method, it may be possible to use the injection method up to 30 MHz.

U. S. DEPARTMENT OF COMMERCE  
NATIONAL BUREAU OF STANDARDS

DATE 12-12-66

SHEET NO. 1

OBSERVER JLW

KIND OF MEASUREMENT Loop Antenna Calibration

INSTRUMENT TESTED NF-105 Ser. No. 1965; LP-105; TA TUNING UNIT TEST NO. 920362

FREQUENCY \_\_\_\_\_ ROOM TEMPERATURE \_\_\_\_\_ °C. HUMIDITY \_\_\_\_\_ % BAROMETER \_\_\_\_\_ MM.

Gain standardized with the signal attenuator in 40 dB position

GPO : 1966 O-217-724

Band	Freq.	Injection Voltage	E <sub>s</sub>	Atten. Position	FIM		Ave.
					Meter Reading		
	MHz	μV	mV/m	dB	μV	μV	μV
1	0.15	36.9	180.1	60	1.62	1.60	1.61
	0.22	54.1			1.98	1.98	1.98
	0.29	71.3			2.36	2.35	2.36
	0.39	88.5					
2	0.36	88.5	↓	↓	2.49	2.49	2.49
	0.50	123.0			3.39	3.39	3.39
	0.65	160.0					
	0.86	211.0					

Figure 5.19. Sample Data Sheet for Loop Calibration.

## 6.0 CALIBRATION OF DIPOLE ANTENNAS.

### 6.1 General Discussion.

Dipole antennas are commonly used to measure the electric component of radiated electromagnetic fields at frequencies from 20 to 1000 MHz. The most popular dipole is the half-wave dipole. It is simple in construction, rugged, and possesses several desirable electrical properties that enhance its value for accurately measuring electric fields.

The far-field antenna pattern of a half-wave dipole is similar to the loop antenna pattern except that the half-wave antenna has slightly more directivity. Figure 6.1 shows the far-field antenna patterns of a half-wave dipole and a small loop antenna. The beam width between the half-power points is  $78^\circ$  on the half-wave dipole and  $90^\circ$  on the small loop antenna [6].

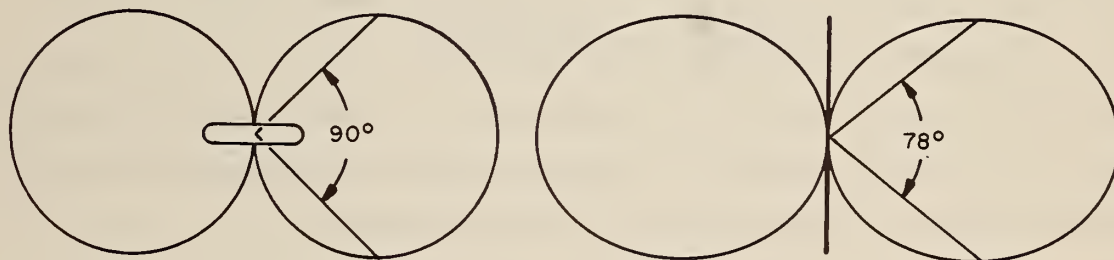

Figure 6.1. Far-Field Antenna Patterns of a Half-Wave Dipole and a Loop Antenna.

Placing a half-wave dipole antenna in a horizontal position relative to the earth's surface orients the antenna for horizontally-polarized waves, and placing the antenna in a vertical position orients it for vertical polarization.

The output terminals of a half-wave dipole are balanced with respect to ground, and when connected to an unbalanced 50-ohm FIM receiver, as is often the case, a balun transformer is necessary. The balun also can be used to match the antenna to the receiver. The impedance of a self-resonant half-wave dipole antenna is approximately 73 ohms. This value, however, is seldom applicable in most practical situations. Since it is only valid for an infinitely thin antenna in free-space, and these conditions are seldom achieved. The height of the antenna above the ground, as well as the ground constants (conductivity and dielectric constant), can significantly influence the calibration of the antenna. When calibrating dipole antennas, the height of the antenna above ground should always be specified so that the user may duplicate the height. In general, it is best to operate 0.5 wavelength or more above the ground to minimize the ground effect errors. These errors can be 10 percent or more for heights below 0.6 wavelengths. Figure 6.2 shows the computed error for a half-wavelength horizontally-polarized dipole at different wavelengths above average ground [7].



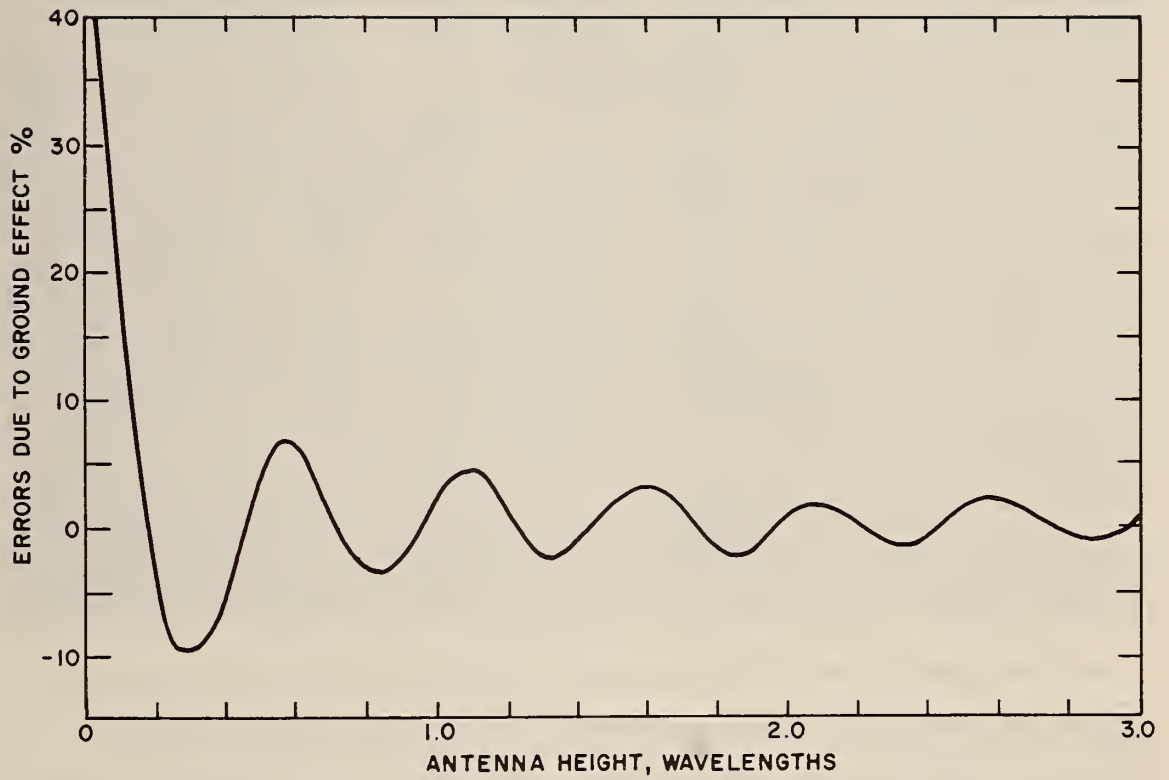

Figure 6.2. Computed Ground Effect Errors for a Half-Wavelength Horizontally-Polarized Dipole at Different Wavelengths Above Average Ground.

## 6.2 Calibrating Dipole Antennas Using the Standard-Antenna Method.

The standard-antenna method is used by the National Bureau of Standards to calibrate horizontally-polarized dipole antennas at frequencies from 30 to 1000 MHz.

The calibration is performed by radiating a horizontally-polarized field of convenient magnitude from a dipole antenna. A standard receiving antenna (capable of accurately measuring the magnitude of this field) is placed in the far-field at a fixed height above the ground, and the magnitude of the electric field is measured. The transmitting antenna power is held at a constant level, and the antenna being calibrated is substituted in place of the standard-antenna. The antenna factor is then determined by equation (8), page 92.

The NBS standard receiving antenna consists of a self-resonant, half-wave dipole antenna with a high impedance balanced voltmeter built into the center of the antenna. The balanced voltmeter is composed of a selected point-contact silicon crystal diode as the detector and an R-C filter network. The d-c output of the crystal can be measured with any high quality high impedance millivoltmeter. Figure 6.3 is a photograph of an experimental standard receiving dipole antenna showing the silicon crystal diode and the R-C filter network. This particular antenna is used at frequencies from 400 to 1000 MHz. The antenna mount is made of PTFE\* and the antenna rods are 1/16-inch diameter silver plated brass. The ends of the antenna rod are threaded internally so that extensions may be added to change the operating frequency of the self-resonant dipole.

\* Polytetrafluorethylene

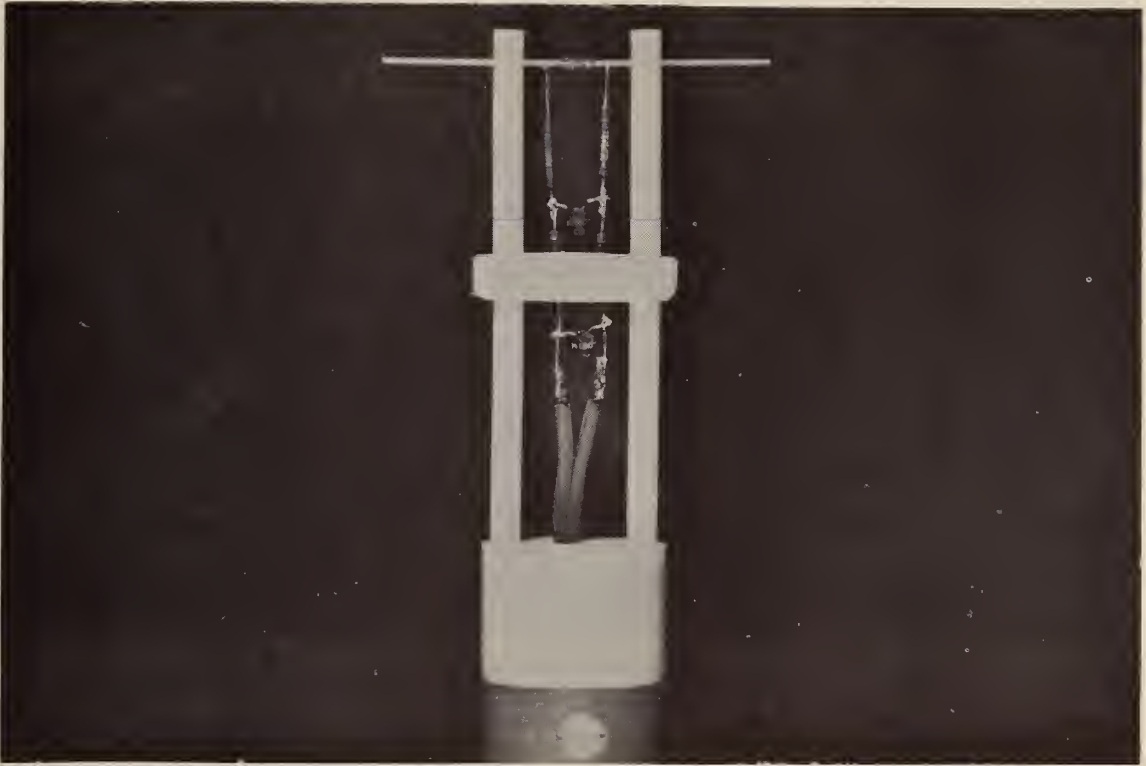

Figure 6.3. Experimental Crystal-Diode Receiving Dipole.

The crystal diodes are carefully selected to optimize characteristics such as frequency insensitivity, temperature stability, voltage sensitivity, r-f impedance, and shunt capacity. Several types have been evaluated. For the lower frequencies (30 to 400 MHz) a ceramic cartridge type diode is used; for the higher frequencies (400 to 1000 MHz) a glass encapsulated, subminiature diode is often used.

The frequency response of each crystal diode is evaluated using the basic setup illustrated in Figure 6.4. The bolometer and power meter are carefully calibrated so that a constant power level may be applied to the diode mount. The bolometer is also the 50-ohm termination for the system. The 20-dB pad serves as an isolator. The low pass filter is used to minimize errors that might be attributed to

generator harmonics, and the d-c output of the crystal diode is measured with an accurate potentiometer or other high impedance millivoltmeter.

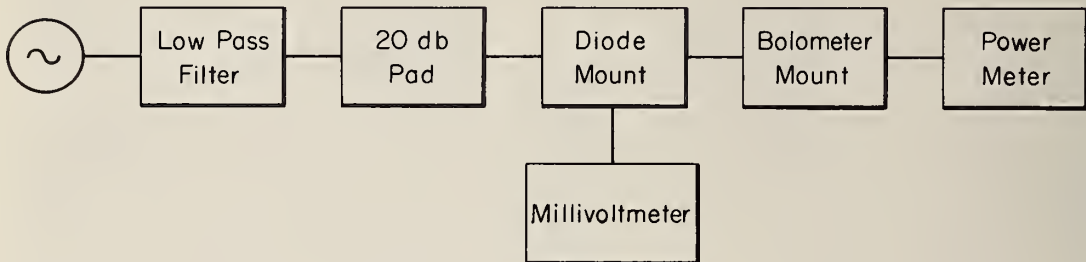

Figure 6.4. Measurement System for Evaluating the Frequency Response of Crystal Diodes.

The diode mount is made from a Type N T-connector as illustrated in Figure 6.5. A cutaway on the left shows how a ceramic cartridge diode is positioned in the mount. The dielectric material supporting the center conductor is PTFE. The d-c output of the crystal is filtered by approximately 100 picofarads formed by the T-connector body and the cylindrical mass on the diode output. Two-mil PTFE tape was used to form the dielectric of this capacitor. The VSWR of this mount is less than 1.05 up to 1000 MHz. The diode is removed from the mount by removal of the PTFE-covered cylindrical mass on the diode output. When the subminiature glass diodes are placed in the mount, small adapters are placed on each end.

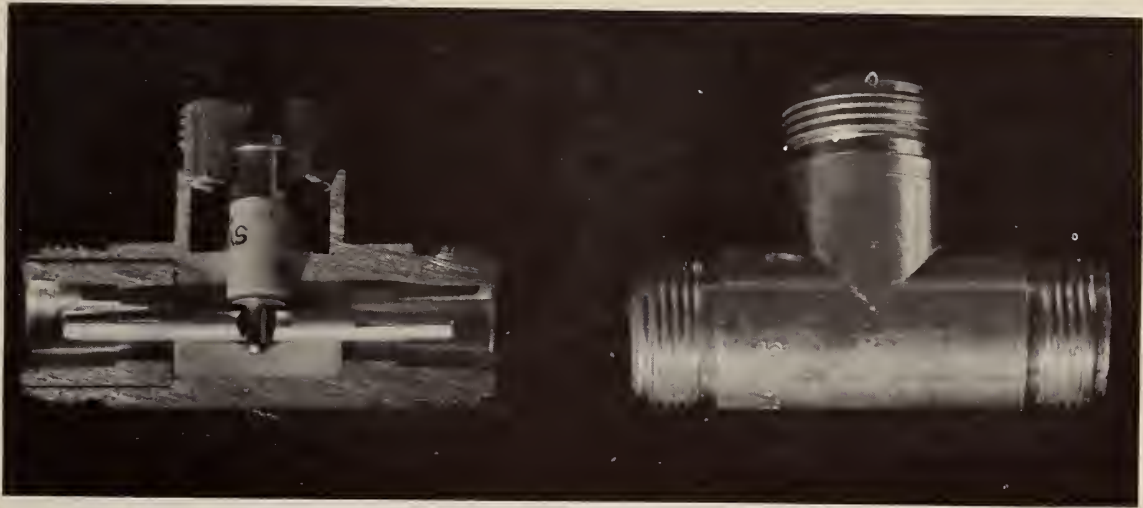

Figure 6.5. Cutaway of Diode Mount Used for Evaluating Frequency Response.

The frequency response of two types of diodes is plotted in Figure 6.6. The power level applied to the diodes was held constant and the d-c output of the diode plotted as a function of frequency. These two curves represent only the frequency response of selected diodes and are not typical of all diodes of these types. The response of the ceramic diode is flat to approximately 500 MHz and physically adapts very well to the lower frequencies (30 to 400 MHz). The glass diode is flat to approximately 800 MHz and has approximately 3 to 4 percent frequency correction at 1000 MHz. This type is more suitable for the higher frequencies (400 to 1000 MHz). Both the ceramic and glass diodes have been used up to 1000 MHz, but the frequency correction of the ceramic diode is considerably higher at 1000 MHz, and it does not possess the physical qualities of the smaller glass diode. The frequency response of both mixer and video detectors have been evaluated, and there does not appear to be any significant difference between the two in this particular application.

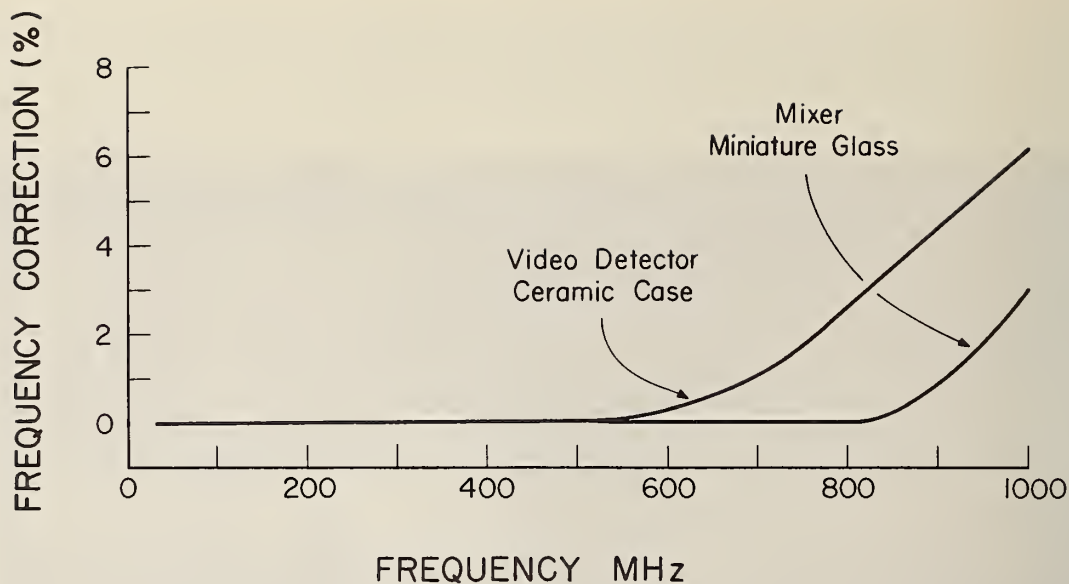

Figure 6.6. Frequency Response Curves of Selected Crystal Diodes.

The temperature coefficients of these diodes are not uniform. The majority of those tested have a decreasing d-c output with increasing temperature, but some have been tested that are just the opposite. In order to reduce errors due to temperature changes the diodes are calibrated as a balanced r-f voltmeter at a temperature as close as possible to that at which they are used. Temperature corrections can be applied if necessary.

The crystal-diodes are calibrated as a balanced r-f voltmeter by applying a known balanced voltage to the diode and measuring its d-c output. This is illustrated in Figure 6.7. The balanced voltage standard is attached to the diode mounted in the antenna by means of gold plated clips. The d-c output of the diode is measured with a potentiometer. The voltage standard is used at 50 MHz and has an output of 150 millivolts. The output of the voltage standard is controlled by changing the input voltage

in known amounts by means of a precision step-attenuator. The 50-MHz, 150 mV output of the balanced voltage standard has been referenced to an NBS unbalanced voltage standard and is believed to have an uncertainty of 1 or 2 percent.



Figure 6.7. Balanced Voltage Standard Attached to Crystal Diode Mounted in Antenna.

The electric component of a field can be expressed in terms of the induced antenna voltage and the effective length of the antenna,  $l_{eff}$ . The effective length of a half-wave dipole (assuming sinusoidal current distribution) can be calculated from the relationship

$$l_{eff} = \frac{\lambda}{\pi} \tan \frac{\pi l}{\lambda}, \quad (9)$$

where  $l$  is the antenna half-length in meters. The induced antenna voltage is measured with a reasonably high impedance balanced voltmeter; therefore, the loading effect on the antenna is negligible and its terminal voltage is essentially the same as the open-circuit voltage (referred to the center terminals). The magnitude of the field can be determined by the relationship

$$E = \frac{V_{oc}}{l_{eff}}, \quad (10)$$

where

$E$  = electric field strength in volts per meter,

$V_{oc}$  = open-circuit antenna voltage in volts, and

$l_{eff}$  = effective antenna length in meters.

In order to achieve a self-resonant, half-wave, dipole antenna of finite thickness, it is necessary to shorten the overall length of the antenna. The shortening is a function of the antenna rod diameter and frequency. The percent shortening may be determined by the following equation [8]:

$$\% \text{ shortening} = \frac{2708}{K_0}, \quad (11)$$

where

$K_0 = 120 \left[ \log_0 \left( \frac{\lambda}{d} \right) - 1 \right]$ , and

$d$  = antenna rod diameter in centimeters.

The percent shortening of the NBS antennas is usually between 4 and 6 percent, depending on the length to diameter ratio. The transmitting antenna is also a self-resonant, half-wave antenna identical in physical dimensions to the receiving antenna. The transmitting antenna is fed with a balanced input by means of a balun transformer.



The antenna measurements are performed at a nearby calibration site. A picture of this site is shown in Figure 6.8. The power lines are buried underground, and all sizeable metallic objects are minimized.



Figure 6.8. Antenna Calibration Site.

The transmitting and receiving antennas are spaced a minimum of 3 wavelengths apart. The distance is usually 100 feet at frequencies from 30 to 400 MHz and 40 feet at frequencies from 400 to 1000 MHz. The calibrating equipment is housed in a console in the larger building. Buried coaxial cables connect the r-f power sources to the transmitting antennas. Figure 6.9 is a picture of the NBS calibration setup for a dipole antenna. The standard receiving antenna is mounted in the foreground, and the transmitting antenna is mounted in the background. The field strength receiver and its antenna (laying on the ground) are near the

operator. The field strength meter antenna is substituted in place of the standard antenna after the strength of the calibrating field is determined. Antennas submitted for calibration are normally calibrated at a height of 10 feet or more above the ground, because the presence of the ground will have an effect on the antenna impedance and thus an effect on the antenna factor. If used at lower heights it is advisable to use additional corrections [7].

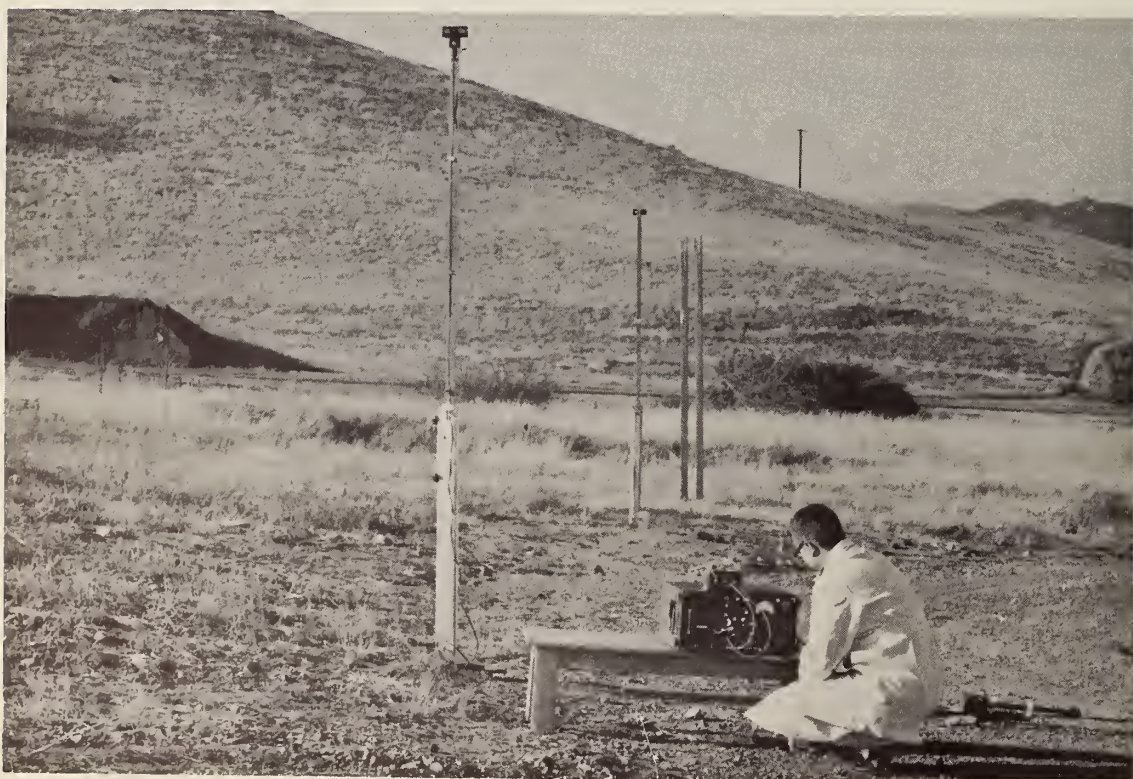

Figure 6.9. Typical NBS Dipole Antenna Calibration Setup.

### 6.3 Other Methods of Calibrating Dipole Antennas.

Another method of calibrating dipole antennas is the standard-field method where the field is determined in terms of the transmitting antenna parameters, incident and reflected signals, and the field site characteristics. This technique requires more knowledge of the surrounding environment and is more difficult and time-consuming than the standard-antenna method. This method is used at NBS to compare antenna calibration techniques [9].

A modification of the standard-antenna method has been used for experimentation purposes and compared with the standard-antenna method. The current in a receiving antenna is measured using a thermoelement, and the electric field strength is determined in terms of antenna current, dipole impedance, and dipole effective length. Double expanded styrofoam was used to support the self-resonant dipole constructed of 28-gauge wire. The small diameter wire more nearly approaches the ideal antenna. The thermoelement heater serves as a low impedance load for the antenna.

The desired open-circuit antenna voltage may be determined by the following relationship:

$$V_{oc} = \left| \frac{V_L (Z_A + Z_L)}{Z_L} \right| \quad (12)$$

where

$V_L$  = load voltage,

$V_{oc}$  = open-circuit voltage,

$Z_L$  = load impedance, and

$Z_A$  = antenna input impedance.

This technique has certain inherent disadvantages and is difficult to accomplish. It was compared with the standard-antenna method at frequencies to 500 MHz with agreement to within 5 percent [5].

A calibration can be performed by calibrating the antennas in terms of receiver accuracy as a two-terminal r-f voltmeter, antenna balun transformer characteristics, and the assumption that the antenna is ideal. This method is easy to perform because the measurements can be performed in the laboratory, but the results are not very encouraging. Agreement with the standard-antenna method was no better than 15 to 25 percent at some of the higher frequencies.

#### 6.4 Dipole Antenna Measurement Uncertainties.

The standard-antenna method of calibrating dipole antennas has been compared with the standard-field method at selected frequencies up to 1000 MHz in order to determine the uncertainty. The agreement between the two methods varied from 5 percent at the lower frequencies [4] to 10 percent at the higher frequencies. The establishment of accurately-known standard-fields at the frequencies within this range is difficult and requires a large flat area (several acres) without interfering objects such as trees or power lines. This type of location is often not readily available nearby. The standard-antenna method of calibrating dipole antennas is easier to perform, and the calibrating site requirements are less stringent.

Other techniques that have been investigated and compared with the above-mentioned techniques include the measurement of the receiving antenna current, and the determination of the electric field strength in terms of the antenna current, dipole impedance, load impedance, and effective length. Thermoelements are used to measure the antenna current.

The measurements using this technique are in reasonably good agreement with the standard-antenna method, but the technique has certain inherent disadvantages, and is somewhat difficult to accomplish.

It is believed that dipole antennas can be calibrated to within a measurement uncertainty of 12 percent or 1 decibel (using the standard-antenna method). Horizontal polarization is recommended for this calibration, although it is believed to be essentially the same for vertical polarization.

6.5 Calibration Procedure for Dipole Antennas (30-1000 MHz) Using the Standard-Antenna Method.

This section of the report describes the measurement setups and step-by-step procedure for calibrating half-wave horizontally-polarized dipole antennas at frequencies from 30 to 1000 MHz. The following frequencies are those generally used for the calibration of dipole antennas:

Frequency  
MHz

30  
35  
50  
65  
100  
  
150  
200  
250  
300  
400  
  
500  
600  
700  
800  
900  
1000

The system can be used at other frequencies between 30 and 1000 MHz, but it is necessary to make the antenna rods for each frequency selected.

### 6.5.1 Calibration Site.

The selection of a calibration site is important, because a poor calibration site can introduce considerable errors in the measurements. The ideal calibration site is a flat open area containing underground power lines and cleared of all obstructions for at least 300 feet in all directions. The ideal site is not often available and it is necessary to select a site that as nearly approaches the ideal site as possible. Avoid large metallic structures that might distort the calibrating field or change the antenna characteristics. Non-metallic buildings can be tolerated in the calibrating vicinity without undue deterioration of the calibrating field. Figure 6.10 shows a calibration site for dipole antennas that has non-metallic structures in the calibrating area. This site has proved to be satisfactory. When calibrating dipole antennas, REMEMBER, you are trying to calibrate the antenna under as nearly the same conditions as the



Figure 6.10. Calibration Site for Dipole Antennas.

antenna will be used in the field. A calibration that is valid for only one set of measurement conditions is not desirable for general field use.

#### 6.5.2 Basic Setup.

The Set of Standard Antennas contains two sets of transmitting and receiving antennas. One set of dipoles is used to calibrate from 30 to 300 MHz; these are called the low-frequency dipoles. The other set, called the high-frequency dipoles, is used to calibrate from 300 to 1000 MHz.

Figure 6.11 shows a diagram of a basic calibration setup. Both the transmitting and receiving antennas are placed at the height ( $h$ ) of 10 feet above the ground with the rods of the dipoles parallel to each other. The spacing ( $d$ ) between the two antennas is not critical but should be a minimum of 2 to 3 wavelengths. A convenient spacing is 100 feet for frequencies from 30 to 300 MHz and 30 to 40 feet at frequencies from 300 to 1000 MHz.



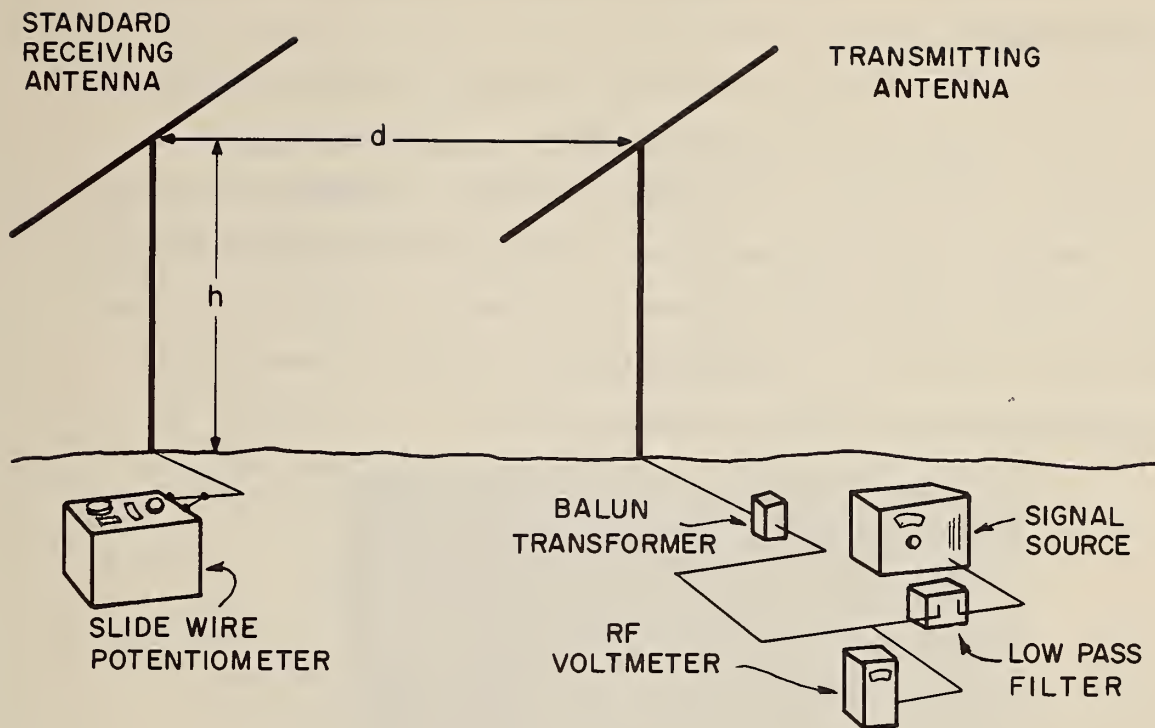

Figure 6.11. Diagram of Basic Calibration Setup for Dipole Antennas.

The transmitting antenna is connected to a signal generator through a low-pass filter and a balun transformer. The low-pass filter reduces the harmonics from the signal generator. A low-pass filter may not be required if the generator harmonics are 40 decibels below the fundamental. The balun transformer is used to connect the unbalanced signal generator to the balanced transmitting antenna. The r-f voltmeter is used to monitor the output of the signal generator.

The output from the standard receiving antenna is connected to the slide wire potentiometer. The twin-lead cable is brought straight

down the antenna mast to the ground and across the ground to the slide wire potentiometer.

The unknown receiving antenna is mounted to a mast so that it will be at the same height above the ground, when placed in position for measurement, as the standard receiving antenna. The unknown antenna must be mounted so that when substituted in place of the standard antenna the distance to the transmitting antenna is the same. A large error can be introduced if the unknown receiving antenna is not positioned in the same position as the standard receiving antenna.



Figure 6.12. Typical Field Calibration Setup for Dipole Antennas.

Figure 6.12 shows a photograph of a calibration setup under normal field conditions. The transmitting antenna and the standard receiving antenna are shown. Some liberty has been taken in the spacing between the two antennas so that more detail can be shown in this photograph.

### 6.5.3 Calibration of the Voltage Standard.

The following equipment is required to provide this calibration:

DC Millivoltmeter - range 0 to 10 mV

Slide Wire Potentiometer - range, 0 to 150 mV  
uncertainty  $\pm 0.1\%$  of reading,

Standard Antenna Set

#### Calibration Procedure.

- 1) Select the proper voltage standard; the low-frequency dipole uses one voltage standard; the high-frequency dipole uses another.
- 2) Turn the Function Switch of the DC CALIBRATION UNIT to the "OFF" position.
- 3) Connect the equipment as shown in Figure 6.13 (a). The high-frequency dipole voltage standard (300 to 1000 MHz) is connected directly to the DC CALIBRATION UNIT as shown in Figure 6.13 (b). The LOW-FREQUENCY DIPOLE VOLTAGE STANDARD (30 to 300 MHz) is connected to the DC CALIBRATION UNIT by means of a 6-foot twin cable and a female-to-female adapter (in lid of the DC Calibration Unit).
- 4) Turn the Function Switch of the DC CALIBRATION UNIT to the "DIPOLE VOLTAGE STD" position and the "DIPOLE VOLTAGE STD." switch to the "CAL" position.
- 5) Increase the d-c output of the DC CALIBRATION UNIT until the SLIDE WIRE POTENTIOMETER reads 150 millivolts.
- 6) Record the thermocouple output on the DC MILLIVOLTMETER. This setting represents the 150 mV output of the voltage standard.

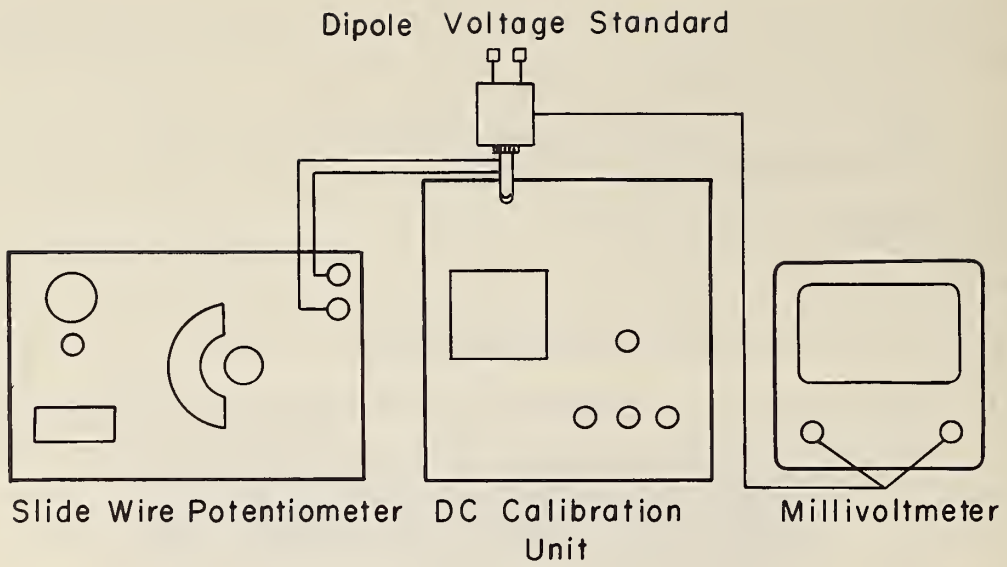

Figure 6.13(a). Diagram Showing the DC Calibration of the Dipole Voltage Standard.



Figure 6.13(b). Photograph Showing the DC Calibration of the Dipole Voltage Standard.

#### 6.5.4. Calibration of the Antenna Crystal Diode.

The following equipment is required to provide this calibration:

Signal Generator - frequency range 50 MHz -  
output, 2 volts into 50-ohms,

Slide Wire Potentiometer - range, 0 to 150 mV  
uncertainty  $\pm 0.1\%$  of reading,

Step Attenuator - 60 dB maximum attenuation with  
0.1 dB steps,

DC Millivoltmeter - range 0 - 10 mV

#### Calibration Procedure

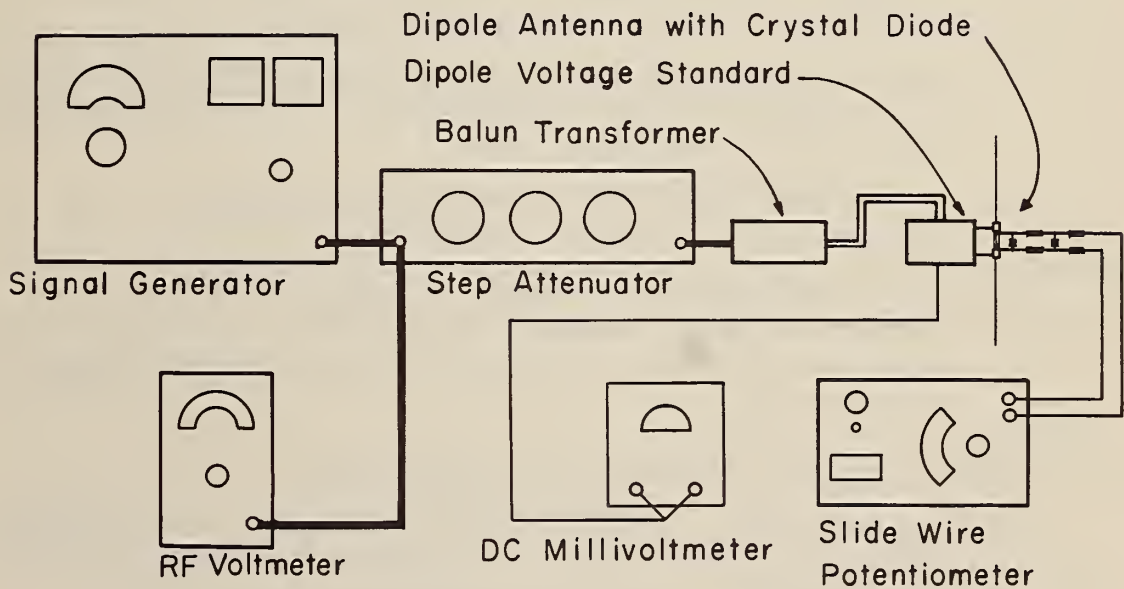

Figure 6.14. Diagram of Antenna Crystal Diode Calibration Setup.

- 1) Connect the setup as shown in Figure 6.14, page 117.
- 2) Set the frequency of the SIGNAL GENERATOR to 50 MHz.
- 3) With the STEP ATTENUATOR in the zero position, apply r-f until the thermocouple output reads the same as noted in step 6 on page 115.
- 4) Note the reading of the RF VOLTMETER. This reading will be used throughout the calibration to maintain a constant r-f level.
- 5) Measure the d-c output from the crystal diode with the SLIDE WIRE POTENTIOMETER. Record the measurement as shown in Figure 6.15.
- 6) Add 3 dB of attenuation to the STEP ATTENUATOR. Readjust the SIGNAL GENERATOR output so that the RF VOLT-METER reads the same as noted in step 4.
- 7) Again, measure the d-c output from the crystal diode with the SLIDE WIRE POTENTIOMETER. Record the measurement as shown in Figure 6.15.
- 8) Steps 6 and 7 are repeated until the d-c output from the crystal diode is less than 5 millivolts.
- 9) Figure 6.16 shows an example of how the data from Figure 6.15 can be plotted. It shows the r-f voltage applied to the crystal diode plotted against the d-c output of the crystal.

#### 6.5.5 Calibration of the Unknown Receiving Antenna.

- 1) The rods of the TRANSMITTING ANTENNA, the STANDARD RECEIVING ANTENNA, and the unknown receiving antenna are adjusted in length for the calibration frequency.
- 2) Set up the equipment in accordance with the Basic Setup, page 112 and Figure 6.11.
- 3) Apply r-f to the TRANSMITTING ANTENNA.
- 4) The STANDARD RECEIVING ANTENNA is placed in position, and the field measured. The output of the SLIDE WIRE POTENTIOMETER is recorded. See sample data sheet Figure 6.17.

- 5) The unknown receiving antenna is now substituted in place of the STANDARD ANTENNA, and the field strength is measured with the Field Strength Meter. Record the measurement as shown in Figure 6.18.
- 6) Steps 4 and 5 are usually repeated three times. The RF VOLTMETER is used to monitor the level of the generator during the measurement.
- 7) The same procedure is repeated for each calibration frequency.
- 8) The determination of antenna factors is found in Section 7.

#### 6.5.6 Uncertainties

Dipole antenna calibrations uncertainties can be performed within 12 percent or 1 decibel using the standard-antenna method.

#### Precautions to observe during measurements.

1) The standard receiving antenna and the unknown receiving antenna should be mounted so that when positioned they are at the same height and spacings.

2) If possible, avoid calibrating during large temperature variations. The crystal diodes are temperature sensitive and if calibrated at one temperature and used at a much different temperature, errors will be introduced. It is advisable to calibrate the crystal diode at nearly the same temperature as it will be used.

3) A constant monitor of the power to the transmitting antenna is recommended during calibration to avoid errors because of undesirable level changes.

U. S. DEPARTMENT OF COMMERCE  
NATIONAL BUREAU OF STANDARDS

DATE 12-12-66

SHEET No. 7

OBSERVER JEC

KIND OF MEASUREMENT Crystal Diode Calibration

INSTRUMENT TESTED Xtal 1N832A TEST No. 920367

FREQUENCY 50 MHz ROOM TEMPERATURE \_\_\_\_\_ °C. HUMIDITY \_\_\_\_\_ % BAROMETER \_\_\_\_\_ MM.

GPO : 1966 O-217-724

Crystal		Output		Atten.	RF		
			Ave			Input	
mV-dc	mV-dc	mV-dc	mV-dc	dB	mV-rf		
139.1	139.2	139.1	139.1	0	150.0		
87.5	87.6	87.7	87.6	3	106.2		
53.3	53.3	53.3	53.3	6	75.2		
31.1	31.0	31.1	31.1	9	53.2		
17.3	17.3	17.3	17.3	12	37.7		
9.0	9.1	9.1	9.1	15	26.7		
4.6	4.6	4.6	4.6	18	18.9		

Figure 6.15. Sample Data Sheet for Crystal Diode Calibration.



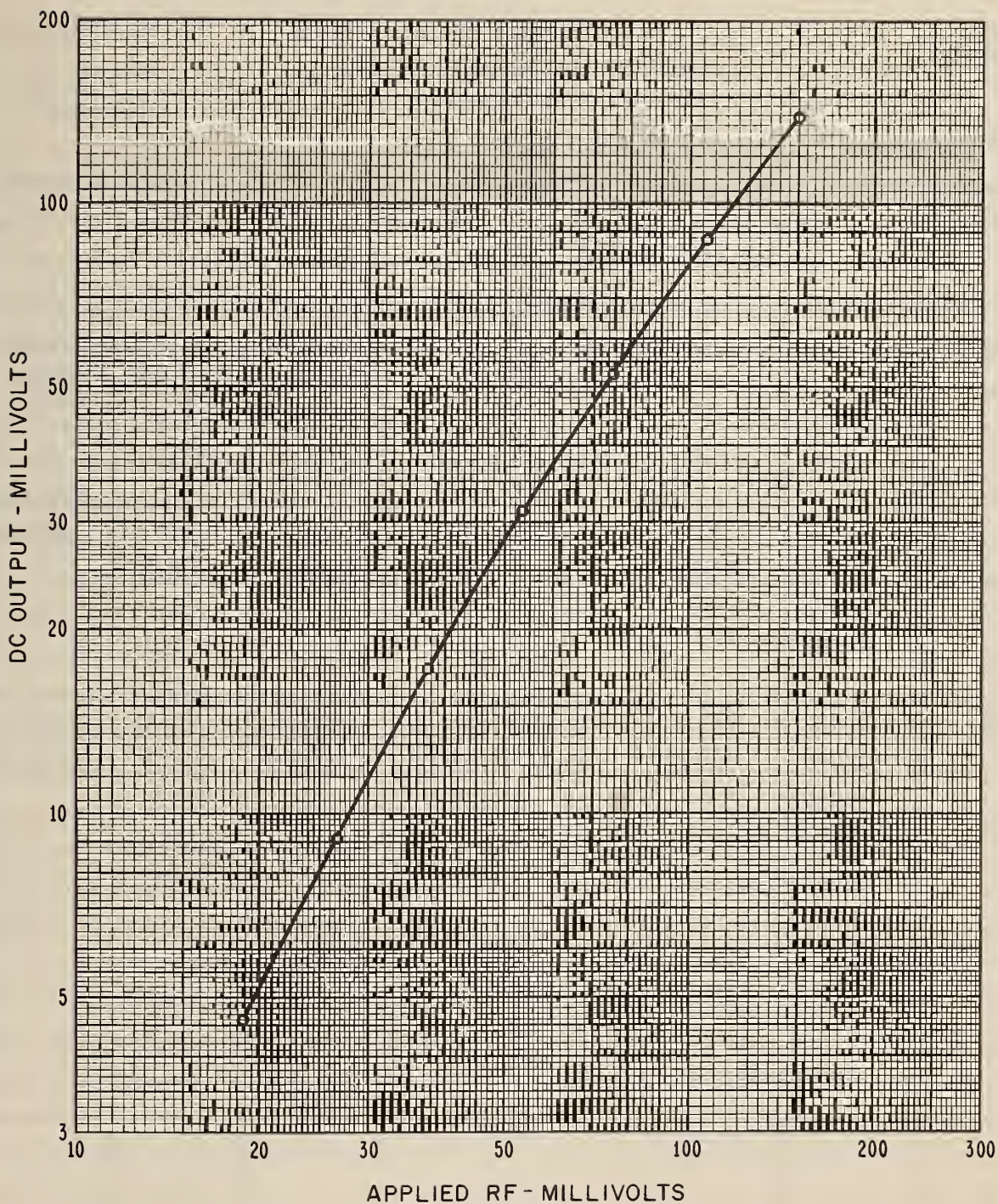

Figure 6.16. Sample Curve of the Applied RF Voltage to the Crystal Diode Plotted Against the DC Output of the Crystal.

KIND OF MEASUREMENT Dipole Antenna Factor

INSTRUMENT TESTED Std. Rx Antenna Crystal Output TEST No. 920362

FREQUENCY \_\_\_\_\_ ROOM TEMPERATURE \_\_\_\_\_ °C. HUMIDITY \_\_\_\_\_ % BAROMETER \_\_\_\_\_ MM.  
Crystal 1N832A

GPO : 1966 O-217-724

Band	Freq.	Crystal Output			Frequency Correction	Corrected Crystal Output	Induced Antenna voltage
		mV-dc	mV-dc	mV-dc			
	MHz						Vi mV-rf
1	400	58.0	58.0	58.0	1.0	58.0	80.0
	500	47.2	47.2	47.2	+	47.2	70.0
	600						
	700						
2	700	84.0	84.0	84.0	0.99	83.2	103.0
	800	12.0	12.0	12.0	0.98	11.8	30.8
	900						
	1000						

Figure 6.17. Sample Data Sheet for Dipole Antenna Calibration

U. S. DEPARTMENT OF COMMERCE  
NATIONAL BUREAU OF STANDARDS

DATE 12-12-66

SHEET NO. 5

OBSERVER JEC

KIND OF MEASUREMENT Dipole Antenna Calibration

INSTRUMENT TESTED NF-105 S.N. 1965 TEST No. 920362

FREQUENCY \_\_\_\_\_ ROOM TEMPERATURE \_\_\_\_\_ °C. HUMIDITY \_\_\_\_\_ % BAROMETER \_\_\_\_\_ MM.

Gain standardized in 20 dB attenuator position

GPO : 1966 O-217-724

Band	Freq. MHz	Attn. Position dB	Meter Reading (Average)			Ave. μV
			μV	μV	μV	
1	400	80.0	5.4	5.3	5.3	5.3
	500		2.3	2.3	2.3	2.3
	600					
	700					
2	700		3.2	3.3	3.3	3.3
	800		1.4	1.4	1.3	1.4
	900					
	1000	✓				

Figure 6.18. Sample Data Sheet for Dipole Antenna Calibration.

## 7.0 THE CALIBRATION REPORT.

### 7.1 General Discussion.

Upon completion of all measurements required for the calibration of an FIM, a very necessary and important task is the presentation of the calibration data to the user. This is usually accomplished by means of a calibration report. The report must be concise and simple but complete so that all calibration data are fully understood. A fully calibrated FIM is of no value if the calibration data are not understood or utilized by the user.

The typical FIM such as the NF-105 is a rather complex piece of measuring equipment. Measurements can be made by direct reading or by slideback, and there is peak detection and average detection. It is important that the calibration report explain fully the conditions under which the calibration was performed.

In the previous sections of this report examples of calibration data have been given for attenuation measurements, overall linearity, etc. In this section we are going to prepare a calibration report using the data sheets from the earlier sections. The report will be divided in the following manner:

1. Two-terminal RF Voltmeter Calibration
2. Attenuator Calibration
3. Overall Linearity Calibration
4. Loop Antenna Calibration
5. Dipole Antenna Calibration

A typical NBS Calibration Report of an NF-105 FIM is included in Section 7.6. This example is shown to help guide the user in preparation of the calibration data.

## 7.2 Two-Terminal RF Voltmeter Calibration.

The two-terminal voltmeter calibration was very straightforward: 100 microvolts were applied to the input of the receiver, and the receiver gain adjusted so the receiver read correctly; a setting of the impulse generator, equivalent to the 100-microvolt input, was then determined by substitution. A typical data sheet for a two-terminal r-f voltmeter calibration is shown in Figure 7.1. Note that all pertinent comments regarding the instrument are written on the data sheet. This information should be included in the final calibration report. The extreme right-hand column marked "AVE" in Figure 7.1 is the data listed in the calibration report.

## 7.3 Signal Input Attenuator Calibration.

Each attenuator step of the FIM has been measured, and now a corrected value or correction factor must be determined for each step. The two-terminal r-f voltmeter calibration was performed using the "20" dB attenuator step and "20" dB point on the panel meter. This establishes these two as the reference points for the attenuator and overall linearity correction data respectively. The "20" dB attenuator will be exactly 20.0 dB, and the panel meter reading will be exactly 20.0. Other attenuator steps and panel meter readings will be referenced to these two points.

The data sheet illustrated in Figure 7.2 shows the same data as recorded in Section 3.0, except that it has now been completed showing the the corrected values that are to be used on the calibration report. The "difference" column shows the measured value of each attenuator step. If the frequency is high and corrections must be applied to the standard attenuator readings, these corrections must be applied to the "difference" column. From the "difference" column the corrected attenuator settings can be determined by mere addition or subtraction. Notice the "20" dB

U. S. DEPARTMENT OF COMMERCE  
NATIONAL BUREAU OF STANDARDS

DATE 12-12-66

SHEET NO. 1

OBSERVER JLW

KIND OF MEASUREMENT RF Voltmeter Calibration

INSTRUMENT TESTED NF-105 Ser. No. 1965 TA tuning unit TEST NO. 920362

FREQUENCY \_\_\_\_\_ ROOM TEMPERATURE \_\_\_\_\_ °C. HUMIDITY \_\_\_\_\_ % BAROMETER \_\_\_\_\_ MM.

Imp. gen. controls: 10 cycles, P.R.R. @ x100, gain set in peak pos., attn, in 20 dB position, voltage readings taken in "carrier" pos., input voltage - 100 μV.

GPO : 1966 O-217-724

Band	Freq. MHz	Input voltage μV	Impulse dB	Generator dB	Settings dB	Ave. dB
1	0.15	100	85.2	85.2	85.1	85.2
	0.22		83.6	83.6	83.6	83.6
	0.29					
	0.36					
2	0.36		79.2	79.3	79.2	79.2
	0.53					
	0.70					
	0.87	γ				

Figure 7.1. Sample Data Sheet For RF Voltmeter Calibration.

U. S. DEPARTMENT OF COMMERCE  
NATIONAL BUREAU OF STANDARDS

DATE 12-12-66

SHEET NO. 2

OBSERVER JEC

KIND OF MEASUREMENT Attenuator Calibration

INSTRUMENT TESTED NF-105 Ser. No. 1965 T-X Tuning Unit TEST NO. 920362

FREQUENCY 150 kHz ROOM TEMPERATURE \_\_\_\_\_ °C. HUMIDITY \_\_\_\_\_ % BAROMETER \_\_\_\_\_ MM.

Gain standardized, function switch in "carrier"

GPO : 1966 O-217-724

Signal	Standard Attenuator Reading				Differ.	Corrected	Voltage
Attn. Pos.				Ave.		Attn. Set.	Correction
dB	dB	dB	dB	dB	dB	dB	Factor
80	0-0-2.5	0-0-2.5	0-0-2.5	2.5			
60	20-1-2.1	20-1-2.0	20-1-2.1	23.07	20.57	80.4	1.047
60	0-0-2.5	0-0-2.5	0-0-2.5	2.5		59.8	0.977
40	20-0-2.5	20-0-2.5	20-0-2.5	22.5	20.0		
40						39.8	0.977
20					19.8	20.0	1.0
20							
0					20.5	-0.5	0.994

Figure 7.2. Sample Data Sheet For Attenuator Calibration.

attenuator step is the reference attenuator and is 20.0 dB. The "40" dB step is determined by adding the 19.8 difference between the "20" and "40" steps to the 20.0 step giving 39.8. The "60" dB step is determined by adding the 20.0 difference between the "40" and "60" steps to the corrected "40" step ( $39.8 + 20.0 = 59.8$ ). Notice the corrected value of the "0" dB step; it is -0.5, because the difference between the "0" and the "20" steps is greater than 20.0 dB. The "0" corrected step is determined by subtracting the "difference" column from the corrected "20" dB step,  $20.0 - 20.5 = -0.5$ .

The units of the calibration reports can be either in decibels or in microvolts. The choice is usually determined by the user or the calibrator. If microvolts are selected, the corrected attenuator settings in decibels must be converted to an equivalent correction factor applicable to microvolts. This can be done easily by means of a decibel to voltage ratio table. The following relationship may be used to convert the corrected attenuator setting in decibels to an equivalent voltage correction factor:

$$\text{voltage correction factor} = \frac{\text{voltage ratio of the corrected attn. setting}}{\text{voltage ratio of the attn. setting}}$$

Example: Find the voltage correction factor for the "80" dB step which has a corrected attn. setting of 80.4 dB.

$$\text{voltage correction factor} = \frac{10470}{10000} = 1.047$$

The voltage correction factor should always be a number very close to 1.0. If it is not close to 1.0, a check should be made to determine if an error was made or if the attenuator is defective. The voltage correction factor for each step is shown in the extreme right-hand column of Figure 7.2. The sample observation sheet, shown on page 127, illustrates



how the calibration results are reported in both decibels and microvolts. Normally, the calibration results are reported in either decibels or microvolts. Note that the calibration report explains how to use the correction factors -- see paragraph at top of page 143.

#### 7.4 Overall Linearity Calibration.

The overall linearity calibration data are presented in a format similar to the attenuator calibration data. The meter reading can be corrected in terms of decibels or microvolts. A typical data sheet is illustrated in Figure 7.3. The panel meter was calibrated in microvolts. The column marked "Ave" is the standard attenuation readings between the different points on the panel meter. The "difference" column is the actual attenuation between the reference point (10 microvolts) and successive points on the panel meter. By converting this attenuation in the "difference" column to a voltage ratio and dividing the reference point (10 microvolts) by this voltage ratio, the corrected meter readings, in microvolts, are obtained. Any point on the panel meter can be made the reference point; the 10-microvolt point was selected because of the two-terminal r-f voltmeter calibration.

If decibels are selected for the panel meter calibration, the "difference" column decibel figures can be used directly to add or subtract in order to obtain the corrected meter readings in decibels. The overall linearity calibration report is shown on page 144 . Note that the calibration report gives instructions regarding use of the calibration data.

#### 7.5 Loop Antenna Calibration.

A calibrated loop antenna is one that has an antenna coefficient or antenna factor assigned at selected frequencies so that the loop antenna can be used to accurately measure field strengths when connected to a

U. S. DEPARTMENT OF COMMERCE  
NATIONAL BUREAU OF STANDARDS

DATE 12-12-66

SHEET NO. 3

OBSERVER JEC

KIND OF MEASUREMENT Overall Linearity

INSTRUMENT TESTED NF-105 S.N. 1965 TX Tuning Unit

TEST NO. 920362

FREQUENCY 90 kHz ROOM TEMPERATURE \_\_\_\_\_ °C. HUMIDITY \_\_\_\_\_ % BAROMETER \_\_\_\_\_ MM.

Gain standardized, Attn. pos. - 40 dB

GPO : 1966 O-217-724

reference 10  $\mu$ V

Meter Reading	Standard	Attn. Setting	Ave.	Difference	Voltage Ratio	Corrected Meter Read.
( $\mu$ V)	dB	dB	dB	dB		( $\mu$ V)
10			2.5	0.0	1.0	10.0
9			3.3	0.8	1.096	9.12
8			4.3	1.8	1.230	8.13
7			5.8	3.3	1.462	6.84
6			7.3	4.8	1.738	
5			9.1	6.6		
4			11.3	8.8		
3			13.9	11.4		
2			18.0	15.5		
1			25.6	23.1		

Figure 7.3. Sample Data Sheet For Overall Linearity Calibration.

calibrated receiver. A plot of the antenna factors permits accurate measurements at all frequencies. The antenna factor expresses the ratio of the magnitude of the correct field strength to the measured field strength. This number can be expressed as a direct ratio or in decibels. If the measurements are expressed in volts per meter, the antenna factor is a multiplier. If the measurements are expressed in decibels, the antenna factor is additive. The example used herein is for the LP-105 loop antenna and is computed in terms of volts per meter.

In Section 5.0 a sample data sheet was shown illustrating the measurement data of the loop antenna. A new data sheet, shown in Figure 7.4, is required to complete the necessary calculations of the antenna data. The meter reading of the receiver must be corrected using the overall linearity calibration data, and the attenuator setting of the receiver must be corrected using the attenuator calibration data so that the magnitude of the field measured by the FIM can be accurately determined. Column A of Figure 7.4 contains the uncorrected meter readings transcribed from the initial data sheet. Column B shows the meter readings after the overall linearity corrections have been made. Column C is the corrected attenuator setting. Column B and C are used to determine the measured field,  $E_m$ . The standard calibrating field,  $E_s$ , is listed in Column E. The antenna factor,  $K$ , is determined by dividing  $E_s$  by  $E_m$  as shown in Column F.

The calibration report lists the antenna calibration results on pages 145 and 146. The applicability of all calibration corrections is shown on the first page of the calibration report.

U. S. DEPARTMENT OF COMMERCE  
NATIONAL BUREAU OF STANDARDS

DATE 12-12-66

SHEET No. 5

OBSERVER JEC

KIND OF MEASUREMENT Loop Antenna Calibration

INSTRUMENT TESTED NF-105 S.N. 1965; IP-105; TA Tuning Unit TEST No. 920362

FREQUENCY \_\_\_\_\_ ROOM TEMPERATURE \_\_\_\_\_ °C. HUMIDITY \_\_\_\_\_ % BAROMETER \_\_\_\_\_ MM.

E for 1 meter spacing = 180.1 mV/m; E for 1.5 meter spacing = 54.3 mV/m

GPO : 1966 O-217-724

Band	Freq.	A	B	C	D	E	F
		Uncorr. Meter	Correct Meter	Correct Attn. Set	Measured Field $E_M$	Std Field $E_s$	Ant. Coef. $E_s/E_M = K$
	MHz	$\mu V$	$\mu V$		mV/m	mV/m	
1	0.15	1.61	1.46	1000	1.46	180.1	123.4
	0.22	1.98	1.91		1.91		94.3
	0.29	2.36	2.33		2.33		77.3
	0.36	2.60	2.57		2.57		70.1
4	2.1	1.92	2.06		2.06	54.53	26.5
	3.1						
	4.2						
	5.2	2.98	3.04		3.04	55.24	18.2
5	5.2						
	9.5						
	10.0						
	12.7	6.0	6.16		6.16	58.93	9.5

Figure 7.4. Sample Data Sheet For Loop Antenna Calibration.

## 7.6 Dipole Antenna Calibration.

The dipole antenna calibration data are presented in essentially the same format as the loop antenna data. The dipole antenna factor can also be expressed as a direct ratio or in decibels. The compilation of the calibration data is somewhat more complex than with the loop antenna, because the standard-antenna calibration data must also be handled.

Four data sheets are recommended:

1. For the FIM, see Figure 7.5.
2. For the standard receiving antenna, see Figure 7.6.
3. For the crystal diode calibration, see Figure 7.7.
4. For the calculation of the standard field  $E_s$ , see Figure 7.8.
5. For calculation of the antenna factor, see Figure 7.9.

Each sheet is self-explanatory. The final analysis is made on the antenna factor data sheet, Figure 7.9. The effective length is calculated by  $\frac{\lambda}{\pi}$ . The induced antenna voltage,  $V_1$ , is obtained from Figure 7.6. The standard calibrating field,  $E_s$ , is determined in terms of  $V_1$  and the effective length. The measured field,  $E_m$ , is determined by the corrected meter reading and the corrected attenuation columns. The antenna factor is then calculated by the relationship,  $K = E_s/E_m$ . The presentation of the data in the calibration report is shown on pages 147 and 148.

U. S. DEPARTMENT OF COMMERCE  
NATIONAL BUREAU OF STANDARDS

DATE 12-12-66

SHEET NO. 5

OBSERVER JEC

KIND OF MEASUREMENT Dipole Antenna Calibration

INSTRUMENT TESTED NF-105, S.N. 1965 TEST NO. 920362

FREQUENCY \_\_\_\_\_ ROOM TEMPERATURE \_\_\_\_\_ °C. HUMIDITY \_\_\_\_\_ % BAROMETER \_\_\_\_\_ MM.

Gain standardized in 20 dB attenuator position

GPO : 1966 O-217-724

Band	Freq.	Attn. Position	Meter Reading (Average)			Ave.
			$\mu\text{V}$	$\mu\text{V}$	$\mu\text{V}$	
	MHz	dB	$\mu\text{V}$	$\mu\text{V}$	$\mu\text{V}$	$\mu\text{V}$
1	400	80.0	5.4	5.3	5.3	5.3
	500		2.3	2.3	2.3	2.3
	600					
	700					
2	700		3.3	3.3	3.3	3.3
	800		1.4	1.4	1.3	1.4
	900					
	1000	r				

Figure 7.5. Sample Data Sheet for Dipole Antenna Calibration.

U. S. DEPARTMENT OF COMMERCE  
NATIONAL BUREAU OF STANDARDS

DATE 12-12-66

SHEET No. 6

OBSERVER JEC

KIND OF MEASUREMENT Dipole Antenna Calibration

INSTRUMENT TESTED Std. Rx Antenna Crystal Output TEST No. 920362

FREQUENCY \_\_\_\_\_ ROOM TEMPERATURE \_\_\_\_\_ °C. HUMIDITY \_\_\_\_\_ % BAROMETER \_\_\_\_\_ MM.

Crystal 1N832A

GPO : 1966 O-217-724

Band	Freq.	Crystal	Output	Ave	Frequency Corrected		Induced
					Correction	Crystal	
	MHz	mV-dc	mV-dc	mV-dc		Output	Voltage
						mV-dc	Vi
							mV-rf
1	400	80.0	80.0	80.0	1.0	80.0	80.0
	500	57.9	58.1	58.0	1.0	58.0	70.0
	600						
	700						
2	700	84.8	84.8	84.8	0.99	84.0	103.0
	800	19.8	19.8	19.8	0.98	19.4	30.8
	900						
	1000						

Figure 7.6. Sample Data Sheet for Dipole Antenna Calibration.

U. S. DEPARTMENT OF COMMERCE  
NATIONAL BUREAU OF STANDARDS

DATE 12-12-66  
SHEET NO. 7  
OBSERVER JEC

KIND OF MEASUREMENT Crystal Diode Calibration  
INSTRUMENT TESTED Xtal 1N832A TEST NO. 920367  
FREQUENCY 50 MHz ROOM TEMPERATURE \_\_\_\_\_ °C. HUMIDITY \_\_\_\_\_ % BAROMETER \_\_\_\_\_ MM.

GPO : 1966 O-217-724

	Crystal	Output		Atten.	RF		
			Ave.		Input		
mV-dc	mV-dc	mV-dc	mV-dc	dB	mV-rf		
139.1	139.2	139.1	139.1	0	150.0		
87.5	87.6	87.7	87.6	3	106.2		
53.3	53.3	53.3	53.3	6	75.2		
31.1	31.0	31.1	31.1	9	53.2		
17.3	17.3	17.3	17.3	12	37.7		
9.0	9.1	9.1	9.1	15	26.7		
4.6	4.6	4.6	4.6	18	18.9		

Figure 7.7. Sample Data Sheet for Crystal Diode Calibration.



U. S. DEPARTMENT OF COMMERCE  
NATIONAL BUREAU OF STANDARDS

DATE 12-12-66

SHEET No. 7

OBSERVER JEC

KIND OF MEASUREMENT Dipole Antenna Calibration

INSTRUMENT TESTED Std. Rx Antenna Measured Field TEST No. 920362

FREQUENCY \_\_\_\_\_ ROOM TEMPERATURE \_\_\_\_\_ °C. HUMIDITY \_\_\_\_\_ % BAROMETER \_\_\_\_\_ MM.

GPO : 1966 O-217-724

Band	Freq.	Induced Ant. Volt. Vi	Effective length $\lambda_{\text{eff}}$	$E_s$ $\frac{V_i}{\lambda_{\text{eff}}}$ mV/m			
1	400	80.0	0.239	334.7			
	500	70.0	0.191	366.5			
	600						
	700						
2	700	103.0	0.137	751.8			
	800	30.8	0.119	258.8			
	900						
	1000						

Figure 7.8. Sample Data Sheet for Computation of  $E_s$ .

U. S. DEPARTMENT OF COMMERCE  
NATIONAL BUREAU OF STANDARDS

DATE 12-12-66

SHEET NO. 8

OBSERVER JEC

KIND OF MEASUREMENT Dipole Antenna Calibration

INSTRUMENT TESTED NF-105 S.N. 1965 TEST NO. 920362

FREQUENCY \_\_\_\_\_ ROOM TEMPERATURE \_\_\_\_\_ °C. HUMIDITY \_\_\_\_\_ % BAROMETER \_\_\_\_\_ MM.

GPO : 1966 O-217-724

Band	Freq.	Corrected	Corrected	Measured	Std.	Ant. Factor
		Meter Reading	Attn. Set	Field, E <sub>M</sub>	Field, E <sub>S</sub>	E <sub>S</sub> /E <sub>M</sub> = K
	MHz	μV	μV	mV/m	mV/m	
1	400	5.0	10000	50.0	334.7	6.7
	500	2.1	10000	21.0	366.5	17.5
	600					
	700					
2	700	3.2	9700	31.0	751.8	24.3
	800	1.3	9700	12.6	258.8	20.5
	900					
	1000					

Figure 7.9. Sample Data Sheet for Dipole Antenna Factor.

U. S. DEPARTMENT OF COMMERCE  
NATIONAL BUREAU OF STANDARDS  
INSTITUTE FOR BASIC STANDARDS  
BOULDER, COLORADO 80302

REPORT OF CALIBRATION

NOISE AND FIELD INTENSITY METER  
Singer Company  
Model NF-105, Serial No. 1965

Submitted by:

The data in this report are for use in making rms cw measurements only and are not valid for broadband interference measurements.

Field strength may be determined with the loop and dipole antennas by using the following equation:

$$E = KMA$$

where

- E = unknown field strength in microvolts per meter,
- K = antenna factor,
- M = corrected meter reading, and
- A = corrected attenuator setting.

A minimum operating time of one hour was allowed before any measurements were made. The 60 Hertz ac supply voltage was approximately 115 v.

Page 1 of 10

Test No. 920362

Date: December 12, 1968

Noise and Field Intensity Meter  
 Singer Company  
 Model NF-105, Serial No. 1965

TWO-TERMINAL RF VOLTMETER CALIBRATION

This calibration was performed by applying 100 microvolts to the end of the green 30-foot coaxial cable connected to the "ANTENNA" connector on Switching Unit SU-105 with the SIGNAL INPUT ATTENUATOR in the "20" dB position, the function switch in the "CARRIER" position, and the IF GAIN adjusted to an output meter reading of 10 microvolts. The impulse generator settings were determined with the SIGNAL INPUT ATTENUATOR in the "20" dB position and the function switch in the "PEAK" position, referenced to an output meter reading of 10 microvolts. The pulse repetition rate of the impulse generator was set at 1000 Hz.

The uncertainty of the calibrating voltage was believed to be within 5 percent to 400 MHz and within 10 percent from 400 to 1000 MHz.

<u>Tuning Unit</u>	<u>Band</u>	<u>Frequency kHz</u>	<u>Impulse Generator Setting decibels</u>
TX/NF-105	1	14.0	92.6
		17.0	91.8
		21.0	90.7
		23.0	90.1
		25.0	90.3
	2	25.0	92.4
		35.0	90.2
		45.0	90.1
		55.0	90.8
		62.0	91.4
	3	62.0	91.0
		85.0	91.8
		105.0	98.3
		125.0	96.8
		150.0	93.6

Page 2 of 10

Test No. 920362

Date: December 12, 1968

Noise and Field Intensity Meter  
 Singer Company  
 Model NF-105, Serial No. 1965

<u>Tuning Unit</u>	<u>Band</u>	<u>Frequency MHz</u>	<u>Impulse Generator Setting decibels</u>
TA/NF-105	1	0.15	85.2
		0.22	83.6
		0.29	80.5
		0.36	80.9
	2	0.36	79.2
		0.50	76.5
		0.65	73.6
		0.86	73.7
	3	0.86	79.8
		1.2	76.7
		1.6	77.0
		2.1	76.8
	4	2.1	73.5
		3.0	72.3
		4.0	72.1
		5.2	73.0
	5	5.2	71.9
		7.5	73.5
		10.0	73.6
		12.7	72.0
	6	12.7	74.0
		18.0	72.4
		24.0	72.9
		30.0	72.9

Page 3 of 10

Test No. 920362

Date: December 12, 1968

Noise and Field Intensity Meter  
 Singer Company  
 Model NF-105, Serial No. 1965

<u>Tuning Unit</u>	<u>Band</u>	<u>Frequency MHz</u>	<u>Impulse Generator Setting decibels</u>
T1/NF-105	1	20	56.1
		30	55.9
		35	54.5
		50	55.8
		65	54.2
	2	65	56.2
		100	56.8
		150	56.4
		200	56.2
	T2/NF-105	1	200
250			46.3
300			45.8
350			48.0
400			46.3
T3/NF-105	1	400	41.4
		500	43.6
		600	43.6
		700	43.0
	2	700	43.7
		800	42.2
		900	42.9
		1000	43.5

Page 4 of 10

Test No. 920362

Date: December 12, 1968

Noise and Field Intensity Meter  
Singer Company  
Model NF-105, Serial No. 1965

SIGNAL INPUT ATTENUATOR CALIBRATION

This calibration was performed with the function switch placed in the "CARRIER" position, and the IF GAIN adjusted in accordance with the two-terminal r-f voltmeter calibration data. The corrected attenuator settings are referenced to the "20" dB attenuator setting. The corrected attenuator settings may be determined by multiplying the attenuation multiplier by the correction factor. The uncertainty of this calibration is believed to be within 2 percent at 0.015 and 300 MHz and within 3 percent at 1000 MHz.

<u>Attenuator Setting</u> decibels	<u>Attenuation</u> <u>Multiplier</u>	<u>Correction Factor</u>		
		<u>0.015 MHz</u>	<u>300 MHz</u>	<u>1000 MHz</u>
0	x 1	0.94	0.54	0.83
20	x 10	1.00	1.00	1.00
40	x 10 <sup>2</sup>	0.98	1.00	1.05
60	x 10 <sup>3</sup>	0.98	1.02	1.01
80	x 10 <sup>4</sup>	1.05	1.05	0.97

Page 5 of 10

Test No. 920362

Date: December 12, 1968

Noise and Field Intensity Meter  
 Singer Company  
 Model NF-105, Serial No. 1965

OVERALL LINEARITY CALIBRATION

The overall linearity was measured from the "ANTENNA" connector on Switching Unit SU-105 to the panel output meter, referenced to a meter reading of 10 microvolts. The measurements were made with the function switch placed in the "CARRIER" position, the SIGNAL INPUT ATTENUATOR in the "20" dB position, and the IF GAIN adjusted in accordance with the two-terminal r-f voltmeter calibration data. It is recommended that the linearity calibration data for the TA/NF-105 Tuning Unit be used as follows: The Band 3 corrections are for use with all bands having a 455 kHz IF (Bands 1 and 3); the Band 6 corrections are for use with all bands having a 1600 kHz IF (Bands 2, 4, 5, and 6). The uncertainty of this calibration is believed to be within 2 percent at 0.090, 1.5, 30, 200, and 300 MHz and within 3 percent at 1000 MHz.

Corrected Meter Reading

Indicated Meter Reading microvolts	<u>TX/NF-105</u>	<u>TA/NF-105</u>		<u>T1/NF-105</u>	<u>T2/NF-105</u>	<u>T3/NF-105</u>
	Band 3	Band 3	Band 6	Band 2	Band 1	Band 2
	0.090 MHz	1.5 MHz	30 MHz	200 MHz	300 MHz	1000 MHz
1	1.03	0.72	1.15	0.98	0.46	0.70
2	1.95	1.93	2.13	1.95	1.59	1.67
3	2.82	2.95	3.07	2.92	2.69	2.68
4	3.85	4.07	4.17	3.94	3.80	3.65
5	4.73	5.07	5.19	5.01	4.79	4.67
6	5.89	6.09	6.16	6.09	5.90	5.79
7	6.84	7.16	7.25	7.16	7.05	6.86
8	8.13	8.32	8.41	8.13	8.31	8.15
9	9.12	9.33	9.33	9.12	9.28	9.13
10	10.00	10.00	10.00	10.00	10.00	10.00

Page 6 of 10

Test No. 920362

Date: December 12, 1968



ANTENNA CALIBRATION

The loop antenna was calibrated in terms of a quasi-static magnetic field. The dipole antennas were calibrated in terms of a horizontally-polarized field for an antenna height of 10 feet. Approximate corrections for other heights may be obtained from NBS Research Paper RP 2062.

LOOP ANTENNAS

The IF GAIN was adjusted with the function switch placed in the "PEAK" position and the SIGNAL INPUT ATTENUATOR in the "40" dB position using the impulse generator settings listed on pages 2 and 3 of this report. The antenna factors were determined with the function switch placed in the "CARRIER" position. The uncertainty of the calibrating field was believed to be within 3 percent to 5 MHz and within 5 percent from 5 to 30 MHz.

LG-105 Loop Antenna

<u>Tuning Unit</u>	<u>Band</u>	<u>Frequency kHz</u>	<u>Antenna Factor</u>
TX/NF-105	1	14.0	81.4
		17.0	66.9
		21.0	51.1
		23.0	43.6
		25.0	
	2	25.0	52.1
		35.0	34.9
		45.0	30.2
		55.0	30.0
		62.0	30.9
	3	62.0	23.2
		85.0	22.4
		105.0	41.5
		125.0	30.2
		150.0	20.3

Noise and Field Intensity Meter  
 Singer Company  
 Model NF-105, Serial No. 1965

LP-105 Loop Antenna

<u>Tuning Unit</u>	<u>Band</u>	<u>Frequency MHz</u>	<u>Antenna Factor</u>
TA/NF-105	1	0.15	123.4
		0.22	94.3
		0.29	77.3
		0.36	70.1
	2	0.36	70.4
		0.50	51.7
		0.65	41.1
		0.86	37.6
	3	0.86	44.8
		1.2	33.8
		1.6	31.3
		2.1	29.5
	4	2.1	26.5
		3.0	19.9
		4.0	17.5
		5.2	18.2
	5	5.2	14.6
		7.5	13.0
		10.0	11.9
		12.7	9.5
6	12.7	11.6	
	18.0	8.3	
	24.0	9.0	
	30.0	8.4	

Page 8 of 10

Test No. 920362

Date: December 12, 1968

Noise and Field Intensity Meter  
 Singer Company  
 Model NF-105, Serial No. 1965

DIPOLE ANTENNA

The IF GAIN was adjusted with function switch placed in the "PEAK" position and the SIGNAL INPUT ATTENUATOR in the "20" dB position using the impulse generator settings listed on page 4 of this report. The antenna factors were determined with the function switch placed in the "CARRIER" position. The uncertainty of the calibrating field was believed to be within 10 percent to 400 MHz and within 12 percent from 400 to 1000 MHz.

DM-105-T1 Antenna

<u>Tuning Unit</u>	<u>Band</u>	<u>Frequency MHz</u>	<u>Antenna Factor</u>
T1/NF-105	1	30	1.03
		35	1.06
		50	1.69
		65	1.83
	2	65	1.98
		100	3.07
		150	4.80
		200	5.09

DM-105-T2 Antenna

<u>Tuning Unit</u>	<u>Band</u>	<u>Frequency MHz</u>	<u>Antenna Factor</u>
T2/NF-105	1	200	4.48
		250	7.17
		300	7.17
		350	8.07
		400	9.75

Page 9 of 10  
 Test No. 920362  
 Date: December 12, 1968

Noise and Field Intensity Meter  
Singer Company  
Model NF-105, Serial No. 1965

DM-105-T3 Antenna

<u>Tuning Unit</u>	<u>Band</u>	<u>Frequency MHz</u>	<u>Antenna Factor</u>	
T3/NF-105	1	400	6.7	
		500	17.5	
		600	16.6	
		700	23.0	
	2	700	24.3	
		800	20.5	
		900	27.4	
		1000	36.1	

For the Director

Page 10 of 10

Test No. 920362

Date: December 12, 1968

## REFERENCES

1. Diamond, H., K.A. Norton, and E.G. Lapham, On the accuracy of radio field-intensity measurements at broadcast frequencies, NBS J. Res. 21, December 1938.
2. Ries, F.X., and G. Rebuldela, High frequency microvolt measurements, ISA Conference 1963, Preprint No. 37.2.63.
3. Greene, F.M., Calibration of commercial radio field-strength meters at the National Bureau of Standards, NBS Circular 517, 1951.
4. Jean, A.G., H.E. Taggart, and J.R. Wait, Calibration of loop antennas at VLF, NBS J. Res. 65, No. 3, 1961.
5. Taggart, H.E., Field strength calibration techniques at the National Bureau of Standards, IEEE Trans. EMC, EMC-7, No. 2, June 1965.
6. Klaus, J.D., Antennas (McGraw-Hill Book Co., Inc., New York, N.Y.), 1950.
7. Greene, F.M., Influence of the ground on the calibration and use of VHF field-intensity meters, NBS J. Res. 44, February 1950.
8. Schelkunoff, S.A., Theory of antennas of arbitrary size and shape, Proc, IRE 29, No. 9, 1941.
9. Greene, F.M., and M. Solow, Development of very-high-frequency field intensity standards, NBS J. Res. 44, May 1950.
10. Greene, F.M., The near-zone magnetic field of a small circular-loop antenna, NBS J. Res., 71C, No. 4, December 1967.

# DECIBELS vs. VOLTAGE AND POWER

The Decibel Chart below indicates DB for any ratio of voltage or power up to 100 DB. For voltage ratios greater than 10 (or power ratios greater than 100) the ratio can be broken down into two products, the DB found for each separately, the two results then added. For example: To convert a voltage ratio of 200:1 to DB: 200:1 VR equals the product of 100:1 and 2:1. 100:1 equals 40 DB; 2:1 equals 6 DB. Therefore, 200:1 VR equals 40 DB + 6 DB or 46 DB.

Voltage Ratio	Power Ratio	-db +	Voltage Ratio	Power Ratio	Voltage Ratio	Power Ratio	-db +	Voltage Ratio	Power Ratio	Voltage Ratio	Power Ratio	-db +	Voltage Ratio	Power Ratio
1.0000	1.0000	0	1.000	1.000	.4467	.1995	7.0	2.239	5.012	.1995	.03981	14.0	5.012	25.12
.9886	.9772	.1	1.012	1.023	.4416	.1950	7.1	2.265	5.129	.1972	.03890	14.1	5.070	25.70
.9772	.9550	.2	1.023	1.047	.4365	.1905	7.2	2.291	5.248	.1950	.03802	14.2	5.129	26.30
.9661	.9333	.3	1.035	1.072	.4315	.1862	7.3	2.317	5.370	.1928	.03715	14.3	5.188	26.92
.9550	.9120	.4	1.047	1.096	.4266	.1820	7.4	2.344	5.495	.1905	.03631	14.4	5.248	27.54
.9441	.8913	.5	1.059	1.122	.4217	.1778	7.5	2.371	5.623	.1884	.03548	14.5	5.309	28.18
.9333	.8710	.6	1.072	1.148	.4169	.1738	7.6	2.397	5.754	.1862	.03467	14.6	5.370	28.84
.9226	.8511	.7	1.084	1.175	.4121	.1698	7.7	2.427	5.888	.1841	.03388	14.7	5.433	29.51
.9120	.8318	.8	1.096	1.202	.4074	.1660	7.8	2.455	6.026	.1820	.03311	14.8	5.495	30.20
.9016	.8128	.9	1.109	1.230	.4027	.1622	7.9	2.483	6.166	.1799	.03236	14.9	5.559	30.90
.8913	.7943	1.0	1.122	1.259	.3981	.1585	8.0	2.512	6.310	.1778	.03162	15.0	5.623	31.62
.8810	.7762	1.1	1.135	1.288	.3936	.1549	8.1	2.541	6.457	.1758	.03090	15.1	5.689	32.36
.8710	.7586	1.2	1.148	1.318	.3890	.1514	8.2	2.570	6.607	.1738	.03020	15.2	5.754	33.11
.8610	.7413	1.3	1.161	1.349	.3846	.1479	8.3	2.600	6.761	.1718	.02951	15.3	5.821	33.88
.8511	.7244	1.4	1.175	1.380	.3802	.1445	8.4	2.630	6.918	.1698	.02884	15.4	5.888	34.67
.8414	.7079	1.5	1.189	1.413	.3758	.1413	8.5	2.661	7.079	.1679	.02818	15.5	5.957	35.48
.8318	.6918	1.6	1.202	1.445	.3715	.1380	8.6	2.692	7.244	.1660	.02754	15.6	6.026	36.31
.8222	.6761	1.7	1.216	1.479	.3673	.1349	8.7	2.723	7.413	.1641	.02692	15.7	6.095	37.15
.8128	.6607	1.8	1.230	1.514	.3631	.1318	8.8	2.754	7.586	.1622	.02630	15.8	6.166	38.02
.8035	.6457	1.9	1.245	1.549	.3589	.1288	8.9	2.786	7.762	.1603	.02570	15.9	6.237	38.90
.7943	.6310	2.0	1.259	1.585	.3548	.1259	9.0	2.818	7.943	.1585	.02512	16.0	6.310	39.81
.7852	.6166	2.1	1.274	1.622	.3508	.1230	9.1	2.851	8.128	.1567	.02455	16.1	6.383	40.74
.7762	.6026	2.2	1.288	1.660	.3467	.1202	9.2	2.884	8.318	.1549	.02399	16.2	6.457	41.69
.7674	.5888	2.3	1.303	1.698	.3428	.1175	9.3	2.917	8.511	.1531	.02344	16.3	6.531	42.66
.7586	.5754	2.4	1.318	1.738	.3388	.1148	9.4	2.951	8.710	.1514	.02291	16.4	6.607	43.65
.7499	.5623	2.5	1.334	1.778	.3350	.1122	9.5	2.985	8.913	.1496	.02239	16.5	6.683	44.67
.7413	.5495	2.6	1.349	1.820	.3311	.1096	9.6	3.020	9.120	.1479	.02188	16.6	6.761	45.71
.7328	.5370	2.7	1.365	1.862	.3273	.1072	9.7	3.055	9.333	.1462	.02138	16.7	6.839	46.77
.7244	.5248	2.8	1.380	1.905	.3236	.1047	9.8	3.090	9.550	.1445	.02089	16.8	6.918	47.86
.7161	.5129	2.9	1.396	1.950	.3199	.1023	9.9	3.126	9.772	.1429	.02042	16.9	6.998	48.98
.7079	.5012	3.0	1.413	1.995	.3162	.1000	10.0	3.162	10.000	.1413	.01995	17.0	7.079	50.12
.6998	.4898	3.1	1.429	2.042	.3126	.09772	10.1	3.199	10.23	.1396	.01950	17.1	7.161	51.29
.6918	.4786	3.2	1.445	2.089	.3090	.09550	10.2	3.236	10.47	.1380	.01905	17.2	7.244	52.48
.6839	.4677	3.3	1.462	2.138	.3055	.09333	10.3	3.273	10.72	.1365	.01862	17.3	7.328	53.70
.6761	.4571	3.4	1.479	2.188	.3020	.09120	10.4	3.311	10.96	.1349	.01820	17.4	7.413	54.95
.6683	.4467	3.5	1.496	2.239	.2985	.08913	10.5	3.350	11.22	.1334	.01778	17.5	7.499	56.23
.6607	.4365	3.6	1.514	2.291	.2951	.08710	10.6	3.388	11.48	.1318	.01738	17.6	7.586	57.54
.6531	.4266	3.7	1.531	2.344	.2917	.08511	10.7	3.428	11.75	.1303	.01698	17.7	7.674	58.88
.6457	.4169	3.8	1.549	2.399	.2884	.08318	10.8	3.467	12.02	.1288	.01660	17.8	7.762	60.26
.6383	.4074	3.9	1.567	2.455	.2851	.08128	10.9	3.508	12.30	.1274	.01622	17.9	7.852	61.66
.6310	.3981	4.0	1.585	2.512	.2818	.07943	11.0	3.548	12.59	.1259	.01585	18.0	7.943	63.10
.6237	.3890	4.1	1.603	2.570	.2786	.07762	11.1	3.589	12.88	.1245	.01549	18.1	8.035	64.57
.6166	.3802	4.2	1.622	2.630	.2754	.07586	11.2	3.631	13.18	.1230	.01514	18.2	8.128	66.07
.6095	.3715	4.3	1.641	2.692	.2723	.07413	11.3	3.673	13.49	.1216	.01479	18.3	8.222	67.61
.6026	.3631	4.4	1.660	2.754	.2692	.07244	11.4	3.715	13.80	.1202	.01445	18.4	8.318	69.18
.5957	.3548	4.5	1.679	2.818	.2661	.07079	11.5	3.758	14.13	.1189	.01413	18.5	8.414	70.79
.5888	.3467	4.6	1.698	2.884	.2630	.06918	11.6	3.802	14.45	.1175	.01380	18.6	8.511	72.44
.5821	.3388	4.7	1.718	2.951	.2600	.06761	11.7	3.846	14.79	.1161	.01349	18.7	8.610	74.13
.5754	.3311	4.8	1.738	3.020	.2570	.06607	11.8	3.890	15.14	.1148	.01318	18.8	8.710	75.86
.5689	.3236	4.9	1.758	3.090	.2541	.06457	11.9	3.936	15.49	.1135	.01288	18.9	8.811	77.62
.5623	.3162	5.0	1.778	3.162	.2512	.06310	12.0	3.981	15.85	.1122	.01259	19.0	8.913	79.43
.5559	.3090	5.1	1.799	3.236	.2483	.06166	12.1	4.027	16.22	.1109	.01230	19.1	9.016	81.28
.5495	.3020	5.2	1.820	3.311	.2455	.06026	12.2	4.074	16.60	.1096	.01202	19.2	9.120	83.18
.5433	.2951	5.3	1.841	3.388	.2427	.05888	12.3	4.121	16.98	.1084	.01175	19.3	9.226	85.11
.5370	.2884	5.4	1.862	3.467	.2399	.05754	12.4	4.169	17.38	.1072	.01148	19.4	9.333	87.10
.5309	.2818	5.5	1.884	3.548	.2371	.05623	12.5	4.217	17.78	.1059	.01122	19.5	9.441	89.13
.5248	.2754	5.6	1.905	3.631	.2344	.05495	12.6	4.266	18.20	.1047	.01096	19.6	9.550	91.20
.5188	.2692	5.7	1.928	3.715	.2317	.05370	12.7	4.315	18.62	.1035	.01072	19.7	9.661	93.33
.5129	.2630	5.8	1.950	3.802	.2291	.05248	12.8	4.365	19.05	.1023	.01047	19.8	9.772	95.50
.5070	.2570	5.9	1.972	3.890	.2265	.05129	12.9	4.416	19.50	.1012	.01023	19.9	9.886	97.72
.5012	.2512	6.0	1.995	3.981	.2239	.05012	13.0	4.467	19.95	.1000	.01000	20.0	10.000	100.00
.4955	.2455	6.1	2.018	4.074	.2213	.04898	13.1	4.519	20.42			30	10 <sup>3</sup>	
.4898	.2399	6.2	2.042	4.169	.2188	.04786	13.2	4.571	20.89		10 <sup>-3</sup>	40	10 <sup>4</sup>	
.4842	.2344	6.3	2.065	4.266	.2163	.04677	13.3	4.624	21.38		10 <sup>-4</sup>	50	10 <sup>5</sup>	
.4786	.2291	6.4	2.089	4.365	.2138	.04571	13.4	4.677	21.88		10 <sup>-5</sup>	60	10 <sup>6</sup>	
.4732	.2239	6.5	2.113	4.467	.2113	.04467	13.5	4.732	22.39		10 <sup>-6</sup>	70	10 <sup>7</sup>	
.4677	.2188	6.6	2.138	4.571	.2089	.04365	13.6	4.786	22.91		10 <sup>-7</sup>	80	10 <sup>8</sup>	
.4624	.2138	6.7	2.163	4.677	.2065	.04266	13.7	4.842	23.44		10 <sup>-8</sup>	90	10 <sup>9</sup>	
.4571	.2089	6.8	2.188	4.786	.2042	.04169	13.8	4.898	23.99		10 <sup>-9</sup>		10 <sup>10</sup>	
.4519	.2042	6.9	2.213	4.898	.2018	.04074	13.9	4.955	24.55		10 <sup>-10</sup>	100		

## D.C. CALIBRATION UNIT

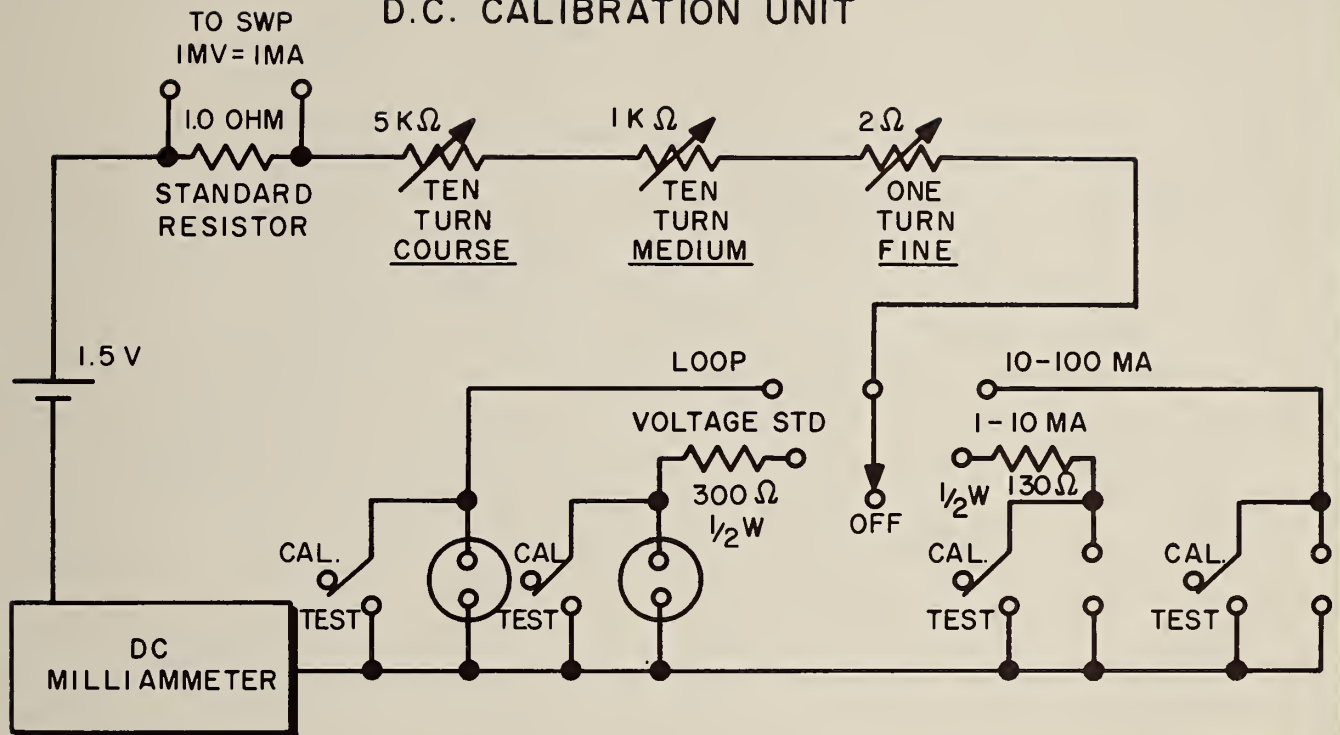

<u>ITEM</u>	<u>FUNCTION</u>
Battery	1.5 volt Battery
Twinax Connectors	Teflon, UG-103/U
Dials	Turn Counters
Jacks	D.C. Connectors
D.C. Meter	0-200 milliamperes
Variable Resistor	5K ohms, ten turn
Variable Resistor	1K ohms, ten turn
Variable Resistor	2 ohms, one turn
Standard Resistor	One ohm
Switch, wafer	Function Switch
Switches	TEST-CAL, position switches

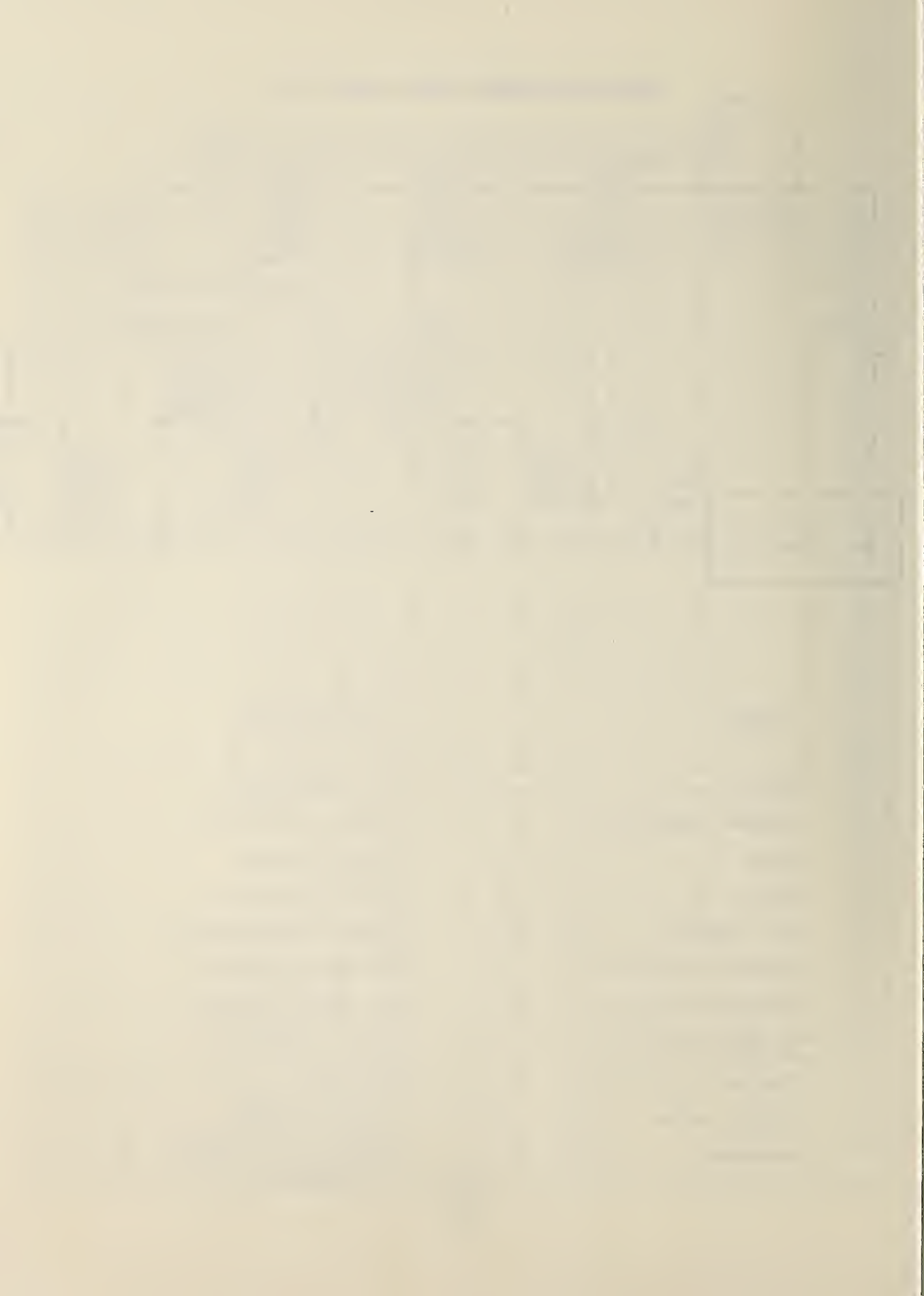



# NBS TECHNICAL PUBLICATIONS

## PERIODICALS

**JOURNAL OF RESEARCH** reports National Bureau of Standards research and development in physics, mathematics, chemistry, and engineering. Comprehensive scientific papers give complete details of the work, including laboratory data, experimental procedures, and theoretical and mathematical analyses. Illustrated with photographs, drawings, and charts.

*Published in three sections, available separately:*

### ● Physics and Chemistry

Papers of interest primarily to scientists working in these fields. This section covers a broad range of physical and chemical research, with major emphasis on standards of physical measurement, fundamental constants, and properties of matter. Issued six times a year. Annual subscription: Domestic, \$6.00; foreign, \$7.25\*.

### ● Mathematical Sciences

Studies and compilations designed mainly for the mathematician and theoretical physicist. Topics in mathematical statistics, theory of experiment design, numerical analysis, theoretical physics and chemistry, logical design and programming of computers and computer systems. Short numerical tables. Issued quarterly. Annual subscription: Domestic, \$2.25; foreign, \$2.75\*.

### ● Engineering and Instrumentation

Reporting results of interest chiefly to the engineer and the applied scientist. This section includes many of the new developments in instrumentation resulting from the Bureau's work in physical measurement, data processing, and development of test methods. It will also cover some of the work in acoustics, applied mechanics, building research, and cryogenic engineering. Issued quarterly. Annual subscription: Domestic, \$2.75; foreign, \$3.50\*.

## TECHNICAL NEWS BULLETIN

The best single source of information concerning the Bureau's research, developmental, cooperative and publication activities, this monthly publication is designed for the industry-oriented individual whose daily work involves intimate contact with science and technology—for *engineers, chemists, physicists, research managers, product-development managers, and company executives*. Annual subscription: Domestic, \$3.00; foreign, \$4.00\*.

\*Difference in price is due to extra cost of foreign mailing.

Order NBS publications from:

Superintendent of Documents  
Government Printing Office  
Washington, D.C. 20402

## NONPERIODICALS

**Applied Mathematics Series.** Mathematical tables, manuals, and studies.

**Building Science Series.** Research results, test methods, and performance criteria of building materials, components, systems, and structures.

**Handbooks.** Recommended codes of engineering and industrial practice (including safety codes) developed in cooperation with interested industries, professional organizations, and regulatory bodies.

**Special Publications.** Proceedings of NBS conferences, bibliographies, annual reports, wall charts, pamphlets, etc.

**Monographs.** Major contributions to the technical literature on various subjects related to the Bureau's scientific and technical activities.

**National Standard Reference Data Series.** NSRDS provides quantitative data on the physical and chemical properties of materials, compiled from the world's literature and critically evaluated.

**Product Standards.** Provide requirements for sizes, types, quality and methods for testing various industrial products. These standards are developed cooperatively with interested Government and industry groups and provide the basis for common understanding of product characteristics for both buyers and sellers. Their use is voluntary.

**Technical Notes.** This series consists of communications and reports (covering both other agency and NBS-sponsored work) of limited or transitory interest.

**Federal Information Processing Standards Publications.** This series is the official publication within the Federal Government for information on standards adopted and promulgated under the Public Law 89-306, and Bureau of the Budget Circular A-86 entitled, Standardization of Data Elements and Codes in Data Systems.

## CLEARINGHOUSE

The Clearinghouse for Federal Scientific and Technical Information, operated by NBS, supplies unclassified information related to Government-generated science and technology in defense, space, atomic energy, and other national programs. For further information on Clearinghouse services, write:

Clearinghouse  
U.S. Department of Commerce  
Springfield, Virginia 22151

U.S. DEPARTMENT OF COMMERCE  
WASHINGTON, D.C. 20230

POSTAGE AND FEES PAID  
U.S. DEPARTMENT OF COMMERCE

OFFICIAL BUSINESS

---