



NBS

TECHNICAL NOTE

National Bureau of Standards
Library, E-01 Admin. Bldg. ✓

JUN 23 1967

353

Connector for Saturated Standard Cells

J. J. BARTH



U.S. DEPARTMENT OF COMMERCE
National Bureau of Standards

THE NATIONAL BUREAU OF STANDARDS

The National Bureau of Standards¹ provides measurement and technical information services essential to the efficiency and effectiveness of the work of the Nation's scientists and engineers. The Bureau serves also as a focal point in the Federal Government for assuring maximum application of the physical and engineering sciences to the advancement of technology in industry and commerce. To accomplish this mission, the Bureau is organized into three institutes covering broad program areas of research and services:

THE INSTITUTE FOR BASIC STANDARDS . . . provides the central basis within the United States for a complete and consistent system of physical measurements, coordinates that system with the measurement systems of other nations, and furnishes essential services leading to accurate and uniform physical measurements throughout the Nation's scientific community, industry, and commerce. This Institute comprises a series of divisions, each serving a classical subject matter area:

—Applied Mathematics—Electricity—Metrology—Mechanics—Heat—Atomic Physics—Physical Chemistry—Radiation Physics—Laboratory Astrophysics²—Radio Standards Laboratory,² which includes Radio Standards Physics and Radio Standards Engineering—Office of Standard Reference Data.

THE INSTITUTE FOR MATERIALS RESEARCH . . . conducts materials research and provides associated materials services including mainly reference materials and data on the properties of materials. Beyond its direct interest to the Nation's scientists and engineers, this Institute yields services which are essential to the advancement of technology in industry and commerce. This Institute is organized primarily by technical fields:

—Analytical Chemistry—Metallurgy—Reactor Radiations—Polymers—Inorganic Materials—Cryogenics²—Materials Evaluation Laboratory—Office of Standard Reference Materials.

THE INSTITUTE FOR APPLIED TECHNOLOGY . . . provides technical services to promote the use of available technology and to facilitate technological innovation in industry and government. The principal elements of this Institute are:

—Building Research—Electronic Instrumentation—Textile and Apparel Technology Center—Technical Analysis—Center for Computer Sciences and Technology—Office of Weights and Measures—Office of Engineering Standards Services—Office of Invention and Innovation—Clearinghouse for Federal Scientific and Technical Information.³

¹ Headquarters and Laboratories at Gaithersburg, Maryland, unless otherwise noted; mailing address Washington, D. C., 20234.

² Located at Boulder, Colorado, 80302.

³ Located at 5285 Port Royal Road, Springfield, Virginia, 22151.

UNITED STATES DEPARTMENT OF COMMERCE
Alexander B. Trowbridge, Acting Secretary
NATIONAL BUREAU OF STANDARDS • A. V. Astin, Director



TECHNICAL NOTE 353

ISSUED April 21, 1967

CONNECTOR FOR SATURATED STANDARD CELLS

J. J. BARTH

Radio Standards Laboratory
Institute for Basic Standards
National Bureau of Standards
Boulder, Colorado

NBS Technical Notes are designed to supplement the Bureau's regular publications program. They provide a means for making available scientific data that are of transient or limited interest. Technical Notes may be listed or referred to in the open literature.

Connector for Saturated Standard Cells

by

Joseph J. Barth
National Bureau of Standards
Boulder, Colorado

ABSTRACT

This paper describes a connector used for making electrical connections to saturated standard cells in oil baths. The connector has at least three advantages over other methods in common use. These advantages are namely: (1) it does not generate thermoelectromotive forces; (2) it allows cell racks to be placed close together in the bath; and (3) it is economical to fabricate since it can be made from a common inside caliper.

Key Words: connector, electromotive force, oil baths, standard cells, thermoelectric.

CONNECTOR FOR SATURATED STANDARD CELLS

Saturated standard cells, when used in temperature-controlled oil baths, are mounted in racks with provisions made for electrical connections.

For many years, most saturated standard cells were used in racks utilizing mercury cups as the means for electrical contact.

About a decade ago, commercially produced cell racks, with rigid copper contact posts, were introduced for use in oil baths as well as air baths, and today this type is used extensively. Several methods of connecting to the copper posts of this type of rack have been used, including spring clips, alligator clips, etc. In these procedures there is danger of shorting the connections and thus destroying the cell. The possibility also exists that unwanted thermoelectromotive forces will be created by the dissimilar metal of the clips. Additionally, the bulkiness of some of these connections makes it necessary to maintain an appreciable distance between the cell racks, which can seriously reduce the usable capacity of the bath.

A connector that has been designed for making these connections is shown in Fig. 1. It is convenient to use, thermal free, and cannot accidentally short the cell connections. It is a special type of connector in that it is designed to fit between the posts of the cell rack. This feature allows the cell racks to be placed close together. Therefore, a bath of given size is able to accommodate more cells than might be possible with the methods mentioned previously. The connector is versatile as it can be used with different cell racks even though the spacing between the connecting posts may vary appreciably. It is inexpensive and is easily fabricated from a common inside caliper of the type used in the machine shop.

The connector (as shown in Fig. 2) is operated by depressing the acrylic plastic grips (4) and when it is placed on the cell rack (10), an outward pressure of the steel arms (5), made possible by the "C" spring (1) and pivot pin (3), forces the acrylic plastic insulating blocks (7), with special copper contact points (8), to fit against the inside of the cell rack posts (9). Connecting wires are soldered to the contact points (6) and inserted through holes (7) extending through and out of the top of the insulating blocks. The maximum outward travel of the arms is controlled by the screw stop (2).

The connector may be disassembled by outward pressure of the arms, forcing the "C" spring to snap off. It may be reassembled in the reverse manner.

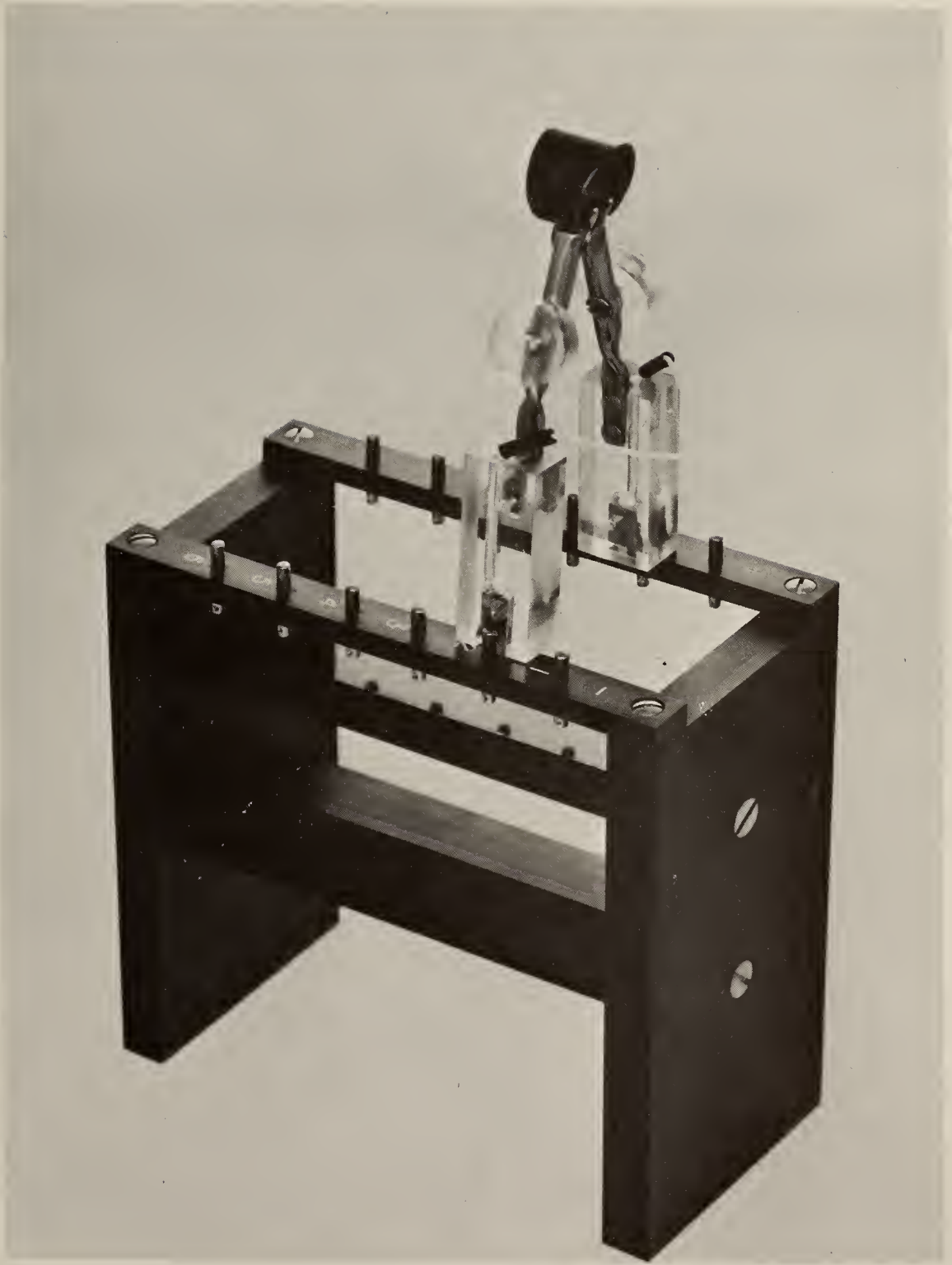

Fig. 1 Photograph of connector mounted on standard-cell rack

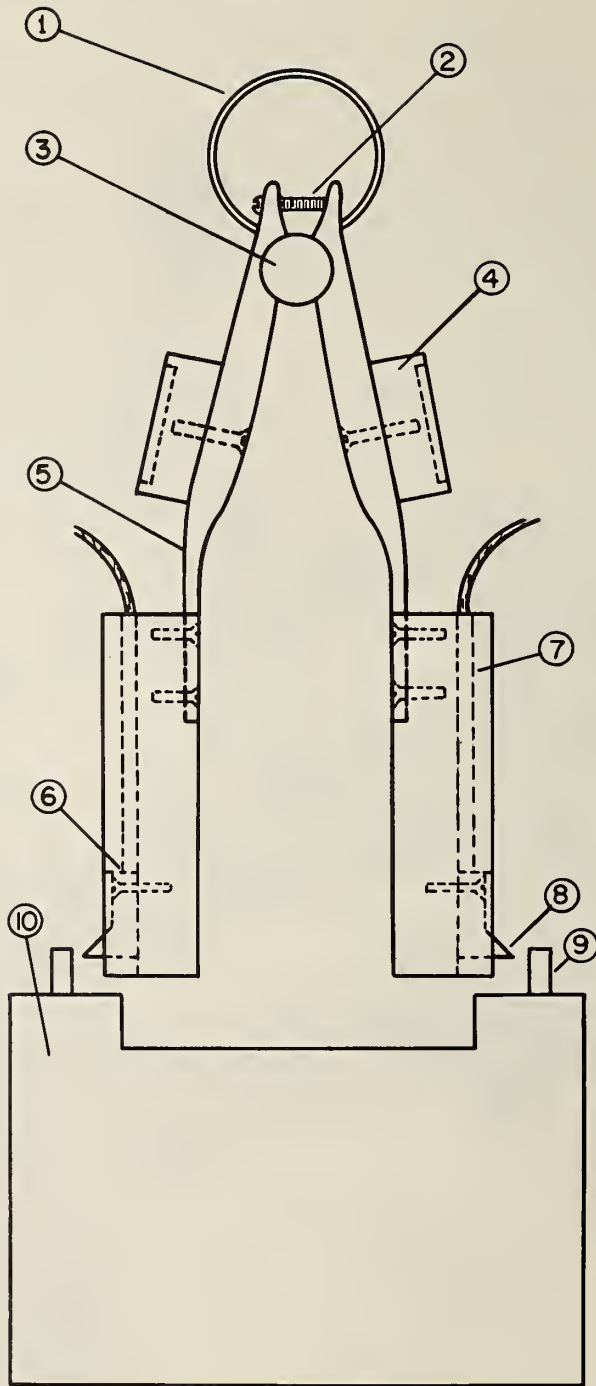

Fig. 2 Construction detail of connector



U.S. DEPARTMENT OF COMMERCE
WASHINGTON, D.C. 20230

POSTAGE AND FEES PAID
U.S. DEPARTMENT OF COMMERCE

OFFICIAL BUSINESS
