



NIST
PUBLICATIONS

NIST Technical Note 1265

***Guidelines for Realizing the
International Temperature Scale of
1990 (ITS-90)***

B. W. Mangum and G. T. Furukawa

QC
100
.U5753
#1265
1990
C.2

NATIONAL INSTITUTE OF STANDARDS &
TECHNOLOGY
Research Information Center
Gaithersburg, MD 20899

NISTC
DC 100
45753
#1865
1990
C.2.

NIST Technical Note 1265

Guidelines for Realizing the International Temperature Scale of 1990 (ITS-90)

B. W. Mangum
G. T. Furukawa

Center for Chemical Technology
National Measurement Laboratory
National Institute of Standards and Technology
Gaithersburg, MD 20899

August 1990



U.S. Department of Commerce
Robert A. Mosbacher, Secretary

National Institute of Standards and Technology
John W. Lyons, Director

National Institute of Standards
and Technology
Technical Note 1265
Natl. Inst. Stand. Technol.
Tech. Note 1265
190 pages (Aug. 1990)
CODEN: NTNOEF

U.S. Government Printing Office
Washington: 1990

For sale by the Superintendent
of Documents
U.S. Government Printing Office
Washington, DC 20402

ACKNOWLEDGMENTS

The authors gratefully acknowledge the assistance of Mr. Gregory F. Strouse in providing some of the figures and tables and the reports of calibration for SPRTs, and the assistance of Mr. George W. Burns, Mr. Earl R. Pfeiffer and Miss Jacquelyn A. Wise in providing copies of reports of calibration for thermocouples, RIRTs, and liquid-in-glass thermometers, respectively.

Table of Contents

	page
List of Tables	ix
List of Figures	x
Abstract	xiii
Scope	xiii
1. Introduction	1
2. Definition of the ITS-90	3
2.1 Between 0.65 K and 5.0 K , ³ He and ⁴ He vapor-pressure thermometry	6
2.2 Between 3.0 K and 24.5561 K (the triple point of Ne), ³ He and ⁴ He constant volume gas thermometry	10
2.3 Between 13.8033 K (the triple point of equilibrium hydrogen) and 1234.93 K (the freezing point of silver), platinum resistance thermometry	11
2.3.1 General relation between resistance ratios and T_{90}	11
2.3.2 SPRT specifications	12
2.3.3 Range 13.8033 K to 273.16 K	14
2.3.3.1 Subrange 24.5561 K to 273.16 K	16
2.3.3.2 Subrange 54.3584 K to 273.16 K	16
2.3.3.3 Subrange 83.8058 K to 273.16 K	16
2.3.4 Range 273.15 K (0 °C) to 1234.93 K (961.78 °C)	17
2.3.4.1 Subrange 273.15 K (0 °C) to 933.473 K (660.323 °C, freezing point of aluminum)	18
2.3.4.2 Subrange 273.15 K (0 °C) to 692.677 K (419.527 °C, freezing point of zinc)	18
2.3.4.3 Subrange 273.15 K (0 °C) to 505.078 K (231.928 °C, freezing point of tin)	18
2.3.4.4 Subrange 273.15 K (0 °C) to 429.7485 K (156.5985 °C, freezing point of indium)	18
2.3.4.5 Subrange 273.15 K (0 °C) to 302.9146 K (29.7646 °C, melting point of gallium)	19
2.3.5 Subrange 234.3156 K (-38.8344 °C, triple point of mercury) to 302.9146 K (29.7646 °C, the melting point of gallium)	19
2.4 Above 1234.93 K (961.78 °C, freezing point of silver); radiation thermometry based on Planck's Law of Radiation	19
3. Realization of the ITS-90	20
3.1 Vapor pressure thermometry and gas thermometry	20
3.1.1 Realization of the ITS-90 below 273.16 K	20
3.1.2 Vapor pressure thermometry and the CVGT range	20
3.1.3 Realization of the vapor-pressure and CVGT scales at temperatures below the neon triple point	22
3.1.3.1 ³ He vapor pressure measurements	23
3.1.3.2 ⁴ He vapor pressure measurements	24

Table of Contents (continued)

	page	
3.1.3.3	e-H ₂ vapor pressure measurements	24
3.1.3.4	Constant volume gas thermometry	24
3.1.3.5	Pressure measurements	26
3.2	Realization of the fixed points of the ITS-90	28
3.2.1	Effect of impurities	28
3.2.2	Triple points of e-H ₂ , Ne, O ₂ , and Ar	29
3.2.2.1	General consideration of apparatus design	29
3.2.2.2	Realizations of the triple points and their application to calibration	33
3.2.3	Triple point of water, 273.16 K (0.01 °C)	36
3.2.3.1	Realization and application of the triple point of water	37
3.2.4	Freezing, melting, or triple points of metals: Hg, Ga, In, Sn, Zn, Al, Ag, Au, or Cu	39
3.2.4.1	Container material	42
3.2.4.2	Metal fixed point devices for calibrating SPRTs	42
3.2.5	Control charts of check thermometers	59
3.3	Radiation thermometry	60
4.	Calibration of thermometers on the ITS-90 at various levels of uncertainty and some approximations of the scale	61
4.1	Rhodium-iron resistance thermometers	63
4.2	Germanium resistance thermometers	64
4.3	Standard platinum resistance thermometers	64
4.3.1	Capsule SPRTs [13.8033 K to 429.7485 K or 505.078 K]	64
4.3.2	Long-stem type SPRTs (83.8058 K to 1234.93 K)	64
4.3.3	Conversion of the IPTS-68 constants and $W(T_{68})$ tables to approximate ITS-90 constants and $W(T_{90})$ tables	65
4.3.4	Uncertainties of calibrations and their propagation	69
4.3.5	Estimates of possible errors introduced by extrapolations beyond the range of calibration	70
4.4	Thermocouples (77 K to 2400 K)	78
4.5	Liquid-in-glass thermometers	78
4.6	Industrial platinum resistance thermometers	78
4.7	Thermistor thermometers, digital thermometers, and other types of thermometers	79
4.8	The logo of the National Conference of Standards Laboratories for the ITS-90.....	80
5	References	82

Table of Contents (continued)

	page
6. Appendices	90
6.1 Copies of, or excerpts from, some papers related to the work of the international bodies concerned with the ITS-90	90
6.1.1 Reproduction of the article by H. Preston-Thomas, entitled, "The International Temperature Scale of 1990," published in <i>Metrologia</i> 27, 3-10 (1990), with corrections	90
6.1.2 Reproduction of the article by T. J. Quinn, entitled "News from the BIPM", published in <i>Metrologia</i> 26, 69-74 (1989)	99
6.1.3 Recommendations adopted by the CCT at its 17th Session	106
6.1.3.1 Recommendation T1 (1989), The International Temperature Scale of 1990	106
6.1.3.2 Recommendation T2 (1989), Reference tables for thermocouples and industrial platinum resistance thermometers	107
6.1.3.3 Recommendation T3 (1989), The uncertainty inherent in the realization of the International Temperature Scale of 1990	107
6.1.4 Reproduction of article by B. W. Mangum, entitled "Special Report on the International Temperature Scale of 1990; Report on the 17th Session of the Consultative Committee on Thermometry," published in <i>J. Res. Natl. Inst. Stand. Technol.</i> 95, 69-77 (1990)	108
6.2 Excerpts from proceedings of some meetings of the CIPM and of the CGPM that are related to the designation of the size of the kelvin and to the ITS-90	118
6.2.1 Recommendation of the CIPM that the numerical value of 273.16 °K, exactly, be assigned to the triple point of water on the thermodynamic scale, excerpted from <i>Procès-Verbaux des Séances, Deuxième Series, Tome XXIV, Session de 1954 du Comité International des Poids et Mesures</i> , published by Gauthier Villars, Editeur-Imprimeur-Libraire, Paris, 1955	118
6.2.2 Definition of the thermodynamic scale of temperature. This entails the assignment of the value 273.16 °K, exactly, to the triple point of water as a fundamental fixed point, excerpted from <i>Comptes Rendus des Séances, Dixième Conférence Générale des Poids et Mesures, Reunie à Paris en 1954</i> , published by Gauthier Villars, Editeur-Imprimeur-Libraire, Editeur du Bureau International des Poids et Mesures, Paris, 1955	118

Table of Contents (continued)

	page
6.2.3	Recommendations of the CCT, concerning the development of the ITS-90 and simplified methods of its realization, that were presented to the CIPM on 9 July 1987, excerpted from Procès-Verbaux des Séances du Comité International des Poids et Mesures, Procès-Verbaux de la 76 ^e session - 1987, Tome 55, Édité par le BIPM, Pavillon de Breteuil, F-92312 Sèvres Cedex, France 119
6.2.4	The resolution, instructing the CIPM to develop the ITS-90, adopted by the 18th CGPM in 1987, and excerpted from Comptes Rendus, 18 ^e Conférence Générale des Poids et Mesures (1987), Édité par le BIPM, Pavillon de Breteuil, F-92312 Sèvres Cedex, France 121
6.3	Examples of some typical Report of Calibration documents from the NIST Calibration Laboratories for thermometers calibrated over various ranges 122
6.3.1	Example of a Report of Calibration for an SPRT calibrated over the range from 13.8033 K to 302.9146 K 122
6.3.2	Example of a Report of Calibration for an SPRT calibrated over the range from 83.8058 K to 933.473 K 126
6.3.3	Example of a Report of Calibration for an SPRT calibrated over the range from 273.15 K to 1234.93 K 129
6.3.4	Example of a Report giving the T_{68} to T_{90} conversion for a long-stem type SPRT calibrated on the IPTS-68(75) from the oxygen condensation point to the freezing point of zinc 132
6.3.5	Example of a Report giving the T_{68} to T_{90} conversion for a capsule-type SPRT calibrated on the IPTS-68(75) from the triple point of equilibrium hydrogen to the freezing point of tin 135
6.3.6	Example of a Report of Calibration for an RIRT calibrated over the range from 0.50 K to 30 K on the EPT-76 138
6.3.7	Example of a Report of Calibration for an RIRT (the RIRT of sec. 6.3.6) calibrated over the range from 0.65 K to 25 K on the ITS-90 147
6.3.8	Example of a Report of Calibration for a thermocouple calibrated over the range from 0 °C to 1450 °C 154
6.3.9	Example of a Report of Calibration for a liquid-in-glass thermometer calibrated over the range from 0 °C to 100 °C on the IPTS-68(75) 162

Table of Contents (continued)

	page
6.3.10 Example of a Report of Calibration for the liquid-in-glass thermometer of section 6.3.9 calibrated over the range from 0 °C to 100 °C on the IPTS-68(75) but converted to the ITS-90	164
6.4 The National Conference of Standard Laboratories (NCSL) Ad Hoc Committee (91.3) on the Change in the International Temperature Scale that was formed to publicize the ITS-90 and its implementation and to minimize the confusion and inconvenience of the change from the IPTS-68(75)	166
7. NIST Calibration Services, Thermometers	167
7.1 Laboratory Thermometers	167
7.2 Thermocouples, Thermocouple Materials, and Pyrometer Indicators	169
7.3 Resistance Thermometers	173

List of Tables

	page
Table 1. Differences between T_{90} and T_{68} (and t_{90} and t_{68}), and between T_{90} and T_{76}	5
Table 2. Defining fixed points of the ITS-90	8
Table 3. Comparison of temperatures of fixed points assigned on various scales.	9
Table 4. Values of the coefficients A_i and of the constants B and C for the ^3He and ^4He vapor pressure equations and the temperature range for which each equation is valid	10
Table 5. Values of the coefficients A_i , B_i , C_i and D_i and of the constants A_0 , B_0 , C_0 , and D_0 in the reference functions, equations (14) and (22), and in the functions approximating them, given by equations (15) and (23)	15
Table 6. The effect of pressure on the temperatures of the defining fixed points. The reference pressure for the equilibrium states of freezing and melting points is one standard atmosphere (101,325 Pa). Triple points have the vapor pressure of the material when the solid, liquid and vapor phases are present in equilibrium	25
Table 7. Latent heats of fusion and first cryoscopic constants of defining fixed-point materials	29
Table 8. Example of conversion of calibrations of SPRTs on the IPTS-68 to approximate calibrations on the ITS-90	66
Table 9. Values of $W(T_{68})$ and $W(T_{90})$ for various fixed-point temperatures T_{68} and T_{90} , respectively	67
Table 10. Example of a conversion of calibration values of a type K thermocouple on the IPTS-68 to an approximate calibration on the ITS-90	79

List of Figures

		Page
Figure 1.	The temperature difference ($t_{90} - t_{68}$)/°C in the range between the triple point of equilibrium hydrogen (-259.3467 °C) and the freezing point of gold (1337.33 °C)	4
Figure 2.	A schematic representation of the ITS-90 showing the temperatures of the defining fixed points (or phase equilibrium states) on the scale and temperature ranges defined by interpolation instruments and equations ...	7
Figure 3.	A schematic representation of the ITS-90 in the range specified for the platinum resistance thermometer, showing the various defined subranges and the temperatures of the defining fixed points on the scale required for calibration	13
Figure 4.	A schematic drawing of the NIST argon triple-point apparatus for calibrating seven long-stem SPRTs and six capsule SPRTs	30
Figure 5.	A sealed cell suitable for containing cryogenic gases at high pressures	31
Figure 6.	Two types of triple point of water cells with wells for platinum resistance thermometers	35
Figure 7.	An SPRT in a Type A triple point of water cell immersed in an ice bath	38
Figure 8.	Idealized liquid/solid equilibrium conditions inside fixed point cells used in freezing and melting experiments	40
Figure 9.	An SPRT in a metal freezing-point cell	41
Figure 10.	Two mercury triple-point cells, one constructed of borosilicate glass and one of Type 304 stainless steel	43
Figure 11.	A borosilicate glass, mercury triple-point cell in a stainless steel container	45
Figure 12.	Photograph of an all-plastic indium cell and its stainless steel container	46
Figure 13.	An all-plastic gallium melting/triple-point cell	48

List of Figures (continued)

	Page
Figure 14. An all-plastic indium freezing-point cell to be used in a stainless steel container, such as that shown in figure 12	50
Figure 15. A graphite freezing point cell enclosed inside a fused silica tube with tube connection to high vacuum, purified argon gas source, and pressure gauge	53
Figure 16. A method for filling a graphite freezing-point cell by melting the metal sample in the graphite crucible	55
Figure 17. An apparatus for installing a graphite thermometer well and lid in a graphite crucible containing a molten metal sample	56
Figure 18. Differences between T_{90} and $(T_{90})_{as}$ calculated from IPTS-68 calibration for the long-stem SPRT, S/N RS8YA-5, of table 8	68
Figure 19. Propagation of errors from errors of calibration of SPRTs between 13.8033 K and 273.16 K	71
Figure 20. Propagation of errors from errors of calibration of SPRTs between 273.15 K and 1234.93 K. Also included in this figure are error curves for errors made by the user at the triple point of water	72
Figure 21. Curve for a NIST SPRT that shows the error introduced by extrapolating the deviation function, determined from calibration over the range from the triple point of argon to the triple point of water, downward from the triple point of argon to 54 K	73
Figure 22. Curve for a NIST SPRT that shows the error introduced by extrapolating its deviation function, determined from calibration over the range from the triple point of mercury to the melting point of gallium, downward from the triple point of mercury to 84 K	74
Figure 23. Curve for the NIST SPRT of figure 22 that shows the error introduced by extrapolating its deviation function, determined from calibration over the range from the triple point of mercury to the melting point of gallium, downward from the triple point of mercury to only 200 K	75

List of Figures (continued)

	Page
Figure 24. Curves for several NIST SPRTs that show the errors introduced by extrapolating their deviation functions, determined from calibration over the range from the triple point of water to the freezing point of zinc, downward from the triple point of water to -50 °C	76
Figure 25. Curves for several NIST SPRTs that show the errors introduced by extrapolating their deviation functions, determined from calibration over the range from the triple point of water to the freezing point of zinc, upward from the freezing point of zinc to 934 K (660 °C). Also shown are subrange inconsistencies for the subrange triple point of water to zinc, relative to the subrange triple point of water to aluminum	77
Figure 26. The NCSL ITS-90 logo	81

ABSTRACT

This Technical Note describes the International Temperature Scale of 1990 (ITS-90) that became the official international temperature scale on 1 January 1990, superseding the previous scales, and provides information on how the scale may be realized at different levels of accuracy. The ITS-90 extends upward from 0.65 K, is in close agreement with the Kelvin Thermodynamic Temperature Scale, has much improved continuity, precision and reproducibility throughout its ranges over that of previous scales, and has subranges and alternative definitions in certain ranges that greatly facilitate its use. In addition to a description of the ITS-90 and how it can be realized, there are included in this document reproductions of some articles and excerpts from documents concerned with the ITS-90. The composition of the Comité Consultatif de Thermométrie (CCT) of the Comité International des Poids et Mesures (CIPM) at the time of the adoption of the ITS-90 is given. The differences between the temperatures on the ITS-90 and those on the International Practical Temperature Scale of 1968, Amended Edition of 1975, [IPTS-68(75)] and those on the 1976 Provisional 0.5 K to 30 K Temperature Scale (EPT-76) are tabulated. Measurement procedures for realizing the ITS-90 throughout the various ranges of the scale are given. Also, for the most important temperature region, the region of the platinum resistance thermometer (PRT), computational examples are given for determining the coefficients of the relevant deviation equations for PRTs calibrated at various sets of fixed points. The effects of the introduction of the ITS-90 on electrical reference standards are addressed also.

SCOPE

The ITS-90 and, consequently, the topics discussed in this document affect all aspects of thermometry at temperatures from 0.65 K upward. This change of scale will affect principally those making high precision temperature measurements. Thus, all standards and calibration laboratories will be affected and they should implement the ITS-90 as soon as possible.

If the required minimum uncertainty of measurements over a given range of temperature is at least three times as large as the differences between the new and old scales in that range, as given in table 1 and shown in figure 1 of this document, then the effect of the change in scales will be negligible and the user will, for all practical purposes, be unaffected.

DISCLAIMER

Certain commercial equipment, instruments, or materials are identified in this paper in order to adequately specify the experimental procedure. Such identification does not imply recommendation or endorsement by the National Institute of Standards and Technology, nor does it imply that the materials or equipment identified are necessarily the best available for the purpose.

**Guidelines for Realizing the
International Temperature Scale of 1990 (ITS-90)**

B. W. Mangum
National Institute of Standards and Technology
Gaithersburg, MD 20899

and

G. T. Furukawa
Guest Scientist
National Institute of Standards and Technology
Gaithersburg, MD 20899

1. INTRODUCTION

The Comité Consultatif de Thermométrie (CCT) is one of eight specialized technical subcommittees of the Comité International des Poids et Mesures (CIPM). The CIPM is a committee of the Conférence Générale des Poids et Mesures (CGPM). These eight subcommittees are:

1. The Comité Consultatif d'Électricité (CCE), established in 1927,
2. The Comité Consultatif de Photométrie et Radiométrie (CCPR), assigned this name in 1971; the previous name was the Comité Consultatif de Photométrie, established in 1933,
3. The Comité Consultatif de Thermométrie (CCT), established in 1937,
4. The Comité Consultatif pour la Définition du Mètre (CCDM), established in 1952,
5. The Comité Consultatif pour la Définition de la Seconde (CCDS), established in 1956,
6. The Comité Consultatif pour les Étalons de Mesure des Rayonnements Ionisants (CCEMRI), established in 1958,
7. The Comité Consultatif des Unités (CCU), established in 1964, and
8. The Comité Consultatif pour la Masse et les grandeurs apparentées (CCM), established in 1980.

The CCT is composed presently of members from the following laboratories:

1. Amt für Standardisierung, Messwesen und Warenprüfung [ASMW], Berlin, DDR,
2. Bureau National de Métrologie, Paris, France : Institut National de Métrologie [INM], du Conservatoire National des Arts et Métiers,
3. Ceskoslovensky Metrologický Ustav [CSMU], Bratislava, Czechoslovakia,
4. National Research Council [NRC], Ottawa, Canada,
5. CSIRO, Division of Applied Physics [CSIRO], Lindfield, Australia,
6. D.I. Mendeleev Institute for Metrology [VNIIM], Leningrad, USSR; Physico-Technical and Radio-Technical Measurements Institute [PRMI], Moscow, USSR,
7. National Institute of Metrology [NIM], Beijing, PRC,
8. Istituto di Metrologia G. Colonnetti [IMGC], Turin, Italy,
9. Kamerlingh Onnes Laboratorium [KOL], Leiden, The Netherlands,
10. Korea Standards Research Institute [KSRI], Seoul, Korea,

11. National Institute of Standards and Technology [NIST], Gaithersburg, MD, USA,
12. National Physical Laboratory [NPL], Teddington, UK,
13. National Research Laboratory of Metrology [NRLM], Ibaraki, Japan,
14. Physikalisch-Technische Bundesanstalt [PTB], Braunschweig, FRG,
15. Van Swinden Laboratorium [VSL], Delft, The Netherlands,
16. Iowa State University, Ames, Iowa, USA, and
17. Bureau International des Poids et Mesures [BIPM], Sèvres, France.

Shortly after the adoption of the International Practical Temperature Scale of 1968 (IPTS-68) [100], it was realized that the scale had many deficiencies and limitations. These included its lower limit of 13.81 K, its inaccuracy relative to thermodynamic temperatures, and its non-uniqueness and irreproducibility, especially in the temperature region from $T_{68} = 903.89$ K (630.74 °C) to $T_{68} = 1337.58$ K (1064.43 °C), the region in which the Pt-10%Rh/Pt thermocouple was the standard interpolating instrument. Consequently, the CCT undertook the development of a new scale, and completed it in accordance with Resolution 7 of the 18th Conférence Générale des Poids et Mesures [29], which met in October 1987 (see appendices).

The CCT met 12-14 September 1989 at the Bureau International des Poids et Mesures (BIPM) in its 17th Session [14] and completed the final details of the new temperature scale, the International Temperature Scale of 1990 (ITS-90) [66,83]. The CCT then recommended to the CIPM, which met [84] on 26-28 September 1989 at the BIPM, that the ITS-90 be adopted and made the official scale (see appendices). Upon considering this recommendation, the CIPM adopted the new temperature scale (see appendices), and the ITS-90 became the official international temperature scale on 1 January 1990, the same date on which changes affecting certain electrical reference standards were implemented [12]. The ITS-90 supersedes the IPTS-68, the International Practical Temperature Scale of 1968, Amended Edition of 1975 [IPTS-68(75)] [101], and the 1976 Provisional 0.5 K to 30 K Temperature Scale (EPT-76) [99].

The ITS-90 was implemented at the NIST on 1 January 1990. The purpose of this document is to describe the new scale, to give some guidelines for its realization and use, to facilitate its implementation, to give the differences between temperatures on it and those on the IPTS-68(75) and on the EPT-76, and to describe how the NIST realizes the scale.

The ITS-90 extends upward from 0.65 K and temperatures on this scale are in much better agreement with thermodynamic values than are those on the IPTS-68(75) and the EPT-76. The new scale has subranges and alternative definitions in certain ranges that greatly facilitate its use. Furthermore, its continuity, non-uniqueness and reproducibility throughout its ranges are much improved over the corresponding characteristics of the previous scales. The biggest improvement in reproducibility results from the replacement of thermocouple thermometry with platinum resistance thermometry in the range 630 °C to the freezing-point temperature of silver, and with radiation thermometry in the range from the freezing-point temperature of silver to that of gold.

The change in the temperature scale affects not only technical interests involved directly in thermometry but also those involved with other reference standards,

such as electrical standards, that are sensitive to temperature. As examples, standard resistors and standard cells are sensitive to temperature and generally are maintained in constant-temperature environments, at least in national standards laboratories. At the present time, the temperatures of those environments are normally determined with thermometers that were calibrated on the IPTS-68(75). A given thermodynamic temperature expressed on the ITS-90, however, has a value that is different from that expressed on the IPTS-68(75), except at absolute zero (0 K), at the triple-point temperature of water (273.16 K), and at a few other points at which the temperatures on the two scales are fortuitously the same. This difference is shown in figure 1 [83]. A table of differences between temperatures on the ITS-90, i.e., T_{90} or t_{90} , and those on the IPTS-68(75), i.e., T_{68} or t_{68} , and those on the EPT-76, T_{76} , is given in the text of the ITS-90 and is presented here in table 1. Although temperature values expressed on the two scales are different, the change is only in the expression of the value of temperature and not in the temperature itself. That is to say, the Kelvin thermodynamic temperature (the hotness) of a material at any given point is independent of the use of any of the 'practical' temperature scales. The better the 'practical' scale is, the closer the values of temperature on that scale are to the thermodynamic temperature values. Needless to say, the Kelvin thermodynamic temperature values are experimentally determined, and they may have significant error. Since temperature values expressed on the thermodynamic and 'practical' scales are different, if the temperature of the environment of a reference standard is adjusted so that its value when expressed on the ITS-90 has the same value as had been used on the IPTS-68(75), there will have been a change of the thermodynamic temperature and the value of the reference standard will usually change. Of course, one may not want to change the thermodynamic temperature of the reference standard. In that case, the thermodynamic temperature, as expressed on the IPTS-68(75), can simply be expressed on the ITS-90 (a numerical value different from that on the IPTS-68(75)) and the reference standards will be unaffected. For more details on the effects of the change of the temperature scale on electrical standards, see National Institute of Standards and Technology (NIST) Technical Note 1263 [12].

In addition to the effect on reference standards for measurements, all temperature-sensitive properties, e.g., tables of thermodynamic properties, that are presently expressed on the IPTS-68(75) may require changes in values.

2. DEFINITION OF THE ITS-90

The ITS-90 was designed by the CCT in such a manner that temperature values obtained on it do not deviate from the Kelvin thermodynamic temperature values by more than the uncertainties of the latter values at the time the ITS-90 was adopted. Thermodynamic temperature is indicated by the symbol T and has the unit known as the kelvin, symbol K. The size of the kelvin is defined to be $1/273.16$ of the thermodynamic temperature of the triple point of water. This definition of the Kelvin Thermodynamic Temperature Scale (KTTS) that is based on the value of a single finite temperature is not new; the CCT proposed it in 1954, the CIPM recommended it, and the Tenth CGPM adopted it that same year [30].

Because temperatures on previous temperature scales were expressed relative to the ice point (273.15 K), temperature, symbol t , on the Celsius Temperature Scale is defined by:

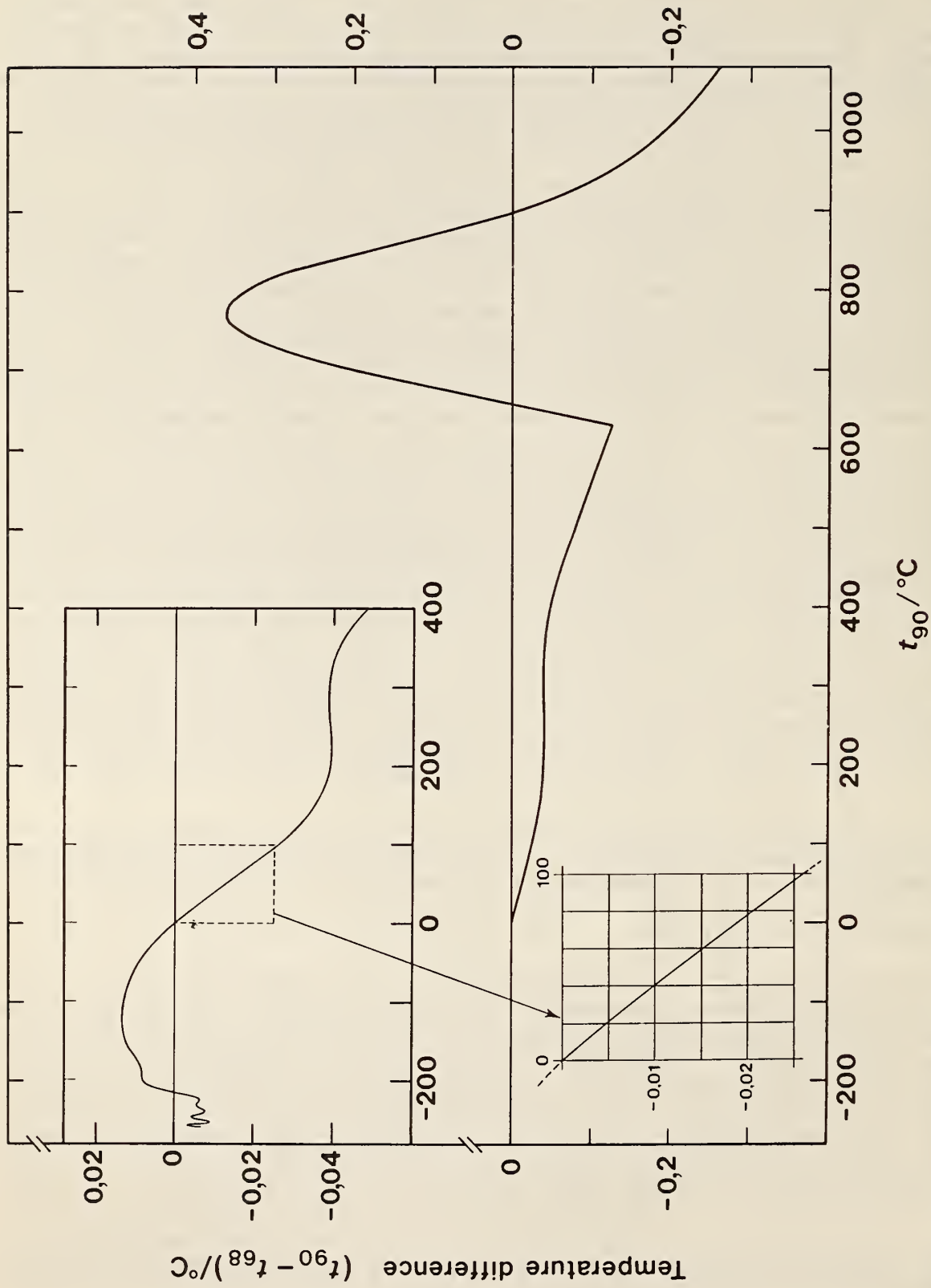

Figure 1. The temperature difference ($t_{90} - t_{68}$)/°C in the range between the triple point of equilibrium hydrogen (-259.3467 °C) and the freezing point of gold (1064.18 °C) [83, 85].

Table 1. Differences between T_{90} and T_{68} (and t_{90} and t_{68}), and between T_{90} and T_{76}

$(T_{90} - T_{76})/\text{mK}$										
T_{90}/K	0	1	2	3	4	5	6	7	8	9
0						-0.1	-0.2	-0.3	-0.4	-0.5
10	-0.6	-0.7	-0.8	-1.0	-1.1	-1.3	-1.4	-1.6	-1.8	-2.0
20	-2.2	-2.5	-2.7	-3.0	-3.2	-3.5	-3.8	-4.1		
$(T_{90} - T_{68})/\text{K}$										
T_{90}/K	0	1	2	3	4	5	6	7	8	9
10					-0.006	-0.003	-0.004	-0.006	-0.008	-0.009
20	-0.009	-0.008	-0.007	-0.007	-0.006	-0.005	-0.004	-0.004	-0.005	-0.006
30	-0.006	-0.007	-0.008	-0.008	-0.008	-0.007	-0.007	-0.007	-0.006	-0.006
40	-0.006	-0.006	-0.006	-0.006	-0.006	-0.007	-0.007	-0.007	-0.006	-0.006
50	-0.006	-0.005	-0.005	-0.004	-0.003	-0.002	-0.001	0.000	0.001	0.002
60	0.003	0.003	0.004	0.004	0.005	0.005	0.006	0.006	0.007	0.007
70	0.007	0.007	0.007	0.007	0.007	0.008	0.008	0.008	0.008	0.008
80	0.008	0.008	0.008	0.008	0.008	0.008	0.008	0.008	0.008	0.008
90	0.008	0.008	0.008	0.008	0.008	0.008	0.008	0.009	0.009	0.009
T_{90}/K	0	10	20	30	40	50	60	70	80	90
100	0.009	0.011	0.013	0.014	0.014	0.014	0.014	0.013	0.012	0.012
200	0.011	0.010	0.009	0.008	0.007	0.005	0.003	0.001		
$(t_{90} - t_{68})/^{\circ}\text{C}$										
$t_{90}/^{\circ}\text{C}$	0	-10	-20	-30	-40	-50	-60	-70	-80	-90
-100	0.013	0.013	0.014	0.014	0.014	0.013	0.012	0.010	0.008	0.008
0	0.000	0.002	0.004	0.006	0.008	0.009	0.010	0.011	0.012	0.012
$t_{90}/^{\circ}\text{C}$	0	10	20	30	40	50	60	70	80	90
0	0.000	-0.002	-0.005	-0.007	-0.010	-0.013	-0.016	-0.018	-0.021	-0.024
100	-0.026	-0.028	-0.030	-0.032	-0.034	-0.036	-0.037	-0.038	-0.039	-0.039
200	-0.040	-0.040	-0.040	-0.040	-0.040	-0.040	-0.040	-0.039	-0.039	-0.039
300	-0.039	-0.039	-0.039	-0.040	-0.040	-0.041	-0.042	-0.043	-0.045	-0.046
400	-0.048	-0.051	-0.053	-0.056	-0.059	-0.062	-0.065	-0.068	-0.072	-0.075
500	-0.079	-0.083	-0.087	-0.090	-0.094	-0.098	-0.101	-0.105	-0.108	-0.112
600	-0.115	-0.118	-0.122	-0.125	-0.08	-0.03	0.02	0.06	0.11	0.16
700	0.20	0.24	0.28	0.31	0.33	0.35	0.36	0.36	0.36	0.35
800	0.34	0.32	0.29	0.25	0.22	0.18	0.14	0.10	0.06	0.03
900	-0.01	-0.03	-0.06	-0.08	-0.10	-0.12	-0.14	-0.16	-0.17	-0.18
1000	-0.19	-0.20	-0.21	-0.22	-0.23	-0.24	-0.25	-0.25	-0.26	-0.26
$t_{90}/^{\circ}\text{C}$	0	100	200	300	400	500	600	700	800	900
1000		-0.26	-0.30	-0.35	-0.39	-0.44	-0.49	-0.54	-0.60	-0.66
2000	-0.72	-0.79	-0.85	-0.93	-1.00	-1.07	-1.15	-1.24	-1.32	-1.41
3000	-1.50	-1.59	-1.69	-1.78	-1.89	-1.99	-2.10	-2.21	-2.32	-2.43

$$t/^{\circ}\text{C} = T/\text{K} - 273.15. \quad (1)$$

The unit of temperature t is the degree Celsius, symbol $^{\circ}\text{C}$, and it is by definition the same size as the kelvin. A difference of temperature may be expressed either in kelvins or in degrees Celsius.

Temperatures on the ITS-90 are expressed, in terms of the International Kelvin Temperatures, with the symbol T_{90} , or, in terms of the International Celsius Temperatures, with the symbol t_{90} . The unit of the temperature T_{90} is the kelvin, symbol K, and the unit of the temperature t_{90} is the degree Celsius, symbol $^{\circ}\text{C}$. The relation between T_{90} and t_{90} is:

$$t_{90}/^{\circ}\text{C} = T_{90}/\text{K} - 273.15. \quad (2)$$

The ITS-90 extends upward from 0.65 K. There are alternative definitions of T_{90} in certain temperature ranges and they have equal status. In measurements of the highest precision made at the same temperature, the alternative definitions will yield detectable temperature differences. Also, at any given temperature between defining fixed points, different interpolating thermometers that meet the specifications of the ITS-90 will indicate different temperature values. These latter differences are referred to as the non-uniqueness in the definition of the ITS-90. The magnitude of the differences that result from these two sources is sufficiently small to be negligible for all practical purposes.

Temperatures on the ITS-90 are defined in terms of equilibrium phase states of pure substances (defining fixed points), interpolating instruments, and equations that relate the measured property of the instruments to T_{90} . The equilibrium phase states of the pure substances and the assigned temperatures used as defining fixed points of the ITS-90 are listed in table 2. Figure 2 shows schematically the defining phase states and temperature ranges defined by the various interpolating instruments and equations. For comparison purposes, we give in table 3 the defining fixed points, and their assigned temperatures, of the ITS-90 and of all the previous internationally agreed-upon scales.

2.1 BETWEEN 0.65 K AND 5.0 K: ^3He and ^4He VAPOR PRESSURE THERMOMETRY

The ITS-90 is defined between 0.65 K and 3.2 K by the vapor-pressure-temperature relation of ^3He , and between 1.25 K and 2.1768 K (the λ point) and between 2.1768 K and 5.0 K by the vapor-pressure-temperature relations of ^4He . T_{90} is defined by the vapor-pressure equations of the form:

$$T_{90}/\text{K} = A_0 + \sum_{i=1}^9 A_i \{ [\ln(p/\text{Pa}) - B]/C \}^i. \quad (3)$$

The values of the coefficients A_i and of the constants A_0 , B and C of the vapor-pressure equations for ^3He and ^4He are given in table 4.

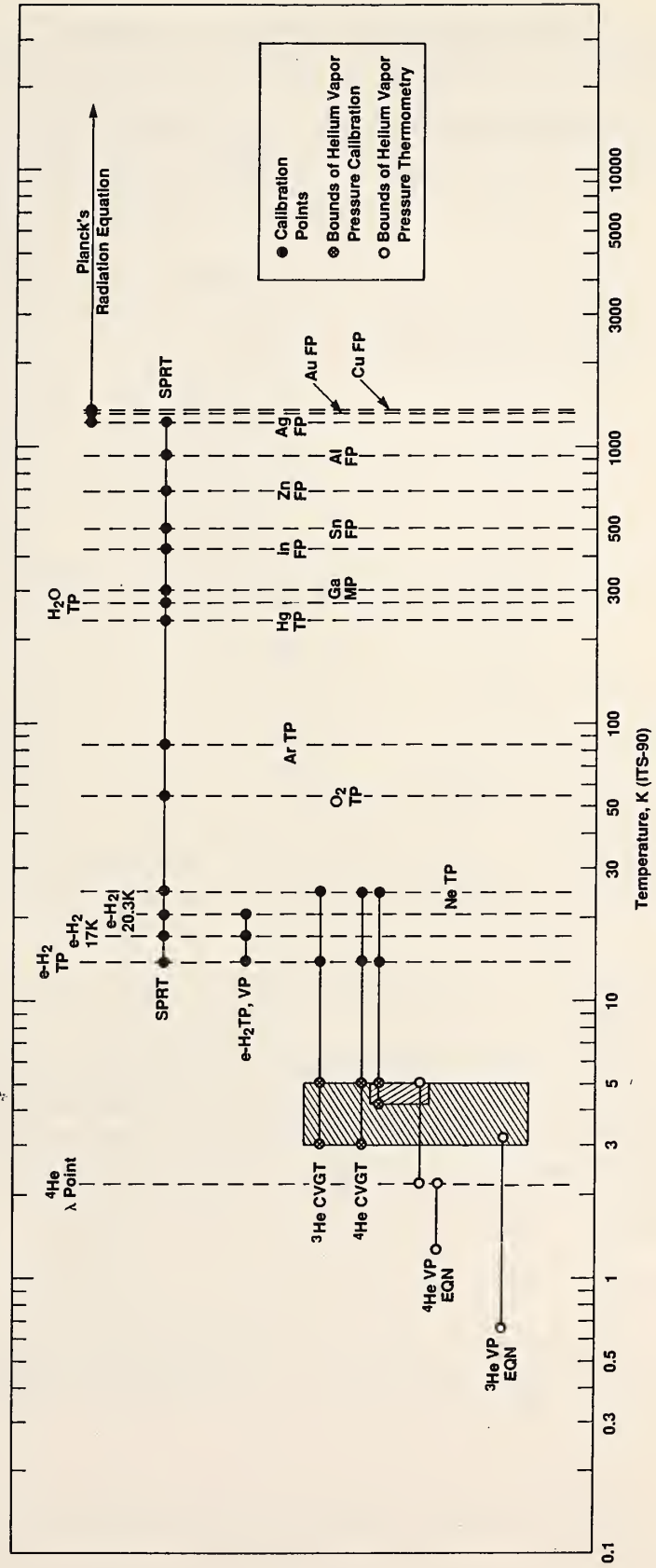

Figure 2. A schematic representation of the ITS-90 showing the temperatures of the defining fixed points (or phase equilibrium states) on the scale and temperature ranges defined by interpolation instruments and equations.

Table 2. Defining fixed points of the ITS-90

Material ^a	Equilibrium State ^b	Temperature		$W_r(T_{90})^e$
		T_{90} (K)	t_{90} (°C)	
He	VP	3 to 5	- 270.15 to - 268.15	
e-H ₂	TP	13.8033	- 259.3467	0.00119007
e-H ₂ (or He)	VP (or CVGT)	≈ 17	≈ - 256.15	
e-H ₂ (or He)	VP (or CVGT)	≈ 20.3	≈ - 252.85	
Ne ^c	TP	24.5561	- 248.5939	0.00844974
O ₂	TP	54.3584	- 218.7916	0.09171804
Ar ^d	TP	83.8058	- 189.3442	0.21585975
Hg ^c	TP	234.3156	- 38.8344	0.84414211
H ₂ O	TP	273.16	0.01	1.00000000
Ga ^c	MP	302.9146	29.7646	1.11813889
In ^c	FP	429.7485	156.5985	1.60980185
Sn ^d	FP	505.078	231.928	1.89279768
Zn	FP	692.677	419.527	2.56891730
Al ^c	FP	933.473	660.323	3.37600860
Ag	FP	1234.93	961.78	4.28642053
Au	FP	1337.33	1064.18	
Cu ^c	FP	1357.77	1084.62	

^a e-H₂ indicates equilibrium hydrogen, that is, hydrogen with the equilibrium distribution of its ortho and para states at the corresponding temperatures. Normal hydrogen at room temperature contains 25% para and 75% ortho hydrogen.

^b VP indicates vapor pressure point or equation; CVGT indicates constant volume gas thermometer point; TP indicates triple point (equilibrium temperature at which the solid, liquid and vapor phases coexist); FP indicates freezing point and MP indicates melting point (the equilibrium temperatures at which the solid and liquid phases coexist under a pressure of 101,325 Pa, one standard atmosphere). The isotopic composition is that naturally occurring.

^c Previously, these were secondary fixed points.

^d Previously, these were alternative fixed points.

^e From reference functions, eqs (14) and (22).

Table 3. Comparison of temperatures of fixed points assigned on various scales. Temperatures are expressed in kelvins on the KTS or equivalent scales

Point	NHS ^a	ITS-27 ^b	ITS-48 ^b	IPTS-48 ^b	IPTS-68	IPTS-68(75)	EPT-76	ITS-90
Au FP ^c	-	1336.15	1336.15	1336.15	1337.58	1337.58	-	1337.33
Ag FP	-	1233.65	1233.95	1233.95	1235.08	1235.08	-	1234.93
Al FP	-	-	-	-	-	-	-	933.473
S BP ^d	-	717.75	717.75	717.75	-	-	-	-
Zn FP	-	-	-	(692.655)	692.73	692.73	-	692.677
Sn FP	-	-	-	-	(505.1181)	(505.1181)	-	505.078
In FP	-	-	-	-	-	-	-	429.7485
H ₂ O BP	373	373.15	373.15	373.15	373.15	373.15	-	-
Ga TP	-	-	-	-	-	-	-	302.9146
H ₂ O TP ^e	-	-	-	(273.16)	273.16	273.16	-	273.16
H ₂ O FP	273	273.15	273.15	-	-	-	-	-
Hg TP	-	-	-	-	-	-	-	234.3156
O ₂ BP ^f	-	90.18	90.18	90.18	90.188	90.188	-	-
Ar TP	-	-	-	-	-	(83.798)	-	83.8058
O ₂ TP	-	-	-	-	54.361	54.361	-	54.3584
Ne BP	-	-	-	-	27.102	27.102	21.102	-
Ne TP	-	-	-	-	-	-	24.5591	24.5561
H ₂ BP	-	-	-	-	20.28	20.28	20.2734	20.3
H ₂ BP ^g	-	-	-	-	17.042	17.042	17.0373	17.0
H ₂ TP	-	-	-	-	13.81	13.81	13.8044	13.8033
Pb SP ^h	-	-	-	-	-	-	7.1999	-
⁴ He BP	-	-	-	-	-	-	4.2221	4.2
In SP	-	-	-	-	-	-	3.4145	-
³ He BP	-	-	-	-	-	-	-	3.2
Al SP	-	-	-	-	-	-	1.1796	-
Zn SP	-	-	-	-	-	-	0.851	-
Cd SP	-	-	-	-	-	-	0.519	-

^a NHS = Normal hydrogen scale [25].

^b For a time, the ice point was taken to be 273.16 °K. Here, the value 273.15 K was used to convert temperature values in degrees Centigrade or Celsius to kelvins in order to be as consistent as possible throughout the table.

^c FP = Freezing point.

^d BP = Boiling point at 101,325 Pa.

^e TP = Triple point.

^f Changed in 1975 to the condensation point.

^g Reduced-pressure boiling point, at P = 33,330.6 Pa.

^h SP = Superconductive transition point.

Table 4. Values of the coefficients A_i and of the constants B and C for the ^3He and ^4He vapor-pressure equations and the temperature range for which each equation is valid

Coef. or Constant	^3He	^4He	^4He
	0.65 K to 3.2 K	1.25 K to 2.1768 K	2.1768 K to 5.0 K
A_0	1.053 447	1.392 408	3.146 631
A_1	0.980 106	0.527 153	1.357 655
A_2	0.676 380	0.166 756	0.413 923
A_3	0.372 692	0.050 988	0.091 159
A_4	0.151 656	0.026 514	0.016 349
A_5	-0.002 263	0.001 975	0.001 826
A_6	0.006 596	-0.017 976	-0.004 325
A_7	0.088 966	0.005 409	-0.004 973
A_8	-0.004 770	0.013 259	0
A_9	-0.054 943	0	0
B	7.3	5.6	10.3
C	4.3	2.9	1.9

2.2 BETWEEN 3.0 K AND 24.5561 K (THE TRIPLE POINT OF Ne): ^3He and ^4He CONSTANT VOLUME GAS THERMOMETRY

Between 3.0 K and 24.5561 K, the ITS-90 is defined in terms of the ^3He or ^4He constant volume gas thermometer (CVGT). The thermometer is calibrated at three temperatures – at the triple point of neon (24.5561 K), at the triple point of equilibrium hydrogen (13.8033 K), and at a temperature between 3.0 K and 5.0 K, the value of which is determined by using either a ^3He or a ^4He vapor-pressure thermometer as described in section 2.1.

For a ^4He CVGT that is used between 4.2 K and the triple point of neon (24.5561 K), T_{90} is defined by the equation:

$$T_{90} = a + bp + cp^2, \quad (4)$$

where p is the CVGT pressure and a , b , and c are coefficients that are determined from calibrations at the three specified temperatures, but with the additional requirement that the calibration with the vapor-pressure thermometer be made at a temperature between 4.2 K and 5.0 K.

For a ^4He CVGT that is used between 3.0 K and 4.2 K, and for a ^3He CVGT that is used between 3.0 K and 24.5561 K, the non-ideality of the gas must be accounted for, using the respective second virial coefficients, $B_4(T_{90})$ or $B_3(T_{90})$. T_{90} is defined in this range by the equation:

$$T_{90} = \frac{a + bp + cp^2}{1 + B_x(T_{90})N/V}, \quad (5)$$

where p is the CVGT pressure; a , b , and c are coefficients that are determined from calibration at the three defining temperatures; $B_x(T_{90})$ refers to $B_3(T_{90})$ or $B_4(T_{90})$; and N/V is the gas density, in moles per cubic meter, in the CVGT bulb. The values of the second virial coefficients are given by the following equations:

for ^3He ,

$$B_3(T_{90})/\text{m}^3\text{mol}^{-1} = [16.69 - 336.98 (T_{90}/\text{K})^{-1} + 91.04 (T_{90}/\text{K})^{-2} - 13.82 (T_{90}/\text{K})^{-3}] 10^{-6}, \quad (6)$$

and for ^4He ,

$$B_4(T_{90})/\text{m}^3\text{mol}^{-1} = [16.708 - 374.05 (T_{90}/\text{K})^{-1} - 383.53 (T_{90}/\text{K})^{-2} + 1799.2 (T_{90}/\text{K})^{-3} - 4033.2 (T_{90}/\text{K})^{-4} + 3252.8 (T_{90}/\text{K})^{-5}] 10^{-6}. \quad (7)$$

The accuracy of realization of T_{90} by using a CVGT is dependent upon the CVGT design and the gas density used.

2.3 BETWEEN 13.8033 K (THE TRIPLE POINT OF EQUILIBRIUM HYDROGEN) AND 1234.93 K (THE FREEZING POINT OF SILVER): PLATINUM RESISTANCE THERMOMETRY

Between 13.8033 K (-259.3467 °C) and 1234.93 K (961.78 °C), the ITS-90 is defined in terms of specified fixed points to which temperature values have been assigned, by resistance ratios of platinum resistance thermometers obtained by calibration at specified sets of the fixed points, and by reference functions and deviation functions of resistance ratios which relate to T_{90} between the fixed points. (Henceforth, for convenience, the standards type platinum resistance thermometers will be referred to by the acronym SPRT.)

2.3.1 GENERAL RELATION BETWEEN RESISTANCE RATIOS AND T_{90}

Temperatures on the ITS-90 in the above-indicated range are expressed in terms of the ratio of the resistance $R(T_{90})$ at temperature T_{90} and the resistance $R(273.16 \text{ K})$ at the triple-point temperature of water. (Hereinafter, for convenience, the terms triple-point temperature, freezing-point temperature and melting-point temperature will be expressed as triple point, freezing point and melting point, respectively.) The resistance ratio $W(T_{90})$ is:

$$W(T_{90}) = R(T_{90})/R(273.16 \text{ K}). \quad (8)$$

The temperature T_{90} is calculated from the resistance ratio relation:

$$W(T_{90}) - W_r(T_{90}) = \Delta W(T_{90}), \quad (9)$$

where $W(T_{90})$ is the observed value, $W_r(T_{90})$ is the value calculated from the reference functions, and $\Delta W(T_{90})$ is the deviation of the observed $W(T_{90})$ value of the particular SPRT from the reference function value. The official version of the ITS-90 [83] does not indicate the difference $[W(T_{90}) - W_r(T_{90})]$ by $\Delta W(T_{90})$.

Note that in the earlier international scales, $W(T)$ was defined with reference to the SPRT resistance at 273.15 K, not 273.16 K.

There are two reference functions $W_r(T_{90})$, one for the range 13.8033 K to 273.16 K and another for the range 273.15 K to 1234.93 K. These reference functions will be described in the discussion of the two ranges (secs. 2.3.3 and 2.3.4).

The deviation $\Delta W(T_{90})$ is obtained as a function of T_{90} for various ranges and subranges by calibration at specified fixed points. The form of the deviation function depends upon the temperature range of calibration.

A schematic representation of the ITS-90 in the range of temperature specified for SPRTs is given in figure 3. Shown in figure 3 are the temperatures of the defining fixed points in this region of the scale and the various subranges specified by the scale.

2.3.2 SPRT SPECIFICATIONS

The SPRT sensing element must be made from pure platinum and be strain-free. The finished SPRT must meet one of the following criteria:

$$W(302.9146 \text{ K}) \geq 1.118 \text{ 07, or} \quad (10)$$

$$W(234.3156 \text{ K}) \leq 0.844 \text{ 235.} \quad (11)$$

These criteria are equivalent to a requirement on the slope, namely,

$$[dW(T_{90})/dT_{90}] \geq 3.986 \times 10^{-3} \text{ K}^{-1} \text{ at } 273.16 \text{ K.} \quad (12)$$

An SPRT that is acceptable for use to the freezing point of silver must meet the following additional criterion:

$$W(1234.93 \text{ K}) \geq 4.2844. \quad (13)$$

The temperature range over which an SPRT can be used depends upon the thermometer design, but no single design of SPRT can be used over the whole temperature range with high accuracy. For measurements at temperatures from 13.8033 K (-259.3467 °C) to 429.7485 K (156.5985 °C), or perhaps to as high as 505.078 K (231.928 °C), capsule-type SPRTs that have a nominal resistance of 25.5 Ω at 273.16 K may be used. Long-stem type SPRTs of the same nominal resistance may be used in the range from about 77 K to 933.473 K (660.323 °C). For temperatures above about 660 °C and to as high as 1234.93 K (961.78 °C), long-stem type SPRTs having a nominal resistance of 0.25 Ω (or possibly 2.5 Ω) at 273.16 K should be used. When SPRTs are used at the highest temperatures, leakage currents through the insulation supports of the platinum wire become significant and these result in shunting of the resistor. The effect of this shunting is reduced by using low voltages with low resistance SPRTs.

If the sheath of the long-stem type SPRT is borosilicate glass or stainless steel, the SPRT should not be used above the upper calibration temperature limit of 420 °C. If the sheath is Inconel, the upper temperature limit becomes about

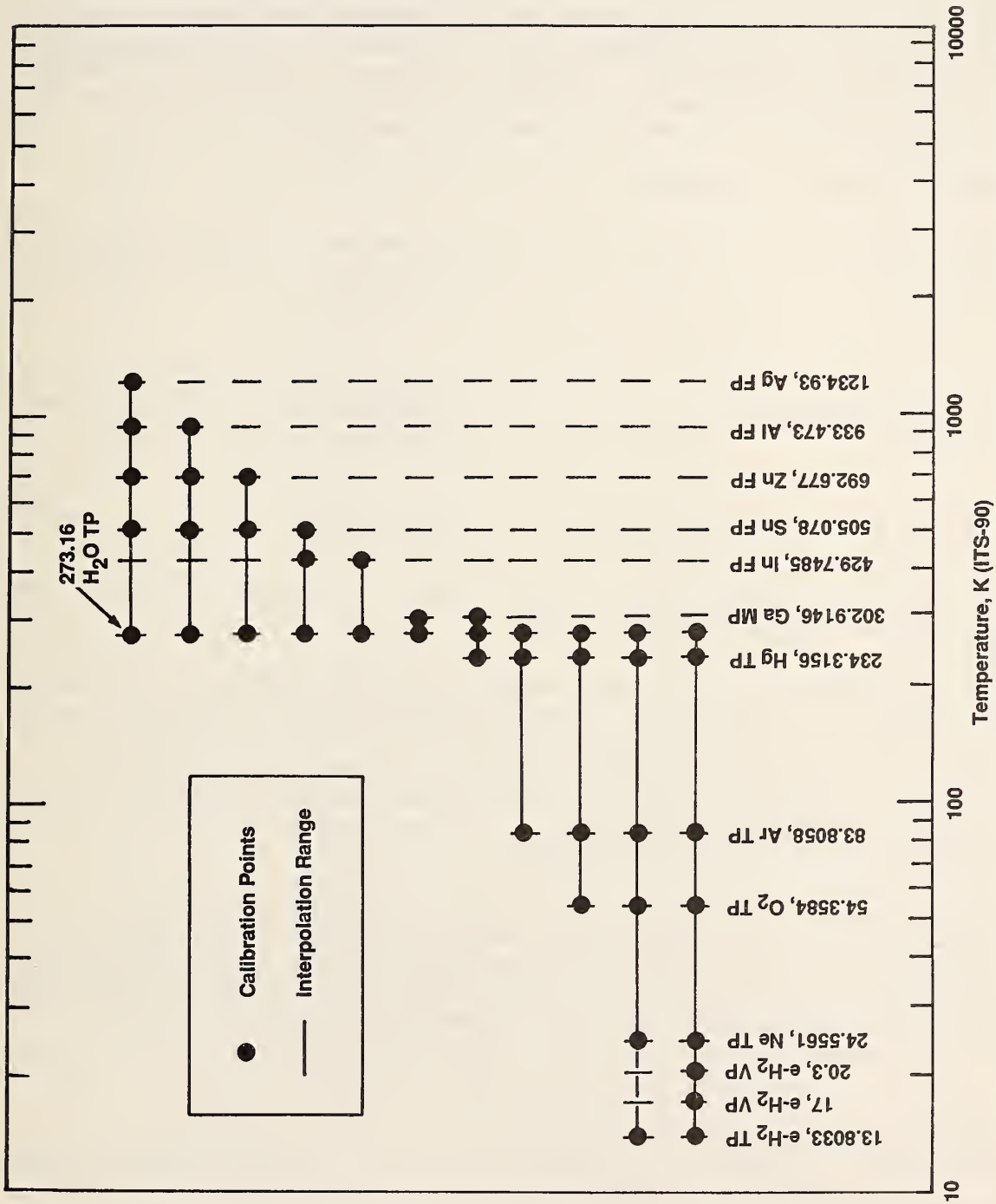

Figure 3. A schematic representation of the ITS-90 in the range specified for the platinum resistance thermometer, showing the various defined subranges and the temperatures of the defining fixed points on the scale required for calibration.

660 °C. If the sheath is fused silica, temperature measurements can be made up to 962 °C.

For measurements up to about 630 °C, mica is just barely adequate as an electrical insulator for the temperature sensing element and leads of SPRTs. Starting at about 500 °C, muscovite mica begins to decompose, evolving water that electrically shunts the thermometer resistor. Phlogopite mica is adequately stable to 630 °C. For measurements up to 962 °C, refractory materials such as fused silica and sapphire are used for electrical insulation.

2.3.3 RANGE 13.8033 K TO 273.16 K

In the range 13.8033 K to 273.16 K, the reference function $W_r(T_{90})$ is given by:

$$\ln[W_r(T_{90})] = A_0 + \sum_{i=1}^{12} A_i \{ [\ln(T_{90}/273.16 \text{ K}) + 1.5]/1.5 \}^i. \quad (14)$$

A specified, approximate inverse [83] of this equation, equivalent to within ± 0.0001 K, is:

$$T_{90}/273.16 \text{ K} = B_0 + \sum_{i=1}^{15} B_i \{ ([W_r(T_{90})]^{1/6} - 0.65)/0.35 \}^i. \quad (15)$$

The values of the constants A_0 and B_0 , and of the coefficients A_i and B_i of equations (14) and (15) are listed in table 5.

If an SPRT is to be used throughout the range from 13.8033 K to 273.16 K, it must be calibrated at the triple points of equilibrium hydrogen (13.8033 K), neon (24.5561 K), oxygen (54.3584 K), argon (83.8058 K), mercury (234.3156 K), and water (273.16 K), and at two additional temperatures close to 17.0 K and 20.3 K. The temperatures of calibration near 17.0 K and 20.3 K may be determined by using either a CVGT as defined in section 2.2 or the specified vapor-pressure-temperature relation of equilibrium hydrogen.

When the CVGT is used, the two temperatures must be within the ranges 16.9 K to 17.1 K and 20.2 K to 20.4 K, respectively. When the equilibrium hydrogen vapor-pressure thermometer is used, the two temperatures must be within the ranges 17.025 K to 17.045 K and 20.26 K to 20.28 K, respectively. The temperatures of the equilibrium hydrogen vapor-pressure thermometer are determined from the values of the hydrogen vapor pressure, p , and the equations:

$$T_{90}/\text{K} - 17.035 = (p/\text{kPa} - 33.3213)/13.32 \quad (16)$$

$$T_{90}/\text{K} - 20.27 = (p/\text{kPa} - 101.292)/30, \quad (17)$$

where 13.32 and 30 are values of $(dp/dT_{90})/(\text{kPa}/\text{K})$ at 17.035 K and 20.27 K, respectively.

Depending upon the temperature range of use, the SPRT may be calibrated from 273.16 K down to 13.8033 K (the triple point of equilibrium hydrogen), down to

Table 5. Values of the coefficients A_i , B_i , C_i and D_i and of the constants A_0 , B_0 , C_0 , and D_0 in the reference functions, eqs (14) and (22), and in the functions approximating them, given by eqs (15) and (23)

Constant or Coefficient	Value	Constant or Coefficient	Value
A_0	-2.135 347 29	B_0	0.183 324 722
A_1	3.183 247 20	B_1	0.240 975 303
A_2	-1.801 435 97	B_2	0.209 108 771
A_3	0.717 272 04	B_3	0.190 439 972
A_4	0.503 440 27	B_4	0.142 648 498
A_5	-0.618 993 95	B_5	0.077 993 465
A_6	-0.053 323 22	B_6	0.012 475 611
A_7	0.280 213 62	B_7	-0.032 267 127
A_8	0.107 152 24	B_8	-0.075 291 522
A_9	-0.293 028 65	B_9	-0.056 470 670
A_{10}	0.044 598 72	B_{10}	0.076 201 285
A_{11}	0.118 686 32	B_{11}	0.123 893 204
A_{12}	-0.052 481 34	B_{12}	-0.029 201 193
		B_{13}	-0.091 173 542
		B_{14}	0.001 317 696
		B_{15}	0.026 025 526
C_0	2.781 572 54	D_0	439.932 854
C_1	1.646 509 16	D_1	472.418 020
C_2	-0.137 143 90	D_2	37.684 494
C_3	-0.006 497 67	D_3	7.472 018
C_4	-0.002 344 44	D_4	2.920 828
C_5	0.005 118 68	D_5	0.005 184
C_6	0.001 879 82	D_6	-0.963 864
C_7	-0.002 044 72	D_7	-0.188 732
C_8	-0.000 461 22	D_8	0.191 203
C_9	0.000 457 24	D_9	0.049 025

24.5561 K (the triple point of neon), down to 54.3584 K (the triple point of oxygen), or down to 83.8058 K (the triple point of argon).

The deviation function for calibration over the range 13.8033 K to 273.16 K is given by the relation:

$$\Delta W_1(T_{90}) = a_1[W(T_{90}) - 1] + b_1[W(T_{90}) - 1]^2 + \sum_{i=1}^5 c_i[\ln W(T_{90})]^{i+n}, \quad (18)$$

with $n = 2$. The coefficients a_1 , b_1 , and the five c_i 's are obtained by calibration at all eight of the above temperatures, including that at the triple point of water. The values of $W_r(T_{90})$ are obtained from the reference function [eq (14)].

The official version of the ITS-90 [83] does not indicate the difference $[W(T_{90}) - W_r(T_{90})]$ by $\Delta W_m(T_{90})$, does not use the subscript m , where in eq (18), $m = 1$, nor does it label the coefficients a and b with subscript m . However, we adopt this subscript notation to identify the subranges. Additionally, this notation is useful when reporting calibration results.

If an SPRT is not to be used over the entire 13.8033 K to 273.16 K range, but its use restricted to one of the subranges, the deviation functions and the calibration points are as follows.

2.3.3.1 SUBRANGE 24.5561 K TO 273.16 K

The deviation function for calibration in the subrange 24.5561 K to 273.16 K is given by the relation:

$$\Delta W_2(T_{90}) = a_2[W(T_{90}) - 1] + b_2[W(T_{90}) - 1]^2 + \sum_{i=1}^3 c_i [\ln W(T_{90})]^{i+n}, \quad (19)$$

with $n = 0$. The coefficients a_2 , b_2 , and the three c_i 's are obtained by calibrating the SPRT at the triple points of equilibrium hydrogen (13.8033 K), neon (24.5561 K), oxygen (54.3584 K), argon (83.8058 K), mercury (234.3156 K) and water (273.16 K). The values of $W_r(T_{90})$ are obtained from the reference function [eq (14)]. Note that for this subrange, temperatures are measured only down to the triple point of neon, although the thermometer must be calibrated at the triple point of equilibrium hydrogen.

2.3.3.2 SUBRANGE 54.3584 K TO 273.16 K

The deviation function for calibration in the subrange 54.3584 K to 273.16 K is given by the relation:

$$\Delta W_3(T_{90}) = a_3[W(T_{90}) - 1] + b_3[W(T_{90}) - 1]^2 + c_1 [\ln W(T_{90})]^{1+n}, \quad (20)$$

with $n = 1$. The coefficients a_3 , b_3 , and c_1 are obtained by calibrating the SPRT at the triple points of oxygen (54.3584 K), argon (83.8058 K), mercury (234.3156 K), and water (273.16 K). The values of $W_r(T_{90})$ are obtained from the reference function [eq (14)].

2.3.3.3 SUBRANGE 83.8058 K TO 273.16 K

The deviation function for calibration in the subrange 83.8058 K to 273.16 K is given by the relation:

$$\Delta W_4(T_{90}) = a_4[W(T_{90}) - 1] + b_4[W(T_{90}) - 1] \ln W(T_{90}). \quad (21)$$

The coefficients a_4 and b_4 are obtained by calibrating the SPRT at the triple

points of argon (83.8058 K), mercury (234.3156 K), and water (273.16 K). The values of $W_r(T_{90})$ are obtained from the reference function [eq (14)].

2.3.4 RANGE 273.15 K (0 °C) TO 1234.93 K (961.78 °C)

In the range 273.15 K to 1234.93 K, the equation for the reference function $W_r(T_{90})$ is given by:

$$W_r(T_{90}) = C_0 + \sum_{i=1}^9 C_i [(T_{90}/K - 754.15)/481]^i. \quad (22)$$

A specified, approximate inverse [83] of this equation, equivalent to within ± 0.00013 K, is:

$$T_{90}/K - 273.15 = D_0 + \sum_{i=1}^9 D_i \{ [W_r(T_{90}) - 2.64]/1.64 \}^i. \quad (23)$$

The values of the constants C_0 and D_0 and of the coefficients C_i and D_i of eqs (22) and (23) are listed in table 5.

If the SPRT is to be used over the entire range 273.15 K to 1234.93 K, it must be calibrated at the triple point of water (273.16 K) and at the freezing points of tin (505.078 K), zinc (692.677 K), aluminum (933.473 K), and silver (1234.93 K).

The deviation function is given by the relation:

$$\begin{aligned} \Delta W_6(T_{90}) = & a_6 [W(T_{90}) - 1] + b_6 [W(T_{90}) - 1]^2 \\ & + c_6 [W(T_{90}) - 1]^3 + d [W(T_{90}) - W(933.473 \text{ K})]^2. \end{aligned} \quad (24)$$

The values of a_6 , b_6 , and c_6 are determined from the measured deviations $\Delta W(T_{90})$ of $W(T_{90})$ from the reference values $W_r(T_{90})$ [obtained from eq (22)] at the freezing points of tin (505.078 K), zinc (692.677 K), and aluminum (933.473 K), ignoring the term involving d . Then, d is determined from these values of a_6 , b_6 , and c_6 and the deviation $\Delta W(T_{90})$ of $W(T_{90})$ from the reference value $W_r(T_{90})$ at the freezing point of silver (1234.93 K). The coefficient d is used only for temperature measurements in the range from the freezing point of aluminum to the freezing point of silver. For temperature measurements below the freezing point of aluminum, $d = 0$.

SPRTs may be calibrated for use throughout the whole range 273.15 K to 1234.93 K or for shorter subranges by calibrations at fixed points between 273.15 K and the upper limit of 933.473 K (freezing point of aluminum, 660.323 °C), of 692.677 K (freezing point of zinc, 419.527 °C), of 505.078 K (freezing point of tin, 231.928 °C), of 429.7485 K (freezing point of indium, 156.5985 °C), or of 302.9146 K (melting point of gallium, 29.7646 °C).

The deviation function $\Delta W_5(T_{90})$ will be discussed later in the text.

If an SPRT is not to be used over the entire 273.15 K to 1234.93 K range, but its use restricted to one of the subranges, the deviation functions and the calibration points are as follows.

2.3.4.1 SUBRANGE 273.15 K (0 °C) TO 933.473 K (660.323 °C, FREEZING POINT OF ALUMINUM)

For an SPRT used throughout the subrange 273.15 K to 933.473 K, the thermometer is calibrated at the triple point of water (273.16 K), and at the freezing points of tin (505.078 K), zinc (692.677 K), and aluminum (933.473 K). The deviation function is given by the relation:

$$\Delta W_7(T_{90}) = a_7[W(T_{90}) - 1] + b_7[W(T_{90}) - 1]^2 + c_7[W(T_{90}) - 1]^3. \quad (25)$$

The coefficients a_7 , b_7 , and c_7 , identical to a_6 , b_6 and c_6 , respectively, are determined from the deviations $\Delta W(T_{90})$ of $W(T_{90})$ from the reference values $W_r(T_{90})$ [eq (22)] at the freezing points of tin (505.078 K), zinc (692.677 K), and aluminum (933.473 K).

2.3.4.2 SUBRANGE 273.15 K (0 °C) TO 692.677 K (419.527 °C, FREEZING POINT OF ZINC)

For an SPRT used throughout the subrange 273.15 K to 692.677 K, the thermometer is calibrated at the triple point of water (273.16 K), and at the freezing points of tin (505.078 K) and zinc (692.677 K). The deviation function is given by the relation:

$$\Delta W_8(T_{90}) = a_8[W(T_{90}) - 1] + b_8[W(T_{90}) - 1]^2. \quad (26)$$

The coefficients a_8 and b_8 are determined from the deviations $\Delta W(T_{90})$ of $W(T_{90})$ from the reference values $W_r(T_{90})$ [eq (22)] at the freezing points of tin (505.078 K) and zinc (692.677 K).

2.3.4.3 SUBRANGE 273.15 K (0 °C) TO 505.078 K (231.928 °C, FREEZING POINT OF TIN)

For an SPRT used throughout the subrange 273.15 K to 505.078 K, the thermometer is calibrated at the triple point of water (273.16 K), and at the freezing points of indium (429.7485 K) and tin (505.078 K). The form of the deviation function is the same as that for the subrange 273.15 K to 692.677 K, i.e.,

$$\Delta W_9(T_{90}) = a_9[W(T_{90}) - 1] + b_9[W(T_{90}) - 1]^2. \quad (27)$$

The coefficients a_9 and b_9 are determined from the deviations $\Delta W(T_{90})$ of $W(T_{90})$ from the reference values $W_r(T_{90})$ [eq (22)] at the freezing points of indium (429.7485 K) and tin (505.078 K).

2.3.4.4 SUBRANGE 273.15 K (0 °C) TO 429.7485 K (156.5985 °C, FREEZING POINT OF INDIUM)

For an SPRT used throughout the subrange 273.15 K to 429.7485 K, the thermometer is calibrated at the triple point of water (273.16 K) and at the freezing point

of indium (429.7485 K). The deviation function is:

$$\Delta W_{10}(T_{90}) = a_{10}[W(T_{90}) - 1]. \quad (28)$$

The coefficient a_{10} is determined from the deviation $\Delta W(T_{90})$ of $W(T_{90})$ from the reference value $W_r(T_{90})$ [eq (22)] at the freezing point of indium (429.7485 K).

2.3.4.5 SUBRANGE 273.15 K (0 °C) TO 302.9146 K (29.7646 °C, MELTING POINT OF GALLIUM)

For an SPRT used throughout the subrange 273.15 K to 302.9146 K, the thermometer is calibrated at the triple point of water (273.16 K) and at the melting point of gallium (302.9146 K). The deviation function is:

$$\Delta W_{11}(T_{90}) = a_{11}[W(T_{90}) - 1]. \quad (29)$$

The coefficient a_{11} is determined from the deviation $\Delta W(T_{90})$ of $W(T_{90})$ from the reference value $W_r(T_{90})$ [eq (22)] at the melting point of gallium (302.9146 K).

2.3.5 SUBRANGE 234.3156 K (-38.8344 °C, TRIPLE POINT OF MERCURY) TO 302.9146 K (29.7646 °C, THE MELTING POINT OF GALLIUM)

For an SPRT used throughout the subrange 234.3156 K to 302.9146 K, the thermometer is calibrated at the triple points of mercury (234.3156 K) and water (273.16 K), and at the melting point of gallium (302.9146 K). The form of the deviation function is the same as that for the subrange 273.15 K to 692.677 K, i.e.,

$$\Delta W_5(T_{90}) = a_5[W(T_{90}) - 1] + b_5[W(T_{90}) - 1]^2. \quad (30)$$

The coefficients a_5 and b_5 are determined from the deviations $\Delta W(T_{90})$ of $W(T_{90})$ from the reference values $W_r(T_{90})$ at the triple point of mercury (234.3156 K) and at the melting point of gallium (302.9146 K). The reference values $W_r(T_{90})$ must be calculated from the appropriate reference function [either eq (14) or eq (22)], both reference functions being required to cover this range.

2.4 ABOVE 1234.93 K (961.78 °C, FREEZING POINT OF SILVER); RADIATION THERMOMETRY BASED ON PLANCK'S LAW OF RADIATION

At temperatures above 1234.93 K, T_{90} is defined by the relation:

$$\frac{L_\lambda(T_{90})}{L_\lambda[T_{90}(X)]} = \frac{\exp[c_2/\lambda T_{90}(X)] - 1}{\exp[c_2/\lambda T_{90}] - 1}, \quad (31)$$

in which $L_\lambda(T_{90})$ and $L_\lambda[T_{90}(X)]$ are the spectral concentrations of the radiance of a blackbody at wavelength λ (in vacuum) at T_{90} and at $T_{90}(X)$, respectively. $T_{90}(X)$ refers to either the silver freezing point [$T_{90}(\text{Ag}) = 1234.93$ K], the gold freezing point [$T_{90}(\text{Au}) = 1337.33$ K] or the copper freezing point [$T_{90}(\text{Cu}) = 1357.77$ K]. The second radiation constant, c_2 ($= hc/k$), of Planck's radiation formula has the value $c_2 = 0.014388$ m·K. Although the freezing-point

temperature of silver is the junction point of platinum resistance thermometry and radiation thermometry, it is believed that the T_{90} values of the freezing points of silver, gold and copper are sufficiently self-consistent that the use of any one of them as the reference temperature $T_{90}(X)$ will not result in any significant difference in the measured values of T_{90} from what would be obtained if only the silver freezing point were used.

3. REALIZATION OF THE ITS-90

3.1 VAPOR PRESSURE THERMOMETRY AND GAS THERMOMETRY

3.1.1 REALIZATION OF THE ITS-90 BELOW 273.16 K

The calibration of thermometers below the triple point of argon on the ITS-90, as defined, is relatively complex. It is expected that capsule-type SPRTs, rhodium-iron resistance thermometers (RIRTs), and other stable encapsulated resistance thermometers will be calibrated in terms of the defined ITS-90 and then used as reference thermometers to maintain the ITS-90 below about 84 K and used to calibrate other resistance thermometers by the comparison method. The reference thermometers will be calibrated periodically in terms of the defined ITS-90.

By use of the term "realization of the ITS-90," reference is made to obtaining the equilibrium states as defined by the scale, to having thermometers in thermal equilibrium with those equilibrium states, and to making accurate measurements and interpretations of the requisite properties of those thermometers in terms of the ITS-90.

Considerable effort has been expended to develop and realize the EPT-76, a scale which covered the range 0.5 K to 30 K. This scale has been widely disseminated among low temperature scientists. At NIST, the EPT-76 has been maintained on reference-standard RIRTs for use in calibrating customer thermometers. Upon introduction of the ITS-90, NIST converted the EPT-76 on the reference-standard RIRTs to the ITS-90 using the specified differences [83] between T_{90} and T_{76} . This converted scale is being used to calibrate other thermometers until such time that NIST realizes the ITS-90 in this temperature region directly as defined. It is recommended that those laboratories that have thermometers with calibrations on the EPT-76 adjust their T_{76} values to conform to T_{90} values. When NIST realizes the ITS-90 as defined in this range, the difference between the converted scale on the reference-standard RIRTs (and where appropriate, on capsule SPRTs) and the realized scale will be determined.

3.1.2 VAPOR PRESSURE THERMOMETRY AND THE CVGT RANGE

For most measurements below about 100 K, better precision can be obtained with capsule-type SPRTs than with the long-stem type. In the calibration of SPRTs, however, long-stem type SPRTs (immersion-type SPRTs) can be calibrated easily by a direct immersion process down to the triple point of argon (83.8058 K) by moving the SPRTs from one fixed-point device to another. Unless capsule-type SPRTs and other capsule-type thermometers are installed inside long stem-like holders, however, they will require re-installation and re-wiring whenever different fixed-point apparatuses are used. (In this document, the phrase

"capsule-type thermometers" means encapsulated resistance thermometers of small overall dimensions.) It is desirable, therefore, to be able to calibrate capsule-type SPRTs and other capsule-type thermometers at the argon triple point and below (or, if possible, even at the triple point of water and below since calibrations of SPRTs require measurements at the triple point of water) in an integrated "multi-task" (multi-fixed-point) apparatus. Such a multi-task apparatus requires, in addition to wells for capsule thermometers (in thermal equilibrium in a "single cryostat block"), means for calibration using ^3He , ^4He , and e- H_2 vapor pressure thermometry, ^3He and ^4He CVGTs, and triple points of e- H_2 , Ne, O_2 , Ar, Hg, and H_2O . A total of 11 chambers is required if all of the overlapping definitions of the ITS-90 are to be evaluated and if a "continuous calibration," without re-installation and re-wiring of the SPRTs, is desired from 0.65 K to 273.16 K. In addition, unless high pressure sealed cells of the reference gases are used, tubes to each of the chambers, except those for Hg and H_2O , are required.

Since ^3He and ^4He vapor-pressure and CVGT ranges overlap to a large extent, chambers for ^4He vapor-pressure measurements and for ^4He CVGT measurements could be eliminated and the ITS-90 could still be realized. Also, chambers for e- H_2 vapor-pressure and the e- H_2 triple-point realizations could be combined. The number of chambers could be reduced further if the cryostat block could be allowed to warm to ambient temperature or higher for exchanging certain of the fixed-point substances, or if it were permissible to perform the calibrations of the capsule thermometers at the triple points of argon, mercury, and water in other apparatuses, using a long-stem type holder. This procedure, however, would require a longer time for calibration.

The number of chambers can also be reduced if suitable, highly stable capsule thermometers are available for correlating the scales; for this purpose, the capsule SPRTs would be calibrated in another, simpler, fixed-point apparatus. It is expected that such a set of reference-standard resistance thermometers would be calibrated, and that routine calibrations of customer thermometers on the ITS-90 would be by comparison with these reference thermometers. The reference thermometers would be checked occasionally against the defined ITS-90. It is hoped that resistance thermometer devices will be more reproducible than the ability to realize the defined ITS-90. Depending upon the design of the cryostat, the defined ITS-90 may lack the desired reproducibility when realized in a multi-task apparatus of high complexity. In order to achieve the best realization of the ITS-90, it may be more practical to limit the number of defining fixed points in a single cryostat block.

The greatest problem in realization of the fixed points and in calibrations of capsule thermometers is ensuring that the multi-task or a "single-task" cryostat block is isothermal. Depending upon the design, a thermal gradient can persist. The presence of ^3He , ^4He , e- H_2 , Ne, O_2 , and/or Ar gases in their respective chambers are expected to be beneficial in making the apparatus isothermal, but, the gases may be a source of thermal oscillation. (In designing an apparatus for low temperature gases, provisions should be made to avoid thermal oscillations in the gas.) The vapor pressures of Ne and Ar are high at their respective triple-point temperatures so that thermal equilibrium should be easily attained at their triple points.

For a practical cryostat block, the ^3He and ^4He CVGTs must connect thermally the ^3He and ^4He vapor-pressure scales and the fixed points of e- H_2 and Ne. Such a cryostat block will require six chambers (separate ^3He and ^4He vapor-pressure chambers, separate ^3He and ^4He CVGT chambers, e- H_2 vapor-pressure and e- H_2 triple-point chamber, and a Ne chamber) to realize the ITS-90 in the most satisfactory manner at and below the Ne triple point. This arrangement will permit a direct comparison of the different parts of the scale and/or calibration of thermometers. Since the combination of ^4He vapor-pressure thermometry and ^4He constant volume gas thermometry are redundant with ^3He vapor-pressure thermometry and ^3He constant volume gas thermometry, the ^4He systems are not required. Hence, the number of chambers required could be reduced to four and the ITS-90 could still be realized. It should be noted, however, that, depending upon the CVGT filling pressure, the dp/dT of a ^3He CVGT may be less sensitive than ^4He vapor-pressure thermometry. Since SPRTs can be calibrated only down to the argon triple-point temperature using the long-stem SPRT apparatus, it would be most practical and useful to include an oxygen triple-point chamber in the low-temperature system, thereby increasing the number of chambers to five. Also, since it is highly desirable to overlap calibrations obtained in a long-stem type SPRT apparatus with those obtained in a low-temperature apparatus, an argon triple-point chamber should be included. This increases the number of chambers for the low-temperature apparatus to six.

Although it is desirable to have as few tubes as possible going to the cryostat block in order to minimize temperature gradients in the block, one must build into the system enough redundant components to be able to check the system for proper and accurate operation. For example, although the CVGT is calibrated at only the triple-point temperatures of neon and hydrogen and at one point in the ^3He or ^4He vapor pressure range between 3.0 K and 5.0 K, the system should have the capability for the measurement of hydrogen vapor pressures at about 17 K and 20.3 K so that temperatures measured by means of vapor pressures and by the CVGT may be compared. Of course, if the system is operating properly, the temperatures measured by the two techniques should agree. Similarly, there should be the capability to measure the vapor pressures of both ^3He and ^4He so that temperatures measured with the CVGT in the range from 3 K to 5 K and by means of ^3He and ^4He vapor pressures may be compared for agreement. Also, it is desirable to design the CVGT for absolute gas thermometry measurements; the CVGT can check the consistency of the ITS-90 from about 3 K to 90 K.

3.1.3 REALIZATION OF THE VAPOR PRESSURE AND CVGT SCALES AT TEMPERATURES BELOW THE NEON TRIPLE POINT

Since measurement of pressure is common to both vapor pressure and CVGT measurements, it will be discussed later in this section (see sec. 3.1.3.5).

In vapor pressure measurements, it is important that cold spots be absent along the gas-pressure transmitting tube. If cold spots are present, the observed vapor pressure will reflect the temperature of the condensation at the cold spot instead of that of the bulk bath. A separate vacuum jacket around the tube will maintain a continuous heat flux to the sample bulb or bath and should free the tube of any condensation [24]. The vacuum jacket should also reduce the occurrence of thermal oscillation in the gas-pressure sensing tube. If thermal oscillations do occur, they may be suppressed by either one or a combination of

the following: increasing the volume of the external gas-pressure space at the ambient temperature, or by inserting a wad of wool or glass fiber or a piece of yarn in the gas-pressure sensing tube. The thermal oscillations may be suppressed also by "tuning" a variable volume device [36]. Thermocouples should be placed along the gas-pressure sensing tube in order to determine temperatures along that tube, the distribution of those temperatures being required to determine the aerostatic head correction.

The vapor pressure may be determined over the bath of bulk liquid ^3He , ^4He , or $e\text{-H}_2$ with which the thermometer to be calibrated is in thermal equilibrium. The measurement can be made also by using a separate, small sample bulb with which the thermometer is in good thermal contact. The latter method is preferred with the rather expensive ^3He and with $e\text{-H}_2$, which requires a catalyst for the equilibrium ortho-para conversion of the sample [2,58,91].

3.1.3.1 ^3He Vapor-Pressure Measurements

Because of the relatively high cost of the sample, vapor-pressure measurements are made with ^3He contained in a small volume of about 5 cm^3 . Likewise, the gas-pressure volume to the manometer should be kept relatively small, but large enough to avoid large thermomolecular pressure effects and thermal oscillations. Thermomolecular-pressure-effect corrections depend on the sensing tube diameter, surface condition of the tube, temperature difference, and pressure [49,71,102]. As mentioned above, thermal oscillations can be reduced by varying the gas-pressure volume at the ambient temperature or by introducing a wad of fiber or yarn (cotton, wool, or glass) in the gas-pressure tube.

In the past, ^3He contained significant amounts of ^4He and the observed vapor pressures of ^3He required corrections for its presence. In recent years, however, ^3He samples of 99.9995% purity have become available, eliminating the requirement for such corrections. At 0.65 K, the vapor pressure and the temperature derivative of the vapor pressure are 115.9 Pa and 1.08 Pa/mK, respectively. At the upper limit of 3.2 K, the vapor pressure and the temperature derivative of the vapor pressure are 101,662.1 Pa and 106.83 Pa/mK, respectively. The required pressure resolution that corresponds to 0.1 mK of vapor-pressure measurements varies from 0.108 Pa at 0.65 K to 10.7 Pa at 3.2 K.

Since the amount of ^3He in the cryostat is small, and since the amount of ^4He used in cooling is relatively large, every effort should be made to avoid contamination of the sample of ^3He by the ^4He through diffusion, particularly through any glass parts of the apparatus.

The sample bulb should contain enough ^3He that the liquid surface temperature and the cryostat block temperature can be correlated with the observed vapor pressure. The temperature of the cryostat block must be checked for consistency with the observed dp/dT of the vapor pressure at the temperature of measurement.

Aerostatic-head corrections depend upon the density of the gas in the pressure-transmitting gas tube. Thermocouples must be distributed along the tube in order to measure the temperatures required for calculation of these corrections.

3.1.3.2 ⁴He Vapor-Pressure Measurements

Since liquid ⁴He can be obtained easily, the vapor pressure can be determined above a bath of the liquid in which an apparatus containing the thermometer is immersed. Or, a technique using a small bulb of ⁴He sample, with the thermometer in good thermal contact, can be employed. The lower end of the gas-pressure tube should have a small orifice in order to reduce superfluid ⁴He film flow at temperatures below 2.1768 K [61,91]. The ⁴He sample bulb must be in thermal equilibrium with the cryostat block. The cryostat block temperature should be checked for consistency with the observed dp/dT of the vapor pressure at the temperature of measurement.

At the lower temperature limit of 1.25 K, the vapor pressure of ⁴He is 114.7 Pa and the temperature derivative of the vapor pressure is 0.76 Pa/mK. At the upper limit of 5 K, the vapor pressure and the temperature derivative of the vapor pressure of ⁴He are 194629.7 Pa and 146.53 Pa/mK, respectively. The required pressure resolutions of the vapor pressure that corresponds to 0.1 mK are 0.076 Pa at 1.25 K and 14.7 Pa at 5.0 K [37,38].

3.1.3.3 e-H₂ Vapor Pressure Measurements

The equilibrium composition of the two molecular states of hydrogen (ortho and para) is temperature dependent. The room temperature composition, about 75% ortho and 25% para, is referred to as normal hydrogen (n-H₂). On liquefaction, the composition slowly changes toward the equilibrium composition corresponding to its temperature. In the process, the heat of transition is released, resulting in the evaporation of some hydrogen. A catalyst, such as activated ferric hydroxide, hastens the equilibration. The catalyst must be placed in the sample chamber in order to ensure that the hydrogen has the appropriate equilibrium composition. Most of the conversion must be made before collecting the liquid in the sample chamber since the heat of conversion (1064 J/mol) from the ortho to the para molecular state is larger than the heat of vaporization (900 J/mol) of normal hydrogen. The normal boiling point of e-H₂ (equilibrium composition: 0.21% ortho and 99.79% para) is about 0.12 K lower than that of n-H₂. The temperatures near 17.035 K and 20.27 K are determined from vapor-pressure measurements near 33,321.3 Pa and 101,292 Pa, respectively [2,31,58].

3.1.3.4 Constant Volume Gas Thermometry

Some of the following precautions and corrections that are applicable to absolute constant-volume gas thermometry should be included in the calibration of the CVGT at the three specified temperatures of calibration:

1. The volume of the gas bulb should be sufficiently large relative to the gas-pressure-line volume to minimize the error in correcting for the "dead space." On the other hand, the diameter of the gas-pressure line should not be so small as to cause large thermomolecular pressure corrections.
2. The temperature coefficient of volume expansion and the pressure expansion of the gas bulb should be known accurately. (It is desirable to check the calibration by using the CVGT in the absolute mode.)

Table 6. The effect of pressure on the temperatures of the defining fixed points. The reference pressure for the equilibrium states of freezing and melting points is one standard atmosphere (101,325 Pa). Triple points have the vapor pressure of the material when the solid, liquid and vapor phases are present in equilibrium

Material	T_{90}	Pressure Effect of Fixed Point	
		K Pa ⁻¹ x10 ^{8*}	mK/(meter of liquid)
e-H ₂ TP	13.8033	34	0.25
Ne TP	24.5561	16	1.9
O ₂ TP	54.3584	12	1.5
Ar TP	83.8058	25	3.3
Hg TP	234.3156	5.4	7.1
H ₂ O TP	273.16	-7.5	-0.73
Ga MP	302.9146	-2.0	-1.2
In FP	429.7485	4.9	3.3
Sn FP	505.078	3.3	2.2
Zn FP	692.677	4.3	2.7
Al FP	933.473	7.0	1.6
Ag FP	1234.93	6.0	5.4
Au FP	1337.33	6.1	10.
Cu FP	1357.77	3.3	2.6

* Equivalent to millikelvins per standard atmosphere.

3. In order to be able to calculate the aerostatic head correction, the temperature distribution along the connecting gas-pressure transmitting tube (capillary) must be known. That temperature distribution may be determined by placing thermocouples along the tube.

4. The gas-bulb filling pressure should be sufficiently high to give an adequate dp/dT for measurement, but not so high as to require large corrections for non-ideality of the gas.

5. Higher pressures reduce the thermomolecular pressure gradients in the connecting gas-pressure tube.

6. The effect of adsorption can be reduced by designing the gas bulb so that the volume is large relative to the surface and by polishing the inside surface of the bulb.

For optimizing the CVGT design, the ideal gas law may be applied. Differentiating the ideal gas relation,

$$pV = nRT, \quad (32)$$

yields

$$dp/dT = Rn/V, \quad (33)$$

where p is the pressure of n moles of gas contained in a volume of V m³.

Equation (33) shows that the dp/dT sensitivity of the CVGT is directly related to the gas density n/V . Expressing the gas constant R as 8.31441 Nm/mol·K or 8.31441 Nm³/(m²·mol·K), the sensitivity dp/dT can be expressed in the units Pa/K. Thus,

$$dp/dT = 8.31441(n/V) \text{ Pa/K}, \quad (34)$$

where n/V is given in mol/m³. If a gas bulb of 1000 cm³ is filled to four atmospheres at 273.16 K, n/V would be approximately 178 mol/m³, and dp/dT becomes 1484 Pa/K. Since the resolution of many high quality mercury-manometer systems is about 0.03 Pa to 0.2 Pa, the temperature resolution is about 0.03 mK to 0.1 mK. It is to be noted that since

$$p/T = Rn/V, \quad (35)$$

the sensitivity dp/dT is "constant," independent of the gas bulb volume, as long as the gas density at the filling temperature is constant. Hence, the gas-bulb volume and the gas filling pressure should be chosen so that errors from the effect of dead space, gas non-ideality effects, and other effects are negligibly small. See references [6,13,49,60].

3.1.3.5 Pressure Measurements

Efforts have been made to minimize the requirement of highly-precise and accurate pressure measurements in the realization of the defining fixed points of the ITS-90. The fixed points involving freezing and melting require knowledge of the pressure only within the significance of the relatively small pressure effect (cf. table 6). Accurate pressure measurements are required, however, to realize the vapor-pressure-temperature scales of ³He and ⁴He in the range 0.65 K to 5.0 K, and to realize the vapor-pressure-temperature scale of e-H₂ close to 17.035 K and 20.27 K. To realize the CVGT scale using ³He or ⁴He gas in the range 3.0 K to the triple point of neon (24.5561 K), only accurate pressure-ratio measurements are required.

3.1.3.5.1 Mercury Manometry

Mercury manometry requires precise determination of the difference in height of the two mercury surfaces in a U-tube manometer. Traditionally, cathetometers have been used with a smallest imprecision of about 2 Pa. In recent years, the levels have been sensed, in conjunction with length standards, by capacitive and interferometric methods. The resolution of such mercury manometry systems is about 0.05 Pa [19,50,52,81]. (Note: the NIST manometry resolution has been reported [50] to be about 0.0013 Pa.) For accurate pressure measurements, it is necessary to know the density of mercury (which is pressure and temperature

dependent), the capillary depression at the mercury meniscus, the vapor pressure of mercury, the aerostatic head difference of the pressure transmitting gas or gases, and the local acceleration due to gravity. At one standard atmosphere, uncertainties of absolute pressure measurements of about 3 ppm and pressure ratios of about 1 ppm have been reported. See references [19,50,52,81].

3.1.3.5.2 Oil Manometry

The techniques and the requirements of oil manometry are similar to those of mercury manometry.

3.1.3.5.3 Piston Gauges (Pressure Balances)

The pressure balanced by a dead-weight piston gauge is obtained from the mass of the piston and the applied weights, and the effective area of the freely rotating piston inside a closely-fitting cylinder. For determination of the absolute pressure, the gauge must be enclosed and evacuated by a high capacity pumping system to minimize the back pressure from the gas leaking between the piston and the cylinder [13,60,81,96]. The local acceleration due to gravity must be known accurately. Corrections must be applied for the effect of the streaming gas and for any back pressure. It is advisable to check the readings of the piston gauge against a primary mercury manometer. Also, the variation of the effective area with pressure must be determined with a mercury manometer. The aerostatic head of the manometry system will change as gas leaks between the piston and the cylinder causing the piston to sink deeper into the cylinder. The position of the piston may be maintained by automatically pumping more gas into the system. A resolution of 1 ppm [13] and an uncertainty of about 15 ppm have been reported in the pressure range 2 kPa to 200 kPa [63,81].

3.1.3.5.4 Diaphragm Pressure Detector

The diaphragm pressure detector consists of a thin metal disk clamped under tension between two flat electrodes which form two capacitors, with the disk common to both capacitors. Any pressure differential across the metal disk causes the disk to deflect, increasing the capacitance on one side while decreasing the capacitance on the other side. This change is detected by capacitance bridge techniques. Instruments for absolute pressure measurements are available; however, they require periodic recalibrations to achieve uncertainties of 1 to 5 parts in 10^4 of the readings.

The diaphragm pressure detector is used in high precision manometry as pressure balance detectors, i.e., with the pressures equal on both sides of the diaphragm. The diaphragm pressure balance detector separates the gas of the apparatus (vapor pressure apparatus or GVGT) from the counter-balancing gas of which the pressure is determined.

The resolution of diaphragm gauges has been reported [13] to be about 0.002 Pa. Instability due to different pressures, hysteresis, temperature effects, and other causes may decrease the resolution to 0.02 Pa in actual pressure measurements [13].

3.1.3.5.5 Thermomolecular Pressure Difference

Thermomolecular pressure differences occur at low gas pressures in tubes with temperature gradients when the tube diameter is not much larger than the mean free path of the gas. The pressure difference depends upon the gas, the temperature of the gas, the diameter of the tube, the tube material, and the surface condition of the tube. The best procedure is either to use a sufficiently large tube to minimize the thermomolecular pressure difference or to experimentally determine the difference by comparing the pressures between the small diameter tube being used in the cryostat and a large diameter tube [49,71,102].

3.2 REALIZATION OF THE FIXED POINTS OF THE ITS-90

3.2.1 EFFECT OF IMPURITIES

Except for the vapor-pressure-temperature points of helium and equilibrium hydrogen, the fixed points of the ITS-90 are freezing points, melting points, or triple points. The vapor-pressure measurements with ^3He , ^4He , and e- H_2 must be performed with sufficiently pure samples to minimize the effects of impurities. The principal components of air impurity would be frozen. Neon in hydrogen, however, causes positive deviations from ideal behavior [93,97]. In the vapor pressure measurements of ^4He , it is very likely that the ^4He will be pure but ^3He may contain some ^4He . For such a circumstance, Roberts, Sherman and Sydoriak described a procedure for correcting for the presence of ^4He in ^3He [90].

The temperatures of freezing points (liquid-solid or liquid-solid-vapor equilibrium points) of substances are usually lowered by the presence of an impurity. This sometimes, however, is not the case when that impurity is soluble in both the liquid and the solid phases of the major component. If a given impurity is known to be present or is suspected, one must consult the literature on the heterogeneous phase data of metal and non-metal systems to estimate the possible effect of that impurity on the freezing point [39,51,88]. (Note: often in the analysis of the effect of impurities on freezing points, the impurity is assumed to be nonvolatile.)

Assuming that the ideal solution law holds and that the impurities remain in liquid solution, with no concentration gradients, then as the major component slowly freezes, the depression in the freezing point, relative to the freezing point of the 100% pure material, is directly proportional to the overall impurity concentration divided by the "first cryoscopic constant." This is expressed as:

$$T(\text{pure}) - T(\text{obs}) = x_2/A. \quad (36)$$

In eq (36), $T(\text{obs})$ is the observed freezing point of the particular sample being investigated, $T(\text{pure})$ is the freezing point of the 100% pure material, x_2 is the mole fraction impurity concentration, and A is the first cryoscopic constant. A is given by the relation:

$$A = L/R[T(\text{pure})]^2, \quad (37)$$

Table 7. Latent heats of fusion and first cryoscopic constants of defining fixed-point materials

Substance	Fixed Point Temperature	Latent Heat of Fusion	First Cryoscopic Constant
	T/K	kJ/mole	K ⁻¹
e-H ₂	13.8033	0.117	0.0739
Ne	24.5561	0.335	0.0668
O ₂	54.3584	0.444	0.0181
Ar	83.8058	1.188	0.0203
Hg	234.3156	2.292	0.00502
H ₂ O	273.16	6.008	0.00968
Ga	302.9146	5.585	0.00732
In	429.7485	3.264	0.00213
Sn	505.078	6.987	0.00329
Zn	692.677	7.385	0.00185
Al	933.473	10.79	0.00149
Ag	1234.93	11.30	0.000891
Au	1337.33	12.364	0.000831
Cu	1357.77	13.14	0.000857

where L is the molar heat of fusion and R is the molar gas constant. (Note: eq (36) is an approximation. A more complete expression includes secondary cryoscopic constants. The term "first cryoscopic constant" is used here for distinction. Also, in some cases, the term "cryoscopic constant" refers to the reciprocal of eq (37) and in other cases, to the effect of impurities per liter or kilogram of solvent.) The first cryoscopic constants of metals are relatively smaller than those of molecular substances and of the "cryogenic" gases (³He, ⁴He, e-H₂, Ne, O₂, and Ar). Referring to eq (36), zinc, which has a first cryoscopic constant of 0.0018/K, requires an overall impurity concentration of approximately 2 parts in 10⁷ for the temperature of the half-frozen sample to be depressed by 0.0001 K, relative to the liquidus point. On the other hand, argon, with a first cryoscopic constant of 0.0203/K, requires an impurity concentration close to 2 part in 10⁶ for the same temperature depression. Table 7 lists the heats of fusion and the first cryoscopic constants of substances specified for the defining fixed points. It is the usual practice at NIST to calibrate SPRTs during the first 50% of the freeze.

3.2.2 TRIPLE POINTS OF e-H₂, Ne, O₂, AND Ar

3.2.2.1 GENERAL CONSIDERATION OF APPARATUS DESIGN

The cryogenic fixed points (triple-points of pure gases: equilibrium hydrogen, natural neon, oxygen, and argon) are best realized in a calorimetric type apparatus designed for calibrating capsule-type thermometers (SPRTs, RIRTs, germanium resistance thermometers (GRTs), and others) [1,2,17,18,20,21,41,47,58,59,78,79,80]. During calibration of the thermometers,

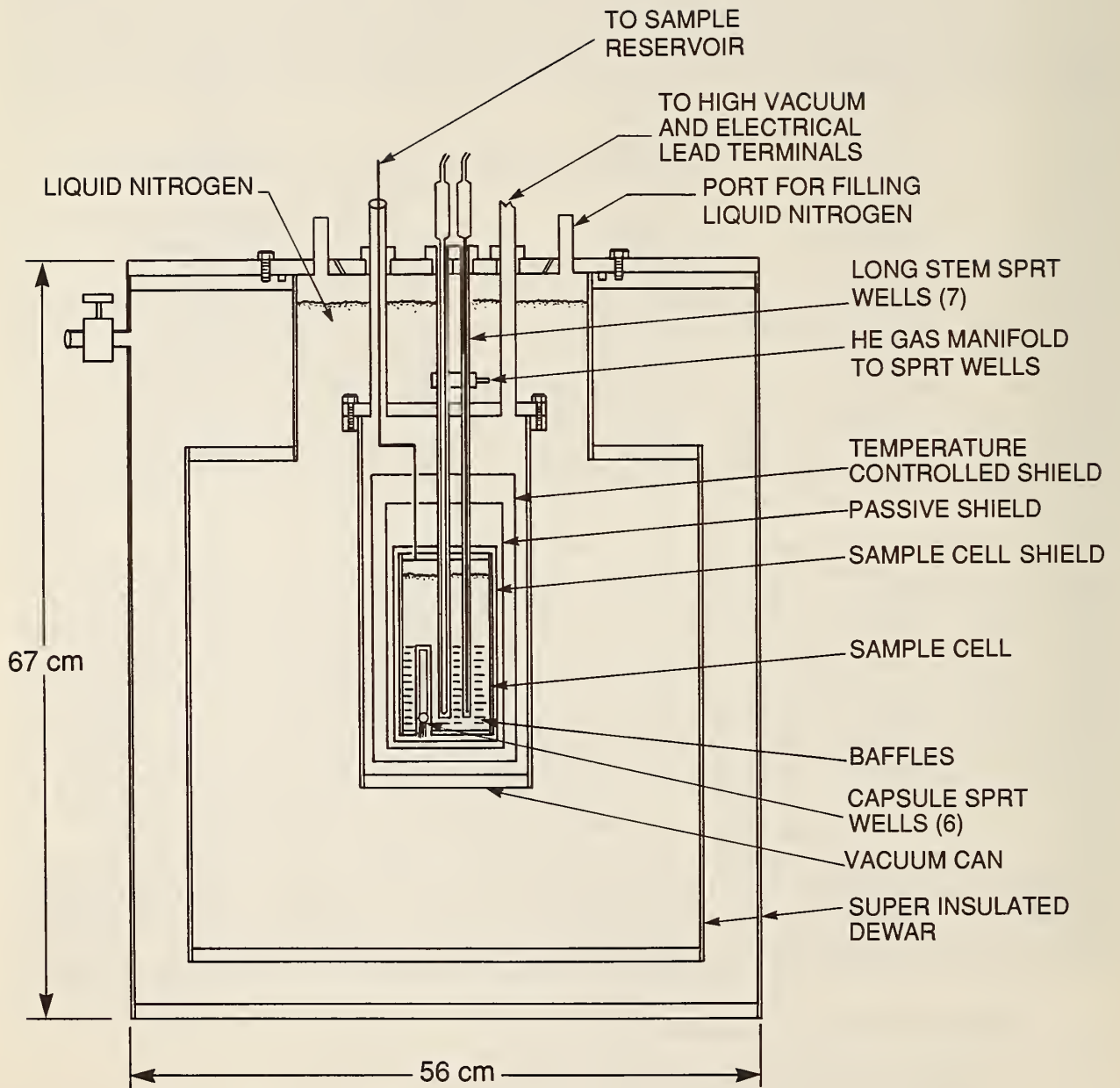

Figure 4. A schematic drawing of the NIST argon triple-point apparatus for calibrating seven long-stem SPRTs and six capsule SPRTs. Six long-stem SPRT wells surround a central SPRT well, which is large enough to accommodate a holder for calibrating a capsule SPRT. At the bottom of the sample cell, six capsule SPRT wells are circularly arranged between the long-stem SPRT wells.

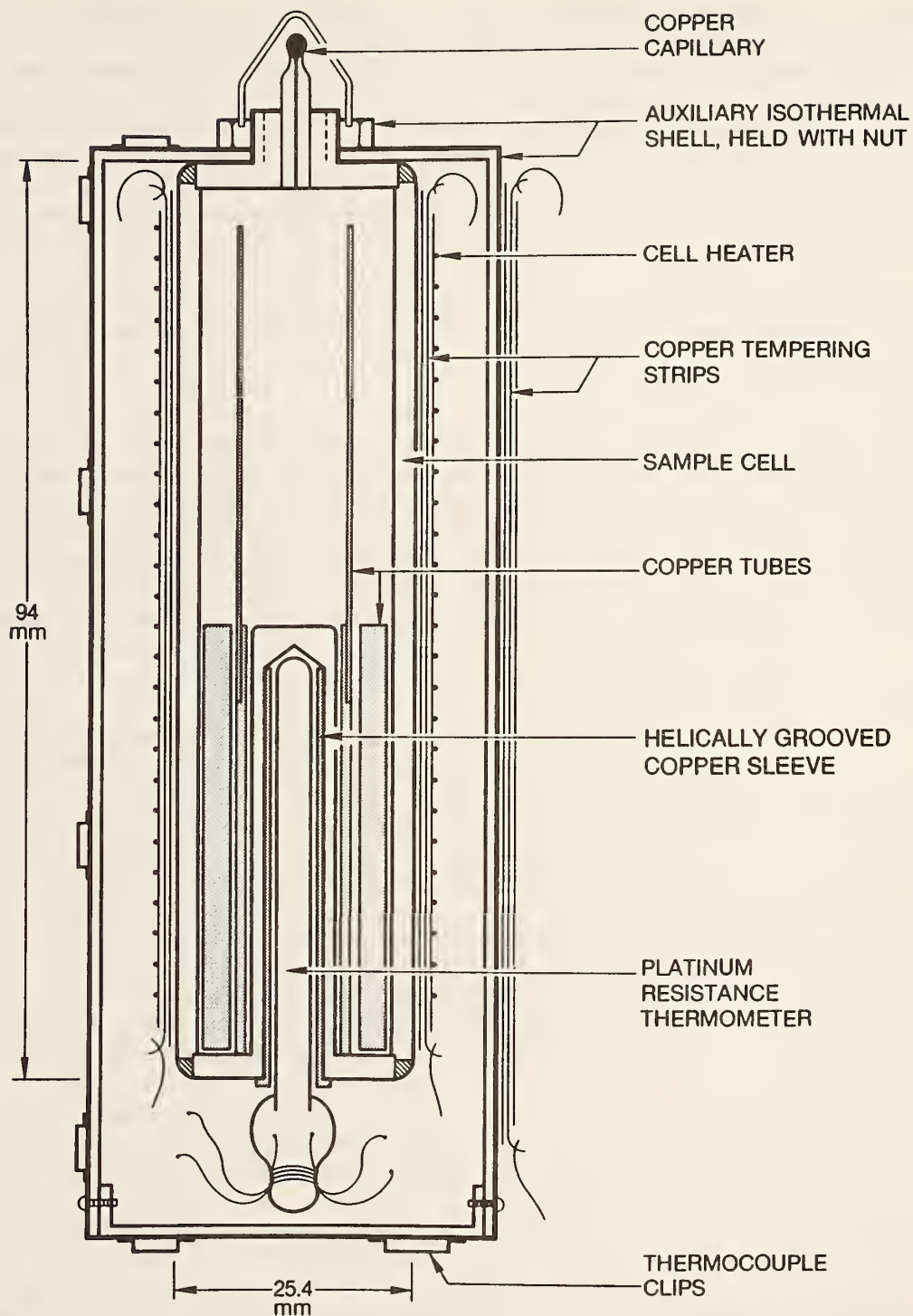

Figure 5. A sealed cell suitable for containing cryogenic gases at high pressures. This cell of 20 cm^3 volume was filled to 100 atmospheres with pure oxygen and used to realize the triple point of oxygen. Another cell of the same outer dimensions, but of 16 cm^3 volume and with wells for three capsule SPRTs, was filled to 163 atmospheres with oxygen and also used to realize the triple point of oxygen [47].

the calorimeter system thermally isolates the vessel containing the pure gas sample and the thermometers. The capsule thermometers should be installed in close-fitting wells of the sample vessel, using stopcock grease to enhance the thermal contact. The wells should be vented for easy installation and subsequent removal of the thermometers since such thermometers are sensitive to shock. The wells can be vented by designing the well tubes to extend completely through the sample cell or by machining a small groove along the length of the well wall. The number of wells in the vessel is limited only by the practical size of the vessel and of the calorimeter system. On the other hand, for large vessels, larger temperature gradients should be expected. The leads to the thermometers should be tempered on the sample vessel. (Note: the term "temper" refers to a process whereby sections of the leads or of the protective sheaths of long-stem SPRTs are placed in "steady-state thermal equilibrium" with selected parts of the apparatus.)

Since the triple point of argon is about 6 K above the normal boiling point (NBP) of nitrogen and since liquid nitrogen is readily available in large quantities, long-stem type SPRTs can be calibrated at the argon triple point in an apparatus cooled by liquid nitrogen. The apparatus should be designed to cool the upper part of the protective sheath of the long-stem SPRTs to liquid nitrogen temperatures, and then to heat the intermediate section of the sheath above the sensing element to the argon triple point so that the sensing coil will be in thermal equilibrium with the argon at its triple point [42]. See figure 4 for a schematic of such an apparatus presently in use at the NIST.

Sample vessels for the cryogenic fixed points could be ruggedly constructed for high pressures and sealed with a suitable amount of the pure gas [41,79]. These "sealed-sample vessels" can be easily installed and removed from the calorimeter for replacement of thermometers and also to be transported to other laboratories for comparison (see fig. 5). The amount of gas that can be sealed in such vessels, however, is rather limited and, hence, the calorimetric system must be operated with sufficient adiabatic control that the small amount of heat of fusion of the sample is adequate to realize the triple point and then calibrate the thermometers. Also, since the amount of sample gas is small, extra care must be taken to clean the vessel thoroughly before filling. The recommended procedure is to bake the vessel at high vacuum and then purge many times with the sample gas before finally filling and sealing the cell [41,47,79].

The vessel for a cryogenic fixed point can be installed in the calorimeter and connected by a small diameter tube to a source of pure gas [1,2,31,32,44,58,59]. In this design, enough condensed liquid could be used to nearly fill the vessel and, thus, to provide an abundant supply of heat of fusion for calibration of thermometers. The tube from the vessel must be connected to an "external expansion volume" of appropriate size so that when the system is at ambient temperature the pressure is not excessive. The vessel could also be connected to an external rugged container into which all or nearly all of the sample can be transferred by cooling, and then contained by a high-pressure valve. Since under these conditions the sample vessel would not be subjected to high pressures, it can be constructed of thin copper parts. With appropriate gas handling and cleaning provisions, the same vessel could be used with all of the reference gases, stored in separate external rugged containers, and the thermometers calibrated at the fixed points of the gases without the necessity

of having to remove the thermometers from the vessel between fixed-point determinations. On the other hand, the "sample vessel" can have separate chambers for each of the gases. In the latter design, separate tubes for the gases must enter the calorimeter system. Although each of the chambers of a "multi-chamber sample vessel" would be relatively small, the amount of sample that could be condensed inside each chamber would still be more than that which is normally used with the high pressure "sealed-sample vessel." Similar to the procedure used in filling sealed-sample vessels, a thorough baking, pumping, and purging procedure before filling should be followed with permanently installed vessels.

3.2.2.2 REALIZATIONS OF THE TRIPLE POINTS AND THEIR APPLICATION TO CALIBRATION

The procedure for realizing a triple point of the cryogenic gases is to first completely freeze the sample. If the triple point is being realized for the first time with the apparatus, the sample should be cooled sufficiently below the triple point to determine the heat capacity of the system (sample, vessel, and thermometers) from about 5 K to 20 K below (depending on the gas) to about 20 K above the triple point, and to determine the heat of fusion of the sample during the same series of measurements [41,47]. (Note: check thermometers must be calibrated along with the test thermometers. The measurements on the check thermometers will serve to guide the heating process during the calibration, as well as to provide measurement statistics.)

After cooling to the required low temperature, the vessel should be thermally isolated by placing it under continuous adiabatic control. Then the following series of measurements should be performed:

1. the equilibrium temperature should be observed with the check thermometer,
2. a measured amount of electrical energy should be added to the system,
3. a new equilibrium temperature should be established and measured,
4. steps 2 and 3 should be repeated until three heat capacity points are obtained below the triple point,
5. then, the sample should be completely melted by introducing a measured amount of heat,
6. next, the equilibrium temperature just above the triple point should be measured,
7. then, three additional heat capacity points should be obtained above the triple point in accordance with steps 2 and 3.

From the knowledge of the eight equilibrium temperatures (four below the triple point and four above the triple point) and the measured amounts of electrical energies added, the heat capacities of the system below and above the triple point, and the heat of fusion, are calculated. If Q joules are added to the system from an initial equilibrium temperature T_i just below the triple point to heat the system to a final equilibrium temperature T_f just above the triple point, the heat of fusion L is:

$$L = Q - C_s(T_o - T_i) - C_l(T_f - T_o), \quad (38)$$

where C_s and C_l are the mean heat capacities in the temperature intervals in the solid and liquid phases, respectively, and T_0 is the triple-point temperature.

For calibration of SPRTs, the sample should be completely frozen for the second time and the temperature set at about 1 K below the triple point, the sample thermally isolated, and the equilibrium temperature measured. From the knowledge of the previously determined heat capacity of the system below the triple point and of the heat of fusion, add enough electrical energy to melt about 10% of the sample. If T_1 is the initial equilibrium temperature just below the triple point, the required amount of electrical energy Q_1 to melt 10% of the sample is:

$$Q_1 = 0.1L + C_s(T_0 - T_1). \quad (39)$$

Once the system comes to equilibrium, measure the resistances of all of the thermometers. Repeat the measurements at 20%, 40%, 60%, 70%, and 80% melted. If the sample is about 99.9999% pure, all measurements on each thermometer throughout this melted range should agree to within 0.1 mK to 0.2 mK.

In using a temperature fixed point, one must make corrections for the hydrostatic head of the liquid and for the gas pressure on the defined equilibrium state. Table 6 gives the dT/dp for the defining fixed points of the ITS-90, both in terms of the external gas pressure to which the fixed-point material is exposed and in terms of the column of liquid.

3.2.2.2.1 TRIPLE POINT OF EQUILIBRIUM HYDROGEN, 13.8033 K (-259.3467 °C)

Hydrogen gas samples of 99.9999% and higher purity are readily available. [The first cryoscopic constant of hydrogen is relatively high (0.0740/K). Consequently, the liquidus point of an ideal hydrogen solution of 99.9999% purity would be approximately 0.01 mK lower than that of 100% pure hydrogen. Except for helium and deuterium, all other impurities would be either frozen or in solution in very small amounts.] The commonly used catalyst for converting ortho hydrogen to para hydrogen is hydrated ferric oxide ($\text{Fe}_2\text{O}_3 \cdot \text{H}_2\text{O}$ or $\text{FeO} \cdot \text{OH}$). Other oxides of magnetic elements, either pure or mixed-metal, such as those of chromium, nickel, cobalt, and neodymium, also have been used as catalysts for ortho to para hydrogen conversion. The hydrated ferric oxide catalyst is prepared by mixing at about 30 °C relatively dilute solutions (about 2 molal) of ferric chloride and sodium hydroxide, with only a slight excess of sodium hydroxide, washing the resulting gelatinous $\text{Fe}(\text{OH})_3$ precipitate thoroughly with distilled water, air drying at 140 °C for 24 hours, vacuum baking at 110 °C for 16 to 20 hours, and back-filling with hydrogen while the catalyst is still hot [7,104]. The catalyst is activated by flowing hydrogen through it for about 4 hours while the catalyst is maintained at a temperature of about 150 °C. The sample vessel and ancillary components should be designed to permit the whole of the hydrogen sample to come into contact with the catalyst at the equilibrium temperature. See references [2,31,58].

3.2.2.2.2 TRIPLE POINT OF NATURAL NEON, 24.5561 K (-248.5939 °C)

Neon gas samples of 99.999% purity are commercially available. Samples of higher purity may be obtained by special arrangement with the supplier. The

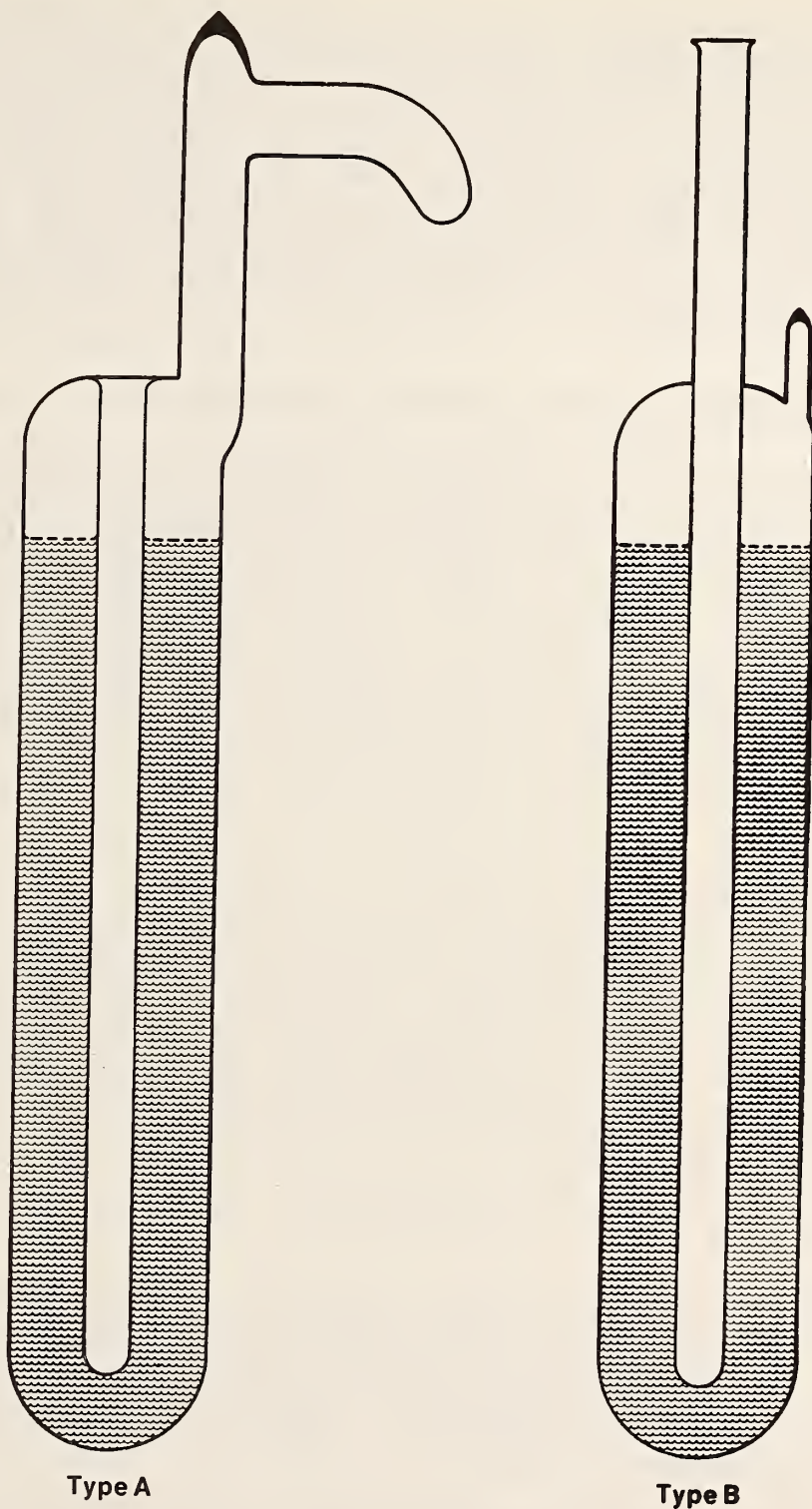

Figure 6. Two types of triple point of water cells with wells for platinum resistance thermometers. The cells contain pure air-free water. The thermometer wells are made of precision-bore tubing.

principal impurities are CO, H₂, He, and N₂. The CO and the N₂ impurities can be frozen out by slowly flowing the sample through a coiled tube immersed in liquid neon; the H₂ and the He impurities can be removed by freezing the neon sample in liquid hydrogen and pumping, with care so that the lighter isotopes of neon are not preferentially removed. [The first cryoscopic constant of neon is 0.0668/K. Consequently, the liquidus point of an ideal neon solution of 99.999% purity would be approximately 0.1 mK lower than that of 100% pure neon.] The purified sample should be collected in a clean stainless-steel cylinder by cooling the cylinder in liquid hydrogen (or cooled with liquid helium). If desired, the purified sample can be collected directly in the cooled sample vessel. See references [1,79].

3.2.2.2.3 TRIPLE POINT OF OXYGEN, 54.3584 K (-218.7916 °C)

Oxygen gas samples of 99.999% purity are commercially available. Accurate chemical analysis of oxygen is difficult and, therefore, the claimed purity may not be correct. Unknown or undetected impurities are chemically less reactive than oxygen, e.g, the noble gases, and, in particular, argon, which forms a peritectic with oxygen. Samples of purity greater than 99.999% may be obtained by special arrangement with the supplier. [The first cryoscopic constant of oxygen is 0.0181/K. Consequently, the liquidus point of an ideal oxygen solution of 99.999% purity would be approximately 0.6 mK lower than that of 100% pure oxygen.] Careful preparation by thermal decomposition of potassium permanganate can yield samples of 99.9999% purity or better [47]. The oxygen sample should be stored in clean stainless-steel cylinders. See references [32,47,59,79,80].

3.2.2.2.4 TRIPLE POINT OF ARGON, 83.8058 K (-189.3442 °C)

Argon gas samples of 99.9999% purity or better are readily available. The usual impurities are the components of air, moisture, and hydrocarbons. [The first cryoscopic constant of argon is 0.0203/K. Consequently, the liquidus point of an ideal argon solution of 99.9999% purity would be approximately 0.05 mK lower than that of 100% pure argon.] To fill the sample vessel, the gas may be used directly or it may be dried first by slowly passing it through a coiled tube immersed in either liquid oxygen or a Dry Ice/ethyl alcohol mixture. See references [17,41,42,59,79,80].

3.2.3 TRIPLE POINT OF WATER, 273.16 K (0.01 °C)

The triple-point temperature of water is assigned the value 273.16 K on the Kelvin Thermodynamic Temperature Scale and also on the ITS-90. It is the reference temperature for resistance ratios in platinum resistance thermometry. The water used in preparing triple point of water cells is pure water of naturally-occurring isotopic composition. Figure 6 shows two commonly used types of triple point of water cells.

Triple point of water cells are usually prepared from river water that has been purified by chemical treatment and distillation. River water is expected to have concentrations of deuterium and the heavier isotopes of oxygen that are lower than that of ocean water. The extreme difference in the triple points of naturally-occurring water, including polar water, is given as 0.25 mK [100].

It is expected that differences among water triple-point cells of river water would be much smaller than 0.25 mK. (The isotopic composition difference between river water and ocean water [100] has been estimated to cause no more than a 0.050 mK difference in the triple-point temperature.) While the basic material is plentifully available, preparation of water triple-point cells requires a special effort [5,40]. Although the effect on the triple-point temperature is negligible, a trace of air always remains in most sealed triple point of water cells. When a cell at room temperature is gently inverted from one end to the other and a sharp "click" is produced through the water hammer action, the amount of gas in the cell will have negligible influence on the triple-point temperature.

3.2.3.1 REALIZATION AND APPLICATION OF THE TRIPLE POINT OF WATER

In preparation for producing an ice mantle that is required for realizing the triple-point temperature of water, the thermometer well of the cell is wiped thoroughly dry, sealed with a rubber stopper, and the cell placed in an ice bath to cool to a few degrees above the ice point. When the cell has been cooled in this manner, an ice mantle of fairly uniform thickness can be obtained. Withdraw the cell from the ice bath, set it upright on a stand, and place one drop of ethyl alcohol at the bottom of the well. Introduce small amounts of crushed Dry Ice into the bottom of the well and continue to do so until a thick mantle is formed at the bottom. Then, fill the well with crushed Dry Ice to the water level of the cell. Continue to add crushed Dry Ice to the well so as to maintain the level of Dry Ice at the water level. If the Dry Ice level becomes low before more is added, the ice mantle may crack. If the cell were precooled as indicated above, a solid ice bridge may form at the water level. If such a bridge forms, melt it immediately with heat from the hands while gently shaking the cell. The solid ice bridge can completely seal the cell at the top and any subsequent formation of ice could produce enough pressure to rupture the glass cell. When a mantle of approximately the desired thickness (4 to 8 mm) is formed, stop adding Dry Ice, replace the cell in the ice bath with the well opening slightly above the water surface of the ice bath, and leave the cell there until all of the Dry Ice evaporates. Then, fill the well with ice water and store the cell in an ice bath or ice pack for a day before using it. When the ice mantle is frozen by using Dry Ice, a process that usually requires less than one hour, the strains in the ice cause the "triple-point temperature" to be about 0.2 mK low. These are removed by letting the mantle anneal for one day.

Other methods can be used also to prepare the ice mantle. With ethyl alcohol in the thermometer well, any "cold finger" technique can be used. This technique includes successively inserting liquid nitrogen cooled rods, using a closed-end tube containing crushed Dry Ice, or using a heat-pipe cooler. These methods require more time to freeze the mantle, but the strain produced in the ice will be less than those produced by the Dry Ice technique.

After the strains in the ice mantle have been relieved by storing the cell in an ice bath for at least one day, insert momentarily a glass rod into the well in order to melt a thin layer of ice next to the well. This forms an ice-water interface immediately adjacent to the thermometer well. The test for this "inner melt" is made by giving the cell a rotatory impulse to determine whether

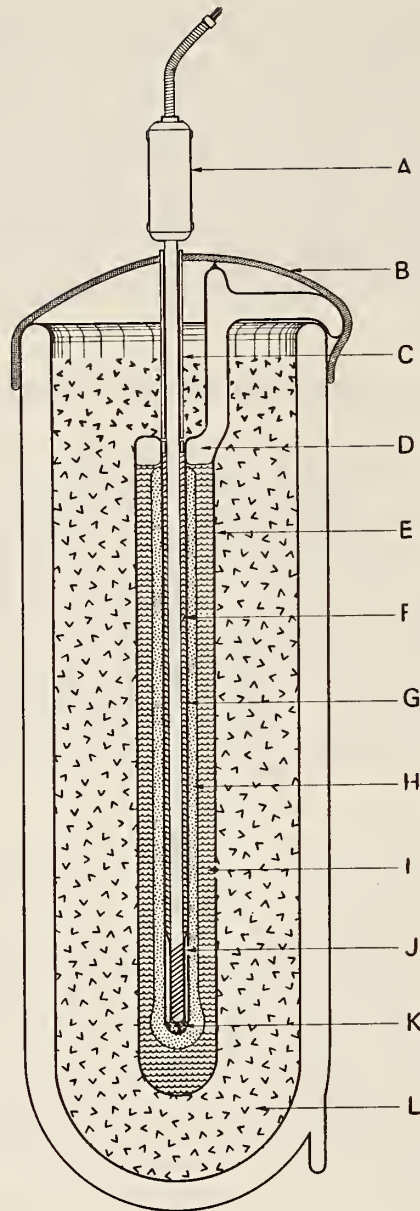

Figure 7. An SPRT in a Type A triple point of water cell immersed in an ice bath.

A -- platinum resistance thermometer, B -- heavy black felt to shield against ambient radiation, C -- polyethylene tube for guiding the SPRT into the thermometer well (the tube has a small hole near the top of the thermometer well to allow water, but not ice, to enter the tube.), D -- water vapor, E -- borosilicate glass cell, F -- water from the ice bath, G -- thermometer well (precision bore glass), H -- ice mantle, I -- air-free water, J -- aluminum bushing with internal taper at the upper end to guide the SPRT into its close-fitting inner bore, K -- polyurethane sponge for cushioning the SPRT, L -- finely divided ice and water.

the ice mantle rotates freely about the axis of the thermometer well. The outer ice-water interface guards and thermally stabilizes the inner ice-water interface temperature that is measured with the SPRT.

Figure 7 shows a triple point of water cell immersed in an ice bath with an SPRT inserted into the thermometer well. An SPRT should be precooled in a glass tube of water in an ice bath before it is inserted into the triple-point well so that the thickness of the water layer next to the thermometer well will not become excessive. Also, the time required for the SPRT to come into thermal equilibrium will be shortened. Heavy felt cloth should be used to cover the ice bath in order to prevent ambient radiation from entering the bath and reaching the thermometer element, which otherwise would cause the thermometer to give a slightly high (erroneous) reading. A plastic foam cushion should be placed at the bottom of the thermometer well to protect the well and the SPRT. Since water is a poor thermal conductor, a close fitting aluminum sleeve should be used to enhance the thermal conduction.

The thermometer current should be imposed immediately after insertion of the SPRT into the cell so that readings can be made under conditions of steady-state self heating. Five to ten minutes or longer may be required before steady-state conditions are reached. To avoid errors due to variations in the self heating that arise from variations in the thermal contact of the thermometer with its surroundings, it is best to read the SPRT at two currents and extrapolate the readings to zero power in the SPRT.

3.2.4 FREEZING, MELTING, OR TRIPLE POINTS OF METALS: Hg, Ga, In, Sn, Zn, Al, Ag, Au, or Cu

The realization of metal fixed points requires the continuous presence of liquid-solid or liquid-solid-vapor phases in thermal equilibrium. With SPRTs, the liquid-solid interface, i.e., the equilibrium whose temperature is measured, must surround and must be as close to the temperature sensing element as possible. Since the first cryoscopic constants of metals are relatively low, the fixed-point metal samples should be at least 99.9999% pure. Figure 8 shows idealized liquid/solid equilibrium conditions inside fixed point cells used in freezing and melting experiments. Figure 9 shows a representative arrangement of an SPRT inserted inside a metal fixed point cell. Ideally, and similar to the water triple-point cell, an outer liquid-solid interface, which completely surrounds the inner interface, exists close to the container wall. This outer interface, which has a temperature very close to that of the inner interface, thermally protects and thermally stabilizes the inner interface. In freezing experiments, a layer of solid is first formed at the crucible wall, then a thin layer of solid is induced on the thermometer well by inserting cooling rods. As freezing advances, the outer interface approaches the inner interface until all of the material is solid. In melting experiments, a layer of liquid is first formed next to the crucible, then a thin layer of liquid is formed next to the thermometer well by inserting a warming rod or a long heater. As melting advances, the outer liquid/solid interface approaches the inner interface.

Since different furnace or bath designs are required for fixed-point cells operated at different temperatures, they will be discussed along with each of the fixed points, or references will be made to appropriate sources of

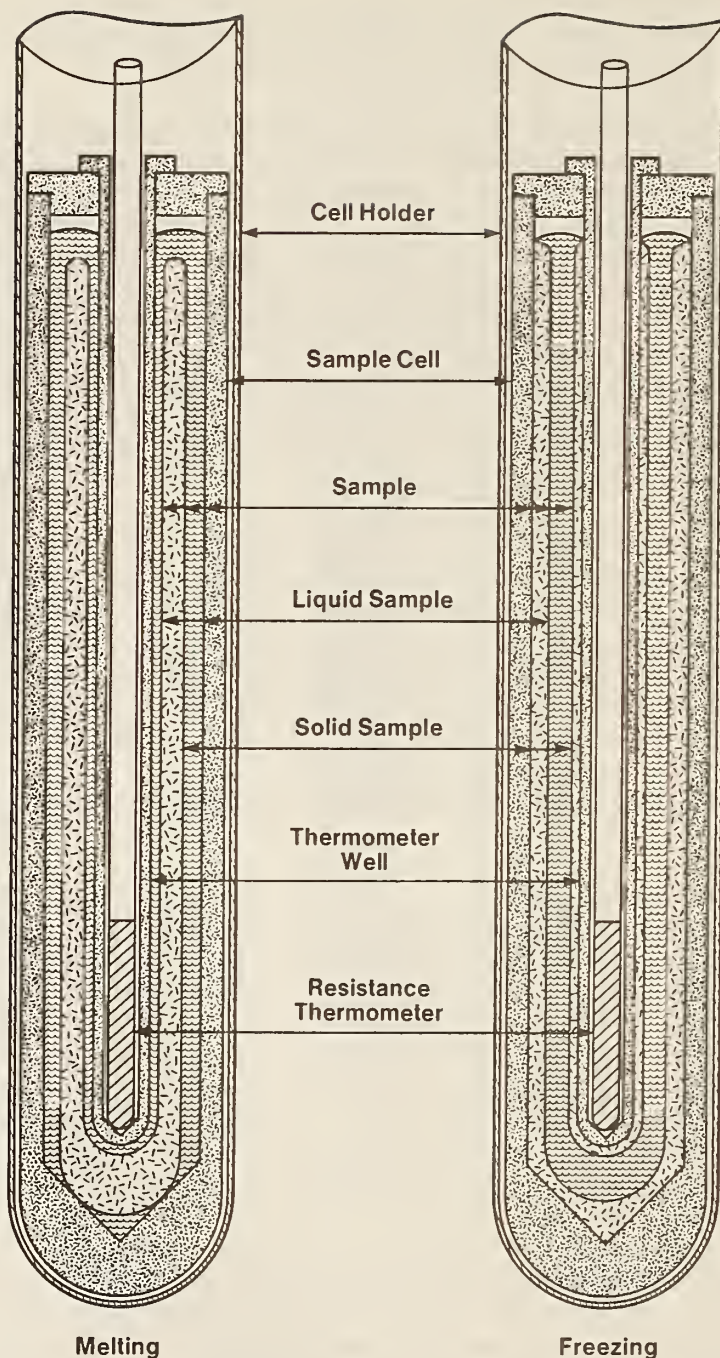

Figure 8. Idealized liquid/solid equilibrium conditions inside fixed point cells used in freezing and melting experiments. In freezing experiments, a layer of solid is first formed at the crucible wall, then a thin layer of solid is induced on the thermometer well by inserting cooling rods. In melting experiments, a layer of liquid is first formed next to the crucible, then a thin layer of liquid is formed next to the thermometer well by inserting a warming rod or a long heater. As melting advances, the outer liquid/solid interface approaches the inner interface.

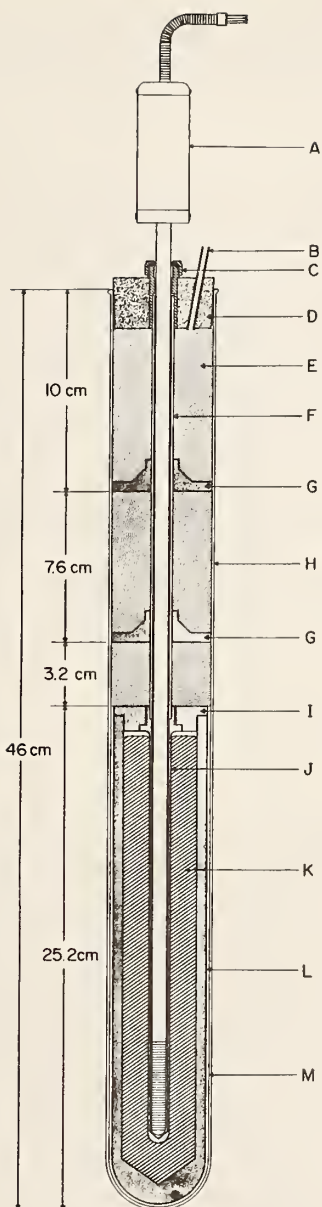

Figure 9. An SPRT in a metal freezing-point cell.

A -- platinum resistance thermometer, B -- to helium gas supply and pressure gauge, C -- thermometer gas seal with silicone rubber, D -- silicone rubber stopper, E -- thermal insulation (washed Fiberfrax), F -- thermometer guide tube [precision bore tube, ground (matt finish) to uniform outside diameter], G -- heat shunt (graphite) in close contact with F and with H, H -- borosilicate glass cell [precision bore tube ground (matt finish) to uniform outside diameter], I -- graphite cap (lid) for the graphite crucible, J -- graphite thermometer well, K -- metal sample, L -- graphite crucible, M -- thermal insulation (Fiberfrax paper) between the graphite crucible and the borosilicate glass cell.

descriptions.

In radiation thermometry, the liquid-solid phase of the metal fixed point must completely surround the blackbody radiator cavity.

3.2.4.1 CONTAINER MATERIAL

Containers for the fixed-point metals must not contaminate the metal sample, and the container material must be rugged enough to retain its integrity under thermal cycling between the temperature of use and ambient temperature. The container material preferably should be inert to air at temperatures of use; if not, e.g., graphite above about 200 °C, the container plus the fixed-point material must be protectively enclosed in an inert gas, such as nitrogen, argon, or helium, using either a borosilicate or fused silica glass envelope. It should be assumed that the fixed-point material itself will react chemically with air and, thus, the material must be protected.

3.2.4.2 METAL FIXED POINT DEVICES FOR CALIBRATING SPRTs

Figure 9 shows a representative fixed-point cell that can be used for calibrating long-stem type SPRTs. In the following sections, individual types will be described.

3.2.4.2.1 MERCURY TRIPLE POINT

3.2.4.2.1.1 MERCURY SAMPLE

On the ITS-90, the triple point of mercury (equilibrium phase state of mercury solid, liquid, and vapor phases) is assigned the value 234.3156 K (-38.8344 °C). Depending upon the choice of container material and operating procedure, it may be more practical to realize the mercury freezing point at one standard atmosphere, the value being 234.3210 K (-38.8290 °C). Mercury samples with impurity content of 1 part in 10^8 or less can be prepared by potassium hydroxide and nitric acid washings, followed by triple distillation [48]. The alkali and acid washings can be carried out by vigorously bubbling clean filtered air through the mixture of mercury and the alkali or the acid. To remove any remaining oxidizable impurities, the first two distillations should be carried out under reduced pressures with a fine stream of clean filtered air bubbling into the mercury in the distillation container. The third distillation should be done under high vacuum to remove the noble metals. With the high-purity mercury (99.999999%), both freezing and melting techniques give triple-point temperatures that agree to within ± 0.1 mK over most of the liquid-solid range. [The first cryoscopic constant of mercury is 0.00503/K. Consequently, the liquidus point of an ideal mercury solution of 99.999999% purity would be approximately 0.002 mK lower than that of 100% pure mercury.]

3.2.4.2.1.2 CONTAINERS FOR MERCURY

Any container material can be used with mercury that is sufficiently rigid and does not dissolve in, or chemically react with, mercury in the temperature range of storage and application. The choice will depend upon whether the mercury fixed-point cell is to be used at its triple point, at its freezing point, or

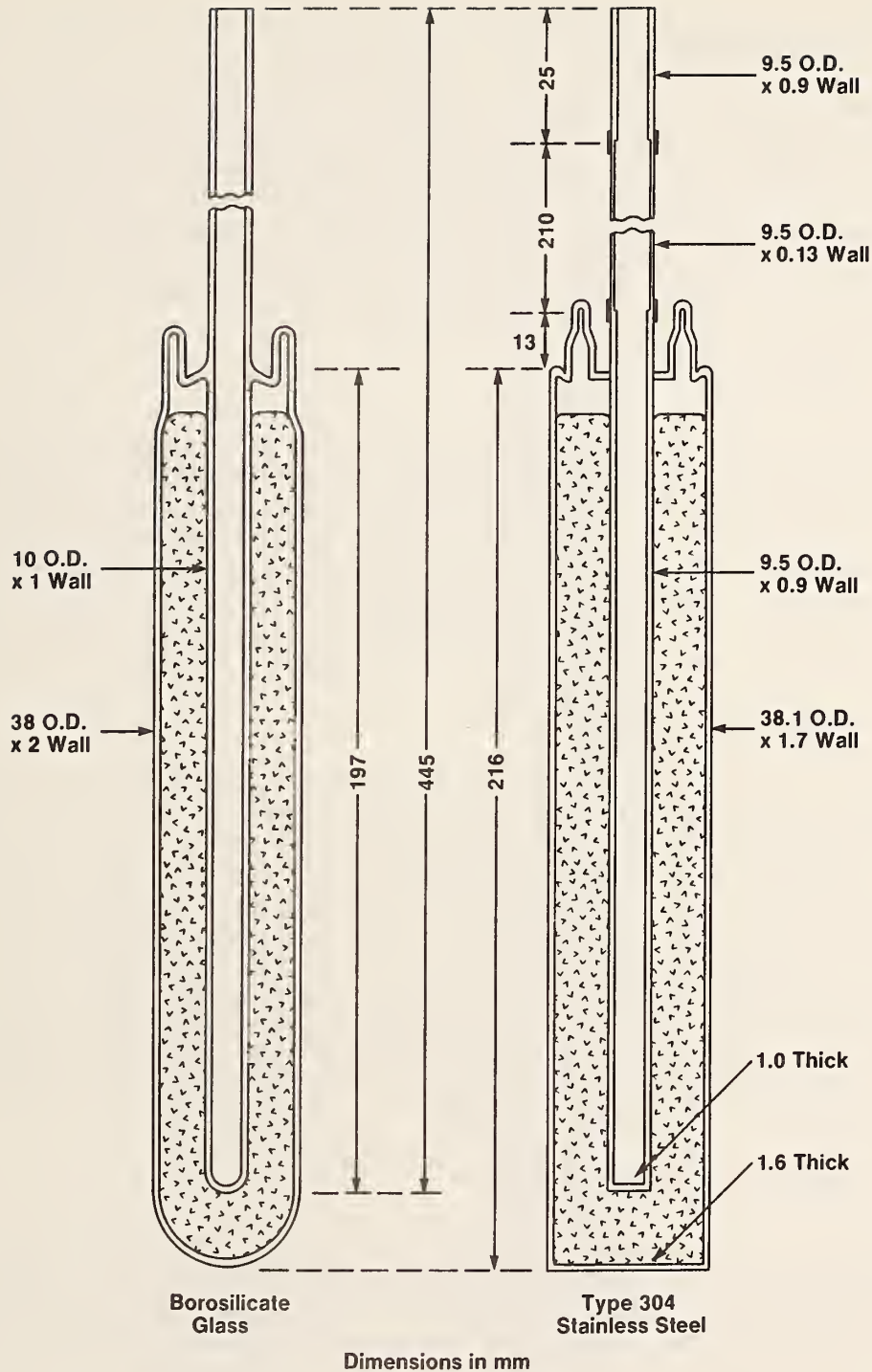

Figure 10. Two mercury triple-point cells, one constructed of borosilicate glass and one of Type 304 stainless steel. The two small-diameter tubes at the top facilitate the cleaning of the cells before filling and sealing. The glass cell is sealed by melting the small-diameter tubes, but the stainless steel cell is sealed by pinching flat the small-diameter tubes and electric-arc welding them, thereby severing them at the middle of the flat.

at either one.

3.2.4.2.1.3 METAL CONTAINERS

Mercury is capable of dissolving most metals, at least at the low levels of impurity content (<1 ppm) that are the permitted maxima for metal fixed points. Iron, nickel, chromium, and tantalum have been reported to be soluble at only 1 ppm or less; hence, stainless steel is an adequate container for mercury in most temperature standard applications [53,103]. (Note: the solubility of nickel in mercury may be close to the limit of 1 ppm.) Mercury triple-point cells can be prepared by pinching and welding the small diameter tubes used for cleaning, evacuating, and filling (see fig. 10).

3.2.4.2.1.4 CONTAINERS OF GLASS

It is expected that some metal impurities in glasses [single metal oxide (e.g., fused silica glass) or mixed metal oxides (e.g., borosilicate glass)] or "ceramics" can be leached out by mercury when the mercury is stored in them for many years. Traditionally, "soft glass" has been considered suitable for storing mercury [48]; however, soft glass, without special treatment, may be susceptible to breakage when thermally shocked. Borosilicate glass and fused silica glass are more practical choices for mercury containers. Figure 11 shows a borosilicate glass mercury triple-point cell inside a stainless steel holder.

3.2.4.2.1.5 CONTAINERS OF PLASTIC

Organic plastics, such as polyethylene, polytetrafluoroethylene (Teflon), or polytrifluorochloroethylene (Kel-F), all of which are free of metals, can be used to contain mercury and be used at the mercury freezing point. A stainless steel holder similar to that used for the glass mercury cell and for the stainless steel mercury cell (see fig. 11) or similar to the holder used for the indium cell (see fig. 12) could be used as the external holder for a plastic mercury cell. Although plastic cells have not been used yet in preparing mercury fixed-point cells, it would be practical and desirable to use plastic cells for realizing the mercury fixed point. Since the vapor pressure of mercury at room temperature is sufficiently high that mercury vapors can be transported under vacuum conditions, the vapors should be confined by an atmosphere of helium or other inert gases.

3.2.4.2.1.6 ASSEMBLY OF MERCURY CELLS

A purified mercury sample can be vacuum distilled into glass containers, with the glass filling tube then sealed under vacuum with a flame [43]. The mercury sample may be vacuum distilled into stainless steel containers and the filling tube pinched, and then cut and sealed using electric-arc welding techniques [43].

3.2.4.2.1.7 REALIZATION AND APPLICATION

When the total impurity content of a mercury sample is about one part in 10^8 , both freezing and melting techniques yield triple-point temperatures agreeing to within ± 0.1 mK over most of the liquid-solid range. A dual-stage

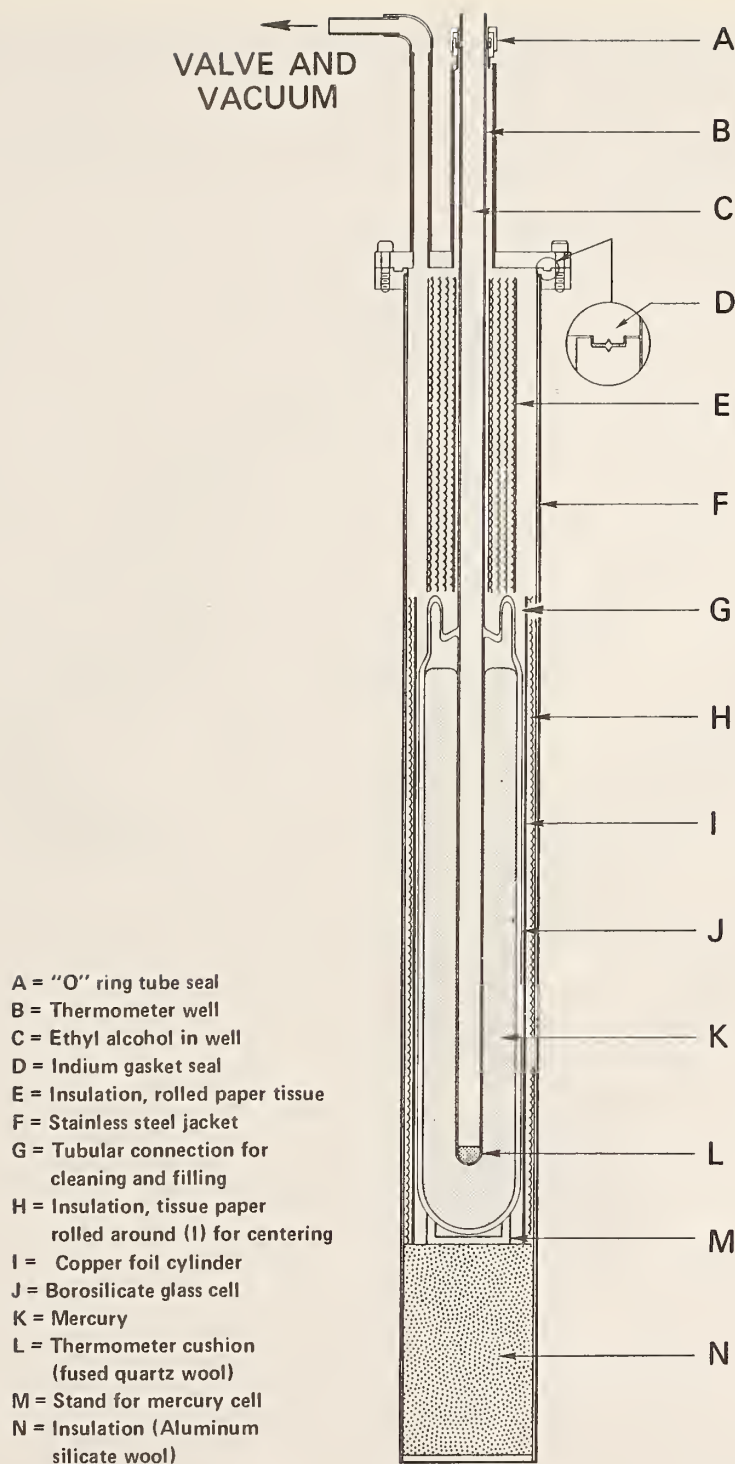

Figure 11. A borosilicate glass, mercury triple-point cell in a stainless steel container. A stainless-steel, mercury triple-point cell may also be mounted inside the stainless steel container. With the high-purity mercury sample, both freezing and melting techniques yield triple-point values agreeing to within ± 0.1 mK over most of the liquid-solid range.

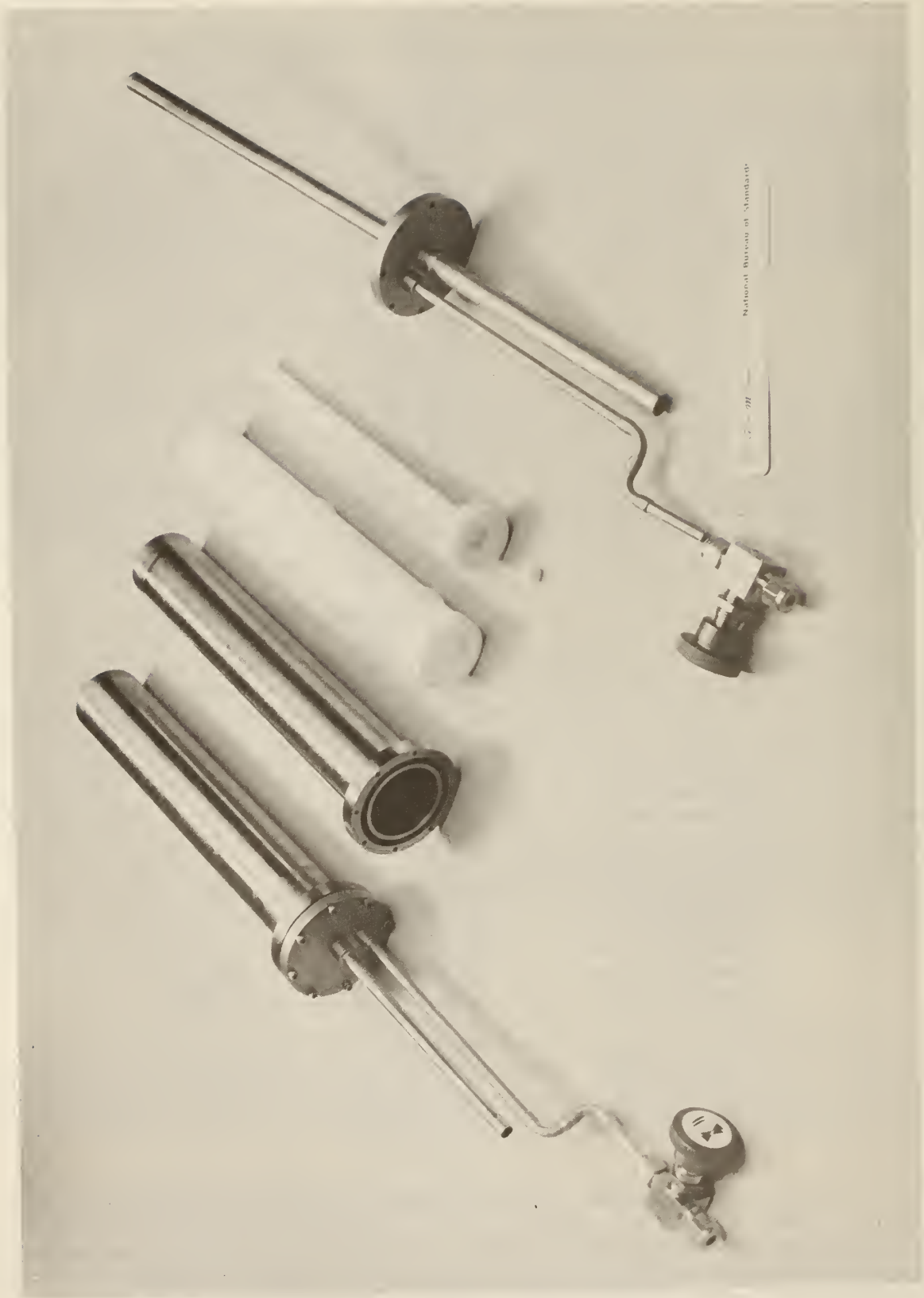

Figure 12. Photograph of an all-plastic indium cell and its stainless steel container.

refrigerator can yield a temperature near $-40\text{ }^{\circ}\text{C}$ and, hence, could be used for freezing mercury, but a much simpler stainless steel vacuum enclosure placed in a Dry Ice/ethyl alcohol mixture ($-78\text{ }^{\circ}\text{C}$) can reduce the freezing rate of mercury to give a freeze duration of about 10 hours or more with 2.2 kg of mercury, and that is perfectly adequate. Figure 11 shows such a stainless steel enclosure that has been used with a borosilicate-glass mercury cell at the NIST.

To start a freeze, fill the stainless steel enclosure that contains the mercury triple-point cell with dry air and immerse it in a Dry Ice/ethyl alcohol bath. Fill the thermometer well with ethyl alcohol and insert therein an SPRT for monitoring the temperature of the cell. Usually, mercury supercools about $6\text{ }^{\circ}\text{C}$ in a borosilicate glass cell but only about $3\text{ }^{\circ}\text{C}$ in a stainless steel cell. When recalescence is observed, evacuate the stainless steel holder. Remove the monitoring SPRT from the well and replace it with a thin-wall stainless steel tube that contains ethyl alcohol and that has been cooled in a tube of ethyl alcohol immersed in a Dry Ice/ethyl alcohol bath. Insert successively into the stainless steel tube two or three liquid-nitrogen cooled glass rods, for about 5 minutes each, in order to freeze a thin layer of mercury around the thermometer well. The purpose of the stainless steel tube is to collect the frost that forms on the rods when they are removed from the liquid nitrogen. Remove the stainless steel tube and replace it with the monitoring SPRT, which has been cooling in the tube of cold ethyl alcohol. Switch on the thermometer measuring current. (Note: it may be necessary to refill the thermometer well with a small amount of cold ethyl alcohol from the Dry-ice cooled tube before the monitoring SPRT is inserted into the well. The well should be completely filled with ethyl alcohol when the SPRT is in the well.) With the induced inner freeze around the thermometer well, temperature equilibrium is reached in about 5 minutes. After the resistance of the monitoring SPRT is read, other cooled SPRTs are successively inserted into the mercury cell and calibrated. The final reading in a cell is made with the monitoring SPRT in order to check the extent of the freeze. This final reading of the monitoring SPRT must agree with the initial reading to within $\pm 0.1\text{ mK}$. See reference [43] for more details on the calibration procedure at the mercury triple point.

3.2.4.2.2 MELTING POINT OF GALLIUM

The melting point of gallium is assigned a temperature of 302.9146 K ($29.7646\text{ }^{\circ}\text{C}$) on the ITS-90. Gallium of 99.99999% purity can be obtained commercially. At such high purity, both freezing and melting techniques should yield liquid-solid equilibrium temperatures that agree to within $\pm 0.1\text{ mK}$. Since the metal expands about 3% on freezing, plastic containers, such as polyethylene, polypropylene, or polytetrafluoroethylene, are the most suitable. These are sufficiently flexible at around $30\text{ }^{\circ}\text{C}$ to accommodate the volume change in the gallium. In assembling the gallium fixed-point cell, the supercooled metal can be poured directly into the container. A second more rugged container of Nylon, glass, or stainless steel should enclose the flexible container so that the pressure of the inert gas over the metal can be controlled at one atmosphere or be evacuated to observe the triple point. A gallium fixed-point cell, consisting of an all plastic container, that is used at the NIST is shown in figure 13. Since gallium supercools as much as $25\text{ }^{\circ}\text{C}$ to $70\text{ }^{\circ}\text{C}$, depending upon the plastic material that is in contact with it, the most convenient method of observing its liquid-solid equilibrium temperature is the melting technique. [The first

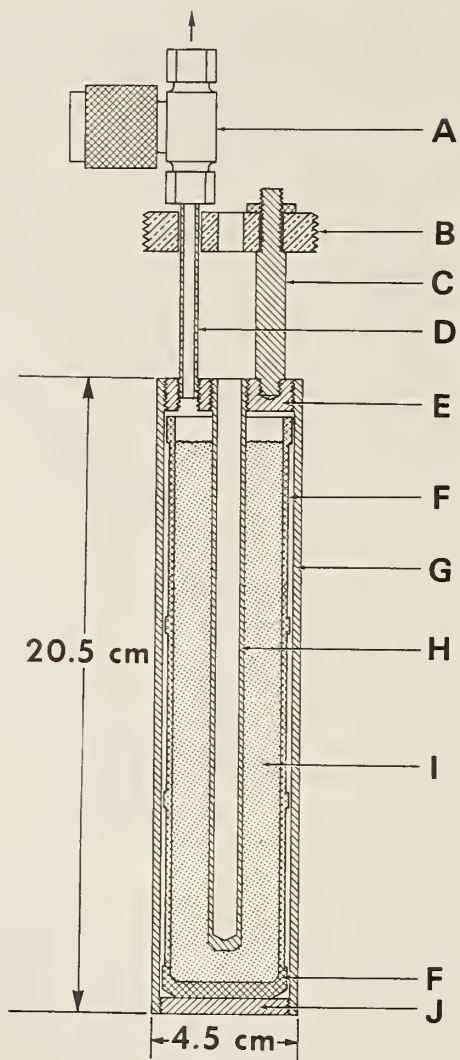

Figure 13. An all-plastic gallium melting/triple-point cell. The triple point is realized by using the melting technique. The cell is periodically evacuated through the valve.

A -- valve (Zytel), B -- bath lid (Plexiglas), C -- support rod (Nylon), D -- pumping tube (polyethylene), E -- cap (Nylon), F -- sample container (Teflon), G -- case (Nylon), H -- thermometer well (Nylon), I -- gallium metal, J -- base of the case (Nylon).

cryoscopic constant of gallium is 0.00732/K. Consequently, the liquidus point of an ideal gallium solution of 99.9999% purity would be approximately 0.01 mK lower than that of 100% pure gallium.]

3.2.4.2.2.1 REALIZATION AND APPLICATION

In order to solidify the gallium metal in a fixed-point cell, initially in the supercooled state (e.g., at room temperature), first insert successively two or three liquid-nitrogen-cooled copper rods into the thermometer well of the cell to induce nucleation, and then place the cell in an ice bath for about one hour or longer. The cell with the solidified gallium may then be placed in an oil bath at a temperature of about 40 °C to partially melt the sample to form an outer liquid-solid interface. To form a liquid-solid interface next to the thermometer well (an inner melt), the bath oil may be circulated through the thermometer well by pumping the oil through a tube placed in the well. After about 20 minutes in the hot oil bath, about 25% of the gallium will be melted. The inner liquid-solid interface can also be prepared by using an electric heater in the well. The amount of electric energy required, e.g., to form about a 1 mm shell of liquid around the thermometer well, can be calculated from the outer dimensions of the thermometer well and the heat of fusion of gallium (see table 7). The gallium cell is then securely mounted, completely immersed so that the thermometer well will be filled with the bath oil, in a stirred oil bath, controlled at a temperature about 10 mK above the liquid-solid equilibrium temperature (melting point or the triple point). Also, the cell can be immersed in a fairly close-fitting, oil-filled aluminum or copper block, controlled at a temperature about 10 mK above the equilibrium temperature. The monitoring SPRT is heated and then inserted into the thermometer well of the gallium cell. Readings are taken after about 20 minutes of equilibration in the cell. The monitoring SPRT is replaced in the cell with a preheated test SPRT and measurements on it are made after about 20 minutes. A number of SPRTs can be successively calibrated in the same "melt". When all of the test SPRTs have been calibrated, a final measurement in the cell is made on the monitoring SPRT. This reading of the monitoring SPRT should agree with the initial reading to within ± 0.1 mK. Also, measurements with different melts should agree to within ± 0.1 mK. See references [16,26,65,68,94].

3.2.4.2.3 FREEZING POINT OF INDIUM

The freezing point of indium is assigned the value 429.7485 K (156.5985 °C) on the ITS-90. Metal samples of 99.9999% purity and higher are commercially available. The freezing point of indium is at a sufficiently low temperature to permit the use of containers of high temperature plastics [polytetrafluoroethylene (Teflon), polyimide/amide, and others], borosilicate glass, and stainless steel [4,69,74,92]. See figure 14 for an example of a Teflon container used for indium at the NIST. As used with metals that freeze at higher temperatures, graphite can also be used with indium. The metal is available in the form of small pellets, wire, and rods. Suitable amounts for a sample can be easily weighed into the container. [The first cryoscopic constant of indium is 0.00212/K. Consequently, the liquidus point of an ideal indium solution of 99.9999% purity would be approximately 0.5 mK lower than that of 100% pure indium.]

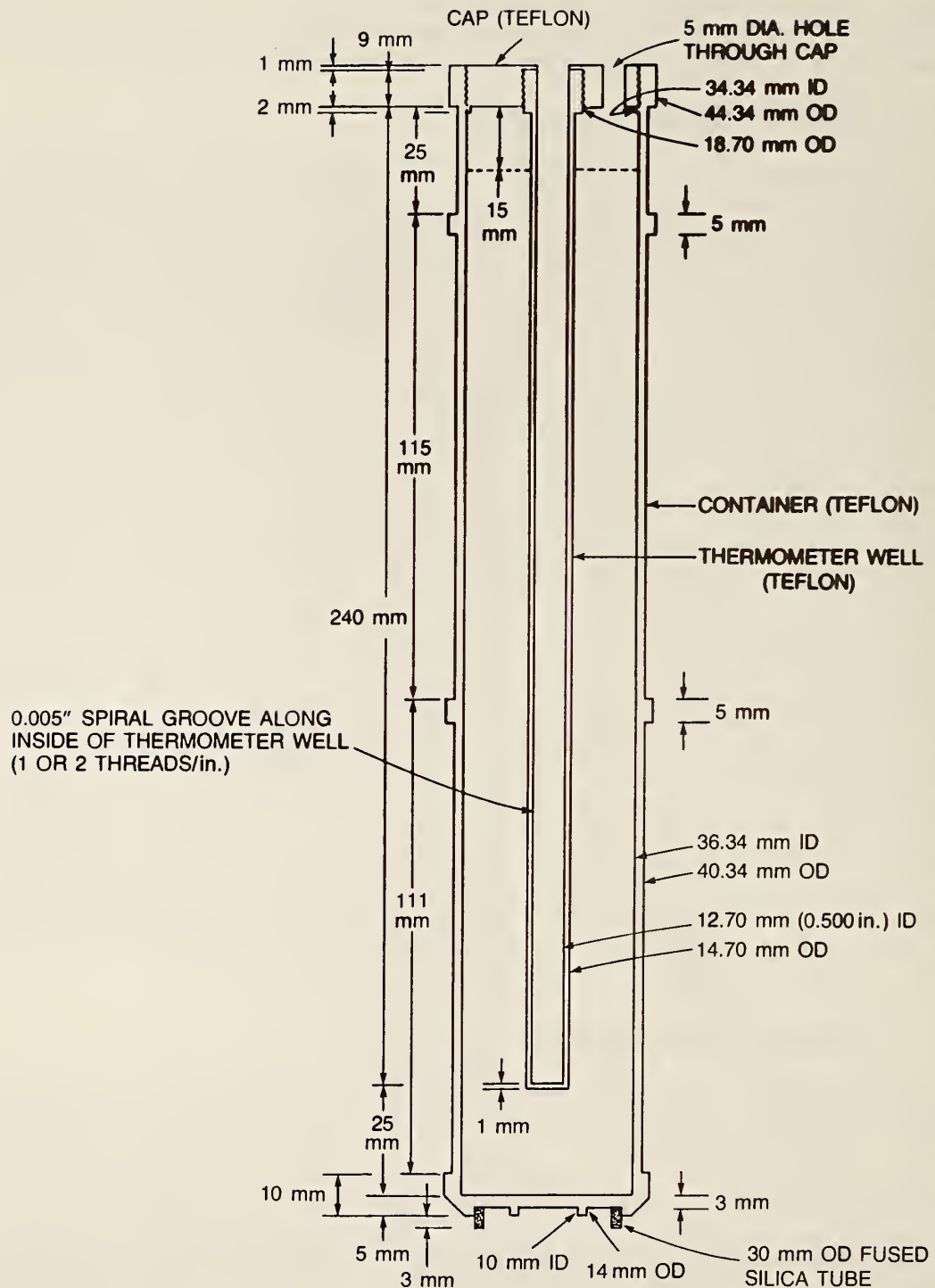

Figure 14. An all-plastic indium freezing-point cell to be used in a stainless steel container, such as that shown in figure 12. The argon gas pressure inside the stainless steel container is adjusted to one atmosphere at the freezing point. A similar all-plastic cell and stainless steel container may be used to realize the mercury freezing point or melting point at one atmosphere.

3.2.4.2.3.1 REALIZATION AND APPLICATION

A tube furnace containing the indium-point cell is controlled about 5 °C above the freezing point of indium until the metal is completely melted. (It is convenient to control the furnace temperature automatically and melt the metal sample overnight so that the freezing of the metal may be started in the morning.) Insert the check SPRT into the cell well and when the SPRT indicates that the sample is about 5 °C above the freezing temperature, change the furnace temperature control settings to control at 5 °C below the freezing point. When the check SPRT indicates recalescence, change the furnace temperature control settings to control at 1 °C to 0.5 °C below the freezing point. Withdraw the check SPRT from the cell well and insert successively in the well two fused silica glass rods, each initially at room temperature, for about 5 minutes each and then insert the cool check SPRT in order to freeze a thin mantle around the thermometer well. (To avoid the consequence of inserting borosilicate glass rods into the aluminum or silver point cell to form the mantle around the thermometer well, all glass rods used for this purpose in the laboratory should be fused silica glass.) Within 20 to 30 minutes, the readings on the check SPRT should indicate that the cell is at temperature equilibrium. After the readings on the check SPRT are completed, test SPRTs, that have been heated in an auxiliary furnace, are successively inserted into the cell well and calibrated. After all of the test SPRTs have been calibrated, the preheated check SPRT is inserted again into the cell well and read. This second reading should agree with the first to within ± 0.1 mK. See references [4,69,74,92].

3.2.4.2.4 FREEZING POINT OF TIN

The freezing point of tin is assigned the value 505.078 K (231.928 °C). Metal samples of 99.9999% purity are commercially available. Graphite containers are commonly and successfully used for tin. Although the use of materials such as boron nitride (BN) has not been reported, it could be a suitable container for tin. High purity tin has been found to supercool 25 °C or more [73,76]; hence, the freeze is nucleated by rapid cooling outside the furnace. The metal is available in the form of small pellets and in rods suitable for filling the graphite container. A method for filling graphite containers and installing the graphite thermometer wells is described in reference [46]. [The first cryoscopic constant of tin is 0.00329/K. Consequently, the liquidus point of an ideal tin solution of 99.9999% purity would be approximately 0.3 mK lower than that of 100% pure tin.]

3.2.4.2.4.1 REALIZATION AND APPLICATION

A tube furnace [46] containing the tin freezing-point cell is controlled about 5 °C above the freezing-point temperature until the metal is completely melted. (It is convenient to control the furnace temperature automatically and melt the metal overnight so that freezing of the metal can be started early in the morning.) Insert the check SPRT into the cell well and, when the SPRT indicates that the sample temperature is about 5 °C above the freezing point, change the furnace temperature control settings to control at 1 °C to 0.5 °C below the freezing point. When the check SPRT indicates that the cell temperature is close to the freezing-point value, withdraw the cell and the SPRT from the furnace. The cell will then cool rapidly and when the SPRT detects recalescence,

replace the cell in the furnace. Withdraw the check SPRT from the cell well. Insert successively in the well two fused silica glass rods, each initially at room temperature, for about 5 minutes each, and then the cool check SPRT in order to freeze a thin mantle around the thermometer well. Within about 20 to 30 minutes, the readings on the check SPRT should indicate that the cell is at temperature equilibrium. After the readings on the check SPRT are completed, test SPRTs, that have been heated in an auxiliary furnace, are successively inserted into the cell well and calibrated. After all of the test SPRTs have been calibrated, the check SPRT is heated and inserted again into the cell well and read. This reading should agree with the initial reading to within ± 0.1 mK. See references [43,46,73,76].

3.2.4.2.5 FREEZING POINT OF ZINC

The freezing point of zinc is assigned the value 692.677 K (419.527 °C). Metal samples of 99.9999% purity are commercially available. High purity liquid zinc has been found to supercool about 0.02 °C to 0.06 °C; hence, unlike the freezing procedure used with the tin-point cell, its freeze can be initiated in the furnace without withdrawing the cell from the furnace. Graphite containers are commonly and successfully used for zinc. Although the use of materials such as boron nitride (BN) has not been reported, it could be a suitable container for zinc. The metal is available in the form of small pellets and in rods suitable for filling graphite containers. [The first cryoscopic constant of zinc is 0.00185/K. Consequently, the liquidus point of an ideal zinc solution of 99.9999% purity would be approximately 0.5 mK lower than that of 100% pure zinc.]

3.2.4.2.5.1 REALIZATION AND APPLICATION

A tube furnace containing the zinc-point cell is controlled about 5 °C above the freezing point until the metal is completely melted. If the furnace temperature is maintained at a higher temperature, the zinc will melt faster, but the zinc should never be heated by more than about 5 °C above its melting point. (It is convenient to control the furnace temperature automatically and melt the zinc sample overnight so that the freezing of the metal can be started early in the morning and the calibration of six or more test SPRTs can be completed during the same day.) Insert the zinc-point check SPRT into the cell well. When the SPRT indicates that the melt is about 5 °C above the freezing point, change the furnace temperature control settings to control at 5 °C below the freezing point in order to initiate rapid cooling for nucleation. When the check SPRT indicates recalescence, change the furnace temperature control settings to control at 1 °C to 0.5 °C below the freezing point. Withdraw the check SPRT from the cell well and insert successively into the well two fused silica glass rods, each initially at room temperature, for about 5 minutes each, and then insert again the cool check SPRT. This freezes a thin mantle around the thermometer well. Within about 20 to 30 minutes, the readings on the check SPRT should indicate that the cell is at temperature equilibrium. After the readings on the check SPRT are completed, test SPRTs, that have been heated in an auxiliary furnace, are successively inserted into the cell well and calibrated. After all of the test SPRTs are calibrated, the preheated check SPRT is inserted again into the cell well and measurements made on it. This second reading should agree with the first to within ± 0.1 mK. See references [43,73,75].

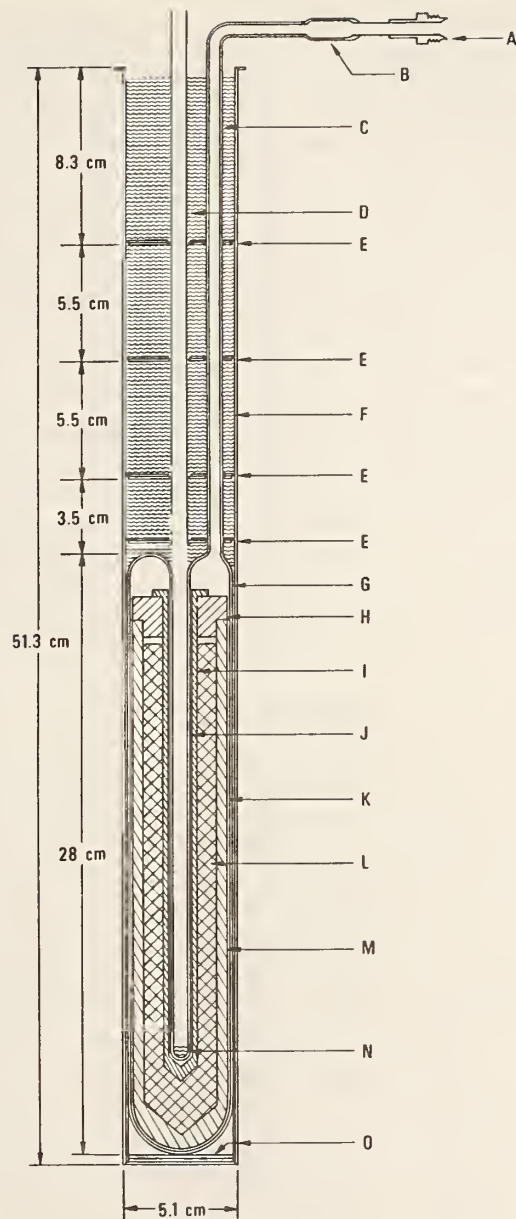

Figure 15. A graphite freezing point cell enclosed inside a fused silica tube with tube connection to high vacuum, purified argon gas source, and pressure gauge.

A -- connection to high vacuum, purified argon source, and pressure gauge, B -
 - fused-silica-to-Kovar graded seal, C -- fused-silica connecting tube, outer
 surface matte finished to minimize radiation piping, D -- thermometer guide
 tube, E -- heat shunts (Inconel disks), F -- thermal insulation (Fiberfrax), G -
 - fused-silica outer envelope, H -- graphite lid, I -- graphite thermometer
 well, J -- fused-silica thermometer well, K -- fused-silica fiber-woven tape for
 cushioning the graphite freezing-point cell inside the fused-silica enclosure,
 L -- metal sample, M -- graphite crucible, N -- fused-silica fiber pad for
 cushioning the thermometer, O -- Fiberfrax paper liner.

3.2.4.2.6 FREEZING POINT OF ALUMINUM

The freezing point of aluminum is assigned the value 933.473 K (660.323 °C). Metal samples of 99.9999% purity are commercially available. High purity graphite containers have been used successfully with aluminum. High purity liquid aluminum has been found to supercool about 1 °C to 2 °C; hence, its freeze can be initiated in the furnace without withdrawing the cell from the furnace. Aluminum is highly reactive, particularly at elevated temperatures; liquid aluminum is capable of dissolving many metals. Liquid aluminum reacts with moisture, forming the oxide and dissolving the hydrogen. The compounds Al_4C_3 and aluminum oxycarbide have been found in aluminum samples cast in graphite at 1000 °C. Because of the high chemical reactivity of aluminum, the graphite cell containing the metal must be completely protected by enclosing the cell in a fused silica envelope (see fig. 15). The argon or helium gas that is used to pressurize the freezing metal at one atmosphere must be thoroughly devoid of moisture, hydrogen, oxygen, hydrocarbons, and other substances that would react with liquid aluminum. The cell must not be heated more than 5 °C above the aluminum freezing point. [The first cryoscopic constant of aluminum is 0.00149/K. Consequently, the liquidus point of an ideal aluminum solution of 99.9999% purity would be approximately 0.7 mK lower than that of 100% pure aluminum.]

3.2.4.2.6.1 ASSEMBLY OF AN ALUMINUM-POINT CELL

High purity aluminum can be obtained in the form of shots or rods. Determine the internal volume of the graphite container, taking into account the thermometer well. Determine the mass of liquid aluminum required to fill the cell to within 0.5 cm of the graphite lid. Weight out aluminum shots or cut and clean aluminum rods that correspond to this mass. The rods should be cut with a carbide tipped tool and cleaned by etching in a hot (about 200 °C) solution consisting (by volume) of reagent grade phosphoric acid (15 parts), sulfuric acid (5 parts), and nitric acid (1 part), and then carefully rinsing many times in distilled water. Load the graphite crucible with the aluminum sample and then slide it into an extra-long fused-silica test tube such as that shown in figure 16. Insert the test tube into the tube furnace and evacuate it. While continuing to evacuate the tube, set the furnace temperature to control at about 5 °C above the melting point of aluminum. When the sample has completely melted, cool it to room temperature, while continuing to pump the tube. If aluminum shot, or rods of odd sizes, are used, the graphite cell will require several loadings and meltings before the desired amount of total sample has been loaded into the cell. When the graphite crucible is appropriately loaded with the sample, replace the silicone rubber stopper at the mouth of the extra-long test tube of figure 16 with the device for inserting the graphite thermometer well and lid (see reference [45] or fig. 17). Insert the test tube into the tube furnace, evacuate it, and then fill it with high purity argon to a pressure slightly above ambient. Melt the aluminum sample and push the graphite well and lid into the cell. Cool the sample to room temperature, while maintaining the argon pressure in the test tube slightly above the ambient pressure. Finally, assemble the graphite cell containing the aluminum sample into the desired freezing-point cell configuration (see references [43,45,70] or fig. 15).

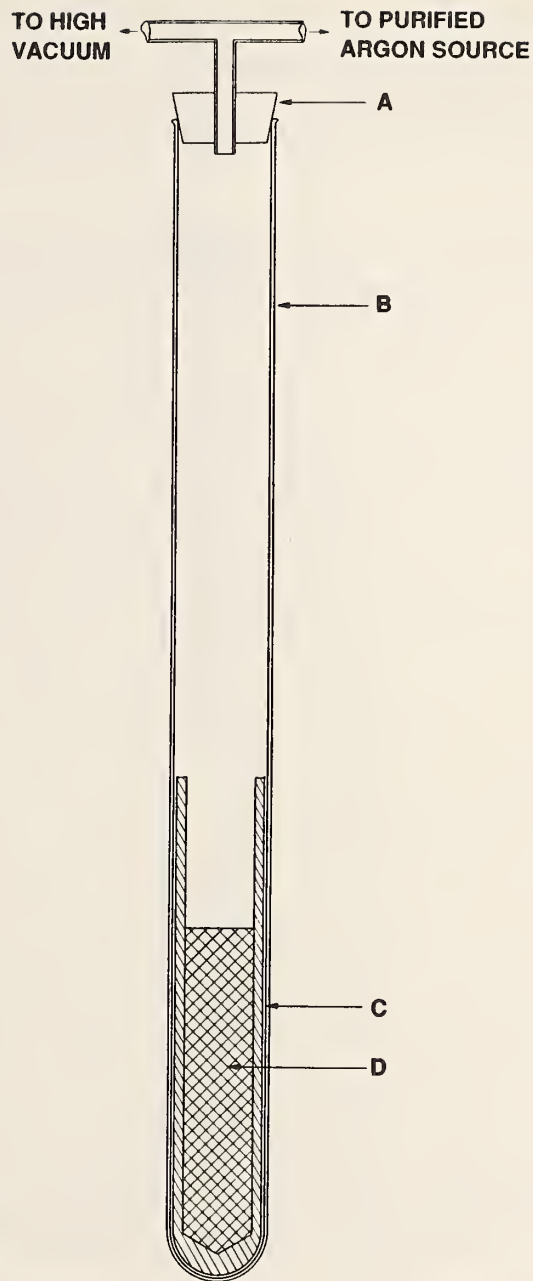

Figure 16. A method for filling a graphite freezing-point cell by melting the metal sample in the graphite crucible. The required amount of sample is placed in the graphite crucible and the crucible is inserted into the fused silica tube. To protect the sample, the fused silica tube is evacuated or filled with an inert gas (e.g., purified argon) before melting the metal in a tube furnace. Depending upon the geometry of the sample, the melting of two or more batches of sample may be required.

A -- Silicone rubber stopper, B -- fused silica tube, C -- graphite crucible, D -- metal sample.

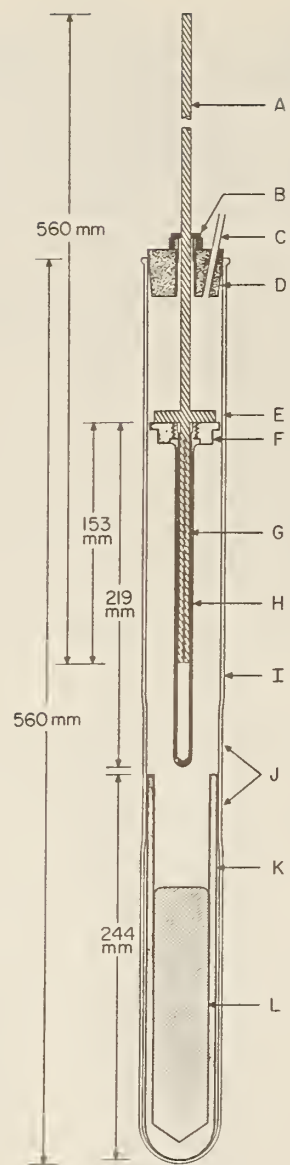

Figure 17. An apparatus for installing a graphite thermometer well and lid in a graphite crucible containing a molten metal sample.

A -- stainless steel pusher rod, B -- silicone rubber gas seal (permits linear motion of the pusher rod A), C -- inlet for purified argon gas that is used in purging and maintaining positive pressure of the gas during the assembly process, D -- silicone rubber stopper, E -- stainless steel flange attached to the pusher rod for pressing against the graphite lid and thermometer well during assembly, F -- graphite lid for the crucible, G -- slit on the pusher rod (the two halves spring outward to hold the graphite thermometer well and lid while melting the metal sample), H -- graphite thermometer well, I -- fused-silica tube, J -- a part of the fused-silica tube where its I.D. matches closely with the O.D. of the crucible and its lid so that the lid can be easily guided onto the opening of the crucible, K -- graphite crucible, L -- molten metal sample.

3.2.4.2.6.2 REALIZATION AND APPLICATION

SPRTs that are to be calibrated at the aluminum point and higher must have fused silica, sapphire, or ceramic insulation for the resistance element and its extension leads. Such high temperature SPRTs should be handled by procedures that avoid thermally shocking them.

A tube furnace containing the aluminum-point cell is controlled about 5 °C above the freezing point of aluminum until the metal is completely melted. It is convenient to control the furnace temperature automatically and melt the metal overnight so that the freezing of the metal can be started early in the morning and the calibration of two or three test SPRTs completed during the same day. Insert the aluminum-point check SPRT stepwise into the cell well. Since the SPRT will cool considerably between the time it is withdrawn from any auxiliary preheat furnace and inserted into the aluminum point cell, the SPRT is heated in the section of the thermometer guide tube that is maintained close to the furnace temperature. The SPRT is inserted initially to a location where its tip is about 3 cm above the graphite cell lid. After about 5 minutes, the SPRT is inserted an additional 5 cm and after another 5 minutes, another 5 cm, and so on until the tip of the SPRT is at the bottom of the thermometer well. When the SPRT indicates that the sample is about 5 °C above the freezing point, change the furnace temperature control settings to control at 5 °C below the freezing point in order to initiate rapid cooling for nucleation. When the check SPRT indicates recalescence, change the furnace temperature control settings to control at 1 °C to 0.5 °C below the freezing point. Withdraw the check SPRT stepwise from the cell, first to a location about 3 cm above the graphite cell lid. After about 5 minutes, withdraw the SPRT another 5 cm, and after another 5 minutes, another 5 cm, and so on until the SPRT is completely out of the thermometer guide tube. Next, insert successively into the cell well two fused silica glass rods, each initially at room temperature, for about 5 minutes each to freeze a thin mantle of solid aluminum around the thermometer well. Again insert the check SPRT stepwise, as described above, into the cell. Within 20 to 30 minutes, the readings on the check SPRT should indicate that the cell is at temperature equilibrium. After the readings on the check SPRT are completed, the SPRT is removed from the cell stepwise, as described above. The test SPRTs are then successively inserted stepwise, calibrated, and removed stepwise as described for the check SPRT. After all of the test SPRTs have been calibrated, the check SPRT is inserted again into the cell well and measurements made. This second reading at temperature equilibrium should agree with the first to within ± 0.1 mK.

When SPRTs are cooled rapidly from the aluminum point to ambient temperature, lattice vacancies are quenched in and these must be removed before the SPRTs are calibrated at the triple point of water. To relieve any quenched in lattice vacancies, the SPRTs that have been calibrated at the aluminum point should be heated in an auxiliary furnace at about 660 °C for about 30 minutes and then gradually cooled to about 500 °C over 3 hours or more before withdrawing from the furnace to cool at ambient temperature. See references [43,45,70].

3.2.4.2.7 FREEZING POINT OF SILVER

The freezing point of silver is assigned the value 1234.93 K (961.78 °C). Metal

samples of 99.9999% purity are commercially available in the form of pellets.

High purity graphite containers have been used successfully with silver. Liquid silver has been found to supercool not more than 0.5 °C; hence, its freeze can be initiated in the furnace without withdrawing the cell from the furnace. See references [3,15,72,98].

Oxygen is known to "dissolve" in liquid silver and lower the freezing point. Although the dissociation pressure of Ag_2O is expected to be quite high at the freezing point of silver, the lowering of the freezing point may be a combination of the solution of Ag_2O and of oxygen in liquid silver. (The dissociation pressure of Ag_2O is given as 414 atmospheres at 507 °C.) In a graphite environment at the freezing point of silver, a small amount of the oxygen will eventually react with the graphite; however, a newly prepared cell should be pumped at high vacuum at about 1000 °C for a week before back filling to one atmosphere with purified argon, nitrogen, or helium. [The first cryoscopic constant of silver is very small (0.000891/K). Consequently, the liquidus point of an ideal silver solution of 99.9999% purity would be approximately 1.1 mK lower than that of 100% pure silver.]

3.2.4.2.7.1 REALIZATION AND APPLICATION

The freezing-point cell of silver may be assembled by a procedure similar to that used with aluminum. See section 3.2.4.2.6.1.

SPRTs that are to be calibrated at the silver freezing point must have fused silica, sapphire, or ceramic insulation for the resistance coil and its extension leads. Such high temperature SPRTs should be handled by procedures that avoid thermally shocking them.

A tube furnace containing the silver freezing-point cell is controlled at about 5 °C above the freezing point until the metal is completely melted. (It is convenient to control the furnace temperature automatically and melt the metal overnight so that the freezing of the metal can be started early in the morning and the calibration of two or three test SPRTs completed during the same day.) Insert the silver-point check SPRT stepwise into the cell well. Since the SPRT will cool considerably between the time it is withdrawn from any auxiliary preheat furnace and inserted into the silver-point cell, the SPRT is heated in the section of the thermometer guide tube that is maintained close to the furnace temperature. The SPRT is inserted initially to a location where its tip is about 3 cm above the graphite cell lid. After about 5 minutes, the SPRT is inserted an additional 5 cm, and after another 5 minutes, another 5 cm, and so on until the tip of the SPRT is at the bottom of the thermometer well. When the SPRT indicates that the temperature of the sample is about 5 °C above the freezing point, change the furnace temperature control settings to control at 5 °C below the freezing point in order to initiate rapid cooling for nucleation. When the check SPRT indicates recalescence, change the furnace temperature control settings to control at 1 °C to 0.5 °C below the freezing point. Withdraw the check SPRT stepwise from the cell well, first to a location about 3 cm above the graphite cell lid. After about 5 minutes, withdraw the SPRT an additional 5 cm, and after another 5 minutes, another 5 cm, and so on until the SPRT is completely out of the thermometer guide tube. Next, insert successively into the cell well

two fused-silica glass rods, each initially at room temperature, for about 5 minutes each in order to freeze a thin mantle of solid silver around the thermometer well. Then, insert again the check SPRT stepwise, as described above, into the cell. Within about 20 to 30 minutes, the readings on the check SPRT should indicate that the cell is at temperature equilibrium. After the readings on the check SPRT are completed, it is removed from the cell stepwise, as described above. The test SPRTs are then successively inserted stepwise, calibrated, and removed stepwise as described for the check SPRT. After all of the test SPRTs have been calibrated, the check SPRT is inserted again into the cell well and read. This second reading should agree with the first to within ± 0.2 mK.

When SPRTs are cooled rapidly from the silver point to ambient temperature, lattice vacancies are quenched in and these must be removed before the SPRTs are measured at the triple point of water. To relieve any quenched in lattice vacancies, the SPRTs that have been calibrated at the silver point are heated in an auxiliary furnace at about 960 °C for 30 minutes or so and then gradually cooled to about 500 °C over 3.5 hours or more before withdrawing from the furnace to cool at ambient temperature. In order to protect the platinum of the SPRT from contamination by diffusion of metals at high temperatures (above 660 °C), the SPRTs should be enclosed in a platinum tube or other protective device.

3.2.5 CONTROL CHARTS OF CHECK THERMOMETERS

Control charts should be kept for all of the check thermometers associated with the various fixed points. Each of these charts will usually consist of a chronological graph of the check thermometer resistance value, $R(X)$, obtained from measurements in the fixed-point cell X , and of the ratio, $W(X) = R(X)/R(TPW)$, of the resistance value $R(X)$ to the resistance value, $R(TPW)$, obtained from measurements in a triple point of water cell. Presumably, such charts have been kept by those involved in precision thermometry. Entries on such control charts are made each time the particular fixed-point cell is used. Since those involved in precision thermometry would have used triple point of water cells for their work based on the IPTS-68 and they would have used $W(X)$, the same control chart can be continued with the ITS-90. The reason, of course, is that the behavior of the fixed-point cells is independent of the scale. Not all of the fixed points of the ITS-90, however, are the same as those of the IPTS-68. The ITS-90 uses some of the IPTS-68 fixed points but it also uses other fixed points. See reference [64].

Some metrologists may not have used $W(X)$ as defined above, but may have used the $W(t)$ of the IPTS-68. In that case, there will be a discontinuity in their control charts involving W when they implement the ITS-90 and begin using $W(X)$. The magnitude of the discontinuity will simply be the ratio $R(273.16 \text{ K})/R(273.15 \text{ K})$.

Control charts involving only $R(X)$ as a function of time will not have any discontinuity due to the change in the scale. Depending on the temperature of interest, of course, there may be need to start additional control charts.

3.3 RADIATION THERMOMETRY

Above the freezing point of silver (1234.93 K), the ITS-90 is defined in terms of Planck's radiation law. The values of temperatures T_{90} on the ITS-90 are obtained from the observed ratios of the spectral concentrations of the radiance L_λ of a blackbody at the wavelength (in vacuum) λ at T_{90} and at the reference temperature $T_{90}(X)$ according to eq. (31).

Inside a closed cavity, the radiation densities at different wavelengths λ depend only upon the temperature of the cavity walls. When a practical radiator is designed with a small hole in the wall to observe the radiation density at λ , there arises the question of how much the observed radiation departs from the blackbody radiation for a radiator design of a given geometry and material of construction. There are numerous papers on the theoretical analysis of the emissivities associated with cavity geometry and construction materials and descriptions of radiator designs that have been used in radiation thermometry [8,9,34,35,54,77,87,89,95]. The emissivities of cavities constructed of specular reflectors and diffuse reflectors have been analyzed [87]. It is expected that at high temperatures many materials become oxidized and, consequently, become diffuse reflectors. Although it is difficult to determine the actual temperature gradients in a cavity, the effect of temperature gradients has also been treated [10,11]. The effective emissivity of a graphite blackbody cavity has been computed to be 0.99997 ± 0.00003 [77].

For radiation thermometer calibrations at the silver, gold, or copper fixed point, the blackbody cavity should be constructed of graphite and surrounded by the freezing or melting metal contained in graphite to retain the high purity of the metal that is used. [The first cryoscopic constants of all three of these metals are extremely low (silver: 0.000891/K; gold: 0.000831/K; Cu: 0.000857/K). Consequently, the ideal-solution liquidus points of these metals of 99.9999% purity would be approximately 1.1 mK to 1.2 mK lower than that of 100% pure metals.]

References [27,55,56,57,62,77] give some details of construction of suitable graphite fixed-point blackbody cavities. The metal should be protected from air using an inert gas, such as argon, nitrogen, or helium, at a pressure slightly above ambient. The graphite container or auxiliary graphite scavengers can remove small amounts of oxygen impurities. For the blackbody cavity at the platinum point, pure alumina has been used in an oxidizing atmosphere to avoid the reaction between platinum metal and alumina in which oxygen gas is formed and metallic aluminum is dissolved in the platinum [33,86].

Usually, optical pyrometers or photoelectric pyrometers are used to determine the ratio of the radiances of a source of unknown temperature with that of the reference source. The optical system of the instrument is designed to focus a nearly monochromatic image of the radiation source onto a photodetector, which until about the mid-1950's was only the human eye; now the eye has been replaced in high precision measurements by photoelectric detectors because of their greater accuracy and their suitability for automation of the measurements. Two methods are commonly used to determine the ratios of spectral radiances. Either the photoelectric pyrometer is designed for comparing the two radiation sources by null-detection operation, similar in principle to the disappearing filament

optical pyrometers using suitable neutral filters or sectored discs for attenuating the radiation of one source, or for measuring directly the radiation density in terms of the detector output, e.g., photocell current. The latter requires high stability and linearity of signal processing [34,77]. The optics of the system may comprise refracting components (lenses) or reflecting components (mirrors) [28,34,54,57,87].

Equation (31) requires the ratio of monochromatic radiances. Usually, interference filters are used for this purpose. The bandwidth should be narrow with high transmittance while completely blocking out wavelengths outside the desired band. The temperature error is smaller the narrower the bandwidth. The temperature of the filters should be controlled, since they are sensitive to temperature changes. The photoelectric detector should be protected from undesired radiations from outside the solid angle defined by the aperture of the blackbody cavity. Where the output of the photocell is used to determine the ratio of the radiances, the linearity of the detector should be carefully checked or calibrated.

For details of optical pyrometer operation and attendant sources of errors, see references [28,34,54,57,77,87].

4. CALIBRATION OF THERMOMETERS ON THE ITS-90 AT VARIOUS LEVELS OF UNCERTAINTY AND SOME APPROXIMATIONS OF THE SCALE

In a standards laboratory, the design of apparatus and equipment for calibration of thermometers on the ITS-90 should be based on the desired accuracy, the number of thermometers and thermometric instruments that must be calibrated per year, the cost of realizing the ITS-90 (the fixed points and the measurement equipment), the cost of applying and maintaining the ITS-90, and the cost of research to maintain and make necessary improvements on the realization of the ITS-90. In a national standards laboratory, the efforts are directed toward the accurate realization of the ITS-90.

On 1 January 1990, no laboratory was able to calibrate thermometers over the complete range of the ITS-90 in accordance with the strict definition of the scale. Also, it is thought that on that date there was no immediate, wide-spread requirement for "experimental calibration conversion" from the IPTS-68(75) to ITS-90 over the complete range. Since the differences between IPTS-68(75) and ITS-90 were known, "arithmetical conversions" should have met most of the immediate requirements. Also, where stable thermometers have been used to maintain the EPT-76 or parts of the IPTS-68(75), the scales on those reference thermometers could be converted to ITS-90, using the published approximate differences between the scales, and then those thermometers can be used to calibrate other thermometers on the ITS-90. To realize the ITS-90 as defined and for international traceability, however, it is essential for the national calibration laboratory to have all of the fixed-point apparatus and measurement equipment. Furthermore, without continued research and comparison with other standards laboratories, the question regarding the accuracy of the realization of the scale will remain. The ITS-90 temperature calibrations are based on the thermal equilibrium states (vapor-liquid or liquid-solid equilibrium at known pressures, or vapor-liquid-solid triple points) of pure substances. Substances, however, have some impurity content; the amount must be small enough to have

negligible effect on the measurement of temperature. Obviously, the fixed-point device and the experimental procedure must be designed so that during calibration, the thermometer will be in thermal equilibrium with the equilibrium state of the defining fixed point. A method for checking whether or not the thermometer is in thermal equilibrium with a metal fixed-point standard device is to reduce the immersion in the device a known amount or vary the experimental conditions. The observed temperature change of the thermometer must correspond with the hydrostatic head effect of the liquid metal in the device, or there must be no observed temperature change with experimental conditions (such as changing furnace temperatures of metal fixed-point cells).

In order to determine the precision of the calibration process, it is essential to use check thermometers with every calibration. The results of the check thermometers will show whether the calibration process is "under statistical control" or not. The accumulated results show the precision of the "gross" calibration process.

Since some parts of this section deal with approximations of the ITS-90, and will make reference to the scale differences given in table 1, the methods by which the table was constructed will be described. The differences ($T_{90} - T_{76}$) between 5 K and 27 K were obtained using the same relation [99] as that used for ($T_{NPL-75} - T_{76}$), namely,

$$(T_{90} - T_{76})/\text{mK} = - 0.0056(T_{90}/\text{K})^2. \quad (40)$$

The differences ($T_{90} - T_{68}$) between 14 K and 100 K were obtained by Working Group 4 of the CCT by graphical interpolation of data from the published literature. The differences ($T_{90} - T_{68}$), or ($t_{90} - t_{68}$), between -200 °C and 630 °C were obtained by Working Group 4 of the CCT from published data on two SPRTs, one SPRT covering the range below 0 °C, and the other covering the range from 0 °C to 630 °C. A polynomial of the form:

$$(t_{90} - t_{68})/^{\circ}\text{C} = \sum_{i=1}^8 a_i (t_{90}/630)^i. \quad (41)$$

was fitted to the data from -200 °C to 630 °C and the coefficients are:

$$\begin{array}{ll} a_1 = -0.148759 & a_5 = -4.089591 \\ a_2 = -0.267408 & a_6 = -1.871251 \\ a_3 = 1.080760 & a_7 = 7.438081 \\ a_4 = 1.269056 & a_8 = -3.536296 \end{array}$$

The polynomial with these coefficients reproduce the tabulated differences [83] to within 1 mK above 0 °C and to within 1.5 mK below 0 °C. The differences ($t_{90} - t_{68}$) between 630 °C and 1064 °C were obtained by Working Group 4 by graphical interpolation from published data [14]. The differences ($t_{90} - t_{68}$) above 1064 °C were obtained from the equation:

$$(t_{90} - t_{68})/^{\circ}\text{C} = - 0.25 [(t_{90}/^{\circ}\text{C} + 273.15)/(1337.33)]^2. \quad (42)$$

In section 3, we discussed the direct realization of the ITS-90, using the

standard instruments of the scale, i.e., the realization of the scale at the lowest level of uncertainty. Of course, even the standard interpolating instruments used at the same thermodynamic temperature will indicate temperatures that differ slightly due to the devices having nonideal behavior and the scale being expressed in as simple a form as possible. The differences in indicated temperatures, however, are negligible for all practical purposes, being of the order of $\leq \pm 0.5$ mK for temperatures above about 5 K (i.e., assuming no errors in calibration). The realization of the ITS-90 in the liquid helium range of temperatures (0.65 K to 5.0 K) through helium vapor pressure-temperature relations can be accurate to about ± 0.1 mK or ± 0.2 mK.

For nonstandard types of thermometers used to approximate the ITS-90, the level of uncertainty is higher than the numbers just given because of the inherent instability of these thermometers. In all cases, these types of thermometers are calibrated by comparison with one or more standard instruments of the scale, e.g., vapor-pressure thermometry; vapor-pressure thermometry and gas thermometry; vapor-pressure thermometry, gas thermometry, and platinum resistance thermometry; gas thermometry and platinum resistance thermometry; platinum resistance thermometry; or pyrometers or spectral radiometers.

The NIST offers calibration services for various thermometers and pyrometers covering the range from 0.65 K to 4200 °C (see NIST SP 250). Of this range, the Chemical Process Metrology Division offers calibrations for contact thermometers covering the range from 0.65 K to 2400 K, and the Radiometric Physics Division offers calibrations for non-contact thermometers (radiation pyrometers) covering the range from 1234.93 K (961.78 °C) to 4200 °C. Calibrations of only contact-type thermometers will be discussed here. The types of contact thermometers calibrated include rhodium-iron resistance thermometers (RIRTs), germanium resistance thermometers (GRTs), standard platinum resistance thermometers (SPRTs), thermocouples (t/c), liquid-in-glass thermometers, thermistor thermometers, industrial platinum resistance thermometers (IPRTs), digital thermometers, and other special thermometers that are compatible with the NIST calibration equipment.

4.1 RHODIUM-IRON RESISTANCE THERMOMETERS

At temperatures below 13.8033 K, RIRTs and GRTs are, at the present time, the only thermometers that are suitable for precision temperature measurements. Also, RIRTs (and to a lesser extent GRTs) are suitable for use at temperatures up to the triple point of neon (24.5561 K). In the range from 0.65 K to about 25 K, RIRTs have reproducibilities of about ± 0.2 mK. Consequently, RIRTs don't degrade the realization of the ITS-90 significantly.

When the ITS-90 is realized, as defined, at NIST, some NIST RIRTs will be calibrated at many temperatures through the use of vapor-pressure thermometry and gas thermometry to produce reference-standard RIRTs, which will be periodically recalibrated. The resistance-temperature data of these RIRTs will be represented by a polynomial.

Customer RIRTs are calibrated by comparison with reference-standard RIRTs. A polynomial is fitted by the method of least squares to the RIRT resistance-temperature data so obtained and the results are reported in terms of the

polynomial that is selected.

Until the NIST completes the development of the CVGT and vapor-pressure thermometry apparatus with which the reference-standard RIRTs will be calibrated, calibrations of customer RIRTs are performed by comparison against reference-standard RIRTs that have been calibrated on the NPL-75 Scale [13] or on the EPT-76 and converted to the ITS-90.

To convert a calibration of an RIRT on the EPT-76 to an approximate calibration on the ITS-90, use the EPT-76 calibration resistance-temperature data, change the T_{76} values to T_{90} values using the $(T_{90} - T_{76})$ differences given in table 1, or calculated with eq (40), to produce a new set of resistance-temperature values, and then fit a polynomial of the required degree to these data. Using the coefficients of the polynomial so determined, produce the desired calibration table. A typical calibration report on the EPT-76 and one on the ITS-90 are given in appendix 3, sections 6.3.6 and 6.3.7, respectively.

4.2 GERMANIUM RESISTANCE THERMOMETERS

GRTs are comparable with, but not quite as stable as, RIRTs. They are calibrated in a manner similar to that of the RIRTs and their results similarly reported. At NIST, customer GRTs are calibrated by comparison with reference-standard RIRTs.

Anyone with a calibration on the EPT-76 may convert it to an approximate ITS-90 calibration by the same procedure as just outlined for RIRTs.

4.3 STANDARD PLATINUM RESISTANCE THERMOMETERS

Both capsule and long-stem type SPRTs are calibrated at the NIST. They will be discussed separately.

4.3.1 CAPSULE SPRTs (13.8033 K TO 429.7485 K OR 505.078 K)

For temperatures in the range from 13.8033 K to 273.16 K, capsule SPRTs are the most suitable thermometers. NIST has reference capsule SPRTs that have been, or will have been, calibrated at the defining fixed points in this range. Those SPRTs are used in calibrating customer thermometers by the comparison technique over the range from about 13 K to 84 K. The temperatures at which comparisons are made are at, or within a few mK of, the defining fixed-point temperatures of the ITS-90 and at temperatures approximately mid-way between the fixed-point values. Data at the temperatures intermediate to the fixed-point values are incorporated as a check on the calibration process. At and above the argon triple point (83.8058 K), customer capsule SPRTs are calibrated by the fixed-point method. See section 6.3 for an example of how to calculate the coefficients of the deviation functions.

4.3.2 LONG-STEM TYPE SPRTs (83.8058 K TO 1234.93 K)

Long-stem type SPRTs are used in the range from 83.8058 K to 1234.93 K. Two different long-stem type SPRTs are required to cover this whole range, one type being the customary SPRT having a nominal 25.5 Ω resistance at 0 °C and used in

the range from 83.8058 K to 692.677 K or to 933.473 K, and the second type having a somewhat longer stem and having a nominal 0.25 Ω or 2.5 Ω resistance and used in the range from 273.15 K to 1234.93 K. Such thermometers are very stable if handled carefully. In this range of temperature, SPRTs are calibrated by the fixed-point method, different sets of fixed points being required for different temperature subranges. The required fixed points for the different subranges were specified in section 2 of this document. In the fixed-point method, corrections for hydrostatic heads and gas pressures over the metals of the freezing-point and melting-point cells are made (see table 6). Similarly, corrections for hydrostatic heads present in metal and in gas triple-point cells are made. As a check on the accuracy of the calibration, measurements are made at one or more "redundant" defining fixed points lying within the temperature range of calibration or at a well characterized secondary fixed point, such as the cadmium freezing point, that lies within the temperature range of calibration. The value of the temperature of a check point calculated from the calibration constants should agree closely with the accepted value of that point. If not, then either an error was made in the calibration, one or more fixed-point cells are defective, or the thermometer is defective.

The procedures indicated in section 3.2 for realizing the various fixed-point temperatures and for handling SPRTs are followed carefully during calibration of platinum thermometers, especially so for calibration at the aluminum and silver freezing points (see sec. 3.2.4.2.7.1 for a discussion of lattice defects). See section 6.3 for an example of how the coefficients of the deviation functions are calculated from the data for the two sets of fixed points.

4.3.3 CONVERSION OF THE IPTS-68 CONSTANTS AND $W(T_{68})$ TABLES TO APPROXIMATE ITS-90 CONSTANTS AND $W(T_{90})$ TABLES

For SPRTs that have been calibrated recently on the IPTS-68(75), their calibrations may be converted to approximate calibrations on the ITS-90 at temperatures between the triple point of equilibrium hydrogen (13.8033 K) and the freezing point of zinc (692.677 K).

To make the conversion, first obtain values of $W(T_{68})$, i.e., $R(T_{68})/R(0\text{ }^{\circ}\text{C})$, from the IPTS-68(75) calibrations at values of T_{68} corresponding to the temperatures of the relevant fixed points of the ITS-90 in the appropriate range in which the conversion is desired. [Note: for a fixed point, the temperature values T_{68} and T_{90} are different, but the "hotness" is the same and so the resistance of a given SPRT remains unchanged. The temperature values on the two scales are defined to be the same only at the triple point of water and at the absolute zero of the temperature scales. Due to the nature of the scales, however, there are other temperature values of these scales that are also the same, which are fortuitous. See fig. 1, which shows the difference of t_{90} and t_{68} as a function of t_{90} .] Using these values of $W(T_{68})$ at the appropriate ITS-90 fixed-point temperatures, calculate values of $W(T_{90})$, i.e., $R(T_{90})/R(273.16\text{ K})$, by dividing the values of $W(T_{68})$ at the appropriate fixed-point temperatures by the value of $W(273.16\text{ K})$, i.e., the value of $W(T_{68})$ at the triple point of water. Table 8 shows samples of such conversions for a capsule-type SPRT and for a long-stem type SPRT calibrated on the IPTS-68(75). The calibration constants of the IPTS-68(75) equations for the two SPRTs are given also in table 8. The values of $W(T_{90})$ so

Table 8. Example of conversion of calibrations of SPRTs on the IPTS-68 to approximate calibrations on the ITS-90

Capsule SPRT, S/N 1812284 : e-H₂ TP to Sn FP

IPTS-68 CALIBRATION CONSTANTS

$R(0\text{ }^{\circ}\text{C}) = 25.4964808$	$\alpha = 3.9262754 \times 10^{-3}$	$\delta = 1.4964667$
$A_1 = -1.6314209 \times 10^{-4}$	$B_1 = -8.7377446 \times 10^{-7}$	$C_1 = -4.0321350 \times 10^{-7}$
$D_1 = 1.4525327 \times 10^{-8}$		
$A_2 = -2.1616630 \times 10^{-4}$	$B_2 = -1.7113512 \times 10^{-6}$	$C_2 = 6.6163769 \times 10^{-8}$
$D_2 = -2.2572375 \times 10^{-10}$		
$A_3 = -4.5449999 \times 10^{-4}$	$B_3 = 7.7242433 \times 10^{-6}$	$C_3 = -3.9028516 \times 10^{-8}$
$A_4 = 3.0860000 \times 10^{-7}$		$C_4 = -1.0880791 \times 10^{-4}$

ITS-90 CALIBRATION CONSTANTS CONVERTED FROM THE IPTS-68 CONSTANTS

$R(273.16) = 25.4974973$		
$a_1 = -2.5239001 \times 10^{-4}$	$b_1 = -1.2277862 \times 10^{-4}$	$C_1 = -2.3783015 \times 10^{-6}$
$a_9 = -2.5287142 \times 10^{-4}$	$b_9 = -1.1130131 \times 10^{-5}$	$C_2 = -4.3892024 \times 10^{-6}$
		$C_3 = -1.5608728 \times 10^{-6}$
		$C_4 = -2.1374663 \times 10^{-7}$
		$C_5 = -1.0344171 \times 10^{-8}$

Long-Stem SPRT, S/N RS8YA-5 : Ar TP to Zn FP

IPTS-68 CALIBRATION CONSTANTS

$R(0\text{ }^{\circ}\text{C}) = 25.5086208$	$A = 3.9856609 \times 10^{-3}$	$B = -5.8762238 \times 10^{-7}$
	$\alpha = 3.9268986 \times 10^{-3}$	$\delta = 1.49640322$
$A_4 = 2.6581418 \times 10^{-14}$		$C_4 = 9.3183900 \times 10^{-7}$

ITS-90 CALIBRATION CONSTANTS CONVERTED FROM THE IPTS-68 CONSTANTS

$R(273.16\text{ K}) = 25.5096386$	
$a_4 = -9.3225823 \times 10^{-5}$	$b_4 = -9.9914440 \times 10^{-6}$
$a_8 = -9.1058813 \times 10^{-5}$	$b_8 = -7.6061559 \times 10^{-6}$

obtained may then be used with the appropriate relations described in section 2 to obtain the constants of the ITS-90 deviation equations for the SPRTs. In table 8, we list the values of the deviation constants that were calculated from the sample data presented there. For comparison, values of the conversion from $W(T_{68})$ to $W(T_{90})$, as well as measured values of $W(T_{90})$, for the various relevant fixed-point temperatures T_{68} and T_{90} , respectively, are given in table 9. The deviations in the values of the last two columns of table 9 for the capsule SPRT reflect the inconsistency between the NBS-IPTS-68(75) wire scale and the difference between the IPTS-68(75) and the ITS-90 as given in table 1. Note that for the long-stem SPRT, the zero deviations for tin and zinc are a consequence of those fixed points having been used in both cases and the

Table 9. Values of $W(T_{68})$ and $W(T_{90})$ for various fixed-point temperatures T_{68} and T_{90} , respectively

<u>Capsule SPRT (S/N 1812284)</u>					
Fixed Point	T_{68}/K	$W(T_{68})$ meas.	T_{90}/K	$W(T_{90})$ calc.*	$W(T_{90})$ meas.
e-H ₂ TP	13.81	0.00119822**	13.8033	0.00119817	0.00119721
e-H ₂ BP	17.04200	0.00231120**	17.0357	0.00231111	0.00231049
e-H ₂ BP	20.280	0.00425962**	20.2711	0.00425945	0.00425815
Ne TP	24.5616	0.00848337**	24.5561	0.00848303	0.00848391
O ₂ TP	54.361	0.09182547**	54.3584	0.09182180	0.09182102
Ar TP	83.79723	0.21598575**	83.8058	0.21597714	0.21597795
Hg TP	234.3086	0.84421212**	234.3156	0.84417846	0.84417781
H ₂ O TP	273.16	1.00003987	273.16	1.00000000	1.00000000
Ga MP	302.9218	1.11815352**	302.9146	1.11810895	1.11810896
In FP	429.7848	1.60970773**	429.7485	1.60964355	1.60964566
Sn FP	505.1181	1.89263856	505.078	1.89256311	1.89256311
<u>Long-Stem SPRT (S/N RS8YA-5):</u>					
Ar TP	83.79723	0.21592943**	83.8058	0.21592084	0.21592281
Hg TP	234.3086	0.84418993**	234.3156	0.84415637	0.84415625
H ₂ O TP	273.16	1.00003976	273.16	1.00000000	1.00000000
Ga MP	302.9218	1.11817175***	302.9146	1.11812729	1.11812699
In FP	429.7848	1.60980450***	429.7485	1.60974050	1.60974062
Sn FP	505.1181	1.89278557	505.078	1.89271033	1.89271033
Zn FP	692.73	2.56885786	692.677	2.56875573	2.56875573

* Values of $W(T_{90})$ calc. were obtained by conversion of corresponding values of $W(T_{68})$ meas.

** These values were calculated from NBS-IPTS-68 calibration constants, based on the NBS wire scale and calibration at the triple point of water and the freezing point of tin (and the freezing point of zinc for the long-stem SPRT).

*** These values were calculated from IPTS-68 calibration constants determined from fixed points.

conversion process having been consistent. The deviations for the other fixed points (Ar, Hg, Ga, and In) reflect the non-uniqueness of this SPRT and possible errors incurred in measurements at those fixed points.

The results of tables 8 and 9 for the long-stem SPRT, with regard to the differences between temperatures determined from an actual ITS-90 calibration and those determined from an IPTS-68(75) calibration but then calculated for approximate ITS-90 values, are shown in figure 18. Note that at temperatures above 273.16 K, the zero deviation of figure 18 is a consequence of the fact that the same fixed points (tin and zinc) have been used in both cases and the conversion process having been consistent.

Difference Between ITS-90 Calibration and IPTS-68 Calibration
 Converted to ITS-90, Chino RS8YA-5, 25.5 ohm

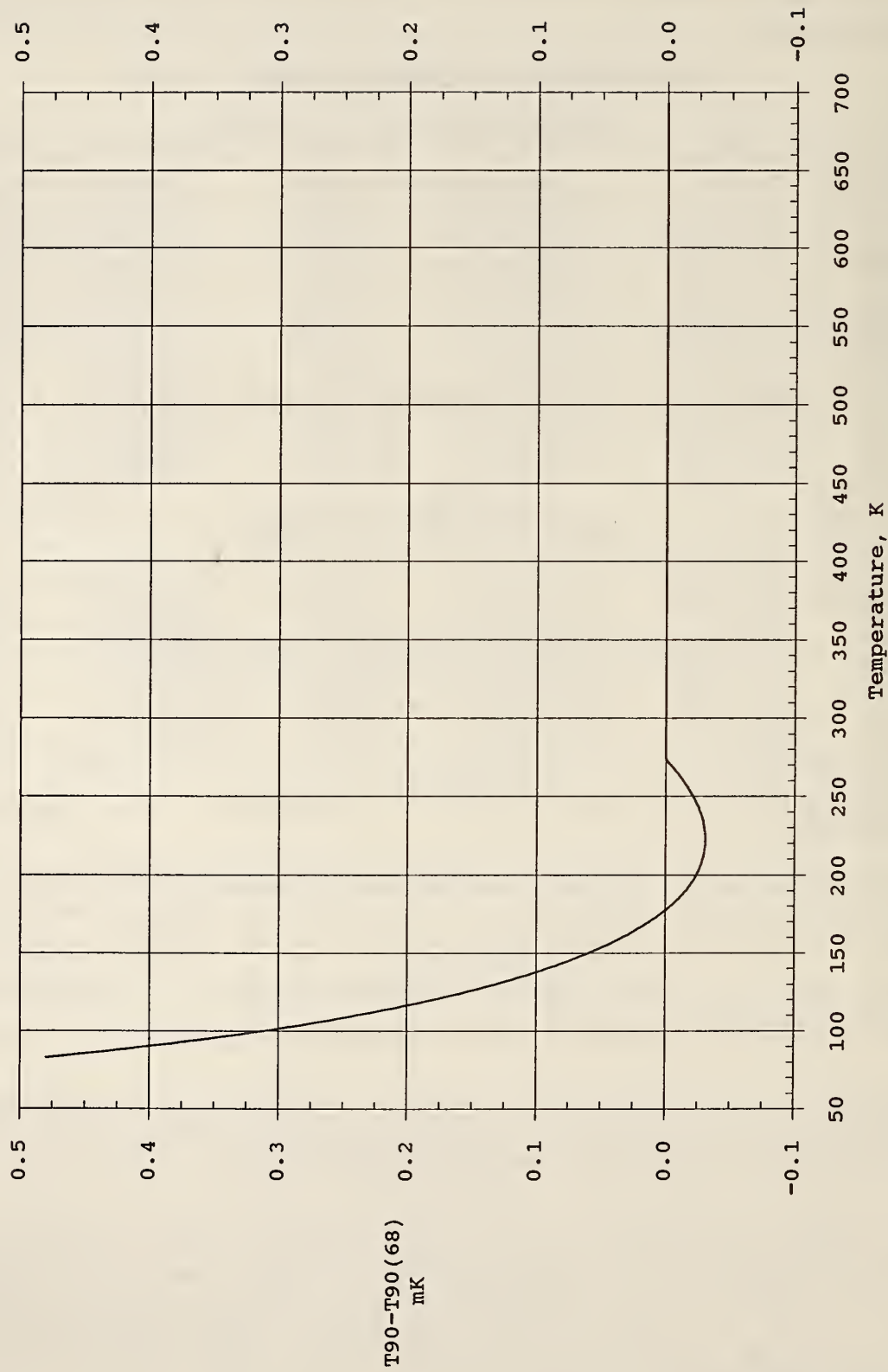

Figure 18. Differences between T_{90} and $(T_{90})_{as}$ as calculated from IPTS-68 calibration for the long-stem SPRT, S/N RS8YA-5, of table 8.

4.3.4 UNCERTAINTIES OF CALIBRATIONS AND THEIR PROPAGATION

Both systematic and random errors of measurements introduced in a calibration are propagated throughout the temperature range of the calibration. It is the total uncertainty arising from both of these types of errors, however, that is of interest to the customer and user of a calibrated thermometer. International comparisons of fixed-point cells below 90 K [79] and other data suggest that the uncertainties (at the 1σ level) in the realizations of the defining fixed points of the ITS-90 are about ± 0.2 mK for the triple points of hydrogen and neon, ± 0.1 mK for the triple point of oxygen through the melting point of gallium, ± 0.7 mK at the freezing point of indium, ± 1 mK from the freezing point of tin through the freezing point of aluminum, and ± 2 mK for the freezing point of silver.

The uncertainty of temperature measurements in the liquid helium range (0.65 K to 5.0 K) results from the uncertainty of the helium vapor-pressure measurements. The uncertainty (at the 1σ level) throughout this range of temperature is estimated to be approximately ± 0.1 mK to ± 0.2 mK.

For the CVGT, the uncertainty in the measured temperature over its temperature range (3.0 K to 24.5561 K) arises from uncertainties of realizations of the triple points of neon and of equilibrium hydrogen, of the measurement of the CVGT gas pressure, and of the measurement of the vapor pressure of helium. The uncertainty (at the 1σ level) throughout this range of temperature is estimated to be approximately ± 0.1 mK to ± 0.2 mK. Uncertainties introduced by a particular CVGT design may add to these uncertainties.

In the calibration of SPRTs over any given subrange, the possible error in the realization of each of the fixed points and any error of measurement must be considered and they will be propagated independently of that incurred at the other fixed points involved. The total uncertainty of measurements at a given temperature is then the root-mean-square of the appropriate contributing uncertainties. Curves showing the propagation of a \pm (unit error) incurred at each of the defining fixed points of the two major ranges are shown in figures 19 and 20. Figure 19 shows the propagation of errors associated with the fixed points below 273.16 K; and figure 20 shows curves for the fixed points used in the calibration of SPRTs in the range from 273.15 K to 1234.93 K. The labels on the various curves indicate the fixed-point in which there is the unit error in its temperature, and the other fixed points without error. As an example, consider the curve labelled Sn(Ag, Al, Zn) of figure 20. The symbol Sn indicates that the unit error occurs in the Sn freezing-point temperature; that is clearly indicated by a unit offset of the curve at that point. The symbols in parenthesis, i.e., (Ag, Al, Zn), indicate that the Ag, Al, and Zn freezing points were the other fixed points involved in the calibration and that measurements were made at those fixed-point temperatures without error. Also, it is assumed that the measurements at the triple point of water were without error. The other labelled curves are similarly interpreted. The straight lines labelled TPW show the errors propagated for an error of ± 0.1 mK made by the user in the triple point of water.

4.3.5 ESTIMATES OF POSSIBLE ERRORS INTRODUCED BY EXTRAPOLATIONS BEYOND THE RANGE OF CALIBRATION

It is unwise and is poor practice to use any thermometer beyond the temperature range over which it was calibrated. Nevertheless, some users persist in doing just that. In some cases, especially if the extrapolation is for only a few kelvins, the error introduced may be rather small. The errors of some typical extrapolations, calculated and depicted for NIST SPRTs, are shown in figures 21, 22, 23, 24, and 25.

The curve in figure 21 shows the error introduced for a NIST SPRT by extrapolating the deviation function, determined from calibration over the range from the triple point of argon to the triple point of water, downward from the argon triple point to 54 K. Extrapolating downward to about the boiling point of nitrogen (77 K) results in a fairly insignificant error in this case and, thus, can be done with the usual caution that some thermometers may not be as good as that of figure 21.

Figure 22 depicts the results for another NIST SPRT. The curve shows the error introduced by extrapolating the deviation function, determined from calibration over the range from the triple point of mercury to the melting point of gallium, downward from the mercury triple point to 84 K.

Figure 23 displays the results for the same NIST SPRT as used for figure 22, but the curve in this case shows the error introduced by extrapolating the deviation function, determined from calibration over the range from the triple point of mercury to the melting point of gallium, downward from the mercury triple point to only 200 K. A sizable error is shown for observations that would be made at Dry Ice temperatures (-78 °C).

Figure 24 depicts the results for several NIST SPRTs, but the curves in this case show the errors introduced by extrapolating their deviation functions, determined from calibration over the range from the triple point of water to the freezing point of zinc, downward from the triple point of water to -50 °C.

Figure 25 displays the results for several NIST SPRTs, but in this case the curves show the errors introduced by extrapolating their deviation functions, determined from calibration over the range from the triple point of water to the freezing point of zinc, upward from the freezing point of zinc to 934 K (660 °C).

As a general rule and good practice, one should never extrapolate any of the ITS-90 deviation functions beyond their range of application. If, however, the estimated uncertainty introduced by extrapolating a deviation function beyond the range of calibration is acceptable, then the user may do so, but with the knowledge that his particular thermometer may yield results with a larger uncertainty than that estimated. The user that makes such extrapolations should realize that not all SPRTs will behave as indicated in figures 21 through 25. The results depicted in these figures are examples only and are valid for only those SPRTs indicated. Other SPRTs may be better or worse.

ITS-90 Propagation of Calibration Errors
in Platinum Resistance Thermometry

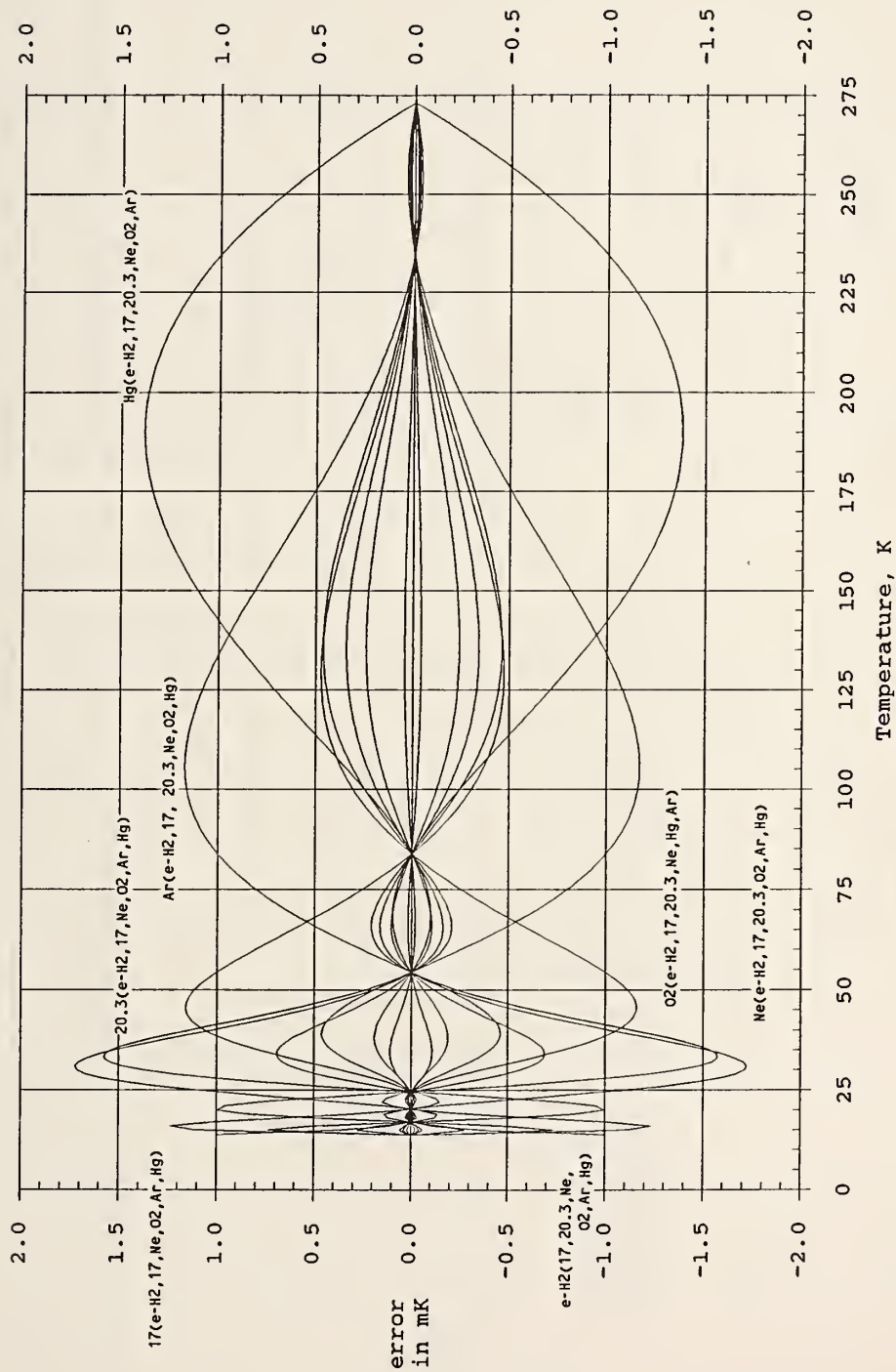

Figure 19. Propagation of errors from errors of calibration of SPRTs between 13.8033 K and 273.16 K. The curves show the error in the temperature values caused by a unit positive or unit negative error of calibration at each of the fixed points in the range, namely, the triple points of equilibrium hydrogen, neon, oxygen, argon, and mercury. The calibration at the triple point of water is assumed to have been made without error. The curves are identified by the fixed point with error outside the parenthesis and the fixed points without error inside the parenthesis.

ITS-90 Propagation of Calibration Errors
in Platinum Resistance Thermometry

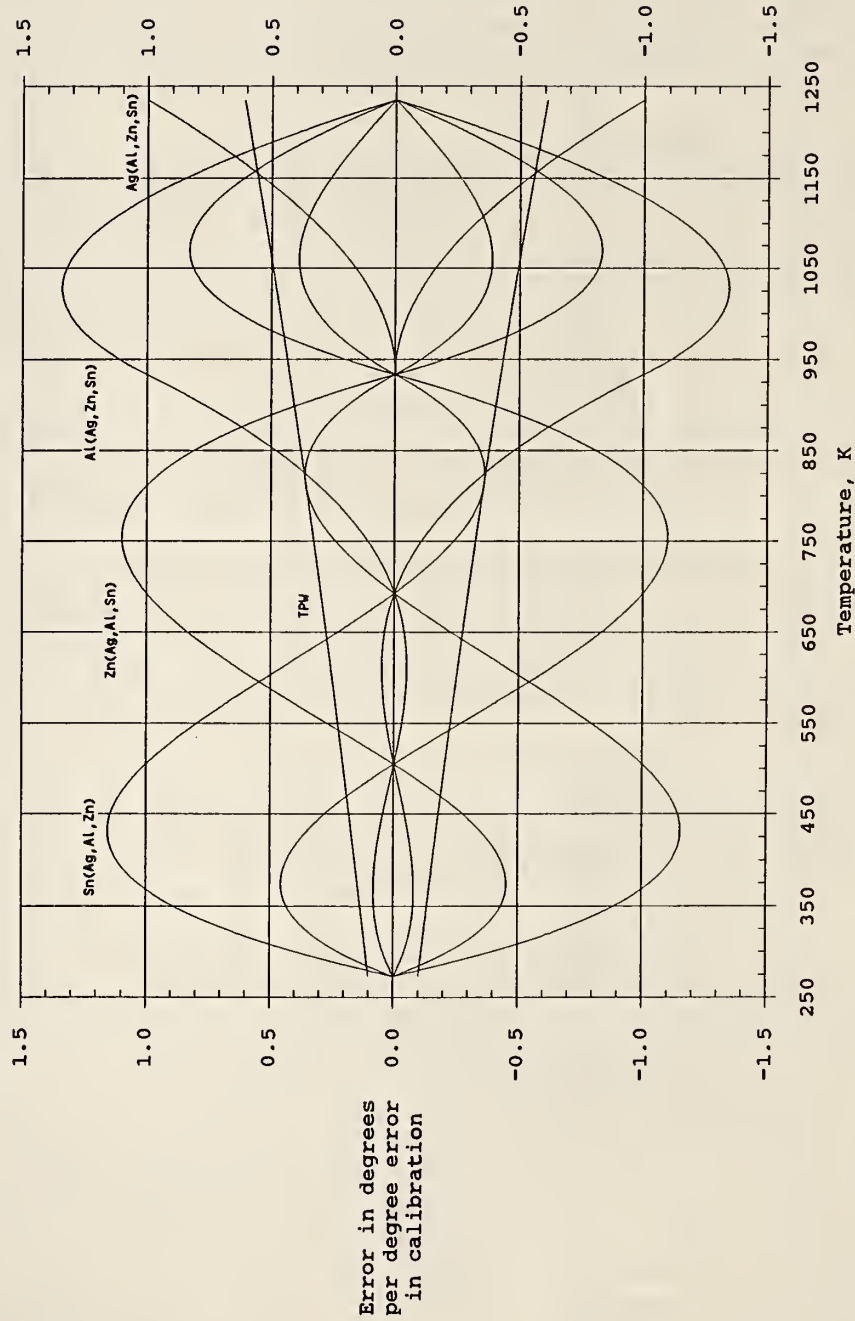

Figure 20. Propagation of errors from errors of calibration of SPRTs between 273.15 K and 1234.93 K. The curves show the error in the temperature values caused by a unit positive or unit negative error of calibration at each of the fixed points in the range, namely, gallium, indium, tin, zinc, aluminum, and silver points. The calibration at the triple point of water is assumed to have been made without error. The curves are identified by the fixed point with error outside the parenthesis and the three fixed points without error inside the parenthesis. Also included in this figure are error curves for errors made by the user at the triple point of water; these curves show propagation of ± 0.1 mK errors incurred at the triple point of water.

ITS-90, 25.5 ohm Capsule PRT 1812284
Oxygen Subrange - Extrapolated Argon Subrange

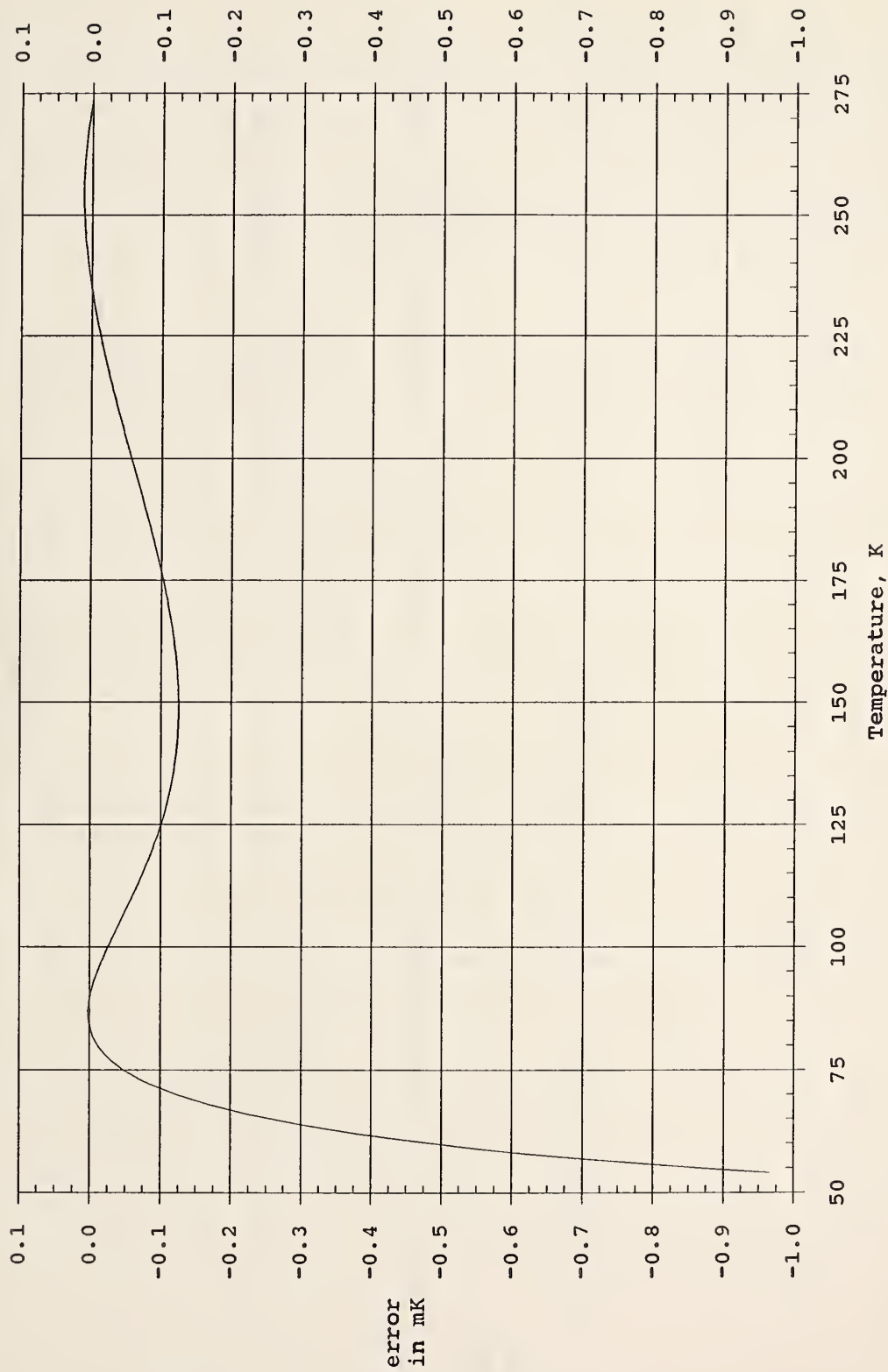

Figure 21. Error curve for a NIST SPRT; the curve shows the error introduced by extrapolating its deviation function, determined from calibration over the range from the triple point of argon to the triple point of water, downward from the triple point of argon to 54 K.

ITS-90, Chino Model R800-2, RS8YA-5, 25.5 ohm
Ar to T3 Subrange - Extrapolated Hg to Ga Subrange

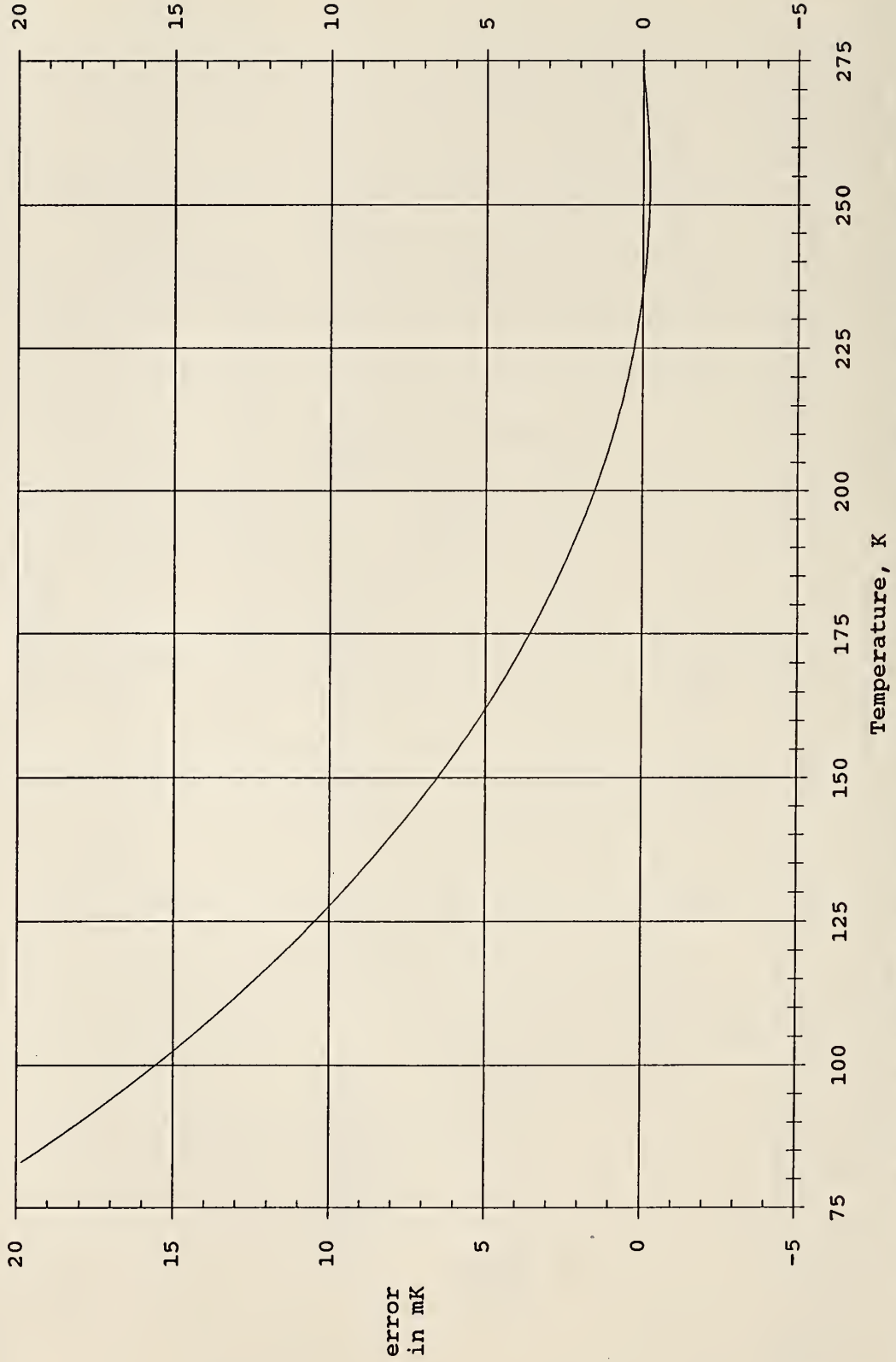

Figure 22. Curve for a NIST SPRT that shows the error introduced by extrapolating its deviation function, determined from calibration over the range from the triple point of mercury to the melting point of gallium, downward from the triple point of mercury to 84 K.

ITS-90, Chino Model R800-2, RS8YA-5, 25.5 ohm
Ar to T3 Subrange - Extrapolated Hg to Ga Subrange

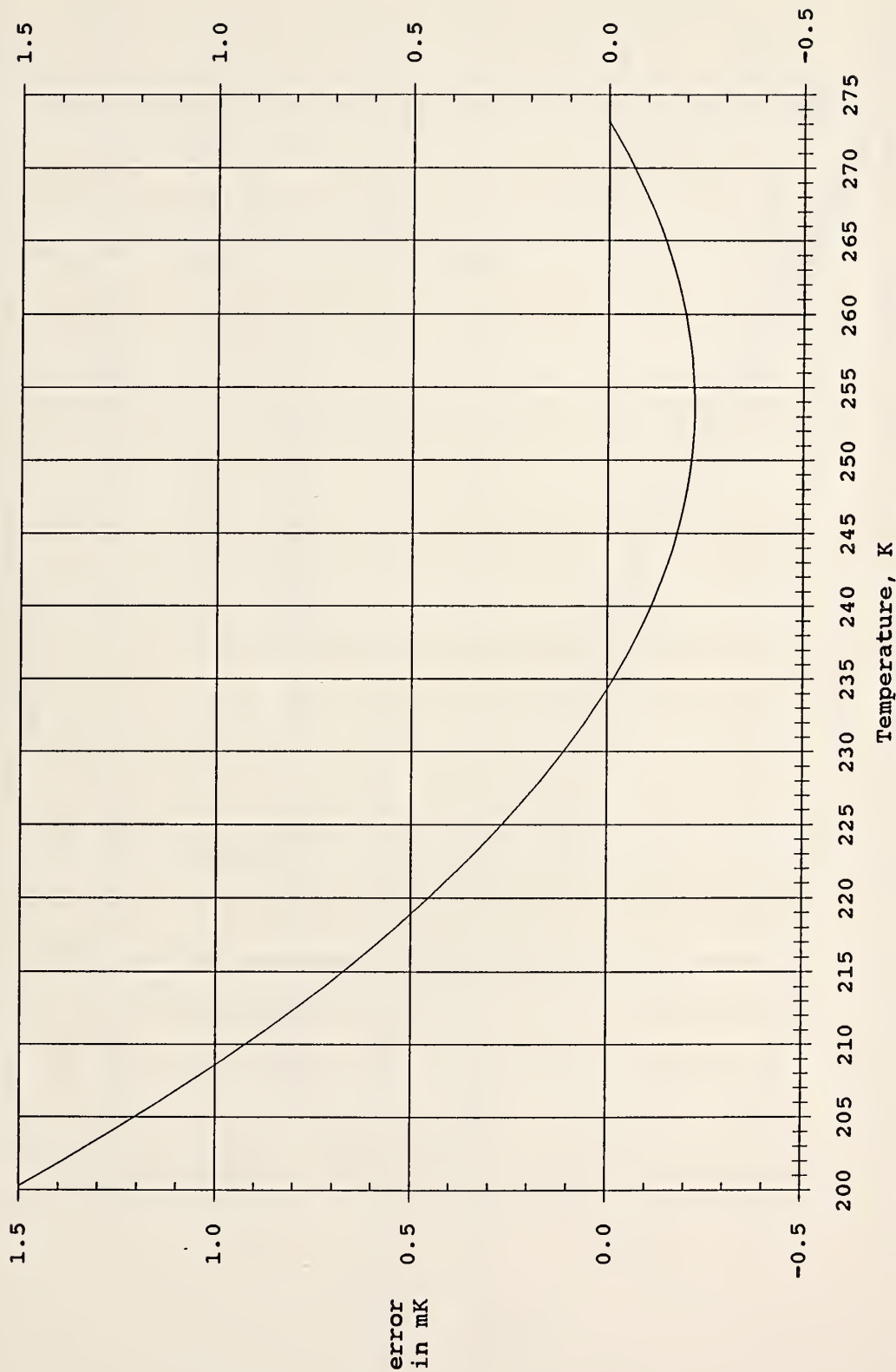

Figure 23. Curve for the NIST SPRT of figure 22 that shows the error introduced by extrapolating its deviation function, determined from calibration over the range from the triple point of mercury to the melting point of gallium, downward from the triple point of mercury to only 200 K.

ITS-90, 25.5 ohm PRTs
 Ar Subrange - Extrapolated Zn Subrange

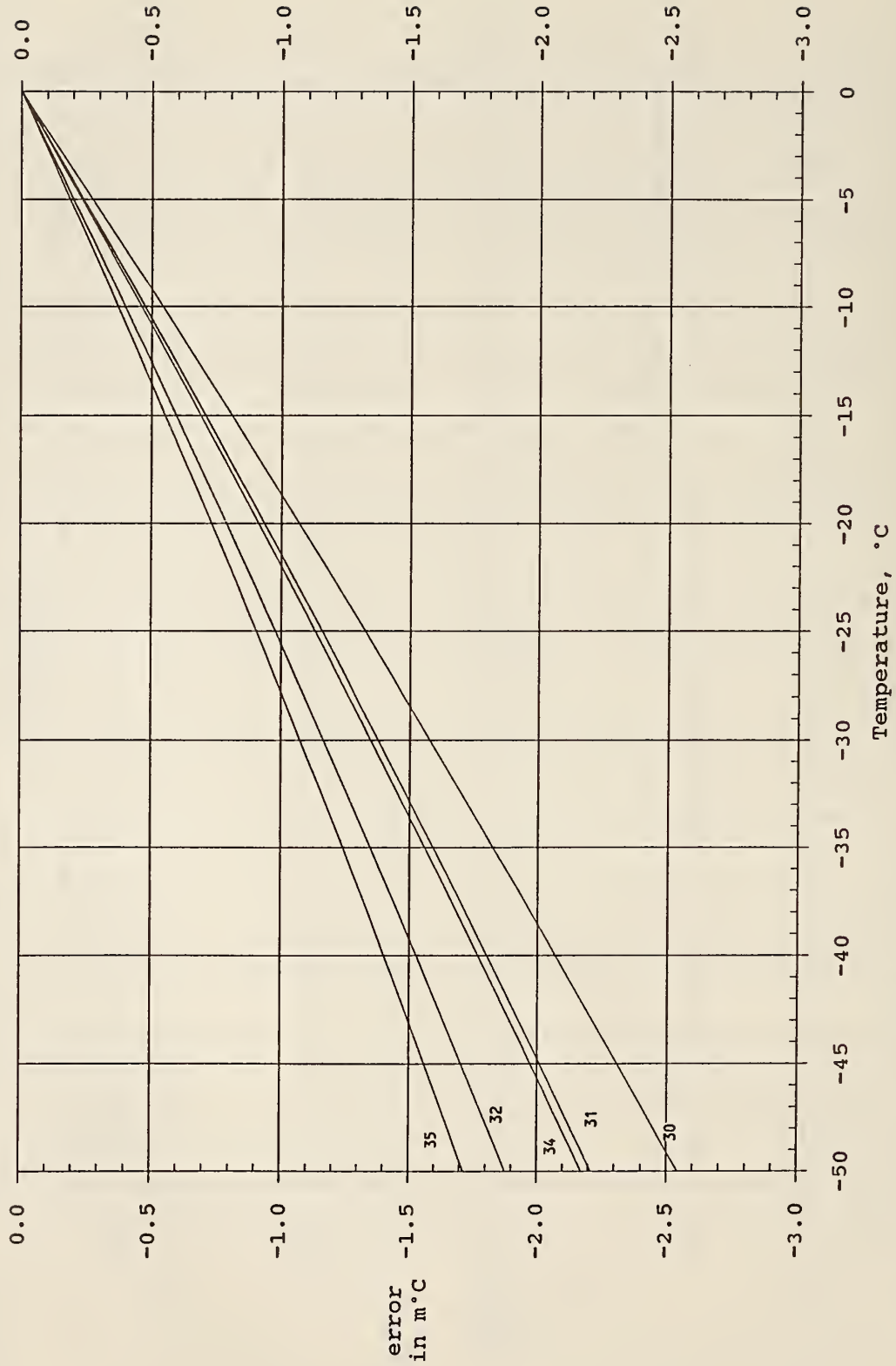

Figure 24. Curves for several NIST SPRTs that show the errors introduced by extrapolating their deviation functions, determined from calibration over the range from the triple point of water to the freezing point of zinc, downward from the triple point of water to -50 °C.

ITS-90, 25.5 ohm PRTs
Al Subrange - Extrapolated Zn Subrange

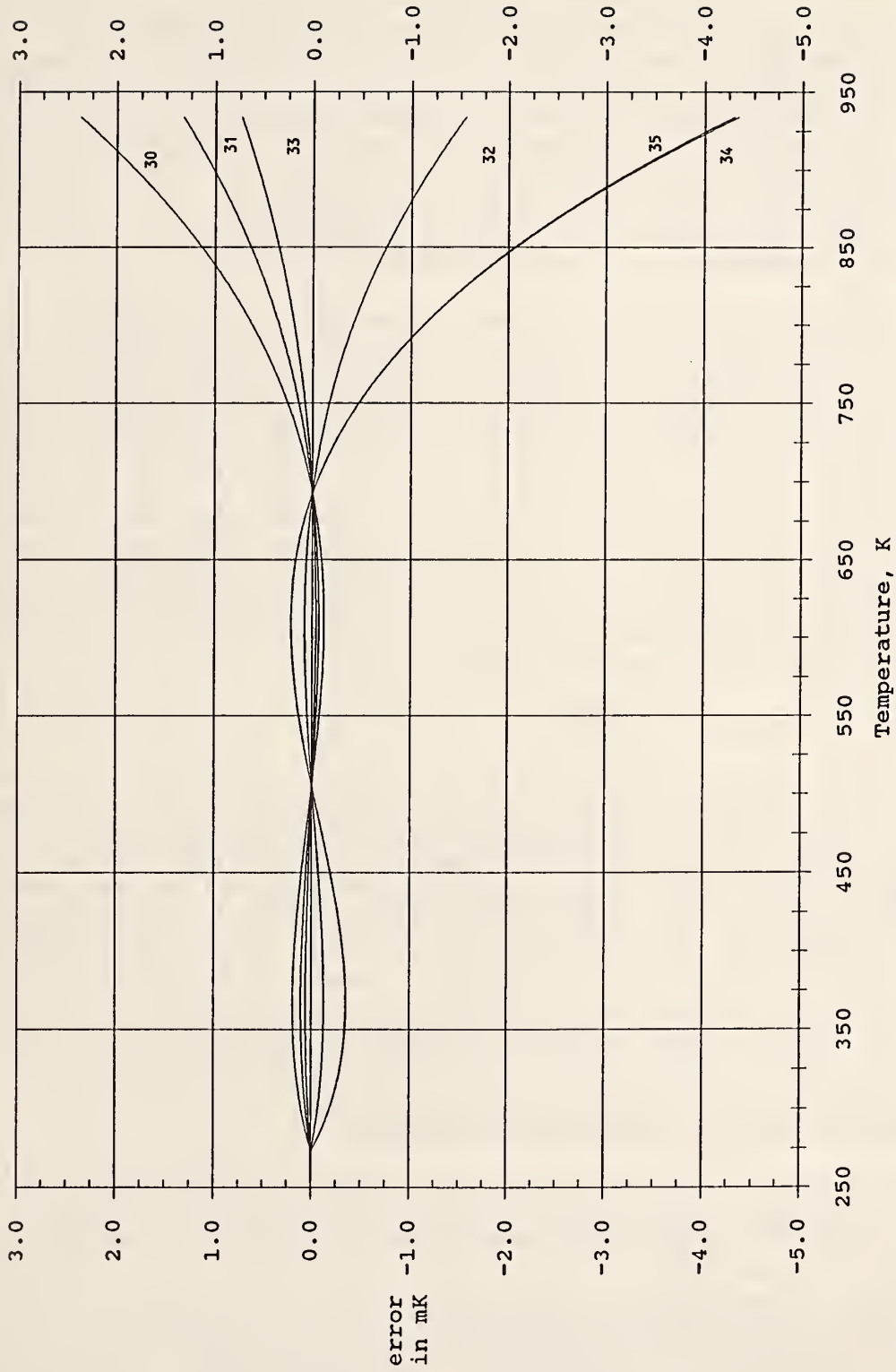

Figure 25. Curves for several NIST SPRTs that show the errors introduced by extrapolating their deviation functions, determined from calibration over the range from the triple point of water to the freezing point of zinc, upward from the freezing point of zinc to 934 K (660 °C). Also shown are subrange inconsistencies for the subrange triple point of water to zinc, relative to the subrange triple point of water to aluminum.

4.4 THERMOCOUPLES (77 K TO 2400 K)

There are numerous letter-designated types of thermocouples. The Type S thermocouple was the standard instrument of the IPTS-68(75) in the range from 630.74 °C to 1064.43 °C, but it is not a standard instrument of the ITS-90. Customer thermocouples are calibrated at NIST by using a set of temperature fixed points, by comparison with SPRTs, or by comparison with reference-standard thermocouples that have been calibrated either by comparison with an SPRT or a radiation pyrometer, or through the use of fixed points. For details of the calibration procedures and of the uncertainties involved, see NIST SP 250-35 [22] and NIST Monograph 175 [23] (or Monograph 125 [82]).

Usually, the calibration data for most types of thermocouples are analyzed relative to reference tables, such as those given in NBS Monograph 125 [82]. Monograph 125, of course, has reference tables for thermocouples based on the IPTS-68(75). This monograph has been revised and updated to give reference tables for all letter-designated thermocouples based on the ITS-90. The revised version of Monograph 125 is Monograph 175 [23] and it supersedes Monograph 125.

The electromotive-force-temperature data for a thermocouple calibrated on the IPTS-68(75) can be converted to an approximate ITS-90 calibration through the use of the differences ($t_{90} - t_{68}$) given in table 1 of this document and the S values in mV/°C for the relevant thermocouple given in Monograph 175 or Monograph 125. An example of this conversion is given in table 10. A typical calibration report is presented in appendix 3 (see sec. 6.3.8).

4.5 LIQUID-IN-GLASS THERMOMETERS

Liquid-in-glass thermometers have uncertainties of realization as small as ± 30 mK in the temperature range from 0 °C to about 100 °C, but deteriorates at lower and higher temperatures. Liquid-in-glass (primarily, mercury-in-glass) thermometers are calibrated at NIST by comparison with SPRTs in liquid baths of various kinds that cover different temperature ranges. For details of the calibration procedures and of the uncertainties involved, see NIST SP 250-23 [105]. An example of a calibration report, based on the IPTS-68(75), of a liquid-in-glass thermometer is given in appendix 3 (see sec. 6.3.9). A calibration report for the same thermometer, with the IPTS-68(75) calibration converted to an approximate ITS-90 calibration through the use of ($t_{90} - t_{68}$) differences given in table 1 is given also in appendix 3 (see sec. 6.3.10).

4.6 INDUSTRIAL PLATINUM RESISTANCE THERMOMETERS

Industrial platinum resistance thermometers (IPRTs) are designed primarily for use in the temperature range from about 77 K (approximate liquid nitrogen boiling point) to 500 °C. Typically, the manufacturer of IPRTs quotes minimum instabilities of the IPRTs at the ± 0.1 K level over this range of temperatures. Some IPRTs may be somewhat better than this but others may be considerably worse. As seen from table 1, the maximum difference of ($T_{90} - T_{68}$) below 500 °C is about 0.08 K, and therefore the difference in temperature due to the change in temperature scales is within the instability of many IPRTs. Continued use of the IPTS-68(75) and of equations and standards [American Society for Testing and Materials (ASTM) Standard, E 1137, and International Electrotechnical Commission

Table 10. Example of a conversion of calibration values of a type K thermocouple on the IPTS-68 to an approximate calibration on the ITS-90

Calibration Values on IPTS-68					Calibration Values on ITS-90	
t_{68} (°C)	emf_{68} (mV)	S (mV/°C) Monograph 125	$t_{90}-t_{68}$ (°C) Table 1	Δ [$=S \cdot (t_{90}-t_{68})$] (mV)	t_{90} (°C)	emf_{90}^a (mV)
0.0	0.000	0.0395	0.000	0.000	0.0	0.000
100.0	4.092	0.0414	-0.026	-0.001	100.0	4.093
200.0	8.130	0.0400	-0.040	-0.002	200.0	8.132
300.0	12.195	0.0415	-0.039	-0.002	300.0	12.197
400.0	16.383	0.0422	-0.048	-0.002	400.0	16.385
500.0	20.633	0.0426	-0.079	-0.003	500.0	20.636
600.0	24.904	0.0425	-0.115	-0.005	600.0	24.909
700.0	29.136	0.0419	0.20	0.008	700.0	29.128
800.0	33.288	0.0410	0.34	0.014	800.0	33.274
900.0	37.338	0.0400	-0.01	0.000	900.0	37.338
1000.0	41.281	0.0389	-0.19	-0.007	1000.0	41.288
1100.0	45.118	0.0378	-0.26	-0.010	1100.0	45.128

^a $emf_{90} = emf_{68} - \Delta$

(IEC) Standard, Publication 751] referenced to the IPTS-68(75), therefore, would result in an increase in uncertainty of temperature of only about 0.1 K if the temperature were expressed as being on the ITS-90. (Note: the ASTM and the IEC are converting their respective IPRT tables from the IPTS-68(75) to the ITS-90. ASTM Committee E-20 on Temperature Measurements is responsible for this conversion for the ASTM).

When IPRTs are calibrated on the ITS-90, of course, they may be calibrated in the same manner as is used for SPRTs. A better method of calibrating IPRTs, however, is to obtain resistance-temperature data by comparison with a calibrated SPRT at numerous temperatures over the range of interest and then fit a polynomial in t_{90} to $R(t_{90})$, to $R(t_{90})/R(0\text{ °C})$, or to $R(t_{90})/R(0.01\text{ °C})$ data by a least squares technique.

4.7 THERMISTOR THERMOMETERS, DIGITAL THERMOMETERS, AND OTHER TYPES OF THERMOMETERS

Thermistor thermometers, digital thermometers (with resistance, thermocouple, or diode sensors), and other types of thermometers are calibrated at NIST by comparison with SPRTs in liquid baths. The calibration procedures followed are similar to those used with liquid-in-glass thermometers. The uncertainties of calibration range from as small as ± 2 mK for thermistor thermometers to tenths

of kelvins for the others. The temperatures of calibration for these types of thermometers usually lie somewhere within the range from about 77 K to 850 K. Bead-in-glass probe type thermistors used in the moderate temperature range are quite stable and they may be used to approximate the ITS-90 at a level of about ± 1.5 mK to ± 2.0 mK [67]. In their case, a polynomial, the degree of which depends on the temperature range of the calibration, is fitted to resistance-temperature data and the results reported in terms of that polynomial. A calibration on the IPTS-68(75) may be converted to an approximate ITS-90 calibration by the same procedure as outlined for RIRTs.

4.8 THE LOGO OF THE NATIONAL CONFERENCE OF STANDARDS LABORATORIES FOR THE ITS-90

The National Conference of Standards Laboratories (NCSL) formed an Ad Hoc Committee on the Change of the Temperature Scale at the beginning of 1988 in order to publicize the new temperature scale (ITS-90) and to facilitate its implementation. At the NCSL meeting in July 1989, the Ad Hoc Committee adopted a logo, available from the NCSL [1800 30th Street, Suite 305B, Boulder, CO 80301, Tel. (303) 440-3339], that may be affixed to thermometers that have been calibrated on the ITS-90. The purpose of the logo, illustrated in figure 26, is to indicate at a glance, without having to refer to documentation, those thermometers in a laboratory that have been calibrated on the new scale. This is particularly useful for those laboratories that have their various thermometers calibrated on a prescribed schedule, with different thermometers being calibrated at different times.



Figure 26. The NCSL ITS-90 logo.

5. REFERENCES

- [1] Ancsin, J., Vapour Pressures and Triple Point of Neon and the Influence of Impurities on These Properties, *Metrologia* 14, 1-7 (1978).
- [2] Ancsin, J., Thermometric Fixed Points of Hydrogen, *Metrologia* 13, 79-86 (1977).
- [3] Ancsin, J., A Study of the Realization of the Melting and Freezing Points of Silver, *Metrologia* 26, 167-174 (1989).
- [4] Ancsin, J., Melting Curves and Heat of Fusion of Indium, *Metrologia* 21, 7-9 (1985).
- [5] Barber, C. R., Handley, R., and Herington, E. F. G., The Preparation and Use of Cells for the Realization of the Triple Point of Water, *Brit. J. Appl. Phys.* 5, 41-44 (1954).
- [6] Barber, C. R., A Proposal for a Practical Scale of Temperature Below 20 K, Temperature, Its Measurement and Control in Science and Industry, Edited by H. H. Plumb, Vol. 4, Part 1, pp. 99-103 (Instrument Society of America, Pittsburgh, 1972).
- [7] Barrick, P. L., Brown, L. F., Hutchinson, H. L., and Cruse, R. L., Improved Ferric Oxide Gel Catalysts for Ortho-Parahydrogen Conversion, Edited by K. D. Timmerhaus, Vol. 10, paper D-1, 131-189 (Plenum Press, New York, NY, 1965).
- [8] Bauer, G., and Bischoff, K., Evaluation of the Emissivity of a Cavity Source by Reflection Measurements, *Applied Optics* 10, 2639-2643 (1971).
- [9] Bedford, R. E., Effective Emissivities of Blackbody Cavities -- A Review, Temperature, Its Measurement and Control in Science and Industry, Edited by H. H. Plumb, Vol. 4, Part 1, pp. 425-434 (Instrument Society of America, Pittsburgh, PA, 1972).
- [10] Bedford, R. E. and Ma, C. K., Emissivities of Diffuse Cavities, II: Isothermal and Nonisothermal Cylindro-cones, *J. Opt. Soc. Am.* 65, 565-572 (1974).
- [11] Bedford, R. E. and Ma, C. K., Emissivities of Diffuse Cavities: Isothermal and Nonisothermal Cones and Cylinders, *J. Opt. Soc. Am.* 64, 339-349 (1974).
- [12] Belecki, N. B., Dziuba, R. F., Field, B. F., and Taylor, B. N., Guidelines for Implementing the New Representations of the Volt and Ohm Effective January 1, 1990, NIST Technical Note 1263 (June 1989).
- [13] Berry, K. H., NPL-75: A Low Temperature Gas Thermometry Scale from 2.6 K to 27.1 K, *Metrologia* 15, 89-115 (1979).
- [14] BIPM Com. Cons. Thermométrie, 17, 1989, in press.
- [15] Bongiovanni, G., Crovini, L., and Marcarino P., Effects of Dissolved Oxygen and Freezing Techniques on the Silver Point, *Metrologia* 11, 125-132 (1975).

- [16] Bonhoure, J. and Pello, R., Température du Point Triple du Gallium, *Metrologia* 19, 15-20 (1983).
- [17] Bonhoure, J. and Pello, R., Points Triples de l'Argon et du Méthane: Utilisation de Cellules Scellées, *Metrologia* 16, 95-99 (1980).
- [18] Bonhoure, J. and Pello, R., Temperature of the Triple Point of Methane, *Metrologia* 14, 175-177 (1978).
- [19] Bonhoure, J. and Terrien, J., The New Manobarometer of the Bureau International des Poids et Mesures, *Metrologia* 4, 59-68 (1968).
- [20] Bonnier, G. and Hermier, Y., Thermal behavior of thermometric sealed cells and of a multi-compartment cell, Temperature, Its Measurement and Control in Science and Industry, Edited by J. F. Schooley, Vol. 5, Part 1, pp. 231-237 (American Institute of Physics, New York, 1982).
- [21] Bonnier, G. and Moser, A., Development at the Institut National de Métrologie of sealed cells as IPTS fixed points, *Measurement (IMEKO)* 1, 143-151 (1983).
- [22] Burns, G. W. and Scroger, M. G., The Calibration of Thermocouples and Thermocouple Materials, NIST Special Publication 250-35 (April 1989).
- [23] Burns, G. W. and Scroger, M. G., Temperature-electromotive Force Reference Functions and Tables for Letter-designated Thermocouple Types Based on the ITS-90, NIST Monograph 175 (1990).
- [24] Cataland, G., Edlow, M. H., and Plumb, H. H., Recent Experiments on Liquid Helium Vapor Pressure Measurements from 2 °K to 4 °K, Temperature, Its Measurement and Control in Science and Industry, Edited by F. G. Brickwedde, Vol. 3, Part 1, pp. 413-417 (Reinhold Publishing Corporation, New York, 1962).
- [25] Chappuis, P., Études sur le Thermomètre a Gaz et Comparison des Thermomètres a Mercure avec le Thermomètre a Gaz, *Trav. et Mém. BIPM* 6, 1-125 plus 187 pages of observations (1888).
- [26] Chattle, M. V., Rusby, R. L., Bonnier, G., Moser, A., Renaot, E., Marcarino, P., Bongiovanni, G., and Frassinetti, G., An intercomparison of gallium fixed point cells, Temperature, Its Measurement and Control in Science and Industry, Edited by J. F. Schooley, Vol. 5, Part 1, pp. 311-316 (American Institute of Physics, New York, 1982).
- [27] Coates, P. B. and Andrews, J. W., A precise determination of the freezing point of copper, *J. Phys. F: Metal Phys.*, 8, 277-285 (1978).
- [28] Coates, P. B., The NPL photon-counting pyrometer, Temperature Measurement, 1975, The Institute of Physics Conference Series Number 26, Edited by B. F. Billing and T. J. Quinn, Chapter 5, pp. 238-243 (The Institute of Physics, London, 1975).

- [29] Comptes Rendus des Séances de la Dix-huitième Conférence Générale des Poids et Mesures, Resolution 7, p. 101 (1987).
- [30] Comptes Rendus des Séances de la Dixième Conférence Générale des Poids et Mesures, Resolution 3, p. 79 (1954).
- [31] Compton, J. P., The Realization of Low Temperature Fixed Points, Temperature, Its Measurement and Control in Science and Industry, Edited by H. H. Plumb, Vol. 4, Part 1, pp. 195-209 (Instrument Society of America, Pittsburgh, PA, 1972).
- [32] Compton, J. P. and Ward, S. D., Realization of the Boiling and Triple Points of Oxygen, *Metrologia* 12, 101-113 (1976).
- [33] Darling, A. S. and Selman, G. L., Some Effects of Environment on the Performance of Noble Metal Thermometers, Temperature, Its Measurement and Control in Science and Industry, Edited by H. H. Plumb, Vol. 4, Part 3, pp. 1633-1644 (Instrument Society of America, Pittsburgh, PA, 1972).
- [34] DeWitt, D. P. and Nutter, G. D., Theory and Practice of Radiation Thermometry (John Wiley and Sons, Inc., New York, NY, 1988).
- [35] DeWitt, D. P. and Hernicz, R. S., Theory and Measurement of Emittance Properties for Radiation Thermometry Applications, Temperature, Its Measurement and Control in Science and Industry, Edited by H. H. Plumb, Vol. 4, Part 1, pp. 459-482 (Instrument Society of America, Pittsburgh, PA, 1972).
- [36] Ditmars, D. A. and G. T. Furukawa, Detection and Damping of Thermal-acoustic Oscillations in Low-temperature Measurements, *J. Res. Natl. Bur. Stands.* 69C, 35-38 (1965).
- [37] Durieux, M. and Rusby, R. L., Helium Vapour Pressure Equations on the EPT-76, *Metrologia* 19, 67-72, (1983).
- [38] Durieux, M., van Dijk, J. E., ter Harmsel, H., Rem, P. C., and Rusby, R. L., Helium Vapor Pressure Equations on the EPT-76, Temperature, Its Measurement and Control in Science and Industry, Edited by J. F. Schooley, Vol. 5, Part 1, pp. 145-154 (American Institute of Physics, New York, 1982).
- [39] Elliott, R. P., Constitution of Binary Alloys, First Supplement (McGraw-Hill Book Company, New York, NY, 1965).
- [40] Ferguson, J. A., Realization of the Triple Point of Water, *J. Phys. E: Sci. Instrum.* 3, 447-451 (1970).
- [41] Furukawa, G. T., Reproducibility of the Triple Point of Argon in Sealed Transportable Cells, Temperature, Its Measurement and Control in Science and Industry, Edited by J. F. Schooley, Vol. 5, Part 1, pp. 239-248 (American Institute of Physics, New York, NY, 1982).

[42] Furukawa, G. T., Bigge, W. R., and Riddle, J. L., Triple Point of Argon, Temperature, Its Measurement and Control in Science and Industry, Edited by H. H. Plumb, Vol. 4, Part 1, pp. 231-243 (Instrument Society of America, Pittsburgh, PA, 1972).

[43] Furukawa, G. T., Riddle, J. L., Bigge, W. R., and Pfeiffer, E. R., Application of Some Metal SRM's as Thermometric Fixed Points, NBS Special Publication 260-77, 140 pages, August 1982.

[44] Furukawa, G. T., Piccirelli, J. H., Reilly, M. L., Cryoscopic Determination of the Purity of Benzene by Calorimetry, Purity Determinations by the Thermal Methods, Edited by R. L. Blaine and C. K. Schoff, pp. 90-106 (American Society for Testing and Materials, Philadelphia, PA, 1984).

[45] Furukawa, G. T., Investigation of Freezing Temperatures of National Bureau of Standards Aluminum Standards, J. Res. Natl. Bur. Stand. (U.S.) 78A, 477-495 (1974).

[46] Furukawa, G. T., Riddle, R. L., and Bigge, W. R., Investigation of freezing temperatures of National Bureau of Standards tin standards, Temperature, Its Measurement and Control in Science and Industry, Edited by H. H. Plumb, Vol. 4, Part 1, pp. 247-263 (Instrument Society of America, Pittsburgh, PA, 1972).

[47] Furukawa, G. T., The Triple Point of Oxygen in Sealed Transportable Cells, J. Res. Natl. Bur. Stands. (U.S.) 91, 255-275 (1986).

[48] Gordon, C. L. and Wichers, E., Purification of Mercury and Its Physical Properties, Ann. New York Acad. Sci. 65, 369-387 (1957).

[49] Guildner, L. A. and Edsinger, R. E., Deviation of International Practical Temperatures from Thermodynamic Temperatures in the Temperature Range from 273.16 K to 730 K, J. Res. Bur. Stands. 80A, 703-738 (1976).

[50] Guildner, L. A., Stimson, H. F., Edsinger, R. E., and Anderson, R. L., An Accurate Mercury Manometer for NBS Gas Thermometer, Metrologia 6, 1-18 (1970).

[51] Hansen, M., Constitution of Binary Alloys (McGraw-Hill Book Company, Inc., New York, NY, 1958).

[52] Harrison, E. R., Hatt, D. J., Prowse, D. B., and Wilbur-Ham, J., A New Interferometric Manometer, Metrologia 12, 115-122 (1976).

[53] Jangg, G. and Palman, H., Die Löslichkeit verschiedener Metalle in Quecksilber, Zeit. Metallkde. 54, 364-369 (1963).

[54] Jones, T. P. and Tapping, J., A photoelectric pyrometer temperature scale below 1064.43 °C and its use to measure the silver point, Temperature, Its Measurement and Control in Science and Industry, Edited by J. F. Schooley, Vol. 5, Part 1, pp. 169-174 (American Institute of Physics, New York, 1982).

- [55] Jones, T. P. and Tapping, J., The Determination of the Thermodynamic Temperatures of Thermometry Fixed Points in the Range 660 °C to 1064 °C, *Metrologia* 25, 41-47 (1988).
- [56] Jung, J. J., Determination of the difference between the thermodynamic fixed-point temperatures of gold and silver by radiation thermometry, Temperature Measurement, 1975, The Institute of Physics Conference Series Number 26, Edited by B. F. Billing and T. J. Quinn, Chapter 5, pp. 278-286 (The Institute of Physics, London, 1975).
- [57] Jung, H. J., A Measurement of Thermodynamic Temperatures Between 683 K and 933 K by an Infrared Pyrometer, *Metrologia* 23, 19-31 (1986).
- [58] Kemp, R. C. and Kemp, W. R. G., The Triple Point, Boiling Point and 17 K Point of Equilibrium Hydrogen, *Metrologia* 15, 155-159 (1979).
- [59] Kemp, R. C., Kemp, W. R. G., and Cowan, J. A., The Boiling Points and Triple Points of Oxygen and Argon, *Metrologia* 12, 93-100 (1976).
- [60] Kemp, R. C., Kemp, W. R. G., and Besley, L. M., A Determination of Thermodynamic Temperatures and Measurements of the Second Virial Coefficient of ⁴He Between 13.81 K and 287 K Using a Constant-Volume Gas Thermometer, *Metrologia* 23, 61-86 (1986/87)
- [61] Klein, H. -H., Klempt, G., and Storm, L., Measurement of the Thermodynamic Temperature of ⁴He at Various Vapour Pressures by a Noise Thermometer, *Metrologia* 15, 143-154 (1979).
- [62] Lee, R. D., Construction and Operation of a Simple High-Precision Copper-Point Blackbody and Furnace, NBS Technical Note 483, May 1969.
- [63] Maghenzani, R., Molinar, G. F., Marzola, L., and Kulshrestha, R. K., Pressure Metrology up to 5 MPa in Different Gas Media, *J. Phys. E: Sci. Instrum.* 20, 1173-1179 (1987).
- [64] Mangum, B. W., Platinum Resistance Thermometer Calibrations, NBS Special Publication 250-22 (October 1987).
- [65] Mangum, B. W., Triple point of gallium as a temperature fixed point, Temperature, Its Measurement and Control in Science and Industry, Edited by J. F. Schooley, Vol. 5, Part 1, pp. 299-309 (American Institute of Physics, New York, 1982).
- [66] Mangum, B. W., Special Report on the International Temperature Scale of 1990; Report on the 17th Session of the Consultative Committee on Thermometry, *J. Res. Natl. Inst. Stand. Technol.* 95, 69-77 (1990).
- [67] Mangum, B. W., Triple point of succinonitrile and its use in the calibration of thermistor thermometers, *Rev. Sci. Instrum.* 54, 1687-1692 (1983).
- [68] Mangum, B. W. and Thornton, D. D., Determination of the Triple-Point Temperature of Gallium, *Metrologia* 15, 201-215 (1979).

[69] Mangum, B. W. Determination of the Indium Freezing-point and Triple-point Temperatures, *Metrologia* 26, 211-217 (1989).

[70] McAllan, J. V. and Ammar, M. M., Comparison of the freezing points of aluminum and antimony, Temperature, Its Measurement and Control in Science and Industry, Edited by H. H. Plumb, Vol. 4, Part 1, pp. 273-285 (Instrument Society of America, Pittsburgh, PA, 1972).

[71] McConville, G. T., The Effect of the Measuring Tube Surface on Thermomolecular Pressure Corrections in Vapor Pressure Thermometry, Temperature, Its Measurement and Control in Science and Industry, Edited by H. H. Plumb, Vol. 4, Part 1, pp. 159-165 (Instrument Society of America, Pittsburgh, PA, 1972).

[72] McLachlan, A. D., Uchiyama, H., Saino, T., and Nakaya, S., The Stability of the Freezing Point of Copper as a Temperature Standard, Temperature, Its Measurement and Control in Science and Industry, Edited by H. H. Plumb, Vol. 4, Part 1, pp. 287-293 (Instrument Society of America, Pittsburgh, PA, 1972).

[73] McLaren, E. H., The Freezing Points of High Purity Metals as Precision Temperature Standards. II. An Investigation of the Freezing Temperatures of Zinc, Cadmium, and Tin, *Can. J. Phys.* 35, 1086-1106 (1957).

[74] McLaren, E. H., The Freezing Points of High Purity Metals as Precision Temperature Standards. IV. Indium: Thermal Analyses on Three Grades of Cadmium, *Can. J. Phys.* 36, 1131-1147 (1958).

[75] McLaren, E. H., The Freezing Points of High Purity Metals as Precision Temperature Standards. III. Thermal Analysis on Eight Grades of Zinc with Purities Greater than 99.99%, *Can. J. Phys.* 36, 585-598 (1958).

[76] McLaren, E. H. and Murdock, E. G., The Freezing Points of High Purity Metals as Precision Temperature Standards. V. Thermal Analyses on 10 Samples of Tin with Purities Greater than 99.99%, *Can. J. Phys.* 38, 100-118 (1960).

[77] Ohtsuka, M. and Bedford, R. E., Measurement of the thermodynamic temperature interval between the freezing points of silver and copper, Temperature, Its Measurement and Control in Science and Industry, Edited by J. F. Schooley, Vol. 5, Part 1, pp. 175-181 (American Institute of Physics, New York, 1982).

[78] Orlova, M. P., Astrov, D. N., Sharevskaya, D. I., Belyanskii, L. B., Razhba, Ya. E., and Khnykov, V. M., Primary State Standard for the Unit of Temperature in the Range of 13.81-273.15 K, *Measurement Techniques* 16, 477-482 (1973).

[79] Pavese, F., Ancsin, J., Astrov, D. N., Bonhoure, J., Bonnier, G., Furukawa, G. T., Kemp, R. C., Maas, H., Rusby, R. L., Sakurai, H., and Ling Shan-Kang, An International Intercomparison of Fixed Points by Means of Sealed Cells in the Range 13.81 K - 90.686 K, *Metrologia* 20, 127-144 (1984).

- [80] Pavese, F., The Triple Points of Argon and Oxygen, *Metrologia* 14, 93-103, (1978).
- [81] Peggs, G. N., Elliott, K. W. T., and Lewis, S., An Intercomparison Between a Primary Standard Mercury Barometer and a Gas-operated Pressure Balance Standard, *Metrologia* 15, 77-85 (1979).
- [82] Powell, R. L., Hall, W. J., Hyink, C. H. Jr., Sparks, L. L., Burns, G. W., Scroger, M. G., and Plumb, H. H., Thermocouple Reference Tables Based on the IPTS-68, NBS Monograph 125 (March 1974).
- [83] Preston-Thomas, H., The International Temperature Scale of 1990 (ITS-90), *Metrologia* 27, 3-10 (1990).
- [84] Procès-Verbaux des Séances du Comité International des Poids et Mesures, (78^e session, octobre 1989), in press.
- [85] Quinn, T. J., News from the BIPM, *Metrologia* 26, 69-74 (1989).
- [86] Quinn, T. J. and Chandler, T. R. D., The Freezing Point of Platinum Determined by the NPL Photoelectric Pyrometer, Temperature, Its Measurement and Control in Science and Industry, Edited by H. H. Plumb, Vol. 4, Part 1, pp. 295-309 (Instrument Society of America, Pittsburgh, PA, 1972).
- [87] Quinn, T. J., *Temperature* (Academic Press, Inc., New York, N. Y. (1983).
- [88] Ricci, J. E., *The Phase Rule and Heterogeneous Equilibrium*, (Dover Publications, Inc., New York, NY, 1966).
- [89] Righini, F., Rosso, A., and Ruffino, G., Temperature Dependence of Effective Wavelength in Optical Pyrometry, Temperature, Its Measurement and Control in Science and Industry, Edited by H. H. Plumb, Vol. 4, Part 1, pp. 413-421 (Instrument Society of America, Pittsburgh, PA, 1972).
- [90] Roberts, T. R., Sherman, R. H., and Sydoriak, S. G., The 1962 ³He Scale of Temperatures III. Evaluation and Status, *J. Res. Natl. Bur. Stands.* 68A, 567-578 (1964).
- [91] Rusby, R. L. and Swenson, C. A., A New Determination of the Helium Vapour Pressure Scales Using a CMN Magnetic Thermometer and the NPL-75 Gas Thermometer Scale, *Metrologia* 16, 73-87 (1980).
- [92] Sawada, S., Realization of the triple point of Indium in a sealed glass cell, Temperature, Its Measurement and Control in Science and Industry, Edited by J. F. Schooley, Vol. 5, Part 1, pp. 343-346 (American Institute of Physics, New York, 1982).
- [93] Simon, M., On the Phase Separation in the Liquid System Ne-pH₂, *Phys. Letters*, 5, 319 (1963).
- [94] Sostman, H. E., Melting point of gallium as a temperature calibration standard, *Rev. Sci. Instrum.* 48, 127-130 (1977).

- [95] Sparrow, E. M., Albers, L. U., and Eckert, E. R. G., Thermal Radiation Characteristics of Cylindrical Enclosures, J. Heat Transfer C84, 73-81 (1962).
- [96] Steur, P. P. M. and Durieux, M., Constant-Volume Gas Thermometry Between 4 K and 100 K, Metrologia 23, 1-18 (1986).
- [97] Streett, W. B. and D. H. Jones, Liquid Phase Separation and Liquid-vapor Equilibrium in the System Neon-Hydrogen, J. Chem. Phys. 42, 3989-3994 (1965).
- [98] Takiya, M., Precise Measurement of the Freezing Point of Silver with a Platinum Resistance Thermometer, Comitee Consultatif de Thermometrie. 12th Session, Annexe T30, T154-T159 (1978).
- [99] The 1976 Provisional 0.5 K to 30 K Temperature Scale, Metrologia 15, 65-68 (1979).
- [100] The International Practical Temperature Scale of 1968, Metrologia 5, 35-44 (1969).
- [101] The International Practical Temperature Scale of 1968, Amended Edition of 1975, Metrologia 12, 7-17 (1976).
- [102] Weber, S. and Schmidt, G., Experimentelle Untersuchungen über die Thermomolekulare Druckdifferenz in der Nähe der Grenzbedingung $p_1/p_2 = (T_1/T_2)^{1/2}$ und Vergleichung mit der Theorie, Leiden Communication 246C, 1-13 (1936).
- [103] Weeks, J. R., Liquidus Curves and Corrosion of Fe, Cr, Ni, Co, V, Cb, Ta, Ti, Zr, in 500-750 °C Mercury, Corrosion 23, 98-106 (1967).
- [104] Weitzel, D. H. and Park, O. E., Iron Catalyst for Production of Liquid *para*-Hydrogen, Rev. Sci. Instr. 27, 57-58 (1956).
- [105] Wise, Jacquelyn, Liquid-In-Glass Thermometer Calibration Service, NIST Special Publication 250-23 (September 1988).

6. APPENDICES

In these appendices, we present information on or copies of some of the relevant documents or meetings concerning the ITS-90, typical NIST calibration reports of thermometers, and membership of the National Conference of Standards Laboratories (NCSL) Ad Hoc Committee on the Change of the Temperature Scale

6.1 In this appendix, copies of, or excerpts from, some papers related to the work of the international bodies concerned with the ITS-90 are presented.

6.1.1 Reproduction of the article by H. Preston-Thomas, entitled, "The International Temperature Scale of 1990 (ITS-90)," published in *Metrologia* 27, 3-10 (1990), with corrections. Reprinted with permission of the BIPM.

This copy incorporates textual corrections detailed in Metrologia 27, 107 (1990)

The International Temperature Scale of 1990 (ITS-90)

H. Preston-Thomas

President of the Comité Consultatif de Thermométrie and Vice-President of the Comité International des Poids et Mesures
Division of Physics, National Research Council of Canada, Ottawa, K1A 0S1 Canada

Received: October 24, 1989

Introductory Note

The official French text of the ITS-90 is published by the BIPM as part of the Procès-verbaux of the Comité International des Poids et Mesures (CIPM). However, the English version of the text reproduced here has been authorized by the Comité Consultatif de Thermométrie (CCT) and approved by the CIPM.

The International Temperature Scale of 1990

The International Temperature Scale of 1990 was adopted by the International Committee of Weights and Measures at its meeting in 1989, in accordance with the request embodied in Resolution 7 of the 18th General Conference of Weights and Measures of 1987. This scale supersedes the International Practical Temperature Scale of 1968 (amended edition of 1975) and the 1976 Provisional 0,5 K to 30 K Temperature Scale.

1. Units of Temperature

The unit of the fundamental physical quantity known as thermodynamic temperature, symbol T , is the kelvin, symbol K, defined as the fraction $1/273,16$ of the thermodynamic temperature of the triple point of water¹.

Because of the way earlier temperature scales were defined, it remains common practice to express a temperature in terms of its difference from 273,15 K, the ice point. A thermodynamic temperature, T , expressed in this way is known as a Celsius temperature, symbol t , defined by:

$$t/^{\circ}\text{C} = T/\text{K} - 273,15. \quad (1)$$

¹ Comptes Rendus des Séances de la Treizième Conférence Générale des Poids et Mesures (1967–1968), Résolutions 3 and 4, p. 104

The unit of Celsius temperature is the degree Celsius, symbol $^{\circ}\text{C}$, which is by definition equal in magnitude to the kelvin. A difference of temperature may be expressed in kelvins or degrees Celsius.

The International Temperature Scale of 1990 (ITS-90) defines both International Kelvin Temperatures, symbol T_{90} , and International Celsius Temperatures, symbol t_{90} . The relation between T_{90} and t_{90} is the same as that between T and t , i.e.:

$$t_{90}/^{\circ}\text{C} = T_{90}/\text{K} - 273,15. \quad (2)$$

The unit of the physical quantity T_{90} is the kelvin, symbol K, and the unit of the physical quantity t_{90} is the degree Celsius, symbol $^{\circ}\text{C}$, as is the case for the thermodynamic temperature T and the Celsius temperature t .

2. Principles of the International Temperature Scale of 1990 (ITS-90)

The ITS-90 extends upwards from 0,65 K to the highest temperature practicably measurable in terms of the Planck radiation law using monochromatic radiation. The ITS-90 comprises a number of ranges and sub-ranges throughout each of which temperatures T_{90} are defined. Several of these ranges or sub-ranges overlap, and where such overlapping occurs, differing definitions of T_{90} exist: these differing definitions have equal status. For measurements of the very highest precision there may be detectable numerical differences between measurements made at the same temperature but in accordance with differing definitions. Similarly, even using one definition, at a temperature between defining fixed points two acceptable interpolating instruments (e.g. resistance thermometers) may give detectably differing numerical values of T_{90} . In virtually all cases these differences are of negligible practical importance and are at the minimum level consistent with a scale of no more than reasonable complexity: for further information on this point, see "Supplementary Information for the ITS-90" (BIPM-1990).

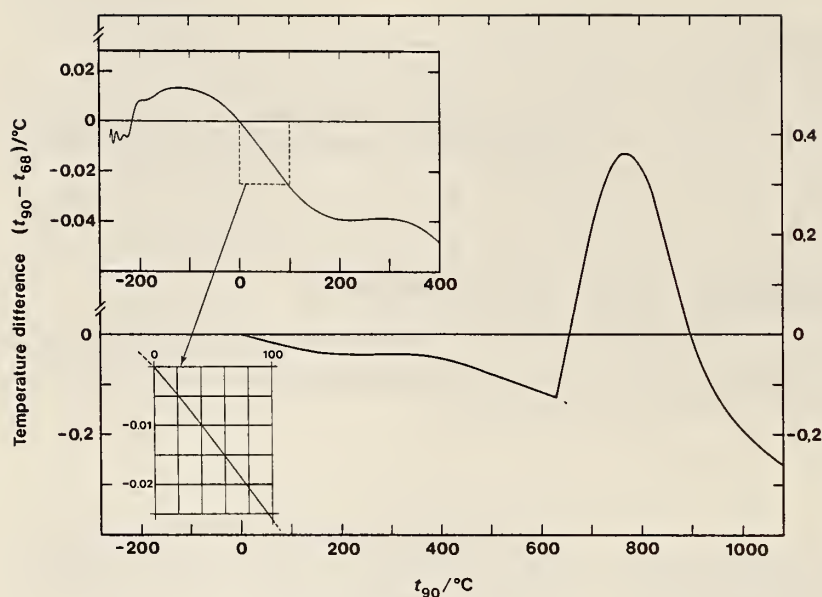

Fig. 1. The differences $(t_{90} - t_{68})$ as a function of Celsius temperature t_{90}

The ITS-90 has been constructed in such a way that, throughout its range, for any given temperature the numerical value of T_{90} is a close approximation to the numerical value of T according to best estimates at the time the scale was adopted. By comparison with direct measurements of thermodynamic temperatures, measurements of T_{90} are more easily made, are more precise and are highly reproducible.

There are significant numerical differences between the values of T_{90} and the corresponding values of T_{68} measured on the International Practical Temperature Scale of 1968 (IPTS-68), see Fig. 1 and Table 6. Similarly there were differences between the IPTS-68 and the International Practical Temperature Scale of 1948 (IPTS-48), and between the International Temperature Scale of 1948 (ITS-48) and the International Temperature Scale of 1927 (ITS-27). See the Appendix and, for more detailed information, "Supplementary Information for the ITS-90".

3. Definition of the International Temperature Scale of 1990

Between 0,65 K and 5,0 K T_{90} is defined in terms of the vapour-pressure temperature relations of ^3He and ^4He .

Between 3,0 K and the triple point of neon (24,5561 K) T_{90} is defined by means of a helium gas thermometer calibrated at three experimentally realizable temperatures having assigned numerical values (defining fixed points) and using specified interpolation procedures.

Between the triple point of equilibrium hydrogen (13,8033 K) and the freezing point of silver (961,78 °C) T_{90} is defined by means of platinum resistance thermometers calibrated at specified sets of defining fixed points and using specified interpolation procedures.

Above the freezing point of silver (961,78 °C) T_{90} is defined in terms of a defining fixed point and the Planck radiation law.

The defining fixed points of the ITS-90 are listed in Table 1. The effects of pressure, arising from significant depths of immersion of the sensor or from other causes, on the temperature of most of these points are given in Table 2.

3.1. From 0,65 K to 5,0 K: Helium Vapour-Pressure Temperature Equations

In this range T_{90} is defined in terms of the vapour pressure p of ^3He and ^4He using equations of the form:

$$T_{90}/\text{K} = A_0 + \sum_{i=1}^9 A_i [(\ln(p/\text{Pa}) - B)/C]^i \quad (3)$$

The values of the constants A_0 , A_i , B and C are given in Table 3 for ^3He in the range of 0,65 K to 3,2 K, and for ^4He in the ranges 1,25 K to 2,1768 K (the λ point) and 2,1768 K to 5,0 K.

3.2. From 3,0 K to the Triple Point of Neon (24,5561 K): Gas Thermometer

In this range T_{90} is defined in terms of a ^3He or a ^4He gas thermometer of the constant-volume type that has been calibrated at three temperatures. These are the triple point of neon (24,5561 K), the triple point of equilibrium hydrogen (13,8033 K), and a temperature between 3,0 K and 5,0 K. This last temperature is determined using a ^3He or a ^4He vapour pressure thermometer as specified in Sect. 3,1.

Table 1. Defining fixed points of the ITS-90

Number	Temperature		Substance ^a	State ^b	$W_r(T_{90})$
	T_{90}/K	$t_{90}/^\circ\text{C}$			
1	3 to 5	-270,15 to -268,15	He	V	
2	13,8033	-259,3467	e-H ₂	T	0,001 190 07
3	≈ 17	$\approx -256,15$	e-H ₂ (or He)	V (or G)	
4	$\approx 20,3$	$\approx -252,85$	e-H ₂ (or He)	V (or G)	
5	24,5561	-248,5939	Ne	T	0,008 449 74
6	54,3584	-218,7916	O ₂	T	0,091 718 04
7	83,8058	-189,3442	Ar	T	0,215 859 75
8	234,3156	-38,8344	Hg	T	0,844 142 11
9	273,16	0,01	H ₂ O	T	1,000 000 00
10	302,9146	29,7646	Ga	M	1,118 138 89
11	429,7485	156,5985	In	F	1,609 801 85
12	505,078	231,928	Sn	F	1,892 797 68
13	692,677	419,527	Zn	F	2,568 917 30
14	933,473	660,323	Al	F	3,376 008 60
15	1234,93	961,78	Ag	F	4,286 420 53
16	1337,33	1064,18	Au	F	
17	1357,77	1084,62	Cu	F	

^a All substances except ³He are of natural isotopic composition, e-H₂ is hydrogen at the equilibrium concentration of the ortho- and para-molecular forms

^b For complete definitions and advice on the realization of these various states, see "Supplementary Information for the ITS-90". The symbols have the following meanings: V: vapour pressure point; T: triple point (temperature at which the solid, liquid and vapour phases are in equilibrium); G: gas thermometer point; M, F: melting point, freezing point (temperature, at a pressure of 101 325 Pa, at which the solid and liquid phases are in equilibrium)

Table 2. Effect of pressure on the temperatures of some defining fixed points *

Substance	Assigned value of equilibrium temperature T_{90}/K	Temperature with pressure, p $(dT/dp)/(10^{-8} \text{ K} \cdot \text{Pa}^{-1})^*$	Variation with depth, l $(dT/dl)/(10^{-3} \text{ K} \cdot \text{m}^{-1})^{**}$
e-Hydrogen (T)	13,8033	34	0,25
Neon (T)	24,5561	16	1,9
Oxygen (T)	54,3584	12	1,5
Argon (T)	83,8058	25	3,3
Mercury (T)	234,3156	5,4	7,1
Water (T)	273,16	-7,5	-0,73
Gallium	302,9146	-2,0	-1,2
Indium	429,7485	4,9	3,3
Tin	505,078	3,3	2,2
Zinc	692,677	4,3	2,7
Aluminium	933,473	7,0	1,6
Silver	1234,93	6,0	5,4
Gold	1337,33	6,1	10
Copper	1357,77	3,3	2,6

* Equivalent to millikelvins per standard atmosphere

** Equivalent to millikelvins per metre of liquid

* The Reference pressure for melting and freezing points is the standard atmosphere ($p_0 = 101\,325 \text{ Pa}$). For triple points (T) the pressure effect is a consequence only of the hydrostatic head of liquid in the cell

Table 3. Values of the constants for the helium vapour pressure Eqs. (3), and the temperature range for which each equation, identified by its set of constants, is valid

	³ He 0,65 K to 3,2 K	⁴ He 1,25 K to 2,1768 K	⁴ He 2,1768 K to 5,0 K
A_0	1,053 447	1,392 408	3,146 631
A_1	0,980 106	0,527 153	1,357 655
A_2	0,676 380	0,166 756	0,413 923
A_3	0,372 692	0,050 988	0,091 159
A_4	0,151 656	0,026 514	0,016 349
A_5	-0,002 263	0,001 975	0,001 826
A_6	0,006 596	-0,017 976	-0,00 4325
A_7	0,088 966	0,005 409	-0,00 4973
A_8	-0,004 770	0,013 259	0
A_9	-0,054 943	0	0
B	7,3	5,6	10,3
C	4,3	2,9	1,9

3.2.1. From 4,2 K to the Triple Point of Neon (24,5561 K) with ⁴He as the Thermometric Gas. In this range T_{90} is defined by the relation:

$$T_{90} = a + b p + c p^2, \quad (4)$$

where p is the pressure in the gas thermometer and a , b and c are coefficients the numerical values of which are obtained from measurements made at the three defining fixed points given in Sect. 3.2, but with the further restriction that the lowest one of these points lies between 4,2 K and 5,0 K.

3.2.2. From 3,0 K to the Triple Point of Neon (24,5561 K) with ³He or ⁴He as the Thermometric Gas. For a ³He gas thermometer, and for a ⁴He gas thermometer used below 4,2 K, the non-ideality of the gas must be accounted for explicitly, using the appropriate second virial coefficient $B_3(T_{90})$ or $B_4(T_{90})$. In this range T_{90} is defined by the relation:

$$T_{90} = \frac{a + b p + c p^2}{1 + B_x(T_{90}) N/V}, \quad (5)$$

where p is the pressure in the gas thermometer, a , b and c are coefficients the numerical values of which are obtained from measurements at three defining temperatures as given in Sect. 3.2, N/V is the gas density with N being the quantity of gas and V the volume of the bulb, x is 3 or 4 according to the isotope used, and the values of the second virial coefficients are given by the relations:

For ³He,

$$B(T_{90})/\text{m}^3 \text{ mol}^{-1} = \{16,69 - 336,98 (T_{90}/\text{K})^{-1} + 91,04 (T_{90}/\text{K})^{-2} - 13,82 (T_{90}/\text{K})^{-3}\} 10^{-6}. \quad (6a)$$

For ⁴He,

$$B_4(T_{90})/\text{m}^3 \text{ mol}^{-1} = \{16,708 - 374,05 (T_{90}/\text{K})^{-1} - 383,53 (T_{90}/\text{K})^{-2} + 1799,2 (T_{90}/\text{K})^{-3} - 4033,2 (T_{90}/\text{K})^{-4} + 3252,8 (T_{90}/\text{K})^{-5}\} 10^{-6}. \quad (6b)$$

Table 4. The constants $A_0, A_i; B_0, B_i; C_0, C_i; D_0$ and D_i in the reference functions of equations (9a); (9b); (10a); and (10b) respectively

A_0	-2,135 347 29	B_0	0,183 324 722	B_{13}	-0,091 173 542
A_1	3,183 247 20	B_1	0,240 975 303	B_{14}	0,001 317 696
A_2	-1,801 435 97	B_2	0,209 108 771	B_{15}	0,026 025 526
A_3	0,717 272 04	B_3	0,190 439 972		
A_4	0,503 440 27	B_4	0,142 648 498		
A_5	-0,618 993 95	B_5	0,077 993 465		
A_6	-0,053 323 22	B_6	0,012 475 611		
A_7	0,280 213 62	B_7	-0,032 267 127		
A_8	0,107 152 24	B_8	-0,075 291 522		
A_9	-0,293 028 65	B_9	-0,056 470 670		
A_{10}	0,044 598 72	B_{10}	0,076 201 285		
A_{11}	0,118 686 32	B_{11}	0,123 893 204		
A_{12}	-0,052 481 34	B_{12}	-0,029 201 193		
C_0	2,781 572 54	D_0	439,932 854		
C_1	1,646 509 16	D_1	472,418 020		
C_2	-0,137 143 90	D_2	37,684 494		
C_3	-0,006 497 67	D_3	7,472 018		
C_4	-0,002 344 44	D_4	2,920 828		
C_5	0,005 118 68	D_5	0,005 184		
C_6	0,001 879 82	D_6	-0,963 864		
C_7	-0,002 044 72	D_7	-0,188 732		
C_8	-0,000 461 22	D_8	0,191 203		
C_9	0,000 457 24	D_9	0,049 025		

The accuracy with which T_{90} can be realized using Eqs. (4) and (5) depends on the design of the gas thermometer and the gas density used. Design criteria and current good practice required to achieve a selected accuracy are given in "Supplementary Information for the ITS-90".

3.3. The Triple Point of Equilibrium Hydrogen (13,8033 K) to the Freezing Point of Silver (961,78 °C): Platinum Resistance Thermometer

In this range T_{90} is defined by means of a platinum resistance thermometer calibrated at specified sets of defining fixed points, and using specified reference and deviation functions for interpolation at intervening temperatures.

No single platinum resistance thermometer can provide high accuracy, or is even likely to be usable, over all of the temperature range 13,8033 K to 961,78 °C. The choice of temperature range, or ranges, from among those listed below for which a particular thermometer can be used is normally limited by its construction.

For practical details and current good practice, in particular concerning types of thermometer available, their acceptable operating ranges, probable accuracies, permissible leakage resistance, resistance values, and thermal treatment, see "Supplementary Information for the ITS-90". It is particularly important to take account of the appropriate heat treatments that should be followed each time a platinum resistance thermometer is subjected to a temperature above about 420 °C.

Temperatures are determined in terms of the ratio of the resistance $R(T_{90})$ at a temperature T_{90} and the resis-

tance $R(273,16 \text{ K})$ at the triple point of water. This ratio, $W(T_{90})$, is ²:

$$W(T_{90}) = R(T_{90})/R(273,16 \text{ K}). \quad (7)$$

An acceptable platinum resistance thermometer must be made from pure, strain-free platinum, and it must satisfy at least one of the following two relations:

$$W(29,7646 \text{ °C}) \geq 1,118 07, \quad (8a)$$

$$W(-38,8344 \text{ °C}) \leq 0,844 235. \quad (8b)$$

An acceptable platinum resistance thermometer that is to be used up to the freezing point of silver must also satisfy the relation:

$$W(961,78 \text{ °C}) \geq 4,2844. \quad (8c)$$

In each of the resistance thermometer ranges, T_{90} is obtained from $W_r(T_{90})$ as given by the appropriate reference function {Eqs. (9b) or (10b)}, and the deviation $W(T_{90}) - W_r(T_{90})$. At the defining fixed points this deviation is obtained directly from the calibration of the thermometer: at intermediate temperatures it is obtained by means of the appropriate deviation function {Eqs. (12), (13) and (14)}.

(i) – For the range 13,8033 K to 273,16 K the following reference function is defined:

$$\ln [W_r(T_{90})] = A_0 + \sum_{i=1}^{12} A_i \left[\frac{\ln(T_{90}/273,16 \text{ K}) + 1,5}{1,5} \right]^i. \quad (9a)$$

An inverse function, equivalent to Eq. (9a) to within 0,1 mK, is:

$$T_{90}/273,16 \text{ K} = B_0 + \sum_{i=1}^{15} B_i \left[\frac{W_r(T_{90})^{1/6} - 0,65}{0,35} \right]^i. \quad (9b)$$

The values of the constants A_0, A_i, B_0 and B_i are given in Table 4.

A thermometer may be calibrated for use throughout this range or, using progressively fewer calibration points, for ranges with low temperature limits of 24,5561 K, 54,3584 K and 83,8058 K, all having an upper limit of 273,16 K.

(ii) – For the range 0 °C to 961,78 °C the following reference function is defined:

$$W_r(T_{90}) = C_0 + \sum_{i=1}^9 C_i \left[\frac{T_{90}/\text{K} - 754,15}{481} \right]^i. \quad (10a)$$

An inverse function, equivalent to equation (10a) to within 0,13 mK is:

$$T_{90}/\text{K} - 273,15 = D_0 + \sum_{i=1}^9 D_i \left[\frac{W_r(T_{90}) - 2,64}{1,64} \right]^i. \quad (10b)$$

The values of the constants C_0, C_i, D_0 and D_i are given in Table 4.

² Note that this definition of $W(T_{90})$ differs from the corresponding definition used in the ITS-27, ITS-48, IPTS-48, and IPTS-68: for all of these earlier scales $W(T)$ was defined in terms of a reference temperature of 0 °C, which since 1954 has itself been defined as 273,15 K.

A thermometer may be calibrated for use throughout this range or, using fewer calibration points, for ranges with upper limits of 660,323°C, 419,527°C, 231,928°C, 156,5985°C or 29,7646°C, all having a lower limit of 0°C.

(iii) – A thermometer may be calibrated for use in the range 234,3156 K (–38,8344°C) to 29,7646°C, the calibration being made at these temperatures and at the triple point of water. Both reference functions {Eqs. (9) and (10)} are required to cover this range.

The defining fixed points and deviation functions for the various ranges are given below, and in summary form in Table 5.

3.3.1. The Triple Point of Equilibrium Hydrogen (13,8033 K) to the Triple Point of Water (273,16 K). The thermometer is calibrated at the triple points of equilibrium hydrogen (13,8033 K), neon (24,5561 K), oxygen (54,3584 K), argon (83,8058 K), mercury (234,3156 K), and water (273,16 K), and at two additional temperatures close to 17,0 K and 20,3 K. These last two may be determined either: by using a gas thermometer as described in Sect. 3.2, in which case the two temperatures must lie within the ranges 16,9 K to 17,1 K and 20,2 K to 20,4 K respectively; or by using the vapour pressure-temperature relation of equilibrium hydrogen, in which case the two temperatures must lie within the ranges 17,025 K to 17,045 K and 20,26 K to 20,28 K respectively, with the precise values being determined from Eqs. (11 a) and (11 b) respectively:

$$T_{90}/K - 17,035 = (p/kPa - 33,3213)/13,32 \quad (11 a)$$

$$T_{90}/K - 20,27 = (p/kPa - 101,292)/30. \quad (11 b)$$

The deviation function is³:

$$W(T_{90}) - W_r(T_{90}) = a[W(T_{90}) - 1] + b[W(T_{90}) - 1]^2 + \sum_{i=1}^5 c_i [\ln W(T_{90})]^{i+n} \quad (12)$$

with values for the coefficients a , b and c_i being obtained from measurements at the defining fixed points and with $n=2$.

For this range and for the sub-ranges 3.3.1.1 to 3.3.1.3 the required values of $W_r(T_{90})$ are obtained from Eq. (9a) or from Table 1.

3.3.1.1. The Triple Point of Neon (24,5561 K) to the Triple Point of Water (273,16 K). The thermometer is calibrated at the triple points of equilibrium hydrogen (13,8033 K), neon (24,5561 K), oxygen (54,3584 K), argon (83,8058 K), mercury (234,3156 K) and water (273,16 K).

The deviation function is given by Eq. (12) with values for the coefficients a , b , c_1 , c_2 and c_3 being obtained from measurements at the defining fixed points and with $c_4 = c_5 = n = 0$.

3.3.1.2. The Triple Point of Oxygen (54,3584 K) to the Triple Point of Water (273,16 K). The thermometer is

³ This deviation function {and also those of Eqs. (13) and (14)} may be expressed in terms of W_r rather than W : for this procedure see "Supplementary Information for ITS-90"

Table 5. Deviation functions and calibration points for platinum resistance thermometers in the various ranges in which they define T_{90}

<i>a</i> Ranges with an upper limit of 273,16 K			
Section	Lower temperature limit T/K	Deviation functions	Calibration points (see Table 1)
3.3.1	13,8033	$a[W(T_{90}) - 1] + b[W(T_{90}) - 1]^2 + \sum_{i=1}^5 c_i [\ln W(T_{90})]^{i+n}$, $n=2$	2-9
3.3.1.1	24,5561	As for 3.3.1 with $c_4 = c_5 = n = 0$	2, 5-9
3.3.1.2	54,3584	As for 3.3.1 with $c_2 = c_3 = c_4 = c_5 = 0$, $n=1$	6-9
3.3.1.3	83,8058	$a[W(T_{90}) - 1] + b[W(T_{90}) - 1] \ln W(T_{90})$	7-9
<i>b</i> Ranges with a lower limit of 0°C			
Section	Upper temperature limit t_i /°C	Deviation functions	Calibration points (see Table 1)
3.3.2*	961,78	$a[W(T_{90}) - 1] + b[W(T_{90}) - 1]^2 + c[W(T_{90}) - 1]^3 + d[W(T_{90}) - W(660,323^\circ\text{C})]^2$	9, 12-15
3.3.2.1	660,323	As for 3.3.2 with $d=0$	9, 12-14
3.3.2.2	419,527	As for 3.3.2 with $c=d=0$	9, 12, 13
3.3.2.3	231,928	As for 3.3.2 with $c=d=0$	9, 11, 12
3.3.2.4	156,5985	As for 3.3.2 with $b=c=d=0$	9, 11
3.3.2.5	29,7646	As for 3.3.2 with $b=c=d=0$	9, 10
<i>c</i> Range from 234,3156 K (–38,8344°C) to 29,7646°C			
3.3.3		As for 3.3.2 with $c=d=0$	8-10

* Calibration points 9, 12-14 are used with $d=0$ for $t_{90} \leq 660,323^\circ\text{C}$; the values of a , b and c thus obtained are retained for $t_{90} > 660,323^\circ\text{C}$, with d being determined from calibration point 15

calibrated at the triple points of oxygen (54,3584 K), argon (83,8058 K), mercury (234,3156 K) and water (273,16 K).

The deviation function is given by Eq. (12) with values for the coefficients a , b and c_1 being obtained from measurements at the defining fixed points, with $c_2 = c_3 = c_4 = c_5 = 0$ and with $n=1$.

3.3.1.3. The Triple Point of Argon (83,8058 K) to the Triple Point of Water (273,16 K). The thermometer is calibrated at the triple points of argon (83,8058 K), mercury (234,3156 K) and water (273,16 K).

The deviation function is:

$$W(T_{90}) - W_r(T_{90}) = a[W(T_{90}) - 1] + b[W(T_{90}) - 1] \ln W(T_{90}) \quad (13)$$

with the values of a and b being obtained from measurements at the defining fixed points.

3.3.2. From 0°C to the Freezing Point of Silver (961,78°C). The thermometer is calibrated at the triple

point of water (0,01 °C), and at the freezing points of tin (231,928 °C), zinc (419,527 °C), aluminium (660,323 °C) and silver (961,78 °C).

The deviation function is:

$$W(T_{90}) - W_r(T_{90}) = a[W(T_{90}) - 1] + b[W(T_{90}) - 1]^2 + c[W(T_{90}) - 1]^3 + d[W(T_{90}) - W(660,323 \text{ °C})]^2 \quad (14)$$

For temperatures below the freezing point of aluminium $d=0$, with the values of a , b and c being determined from the measured deviations from $W_r(T_{90})$ at the freezing points of tin, zinc and aluminium. From the freezing point of aluminium to the freezing point of silver the above values of a , b and c are retained and the value of d is determined from the measured deviation from $W_r(T_{90})$ at the freezing point of silver.

For this range and for the sub-ranges 3.3.2.1 to 3.3.2.5 the required values for $W_r(T_{90})$ are obtained from Eq. (10a) or from Table 1.

3.3.2.1. From 0 °C to the Freezing Point of Aluminium (660,323 °C). The thermometer is calibrated at the triple point of water (0,01 °C), and at the freezing points of tin (231,928 °C), zinc (419,527 °C) and aluminium (660,323 °C).

The deviation function is given by Eq. (14), with the values of a , b and c being determined from measurements at the defining fixed points and with $d=0$.

3.3.2.2. From 0 °C to the Freezing Point of Zinc (419,527 °C). The thermometer is calibrated at the triple point of water (0,01 °C), and at the freezing points of tin (231,928 °C) and zinc (419,527 °C).

The deviation function is given by Eq. (14) with the values of a and b being obtained from measurements at the defining fixed points and with $c=d=0$.

3.3.2.3. From 0 °C to the Freezing Point of Tin (231,928 °C). The thermometer is calibrated at the triple point of water (0,01 °C), and at the freezing points of indium (156,5985 °C) and tin (231,928 °C).

The deviation function is given by Eq. (14) with the values of a and b being obtained from measurements at the defining fixed points and with $c=d=0$.

3.3.2.4. From 0 °C to the Freezing Point of Indium (156,5985 °C). The thermometer is calibrated at the triple point of water (0,01 °C), and at the freezing point of indium (156,5985 °C).

The deviation function is given by Eq. (14) with the value of a being obtained from measurements at the defining fixed points and with $b=c=d=0$.

3.3.2.5. From 0 °C to the Melting Point of Gallium (29,7646 °C). The thermometer is calibrated at the triple point of water (0,01 °C), and at the melting point of gallium (29,7646 °C).

The deviation function is given by Eq. (14) with the value of a being obtained from measurements at the defining fixed points and with $b=c=d=0$.

3.3.3. The Triple Point of Mercury (−38,8344 °C) to the Melting Point of Gallium (29,7646 °C). The thermometer

is calibrated at the triple points of mercury (−38,8344 °C), and water (0,01 °C), and at the melting point of gallium (29,7646 °C).

The deviation function is given by Eq. (14) with the values of a and b being obtained from measurements at the defining fixed points and with $c=d=0$.

The required values of $W_r(T_{90})$ are obtained from Eqs. (9a) and (10a) for measurements below and above 273,16 K respectively, or from Table 1.

3.4. The Range Above the Freezing Point of Silver (961,78 °C): Planck Radiation Law

Above the freezing point of silver the temperature T_{90} is defined by the equation:

$$\frac{L_\lambda(T_{90})}{L_\lambda(T_{90}(X))} = \frac{\exp(c_2[\lambda T_{90}(X)]^{-1}) - 1}{\exp(c_2[\lambda T_{90}]^{-1}) - 1} \quad (15)$$

where $T_{90}(X)$ refers to any one of the silver $\{T_{90}(\text{Ag}) = 1234,93 \text{ K}\}$, the gold $\{T_{90}(\text{Au}) = 1337,33 \text{ K}\}$ or the copper $\{T_{90}(\text{Cu}) = 1357,77 \text{ K}\}$ freezing points⁴ and in which $L_\lambda(T_{90})$ and $L_\lambda[T_{90}(X)]$ are the spectral concentrations of the radiance of a blackbody at the wavelength (in vacuo) λ at T_{90} and at $T_{90}(X)$ respectively, and $c_2 = 0,014388 \text{ m} \cdot \text{K}$.

For practical details and current good practice for optical pyrometry, see "Supplementary Information for the ITS-90" (BIPM-1990).

4. Supplementary Information and Differences from Earlier Scales

The apparatus, methods and procedures that will serve to realize the ITS-90 are given in "Supplementary Information for the ITS-90". This document also gives an account of the earlier International Temperature Scales and the numerical differences between successive scales that include, where practicable, mathematical functions for the differences $T_{90} - T_{68}$. A number of useful approximations to the ITS-90 are given in "Techniques for Approximating the ITS-90".

These two documents have been prepared by the Comité Consultatif de Thermométrie and are published by the BIPM; they are revised and updated periodically.

The differences $T_{90} - T_{68}$ are shown in Fig. 1 and Table 6. The number of significant figures given in Table 6 allows smooth interpolations to be made. However, the reproducibility of the IPTS-68 is, in many areas, substantially worse than is implied by this number.

⁴ The T_{90} values of the freezing points of silver, gold and copper are believed to be self consistent to such a degree that the substitution of any one of them in place of one of the other two as the reference temperature $T_{90}(X)$ will not result in significant differences in the measured values of T_{90} .

Table 6. Differences between ITS-90 and EPT-76, and between ITS-90 and IPTS-68 for specified values of T_{90} and t_{90}

		$(T_{90} - T_{76})/\text{mK}$									
T_{90}/K	0	1	2	3	4	5	6	7	8	9	
0						-0,1	-0,2	-0,3	-0,4	-0,5	
10	-0,6	-0,7	-0,8	-1,0	-1,1	-1,3	-1,4	-1,6	-1,8	-2,0	
20	-2,2	-2,5	-2,7	-3,0	-3,2	-3,5	-3,8	-4,1			
		$(T_{90} - T_{68})/\text{K}$									
T_{90}/K	0	1	2	3	4	5	6	7	8	9	
10					-0,006	-0,003	-0,004	-0,006	-0,008	-0,009	
20	-0,009	-0,008	-0,007	-0,007	-0,006	-0,005	-0,004	-0,004	-0,005	-0,006	
30	-0,006	-0,007	-0,008	-0,008	-0,008	-0,007	-0,007	-0,007	-0,006	-0,006	
40	-0,006	-0,006	-0,006	-0,006	-0,006	-0,007	-0,007	-0,007	-0,006	-0,006	
50	-0,006	-0,005	-0,005	-0,004	-0,003	-0,002	-0,001	0,000	0,001	0,002	
60	0,003	0,003	0,004	0,004	0,005	0,005	0,006	0,006	0,007	0,007	
70	0,007	0,007	0,007	0,007	0,007	0,008	0,008	0,008	0,008	0,008	
80	0,008	0,008	0,008	0,008	0,008	0,008	0,008	0,008	0,008	0,008	
90	0,008	0,008	0,008	0,008	0,008	0,008	0,008	0,009	0,009	0,009	
T_{90}/K	0	10	20	30	40	50	60	70	80	90	
100	0,009	0,011	0,013	0,014	0,014	0,014	0,014	0,013	0,012	0,012	
200	0,011	0,010	0,009	0,008	0,007	0,005	0,003	0,001			
		$(t_{90} - t_{68})/^{\circ}\text{C}$									
$t_{90}/^{\circ}\text{C}$	0	-10	-20	-30	-40	-50	-60	-70	-80	-90	
-100	0,013	0,013	0,014	0,014	0,014	0,013	0,012	0,010	0,008	0,008	
0	0,000	0,002	0,004	0,006	0,008	0,009	0,010	0,011	0,012	0,012	
$t_{90}/^{\circ}\text{C}$	0	10	20	30	40	50	60	70	80	90	
0	0,000	-0,002	-0,005	-0,007	-0,010	-0,013	-0,016	-0,018	-0,021	-0,024	
100	-0,026	-0,028	-0,030	-0,032	-0,034	-0,036	-0,037	-0,038	-0,039	-0,039	
200	-0,040	-0,040	-0,040	-0,040	-0,040	-0,040	-0,040	-0,039	-0,039	-0,039	
300	-0,039	-0,039	-0,039	-0,040	-0,040	-0,041	-0,042	-0,043	-0,045	-0,046	
400	-0,048	-0,051	-0,053	-0,056	-0,059	-0,062	-0,065	-0,068	-0,072	-0,075	
500	-0,079	-0,083	-0,087	-0,090	-0,094	-0,098	-0,101	-0,105	-0,108	-0,112	
600	-0,115	-0,118	-0,122	-0,125*	-0,08	-0,03	0,02	0,06	0,11	0,16	
700	0,20	0,24	0,28	0,31	0,33	0,35	0,36	0,36	0,36	0,35	
800	0,34	0,32	0,29	0,25	0,22	0,18	0,14	0,10	0,06	0,03	
900	-0,01	-0,03	-0,06	-0,08	-0,10	-0,12	-0,14	-0,16	-0,17	-0,18	
1000	-0,19	-0,20	-0,21	-0,22	-0,23	-0,24	-0,25	-0,25	-0,26	-0,26	
$t_{90}/^{\circ}\text{C}$	0	100	200	300	400	500	600	700	800	900	
1000		-0,26	-0,30	-0,35	-0,39	-0,44	-0,49	-0,54	-0,60	-0,66	
2000	-0,72	-0,79	-0,85	-0,93	-1,00	-1,07	-1,15	-1,24	-1,32	-1,41	
3000	-1,50	-1,59	-1,69	-1,78	-1,89	-1,99	-2,10	-2,21	-2,32	-2,43	

* A discontinuity in the first derivative of $(t_{90} - t_{68})$ occurs at a temperature of $t_{90} = 630,6^{\circ}\text{C}$, at which $(t_{90} - t_{68}) = -0,125^{\circ}\text{C}$

Appendix

The International Temperature Scale of 1927 (ITS-27)

The International Temperature Scale of 1927 was adopted by the seventh General Conference of Weights and Measures to overcome the practical difficulties of the direct realization of thermodynamic temperatures by gas thermometry, and as a universally acceptable replacement for the differing existing national temperature scales. The ITS-27 was formulated so as to allow measurements of temperature to be made precisely and reproducibly, with as close an approximation to thermodynamic temperatures as could be determined at that time. Between the oxygen boiling point and the gold freezing point it was based upon a number of reproducible temperatures, or fixed points, to which numerical values were assigned, and two standard interpolating instruments. Each of these interpolating instruments was calibrated at several of the fixed points, thus giving the constants for the interpolating formula in the appropriate temperature range. A platinum resistance thermometer was used for the lower part and a platinum rhodium/platinum thermocouple for

temperatures above 660°C . For the region above the gold freezing point, temperatures were defined in terms of the Wien radiation law: in practice, this invariably resulted in the selection of an optical pyrometer as the realizing instrument.

The International Temperature Scale of 1948 (ITS-48)

The International Temperature Scale of 1948 was adopted by the ninth General Conference. Changes from the ITS-27 were: the lower limit of the platinum resistance thermometer range was changed from -190°C to the defined oxygen boiling point of $-182,97^{\circ}\text{C}$, and the junction of the platinum resistance thermometer range and the thermocouple range became the measured antimony freezing point (about 630°C) in place of 660°C ; the silver freezing point was defined as being $960,8^{\circ}\text{C}$ instead of $960,5^{\circ}\text{C}$; the gold freezing point replaced the gold melting point (1063°C); the Planck radiation law replaced the Wien law; the value assigned to the second radiation constant became $1,438 \times 10^{-2} \text{ m} \cdot \text{K}$ in place of $1,432 \times 10^{-2} \text{ m} \cdot \text{K}$; the permitted ranges for the constants of the interpo-

tion formulae for the standard resistance thermometer and thermocouple were modified; the limitation on λT for optical pyrometry ($\lambda T < 3 \times 10^{-3} \text{ m} \cdot \text{K}$) was changed to the requirement that "visible" radiation be used.

The International Practical Temperature Scale of 1948 (Amended Edition of 1960) (IPTS-48)

The International Practical Temperature Scale of 1948, amended edition of 1960, was adopted by the eleventh General Conference: the tenth General Conference had already adopted the triple point of water as the sole point defining the kelvin, the unit of thermodynamic temperature. In addition to the introduction of the word "Practical", the modifications to the ITS-48 were: the triple point of water, defined as being $0,01^\circ\text{C}$, replaced the melting point of ice as the calibration point in this region; the freezing point of zinc, defined as being $419,505^\circ\text{C}$, became a preferred alternative to the sulphur boiling point ($444,6^\circ\text{C}$) as a calibration point; the permitted ranges for the constants of the interpolation formulae for the standard resistance thermometer and the thermocouple were further modified; the restriction to "visible" radiation for optical pyrometry was removed.

Inasmuch as the numerical values of temperature on the IPTS-48 were the same as on the ITS-48, the former was not a revision of the scale of 1948 but merely an amended form of it.

The International Practical Temperature Scale of 1968 (IPTS-68)

In 1968 the International Committee of Weights and Measures promulgated the International Practical Temperature Scale of 1968, having been empowered to do so by the thirteenth General Conference of 1967–1968. The IPTS-68 incorporated very extensive changes from the IPTS-48. These included numerical changes, designed to bring it more nearly in accord with thermodynamic temperatures, that were sufficiently large to be apparent to many users. Other changes were as follows: the lower limit of the scale was extended down to 13,81 K; at even lower temperatures (0,5 K to 5,2 K), the use of two helium vapour pressure scales was recommended; six new defining fixed points were introduced – the triple point of equilibrium hydrogen (13,81 K), an intermediate equilibrium hydrogen point (17,042 K), the normal boiling point of equilibrium hydrogen (20,28 K), the boiling point of neon (27,102 K), the triple point of oxygen (54,361 K), and the freezing point of tin (231,9681 $^\circ\text{C}$) which became a permitted alternative to the boiling point of water; the boiling point of sulphur was deleted; the values assigned to four fixed points were changed – the boiling point of oxygen (90,188 K), the freezing point of zinc (419,58 $^\circ\text{C}$), the freezing point of silver (961,93 $^\circ\text{C}$), and the freezing point of gold

(1064,43 $^\circ\text{C}$); the interpolating formulae for the resistance thermometer range became much more complex; the value assigned to the second radiation constant c_2 became $1,4388 \times 10^{-2} \text{ m} \cdot \text{K}$; the permitted ranges of the constants for the interpolation formulae for the resistance thermometer and thermocouple were again modified.

The International Practical Temperature Scale of 1968 (Amended Edition of 1975) (IPTS-68)

The International Practical Temperature Scale of 1968, amended edition of 1975, was adopted by the fifteenth General Conference in 1975. As was the case for the IPTS-48 with respect to the ITS-48, the IPTS-68 (75) introduced no numerical changes. Most of the extensive textural changes were intended only to clarify and simplify its use. More substantive changes were: the oxygen point was defined as the condensation point rather than the boiling point; the triple point of argon (83,798 K) was introduced as a permitted alternative to the condensation point of oxygen; new values of the isotopic composition of naturally occurring neon were adopted; the recommendation to use values of T given by the 1958 ^4He and 1962 ^3He vapour-pressure scales was rescinded.

The 1976 Provisional 0,5 K to 30 K Temperature Scale (EPT-76)

The 1976 Provisional 0,5 K to 30 K Temperature Scale was introduced to meet two important requirements: these were to provide means of substantially reducing the errors (with respect to corresponding thermodynamic values) below 27 K that were then known to exist in the IPTS-68 and throughout the temperature ranges of the ^4He and ^3He vapour pressure scales of 1958 and 1962 respectively, and to bridge the gap between 5,2 K and 13,81 K in which there had not previously been an international scale. Other objectives in devising the EPT-76 were "that it should be thermodynamically smooth, that it should be continuous with the IPTS-68 at 27,1 K, and that it should agree with thermodynamic temperature T as closely as these two conditions allow". In contrast with the IPTS-68, and to ensure its rapid adoption, several methods of realizing the EPT-76 were approved. These included: using a thermodynamic interpolation instrument and one or more of eleven assigned reference points: taking differences from the IPTS-68 above 13,81 K; taking differences from helium vapour pressure scales below 5 K; and taking differences from certain well-established laboratory scales. Because there was a certain "lack of internal consistency" it was admitted that "slight ambiguities between realizations" might be introduced. However the advantages gained by adopting the EPT-76 as a working scale until such time as the IPTS-68 should be revised and extended were considered to outweigh the disadvantages.

6.1.2 Reproduction of the article by T. J. Quinn, entitled "News from the BIPM", published in *Metrologia* 26, 69-74 (1989).

News from the BIPM

T. J. Quinn

Bureau International des Poids et Mesures, Pavillon de Breteuil, F-92312 Sèvres Cedex, France

Received: October 14, 1988

Comité International des Poids et Mesures

77th Meeting

The Comité International des Poids et Mesures (CIPM) at its 77th Meeting, held at the Pavillon de Breteuil on the 4th, 5th and 6th of October 1988, adopted two important Recommendations concerning the use of the Josephson effect and the quantum Hall effect for maintaining reference standards for the measurement of emf and resistance. These Recommendations are based upon proposals made to the CIPM by its Comité Consultatif d'Electricité (CCE) which met in September 1988. The CCE proposals were the result of a great deal of work and discussion that had taken place among representatives of the national standards laboratories and the BIPM, particularly over the past twelve months.

New determinations of the SI volt and ohm, directly by realizations of the SI definitions and indirectly through determinations of the relevant fundamental physical constants, have established the values of the Josephson constant K_J and the von Klitzing constant R_K of the quantum Hall effect with uncertainties of a few parts in 10^7 . The constants K_J and R_K were assumed by the CCE to be equal to $2e/h$ and h/e^2 respectively for the purpose of including determinations of fundamental constants in their evaluation. The reproducibility, however, of the emf across a Josephson junction and the resistance of a quantum Hall device is much better than a few parts in 10^7 and approaches one part in 10^8 . Furthermore, the value of $2e/h$ suggested by the CCE in 1972 is now known to be in error by about 8 parts in 10^6 , although not all national standards laboratories are using this value.

In order to unify world reference standards of emf and allow users to take advantage of the great reproducibility of the Josephson effect and the quantum Hall effect, the CIPM acted on the advice of the CCE and adopted particular values of K_J and R_K , designated K_{J-90} and R_{K-90} , for use by all laboratories beginning on 1st January 1990. For those countries

that have based their reference standard of emf on the Josephson junction and use the 1972 CCE value for $2e/h$, the adoption of the new value for K_J will lead to a change in their reference standards of about 8 parts in 10^6 , i.e. 8 μV per volt. For the countries using values of K_J which differ from the 1972 CCE value, the changes will be within the range of about 9 to 3.5 parts in 10^6 .

Also 1st January 1990 it is expected that a new international temperature scale, the International Temperature Scale of 1990 (ITS-90), will come into effect, which will replace the International Practical Temperature Scale of 1968 (IPTS-68). The differences between ITS-90 and IPTS-68 are significant; not only are the scales substantially different in definition but temperatures measured on the ITS-90 differ significantly from those measured on the IPTS-68. For example, near room temperature: for $t_{68} \approx 20^\circ\text{C}$ the difference $T_{90} - T_{68} \approx -5\text{ mK}$ and for $t_{68} \approx 100^\circ\text{C}$ the difference $T_{90} - T_{68} \approx -25\text{ mK}$. The normal boiling point of water thus will be about 99.97°C and not 100.00°C as in the past.

It is important that users be made aware of these changes in electrical and temperature reference standards well in advance of their introduction. For this reason the 18th Conférence Générale des Poids et Mesures asked the CIPM to announce one year in advance, namely at the beginning of 1989, the magnitude of the changes consequent upon their coming into effect.

These official announcements are now made in the following three CIPM recommendations:

Representation of the volt by means of the Josephson effect

Recommendation 1 (CI-1988)

The Comité International des Poids et Mesures, acting in accordance with instructions given in Resolution 6 of the 18th Conférence Générale des Poids et

Reprinted with permission of BIPM.

Mesures concerning the forthcoming adjustment of the representations of the volt and the ohm,

considering

– that a detailed study of the results of the most recent determinations leads to a value of 483 597.9 GHz/V for the Josephson constant, K_J , that is to say, for the quotient of frequency divided by the potential difference corresponding to the $n = 1$ step in the Josephson effect,

– that the Josephson effect together with this value of K_J can be used to establish a reference standard of electromotive force having a one-standard-deviation uncertainty with respect to the volt estimated to be 4 parts in 10^7 , and a reproducibility which is significantly better,

recommends

– that 483 597.9 GHz/V exactly be adopted as a conventional value, denoted by K_{J-90} , for the Josephson constant, K_J ,

– that this new value be used from 1st January 1990, and not before, to replace the values currently in use,

– that this new value be used from this same date by all laboratories which base their measurements of electromotive force on the Josephson effect, and

– that from this same date all other laboratories adjust the value of their laboratory reference standards to agree with the new adopted value,

is of the opinion

– that no change in this recommended value of the Josephson constant will be necessary in the foreseeable future, and

draws the attention of laboratories to the fact that the new value is greater by 3.9 GHz/V, or about 8 parts in 10^6 , than the value given in 1972 by the Comité Consultatif d'Electricité in its Declaration E-72.

Representation of the ohm by means of the quantum Hall effect

Recommendation 2 (CI-1988)

The Comité International des Poids et Mesures, acting in accordance with instructions given in Resolution 6 of the 18th Conférence Générale des Poids et Mesures concerning the forthcoming adjustment of the representations of the volt and the ohm,

considering

– that most existing laboratory reference standards of resistance change significantly with time,

– that a laboratory reference standard of resistance based on the quantum Hall effect would be stable and reproducible,

– that a detailed study of the results of the most recent determinations leads to a value of 25 812.807 Ω for the von Klitzing constant, R_K , that is to say, for the quotient of the Hall potential difference divided by current corresponding to the plateau $i = 1$ in the quantum Hall effect,

– that the quantum Hall effect, together with this value of R_K , can be used to establish a reference standard of resistance having a one-standard-deviation uncertainty with respect to the ohm estimated to be 2 parts in 10^7 , and a reproducibility which is significantly better,

recommends

– that 25 812.807 Ω exactly be adopted as a conventional value, denoted by R_{K-90} , for the von Klitzing constant, R_K ,

– that this value be used from 1st January 1990, and not before, by all laboratories which base their measurements of resistance on the quantum Hall effect,

– that from this same date all other laboratories adjust the value of their laboratory reference standards to agree with R_{K-90} ,

– that in the use of the quantum Hall effect to establish a laboratory reference standard of resistance, laboratories follow the most recent edition of the technical guidelines for reliable measurements of the quantized Hall resistance drawn up by the Comité Consultatif d'Electricité and published by the Bureau International des Poids et Mesures, and

is of the opinion

– that no change in this recommended value of the von Klitzing constant will be necessary in the foreseeable future.

Preparation of the International Temperature Scale of 1990 (ITS-90)

Recommendation 3 (CI-1988)

The Comité International des Poids et Mesures, acting in accordance with instructions given in Resolution 7 of the 18th Conférence Générale des Poids et Mesures concerning the preparation of the new international temperature scale, announces that the differences between the ITS-90 and the IPTS-68 will be approximately those indicated in the graph attached to this Recommendation, recommends that national laboratories take note of these differences with a view to the implementation of the ITS-90 on 1st January 1990.

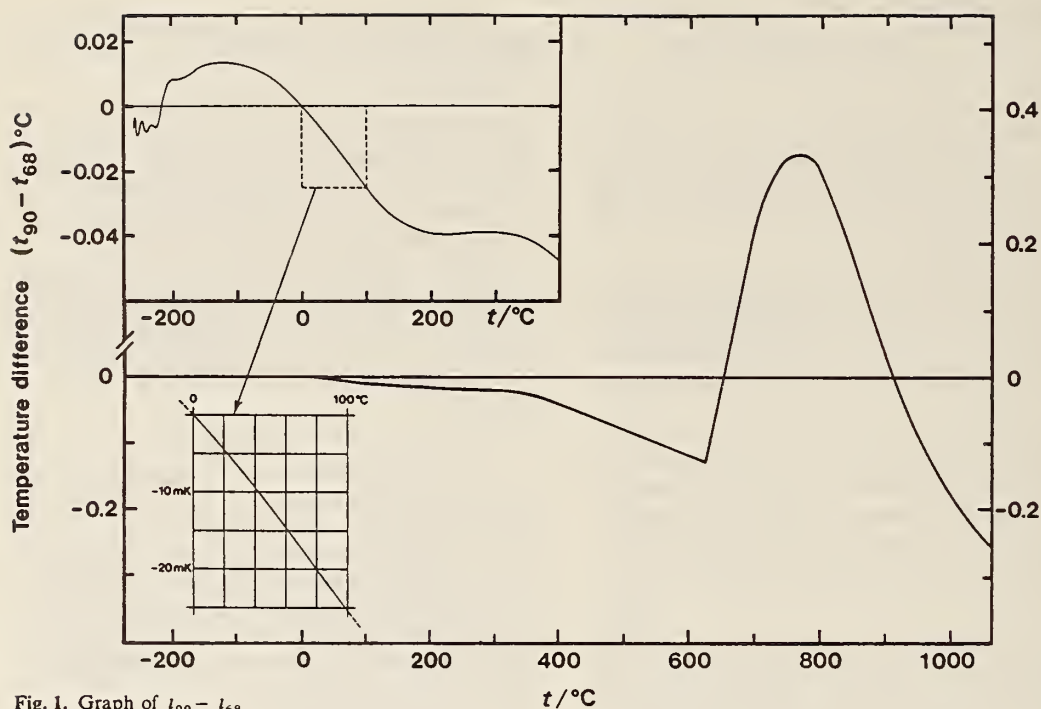

Fig. 1. Graph of $t_{90} - t_{68}$

Comité Consultatif d'Electricité

18th Meeting

The CCE at its meeting in September 1988 considered very carefully the way in which the recommended values for K_J and R_K (defined above) be used. Although no formal recommendation was made on this point, the following four statements were drafted and unanimously approved by the CCE and subsequently supported by the CIPM¹:

1.1. Recommendations 1 (CI-1988) and 2 (CI-1988) do not constitute a redefinition of SI units

The conventional values K_{J-90} and R_{K-90} cannot be used as bases for defining the volt and ohm (meaning the present volt and ohm units in the *Système International d'Unités*). To do so would change the status of μ_0 from that of a constant having an exactly defined value (and would therefore abrogate the definition of the ampere) and would also produce electrical units which would be incompatible with the definition of the kilogram and units derived from it.

¹ Because the original draft CCE recommendations were slightly modified by the CIPM, I have chosen to refer here only to the CIPM designations, i.e., CI-1988.

1.2. Concerning the use of subscripts on symbols for quantities or units

The CCE considers that symbols for electromotive force (electric potential, electric potential difference) and electric resistance, and for the volt and the ohm, should not be modified by adding suffixes to denote particular laboratories or dates.

The principal reasons for this viewpoint with respect to the physical quantities are that:

- until now, temperature being one of the very few exceptions, it has not been necessary to introduce explicitly the concept of a system of conventional physical quantities differing from the traditional quantities,
- it would be difficult to make such a concept widely understood and accepted,
- the concept, if introduced for electromotive force and electrical resistance, would propagate to other quantities.

The principal reasons for this viewpoint with respect to the units are that:

- the appearance of creating a unit system other than SI should be avoided, particularly as this would propagate to units for other quantities,

– the new reference standards will be completely satisfactory representations of the volt and the ohm for the great majority of applications,

– any disagreement between those laboratories that realize the new reference standards will be negligible from the point of view of the great majority of users,

– many countries are in any case constrained by their existing legislation concerning physical quantities and units to use the SI names and symbols.

1.3. Concerning the practical implementation of the Recommendations 1 (CI-1988) and 2 (CI-1988)

The CCE having carefully considered the three approaches listed in the reports of the Working Groups, documents CCE/88-34 and CCE/88-35², is of the opinion that a rigorous solution to this problem has been identified which avoids

- (i) defining new units “V₉₀” or “Ω₉₀”,
- (ii) defining new physical quantities “E₉₀” or “R₉₀”,
- (iii) the use of subscripts or other distinguishing symbols of any sort on either unit symbols or quantity symbols.

The preferred approach is indicated in the following example of a statement that may be communicated to users of standard-cell calibration certificates:

The measured emf, E , or electric potential difference, U , of the unknown source may be rigorously expressed in terms of the SI volt, V , as:

$$E = (1.018 \text{ xxx xx}) V \pm \varepsilon$$

The symbol ε represents the total uncertainty, at the level of one standard deviation, and is given by

$$\varepsilon = [(\Delta E)^2 + (E \cdot \delta)^2]^{1/2}$$

where ΔE is the combined uncertainty in volts (at one standard deviation) associated with the calibration itself and with the realization of the Josephson-effect reference standard at the particular national standards laboratory, and δ represents the relative uncertainty with which the ratio K_{J-90}/K_J is known. At present δ is estimated to be 4×10^{-7} (one standard deviation) according to Recommendation 1 (CI-1988).

Since, by international agreement, δ is common to all laboratories, it may be indicated separately and the above expression for E may be rewritten

$$E = (1.018 \text{ xxx xx}) V \pm \Delta E$$

for all practical purposes of precision electrical metrology and trade. However, when this is done, δ should

² Note to reader: these two Documents dealt with the Josephson effect and the quantum Hall effect, respectively.

appear separately on the certificate where the precision is such as to require it. When $\Delta E/E$ is significantly greater than 4×10^{-7} , δ may be omitted.

The treatment of resistance measurements [Recommendation 2 (CI-1988)] is strictly analogous.

1.4. Example of the wording to be used on calibration certificates

The values of emf below are based on ... [a description of the calibration procedure may be placed here] ... using the new conventional value of the Josephson constant internationally adopted for use from 1st January 1990 (see Note A).

cell number	emf in volts	uncertainty in volts
1	1.018 123 4	ΔE

[other data related to the calibration may be placed here]

Note A

The value of the Josephson constant used in this calibration is $K_{J-90} = 483\,597.9 \text{ GHz/V}$ and is that adopted, by international agreement, for implementation on 1st January 1990 by all national standards laboratories that use the Josephson effect as a reference standard of the volt. By international agreement, all such laboratories now use the same value of the Josephson constant whereas until recently they did not. National standards laboratories of those countries that do not use the Josephson effect as a reference standard can maintain their own reference standards so as to be consistent with the above value of the Josephson constant, by periodic comparisons with a laboratory that does use the Josephson effect. An ideal reference standard of emf based on the Josephson effect and K_{J-90} is consistent with the SI volt within an assigned fractional one-standard-deviation uncertainty of 4×10^{-7} ($0.4 \mu\text{V}$ for an emf of one volt). Because this uncertainty is the same for all national standards laboratories, it has not been formally included in the uncertainties given in the table. However, its existence must be recognized when the utmost consistency between electrical and mechanical measurement is required.

Comité Consultatif pour la Masse et les grandeurs apparentées

3rd Meeting

The Comité Consultatif pour la Masse et les grandeurs apparentées (CCM) met at the Pavillon de Breteuil on the 26th and 27th of May 1988. The President, Prof. Bray, being indisposed the meeting was chaired by Dr. Giacomo, Director of the BIPM. The CCM covers a wide range of activities in the fields of mass,

force and pressure standards and much of the meeting was devoted to the examination of reports drawn up by the nine Working Groups. Most of these Working Groups had met in the days immediately preceding the meeting of the CCM. The fields of work covered by the Working Groups were: 1, the measurement of air density; 2, the conservation and behaviour of Pt/Ir mass standards; 3, the conservation and behaviour of stainless-steel mass standards; 4, the measurement of the density of liquids and solids; 5, force measurement; 6, 7, 8 and 9, the measurement of high, medium, low and very low pressures, respectively.

In many of these fields, in addition to the individual and collaborative projects under way, international comparisons had taken place or were in progress and reports were presented. The CCM also discussed recent advances in high-accuracy weighing and balance design and the third verification of national prototypes of the kilogram now in its preliminary stages at the BIPM. It is expected that the first part of this operation, the comparison of the international prototype with its copies at the BIPM, will have been completed by the end of 1988. Over the next three years or so, national prototypes will come to the BIPM in groups for verification. Since the last time such a large scale verification took place, some forty years ago, the accuracy of the best balances has improved by at least a factor of ten. The present verification is being carried out using the NBS-2 balance which is a single-pan, knife-edge balance that has an accuracy of about 1 μg in the comparison of Pt/Ir mass standards, i. e. a relative uncertainty at the level of one standard deviation of about 1 part in 10^9 .

Comité Consultatif pour les Etalons de Mesure des Rayonnements Ionisants

Section I (X-rays, γ -rays and electrons) and Section III (Neutrons) of the Comité Consultatif pour les Etalons de Mesure de Rayonnements Ionisants (CCEMRI) met from 8th to 11th and 18th to 20th of April respectively. During the meeting of Section I, the work of the BIPM was reviewed and the results of recent comparisons of national standards were discussed. The need for comparisons of absorbed-dose standards for radiation of energy above 1 MeV was stressed. Two Recommendations were adopted and sent to the CCEMRI for approval at its next meeting. At the meeting of Section III, the BIPM work on neutron measurements was reviewed. The published results of completed neutron-emission-rate and fluence-rate comparisons, the NPL neutron-dosimetry comparison and the preliminary report on the BIPM neutron-dosimetry comparison were all discussed.

Work in the BIPM Laboratories

Among the principal activities in the laboratories of the BIPM over the past year have been the following:

– Electricity section: a limited comparison of 1 Ω national reference standards of resistance was carried out to check the consistency among the various realizations of the quantum Hall effect now being made in 11 national laboratories and the BIPM. Expressed in terms of the BIPM's representation of the ohm, Ω_{69-BI} , on the central date of the comparison, the measured results for the quantized Hall resistance in five of the six laboratories claiming uncertainties of 4 parts in 10^8 or less are within a range of 7 parts in 10^8 . The overall spread of all results was 6 parts in 10^7 . Refinements in the BIPM quantum-Hall-effect system, based upon a cryogenic current comparator, now allow Ω_{69-BI} to be monitored with an uncertainty of 1.5 parts in 10^8 .

Using Josephson junctions made from the new high- T_c superconducting material a measurement of $2e/h$ was made having an uncertainty of 3 parts in 10^6 and which differed from the value obtained from a metallic Josephson junction by about 5 parts in 10^6 .

– Mass section: as already mentioned, work began on the third international verification of national prototypes of the kilogram. The BIPM flexure-strip balance has been used to carry out an experiment to search for a nuclear-isospin-coupled "fifth-force". No evidence for the existence of such a force was found, but during the experiment weighings of 2.3 kg masses were carried out that showed remarkably small standard deviations of about 5 parts in 10^{12} .

– Time section: as part of the regular analysis of clock comparisons made using the GPS satellites which go to make up International Atomic Time (TAI) and Universal Coordinated Time (UTC), it was found that for laboratories within about 1000 km of each other errors in coordinates could be discerned and corrected for with an accuracy of about 15 cm in the geocentric coordinates x , y and z . As a result, time comparisons between these (European) laboratories can now be made to within a few nanoseconds.

– Laser section: important international comparisons of laser wavelengths and frequencies have been carried out between a total of 8 countries, mostly at wavelengths in the visible ($\lambda = 633 \text{ nm}$) but also one in the infrared ($\lambda = 3.39 \mu\text{m}$). Uncertainties in these comparisons are at level of about 1 part in 10^{11} and differences between lasers from participating countries were found, in many cases, to be hardly greater than this.

- Ionizing radiations section: participation in the international comparison of the measurements of activity of iodine-125 has begun. Two methods of spectrum analysis are being used in order to understand better the results obtained earlier during a limited comparison of measurement of activity of the same nuclide. The long-term work on counting methods and counting statistics continues with much emphasis now being placed on the method of 'generalized dead times'.

- Radiometry: new work has begun in radiometry. Equipment has been built and is now in operation for the comparison of calibrations of silicon diodes and thermopiles. The method of self-calibration of silicon diodes has been used and experience is being gained so that international comparisons and, in due course, calibrations can be carried out at the BIPM.

Other News

During the meeting of the CIPM in October 1988 a new building (of some 900 m² in surface) was inaugurated. It will house a library and offices for scientific staff, the secretariat and the Director. This completes the second stage of a long-term plan for buildings at the BIPM, the first stage of which was a new laboratory building for laser work opened in 1984.

On 31st July 1988 Dr. P. Giacomo, who had been Director of the BIPM since 1978, retired and was succeeded by Dr. T.J. Quinn, previously Deputy Director.

Publications

Since October 1987 the BIPM has published:

18^e Conférence Générale des Poids et Mesures (1987), Comptes Rendus, 108 pages.

Procès-verbaux des séances du Comité International des Poids et Mesures, tome 55 (76^e session, octobre 1987), 178 pages.

Comité Consultatif de Photométrie et Radiométrie, 11^e session (1986), 183 pages.

Comité Consultatif de Thermométrie, 16^e session (1987), 162 pages.

Rapport Annuel du BIH pour 1987 (about 72 pages covering the contribution of the BIPM on time scales).

Circulaire D du BIH (monthly) (contribution of the BIPM on time scales).

Circulaire T (monthly), circular of the BIPM taking over the part "Temps" of the circular D of the BIH (Circular T1 for January 1988 was published on March 1st, 1988).

Le BIPM et la Convention du Mètre, illustrated brochure in French and in English, 47 pages, widely circulated through various national laboratories.

One should also mention some 40 articles published by staff members in scientific journals and a dozen BIPM reports; the complete list of these publications may be found in the Procès-Verbaux du CIPM, 77th meeting (1988), which will appear in 1989.

Copies of these documents may be obtained upon application to: Mr le Directeur du BIPM, Pavillon de Breteuil, F-92312 Sèvres Cedex, or from the Librairie Offilib, 48 rue Gay-Lussac, F-75240 Paris Cedex 05.

6.1.3 Three recommendations were adopted by the CCT at its 17th Session [14]. These recommendations were considered by the CIPM and Recommendation T1 (1989) of the CCT was adopted as Recommendation 5 (CI-89) of the CIPM. Recommendations T2 (1989) and T3 (1989) of the CCT were noted by the CIPM as CCT recommendations. The CCT recommendations were as follows:

6.1.3.1 *Recommendation T1 (1989)*

The International Temperature Scale of 1990

The Comité Consultatif de Thermométrie (CCT) acting in accordance with Resolution 7 of the 18^e CGPM has generated the International Temperature Scale of 1990 (ITS-90) in order to supersede the International Practical Temperature Scale of 1968 (IPTS-68).

The CCT notes that, by comparison with the IPTS-68, the ITS-90

- extends to lower temperatures, down to 0.65 K, and hence also supersedes the EPT-76,
- is in substantially better agreement with corresponding thermodynamic temperatures,
- has much improved continuity, precision and reproducibility throughout its range and
- has subranges and alternative definitions in certain ranges which greatly facilitate its use.

The CCT also notes that, to accompany the text of the ITS-90 there will be two further documents, the Supplementary Information for the ITS-90 and Techniques for Approximating the ITS-90. These documents will be published by the BIPM and periodically updated.

The CCT recommends

- that on 1 January 1990 the ITS-90 come into force and
- that from this same date the IPTS-68 and the EPT-76 be abrogated.

6.1.3.2 Recommendation T2 (1989)

Reference tables for thermocouples and industrial platinum resistance thermometers

The Comité Consultatif de Thermométrie,
considering

- that the introduction of the International Temperature Scale of 1990 (ITS-90) will lead to an urgent requirement for new reference tables for both thermocouples and industrial platinum resistance thermometers,

requests its Working Group 2

- to collaborate with national laboratories in the rapid preparation of new reference tables taking into account not only the change from IPTS-68 to ITS-90 but also new information on the behavior of thermocouples and industrial platinum resistance thermometers,

recommends

that these new tables be used as the basis for new national and international reference tables for thermocouples and industrial platinum resistance thermometers and

that meanwhile the existing reference tables based upon IPTS-68 should be used in conjunction with the table of differences $T_{90} - T_{68}$ which appears in the ITS-90.

6.1.3.3 Recommendation T3 (1989)

The uncertainty inherent in the realization of the International Temperature Scale of 1990

The Comité Consultatif de Thermométrie,

considering the requirement for assigning an uncertainty to the numerical value of any temperature on the International Temperature Scale of 1990 (ITS-90),

encourages national laboratories to

a) quantify the uncertainties in the fixed point realizations,
b) quantify the uncertainties resulting from the use of the specified interpolating instruments of ITS-90,

c) develop the mathematical procedures describing the propagation of these uncertainties to any intermediate temperature.

6.1.4 Reproduction of article by B. W. Mangum, entitled "Special Report on the International Temperature Scale of 1990; Report on the 17th Session of the Consultative Committee on Thermometry," and published in J. Res. Natl. Inst. Stand. Technol. **95**, 69-77 (1990).

Special Report on the International Temperature Scale of 1990

*Report on the 17th Session of the
Consultative Committee on Thermometry*

Volume 95

Number 1

January-February 1990

B. W. Mangum

National Institute of Standards
and Technology,
Gaithersburg, MD 20899

This article summarizes the results of the 17th Session of the Consultative Committee on Thermometry of the International Committee of Weights and Measures (Comité Consultatif de Thermométrie of the Comité International des Poids et Mesures) that met in Sèvres, France, September 12-14, 1989. That session was devoted exclusively to the completion of the International Temperature Scale of 1990, described

herein, and to the implications of its adoption.

Key words: CCT; Comité Consultatif de Thermométrie; Consultative Committee on Thermometry; International Temperature Scale of 1990; temperature; temperature scale; thermodynamic temperature; thermometry.

Accepted: November 4, 1989

1. Introduction

The Consultative Committee on Thermometry (Comité Consultatif de Thermométrie, CCT) is one of eight Consultative Committees (Comités Consultatifs) of the International Committee of Weights and Measures (Comité International des Poids et Mesures, CIPM). The CIPM is a committee of the General Conference of Weights and Measures (Conférence Générale des Poids et Mesures, CGPM). The eight Consultative Committees (Comités Consultatifs) of the CIPM are:

1. The Comité Consultatif d'Électricité (CCE), established in 1927,
2. The Comité Consultatif de Photométrie et Radiométrie (CCPR), assigned this name in 1971; the previous name was the Comité Consultatif de Photométrie, established in 1933,
3. The Comité Consultatif de Thermométrie (CCT), established in 1937,
4. The Comité Consultatif pour la Définition du Mètre (CCDM), established in 1952,

5. The Comité Consultatif pour la Définition de la Seconde (CCDS), established in 1956,

6. The Comité Consultatif pour les Étalons de Mesure des Rayonnements Ionisants (CCEMRI), established in 1958,

7. The Comité Consultatif des Unités (CCU), established in 1964, and

8. The Comité Consultatif pour la Masse et les grandeurs apparentées (CCM), established in 1980.

The CCT is composed presently of members from the following laboratories:

1. Amt für Standardisierung, Messwesen und Warenprüfung [ASMW], Berlin, DDR,
2. Bureau National de Métrologie, Paris, France: Institut National de Métrologie, [INM] du Conservatoire National des Arts et Métiers,
3. Ceskoslovensky Metrologicky Ustav [CSMU], Bratislava, Czechoslovakia,
4. National Research Council [NRC], Ottawa, Canada,

5. CSIRO, Division of Applied Physics [CSIRO], Lindfield, Australia,

6. D. I. Mendeleev Institute for Metrology [VNIIM], Leningrad, USSR; Physico-Technical and Radio-Technical Measurements Institute (PRMI), Moscow, USSR,

7. National Institute of Metrology [NIM], Beijing, PRC,

8. Istituto di Metrologia G. Colonnetti [IMGC], Turin, Italy

9. Kamerlingh Onnes Laboratorium [KOL], Leiden, The Netherlands,

10. Korea Standards Research Institute [KSRI], Seoul, Korea,

11. National Institute of Standards and Technology [NIST], Gaithersburg, MD, USA

12. National Physical Laboratory [NPL], Teddington, UK,

13. National Research Laboratory of Metrology [NRLM], Ibaraki, Japan,

14. Physikalisch-Technische Bundesanstalt [PTB], Braunschweig, FRG,

15. Van Swinden Laboratorium [VSL], Delft, The Netherlands,

16. Iowa State University, Ames, Iowa, USA, and

17. Bureau International des Poids et Mesures [BIPM], Sèvres, France.

The CCT met September 12-14, 1989 at the Bureau International des Poids et Mesures (BIPM) in its 17th Session [1] and completed the final details of the new temperature scale, the International Temperature Scale of 1990 (ITS-90) [2]. The CCT then recommended to the CIPM at its meeting on September 26-28, 1989 at the BIPM that the ITS-90 be adopted and made the official scale. The CIPM did adopt the new temperature scale at their meeting [3] and the ITS-90 became the official international temperature scale on January 1, 1990, the same date on which changes affecting certain electrical reference standards were implemented [4]. The ITS-90 supersedes the International Practical Temperature Scale of 1968, Amended Edition of 1975 [IPTS-68(75)] [5] and the 1976 Provisional 0.5 K to 30 K Temperature Scale (EPT-76) [6].

The CCT undertook the development of the ITS-90 because of the deficiencies and limitations of the IPTS-68(75) and completed the scale in accordance with Resolution 7 of the 18th Conférence Générale des Poids et Mesures [7], which met in October 1987. The deficiencies and limitations of the IPTS-68(75) included its lower limit of 13.81 K, its inaccuracy relative to thermodynamic temperatures, and its non-uniqueness and irreproducibility,

especially in the temperature region from $T_{68}=903.89$ K ($t_{68}=630.74$ °C) to $T_{68}=1337.58$ K ($t_{68}=1064.43$ °C), the region in which the Pt-10%Rh/Pt thermocouple was the standard interpolating instrument.

The ITS-90 extends upward from 0.65 K and temperatures on this scale are in much better agreement with thermodynamic values than are those on the IPTS-68(75) and the EPT-76. The new scale has subranges and alternative definitions in certain ranges that greatly facilitate its use. Furthermore, its continuity, precision, and reproducibility throughout its range are much improved over the corresponding characteristics of the previous scales. The replacement of the thermocouple with the platinum resistance thermometer at temperatures in the range from 630.74 to 961.93 °C of the IPTS-68(75) resulted in the biggest improvement in reproducibility. Also, improvements in radiometric techniques have allowed using the silver freezing point as the reference point for radiation thermometry. This is a lower temperature reference point than was used in the IPTS-68(75).

The change in the temperature scale affects not only technical interests involved directly in thermometry but also those involved with other reference standards, such as electrical standards, if those standards are sensitive to temperature. As examples, standard resistors and standard cells are sensitive to temperature and generally are maintained in constant-temperature environments, at least in national standards laboratories. At the present time, the temperatures of those environments are normally determined with thermometers that have been calibrated on the IPTS-68(75). A given thermodynamic temperature expressed on the ITS-90, however, has a value that is different from that expressed on the IPTS-68(75), as indicated [2,8] in figure 1. A table of differences between temperatures on the ITS-90, T_{90} or t_{90} , and those on the IPTS-68(75), T_{68} or t_{68} , and those on the EPT-76, T_{76} , is given in the text of the ITS-90. Since temperature values expressed on these scales are different, if the temperature of the environment of a reference standard is adjusted so that *its value when expressed on the ITS-90 has the same value* as had been used on the IPTS-68(75), there will have been a *change* of the thermodynamic temperature and the value of the reference standard will usually change. Of course, one may not want to change the thermodynamic temperature of the reference standard. In that case, the thermodynamic temperature, as expressed on the IPTS-68(75), can simply be expressed on the ITS-90 (a numerical value different

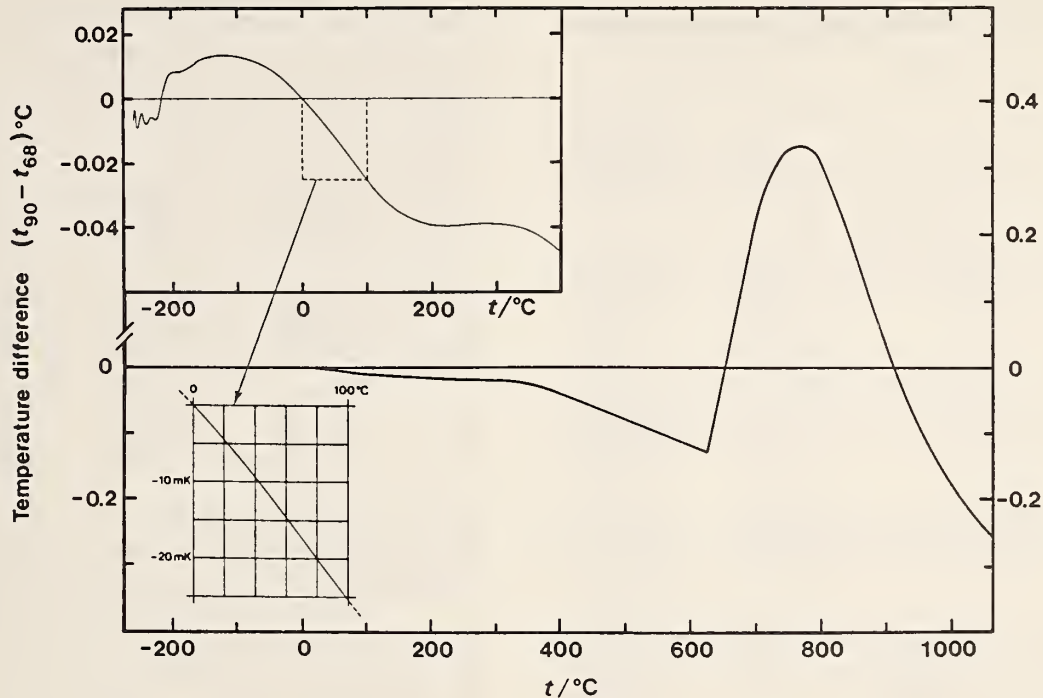

Figure 1. Differences between t_{90} and t_{68} as a function of t_{90} (expressed as t).

from that on the IPTS-68(75)) and the reference standards will be unaffected. For more details on the effects of the change of the temperature scale on electrical standards, see National Institute of Standards and Technology (NIST) Technical Note 1263 [4].

In addition to the effect on reference standards for measurements, all temperature-sensitive properties that are presently expressed on the IPTS-68(75) may be affected and may require changes in values.

For details on realizations and approximations of the ITS-90, see NIST Technical Note 1265 [9].

2. CCT's 17th Session Principal Decisions

2.1 Definition of the ITS-90

The ITS-90 was designed by the CCT in such a manner that temperature values obtained on it do not deviate from the Kelvin thermodynamic temperature values by more than the uncertainties of the latter values at the time the ITS-90 was adopted. Thermodynamic temperature is indicated by the symbol T and has the unit known as the kelvin, symbol K. The size of the kelvin is defined to be $1/273.16$ of the thermodynamic temperature of the triple point of water.

Temperatures on the ITS-90 can be expressed in terms of the International Kelvin Temperatures, with the symbol T_{90} , or in terms of the International Celsius Temperatures, with the symbol t_{90} . The unit of the temperature T_{90} is the kelvin, symbol K, and the unit of the temperature t_{90} is the degree Celsius, symbol °C. The relation between T_{90} and t_{90} is:

$$t_{90}/^{\circ}\text{C} = T_{90}/\text{K} - 273.15. \quad (1)$$

The ITS-90 has alternative definitions of T_{90} in certain temperature ranges and they have equal status. In measurements of the highest precision made at the same temperature, the alternative definitions may yield detectably different temperature values. Also, at any given temperature between defining fixed points, different interpolating thermometers that meet the specifications of the ITS-90 may indicate different temperature values. The magnitude of the differences resulting from these two sources, however, is sufficiently small to be negligible for all practical purposes.

Temperatures on the ITS-90 are defined in terms of equilibrium states of pure substances (defining fixed points), interpolating instruments, and equations that relate the measured property to T_{90} . The defining equilibrium states of the pure substances and the assigned temperatures are listed in table 1.

Table 1. Defining fixed points of the ITS-90

Material ^a	Equilibrium state ^b	Temperature	
		T_{90} (K)	t_{90} (°C)
³ He and ⁴ He	VP	3 to 5	−270.15 to −268.15
e-H ₂	TP	13.8033	−259.3467
e-H ₂ (or He)	VP (or CVGT)	≈ 17	≈ −256.15
e-H ₂ (or He)	VP (or CVGT)	≈ 20.3	≈ −252.85
Ne ^c	TP	24.5561	−248.5939
O ₂	TP	54.3584	−218.7916
Ar	TP	83.8058	−189.3442
Hg ^c	TP	234.3156	−38.8344
H ₂ O	TP	273.16	0.01
Ga ^c	MP	302.9146	29.7646
In ^c	FP	429.7485	156.5985
Sn	FP	505.078	231.928
Zn	FP	692.677	419.527
Al ^c	FP	933.473	660.323
Ag	FP	1234.93	961.78
Au	FP	1337.33	1064.18
Cu ^c	FP	1357.77	1084.62

^a e-H₂ indicates equilibrium hydrogen, that is, hydrogen with the equilibrium distribution of its ortho and para states. Normal hydrogen at room temperature contains 25% para hydrogen and 75% ortho hydrogen.

^b VP indicates vapor pressure point; CVGT indicates constant volume gas thermometer point; TP indicates triple point (equilibrium temperature at which the solid, liquid and vapor phases coexist); FP indicates freezing point and MP indicates melting point (the FP and the MP are equilibrium temperatures at which the solid and liquid phases coexist under a pressure of 101 325 Pa, one standard atmosphere). The isotopic composition is that naturally occurring.

^c Previously, these were secondary fixed points.

2.1.1 Temperature Range From 0.65 to 5.0 K

Between 0.65 and 3.2 K, the ITS-90 is defined by the vapor pressure-temperature relation of ³He, and between 1.25 and 2.1768 K (the λ point) and between 2.1768 and 5.0 K by the vapor pressure-temperature relations of ⁴He. T_{90} is defined by the vapor pressure equations of the form:

$$T_{90}/\text{K} = A_0 + \sum_{i=1}^9 A_i [(\ln(p/\text{Pa}) - B)/C]^i, \quad (2)$$

with the values of the coefficients A_i , and of the constants A_0 , B , and C of the equations being specified, and given in table 2.

2.1.2 Temperature Range From 3.0 to 24.5561 K

Between 3.0 and 24.5561 K, the ITS-90 is defined in terms of the ³He or ⁴He constant volume gas thermometer (CVGT). The thermometer is calibrated at three temperatures—at the triple point of neon (24.5561 K), at the triple point of equilibrium hydrogen (see footnote a in table 1) (13.8033 K), and at a temperature between 3.0 and 5.0 K, the

Table 2. Values of the coefficients A_i , and of the constants A_0 , B , and C for the ³He and ⁴He vapor pressure equations and the temperature range for which each equation is valid

Coef. or constant	³ He	⁴ He	⁴ He
	0.65 to 3.2 K	1.25 to 2.1768 K	2.1768 to 5.0 K
A_0	1.053 447	1.392 408	3.146 631
A_1	0.980 106	0.527 153	1.357 655
A_2	0.676 380	0.166 756	0.413 923
A_3	0.372 692	0.050 988	0.091 159
A_4	0.151 656	0.026 514	0.016 349
A_5	−0.002 263	0.001 975	0.001 826
A_6	0.006 596	−0.017 976	−0.004 325
A_7	0.088 966	0.005 409	−0.004 973
A_8	−0.004 770	0.013 259	0
A_9	−0.054 943	0	0
B	7.3	5.6	10.3
C	4.3	2.9	1.9

value of which is determined by using either ³He or ⁴He vapor pressure thermometry.

For a ⁴He CVGT used between 4.2 K and the triple point of neon (24.5561 K), T_{90} is defined by the equation:

$$T_{90} = a + bp + cp^2, \quad (3)$$

where p is the CVGT pressure and a , b , and c are coefficients that are determined by calibration at the three specified temperatures, but with the additional requirement that the calibration with the vapor pressure thermometer be made at a temperature between 4.2 and 5.0 K.

For a ⁴He CVGT used between 3.0 and 4.2 K, and for a ³He CVGT used from 3.0 to 24.5561 K, the non-ideality of the gas must be taken into account, using the appropriate second virial coefficient, $B_3(T_{90})$ or $B_4(T_{90})$. T_{90} is defined in this range by the equation:

$$T_{90} = \frac{a + bp + cp^2}{1 + B_x(T_{90})N/V}, \quad (4)$$

where p is the CVGT pressure; a , b , and c are coefficients that are determined from calibration at the three defining temperatures; $B_x(T_{90})$ refers to $B_3(T_{90})$ or $B_4(T_{90})$; and N/V is the gas density in moles per cubic meter in the CVGT bulb. The values of the second virial coefficients at any given temperature are to be calculated according to equations specified in the official document of the ITS-90 (and also in the NIST Technical Note 1265 [9]).

2.1.3 Temperature Range From 13.8033 to 1234.93 K Between 13.8033 K ($-259.3467\text{ }^\circ\text{C}$) and 1234.93 K ($961.78\text{ }^\circ\text{C}$), the ITS-90 is defined in terms of the specified fixed points given in table 1, by resistance ratios of platinum resistance thermometers (PRTs) obtained by calibration at specified sets of the fixed points, and by reference functions and deviation functions of resistance ratios which relate to T_{90} between the fixed points.

Temperatures on the ITS-90 are expressed in terms of the ratio $W(T_{90})$ of the resistance $R(T_{90})$ at temperature T_{90} and the resistance $R(273.16\text{ K})$ at the triple point of water, i.e.,

$$W(T_{90}) = R(T_{90})/R(273.16\text{ K}). \quad (5)$$

For a PRT to be an acceptable instrument of the ITS-90, its coil must be made from pure platinum and be strain-free. Additionally, the finished PRT must meet one of the following criteria:

$$W(302.9146\text{ K}) \geq 1.118\ 07 \quad (6)$$

$$W(234.3156\text{ K}) \leq 0.844\ 235. \quad (7)$$

An acceptable PRT that is to be used to the freezing point of silver must meet the following requirement also:

$$W(1234.93\text{ K}) \geq 4.2844. \quad (8)$$

The temperature T_{90} is calculated from the resistance ratio relation:

$$W(T_{90}) - W_r(T_{90}) = \Delta W(T_{90}), \quad (9)$$

where $W(T_{90})$ is the observed value, $W_r(T_{90})$ is the value calculated from the reference function, and $\Delta W(T_{90})$ is the deviation of the observed $W(T_{90})$ value of the particular PRT from the reference function value at T_{90} .

There are two reference functions $W_r(T_{90})$, one for the range 13.8033 to 273.16 K and the second for the range 273.15 to 1234.93 K. The deviation $\Delta W(T_{90})$ is obtained as a function of T_{90} for various ranges by calibration at specified fixed points. The form of the deviation function depends upon the temperature range of calibration.

2.1.4 Temperature Subrange From 13.8033 to 273.16 K In the range 13.8033 to 273.16 K, the equation for the reference function $W_r(T_{90})$ as a function of T_{90} is given by:

$$\ln[W_r(T_{90})] = A_0 + \sum_{i=1}^{12} A_i \{[\ln(T_{90}/273.16\text{ K}) + 1.5]/1.5\}^i. \quad (10)$$

The specified inverse of this equation, equivalent to within $\pm 0.000\ 1\text{ K}$, is:

$$T_{90}/273.16\text{ K} = B_0 + \sum_{i=1}^{15} B_i \left(\frac{[W_r(T_{90})]^{1/6} - 0.65}{0.35} \right)^i. \quad (11)$$

The values of the constants A_0 and B_0 and values of the coefficients A_i and B_i of the two equations are listed in table 3.

Table 3. Values of the coefficients A_i , B_i , C_i , and D_i and of the constants A_0 , B_0 , C_0 , and D_0 in the reference functions, eqs (10) and (18), and in the inverse functions approximating them, given by eqs (11) and (19)

Constant or coefficient	Value	Constant or coefficient	Value
A_0	-2.135 347 29	B_0	0.183 324 722
A_1	3.183 247 20	B_1	0.240 975 303
A_2	-1.801 435 97	B_2	0.209 108 771
A_3	0.717 272 04	B_3	0.190 439 972
A_4	0.503 440 27	B_4	0.142 648 498
A_5	-0.618 993 95	B_5	0.077 993 465
A_6	-0.053 323 22	B_6	0.012 475 611
A_7	0.280 213 62	B_7	-0.032 267 127
A_8	0.107 152 24	B_8	-0.075 291 522
A_9	-0.293 028 65	B_9	-0.056 470 670
A_{10}	0.044 598 72	B_{10}	0.076 201 285
A_{11}	0.118 686 32	B_{11}	0.123 893 204
A_{12}	-0.052 481 34	B_{12}	-0.029 201 193
		B_{13}	-0.091 173 542
		B_{14}	0.001 317 696
		B_{15}	0.026 025 526
C_0	2.781 572 54	D_0	439.932 854
C_1	1.646 509 16	D_1	472.418 020
C_2	-0.137 143 90	D_2	37.684 494
C_3	-0.006 497 67	D_3	7.472 018
C_4	-0.002 344 44	D_4	2.920 828
C_5	0.005 118 68	D_5	0.005 184
C_6	0.001 879 82	D_6	-0.963 864
C_7	-0.002 044 72	D_7	-0.188 732
C_8	-0.000 461 22	D_8	0.191 203
C_9	0.000 457 24	D_9	0.049 025

If the PRT is to be used throughout the range from 13.8033 to 273.16 K, it must be calibrated at the triple points of equilibrium hydrogen (13.8033 K), neon (24.5561 K), oxygen (54.3584 K), argon (83.8058 K), mercury (234.3156 K), and water (273.16 K) and at two additional temperatures very close to 17.0 and 20.3 K. The temperatures of calibration at 17.0 and 20.3 K may be determined by using either a CVGT or the vapor pressure-temperature relation of equilibrium hydrogen. When the CVGT is used, the two temperatures must be within the ranges 16.9 to 17.1 K and 20.2 to 20.4 K, respectively. When the equilibrium hydrogen vapor pressure thermometer is used, the two temperatures must be within the ranges 17.025 to 17.045 K and 20.26 to 20.28 K, respectively. The temperatures of the equilibrium hydrogen vapor pressure thermometer are determined from the values of the hydrogen vapor pressure, p , and the equations:

$$T_{90}/\text{K} - 17.035 = (p/\text{kPa} - 33.3213)/13.32 \quad (12)$$

$$T_{90}/\text{K} - 20.27 = (p/\text{kPa} - 101.292)/30. \quad (13)$$

Depending upon the temperature range of application, PRTs may be calibrated from 273.16 K down to 13.8033 K (triple point of equilibrium hydrogen), down to 24.5561 K (triple point of neon), down to 54.3584 K (triple point of oxygen), or down to 83.8058 K (triple point of argon).

The deviation function for calibration in the range 13.8033 to 273.16 K is given by the relation:

$$\Delta W_1(T_{90}) = W(T_{90}) - W_r(T_{90}) = a_1[W(T_{90}) - 1] + b_1[W(T_{90}) - 1]^2 + \sum_{i=1}^5 c_i [\ln W(T_{90})]^{i+n}, \quad (14)$$

with $n = 2$. The coefficients a_1 , b_1 , and the five c_i 's of the deviation function are obtained by calibration at all of the above eight temperatures, including that at the triple point of water. The values of $W_r(T_{90})$ are obtained from the reference function for this range. Although the official text of the ITS-90 does not assign subscripts to the coefficients a and b , nor does it designate the deviation equations by the symbols $\Delta W_m(T_{90})$, where in eq (14) $m = 1$, these designations will be used in this paper for clarity and for ease of reference. In any case, some such terminology must be used in PRT calibration reports and this was chosen for convenience.

2.1.5 Subrange From 24.5561 to 273.16 K The deviation function for calibration in this range is

given by the relation:

$$\Delta W_2(T_{90}) = W(T_{90}) - W_r(T_{90}) = a_2[W(T_{90}) - 1] + b_2[W(T_{90}) - 1]^2 + \sum_{i=1}^3 c_i [\ln W(T_{90})]^{i+n}, \quad (15)$$

where the exponent n has the value $n = 0$. The coefficients a_2 , b_2 , and c_i of this deviation function are obtained by calibrating the PRT at the triple points of equilibrium hydrogen (13.8033 K), neon (24.5561 K), oxygen (54.3584 K), argon (83.8058 K), mercury (234.3156 K) and water (273.16 K). The values of $W_r(T_{90})$ are obtained from the reference function.

2.1.6 Subrange From 54.3584 to 273.16 K The deviation function for calibration in this range is given by the relation:

$$\Delta W_3(T_{90}) = a_3[W(T_{90}) - 1] + b_3[W(T_{90}) - 1]^2 + c_1 [\ln W(T_{90})]^{1+n}, \quad (16)$$

where the exponent n has the value $n = 1$. The coefficients a_3 , b_3 , and c_1 of this deviation function are obtained by calibrating the PRT at the triple points of oxygen (54.3584 K), argon (83.8058 K), mercury (234.3156 K), and water (273.16 K). The values of $W_r(T_{90})$ are obtained from the reference function.

2.1.7 Subrange From 83.8058 to 273.16 K The deviation function for calibration in this range is given by the relation:

$$\Delta W_4(T_{90}) = a_4[W(T_{90}) - 1] + b_4[W(T_{90}) - 1] \ln W(T_{90}). \quad (17)$$

The coefficients a_4 and b_4 of this deviation function are obtained by calibrating the PRT at the triple points of argon (83.8058 K), mercury (234.3156 K), and water (273.16 K). The values of $W_r(T_{90})$ are obtained from the reference function.

2.1.8 Temperature Subrange From 273.15 to 1234.93 K In the range 273.15 to 1234.93 K, the equation for the reference function $W_r(T_{90})$ is given by:

$$W_r(T_{90}) = C_0 + \sum_{i=1}^9 C_i \left(\frac{T_{90}/\text{K} - 754.15}{481} \right)^i. \quad (18)$$

The specified inverse of this equation, equivalent to within ± 0.00013 K, is:

$$T_{90}/\text{K} - 273.15 = D_0 + \sum_{i=1}^9 D_i \left(\frac{W_r(T_{90}) - 2.64}{1.64} \right)^i. \quad (19)$$

The values of the constants C_0 and D_0 and of the coefficients C_i and D_i for these equations are listed in table 3.

If the PRT is to be used over this entire subrange (273.15 to 1234.93 K), it must be calibrated at the triple point of water (273.16 K) and at the freezing points of tin (505.078 K), zinc (692.677 K), aluminum (933.473 K), and silver (1234.93 K).

The deviation function is given by the relation:

$$\begin{aligned} \Delta W_6(T_{90}) = W(T_{90}) - W_r(T_{90}) = & a_6[W(T_{90}) - 1] \\ & + b_6[W(T_{90}) - 1]^2 + c_6[W(T_{90}) - 1]^3 \\ & + d[W(T_{90}) - W(933.473 \text{ K})]^2. \end{aligned} \quad (20)$$

The values of the coefficients a_6 , b_6 , and c_6 are determined from the measured deviations $\Delta W(T_{90})$ of $W(T_{90})$ from the reference values $W_r(T_{90})$ at the freezing points of tin (505.078 K), zinc (692.677 K) and aluminum (933.473 K). The coefficient d is determined from these values of the coefficients a_6 , b_6 , and c_6 and the deviation $\Delta W(T_{90})$ of $W(T_{90})$ from the reference value $W_r(T_{90})$ at the freezing point of silver. The coefficient d in this equation is used only for those temperature measurements in the range from the freezing point of aluminum to the freezing point of silver. For temperature measurements below the freezing point of aluminum, $d = 0$.

PRTs may be calibrated for use over the whole range (273.15 to 1234.93 K) or for shorter ranges by calibrations at fixed points between 273.15 K and the upper limit of 933.473 K (freezing point of aluminum, 660.323 °C), of 692.677 K (freezing point of zinc, 419.527 °C), of 505.078 K (freezing point of tin, 231.928 °C), of 429.7485 K (freezing point of indium, 156.5985 °C), or of 302.9146 K (melting point of gallium, 29.7646 °C).

2.1.9 Subrange From 273.15 to 933.473 K For application in this range, the PRT is calibrated at the triple point of water (273.16 K), and at the freezing points of tin (505.078 K), zinc (692.677 K), and aluminum (933.473 K). The deviation function is given by the relation:

$$\begin{aligned} \Delta W_7(T_{90}) = & a_7[W(T_{90}) - 1] + b_7[W(T_{90}) - 1]^2 \\ & + c_7[W(T_{90}) - 1]^3. \end{aligned} \quad (21)$$

The coefficients a_7 , b_7 , and c_7 , identical to a_6 , b_6 , and c_6 , respectively, are determined from the deviations $\Delta W(T_{90})$ of $W(T_{90})$ from the reference values $W_r(T_{90})$ at the freezing points of tin (505.078 K), zinc (692.677 K), and aluminum (933.473 K).

2.1.10 Subrange From 273.15 to 692.677 K

For application in this range, the PRT is calibrated at the triple point of water (273.16 K), and at the freezing points of tin (505.078 K) and zinc (692.677 K). The deviation function is given by the relation:

$$\Delta W_8(T_{90}) = a_8[W(T_{90}) - 1] + b_8[W(T_{90}) - 1]^2. \quad (22)$$

The coefficients a_8 and b_8 are determined from the deviations $\Delta W(T_{90})$ of $W(T_{90})$ from the reference values $W_r(T_{90})$ at the freezing points of tin (505.078 K) and zinc (692.677 K).

2.1.11 Subrange From 273.15 to 505.078 K

For application in this range, the PRT is calibrated at the triple point of water (273.16 K), and at the freezing points of indium (429.7485 K) and tin (505.078 K). The form of the deviation function is the same as that for the subrange 273.15 to 692.677 K, i.e.,

$$\Delta W_9(T_{90}) = a_9[W(T_{90}) - 1] + b_9[W(T_{90}) - 1]^2. \quad (23)$$

The coefficients a_9 and b_9 are determined from the deviations $\Delta W(T_{90})$ of $W(T_{90})$ from the reference values $W_r(T_{90})$ at the freezing points of indium (429.7485 K) and tin (505.078 K).

2.1.12 Subrange From 273.15 to 429.7485 K

For application in this range, the PRT is calibrated at the triple point of water (273.16 K) and at the freezing point of indium (429.7485 K). The deviation function is:

$$\Delta W_{10}(T_{90}) = a_{10}[W(T_{90}) - 1]. \quad (24)$$

The coefficient a_{10} is determined from the deviation $\Delta W(T_{90})$ of $W(T_{90})$ from the reference value $W_r(T_{90})$ at the freezing point of indium (429.7485 K).

2.1.13 Subrange From 273.15 to 302.9146 K

For application in this range, the PRT is calibrated at the triple point of water (273.16 K) and at the melting point of gallium (302.9146 K). The deviation function is:

$$\Delta W_{11}(T_{90}) = a_{11}[W(T_{90}) - 1]. \quad (25)$$

The coefficient a_{11} is determined from the deviation $\Delta W(T_{90})$ of $W(T_{90})$ from the reference value $W_r(T_{90})$ at the melting point of gallium (302.9146 K).

2.1.14 Subrange From 234.3156 to 302.9146 K

For application in this range, the PRT is calibrated at the triple points of mercury (234.3156 K) and water (273.16 K), and at the melting point of gal-

lium (302.9146 K). The form of the deviation function is the same as that for the subrange 273.15 to 692.677 K, i.e.,

$$\Delta W_5(T_{90}) = a_5[W(T_{90}) - 1] + b_5[W(T_{90}) - 1]^2. \quad (26)$$

The coefficients a_5 and b_5 are determined from the deviations $\Delta W(T_{90})$ of $W(T_{90})$ from the reference values $W_r(T_{90})$ at the triple point of mercury (234.3156 K) and at the melting point of gallium (302.9146 K). The reference values $W_r(T_{90})$ must be calculated from the relevant reference function, both reference functions being required to cover this range.

2.1.15 Temperature Range Above 1234.93 K

At temperatures above 1234.93 K, T_{90} is defined by the relation:

$$\frac{L_\lambda(T_{90})}{L_\lambda[T_{90}(X)]} = \frac{\exp[c_2/\lambda T_{90}(X)] - 1}{\exp[c_2/\lambda T_{90}] - 1}, \quad (27)$$

in which $L_\lambda(T_{90})$ and $L_\lambda[T_{90}(X)]$ are the spectral concentrations of the radiance of a blackbody at wavelength λ (in vacuum) at T_{90} and at $T_{90}(X)$, respectively. $T_{90}(X)$ refers to either the silver freezing point [$T_{90}(\text{Ag}) = 1234.93$ K], the gold freezing point [$T_{90}(\text{Au}) = 1337.33$ K] or the copper freezing point [$T_{90}(\text{Cu}) = 1357.77$ K]. $c_2 = 0.014388$ m·K. Although the freezing-point temperature of silver is the junction point of platinum resistance thermometry and radiation thermometry, it is believed that the T_{90} values of the freezing points of silver, gold and copper are sufficiently self-consistent that the use of any one of them as the reference temperature $T_{90}(X)$ will not result in any significant difference in the measured values of T_{90} from what would be obtained if only the silver freezing point were used.

2.2 Recommendations of the CCT

Three recommendations were adopted by the CCT at its 17th Session. These recommendations were considered by the CIPM and Recommendation T1 (1989) of the CCT was adopted as Recommendation 5 (CI-89) of the CIPM. Recommendations T2 (1989) and T3 (1989) of the CCT were noted by the CIPM as CCT recommendations. The CCT recommendations were as follows:

Recommendation T1 (1989)

The International Temperature Scale of 1990

The Comité Consultatif de Thermométrie (CCT) acting in accordance with Resolution 7 of the 18th

CGPM has generated the International Temperature Scale of 1990 (ITS-90) in order to supersede the International Practical Temperature Scale of 1968 (IPTS-68).

The CCT notes that, by comparison with the IPTS-68, the ITS-90

- extends to lower temperatures, down to 0.65 K, and hence also supersedes the EPT-76,
- is in substantially better agreement with corresponding thermodynamic temperatures,
- has much improved continuity, precision, and reproducibility throughout its range and
- has subranges and alternative definitions in certain ranges which greatly facilitate its use.

The CCT also notes that, to accompany the text of the ITS-90 there will be two further documents, the Supplementary Information for the ITS-90 and Techniques for Approximating the ITS-90. These documents will be published by the BIPM and periodically updated.

The CCT recommends

- that on January 1, 1990 the ITS-90 come into force and
- that from this same date the IPTS-68 and the EPT-76 be abrogated.

Recommendation T2 (1989)

Reference Tables for Thermocouples and Industrial Platinum Resistance Thermometers

The Comité Consultatif de Thermométrie, *considering*

—that the introduction of the International Temperature Scale of 1990 (ITS-90) will lead to an urgent requirement for new reference tables for both thermocouples and industrial platinum resistance thermometers,

requests its Working Group 2

—to collaborate with national laboratories in the rapid preparation of new reference tables taking into account not only the change from IPTS-68 to ITS-90 but also new information on the behavior of thermocouples and industrial platinum resistance thermometers,

recommends

—that these new tables be used as the basis for new national and international reference tables for thermocouples and industrial platinum resistance thermometers and

—that meanwhile the existing reference tables based upon IPTS-68 should be used in conjunction with the table of differences $T_{90} - T_{68}$ which appears in the ITS-90.

(Note: the table of differences $T_{90} - T_{68}$ referred to here may be obtained also from NIST from the author of this article).

Recommendation T3 (1989)

The Uncertainty Inherent in the Realization of the International Temperature Scale of 1990

The Comité Consultatif de Thermométrie, *considering* the requirement for assigning an uncertainty to the numerical value of any temperature on the International Temperature Scale of 1990 (ITS-90),

encourages national laboratories to

a) quantify the uncertainties in the fixed point realizations,

b) quantify the uncertainties resulting from the use of the specified interpolating instruments of ITS-90,

c) develop the mathematical procedures describing the propagation of these uncertainties to any intermediate temperature.

3. Conclusion

Although the uncertainties in the values of thermodynamic temperatures above 100 °C used in the definition of the ITS-90 were larger than desired and larger than had been anticipated a few years ago, the agreement of temperatures on the ITS-90 with thermodynamic temperatures is nevertheless a significant improvement over that of previous scales. The replacement of the thermocouple with the platinum resistance thermometer as the standard instrument of the scale at temperatures in the IPTS-68(75) range from 630.74 to 961.93 °C has improved the reproducibility over that of the IPTS-68(75) significantly. Also, advances in radiometric techniques have improved the precision of measurements in radiation thermometry. The precision of the scale, or what has been called the non-uniqueness of the scale, is significantly improved over that of the IPTS-68(75), as is also the scale's continuity. The extension of the scale downward in temperature to 0.65 K and the use of subranges over which thermometers may be calibrated make the ITS-90 more useful and much more flexible than were the previous scales.

About the author: B. W. Mangum, a physicist, is a Group Leader in the Temperature and Pressure Division of the NIST Center for Chemical Technology and is the NIST representative to the Comité Consultatif de Thermométrie.

4. References

- [1] BIPM Com. Cons. Thermométrie 17, 1989, in press.
- [2] The International Temperature Scale of 1990, *Metrologia* 27, 3 (1990).
- [3] Procès-Verbaux des séances du Comité International des Poids et Mesures, (78^e session, octobre 1989), in press.
- [4] Belecki, N. B., Dziuba, R. F., Field, B. F., and Taylor, B. N., Guidelines for Implementing the New Representations of the Volt and Ohm Effective January 1, 1990, NIST Technical Note 1263 (June 1989).
- [5] The International Temperature Scale of 1968, Amended Edition of 1975, *Metrologia* 12, 7 (1976).
- [6] The 1976 Provisional 0.5 K to 30 K Temperature Scale, *Metrologia* 15, 65 (1979).
- [7] Comptes rendus des séances de la dix-huitième Conférence Générale des Poids et Mesures, Resolution 7 (1987).
- [8] Quinn, T. J., *Metrologia* 26, 69 (1989).
- [9] Mangum, B. W., and Furukawa, G. T., Guidelines for Realizing the International Temperature Scale of 1990, NIST Technical Note 1265 (1990), in press.

6.2 In this appendix, excerpts from proceedings of some meetings of the CIPM and of the CGPM that are related to the designation of the size of the kelvin and to the ITS-90 are presented.

6.2.1 The following is an excerpt from Procès-Verbaux des Séances, Deuxième Series, Tome XXIV, pp. 81-82, Session de 1954 du Comité International des Poids et Mesures, published by Gauthier Villars, Editeur-Imprimeur-Libraire, Paris, 1955, concerning the recommendation of the CIPM that the numerical value of 273.16 °K, exactly, be assigned to the triple point of water on the thermodynamic scale.

"Le Comité International des Poids et Mesures recommande que l'on définisse désormais l'échelle thermodynamique au moyen du point triple de l'eau comme point fixe fondamental."

"Il recommande que l'on attribue par définition à la température du point triple de l'eau dans l'échelle thermodynamique la valeur numérique 273,16°K exactement."

6.2.2 The following is an excerpt from Comptes Rendus des Séances, Dixième Conférence Générale des Poids et Mesures, Reunie à Paris en 1954, p.79, published by Gauthier Villars, Editeur-Imprimeur-Libraire, Editeur du Bureau International des Poids et Mesures, Paris, 1955, concerning the definition of the thermodynamic scale of temperature. This entails the assignment of the value 273.16 °K, exactly, to the triple point of water as a fundamental fixed point.

DÉFINITION DE L'ÉCHELLE THERMODYNAMIQUE DE TEMPÉRATURE.

RÉSOLUTION 3

"La Dixième Conférence Générale des Poids et Mesures décide de définir l'échelle thermodynamique de température au moyen du point triple de l'eau comme point fixe fondamental, en lui attribuant la température 273,16 degrés Kelvin, exactement."

6.2.3 The following recommendations of the CCT, concerning the development of the ITS-90 and simplified methods of its realization, that were presented to the CIPM on 9 July 1987 were excerpted from Procès-Verbaux des Séances du Comité International des Poids et Mesures, Procès-Verbaux de la 76^e session - 1987, Tome 55, pp. T7-T8, Édité par le BIPM, Pavillon de Breteuil, F-92312 Sèvres Cedex, France.

9 juillet 1987

Recommandations
du Comité Consultatif de Thermométrie
présentées
au Comité International des Poids et Mesures

Nécessité de travaux fondamentaux en thermométrie

RECOMMANDATION T 1 (1987)

Le Comité Consultatif de Thermométrie,

tout en déclarant que la valeur T_{90} de la température mesurée dans l'Échelle internationale de température de 1990 (EIT-90) sera aussi voisine de la température thermodynamique T que le permettent les connaissances actuelles,

reconnait

— que l'adoption de l'EIT-90 ne signifie en aucune façon que nous ayons maintenant une connaissance définitive de la valeur des températures thermodynamiques,

— que le travail nécessaire pour développer cette connaissance fondamentale par des déterminations directes des températures thermodynamiques est difficile, complexe et de longue haleine,

— qu'il est nécessaire d'anticiper les besoins à venir d'exactitude et de précision croissantes,

propose, en conséquence, de surveiller en permanence l'accord entre T_{90} et T au fur et à mesure des progrès de la science,

insiste sur l'importance de l'étude et de la mise en œuvre de méthodes nouvelles conduisant à des déterminations plus exactes des températures thermodynamiques, dans tout le domaine couvert par l'EIT-90 et aussi vers les très basses températures jusqu'à quelques millikelvins,

et insiste sur l'importance de la poursuite des travaux des laboratoires nationaux dans ce but.

RECOMMANDATION T 2 (1987)

Le Comité Consultatif de Thermométrie,

tout en reconnaissant que sa tâche principale est de veiller à améliorer la mise en pratique et à mettre à jour périodiquement l'Échelle internationale de température, s'est efforcé dans les années récentes de répondre aux demandes des chercheurs, ingénieurs et autres utilisateurs qui ont besoin de bonnes mesures de température plutôt que de mesures de température du niveau le plus élevé,

a noté les travaux récents sur les thermocouples or/platine et palladium/platine indiquant que ces thermocouples peuvent présenter des avantages appréciables, pour de nombreux usages, par rapport aux thermocouples habituels platine/platine rhodié.

En conséquence, le Comité Consultatif de Thermométrie,

recommande aux laboratoires nationaux de poursuivre leurs recherches sur les méthodes simplifiées et de coût réduit de mesure des températures, en particulier sur ces nouveaux thermocouples pour déterminer leur fonction ainsi que les règles pratiques de construction et d'utilisation qui devraient permettre d'exploiter au mieux leurs possibilités.

6.2.4 The following resolution, instructing the CIPM to develop the ITS-90, was adopted by the 18th CGPM in 1987, and is excerpted from Comptes Rendus, 18^e Conférence Générale des Poids et Mesures (1987), p. 101, Édité par le BIPM, Pavillon de Breteuil, F-92312 Sèvres Cedex, France.

Mise au point d'une nouvelle échelle international de température

RÉSOLUTION 7

La Dix-huitième Conférence Générale des Poids et Mesures,

considérant

que l'uniformité mondiale et la stabilité à long terme des mesures de température sont d'une importance majeure pour la science, le commerce et l'industrie, du point de vue technique comme du point de vue économique,

que la valeur de la température dans l'échelle pratique doit correspondre étroitement à la valeur de la température thermodynamique dans le SI,

que la Quinzième Conférence Générale des Poids et Mesures, ayant pris connaissance des écarts qui ont été mis en évidence entre la valeur de la température dans l'Échelle internationale pratique de température de 1968 (EIPT-68) et la valeur correspondante de la température thermodynamique, a chargé le Comité International des Poids et Mesures d'établir une nouvelle échelle qui devrait être sensiblement plus exacte,

qu'une nouvelle échelle pourra être proposée en 1989, échelle telle que les écarts résiduels avec la température thermodynamique seront négligeables pendant de nombreuses années à venir,

invite le Comité International des Poids et Mesures et les laboratoires nationaux à achever la mise au point de cette nouvelle échelle de température et à fixer une date pour sa mise en application simultanément dans tous les pays; la valeur des écarts entre cette nouvelle échelle et l'EIPT-68 devrait être annoncée au moins un an avant l'adoption de la nouvelle échelle qui pourrait intervenir au 1^{er} janvier 1990.

6.3 We present here examples of some typical Report of Calibration documents from the NIST Calibration Laboratories for thermometers calibrated over various range.

6.3.1 The following report is an example of a Report of Calibration for an SPRT calibrated over the range from 13.8033 K to 505.078 K.

REPORT OF CALIBRATION

International Temperature Scale of 1990

Platinum Resistance Thermometer
L&N Model 8164
Serial Number 1812284

Submitted by
National Institute of Standards and Technology
Gaithersburg, Maryland

This thermometer was calibrated with an AC bridge at a frequency of 30 Hz using a continuous measuring current of 1.0 mA. In accordance with the International Temperature Scale of 1990 (ITS-90) that was officially adopted by the Comité International des Poids et Mesures (CIPM) in September 1989, the subranges from 13.8033 K to 273.16 K and 273.15 K to 505.078 K, with the following fixed points and their stated uncertainties, were used to calibrate the thermometer:

Fixed Point		Temperature		Uncertainty (mK)
		T ₉₀ (K)	t ₉₀ (°C)	
H ₂	TP	13.8033	-259.3467	±0.2
17 K	VP	17.0357	-256.1143	±0.2
20 K	BP	20.2711	-252.8799	±0.2
Ne	TP	24.5561	-248.5939	±0.2
O ₂	TP	54.3584	-218.7916	±0.1
Ar	TP	83.8058	-189.3442	±0.1
Hg	TP	234.3156	-38.8344	±0.1
H ₂ O	TP	273.16	0.01	±0.1
In	FP	429.7485	156.5985	±0.7
Sn	FP	505.078	231.928	±1.0

The following values were determined for the coefficients of the pertinent deviation functions of the ITS-90, as given in the attached material describing the scale. The attached tables were generated using these values.

Coefficients for 1.0 mA Calibration

a ₁ = -2.0257300E-04	b ₁ = -2.7691191E-05
c ₁ = 1.3443513E-05	c ₂ = 5.9700519E-06
c ₃ = 1.1044359E-06	c ₄ = 9.7199229E-08
c ₅ = 3.3585947E-09	
a ₉ = -2.4194948E-04	b ₉ = -2.3366736E-05

The resistance of this thermometer at 273.16 K was calculated to be 25.4975 ohms at 1.0 mA. During calibration, the resistance at 273.16 K changed by the equivalent of 0.1 mK at 1.0 mA.

This thermometer is satisfactory as a defining instrument of the ITS-90 in accordance with the criteria that $W(302.9146 \text{ K}) \geq 1.11807$ or $W(234.3156 \text{ K}) \leq 0.844235$.

For the Director,
National Institute of Standards and Technology

Dr. Hratch G. Semerjian
Chief, Chemical Process Metrology Division
Center for Chemical Technology

Test No. 456123
1 January 1990
P.O. No. 123-456

1 January 1990 ITS-90 Table for PRT S/N 1812284 at 0 mA

T(kelvin)	W(T)	dT/dW(T)	T(kelvin)	W(T)	dT/dW(T)
			15.0	0.00152847	
			15.1	0.00156012	31596.276
			15.2	0.00159242	30959.857
			15.3	0.00162538	30341.117
			15.4	0.00165901	29739.502
			15.5	0.00169331	29154.471
			15.6	0.00172829	28585.499
			15.7	0.00176396	28032.076
			15.8	0.00180033	27493.708
			15.9	0.00183741	26969.914
			16.0	0.00187520	26460.232
			16.1	0.00191372	25964.212
			16.2	0.00195296	25481.419
			16.3	0.00199295	25011.434
			16.4	0.00203367	24553.850
			16.5	0.00207515	24108.276
			16.6	0.00211739	23674.331
			16.7	0.00216040	23251.652
			16.8	0.00220418	22839.884
			16.9	0.00224875	22438.686
			17.0	0.00229410	22047.730
			17.1	0.00234026	21666.698
			17.2	0.00238722	21295.282
			17.3	0.00243499	20933.188
			17.4	0.00248358	20580.129
			17.5	0.00253300	20235.830
			17.6	0.00258325	19900.025
			17.7	0.00263434	19572.457
			17.8	0.00268628	19252.879
			17.9	0.00273907	18941.049
			18.0	0.00279273	18636.739
			18.1	0.00284726	18339.725
			18.2	0.00290266	18049.790
			18.3	0.00295895	17766.728
			18.4	0.00301612	17490.337
			18.5	0.00307419	17220.423
			18.6	0.00313316	16956.799
			18.7	0.00319305	16699.283
			18.8	0.00325385	16447.700
			18.9	0.00331557	16201.882
			19.0	0.00337822	15961.664
			19.1	0.00344180	15726.888
			19.2	0.00350633	15497.402
			19.3	0.00357180	15273.058
			19.4	0.00363823	15053.712
			19.5	0.00370562	14839.227
			19.6	0.00377398	14629.468
			19.7	0.00384330	14424.306
			19.8	0.00391361	14223.616
			19.9	0.00398490	14027.276
			20.0	0.00405718	13835.170
13.8	0.00119642				
13.9	0.00122091	40830.101			
14.0	0.00124595	39934.422			
14.1	0.00127155	39063.736			
14.2	0.00129771	38217.450			
14.3	0.00132445	37394.955			
14.4	0.00135178	36595.625			
14.5	0.00137970	35818.832			
14.6	0.00140822	35063.944			
14.7	0.00143735	34330.332			
14.8	0.00146709	33617.370			
14.9	0.00149747	32924.443			
15.0	0.00152847	32250.944			

1 January 1990 ITS-90 Table for PRT S/N 1812284 at 0 mA

T(kelvin)	W(T)	dT/dW(T)	T(kelvin)	W(T)	dT/dW(T)
20.0	0.00405718		25.0	0.00904141	
20.1	0.00413045	13647.183	25.1	0.00917023	7762.460
20.2	0.00420473	13463.205	25.2	0.00930025	7691.191
20.3	0.00428001	13283.130	25.3	0.00943147	7621.106
20.4	0.00435631	13106.855	25.4	0.00956388	7552.180
20.5	0.00443362	12934.279	25.5	0.00969749	7484.388
20.6	0.00451196	12765.306	25.6	0.00983230	7417.707
20.7	0.00459133	12599.842	25.7	0.00996832	7352.113
20.8	0.00467173	12437.796	25.8	0.01010554	7287.585
20.9	0.00475317	12279.080	25.9	0.01024396	7224.101
21.0	0.00483565	12123.607	26.0	0.01038359	7161.639
21.1	0.00491918	11971.296	26.1	0.01052444	7100.178
21.2	0.00500377	11822.066	26.2	0.01066649	7039.699
21.3	0.00508942	11675.839	26.3	0.01080975	6980.181
21.4	0.00517613	11532.539	26.4	0.01095423	6921.605
21.5	0.00526391	11392.094	26.5	0.01109991	6863.953
21.6	0.00535276	11254.431	26.6	0.01124682	6807.205
21.7	0.00544270	11119.482	26.7	0.01139494	6751.345
21.8	0.00553371	10987.179	26.8	0.01154427	6696.354
21.9	0.00562581	10857.459	26.9	0.01169482	6642.216
22.0	0.00571901	10730.257	27.0	0.01184659	6588.913
22.1	0.00581330	10605.512	27.1	0.01199958	6536.430
22.2	0.00590869	10483.165	27.2	0.01215379	6484.750
22.3	0.00600519	10363.157	27.3	0.01230922	6433.858
22.4	0.00610279	10245.434	27.4	0.01246587	6383.739
22.5	0.00620151	10129.940	27.5	0.01262373	6334.379
22.6	0.00630134	10016.622	27.6	0.01278282	6285.761
22.7	0.00640230	9905.428	27.7	0.01294314	6237.874
22.8	0.00650438	9796.310	27.8	0.01310467	6190.702
22.9	0.00660758	9689.217	27.9	0.01326742	6144.231
23.0	0.00671192	9584.103	28.0	0.01343140	6098.450
23.1	0.00681740	9480.922	28.1	0.01359660	6053.345
23.2	0.00692401	9379.629	28.2	0.01376302	6008.904
23.3	0.00703177	9280.181	28.3	0.01393066	5965.113
23.4	0.00714067	9182.535	28.4	0.01409952	5921.962
23.5	0.00725072	9086.650	28.5	0.01426960	5879.438
23.6	0.00736193	8992.487	28.6	0.01444091	5837.530
23.7	0.00747429	8900.006	28.7	0.01461344	5796.226
23.8	0.00758780	8809.169	28.8	0.01478718	5755.516
23.9	0.00770248	8719.941	28.9	0.01496215	5715.389
24.0	0.00781833	8632.284	29.0	0.01513833	5675.834
24.1	0.00793534	8546.165	29.1	0.01531574	5636.841
24.2	0.00805352	8461.548	29.2	0.01549436	5598.400
24.3	0.00817288	8378.401	29.3	0.01567420	5560.501
24.4	0.00829341	8296.693	29.4	0.01585526	5523.135
24.5	0.00841511	8216.391	29.5	0.01603753	5486.292
24.6	0.00853800	8137.464	29.6	0.01622102	5449.962
24.7	0.00866207	8059.885	29.7	0.01640572	5414.138
24.8	0.00878733	7983.622	29.8	0.01659163	5378.809
24.9	0.00891377	7908.648	29.9	0.01677876	5343.968
25.0	0.00904141	7834.937	30.0	0.01696710	5309.606

6.3.2 The following report is an example of a Report of Calibration for an SPRT calibrated over the range from 83.8058 K to 933.473 K.

REPORT OF CALIBRATION

International Temperature Scale of 1990

Platinum Resistance Thermometer
Chino Model R800-2
Serial Number RS59A-8

Submitted by
National Institute of Standards and Technology
Gaithersburg, Maryland

This platinum resistance thermometer (PRT) was calibrated with an AC bridge at a frequency of 30 Hz using continuous measuring currents of 1.0 mA and 2.0 mA. In accordance with the International Temperature Scale of 1990 (ITS-90) that was officially adopted by the Comité International des Poids et Mesures (CIPM) in September 1989, the subranges from 83.8058 K to 273.16 K and 273.15 K to 933.473 K, with the following fixed points and their stated uncertainties, were used to calibrate the thermometer:

Fixed Point		Temperature		Uncertainty
		$T_{90}(\text{K})$	$t_{90}(\text{°C})$	(mK)
Ar	TP	83.8058	-189.3442	± 0.1
Hg	TP	234.3156	-38.8344	± 0.1
H ₂ O	TP	273.16	0.01	± 0.1
Sn	FP	505.078	231.928	± 1.0
Zn	FP	692.677	419.527	± 1.0
Al	FP	933.473	660.323	± 1.0

The following values were determined for the coefficients of the pertinent deviation functions of the ITS-90, as given in the attached material describing the scale. The attached tables were generated using these values.

Coefficients for Zero-Power Dissipation Calibration

$$\begin{aligned} a_4 &= -3.2324853\text{E-}04 & b_4 &= 1.2626274\text{E-}05 \\ a_7 &= -3.6461515\text{E-}04 & b_7 &= -8.5363999\text{E-}06 \\ c_7 &= 1.4664695\text{E-}06 \end{aligned}$$

Coefficients for 1.0 mA Calibration

$$\begin{aligned} a_4 &= -3.2877518\text{E-}04 & b_4 &= 1.1459514\text{E-}05 \\ a_7 &= -3.5921484\text{E-}04 & b_7 &= -1.8940305\text{E-}05 \\ c_7 &= 3.7262747\text{E-}06 \end{aligned}$$

The resistance of this thermometer at 273.16 K was calculated to be 25.0694 ohms at zero-power dissipation and 25.0696 ohms at 1.0 mA. During calibration, the resistance at 273.16 K changed by the equivalent of 0.4 mK at zero-power dissipation and 0.3 mK at 1.0 mA.

This thermometer is satisfactory as a defining instrument of the ITS-90 in accordance with the criteria that $W(302.9146 \text{ K}) \geq 1.11807$ or $W(234.3156 \text{ K}) \leq 0.844235$. For the PRT to be acceptable for use between the freezing points of aluminum and silver, it must also meet the additional criterion: $W(1234.93 \text{ K}) \geq 4.2844$.

For the Director,
National Institute of Standards and Technology

Dr. Hratch G. Semerjian
Chief, Chemical Process Metrology Division
Center for Chemical Technology

Test No. 456123
1 January 1990
P.O. No. 123-456

1 January 1990

ITS-90 Table for PRT S/N RS59A-8 at 0 mA

t(Celsius)	W(t)	dt/dW(t)	t(Celsius)	W(t)	dt/dW(t)
0	0.99996012		50	1.19779810	
1	1.00394660	250.8476	51	1.20172407	254.7139
2	1.00793186	250.9248	52	1.20564884	254.7919
3	1.01191590	251.0016	53	1.20957241	254.8700
4	1.01589872	251.0784	54	1.21349478	254.9481
5	1.01988032	251.1552	55	1.21741595	255.0262
6	1.02386070	251.2320	56	1.22133591	255.1043
7	1.02783987	251.3089	57	1.22525468	255.1825
8	1.03181782	251.3857	58	1.22917224	255.2607
9	1.03579456	251.4626	59	1.23308860	255.3390
10	1.03977008	251.5395	60	1.23700376	255.4173
11	1.04374438	251.6164	61	1.24091772	255.4956
12	1.04771747	251.6934	62	1.24483049	255.5740
13	1.05168934	251.7703	63	1.24874205	255.6523
14	1.05566000	251.8473	64	1.25265241	255.7308
15	1.05962945	251.9243	65	1.25656157	255.8092
16	1.06359768	252.0014	66	1.26046954	255.8877
17	1.06756470	252.0784	67	1.26437630	255.9662
18	1.07153051	252.1555	68	1.26828187	256.0448
19	1.07549510	252.2326	69	1.27218624	256.1234
20	1.07945848	252.3097	70	1.27608941	256.2020
21	1.08342066	252.3869	71	1.27999138	256.2806
22	1.08738162	252.4640	72	1.28389216	256.3593
23	1.09134137	252.5412	73	1.28779173	256.4381
24	1.09529990	252.6184	74	1.29169011	256.5168
25	1.09925723	252.6957	75	1.29558730	256.5956
26	1.10321335	252.7730	76	1.29948328	256.6744
27	1.10716826	252.8503	77	1.30337807	256.7533
28	1.11112196	252.9276	78	1.30727166	256.8322
29	1.11507446	253.0049	79	1.31116406	256.9111
30	1.11902574	253.0823	80	1.31505526	256.9901
31	1.12297582	253.1597	81	1.31894527	257.0691
32	1.12692468	253.2371	82	1.32283408	257.1481
33	1.13087234	253.3146	83	1.32672169	257.2272
34	1.13481880	253.3921	84	1.33060811	257.3063
35	1.13876404	253.4696	85	1.33449333	257.3854
36	1.14270808	253.5472	86	1.33837736	257.4646
37	1.14665092	253.6247	87	1.34226020	257.5438
38	1.15059254	253.7023	88	1.34614183	257.6231
39	1.15453296	253.7800	89	1.35002228	257.7024
40	1.15847218	253.8576	90	1.35390153	257.7817
41	1.16241019	253.9353	91	1.35777959	257.8610
42	1.16634700	254.0130	92	1.36165645	257.9404
43	1.17028260	254.0908	93	1.36553213	258.0198
44	1.17421699	254.1686	94	1.36940660	258.0993
45	1.17815019	254.2464	95	1.37327989	258.1788
46	1.18208218	254.3242	96	1.37715198	258.2583
47	1.18601296	254.4021	97	1.38102288	258.3379
48	1.18994254	254.4800	98	1.38489259	258.4175
49	1.19387092	254.5579	99	1.38876110	258.4971
50	1.19779810	254.6359	100	1.39262843	258.5768

6.3.3 The following report is an example of a Report of Calibration for an SPRT calibrated over the range from 273.15 K to 1234.93 K.

REPORT OF CALIBRATION

International Temperature Scale of 1990

Platinum Resistance Thermometer
Chino Model R800-3, 0.25 ohm
Serial Number RS78A-2

Submitted by
National Institute of Standards and Technology
Gaithersburg, Maryland

This platinum resistance thermometer (PRT) was calibrated with an AC bridge at a frequency of 30 Hz using continuous measuring currents of 5.0 mA and 10.0 mA. In accordance with the International Temperature Scale of 1990 (ITS-90) that was officially adopted by the Comité International des Poids et Mesures (CIPM) in September 1989, the subrange from 273.15 K to 1234.93 K, with the following fixed points and their stated uncertainties, was used to calibrate the thermometer:

Fixed Point		Temperature		Uncertainty (mK)
		T ₉₀ (K)	t ₉₀ (°C)	
H ₂ O	TP	273.16	0.01	±0.1
Sn	FP	505.078	231.928	±1.0
Zn	FP	692.677	419.527	±1.0
Al	FP	933.473	660.323	±1.0
Ag	FP	1234.93	961.78	±2.0

The following values were determined for the coefficients of the pertinent deviation functions of the ITS-90, as given in the attached material describing the scale. The attached tables were generated using these values.

Coefficients for Zero-Power Dissipation Calibration

$$\begin{aligned} a_6 &= -1.1296072\text{E-}04 & b_6 &= 1.1080496\text{E-}04 \\ c_6 &= -3.5516098\text{E-}05 & d &= 3.6725603\text{E-}04 \end{aligned}$$

Coefficients for 5.0 mA Calibration

$$\begin{aligned} a_6 &= -9.2794623\text{E-}05 & b_6 &= 8.3014954\text{E-}05 \\ c_6 &= -2.7075707\text{E-}05 & d &= 2.8767080\text{E-}04 \end{aligned}$$

The resistance of this thermometer at 273.16 K was calculated to be 0.2553 ohms at zero-power dissipation and 0.2553 ohms at 5.0 mA. During calibration, the resistance at 273.16 K changed by the equivalent of 2.0 mK at zero-power dissipation and 1.6 mK at 1.0 mA.

This thermometer is satisfactory as a defining instrument of the ITS-90 in accordance with the criteria that $W(302.9146 \text{ K}) \geq 1.11807$ or $W(234.3156 \text{ K}) \leq 0.844235$. For the PRT to be acceptable for use between the freezing points of aluminum and silver, it must also meet the additional criterion: $W(1234.93 \text{ K}) \geq 4.2844$.

For the Director,
National Institute of Standards and Technology

Dr. Hratch G. Semerjian
Chief, Chemical Process Metrology Division
Center for Chemical Technology

Test No. 456123
1 January 1990
P.O. No. 123-456

1 January 1990

ITS-90 Table for PRT S/N RS78A-2 at 0 mA

t(Celsius)	W(t)	dt/dW(t)	t(Celsius)	W(t)	dt/dW(t)
0	0.99996011		50	1.19785226	
1	1.00394760	250.7845	51	1.20177939	254.6388
2	1.00793386	250.8613	52	1.20570532	254.7166
3	1.01191891	250.9378	53	1.20963005	254.7944
4	1.01590275	251.0144	54	1.21355358	254.8723
5	1.01988537	251.0909	55	1.21747592	254.9502
6	1.02386678	251.1675	56	1.22139705	255.0282
7	1.02784697	251.2441	57	1.22531699	255.1061
8	1.03182595	251.3207	58	1.22923573	255.1842
9	1.03580372	251.3973	59	1.23315327	255.2622
10	1.03978027	251.4740	60	1.23706961	255.3403
11	1.04375561	251.5507	61	1.24098476	255.4184
12	1.04772974	251.6274	62	1.24489871	255.4965
13	1.05170266	251.7041	63	1.24881146	255.5747
14	1.05567437	251.7808	64	1.25272301	255.6529
15	1.05964487	251.8576	65	1.25663337	255.7312
16	1.06361416	251.9344	66	1.26054252	255.8094
17	1.06758223	252.0112	67	1.26445049	255.8878
18	1.07154910	252.0880	68	1.26835726	255.9661
19	1.07551476	252.1649	69	1.27226283	256.0445
20	1.07947921	252.2417	70	1.27616720	256.1229
21	1.08344246	252.3186	71	1.28007038	256.2014
22	1.08740449	252.3956	72	1.28397237	256.2799
23	1.09136532	252.4725	73	1.28787316	256.3584
24	1.09532494	252.5495	74	1.29177275	256.4369
25	1.09928335	252.6265	75	1.29567115	256.5155
26	1.10324056	252.7036	76	1.29956835	256.5942
27	1.10719656	252.7806	77	1.30346436	256.6728
28	1.11115135	252.8577	78	1.30735918	256.7515
29	1.11510494	252.9348	79	1.31125280	256.8303
30	1.11905732	253.0120	80	1.31514523	256.9090
31	1.12300850	253.0891	81	1.31903647	256.9878
32	1.12695847	253.1663	82	1.32292651	257.0667
33	1.13090724	253.2436	83	1.32681536	257.1456
34	1.13485480	253.3208	84	1.33070301	257.2245
35	1.13880116	253.3981	85	1.33458947	257.3034
36	1.14274631	253.4754	86	1.33847474	257.3824
37	1.14669027	253.5528	87	1.34235882	257.4614
38	1.15063302	253.6301	88	1.34624170	257.5405
39	1.15457456	253.7075	89	1.35012340	257.6196
40	1.15851491	253.7850	90	1.35400390	257.6987
41	1.16245405	253.8624	91	1.35788321	257.7779
42	1.16639199	253.9399	92	1.36176132	257.8571
43	1.17032872	254.0175	93	1.36563825	257.9363
44	1.17426426	254.0950	94	1.36951398	258.0156
45	1.17819859	254.1726	95	1.37338853	258.0949
46	1.18213173	254.2502	96	1.37726188	258.1743
47	1.18606366	254.3279	97	1.38113404	258.2536
48	1.18999439	254.4055	98	1.38500501	258.3331
49	1.19392392	254.4833	99	1.38887480	258.4125
50	1.19785226	254.5610	100	1.39274339	258.4920

6.3.4 The following is an example of a Report giving the T_{68} to T_{90} conversion for a long-stem type SPRT calibrated on the IPTS-68(75) from the oxygen condensation point to the freezing point of zinc.

TEST REPORT

International Temperature Scale of 1990

Platinum Resistance Thermometer
Chino Model R800-2
Serial Number RS8YA-5

Submitted by
National Institute of Standards and Technology
Gaithersburg, Maryland

This thermometer was calibrated 1 March 1989 on the International Practical Temperature Scale of 1968 (IPTS-68) and that calibration has been converted to the International Temperature Scale of 1990 (ITS-90). The IPTS-68 calibration was performed with a DC bridge at a continuous current of 1.0 mA. The $W(T_{90})$ values for the triple point of mercury and the triple point of argon were calculated from the IPTS-68 coefficients.

Fixed Point		Temperature		Uncertainty (mK)
		T_{90} (K)	t_{90} (°C)	
Ar	TP	83.8058	-189.3442	±0.1
Hg	TP	234.3156	-38.8344	±0.1
H ₂ O	TP	273.16	0.01	±0.1
Sn	FP	505.078	231.928	±1.0
Zn	FP	692.677	419.527	±1.0

The following values were determined for the coefficients of the pertinent deviation functions of the ITS-90, as given in the attached material describing the scale. The attached tables were generated using these values.

Coefficients for 1.0 mA Calibration

$$\begin{aligned} a_4 &= -9.3225823E-05 & b_4 &= -9.9914440E-06 \\ a_8 &= -9.1058813E-05 & b_8 &= -7.6061559E-06 \end{aligned}$$

The resistance of this thermometer at 273.16 K was calculated to be 25.5096 ohms at 1.0 mA. During calibration, the resistance at 273.16 K changed by the equivalent of 0.5 mK at 1.0 mA.

This thermometer is satisfactory as a defining instrument of the ITS-90 in accordance with the criteria that $W(302.9146 \text{ K}) \geq 1.11807$ or $W(234.3156 \text{ K}) \leq 0.844235$. For the PRT to be acceptable for use between the freezing points of aluminum and silver, it must also meet the additional criterion: $W(1234.93 \text{ K}) \geq 4.2844$.

For the Director,
National Institute of Standards and Technology

Dr. Hratch G. Semerjian
Chief, Chemical Process Metrology Division
Center for Chemical Technology

Test No. 456123
1 January 1990
P.O. No. 123-456

1 January 1990

ITS-90 Table for PRT S/N RS8YA-5

at 1 mA

t(Celsius)	W(t)	dt/dW(t)	t(Celsius)	W(t)	dt/dW(t)
0	0.99996011		50	1.19785223	
1	1.00394768	250.7791	51	1.20177928	254.6442
2	1.00793403	250.8562	52	1.20570512	254.7222
3	1.01191916	250.9329	53	1.20962977	254.8002
4	1.01590307	251.0097	54	1.21355321	254.8783
5	1.01988576	251.0865	55	1.21747545	254.9564
6	1.02386723	251.1633	56	1.22139648	255.0345
7	1.02784749	251.2401	57	1.22531632	255.1127
8	1.03182653	251.3170	58	1.22923496	255.1909
9	1.03580435	251.3938	59	1.23315239	255.2691
10	1.03978096	251.4707	60	1.23706862	255.3474
11	1.04375635	251.5476	61	1.24098366	255.4257
12	1.04773052	251.6245	62	1.24489749	255.5040
13	1.05170348	251.7015	63	1.24881012	255.5824
14	1.05567523	251.7784	64	1.25272155	255.6608
15	1.05964576	251.8554	65	1.25663179	255.7392
16	1.06361508	251.9324	66	1.26054082	255.8177
17	1.06758318	252.0095	67	1.26444866	255.8962
18	1.07155008	252.0865	68	1.26835529	255.9747
19	1.07551576	252.1636	69	1.27226073	256.0533
20	1.07948022	252.2407	70	1.27616497	256.1319
21	1.08344348	252.3178	71	1.28006801	256.2105
22	1.08740552	252.3950	72	1.28396985	256.2892
23	1.09136636	252.4721	73	1.28787050	256.3679
24	1.09532598	252.5493	74	1.29176994	256.4466
25	1.09928439	252.6266	75	1.29566819	256.5254
26	1.10324159	252.7038	76	1.29956524	256.6042
27	1.10719759	252.7811	77	1.30346110	256.6830
28	1.11115237	252.8584	78	1.30735576	256.7619
29	1.11510594	252.9357	79	1.31124922	256.8408
30	1.11905831	253.0131	80	1.31514149	256.9198
31	1.12300946	253.0904	81	1.31903255	256.9988
32	1.12695941	253.1679	82	1.32292243	257.0778
33	1.13090815	253.2453	83	1.32681111	257.1568
34	1.13485569	253.3228	84	1.33069859	257.2359
35	1.13880201	253.4003	85	1.33458488	257.3150
36	1.14274713	253.4778	86	1.33846997	257.3942
37	1.14669104	253.5553	87	1.34235386	257.4734
38	1.15063375	253.6329	88	1.34623657	257.5526
39	1.15457525	253.7105	89	1.35011807	257.6319
40	1.15851554	253.7882	90	1.35399839	257.7112
41	1.16245463	253.8658	91	1.35787751	257.7905
42	1.16639252	253.9435	92	1.36175543	257.8698
43	1.17032919	254.0212	93	1.36563216	257.9493
44	1.17426467	254.0990	94	1.36950770	258.0287
45	1.17819894	254.1768	95	1.37338205	258.1082
46	1.18213200	254.2546	96	1.37725520	258.1877
47	1.18606386	254.3325	97	1.38112716	258.2672
48	1.18999452	254.4103	98	1.38499792	258.3468
49	1.19392398	254.4883	99	1.38886750	258.4264
50	1.19785223	254.5662	100	1.39273588	258.5061

6.3.5 The following is an example of a Report giving the T_{68} to T_{90} conversion for a capsule-type SPRT calibrated on the IPTS-68(75) from the triple point of equilibrium hydrogen to the freezing point of tin.

TEST REPORT

International Temperature Scale of 1990

Platinum Resistance Thermometer
 L&N Model 8164
 Serial Number 1812284

Submitted by
 National Institute of Standards and Technology
 Gaithersburg, Maryland

This thermometer was calibrated 21 September 1989 on the International Practical Temperature Scale of 1968 (IPTS-68) and that calibration has been converted to the International Temperature Scale of 1990 (ITS-90). The IPTS-68 calibration was performed with an AC bridge at a continuous current of 1.0 mA. The $W(T_{90})$ values for the triple point of neon, the triple point of mercury, the triple point of argon, and the freezing point of indium were calculated from the IPTS-68 coefficients.

Fixed Point		Temperature		Uncertainty
		$T_{90}(K)$	$t_{90}(^{\circ}C)$	(mK)
H ₂	TP	13.8033	-259.3467	±0.2
17 K	VP	17.0301	-256.1143	±0.2
20 K	BP	20.2701	-252.8799	±0.2
Ne	TP	24.5561	-248.5939	±0.2
O ₂	TP	54.3584	-218.7916	±0.2
Ar	TP	83.8058	-189.3442	±0.1
Hg	TP	234.3156	-38.8344	±0.1
H ₂ O	TP	273.16	0.01	±0.1
In	FP	429.7485	156.5985	±0.7
Sn	FP	505.078	231.928	±1.0

The following values were determined for the coefficients of the pertinent deviation functions of the ITS-90, as given in the attached material describing the scale. The attached tables were generated using these values.

Coefficients for 1.0 mA Calibration

$a_1 = -2.5239001E-04$	$b_1 = -1.2277862E-04$
$c_1 = -2.3783015E-06$	$c_2 = -4.3892024E-06$
$c_3 = -1.5608728E-06$	$c_4 = -2.1374663E-07$
$c_5 = -1.0344171E-08$	
$a_9 = -2.5287142E-04$	$b_9 = -1.1130131E-05$

The resistance of this thermometer at 273.16 K was calculated to be 25.4975 ohms at 1.0 mA. During calibration, the resistance at 273.16 K changed by the equivalent of 0.1 mK at 1.0 mA.

This thermometer is satisfactory as a defining instrument of the ITS-90 in accordance with the criteria that $W(302.9146 K) \geq 1.11807$ or $W(234.3156 K) \leq 0.844235$.

For the Director,
 National Institute of Standards and Technology

Dr. Hratch G. Semerjian
 Chief, Chemical Process Metrology Division
 Center for Chemical Technology

Test No. 456123
 1 January 1990
 P.O. No. 123-456

1 January 1990

ITS-90 Table for PRT S/N 1812284

at 0 mA

T(kelvin)	W(T)	dT/dW(T)	T(kelvin)	W(T)	dT/dW(T)
20.0	0.00405854	13651.443	25.0	0.00904032	7765.161
20.1	0.00413180	13467.816	25.1	0.00916910	7693.784
20.2	0.00420605	13288.054	25.2	0.00929907	7623.594
20.3	0.00428130	13112.056	25.3	0.00943025	7554.564
20.4	0.00435757	12939.724	25.4	0.00956262	7486.671
20.5	0.00443485	12770.963	25.5	0.00969619	7419.891
20.6	0.00451315	12605.681	25.6	0.00983096	7354.201
20.7	0.00459248	12443.789	25.7	0.00996694	7289.579
20.8	0.00467284	12285.200	25.8	0.01010412	7226.003
20.9	0.00475424	12129.832	25.9	0.01024251	7163.451
21.0	0.00483668	11977.602	26.0	0.01038210	7101.904
21.1	0.00492017	11828.432	26.1	0.01052291	7041.339
21.2	0.00500471	11682.245	26.2	0.01066493	6981.739
21.3	0.00509031	11538.968	26.3	0.01080816	6923.083
21.4	0.00517698	11398.528	26.4	0.01095261	6865.353
21.5	0.00526471	11260.856	26.5	0.01109826	6808.530
21.6	0.00535351	11125.883	26.6	0.01124514	6752.596
21.7	0.00544339	10993.545	26.7	0.01139323	6697.534
21.8	0.00553435	10863.776	26.8	0.01154254	6643.327
21.9	0.00562640	10736.516	26.9	0.01169307	6589.957
22.0	0.00571954	10611.702	27.0	0.01184481	6537.409
22.1	0.00581378	10489.278	27.1	0.01199778	6485.667
22.2	0.00590911	10369.186	27.2	0.01215196	6434.715
22.3	0.00600555	10251.371	27.3	0.01230737	6384.537
22.4	0.00610310	10135.779	27.4	0.01246400	6335.120
22.5	0.00620176	10022.357	27.5	0.01262185	6286.448
22.6	0.00630154	9911.055	27.6	0.01278092	6238.507
22.7	0.00640244	9801.824	27.7	0.01294122	6191.284
22.8	0.00650446	9694.615	27.8	0.01310273	6144.765
22.9	0.00660761	9589.382	27.9	0.01326547	6098.936
23.0	0.00671189	9486.079	28.0	0.01342944	6053.785
23.1	0.00681731	9384.662	28.1	0.01359462	6009.300
23.2	0.00692386	9285.088	28.2	0.01376103	5965.467
23.3	0.00703156	9187.315	28.3	0.01392866	5922.275
23.4	0.00714041	9091.302	28.4	0.01409752	5879.711
23.5	0.00725041	8997.011	28.5	0.01426759	5837.765
23.6	0.00736155	8904.401	28.6	0.01443889	5796.426
23.7	0.00747386	8813.437	28.7	0.01461141	5755.681
23.8	0.00758732	8724.080	28.8	0.01478515	5715.520
23.9	0.00770195	8636.296	28.9	0.01496012	5675.933
24.0	0.00781774	8550.050	29.0	0.01513630	5636.910
24.1	0.00793469	8465.308	29.1	0.01531370	5598.439
24.2	0.00805282	8382.037	29.2	0.01549232	5560.512
24.3	0.00817213	8300.205	29.3	0.01567216	5523.119
24.4	0.00829261	8219.782	29.4	0.01585322	5486.250
24.5	0.00841426	8140.736	29.5	0.01603549	5449.896
24.6	0.00853710	8063.038	29.6	0.01621898	5414.048
24.7	0.00866112	7986.659	29.7	0.01640369	5378.697
24.8	0.00878633	7911.572	29.8	0.01658961	5343.835
24.9	0.00891273	7837.748	29.9	0.01677674	5309.452
25.0	0.00904032		30.0	0.01696508	

6.3.6 The following is an example of a Report of Calibration for an RIRT calibrated over the range from 0.50 K to 30 K on the EPT-76.

UNITED STATES DEPARTMENT OF COMMERCE
NATIONAL INSTITUTE OF STANDARDS AND TECHNOLOGY
NATIONAL MEASUREMENT LABORATORY
GAITHERSBURG, MARYLAND 20899

REPORT OF CALIBRATION

1976 Provisional 0.5 K to 30 K Temperature Scale (EPT-76)

Rhodium-Iron Resistance Thermometer
Serial Number B189

Submitted by
NIST - Thermometry Group
Gaithersburg, MD 20899

This resistance thermometer was calibrated by comparison under isothermal conditions with a set of stable reference rhodium-iron resistance thermometers. A table listing thermometer resistance R as a function of temperature T follows. This table constitutes the calibration.

In addition, as a convenience to the user, least-squares polynomial smoothings of the calibration data have been done. A table of temperature, resistance, and the first and second derivatives of resistance with respect to temperature has been generated from a selected polynomial.

This thermometer was calibrated using an AC bridge at a frequency of 30 Hz using excitation currents of 0.125 mA below 1 K and 0.25 mA above 1 K. The current was maintained through the thermometer only during the actual time when measurements of resistance were made.

For the Director,
National Institute of Standards and Technology

B. W. Mangum, Physicist
Temperature and Pressure Division
Center for Chemical Technology

Test No. 12345
29 December 1989
Purchase Order No. 123456789

* RHODIUM-IRON THERMOMETER B189
 * Calibrated for NIST—Thermometry Group
 * Calibrated on EPT-76, May-June 1988

Calibration Current = 0.125, 0.25 mA
 Weight = (dT/dR)**2

T(K)	R(ohms)	Weight	I(mA)
: 0.43976	4.293722	2.87	0.125
: 0.51872	4.340174	2.86	0.125
: 0.64985	4.417578	2.87	0.125
: 0.85100	4.536304	2.89	0.125
: 1.02827	4.640395	2.92	0.25
: 1.18271	4.730482	2.96	0.25
: 1.30962	4.804059	3.00	0.25
: 1.72215	5.039635	3.15	0.25
: 2.17154	5.288860	3.37	0.25
: 2.47997	5.454826	3.55	0.25
: 3.41404	5.930224	4.22	0.25
: 4.22195	6.308779	4.93	0.25
: 4.50339	6.433776	5.21	0.25
: 5.76304	6.953086	6.64	0.25
: 7.19977	7.475341	8.62	0.25
: 8.78512	7.980605	11.2	0.25
: 10.45483	8.447636	14.5	0.25
: 12.14414	8.865576	18.4	0.25
: 13.80845	9.233974	22.7	0.25
: 15.42337	9.557786	27.3	0.25
: 17.03860	9.854363	32.2	0.25
: 18.65600	10.128928	37.3	0.25
: 20.27451	10.385641	42.2	0.25
: 21.84940	10.621898	46.6	0.25
: 23.30557	10.831357	49.9	0.25
: 24.55872	11.006661	52.1	0.25
: 25.54642	11.142596	53.4	0.25
: 26.25499	11.239309	54.0	0.25
: 26.69840	11.299615	54.2	0.25
: 26.95381	11.334286	54.3	0.25
: 27.10184	11.354377	54.3	0.25
: 27.21302	11.369470	54.3	0.25

09/08/88 - ERP

12th order R-T fit, s.d. = 0.11 mK

05/10/90 -- 11:09:50
RIB189 RESIST-841023

RHODIUM-IRON THERMOMETER B189
Calibrated for NIST--Thermometry Group
Calibrated on EPT-76, May-June 1988

FORTRAN POLYFIT

AN ORTHONORMAL LEAST-SQUARES FITTING OF THE POLYNOMIAL

$$R = \sum_{J=0}^{J=N} A_{J,N} T^J, \quad N = P, P+1, P+2 \dots$$

The fitting is done in double-precision arithmetic. The computer is programmed to select the best polynomial fitting from which to generate a table of temperature, resistance, and the first and second derivatives of resistance with respect to temperature. The page listing the coefficients of the selected polynomial is clearly marked at the bottom.

The deviations of each fitted polynomial from the calibration data are given in the columns headed "Delta R" and "Delta T". The first and second derivatives of each fitted polynomial (in terms of the fitted variables) may be given also.

This analysis and the resultant generated table are provided for convenience in interpolating between the calibration points and do not constitute the calibration.

This is a fitting of EPT-76 calibration data for the range 0.5 K to 27.1 K.

Table derived from lowest order fit where the ratio of the coefficients to their standard deviations exceeds 2.00 and the absolute value of each delta T is less than 0.25 mK.
Read in 32 data points, 32 of which used for fit.

RHODIUM-IRON THERMOMETER B189

Order of fit = 11

Coefficients	Standard Deviation	Ratio
A 0 = 0.40346134471597D+01	0.25194D-03	16014.35
A 1 = 0.58409816514135D+00	0.64209D-03	909.68
A 2 = 0.15633522974138D-01	0.56019D-03	27.91
A 3 = -0.12524188561487D-01	0.23576D-03	53.12
A 4 = 0.22840914978526D-02	0.56075D-04	40.73
A 5 = -0.25486508579045D-03	0.82209D-05	31.00
A 6 = 0.19197133210465D-04	0.77838D-06	24.66
A 7 = -0.99199256393158D-06	0.48505D-07	20.45
A 8 = 0.34640351265831D-07	0.19767D-08	17.52
A 9 = -0.78061577738577D-09	0.50701D-10	15.40
A10 = 0.10239549134372D-10	0.74266D-12	13.79
A11 = -0.59357426776446D-13	0.47369D-14	12.53

Standard Deviation of Fit = 0.374764E-04 Ohms

T Kelvins	R Ohms	R Calculated Ohms	Delta R Ohms	Delta T mKelvins	Weight
0.4398	4.29372	4.29352	0.00021	-0.348	2.87000
0.5187	4.34017	4.34021	-0.00004	0.063	2.86000
0.6499	4.41758	4.41773	-0.00016	0.264	2.87000
0.8510	4.53630	4.53638	-0.00007	0.121	2.89000
1.0283	4.64040	4.64042	-0.00002	0.042	2.92000
1.1827	4.73048	4.73051	-0.00003	0.047	2.96000
1.3096	4.80406	4.80407	-0.00001	0.019	3.00000
1.7221	5.03964	5.03960	0.00003	-0.053	3.15000
2.1715	5.28886	5.28877	0.00009	-0.173	3.37000
2.4800	5.45483	5.45471	0.00011	-0.210	3.55000
3.4140	5.93022	5.93032	-0.00009	0.188	4.22000
4.2220	6.30878	6.30881	-0.00003	0.076	4.93000
4.5034	6.43378	6.43378	-0.00001	0.017	5.21000
5.7630	6.95309	6.95310	-0.00001	0.028	6.64000
7.1998	7.47534	7.47532	0.00002	-0.066	8.62000
8.7851	7.98061	7.98056	0.00004	-0.149	11.20000
10.4548	8.44764	8.44767	-0.00004	0.134	14.50000
12.1441	8.86558	8.86561	-0.00003	0.141	18.39999
13.8085	9.23397	9.23394	0.00003	-0.139	22.70000
15.4234	9.55779	9.55776	0.00003	-0.134	27.29999
17.0386	9.85436	9.85438	-0.00002	0.118	32.20000
18.6560	10.12893	10.12895	-0.00002	0.143	37.29999
20.2745	10.38564	10.38562	0.00002	-0.127	42.20000
21.8494	10.62190	10.62188	0.00002	-0.145	46.59999
23.3056	10.83136	10.83139	-0.00003	0.221	49.89999
24.5587	11.00666	11.00666	-0.00000	0.023	52.09999
25.5464	11.14260	11.14257	0.00003	-0.183	53.39999
26.2550	11.23931	11.23931	0.00000	-0.025	54.00000
26.6984	11.29962	11.29963	-0.00001	0.083	54.20000
26.9538	11.33429	11.33431	-0.00002	0.151	54.29999
27.1018	11.35438	11.35438	-0.00001	0.040	54.29999
27.2130	11.36947	11.36945	0.00002	-0.166	54.29999

Standard Deviation of R = 0.00160 Percent

Standard Deviation of T = 0.18001 mKelvins

RHODIUM-IRON THERMOMETER B189

Order of fit = 12

	Coefficients	Standard Deviation	Ratio
A 0 =	0.40353440386808D+01	0.18126D-03	22262.26
A 1 =	0.58168124946786D+00	0.51824D-03	1122.41
A 2 =	0.18315122509405D-01	0.51786D-03	35.37
A 3 =	-0.13936140688461D-01	0.25342D-03	54.99
A 4 =	0.27019102278194D-02	0.71194D-04	37.95
A 5 =	-0.33123326008865D-03	0.12540D-04	26.41
A 6 =	0.28300891747533D-04	0.14562D-05	19.44
A 7 =	-0.17202688448061D-05	0.11436D-06	15.04
A 8 =	0.74047308522468D-07	0.61099D-08	12.12
A 9 =	-0.22037748481731D-08	0.21880D-09	10.07
A10 =	0.43099007915774D-10	0.50258D-11	8.58
A11 =	-0.49803414711131D-12	0.66912D-13	7.44
A12 =	0.25757636010739D-14	0.39257D-15	6.56

***** THESE COEFFICIENTS SELECTED FOR THE GENERATED TABLE *****

Standard Deviation of Fit = 0.212764E-04 Ohms

T	R	R Calculated	Delta R	Delta T	Weight
Kelvins	Ohms	Ohms	Ohms	mKelvins	
0.4398	4.29372	4.29360	0.00013	-0.212	2.87000
0.5187	4.34017	4.34024	-0.00007	0.112	2.86000
0.6499	4.41758	4.41771	-0.00013	0.215	2.87000
0.8510	4.53630	4.53631	-0.00001	0.009	2.89000
1.0283	4.64040	4.64035	0.00004	-0.070	2.92000
1.1827	4.73048	4.73046	0.00002	-0.037	2.96000
1.3096	4.80406	4.80404	0.00002	-0.034	3.00000
1.7221	5.03964	5.03964	-0.00001	0.010	3.15000
2.1715	5.28886	5.28884	0.00002	-0.028	3.37000
2.4800	5.45483	5.45480	0.00003	-0.053	3.55000
3.4140	5.93022	5.93033	-0.00011	0.217	4.22000
4.2220	6.30878	6.30876	0.00002	-0.035	4.93000
4.5034	6.43378	6.43372	0.00005	-0.119	5.21000
5.7630	6.95309	6.95307	0.00001	-0.029	6.64000
7.1998	7.47534	7.47537	-0.00003	0.096	8.62000
8.7851	7.98061	7.98059	0.00001	-0.043	11.20000
10.4548	8.44764	8.44763	0.00001	-0.019	14.50000
12.1441	8.86558	8.86558	-0.00001	0.025	18.39999
13.8085	9.23397	9.23397	0.00000	-0.001	22.70000
15.4234	9.55779	9.55779	0.00000	-0.003	27.29999
17.0386	9.85436	9.85436	0.00000	-0.008	32.20000
18.6560	10.12893	10.12893	-0.00000	0.003	37.29999
20.2745	10.38564	10.38564	-0.00000	0.019	42.20000
21.8494	10.62190	10.62189	0.00001	-0.035	46.59999
23.3056	10.83136	10.83136	-0.00000	0.034	49.89999
24.5587	11.00666	11.00666	0.00000	-0.023	52.09999
25.5464	11.14260	11.14260	-0.00000	0.006	53.39999
26.2550	11.23931	11.23931	-0.00000	0.020	54.00000
26.6984	11.29962	11.29961	0.00001	-0.049	54.20000
26.9538	11.33429	11.33429	-0.00000	0.029	54.29999
27.1018	11.35438	11.35438	-0.00000	0.025	54.29999
27.2130	11.36947	11.36947	0.00000	-0.023	54.29999

Standard Deviation of R = 0.00114 Percent

Standard Deviation of T = 0.10222 mKelvins

RHODIUM-IRON THERMOMETER B189
12th order

Temperature Kelvins	Resistance Ohms	First Derivative Ohms/K	Second Derivative Ohms/K/K
0.4398	4.29360	0.5906	0.0056
0.5187	4.34024	0.5908	0.0011
0.6498	4.41770	0.5905	-0.0057
0.8510	4.53631	0.5884	-0.0147
1.0283	4.64035	0.5852	-0.0214
1.1827	4.73046	0.5815	-0.0264
1.3096	4.80404	0.5779	-0.0299
1.7221	5.03964	0.5637	-0.0386
2.1715	5.28884	0.5450	-0.0441
2.4800	5.45480	0.5310	-0.0462
3.4140	5.93033	0.4871	-0.0469
4.2219	6.30876	0.4502	-0.0441
4.5034	6.43372	0.4379	-0.0428
5.7630	6.95307	0.3880	-0.0364
7.1998	7.47537	0.3406	-0.0298
8.7851	7.98059	0.2983	-0.0239
10.4548	8.44763	0.2625	-0.0192
12.1441	8.86558	0.2334	-0.0155
13.8084	9.23397	0.2101	-0.0126
15.4234	9.55779	0.1915	-0.0104
17.0386	9.85436	0.1762	-0.0086
18.6560	10.12893	0.1638	-0.0069
20.2745	10.38564	0.1539	-0.0054
21.8494	10.62189	0.1465	-0.0040
23.3056	10.83136	0.1415	-0.0029
24.5587	11.00666	0.1385	-0.0019
25.5464	11.14260	0.1369	-0.0013
26.2550	11.23931	0.1361	-0.0008
26.6984	11.29961	0.1358	-0.0005
26.9538	11.33429	0.1357	-0.0003
27.1018	11.35438	0.1357	-0.0002
27.2130	11.36947	0.1357	-0.0001

RHODIUM-IRON THERMOMETER B189

12th order

Temperature Kelvins	Resistance Ohms	First Derivative Ohms/K	Second Derivative Ohms/K/K
0.5000	4.32918	0.5908	0.0022
1.0000	4.62380	0.5858	-0.0204
1.5000	4.91350	0.5718	-0.0344
2.0000	5.19472	0.5524	-0.0424
2.5000	5.46542	0.5301	-0.0462
3.0000	5.72463	0.5066	-0.0474
3.5000	5.97202	0.4830	-0.0467
4.0000	6.20776	0.4600	-0.0451
4.5000	6.43224	0.4381	-0.0428
5.0000	6.64602	0.4173	-0.0403
5.5000	6.84973	0.3978	-0.0377
6.0000	7.04401	0.3795	-0.0352
6.5000	7.22948	0.3625	-0.0328
7.0000	7.40672	0.3467	-0.0306
7.5000	7.57632	0.3319	-0.0285
8.0000	7.73877	0.3181	-0.0266
8.5000	7.89456	0.3052	-0.0249
9.0000	8.04414	0.2932	-0.0232
9.5000	8.18790	0.2820	-0.0217
10.0000	8.32623	0.2715	-0.0203
10.5000	8.45947	0.2616	-0.0190
11.0000	8.58794	0.2524	-0.0179
11.5000	8.71196	0.2437	-0.0168
12.0000	8.83178	0.2356	-0.0157
12.5000	8.94767	0.2280	-0.0148
13.0000	9.05985	0.2208	-0.0139
13.5000	9.16856	0.2141	-0.0131
14.0000	9.27399	0.2077	-0.0124
14.5000	9.37632	0.2017	-0.0116
15.0000	9.47575	0.1961	-0.0110
15.5000	9.57243	0.1907	-0.0103
16.0000	9.66652	0.1857	-0.0097
16.5000	9.75818	0.1810	-0.0092
17.0000	9.84755	0.1765	-0.0086
17.5000	9.93477	0.1724	-0.0081
18.0000	10.01998	0.1685	-0.0075
18.5000	10.10330	0.1648	-0.0070
19.0000	10.18486	0.1614	-0.0065
19.5000	10.26479	0.1583	-0.0061
20.0000	10.34320	0.1554	-0.0056
20.5000	10.42021	0.1527	-0.0052
21.0000	10.49592	0.1502	-0.0047
21.5000	10.57046	0.1480	-0.0043
22.0000	10.64391	0.1459	-0.0039
22.5000	10.71639	0.1440	-0.0035
23.0000	10.78799	0.1424	-0.0031
23.5000	10.85882	0.1409	-0.0027
24.0000	10.92896	0.1397	-0.0023
24.5000	10.99852	0.1386	-0.0020
25.0000	11.06759	0.1377	-0.0016

RHODIUM-IRON THERMOMETER B189
12th order

Temperature Kelvins	Resistance Ohms	First Derivative Ohms/K	Second Derivative Ohms/K/K
25.5000	11.13624	0.1370	-0.0013
26.0000	11.20457	0.1364	-0.0010
26.5000	11.27264	0.1360	-0.0007
27.0000	11.34056	0.1357	-0.0003
27.5000	11.40841	0.1357	0.0003

6.3.7 The following is an example of a Report of Calibration for an RIRT (the RIRT of sec. 6.3.6) calibrated over the range from 0.65 K to 25 K on the ITS-90.

UNITED STATES DEPARTMENT OF COMMERCE
NATIONAL INSTITUTE OF STANDARDS AND TECHNOLOGY
NATIONAL MEASUREMENT LABORATORY
GAITHERSBURG, MARYLAND 20899

REPORT OF CALIBRATION

International Temperature Scale of 1990 (ITS-90)

Rhodium-Iron Resistance Thermometer
Serial Number B189

Submitted by
NIST - Thermometry Group
Gaithersburg, MD 20899

This resistance thermometer was calibrated by comparison under isothermal conditions with a set of stable reference rhodium-iron resistance thermometers. A table listing thermometer resistance R as a function of temperature T follows. This table constitutes the calibration.

In addition, as a convenience to the user, least-squares polynomial smoothings of the calibration data have been done. The values of the various polynomial coefficients, their standard deviations, and the deviation of the calibration values from the polynomial values are reported. Finally, a table of temperature, resistance, and the first and second derivatives of resistance with respect to temperature has been generated from a selected recommended polynomial.

This thermometer was calibrated using an AC bridge at a frequency of 30 Hz using excitation currents of 0.125 mA below 1 K and 0.25 mA above 1 K. The current was maintained through the thermometer only during the actual time when measurements of its resistance were made.

For the Director,
National Institute of Standards and Technology

Dr. Hratch G. Semerjian
Chief, Chemical Process Metrology Division
Center for Chemical Technology

Test No. 12345
7 May 1990
Purchase Order No. 123456789

* RHODIUM-IRON THERMOMETER B189

* Calibrated for NIST—Thermometry Group

* Calib. on EPT-76, converted to ITS-90

Calibration Current = 0.125, 0.25 mA

Weight = (dT/dR)**2

T(K)	R(ohms)	Weight	I(mA)
: 0.51872	4.340174	2.86	0.125
: 0.64985	4.417578	2.87	0.125
: 0.85100	4.536304	2.89	0.125
: 1.02826	4.640395	2.92	0.25
: 1.18270	4.730482	2.96	0.25
: 1.30961	4.804059	3.00	0.25
: 1.72213	5.039635	3.15	0.25
: 2.17151	5.268860	3.37	0.25
: 2.47994	5.454826	3.55	0.25
: 3.41397	5.930224	4.22	0.25
: 4.22185	6.308779	4.93	0.25
: 4.50328	6.433776	5.21	0.25
: 5.76285	6.953086	6.64	0.25
: 7.19948	7.475341	8.62	0.25
: 8.78469	7.980605	11.2	0.25
: 10.45422	8.447636	14.5	0.25
: 12.14331	8.865576	18.4	0.25
: 13.80738	9.233974	22.7	0.25
: 15.42204	9.557786	27.3	0.25
: 17.03697	9.854363	32.2	0.25
: 18.65405	10.128928	37.3	0.25
: 20.27221	10.385641	42.2	0.25
: 21.84673	10.621898	46.6	0.25
: 23.30253	10.831357	49.9	0.25
: 24.55534	11.006661	52.1	0.25
: 25.54277	11.142596	53.4	0.25

RHODIUM-IRON THERMOMETER B189
 Calibrated for NIST--Thermometry Group
 Calib. on EPT-76, converted to ITS-90

FORTRAN POLYFIT

AN ORTHONORMAL LEAST-SQUARES FITTING OF THE POLYNOMIAL

$$R = \sum_{J=0}^{J=N} A_J T^J, \quad N = P, P+1, P+2, \dots$$

The fitting is done in double-precision arithmetic. The computer is programmed to select the best polynomial fitting from which to generate a table of temperature, resistance, and the first and second derivatives of resistance with respect to temperature. The page listing the coefficients of the selected polynomial is clearly marked at the bottom.

The deviations of each fitted polynomial from the calibration data are given in the columns headed "Delta R" and "Delta T". The first and second derivatives of each fitted polynomial (in terms of the fitted variables) may be given also.

This analysis and the resultant generated table are provided for convenience in interpolating between the calibration points and do not constitute the calibration.

Special comments:

(1) This example includes the fitting results of only the best polynomial fitting. Normally, fitting results for several lower-order polynomial fittings are included for comparison.

(2) The data are weighted by a factor $(dT/dR)^{-2}$.

Table derived from lowest order fit where the ratio of the coefficients to their standard deviations exceeds 2.00 and the absolute value of each delta T is less than 0.20 mK.
 Read in 26 data points, 26 of which used for fit.

RHODIUM-IRON THERMOMETER B189

11th order

Temperature Kelvins	Resistance Ohms	First Derivative Ohms/K	Second Derivative Ohms/K/K
0.5000	4.32904	0.5915	0.0004
1.0000	4.62383	0.5859	-0.0210
1.5000	4.91353	0.5718	-0.0345
2.0000	5.19472	0.5524	-0.0423
2.5000	5.46541	0.5301	-0.0462
3.0000	5.72463	0.5067	-0.0473
3.5000	5.97205	0.4831	-0.0467
4.0000	6.20781	0.4601	-0.0451
4.5000	6.43231	0.4381	-0.0428
5.0000	6.64610	0.4173	-0.0403
5.5000	6.84981	0.3978	-0.0378
6.0000	7.04409	0.3795	-0.0352
6.5000	7.22955	0.3625	-0.0328
7.0000	7.40680	0.3467	-0.0306
7.5000	7.57640	0.3319	-0.0285
8.0000	7.73887	0.3181	-0.0266
8.5000	7.89468	0.3053	-0.0249
9.0000	8.04427	0.2932	-0.0232
9.5000	8.18805	0.2820	-0.0217
10.0000	8.32639	0.2715	-0.0203
10.5000	8.45964	0.2616	-0.0191
11.0000	8.58813	0.2524	-0.0179
11.5000	8.71215	0.2438	-0.0168
12.0000	8.83197	0.2356	-0.0157
12.5000	8.94786	0.2280	-0.0148
13.0000	9.06005	0.2208	-0.0139
13.5000	9.16877	0.2141	-0.0131
14.0000	9.27421	0.2077	-0.0123
14.5000	9.37656	0.2017	-0.0116
15.0000	9.47600	0.1961	-0.0110
15.5000	9.57269	0.1908	-0.0103
16.0000	9.66680	0.1857	-0.0097
16.5000	9.75847	0.1810	-0.0092
17.0000	9.84785	0.1766	-0.0086
17.5000	9.93507	0.1724	-0.0081
18.0000	10.02028	0.1685	-0.0075
18.5000	10.10361	0.1649	-0.0070
19.0000	10.18518	0.1615	-0.0065
19.5000	10.26511	0.1583	-0.0061
20.0000	10.34354	0.1554	-0.0056
20.5000	10.42056	0.1527	-0.0052
21.0000	10.49630	0.1502	-0.0047
21.5000	10.57085	0.1480	-0.0043
22.0000	10.64431	0.1459	-0.0039
22.5000	10.71680	0.1441	-0.0035
23.0000	10.78841	0.1424	-0.0031
23.5000	10.85924	0.1410	-0.0027
24.0000	10.92940	0.1397	-0.0023
24.5000	10.99899	0.1387	-0.0019
25.0000	11.06809	0.1377	-0.0018

RHODIUM-IRON THERMOMETER B189

11th order

Temperature Kelvins	Resistance Ohms	First Derivative Ohms/K	Second Derivative Ohms/K/K
0.5187	4.34011	0.5915	-0.0006
0.6498	4.41765	0.5910	-0.0070
0.8510	4.53631	0.5887	-0.0156
1.0283	4.64038	0.5853	-0.0220
1.1827	4.73049	0.5815	-0.0267
1.3096	4.80407	0.5779	-0.0301
1.7221	5.03965	0.5636	-0.0386
2.1715	5.28882	0.5449	-0.0440
2.4799	5.45477	0.5310	-0.0461
3.4140	5.93032	0.4871	-0.0469
4.2218	6.30878	0.4502	-0.0441
4.5033	6.43374	0.4380	-0.0428
5.7628	6.95308	0.3880	-0.0364
7.1995	7.47536	0.3407	-0.0297
8.7847	7.98059	0.2983	-0.0239
10.4542	8.44765	0.2625	-0.0192
12.1433	8.86558	0.2334	-0.0155
13.8074	9.23396	0.2101	-0.0126
15.4220	9.55779	0.1916	-0.0104
17.0370	9.85437	0.1762	-0.0086
18.6540	10.12892	0.1638	-0.0069
20.2722	10.38564	0.1539	-0.0054
21.8467	10.62190	0.1465	-0.0040
23.3025	10.83135	0.1415	-0.0028
24.5553	11.00666	0.1386	-0.0019
25.5428	11.14260	0.1368	-0.0020

RHODIUM-IRON THERMOMETER B189

Order of fit = 11

Coefficients	Standard Deviation	Ratio
A 0 = 0.40345618512987D+01	0.17203D-03	23452.05
A 1 = 0.58376417022443D+00	0.42964D-03	1358.72
A 2 = 0.16272867175907D-01	0.38192D-03	42.61
A 3 = -0.12918038396758D-01	0.16723D-03	77.25
A 4 = 0.24053622765144D-02	0.41881D-04	57.43
A 5 = -0.27653106063897D-03	0.65102D-05	42.48
A 6 = 0.21609935957482D-04	0.65633D-06	32.93
A 7 = -0.11647874057269D-05	0.43662D-07	26.68
A 8 = 0.42603165622150D-07	0.19026D-08	22.39
A 9 = -0.10088380674519D-08	0.52235D-10	19.31
A10 = 0.13941359214566D-10	0.81948D-12	17.01
A11 = -0.85318387215018D-13	0.56000D-14	15.24

Standard Deviation of Fit = 0.198756E-04 Ohms

T Kelvins	R Ohms	R Calculated Ohms	Delta R Ohms	Delta T mKelvins	Weight
0.5187	4.34017	4.34011	0.00006	-0.105	2.86000
0.6499	4.41758	4.41765	-0.00007	0.116	2.87000
0.8510	4.53630	4.53631	-0.00001	0.018	2.89000
1.0283	4.64040	4.64038	0.00002	-0.026	2.92000
1.1827	4.73048	4.73049	-0.00001	0.019	2.96000
1.3096	4.80406	4.80407	-0.00001	0.021	3.00000
1.7221	5.03964	5.03965	-0.00001	0.019	3.15000
2.1715	5.28886	5.28882	0.00004	-0.069	3.37000
2.4799	5.45483	5.45477	0.00006	-0.104	3.55000
3.4140	5.93022	5.93032	-0.00009	0.187	4.22000
4.2219	6.30878	6.30878	0.00000	-0.005	4.93000
4.5033	6.43378	6.43374	0.00003	-0.074	5.21000
5.7629	6.95309	6.95308	0.00001	-0.017	6.64000
7.1995	7.47534	7.47536	-0.00001	0.044	8.62000
8.7847	7.98061	7.98059	0.00002	-0.054	11.20000
10.4542	8.44764	8.44765	-0.00001	0.038	14.50000
12.1433	8.86558	8.86558	-0.00000	0.020	18.39999
13.8074	9.23397	9.23396	0.00001	-0.055	22.70000
15.4220	9.55779	9.55779	-0.00000	0.015	27.29999
17.0370	9.85436	9.85437	-0.00001	0.041	32.20000
18.6541	10.12893	10.12892	0.00001	-0.035	37.29999
20.2722	10.38564	10.38564	0.00000	-0.011	42.20000
21.8467	10.62190	10.62190	-0.00001	0.039	46.59999
23.3025	10.83136	10.83135	0.00000	-0.033	49.89999
24.5553	11.00666	11.00666	-0.00000	0.015	52.09999
25.5428	11.14260	11.14260	0.00000	-0.003	53.39999

Standard Deviation of R = 0.00081 Percent

Standard Deviation of T = 0.08401 mKelvins

**** THESE COEFFICIENTS SELECTED FOR THE GENERATED TABLE ****

6.3.8 The following is an example of a Report of Calibration for a thermocouple calibrated over the range from 0 °C to 1450 °C.

REPORT OF CALIBRATION

TYPE S THERMOCOUPLE

(Tagged: S/N 2211998)

Submitted by

ZZYYXX Company
Hometown, U.S.A

All temperatures in this report are given in degrees Celsius (ITS-90). The International Temperature Scale of 1990 (ITS-90) was adopted by the International Committee of Weights and Measures at its meeting in September 1989, and is described in "The International Temperature Scale of 1990", *Metrologia* 27, No. 1, 3-10 (1990).

The thermocouple was calibrated by comparison with a standard type S thermocouple in the range 0 °C to 1100 °C. Values above 1100 °C were obtained by extrapolation. The calibration procedure is described in Section 3.1 of the National Institute of Standards and Technology Special Publication 250-35, entitled "NIST Measurement Services: The Calibration of Thermocouples and Thermocouple Materials". The thermocouple was electrically annealed in air before testing.

Table 1 gives corresponding values of the emf of the thermocouple in millivolts and the temperature of its measuring junction in degrees Celsius when the reference junctions are at 0 °C. The uncertainties in the emf values given in the table are estimated not to exceed the equivalent of 0.5 °C in the range 0 °C to 600 °C and the equivalent of 0.7 °C in the range 600 °C to 1100 °C; the uncertainties in the emf values increase above 1100 °C to not more than the equivalent of 2 °C at 1450 °C. These uncertainties are discussed in Section 5.2 of NIST SP 250-35. Table 2 gives the coefficients of the equations that were used to compute the emf values given in table 1. Each equation is valid only within the specified temperature range.

The calibration of a thermocouple may change during use. The magnitude of the change depends upon such factors as the temperature, the length of time, and the conditions under which it is used. Factors affecting the performance of platinum-rhodium versus platinum thermocouples are discussed in NIST SP 250-35 and in "Accurate Thermocouple Thermometry", *High Temperatures - High Pressures* 11, 173-192 (1979). Copies of these documents are available from NIST, Chemical Process Metrology Division, Gaithersburg, MD 20899.

For the Director
National Institute of Standards and Technology

Dr. Hratch G. Semerjian
Chief, Chemical Process Metrology Division
Center for Chemical Technology
National Measurement Laboratory

P.O. No. 123ABC123
Test No. 998877
Date : May 4, 1990

TABLE 1. Values of emf versus temperature for the type S thermocouple

May 4, 1990

NIST Test No. 998877

°C	0	1	2	3	4	5	6	7	8	9
0	0.000	0.005	0.011	0.016	0.022	0.027	0.033	0.038	0.044	0.050
10	0.055	0.061	0.066	0.072	0.078	0.084	0.089	0.095	0.101	0.107
20	0.113	0.119	0.124	0.130	0.136	0.142	0.148	0.154	0.160	0.166
30	0.172	0.178	0.185	0.191	0.197	0.203	0.209	0.216	0.222	0.228
40	0.234	0.241	0.247	0.253	0.260	0.266	0.272	0.279	0.285	0.292
50	0.298	0.305	0.311	0.318	0.324	0.331	0.338	0.344	0.351	0.357
60	0.364	0.371	0.378	0.384	0.391	0.398	0.405	0.411	0.418	0.425
70	0.432	0.439	0.446	0.452	0.459	0.466	0.473	0.480	0.487	0.494
80	0.501	0.508	0.515	0.522	0.529	0.537	0.544	0.551	0.558	0.565
90	0.572	0.579	0.587	0.594	0.601	0.608	0.616	0.623	0.630	0.637
100	0.645	0.652	0.660	0.667	0.674	0.682	0.689	0.696	0.704	0.711
110	0.719	0.726	0.734	0.741	0.749	0.756	0.764	0.772	0.779	0.787
120	0.794	0.802	0.810	0.817	0.825	0.832	0.840	0.848	0.856	0.863
130	0.871	0.879	0.887	0.894	0.902	0.910	0.918	0.925	0.933	0.941
140	0.949	0.957	0.965	0.973	0.981	0.988	0.996	1.004	1.012	1.020
150	1.028	1.036	1.044	1.052	1.060	1.068	1.076	1.084	1.092	1.100
160	1.108	1.117	1.125	1.133	1.141	1.149	1.157	1.165	1.173	1.182
170	1.190	1.198	1.206	1.214	1.223	1.231	1.239	1.247	1.256	1.264
180	1.272	1.280	1.289	1.297	1.305	1.314	1.322	1.330	1.339	1.347
190	1.355	1.364	1.372	1.381	1.389	1.397	1.406	1.414	1.423	1.431
200	1.440	1.448	1.457	1.465	1.474	1.482	1.491	1.499	1.508	1.516
210	1.525	1.533	1.542	1.550	1.559	1.568	1.576	1.585	1.593	1.602
220	1.611	1.619	1.628	1.637	1.645	1.654	1.663	1.671	1.680	1.689
230	1.697	1.706	1.715	1.723	1.732	1.741	1.750	1.758	1.767	1.776
240	1.785	1.794	1.802	1.811	1.820	1.829	1.838	1.846	1.855	1.864
250	1.873	1.882	1.891	1.899	1.908	1.917	1.926	1.935	1.944	1.953
260	1.962	1.971	1.979	1.988	1.997	2.006	2.015	2.024	2.033	2.042
270	2.051	2.060	2.069	2.078	2.087	2.096	2.105	2.114	2.123	2.132
280	2.141	2.150	2.159	2.168	2.177	2.186	2.195	2.205	2.214	2.223
290	2.232	2.241	2.250	2.259	2.268	2.277	2.286	2.296	2.305	2.314

Temperature in degrees Celsius (ITS-90), emf in millivolts, Reference junctions at 0 °C

TABLE 1. Values of emf versus temperature for the type S thermocouple

May 4, 1990

NIST Test No. 998877

°C	Temperature in degrees Celsius (ITS-90), emf in millivolts, Reference junctions at 0 °C									
	0	1	2	3	4	5	6	7	8	9
300	2.323	2.332	2.341	2.350	2.360	2.369	2.378	2.387	2.396	2.405
310	2.415	2.424	2.433	2.442	2.452	2.461	2.470	2.479	2.488	2.498
320	2.507	2.516	2.525	2.535	2.544	2.553	2.562	2.572	2.581	2.590
330	2.600	2.609	2.618	2.628	2.637	2.646	2.656	2.665	2.674	2.684
340	2.693	2.702	2.712	2.721	2.730	2.740	2.749	2.758	2.768	2.777
350	2.787	2.796	2.805	2.815	2.824	2.834	2.843	2.852	2.862	2.871
360	2.881	2.890	2.899	2.909	2.918	2.928	2.937	2.947	2.956	2.966
370	2.975	2.985	2.994	3.004	3.013	3.023	3.032	3.042	3.051	3.061
380	3.070	3.080	3.089	3.099	3.108	3.118	3.127	3.137	3.146	3.156
390	3.165	3.175	3.184	3.194	3.204	3.213	3.223	3.232	3.242	3.251
400	3.261	3.271	3.280	3.290	3.299	3.309	3.319	3.328	3.338	3.347
410	3.357	3.367	3.376	3.386	3.396	3.405	3.415	3.425	3.434	3.444
420	3.454	3.463	3.473	3.483	3.492	3.502	3.512	3.521	3.531	3.541
430	3.550	3.560	3.570	3.579	3.589	3.599	3.609	3.618	3.628	3.638
440	3.647	3.657	3.667	3.677	3.686	3.696	3.706	3.716	3.725	3.735
450	3.745	3.755	3.764	3.774	3.784	3.794	3.803	3.813	3.823	3.833
460	3.843	3.852	3.862	3.872	3.882	3.892	3.901	3.911	3.921	3.931
470	3.941	3.950	3.960	3.970	3.980	3.990	4.000	4.009	4.019	4.029
480	4.039	4.049	4.059	4.069	4.078	4.088	4.098	4.108	4.118	4.128
490	4.138	4.148	4.157	4.167	4.177	4.187	4.197	4.207	4.217	4.227
500	4.237	4.247	4.256	4.266	4.276	4.286	4.296	4.306	4.316	4.326
510	4.336	4.346	4.356	4.366	4.376	4.386	4.396	4.406	4.416	4.426
520	4.435	4.445	4.455	4.465	4.475	4.485	4.495	4.505	4.515	4.525
530	4.535	4.545	4.555	4.565	4.575	4.585	4.595	4.605	4.615	4.625
540	4.635	4.646	4.656	4.666	4.676	4.686	4.696	4.706	4.716	4.726
550	4.736	4.746	4.756	4.766	4.776	4.786	4.796	4.806	4.817	4.827
560	4.837	4.847	4.857	4.867	4.877	4.887	4.897	4.907	4.917	4.928
570	4.938	4.948	4.958	4.968	4.978	4.988	4.999	5.009	5.019	5.029
580	5.039	5.049	5.059	5.070	5.080	5.090	5.100	5.110	5.120	5.131
590	5.141	5.151	5.161	5.171	5.182	5.192	5.202	5.212	5.222	5.233

May 4, 1990

NIST Test No. 998877

TABLE 1. Values of emf versus temperature for the type S thermocouple

Temperature in degrees Celsius (ITS-90), °C	emf in millivolts, Reference junctions at 0 °C									
	0	1	2	3	4	5	6	7	8	9
600	5.243	5.253	5.263	5.273	5.284	5.294	5.304	5.314	5.325	5.335
610	5.345	5.355	5.366	5.376	5.386	5.396	5.407	5.417	5.427	5.438
620	5.448	5.458	5.468	5.479	5.489	5.499	5.510	5.520	5.530	5.541
630	5.551	5.561	5.571	5.582	5.592	5.602	5.613	5.623	5.633	5.643
640	5.654	5.664	5.674	5.685	5.695	5.705	5.716	5.726	5.736	5.747
650	5.757	5.767	5.778	5.788	5.798	5.809	5.819	5.830	5.840	5.850
660	5.861	5.871	5.881	5.892	5.902	5.913	5.923	5.933	5.944	5.954
670	5.965	5.975	5.985	5.996	6.006	6.017	6.027	6.038	6.048	6.058
680	6.069	6.079	6.090	6.100	6.111	6.121	6.132	6.142	6.153	6.163
690	6.174	6.184	6.194	6.205	6.215	6.226	6.236	6.247	6.257	6.268
700	6.278	6.289	6.299	6.310	6.321	6.331	6.342	6.352	6.363	6.373
710	6.384	6.394	6.405	6.415	6.426	6.437	6.447	6.458	6.468	6.479
720	6.489	6.500	6.511	6.521	6.532	6.542	6.553	6.564	6.574	6.585
730	6.596	6.606	6.617	6.627	6.638	6.649	6.659	6.670	6.681	6.691
740	6.702	6.713	6.723	6.734	6.745	6.755	6.766	6.777	6.787	6.798
750	6.809	6.820	6.830	6.841	6.852	6.862	6.873	6.884	6.895	6.905
760	6.916	6.927	6.938	6.948	6.959	6.970	6.981	6.991	7.002	7.013
770	7.024	7.035	7.045	7.056	7.067	7.078	7.089	7.099	7.110	7.121
780	7.132	7.143	7.153	7.164	7.175	7.186	7.197	7.208	7.219	7.229
790	7.240	7.251	7.262	7.273	7.284	7.295	7.306	7.316	7.327	7.338
800	7.349	7.360	7.371	7.382	7.393	7.404	7.415	7.426	7.437	7.447
810	7.458	7.469	7.480	7.491	7.502	7.513	7.524	7.535	7.546	7.557
820	7.568	7.579	7.590	7.601	7.612	7.623	7.634	7.645	7.656	7.667
830	7.678	7.689	7.700	7.711	7.722	7.733	7.744	7.755	7.766	7.777
840	7.789	7.800	7.811	7.822	7.833	7.844	7.855	7.866	7.877	7.888
850	7.899	7.910	7.921	7.933	7.944	7.955	7.966	7.977	7.988	7.999
860	8.010	8.022	8.033	8.044	8.055	8.066	8.077	8.088	8.100	8.111
870	8.122	8.133	8.144	8.155	8.166	8.178	8.189	8.200	8.211	8.222
880	8.234	8.245	8.256	8.267	8.278	8.290	8.301	8.312	8.323	8.334
890	8.346	8.357	8.368	8.379	8.391	8.402	8.413	8.424	8.435	8.447

TABLE 1. Values of emf versus temperature for the type S thermocouple

May 4, 1990

NIST Test No. 998877

°C	emf in millivolts, Reference junctions at 0 °C									
	0	1	2	3	4	5	6	7	8	9
900	8.458	8.469	8.480	8.492	8.503	8.514	8.526	8.537	8.548	8.559
910	8.571	8.582	8.593	8.605	8.616	8.627	8.638	8.650	8.661	8.672
920	8.684	8.695	8.706	8.718	8.729	8.740	8.752	8.763	8.774	8.786
930	8.797	8.808	8.820	8.831	8.842	8.854	8.865	8.876	8.888	8.899
940	8.910	8.922	8.933	8.945	8.956	8.967	8.979	8.990	9.001	9.013
950	9.024	9.036	9.047	9.058	9.070	9.081	9.093	9.104	9.116	9.127
960	9.138	9.150	9.161	9.173	9.184	9.196	9.207	9.218	9.230	9.241
970	9.253	9.264	9.276	9.287	9.299	9.310	9.322	9.333	9.345	9.356
980	9.368	9.379	9.391	9.402	9.414	9.425	9.437	9.448	9.460	9.471
990	9.483	9.494	9.506	9.517	9.529	9.540	9.552	9.563	9.575	9.587
1000	9.598	9.610	9.621	9.633	9.644	9.656	9.668	9.679	9.691	9.702
1010	9.714	9.725	9.737	9.749	9.760	9.772	9.783	9.795	9.807	9.818
1020	9.830	9.842	9.853	9.865	9.876	9.888	9.900	9.911	9.923	9.935
1030	9.946	9.958	9.970	9.981	9.993	10.005	10.016	10.028	10.040	10.051
1040	10.063	10.075	10.086	10.098	10.110	10.122	10.133	10.145	10.157	10.168
1050	10.180	10.192	10.204	10.215	10.227	10.239	10.250	10.262	10.274	10.286
1060	10.297	10.309	10.321	10.333	10.344	10.356	10.368	10.380	10.391	10.403
1070	10.415	10.427	10.439	10.450	10.462	10.474	10.486	10.497	10.509	10.521
1080	10.533	10.545	10.556	10.568	10.580	10.592	10.604	10.616	10.627	10.639
1090	10.651	10.663	10.675	10.686	10.698	10.710	10.722	10.734	10.746	10.758
1100	10.769	10.781	10.793	10.805	10.817	10.829	10.841	10.852	10.864	10.876
1110	10.888	10.900	10.912	10.924	10.936	10.947	10.959	10.971	10.983	10.995
1120	11.007	11.019	11.031	11.043	11.055	11.066	11.078	11.090	11.102	11.114
1130	11.126	11.138	11.150	11.162	11.174	11.186	11.198	11.209	11.221	11.233
1140	11.245	11.257	11.269	11.281	11.293	11.305	11.317	11.329	11.341	11.353
1150	11.365	11.377	11.389	11.401	11.413	11.425	11.437	11.449	11.461	11.473
1160	11.484	11.496	11.508	11.520	11.532	11.544	11.556	11.568	11.580	11.592
1170	11.604	11.616	11.628	11.640	11.652	11.664	11.676	11.688	11.700	11.712
1180	11.724	11.736	11.748	11.760	11.772	11.784	11.797	11.809	11.821	11.833
1190	11.845	11.857	11.869	11.881	11.893	11.905	11.917	11.929	11.941	11.953

TABLE 2. Coefficients of equations used to compute the emf values given in Table 1

May 4, 1990

Type S Thermocouple

NIST Test No. 998877

The equations for computing values of emf as a function of temperature are of the form:

$$E = a_0 + a_1(t_{90}) + a_2(t_{90})^2 + a_3(t_{90})^3 + a_4(t_{90})^4 + a_5(t_{90})^5 + a_6(t_{90})^6 + a_7(t_{90})^7,$$

where E is the emf in millivolts and t_{90} is the temperature in degrees Celsius (ITS-90). The coefficients for the different temperature ranges are:

Temperature Range (°C):	0.0 to 630.615	630.615 to 1064.18	1064.18 to 1450.0
a ₀ =	0.0000000E+00	+7.73978507E+01	+1.27215252E+00
a ₁ =	+5.38855632E-03	-6.74241592E-01	+3.51320947E-03
a ₂ =	+1.25887998E-05	+2.54971184E-03	+6.38382022E-06
a ₃ =	-2.25397617E-08	-5.23907654E-06	-1.57080365E-09
a ₄ =	+2.80969912E-11	+6.40551834E-09	-6.59301056E-16
a ₅ =	-2.06507465E-14	-4.65707083E-12	+0.00000000E+00
a ₆ =	+5.83931408E-18	+1.86462682E-15	+0.00000000E+00
a ₇ =	+1.36600273E-21	-3.17267781E-19	+0.00000000E+00

6.3.9 The following is an example of a Report of Calibration for a liquid-in-glass thermometer calibrated over the range from 0 °C to 100 °C on the IPTS-68(75).

U.S. DEPARTMENT OF COMMERCE
NATIONAL INSTITUTE OF STANDARDS AND TECHNOLOGY
(FORMERLY NATIONAL BUREAU OF STANDARDS)
NATIONAL MEASUREMENT LABORATORY
GAITHERSBURG, MD. 20899

R E P O R T O F C A L I B R A T I O N

LIQUID-IN-GLASS THERMOMETER

TESTED FOR: NATIONAL INSTITUTE OF STANDARDS AND TECHNOLOGY
DIVISION 586

MARKED: SURETY T1

RANGE: -2 TO +102 DEGREES C IN 0.2 DEGREE

THERMOMETER READING	CORRECTION (IPTS-68)**
- .10 C	.10 C
20.00	.05
40.00	-.07
60.00	.01
80.00	-.04
100.00	.00

**ALL TEMPERATURES IN THIS REPORT ARE BASED ON THE INTERNATIONAL PRACTICAL TEMPERATURE SCALE OF 1968, IPTS-68. THIS TEMPERATURE SCALE WAS ADOPTED BY THE INTERNATIONAL COMMITTEE OF WEIGHTS AND MEASURES AT ITS MEETING IN OCTOBER, 1968, AND IS DESCRIBED IN "THE INTERNATIONAL PRACTICAL TEMPERATURE SCALE OF 1968 AMENDED EDITION OF 1975," METROLOGIA 12, NO. 1, 7-17 (1976).

ESTIMATED UNCERTAINTIES IN THE ABOVE CORRECTIONS DO NOT EXCEED 0.05 DEGREE UP TO 102 DEGREES C .

FOR A DISCUSSION OF ACCURACIES ATTAINABLE WITH SUCH THERMOMETERS SEE NATIONAL INSTITUTE OF STANDARDS AND TECHNOLOGY SP 250-23, LIQUID-IN-GLASS THERMOMETER CALIBRATION SERVICE.

IF NO SIGN IS GIVEN ON THE CORRECTION, THE TRUE TEMPERATURE IS HIGHER THAN THE INDICATED TEMPERATURE; IF THE SIGN GIVEN IS NEGATIVE, THE TRUE TEMPERATURE IS LOWER THAN THE INDICATED TEMPERATURE. TO USE THE CORRECTIONS PROPERLY, REFERENCE SHOULD BE MADE TO THE NOTES GIVEN BELOW.

THE TABULATED CORRECTIONS APPLY FOR THE CONDITION OF TOTAL IMMERSION OF THE BULB AND LIQUID COLUMN. IF THE THERMOMETER IS USED AT PARTIAL IMMERSION, APPLY AN EMERGENT STEM CORRECTION AS EXPLAINED IN THE ACCOMPANYING STEM CORRECTION SHEET.

TEST NUMBER 999999
P.O. NO. 99999
COMPLETED 10-3-89

6.3.10 The following is an example of a Report of Calibration for the liquid-in-glass thermometer of section 6.3.9 calibrated over the range from 0 °C to 100 °C on the IPTS-68(75) but converted to the ITS-90.

U.S. DEPARTMENT OF COMMERCE
NATIONAL INSTITUTE OF STANDARDS AND TECHNOLOGY
NATIONAL MEASUREMENT LABORATORY
GAITHERSBURG, MD. 20899

R E P O R T O F C A L I B R A T I O N

LIQUID-IN-GLASS THERMOMETER

TESTED FOR: NATIONAL INSTITUTE OF STANDARDS AND TECHNOLOGY
DIVISION 586

MARKED: SURETY T1

RANGE: -2 TO +102 DEGREES C IN 0.2 DEGREE GRADUATIONS

THERMOMETER READING	CORRECTION (ITS-90)**
- .10 C	.10 C
20.00	.04
40.00	-.08
60.00	-.01
80.00	-.06
100.00	-.03

**ALL TEMPERATURES IN THIS REPORT ARE ON THE INTERNATIONAL TEMPERATURE SCALE OF 1990, ITS-90. THIS TEMPERATURE SCALE WAS ADOPTED BY THE INTERNATIONAL COMMITTEE OF WEIGHTS AND MEASURES AT ITS MEETING IN SEPTEMBER 1989, AND IS DESCRIBED IN "THE INTERNATIONAL TEMPERATURE SCALE OF 1990", METROLOGIA 27, NO. 1, 3-10 (1990).

ESTIMATED UNCERTAINTIES IN THE ABOVE CORRECTIONS DO NOT EXCEED 0.05 DEGREE UP TO 102 DEGREES C .

FOR A DISCUSSION OF ACCURACIES ATTAINABLE WITH SUCH THERMOMETERS SEE NATIONAL INSTITUTE OF STANDARDS AND TECHNOLOGY SP 250-23, LIQUID-IN-GLASS THERMOMETER CALIBRATION SERVICE.

IF NO SIGN IS GIVEN ON THE CORRECTION, THE TRUE TEMPERATURE IS HIGHER THAN THE INDICATED TEMPERATURE; IF THE SIGN GIVEN IS NEGATIVE, THE TRUE TEMPERATURE IS LOWER THAN THE INDICATED TEMPERATURE. TO USE THE CORRECTIONS PROPERLY, REFERENCE SHOULD BE MADE TO THE NOTES GIVEN BELOW.

THE TABULATED CORRECTIONS APPLY FOR THE CONDITION OF TOTAL IMMERSION OF THE BULB AND LIQUID COLUMN. IF THE THERMOMETER IS USED AT PARTIAL IMMERSION, APPLY AN EMERGENT STEM CORRECTION AS EXPLAINED IN THE ACCOMPANYING STEM CORRECTION SHEET.

TEST NUMBER 999999
P.O. NO. 99999
COMPLETED 2-2-90

6.4 The National Conference of Standard Laboratories (NCSL) Ad Hoc Committee (91.3) on the Change in the International Temperature Scale that was formed to publicize the ITS-90 and its implementation and to minimize the confusion and inconvenience of the change from the IPTS-68(75) was as follows.

Dr. B. W. Mangum, Chairman
PHY B128
National Institute of Standards
and Technology
Gaithersburg, MD 20899

Mr. George W. Burns
PHY B128
National Institute of Standards
and Technology
Gaithersburg, MD 20899

Dr. Stanley Abramowitz
CHEM B348
National Institute of Standards
and Technology
Gaithersburg, MD 20899

Dr. George T. Furukawa
PHY B128
National Institute of Standards
and Technology
Gaithersburg, MD 20899

Dr. Richard L. Anderson
Instrumentation and Controls Division
Oak Ridge National Laboratory
Oak Ridge, TN 37830

Mr. Paul D. Levine
Primary Standards Laboratory
O/48-75 B195A
Lockheed Missiles & Space Company
P. O. Box 3504
Sunnyvale, CA 94808

Laurel Auxier, Manager
Corporate Instrumentation and
Measurement Standards
Smith Kline-Beckman,
Beckman Instruments Division
M/S H-02-C
2500 Harbor Boulevard
Fullerton, CA 92634

Dr. Michael R. Moldover
PHY A105
National Institute of Standards
and Technology
Gaithersburg, MD 20899

Mr. Laurie H. Baker
Metrology Engineering
Autonetics Marine Systems Division
Rockwell International
P. O. Box 4921
Anaheim, CA 92803

Mr. Henry Sostmann
2307 Whitley Drive
Durham, NC 27707

Mr. Sidney Ween
Ever Ready Thermometer Co., Inc.
401 Park Avenue South
New York, NY 10022

Mr. Jesse Berlanga
NADEP/NPSD, Code 062
North Island, Building 378
San Diego, CA 92135

Mr. John Wehrmeyer
Eastman Kodak Co.
3rd Floor, Building 69
Rochester, NY 14650-1912

Dr. George N. Bowers
Director, Clinical Laboratories
Hartford Hospital
Hartford, CT 06115

Mr. James Zugel
Boeing Aerospace Co.
Mail Stop 2P-30
P. O. Box 3999
Seattle, WN 98124

Mr. Neil L. Brown
Woods Hole Oceanographic Institution
Woods Hole, Ma 02543

7. NIST Calibration Services, Thermometers

In this appendix, calibration services offered by the Thermometry Group are specified (taken in part from NIST SP 250).

7.1 Laboratory Thermometers

Technical Contact: Jacquelyn A. Wise
Tel: 301/975-4822

Mailing Address: B126 Physics
National Institute of Standards and Technology
Gaithersburg, MD 20899-0001

Shipping Address: National Institute of Standards and Technology
I-270 at Quince Orchard Road
A242 Physics
Gaithersburg, MD 20899-0001

Attn: J.A. Wise

Table 1. Calibration Services

Test No.	Items
31010C	Laboratory Thermometers (0 to 150 °C)(32 to 300 °F)
31020C	Laboratory Thermometers (151 to 300 °C)(301 to 600 °F)
31030C	Laboratory Thermometers (301 to 538 °C)(601 to 1000 °F)
31040C	Laboratory Thermometers (-1 to -110 °C)(31 to -166 °F)
31050C	Laboratory Thermometers (Liquid N ₂)(-196 °C or -320 °F)
31060C	Laboratory Thermometers (Liquid O ₂)(-183 °C or -297 °F)
31070C	Calorimetric Thermometer
31080C	Beckmann Thermometer
31100C	Quantity Tests of Liquid-in-Glass Thermometers
31110S	Special Tests of Thermometers (0 to 150 °C)(32 to 300 °F)
31120S	Special Tests of Thermometers (151 to 300 °C)(301 to 600 °F)
31130S	Special Tests of Thermometers (301 to 538 °C)(601 to 1000 °F)
31140S	Special Tests of Thermometers (-1 to 110 °C)(31 to -166 °F)
31150S	Special Tests of Thermometers (Liquid N ₂)(-196 °C or -320 °F)
31160S	Special Tests of Thermometers (Liquid O ₂)(-183 °C or -297 °F)
31200S	Preliminary Exam or Ineligible Thermometer
31250S	Additional Copy of Report
31260S	Special Thermometry Services, by Prior Arrangement

Laboratory Thermometers (31010C-31100C)

This service provides for the calibration of a variety of thermometers covering the range from -196 to +538 °C (-320 to +1000 °F).

Thermometers belonging to the large and varied group, which may be classed as laboratory or "chemical" thermometers, are regularly accepted. These are of the

liquid-in-glass type with either solid-stem or enclosed scale. Ordinary household or meteorological thermometers will not, in general, be accepted unless the scale is graduated on the glass stem itself and the thermometer can be readily detached from its mounting for insertion in a liquid bath. Every thermometer submitted must be uniquely identified by a serial number and must pass a preliminary examination for fineness and uniformity of graduation; for cleanliness of the mercury and capillary bore; for freedom from moisture, gas bubbles, and cracks in the glass; for adequacy or omission of gas filling where needed; for insufficient annealing; and for misnumbered graduations. When these or other serious defects are found, the thermometer is returned untested.

The thermometers to be calibrated are placed in a constant temperature bath along with a NIST-calibrated standard platinum resistance thermometer (SPRT). The SPRT maintains calibrations traceable to the International Temperature Scale of 1990 (ITS-90) with an uncertainty of about 1 mK. (See table 2.)

Table 2: Thermometer Calibration Uncertainties

Type of Thermometer (Total Immersion)	Range	Uncertainty
Mercury-in-glass (graduations: 0.1-0.2 °C)	0 to 100 °C	0.03 to 0.05 °C
Mercury-in-glass (graduations: 1-2 °C)	0 to 300 °C 300 to 500 °C	0.2 to 0.5 °C 0.5 to 1.0 °C
Organic liquid-in-glass	-200 to 0 °C	0.2 to 0.5 °C

Special Tests of Thermometers (31110S-31160S)

Special tests may be conducted on temperature-measuring devices such as industrial grade platinum resistance thermometers, digital thermometers, and thermistors. Laboratory personnel should be contacted before submitting items.

7.2. Thermocouples, Thermocouple Materials, and Pyrometer Indicators

Technical Contacts: George W. Burns
32010C-32101C, 32150S
Tel: 301/975-4817

Margaret G. Scroger
32010C-32101C, 32150S
Tel: 301/975-4818

Jacquelyn A. Wise
32110C-32147C
Tel: 301/975-4822

Mailing Address: B126 Physics
National Institute of Standards and Technology
Gaithersburg, MD 20899-0001

Shipping Address: National Institute of Standards and Technology
I-270 at Quince Orchard Road
Gaithersburg, MD 20899-0001

For 32010C-32101C, 32150S
[Attn: G.W. Burns or M.G. Scroger, Bldg. 221, Room

B229]

For 32110C-32147C
[Attn: J.A. Wise, Bldg. 221, Room A242]

Comparison Calibrations, Temperature Measured with Reference Thermocouple

Test No.	Items	Temp. Range °C	Points	Min. Length (mm)	Temp. (°C)	Est. Uncert. (°C)
32010C	S	0-1450	1 °C or 1 °F	700	0-600	0.5
		Interv. Table		600 to 1100	0.7 1450	2
32020C	R	0-1450	" " "	700	0 to 600 600 to 1100 1450	0.5 0.7 2
32030C	B	0-1750	" " "	1000	0 to 600 600 to 1100 1450 1750	(3 μV) 0.7 2 3
32031C	B	800-1750	" " "	1000	800 to 1100 1450 1750	0.7 2 3
32040C	E	0-1000	4 to 15	700		1
32041C	J	0-760	4 to 15	700		1
32042C	K	0-1100	4 to 15	700		1
32043C	N	0-1100	4 to 15	700		1
32044C	T	0-400	4 to 15	700		1
32050C	Comparison calibration, two point minimum, per point, for all items above					
32060C	Each additional table of results at 1 °C or 1 °F intervals, for Type S, R, or B at later date					
32061C	Each additional table of results at 1 °C or 1 °F intervals, for Type S, R, or B at time of test					
32070C	Thermocouple materials tested against Pt thermoelectric standard, 4 to 15 points, 700 mm minimum lengths					

Calibration at Metal Freezing Points, Minimum Diameter 0.4 mm, Freezing Point Determination at Au, Ag, Sb and Zn

32090C	S	0-1450	Table, 1 °C or 1 °F	1000	at freezing	0.2
			interv. and equations		points	
			to generate table		0 to 700	0.3
				700 to 1100	0.4	
					1450	2

32091C Type S, freezing point determination, per point, two point minimum

Calibration of Pyrometer Indicators

32100C	Portable Potentiometer, first dial or range					
32101C	Portable Potentiometer, each additional dial or range					

Comparison Calibration of Thermocouples or Thermocouple Materials Tested against Pt Thermoelectric Standard, Temperature Measured with Platinum Resistance Thermometer, Minimum Length 36 Inches, Two Point Minimum

- 32110C Range -110 to +300 °C and Liquid N₂ (-196 °C) or -166 to 600 °F and Liquid N₂ (-320 °F)
- 32120C 301 to 538 °C or 601 to 1000 °F
- 32130C Liquid O₂ (-183 °C) or (-297 °F)

Table at one degree intervals for Type T thermocouple for any of the following options: (The cost of the table will be in addition to the calibration per point covered under fee schedule items numbered 32110C-32130C.)

- 32141C Option 1: Table from -190 to +300 °C (-310 to +572 °F), calibration points at -183, -110, -50, +100, +200, +300 °C
- 32142C Option 2: Table from -190 to +100 °C (-310 to +212 °F), calibration points at -183, -110, -50, +50, +100 °C
- 32143C Option 3: Table from -110 to +300 °C (-166 to +572 °F), calibration points at -110, -50, +100, +200, +300 °C
- 32144C Option 4: Table from -110 to +100 °C (-166 to +212 °F), calibration points at -110, -50, +50, +100 °C
- 32145C Option 5: Table 0 to 300 °C (32 to 572 °F), calibration points at +100, +200, +300 °C
- 32146C Option 6: Table from -110 to 0 °C (-166 to +32 °F), calibration points at -110, -50 °C.
- 32147C Option 7: Table from -190 to 0 °C (-310 to +32 °F), calibration points at -183, -110, -50 °C
- 32150S Special Tests of Thermocouples and Thermocouple Materials

Thermocouples, Thermocouple Materials, and Pyrometer Indicators (32010C-32147C) Calibration services for all commonly used types of thermocouples are provided by NIST from -196 to 1750 °C depending upon the wire or thermocouple type. The thermocouples are calibrated by one or a combination of three general methods, depending on the thermocouple type, the temperature range, and the accuracy required. All three methods provide traceability to the ITS-90. In the first method, thermocouples are calibrated by comparison with a standard thermocouple maintained at NIST. In the second method, thermocouples are calibrated by comparison with a standard platinum resistance thermometer. In the third method, thermocouples are calibrated at three defining temperatures on the ITS-90--the freezing points of Zn, Ag, and Au, as well as at the freezing point of Sb (at about 630.62 °C). Below 0 °C the thermocouple calibration is carried out in a cryostat, while above 0 °C stirred liquid baths, metal freezing-point cells, and electric tube-type furnaces are employed for the calibrations. Vacuum or inert gas furnaces are also available for testing thermocouples.

Only the bare wires are required to perform the thermocouple calibrations. It is preferable not to send insulating and protecting tubes as the rate of breakage of these in shipment is high. If the thermocouple is furnished mounted (as in a protection tube assembly), a nominal charge will be made for dismantling the mounting and the various parts will be returned to the sender without reassembling them. Thermocouple length requirements listed in the appendix are

exclusive of lead wire. Lead wires (for connections) need not be sent with thermocouples. All thermocouple calibration data furnished in reports will be on the basis of a reference junction temperature of 0 °C (32 °F). The calibration results will be given in degrees Celsius or degrees Fahrenheit, as requested by the customer.

The calibration of a thermocouple will not be undertaken if it will likely not yield the specified uncertainty or if it possesses unusual characteristics that would prevent the calibration or test at a reasonable cost. Only unused base-metal thermocouples and thermocouple materials will be accepted for test.

Special Tests of Thermocouples and Thermocouple Materials (32150S).

For requirements not covered by calibrations described above, special arrangements may be made by contacting one of the specified staff members.

7.3 Resistance Thermometry

Technical Contacts: Earl R. Pfeiffer
0.65 K to 84 K
Tel: 301/975-4821

Gregory F. Strouse
83 K to 962 °C
Tel: 301/975-4803

Mailing Address: B126 Physics
National Institute of Standards and Technology
Gaithersburg, MD 20899-0001

Shipping Address: National Institute of Standards and Technology
I-270 at Quince Orchard Road
B04 Physics,
Gaithersburg, MD 20899-0001

Attn: E.R. Pfeiffer or G.F. Strouse

Test No.	Items
33010C	Capsule PRT (13.8 K to 30 °C)
33020C	Capsule PRT (13.8 K to 157 °C)
33030C	Capsule PRT (13.8 K to 232 °C)
33040C	Capsule PRT (54 K to 30 °C)
33050C	Capsule PRT (54 K to 157 °C)
33060C	Capsule PRT (54 K to 232 °C)
33070C	Capsule PRT (84 K to 30 °C) Ar to Ga
33080C	Capsule PRT (84 K to 157 °C) Ar to In
33090C	Capsule PRT (84 K to 232 °C) Ar to Sn
33100C	Capsule PRT (0 °C to 30 °C) TPW to Ga
33110C	Capsule PRT (0 °C to 157 °C) TPW to In
33120C	Capsule PRT (0 °C to 232 °C) TPW to Sn
33130C	Capsule PRT (234 K to 30 °C) Hg to Ga
33140C	Germanium and Rhodium-Iron Resistance Thermometers (0.65 K to 24.6 K)
33150C	Long Stem PRT (83 K to 0 °C) Ar to TPW
33160C	Long Stem PRT (83 K to 30 °C) Ar to Ga
33170C	Long Stem PRT (83 K to 157 °C) Ar to In
33180C	Long Stem PRT (83 K to 232 °C) Ar to Sn
33190C	Long Stem PRT (83 K to 420 °C) Ar to Zn
33200C	Long Stem PRT (83 K to 661 °C) Ar to Al
33210C	Long Stem PRT (234 K to 30 °C) Hg to Ga
33220C	Long Stem PRT (234 K to 157 °C) Hg to In
33230C	Long Stem PRT (234 K to 232 °C) Hg to Sn
33240C	Long Stem PRT (234 K to 420 °C) Hg to Zn
33250C	Long Stem PRT (234 K to 661 °C) Hg to Al
33260C	Long Stem PRT (0 °C to 30 °C) TPW to Ga
33270C	Long Stem PRT (0 °C to 157 °C) TPW to In
33280C	Long Stem PRT (0 °C to 232 °C) TPW to Sn
33290C	Long Stem PRT (0 °C to 420 °C) TPW to Zn
33300C	Long Stem PRT (0 °C to 661 °C) TPW to Al
33310C	Long Stem PRT (0 °C to 962 °C) TPW to Ag
33320C	Additional Copy of Table from Results of 33010C-33310C at Time of Test
33330C	Additional Copy of Table from Results of 33010C-33310C at a Later Date
33340C	Minimum Charge for Unsuitable Thermometer
33350S	Special Tests of Resistance Thermometers
33360S	Special Tests of Thermometric Fixed-Point Devices
33370M	Measurement Assurance Program for Temperature (8 3 K to 420 °C) Ar to Zn
33380M	Measurement Assurance Program for Temperature (83 K to 661 °C) Ar to Al
33390M	Measurement Assurance Program for Temperature (0 °C to 962 °C) Ar to Ag

Resistance Thermometers (33010C-33310C)

NIST provides calibration services for standard platinum resistance thermometers

(SPRTs) from 13.8 K to 1235 K. Both long-stem and capsule-type SPRTs are calibrated, providing direct access to the International Temperature Scale of 1990 (ITS-90). The reproducibility of the calibration measurements of SPRTs is better than 0.3 mK and the total uncertainty of calibration is ± 1 mK at temperatures below 661 °C. The reproducibility increases to about 0.5 mK and the uncertainty to about ± 2 mK at 962 °C. The reproducibility of triple point of water cells used for calibration of SPRTs is ± 50 μ K or better while that for Ar, Hg, Ga, In, Sn, Zn, and Al triple-point or freezing-point cells is 0.1 mK; and that for Ag freezing-point cells is 0.5 mK. Presently, the NIST temperature scale in the range 13.8 K to 84 K is based on stable reference SPRTs of the capsule type that have uncertainties of about ± 0.3 mK down to about 20 K. Below 20 K, the uncertainty degrades to about ± 0.5 mK as the SPRTs become less sensitive. For calibration of rhodium-iron resistance thermometers (RIRTs) and germanium resistance thermometers (GRTs) in the temperature range from 0.65 K to 24.6 K, the NIST scale is based presently on reference standard rhodium-iron resistance thermometers. The uncertainty of those calibrations is about ± 0.3 mK.

To qualify for testing, either long-stem or capsule platinum resistance thermometers must meet two conditions. They must reasonably be expected to meet the requirements of the ITS-90 for a standard interpolating instrument (i.e., a four lead resistor of high-purity platinum hermetically sealed in a protecting tube). Second, they must be compatible with the NIST calibration equipment. It is important that, insofar as possible, resistance thermometers be protected from any mechanical shock that could alter their calibration. For shipment, the thermometer should be softly supported within a case but not be free to rattle. This necessitates the use of packing material that does not become compacted. The thermometer case should, in turn, be softly packed inside a shipping container. The outside shipping container must be sufficiently rigid and strong that it will not appreciably deform under the treatment usually given by common carriers. Styrofoam is not sufficiently rigid to be used as an outside container. Thermometers will not be returned in containers that are obviously unsuitable, such as those closed by nailing. Suitable containers will be provided, for a fee, when a thermometer shipping container is not satisfactory for re-use.

Special Tests of Resistance Thermometers and Special Tests of Thermometric Fixed-Point Devices (33350S and 33360S)

Special tests of various resistance thermometers and thermometric fixed point devices may be obtained by prior arrangement with the specified technical contacts.

Measurement Assurance Program for Temperature (33370M, 33380M, and 33390M)

The purpose of this MAP service is to assure the accuracy of the calibration of temperature standards (83 K to either 420 °C or 661 °C, or 0 °C to 962 °C temperature ranges) made by participating laboratories when using platinum resistance thermometry.

The MAP transport standard consists of a set of three commercial glass-sheathed SPRTs packaged in a special shock-proof shipping container (mechanical shock or

sudden temperature excursions may result in shifts in calibration). These SPRTs are used to assess both the reproducibility and the accuracy of calibrations performed by the participating laboratory.

MAP participants should use the techniques described in NBS Monograph 126 or NBS Special Publication 250-22 and the same fixed points as those used in the NIST calibrations, or use an SPRT previously calibrated by NIST. In order to achieve high accuracy, SPRTs used as standards should be of the matte-finish type to avoid systematic errors arising from light-pipe effects in the glass sheath. The participant must have a triple point of water cell and a calibrated resistance bridge.

After unpacking and inspecting the SPRTs for damage, the participant should measure the resistances of the SPRTs at the triple point of water (using the triple-point cell). This preliminary measurement of the resistances at the triple point of water is used as a "go/no go" check to ensure that the thermometers have not been damaged in shipment.

These preliminary measurements are reported by telephone to NIST; if the values are consistent with the data taken by NIST before shipment, the participant should proceed with further measurements at the fixed points of the ITS-90. NIST provides a worksheet on which the participant should record data. The participant then calculates the thermometer constants from experimental data, records them, and prepares tables of resistance ratio or resistance versus temperature. The SPRTs are recalibrated upon return to NIST and the participant's data are compared with NIST's calibrations. NIST provides a plot of the participating laboratory's temperature deviation from NIST values and a written analysis of the data, including any pertinent observations. In a typical MAP transfer, the participant makes several measurements over a period of one to two months. A typical turnaround time from the date NIST receives the participant's data until a test report is sent to the participant is four to six weeks.

The best NIST SPRT calibrations have precisions of about 0.1 to 0.2 mK. Sources of error that may contribute to the total uncertainty include changes in the calibration of the measurement instruments, changes in the SPRT itself, and uncertainty of the degree of purity of the materials used as fixed-point references (e.g., zinc). As a result of quantifying these errors, NIST currently assigns an uncertainty of 1 mK to the values assigned to the MAP transport standards used below 661 °C. A standards laboratory conscientiously participating in this MAP and having suitable equipment should be able to closely approximate this uncertainty figure. Former participants in the MAP have had uncertainties that ranged from about 1 mK to several tens of millikelvins.

No rigid recommendations can be given concerning how often a participant should utilize the temperature MAP service. Experience has indicated that when temperature measurements are in a state of statistical control, as evidenced by in-house check standards and control charts to monitor the measurement process, the participant(s) should be able to go at least three years between transfers from NIST without significantly degrading the confidence in the correctness of the measurements.

BIBLIOGRAPHIC DATA SHEET

1. PUBLICATION OR REPORT NUMBER NIST/TN-1265
2. PERFORMING ORGANIZATION REPORT NUMBER
3. PUBLICATION DATE August 1990

4. TITLE AND SUBTITLE
Guidelines for Realizing the International Temperature Scale of 1990 (ITS-90)

5. AUTHOR(S)
B. W. Mangum
G. T. Furukawa

6. PERFORMING ORGANIZATION (IF JOINT OR OTHER THAN NIST, SEE INSTRUCTIONS)
U.S. DEPARTMENT OF COMMERCE
NATIONAL INSTITUTE OF STANDARDS AND TECHNOLOGY
GAITHERSBURG, MD 20899

7. CONTRACT/GRANT NUMBER

8. TYPE OF REPORT AND PERIOD COVERED
Final

9. SPONSORING ORGANIZATION NAME AND COMPLETE ADDRESS (STREET, CITY, STATE, ZIP)

Same as item #6

10. SUPPLEMENTARY NOTES

 DOCUMENT DESCRIBES A COMPUTER PROGRAM; SF-185, FIPS SOFTWARE SUMMARY, IS ATTACHED.

11. ABSTRACT (A 200-WORD OR LESS FACTUAL SUMMARY OF MOST SIGNIFICANT INFORMATION. IF DOCUMENT INCLUDES A SIGNIFICANT BIBLIOGRAPHY OR LITERATURE SURVEY, MENTION IT HERE.)
This Technical Note describes the International Temperature Scale of 1990 (ITS-90) that became the official international temperature scale on 1 January 1990, superseding the previous scales, and provides information on how the scale may be realized at different levels of accuracy. The ITS-90 extends upward from 0.65 K, is in close agreement with the Kelvin Thermodynamic Temperature Scale, has much improved continuity, precision and reproducibility throughout its ranges over that of previous scales, and has subranges and alternative definitions in certain ranges that greatly facilitate its use. In addition to a description of the ITS-90 and how it can be realized, there are included in this document reproductions of some articles or excerpts from articles concerned with the ITS-90. The composition of the Comite Consultatif de Thermometrie (CCT) of the Comite International des Poids et Mesures (CIPM) at the time of the adoption of the ITS-90 is given. The differences between the temperatures on the ITS-90 and those on the International Practical Temperature Scale of 1968, Amended Edition of 1975, [IPTS-68(75)] and those on the 1976 Provisional 0.5 K to 30 K Temperature Scale (EPT-76) are tabulated. Measurement procedures for realizing the ITS-90 throughout the various ranges of the scale are given. Also, for the most important temperature region, the region of the platinum resistance thermometer (PRT), computational examples are given for determining the coefficients of the relevant deviation equations for PRTs calibrated at various sets of fixed points. The effects of the introduction of the ITS-90 on electrical reference standards are addressed also.

12. KEY WORDS (6 TO 12 ENTRIES; ALPHABETICAL ORDER; CAPITALIZE ONLY PROPER NAMES; AND SEPARATE KEY WORDS BY SEMICOLONS)
fixed points; ITS-90; International Temperature Scale of 1990; SPRTs; temperature; temperature scale; thermometers; thermometry

13. AVAILABILITY

<input checked="" type="checkbox"/>	UNLIMITED
<input type="checkbox"/>	FOR OFFICIAL DISTRIBUTION. DO NOT RELEASE TO NATIONAL TECHNICAL INFORMATION SERVICE (NTIS).
<input checked="" type="checkbox"/>	ORDER FROM SUPERINTENDENT OF DOCUMENTS, U.S. GOVERNMENT PRINTING OFFICE, WASHINGTON, DC 20402.
<input checked="" type="checkbox"/>	ORDER FROM NATIONAL TECHNICAL INFORMATION SERVICE (NTIS), SPRINGFIELD, VA 22161.

14. NUMBER OF PRINTED PAGES
190

15. PRICE

NIST *Technical Publications*

Periodical

Journal of Research of the National Institute of Standards and Technology—Reports NIST research and development in those disciplines of the physical and engineering sciences in which the Institute is active. These include physics, chemistry, engineering, mathematics, and computer sciences. Papers cover a broad range of subjects, with major emphasis on measurement methodology and the basic technology underlying standardization. Also included from time to time are survey articles on topics closely related to the Institute's technical and scientific programs. Issued six times a year.

Nonperiodicals

Monographs—Major contributions to the technical literature on various subjects related to the Institute's scientific and technical activities.

Handbooks—Recommended codes of engineering and industrial practice (including safety codes) developed in cooperation with interested industries, professional organizations, and regulatory bodies.

Special Publications—Include proceedings of conferences sponsored by NIST, NIST annual reports, and other special publications appropriate to this grouping such as wall charts, pocket cards, and bibliographies.

Applied Mathematics Series—Mathematical tables, manuals, and studies of special interest to physicists, engineers, chemists, biologists, mathematicians, computer programmers, and others engaged in scientific and technical work.

National Standard Reference Data Series—Provides quantitative data on the physical and chemical properties of materials, compiled from the world's literature and critically evaluated. Developed under a worldwide program coordinated by NIST under the authority of the National Standard Data Act (Public Law 90-396). NOTE: The Journal of Physical and Chemical Reference Data (JPCRD) is published quarterly for NIST by the American Chemical Society (ACS) and the American Institute of Physics (AIP). Subscriptions, reprints, and supplements are available from ACS, 1155 Sixteenth St., NW., Washington, DC 20056.

Building Science Series—Disseminates technical information developed at the Institute on building materials, components, systems, and whole structures. The series presents research results, test methods, and performance criteria related to the structural and environmental functions and the durability and safety characteristics of building elements and systems.

Technical Notes—Studies or reports which are complete in themselves but restrictive in their treatment of a subject. Analogous to monographs but not so comprehensive in scope or definitive in treatment of the subject area. Often serve as a vehicle for final reports of work performed at NIST under the sponsorship of other government agencies.

Voluntary Product Standards—Developed under procedures published by the Department of Commerce in Part 10, Title 15, of the Code of Federal Regulations. The standards establish nationally recognized requirements for products, and provide all concerned interests with a basis for common understanding of the characteristics of the products. NIST administers this program as a supplement to the activities of the private sector standardizing organizations.

Consumer Information Series—Practical information, based on NIST research and experience, covering areas of interest to the consumer. Easily understandable language and illustrations provide useful background knowledge for shopping in today's technological marketplace.

Order the above NIST publications from: Superintendent of Documents, Government Printing Office, Washington, DC 20402.

Order the following NIST publications—FIPS and NISTIRs—from the National Technical Information Service, Springfield, VA 22161.

Federal Information Processing Standards Publications (FIPS PUB)—Publications in this series collectively constitute the Federal Information Processing Standards Register. The Register serves as the official source of information in the Federal Government regarding standards issued by NIST pursuant to the Federal Property and Administrative Services Act of 1949 as amended, Public Law 89-306 (79 Stat. 1127), and as implemented by Executive Order 11717 (38 FR 12315, dated May 11, 1973) and Part 6 of Title 15 CFR (Code of Federal Regulations).

NIST Interagency Reports (NISTIR)—A special series of interim or final reports on work performed by NIST for outside sponsors (both government and non-government). In general, initial distribution is handled by the sponsor; public distribution is by the National Technical Information Service, Springfield, VA 22161, in paper copy or microfiche form.

U.S. Department of Commerce
National Institute of Standards and Technology
(formerly National Bureau of Standards)
Gaithersburg, MD 20899

Official Business
Penalty for Private Use \$300