

**NIST**

**United States Department of Commerce**  
National Institute of Standards and Technology



A11103 398656



*NIST Special Publication 780*

---

*Guidelines for  
Pressure Vessel  
Safety Assessment*

*Sumio Yukawa*

---

QC  
100  
.U57  
#780  
1990  
C.2



00150  
US7  
NO 780  
1990  
22

*NIST Special Publication 780*

---

# *Guidelines for Pressure Vessel Safety Assessment*

---

Sumio Yukawa

Materials Reliability Division  
Materials Science and Engineering Laboratory  
National Institute of Standards and Technology  
Boulder, CO 80303

Sponsored by  
Occupational Safety and Health Administration  
U.S. Department of Labor  
Washington, DC 20210

Issued April 1990



**U.S. Department of Commerce**  
Robert A. Mosbacher, Secretary

**National Institute of Standards and Technology**  
John W. Lyons, Director

---

National Institute of Standards  
and Technology  
Special Publication 780  
Natl. Inst. Stand. Technol.  
Spec. Publ. 780  
75 pages (Apr. 1990)  
CODEN: NSPUE2

U.S. Government Printing Office  
Washington: 1990

For sale by the Superintendent  
of Documents  
U.S. Government Printing Office  
Washington, DC 20402

CONTENTS

	<u>Page</u>
ABSTRACT . . . . .	vii
1. INTRODUCTION . . . . .	1
2. SCOPE AND GENERAL INFORMATION . . . . .	1
2.1 Scope . . . . .	1
2.2 General Considerations . . . . .	3
3. PRESSURE VESSEL DESIGN . . . . .	4
3.1 ASME Code . . . . .	4
3.1.1 Section VIII of ASME Code . . . . .	5
3.1.2 Scope of Section VIII . . . . .	5
3.1.3 Summary of Design Rules and Margins . . . . .	6
3.1.4 Implementation of ASME Code . . . . .	9
3.2 API Standard 620 . . . . .	10
3.2.1 Scope of API 620 . . . . .	12
3.2.2 Design Rules . . . . .	12
3.2.3 Implementation of API 620 . . . . .	12
3.3. Remarks on Design Codes . . . . .	14
4. DETERIORATION AND FAILURE MODES . . . . .	14
4.1 Preexisting Causes . . . . .	14
4.1.1 Design and Construction Related Deficiencies. . . . .	14
4.1.2 Brittle Fracture . . . . .	15
4.2 Inservice Deterioration and Damage . . . . .	16
4.2.1 General Material Loss . . . . .	16
4.2.2 Localized Attack and Cracking . . . . .	17
4.2.3 Material Property Degradation . . . . .	22
5. INSPECTION METHODS AND IMPLEMENTATION . . . . .	22
5.1 Role of Organization Involved . . . . .	23
5.1.1 ASME Code . . . . .	23
5.1.2 API Standards . . . . .	24
5.1.3 National Board . . . . .	24
5.1.4 ASNT Recommended Practice . . . . .	25
5.1.5 ASTM Specifications . . . . .	25
5.1.6 NACE Recommended Practices . . . . .	25

	<u>Page</u>
5.2 Examination Methods . . . . .	27
5.2.1 Visual Examination (VT) . . . . .	27
5.2.2 Liquid Penetrant Test (PT) . . . . .	27
5.2.3 Magnetic Particle Test (MT) . . . . .	29
5.2.4 Radiography (RT) . . . . .	32
5.2.5 Ultrasonic Testing (UT) . . . . .	32
5.3 Detection Probabilities and Flaw Sizing . . . . .	35
6. RECENT CRACKING EXPERIENCE IN PRESSURE VESSELS . . . . .	36
6.1 Deaerator Service . . . . .	36
6.2 Amine Service . . . . .	39
6.3 Wet Hydrogen Sulfide Service . . . . .	40
6.4 Ammonia Storage Service . . . . .	42
6.5 Pulp Digester Service . . . . .	42
6.6 Summary of Service Cracking Experience . . . . .	44
7. PERIODIC INSPECTION REQUIREMENTS AND RECOMMENDATIONS . . . . .	45
7.1 National Board Inspection Code and API 510 . . . . .	45
7.2 Recommendations for Specific Applications . . . . .	45
7.3 Institute of Petroleum Code . . . . .	47
8. DAMAGE AND CRACK SEVERITY EVALUATION AND REPAIR . . . . .	47
8.1 Damage Evaluation . . . . .	47
8.2 Repair by Welding . . . . .	47
9. INFORMATION FOR SAFETY ASSESSMENT . . . . .	50
10. ACKNOWLEDGMENT . . . . .	50
11. REFERENCES . . . . .	54
APPENDIX A - ASME CODE SECTION VIII, DIVISION 1 REPORT FORM . . . . .	57-58
APPENDIX B - REPORT CONTENT FOR API STANDARD 620 LOW PRESSURE STORAGE TANK . . . . .	59
APPENDIX C - NACE AMINE CRACKING SURVEY QUESTIONNAIRE . . . . .	60-62
APPENDIX D - INSPECTION PRIORITIES FOR WET H <sub>2</sub> S CRACKING SURVEY . . . . .	63
APPENDIX E - NATIONAL BOARD'S INSPECTION REPORT FORM . . . . .	64
APPENDIX F - API 510 REPORT FORM FOR INSPECTION RESULTS . . . . .	65
APPENDIX G - INSTITUTE OF PETROLEUM CODE FREQUENCY OF PERIODIC INSPECTION . . . . .	66
APPENDIX H - NATIONAL BOARD REPORT FORM FOR WELD REPAIR OR ALTERATION	67

## LIST OF FIGURES

		<u>Page</u>
Figure 1.	Illustration of some major parts of a pressure vessel . . . . .	2
Figure 2.	Examples of acceptable nozzle-to-shell welds in Section VIII, Div. 1 of the ASME Code . . . . .	8
Figure 3.	Marking of ASME Section VIII pressure vessels . . . . .	11
Figure 4.	Marking of low pressure storage tanks constructed in accordance with API Standard 620 . . . . .	13
Figure 5.	Illustration of non-branching and branching stress corrosion cracks . . . . .	20
Figure 6.	Concept of threshold stress or stress intensity factor ( $K_{ISCC}$ ) in stress corrosion cracking . . . . .	21
Figure 7.	Appearance of hydrogen induced blisters in carbon steel.	23
Figure 8.	Principles and application of magnetic particle testing.	30
Figure 9.	Illustration of magnetic particle indications due to various causes . . . . .	31
Figure 10.	Longitudinal and shear waves utilized in ultrasonic examination . . . . .	33
Figure 11.	Principles of pulse-echo ultrasonic technique . . . . .	33
Figure 12.	Basic features of angle beam ultrasonic examination of a butt weld . . . . .	34
Figure 13.	Simplified flow diagram for feedwater deaerator/storage system . . . . .	37
Figure 14.	Simplified process flow diagram of amine plant . . . . .	39
Figure 15.	U.S. and European Guidelines for ammonia storage vessels	43
Figure 16.	National Board Stamp or Nameplate for a weld repaired vessel . . . . .	49

LIST OF TABLES

		<u>Page</u>
Table I	SUMMARY OF ASNT RECOMMENDED PRACTICE SNT-TC-1A "QUALIFICATION AND CERTIFICATION PROGRAM FOR NDE PERSONNEL" . . . . .	26
Table II	SUMMARY OF NDE METHODS . . . . .	28
Table III	SUMMARY OF INSPECTION GUIDELINES AND RECOMMENDATIONS . . .	46
Table IV	SUMMARY OF NBIC AND API REPAIR WELDING REQUIREMENTS . . .	48
Table V	INFORMATION AND DATA USEFUL FOR THE SAFETY ASSESSMENT OF STEEL VESSELS AND LOW PRESSURE STORAGE TANKS . . . . .	51



## ABSTRACT

This document presents a technical overview and information on metallic pressure containment vessels and tanks. The intent of the document is to provide OSHA (Occupational Safety and Health Administration) personnel and other persons with information to assist in the evaluation of the safety of operating pressure vessels and low pressure storage tanks.

The scope is limited to general industrial application vessels and tanks constructed of carbon or low alloy steels and used at temperatures between -75 and 315 °C (-100 and 600 °F). Information on design codes, materials, fabrication processes, inspection and testing applicable to these vessels and tanks are presented. The majority of these vessels and tanks are made to the rules and requirements of ASME Code Section VIII or API Standard 620.

The causes of deterioration and damage in operation are described and methods and capabilities of detecting serious damage and cracking are discussed. Service experience in several applications where 30 to 50% incidence of cracking has been found is described. Guidelines and recommendations formulated by various groups to inspect for the damages being found and to mitigate the causes and effects of the problems are presented.

A summary of the needed or useful information for the various factors and items involved in the safety of these vessels and tanks is included to assist in deciding whether further technical evaluation of safety concerns is required.

Key Words: API Standards; ASME Code; design; failure; guidelines; inservice examination; nondestructive testing; pressure vessels; reliability; safety; service experience; steel.



# GUIDELINES FOR PRESSURE VESSEL SAFETY ASSESSMENT

Sumio Yukawa

## 1. INTRODUCTION

This document presents a technical overview and information on pressure vessels and low pressure storage tanks. This overview and information are intended to help identify potentially hazardous conditions and to assist in the evaluation of safety for continued operation. The vessels and tanks of concern are relatively large metallic containers used to contain liquids and gases at various temperatures and pressures.

This document has been prepared primarily for use by the Occupational Safety and Health Administration (OSHA) of the Department of Labor. The purpose of the document is to provide OSHA personnel and other interested persons with background and current technical information regarding the operational reliability and safety of pressure vessels and tanks. This will aid in deciding whether additional engineering evaluation to assess continued safe operation is warranted.

Although pressure vessels designed and constructed to one of the recognized design codes have had an excellent safety record, some recent events indicate a basis for concern about continuing reliability and safety, especially when coupled with the current trend of extending service usage. Recent inspection programs for vessels in several types of applications have revealed cracking and damage in a considerable number of the vessels inspected. These results are discussed in detail later in this document.

## 2. SCOPE AND GENERAL INFORMATION

### 2.1 Scope

Pressure vessels are produced and used in a wide variety of geometrical shapes, capacities, and sizes for use in a large number of applications. Examples range from relatively small and simple air compressor tanks to very large and extremely complex nuclear reactor pressure vessels. The scope of this document might be termed the "mid-segment" of this total application range. Figure 1 illustrates a schematic pressure vessel with some of the main features and terminology.

More specifically, the type and applications of pressure vessels addressed in this document are characterized by the following features:

- Stationary and unfired,
- Used for pressure containment of gases and liquids,
- Constructed of carbon steel or low alloy steel, and
- Operated at temperatures between about -75 and 315 °C (-100 and 600 °F).

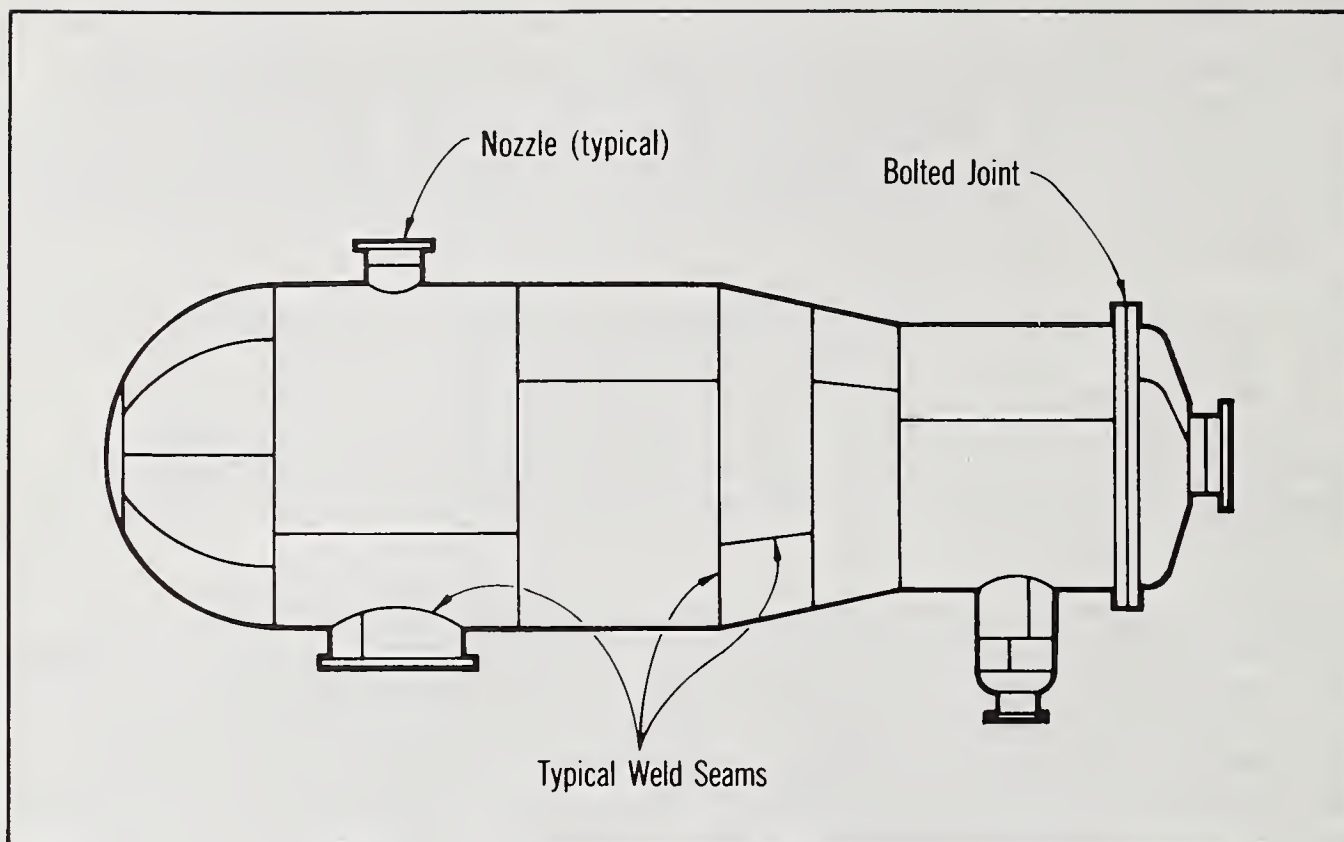

Figure 1. Illustration of some major parts of a pressure vessel.

This definition includes pressure vessels and low pressure storage tanks widely used in process, pulp and paper, petroleum refining, and petrochemical industries and for water treatment systems of boilers and steam generation equipment. (In this document, the term "pressure vessel" generally will be meant to include low pressure storage tanks.)

This scope categorization excludes vessels and tanks used in many other applications and also excludes other parts of a pressure containment system such as piping and valves. Some of the major applications and items not covered in this document because of this scope limitation are:

- Vessels used as fired boilers,
- Vessels used in high temperature processes (above 315 °C, 600 °F) or at very low and cryogenic temperatures,
- Vessels and containers used in transportable systems,
- Storage tanks that operate at nominally atmospheric pressure,
- Piping and pipelines,
- Safety and pressure relief valves, and
- Special purpose vessels, such as those for human occupancy.

## 2.2 General Considerations

Safety and hazard evaluations of pressure vessels need to consider the consequences of a leakage or a rupture failure of a vessel. Hammer [1] in one chapter of his book discusses "Pressure Hazards" and describes two consequences of a complete rupture. One is the blast effect due to sudden expansion of the pressurized fluid. The second consequence is damage and injury caused by fragments if fragmentation type rupture occurs. For a leakage failure, the hazard consequences can include the whole range from no effect to very serious. If the leakage occurs into a closed space, suffocation or poisoning can occur depending on the nature of the contained fluid. Physical consequences include fire and explosion for a flammable fluid.

It is of interest to put some perspective on the potential human hazards arising from pressure vessel operation. The National Board of Boiler and Pressure Vessel Inspectors collects and publishes an annual incident report [2] for pressure vessels (and also a separate report for boilers) within its jurisdictional scope. The number of injuries and deaths attributable to pressure vessel failures over the past few years were as follows:

<u>Year</u>	<u>Injuries</u>	<u>Deaths</u>
1984	437	73
1985	269	78
1986	99	44
1987	44	5

These figures cover all types of pressure vessels, not just the category covered in this document, and include tens of thousands of vessels in operation. There are some limitations on the figures listed above in that reporting of the incidents is voluntary and generally for vessels registered with the National Board. Some less serious incidents or those not involving injuries or fatalities may not be reported. Also, some incidents may not involve the pressure vessel per se but an associated part such as the piping or a relief valve.

In spite of the limitations, the figures indicate a very good overall record. However, recent experience indicates an apparent trend of increasing

deterioration and problems with pressure vessel reliability in some specific types of service. These concerns have derived in part from some serious failures such as the one in 1984 at a petroleum refinery; this failure resulted in an explosion, a fire, and 17 fatalities [3]. Surveys of vessels in several specific applications indicate deterioration and cracking problems greater than expectations; these survey results are described in detail later in section 6.

### 3. PRESSURE VESSEL DESIGN

Most of the pressure or storage vessels within the scope of this document and currently in service in the United States have been designed and constructed in accordance with one of the following two design codes:

- Section VIII of the ASME (American Society of Mechanical Engineers) Boiler and Pressure Vessel Code, commonly referred to as the ASME Code [4], or
- API (American Petroleum Institute) Standard 620 [5].

In addition, some vessels designed and constructed between 1934 to 1956 may have used the rules in the "API-ASME Code for Unfired Pressure Vessels for Petroleum Liquids and Gases." This code was discontinued in 1956.

A summary description of the scope and major features of the ASME Code, Section VIII, and API 620 are presented in the following; the descriptions are limited, and the design codes should be consulted for all detailed information.

There are codes and standards for many of the other applications, components, and parts listed earlier that are not within the scope of this document. These include other Sections of the ASME Code, API Standards, ANSI (American National Standards Institute) Piping Codes, and governmental agency rules.

#### 3.1 ASME Code

The first edition of the ASME Code was the 1914 edition developed and published in response to an appeal to the ASME from manufacturers and users of steam boilers "...to formulate standard specifications for the construction of steam boilers and other pressure vessels and for their care in service." Over the intervening years, this Code has grown in scope and coverage so that the 1986 edition contains 11 Sections and occupies several feet of shelf space. Chuse's book [6] provides an informative description of the history of the ASME Code and the role of various groups involved in its implementation. In addition, it discusses the technical considerations for various applications. A shorter general description of the main features of the Code is available in Yokell's paper [7]. Both of these references also discuss the legal and jurisdictional aspects of the ASME Code.

Of the 11 Sections in the ASME Code, three are concerned with heating and power boilers and two are concerned with pressure containment components for nuclear power plants. Rules for pressure vessels for general applications are contained in Section VIII which is the Section of primary relevance for vessels in the scope of this document. In addition, three other Sections of the Code

have associated relevance since they contain additional rules and requirements which are invoked in Section VIII by reference. These three are:

- Section II, Material Specifications,
- Section V, Nondestructive Examination, and
- Section IX, Welding and Brazing Qualifications.

Reference to these Sections are made at appropriate points in this document.

### 3.1.1 Section VIII of ASME Code

This Section contains the rules for the design, fabrication, inspection, and testing of pressure vessels for general application and covers the following features and items:

- List of acceptable materials,
- Allowable design stresses for the listed materials,
- Design rules and acceptable design details,
- Acceptable forming, welding, and other fabrication methods,
- Bolting materials and design,
- Inspection and testing requirements, and
- Requirements for pressure relief devices.

Section VIII consists of two Divisions, 1 and 2. Vessels for moderate pressures and temperatures and therefore thinner walls (up to about 50 to 75 mm, 2 to 3 in) are usually made to Division 1 requirements while Division 2 is used for higher pressures and temperatures or more severe duty vessels. The alternative rules of Division 2 require more design analysis but permit higher design stresses. The higher design cost is often offset by a decrease in the amount of material used.

### 3.1.2 Scope of Section VIII

The rules of Section VIII, Division 1 do not apply for certain applications and circumstances; of these, several of the more pertinent are:

- Fired process tubular heaters,
- Pressure containers which are integral parts of rotating or reciprocating machinery or which serve as hydraulic or pneumatic cylinders,
- Piping systems and piping components,

- Small hot water supply storage tanks, and
- Vessels of any size having an internal or external operating pressure less than 0.1 MPa (15 psi).

Division 2 of Section VIII has essentially the same limitations on the scope of application.

### 3.1.3 Summary of Design Rules and Margins

The following discussion concentrates on the design basis and rules of Division 1 since it is the more general purpose and widely used part of Section VIII of the ASME Code.

The Code lists a large number of acceptable materials covered by specifications with either SA- or SB- prefix for base materials and SFA- prefix for weld filler materials. The chemical composition, manufacturing methods, and minimum properties specifications for each material are given in Section II of the Code. The ferrous metal alloys (carbon, low alloy, high alloy stainless, and heat resisting steels) are in the SA- group and the nonferrous metal alloys (aluminum, copper, nickel, and titanium alloys) are in the SB- group. In most cases, the SA- and SB- specifications are identical to or nearly identical to the numerically corresponding ASTM (American Society of Testing and Materials) A- or B- specifications, and the SFA- specifications are identical to the AWS (American Welding Society) A- specifications.

Section VIII has approved for use most but not all of the materials listed in Section II. In ASME Code terminology, the term "low alloy steel" includes steels containing up to 9% chromium (Cr) and 1% molybdenum (Mo). However, the temperature range addressed in this document puts a practical maximum of around 3% total alloy content (for example, 2.25 Cr-1 Mo) as the highest alloy content alloy steel likely to be considered. A typical ASME Code specification is SA516-Grade 70 which defines a C-Mn plate steel often used for pressure vessel construction (and is identical to ASTM A516-Grade 70 but with ASME Code verification).

The overall design approach of the ASME Code is to provide an adequate and safe margin against a bursting failure of the pressure vessel at the design pressure. Experimental studies have shown that the bursting failure pressure of vessels is strongly related to the tensile strength of the vessel material. This is valid as long as the strength properties are only temperature dependent but not time dependent, that is, below the temperature where the material strength properties are affected by creep. For the temperature range and materials of concern in this document, time dependent creep strength is not a design consideration.

For Section VIII, Division 1 materials at temperatures above -29 °C (-20 °F) and below the creep range, the maximum allowable design stress is established as follows:



- For -29 to 38 °C (-20 to 100 °F), the lesser of one-fourth of the specified minimum tensile strength or two-thirds of the specified minimum yield strength at room temperature.
- Above 38 °C (100 °F), the lesser of one-fourth of the tensile strength or two-thirds of the yield strength at the elevated temperature.

For most of the carbon and low alloy steels used in Division 1, the allowable stress is governed by the tensile strength criterion. The yield strength criterion is included to prevent excessive distortion of the vessels made from materials that can have a very low yield strength relative to the tensile strength. Based on these criteria, Section VIII, Division 1 pressure vessels can ideally be expected to have a margin of four or greater between the allowable design pressure and the expected bursting failure pressure. This is based on experimental results that the failure strength of a simple pressurized cylinder is approximately equal to the tensile strength of the material.

This margin can be decreased or diminished by several factors:

- Welds and other types of joints,
- Nozzles and other penetrations through the vessel wall which act as stress raisers,
- Brackets, supports, and other geometrical details which may be attached by welding and become a stress raiser, and
- Cracks and other material damage which may be initially present or develop with use.

The Code minimizes the effects of the first three factors by providing rules for acceptable designs and by specific limitations. Welds, especially in conjunction with nozzles and openings, are locations of special concern and the Code prescribes acceptable designs; figure 2 illustrates a few of many acceptable designs.

The inspection requirements for materials and the inspection and postweld heat treatment requirements for welds minimize the effects of the fourth factor in the as-fabricated condition. This is further enhanced by the hydrostatic test (or an alternative pneumatic test) performed after completion of manufacture where successful performance indicates an absence of a serious defect or crack-like discontinuity. Additionally, the increased notch toughness requirements very recently added to Section VIII, Division 1 in the 1987 Addenda to the Code will provide further protection against the effects of cracks and discontinuities. The main features and the rationale for the new toughness rules are discussed by Selz [8]. Very briefly, the new rules consist of exemption curves as a function of thickness for various groups of steels and Charpy impact test requirements for steels not included in the exemption curves.

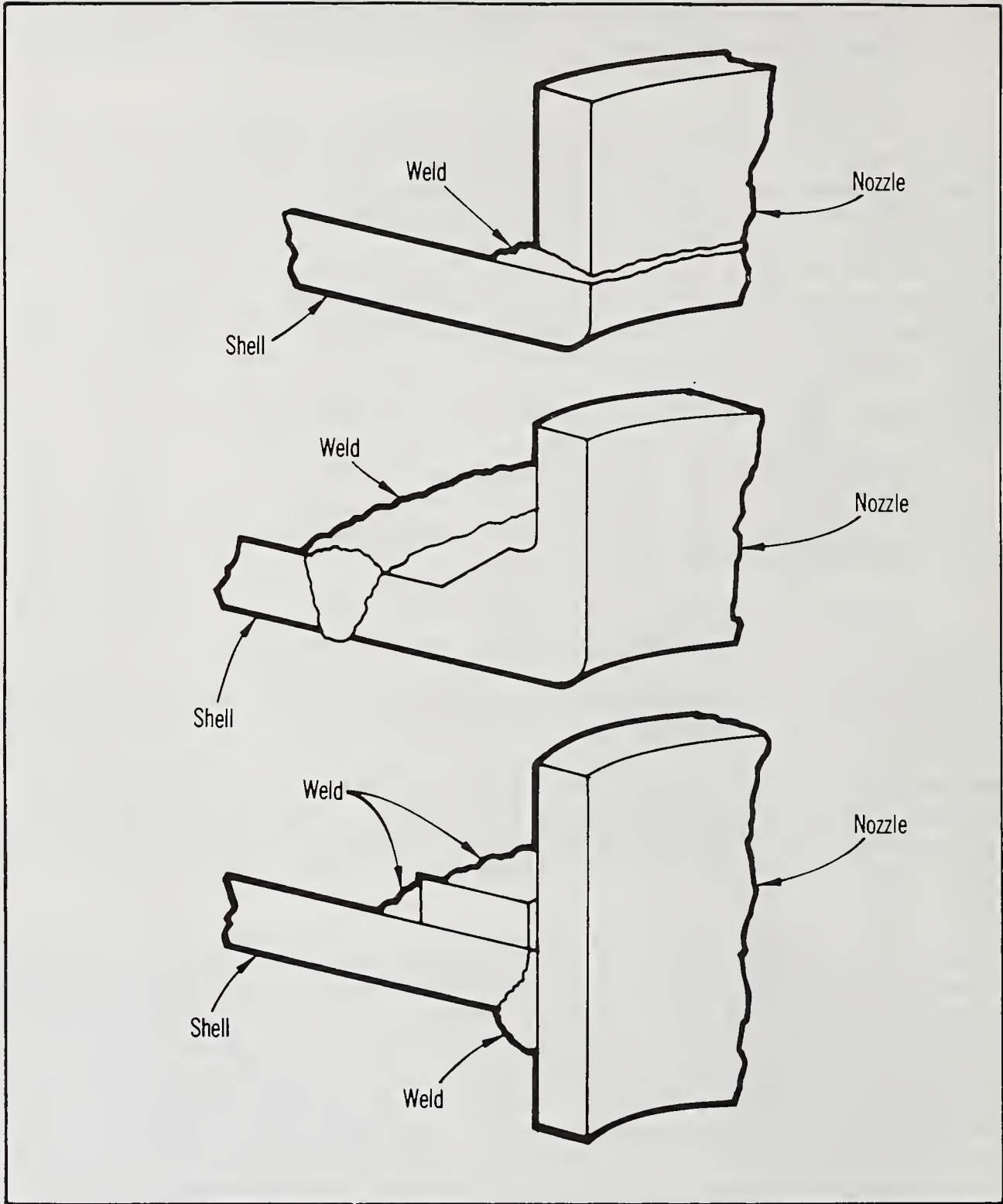

Figure 2. Examples of acceptable nozzle-to-shell welds in Section VIII, Division 1 of the ASME Code.

The fabrication rules in Section VIII include requirements for identifying each major material stock, and rules and tolerances for the cutting and forming. For welded construction, preheat and postweld heat treatment requirements are specified. In addition, a written welding procedure specification (WPS) and qualification of the procedure and the welders who will use the procedure are required. These specification and qualification requirements are prescribed in Section VIII, but the details of their preparation and execution are referred to and provided in another Section of the Code. The intent of these requirements is to ensure that the margin against failure is not diminished below an acceptable value.

The inspection rules of Section VIII include performance requirements and acceptance standards for nondestructive examination (NDE) of materials and fabrication welds. Similar to the welding format, the NDE requirements are prescribed in Section VIII, but the details of the techniques are contained in another Section.

The other important part of the inspection rules concerns the hydrostatic or, alternatively, the pneumatic pressure test. The standard hydrostatic test requirement of Section VIII, Division 1 is pressurization to 1.5 times the maximum allowable working pressure (MAWP), which is usually the same as the design pressure. The rules provide an alternative pneumatic pressure test procedure when a hydrostatic test is not possible or practical. The purpose of the overpressure test is to ensure the overall structural integrity and leak tightness of the pressure vessel. The factor of 1.5 implies that the operating pressure will not be greater than  $2/3$  of a test pressure that the pressure vessel has satisfactorily survived in the final fabricated condition.

For pressure relief and safety valves, Section VIII specifies the performance requirements but does not include detailed requirements for design and testing.

Section VIII is a design and construction code. As such, it does not explicitly have provisions regarding maintenance of the safety margin in service. It does require that the design include a corrosion allowance (increased thickness) to account for material wastage from general corrosion. However, provisions for periodic inspections or evaluations of any other form of deterioration are not included in Section VIII rules.

#### 3.1.4 Implementation of ASME Code

By itself, the ASME Code has no legal standing. However, the Code has been adopted wholly or in part by most States and many cities and other jurisdictions in the United States, and by all the Provinces of Canada. The jurisdictional implementation is accomplished through legislative action by a governing body requiring that pressure vessels for use within its jurisdiction must comply with the ASME Code rules.

The enforcement of the legal requirement is the responsibility of designated officials in the jurisdiction. Since the vessels are often manufactured in a jurisdiction other than where it will be installed, reciprocity is desirable. For this and other reasons, the chief inspectors of

applicable states and large cities in the U.S. and Canadian provinces formed the National Board of Boiler and Pressure Vessel Inspectors, often referred to as the "National Board." This is an independent, non-profit organization that promotes the adoption and use of uniform set of rules and requirements in all of the jurisdictions and reciprocity between jurisdictions. The reciprocity is now common so that manufacture in one location and installation in another is usually possible.

The ASME has certain procedural requirements to ensure that a manufacturer is capable of making vessels to the applicable Code rules and to verify that the material, design, fabrication, and examination requirements are fulfilled. These actions in the case of Section VIII include:

- Certification permitting the Manufacturer to build ASME vessels; this certification is issued after a review verifying the Manufacturer's capability.
- Third party inspection and verification that all requirements have been fulfilled for each vessel.
- Marking of each vessel with the official ASME stamp and the preparation of a Data Report for the vessel.

The Official ASME stamps and the information required to be in the permanent stampings on the vessel for Section VIII, Divisions 1 and 2 vessels are shown in figure 3. A Data Report form for a Division 1 vessel is attached in Appendix A to this document showing the information required.

Several additional details about the marking and Data Report can be noted. If the third party inspection is done by an inspector who holds a National Board Commission, the vessel can also be registered with the National Board. In the case of a vessel to be owned and used by the vessel manufacturer, the third party inspection can be done by an inspector in the manufacturer's employ. For a class of smaller vessels, the "UM" stamp may be used (not included in fig. 3). These vessels have fewer inspection requirements, and the Data Report (Appendix A) is not required; instead, a Certificate of Compliance form is used.

### 3.2 API Standard 620

One of the limitations of Section VIII, Division 1 of the ASME Code is that it does not apply to vessels with an internal pressure less than 0.1MPa (15 psig). American Petroleum Institute's (API) Standard 620, "Recommended Rules for Design and Construction of Large, Welded, Low-Pressure Storage Tanks" [5] provides rules for lower pressure vessels not covered by the ASME Code. For tanks that operate at nominally atmospheric pressure, another API Standard (API 650, "Welded Steel Tanks for Oil Storage") applies.

There are many similarities between API 620 and Section VIII, Division 1 of the ASME Code; the following describes the major differences.

	Certified by
	_____
	Name of Manufacturer
	_____ psi at _____ °F (Max. allowable working pressure)
	_____ °F at _____ psi (Min. design metal temperature)
W (if arc or gas welded)	_____
RT (if radiographed)	(Manufacturer's serial number)
HT (if postweld heat treated)	_____
	(Year built)

Division 1 Vessels

	Certified by
	-----
	(Name of manufacturer)
	----- psi at ----- °F (Design pressure)
	----- °F (Min. permissible temperature)
HT (if postweld heat treated)	-----
	(Manufacturer's serial number)
	-----
	(Year built)

Division 2 Vessels

Figure 3. Marking of ASME Code Section VIII pressure vessels. (Additional information is required for low temperature service, for type of construction, for extent of radiographic examination, and for special service vessels.)

### 3.2.1 Scope of API 620

The major aspects of the scope and limitations of API 620 are as follows:

- Intended for large, field-assembled tanks for containment of gases and liquids primarily associated with the petroleum industry.
- Internal pressures no greater than 0.1 MPa (15 psig).
- Metal temperatures between -37 and 93 °C (-35 and 200 °F); Appendices provide rules for lower temperature applications.
- Tank materials limited to carbon steels.

### 3.2.2 Design Rules

Some of the differences between API 620 and Section VIII, Division 1 of the ASME Code include:

- List of acceptable carbon steels categorized by minimum design metal temperature.
- Allowable design stress based on the lower of 30% of the specification minimum tensile strength or 60% of the minimum specification yield strength.
- Hydrostatic or combination hydrostatic-pneumatic test at 1.25 times the nominal pressure rating.
- Exceptions to postweld heat treatment requirements when such treatments are impractical due to physical size.

Overall, these differences are a slight relaxation of the Section VIII, Division 1 rules in consideration of the lower operating pressures.

Like Section VIII, API 620 has no explicit rules regarding inspection and evaluation in operation. However, API has another standard (API 510) for inservice inspection and rerating of tanks; this standard is discussed later.

### 3.2.3 Implementation of API 620

Upon approval of an application from the manufacturer, the API authorizes the official API Standard 620 symbol to be stamped on vessels made by authorized manufacturers. This symbol and the additional information required to be included in the stamping is indicated in figure 4.

In addition, the manufacturer is required to prepare a report summarizing all data on the tank and a conformance and certification form. The information to be included is shown in Appendix B.



API 620 Symbol

Information required in the marking:

1. Official API Standard 620 symbol
2. Manufacturer's name
3. Manufacturer's certificate of authorization number
4. Manufacturer's serial number
5. Nominal capacity
6. Design pressure for gas or vapor space at the top of the tank
7. Maximum permissible specific gravity of liquid contents to be stored
8. Maximum elevation to which tank may be filled for liquid of maximum specific gravity and design pressure at top of the tank
9. Maximum elevation to which tank may be filled with water for test or purging purposes
10. Year of completion
11. SR for stress relieved vessel
12. XR for radiographed vessel

Figure 4. Marking of low pressure storage tanks constructed in accordance with API Standard 620.

### 3.3 Remarks on Design Codes

It is useful to recall the philosophy underlying most design codes such as the ASME Code when evaluating the adequacy of a code for particular situations. The ASME Code and other codes are consensus documents that are intended to provide minimum requirements for adequate safety for the operational conditions considered and included in the design. Since they are minimum requirements, the owner is expected to specify, and the designer and the manufacturer should include additional requirements when it is anticipated that the equipment will experience severe and/or not fully known service conditions. This caveat is especially important in general purpose design codes such as Section VIII, Division 1 of the ASME Code.

A more difficult and subtle problem regarding the application of design codes occurs when service conditions change in time after some period of operation. Temperatures may increase or decrease more frequently, pressures and flow velocities may become more variable and cyclic, the composition of the process fluids may be slightly different, down-time care may become less carefully controlled, and greater demands may be put on old equipment. The owner of the pressure vessel may not be fully aware of the technical effects of these changes which were not addressed in the original design.

It is important to recall that the two design codes discussed above are design and construction codes. They do not contain rules and procedures for the inservice inspection, examination, and evaluation of the equipment. There is a growing awareness of the needs in this area and several organizations have been initiating or expanding their role in developing recommended practices, guidelines and evaluation criteria for this purpose. These activities are described later in this document in section 7.

## 4. DETERIORATION AND FAILURE MODES

A relatively large margin for reliability and safety is included in the design of pressure vessels and tanks. However, lack of understanding of all service conditions in design, poor quality control during manufacture, and changes in service conditions can erode this margin. A number of articles and books are available which discuss these factors. Among these, Thielsch's book [9] provides much general and specific information about deterioration mechanisms and failure behavior for pressure vessels and piping.

In general, conditions diminishing the safety margin can arise from inadequacies during design and manufacture, or from operational conditions, that is, preexisting before service or service-induced. These are described in greater detail in the following, but with the major emphasis on service-induced causes since these are the most pertinent for this document.

### 4.1 Preexisting Causes

#### 4.1.1 Design and Construction Related Deficiencies

Although design and construction deficiencies may not cause immediate reliability and safety problems, they can sometimes be the underlying reason



for later inservice problems. These preexisting situations include:

- Inadequate design considerations for the preservice, operational and down-time conditions.
- Poor design details such as lack of flexibility, severe geometrical stress risers and sharp changes in thickness.
- Improper materials either by wrong design selection or mistakes in identification; this includes both base materials and welds or other joint materials.
- Undetected defects in the base material and in the fabrication joints (welds).
- Incorrect heat treatments and cleaning procedures.

In most instances, a deficiency or error in one or more of these preexisting conditions does not lead to an immediate failure. Usually, only gross errors cause a failure during the hydrostatic test.

#### 4.1.2 Brittle Fracture

The possibility of a sudden and unexpected failure due to brittle fracture is an important consideration in safety and hazard assessment. This kind of failure can occur either due to preexisting conditions or to a combination of preexisting and service-induced conditions. Brittle fracture requires a combination of three factors:

- Existence of a crack or crack-like defect,
- A crack located in a high stress region, and
- A material with low notch toughness.

The initiating defect may exist because of its location in an uninspected region or a detection failure in the inspection. High stresses can be caused by geometrical stress raisers or by locked-in (residual) fabrication stresses, usually from welding. Welds that have not been thermally stress relieved are a prime source of residual stresses. Notch toughness is a measure of the material's sensitivity to brittle fracture. The value of notch toughness depends on temperature for carbon and low alloy steels with the material having a low value, or brittleness, at lower temperatures and transitioning to much higher toughness at higher temperatures. A typical carbon steel may have this "transition" in behavior over a 55 °C (100 °F) temperature range. For some grades of carbon steels, room temperature lies within the range of this transition. For other kinds and grades of steels, the transition may be at very low temperatures. This transition behavior does not involve any change in the physical characteristics of the material; it is a change in the response to mechanical factors.

These features explain why brittle fracture failures tend to occur when an adverse combination of the following conditions exists:

- Operation at low temperatures,
- Welds in the as-welded (not stress relieved) condition ,
- Incomplete or inadequate inspection, and
- Low notch toughness steel.

These characteristics of brittle fracture also explain why it can sometimes occur in service after a successful preservice hydrostatic test. Service conditions may include temperatures much lower than the hydrostatic test temperature, and crack-like defects may be produced or enlarged in operation. The latter effect is an important reason for including the possibility of brittle fracture in the evaluation of service-induced cracking damage. It may be noted that the new notch toughness rules adopted in Section VIII, Division 1 of the ASME Code [8] will provide additional margin against brittle failure for vessels manufactured in the future.

#### 4.2 Inservice Deterioration and Damage

Deterioration and damage to vessels and tanks as a result of operational service and attendant shutdown and down-time conditions produce three general classes of problems:

- Wastage and general loss of material,
- Localized attack and cracking, and
- Alteration of material properties.

There are a number of material, temperature, and environment related attack and deterioration mechanisms in each of these classes but the scope of this document eliminates some from consideration. For example, the material and temperature limits mean that material wastage by severe oxidation and embrittlement by high temperature exposure do not need to be considered. Similarly, certain kinds of localized corrosion peculiar to high alloy stainless steels are not pertinent. With these limitations, the following provides further information about specific mechanisms in each category listed above.

##### 4.2.1 General Material Loss

The two most common forms of general material loss that can occur in carbon and low alloy steel parts are corrosion and erosion. The ASME Code requires that the designer account for corrosion loss. However, in some cases, the corrosiveness of the fluid may not be fully communicated to the designer. Within the range of carbon and low alloy steel grades, chemical composition does not have a major influence in most cases of general corrosion and

therefore, material selection is not a primary factor. Severe cases of general corrosion require stainless steels or other corrosion resistant materials.

Erosion tends to occur in the piping system and valves more than in vessels and tanks because the wear is accentuated by high fluid velocity. Particulate matter content and two-phase flow also can increase the erosion rate. Turns, junctions, and area changes where the fluid flow has to change direction or velocity are regions most susceptible to erosion. Erosion by aqueous fluids often involves the loss of an adherent oxide scale which in turn appears to be related to the chromium content differences even within the low alloy grades. Thus, material selection of either the base material or weld materials can have a role in some instances of erosion.

The main safety consequence of deterioration by general material loss is the reduction in thickness and load carrying area which eventually can result in an overstress failure. Because of the relatively large safety margin included in pressure vessel design codes, considerable general material loss can be tolerated under nominal working pressure conditions, and field experience confirms this expectation.

#### 4.2.2 Localized Attack and Cracking

Unlike general material loss, localized attack and cracking can have a severe consequence much greater than in proportion to the amount of material degraded. This form of damage can be divided into several categories depending on the underlying cause:

- Stress related,
- Environment (chemical) related, or
- Combination stress and environment related.

The most common purely stress related localized damage is fatigue cracking. The cyclic stress responsible for fatigue can arise from purely mechanical sources such as pressure cycling or from stresses produced by thermal differentials in temperature cycling. Temperature cycling can be caused by system characteristics such as intermittent or periodic flow, frequent start-stop operation and problems with associated components such as a leaking valve. Changes in production schedules or rerouting of flow paths external to the vessel or tank may result in a greater intensity of cyclic stressing causing a condition that was previously benign to become critical.

Fatigue cracking resulting from cyclic stressing can involve either the enlargement of a preexisting discontinuity or the initiation and growth of crack where none existed before. The location in the first case will be determined completely by the location of the existing discontinuity and the rate of growth will depend on the intensity of stresses at the location. In the second case, the cracking often initiates and grows in regions of high stress such as at geometrical transitions and at or near welds.

Occasionally, a system related condition like "water hammer" can be a source of cyclic or varying pressure and stresses. Obviously, improper or poor control of flow, pressures and temperatures are a source of abnormal and varying stresses.

The second category of localized attack listed above, namely, that due to chemical attack by the environment alone without the necessity for stress, occurs in one of several ways:

- Pitting corrosion resulting in numerous surface cavities,
- Selective galvanic corrosion in the region between two electrochemically different metals,
- Selective corrosion attack along a metallurgically altered region, commonly the weld heat affected zone (HAZ), or
- Corrosion attack in crevices resulting from the concentration of the aggressive chemical specie(s).

It is impossible to list the many combinations of chemical species, concentrations, metallurgical conditions, temperatures, and geometries where problems due to localized chemical attack have been observed. Specialized reference articles and handbooks are available for detailed discussion of the problem and precautions. However, some commentaries on the safety consequences will be helpful.

Pitting corrosion attack generally does not pose a safety hazard for pressure vessels because the rate of attack is relatively small compared to the usual thickness of the vessel wall. Severe through wall pitting attack is a leakage problem in thinner wall parts such as heat exchanger tubing.

The other three types of selective attack listed above can lead to significant safety problems because, in the extreme, they can produce a crack-like discontinuity. Additionally, the localized susceptible regions can be located in areas difficult to inspect. The crevice under the weld backing material is an example.

The third category of localized attack is stress corrosion cracking (SCC); it results from the combined action of stress and environment. The occurrence of SCC requires a combination of three conditions:

- Susceptible material or material condition,
- Chemically aggressive environment, and
- Sufficiently high stress.

SCC will not occur if the magnitude of any one of the three conditions is not sufficient.

There are several distinctive characteristics about SCC which can be summarized by the following:

- Very little or no general corrosion in the surface region around the cracking, and virtually no corrosion of the crack surfaces.
- Cracking on a plane transverse to the principal stress direction in the region; this may not always coincide with the direction of primary loading due to local perturbations.
- In cross section, the cracking may proceed as a single continuous crack or with a branching pattern.
- Metallurgically, the cracking can be through the grains (transgranular) or along the grain boundaries (intergranular).

Sketches in figure 5 schematically illustrate some of the major features of SCC.

Since three factors are involved, generalizations about environments that can cause SCC are difficult even when restricted to a specific class of material. However, experiments and service experience have identified environments that can or have caused SCC in carbon and low alloy steels, and these have been tabulated and described in many references, for example, Logan [10]. The listing below from Logan and other sources gives the major damaging environments for carbon and low alloy steels:

- Hot or boiling caustic (sodium hydroxide) solutions, the cause of "caustic embrittlement",
- Hot or cold nitrate solutions,
- Wet hydrogen sulfide, the cause of "sulfide cracking",
- Anhydrous ammonia, possibly aggravated by air and carbon dioxide contamination,
- Amine solutions, and
- Hot, oxygenated water.

Experience and statistics for vessels in service in several of these environments are discussed in greater detail in section 6.

The metallurgical condition of the material is an important determinant of the severity of the SCC problem. In general, sensitivity to SCC increases with hardness and strength. Therefore, high strength bolts and the HAZ of welds without a postweld heat treatment (not stress relieved) are examples of susceptible materials and conditions.

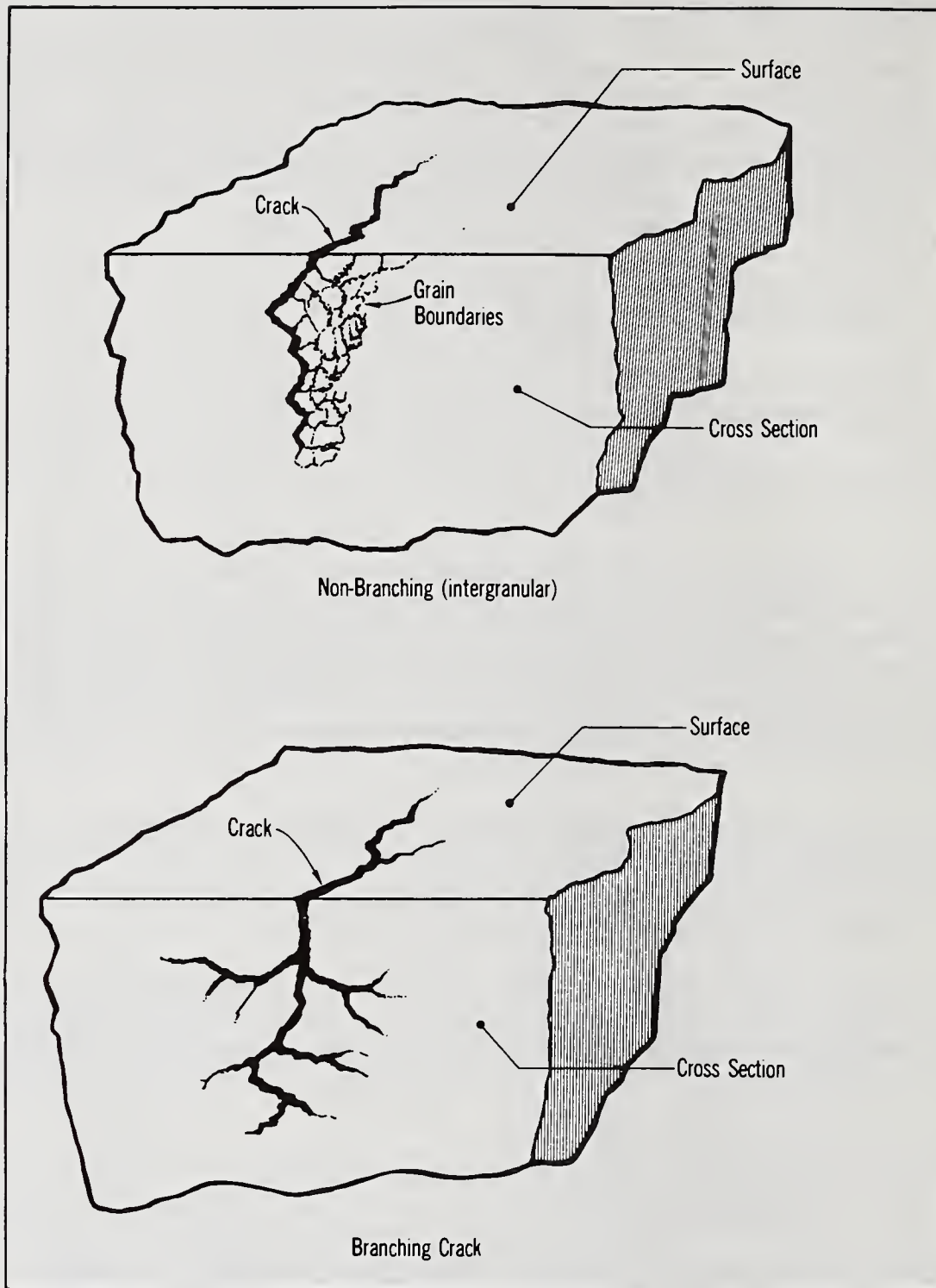

Figure 5. Illustration of non-branching and branching stress corrosion cracks. (Both can be either intergranular or transgranular.)

Stress is the third required ingredient for SCC and high stresses, both applied and residual, increase the severity of the problem. There has been much effort to determine a lower limiting threshold stress for SCC, or more recently, the limiting fracture mechanics quantity "threshold stress intensity factor,  $K_{I_{SCC}}$ " as illustrated in figure 6, and these values are very useful for design.

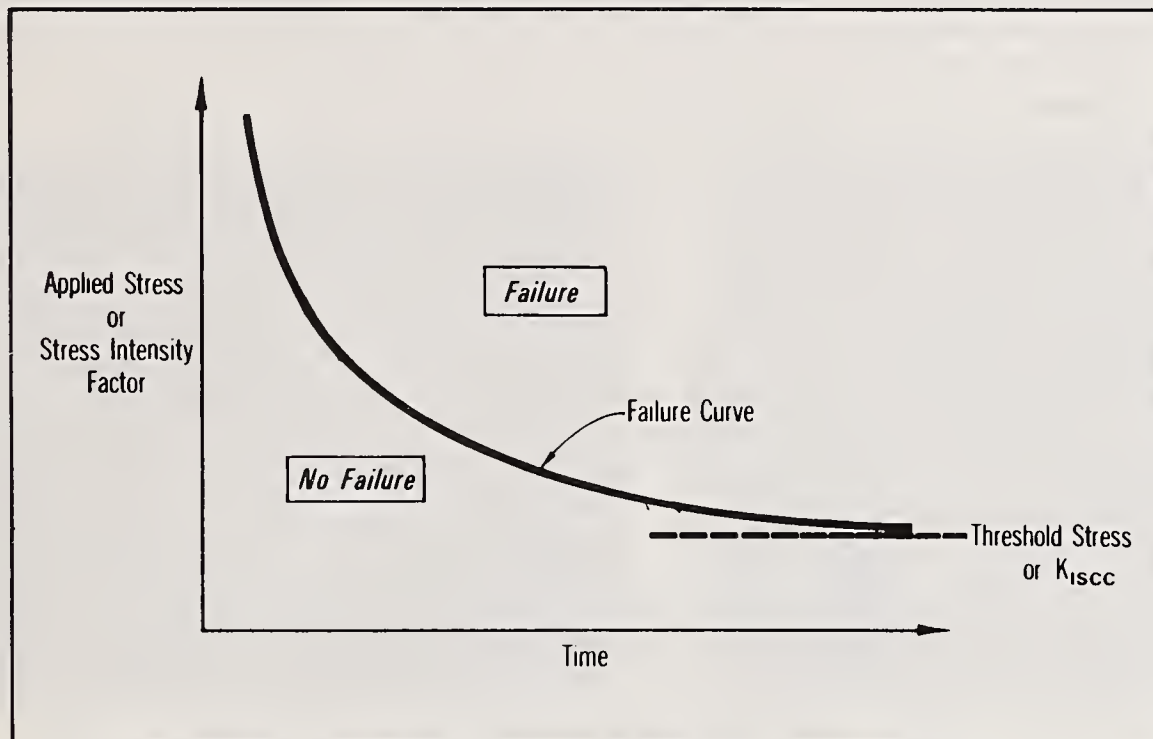

Figure 6. Concept of threshold stress or stress intensity factor ( $K_{I_{SCC}}$ ) in stress corrosion cracking.

However, very little of this kind of data exists for carbon and low alloy steels in the environments of interest; in addition, using these as a design basis means that careful attention has to be paid to eliminating or minimizing stress concentration details and sources of residual stresses such as severe machining and welds in the as-welded condition.

In addition to SCC, some environments can accelerate fatigue crack growth. For carbon and low alloy steels, hot water containing small amounts of dissolved oxygen appears to be such a detrimental environment. This problem of the interaction between the environment and fatigue crack growth is a relatively recent area of study and a listing of detrimental environments is incomplete.

Stress corrosion cracking and environmentally assisted fatigue crack growth have major and severe safety and hazard consequences for two reasons. The resulting crack-like defects have a detrimental effect on structural integrity that far outweighs the amount of material affected. In addition, SCC

and fatigue cracking often occur in high stress regions. For these reasons, SCC and fatigue cracking are damage mechanisms of major concern for pressure vessel safety assessment.

#### 4.2.3 Material Property Degradation

A number of operating conditions can change the properties of materials. Some of the well known among these include high temperature thermal exposure and nuclear radiation. However, within the material and temperature scope of this document, only one service environment is of major concern in this regard. This is the degradation caused by ingress of hydrogen into carbon and low alloy steels from a hydrogen producing reaction at the metal surface. Aqueous solutions containing hydrogen sulfide is a prime example of an environment known to cause the generation and uptake of the hydrogen into steels.

A loss of ductility in ordinary tensile tests caused by hydrogen dissolved in steels has been known for a long time. Recent tests [3] indicate that fracture mechanics quantities, such as fracture toughness and tearing resistance, can also be decreased by the presence of dissolved hydrogen. Additional studies are needed to develop a full understanding of dissolved hydrogen effects on fracture mechanics properties and the results would be an important consideration in evaluating the safety and hazards of vessels operating in hydrogen producing environments.

The effects of dissolved hydrogen on ductility and toughness are manifested without the formation of any internal physical discontinuities. However, if the amount of hydrogen ingress becomes excessive, a damage condition known as "blistering" can occur. It is characterized by irregularly spaced, small-to-fairly large swellings on the surface of the steel. Cross-sectioning through these swellings shows that voids have formed on a plane parallel to steel surface. Figure 7 shows the surface appearance of blistering and cross sections of blisters.

A small amount of blister formation would generally not have a major detrimental effect on structural integrity and safety margin. This is partly because the planes of responsible voids are nearly parallel to the vessel surface and therefore not subjected to pressure stresses. However, blister formation is an indicator that hydrogen ingress into the material has occurred, and that other forms of localized cracking and degradation of properties may be present.

### 5. INSPECTION METHODS AND IMPLEMENTATION

A working understanding of nondestructive examination (NDE) methods and their capabilities and limitations in the inspection of vessels and tanks is an important element in the safety assessment of these structures. The total NDE scope involves a number of organizations whose activities cover the formulation of NDE requirements and acceptance standards, the development and validation of NDE techniques, and the qualification and certification of NDE personnel.

The first part of this section provides a brief description of organizations involved in the NDE of pressure vessels and the relationship



among them. This is followed by a summary of the major NDE methods and some remarks about the capabilities and limitations of each method.

## 5.1 Role of Organizations Involved

### 5.1.1 ASME Code

Section VIII of the Code contains examination requirements, acceptance standards, and personnel qualification requirements specific to the materials



Surface Appearance

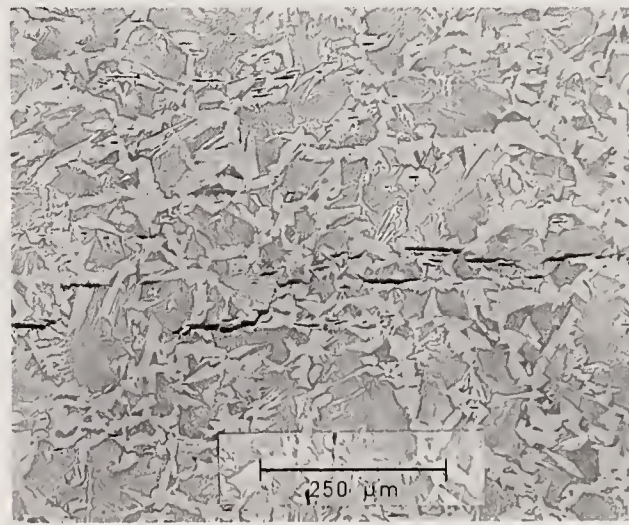

Magnified Cross Section Appearance

Figure 7. Appearance of hydrogen induced blisters in a carbon steel.

and fabrication processes permitted in this Section of the Code. In addition, Section VIII refers to Section V, "Nondestructive Examination" [11] of the Code for requirements and guidelines relating to the general aspects of NDE techniques and personnel qualification.

Specifically, Section VIII requires that personnel performing radiographic examination of welds shall be qualified and certified to a written practice. The guideline for this purpose is the ASNT (American Society for Nondestructive Testing) recommended practice which is described later. For other NDE methods, Section VIII requires the manufacturer to certify personnel competency but specific use of the ASNT recommended practice as the guideline is not required. Overall, the ASME Code uses the format that if the design Section has no specific personnel qualification requirements, then the requirements of Section V of the Code applies which in turn is often an ASNT recommended practice.

### 5.1.2 API Standards

API Standard 620, for the design and fabrication of low pressure storage tanks, requires that the NDE methods when specified be in accordance with Section V of the ASME Code. The acceptance standards for the specified NDE methods are essentially identical to ASME Section VIII, Division 1 requirements. API has no specific requirements regarding the qualifications of the personnel performing the NDE tests and evaluations.

API has another standard, API 510, for the inservice inspection of vessels and tanks used in the petroleum and chemical industries [12]. Usually, this inservice inspection is done under the direction of a third party inspector whose qualifications are those required by the inspector's employer.

API 510 also permits inservice inspection to be done under the direction of an inspector employed by an owner-user (the Owner-User Inspector). In this case, the inspector is required to have one of several alternative education and experience qualifications which in brief are:

- Engineering degree plus 1 year of relevant experience, or
- A 2-year engineering or technology certificate plus 2 years of relevant experience, or
- High school education or equivalent plus 3 years of relevant experience.

API 510 has no specified certification requirements for the personnel performing the NDE.

### 5.1.3 National Board

To aid in their efforts to maintain uniformity in the construction, inspection, and repair of pressure vessels, the National Board of Boiler and Pressure Vessel Inspectors issues a Manual entitled "National Board Inspection Code" [13]. This Manual covers both initial and inservice inspections.

For inservice inspection, the National Board Inspection Code (NBIC) is intended for application to installations other than those covered by API 510. NBIC inservice inspections can be performed by Authorized Inspectors or by Owner-User Inspectors. Authorized Inspectors are third-party individuals who hold National Board Commissions and who are authorized by the applicable jurisdictions. Owner-User Inspectors also must hold a National Board Commission and be authorized by the jurisdiction but are employed by the owner-user of the pressure vessels. The education and experience requirements for a NBIC Owner-User Inspector are essentially identical to those described above for an API 510 Owner-User Inspector.

Like API 510, the National Board Code does not have specific certification requirements for the personnel performing the examinations.

#### 5.1.4 ASNT Recommended Practice

The ASNT in their Recommended Practice No. SNT-TC-1A [14] provides initial qualifications, training guidelines, and examination requirements for three qualification levels of personnel performing NDE. The three levels are I, II, and III in order of increasing qualification. Table I summarizes the main features of SNT-TC-1A to provide more information about the three levels of certification.

This recommended practice is used by many organizations as a guideline for their internal competency testing and qualifying of NDE personnel, and by design codes and inspection agencies as a requirement for personnel certification.

#### 5.1.5 ASTM Specifications

ASTM (American Society for Testing and Materials) issues many specifications and test methods for NDE. The ASME Code has adopted and included ASTM specifications and methods which are relevant to pressure vessel applications in its Section V on NDE. In these cases, the ASME Section V methods and procedures are identical to the corresponding ASTM specification.

#### 5.1.6 NACE Recommended Practices

NACE (National Association of Corrosion Engineers) has issued or is preparing recommended practices for the inspection of vessels in some applications that have been experiencing problems. In some cases, the recommended practice includes a requirement that the NDE must be done by personnel holding a specified ASNT Level certification. Details are given later in connection with pressure vessel cracking experience.

TABLE I  
 SUMMARY OF ASNT RECOMMENDED PRACTICE SNT-TC-1A  
 "QUALIFICATION AND CERTIFICATION PROGRAM FOR NDE PERSONNEL"

<u>NDT Level</u>	<u>Definition of Qualification</u>	<u>Education and Experience Requirements and Training Recommendation</u>	<u>Examination for Certification</u>
I	Qualified to properly perform specific calibrations, tests and evaluations ... according to written instructions ... shall receive instruction/supervision from a Level II or III person.	Four to 88 hours of instruction depending on educational background and NDE method plus one to six months experience before initial qualification.	General and specific written exam. plus a practical proficiency exam. for each NDE method.
II	Qualified to set up and calibrate equipment and to interpret and evaluate results per applicable codes, standards and specifications ... familiar with scope and limitations of methods ... prepare written instructions and reports.	Four to 85 hours of instruction plus two to 18 months experience.	Same as Level I
III	Capable of establishing techniques and procedures; interpreting codes, specifications, and procedures; designating test methods and procedure, and assist in establishing acceptance criteria.	Engineering/science degree plus one year experience, or Two years engin./science studies plus two years experience, or Four years Level II experience	Common basic exam. plus Method and specific exam. for each NDE method.

## 5.2 Examination Methods

The application of NDE methods involves many considerations about materials and fabrication, structural geometry, and accessibility for examination. A detailed discussion of each of these methods and applications is beyond the scope of this document but references such as those by McMasters [15], McGonnagle [16], and Chapter IV of the API Guide [17] can be consulted for additional information.

Of the various conventional and advanced NDE methods, five are widely used for the examination of pressure vessels and tanks and the discussion in this section will be limited to these five. The names and acronyms of these five are:

Visual Examination .....	VT
Liquid Penetrant Test .....	PT
Magnetic Particle Test .....	MT
Gamma and X-ray Radiography ..	RT
Ultrasonic Test .....	UT

There is a significant difference in the capabilities and therefore applicability between the first three methods as a group and the last two. VT, PT and MT can detect only those discontinuities and defects that are open to the surface or are very near the surface. In contrast, RT and UT can detect conditions that are located within the part. For these reasons, the first three are often referred to as "surface" examination methods and the last two as "volumetric" methods.

Table II summarizes the main features of these five methods; additional commentary on each is presented in the following.

### 5.2.1 Visual Examination (VT)

A visual examination is easy to conduct and can cover a large area in a short time. It is very useful for assessing the general condition of the equipment and for detecting some specific problems such as severe instances of corrosion, erosion, and hydrogen blistering. The obvious requirements for a meaningful visual examination are a clean surface and good illumination.

### 5.2.2 Liquid Penetrant Test (PT)

This method depends on allowing a specially formulated liquid (penetrant) to seep into an open discontinuity and then detecting the entrapped liquid by a developing agent. When the penetrant is removed from the surface, some of it remains entrapped in the discontinuities. Application of a developer draws out the entrapped penetrant and magnifies the discontinuity. Chemicals which

TABLE II  
SUMMARY OF NDE METHODS

<u>Method</u>	<u>Physical Principle</u>	<u>Application Technique</u>	<u>Ideal Sensitivity</u>	<u>Precautions and Limitations</u>	<u>Flaw Sizing Capability</u>
Visual (VT)	Vision			Clean surface, good illumination	
Penetrant (PT)	Selective absorption of a liquid penetrant into a discontinuity by capillary action	Apply and remove penetrant Apply developer which extracts penetrant from the discontinuity	0.05 mm dia. x 0.05 mm deep hole	Clean surface, no "smeared" metal; "tight" cracks may be missed	Surface length only
Magnetic Particle (MT)	Local distortion of magnetic flux lines by a discontinuity	Induce magnetic field Apply magnetic powder which concentrates at discontinuities	0.8 mm long x 0.1 mm deep	Ferromagnetic metals only Clean surface Avoid probe arcing	Surface length only
Radiography (RT)	Differential absorption of x-rays	Source of x-rays Record differences in transmitted intensities on film	0.3-0.5% of the thickness	Sharp radiographs require long exposures Difficulty detecting tight cracks Obscuring by geometrical features	Difficult for dimension parallel to beam
Ultrasonic (UT)	Attenuation or reflection of elastic waves by discontinuities	Transducers to inject waves into a part Detect transmitted or reflected signal and display on CRT	Frequency dependent, about 6 mm @ 1 MHz, 1.3 mm @ 5 MHz	Signal attenuation with distance Beam spread Return signal amplitude depends on characteristics and part geometry	Requires careful calibration and compensation

fluoresce under black (ultraviolet) light can be added to the penetrant to aid the detectability and visibility of the developed indications. The essential feature of PT is that the discontinuity must be "open," which means a clean, undisturbed surface.

The PT method is independent of the type and composition of the metal alloy so it can be used for the examination of austenitic stainless steels and nonferrous alloys where the magnetic particle test is not applicable.

### 5.2.3 Magnetic Particle Test (MT)

This method depends on the fact that discontinuities in or near the surface perturb magnetic flux lines induced into a ferromagnetic material. The magnetic field can be induced into the part by various means. For a component such as a pressure vessel where access is generally limited to one surface at a time, the "prod" technique is widely used. The essentials of this technique and its application for examining a weld seam are illustrated in figure 8. The magnetic field is produced in the region around and between the prods (contact probes) by an electric current (either AC or DC) flowing between the prods. The ferromagnetic material requirement basically limits the applicability of MT to carbon and low alloy steels.

The perturbations of the magnetic lines are revealed by applying fine particles of a ferromagnetic material to the surface. The particles can be either a dry powder or a wet suspension in a liquid. The particles can also be treated to fluoresce under black light. These options lead to variations such as the "wet fluorescent magnetic particle test" (WFMT).

MT has some capability for detecting subsurface defects. However, there is no easy way to determine the limiting depth of sensitivity since it is highly dependent on magnetizing current, material, and geometry and size of the defect. A very crude approximation would be a depth no more than 1.5 to 3 mm (1/16 to 1/8 in).

The sketches in figure 9 illustrate the appearance of MT indications associated with cracks and discontinuities that might occur in and near welds.

A very important precaution in performing MT is that corners and surface irregularities also perturb the magnetic field. Therefore, examining for defects in corners and near or in welds must be performed with extra care. Another precaution is that MT is most sensitive to discontinuities which are oriented transverse to the magnetic flux lines and this characteristic needs to be taken into account in determining the procedure for inducing the magnetic field.

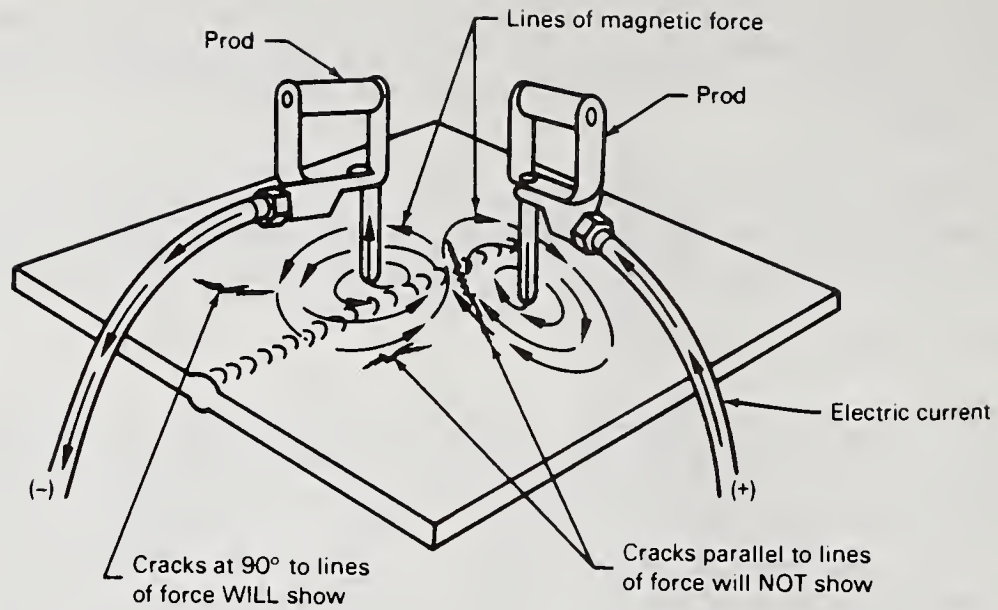

Prod technique for magnetic particle inspection of welds  
 (From: Welding Handbook, Vol. 5, 7th ed., Am. Weld. Soc.)



Examining a welded tank by magnetic particle method  
 (From: Principles of Magnetic Particle Testing,  
 MAGNAFLUX, 1985)

Figure 8. Principles and application of magnetic particle testing.



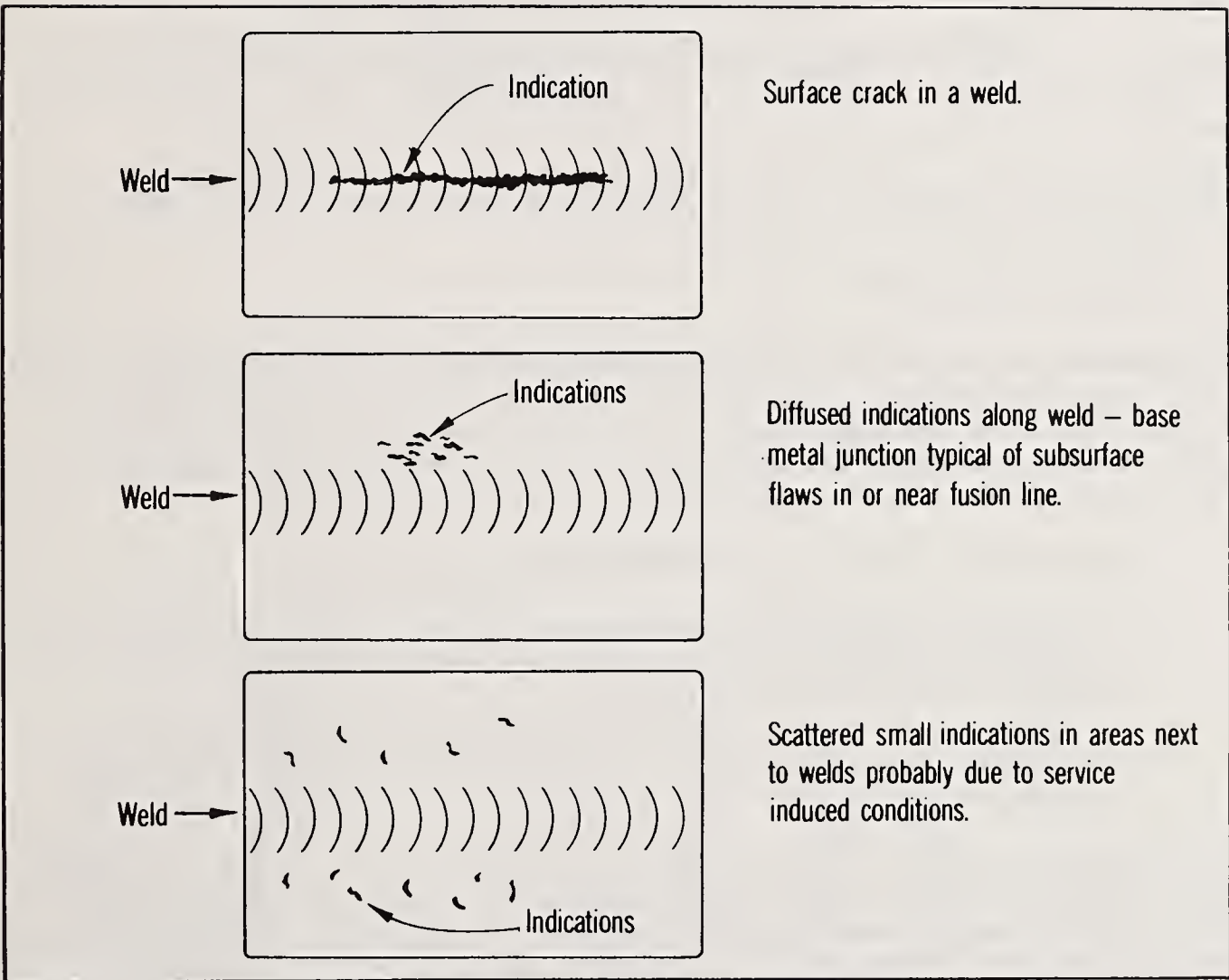

Figure 9. Illustrations of magnetic particle test indications due to various causes.

#### 5.2.4 Radiography (RT)

The basic principle of radiographic examination of metallic objects is the same as in any other form of radiography such as medical radiography. Holes, voids, and discontinuities decrease the attenuation of the x-ray and produce greater exposure on the film (darker areas on the negative film).

Because RT depends on density differences, cracks with tightly closed surfaces are much more difficult to detect than open voids. Also, defects located in an area of a abrupt dimensional change are difficult to detect due to the superimposed density difference. RT is effective in showing defect dimensions on a plane normal to the beam direction but determination of the depth dimension and location requires specialized techniques.

Sets of reference radiographs for various materials and product forms showing typical kinds of defects are available from ASTM. They include E 186, E 280 and E 446 for steel castings and E 390 for steel fusion welds.

Since ionizing radiation is involved, field application of RT requires careful implementation to prevent health hazards.

#### 5.2.5 Ultrasonic Testing (UT)

The fundamental principles of ultrasonic testing of metallic materials are similar to radar and related methods of using electromagnetic and acoustic waves for detection of foreign objects. The distinctive aspect of UT for the inspection of metallic parts is that the waves are mechanical, so the test equipment requires three basic components:

- Electronic system for generating electrical signal.
- Transducer system to convert the electrical signal into mechanical vibrations and vice versa and to inject the vibrations into and extract them from the material.
- Electronic system for amplifying, processing and displaying the return signal.

For volumetric examination, two kinds of waves can be induced in metallic materials; longitudinal waves and shear waves as illustrated in figure 10. Ultrasonic testing can be done in several different modes but the pulse-echo technique illustrated in figure 11 is probably the most widely used for examination of structural equipment because of its convenience and flexibility.

In this mode, very short signal pulses are induced into the material and waves reflected back from discontinuities are detected during the "receive" mode. The transmitting and detection can be done with one transducer or with two separate transducers (the tandem technique). Figure 12 shows the essentials of UT examination of a weld and adjacent region by the angle beam, single transducer technique.

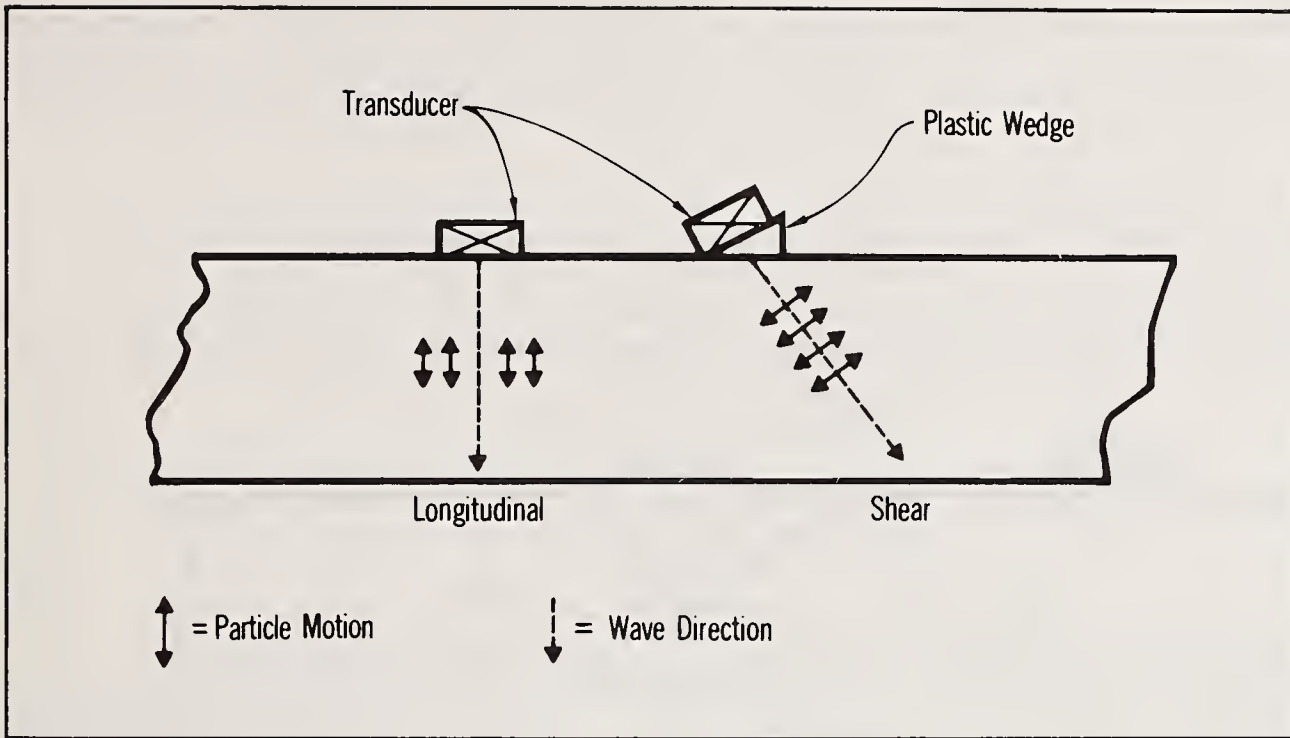

Figure 10. Longitudinal and shear waves utilized in ultrasonic examination.

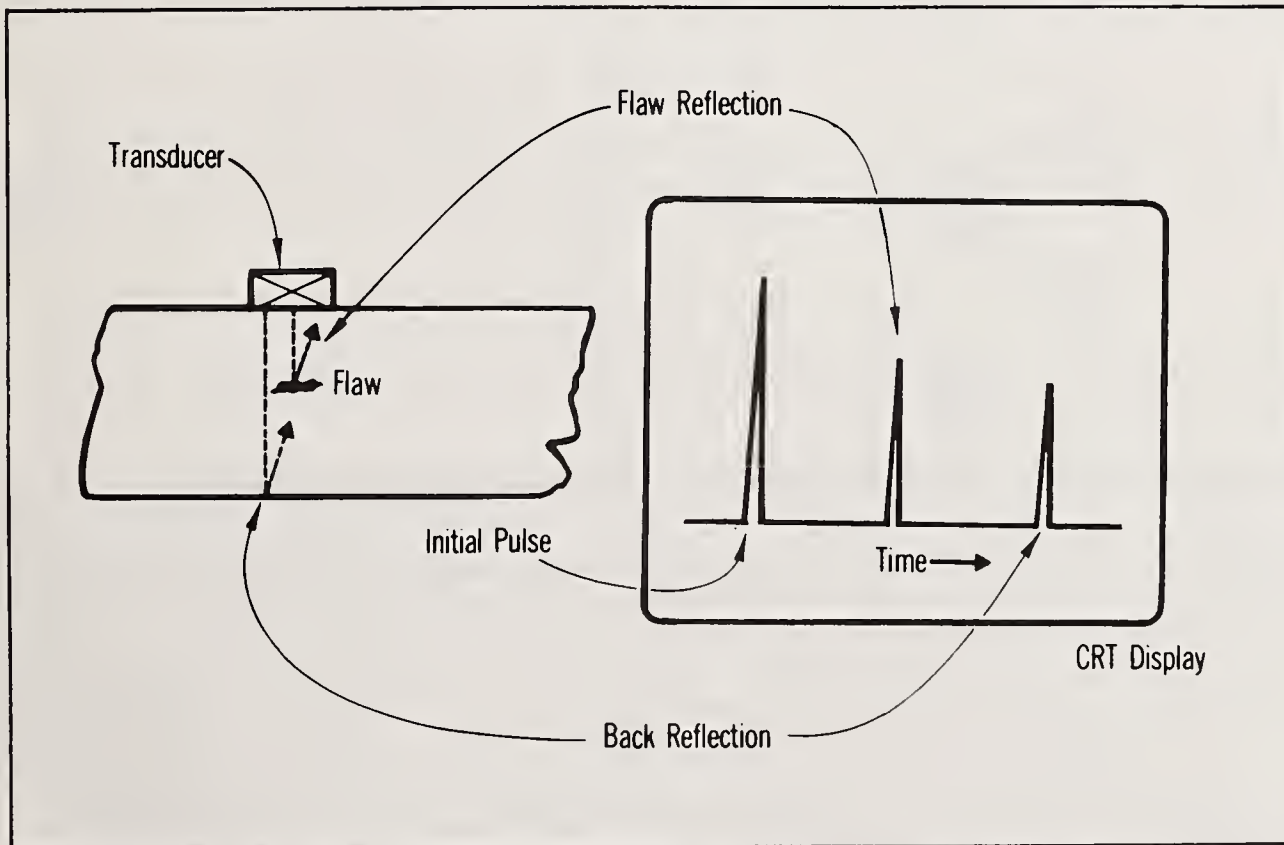

Figure 11. Principles of pulse-echo ultrasonic technique.

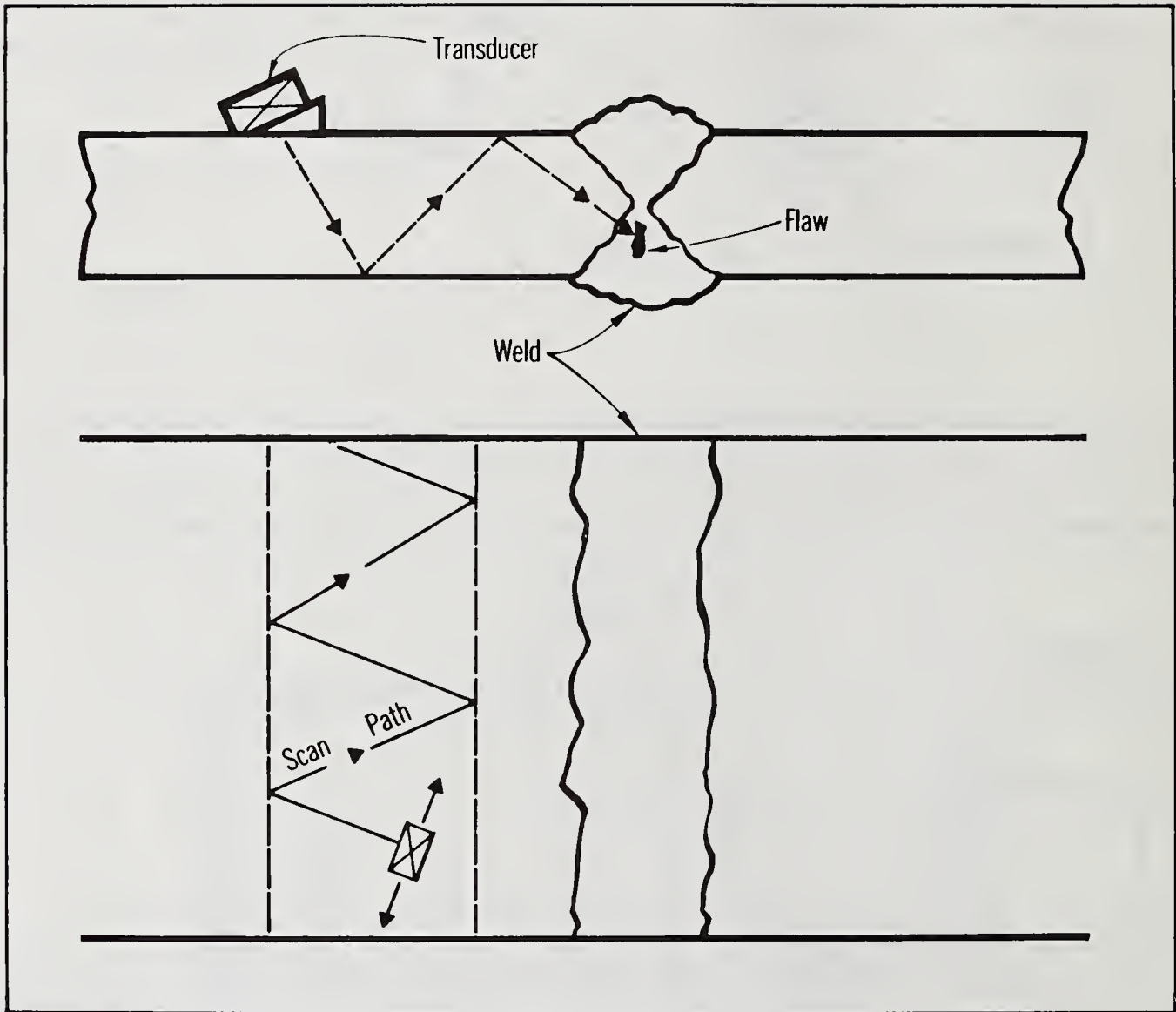

Figure 12. Basic features of angle beam ultrasonic examination of a butt weld.

The most common way of displaying the detected signal is a time based display of the amplitude of the signals on a CRT screen as shown schematically in figure 11. Since the wave velocity is constant, the position of the reflected signal from a discontinuity on the time scale is a good measure of its location within the part.

Although the amplitude of the reflected signal in UT provides some measure of the size of the discontinuity, the effect of many other factors (orientation, geometry, type of discontinuity, distance) are involved. To account for some of these reasons, the amplitude is often reported in relative values. Two normalizing indices commonly used for this purpose are:

- Amplitude of the back reflection, or
- Amplitude of the reflection from a flat bottomed hole (FBH) at the same location as the detected indication.

Amplitudes are then reported as % Back Reflection or %FBH.

Unlike radiography, UT in its basic form does not produce a permanent record of the examination. However, more recent versions of UT equipment include automated operation and electronic recording of the signals.

Ultrasonic techniques can also be used for the detection and measurement of general material loss such as by corrosion and erosion. Since wave velocity is constant for a specific material, the transit time between the initial pulse and the back reflection is a measure of the travel distance and the thickness.

### 5.3 Detection Probabilities and Flaw Sizing

The implementation of NDE results for structural integrity and safety assessment involves a detailed consideration of two separate but interrelated factors:

- Detecting the discontinuity, and
- Identifying the nature of the discontinuity and determining its size.

Table II has notations indicating the ideal sensitivity of each NDE technique. This information indicates the capabilities of the methods under ideal, laboratory environment conditions with experienced test personnel. Many conditions, some of which were noted above for each method and which will be inherent to actual examinations, will make the real detection capability less than the ideal sensitivity. Also, since human factors are involved, quantification of capabilities can only be based on experimental data from replicate and round-robin tests expressed in probabilistic terms.

Much of the available information on detection and sizing capabilities has been developed for aircraft and nuclear power applications and is summarized in Bush's comprehensive discussion of NDE reliability [18]. This kind of information is very specific to the nature of the flaw, the material, and the

details of the test technique, and direct transference to other situations is not always warranted. However, data for one case of a round-robin examination of surface fatigue cracks in a very high strength steel serves to illustrate the nature of the problem. In this case, MT and UT were able to detect cracks of surface flaw lengths in the 2 to 3 mm (0.08 to 0.1 in) range with 90% probability of detection at 95% confidence level while the probability was zero by RT. Unfortunately, there has been no systematic studies of this kind for cracks and flaws that might be found in pressure vessels for general applications.

Once detected, the size of the discontinuity and if possible its exact type needs to be determined. These determinations are much easier for surface discontinuities compared to embedded ones. Later discussion in section 6 will indicate that surface cracking seems to be the predominant problem in vessels of interest in this document. In this case, the flaw sizing problem becomes one of determining the depth dimension.

The overall reliability of NDE is obviously an important factor in a safety and hazard assessment. Failing to detect or undersizing existing discontinuities reduces the safety margin while oversizing errors can result in unnecessary and expensive outages. High reliability results from a combination of factors:

- Validated procedures, equipment and test personnel,
- Utilization of diverse methods and techniques, and
- Application of redundancy by repetitive and independent tests.

Finally, it is useful to note that safety assessment depends on evaluating the "largest flaw that may be missed, not the smallest one that can be found."

## 6. RECENT CRACKING EXPERIENCE IN PRESSURE VESSELS

The Introduction noted that surveys and service experience are indicating damage problems occurring in pressure vessels in several application areas. These problems are discussed in greater detail in this section. The applications covered are vessels and tanks in deaerator, amine, wet hydrogen sulfide, ammonia storage and pulp digesting service.

### 6.1 Deaerator Service

Deaeration refers to the removal of non-condensable gases, primarily oxygen, from the water used in a steam generation system. Figure 13 schematically illustrates the function of the deaerator vessel in the flow stream. Deaerators are widely used in many industrial applications including power generation, pulp and paper, chemical, and petroleum refining and in many public facilities such as hospitals and schools where steam generation is required. In actual practice, the deaerator vessel can be separate from the storage vessel, as illustrated in figure 13, or combined with a storage vessel into one unit.

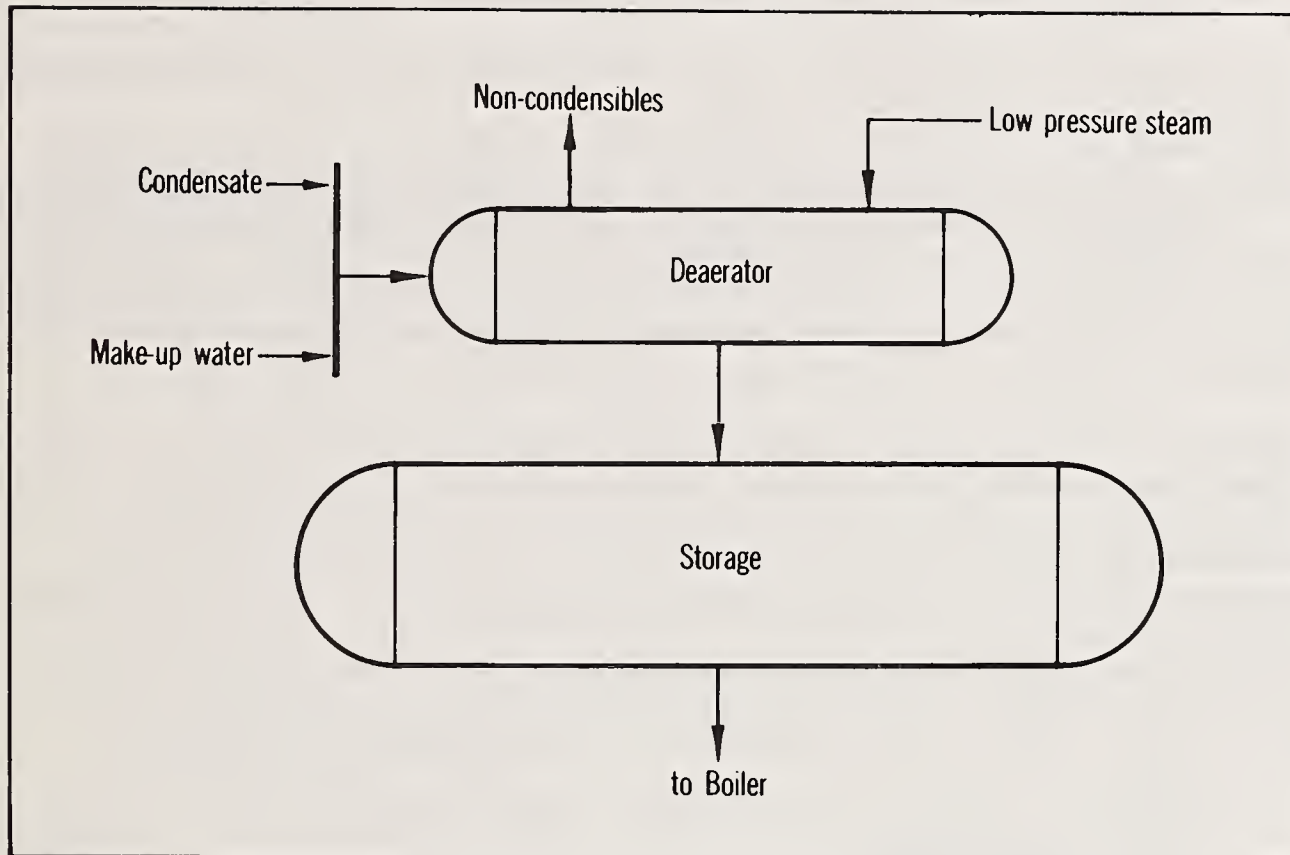

Figure 13. Simplified flow diagram for feedwater deaerator/storage system.

Typical operational conditions for deaerator vessels range up to about 2.1 MPa (300 psi) and up to about 150 °C (300 °F). Nearly all of the vessels are designed to ASME Code, Section VIII, Division 1 rules resulting in vessel wall thicknesses up to but generally less than 25 mm (1 in). The vessel material is almost universally one of the carbon steel grades.

Following some serious deaerator vessel failures in 1982 and 1983, a NACE (National Association of Corrosion Engineers) Task Group undertook a survey of industry experience in this application. A summary of the survey results have been reported by Robinson [19] and show that cracking had been detected in over 30% of the 84 vessels in the survey. Case histories of some cracking incidents have been described by Franco and Buchheim [20] and survey results in specific industries have been provided by Winters [21] and by Vormelker [22]. The last two references report cracking incidences of 42% and 50%. An update of the NACE Task Group effort is given in a recent paper by Kelly et al. [23].

Analysis of the survey data and other investigations has determined the following features about the cracking:

- Water hammer is the only design or operational factor that correlates with cracking.
- Cracking is generally limited to weld regions of vessels that had not been postweld heat treated.
- Corrosion fatigue appears to be the predominant mechanism of crack formation and growth as indicated by the studies of Herro [24], Copeland, et al. [25] and others.

The weld and welding practice parameters that are involved in the sensitivity of and localization to weld regions have been discussed by Gooch [26].

The failures and the survey results have prompted several groups to prepare inspection, operation and repair recommendations. The groups are TAPPI (Technical Association of Pulp and Paper Industry), the National Board of Boiler and Pressure Vessel Inspectors, and NACE. The main features of the TAPPI recommendations have been published by Beckwith et al. [27] and a summary of the NACE recommendations has also been published [23,28]. The National Board guidelines are scheduled to be in an Appendix to the next edition of the Inspection Code and NACE's proposed recommended practice is planned to be published in 1988 or 1989. For inspection, all recommendations suggest:

- Special attention to the internal surface of all welds and heat-affected zones (HAZ).
- Use of the wet fluorescent magnetic particle (WFMT) method for inspection.

The TAPPI and the NACE recommendations also contain additional items:

- Inspection by personnel certified to ASNT's SNT-TC-1A minimum Level I and interpretation of the results by minimum Level II.
- Reinspection within 1 year for repaired vessels, 1-2 years for vessels with discontinuities but unrepaired, and 3-5 years for vessels found free of discontinuities.

In addition, both TAPPI and NACE give general and specific recommendations for operating practice to minimize damage and for repair procedures.

Whenever crack indications are found in the inspections, the structural integrity and safety of the vessel for continued operation has to be evaluated. Copeland et al. [25] has reported the results of a fracture mechanics analysis for one group of deaerator vessels. They concluded that cracks transversely oriented to the weld direction may be acceptable for continued service without repair provided the pressure stresses were fairly low (less than 52 MPa, 7.5 ksi) which was the case for many vessels in this group. Repairs were recommended if the stresses were higher or if the cracks were parallel to the



weld direction for all stresses. These conclusions were for a particular group of vessels with specific material, material properties, and design parameters and would not necessarily apply to other cases. However, it does demonstrate the use of fracture mechanics analysis to evaluate whether removal of all crack indications are necessary or not.

## 6.2 Amine Service

The amine process is used to remove hydrogen sulfide ( $H_2S$ ) from petroleum gases such as propane and butane. It is also used for carbon dioxide ( $CO_2$ ) removal in some processes. Amine is a generic term and includes monoethanolamine (MEA), diethanolamine (DEA) and others in the amine group. Figure 14 shows a simplified flow diagram of an amine treatment plant. These units are used in petroleum refinery, gas treatment and chemical plants.

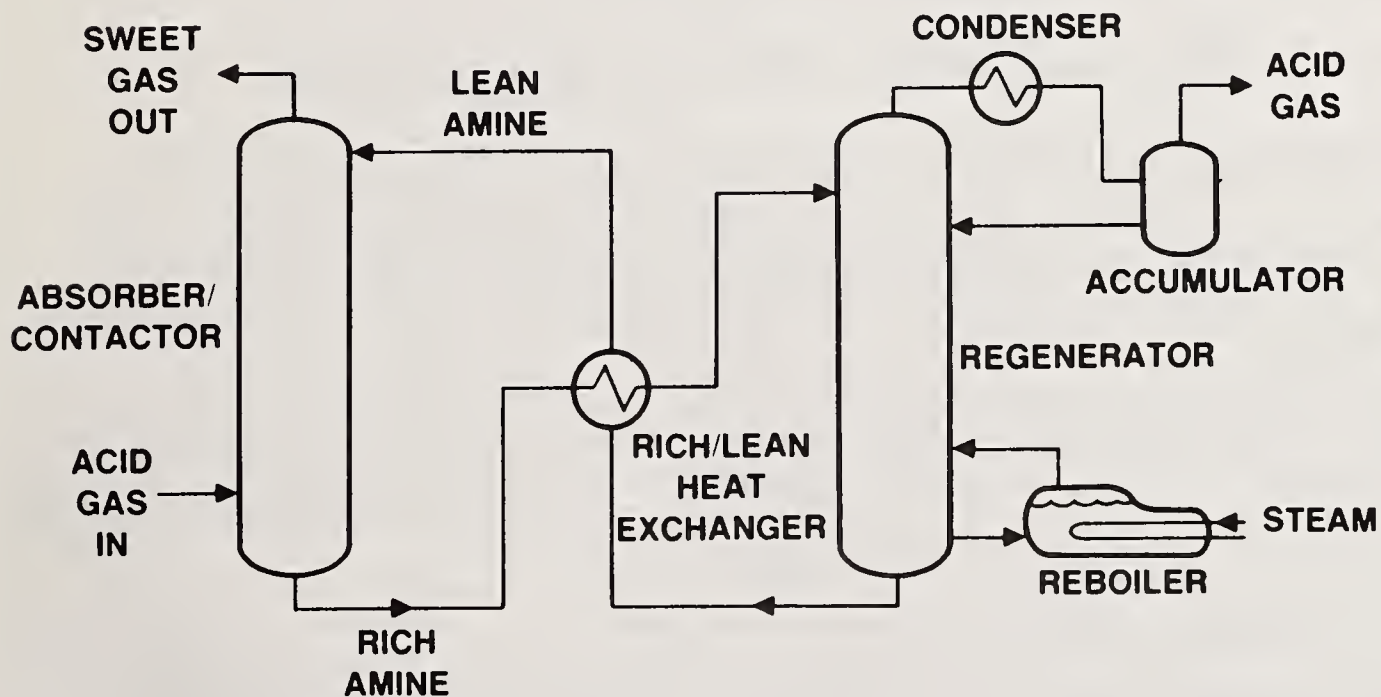

Figure 14. Simplified process flow diagram of amine plant [29].

The operating temperatures of the amine process are generally in the 38 to 93 °C (100 to 200 °F) range and therefore the plant equipment is usually constructed from one of the carbon steel grades. The wall thickness of the pressure vessels in amine plants is typically about 25 mm (1 in).

Although the possibility of cracking of carbon steels in an amine environment has been known for some years, real concern about safety implications was highlighted by the 1984 failure of the amine process pressure vessel mentioned earlier. While the complete investigation of this incident showed that hydrogen induced cracking and not amine cracking was the primary cause [3], the incident prompted further actions on amine process equipment. One of the actions was a survey of cracking experience in amine service units. The survey results have been reported by Richert et al. [29]. The form used by NACE in the survey is included as Appendix C to this document.

Overall, the survey found about 40% cracking incidence in a total of 294 plants. Cracking had occurred in the absorber/contacter, the regenerator and the heat exchanger vessels, and in the piping and other auxiliary equipment. Several of the significant findings of the survey were:

- All cracks were in or near welds.
- Cracking occurred predominantly in unstress relieved (not PWHT) welds.
- Cracking occurred in processes using several kinds of amines but was most prevalent in MEA units.
- WFMT and UT were the predominant methods of detecting the cracks; internal examination by WFMT is the preferred method.

Information from laboratory studies of this problem by Lyle [30] and Schutt [31] indicate that pure amine does not cause cracking of carbon steels but amine with carbon dioxide in the gas phase causes severe cracking. The presence or absence of chlorides, cyanides, or hydrogen sulfide may also be factors but their full role in the cracking mechanism are not completely known at present.

Currently, API is preparing a Recommended Practice for vessels in amine service. It is expected to contain recommendations on the type and frequency of examination for cracking as well providing information on design, operating experience, and cracking mechanism. Preparation of the Recommended Practice is expected to be completed in 1988 or 1989.

### 6.3 Wet Hydrogen Sulfide Service

Wet hydrogen sulfide refers to any fluid containing water and hydrogen sulfide (H<sub>2</sub>S). Hydrogen is generated when steel is exposed to this mixture and the hydrogen can enter into the steel. As discussed earlier, the resulting dissolved hydrogen can cause cracking, blistering, and embrittlement. A recent article by Warren [32] provides a concise and informative discussion of the general and specific effects of hydrogen on steels.

The harmful effects of hydrogen generating environments on steel have been known and recognized for a long time in the petroleum and petrochemical industries. In particular, sensitivity to damage by hydrogen increases with the hardness and strength of the steel and damage and cracking are more apt to occur in high strength steels. To minimize this problem in equipment made of carbon steels and subject to wet H<sub>2</sub>S environments, both NACE and API have Recommended Practices [33,34] that gives a guideline limit on the hardness of the weld.

Recently, in line with the emphasis on improved and more thorough inspections being used on amine service equipment, the petroleum refining industry initiated an inspection program for vessels in wet H<sub>2</sub>S service. The suggested priorities and schedule for the inspection program is shown in Appendix D. Also, the WFMT method of examination was to be used. An interim report of the results which included the results for 189 vessels has been reported by Merrick [35]. Cracks of varying severity were detected in 31% of the vessels. This is a considerably higher incidence than was expected and is attributed in part to the use of WFMT, a more sensitive examination method.

The implications of the survey results are still being studied, but some of the findings from the survey and associated investigations are:

- Significant cracks can initiate from very small hard zones associated with weldments; these hard zones are not detected by conventional hardness tests.
- Initially small cracks can grow by a step-wise form of hydrogen blistering to form through thickness cracks.
- NACE/API limits on weld hardness may not be completely effective in preventing cracking.
- Thermal stress relief (PWHT) appears to reduce the sensitivity to and the severity of cracking.

Wet hydrogen sulfide has also been found to cause service cracking in liquefied petroleum gas (LPG) storage vessels. Cantwell [36] has reported on the results of a recent inspection survey which showed a 30% incidence of cracking for 141 inspected vessels. A considerable portion of the total found is attributed to preexisting fabrication flaws which are being detected by more sensitive inspection techniques such as WFMT. However, the results clearly show that inservice cracking has also occurred.

The service cracking in the LPG vessels occurs predominantly in the weld heat affected zone (HAZ). The vessels are usually spherical with wall thickness in the 20 to 75 mm (0.8 to 3 in) range. The vessel materials range from typical grades of carbon steels up to alloy steels with tensile strengths over 690 MPa (100 ksi).

The source of the hydrogen sulfide is believed to be carry-over ("breakthrough") from the treating process into the storage vessel. In common with the general trend of wet hydrogen sulfide cracking, the incidence in LPG

storage vessels is higher for the as-welded condition and for higher strength steels.

Cantwell [36] provides recommendations for new and existing vessels to minimize the risk of a major failure. Among these are:

- Use lower strength steels for new vessels.
- Schedule an early inspection for vessels more than 5 years in service.
- Improve monitoring to minimize breakthrough of hydrogen sulfide.
- Replace unsafe vessels or downgrade to less severe service; usually, lower pressure service.

#### 6.4 Ammonia Storage Service

Careful inspections of vessels used for storage of ammonia (in either vapor or liquid form) in recent years have resulted in evidence of serious stress corrosion cracking problems. Statistics reported at a meeting on this problem [37] indicate cracking in approximately one-half of the vessels examined.

The vessels for this service are usually constructed as spheres from one of the carbon steel grades, and they operate in the ambient temperature range.

The water and oxygen content in the ammonia has a strong influence on the propensity of carbon steels to crack in this environment. Figure 15 shows the U.S. and European guidelines for operation and inspection frequency.

Recent laboratory studies by Lunde and Nyborg [38] indicate general consistency with these guidelines.

The reported information indicates a tendency for the cracks to be in or near the welds in as-welded vessels. Cracks occur both transverse and parallel to the weld direction. Thermal stress relieving seems to be a mitigating procedure for new vessels, but its efficacy for older vessels after a period of operation is dubious partly because small, undetected cracks may be present.

#### 6.5 Pulp Digester Service

The kraft pulping process is used in the pulp and paper industry to digest the pulp in the papermaking process. The operation is done in a relatively weak (few percent) water solution of sodium hydroxide and sodium sulfide typically in the 110 to 140 °C (230 to 285 °F) temperature range. Since the early 1950s, a continuous version of this process has been widely used. Nearly all of the vessels are ASME Code vessels made using one of the carbon steel grades with typical design conditions of 175 to 180 °C (350 to 360 °F) and 1 MPa (150 psig).

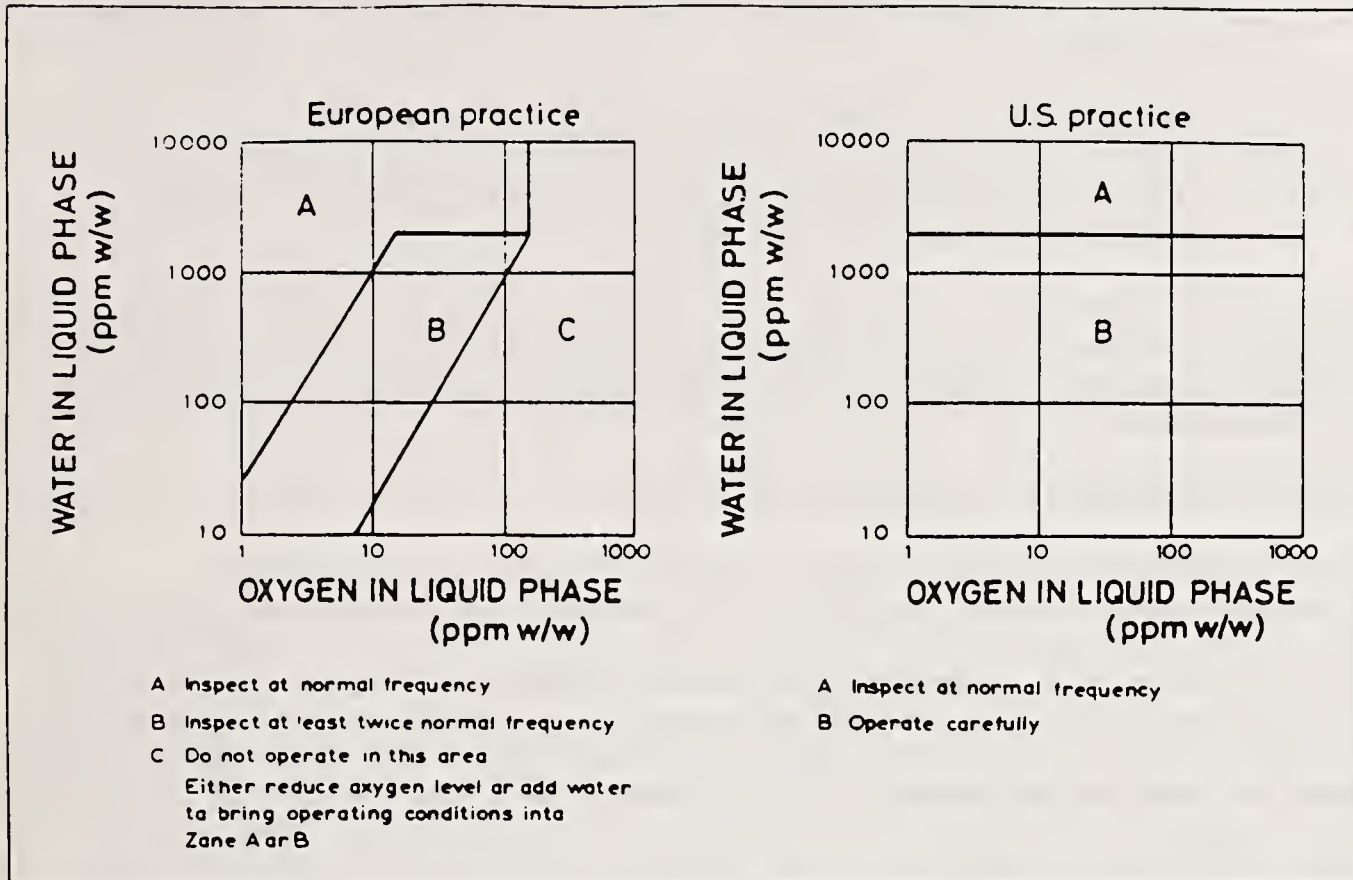

Figure 15. U.S. and European Guidelines for ammonia storage vessels [37].

These vessels had a very good service record with only isolated reports of cracking problems until the occurrence of a sudden rupture failure in 1980 [39]. Since then, TAPPI (Technical Association of the Pulp and Paper Industry) has organized and coordinated a program of inspection, determination of causes, and repair recommendations. The progress and results of this program have been summarized by Bennett [40].

The inspection survey has revealed that about 65% of the properly inspected vessels had some cracking. Some of the cracks were fabrication flaws revealed by the use of more sensitive inspection techniques but most of the cracking was service-induced. The inspection survey and analysis indicates the following features about the cracking:

- All cracking was associated with welds.
- Wet fluorescent magnetic particle (WFMT) testing with proper surface preparation was the most effective method of detecting the cracking.

- Fully stress relieved vessels were less susceptible.
- No clear correlation of cracking and non-cracking could be found with vessel age and manufacture or with process variables and practices.
- Analysis and research indicate that the cracking is due to a caustic stress corrosion cracking mechanism although its occurrence at the relatively low caustic concentrations of the digester process was unexpected.

Currently, preventive measures such as weld cladding, spray coatings, and anodic protection are being studied, and considerable information has been obtained [41]. In the meantime, the recommended guideline is to perform an annual examination.

#### 6.6 Summary of Service Cracking Experience

The preceding discussion shows a strong influence of chemical environmental conditions on cracking incidence. This is a factor that is not explicitly treated in most design codes. In fact, it would be difficult to include this factor in general design codes considering the wide variety of operating environments for various applications. Therefore, quantitative rules for the determination of the detrimental effects of various environments are not given in most design codes. Instead, service experience is the best and often the only guide to inservice safety assessment.

For vessels and tanks within the scope of this document, the service experience indicates that the emphasis of the inspection and safety assessment should be on:

- Vessels in deaerator, amine, wet H<sub>2</sub>S, ammonia and pulp digesting service,
- Welds and adjacent regions,
- Vessels that have not been thermally stress relieved (no PWHT of fabrication welds), and
- Repaired vessels, especially those without PWHT after repair.

The evaluation of the severity of the detected cracks can be done by fracture mechanics methods. This requires specific information about stresses, material properties, and flaw indications. Generalized assessment guidelines are not easy to formulate. However, fortunately, many vessels in the susceptible applications listed above operate at relatively low stresses, and therefore, cracks have a relatively smaller effect on structural integrity and continued safe operation.

## 7. PERIODIC INSPECTION REQUIREMENTS AND RECOMMENDATIONS

Rules and recommendations for periodic inservice inspection and evaluation can be very detailed and complete or relatively general and brief. Section XI of the ASME Code, "Rules For Inservice Inspection of Nuclear Power Plant Components," is an example of a very complete document with rules and requirements for inspection frequency, inspections methods, acceptability criteria, evaluation methods, and repair or replacement procedures. However, this is a special purpose document for a specific application. Of necessity, general application documents on inservice inspection have to be much more general in content and usually, shorter in length.

Several general documents on inservice inspection have already been mentioned. In addition, some recommendations developed for specific applications which have experienced serious cracking incidence have also been discussed. For consolidation and convenient reference, these requirements and recommendations are summarized in table III supplemented by additional remarks below.

### 7.1 National Board Inspection Code and API 510

These two are discussed together since the inservice inspection requirements of the two are similar; the specific documents are API 510 [12] and NBIC (National Board Inspection Code), [13]. Both documents are for general application and both cover rerating, alteration, and repair in addition to inservice inspection requirements. API 510 is intended for pressure vessels used in the refinery and petrochemical industries and NBIC is for all other applications.

API 510 and NBIC both use general corrosion rate as a guide for determining inspection frequency; the specific requirement is:

- The maximum period between inspections to be the lesser of one-half of the remaining corrosion life or 10 years.

The recommended examination method is the visual method augmented by other methods as appropriate.

Forms used by the National Board and by API to report the results of an inservice inspection of pressure vessels are included as Appendix E and F, respectively.

### 7.2 Recommendations for Specific Applications

Table III contains entries for several specific applications discussed earlier which have had significant cracking incidence in the past few years. The entries are not complete because some of the recommendations are still in preparation. Also, some of these are quite specific about inspection interval and frequency and examination method while others are more general. However, the table provides a good summary of guidelines for this important aspect of pressure vessel safety.

TABLE III  
SUMMARY OF INSPECTION GUIDELINES AND RECOMMENDATIONS

<u>Source</u>	<u>Application/ Environment</u>	<u>Interval for Internal Inspection</u>	<u>Recommended Method</u>	<u>Exam. Personnel Qualification</u>
NBIC and API 510	General	One-half of remaining corrosion life but no more than 10 years. If remaining life is less than 4 years, interval up to 2 years permitted. Exceptions for noncorrosive service.)	All appropriate methods	None specified
TAPPI and NACE	Deaerators	Initial inspection within 2 years. Reinspection within 2 years for repaired vessel, 1-2 years for cracked but un-repaired, 3-5 years for uncracked vessels	WFMT	ASNT Level I
API	Amine service	(In course of preparation)		
NBIC	Wet H <sub>2</sub> S	Recommends need for inspection, interval not specified	None recommended but WFMT used primarily	----
-----	Ammonia	As soon as possible	MT	----
TAPPI	Pulp digesters	Annually	WFMT or PT	----
Inst. of Petroleum	Process vessels	Initial inspection in first 2 years Reinspection: Grade 0, within 2 years Grade I, within 3 years Grade II, within 6 years Grade III, within 9 years	As appropriate	"Competent" Persons
Inst. of Petroleum	Storage vessels	Initial inspection in first 5 years Reinspection: Grade 0, within 5 years Grade I, within 5 years Grade II, within 7.5 years Grade III, within 10 years	As appropriate	"Competent" Persons



### 7.3 Institute of Petroleum Code

The last entry in table III lists information contained in a pressure vessel inspection code [42] used in the United Kingdom for the petroleum and chemical industries. Although this Code does not apply in the United States, one item in it is very pertinent. This is the item concerning the recommended frequency of inspection which is summarized in table III. Additional details of this part of the code are included in Appendix G.

The inspection frequency requirements of this Code are more specific than those in the API and National Board rules, and they are categorized by class of vessel and record of prior inspections. The first inservice inspection is required within the first 2/5 years of operation, depending on the class of vessel. Successive inspections can be at longer intervals if prior inspection results show a damage-free condition.

## 8. DAMAGE AND CRACK SEVERITY EVALUATION AND REPAIR

Assessing the severity of deterioration or cracks revealed by inservice inspections requires a thorough technical analysis. If the assessment indicates that a repair or modification is necessary to restore structural integrity, they need to be done with careful preparation and execution. Consideration of specific details for each vessel and application are required. Consequently, only some general and procedural guidelines are presented in this document.

### 8.1 Damage Evaluation

The proposed or tentative recommendations and guidelines for the cases of significant cracking described earlier are that if the depth of cracking or damage is less than the corrosion allowance, careful removal of the crack and blending the cavity with the surrounding is the recommended action.

If the damage depth is greater than the corrosion allowance, detailed engineering analysis is required to evaluate the options of allowing continued operation with the damage for some interval of service, removing the damage without repair, or repairing the damage. Fracture mechanics methodology for performing this type of evaluation was noted earlier. The evaluation should also include an analysis to determine whether further damage can be minimized by operational modifications.

### 8.2 Repair by Welding

If the technical evaluation indicates that a repair is necessary to restore structural integrity, welding is the usual method of repair. In the United States, weld repairing of vessels and tanks within the scope of this document will usually be done in accordance with the rules and requirements of API 510 [12] or the NBIC [13]. The major provisions for repair welding in these two codes are summarized in table IV.

TABLE IV  
SUMMARY OF NBIC AND API REPAIR WELDING REQUIREMENTS  
(NBIC - National Board Inspection Code, API - American Petroleum Inst. Std. 510)

<u>Activity</u>	<u>NBIC</u>	<u>API</u>
General Procedure	Per NBIC requirements	Follow principles of ASME Code
Authorized Repair Organizations	NB "R" Stamp holders, or ASME Stamp holders, or Jurisdiction authorized organization	ASME Stamp holders, or Owner-user self repair, or Qualified contractor, or Jurisdiction authorized organization
Authorization for Repair	By Inspector prior to proceeding except for "routine" repairs	By Inspector prior to proceeding
Acceptance of Repair	By Authorized Inspection Agency, or Owner-User Inspection Agency after completion	By Inspector after completion
Defect Repair Procedure	Complete removal of cracks Build-up of wasted areas permitted	Crack repairs require prior authorization Build-up of corroded areas
Weld Procedure and Welder Qualifications	In accordance with ASME IX	In accordance with the principles of ASME IX
Weld Procedure and Qualification Records	Maintain certified results	Maintain results
Weld Preheat	Per guidelines provided	Per ASME Code
PWHT	Per ASME Code	Per ASME Code
Alternative Weld and PWHT	No PWHT if high preheat used Temper (half bead) welds without PWHT permitted	No PWHT if high preheat used Permits temper bead welds without PWHT if witnessed
Replacement Materials	ASME Code materials; no welding for C more than 0.35%	Same as NBIC
Inspection	Per applicable ASME Code or acceptable alternative	Same as NBIC
Testing	Inspector may require pressure test	Same as NBIC
Documentation and Stamping	Completed Form R-1 and apply "R" stamp	Completed Alteration/Rerating form

Procedurally, both codes require that the repair plan be reviewed and certified by a registered or experienced engineer. Authorization to proceed with the repair is required from an Inspector and all welding must be done by qualified welders. In general, the repair weld should be postweld heat treated (PWHT), especially for vessels in cracking susceptible service. However, this may not always be possible and alternatives are provided in these codes.

Pressure vessels repaired according the NBIC rules are required to be marked with an "R" stamp by stamping or nameplate. Figure 16 shows the "R" symbol and the information required in the stamping.

**— STAMPING OR NAMEPLATE OF A BOILER  
OR PRESSURE VESSEL REPAIRED BY WELDING**

	<hr/> (name of repair firm)
No. <hr/> (National Board Repair symbol stamp no.)	<hr/> <hr/> [date of repair(s)]

Stamping or nameplate shall be applied adjacent to the original manufacturer's stamping or nameplate. A single nameplate or stamping may be used for more than one repair to a boiler or pressure vessel provided it is carried out by the same repair organization. The date of each repair shall be stamped on the nameplate. This date should correspond with the date on the Report of Welded Repairs. Letters shall be at least 5/32 in. (4 mm) high. (Ref. R-403, page 48.)

Figure 16. National Board Stamp or Nameplate for a weld repaired vessel.

In addition, the National Board requires the preparation and distribution of Form R-1, Report of Welded Repair or Alteration. A copy of this form is included as Appendix H. API does not have a formalized stamping to indicate repairs, but API 510 does require that the records of the repair be maintained by the owner or user of the vessel.

Overall, repair welds are usually made under less than ideal shop fabrication conditions, and careful attention to all aspects of welding must be exercised to avoid a condition that may be more prone to damage and deterioration.

#### 9. INFORMATION FOR SAFETY ASSESSMENT

This document has discussed a large amount of information on the design rules, inspection requirements, service experience, and damage mitigation relevant to pressure vessels and low pressure storage tanks used in general industrial applications. To serve as a summary and as a reminder, table V outlines the information and data that are necessary or useful to assess the safety and hazard implications of operating vessels and tanks.

#### 10. ACKNOWLEDGMENT

The assistance and helpful comments of Dr. H. I. McHenry of the National Institute of Standards and Technology, Boulder, Colorado in the preparation of this document are gratefully acknowledged. Thoughtful comments and remarks provided by OSHA personnel who reviewed a draft of this document are also acknowledged and greatly appreciated.

TABLE V  
INFORMATION AND DATA USEFUL FOR THE SAFETY ASSESSMENT OF STEEL  
VESSELS AND LOW PRESSURE STORAGE TANKS

INTRODUCTION AND SCOPE

This outline summarizes information and data that will be helpful in assessing the safety of steel pressure vessels and low pressure storage tanks that operate at temperatures between -75 and 315 °C (-100 and 600 °F).

VESSEL IDENTIFICATION AND DOCUMENTATION

Information that identifies the specific vessel being assessed and provides general information about it include the following items:

- Current Owner of the Vessel
- Vessel Location
  - Original location and current location if it has been moved
- Vessel Identification
  - Manufacturer's serial number
  - National Board number if registered with NB
- Manufacturer Identification
  - Name and address of manufacturer
  - Authorization or identification number of the manufacturer
- Date of Manufacture of the Vessel
- Data Report for the Vessel
  - ASME U-1 or U-2, API 620 form or other applicable report
- Date Vessel was Placed in Service
- Interruption Dates if not in Continuous Service

DESIGN AND CONSTRUCTION INFORMATION

Information that will identify the code or standard used for the design and construction of the vessel or tank and the specific design values, materials, fabrication methods, and inspection methods used include the following items:

- Design Code
  - ASME Code Section and Division, API Standard or other design code used
- Type of Construction
  - Shop or field fabricated or other fabrication method
- ASME VIII, Division 1 or 2 Vessels
  - Maximum allowable pressure and temperature
  - Minimum design temperature
- API 620 Vessels
  - Design pressure at top and maximum fill
  - Additional requirements included such as Appendix Q (Low-Pressure Storage Tanks For Liquefied Hydrocarbon Gases) and Appendix R (Low-Pressure Storage Tanks For Refrigerated Products)

TABLE V (con't.)

Other Design Code Vessels  
Maximum design and allowable pressures  
Maximum and minimum operating temperatures  
Vessel Materials  
ASME, ASTM or other specification names and numbers for the major parts  
Design Corrosion Allowance  
Thermal stress relief (PWHT, Postweld heat treatment)  
Design code requirements  
Type, extent, and conditions of PWHT performed  
Nondestructive Examination (NDE) of Welds  
Type and extent of examination performed  
Time when NDE was performed (before or after PWHT or hydrotest)

#### SERVICE HISTORY

Information on the conditions of the operating history of the vessel or tank that will be helpful in safety assessment include the following items:

Fluids Handled  
Type and composition, temperatures and pressures  
Type of Service  
Continuous, intermittent or irregular  
Significant Changes in Service Conditions  
Changes in pressures, temperatures, and fluid compositions and the dates of the changes  
Vessel History  
Alterations, reratings, and repairs performed  
Date(s) of changes or repairs

#### INSERVICE INSPECTION

Information about inspections performed on the vessel or tank and the results obtained that will assist in the safety assessment include the following items:

Inspection(s) Performed  
Type, extent, and dates  
Examination Methods  
Preparation of surfaces and welds  
Techniques used (visual, magnetic particle, penetrant test, radiography, ultrasonic)  
Qualifications of Personnel  
ASNT (American Society for Nondestructive Testing) levels or equivalent of examining and supervisory personnel  
Inspection Results and Report  
Report form used (NBIC NB-7, API 510 or other)  
Summary of type and extent of damage or cracking  
Disposition (no action, delayed action or repaired)

TABLE V (con't.)

SPECIFIC APPLICATIONS

Survey results indicate that a relatively high proportion of vessels in operation in several specific applications have experienced inservice related damage and cracking. Information on the following items can assist in assessing the safety of vessels in these applications:

Service Application

Deaerator, amine, wet hydrogen sulfide, ammonia or pulp digesting

Industry Bulletins and Guidelines For This Application

Owner/operator awareness of information

Type, Extent, and Results of Examinations

Procedures, guidelines and recommendations used

Amount of damage and cracking

Next examination schedule

Participation in Industry Survey for This Application

Problem Mitigation

Written plans and actions

EVALUATION OF INFORMATION

The information acquired for the above items is not adaptable to any kind of numerical ranking for quantitative safety assessment purposes. However, the information can reveal the owner or user's apparent attention to good practice, careful operation, regular maintenance, and adherence to the recommendations and guidelines developed for susceptible applications. If the assessment indicates cracking and other serious damage problems, it is important that the inspector obtain qualified technical advice and evaluation.

11. REFERENCES

- [1] Hammer, W., Occupational Safety Management and Engineering, 2nd ed., Prentice-Hall, 1981, Chapter 18, "Pressure Hazards."
- [2] ----, "Incident Report," published annually in April issue, National Board Bulletin, National Board of Boiler and Pressure Vessel Inspectors, Columbus, Ohio.
- [3] McHenry, H.I., Read, D.T. and Shives, T.R., "Failure Analysis of an Amine-Absorber Pressure Vessel," Mat. Perform., Vol. 26, Aug. 1987, pp 18-24.
- [4] ----, "Rules for Construction of Pressure Vessels," Section VIII, Divisions 1 and 2, ASME Boiler and Pressure Vessel Code, 1986 ed.
- [5] ----, "Recommended Rules for the Design and Construction of Large, Welded, Low-Pressure Storage Tanks," API 620, 7th ed., Sept. 1982, Rev. 1, April 1985.
- [6] Chuse, R., Pressure Vessels: The ASME Code Simplified, 6th ed., McGraw-Hill, 1984.
- [7] Yokell, S., "Understanding the Pressure Vessel Code," Chem. Eng. Vol. 93, No. 9, May 12, 1986, pp 75-85.
- [8] Selz, A., "New Toughness Rules in Section VIII, Division 1 of the ASME Boiler and Pressure Vessel Code," Mechanical Eng., Vol. 110, April 1988, pp 84-87.
- [9] Thielsch, H., Defects and Failures in Pressure Vessels and Piping, 2nd ed., Reinhold, 1975, Chaps. 16 and 17.
- [10] Logan, H.L., The Stress Corrosion of Metals, Wiley, 1966.
- [11] ----, "Nondestructive Examination," Section V, ASME Boiler and Pressure Vessel Code, 1986 ed.
- [12] ----, "Pressure Vessel Inspection Code," API 510, 4th ed., July, 1985.
- [13] ----, "National Board Inspection Code," National Board of Boiler and Pressure Vessel Inspectors, Columbus, Ohio, issued biennially.
- [14] ----, "Recommended Practice No. SNT-TC-1A," Amer. Soc. for Nondestructive Testing, Aug. 1984 ed.
- [15] McMaster, R.C., and McIntire, P. (eds.), Nondestructive Testing Handbook, 2nd ed., Vols. 1-5, Ronald Press, 1985-1987.
- [16] McGonnagle, R.C., Nondestructive Testing, 2nd. ed., Gordon and Breach, 1969.



- [17] ----, Guide for Inspection of Refinery Equipment, 2nd ed., Chapter IV, "Inspection Tools," API, 1976.
- [18] Bush, S.H., "Reliability of Nondestructive Examination," Vols. 1, 2 and 3, NUREG/CR-3110, U.S. Nuclear Regulatory Commission, Oct. 1983.
- [19] Robinson, J.O., "Deaerator Cracking Survey: Basic Design, Operating History and Water Chemistry Survey," NACE Corrosion 86, Paper No. 305.
- [20] Franco, R.J. and Buchheim, G.M., "Case Histories of Deaerator Failure Analyses," NACE Corrosion 86, Paper No. 306.
- [21] Winters, M.A., "An Oil Company's Overview of Deaerator Cracking," Mat. Perform., Vol. 25, Oct. 1986, pp 9-19.
- [22] Vormelker, P.R., "Deaerator Inspection and Analysis," NACE Corrosion 87, Paper No. 214.
- [23] Kelly, J.A., Guzi, C.E., and Laronge, T.M., "An Overview of NACE Task Group T-7H-7's Report on Deaerator Cracking," NACE Corrosion 88, Paper No. 350.
- [24] Herro, H.M., "Corrosion Fatigue and Deaerator Cracking," NACE Corrosion 87, Paper No. 213.
- [25] Copeland, J.F., Eastman, A.D., and Schmidt, C.G., "Fatigue and Stress Corrosion Cracking Evaluations in Deaerators," NACE Corrosion 87, Paper No. 216.
- [26] Gooch, T.G., "Review of Welding Practice for Carbon Steel Deaerator Vessels," Mat. Perform., Vol. 25, Dec. 1986, pp 30-38.
- [27] Beckwith, R.J., Sawtell, J.O., Stokes, H.A., and Yorgiadas, S., "System Design, Specifications, Operations and Inspection of Deaerators," Tappi Journ., Vol. 70, July 1987, pp 45-47.
- [28] ----, "Proposed Guidelines for Inspection of Boiler Feedwater Heater Vessels and Storage Tank Welds," Mat. Perform., Vol. 23, Nov. 1984, pp 65-66.
- [29] Richert, J.P., Bagdasarian, A.J., and Shargay, C.A., "Stress Corrosion Cracking of Carbon Steel in Amine Systems," Mat. Perform., Vol. 27, Jan. 1988, pp 9-18.
- [30] Lyle, F.F. Jr., "Stress Corrosion Cracking of Steels In Amine Solutions Used In Natural Gas Treatment Plants," NACE Corrosion 88, Paper No. 158.
- [31] Schutt, H.U., "New Aspects of Stress Corrosion Cracking In Monoethanolamine Solutions," NACE Corrosion 88, Paper No. 159.
- [32] Warren, D., "Hydrogen Effects on Steel," Mat. Perform., Vol. 26, Jan. 1987, pp 38-48.

- [33] ----, "Methods and Controls to Prevent In-Service Cracking of Carbon Steel Welds in P-1 Materials in Corrosive Petroleum Refining Environments," NACE Std. RP0472-87, 1974, Revised May 1987 (pub. in Mat. Perform., Vol. 26, Oct. 1987, pp 57-61).
- [34] ----, "Controlling Weld Hardness of Carbon Steel Refinery Equipment to Prevent Environmental Cracking," PUBL 942, 2nd ed., American Petroleum Institute, Nov. 1982.
- [35] Merrick, R.D., "Refinery Experience With Cracking in Wet H<sub>2</sub>S Environments," Mat. Perform., Vol. 27, Jan. 1988, pp 30-36.
- [36] Cantwell, J.E., "LPG Storage Vessel Cracking Experience," NACE Corrosion 88, Paper No. 157.
- [37] ----, "Panel Discussion on Stress-Corrosion Cracking in Ammonia Storage Spheres," Plant/Operations Progress, Vol. 2, Oct. 1983, pp 247-259.
- [38] Lunde, L. and Nyborg, R., "The Effect of Oxygen and Water on Corrosion Cracking of Mild Steel in Liquid and Vaporous Ammonia," Plant/Operations Progress, Vol. 6, Jan. 1987, pp 11-16.
- [39] Smith, K., "MacMillan Bloedel Digester Accident Shows Need for Frequent Inspection," Pulp and Paper, Oct. 1981, pp 66-69.
- [40] Bennett, D.C., "Cracking of Continuous Digesters: Review of History, Corrosion Engineering Aspects and Factors Affecting Cracking," Pulp and Paper Industry Corrosion Problems, Vol. 4, Proc. 4th Intl. Symp. on Corrosion in the Pulp and Paper Industry, Swedish Corrosion Inst., 1983.
- [41] Singbeil, D. and Garner, A., "A Test Method to Evaluate Stress Corrosion Cracking In Pressure Vessels," Mat. Perform., Vol. 27, Feb. 1988, pp 38-46.
- [42] ----, "Pressure Vessel Inspection Safety Code," Part 12, IP Model Code of Safe Practice in the Petroleum Industry, The Institute of Petroleum, London, 1976.

APPENDIX A - ASME CODE SECTION VIII, DIVISION 1 REPORT FORM

**FORM U-1 MANUFACTURER'S DATA REPORT FOR PRESSURE VESSELS**  
**As Required by the Provisions of the ASME Code Rules, Section VIII, Division 1**

1. Manufactured and certified by \_\_\_\_\_ (1) \_\_\_\_\_  
(Name and address of manufacturer)

2. Manufactured for \_\_\_\_\_ (2) \_\_\_\_\_  
(Name and address of purchaser)

3. Location of installation \_\_\_\_\_ (3) \_\_\_\_\_  
(Name and address)

4. Type \_\_\_\_\_ (5) \_\_\_\_\_ (8) \_\_\_\_\_ (9) \_\_\_\_\_ (10) \_\_\_\_\_ (12) \_\_\_\_\_  
(Material or specification) (Mfg. or serial No.) (CRN) (Drawing) (Matl. Bd. No.) (Year built)

5. The chemical and physical properties of all parts meet the requirements of material specifications of the ASME Boiler and Pressure Vessel Code. The design, construction, and workmanship conform to ASME Rules, Section VIII, Division 1 \_\_\_\_\_  
Year

\_\_\_\_\_ (13) \_\_\_\_\_ (14) \_\_\_\_\_ (15)  
Address (date) Code Case No. Special service per UG 120(d)

Items 6-11 incl. to be completed for single wall vessels, jackets of jacketed vessels, or shells of heat exchangers

6. Shell \_\_\_\_\_ (17) \_\_\_\_\_ (18) \_\_\_\_\_ (19) \_\_\_\_\_ (21) \_\_\_\_\_ (22) \_\_\_\_\_  
Matl. (Spec. No. Grade) Nom. Thk. (in.) Corr. Allow. (in.) Diam. (D. 1H & 1H) Length (Overall) (H & in.)

7. Seams \_\_\_\_\_ (23) \_\_\_\_\_ (24) \_\_\_\_\_ (24) \_\_\_\_\_ (25) \_\_\_\_\_  
Long. (Dbl. Sngl.) R.T. (Spot or Full) Eff. (%) H.T. Temp. (F.)

\_\_\_\_\_ (26) \_\_\_\_\_ (27) \_\_\_\_\_ (20)  
Time Girth (Dbl. Sngl.) R.T. (Spot Partial or Full) No. of Courses

B. Heads: (a) Matl. \_\_\_\_\_ (Spec. No. Grade) (b) Matl. \_\_\_\_\_ (Spec. No. Grade)

	Location (Top Bottom Ends)	Minimum Thickness	Corrosion Allowance	Crown Radius	Knuckle Radius	Elliptical Ratio	Conical Apex Angle	Hemispherical Radius	Flat Diameter	Side to Pressure (Convex or Concave)
(a)		(28)	(19)							
(b)										

If removable, bolts used (describe other fastenings) \_\_\_\_\_ (30) \_\_\_\_\_  
(Matl. Spec. No. Gr. Size No.)

9. Type of Jacket \_\_\_\_\_ (31) \_\_\_\_\_ Proof Test \_\_\_\_\_ (32) \_\_\_\_\_

10. Jacket Closure \_\_\_\_\_ (Describe as open & weld bar, etc.) if bar, give dimensions \_\_\_\_\_ If bolted, describe or sketch \_\_\_\_\_

11. MAWP \_\_\_\_\_ (34) \_\_\_\_\_ psi at max. temp. \_\_\_\_\_ (35) \_\_\_\_\_ °F. Min. temp. (when less than -20° F) \_\_\_\_\_ (36) \_\_\_\_\_ °F  
 Hydro., pneu., or comb. test press. \_\_\_\_\_ (37) \_\_\_\_\_ psi.

Items 12 and 13 to be completed for tube sections

12. Tubesheets \_\_\_\_\_ (17) \_\_\_\_\_ (21) \_\_\_\_\_ (18) \_\_\_\_\_ (19) \_\_\_\_\_  
Stationary Matl. (Spec. No. Gr.) Diam. (in.) (Subject to pressure) Nom. Thk. (in.) Corr. Allow. (in.) Attach. (Welded Bolted)

\_\_\_\_\_ (17) \_\_\_\_\_ (18) \_\_\_\_\_ (19) \_\_\_\_\_  
Floating Matl. (Spec. No. Gr.) Diam. (in.) Nom. Thk. (in.) Corr. Allow. (in.) Attach.

13. Tubes \_\_\_\_\_ (17) \_\_\_\_\_  
Matl. (Spec. No. Gr.) O.D. (in.) Nom. Thk. (in. or Gauge) Number Type (Straight or U)

Items 14-17 incl. to be completed for inner chambers of jacketed vessels or channels of heat exchangers

14. Shell \_\_\_\_\_ (17) \_\_\_\_\_ (18) \_\_\_\_\_ (19) \_\_\_\_\_ (21) \_\_\_\_\_ (22) \_\_\_\_\_  
Matl. (Spec. No. Grade) Nom. Thk. (in.) Corr. Allow. (in.) Diam. (D. 1H & 1H) Length (Overall) (H & in.)

15. Seams: \_\_\_\_\_ (23) \_\_\_\_\_ (24) \_\_\_\_\_ (24) \_\_\_\_\_ (25) \_\_\_\_\_  
Long. (Dbl. Sngl.) R.T. (Spot or Full) Eff. (%) H.T. Temp. (F.)

\_\_\_\_\_ (26) \_\_\_\_\_ (27) \_\_\_\_\_ (20)  
Time Girth (Dbl. Sngl.) R.T. (Spot Partial or Full) No. of Courses

16. Heads: (a) Matl. \_\_\_\_\_ (Spec. No. Grade) (b) Matl. \_\_\_\_\_ (Spec. No. Grade)

	Location (Top Bottom Ends)	Minimum Thickness	Corrosion Allowance	Crown Radius	Knuckle Radius	Elliptical Ratio	Conical Apex Angle	Hemispherical Radius	Flat Diameter	Side to Pressure (Convex or Concave)
(a)										
(b)										

If removable, bolts used (describe other fastenings) \_\_\_\_\_ (30) \_\_\_\_\_  
(Matl. Spec. No. Gr. Size No.)

17. MAWP \_\_\_\_\_ (34) \_\_\_\_\_ psi at max. temp. \_\_\_\_\_ (35) \_\_\_\_\_ °F. Min. temp. (when less than -20° F) \_\_\_\_\_ (36) \_\_\_\_\_ °F  
 Hydro., pneu., or comb. test press. \_\_\_\_\_ (37) \_\_\_\_\_ psi.

This Form (E00108) may be obtained from the ASME Order Dept., 22 Law Drive, Box 2300, Fairfield, NJ 07007-2300

APPENDIX A - ASME CODE SECTION VIII, DIVISION 1 REPORT FORM (Con't.)

Form U-1 (Back)

18. Nozzles, Inspection and Safety Valve Openings:

Purpose (Inlet Outlet Drain etc.)	No.	Diam or Size	Type	Mat't	Non Tha	Reinforcement Met	How Attached	Location
(38) (40)		(38)	(38)	(17)	(18)		(57)	(41)
			(57)	(55)	(55)			

19 Supports: Skirt (42) Lug (No) Leg (No) Other (Describe) Attached (Where and how)

20 Remarks: Manufacturer's Partial Date Reports properly identified and signed by Commissioned Inspectors have been furnished for the following items of the report

- (18) (23) (24) (25) (27) (28) (32) (37) (43) (51) (54)

**44 CERTIFICATE OF SHOP COMPLIANCE**

We certify that the statements made in this report are correct and that all details of design, material, construction, and workmanship of this vessel conform to the ASME Code for Pressure Vessels, Section VIII, Division 1

"U" Certificate of Authorization No. (45) expires 19\_\_\_\_

Date \_\_\_\_\_ Co. name \_\_\_\_\_ (44) \_\_\_\_\_ Signed \_\_\_\_\_ (44) \_\_\_\_\_  
(Manufacturer) (Representative)

**45 CERTIFICATE OF SHOP INSPECTION**

Vessel constructed by \_\_\_\_\_ at \_\_\_\_\_

I, the undersigned, holding a valid commission issued by the National Board of Boiler and Pressure Vessel Inspectors and/or the State or Province of \_\_\_\_\_ and employed by \_\_\_\_\_

of \_\_\_\_\_ have inspected the pressure vessel described in this Manufacturer's Date Report on \_\_\_\_\_, 19\_\_\_\_, and state that, to the best of my knowledge and belief, the Manufacturer has constructed this pressure vessel in accordance with ASME Code, Section VIII, Division 1. By signing this certificate neither the Inspector nor his employer makes any warranty, expressed or implied, concerning the pressure vessel described in the Manufacturer's Date Report. Furthermore, neither the Inspector nor his employer shall be liable in any manner for any personal injury or property damage or a loss of any kind arising from or connected with this inspection.

Date \_\_\_\_\_ Signed \_\_\_\_\_ (45) \_\_\_\_\_ Commissions \_\_\_\_\_ (47) \_\_\_\_\_  
(Authorized Inspector) (National Board, State, Province and No.)

**46 CERTIFICATE OF FIELD ASSEMBLY COMPLIANCE**

We certify that the field assembly construction of all parts of this vessel conforms with the requirements of Section VIII, Division 1 of the ASME Boiler and Pressure Vessel Code.

"U" Certificate of Authorization No. (46) expires 19\_\_\_\_

Date \_\_\_\_\_ Co. name \_\_\_\_\_ (46) \_\_\_\_\_ Signed \_\_\_\_\_ (46) \_\_\_\_\_  
(Assembler that certified and constructed field assembly) (Representative)

**49 CERTIFICATE OF FIELD ASSEMBLY INSPECTION**

I, the undersigned, holding a valid commission issued by the National Board of Boiler and Pressure Vessel Inspectors and/or the State or Province of \_\_\_\_\_ and employed by \_\_\_\_\_

of \_\_\_\_\_ have compared the statements in this Manufacturer's Date Report with the described pressure vessel and state that parts referred to as data items \_\_\_\_\_, not included in the certificate of shop inspection, have been inspected by me and that, to the best of my knowledge and belief, the Manufacturer has constructed and assembled this pressure vessel in accordance with ASME Code, Section VIII, Division 1. The described vessel was inspected and subjected to a hydrostatic test of \_\_\_\_\_ psi. By signing this certificate neither the Inspector nor his employer makes any warranty, expressed or implied, concerning the pressure vessel described in this Manufacturer's Date Report. Furthermore, neither the Inspector nor his employer shall be liable in any manner for any personal injury or property damage or a loss of any kind arising from or connected with this inspection.

Date \_\_\_\_\_ Signed \_\_\_\_\_ (49) \_\_\_\_\_ Commissions \_\_\_\_\_ (47) \_\_\_\_\_  
(Authorized Inspector) (National Board (incl. endorsements), State, Prov. and No.)

APPENDIX B - REPORT CONTENT FOR API STANDARD 620 LOW PRESSURE STORAGE TANK

**RECOMMENDED SCOPE FOR MANUFACTURER'S REPORT (See Par. 5.27)**

It is not the intent to set down rigid rules for the preparation of the manufacturer's report, inasmuch as the extent of the information which it contains, with the accompanying supplementary sketches, graphs of tests, and possibly special items wanted by the purchaser as shown on purchase orders, cannot possibly be listed here.

Although it is recommended that there be a certificate for each tank supplied, this is intended for simplification in keeping the records of future inspection in separate files for convenience. When a group of tanks is being constructed on one order and in one general location, some specific form of reporting other than a manufacturer's report may be preferred by both parties.

It would seem desirable that the details on each contract be settled when the purchase order is placed, if not in the proposal then as information given in the inquiry.

When parts of the structure are shop assemblies which are stress-relieved, as called for in Par. 3.25 and 4.18, the plans should so indicate in the customary general notes given thereon.

When more than minor repairs or changes and/or additions are made to the structure in the field for any reason, it is assumed that both the manufacturer and the purchaser will want to have a record thereof attached to the manufacturer's report.

A suggested wording for certification is:

**WE CERTIFY**, that the design, materials, construction, and workmanship on this low-pressure tank conform to the requirements of *API Standard 620: Recommended Rules for Design and Construction of Large, Welded, Low-Pressure Storage Tanks*.

Date \_\_\_\_\_ 19 \_\_\_\_\_ Signed \_\_\_\_\_ by \_\_\_\_\_  
(Manufacturer)

I have inspected the tank described in this manufacturer's report dated \_\_\_\_\_, and state that to the best of my knowledge the manufacturer has constructed this tank in accordance with the applicable sections of API Standard 620. The tank was inspected and subjected to a test of \_\_\_\_\_ psig.

Date \_\_\_\_\_ 19 \_\_\_\_\_ Inspector \_\_\_\_\_

**5.13 DATA REQUIRED FROM MANUFACTURER ON COMPLETED TANKS**

If specified in the purchase order, the manufacturer shall supply marked copies of plans (or a separate sketch) showing the location of all plates, with means of identifying each plate with the heat numbers, which markings shall be checked by the inspector. A copy shall be attached to the manufacturer's report.

**5.27 MANUFACTURER'S REPORT AND CERTIFICATE**

**5.27.1**

The manufacturer, upon completion of all tests and inspections on each tank, shall prepare a report summarizing all the data on the tank, including foundations if provided by him, and shall attach to the report all drawings and charts, as required by other paragraphs in this section of the rules (see Par. 5.13).

**5.27.2**

The manufacturer shall furnish and fill out a certificate for each tank, attesting that the tank has been constructed to these rules (see Appendix M). This certificate shall be signed by the manufacturer and the purchaser's inspector. This certificate, together with the official symbol placed on the tank, shall be a guarantee by the manufacturer that he has complied with all applicable requirements of these rules.

**5.27.3**

If the purchaser so requests, the manufacturer shall attach to the report copies of the records of the qualification test of welding procedures, of welders, and/or of welding operators (see Par. 4.07 and 4.08).

APPENDIX C - NACE AMINE CRACKING SURVEY QUESTIONNAIRE

CODE NO \_\_\_\_\_  
(assigned by NACE Headquarters)

It is recognized that in many locations several amine streams share a common regenerator. Fill out the questionnaire for each absorber/contactator and indicate the relationship with the regenerator.

I PROCESS

Type of plant: ammonia plant \_\_\_\_\_ chemical plant \_\_\_\_\_  
refinery \_\_\_\_\_ field production gas plant \_\_\_\_\_

Startup date \_\_\_\_\_ Unit design circulation rate  
(U.S. gpm) \_\_\_\_\_

Source of acid gas stream (i.e., what unit(s) does amine plant service) \_\_\_\_\_

Is feed stream: liquid \_\_\_\_\_ gas \_\_\_\_\_

Types of Amine Used      Range of      Acid Gas Loading      Acid Gas in Feed  
(dates)      Conc (%)      Mole Gas/Mole Amine      (Vol %)

Type	From (dates)	To	Lean	Rich	H <sub>2</sub> S	CO <sub>2</sub>

Is a reclaimer used? Yes \_\_\_\_\_ No \_\_\_\_\_  
(Reclaimer duty % of regenerator feed) \_\_\_\_\_

Reboiler: amine outlet temp (°F) \_\_\_\_\_  
heat medium temp (°F) \_\_\_\_\_

Quality of circulating amine: frequency of testing \_\_\_\_\_  
location of sample: rich \_\_\_\_\_ lean \_\_\_\_\_  
typical values: iron (ppm) \_\_\_\_\_  
Cl (ppm) \_\_\_\_\_  
cyanide \_\_\_\_\_  
TDS (ppm) \_\_\_\_\_  
Other \_\_\_\_\_

degradation products/heat stable salts (specify units) \_\_\_\_\_

Quality of reflux water: is it totally refluxed? yes \_\_\_\_\_ no \_\_\_\_\_  
Are filters used on amine stream? Yes \_\_\_\_\_ No \_\_\_\_\_ Type(s) of filter  
used? \_\_\_\_\_

Additives to amine\*: soda ash \_\_\_\_\_  
caustic soda: fresh \_\_\_\_\_ spent \_\_\_\_\_ comb \_\_\_\_\_  
injection point \_\_\_\_\_  
how is caustic level controlled? \_\_\_\_\_

Types of Inhibitors Used      Manufacturer/      Range of  
Type      From (dates)      To      Brand Name      Conc (ppm)      Injection Point

Type	From (dates)	To	Brand Name	Conc (ppm)	Injection Point

\*Please give as complete a history as possible, including additives used in the past. Please attach additional sheets of explanation if necessary.

This is general information necessary to gain data for both cracked and non-cracked equipment.

APPENDIX C - NACE AMINE CRACKING SURVEY QUESTIONNAIRE (Con't.)

II EQUIPMENT (carbon steel)

Complete the following table for stress relief (SR) history (use the following abbreviations for SR: F = at fabrication, L = Late, N = No).

<u>Equipment</u>	If Clad		<u>WELD TYPE</u>		
	<u>What Mat'l</u>	<u>butt</u>	<u>socket</u>	<u>seal</u>	<u>ext attachment</u>
Absorber/Contactor					
Regenerator					
Piping* Rich					
Lean					
Storage Tanks					
Lean/Rich					
Exchanger Shell					
Reboiler Shell					
Other Vessels					
Valves					
Pumps					

What is the maximum operating temp [°F] and press (psig) for:

absorber/contactor [ ] ( )

regenerator [ ] ( )

storage tank [ ] ( )

\*If using stainless piping, specify location and reason for use, (example: from regenerator to condenser because of corrosion).

III INSPECTION

	Absorber/ Contactor	Regenerator	<u>Piping</u>		Rich/Lean Tanks	Rich/Lean Exchanger
			Rich	Lean		
Years of amine service at last inspection						
Inspection Method <sup>1</sup>						
Surface Preparation <sup>2</sup>						

If AE was used, what was the method? standard triangulation \_\_\_\_  
special \_\_\_\_.

Have inspection methods been modified over life of piping/equipment?  
No \_\_\_\_ Yes \_\_\_\_ If yes, in what way and why? \_\_\_\_\_

- (1) Preface for external or internal inspection with small e or i and use the following abbreviations: VI = Visual Testing; UT(S) = ultrasonic shear wave; UT(L) = ultrasonic longitudinal wave; MT(B) = dry magnetic part; MT(W) = wet magnetic part; WFMT = wet fluorescent magnetic part; PT = dye penetrant; AE = acoustic emission; RT = radiographic testing.
- (2) Use following abbreviations: WB = wire brush; PB = power brush; SB = sandblast; CC = chemical cleaning.

APPENDIX C - NACE AMINE CRACKING SURVEY QUESTIONNAIRE (Con't.)

IV CLEANING TECHNIQUES AT SHUTDOWN

Is a water wash used before steamout? Yes  No

Has this plant been steamed out without a water wash? Yes  No   
 If yes, how many times? \_\_\_\_\_

Is any chemical cleaning used? Yes  No  Type: \_\_\_\_\_

During routine shutdown procedures do you transfer hot amine to tankage?  
 Yes  No

If yes, does amine transfer through lines or to tanks where you've reported cracking? Yes  No

VI CRACKING HISTORY\*

Have cracks been detected? Yes  No

Cause/method of crack detection: Leakage \_\_\_\_\_  
 Inspection: on stream \_\_\_\_\_ turnaround \_\_\_\_\_  
 Inspection: VT \_\_\_\_\_ UT(S) \_\_\_\_\_ UT(L) \_\_\_\_\_  
 MT(B) \_\_\_\_\_ MT(W) \_\_\_\_\_ WFMT \_\_\_\_\_  
 PT \_\_\_\_\_ RT \_\_\_\_\_ AE \_\_\_\_\_

Location of cracking (if convenient use back for sketch).

-type of equipment \_\_\_\_\_ age of equipment \_\_\_\_\_  
 -if cracks are in piping, specify location \_\_\_\_\_  
 -type of weld (e.g. internal attachment, opposite external weld, shell vertical, etc) \_\_\_\_\_  
 -was weld: shop \_\_\_\_\_ field \_\_\_\_\_ repair \_\_\_\_\_  
 -was crack transverse or parallel to weld? \_\_\_\_\_  
 -was crack associated with weld defects? Yes  No  Not known   
 If yes, please describe \_\_\_\_\_  
 -was crack location stress relieved? Yes  No  Time & temp if known \_\_\_\_\_  
 -what inspection techniques were used at fabrication at crack location? \_\_\_\_\_

Hardness at crack location \_\_\_\_\_ Method \_\_\_\_\_  
 Has metallography been performed? Yes  No ; if yes, were  
 cracks: (check as many as applicable)  
 branched  intergranular  transgranular  mixed mode   
 scale filled  type: oxide  sulfide  other (specify) \_\_\_\_\_

Process conditions at crack: normal process temp (°F) \_\_\_\_\_  
 max process temp (°F) \_\_\_\_\_  
 pressure (psig) \_\_\_\_\_  
 amine - rich \_\_\_\_\_  
 - lean \_\_\_\_\_

\*For multiple occurrences, please attach additional pages of explanation.

Was the failed component exposed to higher temperature amine than the maximum operating temperatures reported above (especially tankage and lines during shutting down procedures)? Yes  No

Material of construction at crack \_\_\_\_\_ Thickness (inches) \_\_\_\_\_  
 Was material lined or clad? Yes  No   
 How many cracks? \_\_\_\_\_ How deep? \_\_\_\_\_  
 Methods of repair: \_\_\_\_\_  
 Stress relieved after repair? Yes  No  Method (time and temp if known) \_\_\_\_\_



APPENDIX D - INSPECTION PRIORITIES FOR WET H<sub>2</sub>S CRACKING SURVEY

**TABLE 1 — Inspection program for equipment exposed to wet H<sub>2</sub>S > 50 wppm and cyanides > 20 wppm**

Equipment	Inspection
<b>Existing non-PWHT vessels</b>	
History of cracking, blistering, or HIC	WFMT, 100% of shell and head welds, internal attachment welds, and weld repairs/alterations at next scheduled turnaround
Previous welded repairs/alterations (with/without PWHT)	WFMT, 100% of weld repairs and alterations, and spot examination of other welds at the next scheduled turnaround
No prior welded repairs/alterations	WFMT on a spot basis of shell and head welds in selected vessels at next turnaround
<b>Existing PWHT vessels</b>	
History of cracking	WFMT, 100% of shell and head welds, internal attachment welds, and weld repairs/alterations at next scheduled turnaround.
History of blistering or HIC	WFMT, 100% of weld repairs and alterations, and spot examination of other welds at next scheduled turnaround
Previous welded repairs/alterations (with/without PWHT)	WFMT, 100% of weld repairs and alterations at next scheduled turnaround
No prior welded repairs/alterations	No special inspection required

**TABLE 2 — Inspection program for equipment exposed to wet H<sub>2</sub>S > 50 wppm**

Equipment	Inspection
<b>Existing non-PWHT vessels</b>	
History of cracking, blistering, or HIC	WFMT, 100% of shell and head welds, internal attachment welds, and weld repairs/alterations at next scheduled turnaround
Previous welded repairs/alterations (with/without PWHT)	WFMT, 100% of weld repairs and alterations of selected vessels at next scheduled turnaround.
No prior welded repairs/alterations	No special inspection required.
<b>Existing PWHT vessels</b>	
History of cracking.	WFMT, 100% of shell and head welds, internal attachment welds, and weld repairs/alterations at next scheduled turnaround
History of blistering or HIC.	WFMT, 100% of weld repairs and alterations, and spot examination of other welds at next scheduled turnaround.
Previous welded repairs/alterations (with/without PWHT)	WFMT, 100% of weld repairs and alterations of selected vessels at next scheduled turnaround
No prior welded repairs/alterations.	No special inspection required

APPENDIX E - NATIONAL BOARD'S INSPECTION REPORT FORM

**FORM NB-7 PRESSURE VESSELS**  
**REPORT OF INSPECTION**  
 Standard Form for Jurisdictions Operating Under the ASME Code

1	DATE INSPECTED MO DAY YEAR	CERT EXP DATE MO YEAR	CERTIFICATE POSTED <input type="checkbox"/> YES <input type="checkbox"/> NO	OWNER NO	JURISDICTION NUMBER	NAT'L BD NO <input type="checkbox"/> OTHER NO <input type="checkbox"/>
2	OWNER	NATURE OF BUSINESS		KIND OF INSPECTION <input type="checkbox"/> INT <input type="checkbox"/> EXT		CERTIFICATE INSPECTION <input type="checkbox"/> YES <input type="checkbox"/> NO
3	OWNER STREET ADDRESS NUMBER	OWNERS CITY		STATE	ZIP	
3	USERS NAME	OBJECT LOCATION	SPECIFIC LOCATION IN PLANT		OBJECT LOCATION	COUNTY
3	USERS STREET ADDRESS NUMBER	USERS CITY		STATE	ZIP	
4	TYPE <input type="checkbox"/> AIR TANK <input type="checkbox"/> WATER TANK <input type="checkbox"/> OTHER	YEAR BUILT	MANUFACTURER			
5	USE <input type="checkbox"/> STORAGE <input type="checkbox"/> PROCESS <input type="checkbox"/> HEAT EXCHANGE <input type="checkbox"/> OTHER	SIZE	PRESSURE GAUGE TESTED			
6	PRESSURE ALLOWED	SAFETY RELIEF VALVES		EXPLAIN IF PRESSURE CHANGED		
7	THIS INSPECTION	PREV INSPECTION	SET AT	TOTAL CAPACITY		
7	IS CONDITION OF OBJECT SUCH THAT A CERTIFICATE MAY BE ISSUED?				HYDRO TEST	PSI DATE
8	<input type="checkbox"/> YES <input type="checkbox"/> NO IF NO EXPLAIN FULLY UNDER CONDITIONS:				<input type="checkbox"/> YES <input type="checkbox"/> NO	
8	<b>CONDITIONS.</b> With respect to the internal surface describe and state location of any scale, oil or other deposits. Give extent and extent of any corrosion and state whether active or inactive. State location and extent of any erosion, grooving, bulging, warping, cracking, or other conditions. Report on any defective welds, flanges, loose or broken stays. State condition of all tubes, tube ends, coils, nipples, etc. Describe any special conditions with respect to pressure gauges, pressure gauges, glass gage cocks, safety valves, etc. Report condition of setting, levers, bellows, supports, etc. Describe any other damage or repairs made since last inspection.					
9	REQUIREMENTS (List any deficiencies)					
10	NAME AND TITLE OF PERSON TO WHOM REQUIREMENTS WERE EXPLAINED					
I HEREBY CERTIFY THIS IS A TRUE REPORT OF MY INSPECTION						
SIGNATURE OF INSPECTOR			IDENT NO	EMPLOYED BY	IDENT NO	

This form may be obtained from The National Board of Boiler and Pressure Vessel Inspectors, 1065 Crupper Ave., Col'a., OH 43229

NB-7  
Rev 2

APPENDIX F - API 510 REPORT FORM FOR INSPECTION RESULTS

**APPENDIX B—EXAMPLE OF INFORMATION FOR PRESSURE VESSEL INSPECTION RECORD**

FORM DATE \_\_\_\_\_  
 FORM NUMBER \_\_\_\_\_  
 OWNER OR USER \_\_\_\_\_  
 VESSEL NAME \_\_\_\_\_

**DESCRIPTION**

NAME OF PROCESS _____	OWNER OR USER NUMBER _____
LOCATION _____	JURISDICTION/NB NUMBER _____
INTERNAL DIAMETER _____	MANUFACTURER _____
TANGENT LENGTH/HEIGHT _____	MANUFACTURER'S SERIAL NO. _____
SHELL MATERIAL SPECIFICATION _____	DATE OF MANUFACTURE _____
HEAD MATERIAL SPECIFICATION _____	CONTRACTOR _____
INTERNAL MATERIALS _____	DRAWING NUMBERS _____
NOMINAL SHELL THICKNESS _____	DESIGN CODE _____
NOMINAL HEAD THICKNESS _____	JOINT EFFICIENCY _____
DESIGN TEMPERATURE _____	TYPE HEADS _____
MAXIMUM ALLOWABLE WORKING PRESSURE _____	TYPE JOINT _____
MAXIMUM HYDROTESTED PRESSURE _____	FLANGE CLASS _____
DESIGN PRESSURE _____	COUPLING CLASS _____
RELIEF VALVE SET PRESSURE _____	NUMBER OF MANWAYS _____
CONTENTS _____	WEIGHT _____
SPECIAL CONDITIONS _____	

SKETCH OR LOCATION DESCRIPTION	THICKNESS MEASUREMENTS						
	LOCATION NUMBER	ORIGINAL THICKNESS	REQ. MINIMUM THICKNESS	DATE			
COMMENTS DESCRIBE LOCATION RELATING TO THE COMMENT MADE	Method						
	Inspector						

Use additional sheets, as necessary .

APPENDIX G - INSTITUTE OF PETROLEUM CODE FREQUENCY OF PERIODIC INSPECTION

TABLE 2  
Class B Non-Statutory (UK only)

Equipment	Inspection Period (months)				
	Grade 0	Grade I	Grade II	Grade III	Review
Process Pressure Vessels and Process Vacuum Vessels	24	36	72	108	72
Pressure Storage Vessels	60	60	90	120	90
Heat Exchangers	24	36	72	108	72
Protective Safety Devices	24	36	60	—	—

**3.4 Inspection Grading Allocation for Class B Equipment**

**3.4.1 Inspection Grade 0**

All equipment shall be deemed to be in Grade 0 and shall remain in this Grade until a first thorough inspection is carried out, except as permitted in sections 4.5, 4.6 and 4.7.

**3.4.2 Inspection Grade I**

Equipment should be allocated to this Grade when the conditions of service are such that:

- (a) Deterioration in whole or in part is possible at a relatively rapid rate, or
- (b) There is little evidence or knowledge of operational effects on which to predict behaviour in service.

**3.4.3 Inspection Grade II**

Equipment should be allocated to this Grade when the conditions of service are such that:

- (a) Deterioration in whole or in part has been shown to be at a reasonable and predictable rate consistent with the increased inspection interval given for the item under this Grade, or
- (b) Evidence or knowledge of actual behaviour in service is sufficiently reliable to justify the inspection interval permitted by this Grade.

The intervals recommended in Table 2 are maxima. Intervals less than those allocated to Grade II but in excess of those allocated to Grade I may be stipulated if more appropriate to the conditions.

**3.4.4 Inspection Grade III**

Equipment may be allocated to this Grade, when the item has successfully concluded a period of service in Grade II and service conditions are such that:

- (a) Deterioration in whole or in part has been shown to be at a low and predictable rate consistent with the increased inspection interval given for the item in this Grade, or
- (b) Evidence and knowledge of actual service conditions are sufficiently accurate and reliable that an increased interval is justified.

The intervals recommended in Table 2 are maxima. Intervals less than the maxima for Grade III but in excess of those for Grade II may be stipulated where appropriate to the conditions.

Other factors to be considered in the choice of Grading are detailed in sections 4.7.2, 5.2 and 6.2.

**3.4.5 Inspection Review**

Equipment shall be subject to an Inspection Review when:

- (a) Registered items are allocated to Grade III inspection intervals. This is so that a reassessment may be made of the factors which led to a Grade III allocation being made and whether any changes have occurred since the last thorough inspection which may lead to a possible shortening of the interval which may be allowed to elapse to the next thorough inspection. (see sections 4.2.3 and 5.7.),
- (b) Significant changes take place in the conditions of service of any registered items in any Grading allocation which would affect its deterioration in whole or part, and
- (c) Following an abnormal incident which has or could have affected the safety of operation of the equipment.

APPENDIX H - NATIONAL BOARD REPORT FORM FOR WELD REPAIR OR ALTERATION

**FORM R-1, REPORT OF WELDED  REPAIR OR  ALTERATION**  
as required by the provisions of the National Board Inspection Code

1 Work performed by \_\_\_\_\_  
(name of repair or alteration organization) (P.O. no. job no. etc.)

\_\_\_\_\_ address

2 Owner \_\_\_\_\_  
name

\_\_\_\_\_ address

3 Location of installation \_\_\_\_\_  
name

\_\_\_\_\_ address

4 Unit identification \_\_\_\_\_ Boiler, pressure vessel Name of original manufacturer \_\_\_\_\_

5 Identifying nos. \_\_\_\_\_ (mit's serial no.) (original National Board no.) (jurisdiction no.) \_\_\_\_\_ year \_\_\_\_\_ month

6 Description of work \_\_\_\_\_  
(use back separate sheet or attach if necessary)

\_\_\_\_\_

\_\_\_\_\_

\_\_\_\_\_

7 Remarks: Attached are Manufacturers' Partial Data Reports properly identified and signed by Authorized Inspectors for the following items of this report: \_\_\_\_\_ Pressure vessel, etc. \_\_\_\_\_ DA

\_\_\_\_\_

\_\_\_\_\_

\_\_\_\_\_

\_\_\_\_\_ name of part, item number, mit's name and identifying stamp

**CERTIFICATE OF COMPLIANCE**

The undersigned certifies that the statements made in this report are correct and that all design, material, construction and workmanship on this \_\_\_\_\_ (repair or alteration) conform to the National Board Inspection Code.

Certificate of Authorization no. \_\_\_\_\_ to use the \_\_\_\_\_ symbol expires \_\_\_\_\_ 19 \_\_\_\_\_

Date \_\_\_\_\_ 19 \_\_\_\_\_ Signed \_\_\_\_\_ (authorized representative)

**CERTIFICATE OF INSPECTION**

The undersigned, holding a valid Commission issued by The National Board of Boiler and Pressure Vessel Inspectors and certificate of competency issued by the state or province of \_\_\_\_\_ and employed by \_\_\_\_\_ of \_\_\_\_\_ has inspected the work described in this data report on \_\_\_\_\_ 19 \_\_\_\_\_ and state that to the best of my knowledge and belief this work has been done in accordance with the National Board Inspection Code.

By signing this certificate, neither the undersigned nor my employer makes any warranty, expressed or implied, concerning the work described in this report. Furthermore, neither the undersigned nor my employer shall be liable in any manner for any personal injury, property damage or loss of any kind arising from or connected with this inspection, except such liability as may be provided in a policy of insurance which the undersigned's insurance company may issue upon said object and then only in accordance with the terms of said policy.

Date \_\_\_\_\_ 19 \_\_\_\_\_ Signed \_\_\_\_\_ Authorized Inspector \_\_\_\_\_ Commissioner \_\_\_\_\_ (National Board (INC) endorsement(s), state, prov. and no.)

This form may be obtained from The National Board of Boiler and Pressure Vessel Inspectors, 1066 Crupper Ave., Columbus, OH 43226 NS-88 Rev. 4

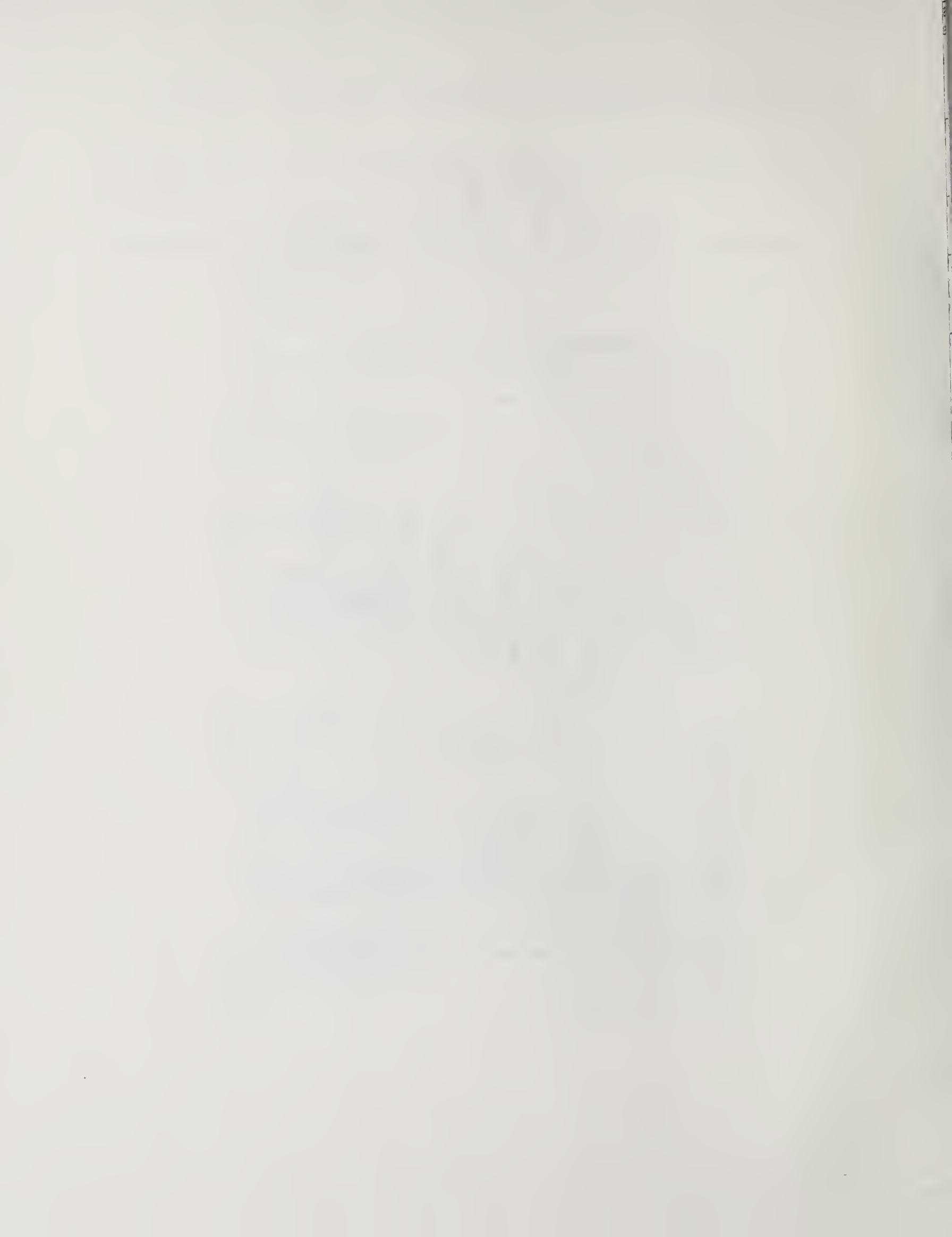

NIST-114A  
(REV. 3-89)

U.S. DEPARTMENT OF COMMERCE  
NATIONAL INSTITUTE OF STANDARDS AND TECHNOLOGY

# BIBLIOGRAPHIC DATA SHEET

1. PUBLICATION OR REPORT NUMBER  
NIST/SP-780

2. PERFORMING ORGANIZATION REPORT NUMBER

3. PUBLICATION DATE  
April 1990

4. TITLE AND SUBTITLE

Guidelines for Pressure Vessel Safety Assessment

5. AUTHOR(S)

Sumio Yukawa

6. PERFORMING ORGANIZATION (IF JOINT OR OTHER THAN NIST, SEE INSTRUCTIONS)

U.S. DEPARTMENT OF COMMERCE  
NATIONAL INSTITUTE OF STANDARDS AND TECHNOLOGY  
GAITHERSBURG, MD 20899

7. CONTRACT/GRANT NUMBER

8. TYPE OF REPORT AND PERIOD COVERED  
Final

9. SPONSORING ORGANIZATION NAME AND COMPLETE ADDRESS (STREET, CITY, STATE, ZIP)

Occupational Safety and Health Administration  
U.S. Department of Labor  
Washington, D.C. 20234

10. SUPPLEMENTARY NOTES

DOCUMENT DESCRIBES A COMPUTER PROGRAM; SF-185, FIPS SOFTWARE SUMMARY, IS ATTACHED.

11. ABSTRACT (A 200-WORD OR LESS FACTUAL SUMMARY OF MOST SIGNIFICANT INFORMATION. IF DOCUMENT INCLUDES A SIGNIFICANT BIBLIOGRAPHY OR LITERATURE SURVEY, MENTION IT HERE.)

This document presents a technical overview and information on metallic pressure containment vessels and tanks. The intent of the document is to provide OSHA (Occupational Safety and Health Administration) personnel and other persons with information to assist in the evaluation of the safety of operating pressure vessels and low-pressure storage tanks. The scope is limited to general industrial application vessels and tanks constructed of carbon or low alloy steels and used at temperatures between -75 and 315 °C (-100 and 600 °F). Information on design codes, materials, fabrication processes, inspection and testing applicable to these vessels and tanks are presented. The majority of these vessels and tanks are made to the rules and requirements of ASME Code Section VIII or API Standard 620. The causes of deterioration and damage in operation are described and methods and capabilities of detecting serious damage and cracking are discussed. Service experience in several applications where 30 to 50% incidence of cracking has been found is described. Guidelines and recommendations formulated by various groups to inspect for the damages being found and to mitigate the causes and effects of the problems are presented. A summary of the needed or useful information for the various factors and items involved in the safety of these vessels and tanks is included to assist in deciding whether further technical evaluation of safety concerns is required.

12. KEY WORDS (6 TO 12 ENTRIES; ALPHABETICAL ORDER; CAPITALIZE ONLY PROPER NAMES; AND SEPARATE KEY WORDS BY SEMICOLONS)

API Standards; ASME Code; design; failure; guidelines; inservice examination; nondestructive testing; pressure vessels; reliability; safety; service experience; steel.

13. AVAILABILITY

UNLIMITED  
FOR OFFICIAL DISTRIBUTION. DO NOT RELEASE TO NATIONAL TECHNICAL INFORMATION SERVICE (NTIS).  
  
 ORDER FROM SUPERINTENDENT OF DOCUMENTS, U.S. GOVERNMENT PRINTING OFFICE,  
WASHINGTON, DC 20402.  
 ORDER FROM NATIONAL TECHNICAL INFORMATION SERVICE (NTIS), SPRINGFIELD, VA 22161.

14. NUMBER OF PRINTED PAGES

75

15. PRICE













# **NIST** *Technical Publications*

## *Periodical*

---

**Journal of Research of the National Institute of Standards and Technology**—Reports NIST research and development in those disciplines of the physical and engineering sciences in which the Institute is active. These include physics, chemistry, engineering, mathematics, and computer sciences. Papers cover a broad range of subjects, with major emphasis on measurement methodology and the basic technology underlying standardization. Also included from time to time are survey articles on topics closely related to the Institute's technical and scientific programs. Issued six times a year.

## *Nonperiodicals*

---

**Monographs**—Major contributions to the technical literature on various subjects related to the Institute's scientific and technical activities.

**Handbooks**—Recommended codes of engineering and industrial practice (including safety codes) developed in cooperation with interested industries, professional organizations, and regulatory bodies.

**Special Publications**—Include proceedings of conferences sponsored by NIST, NIST annual reports, and other special publications appropriate to this grouping such as wall charts, pocket cards, and bibliographies.

**Applied Mathematics Series**—Mathematical tables, manuals, and studies of special interest to physicists, engineers, chemists, biologists, mathematicians, computer programmers, and others engaged in scientific and technical work.

**National Standard Reference Data Series**—Provides quantitative data on the physical and chemical properties of materials, compiled from the world's literature and critically evaluated. Developed under a worldwide program coordinated by NIST under the authority of the National Standard Data Act (Public Law 90-396). NOTE: The Journal of Physical and Chemical Reference Data (JPCRD) is published quarterly for NIST by the American Chemical Society (ACS) and the American Institute of Physics (AIP). Subscriptions, reprints, and supplements are available from ACS, 1155 Sixteenth St., NW., Washington, DC 20056.

**Building Science Series**—Disseminates technical information developed at the Institute on building materials, components, systems, and whole structures. The series presents research results, test methods, and performance criteria related to the structural and environmental functions and the durability and safety characteristics of building elements and systems.

**Technical Notes**—Studies or reports which are complete in themselves but restrictive in their treatment of a subject. Analogous to monographs but not so comprehensive in scope or definitive in treatment of the subject area. Often serve as a vehicle for final reports of work performed at NIST under the sponsorship of other government agencies.

**Voluntary Product Standards**—Developed under procedures published by the Department of Commerce in Part 10, Title 15, of the Code of Federal Regulations. The standards establish nationally recognized requirements for products, and provide all concerned interests with a basis for common understanding of the characteristics of the products. NIST administers this program as a supplement to the activities of the private sector standardizing organizations.

**Consumer Information Series**—Practical information, based on NIST research and experience, covering areas of interest to the consumer. Easily understandable language and illustrations provide useful background knowledge for shopping in today's technological marketplace.

*Order the above NIST publications from: Superintendent of Documents, Government Printing Office, Washington, DC 20402.*

*Order the following NIST publications—FIPS and NISTIRs—from the National Technical Information Service, Springfield, VA 22161.*

**Federal Information Processing Standards Publications (FIPS PUB)**—Publications in this series collectively constitute the Federal Information Processing Standards Register. The Register serves as the official source of information in the Federal Government regarding standards issued by NIST pursuant to the Federal Property and Administrative Services Act of 1949 as amended, Public Law 89-306 (79 Stat. 1127), and as implemented by Executive Order 11717 (38 FR 12315, dated May 11, 1973) and Part 6 of Title 15 CFR (Code of Federal Regulations).

**NIST Interagency Reports (NISTIR)**—A special series of interim or final reports on work performed by NIST for outside sponsors (both government and non-government). In general, initial distribution is handled by the sponsor; public distribution is by the National Technical Information Service, Springfield, VA 22161, in paper copy or microfiche form.

**U.S. Department of Commerce**

National Institute of Standards and Technology

(formerly National Bureau of Standards)

Gaithersburg, MD 20899

Official Business

Penalty for Private Use \$300