

7449
7-11-55
087
File Copy

NATIONAL BUREAU OF STANDARDS REPORT

7449

EFFECT OF BOILING OF THE INSULATION IN UNDERGROUND HEAT DISTRIBUTION SYSTEMS

by

Selden D. Cole and Paul R. Achenbach

Report to
Office of the Chief of Engineers
Bureau of Yards and Docks
Engineering Division, U.S. Air Force



U. S. DEPARTMENT OF COMMERCE
NATIONAL BUREAU OF STANDARDS

THE NATIONAL BUREAU OF STANDARDS

Functions and Activities

The functions of the National Bureau of Standards are set forth in the Act of Congress, March 3, 1901, as amended by Congress in Public Law 619, 1950. These include the development and maintenance of the national standards of measurement and the provision of means and methods for making measurements consistent with these standards; the determination of physical constants and properties of materials; the development of methods and instruments for testing materials, devices, and structures; advisory services to government agencies on scientific and technical problems; invention and development of devices to serve special needs of the Government; and the development of standard practices, codes, and specifications. The work includes basic and applied research, development, engineering, instrumentation, testing, evaluation, calibration services, and various consultation and information services. Research projects are also performed for other government agencies when the work relates to and supplements the basic program of the Bureau or when the Bureau's unique competence is required. The scope of activities is suggested by the listing of divisions and sections on the inside of the back cover.

Publications

The results of the Bureau's research are published either in the Bureau's own series of publications or in the journals of professional and scientific societies. The Bureau itself publishes three periodicals available from the Government Printing Office: The Journal of Research, published in four separate sections, presents complete scientific and technical papers; the Technical News Bulletin presents summary and preliminary reports on work in progress; and Basic Radio Propagation Predictions provides data for determining the best frequencies to use for radio communications throughout the world. There are also five series of non-periodical publications: Monographs, Applied Mathematics Series, Handbooks, Miscellaneous Publications, and Technical Notes.

A complete listing of the Bureau's publications can be found in National Bureau of Standards Circular 460, Publications of the National Bureau of Standards, 1901 to June 1947 (\$1.25), and the Supplement to National Bureau of Standards Circular 460, July 1947 to June 1957 (\$1.50), and Miscellaneous Publication 240, July 1957 to June 1960 (Includes Titles of Papers Published in Outside Journals 1950 to 1959) (\$2.25); available from the Superintendent of Documents, Government Printing Office, Washington 25, D. C.

NATIONAL BUREAU OF STANDARDS REPORT

NBS PROJECT

NBS REPORT

1000-12-10401

February 23, 1962

7449

EFFECT OF BOILING OF THE INSULATION IN UNDERGROUND HEAT DISTRIBUTION SYSTEMS

by

Selden D. Cole and Paul R. Achenbach
Mechanical Systems Section
Building Research Division

to

Office of the Chief of Engineers
Bureau of Yards and Docks
Engineering Division, U.S. Air Force

IMPORTANT NOTICE

NATIONAL BUREAU OF STANDARDS
Intended for use within the
to additional evaluation and
listing of this Report, either
the Office of the Director, NIST
however, by the Government
to reproduce additional copies

Approved for public release by the
Director of the National Institute of
Standards and Technology (NIST)
on October 9, 2015.

progress accounting documents
ormally published It is subjected
; reproduction, or open-literature
ssion is obtained in writing from
Such permission is not needed,
/ prepared if that agency wishes



U. S. DEPARTMENT OF COMMERCE
NATIONAL BUREAU OF STANDARDS

EFFECT OF BOILING OF THE INSULATION IN UNDERGROUND HEAT DISTRIBUTION SYSTEMS

by
Selden D. Cole and Paul R. Achenbach

ABSTRACT

Simulated field tests were made with several different types of insulation used for underground heat distribution systems to study the effect of boiling the insulation in the conduit on the heat transmission rate and the physical condition of the insulation. This test procedure was developed as a method for determining the deleterious effect of boiling insulation materials in an underground conduit in terms of the increase of the heat transmission rate rather than an evaluation of the deterioration in terms of loss of insulation, cracking, swelling, spalling, erosion, or other chemical or physical changes. The heat transmission rate of the conduit was determined for new insulation before boiling and at the end of each of three 72-hour periods of boiling, with the insulation dry for each determination. The heat transmission rate of the uninsulated conduit was also determined. The tests were conducted with the steam pipe in the conduit maintained at a temperature of approximately 350° F during both the boiling periods and the periods when the steady state heat transmission rate of the dry insulation was being measured. The results showed that the heat transmission rates of glass fiber and rigid cellular glass insulations increased significantly with increased exposure to boiling, whereas that for calcium silicate insulation did not change appreciably. The various insulations used on the bare pipe reduced the heat transmission rate of the system to approximately one-third of the value obtained with the uninsulated pipe when the insulation was new and dry. After boiling for three periods of 72 hours each, the heat transmission rate of the insulated conduit had increased to more than one-half the rate for the uninsulated conduit, except for calcium silicate which remained about the same.

EFFECT OF BOILING OF THE INSULATION IN UNDERGROUND HEAT DISTRIBUTION SYSTEMS

1. Introduction

As a part of the Tri-Service Engineering Investigations of Building Construction and Equipment sponsored at National Bureau of Standards by the Corps of Engineers, Department of the Army; Bureau of Yards and Docks, Department of the Navy; and Engineering Division, Department of the Air Force, a study was made to determine the change in heat loss of a simulated underground heat distribution system caused by prolonged boiling of the insulation in the conduit.

Experience has revealed that the insulation space of an underground heat distribution system may be flooded periodically with drainage water caused by rain, or by an internal leak in the steam or high temperature water piping. If the heating pipe remains under pressure when the flooding occurs, the water in the insulation space will boil and subject the insulation to the effects of high temperature water, superheated steam, and to the mechanical action of the boiling process which will usually cause progressive deterioration of the insulation. The deterioration of various insulating materials has been studied in the laboratory under conditions simulating such flooded situations. For this study, the insulation inside the conduit was subjected to three boiling periods of 72 hours each under specified test conditions. The steady heat loss of the system was determined on the new specimen before boiling and again after each of the three boiling periods, with the insulation dry in each case, to reveal the rate of deterioration of the insulation in terms of change in heat transfer rate.

2. Description of Test Apparatus

A 20-foot section of conduit was used for the tests, consisting of a nominal 4-inch steam pipe enclosed in the insulation to be tested and in a welded metal conduit sufficiently large to provide a 1-inch annular air space between the conduit and the exterior of the insulation. The 4-inch steam pipe extended about 3 inches beyond the end of the metal conduit at each end. Two different sizes of conduit were used for the study because of the difference in the thickness of one of the insulating materials.

The apparatus used for the boiling test is illustrated diagrammatically in Figure 1. The apparatus consisted of a reinforced plywood box for supporting and enclosing the conduit specimen, immersion electric resistance heaters for determining the heat transfer rate, a steam boiler, and the necessary piping, gages, and controls for conducting the test. The plywood box measured 4 ft x 4 ft x 19 ft 4 in. in size, with an open top. During the test the top was covered with a sheet of plastic to control random circulation of air around the specimen. The conduit specimen was supported in a level position along the longer axis of the box and projected through holes cut in each end of the box to fit the exterior of the conduit. The conduit extended about 3 inches beyond either end of the box. The conduit was wrapped with a blanket of glass fiber insulation 1/4 in. thick and stapled together at the lapped joints to simulate the thermal resistance of approximately 2 ft of earth cover.

The ends of the conduit were closed with metal plates, one of which was welded to the conduit and the other was flanged and secured with bolts. The joints between the end plates and the exterior of the 4-inch steam pipe were fitted with gland seals to prevent leakage. Holes for 1-inch pipe were provided at the top and bottom of each of the end plates and one of the end plates was provided with two additional holes for 1/4-inch pipe for attachment of a sight glass. The 1-inch pipe connections at the top and bottom of the end plates were used for filling and draining, for venting of steam, and for attachment of a pressure gage, as required. The details of the end plates and the openings in them are illustrated in Figure 1.

The 4-inch steam pipe was operated as a closed boiler with immersion electric heating elements during the periods when the heat transmission rate of the specimen was being measured. Conventional pipe flanges were attached to the threaded ends of the 4-inch pipe. Steel plates 3/4 inch thick were bolted to the flanges at each end. Each of these plates was drilled and tapped to receive a 2-element immersion electric heater located along the center line of the pipe. In addition, holes for 1/4-inch pipe were drilled and tapped at the top and bottom of each of the steel plates such that they were approximately tangent to the interior surface of the 4-inch pipe. A third hole was provided near the top of the pipe in either end to establish the water level when the pipe was being used as an electric boiler.

The immersion electric heaters consisted of two hairpin elements each with a maximum capacity of 3,000 watts. The four elements were wired to provide individual control and each element was connected to a separate watt-hour meter through a disconnect switch. One heater element in each end was connected

directly to the power supply and the other element in each end was actuated by a pressure control connected to the 4-inch pipe. The power supply was arranged so that either 230 volts or 115 volts could be applied to the heating elements. A second pressure control served as a safety device and was used to disconnect all of the electric heaters by means of a magnetic switch if the pressure reached some selected value a little above the operating pressure level.

Additional plywood boxes were built around the ends of the conduit that projected through the main box. These boxes were filled with granular perlite insulation during the electric heat transmission test to reduce the heat transfer from the end flanges and other fittings to a very small value.

A steel boiler of about 1,000,000 Btu/hr heating capacity was connected to the 4-inch steam pipe during the boiling cycles since the electric heaters were of inadequate capacity for this purpose.

For the boiling test, the steel plates containing the electric immersion heaters were replaced by two other steel plates. One of these two plates was drilled at its center and fitted with a 1 1/2-inch pipe. This pipe extended into the 4-inch steam pipe about 18 inches and projected about 6 inches beyond the steel plate on the outside. The inner end of the 1 1/2-inch pipe was capped, and enough 1/4-inch holes were drilled through the sides of this 18-inch projection to comprise a cross section area which exceeded the cross section area of the 1 1/2-inch pipe. The other end of the 1 1/2-inch pipe was connected to the steam boiler. The steel plate on the other end of the 4-inch pipe was provided with a hole for a 1/4-inch pipe at the top, and a second hole for a 3/4-inch pipe at the bottom. The upper connection was used as an air vent and as a connection for a pressure gage. The 3/4-inch pipe connection was used to remove condensate. This pipe was connected to a steam trap and to a water-cooled heat exchanger to cool the condensate to room temperature. The ends of the conduit were not insulated during the boiling cycles.

3. Description of Insulating Materials

In this investigation, the heat transfer rate of the conduit specimen was studied with the 4-inch pipe bare and also covered with each of four different types of pipe insulation, as follows: (1) glass fiber blanket of 7 1/2 lbs/ft³ density formed into annular sections 2 feet long with walls 1 1/2 inches thick. The annular sections of insulation were wrapped with a plastic-coated Fiberglas netting resembling window screen as fabricated by the Ric-Wil Corporation; (2) split sections of calcium silicate insulation of 11 lbs/ft³ density, 36 inches long and with a wall

thickness of 1 1/2 inches as manufactured by the Johns-Manville Company and marketed as Thermobestos; (3) split sections of cellular glass insulation of about 8.5 lbs/ft³ density, 18 inches long with a wall thickness of 2 1/2 inches as manufactured by the Pittsburgh Corning Corporation and marketed as FoamGlas Pipe Insulation; (4) split sections of premolded glass fiber insulation of about 3 1/2 lbs/ft³ density, 36 inches long with a wall thickness of 1 1/2 inches as manufactured by the Gustin-Bacon Company and marketed as Molded Glasfiber Pipe Insulation. These materials were obtained from the manufacturers and were materials being sold for insulation of underground heating pipes.

4. Test Procedure

At the beginning of a test the 4-inch pipe was operated as a closed steam boiler, using the energy consumption of the electric immersion heaters to determine the heat transmission rate of the conduit specimen when new and before any boiling of the insulation occurred. To prepare for this test, all openings in the conduit flanges except one vent were closed, the 4-inch pipe was completely filled with water, leaving one of the openings in the end flange at the top of the pipe open for escape of air. When the pipe had been filled, the vent was closed and the electric heaters were energized at a low rate of heat input. One of the openings, about a half inch from the top of the pipe, was opened slightly through a valve and water was allowed to escape slowly as expansion occurred and as the steam pressure built up. When steam only began to escape from this opening, it was assumed that the water level had reached the level of the opening and the valve was closed completely. The steam pressure was then raised to approximately 125 lbs/in.² gage to attain a steam pipe temperature of 350° F. A thermocouple peened into the 4-inch pipe at one end was used as an indicator for setting the pressure control for the electric heating elements. Thereafter, the pressure in the steam pipe was kept constant and the energy input to the electric heaters was observed at regular intervals. The heat transmission test was terminated when the heat transfer rate, as measured by the electric energy used, had been steady for 24 hours.

After the steady state heat loss of the specimen was determined, the electric heaters were removed and the alternate steel plates were bolted to the flanges on the 4-inch steam pipe thus permitting the boiler to provide steam for the system.

The steam trap and heat exchanger were connected to the outlet end of the 4-inch pipe. The insulation space of the conduit was filled with water to saturate the insulation, after which

enough water was drained out to lower the level to the half-full mark, as indicated by the sight glass.

Steam from the boiler was admitted to the 4-inch pipe to raise the gage pressure to approximately 125 lb/in.² as rapidly as possible. The steam pressure was maintained essentially constant for a period of 72 hours during which the water in the insulation space boiled vigorously. The steam produced in the insulation space was allowed to escape from one of the vents in the end plate, and cold water was fed into the insulation space to maintain a constant water level.

At the end of 72 hours of boiling, the water was drained from the insulation space, the steam boiler and steam trap were disconnected from the 4-inch pipe, and the alternate steel plates containing the electric resistance heaters were again attached to the pipe. The 4-inch pipe was operated again as a closed steam boiler at a pressure of 125 lb/in.² to gradually dry out the insulation. The drying test was continued until a new value for steady state heat transfer rate was obtained.

Three such cycles of boiling and drying were carried out following this procedure. The effect of the boiling on the insulating quality of the materials could then be expressed in terms of the change in heat transfer rate related to the length of time that it had been boiled. The insulated steam pipe was removed from the conduit for inspection and photographing at the end of the third boiling and drying cycle.

In separate tests the heat transfer rate of the two sizes of conduit without insulation on the 4-inch steam pipe was determined by operating the steam pipe as a closed steam boiler.

5. Test Results and Discussion

A summary of the heat transfer of the 20-foot section of conduit with each of the four types of insulation and without any insulation is presented in Table 1 and the results are shown graphically in Figure 2. The graph shows a progressive increase in heat transfer rate with longer exposure to boiling conditions for the two types of glass fiber and the cellular glass insulations, but very little increase in heat transfer rate for the calcium silicate insulation throughout the 216 hours of boiling. Table 1 shows that the increase in heat transfer rate as a result of boiling the insulation in the conduit for 216 hours ranged from less than 10 percent for the calcium silicate material up to 90 percent for the preformed glass fiber blanket wrapped in the glass fiber screen.

Table 1

HEAT TRANSFER OF A SECTION OF UNDERGROUND CONDUIT SYSTEM
BEFORE AND AFTER BOILING THE INSULATION IN THE CONDUIT

Test No.	Specimen and Condition	Heat Loss of 20-ft System KWH/hr	Btu/hr	Btu/hr(ft)	Heat Loss % of New Value
1	4-in. Bare pipe - 10-in. Conduit	1.596	5450	272.5	---
2	4-in. Bare pipe - 12-in. Conduit	1.793	6124	304.1	---
3	Ric-Wil Preformed Fiberglas Blanket in 10-in. Conduit - New condition	.508	1735	86.8	100
4	After 1st. 72 hours boiling	.600	2049	102.5	118
5	After 2nd. 72 hours boiling	.811	2770	138.5	160
6	After 3rd. 72 hours boiling	.964	3290	164.5	190
7	Gustin-Bacon Molded Glass Fiber in 10-in. Conduit - New condition	.516	1763	88.1	100
8	After 1st. 72 hours boiling	.562	1919	95.9	109
9	After 2nd. 72 hours boiling	.617	2110	105.5	120
10	After 3rd. 72 hours boiling	.828	2828	141.4	161
11	Johns-Manville Thermobestos (Calcium Silicate) in 10-in. Conduit - New condition	.567	1936	96.8	100
12	After 1st 72 hours boiling	.594	2028	101.4	105
13	After 2nd. 72 hours boiling	.578	1975	98.8	102
14	After 3rd. 72 hours boiling	.600	2048	102.4	106
15	Pittsburgh Corning FoamGlas in 12-in. Conduit - New condition	.628	2144	107.0	100
16	After 1st. 72 hours boiling	.743	2538	127.9	120
17	After 2nd. 72 hours boiling	.845	2882	144.0	135
18	After 3rd. 72 hours boiling	.942	3217	160.8	150

Table 1 shows that the four types of insulation, in the thicknesses used for these studies, reduced the heat transfer rate of the conduit section to a value ranging from 31.8 to 35.5 percent of the heat transfer rate of the conduit without insulation. Thus the insulating effect was approximately equivalent in each case. At the end of the 216 hours of boiling the heat transfer rate of the conduit section ranged from 37.6 percent for the calcium silicate material to 60.4 percent for the preformed glass fiber blanket of the corresponding value for the uninsulated conduit.

The measured heat loss shown in Table 1 was assumed to represent the heat loss of a 20-foot section of conduit. However, it more nearly represents the heat loss of 19 1/2 feet of conduit because of the thick layer of perlite insulation that surrounded the ends of the conduit which projected through the supporting box. The insulating effect at the ends was kept constant for all tests so the unit values of heat loss for the conduit as reported in Table 1 are comparable values.

The physical condition of the four insulating materials at the end of the three cycles of boiling and drying is indicated in Figure 3-10 inclusive.

Figures 3 and 4 are photographs of the preformed fiber glass blanket insulation. Both figures show significant portions of the steam pipe devoid of insulation even though the glass fiber wrapper remained intact. The leaching action of the boiling water and superheated steam embrittled the fibers and pulverized them into a powdery dust which sifted through the wrapper and was deposited on the lower inside surface of the conduit.

Figures 5 and 6 are photographs of the molded glass fiber insulation. It was not enclosed in a wrapper but was secured to the pipe with two bands per section. Figure 5 is a full length view of the test section which indicates that the maximum damage occurred approximately at the water line and that portions of insulation of limited size were completely dislodged from the steam pipe. Figure 6 is a close-up view of the damage to the left of the center spacing ring in Figure 5, which shows that the loss of insulation occurred principally at the longitudinal and circumferential joints. Some embrittlement and powdering of the glass fibers also occurred in this insulation near the surface of the steam pipe, but not to the same degree as for the blanket glass fiber material.

Figures 7 and 8 are photographs of the Thermobestos calcium silicate insulation. Figure 7 is a full length view of the specimen revealing only a limited amount of surface spalling of the material. Figure 8 is a close-up view showing limited erosion and loss of material at the longitudinal and circumferential joints. In no case did the erosion extend the full thickness of the insulation.

Figures 9 and 10 are photographs of the cellular glass insulation. Both figures show extensive cracking of the cellular glass in every section of insulation. The cracking of the insulation could be heard during the heating up period at the beginning of each of the boiling cycles. The broken pieces of insulation probably did not fall clear of the steam pipe while it was still inside the conduit because there was only 1-inch clearance between the bottom of the insulation and the bottom of the conduit. However, if the broken pieces dropped down to the bottom of the conduit the water would have increased access to the steam pipe causing a greater heat loss.

This test procedure was developed as a method for measuring the deleterious effect of boiling insulating materials in an underground conduit in terms of the increase in the heat transmission rate rather than a less quantitative evaluation of the deterioration in terms of loss of insulation, cracking, swelling, spalling, erosion, or other chemical or physical changes. In addition, it provides a measure of the heat transfer rate of a conduit with the insulation in new condition. Using a 1/4-inch wrapper of glass fiber blanket on the exterior of the conduit to simulate the insulating effect of an earth cover reduces greatly the time required to attain a steady state heat loss. It evaluates the effectiveness of an insulated conduit in terms of its heat transmission rate which is the most significant characteristic associated with the purpose of insulation.

AN APPARATUS FOR STUDYING THE EFFECT OF BOILING ON PIPE INSULATION

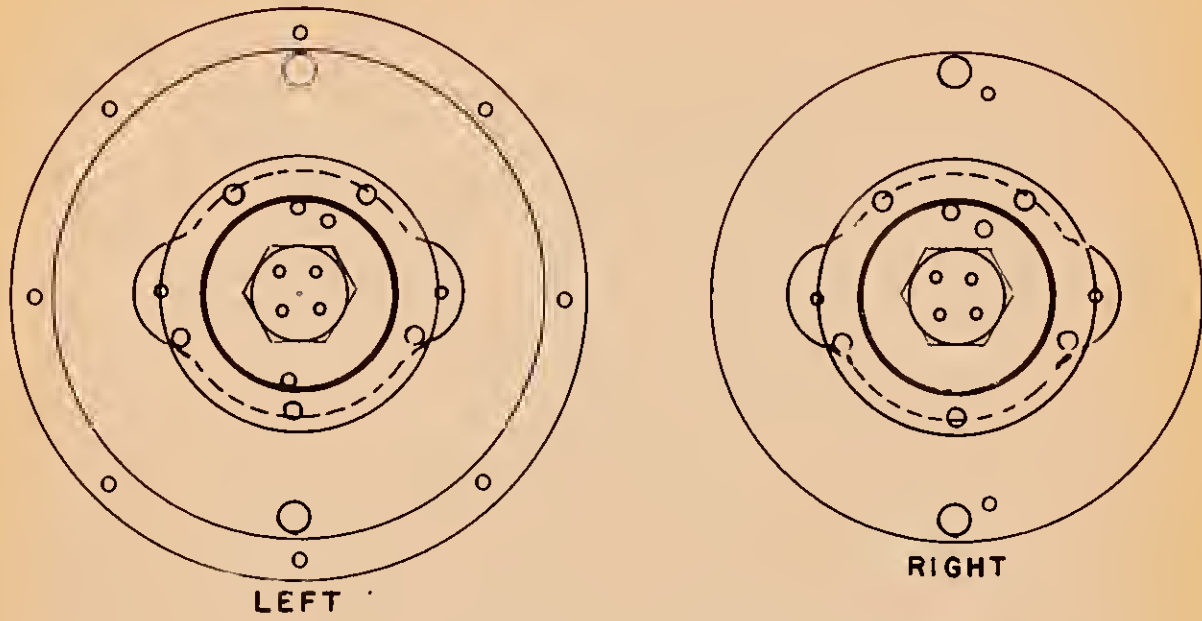

LEFT
RIGHT
END VIEW , ELECTRIC HEATING

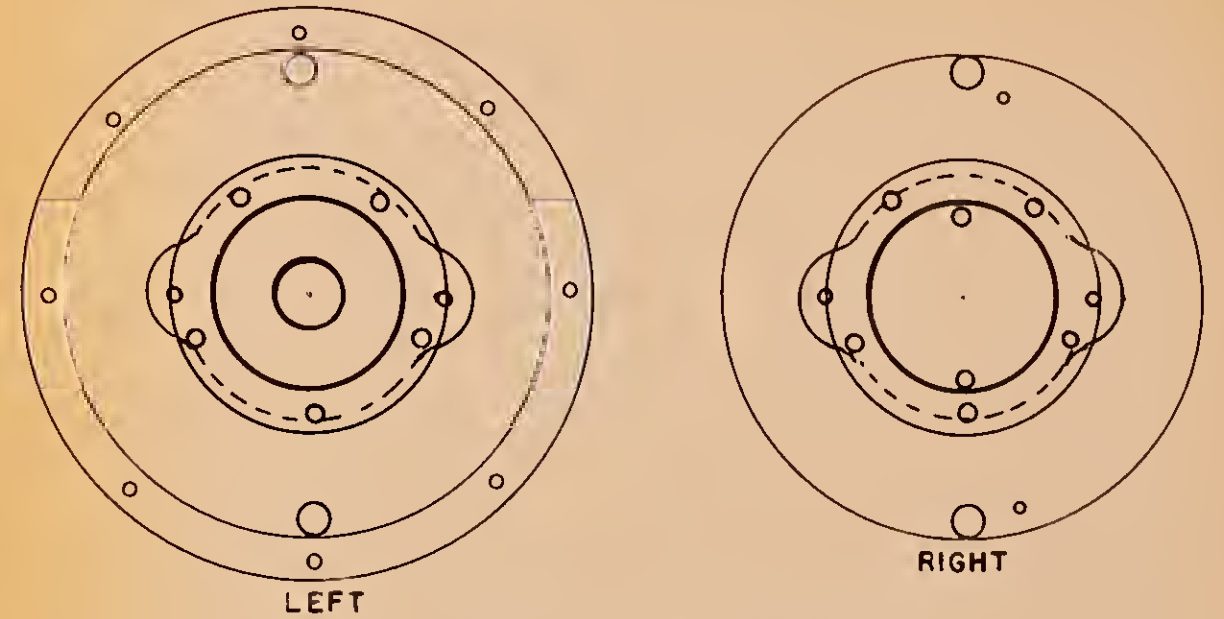

LEFT
RIGHT
END VIEW , STEAM HEATING

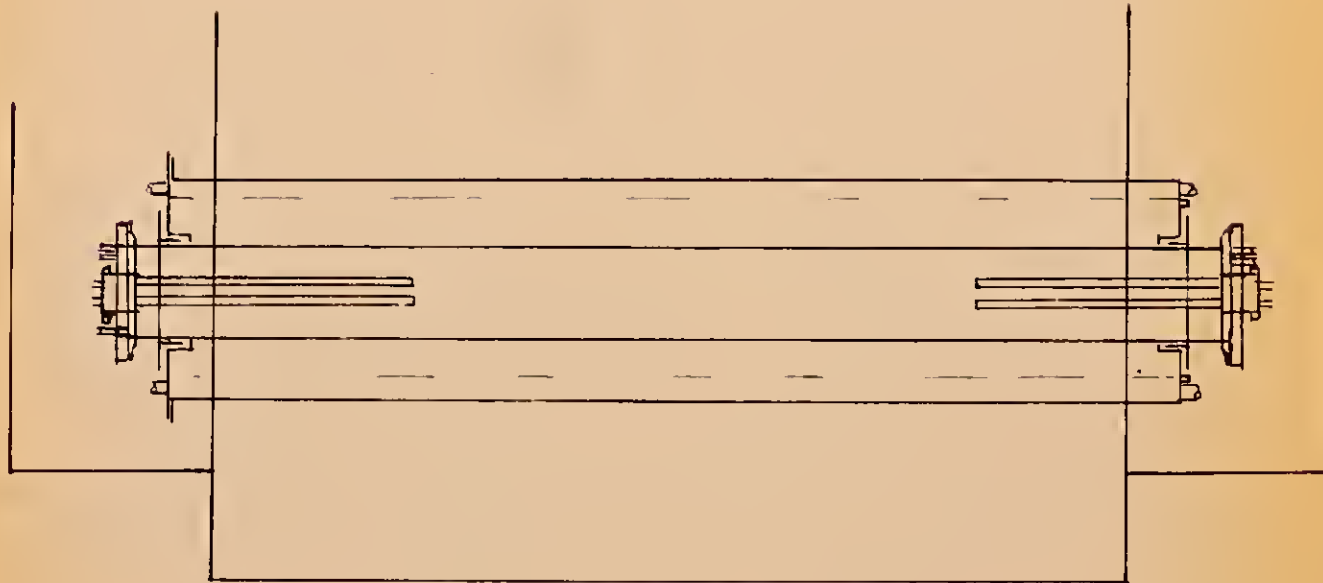

SIDE VIEW , ELECTRIC HEATING

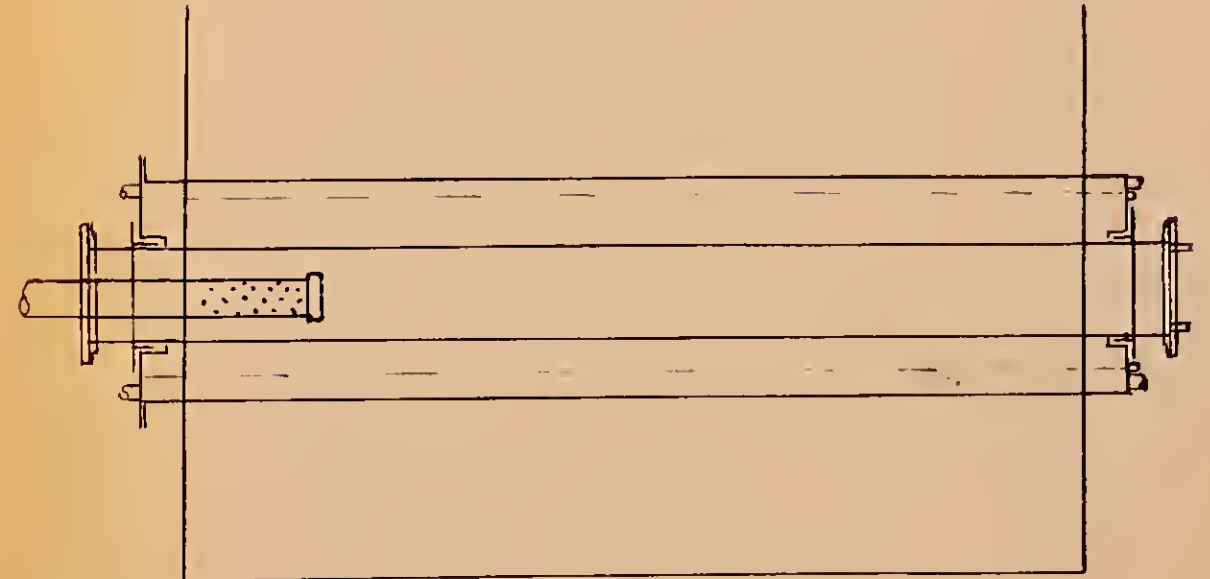

SIDE VIEW , STEAM HEATING

HEAT LOSS OF SYSTEM VS HOURS OF BOILING

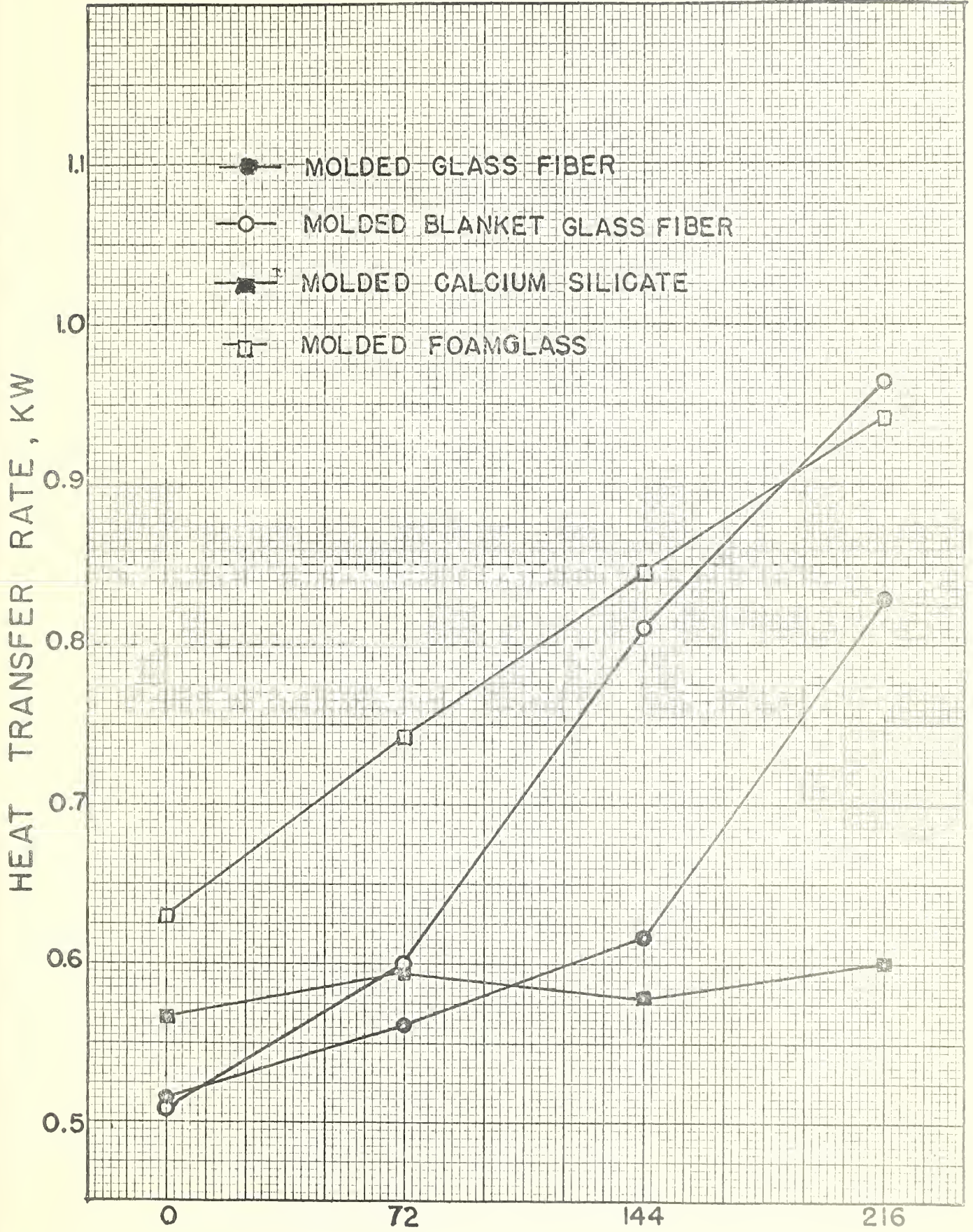

ACCUMULATED BOILING PERIOD , HOURS

FIG 2



Figure 3



Figure 4



Figure 5



Figure 6



Figure 7





Figure 8



Figure 9



Figure 10

U. S. DEPARTMENT OF COMMERCE
Luther H. Hodges, *Secretary*

NATIONAL BUREAU OF STANDARDS
A. V. Astin, *Director*



THE NATIONAL BUREAU OF STANDARDS

The scope of activities of the National Bureau of Standards at its major laboratories in Washington, D.C., and Boulder, Colorado, is suggested in the following listing of the divisions and sections engaged in technical work. In general, each section carries out specialized research, development, and engineering in the field indicated by its title. A brief description of the activities, and of the resultant publications, appears on the inside of the front cover.

WASHINGTON, D.C.

Electricity. Resistance and Reactance. Electrochemistry. Electrical Instruments. Magnetic Measurements. Dielectrics. High Voltage.

Metrology. Photometry and Colorimetry. Refractometry. Photographic Research. Length. Engineering Metrology. Mass and Scale. Volumetry and Densimetry.

Heat. Temperature Physics. Heat Measurements. Cryogenic Physics. Equation of State. Statistical Physics.

Radiation Physics. X-ray. Radioactivity. Radiation Theory. High Energy Radiation. Radiological Equipment. Nucleonic Instrumentation. Neutron Physics.

Analytical and Inorganic Chemistry. Pure Substances. Spectrochemistry. Solution Chemistry. Standard Reference Materials. Applied Analytical Research.

Mechanics. Sound. Pressure and Vacuum. Fluid Mechanics. Engineering Mechanics. Rheology. Combustion Controls.

Organic and Fibrous Materials. Rubber. Textiles. Paper. Leather. Testing and Specifications. Polymer Structure. Plastics. Dental Research.

Metallurgy. Thermal Metallurgy. Chemical Metallurgy. Mechanical Metallurgy. Corrosion. Metal Physics. Electrolysis and Metal Deposition.

Mineral Products. Engineering Ceramics. Glass. Refractories. Enameled Metals. Crystal Growth. Physical Properties. Constitution and Microstructure.

Building Research. Structural Engineering. Fire Research. Mechanical Systems. Organic Building Materials. Codes and Safety Standards. Heat Transfer. Inorganic Building Materials.

Applied Mathematics. Numerical Analysis. Computation. Statistical Engineering. Mathematical Physics. Operations Research.

Data Processing Systems. Components and Techniques. Computer Technology. Measurements Automation. Engineering Applications. Systems Analysis.

Atomic Physics. Spectroscopy. Infrared Spectroscopy. Solid State Physics. Electron Physics. Atomic Physics.

Instrumentation. Engineering Electronics. Electron Devices. Electronic Instrumentation. Mechanical Instruments. Basic Instrumentation.

Physical Chemistry. Thermochemistry. Surface Chemistry. Organic Chemistry. Molecular Spectroscopy. Molecular Kinetics. Mass Spectrometry.

Office of Weights and Measures.

BOULDER, COLO.

Cryogenic Engineering. Cryogenic Equipment. Cryogenic Processes. Properties of Materials. Cryogenic Technical Services.

Ionosphere Research and Propagation. Low Frequency and Very Low Frequency Research. Ionosphere Research. Prediction Services. Sun-Earth Relationships. Field Engineering. Radio Warning Services. Vertical Soundings Research.

Radio Propagation Engineering. Data Reduction Instrumentation. Radio Noise. Tropospheric Measurements. Tropospheric Analysis. Propagation-Terrain Effects. Radio-Meteorology. Lower Atmosphere Physics.

Radio Standards. High Frequency Electrical Standards. Radio Broadcast Service. Radio and Microwave Materials. Atomic Frequency and Time Interval Standards. Electronic Calibration Center. Millimeter-Wave Research. Microwave Circuit Standards.

Radio Systems. Applied Electromagnetic Theory. High Frequency and Very High Frequency Research. Modulation Research. Antenna Research. Navigation Systems.

Upper Atmosphere and Space Physics. Upper Atmosphere and Plasma Physics. Ionosphere and Exosphere Scatter. Airglow and Aurora. Ionospheric Radio Astronomy.

