

317
~~DEP~~
#1300

NATIONAL BUREAU OF STANDARDS REPORT

NBS PROJECT

NBS REPORT

1002-30-10628

June 1, 1960

6267

FIRE ENDURANCE TESTS

of

PULLENAD ASSOCIATES

by

J. V. Ryan

for

U. S. Coast Guard

IMPORTANT NOTICE

NATIONAL BUREAU OF STANDARDS
Intended for use within the
to additional evaluation and
listing of this Report, either
the Office of the Director, or
however, by the Government
to reproduce additional copies.

Approved for public release by the
Director of the National Institute of
Standards and Technology (NIST)
on October 9, 2015.

progress accounting documents
ormally published it is subjected
reproduction, or open-literature
ssion is obtained in writing from
Such permission is not needed,
y prepared if that agency wishes



U. S. DEPARTMENT OF COMMERCE
NATIONAL BUREAU OF STANDARDS

FIRE ENDURANCE TESTS

of

BULKHEAD ASSEMBLIES

by

J. V. Ryan

ABSTRACT

Five bulkhead assemblies were subjected to fire tests. Each specimen was made of 3/4 in. thick marine board with a vertical joint and steel joint member. The members were of the same design in all specimens, but the marine boards differed. The defined limiting temperature rise was reached in from 12.6 to 16.2 min for the various specimens. All served as barriers to the passage of flames throughout the 60-min tests.

1. Introduction

At the request of the U. S. Coast Guard (letter of 22 March 1960), five bulkhead assembly specimens were subjected to fire tests in compliance with Subpart 164.008-3(b) of Specification for Bulkhead Panels for Merchant Vessels.

2. Test Specimens

The specimens were submitted by, and shipped from, Dansk Kternit-Fabrik A/S, Aalborg, Denmark. The specimens and shipping container were received in good condition. The specimens were identified as follows:

1. Navillite 36, type V-22 - both sides plain finish, 3/4 in. thick, proposal 2.
2. Navillite 36, type L-22, both sides plain finish, 3/4 in. thick, proposal 2.
3. Navillite 36, type V55, both sides veneered with Hard Top, 3/4 in. thick, proposal 1.

4. Navilite 42, type K-22, both sides plain finish, 3/4 in. thick, proposal 1.
5. Navilite 48, type K-22, both sides plain finish, 3/4 in. thick, proposal 2.

The proposal numbers refer to alternate details at the top of the specimen. These and other details are shown in Figure 1, at the end of this report. The specimens were received assembled; therefore, the details are based primarily on examination after test.

In general appearance, each specimen consisted of two panels of marine board with a vertical joint member, all mounted in a frame. The joint member and frame were of steel; and were assembled to allow for movement due to thermal expansion. The marine boards were moderately hard, white, and appeared to be of cement-asbestos. Those for specimen 3 had a veneer of very hard smooth material on each face.

3. Test Method

The specimens were mounted in the three openings of a test frame modified to permit the simultaneous fire exposure of three bulkheads in the wall test furnace. Bulkheads 1, 2, and 3 were tested together in the first test (414); 4, 5, and a filler were tested together in the second test (415). Care was taken that each specimen was restrained against vertical movement, so that the only relief for thermal expansion was that provided for in the design and fabrication of the specimen. The peripheral joints between the specimens and the test frame were sealed with a fillet of plaster on the side to be exposed to fire. This plaster fillet covered all the metal members except that along the prescribed vertical joint between the panels of Navilite boards. Eight thermocouples were placed on the unexposed surface of each specimen, distributed as shown in the figures. The junction and several inches of the wires of each thermocouple were covered by a 6- by 6- by 0.4-in. felted asbestos pad. Twelve thermocouples, encased in porcelain insulators and iron pipes, were distributed within the furnace chamber. The furnace fires were controlled to produce average furnace temperatures as close as feasible to those of the standard time-temperature curve of ASTM E119, which include: 1000°F at 5 min, 1300° at 10 min, 1550°F at 30 min, 1700°F at 1 hr.

4. Results

Both tests were witnessed by Mr. Paul Gibson, USCG, Washington, D. C. and personnel of the National Bureau of Standards, Fire Protection Section.

4.1 Test 414

The test of specimens 1, 2, and 3 was conducted on April 7, 1960. The hard veneer exposed surface of specimen 3 (Navilite 36, type V55) spalled at 2 min, leaving about half the original material in scattered pieces over the exposed area. This was followed by brief flaming over the spalled areas. Smoke came through the joint of specimen 3 at 21 min. The test was stopped at 1 hr. There had been no cracking of the unexposed surface of any of the specimens. The condition of the specimens after test is shown in Figures 2 and 3.

The time at which the limiting 250°F rise was reached at the highest reading thermocouple on the unexposed surface of the marine board of each specimen, as well as the maximum deflection at the center of each, is given in the following table.

	<u>Specimen</u>		
	1	2	3
250°F rise, time, min.	12.6	13.1	16.2
max deflection, in.	1.25	0.5	1.25

The fire exposure severity was 101.5 per cent. No flames passed through any of the three specimens. Additional temperature data are presented in Figure 1. The temperatures from the joints were averaged separately from those on the Navilite boards.

4.2 Test 415

The test of specimens 4 and 5 was conducted April 14, 1960. Except for deflection due to bowing of the steel members, discoloration of the paint on the latter, and slight smoking from the joints over a 4-min period, there were no observable changes during the 1-hr test. There was no cracking of the unexposed surface of either specimen. The conditions of the specimens after test were essentially the same as those of specimens 1 and 2, shown in Figures 2 and 3.

The time at which the limiting 250°F rise was reached at the highest reading thermocouple on the unexposed surface of the marine board of each specimen, as well as the maximum deflection at the center of each, is given in the following table

	<u>Specimen</u>	
	4	5
250°F rise, time, min.	14.3	12.6
Max deflection, in.	1.75	1.0

The fire exposure severity was 98.7 per cent. No flames passed through either specimen. Additional temperature data are presented in Figure 1. The temperatures from the joints were averaged separately from those on the Navilite boards.

5. Summary

The results of the two tests, involving five bulkhead specimens, indicated that each remained an effective barrier to the passage of flames throughout the 1 hr test durations. The limiting temperature rise of 250°F at any thermocouple, except those on the joint members, was reached in from 12.6 to 16.2 min, for the various specimens.

Since the metal members across the tops of the specimens were covered with plaster, in order to seal the joints between specimens and furnace frame, it is not practical to attempt comparisons between the alternate details represented by the two proposals. However, even if the plaster seal had been omitted, comparison would not be practical because the behavior near the edges of fire test specimens is ignored as a matter of the standard test method.

Figure 1. Time-temperature curves and construction details

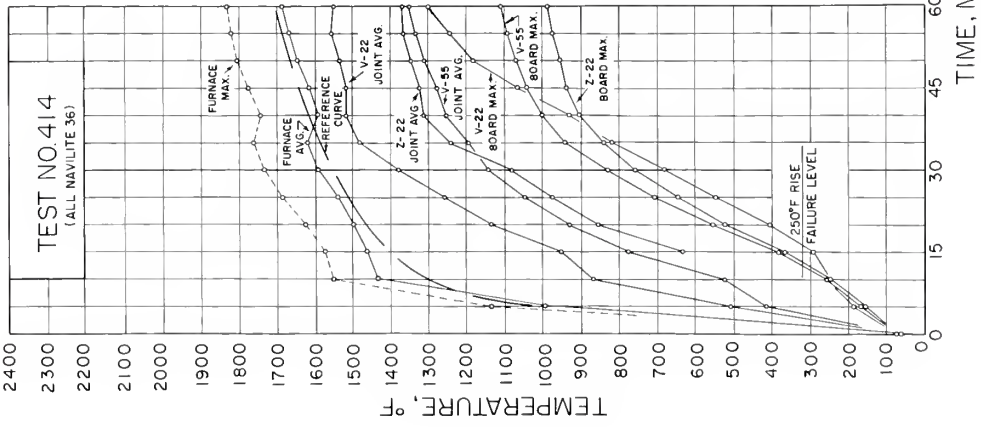
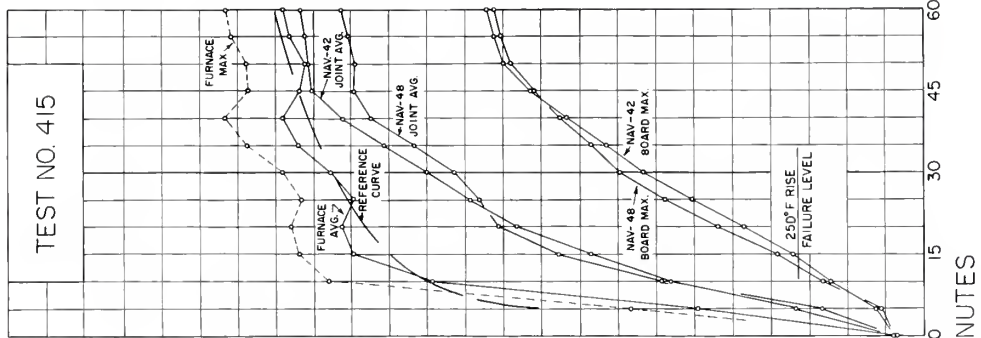
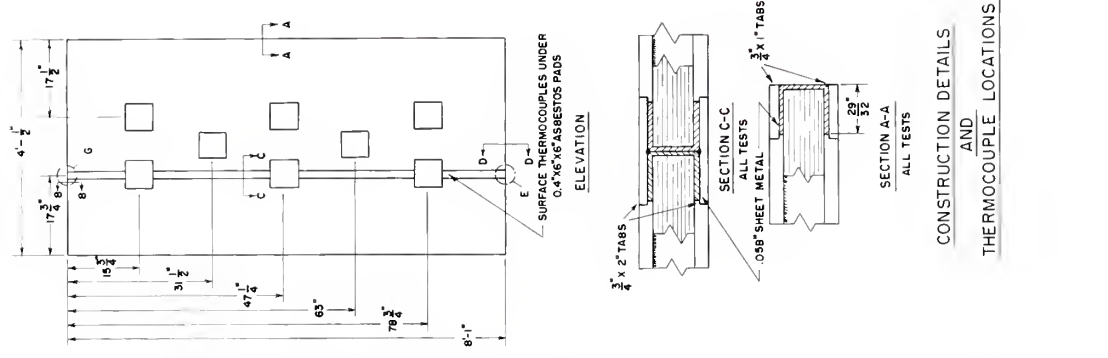
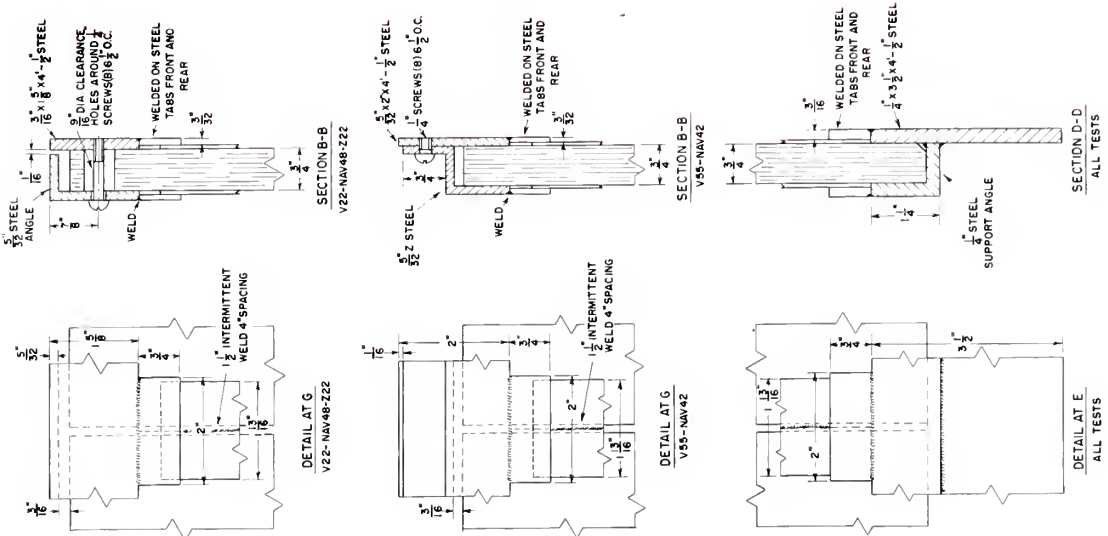

CONSTRUCTION DETAILS
AND
THERMOCOUPLE LOCATIONS

28973 |

Figure 2. One posed surface at end of test 414;
specimens 1, 2, and 3 from left to right.

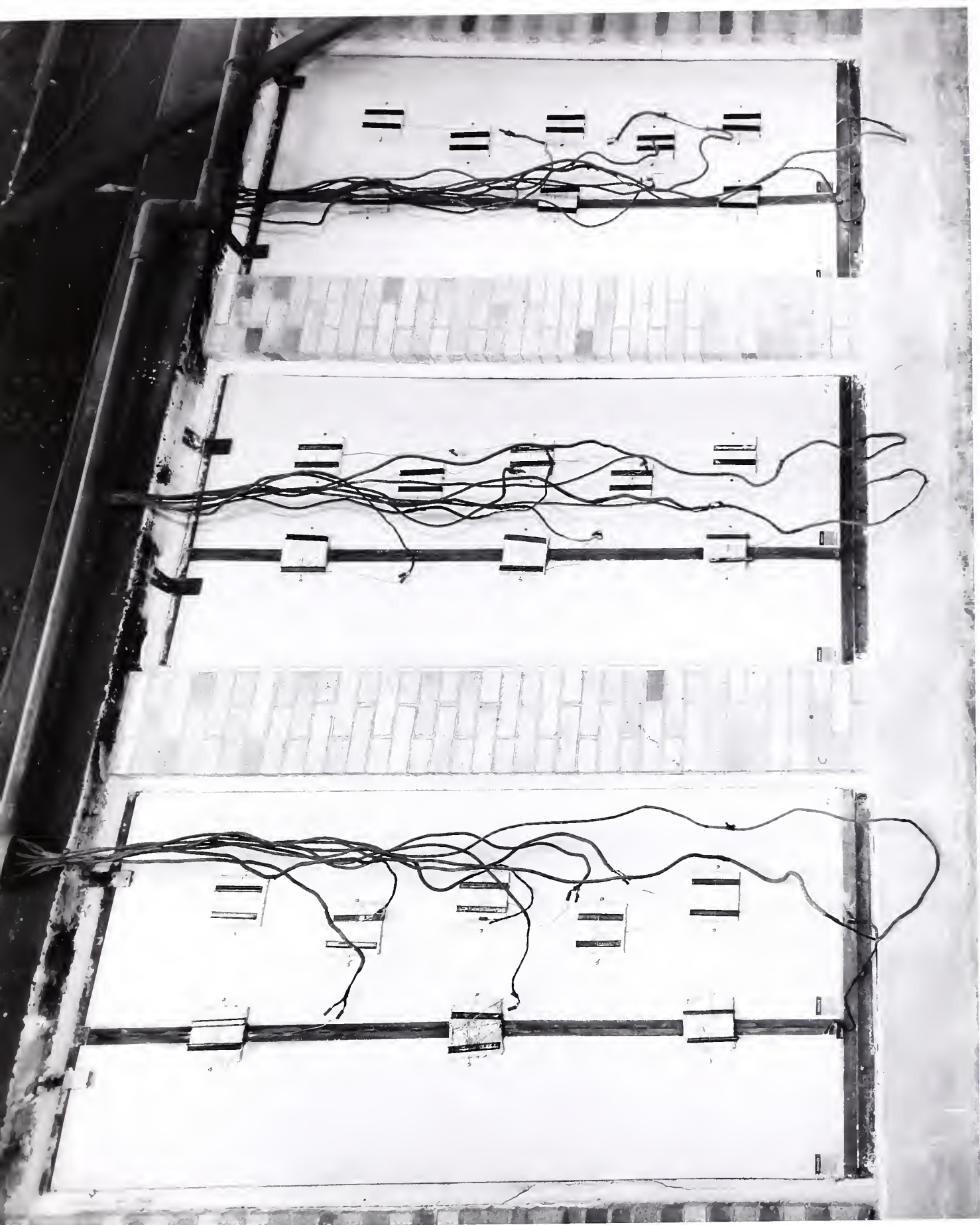

28868 1

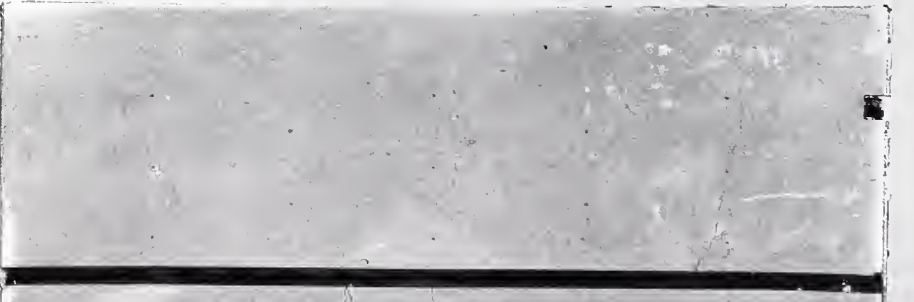
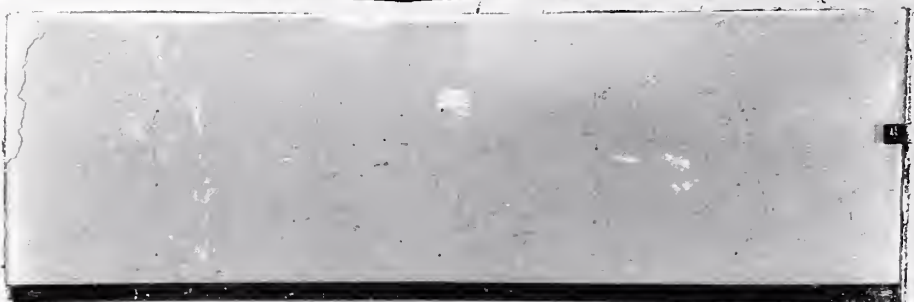

Figure 3. Exposed surface after test 414; specimens 1, 2, and 3 from right to left. The surface of specimen 3 spalled early in the test. The cracks in specimens 1 and 2 developed during cooling and did not extend through to the unexposed surface.



28868 2



Made with

CUTLESS / WaterShield.
Paper

WaterShield® and Cutless® Paper are Registered
Trademarks of International Paper. Trademark Company,
used under license with International Paper.

No. 11951



www.sfi.org/americ

Made in USA

GET ORGANIZED AT SMEAD.COM

