

NATIONAL BUREAU OF STANDARDS REPORT

5240

PERFORMANCE TESTS OF AN ELECTRO-AIR
"HIGH CAPACITY" ELECTRONIC AIR CLEANER

by

Thomas W. Watson
Henry E. Robinson

Report to
General Services Administration
Public Buildings Service
Washington 25, D. C.



U. S. DEPARTMENT OF COMMERCE
NATIONAL BUREAU OF STANDARDS

U. S. DEPARTMENT OF COMMERCE

Sinclair Weeks, *Secretary*

NATIONAL BUREAU OF STANDARDS

A. V. Astin, *Director*



THE NATIONAL BUREAU OF STANDARDS

The scope of activities of the National Bureau of Standards at its headquarters in Washington, D. C., and its major field laboratories in Boulder, Colorado, is suggested in the following listing of the divisions and sections engaged in technical work. In general, each section carries out specialized research, development, and engineering in the field indicated by its title. A brief description of the activities, and of the resultant reports and publications, appears on the inside back cover of this report.

WASHINGTON, D. C.

Electricity and Electronics. Resistance and Reactance. Electron Tubes. Electrical Instruments. Magnetic Measurements. Dielectrics. Engineering Electronics. Electronic Instrumentation. Electrochemistry.

Optics and Metrology. Photometry and Colorimetry. Optical Instruments. Photographic Technology. Length. Engineering Metrology.

Heat and Power. Temperature Physics. Thermodynamics. Cryogenic Physics. Rheology and Lubrication. Engine Fuels.

Atomic and Radiation Physics. Spectroscopy. Radiometry. Mass Spectrometry. Solid State Physics. Electron Physics. Atomic Physics. Nuclear Physics. Radioactivity. X-rays. Betatron. Nucleonic Instrumentation. Radiological Equipment. AEC Radiation Instruments.

Chemistry. Organic Coatings. Surface Chemistry. Organic Chemistry. Analytical Chemistry. Inorganic Chemistry. Electrodeposition. Gas Chemistry. Physical Chemistry. Thermochemistry. Spectrochemistry. Pure Substances.

Mechanics. Sound. Mechanical Instruments. Fluid Mechanics. Engineering Mechanics. Mass and Scale. Capacity, Density, and Fluid Meters. Combustion Controls.

Organic and Fibrous Materials. Rubber. Textiles. Paper. Leather. Testing and Specifications. Polymer Structure. Organic Plastics. Dental Research.

Metallurgy. Thermal Metallurgy. Chemical Metallurgy. Mechanical Metallurgy. Corrosion. Metals Physics.

Mineral Products. Engineering Ceramics. Glass. Refractories. Enameled Metals. Concreting Materials. Constitution and Microstructure.

Building Technology. Structural Engineering. Fire Protection. Heating and Air Conditioning. Floor, Roof, and Wall Coverings. Codes and Specifications.

Applied Mathematics. Numerical Analysis. Computation. Statistical Engineering. Mathematical Physics.

Data Processing Systems. SEAC Engineering Group. Components and Techniques. Digital Circuitry. Digital Systems. Analogue Systems. Application Engineering.

• Office of Basic Instrumentation

• Office of Weights and Measures

BOULDER, COLORADO

Cryogenic Engineering. Cryogenic Equipment. Cryogenic Processes. Properties of Materials. Gas Liquefaction.

Radio Propagation Physics. Upper Atmosphere Research. Ionospheric Research. Regular Propagation Services. Sun-Earth Relationships.

Radio Propagation Engineering. Data Reduction Instrumentation. Modulation Systems. Navigation Systems. Radio Noise. Tropospheric Measurements. Tropospheric Analysis. Radio Systems Application Engineering.

Radio Standards. Radio Frequencies. Microwave Frequencies. High Frequency Electrical Standards. Radio Broadcast Service. High Frequency Impedance Standards. Calibration Center. Microwave Physics. Microwave Circuit Standards.

62-21647

NATIONAL BUREAU OF STANDARDS REPORT

NBS PROJECT

NBS REPORT

1000-30-4830

April 18, 1957

5240

PERFORMANCE TESTS OF AN ELECTRO-AIR
"HIGH CAPACITY" ELECTRONIC AIR CLEANER

by

Thomas W. Watson
Henry E. Robinson
Heat Transfer Section
Building Technology Division

to

General Services Administration
Public Buildings Service
Washington 25, D. C.

IMPORTANT NOTICE

NATIONAL BUREAU OF STANDARDS REPORTS are intended for use within the Government. For additional evaluation and revision, listing of this Report, either in whole or in part, the Office of the Director, National Bureau of Standards, however, by the Government agency, to reproduce additional copies for

Approved for public release by the
Director of the National Institute of
Standards and Technology (NIST)
on October 9, 2015.

less accounting documents
ly published it is subjected
roduction, or open-literature
is obtained in writing from
h permission is not needed,
ared if that agency wishes



U. S. DEPARTMENT OF COMMERCE
NATIONAL BUREAU OF STANDARDS

PERFORMANCE TESTS OF AN ELECTRO-AIR MODEL 20-C
"HIGH CAPACITY" ELECTRONIC AIR CLEANER

by

Thomas W. Watson and Henry E. Robinson

1. INTRODUCTION

At the request of the Public Buildings Service, General Services Administration, the performance characteristics of electrostatic air cleaners were determined to provide information to assist in the preparation of new air filter specifications.

The test results presented herein were obtained on a specimen electrostatic filter unit submitted by its manufacturer at the request of the Public Buildings Service and included determinations of dust-arresting efficiency with two aerosols (atmospheric air and Cottrell precipitate), pressure drop, specific dirt load, and cleanability of the specimen.

2. DESCRIPTION OF THE FILTER SPECIMEN

The cleaner was manufactured by the Electro-Air Cleaner Company, Pittsburgh 33, Pennsylvania, and was of the electrostatic type. It was identified by the manufacturer as an "Electro-Air High Capacity Electronic Air Cleaner Model 20-C," with one cell rated at 1450 cfm. The power pack nameplate data furnished by the manufacturer were as follows:

Type B

Input: 60 cycles, 115 volts, 2 amp primary (maximum)

Output: 8,200 volts D. C.

The test unit had a housing with transverse outside dimensions $24 \frac{1}{8}$ X $19 \frac{5}{8}$ inches and was 20 inches long. The upstream and downstream faces had special flanges 32 inches square overlapping those of the duct of the test apparatus by one inch. The downstream face was adapted to receive a nominal 24 X $19 \frac{1}{2}$ X 2-inch afterfilter, which for this unit was a $23 \frac{7}{8}$ X $19 \frac{7}{16}$ X $1 \frac{7}{8}$ -inch viscid impingement type air filter manufactured by the Research Products Corporation of Madison, Wisconsin. The afterfilter had a net face area of 2.85 square feet.

The filter cell of the unit was 23 7/8 inches in height, 19 1/2 inches in width, and 17 inches in length, and contained 57 aluminum plates (23 X 10 3/4 inches in dimension) spaced 5/16 inch apart on centers, presenting a total surface area of approximately 196 square feet. The gross inlet area of the ionizer assembly was 2.53 square feet and the cell transverse area was 3.05 square feet.

The manufacturer furnished an adhesive, designated as "Carbide and Carbon Chemicals Company PN-1083 cold water adhesive," with which the collector plates were oiled by spraying them from the upstream face. The afterfilter was oiled in preparation for the test by spraying the media from the upstream and downstream sides with the same adhesive.

The power pack, connected to a 115-volt 60-cycle supply, was adjusted by the manufacturers' representative to recommended settings prior to the tests; the ionizer and plate voltages that resulted were measured by means of an accurate electrostatic voltmeter.

3. TEST METHOD AND PROCEDURE

Efficiency determinations were made by the NBS "Dust-Stop Method" using the following aerosols: (a) outdoor air drawn through the laboratory without addition of other dust or contaminant and (b) Cottrell precipitate. The test method is described in the paper, "A test Method for Air Filters," by R. S. Dill (ASHVE Transactions, Vol. 44, p. 379, 1938). The test duct and arrangement are shown in Figure 1. A baffle made of two 3-inch wide slats was located in the duct about 3 1/2 feet downstream of the test assembly to intermix the air discharged from it.

For these tests, the unit was installed in the test duct and carefully sealed to prevent inleakage of air. The desired rate of air flow through the air cleaner was established and samples of air were drawn from the center points of the test duct one foot upstream and eight feet downstream of the air cleaner assembly at equal rates and passed through known areas of Whatman No. 41 filter paper. For the atmospheric air tests, the samples were drawn at equal rates through equal areas of filter paper (3/4-inch diameter spots). The downstream sample was drawn continuously during the test; the upstream sample was drawn intermittently in a number of one-minute periods uniformly distributed over the duration of the test, aggregating one-tenth of the downstream sampling period. Under these conditions an efficiency of 90 percent would be indicated if the upstream and downstream dust-spots on the filter papers had the

same opacity, as indicated by the change in the light transmissions of the dust-spot areas before and after the sample was drawn, which were determined by means of a photometer using transmitted light. The filter papers used in the upstream and downstream positions were selected to have the same light transmission readings when clean. If the opacities of the dust-spots differed, the efficiency was calculated by means of the formula

$$\text{Efficiency, percent} = 100 \left[1 - \frac{t_1}{t_2} \cdot \frac{O_2}{O_1} \right] = 100 - 10 \left(\frac{O_2}{O_1} \right)$$

where O_1 and O_2 were the opacities of the dust-spots upstream and downstream, respectively, and t_1 and t_2 were the aggregate times during which the upstream and downstream samples, respectively, were drawn.

For the efficiency tests with Cottrell precipitate as the aerosol, the samples upstream and downstream were drawn at equal rates and for equal times but unequal dust-spot areas were used to obtain opacities that were approximately equal. If the opacities of the dust-spots differed, the value of the efficiency was calculated by means of the formula above, with the ratio A_2/A_1 substituted for the ratio t_1/t_2 , where A_2 and A_1 were the areas of the dust-spots downstream and upstream, respectively.

The following procedure was employed in these tests. After the clean and oiled unit had been installed in the test duct, and all discoverable air leaks into its housing had been sealed, its input and output voltages were adjusted to recommended values by a representative of the manufacturer: (input 115 volts; ionizer and plates 8.2 kv). Two determinations of the efficiency of the clean unit were made at the rated velocity, using as the aerosol outdoor air drawn into the test duct through a nearby open window. A determination of efficiency with the unit not energized was also made. Following these, single determinations were made, using outdoor air, at air flows 20 percent greater, and 20 percent less than the rated air flow.

Following these, two efficiency determinations were made at the rated air flow, using as an aerosol outdoor air in which was dispersed Cottrell precipitate at a concentration of one gram per thousand cubic feet of air. When these had been obtained, the process was begun of loading the unit with a mixture of 4 percent cotton lint and 96 percent Cottrell precipitate, by weight, separately dispersed into the air stream. The lint used for this purpose was No. 7 cotton linters

previously ground in a Wiley mill with a four-millimeter screen; the lint was dispersed into the air stream through an aspirator operating at approximately 35 psi inlet air pressure. At suitable periods, as loading progressed, the efficiency of the unit was determined using 100 percent Cottrell precipitate in outdoor air. In these tests, and during the loading process, the rate of feed of the dispersant was one gram per thousand cubic feet of air. The pressure drop and the ionizer and plate voltages of the unit were recorded at intervals during the tests. The dirt-loading process was continued until 968 grams of the lint and Cottrell precipitate mixture had been fed (i.e., 2/3 gram per cfm of unit rating).

At suitable periods as the dirt-loading process progressed, strips of transparent cellulose adhesive tape (3/4-inch wide) were stretched vertically across the test duct near its axis, with the adhesive side facing upstream. Tapes were located at two positions, (1) 12 inches upstream and (2) 15 inches downstream of the test unit. The adhesive surface of such a tape captured a sample of the particulate matter in the air flowing past it, and after suitable times of exposure to the aerosol, scrutiny of the tapes by eye and with a microscope afforded considerable information as to the vertical distribution, the nature, number, and size of the particles caught at the various stations.

The filter cell was removed from the test unit and cleaned by means of a stream of cold water from a high pressure hose nozzle, directed at and into the cell plates from both ends of the unit. The cleanability of the afterfilter was determined separately, by the same means.

4. TEST RESULTS

A summary of the test data giving efficiencies in percent with the two aerosols and the pressure drop of the complete unit, including the afterfilter, in inch W. G., at several rates of air flow, is given in Table 1. A summary of the test data obtained in the dirt-loading test, conducted at 1450 cfm is given in Table 2.

Throughout the tests with atmospheric air, electrical sparking or flashing in the unit audible to the ear occurred, on the average, about seven times per hour. However, during the Cottrell and lint loading test, electrical sparking or flashing occurred intermittently, the frequency increasing from about 15 to 20 times per minute at the start to about 30 to 35 times per minute at the end of the loading test.

5. SUMMARY

A. Performance.

The efficiency of the air cleaner in arresting the particulate matter existent in atmospheric air drawn through the unit varied considerably with the air flow at which it was operated, as shown in Table 1. At the rated air flow (1450 cfm), the average efficiency on atmospheric air was 91.2 percent. The efficiencies are reported to three significant figures obtained from the test data. In reporting thus, however, it is considered desirable to point out that an uncertainty on the order of one or two percent is possible in determining efficiencies.

As recorded in Table 2, the ionizer and plate voltages remained substantially constant throughout the dirt-loading test. The efficiency of the unit on Cottrell precipitate as the aerosol remained at a high level, never falling below 98.4 percent and ending with a value of 99.3 percent, slightly greater than at the start of the dirt-loading test. An efficiency determination made with atmospheric air at the end of the dirt-loading test indicated that the efficiency of the unit on this aerosol was higher when it was dirt laden than when it was clean.

The greater part of the pressure drop through the complete unit was due to the resistance of the afterfilter. It is noted in Table 2 that in the dirt-loading test, the pressure drop of the complete unit increased by 0.253-inch W. G., for a total load of 968 grams. The rise was due chiefly to an increase in the pressure drop of the afterfilter, as a result of an accumulation of cotton lint and of comparatively large particles of Cottrell precipitate on its media.

B. Cleanability.

The filter was subjected to the cleaning process described under Test Method and Procedure. No difficulty was experienced in thoroughly cleaning the ionizer and collector sections of the unit, using moderate care. The afterfilter was also satisfactorily cleaned using the same procedure.

C. General.

On completion of the dirt-loading test, the unit was removed from the test duct and examined. The ionizer assembly and bars, and the insulators were generally coated with a

moderate layer of dust and lint. Dirt deposits were heaviest on the upstream edges and first three or four inches of the collector plates, the thickness of the deposits being up to about 1/32 inch. The heaviest deposits were observed on the leading edges of the negative plates. A continuous, but thinner, layer of dirt was deposited over the remaining area of the collector plates, extending to the aft edges. There was no observable bridging of lint between any of the collector plates at the conclusion of the tests.

The upstream face of the afterfilter revealed considerable deposits of lint, somewhat concentrated in two horizontal strips, each about eight inches wide. The afterfilter was approximately uniformly darkened by a dust deposit on its upstream face.

The dirt (dust) deposits on the electrostatic unit and on the afterfilter appeared to be well saturated with oil. After the unit had been removed from the test duct, the duct section downstream of the unit was carefully swept out with a fine brush. The amount of material obtained from this sweeping was 0.8 gram.

Cellophane tapes, stretched across the test duct downstream of the filter unit with the adhesive side facing upstream, indicated upon visual and microscopic examination after exposure to the air stream throughout the dirt-loading test, that a few particles up to about 200 microns in size had passed through the unit during the dirt-loading tests. Particles smaller than five microns were observed in quantity by microscopic examination of the downstream filter papers and tapes obtained in tests with both aerosols. A considerable number of lint fibers was also observed on the downstream tapes that were obtained during the dirt-loading tests.

Comparison of the numbers of particles on the upstream and downstream tapes indicated, in an obvious way, a high order of efficiency for the unit in arresting Cottrell precipitate, as is also indicated by the discoloration test results presented in Table 2. The latter results show a considerably higher efficiency for the unit when Cottrell precipitate was being received in the air stream than when the aerosol was outdoor air. The overall efficiency of the unit on particles of the sizes found in Cottrell precipitate appears therefore to be better than on the finer particles in outdoor air. Nevertheless, the downstream tapes, and the deposits on the afterfilter, show that a few quite large particles of dust escaped beyond the electrostatic unit. Whether the large particles were passed through the unit because they were not arrested at all, or were caught and later dislodged from the collector plates by electrical sparking, is not known from these tests.

As the downstream tapes indicate, a few large particles of dust and lint passed unarrested through the afterfilter. Assuming that one of the functions of the afterfilter is to arrest as much as possible of the material escaping the electrostatic unit, the arrestance characteristics of the afterfilter are of major importance in determining the presence or absence, in the air leaving the complete unit, of such particulate matter.

Table 1

<u>Air Flow</u> cfm	<u>Inlet Aerosol*</u>	<u>Ionizer and Plate Voltage</u> kv	<u>Pressure Drop</u> in. W.G.	<u>Duration of Test</u> min.	<u>Efficiency</u> percent
1450	A	0	0.247	20	6.6**
1450	A	8.2	.247	180	90.6
1450	A	8.2	.246	180	91.7
1160	A	8.2	.158	180	94.5
1740	A	8.2	.362	180	85.1
1450	C	8.2	.247	10	98.2
1450	C	8.2	.247	10	98.6

*A = Particulate matter in atmospheric air at NBS.

C = Cottrell precipitate in atmospheric air (1 gram/1000 cf).

**Since unit was not energized, the efficiency was chiefly that of the afterfilter.

Table 2

<u>Air Flow</u> cfm	<u>Dirt Load*</u> grams	<u>Ionizer and Plate Voltage</u> kv	<u>Primary Current</u> amps	<u>Pressure Drop</u> in. W.G.	<u>Efficiency**</u> percent
1450	29	8.2	0.5	0.249	98.4(avg.)
	217	8.0	.5	.270	99.0
	470	8.1	.5	.317	99.3
	742	8.3	.5	.398	98.9
	968	8.2	.5	.502	99.3
	968	8.2	.5	.502	92.3(a)

* Average mixture: 4.0% lint, 96% Cottrell precipitate by weight.

** Efficiency determined with 100% Cottrell precipitate.

(a) Efficiency determined with aerosol "A" as in Table 1, with the unit dirty.

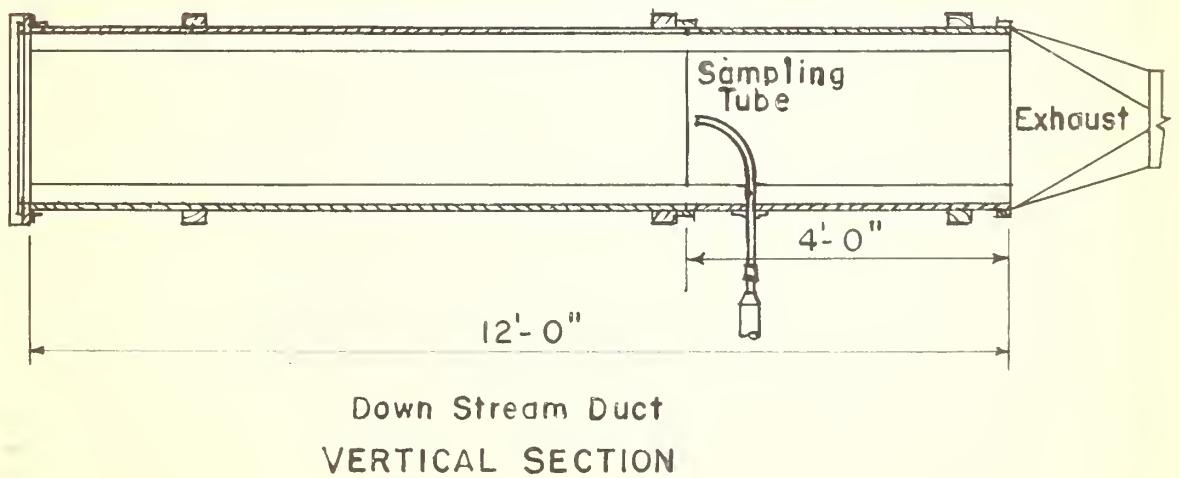
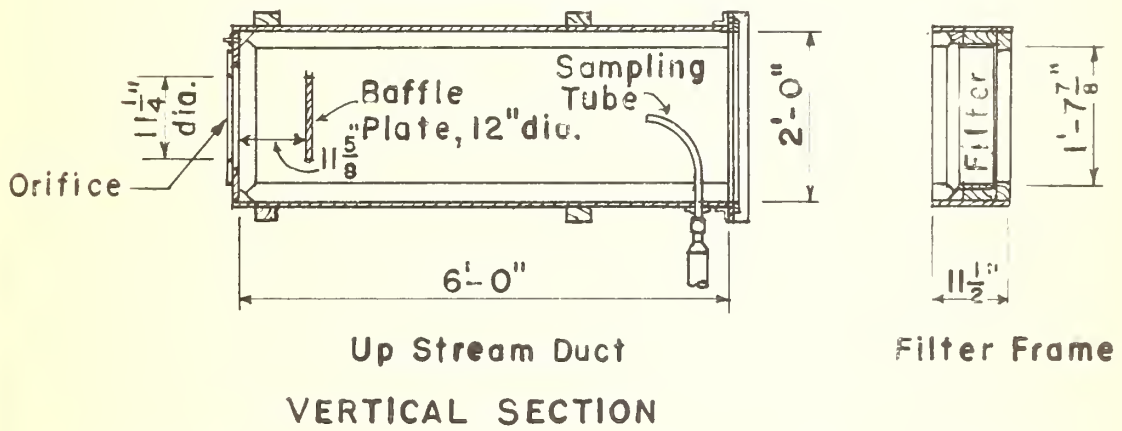
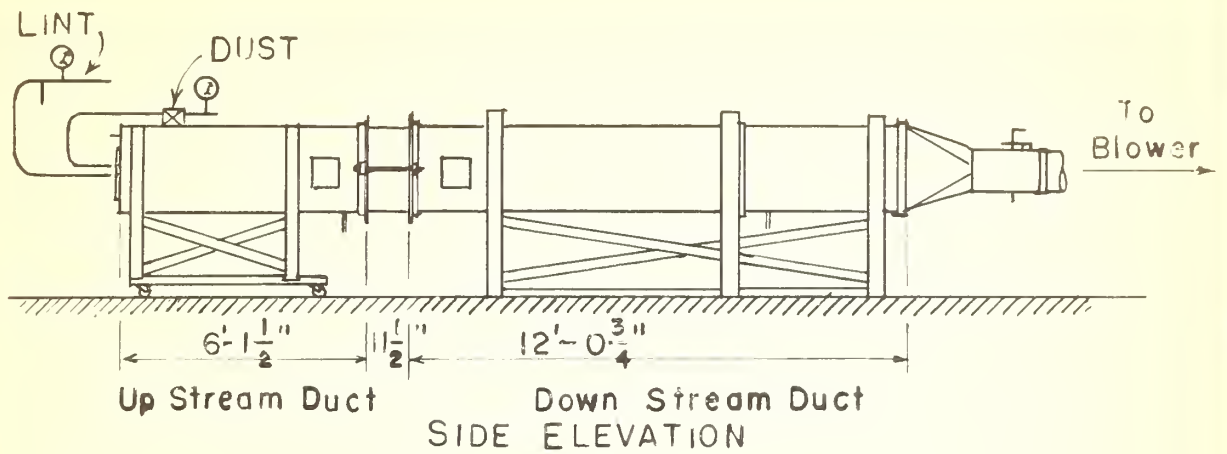

Air Filter Test Apparatus



Figure 1

THE NATIONAL BUREAU OF STANDARDS

Functions and Activities

The functions of the National Bureau of Standards are set forth in the Act of Congress, March 3, 1901, as amended by Congress in Public Law 619, 1950. These include the development and maintenance of the national standards of measurement and the provision of means and methods for making measurements consistent with these standards; the determination of physical constants and properties of materials; the development of methods and instruments for testing materials, devices, and structures; advisory services to Government Agencies on scientific and technical problems; invention and development of devices to serve special needs of the Government; and the development of standard practices, codes, and specifications. The work includes basic and applied research, development, engineering, instrumentation, testing, evaluation, calibration services, and various consultation and information services. A major portion of the Bureau's work is performed for other Government Agencies, particularly the Department of Defense and the Atomic Energy Commission. The scope of activities is suggested by the listing of divisions and sections on the inside of the front cover.

Reports and Publications

The results of the Bureau's work take the form of either actual equipment and devices or published papers and reports. Reports are issued to the sponsoring agency of a particular project or program. Published papers appear either in the Bureau's own series of publications or in the journals of professional and scientific societies. The Bureau itself publishes three monthly periodicals, available from the Government Printing Office: *The Journal of Research*, which presents complete papers reporting technical investigations; the *Technical News Bulletin*, which presents summary and preliminary reports on work in progress; and *Basic Radio Propagation Predictions*, which provides data for determining the best frequencies to use for radio communications throughout the world. There are also five series of nonperiodical publications: *The Applied Mathematics Series*, *Circulars*, *Handbooks*, *Building Materials and Structures Reports*, and *Miscellaneous Publications*.

Information on the Bureau's publications can be found in *NBS Circular 460, Publications of the National Bureau of Standards* (\$1.25) and its *Supplement* (\$0.75), available from the Superintendent of Documents, Government Printing Office, Washington 25, D. C.

Inquiries regarding the Bureau's reports should be addressed to the Office of Technical Information, National Bureau of Standards, Washington 25, D. C.

