

9

2010
#520

NATIONAL BUREAU OF STANDARDS REPORT

3229

PRELIMINARY EXPERIMENTS
WITH A
RADIANT PANEL FLAME-SPREAD TEST METHOD

by

A. F. Robertson, R. Kreisler and D. Gross



U. S. DEPARTMENT OF COMMERCE
NATIONAL BUREAU OF STANDARDS

U. S. DEPARTMENT OF COMMERCE

Sinclair Weeks, *Secretary*

NATIONAL BUREAU OF STANDARDS

A. V. Astin, *Director*



THE NATIONAL BUREAU OF STANDARDS

The scope of activities of the National Bureau of Standards is suggested in the following listing of the divisions and sections engaged in technical work. In general, each section is engaged in specialized research, development, and engineering in the field indicated by its title. A brief description of the activities, and of the resultant reports and publications, appears on the inside of the back cover of this report.

Electricity. Resistance and Reactance Measurements. Electrical Instruments. Magnetic Measurements. Electrochemistry.

Optics and Metrology. Photometry and Colorimetry. Optical Instruments. Photographic Technology. Length. Engineering Metrology.

Heat and Power. Temperature Measurements. Thermodynamics. Cryogenic Physics. Engines and Lubrication. Engine Fuels. Cryogenic Engineering.

Atomic and Radiation Physics. Spectroscopy. Radiometry. Mass Spectrometry. Solid State Physics. Electron Physics. Atomic Physics. Neutron Measurements. Infrared Spectroscopy. Nuclear Physics. Radioactivity. X-Ray. Betatron. Nucleonic Instrumentation. Radiological Equipment. Atomic Energy Commission Radiation Instruments Branch.

Chemistry. Organic Coatings. Surface Chemistry. Organic Chemistry. Analytical Chemistry. Inorganic Chemistry. Electrodeposition. Gas Chemistry. Physical Chemistry. Thermochemistry. Spectrochemistry. Pure Substances.

Mechanics. Sound. Mechanical Instruments. Fluid Mechanics. Engineering Mechanics. Mass and Scale. Capacity, Density, and Fluid Meters. Combustion Control.

Organic and Fibrous Materials. Rubber. Textiles. Paper. Leather. Testing and Specifications. Polymer Structure. Organic Plastics. Dental Research.

Metallurgy. Thermal Metallurgy. Chemical Metallurgy. Mechanical Metallurgy. Corrosion.

Mineral Products. Porcelain and Pottery. Glass. Refractories. Enameled Metals. Concreting Materials. Constitution and Microstructure.

Building Technology. Structural Engineering. Fire Protection. Heating and Air Conditioning. Floor, Roof, and Wall Coverings. Codes and Specifications.

Applied Mathematics. Numerical Analysis. Computation. Statistical Engineering.

Electronics. Engineering Electronics. Electron Tubes. Electronic Computers. Electronic Instrumentation. Process Technology.

Radio Propagation. Upper Atmosphere Research. Ionospheric Research. Regular Propagation Services. Frequency Utilization Research. Tropospheric Propagation Research. High Frequency Standards. Microwave Standards.

● Office of Basic Instrumentation

● Office of Weights and Measures.

NATIONAL BUREAU OF STANDARDS REPORT

NBS PROJECT

NBS REPORT

1002-10-1029

April 13, 1954

3229

PRELIMINARY EXPERIMENTS

WITH A

RADIANT PANEL FLAME-SPREAD TEST METHOD

by

A. F. Robertson, R. Kreisler and D. Gross



**U. S. DEPARTMENT OF COMMERCE
NATIONAL BUREAU OF STANDARDS**

The publication, reprint, or translation of this report is prohibited unless permission is obtained from the National Institute of Standards and Technology, Gaithersburg, Maryland 20899. Such permission may be obtained by contacting the National Institute of Standards and Technology, Gaithersburg, Maryland 20899.

Approved for public release by the
Director of the National Institute of
Standards and Technology (NIST)
on October 9, 2015.

part, is prohibited
dards, Washington
rt has been specifi-
rt for its own use.

Preliminary Experiments

with a

Radiant Panel Flame-Spread Test Method

by

A. F. Robertson, R. Kreisler and D. Gross

Abstract

A flame spread test method for wall surfacing materials involving the use of a radiant panel heat source is described. Measurements have been made of the energy flux field in front of the panel and at the surface of the specimen as mounted for test. A method for standardization of radiant output is described. Flame spread data are presented for a number of both organic and mineral base materials. Limitations and significance of the test method together with recommendations for further study are included.

1. INTRODUCTION

For many years a simple quantitative test for determining the flame spread characteristics of small samples of building materials has been needed by both industry and government. Federal Specification SS-A-118a describes a method for evaluating the fire hazard of prefabricated acoustical tile, however, the method used is not one suitable for evaluation and expression of the flame spread characteristics in quantitative terms. The ASTM currently is considering a tunnel test method developed by Underwriters Laboratories. This test method involves use of large specimens and requires installation and operation of expensive and bulky equipment.

The present report describes a preliminary study of a new method suggested as a possible means for evaluation of flame spread of finish materials. The apparatus is somewhat similar to one used by the British Fire Research Board, reference [1]. Factors considered in selection of the apparatus involved the following: (a) The method should if possible be suitable for quality control, and product development tests by the manufacturer as well as for fire spread evaluation by a test laboratory. (b) The method used should yield quantitative reproducible results. (c) The method should require the use of relatively compact and inexpensive test equipment. (d) Specimen size and the time required for performance of the test should not be large.

Work accomplished to date on study of the method includes the following: (a) Assembly of the radiant panel and auxiliary equipment, (b) Calibration of the heat output of the panel, (c) Preliminary study of flame spread rate of finish materials.

2. TEST APPARATUS

The apparatus used for the tests described consisted of a radiant panel with its associated gas-air supply and controls, a frame for support of the test specimen, a calorimeter for measuring and permitting standardization of the heat output. Fig. 1 presents a photograph of the assembly as used for some of the work. Here the radiant panel is near the upper center of the picture just below the hood. The specimen support frame is to the left, and the water cooled shutter is at the right of the panel. A filter, lower right cleans air entering the blower. This blower supplies the gas-air mixture to the panel by means of the vertical pipe and a venturi gas-air mixer, the latter not shown in the photograph.

It will be recognized that the apparatus described is in many ways similar to that described in British Standard BS 476, 1953, reference (1). The use of the particular radiant panel and general method of test was suggested by reports made available by the Fire Research Station of Department of Scientific and Industrial Research, England. However, most of the work reported here was done before BS 476, 1953, which describes an "Apparatus for Preliminary Surface Spread of Flame Test", was released for distribution.

2.1 Radiation Panel

The radiant panel Fig. 1 & 2 consists of a cast iron frame enclosing a porous refractory material which was imported from England*. The panel is mounted in a vertical plane. It is fed from the rear with a pre-mixed gas-air supply, combustion of which is nearly completed within its pores. After warm-up, the only visible flames from the panel surface are less than 1/8 in. in length. The panel approaches its equilibrium temperature of approximately 800°C in about 25 minutes after ignition. Three different types of calorimeters are investigated for monitoring the output of this panel. These included the water cooled shutter, the copper disc calorimeter, and the radiation pyrometer.

2.2 Water-Cooled Shutter

A water-cooled shutter was constructed as a possible method of measuring and monitoring the heat output of the panel. This shutter shown at the side of the panel, Fig. 1, consisted of a

*The panel used for the tests reported was manufactured by Radiant Heating Ltd., Barnsbury Park, London, N. 1. It is 12 in. square, their Type 1 surface combustor.

12 x 12 x 7/8 in. copper tank, one wall of which was formed of a copper sheet 18 in. square and 1/16 in. thick. Water was circulated through this tank which was mounted on a set of rollers to facilitate movement to and from a position in front of the radiant panel.

2.3 Disc Calorimeter

This calorimeter consisted of a copper disc with a copper-constantan thermocouple swaged into its rear surface, Fig. 3 & 5. The front face was coated with acetylene black the remainder being polished. It was supported by wires within a cylindrical stainless steel shield which in turn was supported by fine wires within a frame used for positioning it before the panel. The shield was used in an attempt to reduce heat transfer by convection between the back of the disc and ambient gases.

2.4 Test Specimen Holder

A holder made of 1" angle iron which could be set at various distances from and angles to the radiant panel was used to hold the 6" x 12" samples for the test. This frame, Fig. 1 & 2, was hinged to permit loading new specimens outside the radiation field.

2.5 Timer

A record of the time of start of a test as well as the initiation of flaming and progress of the flame front past various stations along the length of the specimen was secured by means of an electrically operated paper tape chronograph.

3. TEST METHODS AND RESULTS

The work reported here involved the study of a new test method. Because of this no strictly uniform test procedure was used through all the tests performed. The test methods mentioned below are those used for the greater part of the work.

3.1 Performance of Radiant Panel

(a) Measurement of Radiant Output

A test method such as the one proposed requires a simple positive method of standardization of the energy output of the radiant panel. Since it is energy output rather than panel temperature that determines the heat transfer rate, it is desirable that the method used for standardization of this rate measure radiant energy rather than panel temperature. The emissivity of the panel surface is likely to change with use and thus measurement and control of panel temperature does not provide an effective means of control of radiant energy output. As mentioned earlier

three different methods were used for measuring output of the panel, these included the water cooled shutter, the disc calorimeter, and a wide angle radiation pyrometer. The latter device proved the most practical but was used for only the latter part of the experimental study. In use this pyrometer was sighted on the 10 in. diameter circular central area of the panel.

Measurements with both an optical and radiation pyrometer permitted an estimate to be made of the surface temperature and emissivity. These were found to be 790°C and 0.70 respectively. Temperature variations across the heated face of the panel were estimated to be on the order of 48°C. During a series of 40 tests performed over a period of 13 days, it was found easy to maintain the energy output by means of the radiation pyrometer within $\pm 5\%$.

The total rate of heat output of the radiant panel was estimated to be 6300 cal/sec or about 26 kilowatt. This estimate is based on the known gas supply rate and the heating value of this gas. From the measured panel temperature and emissivity it is estimated that only 17% of this heat output is released as radiant energy.

(b) Energy Field

The energy field produced by the panel was surveyed by means of the disk calorimeter and a high speed recording potentiometer. The calorimeter was, as mentioned previously, surrounded by a shield in an effort to reduce convection heat transfer between the back of it and ambient gases. Fig. 5 shows a sketch of this calorimeter as used for these tests.

In surveying the energy field before the plate a grid system was selected and defined as shown in Fig. 6. Measurements were made at various distances perpendicular to the panel face at many of the coordinates marked here. Figs. 7, 8 and 9 present the result of these measurements for four of the vertical planes defined in fig. 6. Fig. 8 presents a plot of the panel, as measured for four of the coordinates lying in a horizontal plane passing thru the center of the panel.

The measured energy intensities just mentioned were considerably different from those effective in heating specimens when exposed during test. Fig. 9 shows the results of measurements made when the energy field was changed by introduction of a dummy specimen of incombustible material within which the calorimeter could be mounted. This was accomplished by boring a number of holes through the specimen within which the disc calorimeter could be mounted with its surface flush with the specimen. When making these measurements the unused holes were plugged to present a continuous unbroken surface. The considerable increase in measured intensity near

the top of the specimen must be due to heating by convection from the hot furnace gases. The crossing of the curves near the center of the specimen was unexpected but may possibly have resulted from poor control of radiant output of the panel as these measurements were made prior to adoption of the radiation pyrometer as a standardization procedure.

3.2 Flame Spread Tests

(a) Specimen Orientation

During initial tests it was found that orientation of the specimen in a vertical plane, similar to that mentioned in BS 476, resulted in a curved flame front the position of which was hard to define at a given time. In other tests of specimens having surfaces finished with a fire retardant paint it was found that ignition and burning took place on the edges and back of the specimen rather than on the surface exposed to radiation.

Several other specimen positions were tried and it appeared that a favorable arrangement involved placing the specimen face down inclined at an acute angle to the surface of the radiant panel. With the specimen in the position shown in figure 4, it was ignited across the top and the flame front, which for homogeneous materials was nearly straight, was not obscured by smoke and flames, therefore its progress down the specimen was easy to follow. It was because of these advantages that this position was chosen for the tests herein reported.

(b) Test Procedure

In performing the flame spread tests the radiant panel was ignited and allowed to heat for about 25 minutes. The radiant output was then measured and if necessary adjusted with the aid of the radiation pyrometer. A small pilot flame was located above but not in contact with the upper edge of the specimen to ignite combustible gases leaving the specimen during radiant exposure. A pre-conditioned test specimen was then mounted in the holder and after starting the chronograph tape the specimen was swung into position in front of the panel. An electrical push button switch was used in the timing marker circuit and was actuated at specimen exposure, ignition, and arrival of the flame front at the 3, 6, 9, and 12 inch stations along the length of the specimen.

The duration of the radiant exposure varied from less than a minute to over three minutes depending on the behavior of the specimen being tested. It was estimated that when testing a number of specimens, the average time interval required per unit would be about five minutes.

(c) Typical Test Results

Table I presents a list of various organic-base materials which have been tested. A plot of the position of the flame front vs time for two specimens of each of these materials is shown in figure 10. Table II and Fig. 11 presents similar data on several composite or mineral base materials tested. Fig. 12 presents data taken over a period of 12 days during 6 of which tests were performed on similar specimens of a factory finished fiber board. This gives some indication of the day to day reproducibility of data on a given specimen.

4. DISCUSSION

Study of the flame spread-time data of figures 10, 11, and 12 indicate an initial rapid flame spread over the first 3 to 6 in. of the specimen with a slower progress over the remaining exposed face. Referring to figure 9 it will be observed that performance such as this is to be expected since the energy flux incident on the specimen decreases very rapidly in the range from 0 to 4 in. It seems quite likely that more uniform rate of flame spread over the specimen face could, if desirable, be achieved by modification of the position of the specimen with respect to the radiant panel.

Experience with the test method has indicated that the tests are simple to perform and tests on 10 or 12 specimens can be completed within an hour. Such repetitious testing would however require modification of the specimen support frame. It is believed that a number of light sheet metal or wire frames which could be clipped onto the radiant panel would be more desirable both from the standpoint of preventing preheating of the specimen before exposure, and maintenance of a standardized specimen location with respect to the radiant source.

No attempt has as yet been made to define the scale by which flame spread hazard of the various materials would be specified when a test method such as this is used. This might be done in a number of different ways:

1. Flame spread rate at a given position along the specimen length.
2. Time after exposure required for flame to travel a given length on the specimen.
3. Combination of 1 or 2 and maximum flame spread observed on specimen.

Method 1 appears to give a sensitive indication of flame spread covering the range of 1.6 in./min to 15.6 in./min for the 9 in. position and the materials shown in figure 10. Figure 12 indicates that the 6 or 9 in. positions would probably be the most desirable ones at which this flame spread rate should be measured. Selection of one of these stations would, however, provide an indeterminate classification for materials such as two of those shown in figure 11 where the slope of the time distance curve is uncertain because the flame did not travel the full length of the specimen.

A test method of the type described does not provide a quantitative method for distinguishing between materials which exhibit a large heat release on combustion and those which do not. An example of this is the mineral base acoustic tile No. 12 which exhibits initial flame spread characteristics quite similar to some of the organic base materials but is known to release only a small amount of heat on combustion. A measurement of the heat release of the materials tested might be made by determining the maximum exhaust gas temperature. This difficulty is not unique to the test method as it is also encountered with the tunnel test methods now under study by ASTM.

5. RECOMMENDATIONS FOR FURTHER STUDY

It is suggested that as time and man power are available study of this test method should continue. The following factors seem to require further experimental work:

1. Revision of the specimen support frame.
2. Installation of some sort of short stack above the upper end of the specimen to permit measurement of exhaust gas temperature and smoke produced by the specimen.
3. Study of ambient variables on test results.
4. Study of desirable conditioning and pre-test storage methods to be used for specimens.
5. Perform a series of tests on a wide variety of materials and if possible obtain a correlation with other flame spread test methods.

6. REFERENCE

1. British Standard BS476-1953 "Fire Tests on Building Materials and Structures" British Standards Institution, 2 Park Street, London W1.

This standard may be obtained from the British Information Services, 30 Rockefeller Plaza, New York 20, New York.

Table I

Organic Base Materials Tested

Specimen No.	Type	Surface Finish	Bulk Density lb/ft ³	Moisture Content %	Manufacturer
1	Non perforated wood fiber acoustic tile	None	10.6	7.8	A
2	Perforated cane fiber acoustic tile	Paint	16.3	7.6	B
3	Wood fiber board	None	16.4	8.3	C
4	Cane fiber board	None	17.6	7.3	B
5	Cane fiber board	Factory paint	20.3	---	B
6	Wood fiber board	Factory paint	21.0	8.0	D
7	Sugar pine	None	27.0	8.6	-
8	Poplar	None	29.1	8.9	-
9	Yellow pine	None	34.6	9.9	-
10	Sugar maple	None	40.7	7.4	-

Table II

Composite or Mineral Base Materials Tested

Specimen No.	Type	Base Material	Surface Finish	Bulk Density lb/ft ³	Moisture Content %	Mfgr	Remarks
11	Acoustic tile	Glass fiber	Plastic film	5.8	----	E	Surface film cracks and chars, specimen glows without open flame.
12	Acoustic tile	Mineral fiber	Paint	19.8	1.7	C	Weak flame
13	Gypsum lath	Gypsum	Paper		----	-	Flame spread was slower when paper fibers lay parallel to flame front i.e. when specimen was cut across lath width.
14	Protected metal	Steel plate	Compounded	---	----	F	Specimen less than 9 in. in length.

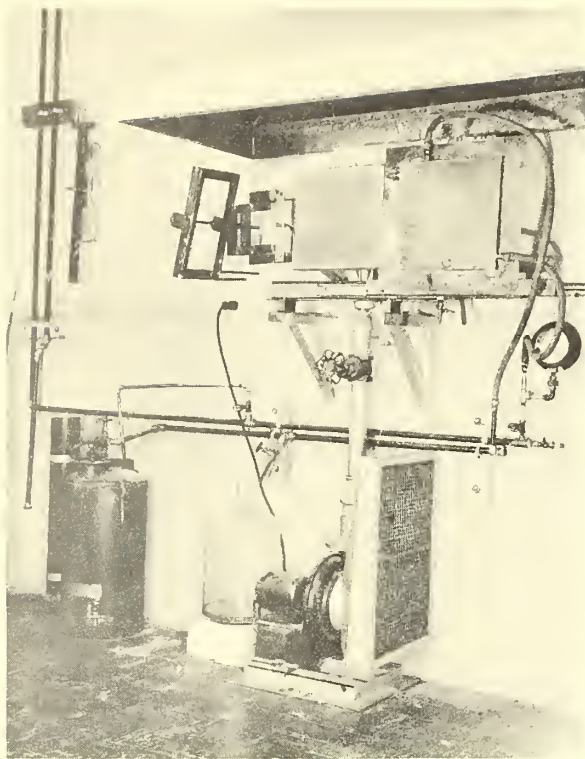

FIG. 1

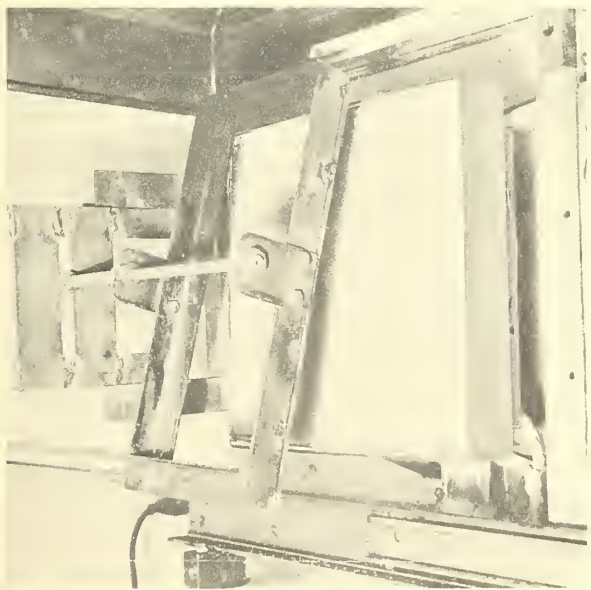

FIG. 2

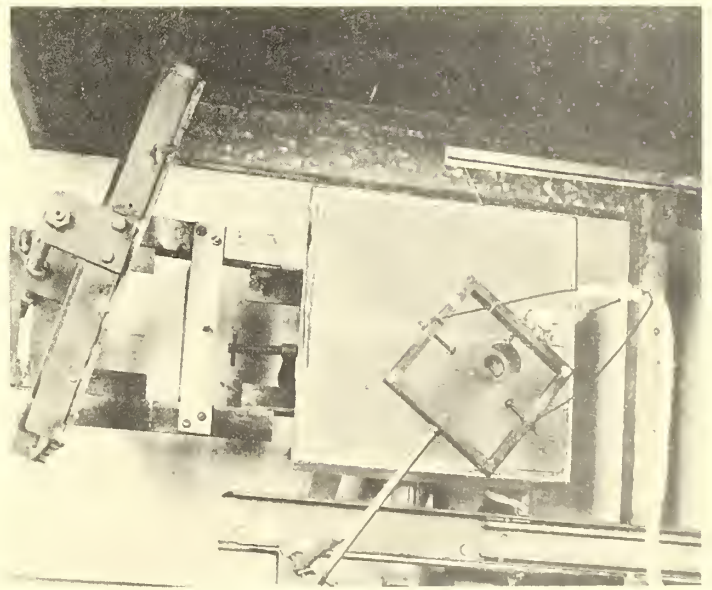

FIG. 3

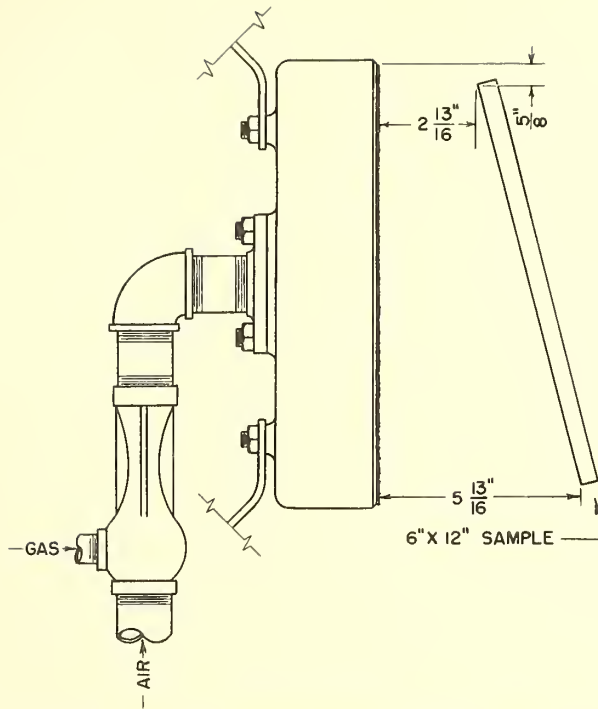

FIG. 4 POSITION OF SAMPLE WITH RESPECT TO FURNACE

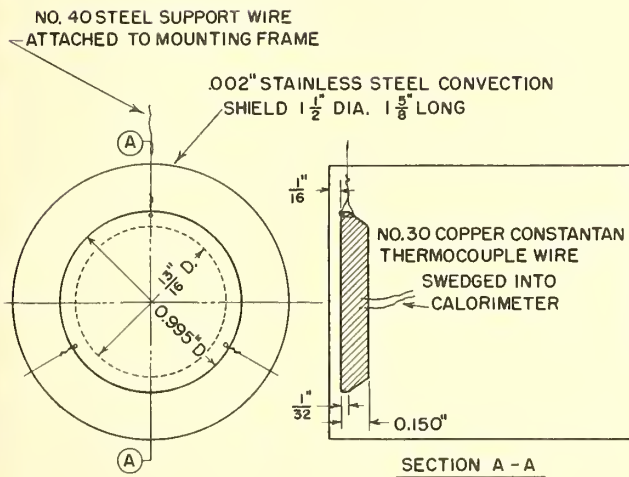

FIG. 5 COPPER CALORIMETER

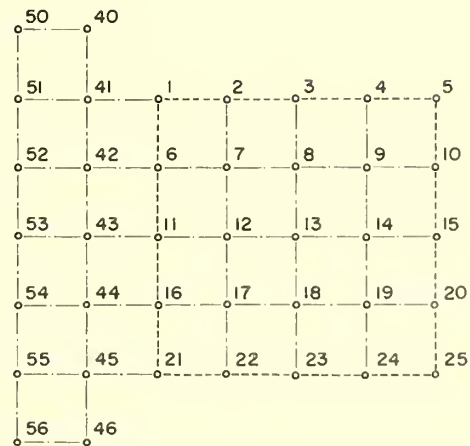
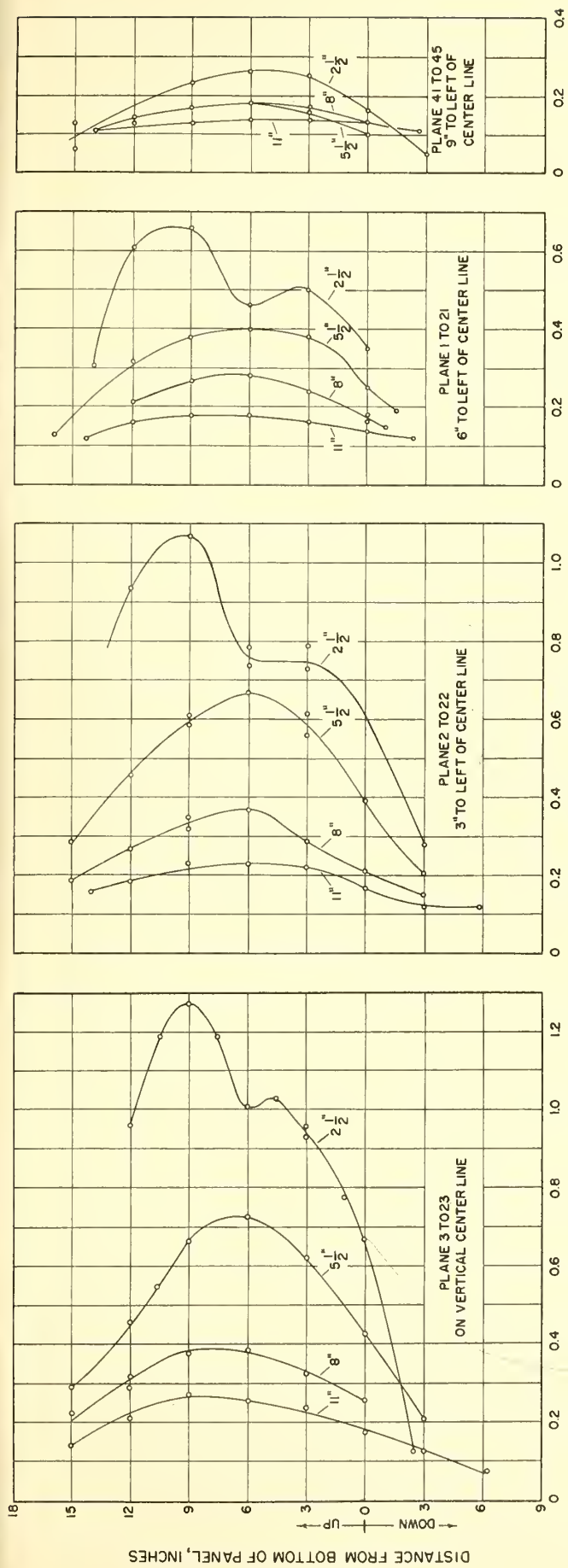
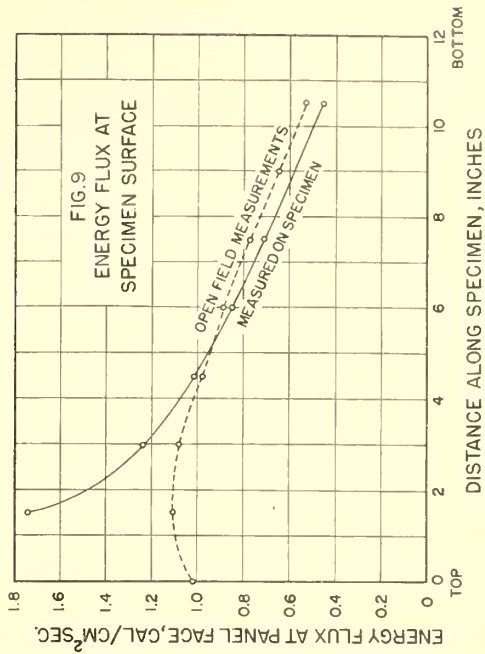
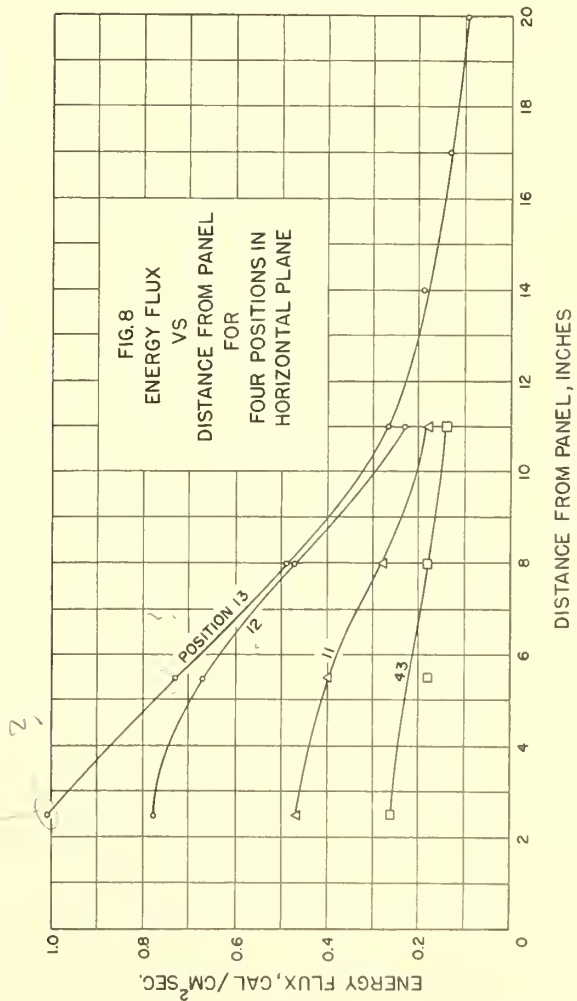

FIG. 6 CALORIMETER LOCATIONS
POSITIONS DEFINED BY NUMBERED POINTS ON 3" RECTANGULAR
GRID PATTERN - DOTTED LINE INDICATES FURNACE OUTLINE



ENERGY FLUX, CAL / CM² SEC

FIG. 7 OPEN FIELD DISC CALORIMETER MEASUREMENTS



DISTANCE FROM BOTTOM OF PANEL, INCHES

ENERGY FLUX, CAL / CM² SEC.

DISTANCE FROM PANEL, INCHES

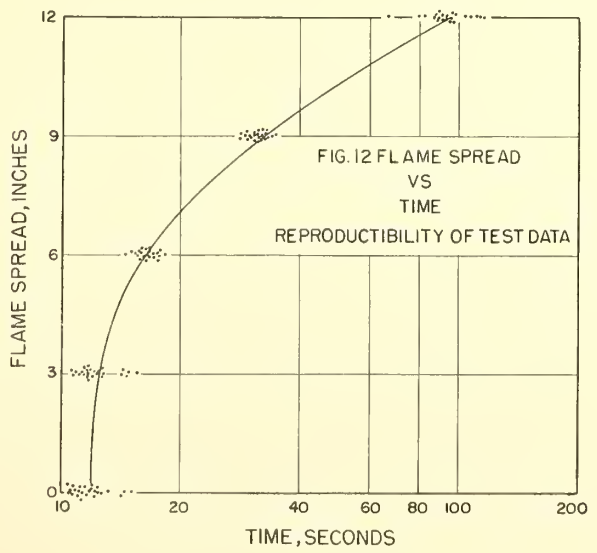
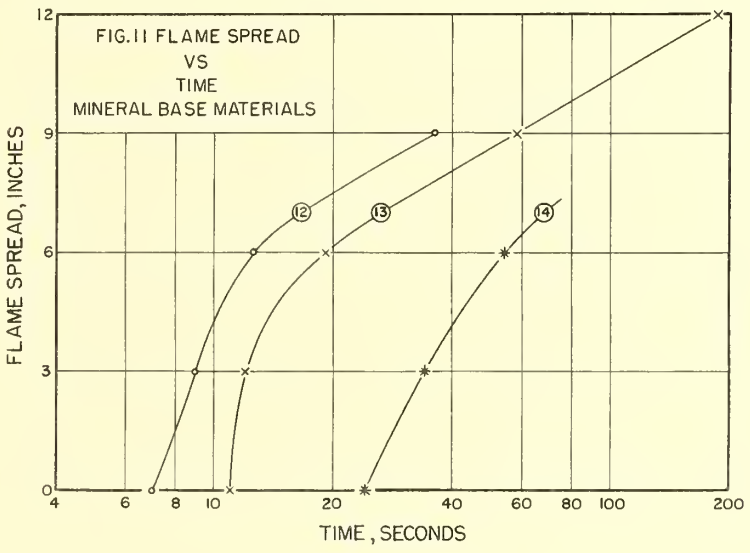
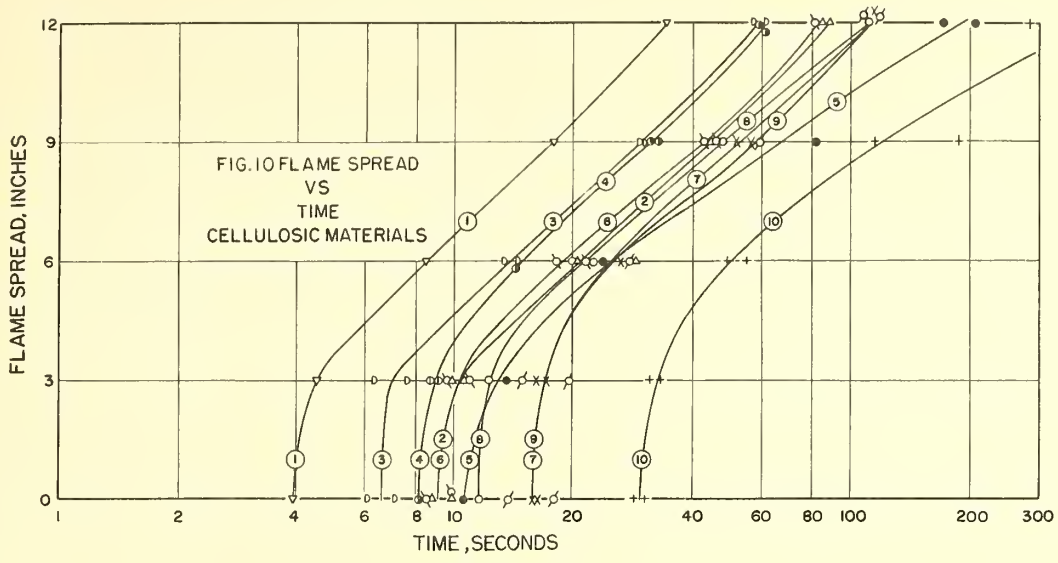

THE NATIONAL BUREAU OF STANDARDS

Functions and Activities

The functions of the National Bureau of Standards are set forth in the Act of Congress, March 3, 1901, as amended by Congress in Public Law 619, 1950. These include the development and maintenance of the national standards of measurement and the provision of means and methods for making measurements consistent with these standards; the determination of physical constants and properties of materials; the development of methods and instruments for testing materials, devices, and structures; advisory services to Government Agencies on scientific and technical problems; invention and development of devices to serve special needs of the Government; and the development of standard practices, codes, and specifications. The work includes basic and applied research, development, engineering, instrumentation, testing, evaluation, calibration services, and various consultation and information services. A major portion of the Bureau's work is performed for other Government Agencies, particularly the Department of Defense and the Atomic Energy Commission. The scope of activities is suggested by the listing of divisions and sections on the inside of the front cover.

Reports and Publications

The results of the Bureau's work take the form of either actual equipment and devices or published papers and reports. Reports are issued to the sponsoring agency of a particular project or program. Published papers appear either in the Bureau's own series of publications or in the journals of professional and scientific societies. The Bureau itself publishes three monthly periodicals, available from the Government Printing Office: The Journal of Research, which presents complete papers reporting technical investigations; the Technical News Bulletin, which presents summary and preliminary reports on work in progress; and Basic Radio Propagation Predictions, which provides data for determining the best frequencies to use for radio communications throughout the world. There are also five series of nonperiodical publications: The Applied Mathematics Series, Circulars, Handbooks, Building Materials and Structures Reports, and Miscellaneous Publications.

Information on the Bureau's publications can be found in NBS Circular 460, Publications of the National Bureau of Standards (\$1.00). Information on calibration services and fees can be found in NBS Circular 483, Testing by the National Bureau of Standards (25 cents). Both are available from the Government Printing Office. Inquiries regarding the Bureau's reports and publications should be addressed to the Office of Scientific Publications, National Bureau of Standards, Washington 25, D. C.

