

NISTIR 7036

**Results from Laboratory Testing of
Embedded Air Handling Unit and Variable
Air Volume Box Fault Detection Tools**

**Jeffrey Schein
Steven T. Bushby**

U.S. DEPARTMENT OF COMMERCE
National Institute of Standards and Technology
Building Environment Division
Building and Fire Research Laboratory
Gaithersburg, MD 20899-8631

John M. House
Iowa Energy Center
Ames, IA

NIST

National Institute of Standards and Technology
Technology Administration, U.S. Department of Commerce

NISTIR 7036

**Results from Laboratory Testing of
Embedded Air Handling Unit and Variable
Air Volume Box Fault Detection Tools**

Jeffrey Schein
Steven T. Bushby

*U.S. DEPARTMENT OF COMMERCE
National Institute of Standards and Technology
Building Environment Division
Building and Fire Research Laboratory
Gaithersburg, MD 20899-8631*

John M. House
*Iowa Energy Center
Ames, IA*

August 2003

U.S. Department of Commerce
Donald L. Evans, *Secretary*
Technology Administration
Phillip J. Bond, *Under Secretary for Technology*
National Institute of Standards and Technology
Arden L. Bement, Jr., *Director*



Abstract

Building HVAC equipment routinely fails to satisfy performance expectations envisioned at design. Such failures often go unnoticed for extended periods of time. Additionally, higher expectations are being placed on a combination of different and often conflicting performance measures, such as energy efficiency, indoor air quality, comfort, reliability, limiting peak demand on utilities, etc. To meet these expectations, the processes, systems, and equipment used in both commercial and residential buildings are becoming increasingly sophisticated. This development both necessitates the use of automated diagnostics to ensure fault-free operation and enables diagnostic capabilities for the various building systems by providing a distributed platform that is powerful and flexible enough to perform fault detection and diagnostics (FDD).

The purpose of the research effort described in this report is to develop, test, and demonstrate FDD methods that can detect common mechanical faults and control errors in air-handling units (AHUs) and variable-air-volume (VAV) boxes. The tools are intended to be sufficiently simple that they can be embedded in commercial building control systems and rely upon only sensor data and control signals that are commonly available in commercial building automation and control systems.

AHU Performance Assessment Rules (APAR) is a diagnostic tool that uses a set of expert rules derived from mass and energy balances to detect faults in air-handling units. Control signals are used to determine the mode of operation for the AHU. A subset of the expert rules corresponding to that mode of operation is then evaluated to determine if there is a mechanical fault or a control problem. VAV box Performance Assessment Control Charts (VPACC) is a diagnostic tool that uses statistical quality control measures to detect faults or control problems in VAV boxes.

This report describes a research study of embedding APAR and VPACC in HVAC equipment controllers in a laboratory setting. APAR was embedded in several air handling unit controllers and evaluated in an emulation environment, while VPACC was embedded in several VAV box controllers and evaluated in a laboratory environment. APAR and VPACC were both found to be successful at finding a wide variety of mechanical and control faults. Both tools appear to be suitable for embedding in commercial control products.

Key words: BACnet, building automation and control, direct digital control, energy management systems, fault detection and diagnostics, cybernetic building systems

Acknowledgments

This work was supported in part by the U.S. Department of Energy Office of Energy Efficiency and Renewable Energy. In addition, this project would not have been possible without the assistance of many individuals. Thanks are due to Cheol Park and Michael Galler of the National Institute of Standards and Technology for their assistance with the emulation aspect of the project and Xiaohui Zhou of the Iowa Energy for his assistance with the laboratory aspect of this project.



National Institute of Standards and Technology
Technology Administration, U.S. Department of Commerce

Table of Contents

1	Introduction	5
2	Methodology	6
2.1	FDD for Air Handling Units	6
2.1.1	System Description	6
2.1.2	AHU Performance Assessment Rules (APAR)	7
2.1.3	Instrumentation Accuracy Requirements	12
2.2	FDD for VAV Boxes.....	13
2.2.1	VAV box Performance Assessment Control Charts - VPACC.....	13
2.2.2	Control Charts	13
2.2.3	System Description	15
2.2.4	CUSUM Applied to VAV Box Diagnostics	16
2.2.5	Point requirements.....	18
2.2.6	Parameters	18
2.2.7	Special Cases.....	18
3	Testing Environment	20
3.1	VCBT	20
3.1.1	AHU Control Strategies	20
3.1.2	Embedded APAR	21
3.1.3	VCBT Fault Descriptions.....	22
3.2	ERS.....	23
3.2.1	Embedded VPACC	23
3.2.2	ERS Fault Descriptions	24
4	Results	26
4.1	VCBT	26
4.1.1	Outdoor Air Temperature Sensor Failure.....	27
4.1.2	Mixed Air Temperature Sensor Drift.....	27
4.1.3	Recirculation Damper Stuck Closed	29
4.1.4	Economizer Control Logic Fault.....	31
4.2	ERS.....	35
5	Summary and Future Work.....	37
6	References	38

1 Introduction

Building HVAC equipment routinely fails to satisfy performance expectations envisioned at design. Such failures often go unnoticed for extended periods of time. Additionally, higher expectations are being placed on a combination of different and often conflicting performance measures, such as energy efficiency, indoor air quality, comfort, reliability, limiting peak demand on utilities, etc. To meet these expectations, the processes, systems, and equipment used in both commercial and residential buildings are becoming increasingly sophisticated. This development both necessitates the use of automated diagnostics to ensure fault-free operation and enables diagnostic capabilities for the various building systems by providing a distributed platform that is powerful and flexible enough to perform fault detection and diagnostics (FDD).

Most of today's emerging FDD tools are stand-alone software products that do not reside in a building control system. Thus, trend data files must be processed off-line, or an interface to the building control system must be developed to enable on-line analysis. This does not scale well because all of the data must be obtained at a single point. A better solution is to embed FDD in the local controller for each piece of equipment, so that the FDD algorithm is executed as a component of the control logic. NIST has developed FDD methods that can detect common mechanical faults and control errors in air-handling units (AHUs) and variable-air-volume (VAV) boxes. The tools are sufficiently simple that they can be embedded in commercial building control systems and only rely upon sensor data and control signals that are commonly available in commercial building automation and control systems. AHU Performance Assessment Rules (APAR) and VAV box Performance Assessment Control Charts (VPACC) have been designed "from the ground up" to be embedded in commercial HVAC equipment controllers.

A previous study [1], describes the theoretical basis of APAR and VPACC and evaluates the tools' performance using data generated by simulation, emulation, and laboratory testing. The study examined the breadth of faults that can be detected and the conditions under which they can be detected. This report describes the results of a research study to evaluate the feasibility of embedding APAR and VPACC in HVAC equipment controllers in a laboratory setting.

2 Methodology

2.1 FDD for Air Handling Units

The fault detection tool described in this section was developed for application to single duct variable-volume or constant-volume air handlers with hydronic heating and cooling coils and airside economizers. The rules that are used for FDD focus on temperature control in an AHU. Hence, the system description will be restricted to components and control strategies directly related to temperature control. Figure 2.1 is a schematic diagram of a typical single duct air handling unit (AHU).

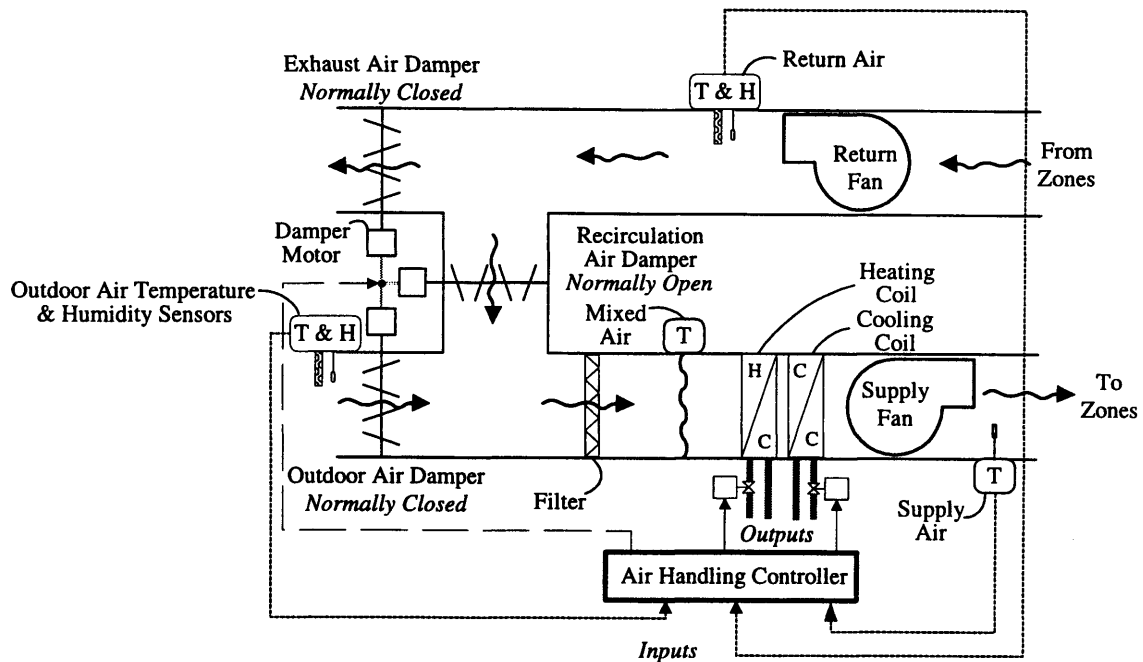

Figure 2.1: Schematic diagram of a single duct air-handling unit

2.1.1 System Description

The AHU controller typically controls the supply air temperature to maintain a setpoint temperature at a location in the supply duct downstream of the supply fan. Outdoor air enters the AHU and is mixed with air returned from the building. A single mixing box damper control signal is mapped to the outdoor air damper, the exhaust air damper, and the recirculation air damper. A control signal of 100 % means that the dampers are positioned for 100 % outdoor air (outdoor and exhaust air dampers are fully open and recirculation air damper is fully closed); a control signal of 0 % means that the dampers are aligned for 0 % outdoor air (outdoor and exhaust air dampers are fully closed and recirculation air damper is fully open). The mixed air passes over the heating and cooling coils, where if necessary, it is conditioned prior to being supplied to the building. The typical operating sequence for AHUs consists of four primary modes of operation during

occupied periods for maintaining the supply air temperature and the ventilation at preset levels. The relationship of the four operating modes to the control of the heating coil valve, the cooling coil valve and the mixing box dampers is shown in Figure 2.2. Sequencing logic determines the mode of operation as dictated by various thermal relationships including the internal and external loads on the zones served by the AHU.

In the heating mode (Mode 1 in Figure 2.2), the heating coil valve is controlled to maintain the supply air temperature at the heating set point and the cooling coil valve is closed. The mixing box dampers are positioned to allow the minimum outdoor air necessary to satisfy ventilation requirements.

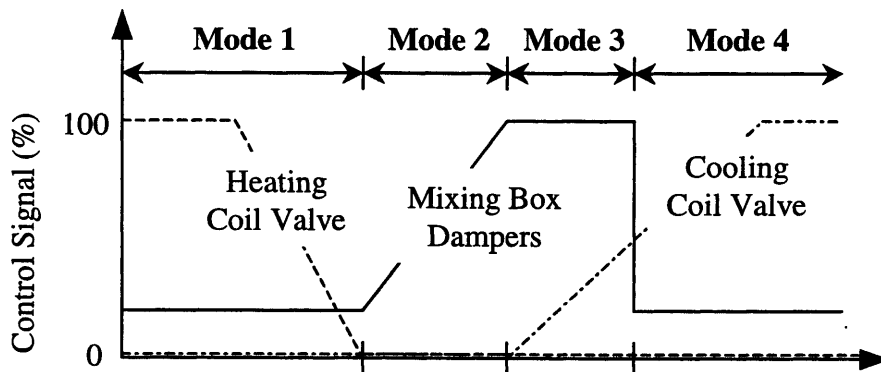

Figure 2.2: Typical operating modes of an air-handling unit

As cooling loads increase, the AHU transitions from heating to cooling with outside air (Mode 2). In this mode, the heating and cooling coil valves are closed and the mixing box dampers are modulated to maintain the supply air temperature at cooling set point. As the loads continue to increase, the mixing dampers eventually saturate with the outdoor air damper fully open and the AHU changes over to mechanical cooling. When the AHU is operating in one of the mechanical cooling modes (Modes 3 and 4), the cooling coil valve modulates to maintain the supply air temperature at cooling set point, the heating coil valve is closed, and the outdoor air damper is either fully open or at its minimum position. There are several different types of economizer controls, generally the economizer control logic uses a comparison of the outdoor and return air temperatures or enthalpies to determine the proper position of the outdoor air damper such that mechanical cooling requirements are minimized. Hence, the third primary mode (Mode 3) of operation is mechanical cooling with 100 % outdoor air and the fourth primary mode (Mode 4) of operation is mechanical cooling with minimum outdoor air.

2.1.2 AHU Performance Assessment Rules (APAR)

The basis for the fault detection methodology is a set of expert rules used to assess the performance of the AHU. The tool developed from these rules is referred to as APAR (AHU Performance Assessment Rules). APAR uses control signals and occupancy information to identify the mode of operation of the AHU, thereby identifying a subset of the rules that specify temperature relationships that are applicable for that mode. The two main mode classifications are occupied and unoccupied. For occupied periods, the mode is further categorized as described in the previous paragraph. For convenience, the

operating modes are summarized below:

- Mode 1: heating
- Mode 2: cooling with outdoor air
- Mode 3: mechanical cooling with 100 % outdoor air
- Mode 4: mechanical cooling with minimum outdoor air
- Mode 5: unknown

Because the direct digital control (DDC) output to the actuators of the heating and cooling coil valves and the mixing box dampers are known, the mode of operation can be ascertained. Although not depicted in Figure 2.2, a fifth mode of operation referred to “unknown” operation has been defined and listed above. The unknown mode applies to the case in which the AHU is running in an occupied mode, but none of the control output relationships defined for Modes 1-4 are satisfied. The unknown mode could be associated with mode transitions and/or with faulty operation such as simultaneous heating and cooling.

Once the mode of operation has been established, rules based on conservation of mass and energy can be used along with the sensor information that is typically available for controlling the AHUs. For example, normal operation in the mechanical cooling mode with 100 % outdoor air (Mode 3) dictates that the outdoor and mixed air temperatures must be approximately equal. Defining T_{oa} and T_{ma} as the outdoor air and mixed air temperatures, respectively, the rule (defined as Rule 10) is written as

$$\text{Rule 10: } |T_{oa} - T_{ma}| > \varepsilon_t$$

where ε_t is a threshold that depends on the uncertainty (or accuracy) of the measurements. The rules are written such that a fault is indicated if a rule is true. In the example above, the rule states that if the outdoor and mixed air temperatures are not the same (i.e., if true) a fault has occurred.

As a detailed description of the 28 APAR rules and the reasoning behind them is available elsewhere [2], the rules are simply listed in Table 2.1 without detailed explanation. Table 2.1 groups the rules according to mode of operation. As indicated in the column heading for the rule expression, a true expression indicates a fault. Table 2.2 presents the rules as related groups and indicates the sensors and control signals used to evaluate each rule. The first group of rules treats the relationship of temperatures in the coil subsystem of the AHU. For these four rules, only the relational operator in the rules change from one mode to another. A typical rule from this subgroup requires the supply air temperature to be lower than the sum of the mixed air temperature and the temperature rise across the supply fan in the mechanical cooling modes. There are also groups of rules treating the mixing box subsystem, the zone subsystem, economizer operation, comfort requirements, and controller logic/tuning. Hence, although there are 28 rules, in reality only a small number of temperature and control signal relationships are used to define the rules.

Table 2.1: APAR Rule Set

Mode	Rule #	Rule Expression (true implies existence of a fault)
Heating (Mode 1)	1	$T_{sa} < T_{ma} + \Delta T_{sf} - \epsilon_t$
	2	For $ T_{ra} - T_{oa} \geq \Delta T_{min}$: $ Q_{oa}/Q_{sa} - (Q_{oa}/Q_{sa})_{min} > \epsilon_f$
	3	$ u_{hc} - 1 \leq \epsilon_{hc}$ and $T_{sa,s} - T_{sa} \geq \epsilon_t$
	4	$ u_{hc} - 1 \leq \epsilon_{hc}$
Cooling with Outdoor Air (Mode 2)	5	$T_{oa} > T_{sa,s} - \Delta T_{sf} + \epsilon_t$
	6	$T_{sa} > T_{ra} - \Delta T_{rf} + \epsilon_t$
	7	$ T_{sa} - \Delta T_{sf} - T_{ma} > \epsilon_t$
Mechanical Cooling with 100% Outdoor Air (Mode 3)	8	$T_{oa} < T_{sa,s} - \Delta T_{sf} - \epsilon_t$
	9	$T_{oa} > T_{co} + \epsilon_t$
	10	$ T_{oa} - T_{ma} > \epsilon_t$
	11	$T_{sa} > T_{ma} + \Delta T_{sf} + \epsilon_t$
	12	$T_{sa} > T_{ra} - \Delta T_{rf} + \epsilon_t$
	13	$ u_{cc} - 1 \leq \epsilon_{cc}$ and $T_{sa} - T_{sa,s} \geq \epsilon_t$
	14	$ u_{cc} - 1 \leq \epsilon_{cc}$
Mechanical Cooling with Minimum Outdoor Air (Mode 4)	15	$T_{oa} < T_{co} - \epsilon_t$
	16	$T_{sa} > T_{ma} + \Delta T_{sf} + \epsilon_t$
	17	$T_{sa} > T_{ra} - \Delta T_{rf} + \epsilon_t$
	18	For $ T_{ra} - T_{oa} \geq \Delta T_{min}$: $ Q_{oa}/Q_{sa} - (Q_{oa}/Q_{sa})_{min} > \epsilon_f$
	19	$ u_{cc} - 1 \leq \epsilon_{cc}$ and $T_{sa} - T_{sa,s} \geq \epsilon_t$
	20	$ u_{cc} - 1 \leq \epsilon_{cc}$
Unknown Occupied Modes (Mode 5)	21	$u_{cc} > \epsilon_{cc}$ and $u_{hc} > \epsilon_{hc}$ and $\epsilon_d < u_d < 1 - \epsilon_d$
	22	$u_{hc} > \epsilon_{hc}$ and $u_{cc} > \epsilon_{cc}$
	23	$u_{hc} > \epsilon_{hc}$ and $u_d > \epsilon_d$
	24	$\epsilon_d < u_d < 1 - \epsilon_d$ and $u_{cc} > \epsilon_{cc}$
All Occupied Modes (Mode 1, 2, 3, 4, or 5)	25	$ T_{sa} - T_{sa,s} > \epsilon_t$
	26	$T_{ma} < \min(T_{ra}, T_{oa}) - \epsilon_t$
	27	$T_{ma} > \max(T_{ra}, T_{oa}) + \epsilon_t$
	28	Number of mode transitions per hour $> MT_{max}$

Where

MT_{max}	=	maximum number of mode changes per hour
T_{sa}	=	supply air temperature
T_{ma}	=	mixed air temperature
T_{ra}	=	return air temperature
T_{oa}	=	outdoor air temperature
T_{co}	=	changeover air temperature for switching between Modes 3 and 4
$T_{sa,s}$	=	supply air temperature set point
ΔT_{sf}	=	temperature rise across the supply fan
ΔT_{rf}	=	temperature rise across the return fan
ΔT_{min}	=	threshold on the minimum temperature difference between the return and outdoor air
Q_{od}/Q_{sa}	=	outdoor air fraction = $(T_{ma} - T_{ra})/(T_{oa} - T_{ra})$
$(Q_{od}/Q_{sa})_{min}$	=	threshold on the minimum outdoor air fraction
u_{hc}	=	normalized heating coil valve control signal [0,1] where $u_{hc} = 0$ indicates the valve is closed and $u_{hc} = 1$ indicates it is 100 % open
u_{cc}	=	normalized cooling coil valve control signal [0,1] where $u_{cc} = 0$ indicates the valve is closed and $u_{cc} = 1$ indicates it is 100 % open
u_d	=	normalized mixing box damper control signal [0,1] where $u_d = 0$ indicates the outdoor air damper is closed and $u_d = 1$ indicates it is 100 % open
ϵ_t	=	threshold for errors in temperature measurements
ϵ_f	=	threshold parameter accounting for errors related to airflows (function of uncertainties in temperature measurements)
ϵ_{hc}	=	threshold parameter for the heating coil valve control signal
ϵ_{cc}	=	threshold parameter for the cooling coil valve control signal
ϵ_d	=	threshold parameter for the mixing box damper control signal

2.1.2.1 Operational and Design Data Requirements

APAR uses the following occupancy information, setpoint values, sensor measurements, and control signals:

- Occupancy status;
- Supply air temperature set point;
- Supply air temperature;
- Return air temperature;
- Mixed air temperature;
- Outdoor air temperature;
- Cooling coil valve control signal;
- Heating coil valve control signal;
- Mixing box damper control signal;
- Return air relative humidity (for enthalpy-based economizers only)
- Outdoor air relative humidity (for enthalpy-based economizers only).

Table 2.2: Summary of Rule Relationships

Rule	Mode ¹	Sensors and Control Signals ²											Relationship Between Grouped Rules	
		T _{sa}	T _{ra}	T _{ma}	T _{oa}	T _{sa,s}	ΔT _{sf}	ΔT _{rf}	T _{co}	U _{cc}	U _{hc}	U _d		
1	1	✓		✓			✓							Coil Subsystem: The relational sign (<, >, etc.) changes based on the mode of operation.
7	2	✓		✓			✓							
11	3	✓		✓			✓							
16	4	✓		✓			✓							
2	1		✓	✓	✓									Mixing Box Subsystem: Rules are related through calculation of outdoor air fraction. If Rule 26 or 27 is satisfied, the outdoor air fraction will be negative or greater than unity.
18	4		✓	✓	✓									
26	1, 2, 3, 4		✓	✓	✓									
27	1, 2, 3, 4		✓	✓	✓									Comfort Requirements: The first four rules indicate comfort is sacrificed (with Rules 3, 13, and 19 indicating the system is out of control), whereas the latter three rules indicate comfort could soon be sacrificed (system is out of control).
25	1, 2, 3, 4	✓				✓								
3	1	✓				✓						✓		
13	3	✓				✓						✓		
19	4	✓				✓						✓		The relational sign (<, >, etc.) changes based on the mode of operation.
4	1												✓	
14	3												✓	
20	4												✓	
5	2				✓	✓	✓							Zone Subsystem: Rules are identical.
8	3				✓	✓	✓							
6	2	✓	✓				✓							
12	3	✓	✓				✓							Economizer: The relational sign (<, >, etc.) changes based on the mode of operation.
17	4	✓	✓				✓							
9	3				✓				✓					
15	4				✓				✓					Controller Logic/Tuning: Rules are related and identify periods of operation associated with controller problems, such as simultaneous heating and cooling, and excessive mode changes.
10	3			✓	✓									
21	-									✓	✓	✓		
22	-									✓	✓	✓		
23	-									✓	✓	✓		
24	-									✓	✓	✓		
28	-									✓	✓	✓		

¹ The dash symbol indicates either an unknown mode or multiple modes of operation.

² The checked box symbol indicates which quantities are compared for the given rule.

This information is generally available for most AHUs controlled with a DDC system. If one or more sensors are not available, certain rules will no longer be applicable. For instance, in the absence of a mixed air temperature sensor, nine rules listed in Table 2.1 (Rules 1, 2, 7, 10, 11, 16, 18, 26, and 27) will be eliminated from consideration in APAR. Conversely, the presence of additional sensors would expand the rule set and provide an opportunity to either detect more faults, or to detect faults during modes of operation in which they would normally be hidden. For instance, if a temperature sensor was installed between the heating and cooling coils, leakage through the heating valve could be detected during the mechanical cooling modes, whereas normally it would be masked in these modes.

In addition to the operational data listed above, certain design data are needed to implement the rules. The required design data are:

- Minimum and maximum values of control signals for the heating coil valve, cooling coil valve and mixing box dampers for normalizing the control signals;
- Percentage outdoor air necessary to satisfy ventilation requirements;
- Changeover temperature from mechanical cooling with 100% outdoor air to mechanical cooling with minimum outdoor air (or equivalent condition for enthalpy-based economizer);
- Description of sequencing/economizer cycle strategy (used to verify that the rules are suitable to a particular AHU installation).

2.1.2.2 Detecting and Diagnosing Faults

APAR does not search for the existence of a specific set of faults. Rather, any fault that causes a rule to be satisfied would be detected and additional effort would be necessary to isolate the source of the problem. Emulation, simulation, and laboratory experimentation from previous work [1] as well as the current study demonstrate that the rule set can identify the following faults:

- Stuck or leaking mixing box dampers, heating coil valves, and cooling coil valves;
- Temperature sensor faults;
- Design faults such as undersized coils;
- Controller programming errors related to tuning, setpoints, and sequencing logic;
- Inappropriate operator intervention.

The operating point, severity of a fault, and threshold selection for the rules will obviously influence when a particular rule is satisfied. Threshold selection is discussed next.

2.1.2.3 Threshold Selection

In addition to the sensor, control signals, and setpoint information, there are other parameters that must be specified for APAR. For instance, estimates of the temperature rise across the supply fan (and return fan, if one exists) must be provided, a reasonable default is 1.1 °C (2.0 °F). A model-based value correlated to the airflow rate or the control signal to the fan could be used as the basis for this estimate; however, some amount of training data would likely be necessary to establish the correlation. Thresholds used in evaluation of rules such as ε_t in Rule 10 must also be specified. Another approach might be to calculate the threshold values based on the uncertainty of each sensor or actuator value. As an example, the threshold in Rule 10 would be determined from the expression

$$\varepsilon_t = \varepsilon_{T_{oa}} + \varepsilon_{T_{ma}}$$

where $\varepsilon_{T_{oa}}$ and $\varepsilon_{T_{ma}}$ are the uncertainties associated with the measurement of the outdoor and mixed air temperatures. If a threshold is too great, the associated fault(s) must be relatively severe to be detected. If, on the other hand, a threshold is too small, normal variation in operating conditions may result in false alarms. These threshold values were determined heuristically for each site of the sites in this study.

2.1.3 Instrumentation Accuracy Requirements

APAR uses existing sensor points in the control system to perform the fault detection calculations. Previous work [1] demonstrated that the typical industrial grade sensors that are already installed for control purposes have sufficient accuracy. Laboratory grade instruments are not required. Higher quality sensors that have been installed and calibrated properly will allow the use of tighter thresholds (less severe faults can be detected) than lower quality sensors, or those that have been poorly calibrated or installed.

2.2 FDD for VAV Boxes

2.2.1 VAV box Performance Assessment Control Charts - VPACC

The primary purpose of heating, ventilating, and air-conditioning (HVAC) equipment in commercial buildings is to provide a comfortable and healthy environment for occupants. Variable-air-volume (VAV) air handling systems are common for conditioning air and delivering the air to occupied zones. VAV boxes are an integral part of such systems and are the final piece of equipment that air passes through prior to reaching the occupants. As such, it is important to ensure that these devices operate correctly.

The challenges presented in detecting and diagnosing faults in VAV boxes are similar to those encountered with other pieces of HVAC equipment. Generally there are very few sensors, making it difficult to ascertain what is happening in the device. Limitations associated with controller memory and communication capabilities further complicate the task. The number of different types of VAV boxes and lack of standardized control sequences add a final level of complexity to the challenge. These constraints make the development of VAV box fault detection tools difficult, but the quantity of VAV boxes makes the effort worthwhile, due to the impact. For instance, buildings may have ten to fifteen times more VAV boxes than air-handling units. Hence, maintenance staffs would clearly benefit from a tool that assisted them in monitoring VAV box operation.

The needs and constraints described above have led to the development of VAV Box Performance Assessment Control Charts (VPACC), a fault detection tool that uses a small number of control charts to assess the performance of VAV boxes. The underlying approach, while developed for a specific type of VAV box and control sequence, is general in nature and can be adapted to other types of VAV boxes. This section describes the basic concept of control charts and their use for determining when control processes have gone “out of control”. The specific control charts developed and implemented in VPACC are then presented for a single duct pressure-independent throttling VAV box with reheat.

2.2.2 Control Charts

Control charts are common tools for monitoring control processes wherein a measured quantity is compared to upper and lower limits that define allowable (or fault free) operation. If the measured quantity falls outside these limits, the process is said to be “out of control.” The limits are typically defined using statistical parameters and, therefore, control charts are often referred to as statistical quality control charts.

There are many different types of control charts. VPACC implements an algorithm known as a CUSUM (cumulative sum) chart. The basic concept behind CUSUM charts is to accumulate the error between a process output and the expected value of the output. Large values of the accumulated error are indicative of an out of control process. With the process output at sampling time i denoted x_i , the estimate of the expected value denoted \hat{x} , and the estimate of the process standard deviation denoted by $\hat{\sigma}$, the normalized process output is given by:

$$z_i = \frac{x_i - \hat{x}}{\hat{\sigma}} \quad (1)$$

The normalized process output is used to compute two cumulative sums defined as follows:

$$S_i = \max [0, z_i - k + S_{i-1}] \quad (2a)$$

$$T_i = \min [0, z_i + k + T_{i-1}] \quad (2b)$$

where k is a slack parameter that must be specified. Positive values of z greater than k cause the sum S to move away from zero and the sum T to approach or remain at zero. Negative values of z less than $-k$ cause the sum T to move away from zero and the sum S to approach or remain at zero. A process is said to be out of control when either S exceeds a threshold value defined by the parameter h , or T falls below $-h$. Figure 2.3 [3] presents normalized data and the S and T cumulative sums for $k = 0.5$ and $h = 5$. The first 20 data points come from a random normal distribution with a mean value of zero and a standard deviation of unity. The mean value is then increased to 0.25, 0.5, 0.75 and 1.0 for subsequent sets of 20 data points. Note that S exceeds the threshold value of h after about 68 data points. Because the mean value increases above 0, the cumulative sum T remains above its threshold of -5 .

CUSUM charts are generally considered to be effective for detecting gradual shifts in the process mean. The most commonly used control charts are Shewhart and Shewhart-type charts. Shewhart charts are effective for detecting large, sudden changes in the process mean. Generally Shewhart chart limits are set at values of $\hat{x} \pm 3\hat{\sigma}$. In terms of the normalized parameter z , the chart limits are $z = \pm 3$. Shewhart charts were not investigated as part of this study; however, it is interesting to note that the basic CUSUM and Shewhart charts are equivalent if the CUSUM parameters k and h are selected as $k = 3$ and $h = 0$.

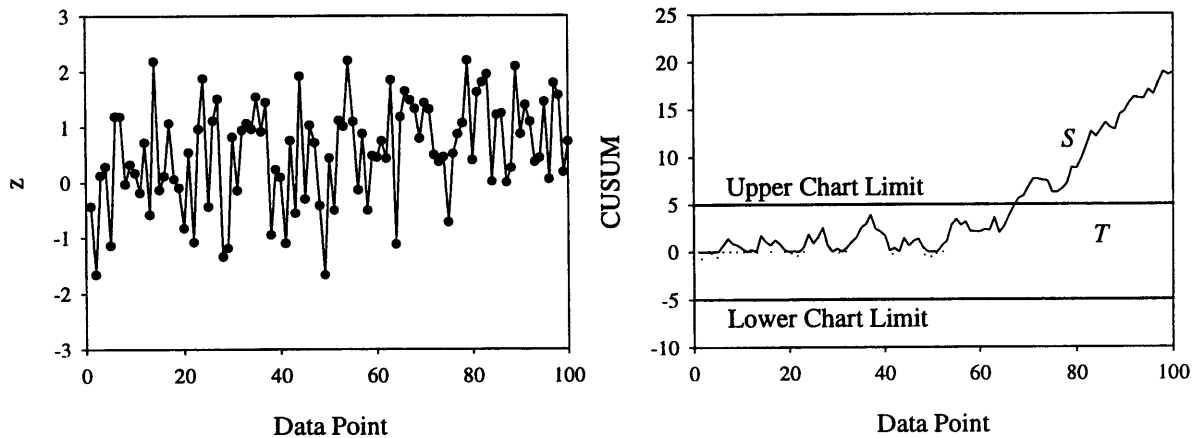

Figure 2.3: A simple CUSUM control chart indicating an “out of control” process.

2.2.3 System Description

Figure 2.4 is a schematic diagram of a typical single duct variable-air-volume (VAV) box with hydronic reheat. The diagram depicts a damper that is used to modulate airflow to the zone and a control valve that modulates hot water flow to the reheat coil. Several sensors are also shown in Figure 2.4. The zone thermostat measures the air temperature in the zone. The differential pressure transducer is used to measure the flow rate of air into the zone. Finally, the discharge air temperature sensor measures the temperature of the air stream entering the zone. This sensor is used to provide diagnostic information rather than for control purposes. The VAV box controller reads the sensor information, computes control outputs for the damper and reheat valve, and transmits these signals to the appropriate actuators.

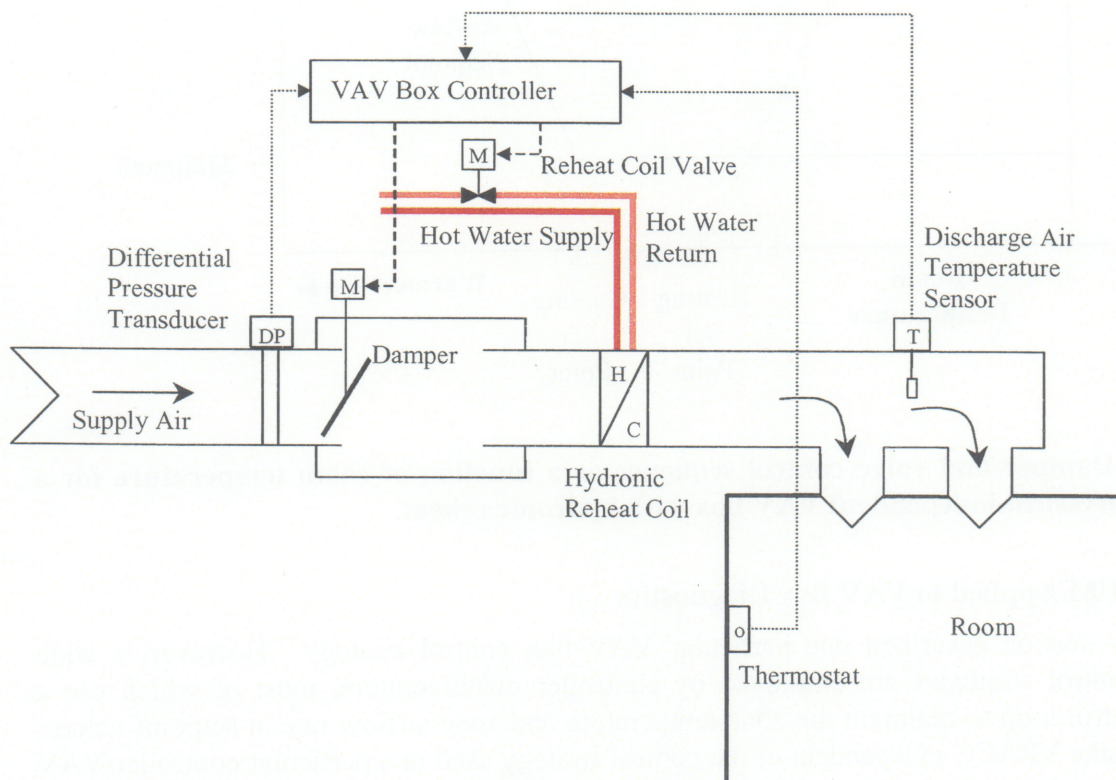

Figure 2.4: Schematic diagram of a single duct pressure-independent VAV box with hydronic reheat.

Figure 2.5 shows a typical control sequence for a pressure-independent VAV box. A heating set point and a cooling set point are specified. As the zone temperature increases above the cooling set point, the airflow rate to the zone increases proportionally. This is accomplished by resetting the airflow rate setpoint and modulating the damper to achieve this airflow rate. As the zone temperature decreases toward the cooling set point, the airflow rate setpoint is decreased and the damper gradually closes until it is providing the minimum flow rate necessary for ventilation. If the room temperature continues to decrease and reaches the heating set point, the reheat valve will begin to open. The airflow rate can also be varied in the heating mode, with the airflow increasing as the temperature decreases. Alternatively, a higher fixed airflow rate may be specified for heating operation to improve the distribution of the warm air. In Figure 2.5, it is

assumed that a fixed airflow rate associated with the ventilation requirement of the room is provided in the heating mode.

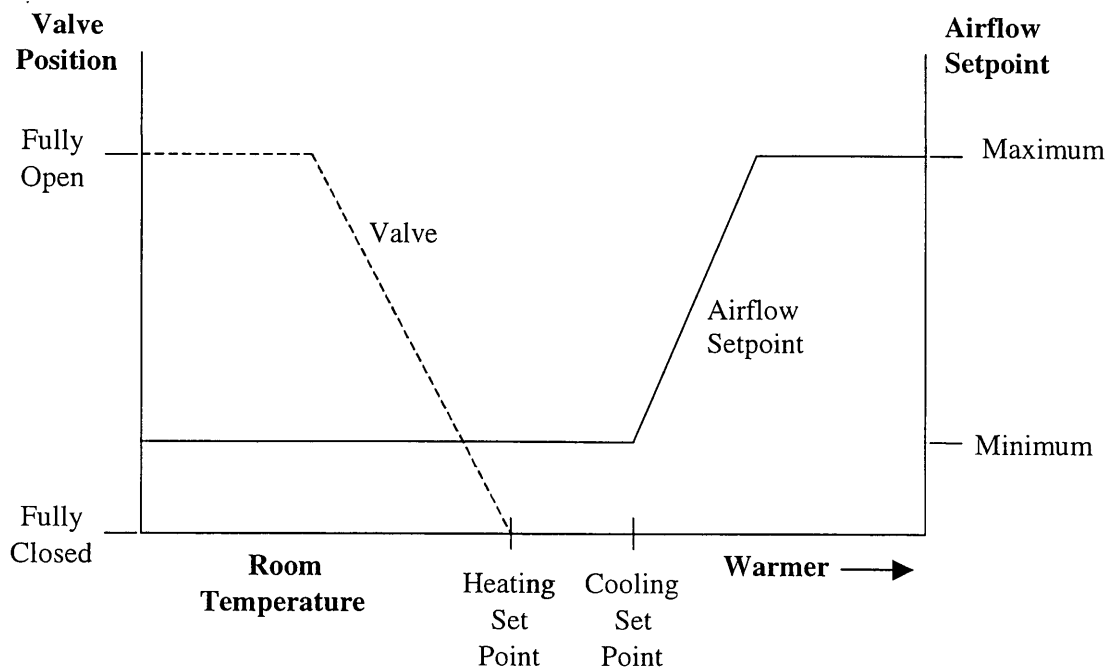

Figure 2.5: Damper and valve control sequence as a function of room temperature for a single duct pressure-independent VAV box with hydronic reheat.

2.2.4 CUSUM Applied to VAV Box Diagnostics

The previous section described one particular VAV box control strategy. However, a wide variety of control strategies are employed by controller manufacturers, most of which use a cascaded control loop to maintain the zone temperature and zone airflow rate at setpoint values. In order to make VPACC independent of the control strategy used in a particular controller/VAV box application, four generic errors were identified: the airflow rate error, the absolute value of the airflow rate error, the temperature error, and the reheat coil differential temperature error. As long as the VAV box controller has an airflow setpoint, as well as heating and cooling temperature setpoints, VPACC will function independently of the control strategy used. Common mechanical and control faults will result in a deviation of one or more of these errors from its value during normal operation, which can be detected by a CUSUM chart.

The airflow rate error, Q_{error} , is defined as

$$Q_{error} = Q_{actual} - Q_{setpoint} \quad (3)$$

where

- Q_{actual} = measured airflow rate
- $Q_{setpoint}$ = airflow rate set point.

The CUSUMs of this error, S_Q and T_Q , are effective for detecting damper faults and differential pressure sensor faults associated with airflow measurement.

The absolute value of the airflow rate error, $|Q_{error}|$, is defined as

$$|Q_{error}| = |Q_{actual} - Q_{setpoint}| \quad (4)$$

Only one CUSUM value, $S_{|Q|}$, is defined for this error since the error is never negative. $S_{|Q|}$ is effective for detecting unstable damper control faults.

The temperature error, T_{error} , is defined as

$$T_{error} = T_{zone} - CSP \quad : \text{ If } T_{zone} > CSP \quad (5a)$$

$$T_{error} = 0 \quad : \text{ If } HSP \leq T_{zone} \leq CSP \quad (5b)$$

$$T_{error} = T_{zone} - HSP \quad : \text{ If } T_{zone} < HSP \quad (5c)$$

where

T_{zone} = zone temperature

CSP = cooling set point

HSP = heating set point.

The CUSUMs of the temperature error, S_T and T_T , are effective for detecting damper faults, valve faults, and temperature sensor faults. The specific definition of temperature error used in this report is based on the control sequence described above. Various other commonly used control sequences may require changes to the definitions of heating setpoint, cooling setpoint, and temperature error.

The reheat coil differential temperature error, ΔT_{error} , is defined as

$$\Delta T_{error} = T_{discharge} - T_{entering} \quad : \text{ If } u_{hc} = 0 \quad (6a)$$

$$\Delta T_{error} = 0 \quad : \text{ If } u_{hc} \neq 0 \quad (6b)$$

where

$T_{discharge}$ = discharge air temperature (the temperature of the air leaving the reheat coil)

$T_{entering}$ = entering air temperature (the temperature of the air entering the reheat coil)

u_{hc} = control signal to the reheat coil valve.

The positive CUSUM of the reheat coil differential temperature error, $S_{\Delta T}$, is effective for detecting a leaking reheat coil valve fault. The negative CUSUM, $T_{\Delta T}$, is effective for detecting temperature sensor faults. The leaking valve fault highlights the advantages of automated FDD. Without VPACC, the local controller may be capable of masking this fault by increasing the airflow rate into the space. In this scenario there will be no “too hot” or “too cold” complaints, so a significant energy penalty may be accrued.

The errors and CUSUMs are only calculated during occupied periods. During unoccupied periods, the errors are not computed, and the CUSUMs are reset to zero. The first hour of the occupied period is treated the same as the unoccupied period, to allow steady state conditions to develop.

2.2.5 Point requirements

Most of the points required by VPACC are already available in the local VAV box controller: room temperature, cooling setpoint, heating setpoint, airflow rate setpoint, actual airflow rate, and occupancy status. Entering air temperature is typically not available, so supply air temperature (available over the control network from the AHU controller) could be used. Many VAV boxes are equipped with a discharge air temperature sensor, which VPACC needs in order to calculate the reheat coil differential temperature error. If a discharge air temperature sensor is not available, a simplified version of VPACC could be used, implementing the airflow rate error and the temperature error only.

2.2.6 Parameters

For each process error to which CUSUM analysis is to be applied, there is a set of parameters that must be known and/or specified. These are the expected value of the process error (\hat{x}), the process error standard deviation ($\hat{\sigma}$), the slack parameter (k), and the alarm limits for the S and T CUSUMs (h_S and h_T). For the purposes of this study, the expected value and standard deviation of the process error were determined by analysis of a short period of fault-free operation from a particular data source. CUSUM analysis was performed for each error using an expected value and standard deviation representative of the VAV boxes from each site. These parameters will be referred to as the VPACC statistical parameters throughout the remainder of this paper. The slack parameter $k = 3$ and alarm limits $h_S = h_T = 900$ are the same for all data sources. The values for h_S , h_T , and k were determined heuristically based on results of previous work [1]. To exceed the alarm limit value using one min data, an error that is five standard deviations from the mean would have to persist for 7.5 hours. When a CUSUM does exceed the alarm limit, it is reset to zero and the calculations resume. Each CUSUM is also reset to zero during unoccupied periods (and during the first hour of occupancy, to allow steady state conditions to develop). Thus, the severity of a fault can be established from the number of alarms over a period of time.

2.2.7 Special Cases

2.2.7.1 No Discharge Air Temperature Sensor

Many VAV boxes are equipped with a discharge air temperature sensor, which VPACC needs to calculate the reheat coil differential temperature error. If a discharge air temperature sensor is not available, a simplified version of VPACC could be used, implementing the airflow rate error, the absolute value of the airflow rate error, and the temperature error only. In this case, a leaking reheat coil valve (or, in the case of electric reheat, staged reheat enabled “on” in the cooling mode) would not be detected unless it was so extreme that the VAV box was unable to maintain the zone temperature at the set point, thereby causing alarms due to excessive values of S_T .

2.2.7.2 Pressure Dependent

In some VAV boxes, the damper is controlled directly in response to zone temperature without an intermediate determination of an airflow setpoint. Q_{error} and $|Q_{error}|$ do not exist for a pressure dependent VAV box. In this case, a stuck damper may go undetected. In the case where the zone is overcooled, the reheat coil valve will open (or staged reheat will be enabled “on” if electric reheat is employed) and compensate for the fault, masking its existence. In the case where the zone is undercooled, the rising zone temperature may create alarms due to excessive values of S_T .

2.2.7.3 No Reheat

Some VAV boxes do not have reheat capabilities. Others do not have reheat available part of the year because a two pipe hydronic system is being used for chilled water at that time. Since the VAV box cannot take any control action to increase zone temperature, a negative temperature error does not necessarily indicate a fault. In this situation, only the S_T CUSUM will be calculated for T_{error} .

2.2.7.4 Dual Duct

In a dual duct VAV box, there is no reheat coil (and no electric reheat). Instead there are two air inlets, namely, a cold deck and a hot deck. Each air inlet has a damper and differential pressure sensor. For this arrangement, two airflow errors ($Q_{error,hot}$ and $Q_{error,cold}$) and two absolute value airflow errors ($|Q_{error,hot}|$ and $|Q_{error,cold}|$) will be calculated. No ΔT_{error} will be calculated as there is no reheat capability.

3 Testing Environment

Two different testing environments were used to evaluate the embedded FDD tools: the NIST Virtual Cybernetic Building Testbed (VCBT) and the Iowa Energy Center Energy Resource Station (ERS).

3.1 VCBT

The VCBT is a simulation-emulation environment that combines simulations of a building and its HVAC system with actual commercial HVAC equipment controllers. It provides a way to conduct tests under a wide variety of carefully controlled conditions and to compare the results of several different commercial products. Emulation provides a test environment that is closer to a real building because it uses real building controllers but, like simulation, it also provides carefully controlled and reproducible conditions. Because emulation is done in real time it takes much longer than simulation, making it more difficult to test a broad range of faults and conditions in a limited time. Details of the VCBT design and operation are documented in [4].

For this study, the VCBT was configured with one AHU for each of the three floors, designated AHU-A, -B, and -C. AHU-A and -C are VAV systems, each with three VAV boxes. AHU-B is a constant volume system, with three zone reheat coils.

3.1.1 AHU Control Strategies

The control strategies described below reflect the logic that is executed by the AHU controllers.

3.1.1.1 AHU-A Control Strategy

3.1.1.1.1 Fan Control

The supply air fan speed is controlled to maintain the supply air pressure at a fixed set point. The return air fan speed is controlled to maintain a constant difference between the supply and return air flow rates.

3.1.1.1.2 Temperature Control

AHU-A uses a single PI control loop to determine a temperature control signal to maintain the supply air temperature at a fixed set point. Depending on the magnitude of the signal, it is mapped to one of three outputs which control the heating coil, cooling coil, and mixing-box dampers. Additional logical sets the position of the other two outputs appropriately depending on which one is active. For example, if the heating coil valve is active, the cooling coil valve will be fully closed and the mixing box damper will be set to the minimum position (which depends on the occupancy status). The outdoor air and the return air enthalpies are compared to determine whether to enable or disable economizer operation.

3.1.1.2 AHU-B Control Strategy

3.1.1.2.1 Fan Control

AHU-B is a constant volume system, so the supply air fan and return air fan both operate at fixed speeds.

3.1.1.2.2 Temperature Control

AHU-B uses a single PI control loop to determine a temperature control signal to maintain the supply air temperature at a fixed set point. Depending on the magnitude of the signal, it is mapped to one of three outputs which control the heating coil, cooling coil, and mixing-box dampers. Additional logical sets the position of the other two outputs appropriately depending on which one is active. For example, if the heating coil valve is active, the cooling coil valve will be fully closed and the mixing box damper will be set to the minimum position (which depends on the occupancy status). The outdoor air temperature is compared to a fixed changeover temperature to determine whether to enable or disable economizer operation.

3.1.1.3 AHU-C Control Strategy

3.1.1.3.1 Fan Control

The supply air fan speed is controlled to maintain the supply air pressure at a fixed set point. The return air fan speed is controlled to maintain a constant difference between the supply and return air flow rates.

3.1.1.3.2 Temperature Control

AHU-C uses a separate PI control loop for each of three outputs which control the supply air temperature: the heating coil, cooling coil, and mixing-box dampers. The heating coil and cooling coil outputs are controlled to maintain supply air temperature at a fixed set point. The mixing box dampers are controlled by comparing the outside air and the return air enthalpies. If the return air enthalpy is greater than the outdoor air enthalpy, the mixing-box damper control loop maintains mixed air temperature at its set point (also fixed). Interlocks, dead bands, and time delays are incorporated to prevent simultaneous heating, cooling, and economizing.

3.1.2 Embedded APAR

APAR was embedded in the AHU controllers by adding additional logic to their control programs to execute the APAR algorithm. The three AHU controllers are each from a different manufacturer.

The cooling coil valve, mixing box damper, and heating coil valve control signals are evaluated, along with the occupancy status, to determine in which mode the AHU is operating. A binary value (BV) is used to represent the status of each mode. Exponentially weighted moving averages (EWMAs) are computed for these control signals, as well as for supply air temperature, return air temperature, mixed air temperature, outdoor air temperature, supply air temperature setpoint, return air humidity, return air enthalpy, outside air humidity, and outside air enthalpy. EWMAs are used to smooth the variation in the data because, unlike other types of moving averages, no historical data need be stored in the controller's memory - only the current value and EWMA of each measurement need to be stored. The EWMAs are reset when a mode switch occurs. A 60 minute timer starts when the logic recognizes that the AHU is operating in one of the five defined modes of operation, and is reset when the AHU is no longer in that mode. When the timer expires, the rules for that particular mode are evaluated. Each rule is represented by a binary value, set to a value of "on" if the rule is satisfied - indicating a fault, otherwise it is set to a value of "off". Rule 28, regarding excessive mode switches, is a special case, since it is evaluated independently of the modes. To evaluate Rule 28, a counter is incremented every time a mode switch occurs. A timer resets the counter to zero every 60 minutes. If the value of the

counter exceeds the maximum number of mode switches, the binary value representing Rule 28 is set to a value of “on” – indicating a fault, otherwise it is set to a value of “off”.

A stand-alone program, BACnet Data Source (BDS) [4], was installed on a workstation connected to the VCBT control network and configured to trend the raw data (temperatures, valve positions, etc.) as well as intermediate values and results of the APAR algorithm (mode and rule status). The raw data was read once per minute, while the APAR values were read once every five minutes. The EWMA's were not trended, as they could easily be recreated from the raw data and mode status if necessary. For every fault detected by APAR, the raw data was examined to verify that the FDD results matched the conditions.

3.1.3 VCBT Fault Descriptions

3.1.3.1 Supply Air Temperature Sensor Drift

Supply air temperature sensor drift is introduced as a sensor offset for a range of 0.0 °C to ±4.0 °C (0.0 °F to ±7.2 °F), applied linearly over a three week emulation period. If a controller maintains the measured supply air temperature at the set point, a negative sensor offset would result in a decreased actual supply air temperature. A positive sensor offset would result in an increased actual supply air temperature.

3.1.3.2 Return Air Temperature Sensor Drift

Return air temperature sensor drift is introduced as a sensor offset for a range of 0.0 °C to ±4.0 °C (0.0 °F to ±7.2 °F), applied linearly over a three week emulation period. The return air temperature sensor is used to control the economizer operation for AHU-A and -C. A negative sensor drift for the return air temperature with no change to the humidity reading would result in an increased return air enthalpy. A positive sensor drift for the return air temperature with no change to the humidity reading would result in a decreased return air enthalpy. Depending on weather conditions, this fault may cause inappropriate economizer control.

3.1.3.3 Mixed Air Temperature Sensor Drift

Mixed air temperature sensor drift is introduced as a sensor offset for a range of 0.0 °C to ±4.0 °C (0.0 °F to ±7.2 °F), applied linearly over a three week emulation period. If a controller maintains the measured mixed air temperature at the set point, a negative sensor offset would result in a decreased actual mixed air temperature. A positive sensor offset would result in an increased actual mixed air temperature.

3.1.3.4 Outdoor Air Temperature Sensor Drift

Outdoor air temperature sensor drift is introduced as a sensor offset for a range of 0.0 °C to ±4.0 °C (0.0 °F to ±7.2 °F), applied linearly over a three week emulation period. The outdoor air temperature sensor is used to control the economizer operation for AHU-A, -B, and -C. A negative sensor drift for the outdoor air temperature with no change to the humidity reading would result in an increased outdoor air enthalpy. A positive sensor drift for the outdoor air temperature with no change to the humidity reading would result in a decreased outdoor air enthalpy. Depending on weather conditions, this fault may cause inappropriate economizer control.

3.1.3.5 Outdoor Air Damper Fault

The outdoor air damper faults are introduced by overriding the normal control signal to the damper with a control signal to force the motor-driven actuator to the specified position, causing the damper to stay at that position throughout the emulation period. While emulating the outdoor air damper fault, the recirculation air and the exhaust air dampers follow normal operation. The economizer may not operate correctly because of the fault, depending on the outdoor and indoor conditions.

3.1.3.6 Recirculation Air Damper Fault

The recirculation air damper faults are introduced by overriding the normal control signal to the damper with a control signal to force the motor-driven actuator to the specified position, causing the damper to stay at that position throughout the emulation period. While emulating the recirculation air damper fault, the outdoor air and the exhaust air dampers follow normal operation. The economizer may not operate correctly because of the fault, depending on the outdoor and indoor conditions.

3.1.3.7 Economizer Control Logic Fault

This fault is introduced by reversing the logic used to decide whether the economizer or the minimum ventilation operation should become active. The fan speed and temperature control loops operate normally.

3.1.3.8 Temperature Sensor Failure

A supply air, return air, mixed air, or outdoor air temperature sensor fault is introduced by disconnecting the leads to the appropriate sensor terminals on the AHU controller.

3.2 ERS

The ERS is a laboratory facility for HVAC research that has two test VAV air-handling systems, each serving four test zones. The HVAC equipment and controllers are typical of that found in commercial buildings. The VAV boxes are single duct throttling units having both hydronic and electric reheat capabilities. They were operated with hydronic reheat to produce the data for this study. The VAV boxes are well instrumented; many more points are monitored than would commonly be available in a commercial building. Details of the facility are provided in [5].

3.2.1 Embedded VPACC

VPACC was embedded in four VAV box controllers by adding additional logic to their control programs to carry out the VPACC algorithm. It was necessary to limit the testing to a single manufacturer's controllers to enable communication between the VAV box controllers and the balance of the control system.

The airflow error, absolute value of the airflow error, temperature error, and reheat coil ΔT error are calculated continuously. A sixty minute timer is started when the occupancy status goes from unoccupied to occupied. When the timer expires, the CUSUM S and T cumulative sums (each sum is represented by an analog value) are evaluated once per minute for each of the

errors, with the following exceptions: for the $|Q_{error}|$ the S cumulative sum only is calculated, and the ΔT_{error} S and T cumulative sums are set to zero if the reheat coil control valve is not fully closed. There is an alarm status, represented by a binary value, for each cumulative sum. If the sum is greater than the alarm limit (h), the corresponding alarm status is set to a value of “on”. If the sum then falls below h , the alarm status is set to “off”. There is also an overall VPACC alarm status, which is set to a value of “on” if any of the cumulative sum alarm statuses are “on”. If the cumulative sum alarm statuses are all “off” then the VPACC alarm status is set to “off”.

The operator interface software written by the manufacturer of the VAV box controllers was installed on a workstation connected to the ERS control network and configured to trend the raw data (temperatures, humidities, etc.) as well as intermediate values and results of the VPACC algorithm (S and T cumulative sum values and alarm statuses). The raw data and VPACC values were read once per minute. For every fault detected by VPACC, the raw data was examined to verify that the FDD results matched the conditions.

3.2.2 ERS Fault Descriptions

3.2.2.1 Damper Stuck Partially Open

This fault is introduced by overriding the VAV box damper actuator to a fixed position that produces a flow rate between the minimum and maximum specified for that box. If the zone airflow is lower than necessary, the zone temperature will drift above the cooling set point. If the zone airflow is higher than necessary, the controller will transition to the heating mode and the reheat coil valve will modulate to maintain the zone temperature at the set point.

3.2.2.2 Hydronic Reheat Coil Valve Stuck Partially Open

This fault is introduced by overriding the VAV box hydronic reheat coil valve actuator position to allow a hot water flow rate of approximately 2 % to 10 % of the maximum flow through the coil. Depending on the zone conditions and the severity of the fault, the stuck reheat valve either creates an additional cooling load that the AHU must try to remove, or it prevents the valve from modulating to provide additional heating energy to the zone. In the first case, the controller increases the airflow rate to the zone in an attempt to compensate for the fault. If the fault is severe, the zone temperature will gradually increase beyond the zone cooling set point. In the second case, the zone temperature will tend to gradually decrease below the zone heating set point.

3.2.2.3 Failed Differential Pressure Sensor

This fault is introduced by disconnecting both tubing leads to the differential pressure sensor. The fault causes the VAV box damper to go to the full open position because the flow sensor indicates an airflow rate of zero and the control loop will attempt to correct for this condition.

3.2.2.4 Unstable Flow Control

The fault is implemented by altering a component of the control logic that limits the rate of increase and decrease of the airflow control output. The fault causes the VAV box damper to oscillate, thereby producing airflow rates that oscillate about the set point.

4 Results

4.1 VCBT

The VCBT emulated an HVAC system operating during heating season (using February weather data), swing season (using October weather data), and cooling season (using July weather data). A variety of sensor, actuator, and control logic faults, along with fault free conditions, were imposed. The results of the FDD calculations performed by the AHU controllers are shown in Table 4.1. A false positive is a false alarm. A false negative is an undetected fault.

Table 4.1 VCBT Embedded FDD Result Summary

System	Fault	Season	Correct	False Positive	False Negative
AHU-A	Supply Air Temperature Sensor Drift	Heating	X		
	Recirculation Air Damper Leakage	Swing	X		
	Outdoor Air Temperature Sensor Failure	Swing	X		
	Mixed Air Temperature Sensor Drift	Swing	X		
	Supply Air Temperature Sensor Failure	Cooling	X		
	Recirculation Air Damper Stuck Closed	Cooling	X		
AHU-B	Fault Free	Heating	X		
	Fault Free	Swing	X		
	Return Air Temperature Sensor Drift	Swing			X
	Fault Free	Swing	X		
	Economizer Control Logic Fault	Cooling	X		
	Economizer Control Logic Fault	Cooling	X		
AHU-C	Mixed Air Temperature Sensor Failure	Heating	X		
	Return Air Temperature Sensor Drift	Swing			X
	Outdoor Air Damper Stuck at Minimum	Swing			X
	Recirculation Air Damper Leakage	Swing	X		
	Return Air Temperature Sensor Drift	Cooling	X		
	Mixed Air Temperature Sensor Drift	Cooling	X		

The AHU controller determined the correct fault status in 15 of the 18 cases. There were zero false positives and three false negatives. Two of the false negatives were return air temperature sensor drift faults in AHU-B and AHU-C, both in swing season. The swing season weather conditions resulted in the AHUs operating in Modes 2 (cooling with outdoor air) and 3 (mechanical cooling with 100 % outdoor air) most of the time. However, the return air temperature sensor drift fault was also instigated in AHU-C in cooling season, when the AHUs operated mostly in mode 4 (mechanical cooling with minimum outdoor air). This time, the return air temperature sensor drift was detected. This shows that some faults can be detected under certain conditions, but not others. The other false negative was an outdoor air damper in AHU-C stuck at the minimum position during swing season. In this case, the AHU controller

can still adjust the ratio of return to outdoor air by modulating the recirculation and exhaust dampers. This is an example of a fault that is masked by the control system.

Several examples are presented to illustrate the details of the APAR algorithm.

4.1.1 Outdoor Air Temperature Sensor Failure

This fault was introduced by disconnecting the leads to the terminals on the AHU-A controller on which the outdoor air temperature sensor was connected. This is a 0 – 10 VDC analog input calibrated to a range of $-6\text{ }^{\circ}\text{C} - 49\text{ }^{\circ}\text{C}$ ($20\text{ }^{\circ}\text{F} - 120\text{ }^{\circ}\text{F}$), so with the leads disconnected, the controller reads 0 VDC, which is scaled to an outdoor air temperature of $-6\text{ }^{\circ}\text{C}$ ($20\text{ }^{\circ}\text{F}$).

Swing season is characterized by substantial variation in outdoor air temperature and humidity. Modes 2, 3, and 4 (cooling with outdoor air, mechanical cooling with 100% outdoor air, and mechanical cooling with minimum outdoor air, respectively) are all encountered during a fault free three week swing season emulation. When the fault is introduced, the controller reads an outdoor air temperature of $-6\text{ }^{\circ}\text{C}$ ($20\text{ }^{\circ}\text{F}$). The logic in the controller calculates outdoor air enthalpy based on outdoor air temperature and outdoor air humidity, so the erroneously low reading of outdoor air temperature will result in an erroneously low calculated value of outdoor air enthalpy. The AHU-A controller compares the calculated value of outdoor air enthalpy to return air enthalpy (calculated in a similar fashion based on return air temperature and return air humidity) and enables economizer operation if the outdoor air enthalpy is less than the return air enthalpy. The erroneously low calculated value of outdoor air enthalpy will cause the controller to enable economizer operation, even if such operation is inappropriate.

Figures 4.1 and 4.2 show data from AHU-A from the occupied portion of one day during the emulation of this fault. Since the actual outdoor air temperature is greater than the supply air temperature setpoint, the mixing box dampers (green, figure 4.1) will saturate at the 100 % outdoor air position, and the AHU controller will modulate the cooling coil valve (blue, figure 4.1) to maintain the supply air temperature at its setpoint. The heating coil valve (red, figure 4.1) is closed. Based on this combination of control signals, APAR determines the system to be operating in Mode 3 (mechanical cooling with 100 % outdoor air) and evaluates the applicable rule set. One of the rules in the set for Mode 3 is Rule 8, which states that if the outdoor air temperature (green, figure 4.2) is less than the supply air temperature setpoint (not shown, constant $12.8\text{ }^{\circ}\text{C}$ ($55\text{ }^{\circ}\text{F}$)) minus the temperature rise across the supply fan ($1.1\text{ }^{\circ}\text{C}$ ($2\text{ }^{\circ}\text{F}$)) by more than a certain threshold ($1.7\text{ }^{\circ}\text{C}$ ($3\text{ }^{\circ}\text{F}$)), then a fault has been detected. Another rule in the set for Mode 3 is Rule 10, which states that if the absolute value of the difference between outdoor air temperature and mixed air temperature (purple, figure 4.2) is greater than a certain threshold ($1.7\text{ }^{\circ}\text{C}$ ($3\text{ }^{\circ}\text{F}$)), then a fault has been detected. On the day shown in figures 4.1 and 4.2, Rules 8 and 10 are satisfied, indicating that this fault has been successfully detected. The fault status data collected from the AHU-A controller indicates that this fault was detected on this particular day of operation.

4.1.2 Mixed Air Temperature Sensor Drift

This fault is introduced as a sensor offset beginning at $0\text{ }^{\circ}\text{C}$ and increasing linearly over a three week emulation period to $+4\text{ }^{\circ}\text{C}$. The positive sensor drift means that the measured mixed air temperature is greater than the actual mixed air temperature by the amount of the offset.

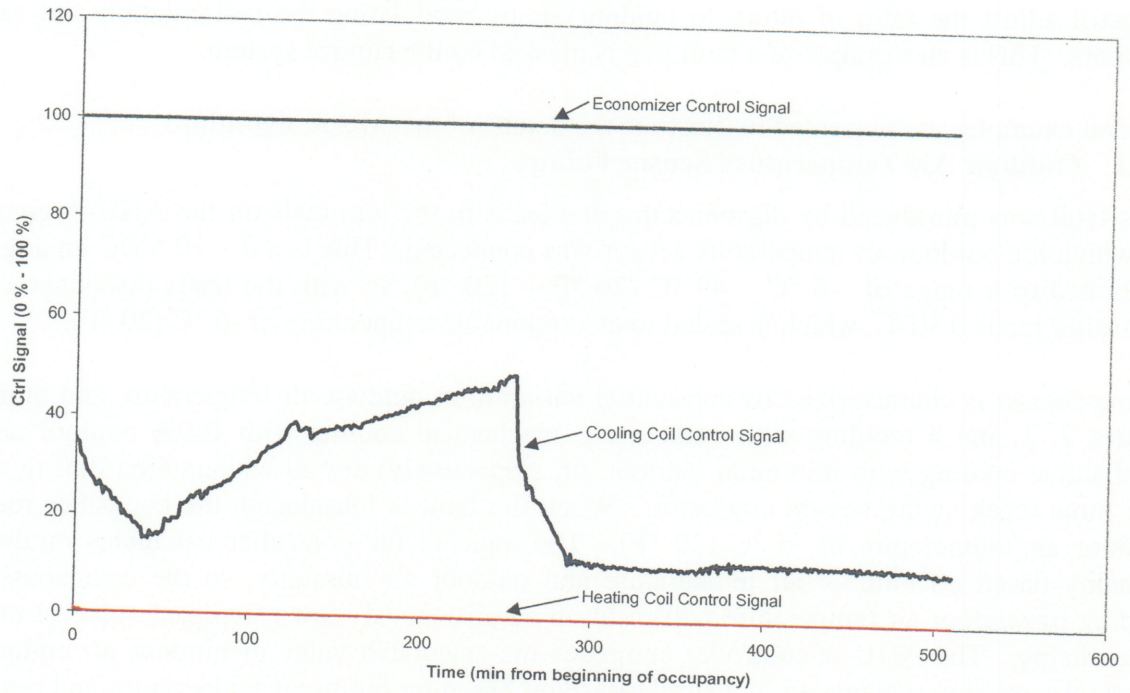

Figure 4.1 VCBT AHU-A Outdoor Air Temperature Sensor Failure – Control Signals

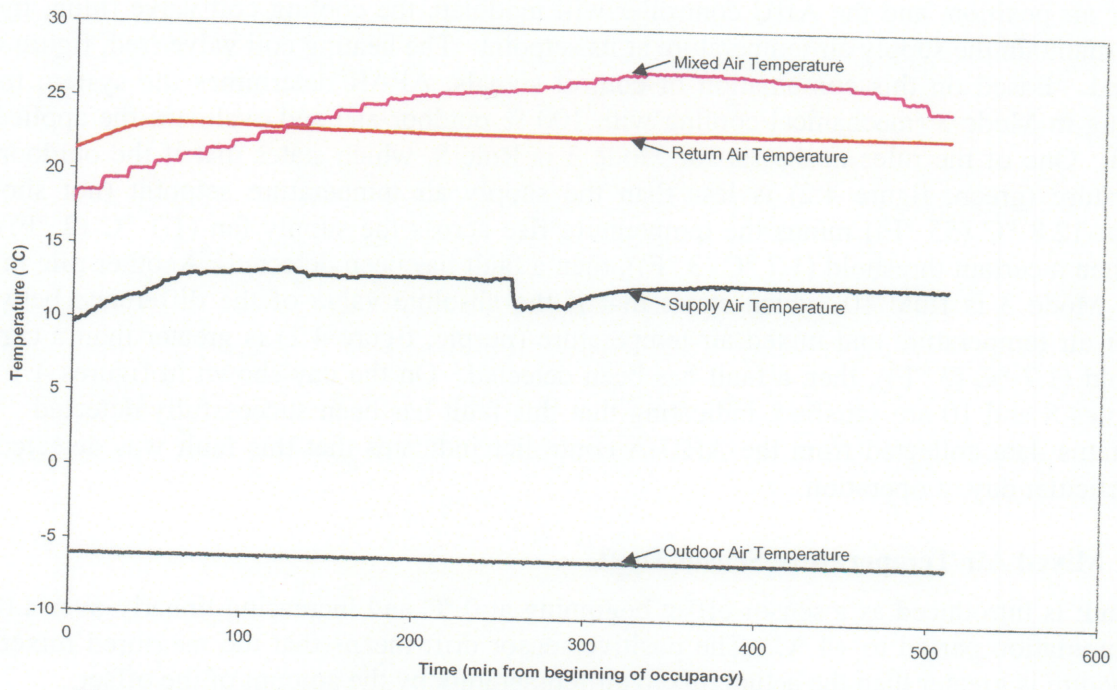

Figure 4.2 VCBT AHU-A Outdoor Air Temperature Sensor Failure - Process Temperatures

Figures 4.3 and 4.4 show AHU-C data from the occupied portion of one day during the emulation of this fault. On this particular day, the outdoor air temperature (green, figure 4.4) and humidity (not shown) are high enough to prohibit economizing, as they typically are during cooling season, so the mixing box dampers (green, figure 4.3) are aligned to bring in the minimum amount of outdoor air needed for ventilation. The AHU controller modulates the cooling coil valve (blue, figure 4.3) to maintain the supply air temperature (light blue, figure 4.4) at its setpoint (dark blue, figure 4.4). The heating coil valve (red, figure 4.3) is closed.

Based on this combination of control signals, APAR determines the system to be operating in Mode 4 (mechanical cooling with minimum outdoor air) and evaluates the applicable rule set. One of the rules in the set for Mode 4 is Rule 26, which states that the mixed air temperature (brown, figure 4.4) should be between the return air temperature (red, figure 4.4) and outdoor air temperature (green, figure 4.4). If the mixed air temperature is below the lesser of the return air or outdoor air temperature, or above the greater of the return air or outdoor air temperature, by a certain threshold (1.7 °C (3 °F)), then a fault has been detected. The actual mixed air temperature is, in fact, between the return air and outdoor air temperature, since it is the result of blending the outdoor air and return air streams. However, due to the sensor drift, the measured mixed air temperature is below the return air temperature (the lesser of the return air and outdoor air temperature) by approximately 3 °C (5.4 °F). Rule 26 is satisfied, indicating that this fault has been successfully detected. The fault status data collected from the AHU-C controller indicates that this fault was detected on this particular day of operation.

4.1.3 Recirculation Damper Stuck Closed

When this fault is introduced, the AHU controller calculates the desired position of the recirculation damper and sets the damper control signal normally. Within the emulation, the damper position is set to the fully closed position, corresponding to 100 % outdoor air throughout the emulation period. During emulation of this fault, the outdoor air and exhaust air dampers follow normal operation.

Figures 4.5 and 4.6 show data from AHU-A from the occupied portion of one day during the emulation of this fault. On this particular day, the outdoor air temperature (green, figure 4.6) and humidity (not shown) are high enough to prohibit economizing, as they typically are during cooling season, so the mixing box dampers (green, figure 4.5) are commanded to bring in the minimum amount of outdoor air needed for ventilation. However, the recirculation damper is stuck closed, so the actual outdoor air flow rate is greater than the minimum required. The qualitative effect of the stuck recirculation damper can be seen by comparing the mixed air temperature (brown, figure 4.6) to the return (red, figure 4.6) and outdoor air temperatures (green, figure 4.6). If the dampers were aligned correctly, the mixed air temperature should be very close to the return air temperature, but it is actually much closer to the outdoor air temperature, due to the excessive amount of outdoor air being drawn into the AHU. The AHU controller modulates the cooling coil valve (blue, figure 4.5) to maintain the supply air temperature (light blue, figure 4.6) at its setpoint (dark blue, figure 4.6). The heating coil valve (red, figure 4.5) is closed.

Based on this combination of control signals, APAR determines the system to be operating in Mode 4 (mechanical cooling with minimum outdoor air) and evaluates the applicable rule set.

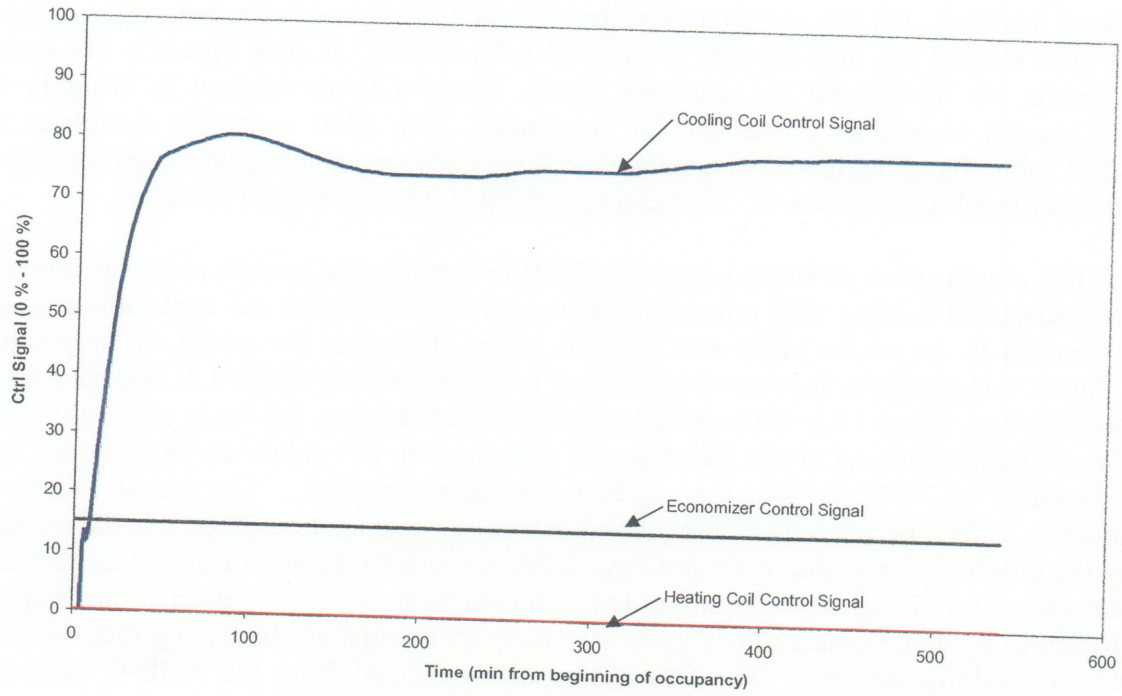

Figure 4.3 VCBT AHU-C Mixed Air Temperature Sensor Drift - Control Signals

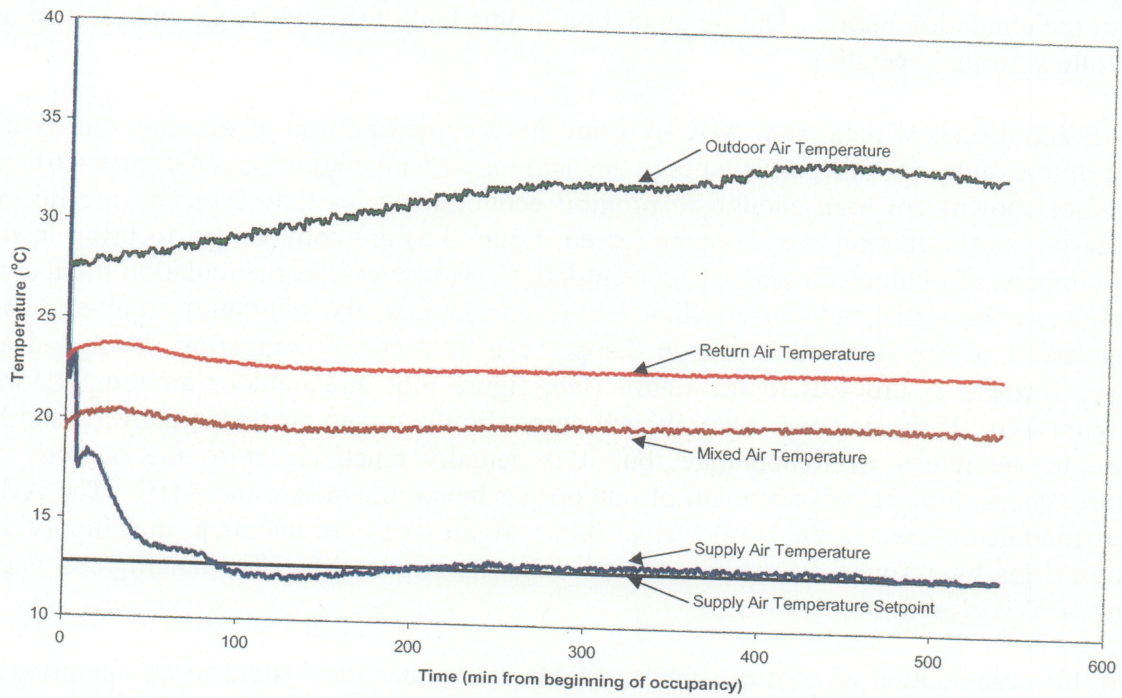

Figure 4.4 VCBT AHU-C Mixed Air Temperature Sensor Drift - Process Temperatures

One of the rules in the set for Mode 4 is Rule 18, which first checks whether there is enough of a difference, 5.6 °C (10 °F), between the return and outdoor air temperatures in order to proceed. In the case illustrated by figures 4.5 and 4.6, the difference becomes sufficient from approximately 250 minutes after the beginning of the occupied period until the end of the occupied period. If the difference is sufficient, the next step in the evaluation of Rule 18 is to calculate the fraction of outdoor air by dividing the difference between mixed air and return air temperature by the difference between outdoor air and return air temperature. If the calculated outdoor air fraction varies by more than a specified threshold, 0.30, from the minimum amount of outdoor air needed for ventilation (in this case, 0.15), Rule 18 is satisfied, indicating that this fault has been detected. The fault status data collected from the AHU-A controller indicates that this fault was detected on this particular day of operation.

4.1.4 Economizer Control Logic Fault

When this fault is introduced, the logic used to select economizer or minimum ventilation operation is reversed. The AHU-B controller compares the outdoor air temperature to a fixed changeover temperature, 22.2 °C (72 °F), to determine whether to enable or disable economizer operation. Normally, economizer operation is disabled if the outdoor air temperature is greater than the changeover temperature and enabled if the outdoor air temperature is less than the changeover temperature, subject to a deadband of 1.1 °C (2.0 °F). When the economizer fault is implemented, this relationship is reversed: economizer operation is enabled if the outdoor air temperature is greater than the changeover temperature and disabled if the outdoor air temperature is less than the changeover temperature, still subject to the specified deadband.

Figures 4.7 and 4.8 show data from AHU-B from the occupied portion of one day during the emulation of this fault. On this particular day, the outdoor air temperature (green, figure 4.8) ranges from 26 °C (79 °F) to 33 °C (91 °F), which is greater than the changeover temperature (orange, figure 4.8) by more than the deadband as is typically the case for cooling season. If AHU-B was operating without any faults, these conditions would cause the AHU controller to disable the economizer and align the mixing box dampers to bring in the minimum amount of outdoor air needed for ventilation. Due to the control logic fault, the mixing box dampers (green, figure 4.7) are actually aligned to bring in 100 % outdoor air. Qualitatively, this can be seen by comparing the mixed air temperature (brown, figure 4.8) to the return (red, figure 4.8) and outdoor air temperatures (green, figure 4.8). If the dampers were aligned for minimum outdoor air, the mixed air temperature would be very close to the return air temperature, but actually the mixed air temperature is nearly identical to the outdoor air temperature, because the fault in the AHU control logic has positioned the dampers to bring in 100 % outdoor air. The AHU controller modulates the cooling coil valve (blue, figure 4.7) to maintain the supply air temperature (light blue, figure 4.8) at its setpoint (dark blue, figure 4.8). The heating coil valve (red, figure 4.7) is closed.

Based on this combination of control signals, APAR determines the system to be operating in Mode 3 (mechanical cooling with 100 % outdoor air) and evaluates the applicable rule set. One of the rules in the set for Mode 3 is Rule 9, which, as modified to match the absolute temperature-based economizer control strategy employed for AHU-B, states that if the outdoor air temperature (green, figure 4.8) is greater than the changeover temperature (orange, figure

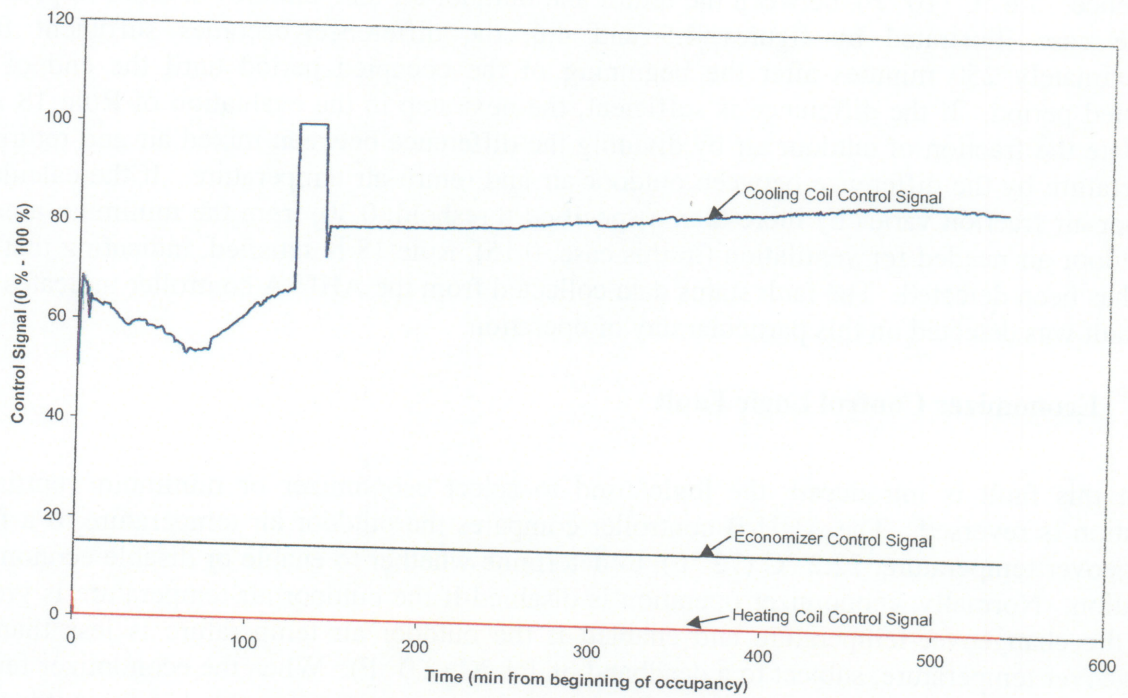

Figure 4.5 VCBT AHU-A Recirculation Damper Stuck Closed – Control Signals

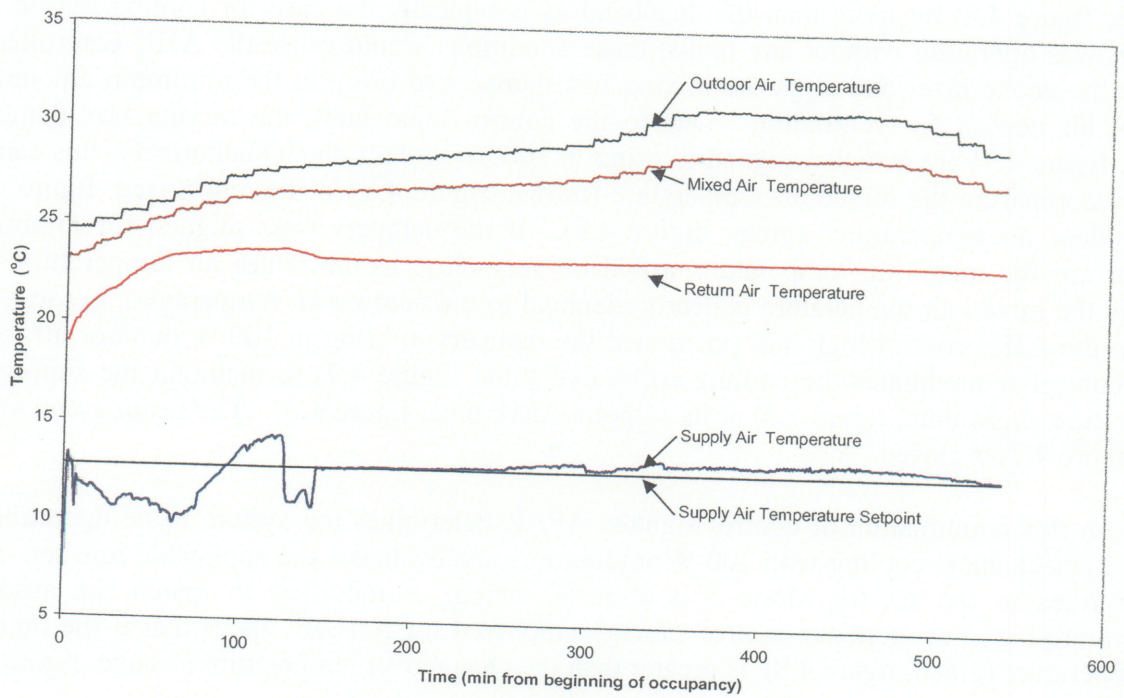

Figure 4.6 VCBT AHU-A Recirculation Damper Stuck Closed – Process Temperatures

4.8) plus the deadband (1.1 °C (2.0 °F)) by more than a specified threshold (1.7 °C (3 °F)), a fault has been detected. The fault status data collected from the AHU-B controller indicates that this fault was detected on this particular day of operation.

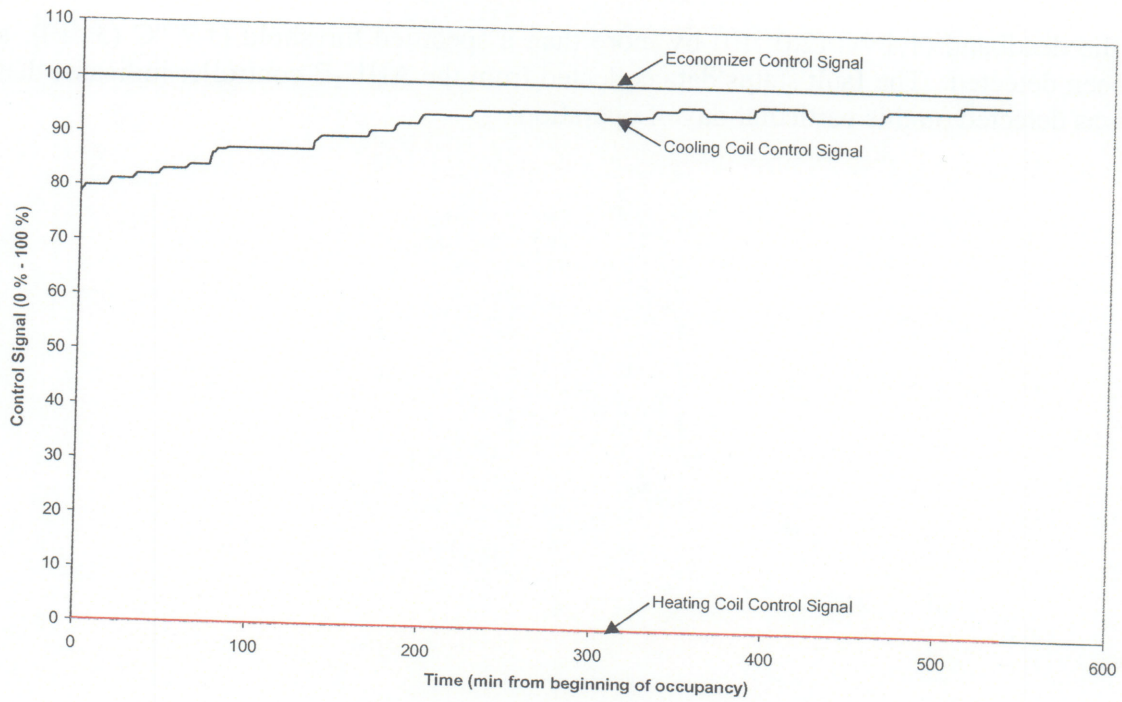

Figure 4.7 VCBT AHU-B Economizer Control Logic Fault – Control Signals

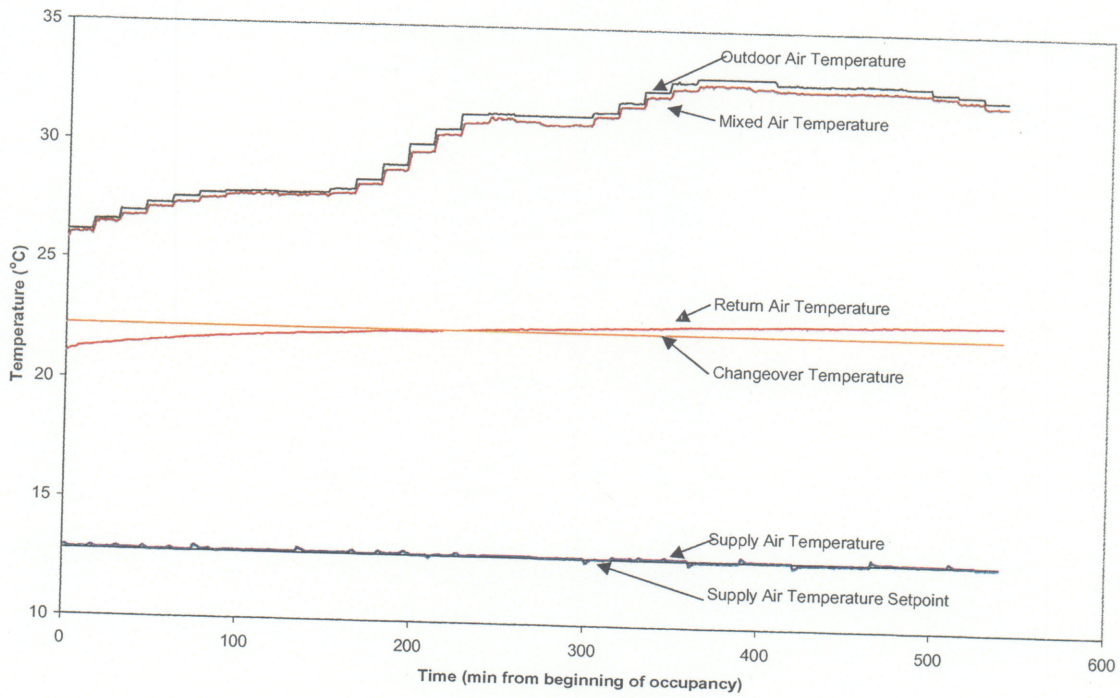

Figure 4.8 VCBT AHU-B Economizer Control Logic Fault – Process Temperatures

4.2 ERS

The supply air temperature from the AHU controller was made available to each of the VAV box controllers via the control network and was used as the entering air temperature in the calculation of reheat coil differential temperature error. To establish the VPACC statistical parameters, three days of normal operation data were collected at one-minute sampling intervals from four VAV box controllers during the cooling season. The data were processed off-line and yielded the parameters in Table 4.2. The mean calculated for each of the errors was used for \hat{x} in the VPACC algorithm, and the standard deviation was used for $\hat{\sigma}$. During testing of various fault conditions, online inspection of the output from VPACC showed the output to be consistent with what was expected. That is, the dominant CUSUM value (or values) for each data set was appropriate for the implemented fault.

Table 4.2 VPACC statistical parameters for the ERS data sets

Error	Mean	Standard Deviation
Q_{error}	$3.30 \times 10^{-3} \text{ m}^3/\text{s}$ (7.00 CFM)	$1.32 \times 10^{-2} \text{ m}^3/\text{s}$ (28.0 CFM)
T_{error}	0.59 °C (1.07 °F)	0.36 °C (0.65 °F)
ΔT_{error}	1.11 °C (2.00 °F)	0.34 °C (0.62 °F)

Results obtained for this data set are shown in Table 4.3. Twenty-seven days of normal operation data were processed with VPACC with no false alarms. The reheat coil valve stuck partially open fault was implemented for four days with different severities. Significant differences between the entering and discharge air temperatures produced 17 alarms of $S_{\Delta T}$. The failed differential pressure sensor produced large negative airflow errors, leading to 9 alarms of T_Q and $S_{|Q|}$. Similarly, the stuck open damper fault produced large airflow errors, the signs of which were determined by the loads on the zone.

The unstable airflow fault was implemented for four days with different severities and produced 6 alarms of $S_{|Q|}$. There was one day of testing that did not produce any alarms because the fault was not severe enough. Figure 4.9 shows the airflow error for one day of testing when the fault was more severe. On this particular day, the standard deviation of Q_{error} was $0.11 \text{ m}^3/\text{s}$ (233 CFM), which is more than eight times the standard deviation of the data for normal operation. VPACC output is shown in Figure 4.10. The fault is apparent from $S_{|Q|}$, but not from S_Q or T_Q .

Table 4.3 VPACC results for the ERS data sets

Operation	Number of Days	Number of Alarms						
		S_Q	T_Q	S_T	T_T	$S_{\Delta T}$	$T_{\Delta T}$	$S_{ Q }$
Normal	27	0	0	0	0	0	0	0
Reheat Coil Valve Stuck Partially Open	4	0	0	0	0	17	0	0
Failed DP Sensor	3	0	9	0	0	0	0	9
Unstable Airflow	4	0	0	0	0	0	0	6
Damper Stuck Open	2	4	7	0	0	0	0	11

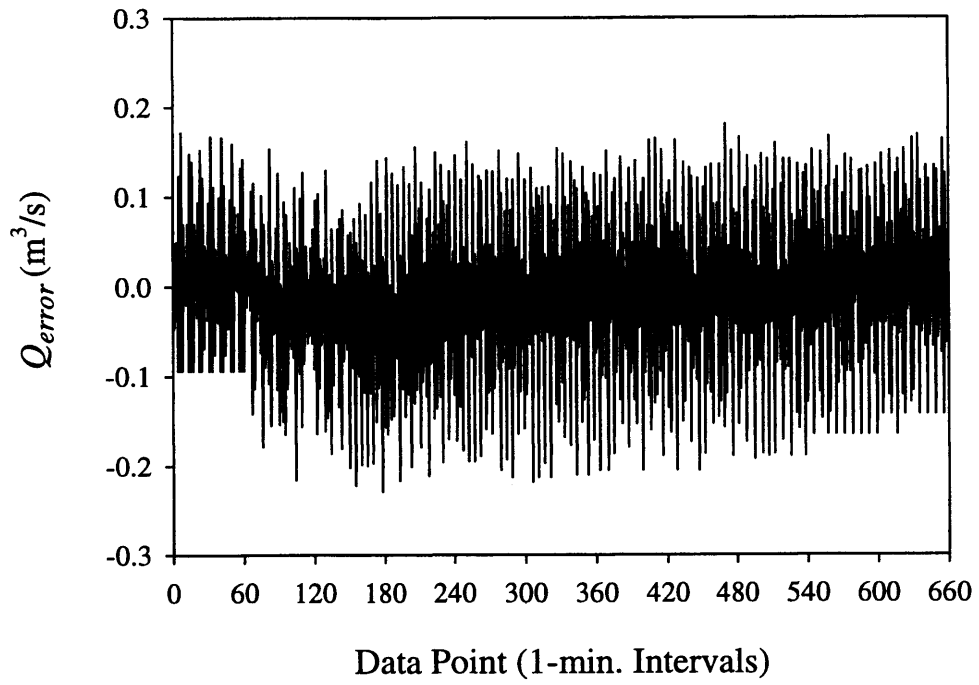

Figure 4.9 ERS data showing the effect of an unstable airflow fault.

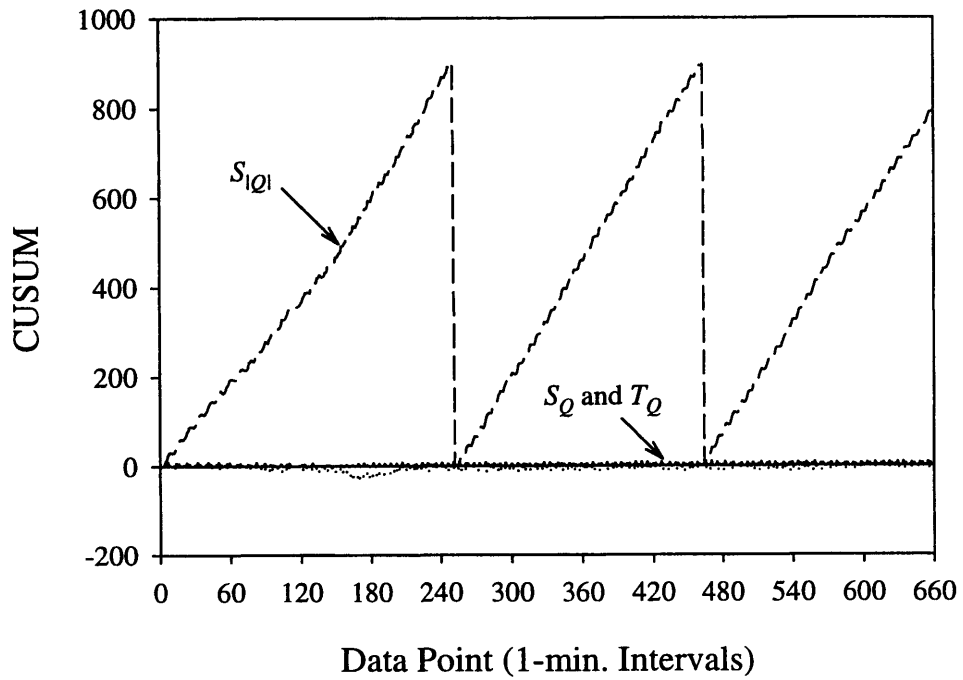

Figure 4.10 VPACC output corresponding to the conditions in Figure 4.9.

5 Summary and Future Work

The purpose of this report is to present the results of an investigation into embedding APAR, a rule based FDD tool for AHUs, and VPACC, a statistical quality control based FDD tool for VAV boxes, into AHU and VAV box controllers, respectively. APAR consists of a set of expert rules, derived from mass and energy balances. Control signals are used to determine the AHU's mode of operation, which identifies the subset of the rules to be evaluated. VPACC uses a small set of process errors, valid for most VAV box control strategies, to measure VAV box performance. CUSUM charts, a statistical quality control tool, are used to evaluate the process errors. Thresholds are determined by statistical analysis of a database of "normal operation" data.

APAR was evaluated in an emulation environment, while VPACC was evaluated in a laboratory environment. Consistent results detecting a variety of common mechanical and control faults show that the FDD tools are both effective at detecting these faults and are suitable for embedding in commercial HVAC equipment controllers.

In a parallel study, the FDD tools were evaluated using trend data from a number of field sites. Follow-on work will require partnering with control system manufacturers to conduct field tests of APAR and VPACC, embedded in their own controller products. NIST's vision of full commercialization of automated fault detection and diagnostics is one in which APAR and VPACC, along with appropriate parameters and thresholds, are packaged within HVAC control products. In order for this vision to become reality, more work is needed in three main areas. First, it is impractical to expect trend data to be evaluated to determine the necessary parameters and thresholds for each site, as was done in this study. Ideally, sets of robust parameters and thresholds that are effective across specified ranges of applications would be identified. Additional field data from a wide variety of systems must be collected in order to determine these robust parameters and thresholds. Also, the current embedded FDD tools are written using generic mathematical functions available in the languages in which the controllers are programmed. Although this approach is suitable for a technology demonstration, built-in APAR and VPACC functions would greatly simplify the task of embedding FDD in a control program.

Finally, more work is needed to develop alternative ways to interpret FDD results and deliver this information to the building operator. The most direct approach is to generate an alarm that the operator must acknowledge whenever a rule is violated (APAR) or a cumulative sum exceeds the alarm limit (VPACC). Refinements to the basic scheme are possible. For example, rather than automatically sending the alarm to the operator, the building control system could highlight, on demand, those devices having experienced the greatest number of alarms in a given period of time. Or, if an automated maintenance management system is used, an alarm could automatically generate an appropriate work order. However, many faults are the result of design or commissioning issues that are beyond the scope of the building maintenance staff. Furthermore, a fault in another piece of equipment, such as an air handling unit, boiler, or chiller, could result in this approach generating a large number of alarms, perhaps overwhelming the operator. A mechanism is needed to resolve multiple conflicting fault reports before reporting them to the operator.

6 References

- [1] Castro, N.S., Schein, J., Park, C., Galler, M.A., Bushby, S.T., and House, J.M., 2002, "Results from Simulation and Laboratory Testing of Air Handling Unit and Variable Air Volume Box Diagnostic Tools", NISTIR 6964.
- [2] House, J.M., Vaezi-Nejad, H., and Whitcomb, J.M., 2001, "An Expert Rule Set for Fault Detection in Air-Handling Units," *ASHRAE Transactions*, Vol. 107, Pt. 1: pp. 858-871.
- [3] Ryan, Thomas P., 2000, *Statistical Methods for Quality Improvement*, 2nd Edition, Wiley and Sons, New York.
- [4] Bushby, S.T., Castro, N.S., Galler, M.A., Park, C., and House, J.M., 2001, "Using the Virtual Cybernetic Building Testbed and FDD Test Shell for FDD Tool Development", NISTIR 6818.
- [5] Price, B.A. and T.F. Smith. 2000. Description of the Iowa Energy Center Energy Resource Station: Facility Update III. Technical Report: ME-TFS-00-001, Department of Mechanical Engineering, The University of Iowa, Iowa City.