



NIST
PUBLICATIONS

REFERENCE

NISTIR 6959

Structural Collapse Fire Tests: Single Story, Ordinary Construction Warehouse

David W. Stroup
Daniel Madrzykowski
William D. Walton
William Twilley



Sponsored in part by
Department of Homeland Security
Federal Emergency Management Agency
United States Fire Administration

QC
100
.U56
no.6959
2003

NIST

National Institute of Standards and Technology
Technology Administration, U.S. Department of Commerce

NISTIR 6959

Structural Collapse Fire Tests: Single Story, Ordinary Construction Warehouse

David W. Stroup
Daniel Madrzykowski
William D. Walton
William Twilley
*Fire Research Division
Building and Fire Research Laboratory
National Institute of Standards and Technology
Gaithersburg, MD 20899-8661*

May 2003



Department of Homeland Security
Tom Ridge, Secretary
Federal Emergency Management Agency
*Michael D. Brown, Under Secretary of Emergency
Preparedness and Response*
United States Fire Administration
R. David Paulison, Administrator

U.S. Department of Commerce
Donald L. Evans, Secretary
Technology Administration
Phillip J. Bond, Under Secretary for Technology
National Institute of Standards and Technology
Arden L. Bement, Jr., Director

Table of Contents

	<u>Page</u>
Abstract.....	1
Introduction.....	1
Experimental Configuration.....	2
Experiments	4
Results.....	5
Conclusions.....	7
Acknowledgements.....	8
References.....	8
Appendix A.....	37
Appendix B.....	51

List of Figures

	<u>Page</u>
Figure 1. Plan view of warehouse showing layout and dimensions (dimensions in meters).....	10
Figure 2. Plan and elevation views showing details of wood trusses supporting the roof of the warehouse.....	11
Figure 3. Elevation view of wall dividing the two areas used for the first test (dimensions in meters).....	12
Figure 4. Elevation view showing front wall of area used for first test (dimensions in meters).....	12
Figure 5. Photograph showing the placement of wood pallets in the front part of the warehouse used for the first test	13
Figure 6. Plan view of warehouse showing locations of measuring instruments and fuel packages (dimensions in meters).....	14
Figure 7. Photograph showing placement of wood pallets and adjacent thermocouple tree in the portion of the warehouse used for the second test.....	15
Figure 8. Photograph of front of warehouse with flames visible through front door at the start of the first test.....	16
Figure 9. Photograph of smoke coming from roof top ventilator during the first test.....	17
Figure 10. Photograph showing smoke coming from roof and front of warehouse as fire is becoming oxygen deficient during the first test.....	18
Figure 11. Photograph showing fire involving significant portion of roof structure with partial collapse beginning	19
Figure 12. Photograph showing the warehouse at the conclusion of the first test with the roof structure over the front half completely gone	20

List of Figures (continued)

	<u>Page</u>
Figure 13.	Photograph of fully involved fuel package through open door after the start of the second test..... 21
Figure 14.	Photograph of smoke coming from open door during second test 22
Figure 15.	Photograph showing flames coming from open door during second test..... 23
Figure 16.	Photograph showing flames through open door and burning roof during the second test..... 24
Figure 17.	Photograph showing partial collapse of the rear and side walls after the second test..... 25
Figure 18.	Graph showing time-temperature history for thermocouples at the ceiling, 0.6 m, 1.2 m, 1.8 m, and 4 m below the ceiling and approximately 4.6 m from the front door during the first test 26
Figure 19.	Graph showing time-temperature history for thermocouples at the ceiling, 0.6 m, 1.2 m, 1.8 m, and 4 m below the ceiling and approximately 13.7 m from the front door during the first test 27
Figure 20.	Graph showing time-temperature history for thermocouples at the ceiling, 0.6 m, 1.5 m, 2.7 m, and 4 m below the ceiling and approximately 22.9 m from the front door during the first test 28
Figure 21.	Graph showing carbon monoxide volume fractions at 25 mm and 0.9 m above the floor and 15 m from the front door during the first test 29
Figure 22.	Graph showing time temperature history for thermocouples at the ceiling, 0.6 m, 1.5 m, 2.7 m, and 4 m below the ceiling and approximately 32 m (4.5 m from the test area dividing wall) from the front door during the second test..... 30
Figure 23.	Graph showing time temperature history for thermocouples at the ceiling, 0.6 m, 1.5 m, 2.7 m, and 4 m below the ceiling and approximately 36.6 m (9.1 m from the test area dividing wall) from the front door during the second test..... 31
Figure 24.	Graph showing carbon monoxide volume fractions at 25 mm and 0.9 m above the floor and 36.6 m from the front door (9.1 m from the test area dividing wall) during the second test..... 32
Figure 25.	Photograph of rear wall showing developing crack in the wall..... 33
Figure 26.	Photograph of roof area showing flames coming from ventilator during first test..... 34
Figure 27.	Photograph of roof top ventilator after it collapsed due to severe heat exposure 35

Structural Collapse Fire Tests: Single Story, Ordinary Construction Warehouse

David W. Stroup, Daniel Madrzykowski,
William D. Walton, and William Twilley

Abstract

Two fire tests were conducted in a warehouse located in Phoenix, Arizona to develop data for evaluation of a methodology for predicting structural collapse. A firewall was constructed to divide the warehouse into two fire compartments. Temperatures were measured as a function of time in three locations during the first test and in two locations during the second test. In addition, the volume fraction of carbon monoxide was measured at selected locations during each test. Stacks of wood pallets were used as the primary fuel source and were ignited using paper and an electric match. Some combustible debris and the building structural elements provided the remainder of the fuel load. Peak temperatures obtained at different elevations ranged from approximately 300 °C (570 °F) to 800 °C (1470 °F). Peak carbon monoxide volume fraction reached 4 % in the first test and 5 % during the second test. The roof of the front half of the structure burned through approximately 18 min after ignition of the fire for the first test. The roof of the back half of the structure burned through about 15 min after the start of the second test.

Key Words:

building collapse; building fires; fire data; fire fighting; large scale fire tests; structural failure; temperature measurements

Introduction

Every year, approximately 100 fire fighters die in the line of duty, and 90,000 to 100,000 are injured [1]. For calendar year 1999, the United States Fire Administration estimated that slightly more than 30 % of the fire fighter fatalities occurring on the fire ground resulted from something other than heart attacks [2]. The categorization of the statistics does not lend itself to easy identification of those deaths that occurred due to structural issues. Examination of specific incidents in 1999 indicates that 18 fire fighters or 16 % died as a result of being trapped in a structure or involved in a collapse [2].

As part of a project funded by the United States Fire Administration, the Building and Fire Research Laboratory (BFRL) at the National Institute of Standards and Technology (NIST) is exploring the feasibility of developing a system for use by fire fighters to predict structural

collapse during fire ground operations. Predicting a potential structural collapse is one of the most challenging tasks facing an incident commander at a fire scene. Usually the lack of information on the construction of the building, fire size, fire location, fire burn time, condition of building, fuel load, etc., makes the task nearly impossible.

The fire department in the City of Phoenix, Arizona is conducting a series of live fire training exercises in various structures in an effort to better educate fire fighters about structural collapse. Some of these structures are being built specifically for the fire tests while others are existing structures that are scheduled for demolition. Each structure is allowed to burn until some portion of the structure collapses. At the invitation of the Phoenix Fire Department, researchers from NIST provided measurement support during the fire tests.

This report presents the results obtained from one set of tests. This test series was conducted to examine several issues related to fire fighter health and safety. The first goal of the tests was to obtain temperature data from a burning structure during a collapse. Second, various techniques and tools are being evaluated for use in predicting structural collapse. Specifically, researchers from Harvey Mudd College, through a NIST-funded grant, measured the building vibrations as means to predict collapse. In addition, the exterior of the building was observed prior to and during collapse to identify any visual indicators of impending collapse. Finally, carbon monoxide volume fractions were measured at selected locations to obtain information regarding the survivability of conditions within the structure prior to collapse.

Experimental Configuration

For this series of tests, the Phoenix Fire Department obtained a 41 m (135 ft) by 15 m (50 ft) warehouse (Figure 1) that was scheduled for demolition. The building was a single story with a peaked roof composed of rolled roofing material laid over 51 mm (2 in) by 200 mm (8 in) boards supported on wood trusses. The warehouse was separated into two halves with a wall constructed of 2 x 4 wood studs with 13 mm ($\frac{1}{2}$ in) plywood nailed to one side. The plywood was covered with two layers of 16 mm ($\frac{5}{8}$ in) fire rated gypsum board. The separation wall was built along a truss 27 m (90 ft) from the front of the building.

The trusses used 2 x 12 lumber for the top and bottom chord and various lumber sizes for the web members (Figure 2). The trusses were spaced 4.6 m (15 ft) apart and oriented perpendicular to the long dimension of the building. The peak of the roof was 5.5 m (18 ft) above the floor with the bottom chord of the truss located 3 m (10 ft) above the floor. The trusses rested on bearing walls composed of brick and block.

The front half of the building was 15 m (50 ft) wide and 27 m (90 ft) long overall. This area had been subdivided into several smaller areas (Figure 1). The primary separation was a wall composed of gypsum on wood studs and located along the truss 18 m (60 ft) from the front of the building. This wall went only to the underside of the bottom chord of the truss. A door, 2.3 m (7.5 ft) high and 1.8 m (6 ft) wide, was located in this wall 3.7 m (12 ft) from the east wall. In

addition, there were several 0.24 m (0.79 ft) by 0.46 m (1.5 ft) holes cut through the wall at a height of about 3 m (10 ft) (Figure 3).

Two small rooms were also located along the east wall. These rooms were located on either side of the wall dividing the front room. The larger room was 7 m (24 ft) long and 3 m (10 ft) wide and apparently served as an office. There was a door, 0.9 m (3 ft) wide and 2 m (6.8 ft) high, in the west wall of the office and a small opening, 0.9 m (3 ft) by 0.6 m (2 ft), in the north wall. The smaller room was 1.5 m (5 ft) by 1.8 m (6 ft) and served as a rest room. It had a single door opening with dimensions of 0.9 m (3 ft) wide by 2 m (6.8 ft) high.

The front wall of the warehouse structure had a doorway, approximately 1.8 m (6 ft) wide and 3.2 m (10.5 ft) high, located 4 m (13 ft) from the east wall. There were two glass doors in this doorway. A glass window 2.3 m (7.7 ft) high and 8.5 m (28 ft) wide was located in the front wall approximate 6.4 m (21 ft) from the east wall. The sill of the window was 0.7 m (2.3 ft) high (Figure 4).

The second burn area was 14 m (45 ft) by 15 m (50 ft) with a single doorway in the east wall. The doorway was 2.4 m (8 ft) wide and 2.4 m (8 ft) high. It was located 29.2 m (96 ft) from the front wall of the building and 1.8 m (6 ft) from the separation wall.

The fuel load for the first test, conducted in the front part of the warehouse, consisted of four stacks of ten wood pallets. Each stack of pallets had a mass of approximately 163 kg (360 lb). Three of the stacks were arranged in a triangle in the front half of the space (Figures 5 and 6). A fourth stack of pallets was placed in the center of the second section of the building. Newspaper was placed among the three stacks of pallets, and an electric match was positioned in the newspapers as the ignition source. For the second test, three stacks of ten pallets each were arranged in a triangle in the center of the second section of the building (Figure 6 and 7). An electric match and newspaper were again used as the ignition source.

Five thermocouple arrays were placed along the centerline of the warehouse to obtain temperature data. Data were recorded from the first three during the first test and from the fourth and fifth during the second fire test. The first array was located 4.6 m (15 ft) from the front wall and 7.6 m (25 ft) from the east wall. The second thermocouple array was placed 13.7 m (45 ft) from the front wall and 7.6 m (25 ft) from the east wall. These first two arrays had type K thermocouples located at the roof peak, approximately 19.1 m (62.7 ft) above the floor, and 0.3 m (1 ft), 0.6 m (2 ft), 0.9 m (3 ft), 1.2 m (4 ft), 1.5 m (5 ft), 1.8 m (6 ft), 2.7 m (9 ft), 3.3 m (11 ft), 4 m (13 ft), 4.6 m (15 ft), and 5.5 m (18 ft) below the peak of the roof. The third thermocouple array was approximately 22.9 m (75 ft) from the front wall. The fourth and fifth thermocouple arrays were located 32 m (105 ft) and 36.6 m (120 ft) from the front wall, respectively. The last three arrays had thermocouples located at the roof peak and 0.3 m (1 ft), 0.6 m (2 ft), 0.9 m (3 ft), 1.5 m (5 ft), 2.1 m (7 ft), 2.7 m (9 ft), 3 m (10 ft), 3.3 m (11 ft), 4 m (13 ft), 4.6 m (15 ft), and 5.5 m (18 ft) below the peak of the roof. The spacing of the thermocouples for the first and second arrays differed from the spacing for other arrays because of the suspended ceiling present in the front part of the building.

Carbon monoxide volume fractions were measured at two locations within the structure during each test. Gas samples were continuously withdrawn from the burn area through a 6.3 mm (¼ in) copper tube using a pump. The sample gas was passed through a filter and a cold trap to remove particulates and moisture prior to being analyzed using a nondispersive infrared gas analyzer. During each test, samples were taken at a height of 25 mm (1 in) and 0.9 m (3 ft) above the floor. These heights were selected to be representative of a fire fighter's breathing area when laying on the stomach or crawling on hands and knees, respectively. The sample location for the first test was 15 m (50 ft) from the front wall and 6.1 m (20 ft) from the east wall. In the second test, the sample location was 36.6 m (120 ft) from the front wall or 9.1 m (30 ft) from the test area dividing wall and 7.6 m (25 ft) from the east wall

Each test was video taped and photographed. In addition, an infrared video camera was used to record various parts of each test.

Experiments

A fire was ignited in the newspaper among the three stacks of pallets in the front room of the first test area. Electric matches are matchbooks with a winding of nichrome wire that heats and ignites the matches when an electric current passes through the wire. The fire was allowed to grow to involve a significant portion of the roof structure north of the fire area separation wall. After approximately 25 min, the Phoenix Fire Department extinguished the fire.

For the first test, the flames reached the top of the pallet stacks 40 s after ignition (Figure 8). Smoke became visible coming from a roof top ventilator approximately 60 s after ignition (Figure 9). At approximately 1 ½ min after ignition, flames had reached the ceiling and started spreading along the underside. The entire array of pallets in the front half of the first burn area was involved in fire within 2 min. Adjacent items began igniting due to radiant energy 2 ½ min after ignition. At 3 min after ignition, flames were observed coming from the roof top ventilator. The roof area around the ventilator started burning at 4 min. About this same time, the interior picture became obscured in smoke and the camera was removed at the 4 min mark. At approximately 4 ½ min after ignition, the heavy smoke coming from the structure began to diminish, and the roof fires were mostly out by 5 min after the start of the test (Figure 10). As the test measurements indicated the fire was becoming oxygen deficient, the glass in the front door was removed at 8 min to provide additional oxygen for the fire.

Within 2 min after removal of the front door glass, various fires had reignited on the roof. By 11 min after the start of the test, the northwest portion of the roof was burning and appeared to have burned through in spots. Due to loss of some data signals and possible collapse, the thermocouple and volume fraction measurements were terminated at 13 min. At 14 min, approximately ¼ of the roof, primarily the northwest portion was burning (Figure 11). The entire west side was burning by 17 min, and portions collapsed at about 18 min after ignition. The northeast part of the roof collapsed at 18 min 20 s. By 18 min 35 s, all of the plywood covering

the front windows had started burning and had fallen out of the windows. One minute later, the upper portion of the front wall collapsed into the street. At 23 min, the east section of the roof between the trusses 18 m (60 ft) and 23 m (75 ft) from the front wall collapsed. The test was terminated approximately 25 min after ignition (Figure 12).

In the second test, a fire was again ignited in newspaper among three stacks of pallets placed in the center of the second fire test area. The fire was allowed to grow to involve the entire roof over the second test area. After approximately 30 min, monitoring of test conditions was terminated.

For the second test, the flames reached the top of the pallet stacks 45 s after ignition. The entire array of pallets was involved in fire within 2 ½ min (Figure 13). At approximately 3 min after ignition, flames had reached the ceiling and started spreading across it. Smoke started coming out of the open doorway at approximately 3 ¼ min (Figure 14). Adjacent items began igniting due to radiant energy 3 min 20 s after ignition. The smoke layer appeared to reach the top of the pallet stack at 4 min. At 5 min, the interior picture became obscured in smoke and the camera was removed. Flames started coming out of the doorway at 6 ½ min (Figure 15). At 9 min, various edges of the roof started to burn. The roll-up door collapsed at 13 ½ min and partially blocked the open doorway. Data collection was terminated at 14 min.

Significant portions of the roof were burning at the 14 min mark. A partial collapse of the roof occurred at 15 min and 20 s. At 16 ½ min, additional portions of the roof collapsed with the roof being mostly destroyed by 19 ½ min (Figure 16). An unused door in the southwest portion of the west wall had been sealed with a single course of cinder blocks. These blocks collapsed into the street 24 min after ignition (Figure 17). The upper portion of the rear wall collapsed at 29 min and further monitoring was terminated.

Results

Selected temperature histories obtained during the first test are shown in Figures 18, 19, and 20. The volume fractions and temperatures obtained near the gas sampling locations are shown in Figure 21. With the exception of Figure 19, the temperature histories indicate a relatively well-mixed flashover environment. Approximately 200 s into the first test, the fire became oxygen starved. Opening the front door at about 480 s into the test produced the second set of peaks in Figures 18 through 20. In addition to allowing the fire to resume its growth, opening the front door led to the development of a stratified upper layer as indicated by the divergence of the temperature histories in Figure 18 after the 500 s mark. The lower temperatures at the ceiling and 0.6 m positions in Figure 18 indicate the possibility of roof failure in this location allowing cold air to flow into the building. The sudden decrease of temperature histories in Figure 18 after approximately 650 s indicates additional significant roof collapse in the area of this thermocouple tree. The peak in Figure 19 at the 4 m location prior to 150 s is due to flame impingement on the lower thermocouple during the early stage of the fire. The lack of oxygen and the impact of opening the front door are also evident in Figure 19. The temperatures are

decreasing when the door is opened at approximately 500 s. The temperatures begin to increase but not as rapidly as the ones closer to the door. The dip in the temperature profiles at approximately 650 s is another indication of a partial roof collapse. Additional roof failure beyond 700 s leads to further temperature reductions.

The temperature histories presented in Figure 20 were obtained in the second third of the first section of the warehouse (Figure 1). This part of the warehouse was separated from the other part by a wall that went from the floor to the suspended ceiling (Figure 3). The temperature histories obtained in this area are more stratified than in the other part of the warehouse. The stratification becomes more significant after the front door is opened. In addition, the roof failures occurring in the front part of the warehouse continue to produce increasing temperatures in this area. The temperatures and gas volume fractions presented in Figure 21 are consistent with the fire being oxygen starved by the 300 s point. The concentrations decrease and the temperatures increase after the door is opened.

The temperature histories obtained for the second test are shown in Figures 22 and 23. The volume fractions and temperature obtained near the gas sampling locations for the second test are shown in Figure 24. The affect of the open doorway in the second test (Figure 13) is apparent in the temperature histories shown in Figure 22. At approximately 350 s, the temperatures begin to decrease. At this point flames were observed coming from the open door suggesting a lack of oxygen within the warehouse in the vicinity of the fire near the thermocouples. Similar stratification of the fire environment is illustrated in Figure 23. Initially, the temperature at the ceiling, 5.8 m (19 ft) above the floor, is lower than some of the upper level locations, e.g., 0.6 m (2 ft) and 1.5 m (5 ft) below the ceiling. This effect may be the result of the wood trusses that support the roof and obstruct the flow of hot gases across the ceiling. The carbon monoxide volume fractions shown in Figure 24 correspond with the fire becoming somewhat oxygen starved at about 390 s. The volume fractions are rising rapidly from approximately 280 s to 420 s. Acquisition of gas volume fraction data was terminated at 420 s when equipment and personnel were evacuated from the area. The sudden drop off of volume fraction is the result of this termination. Unfortunately, data acquisition had to be stopped prior to complete collapse. Further work will evaluate the potential for use of sensors with radio output to allow continued monitoring through the collapse phase of the research activity.

The complete data sets for both tests are contained in Appendices A and B. For both tests, the maximum temperatures in the area prior to collapse were 800 °C (1470 °F). Gas temperatures in the second test remained between about 600 °C (1110 °F) and 800 °C (1470 °F) throughout the test. The carbon monoxide volume fractions in the first test exceeded 3 % approximately 5 min after ignition. In the second test, the carbon monoxide volume fraction exceeded 5 % approximately 7 min after ignition. The volume fractions at the 25 mm and 0.9 m locations varied from 0.1 % to a 0.5 %. Variation was greater in the first test than in the second test.

The results presented in this report are subject to some uncertainties. The major components influencing the gas temperature measurements are instrument accuracy, improper placement, and radiation error. According to the manufacturer, the thermocouples used in these tests can have a

standard error of 1 °C to 3 °C. The thermocouple locations were carefully selected to provide a reasonable representation of the local temperature without requiring an exact measurement. A small thermocouple wire diameter was used to minimize radiation effects. Based on the work of Blevins and Pitts [3], the error in gas temperature measurements resulting from radiation effects can be as high as 25 % during the very early stages of the fire. Based on a review of the manufacturer's information and previous experience, the uncertainty associated with the data obtained from the gas analyzers used in this test series is estimated to be approximately ± 1 % of the actual value.

Conclusions

Two fire tests were conducted by the National Institute of Standards and Technology in cooperation with the Phoenix, AZ Fire Department in an ordinary construction, single story warehouse. These fire tests were part of a series of tests being conducted to identify potential methodologies for predicting structural collapse. If technology were available to provide a reliable assessment of structural stability or timely warning of impending collapse, then interior fire fighting operations could be conducted with greater safety. The data obtained from these tests is being used to evaluate the applicability of various fire models for predicting structural collapse. In addition, the test data are useful for investigating the use of new measurement technologies in the fire environment. These investigations include the use of infrared cameras to measure temperature, lasers and sonar to measure displacement, and vibration to predict a change in structural integrity. Specifically, these experiments included sensors for obtaining vibration measurements [4].

The results from the vibration studies will be presented in a future report. While work is continuing to evaluate these technologies for use by the fire service, there are some useful conclusions that can be drawn from these two tests.

According to the 2nd edition of the SFPE Handbook of Fire Protection Engineering, exposure of a person involved in light work, such as walking, to a carbon monoxide level of 1 % for approximately 3 min is sufficient to cause unconsciousness while a carbon monoxide level of 4 % for less than 1 min will cause death [5]. Within about 5 min after ignition, the carbon monoxide levels in both tests rapidly increased to lethal levels. Very similar carbon monoxide volume fractions were measured at the 25 mm and 0.9 m locations during both tests.

The temperature measurements at the two locations were not as similar. The temperatures obtained at the two locations during the first test varied from 50 °C (120 °F) to as much as 150 °C (300 °F). During the second test, the temperature variation between the two locations was as high as 250 °C (480 °F). For reference, unprotected people can tolerate temperatures of 100 °C (212 °F) for approximately 10 min and temperatures of 150 °C (300 °F) for about 5 min when exposed to convected heat [6]. Flashover as indicated by gas temperatures in excess of 600 °C (1100 °F) is reached during both tests about 4 min after ignition. After flashover, temperatures

during the first test decrease but remain about approximately 200 °C (390 °F) throughout the test. Temperatures remain above 400 °C (750 °F) at head height through the second test.

The ability of fire fighters to withstand the extreme temperatures associated with typical building fires is directly related to the thermal performance of their protective clothing and equipment. The National Fire Protection Association standard for interior structural fire fighting clothing requires a minimum Thermal Protective Performance (TPP) rating of 35 [7]. When exposed to a flashover fire, fire fighters wearing garments with a TPP rating of 35 have from 10 s to 20 s to escape before receiving serious burns [8, 9].

Some indication of potential collapse became evident during the tests. Some of these signs have been documented previously in building construction and collapse related textbooks written specifically for the fire service. For example, one text describes signs of potential wall collapse that can be seen in the bricks and mortar of the exterior walls [10]. An example of the cracks that can develop in exterior brick walls during fire exposure is shown in Figure 25. Eventually, a portion of the wall did collapse (Figure 17). The smoke from a building fire has been suggested as possible cue to the collapse potential [11]. Early during the first test smoke (Figure 9) and then flames (Figure 26) were observed coming from a roof top ventilator. As the fire progressed, the ventilator collapsed, the flames disappeared and only smoke could be seen coming from the ventilator (Figure 27). Depending on the stage of the fire, initial exterior appearances can be deceiving.

Acknowledgements

The authors would like to thank the Phoenix Fire Department and Chief Alan Brunacini for inviting NIST to participate in this live fire training exercise. Captain Tom Bates and the rest of the Phoenix Fire Department Safety Section staff deserves special recognition for the invaluable support that he provided to NIST staff during this test series. In addition, the authors would like to express appreciate to Mr. Joe McElvaney of the City of Phoenix City Development Service Department for his hands-on assistance with various aspects of this project. Finally, the authors express gratitude to the United States Fire Administration and Mr. William Troup for their sponsorship and support of this important research.

References

- [1] Beyler, C.L., "Fire Safety Challenges in the 21st Century," Journal of Fire Protection Engineering, Vol. 11, No.1, pp. 4-15, 2001.
- [2] Fire Fighter Fatalities in the United States in 1999, United States Fire Administration, Emmitsburg, MD, July 2000.

- [3] Blevins, L.G., and Pitts, W.M., "Modeling of Bare and Aspirated Thermocouples in Compartment Fires," *Fire Safety Journal*, 33, pp. 239-259, 1999.
- [4] Duron, Z.H., "Early Warning Capabilities for Firefighters," NIST GCR 03-846, National Institute of Standards and Technology, Gaithersburg, MD, February 2003.
- [5] Purser, D.A., "Toxicity Assessment of Combustion Products," The SFPE Handbook of Fire Protection Engineering, 2nd edition, National Fire Protection Association, Quincy, Massachusetts, pp. 2-92 to 2-95, 1995.
- [6] Purser, D.A., "Toxicity Assessment of Combustion Products," The SFPE Handbook of Fire Protection Engineering, 2nd edition, National Fire Protection Association, Quincy, Massachusetts, pp. 2-112 to 2-118, 1995.
- [7] NFPA 1971, "Standard on Protective Ensemble for Structural Fire Fighting," 1997 Edition, National Fire Protection Association, Quincy, MA, 1997.
- [8] Krasny, J.F., Rockett, J.A., and Huang, D., "Protecting Fire Fighters Exposed in Room Fires: Comparison of Results of Bench Scale Test for Thermal Protection and Conditions During Room Flashover," *Fire Technology*, Vol. 24, No. 1, National Fire Protection Association, Quincy, MA, pp. 5-19, February 1988.
- [9] Mell, W. and Lawson, J.R., "A Heat Transfer Model for Fire Fighter's Protective Clothing," NISTIR 6299, National Institute of Standards and Technology, Gaithersburg, MD, January 1999.
- [10] Brannigan, F.L., "Chapter 4 - Ordinary Construction," Building Construction for the Fire Service, Third edition, National Fire Protection Association, Quincy, Massachusetts, pp. 157, 1994.
- [11] Brannigan, F.L., "Chapter 4 – Ordinary Construction," Building Construction for the Fire Service, Third edition, National Fire Protection Association, Quincy, Massachusetts, pp. 185, 1994.

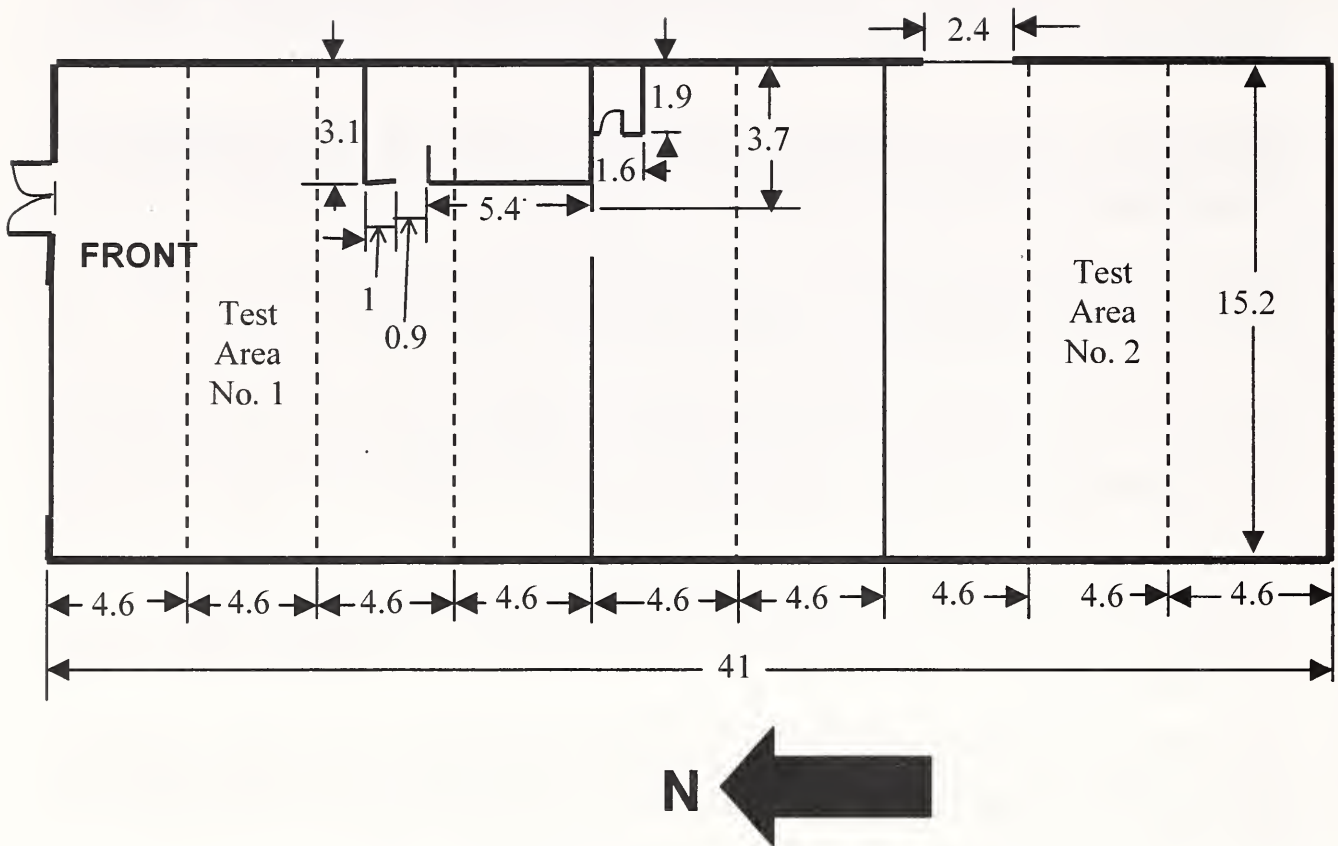

Figure 1. Plan view of warehouse showing layout and dimensions (dimensions in meters).

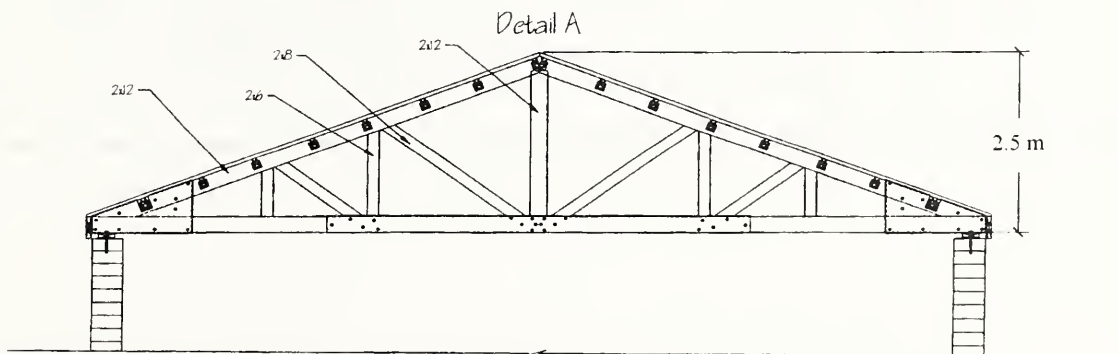
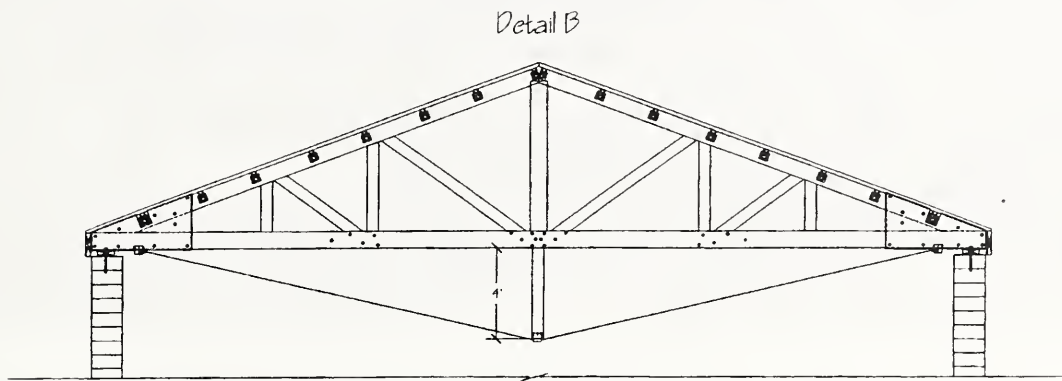
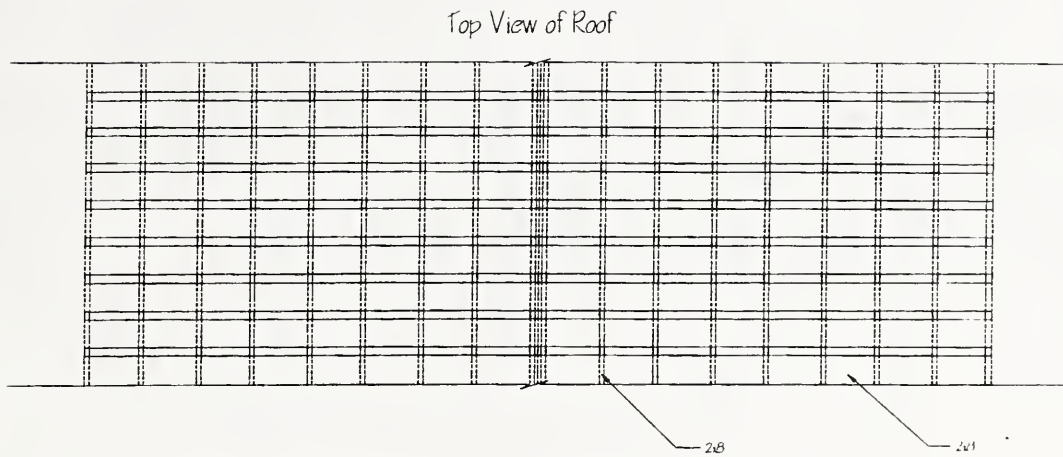

Figure 2. Plan and elevation views showing details of wood trusses supporting the roof of the warehouse.

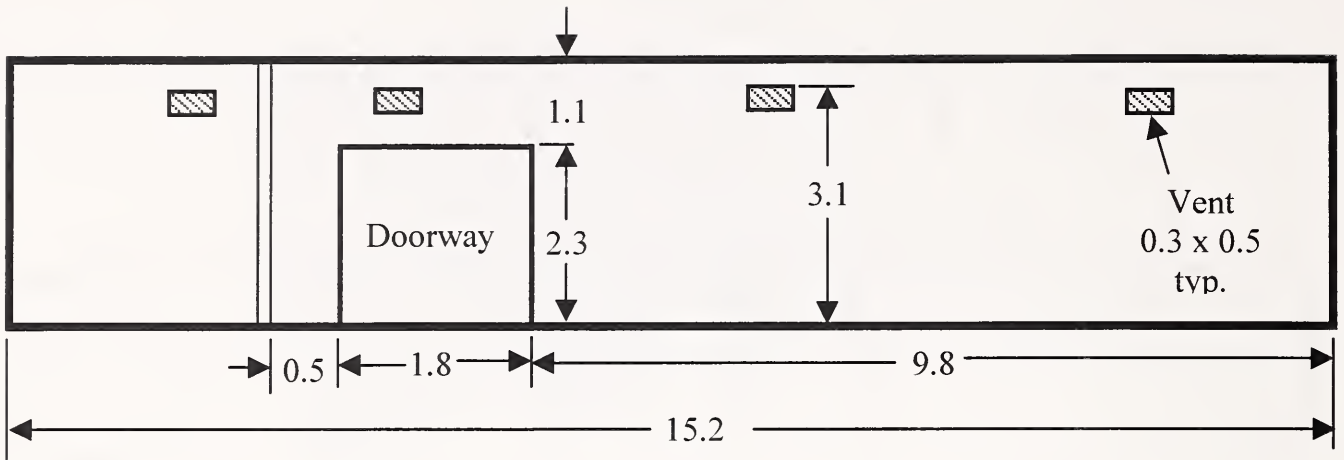

Figure 3. Elevation view of wall dividing the two areas used for the first test (dimensions in meters).

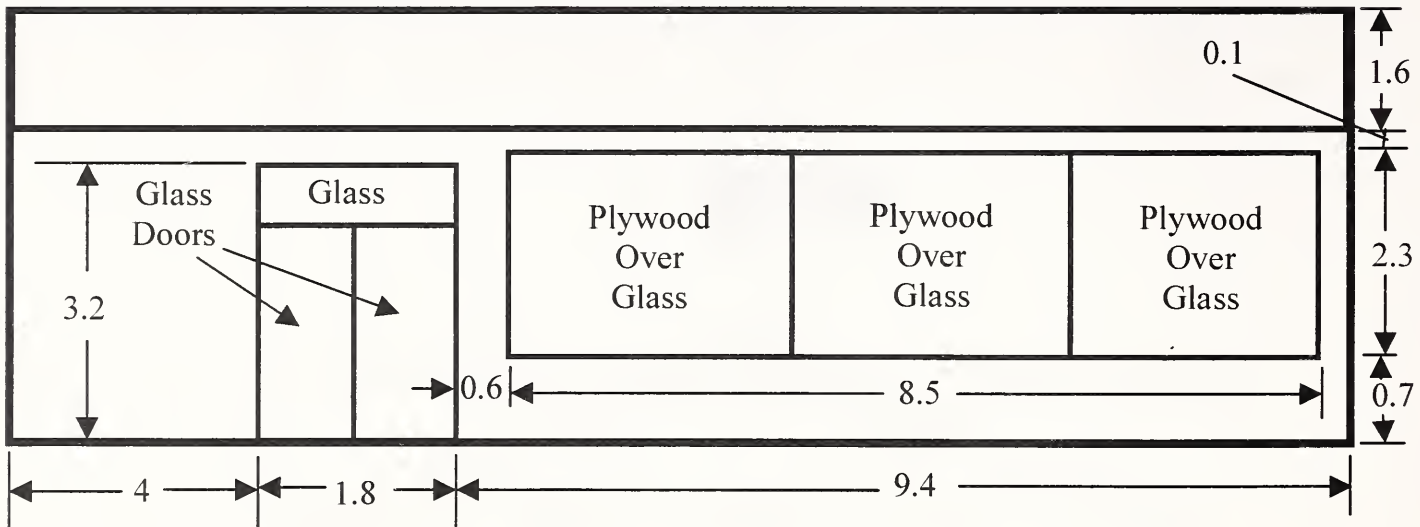

Figure 4. Elevation view showing front wall of area used for first test (dimensions in meters).

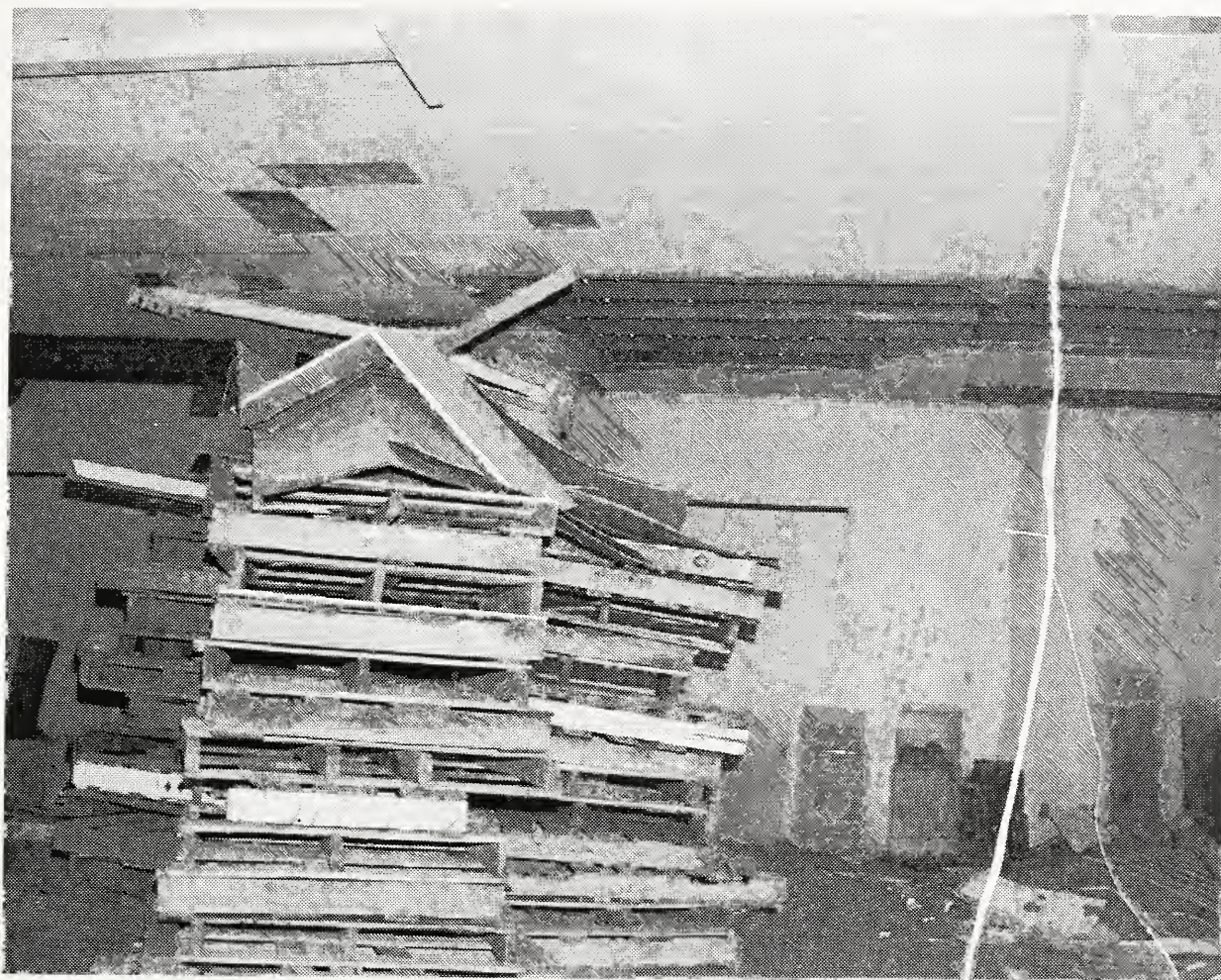

Figure 5. Photograph showing the placement of wood pallets in the front part of the warehouse used for the first test.

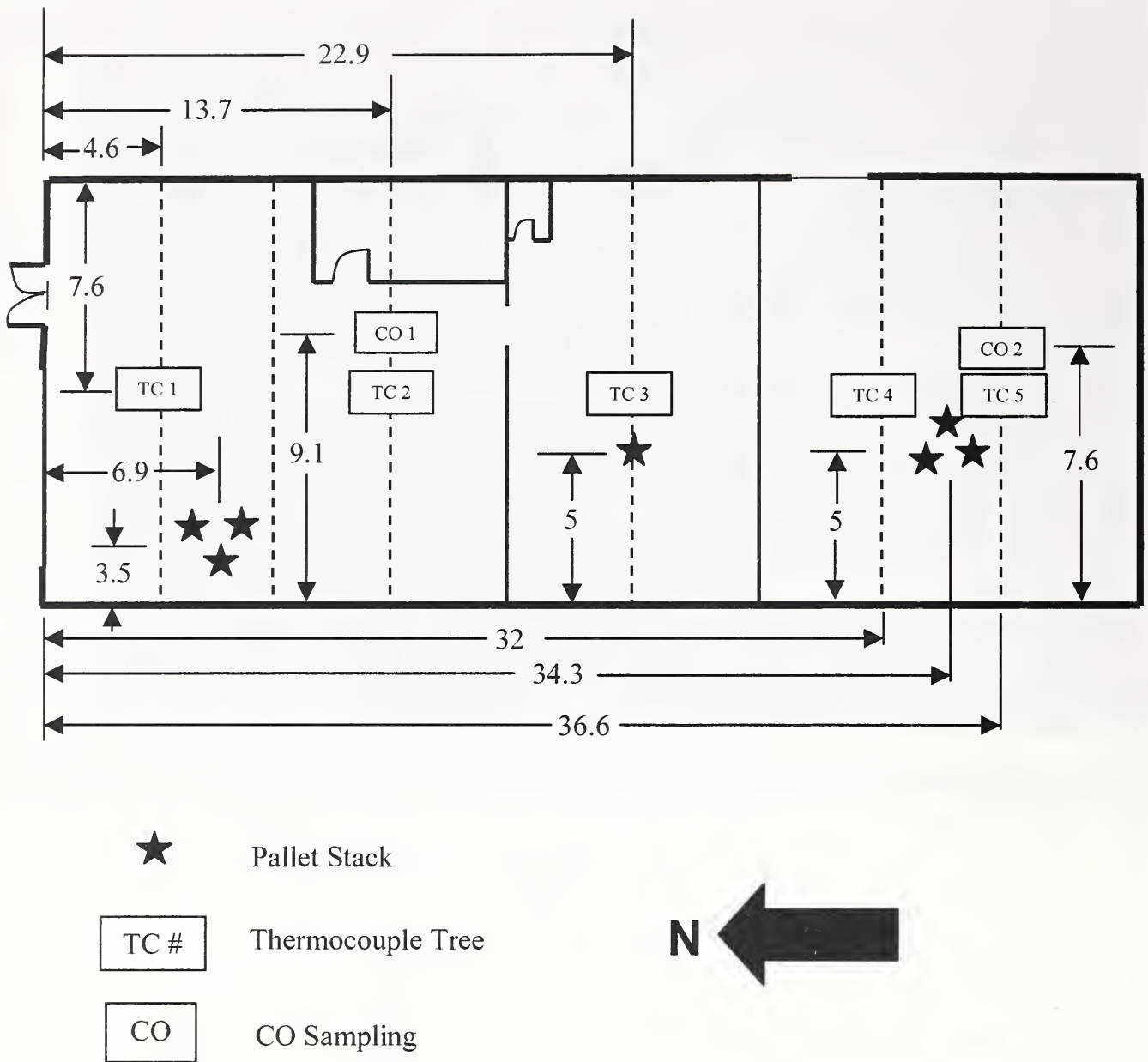

Figure 6. Plan view of warehouse showing locations of measuring instruments and fuel packages (dimensions in meters).



Figure 7. Photograph showing placement of wood pallets and adjacent thermocouple tree in the portion of the warehouse used for the second test.



Figure 8. Photograph of front of warehouse with flames visible through front door at the start of the first test.



Figure 9. Photograph of smoke coming from roof top ventilator during the first test.

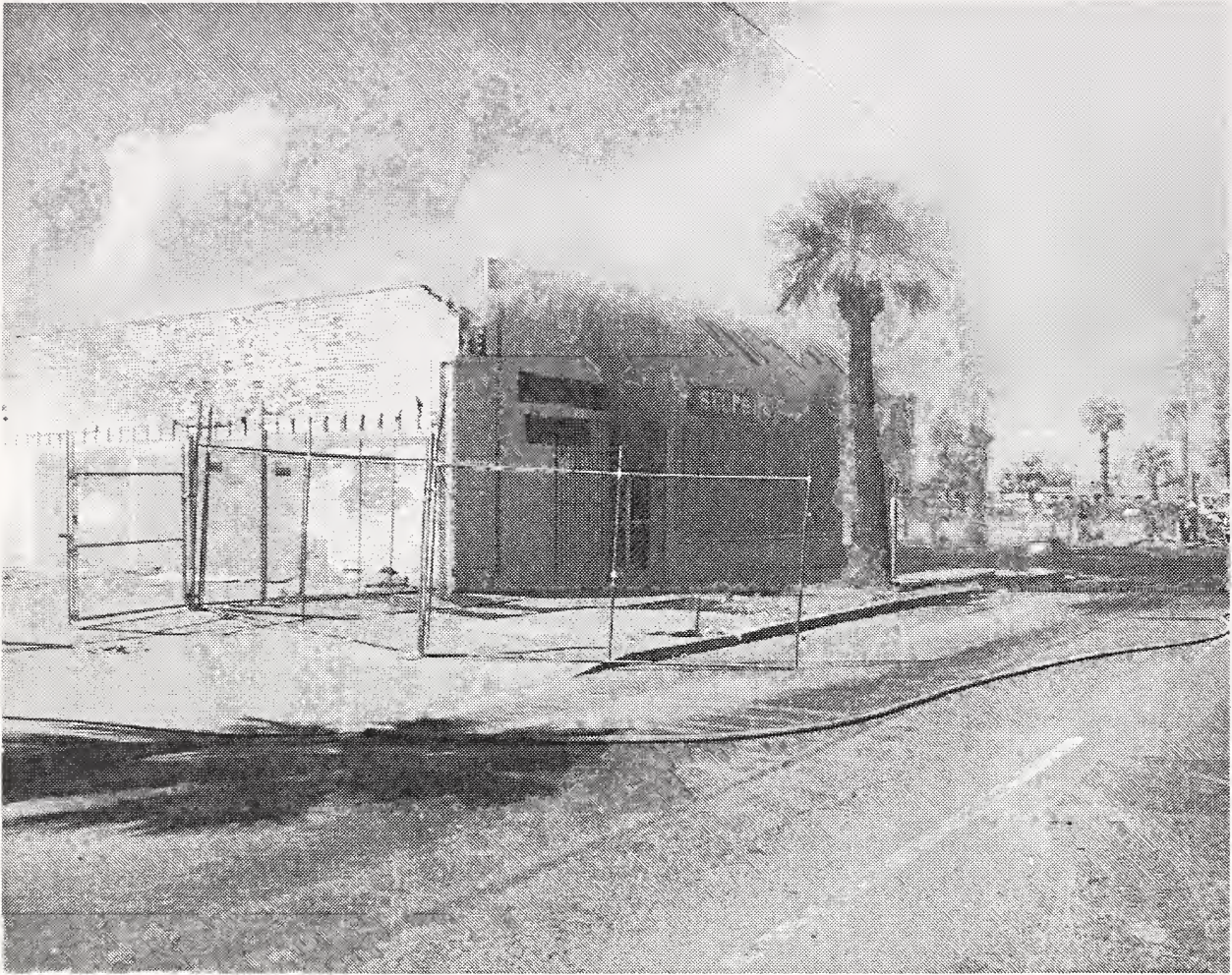

Figure 10. Photograph showing smoke coming from roof and front of warehouse as fire is becoming oxygen deficient during the first test.



Figure 11. Photograph showing fire involving significant portion of roof structure with partial collapse beginning.



Figure 12. Photograph showing the warehouse at the conclusion of the first test with the roof structure over the front half completely gone.

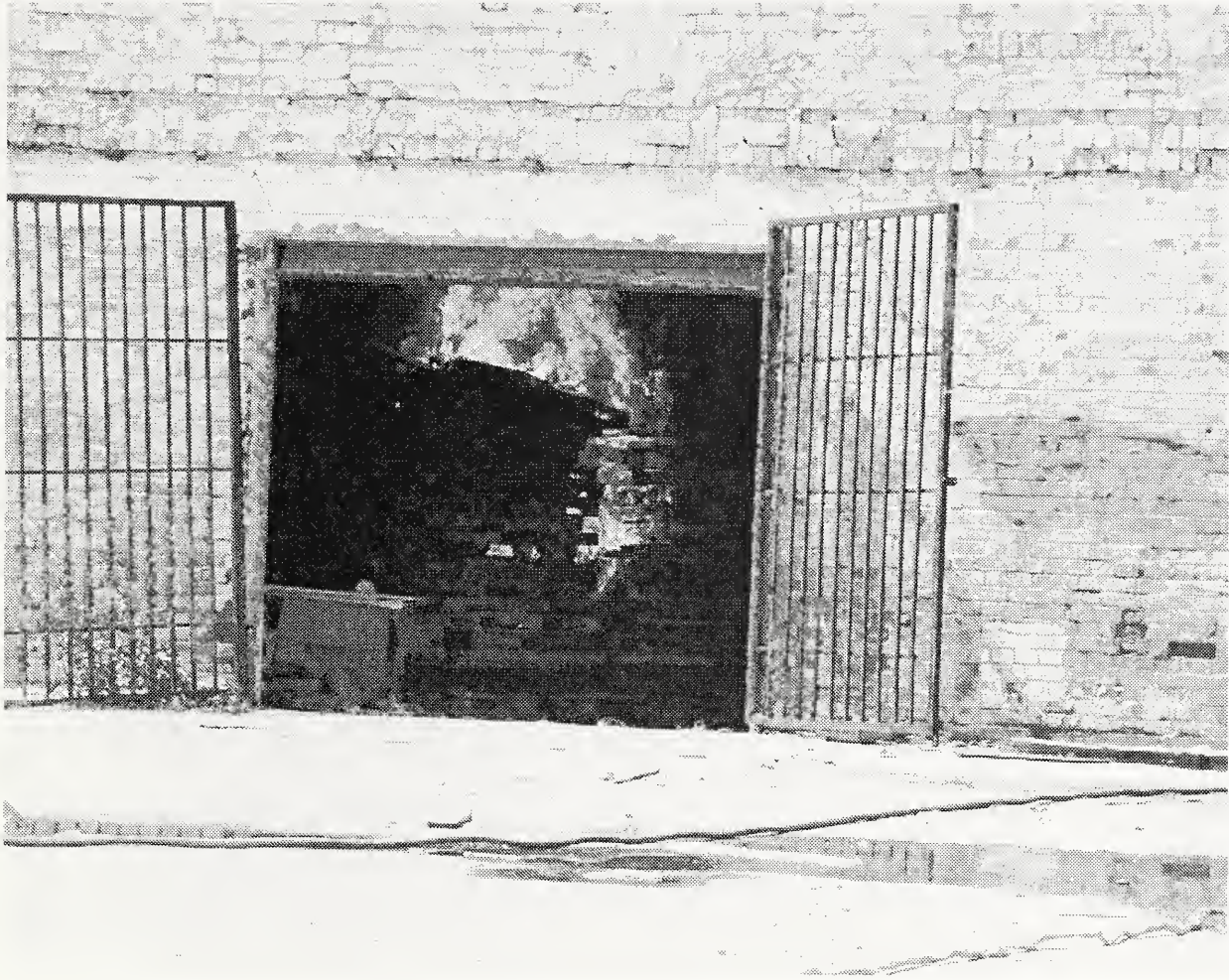

Figure 13. Photograph of fully involved fuel package through open door after the start of the second test.



Figure 14. Photograph of smoke coming from open door during second test.



Figure 15. Photograph showing flames coming from open door during second test.



Figure 16. Photograph showing flames through open door and burning roof during the second test.



Figure 17. Photograph showing partial collapse of the rear and side walls after the second test.

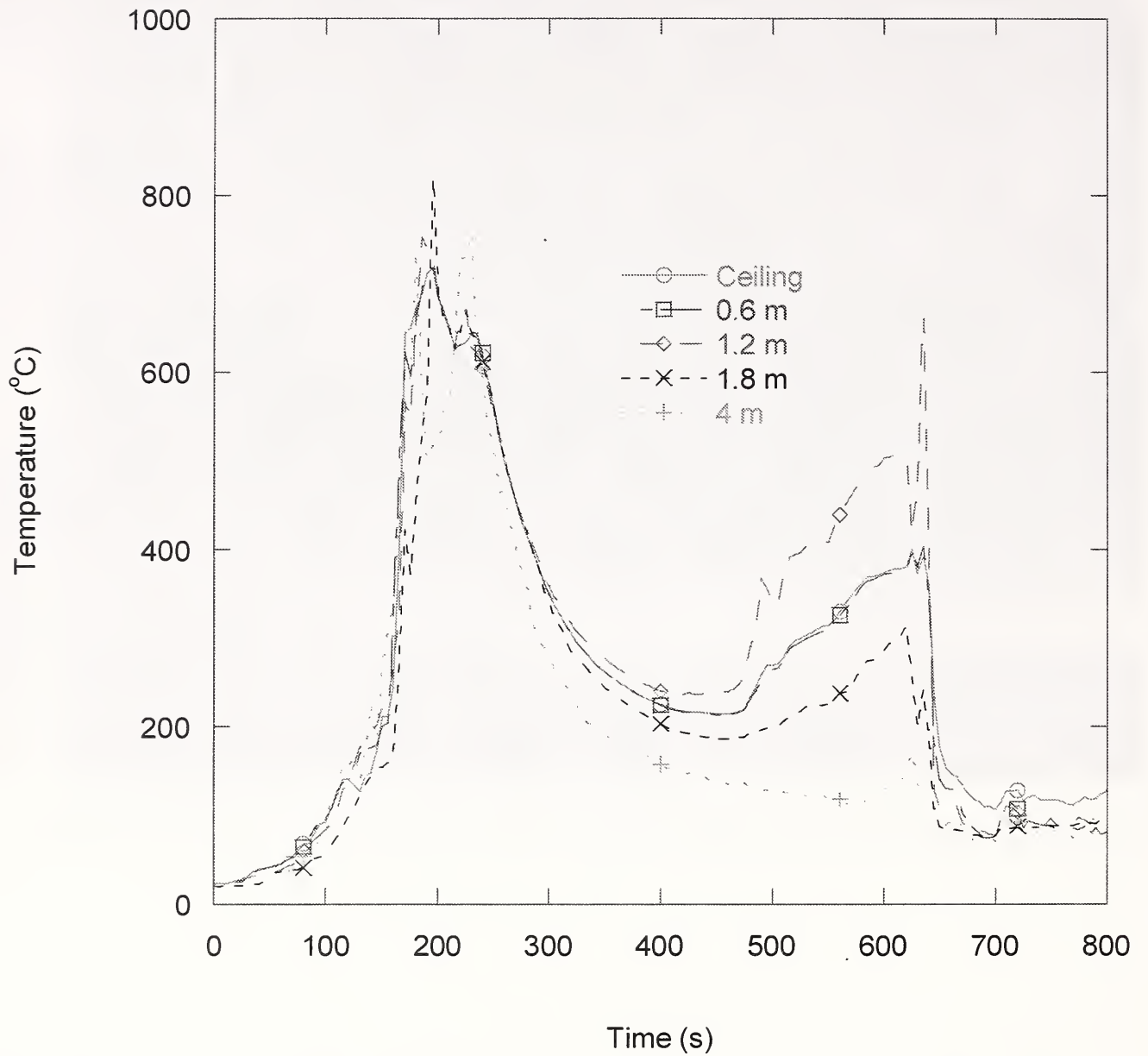

Figure 18. Graph showing time-temperature history for thermocouples at the ceiling, 0.6 m, 1.2 m, 1.8 m, and 4 m below the ceiling and approximately 4.6 m from the front door during the first test.

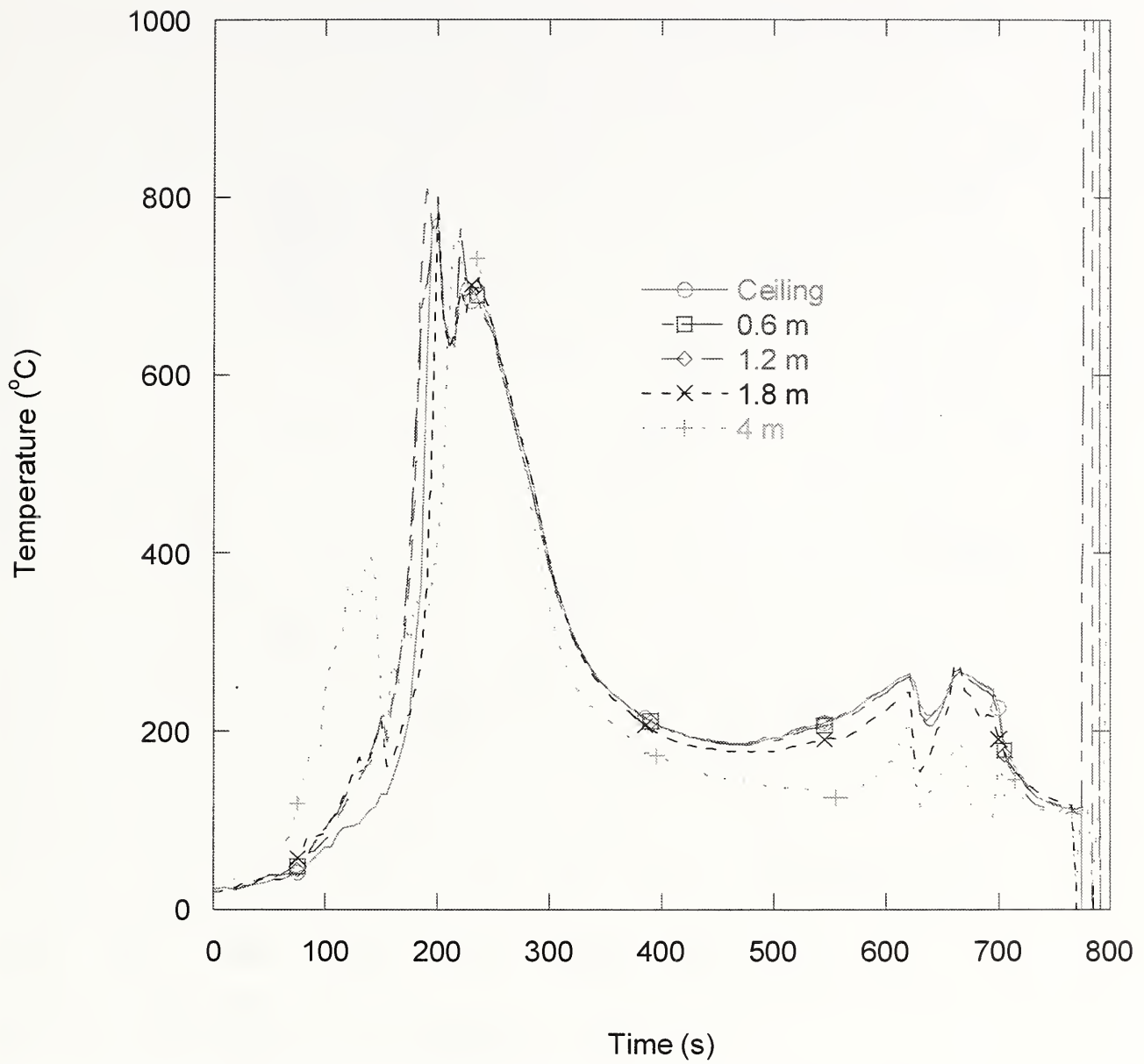

Figure 19. Graph showing time-temperature history for thermocouples at the ceiling, 0.6 m, 1.2 m, 1.8 m, and 4 m below the ceiling and approximately 13.7 m from the front door during the first test.

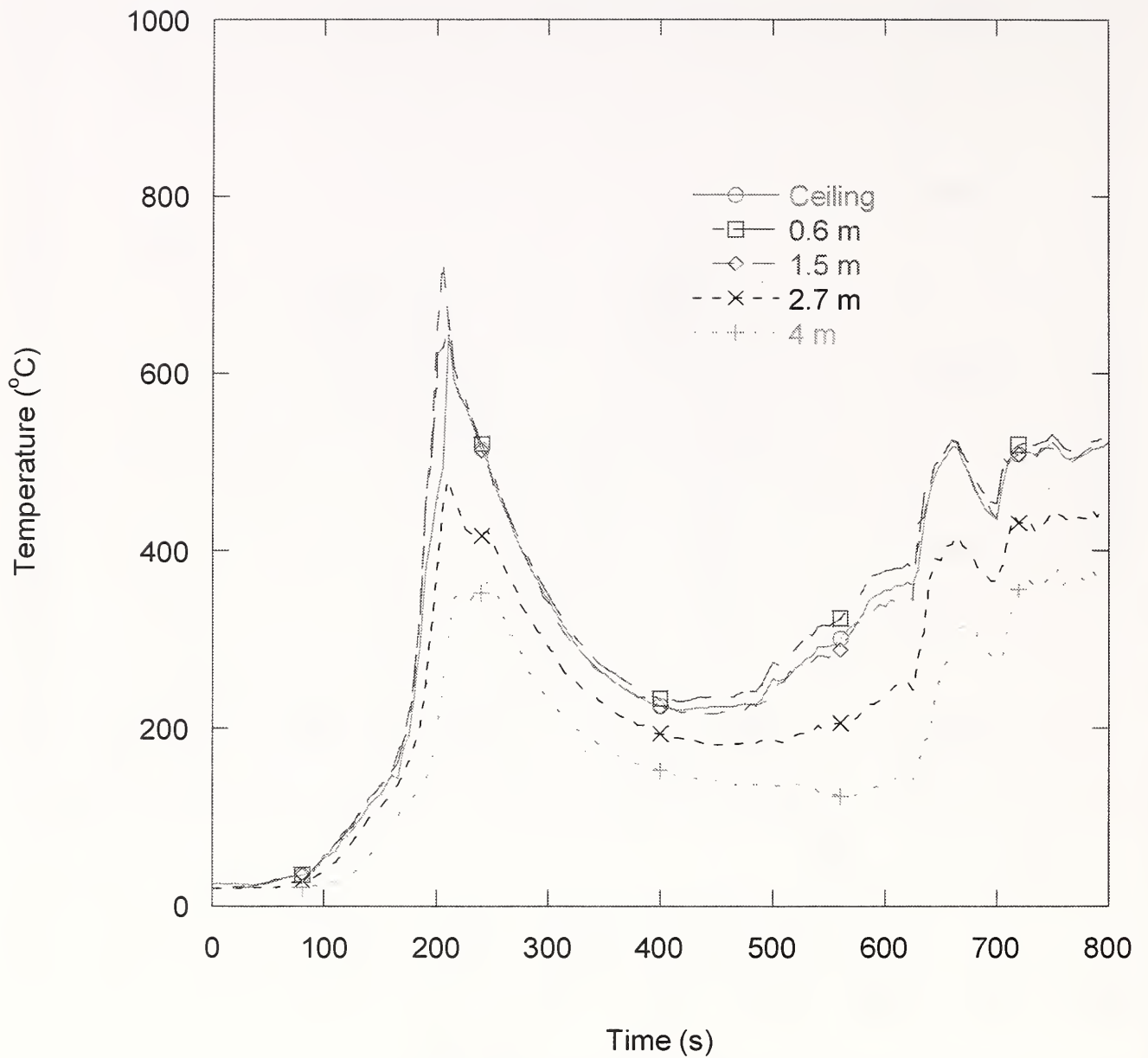

Figure 20. Graph showing time-temperature history for thermocouples at the ceiling, 0.6 m, 1.5 m, 2.7 m, and 4 m below the ceiling and approximately 22.9 m from the front door during the first test.

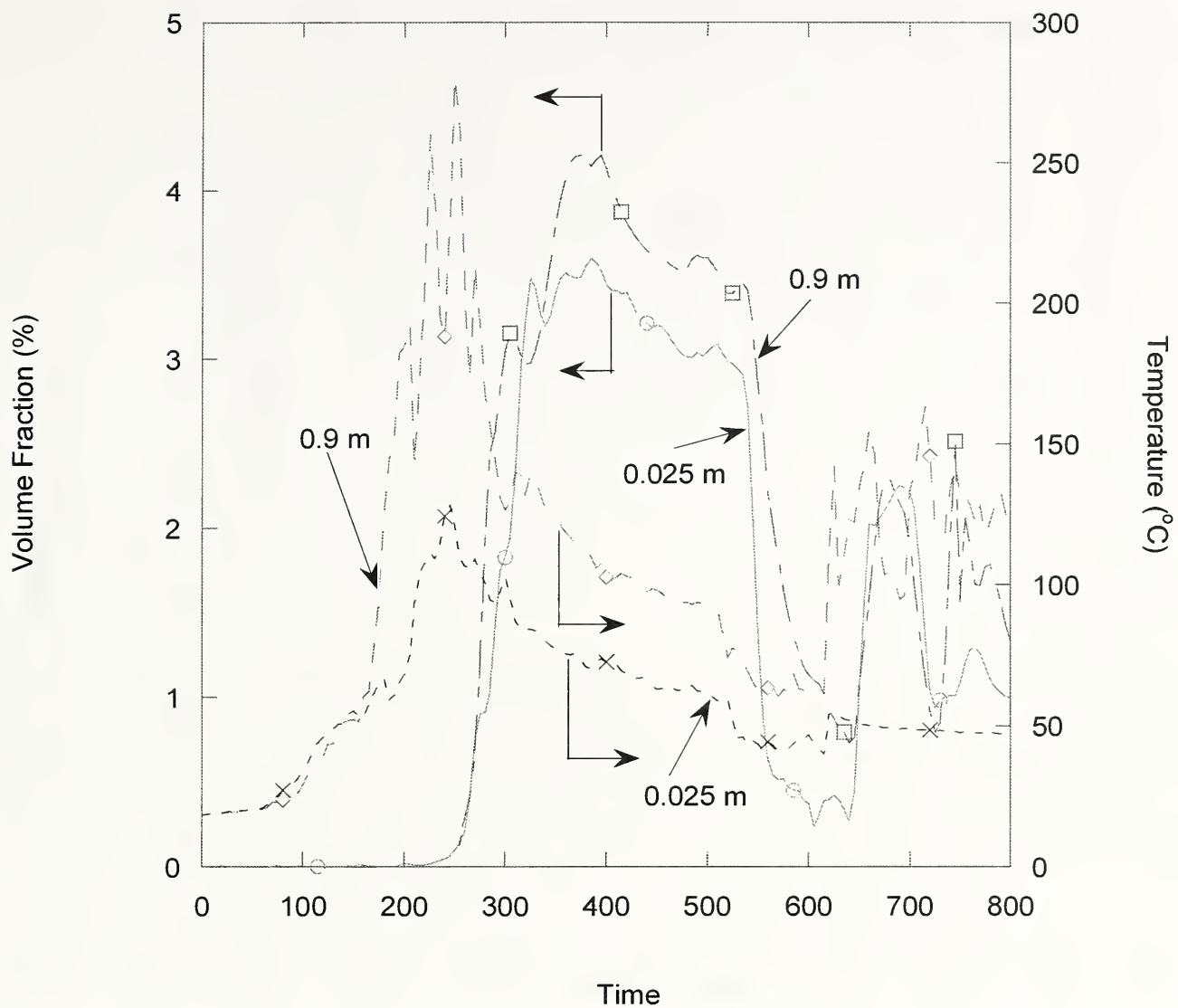

Figure 21. Graph showing carbon monoxide volume fractions at 0.025 m and 0.9 m above the floor and 15 m from the front door during the first test.

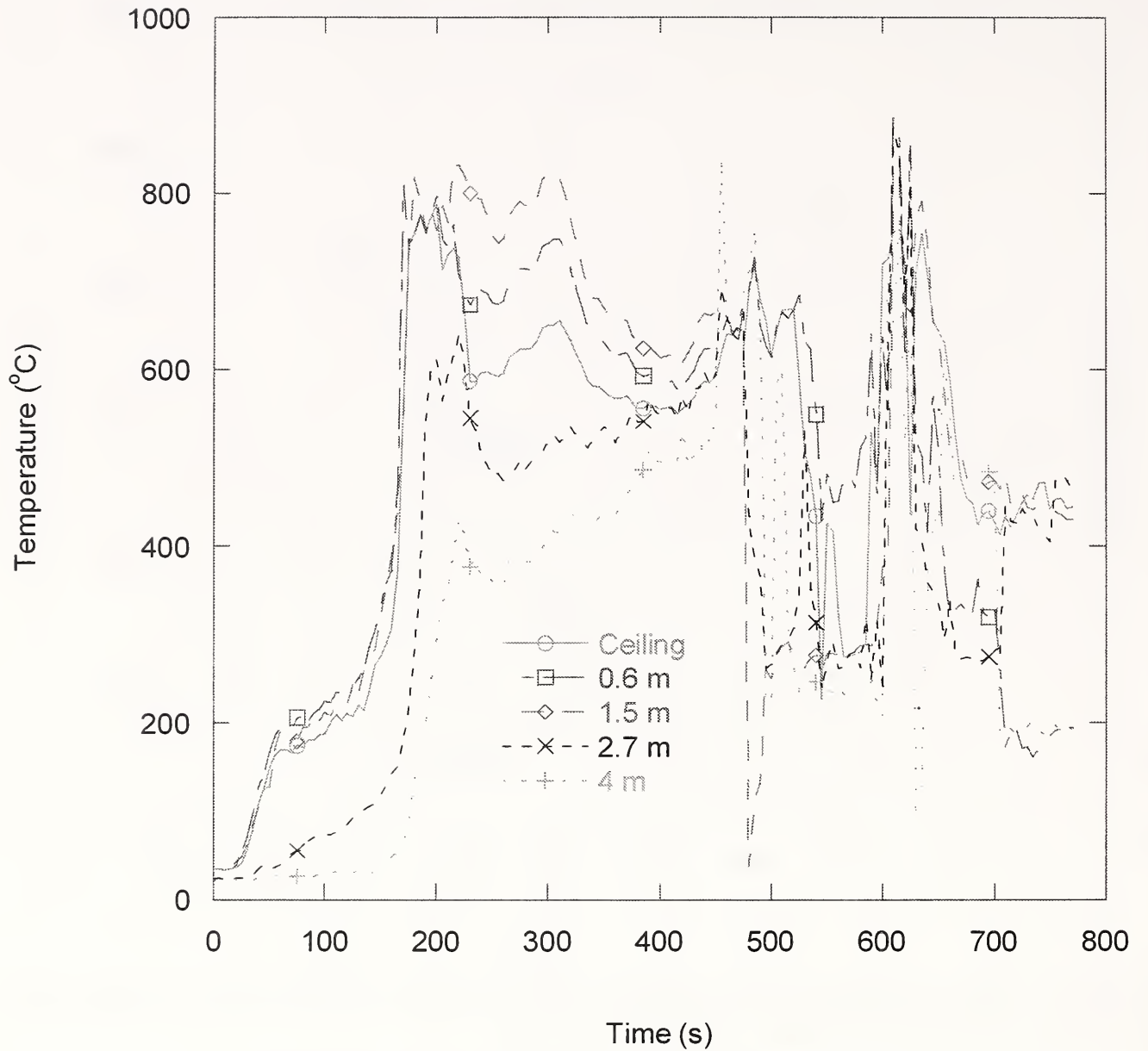

Figure 22. Graph showing time temperature history for thermocouples at the ceiling, 0.6 m, 1.5 m, 2.7 m, and 4 m below the ceiling and approximately 32 m (4.5 m from the test area dividing wall) from the front door during the second test.

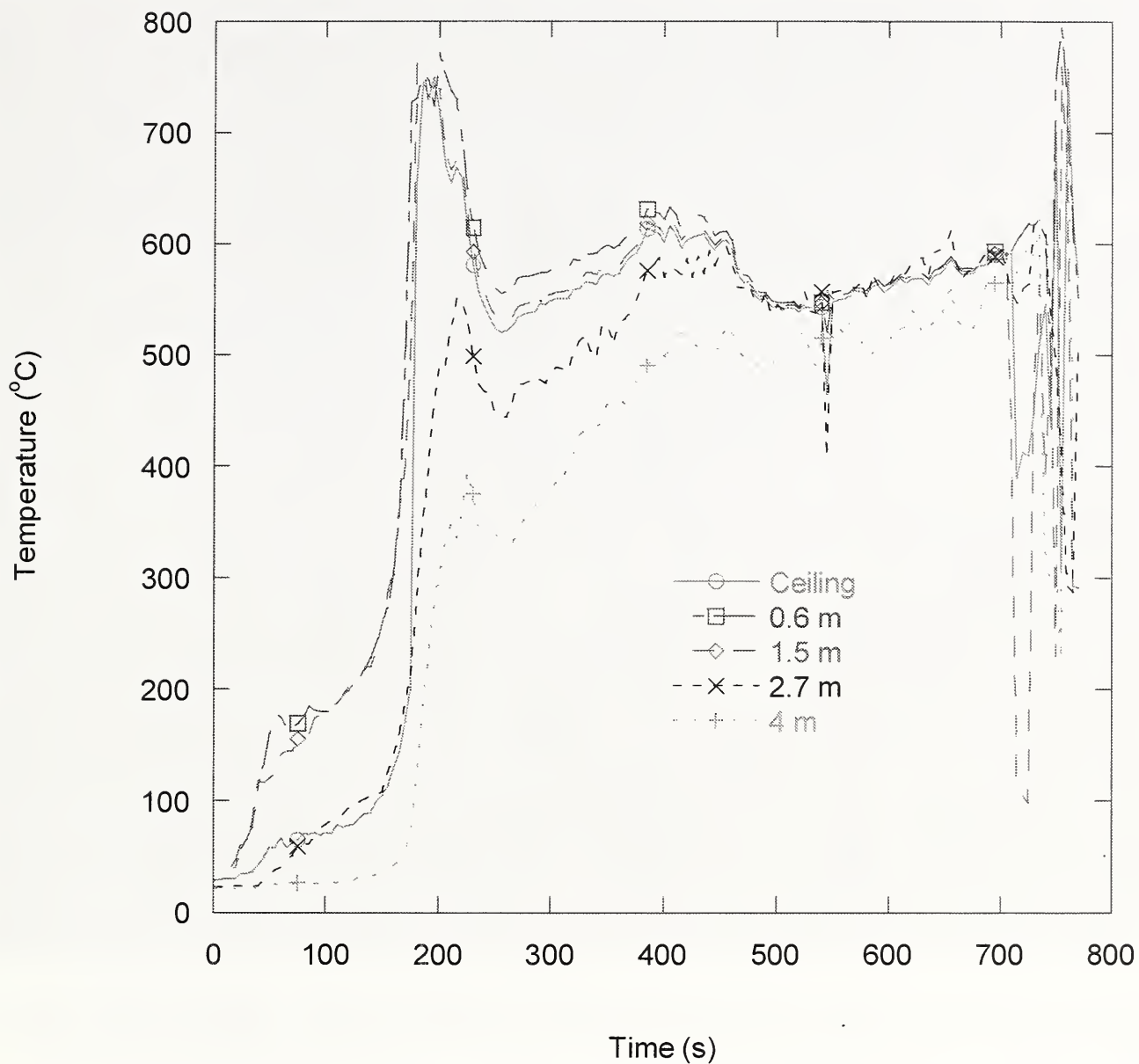

Figure 23. Graph showing time temperature history for thermocouples at the ceiling, 0.6 m, 1.5 m, 2.7 m, and 4 m below the ceiling and approximately 36.6 m (9.1 m from the test area dividing wall) from the front door during the second test.

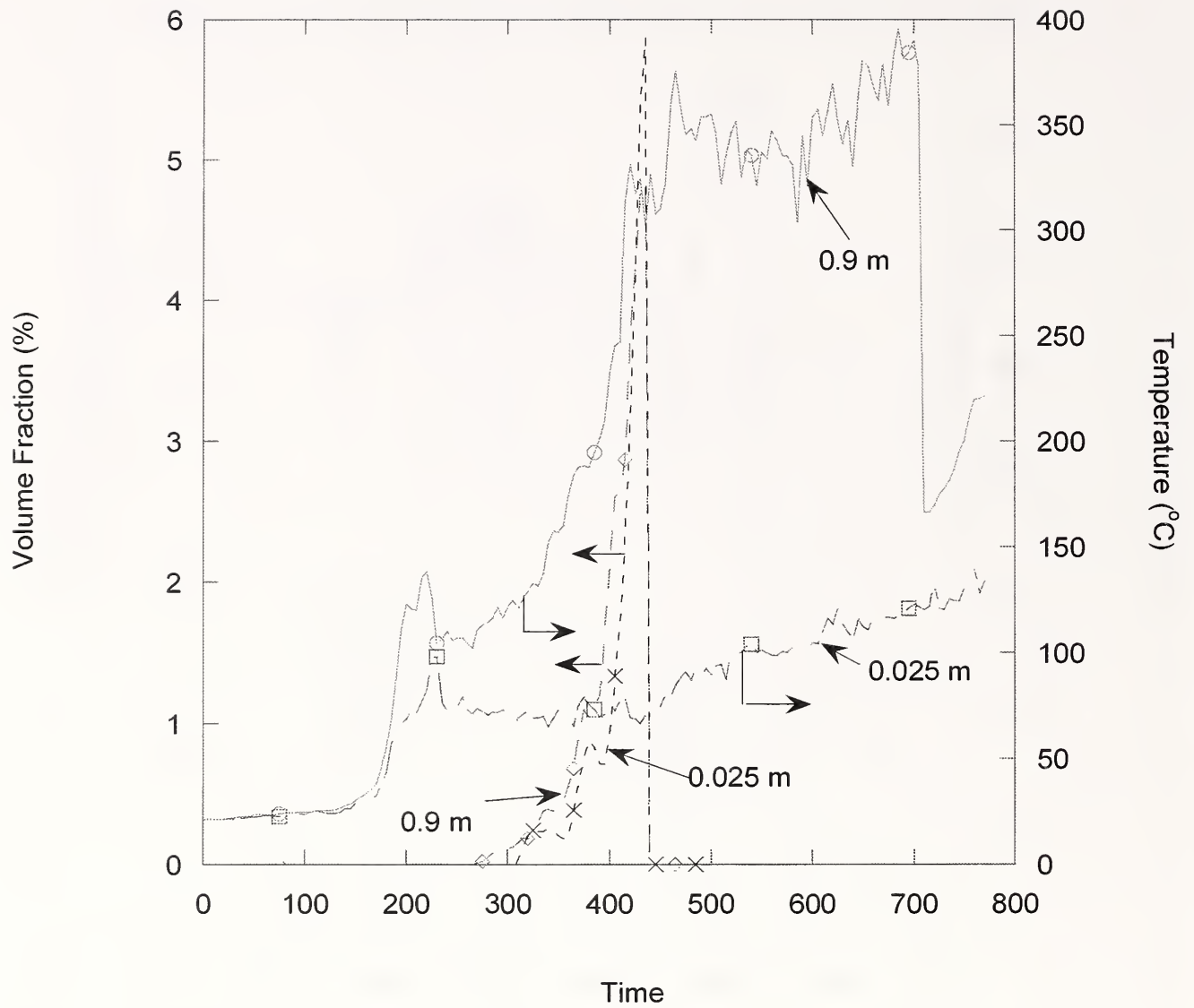

Figure 24. Graph showing carbon monoxide volume fractions at 0.025 m and 0.9 m above the floor and 36.6 m from the front door (9.1 m from the test area dividing wall) during the second test.

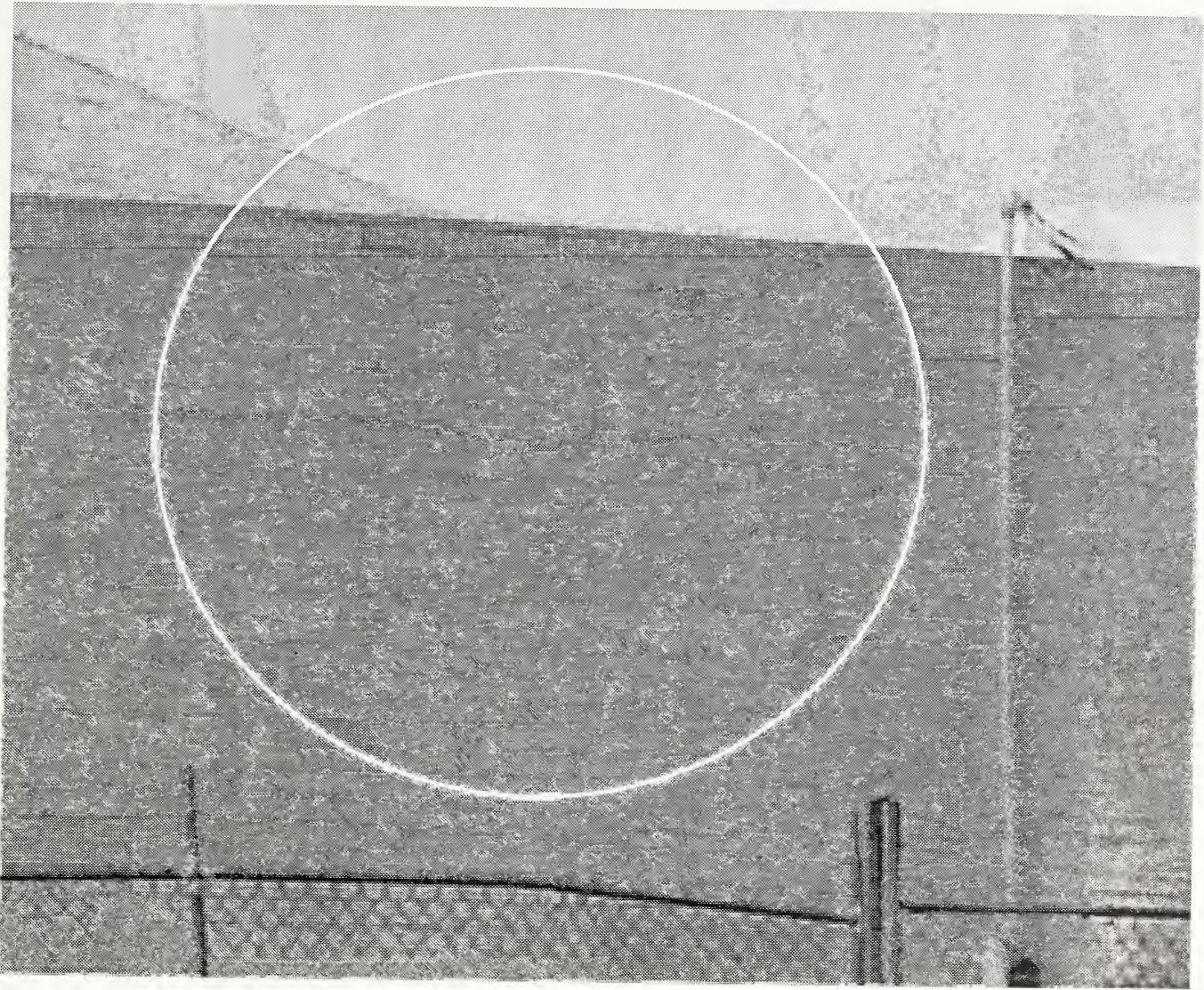

Figure 25. Photograph of rear wall showing developing crack in the wall.

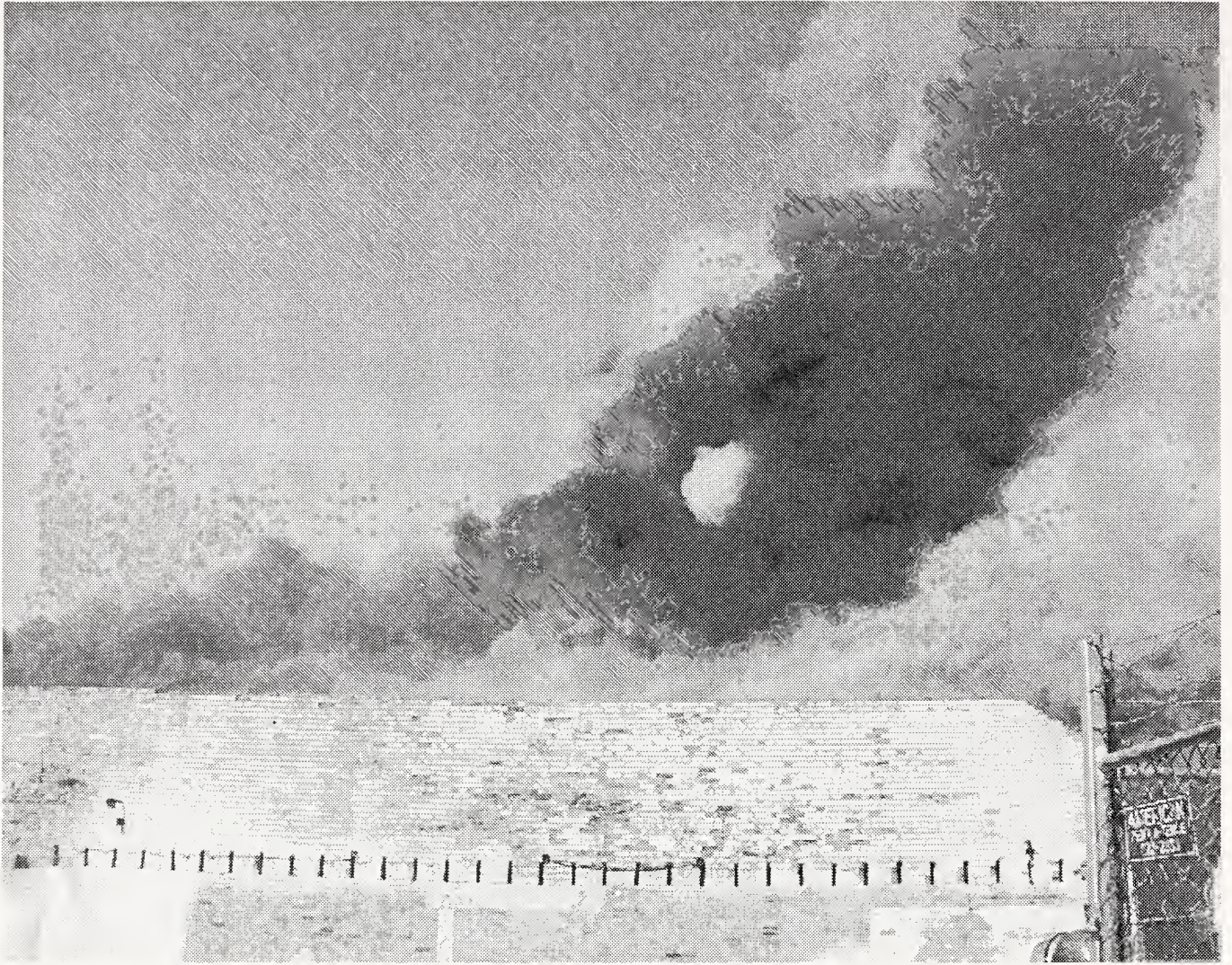

Figure 26. Photograph of roof area showing flames coming from ventilator during first test.

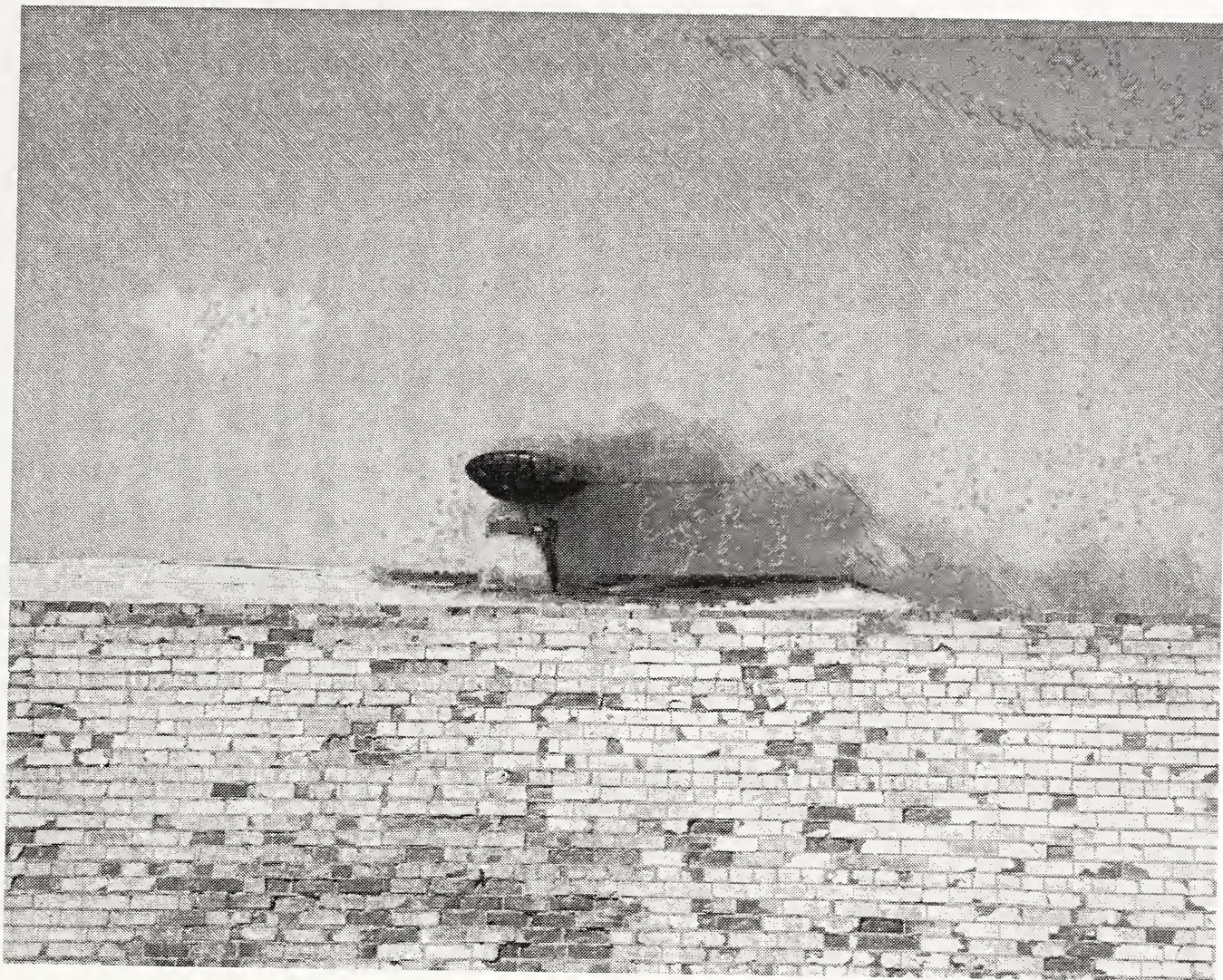

Figure 27. Photograph of roof top ventilator after it collapsed due to severe heat exposure.

Appendix A

Temperature measurements (°C) at location 1, 4.6 m from front of building, obtained during first test

Time (s)	Tree 1 Ceiling	Tree 1 0.3 m	Tree 1 0.6 m	Tree 1 0.9 m	Tree 1 1.2 m	Tree 1 1.5 m	Tree 1 1.8 m	Tree 1 2.7 m	Tree 1 3.3 m	Tree 1 4 m	Tree 1 4.6 m	Tree 1 5.5 m
-60	24	23	22	21	21	20	20	20	20	18	18	18
-55	24	23	22	21	21	20	20	20	20	18	18	18
-50	23	23	22	21	21	20	20	20	20	18	18	18
-45	24	23	22	21	21	20	20	19	20	18	18	18
-40	24	23	21	21	21	20	20	20	20	19	18	19
-35	24	23	22	21	21	20	20	20	20	19	18	19
-30	24	23	21	21	21	20	20	20	20	18	18	19
-25	24	23	22	21	21	20	20	20	20	19	18	19
-20	24	23	22	21	21	20	20	20	20	18	19	19
-15	24	23	22	21	21	20	20	20	20	18	18	18
-10	24	23	22	22	21	20	20	20	20	18	19	19
-5	24	23	22	21	21	20	20	20	20	19	18	19
0	24	23	22	21	21	20	20	20	20	19	18	19
5	24	23	22	21	21	20	20	20	21	29	19	19
10	23	23	22	21	21	20	20	20	23	27	19	19
15	25	26	26	24	23	22	20	20	21	24	19	19
20	26	26	26	26	25	24	20	20	21	28	19	19
25	29	28	27	27	26	25	21	20	20	28	19	19
30	32	32	31	29	29	28	21	20	20	33	19	19
35	37	37	36	34	32	30	21	21	20	32	19	19
40	40	41	39	36	34	32	23	23	20	31	19	20
45	40	41	40	38	35	33	27	27	23	27	19	20
50	42	43	42	39	36	35	30	31	25	33	19	19
55	43	45	44	42	37	36	35	38	34	29	19	20
60	46	48	46	42	39	39	36	38	30	35	20	20
65	53	53	50	48	43	42	39	34	24	33	20	21
70	53	54	52	50	44	45	38	35	22	46	21	22
75	58	60	58	55	50	49	39	37	22	45	24	23
80	68	71	65	60	60	58	41	40	23	54	23	25
85	69	72	73	69	66	62	44	46	24	56	24	26
90	81	87	85	79	74	73	51	51	24	56	24	25
95	91	97	94	85	77	73	54	49	31	78	26	29
100	92	98	95	88	85	84	59	57	28	82	29	31
105	110	116	109	96	91	88	67	61	38	124	32	35
110	124	133	127	114	105	103	77	71	42	125	33	39
115	140	149	137	128	130	125	88	84	41	160	37	37
120	141	152	143	139	136	131	97	94	49	155	46	39
125	135	144	148	153	159	141	107	105	54	170	52	39
130	128	142	171	174	177	171	123	116	59	140	57	41
135	143	155	174	181	187	182	134	121	61	176	60	44
140	149	158	177	191	193	180	146	137	74	227	64	49
145	172	186	179	194	203	200	153	138	96	173	68	54
150	212	229	200	226	222	211	155	143	92	268	86	53
155	212	232	205	221	228	226	159	152	103	313	100	52
160	244	263	335	270	270	265	176	169	125	342	109	58
165	405	335	498	336	324	300	267	184	165	429	132	69
170	645	587	622	371	566	398	421	270	326	576	130	77
175	650	647	597	597	549	556	372	386	279	595	145	84
180	672	678	659	710	662	564	454	397	323	728	177	91
185	688	697	693	716	753	710	530	425	450	591	205	133
190	713	696	717	738	740	773	577	497	600	501	211	143
195	717	680	718	717	729	725	818	832	804	517	240	161
200	685	672	685	692	685	678	688	681	670	520	269	168
205	665	661	667	670	668	661	658	654	654	558	290	197
210	648	644	648	652	649	642	649	642	667	564	331	254
215	628	627	627	629	628	623	626	636	655	638	380	279
220	630	631	631	633	665	628	647	634	682	730	425	303
225	633	636	639	636	671	636	669	631	696	728	462	314
230	643	638	645	636	627	640	644	626	631	760	468	339

Time (s)	Tree 1 Ceiling	Tree 1 0.3 m	Tree 1 0.6 m	Tree 1 0.9 m	Tree 1 1.2 m	Tree 1 1.5 m	Tree 1 1.8 m	Tree 1 2.7 m	Tree 1 3.3 m	Tree 1 4 m	Tree 1 4.6 m	Tree 1 5.5 m
235	639	631	644	629	623	637	634	616	604	634	500	338
240	618	610	622	604	605	616	611	601	576	604	478	321
245	589	581	592	572	580	590	587	576	543	539	442	312
250	558	551	561	547	554	562	560	547	515	516	432	326
255	527	522	531	518	526	532	527	514	489	464	413	314
260	500	495	503	492	500	505	500	486	463	465	380	311
265	475	470	478	469	477	481	477	462	441	429	353	281
270	453	448	455	448	456	460	453	440	417	403	329	269
275	434	429	436	432	437	442	437	426	397	378	315	266
280	416	411	418	417	421	425	421	410	379	359	303	256
285	398	393	400	402	405	408	399	376	358	319	279	226
290	381	376	381	386	389	392	381	357	339	296	262	217
295	365	360	365	371	374	375	355	336	327	289	245	184
300	350	345	350	357	360	360	339	322	311	282	236	187
305	337	332	337	344	347	346	323	312	301	264	219	183
310	325	322	325	334	336	334	313	300	290	258	211	179
315	315	311	315	324	325	323	299	288	280	247	202	179
320	305	301	305	315	316	313	285	276	266	233	195	179
325	296	292	295	306	307	304	278	268	261	225	192	170
330	288	285	287	299	300	297	272	262	255	209	184	167
335	281	278	280	293	294	290	265	256	246	205	180	161
340	274	271	274	287	288	284	257	248	241	201	177	154
345	268	265	267	282	282	277	250	240	235	198	174	152
350	262	260	262	277	277	272	244	235	230	194	167	145
355	257	255	256	272	271	266	239	230	225	187	159	145
360	252	250	252	268	268	262	234	225	221	183	160	144
365	248	245	247	265	263	258	230	221	217	179	157	144
370	244	241	243	260	259	254	226	218	212	176	152	140
375	241	238	240	257	256	251	222	215	208	176	154	136
380	237	234	236	254	253	247	218	211	203	174	156	130
385	234	231	233	250	248	243	214	208	197	169	155	127
390	231	228	230	248	246	242	211	204	191	165	150	124
395	228	225	227	244	243	239	207	201	189	161	150	120
400	225	222	224	241	241	237	204	197	191	158	148	120
405	223	220	222	240	238	236	200	195	189	154	144	121
410	221	217	220	237	236	233	198	194	184	153	140	121
415	219	215	218	237	235	232	196	192	185	149	139	118
420	218	214	217	237	236	233	194	189	185	148	136	119
425	217	214	216	238	238	236	192	188	183	148	132	118
430	217	213	216	237	237	235	191	186	179	146	131	117
435	216	212	215	237	237	235	189	185	179	146	126	117
440	216	212	215	237	238	236	189	184	178	143	129	116
445	215	211	214	238	237	235	188	183	176	139	131	115
450	215	210	214	238	237	234	187	182	176	137	125	113
455	214	210	213	238	239	234	186	182	174	137	125	111
460	214	210	213	241	240	233	187	181	173	135	126	113
465	215	211	215	244	243	238	188	181	173	135	124	113
470	217	213	216	246	248	243	189	182	173	134	123	112
475	220	215	220	257	261	254	189	182	172	137	121	111
480	234	226	232	306	290	272	193	182	174	134	117	110
485	244	234	241	320	312	282	194	183	175	133	115	108
490	258	247	254	343	367	309	197	185	179	130	117	105
495	269	256	265	360	355	312	198	189	179	129	119	103
500	270	256	265	354	338	303	197	187	182	129	118	102
505	271	257	266	356	339	310	201	189	182	128	117	102
510	279	266	275	372	374	334	206	194	185	127	118	101
515	292	279	288	397	391	356	212	197	187	125	116	96
520	297	282	293	403	395	350	215	199	180	126	118	102
525	299	284	295	403	396	358	218	201	185	123	117	104
530	304	288	299	409	403	365	222	205	188	122	113	103
535	307	291	302	414	406	365	223	208	190	121	109	96
540	311	295	305	418	407	371	225	210	195	123	110	91
545	313	298	308	419	406	382	225	211	189	123	109	91
550	315	299	310	419	409	380	227	213	192	119	104	89

Time (s)	Tree 1 Ceiling	Tree 1 0.3 m	Tree 1 0.6 m	Tree 1 0.9 m	Tree 1 1.2 m	Tree 1 1.5 m	Tree 1 1.8 m	Tree 1 2.7 m	Tree 1 3.3 m	Tree 1 4 m	Tree 1 4.6 m	Tree 1 5.5 m
555	321	307	316	432	427	445	234	208	178	119	102	80
560	330	317	326	447	439	475	238	210	197	118	100	81
565	339	325	334	462	450	489	239	219	208	114	99	79
570	347	330	341	473	461	487	244	230	213	113	99	79
575	356	337	351	485	472	492	257	239	220	115	97	78
580	364	346	359	497	480	493	269	247	231	115	99	77
585	369	352	364	504	485	486	275	254	238	117	100	77
590	369	352	367	511	492	508	276	260	240	121	100	79
595	371	353	369	514	496	509	278	262	248	122	100	78
600	375	357	372	521	503	518	286	275	249	129	101	82
605	376	360	373	524	505	521	295	278	253	133	103	83
610	378	362	374	526	506	520	295	279	261	135	106	85
615	378	362	375	520	502	513	304	284	262	138	106	86
620	380	367	378	521	502	518	313	289	272	151	108	88
625	400	381	397	500	419	359	256	226	213	172	155	151
630	373	356	380	508	467	364	201	181	169	138	114	117
635	392	363	403	606	661	375	241	207	167	116	96	102
640	361	336	351	416	390	276	189	182	151	107	85	91
645	233	213	179	258	129	164	102	144	121	85	85	81
650	177	162	141	222	107	148	87	136	109	86	86	90
655	155	143	131	197	106	146	83	138	115	89	91	99
660	148	136	129	182	108	147	85	135	119	95	98	97
665	143	131	128	179	110	151	85	133	118	100	101	98
670	135	120	104	170	94	126	83	140	87	84	78	91
675	124	109	92	165	85	121	80	144	79	73	68	73
680	119	101	86	163	78	115	77	145	79	73	68	73
685	116	100	81	159	85	112	77	145	84	74	67	74
690	109	96	75	153	82	106	76	144	73	73	70	74
695	110	91	74	148	79	108	76	142	73	75	68	65
700	106	92	77	145	78	111	77	139	79	70	64	75
705	115	101	100	147	96	124	86	149	90	88	82	85
710	127	115	114	153	110	139	86	145	110	108	105	124
715	128	117	114	156	109	137	85	140	109	105	102	122
720	128	113	108	157	104	130	88	142	101	93	93	93
725	118	103	87	154	92	118	89	141	87	80	77	81
730	121	104	93	150	96	119	86	140	89	79	79	80
735	123	103	92	146	93	115	87	137	88	85	81	84
740	118	100	90	141	90	114	86	138	85	75	75	77
745	117	100	89	139	89	116	87	135	87	74	74	76
750	118	102	89	136	97	116	88	134	90	83	85	82
755	118	98	82	137	90	114	88	134	87	79	77	84
760	116	101	87	138	95	112	87	134	85	83	81	88
765	113	98	84	140	90	106	89	134	83	82	80	83
770	111	98	86	141	92	110	89	134	87	75	74	82
775	116	100	84	143	97	112	91	136	88	80	79	83
780	121	102	88	146	95	112	91	138	88	79	80	86
785	118	101	79	150	91	110	92	138	80	82	76	82
790	119	100	85	152	99	115	91	139	90	77	77	80
795	125	101	78	157	92	108	94	141	79	75	74	77
800	127	102	82	162	97	115	95	142	85	78	83	82

Temperature measurements (°C) at location 2, 13.7 m from front of building, obtained during first test

Time (s)	Tree 2 Ceiling	Tree 2 0.3 m	Tree 2 0.6 m	Tree 2 0.9 m	Tree 2 1.2 m	Tree 2 1.5 m	Tree 2 1.8 m	Tree 2 2.7 m	Tree 2 3.3 m	Tree 2 4 m	Tree 2 4.6 m	Tree 2 5.5 m
-60	24	23	22	21	21	21	20	20	20	19	19	19
-55	24	23	22	22	21	21	20	20	20	19	19	18
-50	24	23	22	22	21	21	20	20	20	19	19	18
-45	24	23	22	22	21	21	20	20	20	19	19	18
-40	24	22	22	22	21	21	20	20	20	19	19	19
-35	24	23	22	21	21	21	20	20	20	19	19	19
-30	24	23	22	21	21	21	20	20	20	19	19	19
-25	24	23	22	21	21	21	20	20	20	19	19	19
-20	24	23	22	22	21	21	20	20	20	19	19	19
-15	24	23	22	22	21	21	20	20	20	19	19	19
-10	24	23	22	22	21	21	20	20	20	19	19	19
-5	24	23	22	22	21	21	20	20	20	19	19	19
0	24	23	22	22	21	21	20	20	20	19	19	19
5	24	23	22	22	21	21	20	20	22	26	19	19
10	24	23	22	22	21	21	22	22	25	29	19	19
15	24	23	22	21	21	21	23	23	27	32	19	19
20	23	23	23	21	22	22	25	24	27	33	19	19
25	24	24	25	25	24	23	29	30	33	39	19	19
30	26	27	28	28	27	26	25	29	38	37	19	19
35	28	30	30	31	28	26	27	27	37	39	19	20
40	29	31	33	35	31	29	33	32	40	46	19	20
45	30	34	36	37	32	30	33	31	36	51	19	20
50	32	36	38	38	35	33	33	32	36	56	20	20
55	33	38	38	39	37	33	33	33	35	60	22	21
60	34	38	39	42	38	34	33	35	35	64	23	21
65	36	40	42	43	39	37	41	38	53	75	22	23
70	39	44	47	44	41	41	52	52	51	93	22	24
75	42	46	48	48	45	44	58	52	64	119	23	27
80	44	51	55	60	52	55	71	71	85	144	26	31
85	52	59	63	66	64	66	84	89	82	170	28	32
90	58	65	76	74	65	66	80	77	74	155	29	30
95	63	76	84	81	72	73	84	85	67	168	29	32
100	69	83	91	90	79	81	87	88	68	247	34	34
105	70	90	102	91	85	88	101	97	83	286	37	41
110	83	98	107	103	100	99	110	104	118	298	39	46
115	91	106	119	119	112	110	125	113	121	303	42	45
120	93	114	133	133	123	127	139	125	127	367	43	52
125	93	129	140	139	138	142	153	143	165	347	48	54
130	97	142	154	149	146	157	171	156	169	333	52	54
135	104	144	157	163	157	165	160	162	143	381	57	58
140	110	157	174	185	164	203	171	166	202	398	77	61
145	116	175	191	262	180	316	194	184	228	367	96	67
150	130	194	218	303	221	273	212	181	277	232	102	81
155	130	201	214	204	188	180	160	154	145	197	113	93
160	146	223	231	250	240	200	166	152	175	278	147	106
165	166	253	269	286	274	240	189	159	168	251	194	131
170	188	289	318	327	302	277	214	165	190	328	216	142
175	217	346	408	406	371	316	219	164	167	297	216	147
180	289	463	537	530	470	391	246	174	216	348	243	170
185	364	577	672	779	721	532	275	209	276	338	254	180
190	610	674	703	730	809	739	362	261	290	332	274	222
195	773	763	754	752	763	803	528	392	520	361	299	239
200	777	756	771	768	793	759	799	800	789	416	308	257
205	662	668	667	664	667	657	657	659	634	467	323	278
210	642	636	633	650	639	635	630	635	604	665	378	307
215	631	624	640	663	632	668	647	622	633	756	452	356
220	695	700	764	708	688	725	696	698	714	744	630	378
225	709	725	705	694	690	694	670	700	680	691	646	397
230	683	690	694	714	693	677	701	690	685	698	670	460

Time (s)	Tree 2 Ceiling	Tree 2 0.3 m	Tree 2 0.6 m	Tree 2 0.9 m	Tree 2 1.2 m	Tree 2 1.5 m	Tree 2 1.8 m	Tree 2 2.7 m	Tree 2 3.3 m	Tree 2 4 m	Tree 2 4.6 m	Tree 2 5.5 m
235	687	682	690	709	698	691	712	701	687	731	718	520
240	682	675	667	675	675	677	695	695	675	706	711	564
245	666	665	656	660	658	666	675	674	658	674	656	534
250	653	649	644	647	645	654	651	650	643	650	646	522
255	622	614	611	614	610	624	619	611	610	612	584	440
260	600	592	589	593	591	603	601	592	588	593	570	445
265	573	564	563	567	563	577	574	565	561	560	517	388
270	547	539	536	541	536	551	549	541	535	533	485	402
275	524	517	513	519	514	530	527	521	514	512	460	338
280	502	495	489	495	491	504	503	498	492	477	424	324
285	476	468	463	467	464	474	475	469	464	437	381	299
290	447	439	436	439	437	445	445	439	434	402	352	268
295	418	410	409	409	406	414	417	407	404	366	291	248
300	391	384	384	383	380	387	390	380	375	336	284	236
305	367	362	363	360	358	363	366	356	351	311	265	225
310	346	343	343	339	339	342	344	334	330	290	246	214
315	327	326	325	322	321	324	325	316	311	270	233	204
320	310	311	310	305	305	308	308	299	293	255	227	194
325	296	297	296	292	293	295	293	285	279	246	214	189
330	284	286	284	281	281	283	280	273	267	233	208	182
335	273	276	274	271	272	273	269	262	256	229	196	178
340	265	267	265	262	263	264	260	254	248	226	190	172
345	257	259	257	255	256	257	252	246	240	220	185	169
350	250	252	250	249	249	250	244	238	231	213	182	165
355	244	246	244	242	243	244	238	232	225	209	178	162
360	238	241	239	237	238	238	233	226	221	201	174	159
365	233	235	234	232	232	233	228	221	216	198	172	155
370	228	231	229	227	228	229	223	215	209	193	167	150
375	224	226	224	223	223	224	217	211	204	189	164	148
380	220	222	220	218	219	219	211	206	200	181	163	147
385	215	218	215	214	215	215	206	203	194	176	161	142
390	212	214	211	211	212	212	202	199	192	175	159	138
395	209	211	208	208	209	208	199	196	187	173	157	134
400	205	208	205	206	206	205	195	193	183	170	156	135
405	203	205	202	203	203	202	192	189	181	168	152	133
410	200	203	200	200	200	200	190	188	179	166	149	130
415	198	200	197	198	198	197	187	184	177	164	147	128
420	196	199	195	197	196	196	186	182	176	160	146	126
425	194	197	194	195	195	194	184	180	175	154	144	123
430	193	196	192	194	193	193	183	179	171	154	142	122
435	191	194	191	192	192	191	182	177	170	153	140	121
440	190	193	189	191	191	190	181	175	169	151	139	120
445	189	192	188	190	190	189	181	175	168	150	137	118
450	188	191	187	190	189	187	179	174	165	147	136	117
455	187	190	186	189	188	187	177	172	163	147	133	116
460	186	190	186	189	188	186	177	172	164	147	132	115
465	186	189	185	189	188	186	177	171	165	145	131	114
470	186	189	185	189	188	186	177	171	163	145	131	113
475	186	189	185	188	187	186	177	172	162	145	130	112
480	187	190	185	189	188	187	176	171	161	143	128	111
485	187	190	186	190	189	187	177	171	162	142	128	110
490	190	193	188	193	192	189	177	171	159	140	126	110
495	192	196	190	195	194	190	178	171	162	138	125	109
500	192	196	190	195	194	190	178	171	163	138	124	107
505	193	197	190	195	193	192	178	172	162	138	124	107
510	195	199	192	198	196	194	180	173	165	137	123	107
515	198	203	195	201	200	197	183	174	162	134	121	106
520	201	206	198	204	202	200	184	175	166	135	116	82
525	203	208	199	206	204	201	185	177	161	137	119	98
530	205	211	202	209	207	205	187	179	169	135	117	92
535	207	213	203	210	208	206	188	180	166	130	115	87
540	208	214	205	211	209	207	189	180	165	129	115	82
545	209	216	206	213	211	209	190	181	169	125	114	77
550	211	218	208	215	213	211	193	183	168	126	112	71

Time (s)	Tree 2 Ceiling	Tree 2 0.3 m	Tree 2 0.6 m	Tree 2 0.9 m	Tree 2 1.2 m	Tree 2 1.5 m	Tree 2 1.8 m	Tree 2 2.7 m	Tree 2 3.3 m	Tree 2 4 m	Tree 2 4.6 m	Tree 2 5.5 m
555	213	220	210	217	215	214	191	182	165	126	108	69
560	216	224	213	220	218	217	192	182	170	126	106	71
565	220	227	216	224	221	220	194	184	173	126	106	79
570	223	229	218	227	224	223	197	187	183	127	105	76
575	227	234	223	231	228	228	201	192	184	130	102	78
580	233	240	228	237	234	234	207	197	193	140	101	77
585	238	245	233	241	238	239	212	202	200	134	102	78
590	241	249	236	245	242	242	215	206	201	148	101	76
595	244	252	240	248	245	245	220	212	205	152	105	76
600	248	255	243	251	248	249	224	217	213	165	104	78
605	253	259	249	257	253	255	229	229	227	166	106	80
610	258	264	254	261	258	260	235	232	234	180	116	82
615	261	267	257	264	261	262	241	235	235	203	115	79
620	265	271	261	268	265	266	244	240	238	204	119	84
625	255	257	247	254	241	228	167	174	161	147	111	83
630	231	231	219	230	219	208	154	148	132	113	84	76
635	219	220	208	223	212	205	166	156	142	122	81	75
640	217	221	206	226	217	212	177	169	158	135	75	75
645	223	230	213	235	226	223	203	188	171	148	86	75
650	231	243	226	245	236	236	210	198	177	155	90	75
655	244	258	243	259	248	252	228	210	195	165	97	76
660	259	275	266	276	262	271	272	236	207	178	110	78
665	266	280	269	278	265	272	278	246	225	191	105	78
670	265	276	263	274	262	266	245	226	215	174	87	79
675	261	271	256	269	259	260	239	222	207	116	89	79
680	257	268	252	266	256	257	223	211	180	98	84	79
685	254	265	248	263	253	255	210	196	172	107	79	79
690	251	263	245	260	249	252	219	192	167	98	78	80
695	247	260	239	256	246	248	216	187	156	103	75	80
700	226	229	212	219	222	214	191	214	203	173	157	93
705	187	187	179	178	174	159	176	136	125	128	160	83
710	171	171	164	163	158	155	163	137	131	142	161	83
715	160	160	155	154	149	150	154	132	125	146	157	84
720	151	152	147	146	142	143	147	126	119	130	151	85
725	140	139	137	134	127	122	141	111	104	119	145	86
730	131	131	130	128	121	115	136	103	101	117	145	86
735	125	126	125	124	117	114	132	102	99	113	139	87
740	122	123	123	122	115	112	128	109	102	112	135	88
745	120	121	120	120	114	111	126	105	103	113	140	88
750	117	119	119	119	112	110	123	105	103	111	144	88
755	116	118	117	117	111	109	121	105	103	110	143	89
760	114	114	116	115	108	105	119	105	97	116	137	89
765	113	113	114	53	109	107	117	104	100	115	136	89
770	108	25	113	27	108	105	27	27	26	28	30	30
775	111	112	114	114	107	106	-6999	105	1787	113	139	89
780	-6999	112	1906	114	-6999	106	-6999	108	416	119	140	-6999
785	-2718	24	1767	25	1085	25	25	104	97	26	141	1064
790	-6999	24	1409	115	1676	107	-6999	107	-6999	110	146	-6999
795	-6999	-6999	-6999	-6999	-6999	-6999	-6999	-6999	-6999	118	-6999	-6999
800	-6999	-6999	165	-5275	475	-6999	-6999	-6999	-6999	1194	-6999	-6999

Temperature measurements (°C) at location 3, 22.9 m from front of building, obtained during first test

Time (s)	Tree 3 Ceiling	Tree 3 0.3 m	Tree 3 0.6 m	Tree 3 0.9 m	Tree 3 1.5 m	Tree 3 2.1 m	Tree 3 2.7 m	Tree 3 3 m	Tree 3 3.3 m	Tree 3 4 m	Tree 3 4.6 m	Tree 3 5.5 m
-60	26	22	22	21	21	20	20	19	19	19	19	19
-55	25	22	22	21	21	20	20	19	19	19	19	19
-50	25	22	22	21	21	20	20	19	19	19	19	19
-45	26	22	22	21	21	20	20	19	19	19	19	19
-40	26	22	22	21	21	20	20	20	19	19	19	19
-35	25	22	22	21	21	20	20	20	19	19	19	19
-30	25	22	22	21	21	20	20	19	19	19	19	19
-25	25	22	22	21	21	20	20	19	19	19	19	19
-20	26	22	22	21	21	20	20	19	19	19	19	19
-15	26	22	22	21	21	20	20	20	20	19	19	19
-10	25	22	22	21	21	20	20	19	19	19	19	19
-5	26	22	22	21	21	20	20	20	19	19	19	19
0	25	22	22	21	21	20	20	20	19	19	19	19
5	26	22	22	21	21	20	20	20	19	19	19	19
10	25	22	22	21	21	20	20	19	19	19	19	19
15	25	22	22	21	21	20	20	20	19	19	19	19
20	26	22	22	21	21	20	20	19	19	19	19	19
25	25	22	22	21	21	20	20	20	19	19	19	19
30	24	22	22	21	21	20	20	20	20	19	19	19
35	24	24	23	22	22	21	20	20	20	19	19	19
40	24	23	24	24	23	21	20	20	20	19	19	19
45	25	25	26	25	24	21	21	20	20	19	19	19
50	26	27	27	27	27	21	21	20	20	19	19	19
55	28	28	30	30	28	21	21	21	20	19	19	19
60	30	30	30	31	31	22	21	21	21	20	19	19
65	32	31	32	32	32	24	24	23	22	20	19	19
70	33	33	34	34	33	26	27	25	23	20	20	19
75	34	34	34	35	34	27	27	26	23	21	20	19
80	35	34	35	36	35	30	29	28	26	21	20	19
85	37	37	39	39	37	32	30	30	28	21	20	19
90	40	40	42	45	39	33	32	32	30	22	20	19
95	45	46	48	51	49	34	36	34	33	22	20	19
100	53	54	57	58	56	38	39	38	37	24	20	19
105	58	61	62	65	62	46	45	43	39	26	21	20
110	62	66	71	72	61	53	50	47	41	27	22	20
115	73	73	76	78	80	58	57	53	48	31	22	20
120	77	80	83	87	85	66	65	61	54	33	25	22
125	86	88	92	94	89	74	72	68	65	36	27	22
130	95	94	102	107	99	83	82	78	70	42	30	21
135	104	111	113	116	110	95	90	85	75	50	34	22
140	113	119	120	126	123	104	99	91	80	56	38	21
145	121	124	129	132	128	110	106	102	89	66	44	21
150	126	128	136	139	138	121	111	108	99	74	52	21
155	136	139	145	150	147	124	120	113	106	82	58	25
160	147	151	152	159	155	135	126	121	115	90	61	34
165	144	152	162	171	173	147	137	132	127	99	70	37
170	177	180	187	193	189	152	149	142	132	110	79	39
175	191	197	204	220	219	166	163	154	142	114	86	46
180	234	242	260	270	253	185	181	172	160	124	96	56
185	298	304	331	341	340	219	203	187	182	132	103	65
190	382	421	460	476	460	272	251	240	206	143	120	75
195	416	460	502	547	524	365	313	289	246	160	140	87
200	460	543	621	650	645	447	378	352	310	200	165	96
205	494	665	630	678	727	542	450	406	350	241	200	110
210	643	658	660	658	650	531	480	455	410	301	239	120
215	592	599	606	604	595	516	456	436	412	343	257	127
220	574	578	584	585	575	501	445	423	403	354	269	139
225	563	566	571	571	563	488	424	419	398	351	291	157
230	546	547	551	551	546	471	419	399	374	345	292	175

Time (s)	Tree 3 Ceiling	Tree 3 0.3 m	Tree 3 0.6 m	Tree 3 0.9 m	Tree 3 1.5 m	Tree 3 2.1 m	Tree 3 2.7 m	Tree 3 3 m	Tree 3 3.3 m	Tree 3 4 m	Tree 3 4.6 m	Tree 3 5.5 m
235	530	532	536	536	531	464	423	413	385	353	305	190
240	513	516	520	521	513	448	417	407	381	352	317	201
245	500	502	506	506	499	448	423	411	392	365	318	216
250	480	484	488	487	476	425	410	399	385	353	313	224
255	463	467	470	469	463	416	395	385	373	349	312	231
260	448	451	454	453	449	404	384	372	357	324	290	222
265	433	436	438	437	433	385	368	357	344	305	278	218
270	416	421	423	421	417	376	358	345	336	304	272	214
275	403	407	409	408	403	365	339	332	321	287	259	210
280	391	395	397	395	393	353	331	319	305	273	251	198
285	376	381	382	381	374	337	320	303	287	258	244	198
290	366	370	372	371	370	330	310	299	278	250	229	188
295	353	359	361	359	348	317	301	289	269	241	224	183
300	344	349	351	350	341	309	291	277	261	232	222	178
305	333	337	340	339	331	302	284	267	254	224	207	172
310	323	327	329	328	316	290	272	257	247	218	199	168
315	312	317	320	319	305	283	262	252	243	214	195	163
320	304	309	311	310	297	276	257	246	233	206	190	159
325	294	298	301	299	291	269	252	242	226	199	185	155
330	285	292	294	293	285	262	245	236	219	195	182	152
335	279	285	287	286	278	254	240	228	213	190	177	147
340	272	279	281	280	269	251	237	222	206	186	173	143
345	266	272	274	272	265	246	232	216	199	183	171	143
350	260	266	268	267	262	242	227	211	196	178	169	141
355	255	261	264	264	255	238	222	208	191	174	166	136
360	252	259	261	260	255	235	218	206	188	171	162	133
365	247	252	256	256	247	229	214	203	185	167	159	130
370	243	250	253	253	243	227	210	197	182	165	157	128
375	240	243	248	250	239	225	209	193	178	163	155	126
380	236	243	246	245	234	221	204	191	177	160	153	124
385	233	236	242	242	235	219	204	190	173	157	152	122
390	229	236	239	239	229	215	199	186	170	155	149	122
395	227	234	236	238	225	212	195	186	171	155	146	119
400	225	231	233	237	224	211	194	182	167	152	144	118
405	225	230	235	236	223	210	193	179	165	150	143	116
410	222	230	233	234	222	208	190	177	163	148	141	113
415	221	226	231	232	220	207	189	177	164	148	140	111
420	221	227	231	232	218	207	188	174	160	146	137	109
425	222	227	231	233	220	205	189	175	161	146	136	108
430	222	228	233	236	217	205	187	172	159	144	135	106
435	223	228	235	237	218	206	185	170	161	143	133	104
440	222	229	235	235	217	205	183	168	159	143	132	104
445	225	231	235	238	217	206	181	165	157	142	131	101
450	225	230	234	235	217	206	182	164	157	140	129	102
455	225	231	236	235	219	208	181	163	156	139	128	101
460	224	231	235	236	220	208	183	164	155	139	128	101
465	224	232	236	238	218	208	182	165	155	137	127	99
470	227	233	240	244	221	208	183	166	155	137	127	99
475	227	234	241	246	221	209	184	165	155	137	126	98
480	226	236	242	246	228	209	183	164	155	136	125	97
485	228	236	242	248	226	211	183	166	155	137	125	97
490	233	241	248	257	229	214	186	167	154	136	124	96
495	245	252	263	270	231	214	187	170	155	137	123	94
500	255	264	274	279	238	218	188	170	156	136	123	94
505	254	260	272	273	251	224	185	164	156	136	122	94
510	256	261	271	274	253	225	185	168	157	137	122	93
515	260	267	282	284	265	233	190	172	158	138	121	91
520	268	279	290	299	260	237	192	177	160	139	120	91
525	271	284	297	305	266	240	195	172	160	136	116	91
530	278	297	306	315	273	242	194	175	160	133	112	87
535	282	300	304	311	276	245	196	177	161	136	110	86
540	291	307	315	322	281	249	203	178	160	129	107	85
545	292	307	316	323	282	243	199	179	162	129	106	83
550	293	309	315	321	279	250	201	178	160	128	105	79

Time (s)	Tree 3 Ceiling	Tree 3 0.3 m	Tree 3 0.6 m	Tree 3 0.9 m	Tree 3 1.5 m	Tree 3 2.1 m	Tree 3 2.7 m	Tree 3 3 m	Tree 3 3.3 m	Tree 3 4 m	Tree 3 4.6 m	Tree 3 5.5 m
555	295	314	320	330	286	251	205	180	159	126	102	76
560	301	319	324	339	289	258	205	181	158	124	101	79
565	308	325	332	342	299	259	210	186	160	124	99	77
570	314	331	340	346	309	265	208	187	162	124	98	75
575	321	336	344	354	319	269	213	192	165	125	98	75
580	328	347	356	369	315	278	220	198	168	128	98	75
585	343	359	370	379	326	288	228	204	173	130	99	75
590	348	365	373	383	332	295	227	206	179	133	101	75
595	352	367	374	383	339	296	232	208	184	136	102	74
600	355	370	377	384	337	300	239	212	187	137	103	73
605	356	367	378	382	345	301	243	216	192	140	104	75
610	360	373	381	384	343	304	249	220	196	144	106	75
615	361	375	381	386	344	312	252	223	199	147	107	75
620	365	379	386	391	351	315	254	228	204	150	109	74
625	361	373	380	386	344	309	244	222	196	143	102	72
630	378	393	405	417	431	333	278	246	212	160	112	78
635	432	450	463	473	438	368	308	277	242	187	118	80
640	465	472	478	482	467	430	365	333	265	190	142	87
645	485	493	497	501	497	428	391	352	297	236	167	90
650	497	502	504	506	508	429	390	371	331	260	188	95
655	507	512	515	517	518	453	405	385	346	274	216	103
660	517	522	525	525	524	446	407	396	370	301	241	119
665	516	520	522	523	521	464	417	401	374	313	256	138
670	500	505	509	507	502	440	405	392	375	314	266	157
675	487	493	497	496	489	438	400	391	370	317	270	169
680	473	477	482	483	469	412	390	380	369	315	266	170
685	458	466	471	470	455	405	376	365	347	297	263	161
690	447	457	462	463	456	400	374	361	334	290	254	157
695	441	452	456	457	445	390	367	352	320	283	245	149
700	436	446	454	456	435	387	366	352	320	273	230	143
705	471	484	490	501	506	439	383	365	336	280	233	148
710	497	503	507	511	499	445	413	392	368	317	265	157
715	505	512	514	516	510	467	440	419	389	338	270	173
720	509	515	519	523	509	464	431	421	396	357	296	178
725	511	517	521	522	507	463	431	417	398	365	304	192
730	511	517	520	520	510	484	435	413	400	366	309	197
735	508	515	519	519	503	449	419	406	390	359	309	208
740	512	520	523	525	515	461	428	409	398	356	312	204
745	516	523	525	526	516	469	435	416	403	367	319	215
750	522	529	531	532	515	467	445	422	402	361	319	221
755	517	523	525	524	511	470	442	425	419	379	329	222
760	507	514	516	518	506	461	438	424	399	361	319	215
765	503	510	513	512	498	462	431	420	399	370	325	215
770	505	510	513	514	502	471	439	434	409	368	322	221
775	506	513	515	517	507	465	437	428	401	371	327	222
780	509	517	518	521	514	475	436	425	409	366	324	225
785	514	521	523	525	517	469	447	429	409	379	324	229
790	515	523	524	525	515	475	438	430	414	369	326	227
795	518	526	527	530	518	477	449	440	426	381	323	226
800	522	529	532	533	519	470	440	428	416	381	327	234

Temperature measurements (°C) and carbon monoxide volume fractions (%) at a location 15 m from front wall and 6.1 m from the east wall obtained during first test

Time (s)	0.9 m above Floor		0.025 m above Floor	
	Temperature (°C)	CO (%)	Temperature (°C)	CO (%)
-60	18	-0.01	18	-0.11
-55	18	0.00	19	-0.12
-50	18	0.00	19	-0.12
-45	19	0.00	19	-0.12
-40	19	-0.01	18	-0.12
-35	19	0.00	19	-0.12
-30	19	0.00	19	-0.12
-25	19	-0.01	19	-0.12
-20	19	-0.01	19	-0.12
-15	19	-0.01	19	-0.12
-10	19	-0.01	19	-0.12
-5	19	0.00	19	-0.12
0	19	-0.01	18	-0.12
5	19	-0.01	19	-0.12
10	19	0.00	19	-0.12
15	19	0.00	19	-0.12
20	19	0.01	19	-0.12
25	19	0.00	19	-0.12
30	19	0.00	20	-0.12
35	19	0.00	20	-0.12
40	19	0.00	20	-0.12
45	19	0.00	20	-0.12
50	20	0.00	20	-0.12
55	20	-0.01	20	-0.12
60	20	0.00	21	-0.12
65	21	0.00	22	-0.12
70	23	0.00	23	-0.12
75	23	0.01	25	-0.12
80	24	0.00	27	-0.12
85	25	0.00	29	-0.12
90	25	0.00	29	-0.12
95	26	0.00	31	-0.12
100	29	0.01	34	-0.12
105	33	0.00	37	-0.12
110	35	0.00	41	-0.12
115	37	0.00	44	-0.12
120	39	0.00	46	-0.12
125	43	-0.01	47	-0.12
130	44	-0.01	49	-0.12
135	48	-0.01	51	-0.12
140	51	-0.01	51	-0.12
145	52	0.01	54	-0.12
150	52	0.00	55	-0.12
155	51	0.01	53	-0.12
160	60	0.01	53	-0.12
165	62	0.00	58	-0.12
170	79	0.00	61	-0.12
175	95	-0.01	65	-0.12
180	126	-0.08	66	-0.12
185	145	-0.03	59	-0.11
190	153	-0.01	61	-0.12
195	182	0.01	65	-0.12
200	185	0.02	68	-0.11
205	192	0.02	75	-0.11
210	143	0.01	94	-0.10
215	174	0.01	104	-0.09
220	208	0.01	108	-0.09
225	260	0.01	111	-0.08
230	237	0.03	109	-0.08

Time (s)	0.9 m above Floor		0.025 m above Floor	
	Temperature (°C)	CO (%)	Temperature (°C)	CO (%)
235	195	0.04	114	-0.07
240	188	0.04	124	-0.07
245	231	0.06	128	-0.04
250	281	0.10	121	0.02
255	260	0.14	109	0.14
260	201	0.20	107	0.28
265	173	0.40	106	0.41
270	213	0.73	109	0.66
275	192	0.90	104	1.23
280	166	0.91	100	1.96
285	156	1.03	95	2.44
290	144	1.42	94	2.57
295	131	1.75	97	2.83
300	126	1.83	103	3.05
305	129	1.94	96	3.15
310	140	2.30	87	3.11
315	139	2.90	84	3.02
320	132	3.21	84	2.97
325	139	3.48	84	2.98
330	138	3.42	84	3.05
335	132	3.26	82	3.18
340	127	3.20	80	3.37
345	125	3.26	78	3.59
350	123	3.39	77	3.79
355	121	3.48	76	3.96
360	119	3.51	76	4.08
365	117	3.49	75	4.17
370	114	3.48	76	4.20
375	113	3.48	73	4.21
380	113	3.55	71	4.18
385	110	3.60	70	4.14
390	106	3.57	72	4.19
395	107	3.52	74	4.21
400	103	3.44	73	4.13
405	101	3.41	72	4.03
410	103	3.40	71	3.95
415	104	3.39	69	3.87
420	103	3.39	68	3.80
425	102	3.33	68	3.75
430	102	3.27	67	3.71
435	98	3.24	67	3.67
440	97	3.21	66	3.64
445	98	3.19	64	3.62
450	98	3.20	63	3.61
455	97	3.19	63	3.59
460	96	3.16	62	3.57
465	96	3.11	64	3.55
470	95	3.06	63	3.53
475	94	3.03	63	3.52
480	94	3.01	63	3.54
485	93	3.01	64	3.59
490	94	3.04	62	3.61
495	93	3.02	62	3.60
500	92	3.04	61	3.60
505	93	3.07	60	3.56
510	91	3.09	59	3.51
515	83	3.03	60	3.44
520	74	2.99	60	3.39
525	77	2.97	52	3.39
530	76	2.94	46	3.42
535	72	2.90	46	3.45
540	69	2.71	42	3.40
545	65	2.04	45	3.17
550	63	1.40	43	2.86

Time (s)	0.9 m above Floor		0.025 m above Floor	
	Temperature (°C)	CO (%)	Temperature (°C)	CO (%)
555	64	0.87	41	2.56
560	63	0.63	44	2.21
565	63	0.54	43	2.01
570	60	0.51	41	1.82
575	63	0.52	41	1.64
580	62	0.47	42	1.48
585	68	0.45	44	1.35
590	63	0.45	45	1.27
595	63	0.39	45	1.18
600	62	0.37	47	1.13
605	64	0.23	43	1.10
610	62	0.31	42	1.08
615	61	0.39	40	1.02
620	111	0.40	54	0.94
625	142	0.42	55	0.87
630	100	0.40	54	0.83
635	110	0.34	52	0.80
640	123	0.27	52	0.73
645	122	0.44	51	0.76
650	134	1.02	50	1.05
655	143	1.55	50	1.34
660	155	2.03	50	1.59
665	146	2.02	50	1.89
670	114	2.06	50	2.14
675	104	2.10	49	2.29
680	104	2.16	49	2.30
685	101	2.21	49	2.21
690	95	2.25	49	2.15
695	96	2.24	49	2.09
700	134	2.21	49	1.91
705	140	2.11	48	1.65
710	153	1.78	48	1.36
715	163	1.35	49	1.11
720	146	1.04	48	0.92
725	121	0.94	48	0.79
730	119	0.98	48	0.85
735	118	1.01	48	1.25
740	134	1.01	48	1.91
745	143	1.01	48	2.51
750	132	1.08	48	1.57
755	132	1.21	48	2.06
760	128	1.28	48	1.89
765	122	1.30	48	1.67
770	128	1.26	48	1.66
775	118	1.18	47	1.77
780	122	1.11	48	1.79
785	129	1.06	47	1.69
790	133	1.03	47	1.56
795	126	1.01	47	1.44
800	121	0.99	47	1.32

Appendix B

Temperature measurements (°C) at location 4, 32 m from front of building, obtained during second test

Time (s)	Tree 4 Ceiling	Tree 4 0.3 m	Tree 4 0.6 m	Tree 4 0.9 m	Tree 4 1.5 m	Tree 4 2.1 m	Tree 4 2.7 m	Tree 4 3 m	Tree 4 3.3 m	Tree 4 4 m	Tree 4 4.6 m	Tree 4 5.5 m
-60	34	29	29	29	28	24	23	22	22	21	21	21
-55	35	29	28	29	28	24	24	22	22	21	21	22
-50	34	29	29	29	28	25	23	22	23	21	21	22
-45	35	29	29	29	28	25	24	22	22	22	21	22
-40	33	30	28	29	28	25	23	22	23	21	21	22
-35	34	29	29	29	27	25	23	22	22	22	21	21
-30	34	29	29	29	27	25	23	22	22	21	21	22
-25	34	29	28	29	28	24	24	23	22	21	21	21
-20	33	30	29	29	29	25	23	23	22	21	21	21
-15	33	29	29	29	27	25	23	22	22	21	21	21
-10	34	29	28	29	27	23	24	22	22	21	21	22
-5	33	30	29	29	28	23	23	22	22	21	21	22
0	35	30	30	32	27	24	24	22	22	22	21	22
5	35	34	33	35	33	25	24	22	22	22	21	22
10	33	34	36	39	34	24	24	22	23	22	21	22
15	35	35	37	39	36	24	23	22	23	21	21	22
20	36	37	38	40	44	31	24	22	22	22	21	22
25	41	46	53	56	49	30	25	22	23	22	22	22
30	57	65	71	68	61	28	26	23	23	23	22	22
35	77	98	95	96	85	40	28	25	24	23	22	22
40	108	124	127	128	105	56	35	30	24	24	22	23
45	126	147	144	137	125	67	40	28	25	24	23	24
50	149	164	166	168	128	86	35	26	25	26	23	24
55	163	179	184	188	171	99	36	27	28	26	23	24
60	170	184	194	201	192	113	40	32	29	26	24	25
65	170	186	190	194	187	109	47	34	29	26	24	24
70	167	187	190	191	185	119	52	35	30	26	24	24
75	175	202	206	206	180	121	55	37	31	26	23	24
80	172	204	207	207	196	134	56	42	32	26	24	24
85	181	202	201	208	196	141	67	44	34	27	25	24
90	181	209	211	214	211	120	71	48	36	27	25	24
95	187	206	215	218	203	138	73	48	36	28	25	24
100	188	215	224	229	212	139	73	55	38	29	25	24
105	200	219	224	226	208	160	74	57	42	31	26	25
110	209	229	235	237	223	162	77	56	44	31	25	26
115	203	228	233	234	217	160	82	58	46	31	26	26
120	211	237	241	239	219	171	85	67	45	31	28	25
125	207	235	241	247	243	183	93	76	45	30	29	26
130	220	249	250	252	229	175	99	82	48	32	29	28
135	215	262	261	274	262	171	101	86	49	34	29	29
140	235	280	286	279	274	186	106	89	51	34	27	26
145	267	294	305	307	283	217	110	95	71	30	26	27
150	274	333	333	343	322	210	117	102	71	35	28	29
155	289	345	357	373	357	214	131	114	79	41	33	32
160	307	335	373	386	388	322	142	120	94	48	39	34
165	373	439	470	501	444	306	150	130	107	54	44	34
170	553	725	808	733	538	295	180	149	127	63	48	34
175	740	758	742	801	736	362	215	186	160	90	59	39
180	754	760	752	772	817	518	273	235	203	132	80	45
185	776	766	775	792	792	709	359	294	258	168	106	56
190	758	749	755	768	757	733	539	346	309	193	132	74
195	773	780	777	800	780	762	603	449	375	246	170	82
200	787	797	795	759	758	735	610	610	421	298	192	84
205	713	730	748	727	786	727	565	568	634	334	234	86
210	730	743	738	769	767	690	594	582	575	347	291	91
215	737	727	763	824	832	692	616	555	532	390	331	102
220	727	748	707	831	832	697	640	563	521	434	343	118
225	662	664	684	772	819	719	601	547	501	413	320	95
230	586	605	673	772	799	698	545	513	474	377	320	88

Time (s)	Tree 4 Ceiling	Tree 4 0.3 m	Tree 4 0.6 m	Tree 4 0.9 m	Tree 4 1.5 m	Tree 4 2.1 m	Tree 4 2.7 m	Tree 4 3 m	Tree 4 3.3 m	Tree 4 4 m	Tree 4 4.6 m	Tree 4 5.5 m
235	586	600	683	771	795	646	531	492	455	386	303	92
240	596	598	690	772	793	620	504	473	438	364	300	101
245	596	593	686	756	773	587	493	471	430	371	284	104
250	594	590	676	737	752	587	480	457	430	360	283	113
255	592	587	674	729	743	594	482	462	436	359	296	121
260	595	590	677	732	748	578	474	466	428	354	296	117
265	612	604	697	757	774	605	483	467	436	384	307	125
270	618	611	709	768	784	603	487	469	441	383	336	121
275	623	614	714	771	791	662	497	480	447	385	333	126
280	623	614	714	768	786	610	487	475	442	382	332	133
285	624	615	713	767	780	602	496	467	446	383	331	135
290	633	625	723	780	796	691	499	479	453	386	345	139
295	647	637	740	800	817	657	505	487	457	397	341	153
300	650	639	743	807	825	647	521	493	469	412	339	161
305	650	639	747	802	819	640	526	505	467	417	366	156
310	655	643	747	802	818	614	518	506	476	415	363	168
315	644	630	730	783	798	616	525	512	479	422	358	167
320	633	623	713	757	771	623	535	519	498	430	364	173
325	618	610	692	730	742	605	525	514	487	443	366	188
330	604	598	670	706	716	589	520	506	474	430	372	184
335	588	584	649	681	692	579	511	503	475	428	368	199
340	582	578	639	671	682	574	520	504	474	422	360	216
345	580	577	637	668	680	578	528	515	488	432	368	226
350	575	572	630	659	669	576	536	514	493	438	366	207
355	570	568	621	648	659	570	528	515	494	439	365	217
360	568	566	618	645	655	571	517	509	487	435	378	240
365	568	566	617	644	657	580	531	517	496	446	373	262
370	570	568	619	646	656	577	537	521	502	457	398	242
375	562	562	607	631	638	560	551	536	511	468	410	251
380	556	556	596	618	626	555	540	532	515	477	414	271
385	556	556	593	614	624	564	541	540	517	486	429	296
390	560	560	594	615	625	581	568	574	558	509	461	299
395	558	559	590	610	619	568	553	549	535	496	452	299
400	555	555	585	604	613	562	548	543	524	495	463	336
405	557	557	586	605	616	570	556	552	534	501	473	357
410	557	557	587	608	617	567	556	550	537	501	456	348
415	550	552	578	596	604	552	545	541	527	496	464	371
420	555	556	580	599	607	576	570	566	551	531	475	385
425	560	562	589	610	618	573	550	534	513	488	446	370
430	567	567	598	622	632	595	577	566	538	504	452	386
435	581	580	614	644	656	593	579	568	542	499	459	388
440	587	586	623	652	664	613	596	590	563	528	477	382
445	585	586	624	651	660	607	581	572	555	517	474	407
450	593	594	628	655	664	610	597	599	580	548	501	398
455	619	619	640	662	670	665	692	767	770	839	809	814
460	641	647	657	658	663	655	659	659	658	669	640	537
465	639	635	640	635	643	626	639	629	640	638	617	569
470	631	629	634	639	646	633	651	675	641	644	654	686
475	626	649	669	676	643	662	673	680	599	685	601	237
480	691	551	691	636	38	566	424	472	516	712	577	426
485	718	509	727	465	113	565	385	542	566	760	566	599
490	681	485	651	485	131	549	367	503	546	671	244	238
495	655	480	627	293	260	265	261	494	267	223	254	357
500	615	607	614	292	251	272	266	473	273	224	298	350
505	644	640	653	303	278	290	279	501	291	585	215	619
510	667	659	665	311	286	303	290	516	302	600	220	265
515	668	518	658	323	292	300	294	525	295	295	227	324
520	668	522	668	290	275	258	308	530	255	264	270	260
525	592	519	683	293	265	250	344	538	251	235	288	206
530	508	669	633	312	263	256	529	522	255	233	292	205
535	478	232	623	296	274	263	353	493	260	237	292	219
540	434	223	549	313	276	291	313	448	266	246	292	255
545	228	20	429	306	259	266	238	251	82	238	276	243
550	425	226	481	313	278	306	271	441	269	236	286	237

Time (s)	Tree 4 Ceiling	Tree 4 0.3 m	Tree 4 0.6 m	Tree 4 0.9 m	Tree 4 1.5 m	Tree 4 2.1 m	Tree 4 2.7 m	Tree 4 3 m	Tree 4 3.3 m	Tree 4 4 m	Tree 4 4.6 m	Tree 4 5.5 m
555	417	226	449	313	278	305	292	429	270	235	285	253
560	322	229	451	312	277	300	261	411	274	245	276	259
565	274	230	477	308	276	298	264	440	273	233	275	278
570	275	231	483	309	278	299	277	465	273	239	275	262
575	278	232	466	320	281	286	280	439	282	234	289	262
580	280	248	511	289	287	267	263	465	285	250	300	264
585	289	489	522	295	288	333	318	481	298	228	326	270
590	528	502	641	324	287	314	247	530	298	247	326	278
595	470	511	459	299	315	387	315	571	311	223	396	365
600	720	427	637	410	376	237	235	551	469	208	453	436
605	725	755	554	203	398	576	630	731	713	704	735	735
610	756	858	886	207	832	794	875	593	733	648	623	577
615	759	814	872	434	823	811	841	786	392	768	663	632
620	722	294	617	705	671	638	686	609	422	518	638	400
625	435	290	854	445	665	727	812	662	572	663	680	410
630	709	288	521	643	771	564	420	769	462	94	641	606
635	754	270	502	703	791	616	406	788	555	131	655	636
640	708	292	415	650	745	635	359	804	573	361	569	569
645	656	279	569	670	655	607	347	746	626	435	533	544
650	644	282	504	638	641	669	336	710	607	423	499	529
655	630	271	372	620	574	512	296	695	620	613	465	581
660	587	266	321	562	510	538	340	659	619	548	445	528
665	524	271	329	492	509	520	276	573	550	447	448	478
670	477	269	335	458	503	487	272	515	500	458	458	442
675	453	269	324	406	476	478	274	463	469	470	424	439
680	449	269	326	391	472	472	271	440	451	468	415	435
685	425	268	362	424	477	461	270	424	428	471	423	427
690	436	269	324	372	467	460	270	408	429	481	406	434
695	439	269	320	367	472	464	275	405	426	484	404	435
700	428	270	329	368	474	455	279	411	417	483	398	423
705	413	271	264	376	465	445	278	398	406	186	365	415
710	433	269	172	392	480	457	445	406	455	190	379	312
715	422	270	189	378	448	443	429	398	440	193	358	311
720	435	272	191	379	446	448	426	416	438	185	369	311
725	450	271	171	393	460	455	443	440	438	192	380	313
730	458	272	173	400	444	452	434	451	441	195	378	321
735	454	271	162	401	441	453	434	455	429	204	377	432
740	472	271	171	411	447	462	417	468	440	191	393	441
745	472	273	172	413	446	467	413	481	447	187	399	441
750	443	272	185	400	442	456	405	456	433	200	379	432
755	453	271	191	400	440	465	477	462	438	198	383	437
760	454	272	194	401	435	468	482	463	440	188	388	438
765	442	273	195	394	430	462	474	450	433	193	386	436
770	445	273	195	385	430	462	461	442	428	194	385	434

Temperature measurements (°C) at location 5, 36.6 m from front of building, obtained during second test

Time (s)	Tree 5 Ceiling	Tree 5 0.3 m	Tree 5 0.6 m	Tree 5 0.9 m	Tree 5 1.5 m	Tree 5 2.1 m	Tree 5 2.7 m	Tree 5 3 m	Tree 5 3.3 m	Tree 5 4 m	Tree 5 4.6 m	Tree 5 5.5 m
-60	28	30	29	28	25	23	22	22	22	21	21	21
-55	28	30	29	28	26	23	22	22	21	21	21	21
-50	28	29	29	28	26	24	22	22	21	21	21	21
-45	28	30	29	28	26	24	22	22	22	21	21	21
-40	28	30	29	28	26	23	22	22	22	21	21	21
-35	28	30	28	28	25	23	22	22	22	21	21	21
-30	28	30	28	28	26	23	22	22	22	21	21	21
-25	28	30	29	28	25	23	22	22	22	21	21	21
-20	28	30	29	28	26	23	22	22	22	21	21	21
-15	28	29	29	28	25	23	22	22	22	21	21	21
-10	28	29	29	28	25	23	22	22	22	21	21	21
-5	28	29	29	28	25	23	22	22	22	21	21	21
0	28	30	30	29	27	24	23	22	22	21	21	21
5	29	34	35	36	32	28	23	22	22	22	21	21
10	30	37	38	39	34	25	23	22	22	21	21	21
15	30	38	39	40	39	29	23	22	22	21	21	21
20	30	39	41	42	48	35	24	22	22	22	21	21
25	35	56	57	61	63	29	24	22	22	22	21	21
30	35	60	66	71	67	30	23	22	22	22	22	22
35	36	68	77	89	81	39	24	23	23	22	22	22
40	42	108	114	119	119	56	24	24	23	23	22	22
45	50	121	133	138	117	61	29	25	24	23	22	23
50	58	153	160	158	121	72	34	30	26	24	23	23
55	58	171	179	175	124	85	38	32	28	25	23	23
60	67	172	175	177	142	85	41	35	28	25	23	23
65	58	156	167	163	145	105	44	35	30	25	23	23
70	62	169	166	171	144	101	51	33	30	26	24	23
75	65	168	170	169	156	106	60	35	32	27	24	23
80	71	175	175	176	160	112	62	37	33	27	24	23
85	70	183	185	182	158	117	61	39	34	27	24	24
90	72	176	181	182	175	119	70	41	34	26	25	24
95	69	173	180	182	177	118	76	45	34	26	25	24
100	72	180	180	185	179	135	79	48	35	26	24	25
105	71	182	181	184	186	143	83	55	37	27	24	25
110	79	184	188	192	188	134	84	62	38	27	25	25
115	76	190	195	195	195	149	88	66	41	28	26	25
120	78	188	198	200	203	152	93	70	40	29	26	26
125	79	201	206	207	203	153	93	75	46	30	26	26
130	85	203	210	213	210	164	100	82	49	32	26	26
135	88	213	219	221	220	177	102	86	61	33	27	26
140	89	225	229	232	220	170	104	87	67	34	27	27
145	100	236	244	247	235	186	104	86	72	34	27	27
150	106	248	259	264	260	204	109	92	77	36	28	28
155	113	273	275	289	288	223	126	104	84	39	30	29
160	129	295	302	317	307	249	141	114	80	43	32	30
165	144	349	362	386	364	264	161	130	97	46	33	31
170	170	464	508	515	401	262	187	150	118	54	36	33
175	201	663	728	729	518	345	214	177	149	75	41	37
180	652	723	731	754	763	459	276	234	185	115	50	45
185	745	763	755	758	759	628	342	288	241	174	76	55
190	732	726	747	731	725	701	391	351	292	222	105	65
195	749	743	724	767	742	686	454	385	339	271	135	76
200	720	748	771	712	739	703	492	407	363	303	171	78
205	670	686	751	668	683	654	490	428	387	332	192	85
210	654	659	737	653	666	639	521	470	413	346	234	94
215	668	660	730	664	676	669	550	515	440	333	267	103
220	659	650	693	658	668	649	551	510	464	351	282	121
225	611	609	645	616	623	600	530	505	466	396	291	116
230	580	580	614	587	592	570	499	475	444	375	294	109

Time (s)	Tree 5 Ceiling	Tree 5 0.3 m	Tree 5 0.6 m	Tree 5 0.9 m	Tree 5 1.5 m	Tree 5 2.1 m	Tree 5 2.7 m	Tree 5 3 m	Tree 5 3.3 m	Tree 5 4 m	Tree 5 4.6 m	Tree 5 5.5 m
235	556	556	592	563	568	547	474	444	414	347	281	104
240	544	544	580	550	555	538	468	450	410	344	272	107
245	532	532	567	538	542	528	465	447	415	341	266	107
250	524	524	559	530	534	517	446	432	411	339	251	103
255	520	521	555	526	529	518	444	422	403	333	269	102
260	521	523	557	527	530	518	444	422	392	331	267	105
265	526	527	561	531	535	525	456	432	401	330	281	118
270	534	535	569	540	543	531	474	449	418	340	302	129
275	536	537	570	542	545	531	474	452	426	350	310	137
280	537	539	571	543	546	539	476	445	427	359	313	138
285	539	539	572	544	548	536	474	446	422	362	311	153
290	546	547	573	549	551	542	478	453	428	376	335	162
295	545	546	573	549	552	543	475	445	420	369	339	177
300	548	549	577	553	555	550	484	464	422	371	341	182
305	550	551	577	555	556	547	489	479	423	389	351	183
310	550	550	578	554	557	546	487	467	439	387	353	192
315	550	551	578	555	557	549	484	473	442	400	364	200
320	559	558	585	563	565	557	504	487	478	411	348	208
325	559	559	585	563	566	557	512	498	478	427	354	222
330	566	567	591	570	573	567	518	488	469	434	372	223
335	565	566	591	570	573	563	504	488	470	440	369	220
340	564	564	591	569	572	564	495	491	480	436	374	225
345	571	572	596	576	578	568	525	503	487	440	372	231
350	573	574	598	578	580	569	527	497	483	457	397	240
355	570	571	596	575	577	567	509	496	481	463	406	245
360	572	573	599	577	580	576	529	498	483	461	387	244
365	582	583	605	586	588	582	532	515	490	456	387	248
370	588	588	608	592	593	586	541	516	502	469	408	268
375	591	592	612	596	597	590	548	522	505	476	415	270
380	600	601	620	605	607	599	564	534	515	482	410	277
385	613	614	631	617	619	611	576	543	521	490	441	317
390	610	612	629	615	617	607	579	548	532	498	457	325
395	609	610	627	613	615	605	587	569	547	503	462	338
400	601	602	621	605	608	597	569	553	541	499	464	359
405	616	617	632	619	620	613	579	565	550	504	465	360
410	608	608	626	612	614	607	576	561	549	514	476	372
415	597	597	614	601	603	594	572	557	552	520	479	388
420	602	604	620	607	609	607	586	571	554	514	487	396
425	605	606	625	610	611	603	570	550	537	510	481	398
430	608	609	626	612	614	610	589	571	547	507	473	395
435	609	609	624	613	613	605	573	548	536	508	467	401
440	600	599	615	604	605	605	594	569	540	507	466	389
445	594	594	607	598	599	593	580	571	555	504	471	404
450	601	601	610	603	604	600	592	586	569	506	466	406
455	603	603	611	605	606	602	597	592	590	529	466	406
460	596	596	603	599	598	594	586	581	575	519	458	402
465	574	573	581	576	577	571	561	552	542	507	465	407
470	564	564	572	567	568	563	560	551	539	497	462	406
475	566	565	571	567	568	566	565	560	551	519	473	399
480	554	554	561	557	558	554	547	538	526	495	466	395
485	550	549	556	552	552	549	544	536	525	487	455	382
490	550	550	556	553	553	551	556	549	535	487	459	387
495	543	543	549	545	545	541	535	528	521	489	463	396
500	542	543	548	545	545	543	544	537	531	500	463	388
505	540	541	546	543	543	541	542	535	530	505	457	385
510	542	543	547	545	545	544	547	542	535	508	453	381
515	542	543	547	545	545	542	548	544	540	518	465	386
520	539	540	544	542	541	541	542	536	532	515	470	388
525	543	544	548	545	545	547	556	550	543	522	472	402
530	542	544	546	545	544	541	539	535	528	496	457	385
535	538	539	542	540	540	538	537	533	526	490	452	379
540	543	546	547	547	546	547	557	551	545	515	462	389
545	465	561	521	533	558	392	408	512	549	522	322	376
550	547	550	551	551	550	549	556	552	546	516	462	381

Time (s)	Tree 5 Ceiling	Tree 5 0.3 m	Tree 5 0.6 m	Tree 5 0.9 m	Tree 5 1.5 m	Tree 5 2.1 m	Tree 5 2.7 m	Tree 5 3 m	Tree 5 3.3 m	Tree 5 4 m	Tree 5 4.6 m	Tree 5 5.5 m
555	550	552	553	553	552	551	558	554	550	527	465	387
560	551	553	555	554	553	553	557	554	551	517	475	390
565	553	555	556	556	556	555	563	558	554	529	479	399
570	558	560	561	560	560	558	560	555	551	518	476	399
575	557	559	559	560	560	558	567	559	551	512	477	395
580	555	557	559	557	558	555	551	543	537	500	473	387
585	562	566	564	565	565	563	573	565	546	501	475	389
590	564	566	567	566	566	564	563	549	542	506	482	403
595	556	559	561	559	560	558	558	550	539	505	487	404
600	560	563	564	563	563	561	563	555	548	512	487	406
605	564	567	568	567	567	566	573	569	560	525	488	404
610	568	571	572	571	570	570	569	563	558	523	488	412
615	565	570	569	569	568	567	575	566	556	526	497	410
620	568	573	572	427	572	443	582	565	559	541	498	426
625	569	575	573	184	573	444	586	571	565	535	502	414
630	569	573	573	184	572	444	587	564	555	517	490	401
635	563	567	569	184	567	439	572	554	549	521	496	420
640	571	578	577	189	576	448	592	576	572	531	500	416
645	573	579	578	192	577	450	594	577	568	529	504	429
650	577	581	582	193	580	460	597	582	577	546	514	440
655	586	591	588	199	588	468	612	598	582	561	515	447
660	577	582	582	209	580	461	583	562	556	532	499	419
665	573	579	578	576	576	574	568	560	557	526	502	427
670	573	578	578	575	575	572	574	569	561	531	504	446
675	574	579	578	572	576	565	580	575	567	524	496	446
680	580	584	584	578	582	569	581	578	569	536	507	457
685	581	585	585	578	583	572	590	589	582	558	514	471
690	587	592	591	585	589	581	598	600	599	572	525	468
695	590	594	593	591	592	589	589	598	596	564	527	459
700	591	596	594	593	592	596	595	595	594	569	522	452
705	591	593	593	591	592	577	577	591	590	571	538	457
710	591	594	594	544	415	556	556	592	586	561	519	456
715	390	468	604	514	119	548	547	626	612	578	285	452
720	413	472	611	523	106	563	560	567	617	584	289	489
725	409	483	618	534	99	566	564	631	621	602	289	503
730	448	530	616	610	469	618	617	607	606	588	314	490
735	510	709	624	610	564	618	618	632	634	622	440	500
740	546	500	617	518	393	607	606	614	615	323	241	533
745	437	455	491	228	494	434	536	627	635	295	249	273
750	701	706	752	365	230	512	493	742	742	306	245	740
755	305	718	797	440	759	415	399	789	764	227	378	348
760	758	706	708	643	656	751	293	689	566	704	770	584
765	622	577	606	575	293	631	288	572	587	438	531	554
770	570	524	552	525	292	557	502	530	511	409	495	535

Temperature measurements (°C) and carbon monoxide volume fractions (%) at a location 36.6 m from front wall (9.1 m from the test area dividing wall) and 7.6 m from the east wall obtained during second test

Time (s)	0.9 m above floor		0.025 m above Floor	
	Temperature (°C)	CO (%)	Temperature (°C)	CO (%)
-60	21	-0.02	21	-0.12
-55	21	-0.02	21	-0.12
-50	21	-0.02	21	-0.12
-45	21	-0.01	21	-0.12
-40	21	-0.02	21	-0.12
-35	21	-0.02	21	-0.12
-30	21	-0.03	21	-0.12
-25	21	-0.02	21	-0.12
-20	21	-0.02	21	-0.12
-15	21	-0.02	21	-0.12
-10	21	-0.02	21	-0.12
-5	21	-0.02	21	-0.12
0	21	-0.02	21	-0.12
5	21	-0.02	21	-0.12
10	22	-0.02	21	-0.12
15	21	-0.01	21	-0.12
20	22	-0.02	22	-0.12
25	22	-0.03	22	-0.12
30	22	-0.02	22	-0.12
35	22	-0.02	22	-0.12
40	23	-0.02	22	-0.12
45	23	-0.02	22	-0.12
50	23	-0.01	22	-0.12
55	24	-0.01	23	-0.12
60	23	-0.02	23	-0.12
65	23	-0.02	23	-0.12
70	23	-0.02	23	-0.12
75	24	0.08	23	-0.12
80	24	0.01	23	-0.12
85	25	-0.10	23	-0.12
90	25	-0.08	24	-0.11
95	25	-0.03	24	-0.12
100	25	-0.02	24	-0.12
105	25	-0.02	25	-0.12
110	25	-0.02	26	-0.12
115	25	-0.02	25	-0.12
120	26	-0.02	25	-0.12
125	26	-0.01	24	-0.12
130	26	-0.02	24	-0.12
135	27	-0.02	25	-0.12
140	28	-0.02	26	-0.12
145	29	-0.02	26	-0.12
150	30	-0.01	29	-0.12
155	32	-0.02	30	-0.12
160	33	-0.03	31	-0.12
165	35	-0.02	31	-0.12
170	38	-0.02	33	-0.12
175	45	-0.02	38	-0.12
180	56	-0.02	44	-0.12
185	67	-0.03	57	-0.12
190	89	-0.02	63	-0.12
195	111	-0.01	67	-0.12
200	123	-0.02	69	-0.12
205	121	-0.01	74	-0.12
210	120	-0.02	71	-0.12
215	135	-0.02	77	-0.12
220	138	-0.01	82	-0.12
225	126	-0.02	98	-0.12

Time (s)	0.9 m above floor		0.025 m above Floor	
	Temperature (°C)	CO (%)	Temperature (°C)	CO (%)
230	105	-0.02	98	-0.12
235	107	-0.02	76	-0.12
240	110	-0.02	72	-0.12
245	106	-0.02	70	-0.12
250	107	-0.02	74	-0.12
255	107	-0.02	79	-0.12
260	104	-0.01	73	-0.12
265	102	0.00	71	-0.12
270	111	0.01	74	-0.12
275	113	0.02	72	-0.12
280	115	0.06	71	-0.12
285	117	0.08	72	-0.12
290	122	0.09	72	-0.12
295	117	0.10	73	-0.12
300	122	0.11	69	-0.11
305	125	0.12	66	-0.05
310	121	0.16	69	0.04
315	126	0.19	71	0.12
320	129	0.19	72	0.20
325	133	0.21	69	0.24
330	132	0.29	69	0.23
335	137	0.38	70	0.23
340	152	0.39	65	0.25
345	158	0.38	69	0.25
350	157	0.38	73	0.20
355	160	0.44	69	0.18
360	174	0.56	70	0.20
365	184	0.68	65	0.38
370	188	0.91	75	0.59
375	188	1.10	79	0.76
380	187	1.04	75	0.88
385	195	1.12	73	0.83
390	202	1.20	70	0.71
395	209	1.61	71	0.71
400	233	2.14	77	0.95
405	245	2.60	73	1.33
410	247	2.66	78	1.73
415	312	2.87	79	2.30
420	331	3.77	69	3.18
425	317	4.25	69	4.21
430	324	4.76	66	5.39
435	302	4.85	71	5.87
440	327	-0.01	71	0.00
445	308	0.00	75	0.00
450	310	0.00	74	0.00
455	323	0.00	80	0.00
460	361	0.00	79	0.00
465	375	0.00	85	0.00
470	357	0.00	88	0.00
475	345	0.00	91	0.00
480	348	0.00	87	0.00
485	342	0.00	93	0.00
490	354	-0.20	89	0.00
495	354	-0.32	93	0.00
500	355	-0.40	89	0.00
505	346	-0.45	94	0.00
510	322	-0.48	94	0.00
515	335	-0.50	87	0.00
520	346	-0.51	101	-0.01
525	352	-0.52	99	-0.01
530	325	-0.53	101	-0.01
535	338	-0.53	103	-0.01
540	335	-0.53	104	-0.01
545	321	-0.53	100	-0.01

Time (s)	0.9 m above floor		0.025 m above Floor	
	Temperature (°C)	CO (%)	Temperature (°C)	CO (%)
550	337	-0.53	101	-0.01
555	334	-0.54	100	-0.01
560	347	-0.54	99	-0.01
565	342	-0.54	99	-0.01
570	335	-0.54	101	-0.01
575	335	-0.54	100	-0.01
580	331	-0.54	103	-0.01
585	304	-0.54	103	-0.01
590	344	-0.54	103	-0.01
595	321	-0.54	102	-0.01
600	354	-0.54	105	-0.01
605	357	-0.54	104	-0.01
610	345	-0.54	110	-0.01
615	356	-0.54	116	-0.01
620	370	-0.54	113	-0.01
625	351	-0.54	122	-0.01
630	341	-0.54	113	-0.01
635	352	-0.54	110	-0.01
640	330	-0.54	106	-0.01
645	363	-0.54	116	-0.01
650	381	-0.54	112	-0.01
655	378	-0.54	111	-0.01
660	369	-0.54	117	-0.01
665	362	-0.54	117	-0.01
670	379	-0.54	116	-0.01
675	359	-0.54	117	-0.01
680	382	-0.54	116	-0.01
685	395	-0.54	117	-0.01
690	381	-0.54	119	-0.01
695	384	-0.54	121	-0.01
700	390	-0.54	123	-0.01
705	378	-0.54	122	-0.01
710	166	-0.54	120	-0.01
715	166	-0.54	122	-0.01
720	169	-0.54	133	-0.01
725	175	-0.54	121	-0.01
730	177	-0.54	120	-0.01
735	181	-0.54	125	-0.01
740	186	-0.54	125	-0.01
745	195	-0.54	125	-0.01
750	200	-0.54	131	-0.01
755	212	-0.54	138	-0.01
760	220	-0.54	139	-0.01
765	220	-0.54	128	-0.01
770	222	-0.54	134	-0.01

