

Calibration Experiments of a Laser Scanner

Building and Fire Research Laboratory
Gaithersburg, MD 20899



United States Department of Commerce
Technology Administration
National Institute of Standards and Technology

Calibration Experiments of a Laser Scanner

Geraldine S. Cheok
Stefan Leigh
Andrew Rukhin

September 2002
Building and Fire Research Laboratory
National Institute of Standards and Technology
Gaithersburg, MD 20899



U. S. Department of Commerce
Donald L. Evans, *Secretary*
Technology Administration
Phillip J. Bond, *Under Secretary*
Technology Administration
National Institute of Standards and Technology
Arden L. Bement, *Director*

ABSTRACT

The potential applications of laser scanners or LADARs (Laser Detection and Ranging) are numerous, and they cross several sectors of the industry – construction, large-scale manufacturing, remote sensing, national defense. A LADAR is an instrument which can rapidly capture 3-D data of a scene in the form of x , y , z points. The confidence in end products of the applications – 3D models, positioning, derived quantities – depends largely on the accuracy and precision of the laser scanner. For global uncertainty analysis via error propagation, specific instrumental uncertainties need to be determined.

This report chronicles exploratory experiments conducted at the National Institute of Standards and Technology to characterize a LADAR, focusing on accuracy and precision. The specific variables considered were distance, angle of incidence, and target color. Other characteristics of the LADAR such as the returned intensity and beam divergence were also examined.

Initial findings indicate no obvious global color effect on accuracy although range-specific biases were observed. Decreased measurement accuracy is observed for higher angles of incidence. Reflectivity contributes to measurement error with highly reflective targets exhibiting large errors in the shorter ranges and low reflective targets being less precise in the longer ranges.

These initial efforts are expected to contribute to the understanding of what is required to calibrate similar sensors in terms of significant parameters, test procedures, and calibration facility requirements.

TABLE OF CONTENTS

ABSTRACT	iii
CONTENTS	v
1.0 INTRODUCTION	1
2.0 EXPERIMENTAL PARAMETERS AND PROCEDURES	5
2.1 Data Set 1 – Effect of Color on Range Accuracy	6
2.2 Data Set 2 – Effect of Distance (0 m to 60 m) on Range Accuracy	7
2.3 Data Set 3 – Extension of Data Set 2 (60 m to 108 m)	8
2.4 Data Set 4 – Effect of Distance (5 m to 160 m) on Range Accuracy	8
2.5 Data Set 5 – Effect of Distance (10 m to 150 m) on Range Accuracy and Effect of Distance on Intensity Value	9
2.6 Data Set 6 – Effect of Angle Incidence on Accuracy	12
2.7 Data Set 7 – Spatial Correlation.....	15
2.8 Data Set 8 – Autocorrelation.....	16
3.0 ANALYSIS AND DISCUSSION OF RESULTS	17
3.1 Color	17
3.1.1 Data Set 1	17
3.1.2 Data Set 4	22
3.1.3 Data Set 5	27
3.1.4 Combined Data Sets	31
3.2 Intensity.....	32
3.3 Angle of Incidence	35
3.3.1 Data Set 6	35
3.3.2 Data Sets 5 and 6.....	46
3.4 Beam Divergence.....	47
3.5 Correlation	54
3.5.1 Temporal Autocorrelation – Data Set 8	55
3.5.2 Spatial Autocorrelation – Data Set 7.....	57
4.0 CONCLUSIONS AND RESEARCH NEEDS	60
4.1 Summary and Conclusions.....	60
4.2 Research Needs.....	61
REFERENCES	63
APPENDIX A	65
APPENDIX B	82

1.0 INTRODUCTION

LADAR (laser detection and ranging) technology has been available since the 1970s. Its full potential, however, was not fully realized until recently (1990s) because of inhibitive cost and poor reliability of the early devices. However, advances in micro-chip lasers, optics, MEMS (microelectromechanical systems) technology, and computers have led to increases in speed of data acquisition, range accuracy and reliability as well as reduction in size and costs. As the use of LADARs increases, the need is growing to characterize their performance and to develop confidence limits for the LADAR data and their end products. There has been little effort in this area thus far.

A LADAR is an instrument which can rapidly capture 3-D data of a scene in the form of x, y, z points (point clouds, Fig. 1.1) as contrasted to photography, which gives a 2-D projection. In general, LADARs return two pieces of information, range (=distance) and intensity (function of the strength of the return signal). Additionally, some LADARS can obtain other spectral data such as R(ed), G(reen), B(lue) values which can be used to aid in object identification.

This report chronicles exploratory calibration experiments conducted at the National Institute of Standards and Technology (NIST). These experiments, conducted over a period of three years, served three purposes: 1) to characterize the performance of a laser scanner with the focus on accuracy and precision calibrations of the LADAR, 2) as a learning process for the use of and familiarization with the LADAR and 3) to address needs as they arose such as the examination of intensity for bar code recognition. The experimental variables included distance, target color (reflectivity) and angle of incidence. Additionally, the effect target material and distance on intensity, and the laser beam divergence were examined.

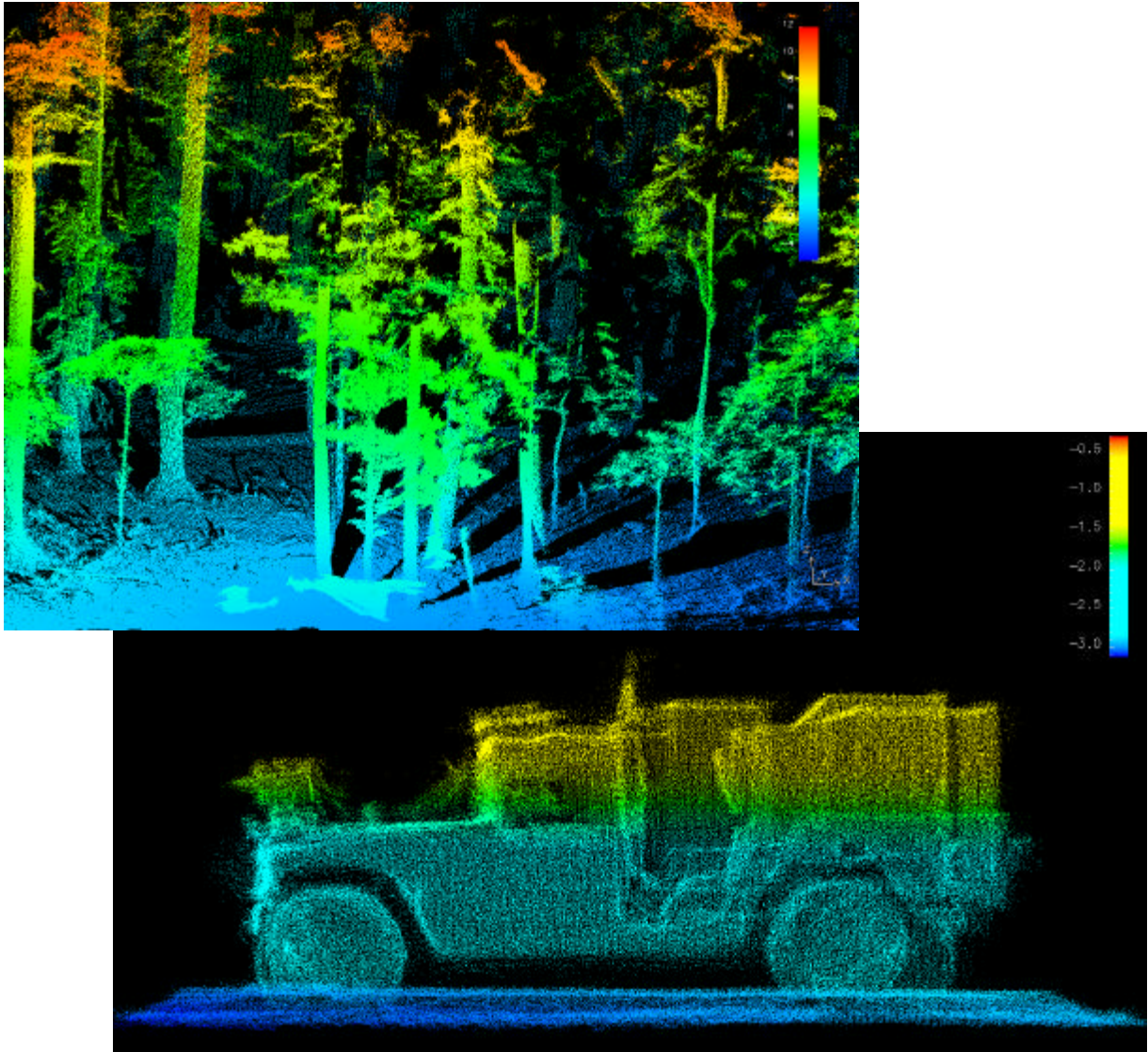
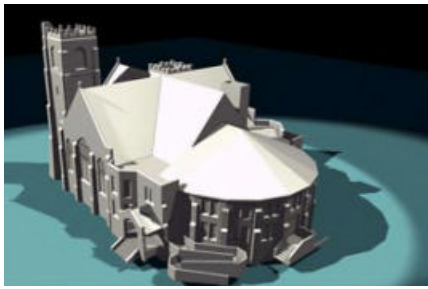
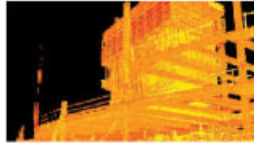

Figure 1.1. Point Clouds of a Wooded Area (top) and a Vehicle (bottom).

The potential applications of LADARs are tremendous, and they cross several sectors of the industry – construction, large-scale manufacturing, remote sensing, national defense (military). Some applications for LADAR data are shown in Fig. 1.2. These applications include creating 3-D models for as-builts, reverse engineering, surveying, urban planning, terrain mapping, and machine automation.



Courtesy of Quantapoint



Courtesy of Cyra

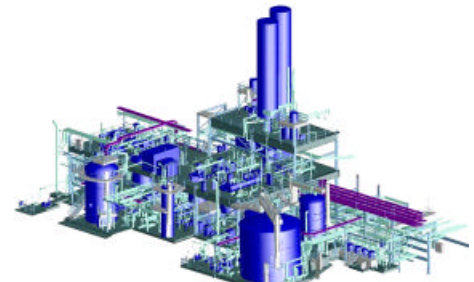

Courtesy of Airborne I

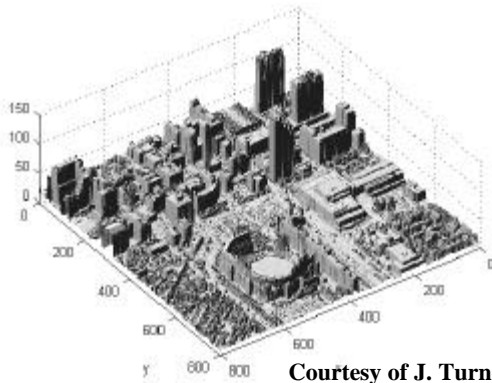

Courtesy of J. Turner, Rapid Terrain Visualization ACTD, Ft. Belvoir

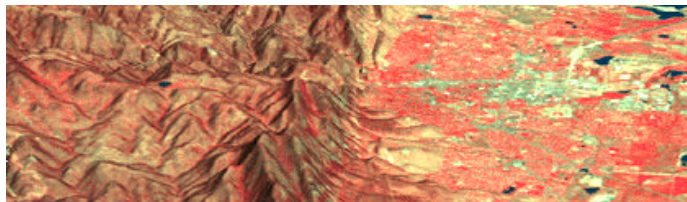

Courtesy of Computer Terrain Mapping Inc.



Courtesy of Cyra

Figure 1.2. Some Applications for LADAR Data –3D Models, Terrain Mapping, Surveying, Quality Control* .

The confidence in final products from the measurements - 3D models, positioning, derived quantities (e.g., volume), etc. – depends largely on the accuracy and precision of the laser scanner. Accuracy is defined by how close a measurement is to the true value, while precision is

* Certain trade names and company products are mentioned in the text or identified in an illustration in order to adequately specify the experimental procedure and equipment used. In no case does such an identification imply recommendation or endorsement by the National Institute of Standards and Technology, nor does it imply that the products are necessarily the best available for the purpose.

defined as the scatter or variation in repeated measurements. Generic instrumental uncertainties propagate through to end results.

A first, basic approach to the estimation of uncertainties associated with reconstruction of scene features is to incorporate propagation-of-error (“delta method”) based estimates of error [Taylor, 1997] to the surface generation (meshing) algorithms. Roughly, this requires first order estimates of error at any point in the mesh, i.e., standard error (or variance) of distance measurements, and if possible second order estimates of spatial covariances between points. Spatial covariance of measurements taken in close proximity leads to refinement (2nd order terms) in propagation-of-error generated standard errors. Negative covariances may be exploited to improve the error estimates. Positive covariances inflate error estimates. The standard temporal correlation measure is the serial autocorrelation. Presence of significant autocorrelation indicates that standard error propagation methods may produce results that are better than warranted. This is the underlying motivation for all the issues considered in this publication. We examine factors influencing the accuracy and precision of LADAR estimated distances (first order), and consider temporal autocorrelation and spatial covariance (second order) briefly as well in this report.

Besides instrument error, the computational techniques used to process the data contribute to the accuracy of estimating such derived quantities as volume and object position/dimensions. For example, model accuracy is affected by the number of points chosen to create the model (full or subset), and for a subset of points, selection of the points and number of points selected; if the point cloud consists of two or more scans obtained from different locations, how well were the different scans registered to a common reference frame; and how was noise filtered out.

This report deals primarily with the accuracy and precision (repeatability) of the hardware, i.e., the scanner, and not the software, and it describes experiments and statistical analyses conducted in order to determine the effect of color and angle of incidence on the accuracy and precision of the scanner’s range measurements. As a result of additional information gathered during the conduct of the range calibrations, the effect of distance on the signal intensity and laser divergence could also be studied. These initial efforts contribute to the understanding of what is required to calibrate similar sensors in terms of significant parameters, test procedures, and calibration facility requirements. Other similar efforts may be found in Marshall and Gilby [2001], Marshall et. al. [2001], Collier [1998], El-Hakim et. al. [1995], and Kweon et. al. [1991].

This report is organized as follows: An introduction is given in Chapter 1. Chapter 2 describes the different data sets and the conditions under which the data were collected. A discussion of the experimental results and an analysis of the results are given in Chapter 3. In Chapter 4, the findings based on the results of the experiments and research needs are presented.

2.0 EXPERIMENTAL PARAMETERS AND PROCEDURES

The laser scanner records range and intensity data. The maximum range of the tested laser scanner is 150 m, and the manufacturer’s specified accuracy varies from ± 2 cm (best case) to ± 5 cm (worst case). The range is based on the time-of-flight of the returned signal with the triggering of the detector based on the strength of return signal. The intensity data are integer values ranging from 0 (lowest) to 225 (highest) and are also a function of the strength of the return signal.

The signal strength is primarily dependent on the distance and reflectivity of the object. The reflectivity of the object is a function of the object’s color, texture (smooth, rough), specularity. Since the scanner would be used to scan scenes that contain objects of varying colors and textures, a pilot experiment to assess the influence of color and/or texture on the accuracy of the range measurements was conducted. As more understanding and hands-on experience with the scanner was gained, the effect of angle of incidence emerged as a significant effect on the range accuracy and precision. Thus, additional tests were conducted to determine the effect of angle of incidence on the range accuracy and precision. Also, as discussed in Section 2.5, data on the intensity value were collected as the need to determine the effect of distance on the intensity value arose. All experiments took place at the NIST, Gaithersburg campus at four indoor sites.

All experimental range data were collected in the form of (x, y) pairs where y = LADAR distance measurement and x = independent measurement of the distance, e.g., total station, interferometer or tape measure. This enables assessment of the accuracy of the LADAR as well as its precision.

A summary of the varying test conditions used to study the effect of distance, color, and angle of incidence on the range accuracy is given in Table 2.1 (an “X” in the column indicates that the parameter was studied). Color, specularity, and texture were varied between representative extremes and combined in fractional factorial fashion to examine the potential effects of each.

Table 2.1. Test Parameters.

Material	Distance	Angle of Incidence	Intensity
White, smooth, shiny	X	X	X
White, smooth, not shiny	X		
Yellow, smooth, not shiny	X		
Pink, smooth, not shiny	X		
Green, smooth, not shiny	X		
Dark Gray, rough, not shiny	X		
Black, smooth, shiny	X	X	X
Black, smooth, not shiny	X		
Silver (uncoated aluminum)	X	X	X
3M Long Distance Performance (LDP) – Reflective material	X		X

The most desirable distance calibration is an absolute distance calibration where the distance from the scanner to the target is accurately determined by independent means. However, for the first distance calibration, Data Set 1, the laser distances were compared with distances measured with an interferometer. The accuracy of the interferometer is several orders of magnitude better than that of the laser scanner. The interferometer is, however, a relative distance instrument. Therefore, the first calibration is a relative distance calibration. The subsequent data sets, Data Sets 2 to 8, are absolute distance calibrations.

No facility currently available at NIST allows for long distance (≥ 100 m) calibration. Therefore, the absolute distance calibrations were conducted at the following four locations: 1.) Metrology Building, Bldg. 220 (60 m maximum clear line of sight) 2.) Building Research, Bldg. 226 (≈ 110 m maximum clear line of sight) 3.) Corridor spanning several buildings (>150 m maximum clear line of sight) 4.) Tunnel, Bldg. 101 (> 150 m maximum clear line of sight). Except for the first location (Bldg. 220), environmental control was not possible at any of these sites. An ideal site would provide the following requirements: 1.) environmentally controlled (temperature, humidity, negative and positive barometric pressure control, uniform diffuse lighting) with multiple sensors throughout the lab to monitor the environmental conditions 2.) open space that is about 10 m (width) by 150 m to 200 m (length) 3.) controlled access into lab for eye safety and for ease of calibration (i.e., view of target not obscured by personnel walking between the target the scanner), 4) level concrete floor for installation of permanent benchmarks, and 5) diffuse black walls and floor.

2.1 Data Set 1 – Effect of Color on Range Accuracy

This set of measurements was conducted in an enclosed temperature controlled room located in the Metrology Building, Building 220 with fluorescent lighting where the temperature was held at approximately 20 °C. The maximum range achievable in this room is about 60 m. A heterodyne interferometer was used as the basis of comparison for the laser measurements. The accuracy of the interferometer is $(0.93 \mu\text{m}/\text{m}) / ^\circ\text{C}$ and $(0.36 \mu\text{m}/\text{m}) / \text{mm of Hg}$ (reference to 20 °C and 1013 hPa). The environmental conditions for the experiments in Data Set 1 are given in Table 2.2.

Table 2.2. Environmental Conditions for Data Set 1.

Test Date	Temperature (°C)		Relative Humidity (%)		Barometric Pressure (hPa)	
	Start	End	Start	End	Start	End
July 14, 1999	20.8	20.8	45.5	45.0	1005.7	1004.6
July 15, 1999	20.1	20.1	49.3	49.2	1007.3	1006.6
Aug. 2, 1999	20.0	20.4	49.4	49.5	999.3	999.3

The interferometer was set up at one end of the test bench and the laser scanner was set up slightly behind it. The target was mounted on top of a small trolley that travels the length of the test bench along a guided rail. Comparisons using the interferometer were relative distance comparisons. For example, the target was set at some arbitrary distance, usually 2 m to 3 m, in front of the interferometer and a zero reading was obtained to this target. Distances thereafter were relative to this initial starting point. In the case of the laser scanner, the measurement obtained to the target set at the start point represented the distance from the target to the scanner and was used as the zero offset for measurements taken thereafter.

The procedure involved both setting up the target and leveling the trolley. Readings were then obtained at the initial position from both the interferometer and the scanner. The target was moved 2 m, 4 m, 6 m, 8 m, 10 m, 15 m, 20 m, 30 m, 40 m, and 50 m beyond the start point. At each point, including the initial point, the distance was measured 25 times.

The target was made by mounting a piece of letter size [216 mm x 279 mm (8.5 in x 11 in)], colored paper to a piece of cardboard. The colors were white, green, yellow, pink, gray, and black. All the targets were smooth except for the gray target. The gray rough target was a sheet of 80 grit sand paper. To make the target shiny, the target was placed inside a plastic, protective cover. The data for these tests are given in Table A.1.

2.2 Data Set 2 – Effect of Distance (0 m to 60 m) on Range Accuracy

The same temperature-controlled location used for collecting Data Set 1 was also used for the first series of absolute distance measurements. Several collinear points (benchmarks), marked by ball bearings, are permanently set in the floor at specified spacings. The maximum distance between the two farthest points is 60.96 m.

The calibration procedure involved centering the scanner above one of the benchmarks and centering the target over another benchmark using a tribrach with an optical plummet. Twenty-five measurements were taken at each point. The scanner was set up at the “zero” mark and the target (white, not shiny) set up 30.48 m and 60.96 m from the scanner. The data from these tests are given in Table B.1. The environmental conditions were not recorded.

To determine the measurement error due to environmental factors, a short parametric study was conducted. The corrections for a distance of 100 m were computed for the following combinations of environmental conditions: temperature of 20 °C and 30 °C, barometric pressure of 1000 hPa and 1015 hPa, relative humidity of 20 % and 50 %, and CO₂ concentration of 0.027 % and 0.033 % (0.03 % ± 10 %). The maximum correction for 100 m was +1.5 mm (generally occurred for cases when the temperature was 30 °C). Assuming the environmental conditions were similar to those for Data Set 1 (20 °C, 50 % RH, 1000 hPa, 0.03 % CO₂), measurement error from environmental factors was +0.6 mm for 100 m. Thus, in this report, measurement errors from environmental factors are considered negligible compared to instrument error.

2.3 Data Set 3 – Extension of Data Set 2 (60 m to 108 m)

As the maximum calibration distance was 60.96 m (200 ft) for Data Set 2, two other locations were found that allowed for longer distance measurements. One location was the attic of the Building Research building, Bldg. 226. However, this location was neither environmentally controlled nor air-conditioned. The maximum distance at this location was about 108 m.

In the attic location, the distances between markers were measured with a tape measure. The distance ranged from 60 m to 108 m (measurements were taken to augment the data obtained in the environmentally controlled lab, Data Set 2; hence no measurements were taken at the shorter distances). Only one color target was used, white not shiny, and 25 measurements were taken at each distance. The target size was 216 mm x 279 mm (8.5 in x 11 in). The distance measurements were obtained on two different days, Jul. 28, 1999 and Aug. 2, 1999. The recorded temperature in the attic for the runs on Jul. 28, 1999 was 27.8 °C. No temperature was recorded for the tests on Aug. 2, 1999; however, based on data from the National Weather Service, the daily temperatures for Jul. 28, 1999 and Aug. 2, 1999 were comparable. The data from these tests are given in Table B.2.

The procedure used to center the scanner and target over a point on the floor is the same. It involves setting up a surveying tripod over the point, leveling a tribrach that is attached to the tripod, centering the tribrach over the point on the floor using the optical plummet, installing the scanner/target in a tribrach and locking it in, and re-leveling and re-centering the tribrach as needed.

2.4 Data Set 4 – Effect of Distance (5 m to 160 m) on Range Accuracy

Since the calibration distance for Data Set 3 was limited to 108 m, another location had to be found to determine the range accuracy at 150 m, the scanner's maximum range. The location selected was a hallway that spanned several buildings and offered a clear distance of at least 150 m. One side of the hallway that connected the buildings consisted of large glass windows, causing temperature variations along its length. However, all the buildings and hallways were air-conditioned and the temperature should be closer on average to the temperature of 20 °C than in the attic location (see Section 2.2 for discussion of measurement errors due to environmental factors).

The calibration distances in the hallway ranged from 5 m to 161 m. Markers were laid on the floor and the distances from the markers to a reference zero position were measured using a total station. The overall accuracy of the total station was ± 3 mm. The targets were white not shiny, green not shiny and black not shiny and the size of the targets was 216 mm x 279 mm (8.5 in x 11 in). To increase eye safety indoors, a filter was provided to reduce the energy of the laser. To determine the effect of the filter on the range accuracy, a series of measurements were made using the black not shiny and green not shiny targets. One set of measurements was obtained with the filter attached and another without the filter. In the previous calibrations, 25 measurements were obtained at each distance; however, it was decided that 10 measurements were sufficient to assess repeatability. Therefore, for this and subsequent data sets, 10

measurements were obtained at each distance. Data for these experiments are given in Table B.3.

2.5 Data Set 5 – Effect of Distance (10 m to 150 m) on Range Accuracy and Effect of Distance on Intensity Value

The calibrations described above (Data Sets 1 to 4) were aimed at getting a rough estimate of the general accuracy of the scanner and determining if the range accuracy and precision were dependent on material color. A further calibration was to characterize the scanner's range accuracy and to determine if there were any patterns in the intensity. Rather than using the location used for Data Set 4, an alternate location was found where the lighting and temperature would be more uniform throughout the length of hallway. This location was in a "tunnel" (long underground hallway) of Bldg. 101 of NIST. There are no windows along the tunnel. The calibration distances ranged from 10 m to 150 m. The various distances from the zero or reference point were obtained using a total station with an accuracy of ± 3 mm.

Based on a preliminary review of Data Sets 1 to 4, it was decided that only 3 colors would be used – white, black, and shiny silver (unpainted aluminum sheet). The target size was 406 mm (16 in) wide by 508 mm (20 in) long. The target size was chosen so that it would be larger than the size of the laser beam at 150 m.

NIST is currently examining the utility of using LADAR intensity data for "reading" bar codes or tags for the purpose of object identification. In order to "read" the bar code, its existence has to be first established. To do this, the bar code has to have a unique feature or characteristic so that it is easily identifiable. Therefore, the bar code would have to be made of a material that makes it easily distinguishable from any background material based on the returned intensity value. It was felt that a good candidate material would be one that had a return intensity that was much higher than any other material commonly found at a construction site and that was consistently high for distances of 0 m to 150 m, i.e., intensity did not drop off with distance. These requirements are essential as the returned intensity is dependent on several factors – reflectance of object, distance to object, reflectance of the surrounding objects, lighting (e.g., sunlight, shade), etc. This dependency means that the intensity of a black object at 10 m could be the same as the intensity of a shaded white object at 50 m and there would be no way to determine if the object was black or white based solely on the intensity value.

As a result, a fourth target made of 3M Long Distance Performance (LDP) material was made. The 3M LDP material is a reflective prismatic lens sheeting that is used for traffic signage. This material was chosen as it was readily available, durable, and would reflect light even if angled away from the light source. A photo of the LDP material and several magnified images are shown in Figs. 2.1 and 2.2 and it can be seen that the sheeting is made up of many small prisms.



Figure 2.1. Photograph of 3M LDP

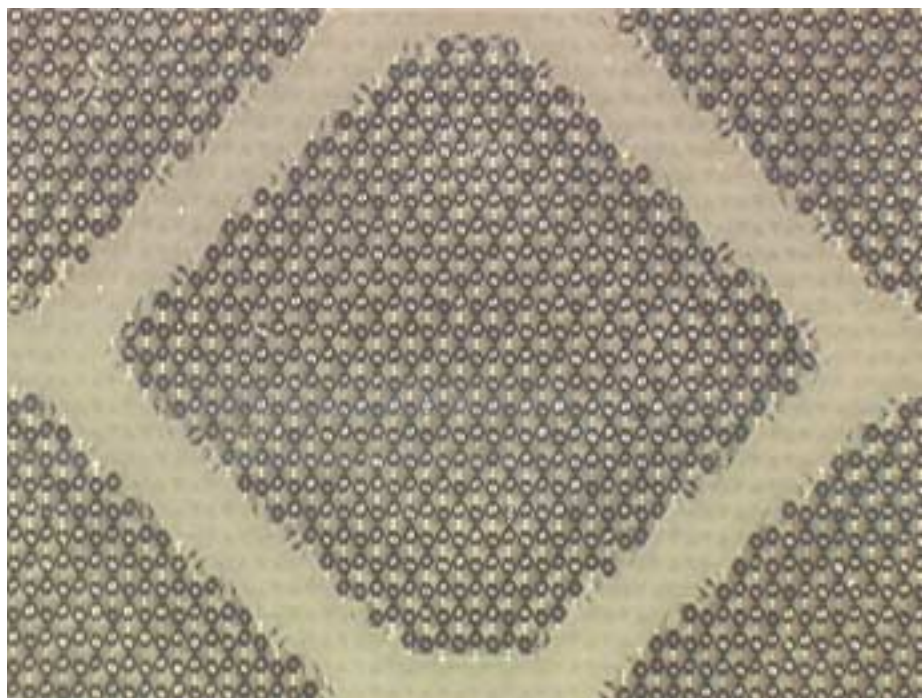

Figure 2.2a. Magnified Photo of LDP Material: Width represents 6 mm of surface.

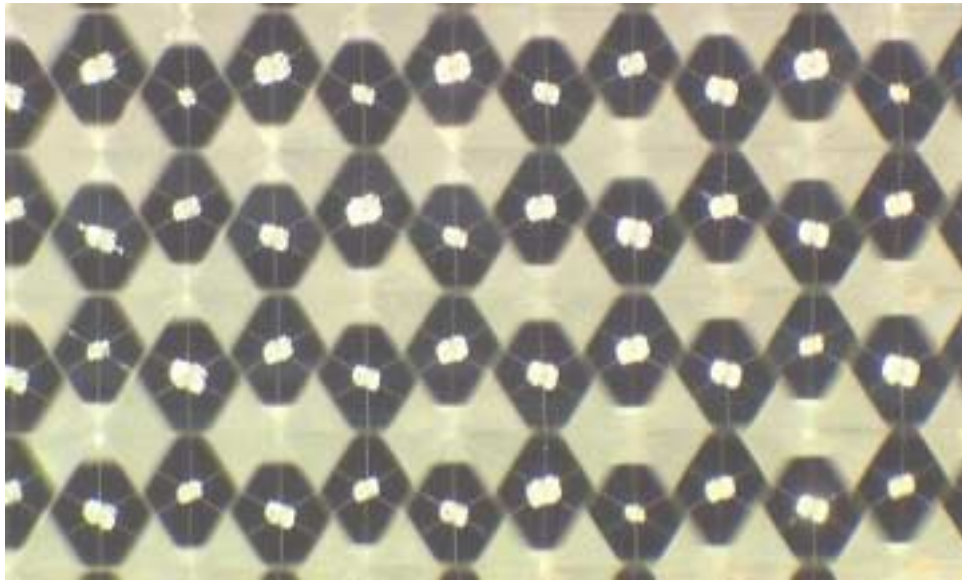
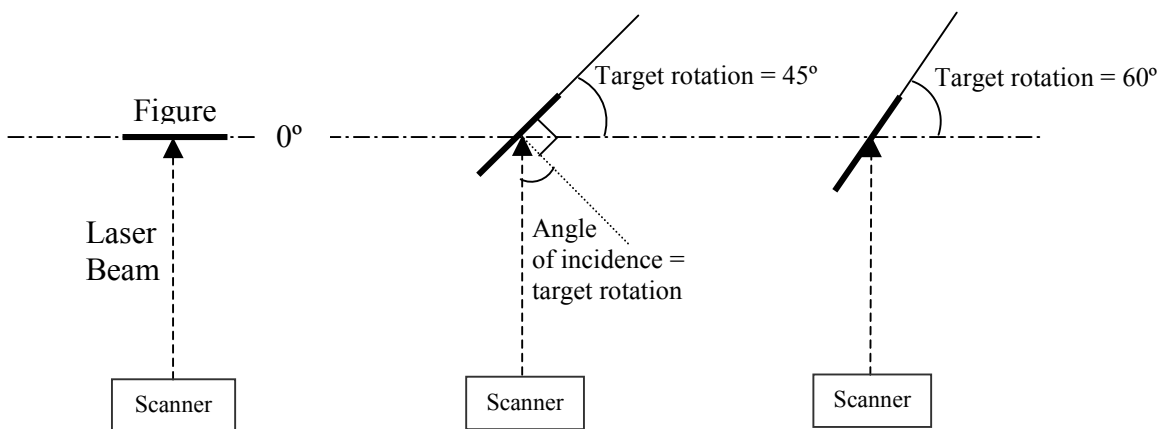

Figure 2.2b. Magnified Photo of LDP Material: Width represents 1.5 mm of surface.

In anticipation of the need to read bar codes angled away from the scanner, the LDP target was rotated to three positions – 0° , 45° , and 60° (Fig. 2.3).



Top View of Set-up

Figure 2.3. Rotation Orientation of LDP Target.

For Data Set 5, ten measurements (both range and intensity) were recorded at each distance. The data are given in Table B.4.

2.6 Data Set 6 – Effect of Angle Incidence on Accuracy

When conducting some simple scans of a box to test some post-processing software, the effect of split signals was noticed. Using the box as an example, split signals occurred when part of the signal hit the top of the box and the other part hit the floor beyond the box. The resulting instrument reported range is an interpolation between the two ranges. This creates “phantom points” (Fig. 2.4) – points that do not actually exist.

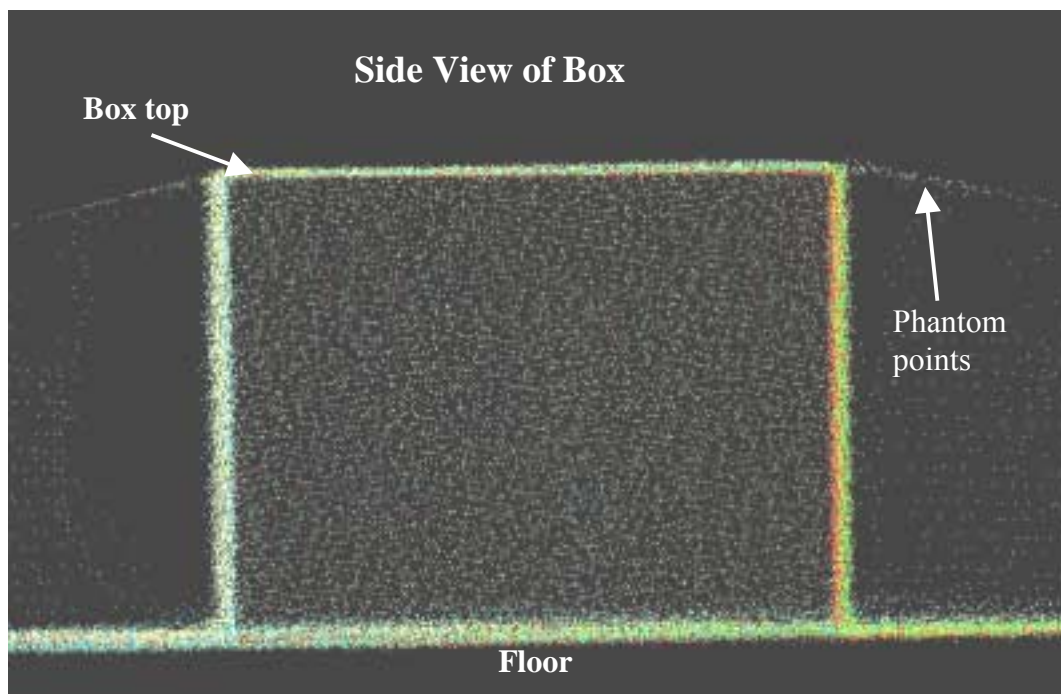

Figure 2.4. Point Cloud of Box Showing Phantom Points.

As stated by the manufacturer, the size of the laser beam as it exits the scanner is 42 mm (high) by 25 mm (wide). The beam has a divergence of 3 mrad, horizontal and vertical. This translates into a beam size of 342 mm (high) x 325 mm (wide) at 100 m. As a result of this large beam size and the splitting of the beam, it is probable that the range accuracy will be affected by the angle of incidence (see Fig. 2.3) – the greater the angle and the longer the distance, the more adverse the effect.

To determine the effect of the angle of incidence on range accuracy, the same three targets used for Data Set 5 were reused – white, black and shiny silver (uncoated aluminum). For these tests, the targets were rotated from 0° to 90° in increments of 10° (measurements were also obtained at 85°) with 10 measurements taken at each angle of incidence. The distance ranged from 10 m to

100 m in increments of 10 m. The location of the tests was the attic of Bldg. 226. The distances from the zero reference point were measured with a tape measure*.

The conduct of these tests was more difficult than those of the previous tests. Since the tests involved rotating the target, it was important that the center of the laser beam coincide with the center of the target. This presented some difficulty as the scanner utilized an infrared (IR) laser ($\lambda = 903 \text{ nm}$) and the laser was pulsed with a duration of 17 ns. As the main purpose of the scanner is to acquire data of a scene, the scanner could not be set up to automatically take the same point measurement repeatedly.

To find the center of the laser beam, an IR viewer was used to see the projection of the laser on the target. In order to see the laser projection through the IR viewer, the vicinity of the target had to be semi-dark for shorter distances (approximately 20 m or less) and be in total darkness for longer distances, because of the low laser power output. The procedure used to co-locate the beam center with the target center is as follows:

1. Set-up target over desired distance and attach a sheet of paper to the target.
2. Find the center of the target and mark it on the paper. Make a mark that is 79 mm (3.125 in) above the center mark (see Fig. 2.5).

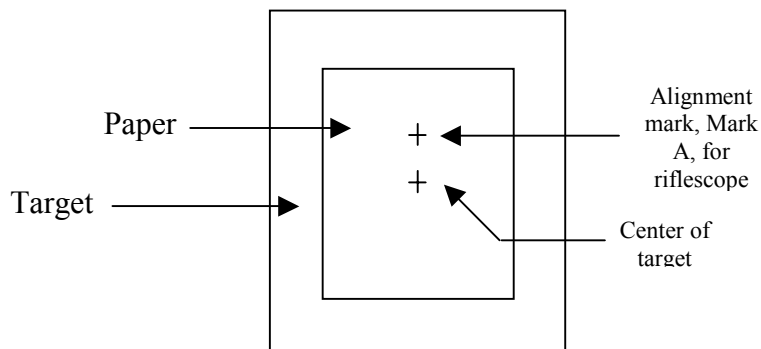

Figure 2.5. Alignment Markings on Target.

3. Align the crosshairs of the laser scanner riflescope with mark A (Fig. 2.5) on the target.
4. Turn off lights.
5. Have one person at the target with an IR viewer and another at the scanner control.
6. Have the person at the target outline the beam with a marker as the person at the control fires the laser in rapid succession.
7. Repeat Step 6 with a different person outlining the beam.
8. Turn lights on.
9. Find the center of the beam - visually.

* As the objective of this experiment was to determine the effect of angle of incidence and not to determine range accuracy, the reference distances were measured with a tape measure rather than with a total station.

10. If center of the beam does not coincide with center of the target, make the necessary rotations to the scanner to align the two centers and repeat Steps 4 to 10. If it does, continue with calibration.

Some notes about the above alignment process:

1. Step 6 – outlining the beam
 - a. This step is very subjective, which is the main reason why a second person repeated the procedure (Step 7).
 - b. The difficulty in outlining the beam was increased by the need for semi- to total darkness. It was very difficult to see where the pen was on the paper to assure that what was being outlined was indeed what was seen. For future tests, it may be easier if some type of fluorescent tape were attached near the tip of the marker so that it is visible in the dark.
 - c. Triggering of laser - for safety reasons, the laser only fires when the scanner is in motion, i.e., when it is scanning. For the calibration, the scanner was set up to acquire only one data point. The inability of the laser to fire continuously so that the projection of the beam could be seen more clearly increased the difficulty in outlining the beam.

Another issue that should be considered is the uncertainty of the pointing accuracy of the scanner. When the scanner obtains a point scan, it moves off the point to the next point. It therefore has to move back to the previous point to take another scan of the “same” point. This issue was not considered at this stage as 1) determining the pointing accuracy of the scanner would be an entire project in itself and 2) the contribution to the total error from this issue is insignificant compared to the operator error in outlining the beam.
 - d. The second person was not biased by the results of the first person as the markings on the paper were not visible, due to the total darkness, when the second person was outlining the beam.
2. In all cases except for one, visual inspection of the target showed that the centers of the beam and target were aligned after the first attempt and there was no need for further adjustments to reposition the scanner; the minimum movement of the scanner is limited by the minimum resolution of the stepper motor, i.e, the minimum angle between scan points. In the one instance where the centers did not coincide, only small adjustments were necessary to align the centers of the beam and the target. This indicates that the riflescope was aligned with the axis of the laser beam and that the alignment performed in Step 3 would yield a good alignment of the target with the scanner.

The data collection for this set was accomplished over a period of 3 nonconsecutive days. The environmental conditions when the data were collected are given in Table 2.3. On Feb. 26 and

27, 2002, the objective of the tests was to gather additional information on beam size as a function of distance and not to gather additional information on distance accuracy as a function of angle of incidence.

Table 2.3. Environmental Conditions for Data Set 6.

Date	Distance (m)	Temperature (°C)		Relative Humidity (%)		Barometric Pressure (hPa)	
		Start	End	Start	End	Start	End
Nov. 1, 2001	10	25.1	25.7	33.2	33.5	1007.0	1007.0
Nov. 5, 2001	20	23.8	23.8	26.5	26.5	1001.5	1002.0
Nov. 5, 2001	30	24.0	23.8	27.0	26.5	1001.5	1001.5
Nov. 28, 2001	40	22.5	23.6	38.5	40.0	1005.0	1005.5
Nov. 28, 2001	50	23.6	24.6	40.0	38.3	1005.5	1005.0
Nov. 28, 2001	60	25.2	25.4	34.2	35.0	1005.0	1004.0
Nov. 28, 2001	70	25.4	25.6	35.0	34.5	1004.0	1004.5
Nov. 28, 2001	80	25.6	25.6	34.5	38.5	1004.5	1005.0
Nov. 28, 2001	90	25.6	25.4	38.5	38.5	1005.0	1005.0
Nov. 28, 2001	100	25.4	25.2	38.5	37.2	1005.0	1005.5
Feb. 26, 2002	90, 5, 2	29.1	27.5	28	28	987	984
Feb. 27, 2002	100, 2	22.8	23.7	25	25	989	989

2.7 Data Set 7 –Spatial Correlation

This data set was designed to give initial estimates of spatial correlation for the simplest of LADAR scans: replicated points along closely spaced adjacent strips. The data acquisition was very simple. The procedure involved obtaining 3 vertical scan lines with each scan repeated 10 times (see Fig. 2.7). The variables in the experiment were the vertical and horizontal angle increments (0.045°, 0.090°, and 0.180°) – the vertical distance, v , between points. Twenty-five measurements per line were obtained for each line. The target was located 10 m from the scanner and was a sheet of plywood (4 ft x 8 ft) that was painted white. The data for this data set are given in Table B.6 in Appendix B.

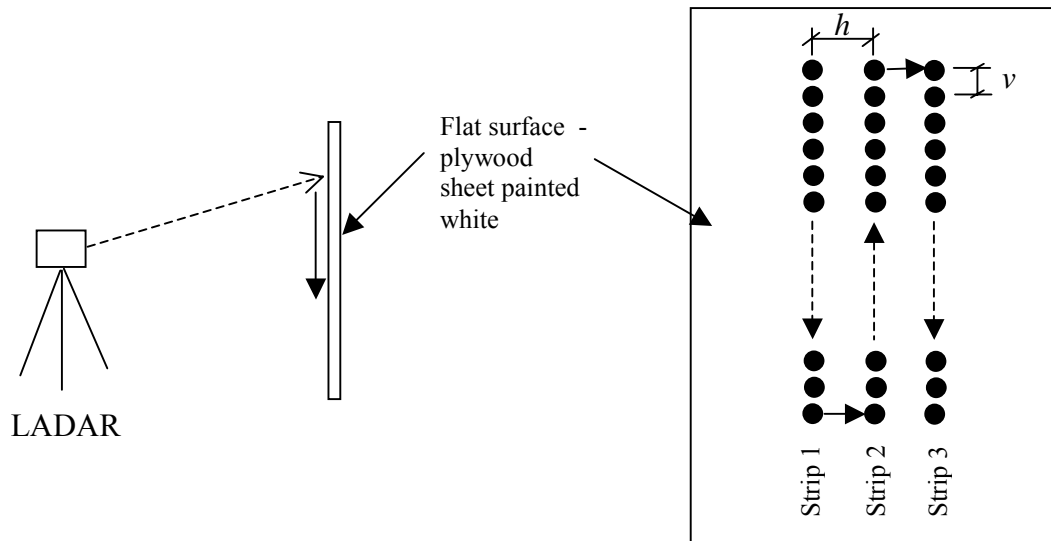

Figure 2.7. Schematic of Test Set-up.

2.8 Data Set 8 – Autocorrelation

The distance to the “same” point was measured 100 times to test the presence of autocorrelation. For this data set, the scanner was set up at about 20 m from a target. Once the scanner was set up, measurements were obtained by firing the laser and then manually recording the measurement – this procedure was repeated 100 times. The data are given in Table B.7, in Appendix B.

3.0 ANALYSIS AND DISCUSSION OF RESULTS

This chapter has been organized by the examination of specific effects rather than by a sequential discussion of each data set. The effect of color is presented in Section 3.1 and the data from Data Sets 1 to 6 are included. A discussion of the effect of target color/reflectivity and distance on intensity, Data Set 5, is given in Section 3.2. The effects of angle of incidence, Data Set 5 and 6, are presented in Section 3.3, and beam divergence, Data Set 6, is discussed in Section 3.4. Discussions of autocorrelation, Data Set 8, and covariance, Data Set 7, are given in Section 3.5.

3.1 Color

3.1.1 Data Set 1

Table 3.1 gives the slopes with associated standard uncertainties from ordinary linear least-squares fits of LADAR distance measurements versus interferometer distance measurements. In addition to the slope and its standard uncertainty, residual standard deviations from the fitted line are also reported in Table 3.1. The residual standard deviation is computed as the square root of the sum of squares of the deviations from the fitted line (residuals) divided by the degrees of freedom, $(N - 2)$, where N is the number of points and “2” represents the two parameter constraints (slope and intercept).

In Table 3.1, two sets of numbers are given for the slope, standard uncertainty and residual standard deviation: “Replicate” and “Averaged”. The values for the column labeled “Replicate” were obtained by fitting all the data points as though they were replicates. However, the points were not true replicates because the instrument was set up once and the points were taken in quick succession without the instrument being taken down and set up again after each distance measurement. Therefore, an average of the laser measurements at each distance was also fitted as a function of the interferometer distance, and the associated statistics for the regression fits are shown under the column labeled “Averaged” in Table 3.1.

Table 3.1. Data Set 1: Slopes and Standard Uncertainties From Regression Fits.

Color/texture	Slope		Standard Uncertainty of Slope (m)		Residual Std. Dev. (m)	
	Replicate	Averaged	Replicate	Averaged	Replicate	Averaged
White, smooth, not shiny	1.0070	1.0070	0.0005	0.0026	0.1305	0.1354
White, smooth, shiny	0.9989	0.9988	0.0001	0.0002	0.0254	0.0117
Black, smooth, not shiny	1.0034	1.0032	0.0002	0.0004	0.0334	0.0145
Black, smooth, shiny	1.0029	1.0029	0.0001	0.0004	0.0372	0.0227
Dark gray, rough, not shiny	1.0032	1.0032	0.0002	0.0005	0.0394	0.0177
Yellow, smooth, not shiny	0.9992	0.9992	0.0001	0.0003	0.0258	0.0173
Pink, smooth, not shiny	1.0001	1.00005	0.0002	0.0007	0.0412	0.0360
Green, smooth, not shiny	0.9993	0.9993	0.0001	0.0005	0.0294	0.0232
Green, smooth, not shiny	0.9995	0.9994	0.0001	0.0005	0.0301	0.0246

There are no gross differences between the slopes and standard uncertainties for replicate versus the average case. In both cases, there is no gross variation in slope and standard uncertainty across different color/texture combinations. The somewhat elevated standard uncertainty for the white, smooth, not shiny target may be because of it being the first experiment run. Variations observed (not reported here) in the intercept can be attributed to the relative nature of the distance measurements and are therefore of no interest. The replicate standard deviations consistently dominate the averaged residual standard deviations (with the exception of the aberrant white/smooth/not shiny), as we would expect. The average deviation from fit error for multiple lines should exceed that for a single (averaged) line. The replicate standard deviations exceed the manufacturer's specified accuracy of ± 2 cm for all cases, whereas the averaged are much closer to the manufacturer's specification for most cases.

Application of a formal statistical test [Sachs, 1982] for the equality of slopes of least-squares fitted lines of the replicated data, in this case very large N ($\approx 2\,357$) formally rejects the null hypothesis of equality of slopes. This is in agreement with the conclusion that would be drawn from comparing estimated slopes $\pm 2\sigma$ in Table 3.1, and is, at least in part, a consequence of the large sample sizes (≈ 275) associated with each of the individual line fits. Here, however, the formal test is of little direct utility. We find the more broadly applicable conclusions of the graphical analyses of range- and color dependent precisions and biases to be much more informative.

A plot of the accuracy, or bias, as a function of color and surface roughness for Data Set 1 is shown in Fig. 3.1. In Fig. 3.1, the terms "tall post" and "short post" refer to a post that was located slightly behind the target. In the case of the "tall post", the post extended above the target, while for the "short post" the post did not extend above the target. The calibration with the "short post" was undertaken to determine if the presence of the "tall post" contributed to the measurement errors. When no "tall" or "short" post is indicated, a "short" post was used.

The red dashed lines* in Fig. 3.1 indicate the stated instrument accuracy of ± 2 cm. From Fig. 3.1, several observations can be made:

1. Pink, not shiny stands out as being biased consistently (i.e., independent of distance) low with respect to the nominally "true" reading.
2. Dark gray and black targets are biased consistently high with the accuracy decreasing with increasing distance from the target. The precision of the measurements for these targets is also seen to decrease with increasing distance.
3. Green and yellow lie closer to the "truth".
4. There is a visible stratification of target types indicating an unambiguous color/roughness effect for accuracy.

* General notes: 1) Throughout this report, error is used to denote: $\text{Error} = \text{Measurement} - \text{"truth"}$. 2) Solid/dashed red lines in figures indicate stated instrument accuracy of ± 2 cm.

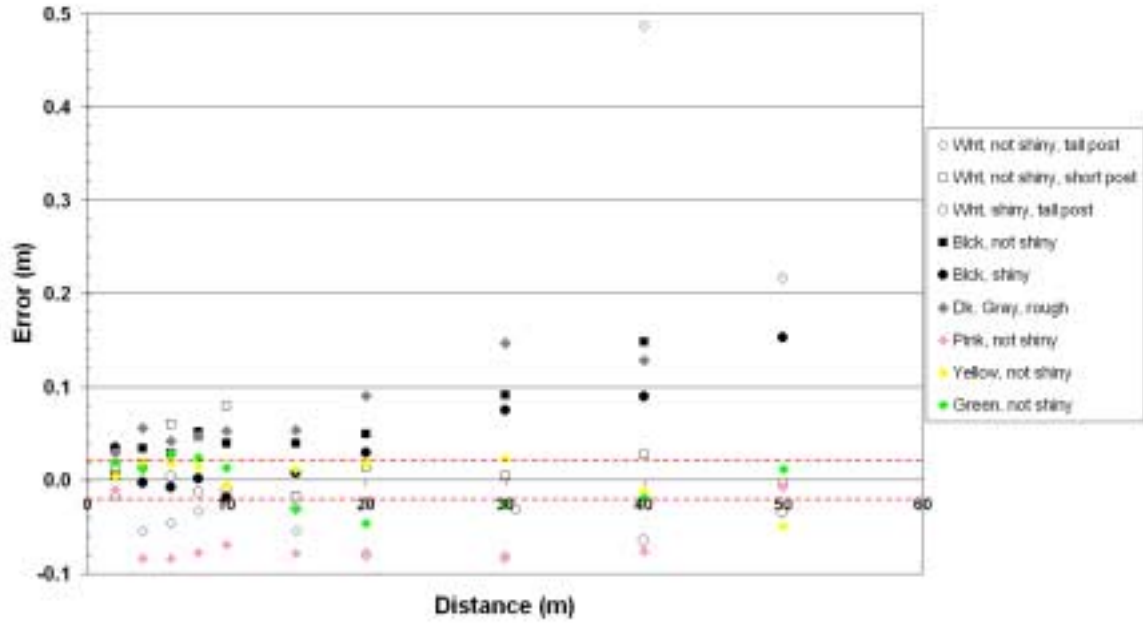

Figure 3.1 Data Set 1: Error vs. Distance
 (Error = Mean laser distance – Interferometer distance).

Figure 3.2 shows the scatter of the replicated laser measurements from Data Set 1 as a function of color/roughness and distance from the target. Here, standard deviation denotes the ordinary sample standard deviation (“s”) computed over the replicated points at each fixed nominal distance.

Again, some patterns are readily detected in the figure. White targets are noisier in the 0 m to 20 m range, and black targets exhibit the largest variation in the 30 m to 50 m range.

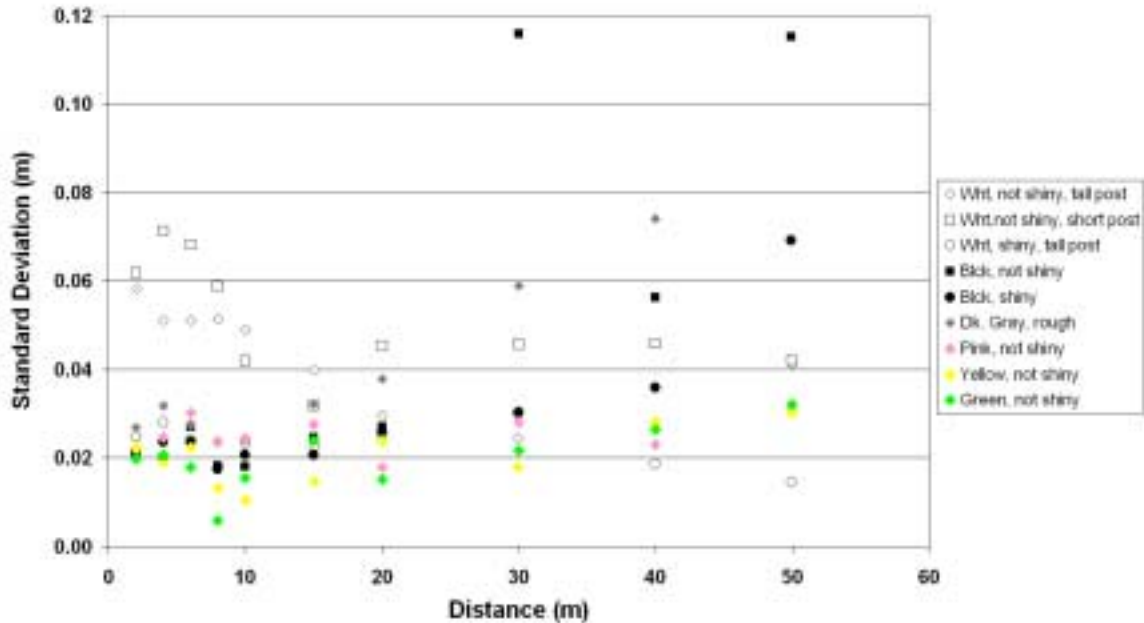
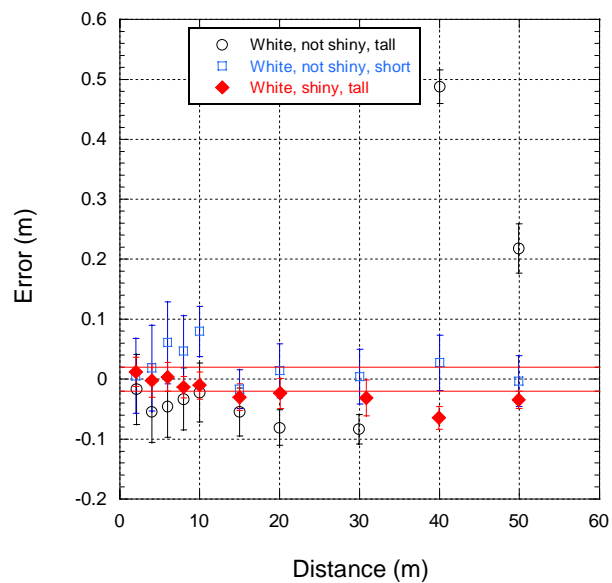

Figure 3.2. Data Set 1: Standard Deviation of Laser Measurements.

Figures 3.3a to 3.3f give a different representation of the data shown in Figs. 3.1 and 3.2. Accuracy and standard deviation (error bars in the figure) are plotted on the same plot for each color, separately. The observations made for the pink, yellow and green targets are also seen in Figs. 3.3d, e, and f. Some observations that are not so obvious in Figs. 3.1 and 3.2 can be appreciated in Figs. 3.3a, b, and c. In Fig. 3.3a (white target), the stratification in accuracy across the three targets represented is clear, offset only by the obvious white, not shiny, tall post highliers at 40 m and 50 m. The standard deviations for the material with the higher reflectance (shiny) are smaller than for the material with less reflectance (not shiny). Figures 3.3b and 3.3c (black and dark gray targets, respectively) show a clear decrease in both accuracy and repeatability as a function of increasing distance. For the black target, the one with the higher reflectance (shiny) shows a slightly lower error and greater repeatability than the target with lower reflectance.

The errors for the white, black, green, and yellow targets are seen to generally conform to the ± 2 cm specification, although the errors for the black target begin to deviate beyond 20 m. The pink and dark gray targets, on the other hand, exceed the specification almost immediately, and throughout the entire measured range.



a. White

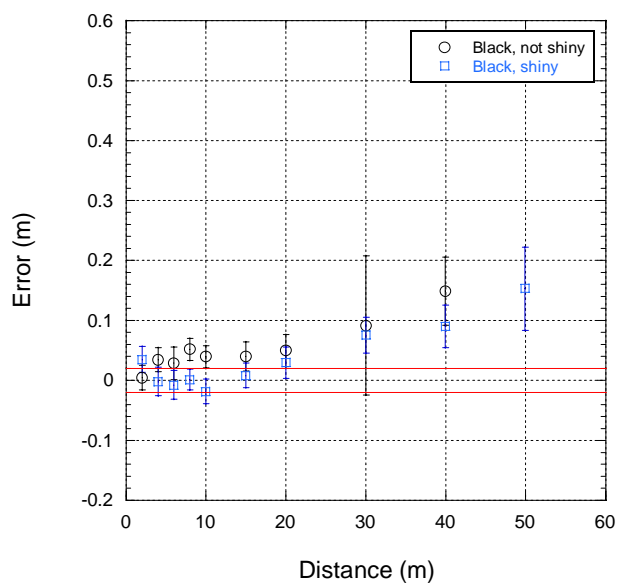

b. Black

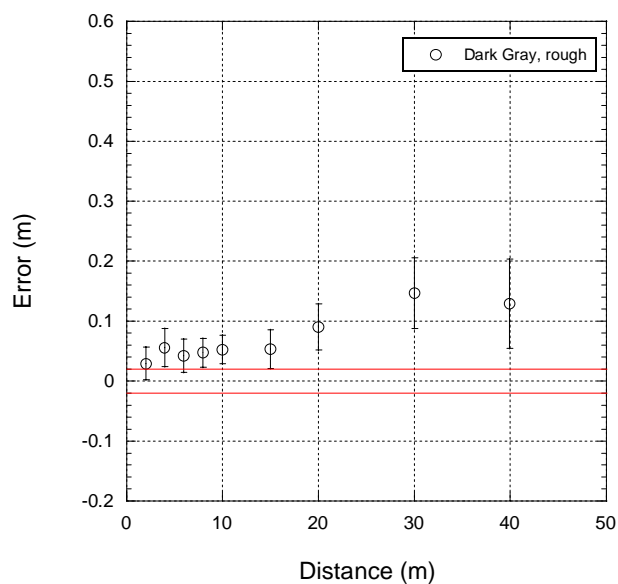

c. Dark gray

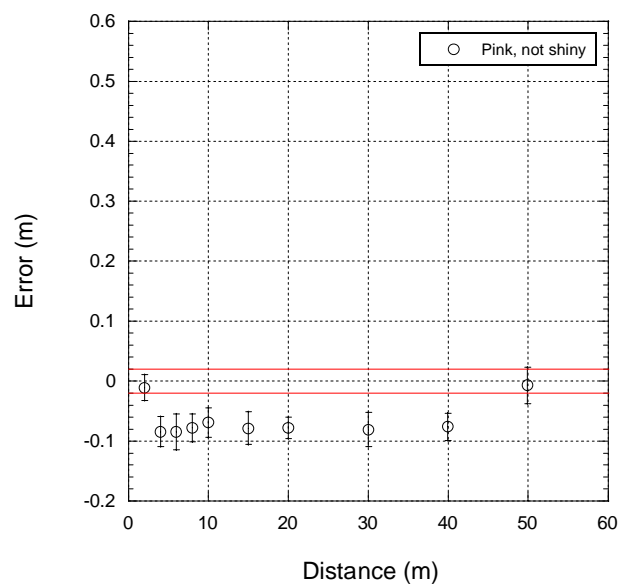

d. Pink

Figure 3.3. Data Set 1: Error Plots (Error bars = 1σ).

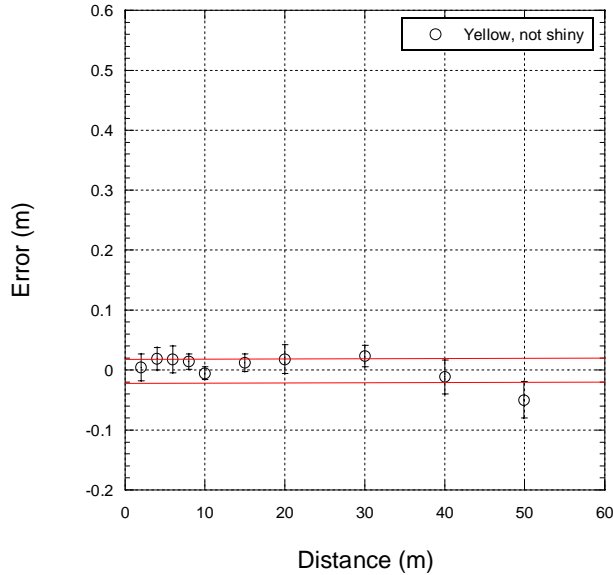

e. Yellow

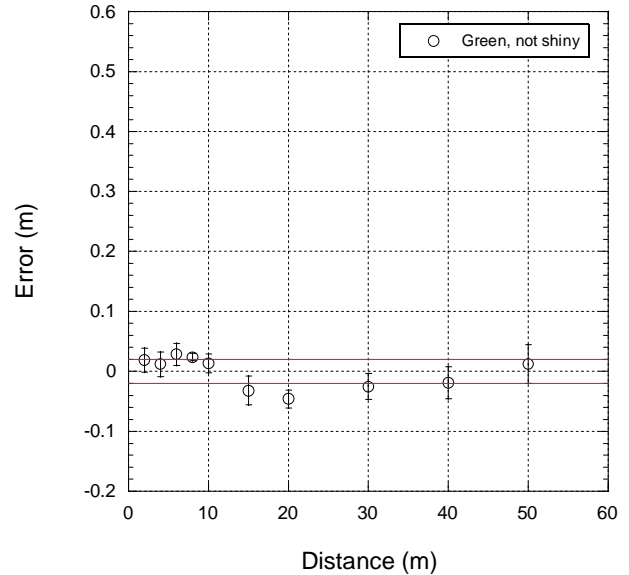

f. Green

Continue Figure 3.3. Data Set 1: Error Plots (Error bars = 1σ).

Summary for Data Set 1: Global goodness-of-fit or precision statistics do NOT exhibit any gross color/texture-specific pattern, while localized precision estimates, in some cases, do exhibit clear patterns. Most prominent are color specific inaccuracies in distance measurement, with the black target being biased high (beyond the specifications of the instrument), white and pink targets biased low, and colors in between the two extremes giving the most accurate readings.

3.1.2 Data Set 4

Table 3.2 shows the coefficients and statistics for the linear regression fits for Data Set 4 – the first data set where distances ranged from 5 m to 150 m. The notation “with Filter” or “Filter” refers to the case when a filter was attached to the front of the LADAR and the term “without Filter” or “No filter” refers to the case when the filter was removed. The filter was supplied by the manufacturer to reduce the output power of the LADAR for additional eye safety in indoor environments. It is expected that the data acquired with the filter attached would exhibit larger error and variability.

As seen in Table 3.2, comparison of the slopes for the black and green targets show little difference in the slopes and intercepts for the case of “with” and “without” filter. The F-test does not reject the null hypothesis of equality of slopes. However, for the black target, the residual standard deviation (RESSD) is reduced by (50 to 60) % when the filter was removed, i.e., the data were more precise without the filter. The results for the green target are inconclusive regarding precision and the presence of the filter.

Table 3.2 Data Set 4: Slopes and Standard Uncertainties From Regression Fits.

Target	Slope		Intercept (m)		Standard Uncertainty of Slope (m)		RESSD (m)	
	Replicate	Averaged	Replicate	Averaged	Replicate	Averaged	Replicate	Averaged
With Filter								
Black, not shiny	1.0010	1.0010	-0.0304	-0.0304	0.00013	0.00029	0.07382	0.05298
Green, not shiny	1.0001	1.0002	0.0252	0.0211	0.00014	0.00014	0.08347	0.02586
Without Filter								
Black, not shiny	1.0000	1.0002	0.0266	0.0208	0.00008	0.00025	0.04568	0.03526
Green not shiny	1.0000	1.0000	0.0153	0.0153	0.00009	0.00022	0.05090	0.03088
White, not shiny	1.0001	1.0001	0.0286	0.0282	0.00005	0.00010	0.02918	0.01763

Figures 3.4a and 3.4b show the error as a function of distance to the target for Data Set 4. Figure 3.4a shows the errors when no filter was attached to the LADAR. Fig. 3.4b shows the errors when the filter was attached to the LADAR.

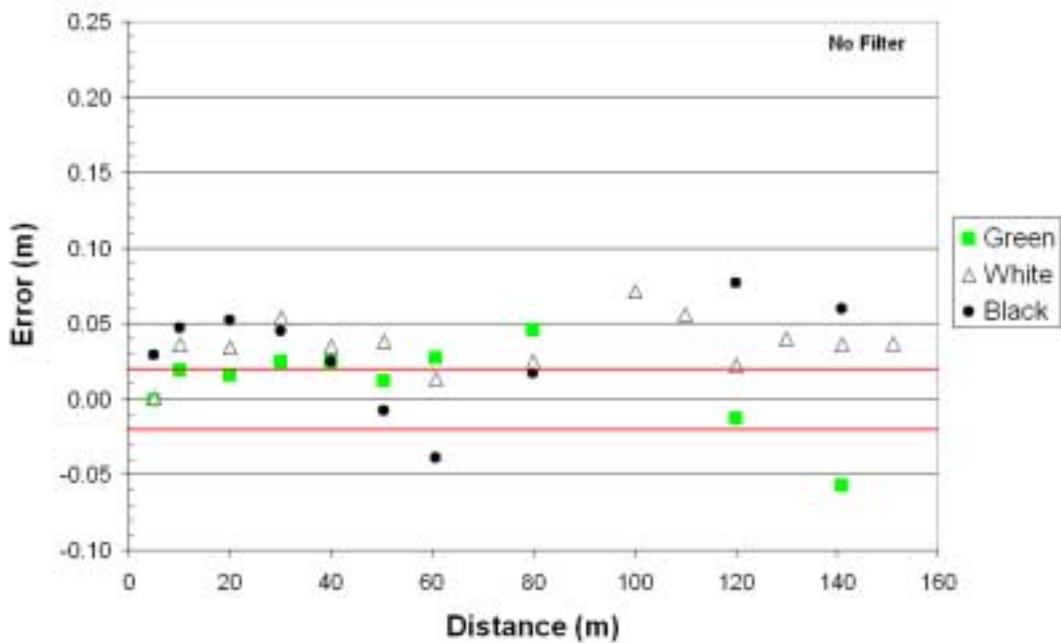

Figure 3.4a. Data Set 4: Error vs. Distance.
No Filter on LADAR

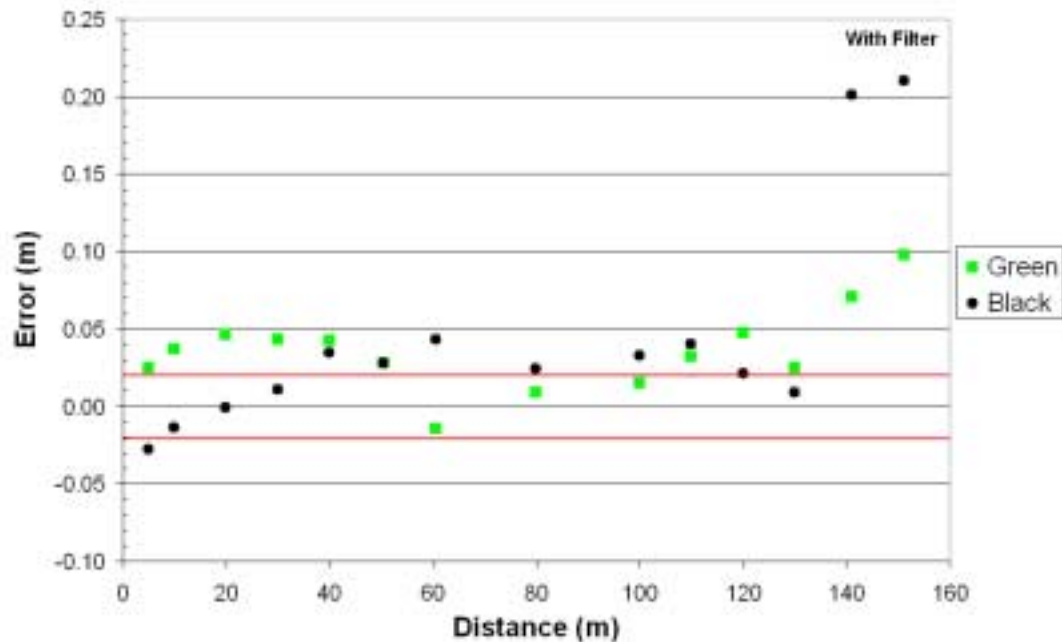

Figure 3.4b. Data Set 4: Error vs. Distance.
Filter on LADAR

In the “No Filter” figure (Fig. 3.4a), there is a subtle but unmistakable stratification between green and white targets, with white errors dominating across most of the range, specifically in the 0 m to 50 m and in the 100 m to 160 m regions. The errors attributed to the black target, in contrast, meander and intermix throughout the plot.

In the “With Filter” figure (Fig. 3.4b), there is no apparent color effect, although the error increases noticeably for both colors in the 140 m to 160 m range. It appears that the combination of reduced power due to the presence of the filter and dispersion of the signal strength with distance, and a less reflective (i.e., more absorbing) target has a significant adverse affect on the accuracy at the upper range of the scanner. Since Figs. 3.4a and b have the same vertical scale, they can be compared directly. Except for the high lying points at 140 m and 160 m, there is no readily apparent difference in accuracy between the filtered and unfiltered situations, contrary to expectations.

The standard deviations of the errors for Data Set 4 are given in Figs. 3.5a and 3.5b. The figures make clear that the measurements obtained with the filter are noisier than those obtained without the filter for distances of 120 m to 150 m. Also, a green versus black effect is clearly visible in the filtered case, variabilities (standard deviations) for the black target dominating those of the green for almost all the distances.

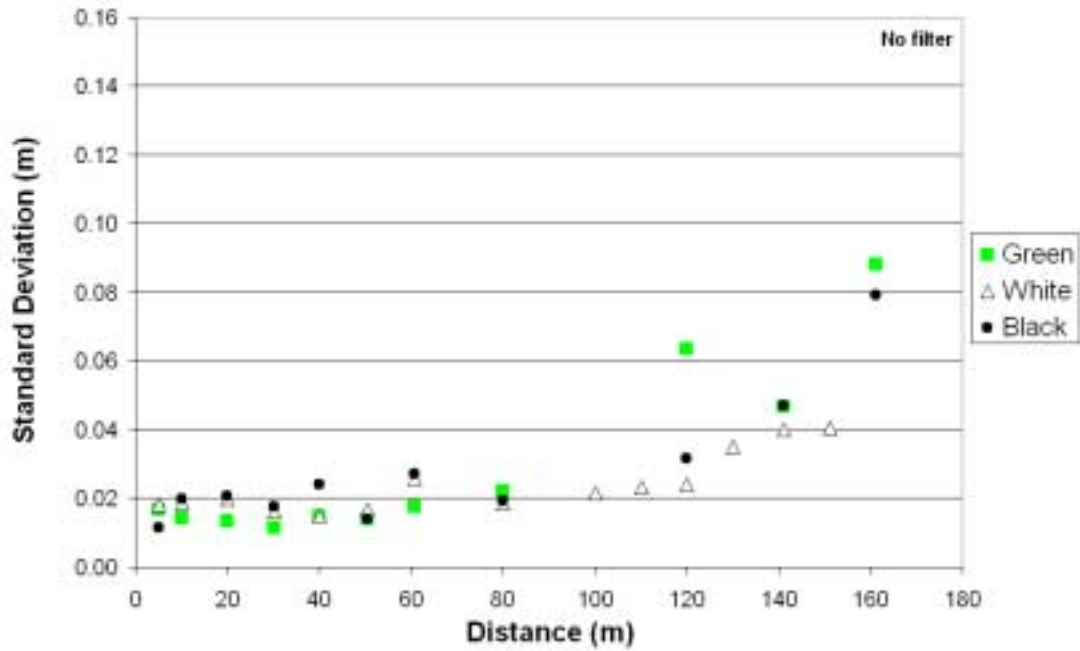

Figure 3.5a. Data Set 4: Standard Deviation of Errors.
No Filter on LADAR

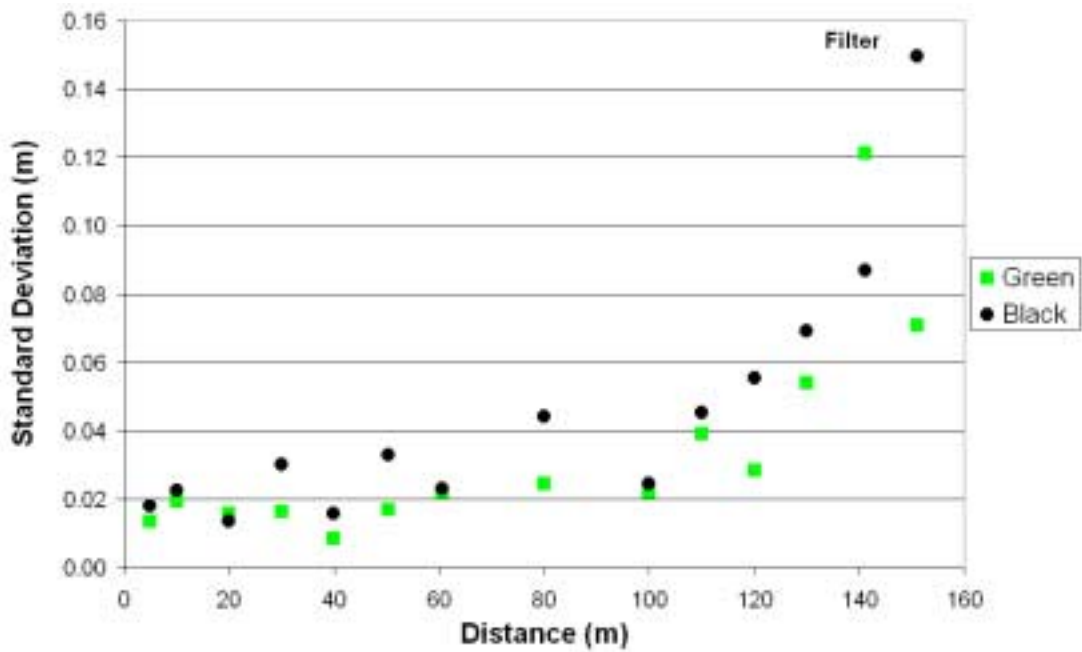
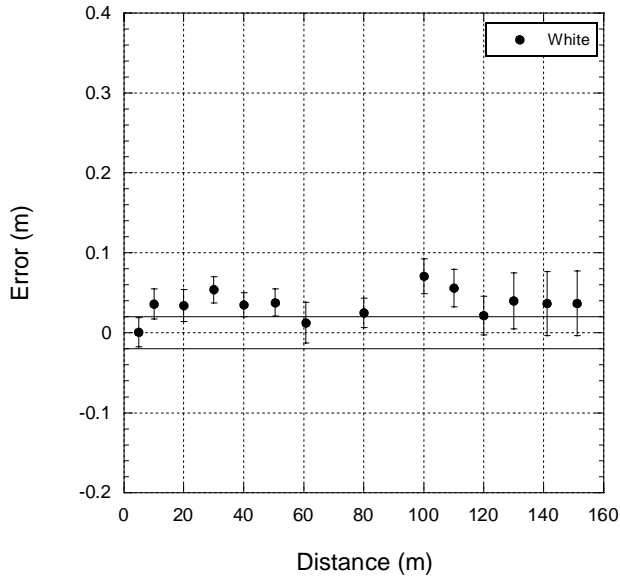
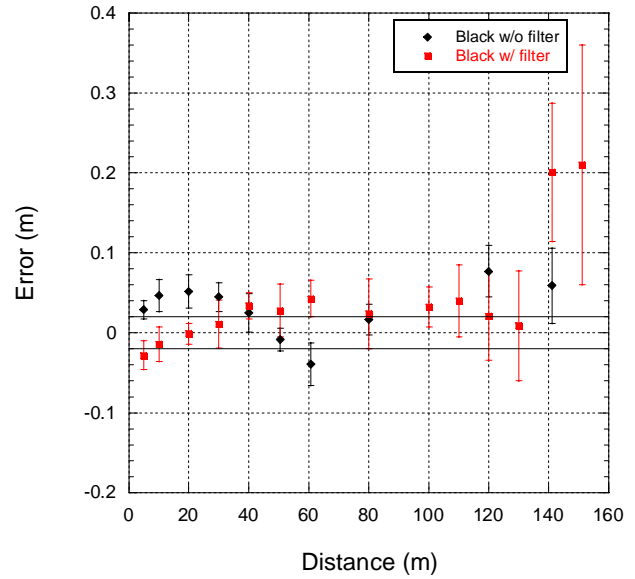

Figure 3.5b. Data Set 4: Standard Deviation of Errors.
Filter on LADAR.

Figures 3.6a to 3.6c break out the data from Figs. 3.4 and 3.5, a color at a time. Figures 3.6 reinforce the conclusions from Figs. 3.5, except that in addition, these figures make clear that (1) in all cases, variability increases with increased distance, and the consequent tendency for points to fall outside the specification ± 2 cm and (2) this heteroscedastic effect – in the case of length metrology – is especially pronounced for the filtered black and green cases.



a. White



b. Black

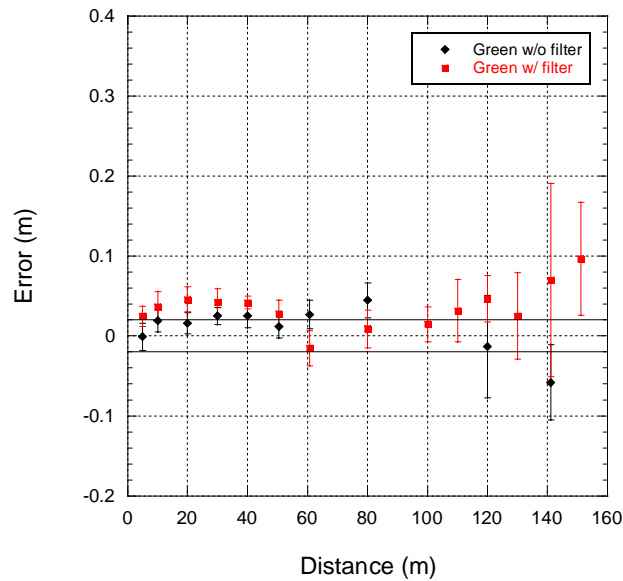

c. Green

Figure 3.6. Data Set 4: Error Plots (Error bars = 1σ)

Summary for Data Set 4: No marked filter or color effect is observed in the global line statistics. But subtle effects are observed with respect to localized precision and statistics, and significant effects with respect to accuracy. The presence of the filter significantly increases the error and noise for the black target (least reflective) at the upper range of the scanner.

3.1.3 Data Set 5

The locations at which the data for Data Sets 1 to 3 were collected did not allow for the calibration of the maximum range of the LADAR. The locations at which the data for Data Sets 4 and 5 were collected did allow for calibration of the maximum range of the LADAR. However, the location for Data Set 5 was felt to be more environmentally controlled than the location of Data Set 4 (see Section 2.4). Therefore, for these reasons in addition to the fact that more experience was gained by the time the data for Data Set 5 was collected, the data in Data Set 5 is considered to be more reliable for the evaluation of range accuracy and precision as a function of color and distance.

The coefficients for the regression fits for Data Set 5 are shown in Table 3.3. As with the previous data sets, there are no gross differences among the slopes and standard uncertainties of the slope except for the LDP, 60° target which has a standard uncertainty that is significantly higher than the rest, although, the formal F-test does reject the null hypothesis of the equality of slopes. The residual standard deviations for the black, white, and silver shiny targets are within about 10 % of each other and are slightly over the specified accuracy of ± 2 cm. The residual standard deviation for the LDP, 0° target is about 25 % greater than the average of the black, white, and silver, shiny targets. As expected, the residual standard deviation increased for increased angle of incidence – significantly greater than the ± 2 cm specified limits. Further comparisons of the LDP targets will be made in Section 3.3 (angle of incidence). Discussions in this section will generally include only the first four targets listed in Table 3.3 since they are comparable, i.e., the angle of incidences for these four targets are 0°.

Table 3.3. Data Set 5: Slopes and Standard Uncertainties from Regression Fits.

Target	Slope		Intercept		Standard Uncertainty of Slope (m)		RESSD (m)	
	Replicate	Averaged	Replicate	Averaged	Replicate	Averaged	Replicate	Averaged
Black	1.0001	1.0001	-0.0104	-0.0110	0.00007	0.00016	0.03875	0.02734
White	0.9995	0.9995	0.0210	0.0200	0.00007	0.00018	0.03501	0.03040
Silver, Shiny	1.0001	1.0001	-0.0254	-0.0256	0.00004	0.00005	0.02159	0.00878
LDP, 0°	0.9987	0.9987	0.1128	0.1132	0.00007	0.00021	0.03862	0.03563
LDP, 45°	0.9997	0.9996	-0.0200	-0.0193	0.00009	0.00027	0.04646	0.04464
LDP, 60°	1.0001	1.0000	0.0010	0.0029	0.00013	0.00041	0.06778	0.06844

The errors and standard deviations of the errors for Data Set 5 are shown in Figs. 3.7 and 3.8, respectively. In Fig. 3.7, the high reflectance of the LDP target induces significant error in the distance measurement for distances of 20 m or less. Overall, the LDP trace appears to linearly increase through the entire range. The large errors for the LDP target in the shorter distances (0 m to 50 m) are likely a result of the detector being saturated by the strong return signal of the

highly reflective material. Furthermore, these errors are biased low, that is, the target appears closer than in actuality. These observations were also noted by Collier [1998]. Reflectance is seen in this case to contribute directly to inaccuracy in the distance measurements.

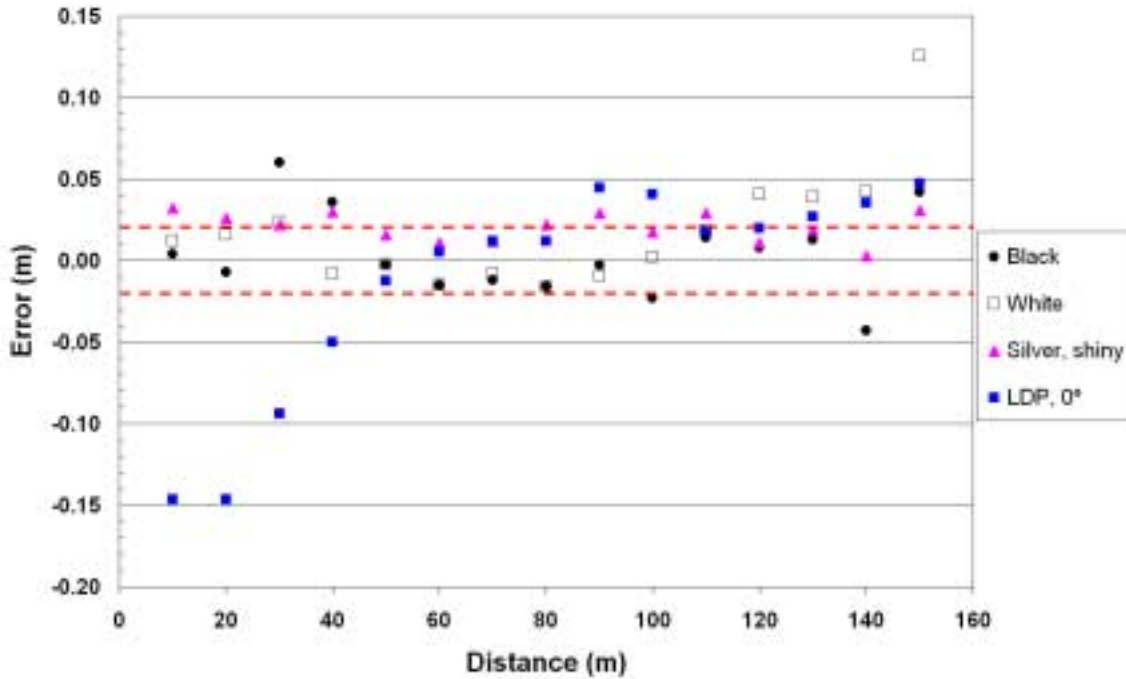

Figure 3.7. Data Set 5: Error vs. Distance.
 (Error = Mean laser distance – total station distance).

There are no obvious patterns for repeatability, or standard deviations of the replicated measurements, for most of the targets in Fig. 3.8: the values for white, silver shiny and LDP targets do not stand out in terms of increased or decreased or stratified noisiness. Black, however, does pull apart from the other three in the 80 m to 150 m range: the black measurements for this range are distinctly noisier than those for the other three targets.

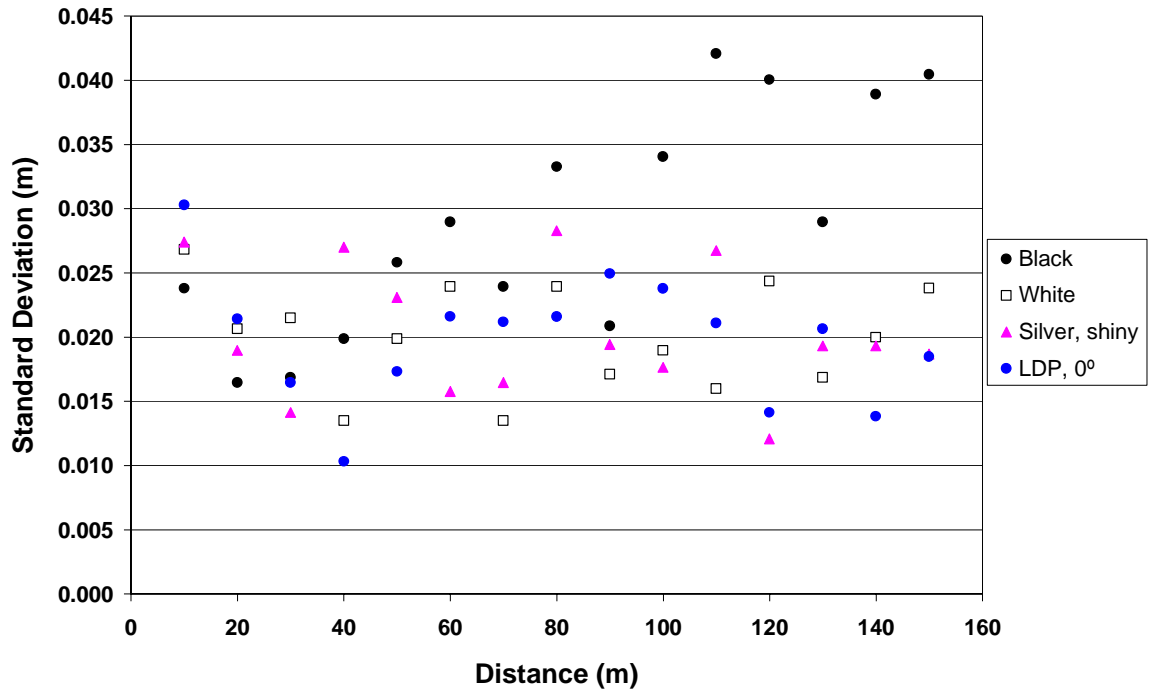
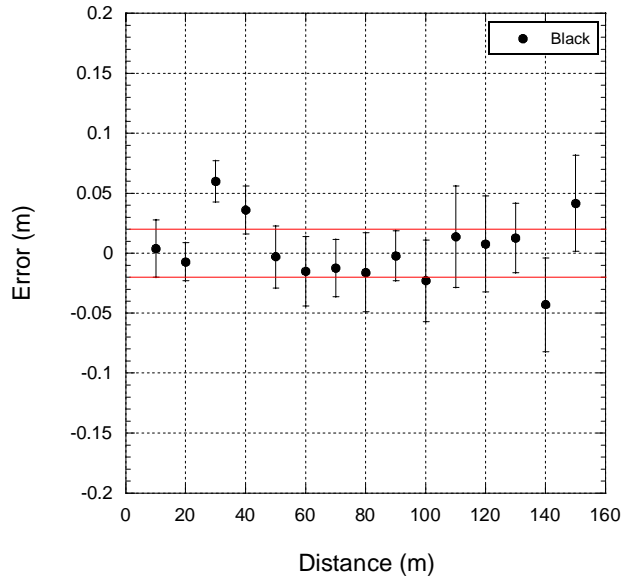
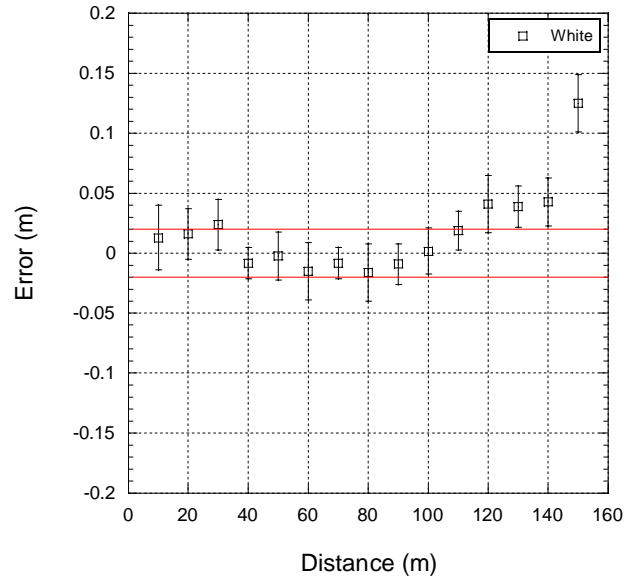

Figure 3.8. Data Set 5: Standard Deviation of Error of Laser Measurements.

Figures 3.9a to 3.9d break out the data from Figs. 3.7 and 3.8, a color at a time. The figures display clearly the degraded accuracy of the LDP target at 0 m to 40 m, and again, the roughly linear rise of the LDP error from negative to positive bias. While the silver and black targets results appear relatively tame, the accuracy for the white target decreases steadily for distances beyond 120 m. Again, the error bars of Fig. 3.9a clearly show that the black target is noisier than the other targets in the 80 m to 150 m range. This decrease in precision with increase distance was also noted in Data Set 4; however, this phenomenon was noted for all targets – black, white, and green – and not just for the black target as is the case in Data Set 5.



a. Black



b. White

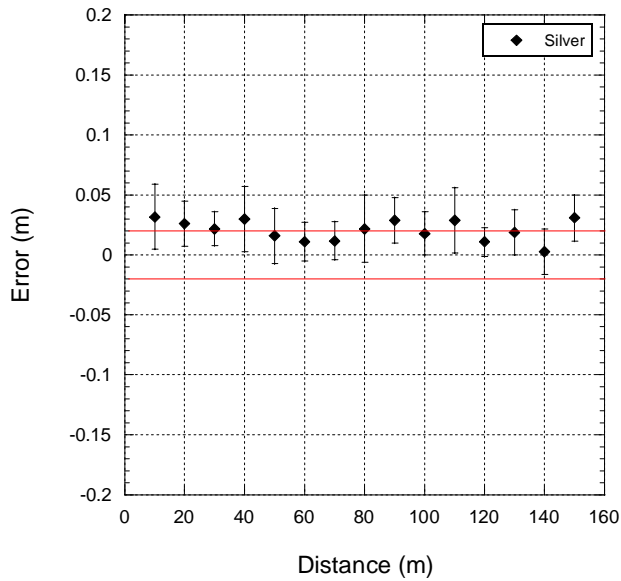

c. Silver

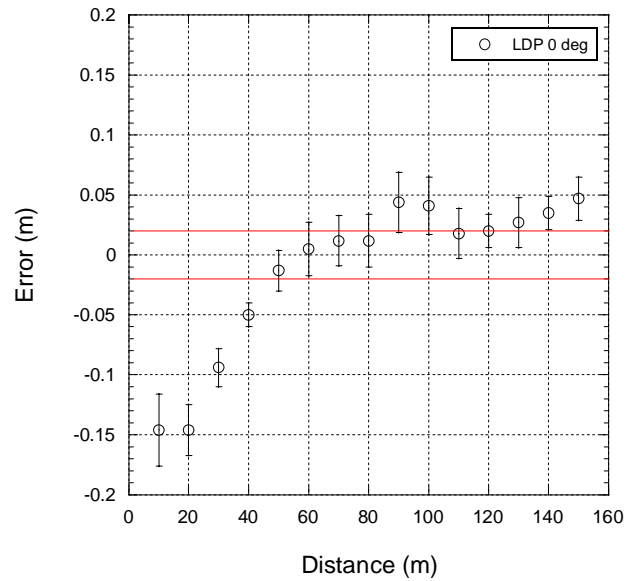

d. LDP, 0°

Figure 3.9. Data Set 5: Error Plots (Error bars = 1σ).

Summary of Data Set 5: Effects appear both in the consideration of localized precision statistics and overall residual error, and very noticeable effects are seen on accuracy, particularly in the case of the LDP target. It is clear that reflectance properties can have very real effects on the accuracy of the distance measurements.

3.1.4 Combined Data Sets

Figures 3.10a and 3.10b show the errors and standard deviations for white and black targets cumulated from Data Sets 1 to 6. From Fig. 3.10a, there is no pronounced black versus white effect although about half of the data fall outside the specified instrument accuracy. In Fig. 3.10b, a clear pattern can be discerned. The measurements of white targets are noisier in the 0 m to 50 m range while the black targets are noisier in the 60 m to 150 m range with a linear increase above the 100 m range. In fact, it appears that the repeatability for the white targets goes roughly linearly down across the range of distances presented by the data while the repeatability for the black targets goes approximately linearly up.

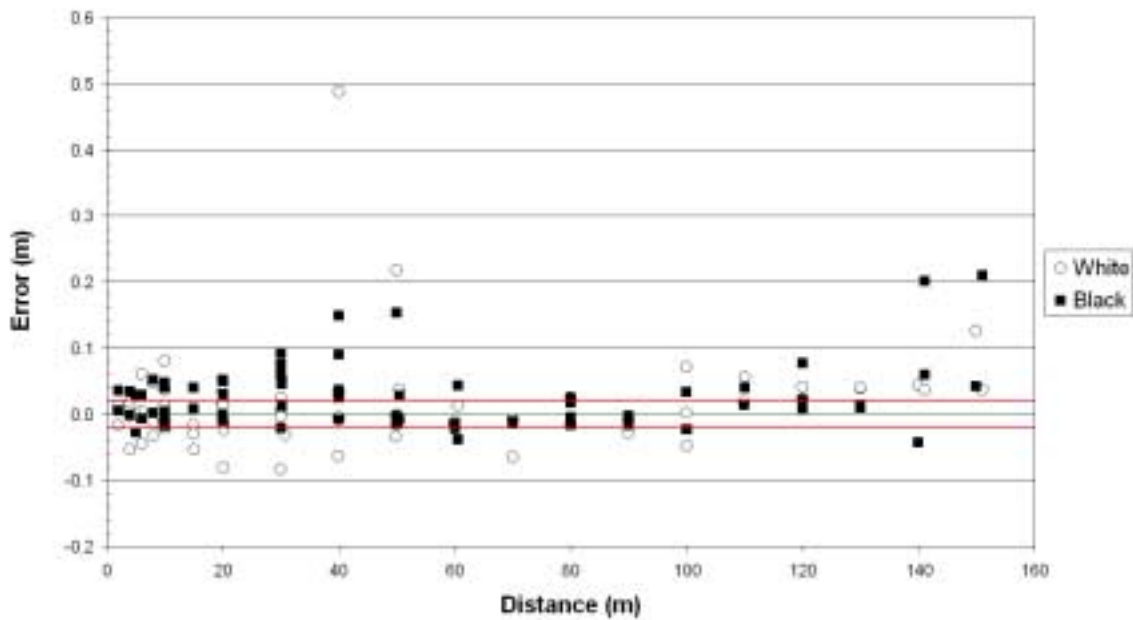

Figure 3.10a. Combined Errors for White and Black Targets from Data Sets 1 to 6.

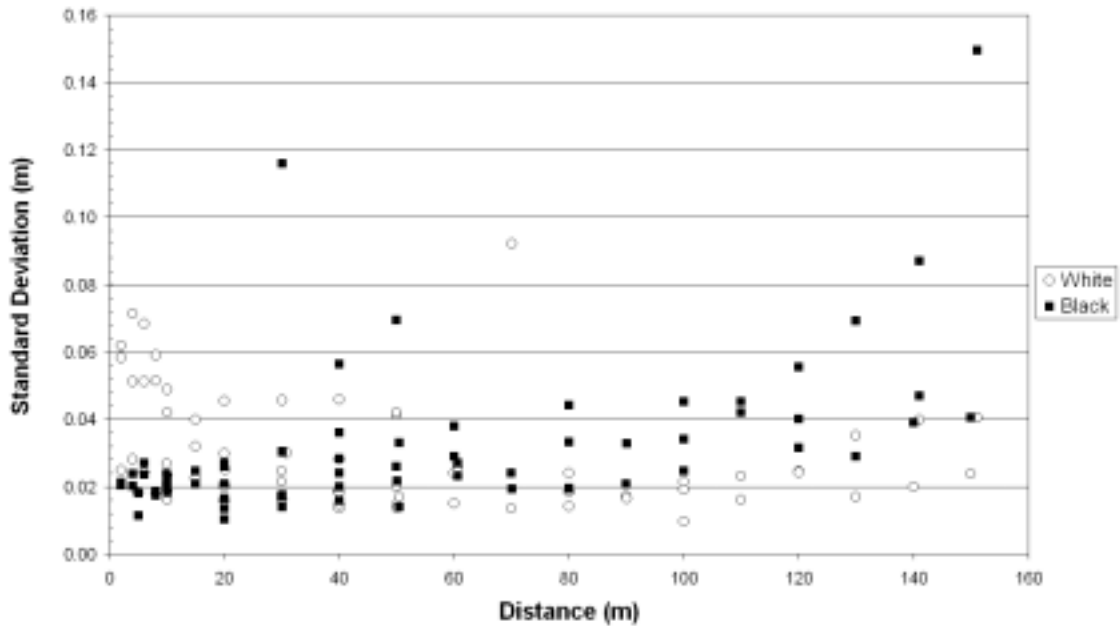

Figure 3.10b. Standard Deviations for White and Black Targets from Data Sets 1 to 6.

3.2 Intensity

A plot of the intensity versus distance to the target is shown in Fig. 3.11. As seen in Fig. 3.11, the intensity values for the LDP target at 0° are consistently high – 200 to 250 over the entire range of the scanner – and are easily distinguishable from the other targets. As expected, the intensity values drop off when the target is turned 45° away from the scanner - the intensity values for the LDP target at 45° are very similar to those for the shiny silver target at 0° and one could be mistaken for the other. At an angle of incidence of 60° , the intensity values for a LDP target would be indistinguishable from values for the white target. Although stratification of the intensities for white and LDP at 60° targets can be seen in Fig. 3.11, it would be hard to determine the color/reflectance of the object struck for each point in a scene. For example, an intensity value of about 90 could be for a point off an LDP target rotated at 60° at 120 m or a white target at 80 m or a black target at 20 m. Thus, without additional information, one would not be able to determine if the target was white, black or LDP rotated at 60° . Also, as mentioned in Section 2.2.4, the intensity values also depend on the lighting conditions and would likely be different in bright sunlight or in shadow.

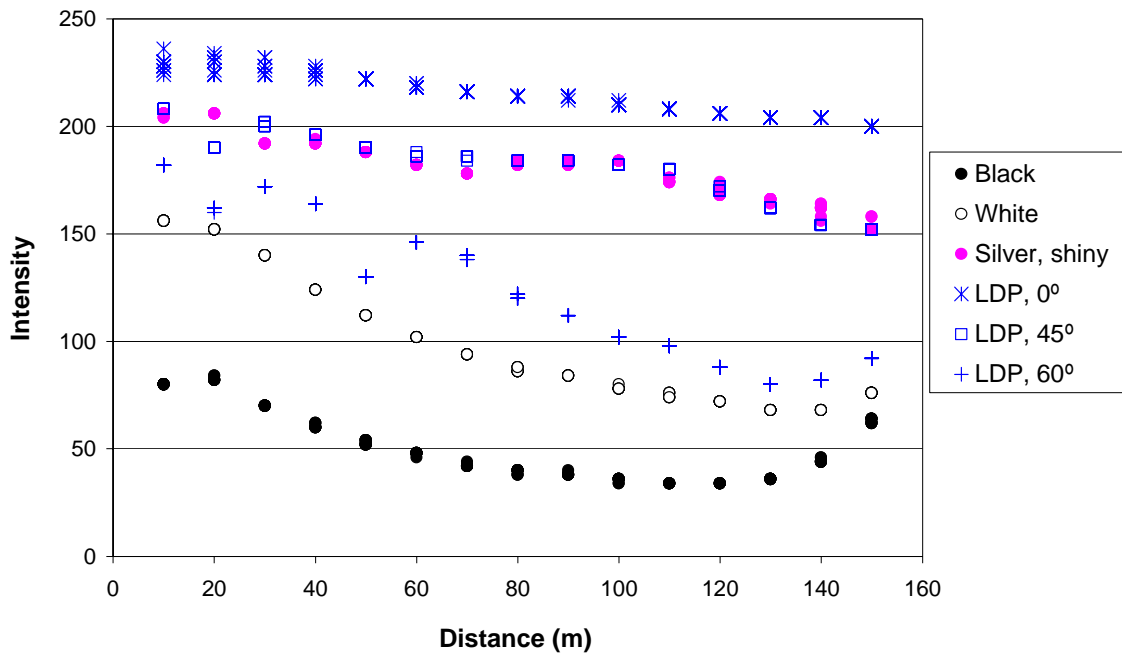

Figure 3.11. Data Set 5: Intensity vs. Distance.

In Fig. 3.11, the intensity values for the black, white, and LDP at 60° targets are increasing at distances of 140 m and 150 m which is contrary to what would be expected. This increase may be attributed to the contribution of the white wall behind the target at the longer distances. The wall was located about 160 m from the scanner.

The intensities from Data Set 6 are plotted in Figs. 3.12a to 3.12c. The actual intensity values from this data set are very similar to those from Data Set 5 and show the same sort of trends for the white, black, and silver targets, with the silver target displaying the most pronounced stratification, especially at angle of incidences of 0° and 10°. In Fig. 3.12c, the intensities for the targets at higher angles of incidence appear to increase as the distance increases. This increase in intensity is due to the fact that a larger portion of the beam is being reflected back off the white wall behind the target at the higher angles of incidence.

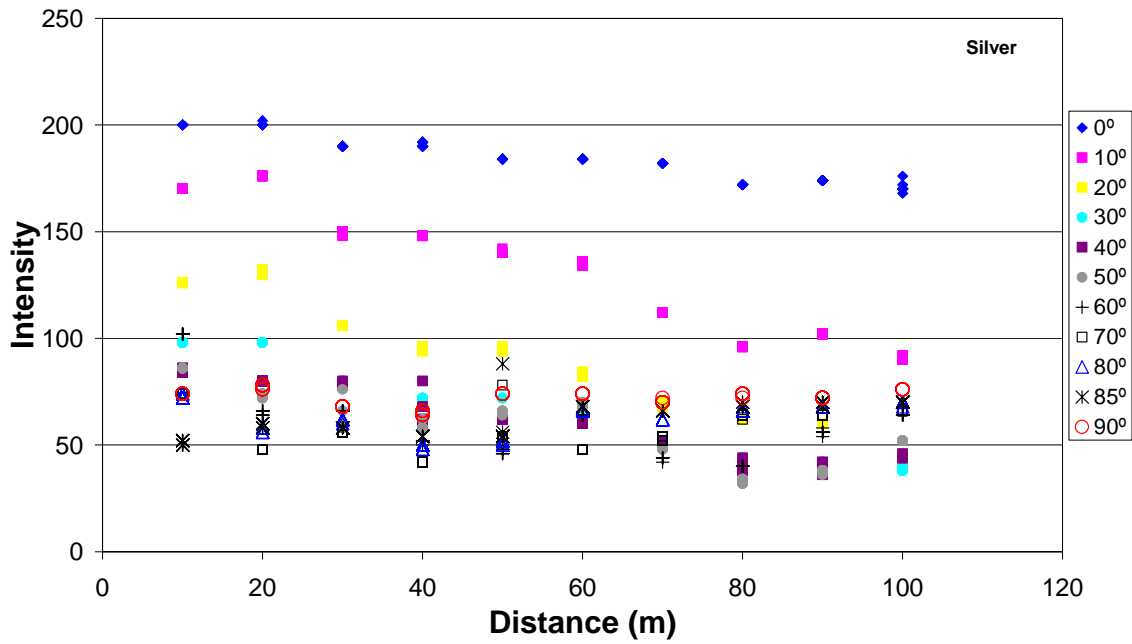

Figure 3.12a. Data Set 6: Silver Target Intensity as a Function of Distance and Angle of Incidence.

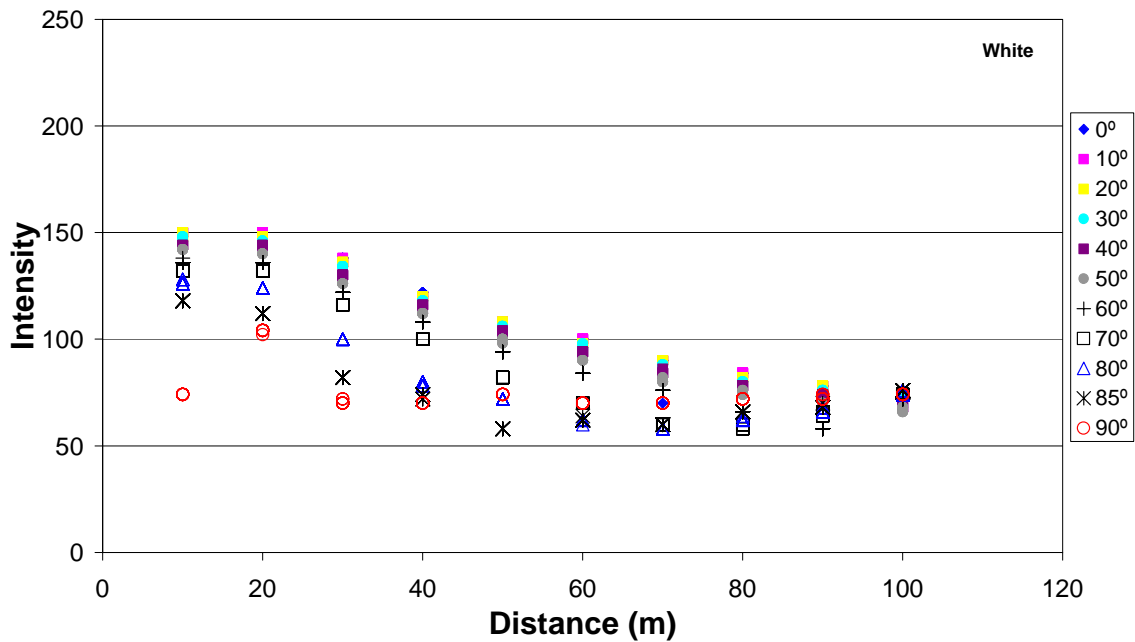

Figure 3.12b. Data Set 6: White Target Intensity as a Function of Distance and Angle of Incidence.

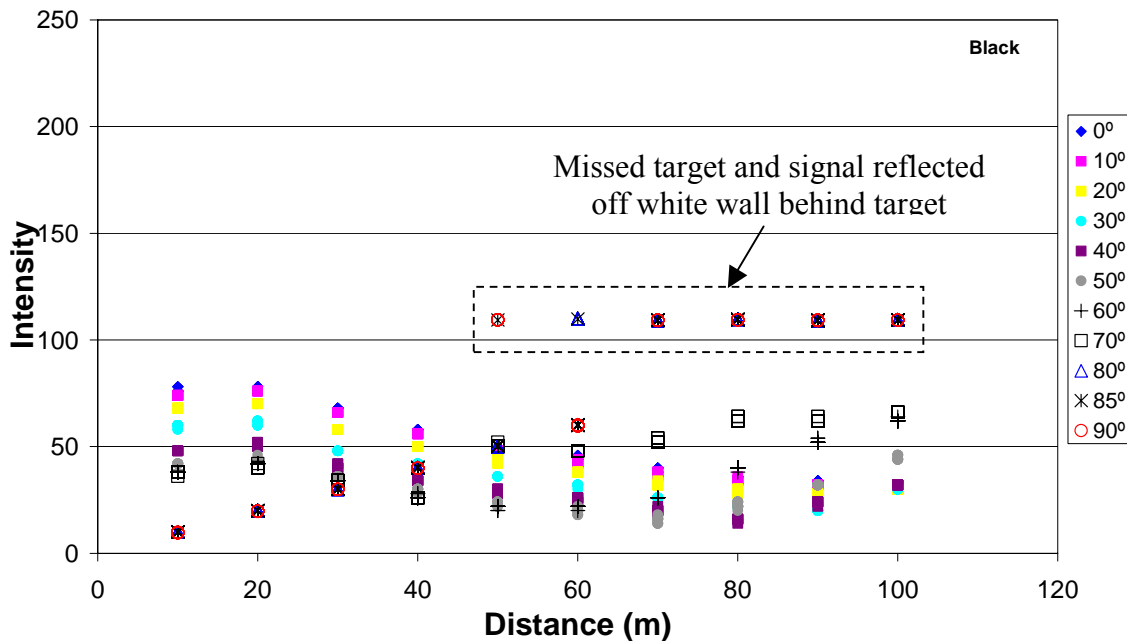

Figure 3.12c. Data Set 6: Black Target Intensity as a Function of Distance and Angle of Incidence.

Summary for Intensity data: The objective of these experiments was to find a material which would yield consistently high intensity values for the entire range of the scanner. A clear effect is seen on intensity as a function of reflectance – targets with high reflectance yield higher intensities. However, the intensities degrade with increasing distance. On the other hand, the LDP targets at 0° and 45° show less degradation than the other targets and yield consistently high intensities for all distances – making these targets easily distinguishable from other targets. These results are encouraging and indicate that the LDP material could potentially be used to fabricate bar codes or tags that can be read by a LADAR.

3.3 Angle of Incidence

3.3.1 Data Set 6

For each rotation angle (angle of incidence) and for each target color, the measured distances were plotted against the actual distance (10 m to 100 m). For each of these plots, least squares regression lines were fitted through the points. The standard deviations of the residuals (averaged case) from the fitted line are given in Table 3.4 and plotted in Fig. 3.13. In Fig. 3.13, the maximum scale of the Y-axis was set to 1 m, and the residual standard deviations for the silver target at 80° and 85° rotation are greater than 1 m and are therefore not shown.

Table 3.4. Residual Standard Deviation from Linear Regression.

Rotation Angle (°)	Residual Standard Deviation (m)		
	White	Black	Silver
0	0.0348700	0.0268980	0.0206252
10	0.0221700	0.0290150	0.0238604
20	0.0227700	0.0362710	0.0667554
30	0.0220900	0.0404220	0.3260688
40	0.0230400	0.0765750	0.1136327
50	0.0422800	0.0598770	0.4613150
60	0.0642100	0.0592890	0.5549653
70	0.0548600	0.0769410	0.6897836
80	0.0480000	0.0793640	2.5933830
85	0.0632800	0.0853410	5.0056010
90	0.0769480	0.1027240	0.0945438

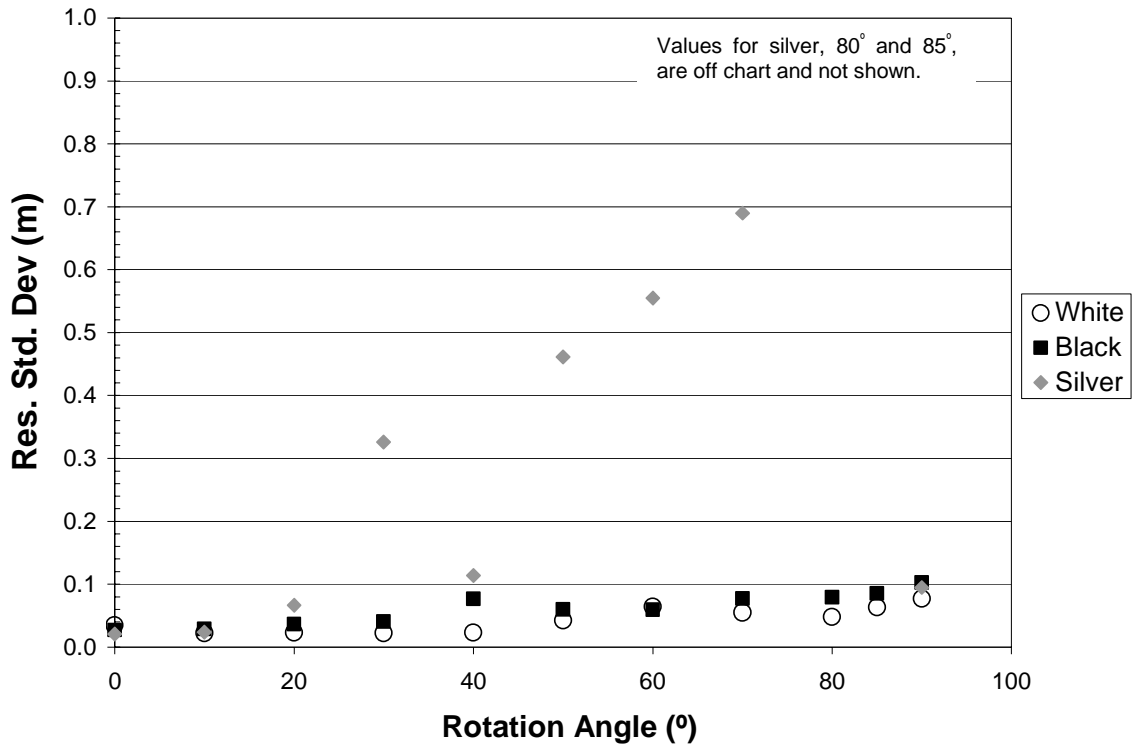

Figure 3.13. Data Set 6: Residual Standard Deviation.

From Table 3.4 and Fig. 3.13, it is seen that for the white target, the residual standard deviation exceeded the nominal instrument accuracy for angles of incidence greater than 40°. Slightly degraded performance is noted for the black and silver targets. For incidence angles greater than 10°, the residual standard deviations for the silver and black targets are greater than the stated accuracy of the instrument (± 2 cm). However, the residual standard deviations for the silver

target are significantly greater than those for the black target for angles of incidence between 30° and 85° (see discussion later in this section).

As seen in Table 3.5, it appears that the number of misses depends on the color of the target with the black target (least reflective) sustaining the most misses followed by the silver and then the white. A “miss” is defined as a laser measurement equal to 109 m; 109 m is the distance from the LADAR to the wall behind target. In the case of the black target, the strength of the return signal was insufficient or below a threshold value required to trigger the detector whereas the strength of the return signal off the wall behind the target was sufficient, i.e., the black target absorbed more energy than the white wall. For the black target, partial misses (less than 10 repetitions) began occurring at angle of incidence of 50° to 60° for a distance of 80 m. Total misses (10 repetitions) began occurring at angles of incidence greater than 70° for distances of 70 m and 80 m and 50° for distances of 90 m and 100 m.

Table 3.5. Number of Target Misses.

Distance (m)	Angle of Incidence (°)											
	0	10	20	30	40	50	60	70	80	85	90	
Black												
10	0	0	0	0	0	0	0	0	0	0	0	0
20	0	0	0	0	0	0	0	0	0	0	0	0
30	0	0	0	0	0	0	0	0	0	0	0	0
40	0	0	0	0	0	0	0	0	0	0	0	0
50	0	0	0	0	0	0	0	0	0	0	1	10
60	0	0	0	0	0	0	0	0	0	10	1	0
70	0	0	0	0	0	0	0	10	10	10	10	10
80	0	0	0	0	0	5	9	10	10	10	10	10
90	0	0	0	0	0	10	10	10	10	10	10	10
100	0	0	0	0	1	10	10	10	10	10	10	10
Silver												
10	0	0	0	0	0	0	0	0	0	0	0	0
20	0	0	0	0	0	0	0	0	0	0	0	0
30	0	0	0	0	0	0	0	0	0	0	0	0
40	0	0	0	0	0	0	0	0	0	0	0	0
50	0	0	0	0	0	0	0	0	0	0	0	8
60	0	0	0	0	0	0	0	0	0	0	0	0
70	0	0	0	0	0	0	0	0	0	0	0	0
80	0	0	0	0	0	0	0	2	0	0	0	0
90	0	0	0	0	0	0	0	6	0	0	0	0
100	0	0	0	0	0	0	9	10	10	10	10	0
White												
10	0	0	0	0	0	0	0	0	0	0	0	0
20	0	0	0	0	0	0	0	0	0	0	0	0
30	0	0	0	0	0	0	0	0	0	0	0	0
40	0	0	0	0	0	0	0	0	0	0	0	0
50	0	0	0	0	0	0	0	0	0	0	0	0
60	0	0	0	0	0	0	0	0	0	0	0	0
70	0	0	0	0	0	0	0	0	0	0	0	0
80	0	0	0	0	0	0	0	0	0	0	0	0
90	0	0	0	0	0	0	0	0	0	0	0	0
100	0	0	0	0	0	0	0	0	0	0	0	2
<div style="display: flex; gap: 10px;"> <div style="display: flex; align-items: center;"> <div style="width: 15px; height: 10px; background-color: #cccccc; border: 1px solid black; margin-right: 5px;"></div> All Misses </div> <div style="display: flex; align-items: center;"> <div style="width: 15px; height: 10px; background-color: #e0e0e0; border: 1px solid black; margin-right: 5px;"></div> Partial Misses </div> </div>												

The errors as a function of distance and angle of incidence for each of the three targets are shown in Figs. 3.14a to 3.14c and Figs. 3.15a and 3.15b. The scales for the plots in Fig. 3.14 were set to be equal for ease of comparison. The data in Fig. 3.14 are re-plotted in Fig. 3.15 with enlarged scales for the black and white targets. From the plots, it can be seen that, in general, the accuracy decreases as the angle of incidence increases and more specifically, it can be seen that:

1. The silver target yields the largest measurement errors and displays a clear angle of incidence effect on bias that is monotonically decreasing in angle from 80° down to 30°. It is especially evident, both in terms of magnitude of the bias and clean stratification of biases between angles, for angles of incidences of 50° and higher.

There might be two possible explanations for the large errors for the silver target. In both of these hypothesized cases, the return signal is affected by external objects such as walls

around the target. In the first case, the errors may result from splitting of the signal whereby a portion of the signal hits the target with the remaining signal hitting the wall behind the target (see Section 2.6). The size of the target was selected so that the target was larger than the laser beam at the maximum range of the scanner (150 m). However, as the target is turned, the target area, as seen by the scanner, is reduced and may result in a split signal. The split signal phenomenon does not, however, appear to be contributing to the error in this situation as the errors are only observed for the silver target and not for the white or black targets. This hypothesis is therefore rejected. In the second case, it is assumed that a portion of the signal reflected off the specular target hits an object or wall to the side of the target and is returned to the scanner. In this case, the distance to this object or wall is included in the reported distance measurement – biased high or longer reported distances. This appears to be the case for the silver target as seen in Fig. 3.14a.

2. The magnitude of the errors for angles of incidence of $\leq 30^\circ$ is similar for all targets but the errors for the silver target (highest reflectance) are greater thereafter.
3. For an angle of incidence of 90° , the target as seen by the LADAR is a strip approximately 1 mm wide. The distance from the target should ostensibly be shorter by half the width of the target (0.4 m wide), i.e., the measured distance should be compared to the true distance minus 0.2 m. This accounts for the consistently negative biases of the 90° measurements for all three targets.

The averages of the errors (10 m to 90 m) for an angle of incidence of 90° are $-0.312 \text{ m} \pm 0.079 \text{ m}^\dagger$ for silver, $-0.257 \text{ m} \pm 0.070 \text{ m}$ for white, and $-0.232 \text{ m} \pm 0.053 \text{ m}$ for black. Even after half the width of the target is taken into account, the errors are still large, but it is interesting that the instrument can differentiate an object approximately 1 mm wide even at 100 m.

4. For the white target, at distances greater than 60 m, the errors appear to be increasing (in the negative direction) almost exponentially (Fig. 3.15a) for the higher angle of incidences.
5. For the black target, there are minor angle of incidence effects. There is some stratification at angles of incidence of 50° and greater (Fig. 3.15b).

A portion of the error at the higher angles of incidence for all targets may be attributed to the inherent procedure used to determine the range. The LADAR used in these experiments is a time-of-flight instrument. That is, the range is determined by measuring the return time, t , of a signal and is approximately equal to $(c \cdot t/2)$ where c = speed of light and $(t/2)$ instead of t as t is the total return time. For the LADAR used in these experiments, an “averaging” of the signal return times occurs when no spike or distinct peak in the return signal is detected. For the case when the target is turned away from the scanner, the scanner detects several signal returns (returns from closest point to the farthest point on the angled target) or return times and an average time is recorded. This type of error is instrument specific and cannot be quantified

[†] Values following “ \pm ” represent one standard deviation.

unless more information is known about the method used to average the signal return times and further experiments are conducted. The required instrument information is usually not available from the manufacturer for proprietary reasons.

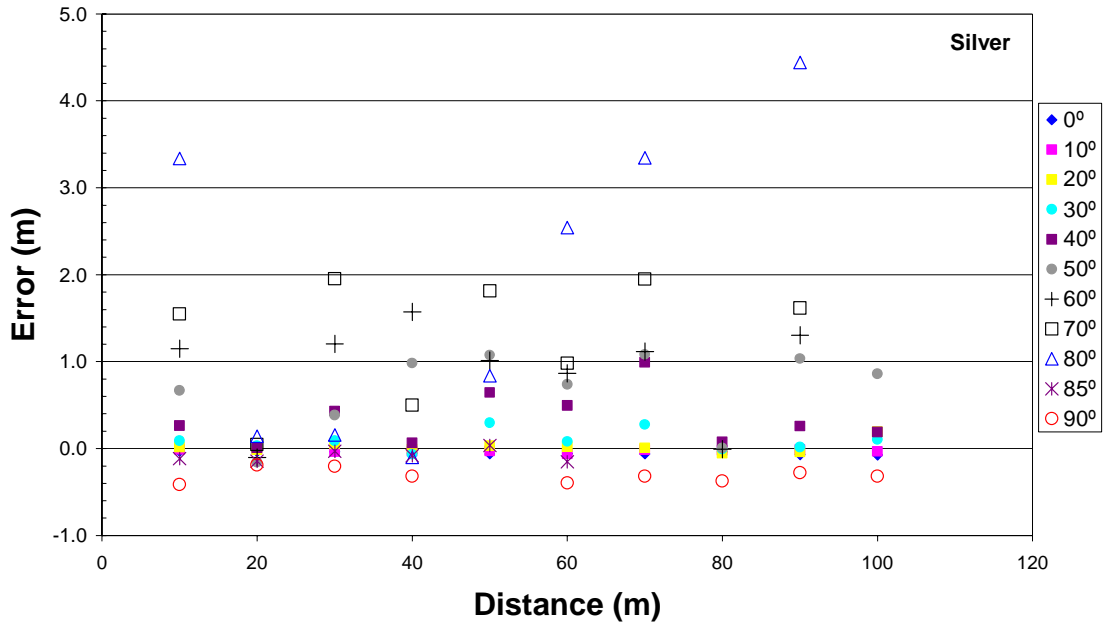

Figure 3.14a. Data Set 6: Silver Target – Error vs. Distance and Angle of Incidence.
 Note: Errors greater than 5 m not shown.

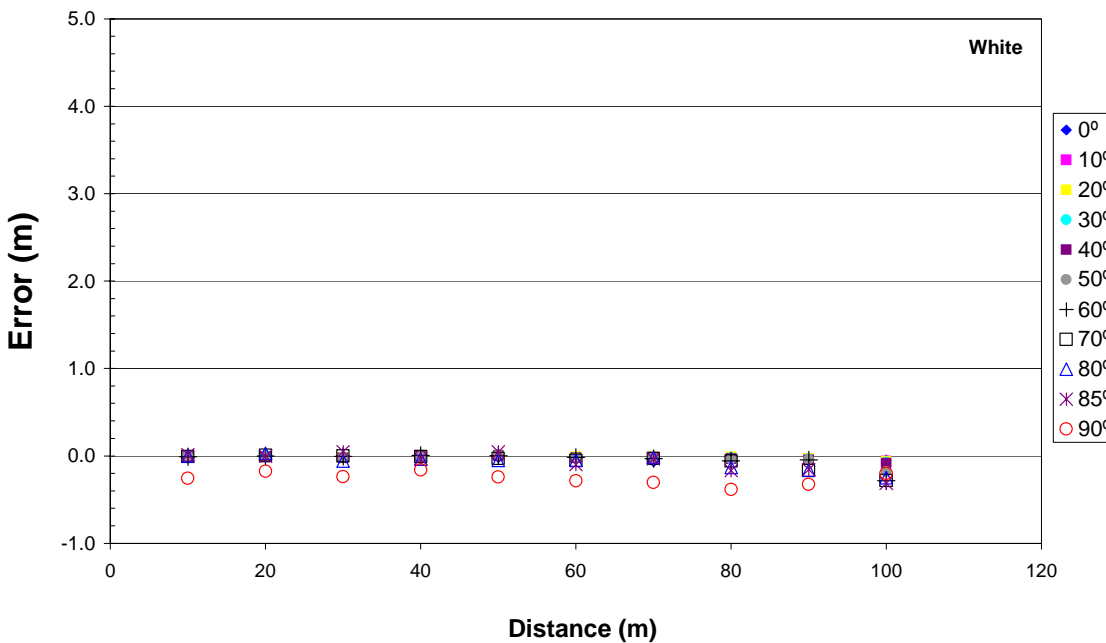

Figure 3.14b. Data Set 6: White Target – Error vs. Distance and Angle of Incidence.

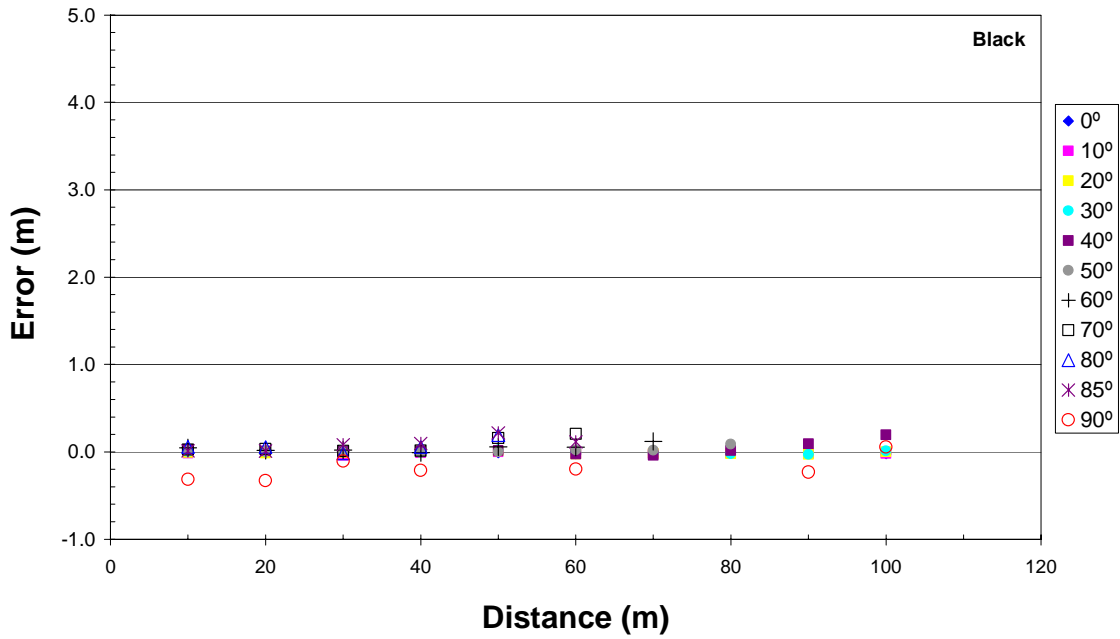

Figure 3.14c. Data Set 6: Black Target – Error vs. Distance and Angle of Incidence.

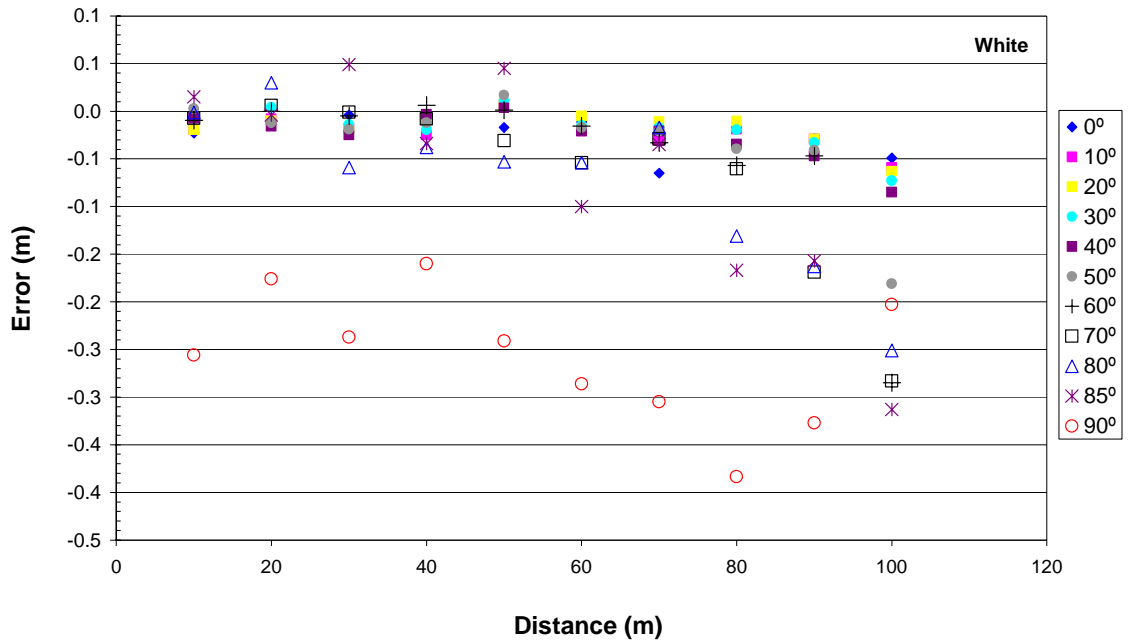

Figure 3.15a. Data Set 6: White Target – Error vs. Distance and Angle of Incidence. (Enlarged scale for Fig. 3.14b)

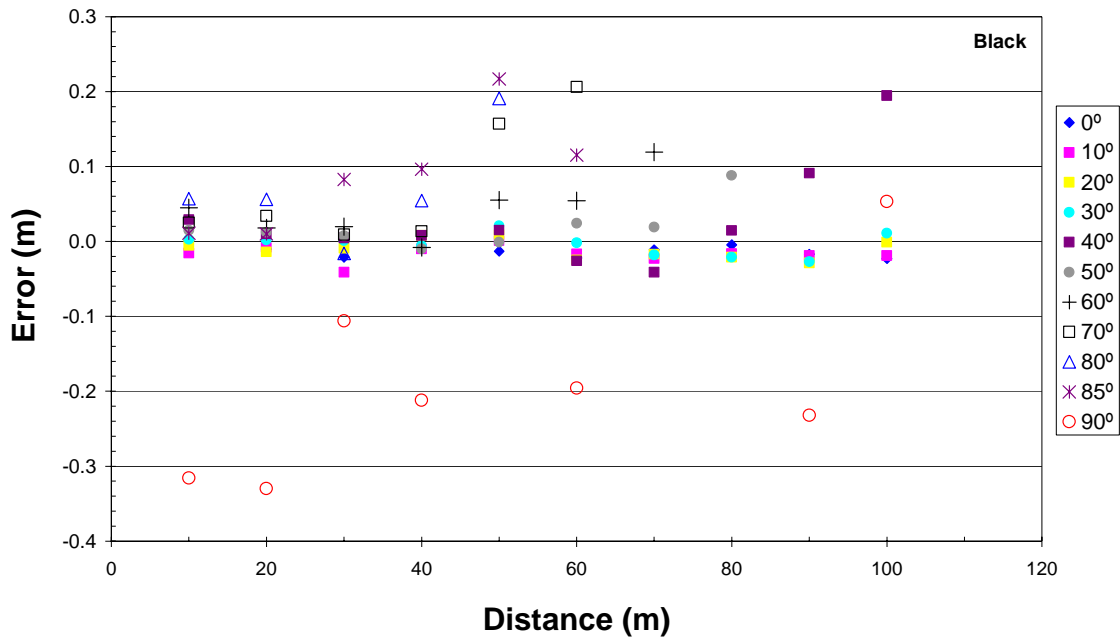

Figure 3.15b. Data Set 6: Black Target – Error vs. Distance and Angle of Incidence. (Enlarged scale for Fig. 3.14c)

The standard deviations of the errors for Data Set 6 are shown in Figs. 3.16a to 3.16c. It is clear from these plots that the silver target is the noisiest followed by the black target with the white target being the least noisy. Both the silver and black target show a pronounced effect in terms of noise as a function of angle of incidence and distance although the stratification in terms of angle of incidence is not perfectly clean nor is there any immediately obvious monotonicity in terms of magnitude of angle. For distances of 20 m and greater, the noise seems to increase almost exponentially for high angles of incidence for the silver.

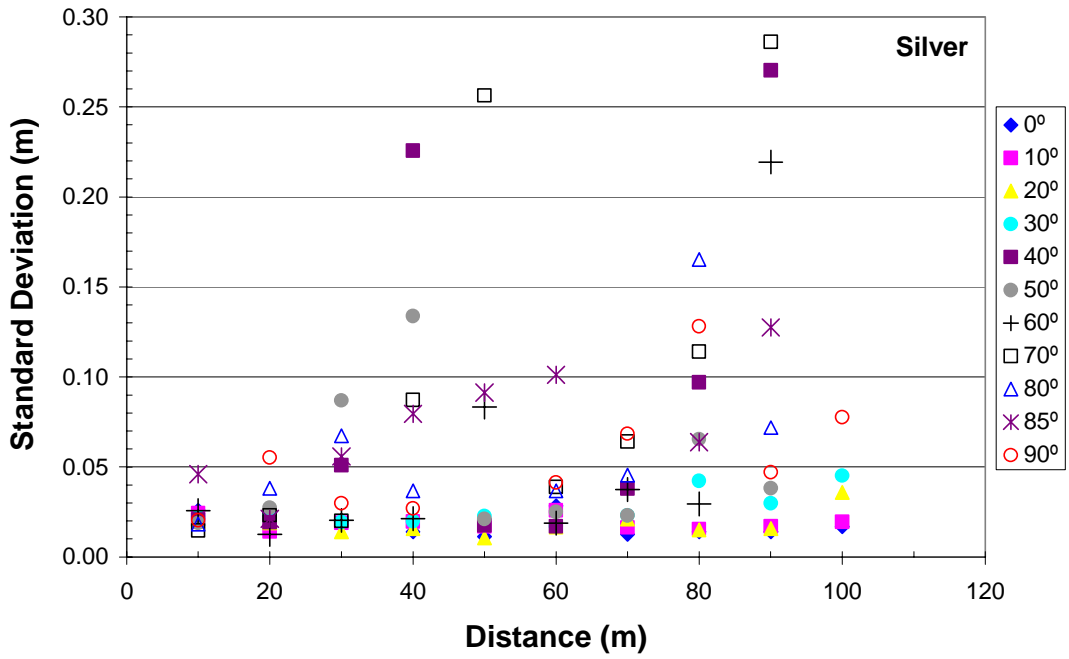

Figure 3.16a. Data Set 6: Standard Deviation of Error for Silver Target.

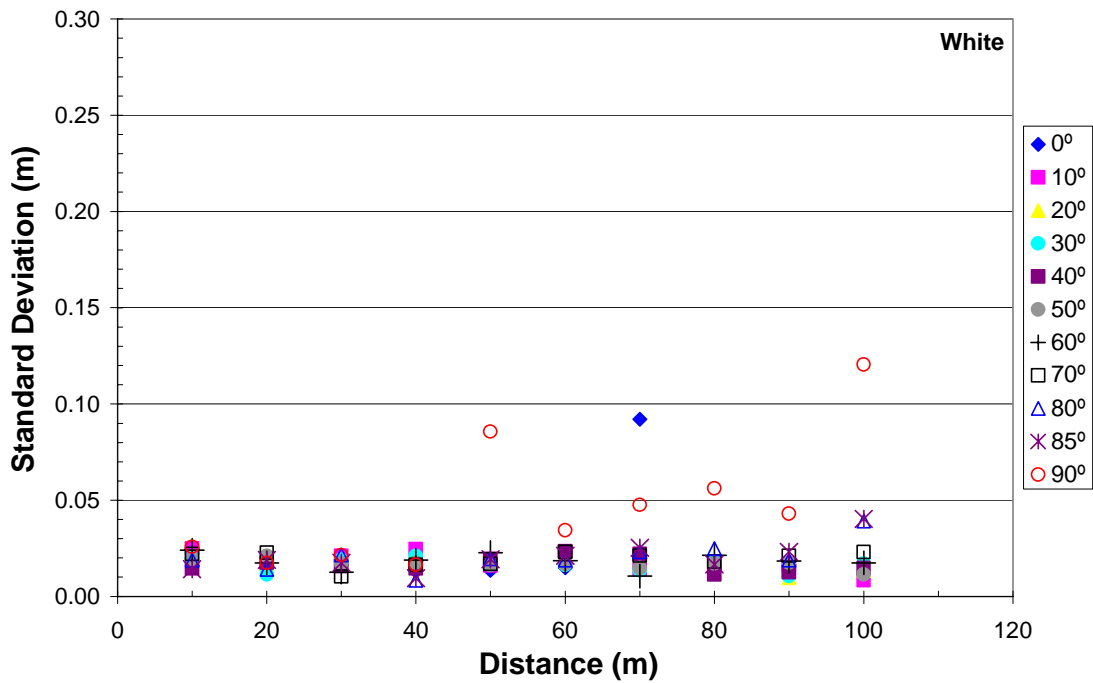

Figure 3.16b. Data Set 6: Standard Deviation of Error for White Target.

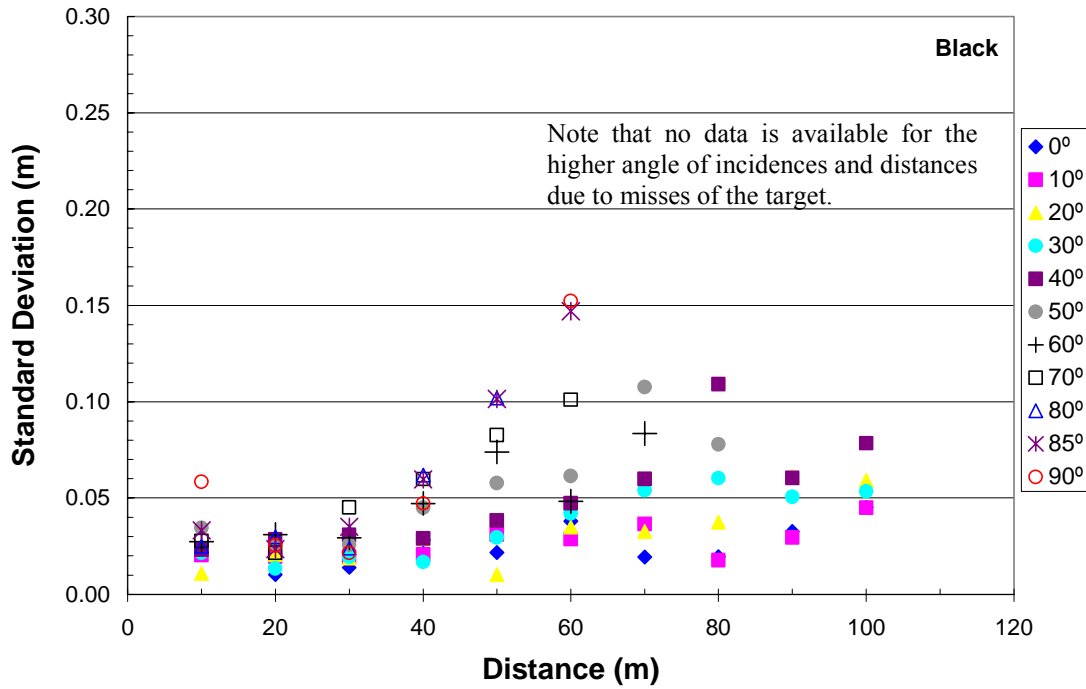
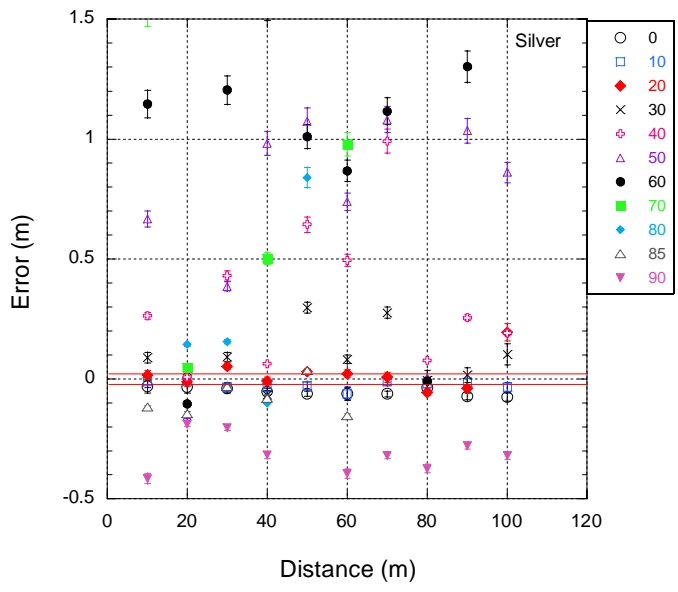
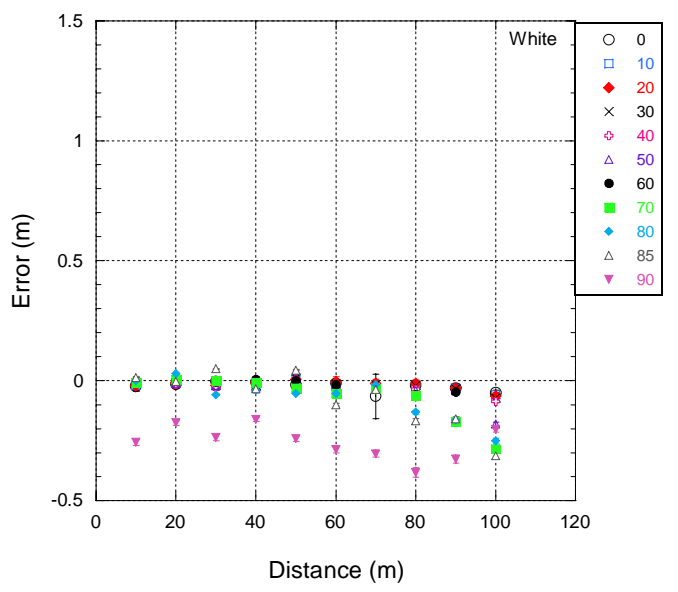

Figure 3.16c. Data Set 6: Standard Deviation of Error for Black Target.

Figures 3.17 and 3.18 combine the data from Figs. 3.15 and 3.16 and show the data for each color separately. In these figures, the values in the legend represent the angular rotation of the target in degrees.



a. Silver



b. White

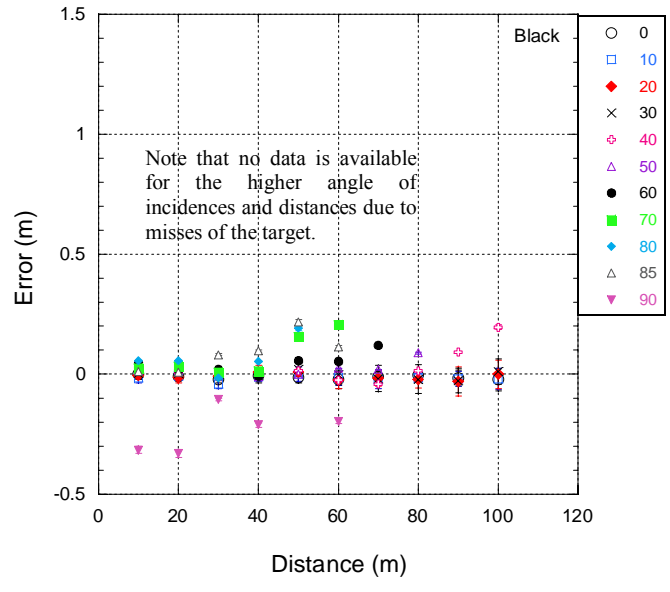

c. Black

Figure 3.17. Data Set 6: Error vs. Distance and Angle of Incidence. Values in legend represent target rotation in degrees. (Error bars = 1σ).

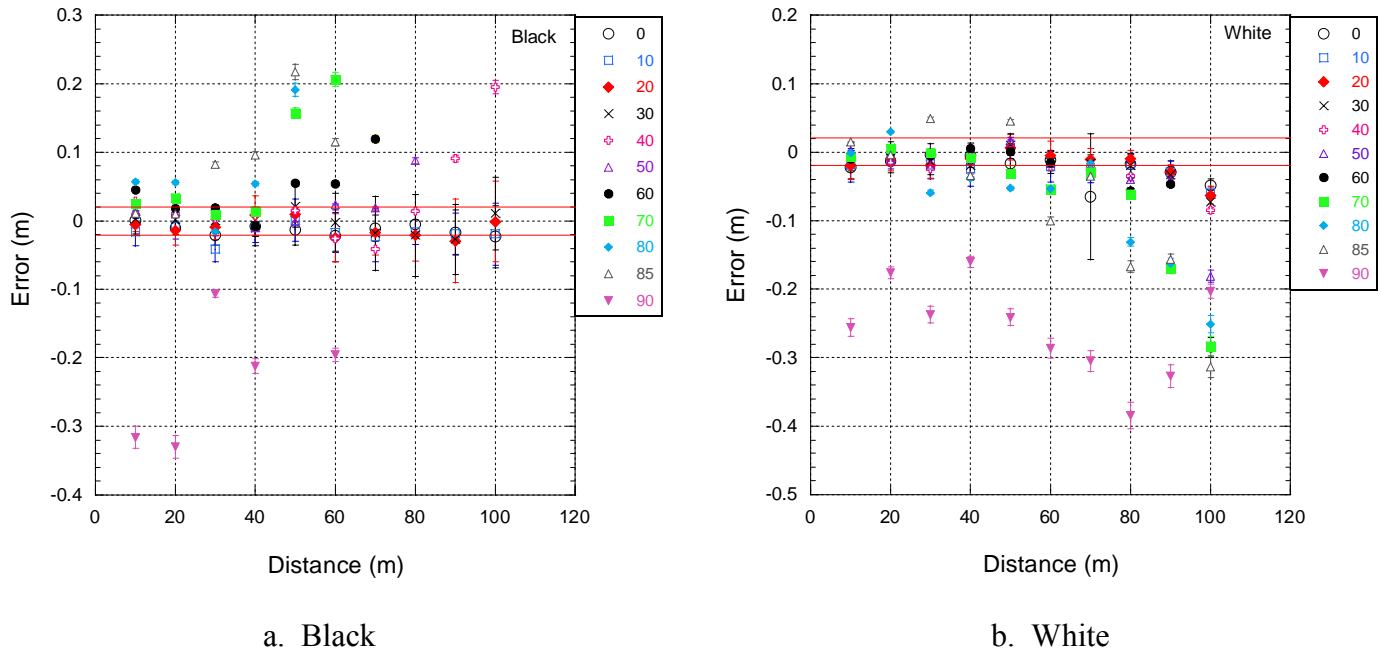

Figure 3.18. Data Set 6: Error vs. Distance and Angle of Incidence: Enlarged scale as compared with Figs. 3.17b and c. Values in legend represent target rotation in degrees. (Error bars = 1σ).

3.3.2 Data Sets 5 and 6

The data for the LDP target (Data Set 5) for three angles of incidence (0° , 45° , 60°) are shown in Fig. 3.19a. Other than the observation made in Section 3.1 that high reflectance of the LDP target at 0° causes significant error for distances less than 40 m, no clear effect in terms of accuracy or precision as a function of angle of incidence, can be observed for the LDP target. The LDP target at 45° exhibits somewhat degraded accuracy for the mid-distances, 80 m to 110 m.

Also, shown in Fig. 3.19b for comparison purposes are the data for the silver target (Data Set 6). The silver target, which is less reflective than the LDP target, exhibits greater error than the LDP target for higher angles of incidences. This appears to contradict the observation made earlier that errors for more reflective targets arise from the presence of objects around the target. A possible explanation for this apparent contradiction may be because the LDP material consists of many small individual highly reflective prisms (Fig. 2.2 b). The material is manufactured in this manner (maximum visibility) so that light is reflected back to an observer even if the target is rotated away from the observer.

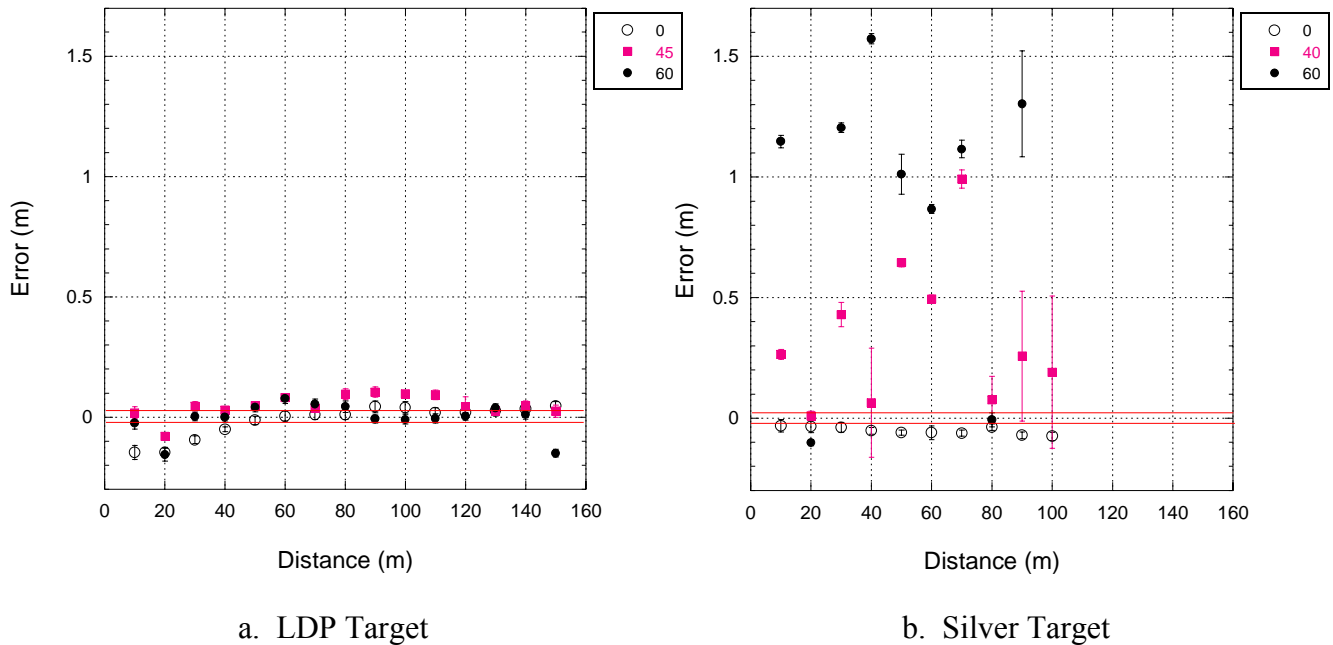

Figure 3.19. Error vs. Distance and Angle of Incidence for LDP Targets (Data Set 5) and Silver Target (Data Set 6). Values in legend represent target rotation in degrees. (Error bars = 1σ).

Summary of findings for angle of incidence: As expected, the accuracy and precision decrease as the angle of incidence increases, with the silver target (most reflective) yielding the greatest errors and being the least precise. There is no clear pattern for the effect of reflectance on precision. However, reflectance is seen to have an effect on the number of misses of a target with a lower reflectance target sustaining more misses at higher angles of incidence and at larger distances.

3.4 Beam Divergence

A useful byproduct of the angle of incidence experiment (Data Set 6) is the data of the laser beam size as a function of distance from the target. This information can be used to determine the beam spread function[‡] and the divergence of the laser beam. A laser producing a smaller output beam diameter with minimum divergence will yield more accurate distance measurements as the reported distance is averaged over the illuminated area.

The laser in the scanner is comprised of three laser diodes. The beam size as it exits the LADAR is 42 mm (high) x 25 mm (wide) as stated by the manufacturer. The results of the experiment show that the projections of the laser are one bright rectangular region for distances less than

[‡] The beam spread function is necessary for the deconvolution of the LADAR intensity image which allows for the identification of the image or “reading” of the bar codes. This topic is the subject of another NIST internal report (in preparation).

10 m. For distances greater than 10 m, three bright vertical bands with dark regions in between are visible.

The visual procedure to determine beam sizes is as follows (recall that the outlines of the laser beam were made by at least two observers using different color markers):

1. Make two copies of original outlines (or as many copies as there are observers).
2. Draw first line to best fit Observer's 1 markings – Line 1 (Fig. 3.20). Note: Line 1 was arbitrarily chosen – Lines 2, 3, or 4 could easily have been chosen as the first line to be drawn.
3. Draw a second line 90° to Line 1 that best fit markings – Line 2.
4. Draw a third line 90° to Line 2 that best fit markings – Line 3.
5. Draw a fourth line 90° to Line 3 that best fit markings – Line 4.
6. Draw lines 5-8 perpendicular to Line 2 or Line 4.
7. Measure lengths of lines.
8. Repeat Steps 2 to 7 for Observer 2's outlines.

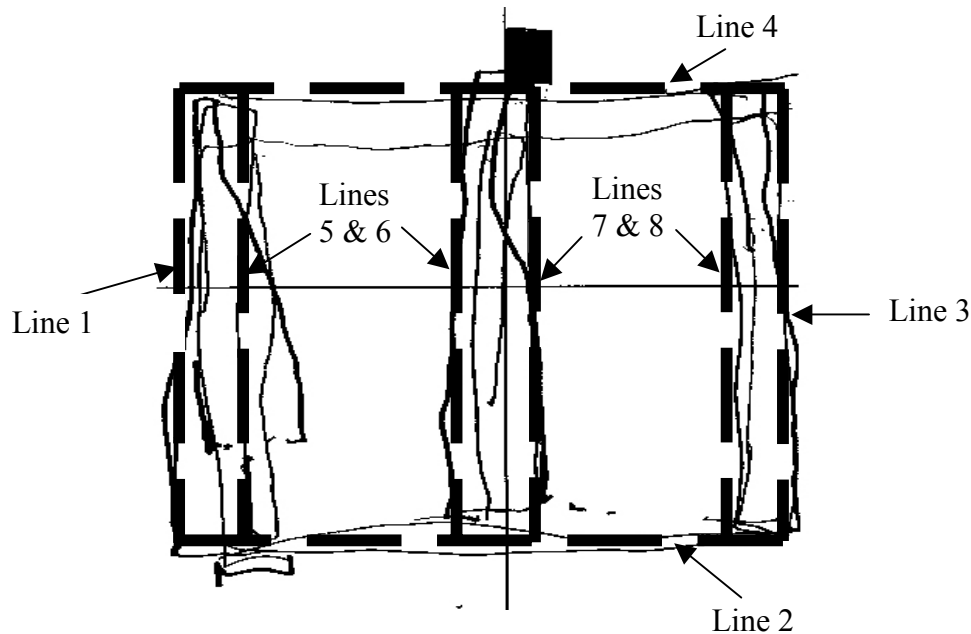

(a) Observer 1 (Drawing has been reduced and is not shown to scale).

Figure 3.20. Outline of Laser Beam at 70 m.

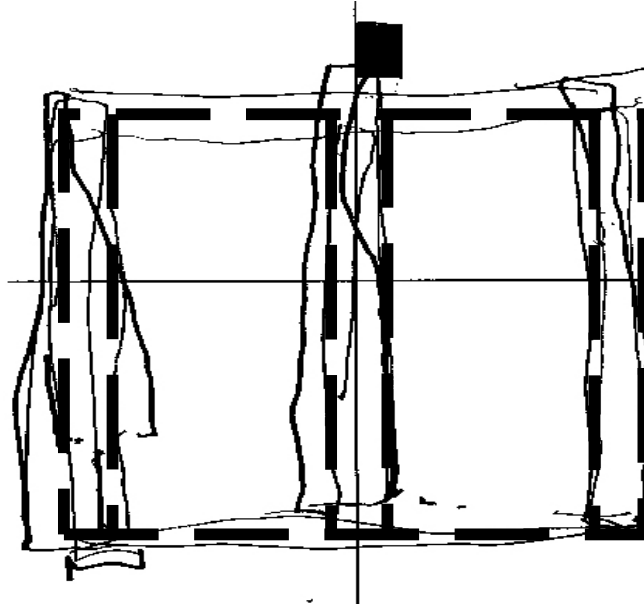

(b) Observer 2 (Drawing has been reduced and is not shown to scale).

Continue Figure 3.20. Outline of Laser Beam at 70 m.

The beam dimensions as obtained from the procedure described above are given in Table 3.6.

Table 3.6. Data Set 6: Laser Beam Size.

Distance (m)	L [†] (mm)	W [†] (mm)	a [†] (mm)	b [†] (mm)	c [†] (mm)	d [†] (mm)	e [†] (mm)
2 [§]	17	41	na ^{††}	na	na	na	na
2 [§]	15	45.5	na	na	na	na	na
2 [§]	15	47	na	na	na	na	na
2 [§]	17	40	na	na	na	na	na
2 [§]	14	41	na	na	na	na	na
5 [‡]	19	42	na	na	na	na	na
5 [§]	25	46	na	na	na	na	na
5 [§]	18	36	na	na	na	na	na
5 [§]	19	41	na	na	na	na	na
10 [‡]	31.5	49	15	2	10.5	1.5	20
10	27	51	na	na	na	na	na
10	28	48	na	na	na	na	na
10	22	46	na	na	na	na	na
10	29	58	na	na	na	na	na
10	24	53	na	na	na	na	na
10	31	62	na	na	na	na	na
20 [‡]	60	68	19.5	8	16	10	14
20	53.5	68	9.5	16.5	14	14	14
20	55	56	9	15	14	11	8
30	86	79	7	21.5	11	29	10
30	79	87	9.5	24.5	15	34.5	3.5
30 [‡]	74.5	86	16	18	16.5	23.5	12
39.5 [‡]	117.5	116	11.5	37.5	14.5	37	15.5

Distance (m)	L [†] (mm)	W [†] (mm)	a [†] (mm)	b [†] (mm)	c [†] (mm)	d [†] (mm)	e [†] (mm)
39.5 [‡]	96	111.5	14	35.5	13	29	20
40	115	117	17	26	20.5	31	22
40	101	105	13	24	24	30	14
50	136	159	39	32.5	14	54	19
50	127	146.5	12.5	47	22	43.5	22
60	158	166.5	21	48	23	57	17
60	161	166	24.5	53	18	47	22.5
70	180	194	20	68	25.5	62.5	18
70	166	187	16	71	18	66	16
80	176	183	14	78	18	59	14.5
80	166	207	20.5	53.5	27	84	22.5
80	172	213	19.5	97	17	57.5	22.5
90	186	260	26	115.5	25	72	21
90 [§]	254	248	22.5	73	54	61	38
90 [§]	230	230	26.5	65	44.5	64.5	29.5
100	182.5	274	25	101	34	84	30
100 [§]	234	266	17	120	14.5	101	12.5
100 [§]	246.5	263.5	15	99.5	14	122	14
100 [§]	284	288.5	21	107.5	24.5	110.5	25

Notes:

[†] Description of Variables

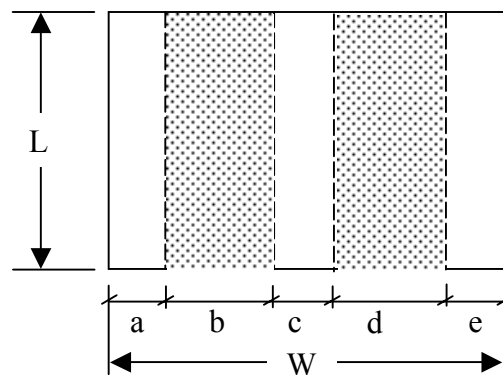

[‡] A few initial tests were made on October 11, 2001 to determine if the projection of the laser beam could indeed be seen and “measured” using an IR viewer.

[§] Additional runs were made on Feb. 26 and 27, 2002 to determine the beam size at distances where there were no data or where there was only one data point available.

^{††} na = not applicable

The lengths and widths of the beam projection are plotted as a function of the distance in Fig. 3.21. Despite the highly subjective manner in which the beam dimensions were obtained, a clear trend for the beam length and width appears visible in Fig. 3.21. Quadratic model least squares regression parameters for the width and length of the beam are:

$$\begin{aligned}
 \text{width} &= 0.0071x^2 + 1.6637x + 34.815 & R^2 &= 0.9874 \\
 \text{length} &= -0.0025x^2 + 2.528x + 6.9588 & R^2 &= 0.9606 \\
 &\text{for } 5 \leq x \leq 100
 \end{aligned}$$

where

x is the distance in meters

and beam width, length are in millimeters

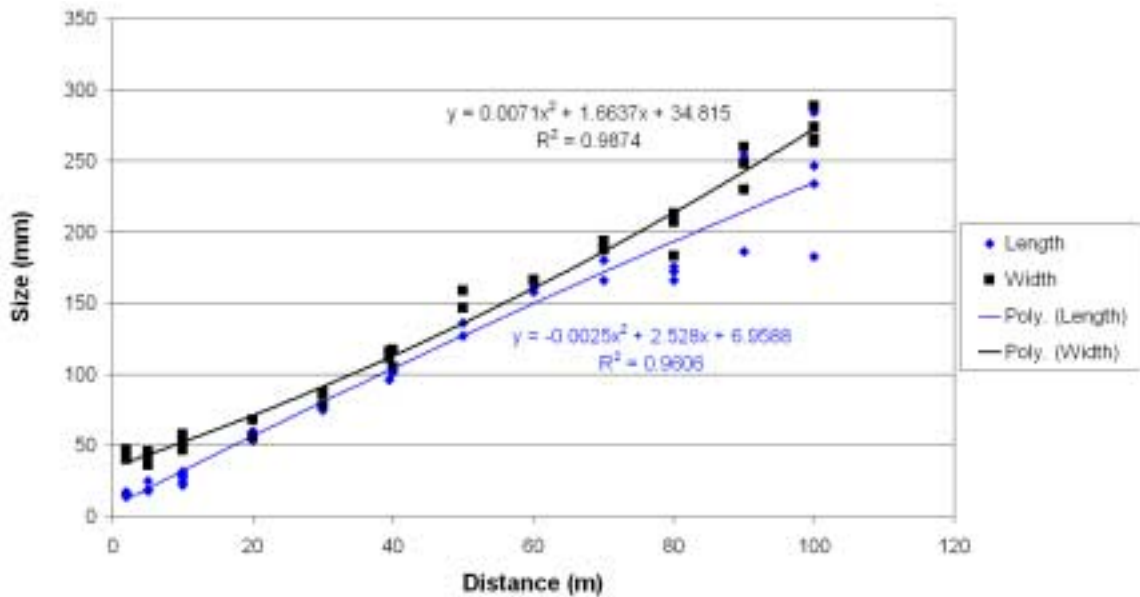

Figure 3.21. Data Set 6: Regression Fits for Laser Beam Length and Width.

Based on the measured beam dimensions, divergences of the beam in the width (horizontal) and length (vertical) directions were calculated. Since there were no measurements of the beam size as it exits the instrument, the beam size at 2 m was taken as the reference or initial beam size for calculating the divergence. The divergence was calculated using the formulas ($\tan \gamma \approx \gamma$ for $\gamma \ll 1$):

$$\gamma_{vertical}(x) = \left(\frac{L(x) - L(2)}{(D(x) - D(2)) * 1000} \right) * 1000 = \left(\frac{L(x) - 15.55}{(D(x) - 2) * 1000} \right) * 1000$$

$$\gamma_{horizontal}(x) = \left(\frac{W(x) - W(2)}{(D(x) - D(2)) * 1000} \right) * 1000 = \left(\frac{W(x) - 43}{(D(x) - 2) * 1000} \right) * 1000$$

where

$\gamma_{vertical}(x), \gamma_{horizontal}(x)$ = divergence at distance x in milliradians

$L(x)$ = Average length, in millimeters, of beam at distance x

$W(x)$ = Average width, in millimeters, of beam at distance x

$D(x)$ = Distance in meters

The beam divergences as a function of distance are shown in Fig. 3.22.

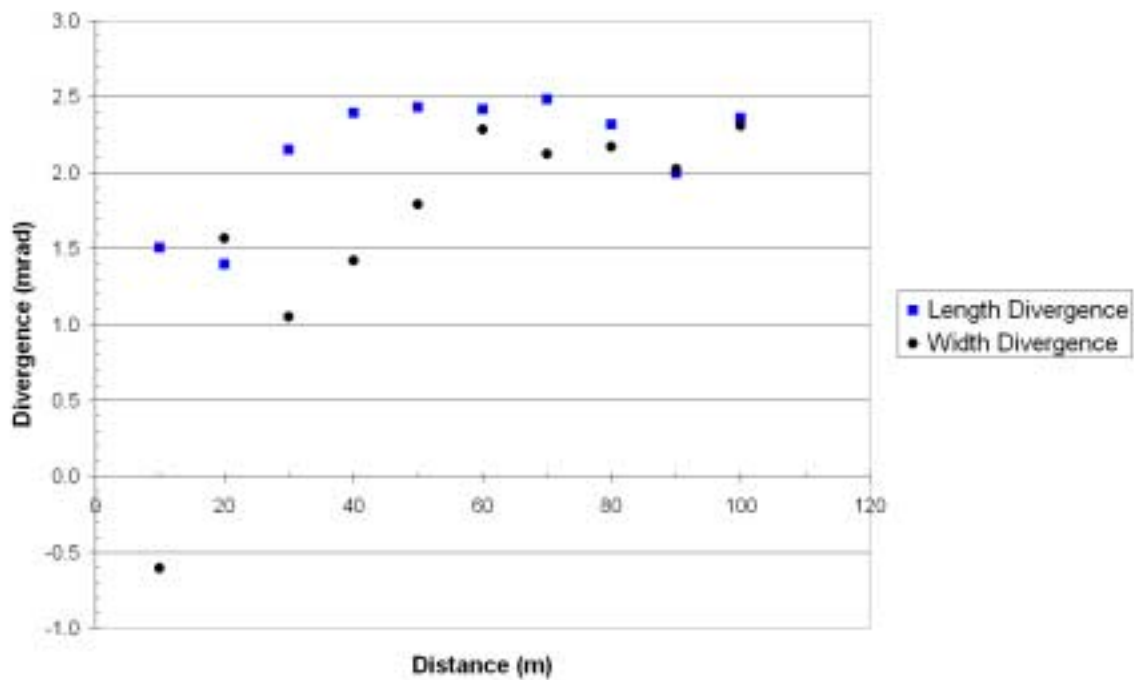

Figure 3.22. Beam Divergence.

The average vertical beam divergence is 2.14 mrad ($\sigma = 0.39$ mrad) and the average horizontal beam divergence, excluding the outlier (negative divergence) is 1.86 mrad ($\sigma = 0.44$ mrad). The average beam divergence, average of horizontal and vertical divergences, is 2.01 mrad ($\sigma = 0.43$ mrad) – compared with the manufacturer’s specified divergence of 3 mrad. The lower experimental value could be a result of the inability of the unaided human eye to detect the faint edges of the laser beam projection.

Plots of the bandwidths of the bright and dark bands are shown in Figs. 3.23 and 3.24. In Fig. 3.23, the bandwidths for the each individual band are plotted and trends are clearly visible for both the bright and dark bands. Linear regression parameters for individual bandwidths are given in Table 3.7.

Table 3.7. Coefficients for Linear Regression for Individual Bandwidths.

Description	Bandwidth [†] (mm)	Slope (M) [†]	Intercept (B) [†]	R ² ‡
Bright Bands				
Left	a [§]	0.1123	11.198	0.2283
Middle	c [§]	0.1842	9.8815	0.2938
Right	e [§]	0.1315	10.643	0.2864
Dark Bands				
Left	b [§]	1.1426	-13.251	0.8954
Right	d [§]	0.9815	-6.0425	0.8702

Notes:
[†] Bandwidth = $Mx + B$ where x = distance in meters; $5 < x < 100$
[‡] Correlation coefficient squared
[§] Corresponds to bands shown in Notes section of Table 3.6.

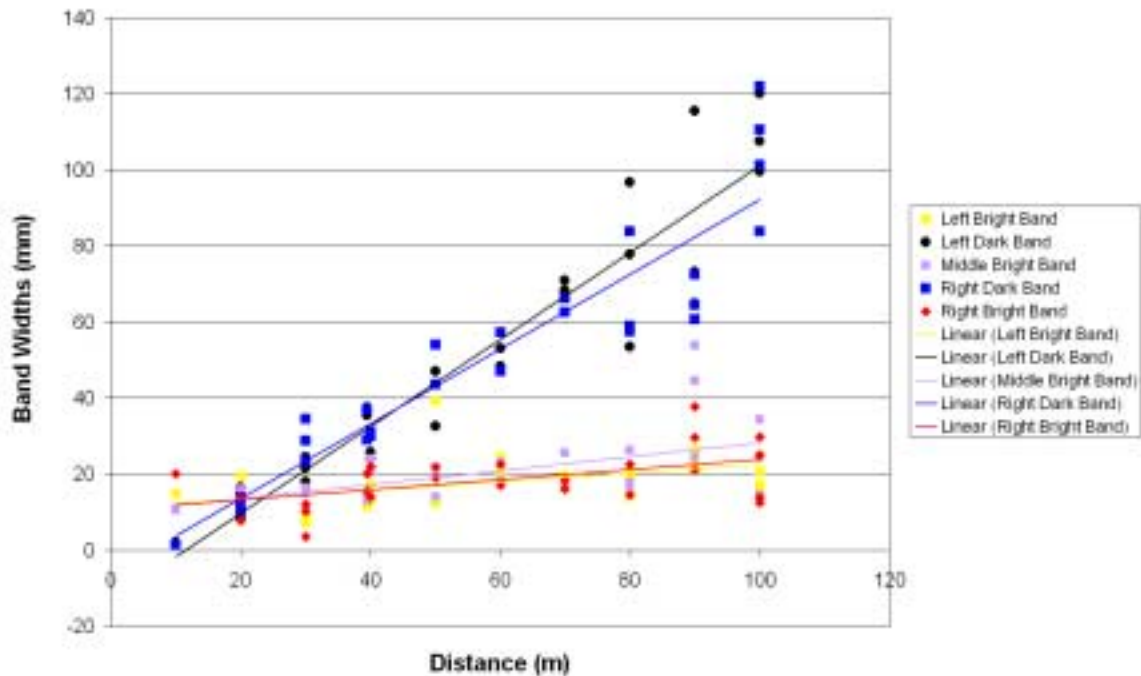

Figure 3.23. Individual Band Widths vs Distance.

Fig. 3.24 is a plot of the same data as shown in Fig. 3.23. With the data for the three bright bands combined and plotted as 'bright band' and the data for the two dark bands combined and plotted as 'dark band'. The regression parameters for the bright and dark bandwidth fits are:

$$\text{Dark bandwidth} = 1.062x - 9.6468 \quad R^2 = 0.8784$$

$$\text{Bright bandwidth} = 0.143x + 10.574 \quad R^2 = 0.2578$$

where

x = distance in meters; $10 < x < 100$

bandwidth in millimeters

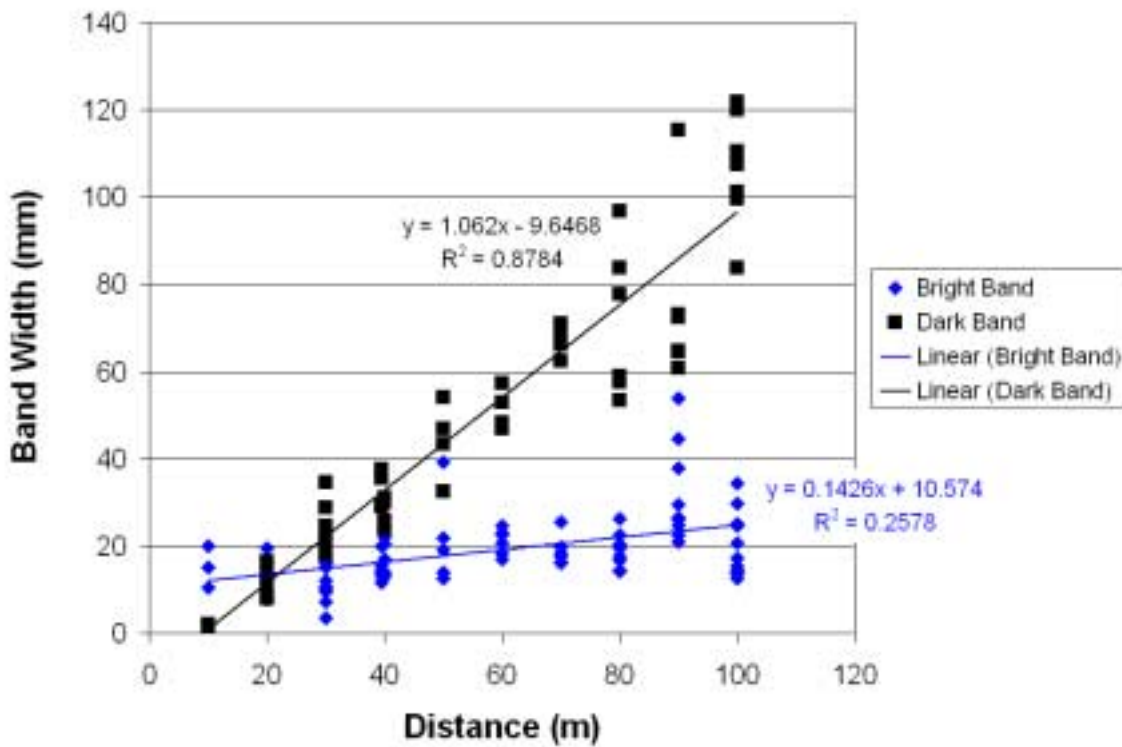

Figure 3.24. Combined Bright and Dark Band Widths vs. Distance.

Judging by the coefficients of determination for the two fits, the bright band shows a poorer fit than the dark band.

3.5 Correlation

The data obtained directly by the instrument are in the form of azimuth angle (θ), elevation angle (φ), distance (R). However, the only measured value is R with the azimuth and elevation angles being obtained from line encoders. Therefore, when polar coordinates are converted to Cartesian

coordinates by the instrument, nominal values (encoder values) of the azimuth and elevation angles are used. Thus, it is not possible to meaningfully evaluate cross-correlations [$\text{corr}(R, \theta)$, $\text{corr}(R, \varphi)$] and only the spatial correlation, $\text{corr}(R, R)$, can be investigated (Section 3.5.2).

3.5.1 Temporal Autocorrelation – Data Set 8

Assuming the 100 pseudo-replicated[§] points taken at one location on the target represent a norm for replication through time for a measurement of the same (geographic) location under fixed operating conditions, it is possible to assess the (temporal) autocorrelation of the instrument by lagging each location's block of 100 points with respect to itself and computing the resulting autocorrelation function (ACF).

$$r_k = \frac{\sum_{t=1}^{N-k} (x_t - \bar{x})(x_{t+k} - \bar{x})}{\sum_{t=1}^N (x_t - \bar{x})^2}$$

Doing this repeatedly across multiple blocks yields plots of the form in Fig. 3.26. In Fig. 3.26, in each frame, the X-axis represents LAG between the two versions of the same time sequence (LAG units coincide with the basic time sampling units) and the Y-axis represents the computed autocorrelation at the lag, i.e., r_k . The two sets of horizontal lines in each plot represents estimated 95 % (2σ) and 99 % (3σ) confidence bands for the autocorrelations. Plot plots outside the ranges of the indicated bounds would represent statistically significant nonzero autocorrelation(s) at 5 % and 1 % significance, respectively.

[§] True replication would involve zeroing out, re-setting, and re-measuring after a substantial time interval.

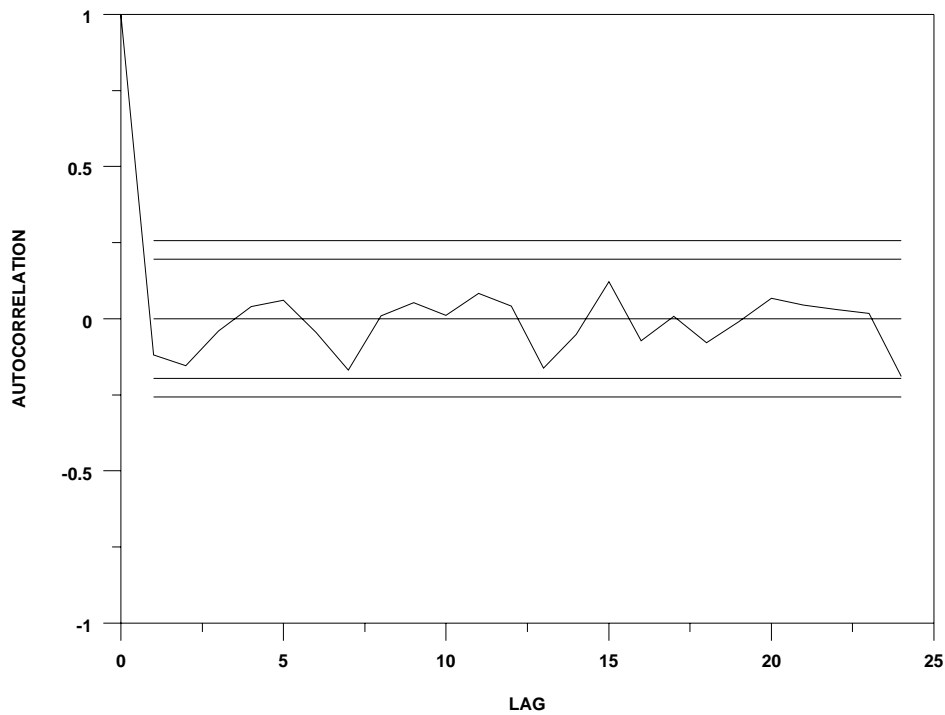

Figure 3.26. Autocorrelation Plots.

The plots in Fig. 3.26 display no significant autocorrelation at nontrivial ($\neq 1$) lags. Significant low-order autocorrelation (lags 2, 3, 4) would be indicative of a stickiness in the replicated points: a tendency for their deviations about their mean to repeat/duplicate themselves at points close in time. Significant high-order autocorrelative structure would be indicative of a quasi-periodicity in the time sequence: a tendency for the sequence to duplicate, or to almost duplicate, itself at some fixed lag.

Autocorrelation causes a bias in the low, or optimistic, direction in variance estimates based on the replicated data. In fact, it is intuitive that the estimates will be biased low because of the tendency of autocorrelated points to self-adhere. Put in simplest terms, autocorrelation induces error in variance (and associated standard deviation) estimates. While the problem is correctable if suspected and detected**, it is obviously preferable that the problem not occur at all. That this is the case here is reassuring.

** An unbiased estimate of the variance can be obtained as the ordinate at zero frequency of the power spectrum

3.5.2 Spatial Autocorrelation – Data Set 7

Data Set 7 is organized as 10 replicates per location at 25 vertically arranged locations along a vertical strip for 3 strips. The presence of the sequence of 10 repetitions at multiple contiguous/adjacent locations enables us to estimate spatial autocorrelation between adjacent, or closely spaced locations along the strip. The key variable in this experiment is the vertical distance between the points. The specified incremental angles between points are 0.045°, 0.090°, and 0.180° which translates to distances of 7.9 mm, 15.7 mm, and 31.4 mm for a target located 10 m from the scanner.

The correlations (lag = 1) for strips 1, 2 and 3 and vertical incremental angles of 0.045°, 0.090°, and 0.180° are given in Tables 3.8, 3.9, and 3.10, respectively.

Table 3.8. Data Set 7: Spatial Correlation For 0.045° Incremental Angle.

Strip 1		Strip 2		Strip 3	
R-R	Std. Error ^{††}	R-R	Std. Error ^{††}	R-R	Std. Error ^{††}
-0.55204	0.25297	0.74432	0.19857	-0.04289	0.34049
0.07578	0.38314	-0.17656	0.36967	-0.03537	0.42698
0.05171	0.39157	0.13766	0.43325	0.19172	0.21671
0.27004	0.40448	-0.28101	0.42454	-0.44123	0.26475
-0.58448	0.1824	-0.57393	0.34741	-0.4847	0.29094
-0.37383	0.23536	0.35231	0.20785	-0.45583	0.23539
0.62769	0.20726	0.52773	0.15336	-0.19037	0.33801
0.50778	0.29949	-0.14254	0.34996	-0.01197	0.30406
-0.26985	0.40095	-0.46646	0.32139	0.01148	0.38466
-0.13945	0.2607	-0.16489	0.35893	-0.42333	0.31418
0.87244	0.09083	-0.77195	0.17778	0.43474	0.2817
0.08739	0.32706	0.26443	0.35237	0.36859	0.26577
-0.57979	0.21134	-0.14849	0.33198	-0.2936	0.28408
0.91375	0.02805	0.78714	0.20364	-0.32593	0.27716
0.09417	0.30343	1.00000	0.00006	0.53441	0.19458
0.82015	0.13774	1.00000	0.00004	0.1823	0.46205
-0.19088	0.32665	-0.31894	0.26856	-0.45655	0.23226
-0.38197	0.20382	0.39947	0.21379	-0.54255	0.25972
0.11923	0.34496	0.24458	0.36047	0.39676	0.29478
-0.35167	0.27788	-0.5899	0.30531	-0.10517	0.26977
-0.43707	0.23681	-0.43439	0.35767	-0.06267	0.30774
0.82979	0.11297	0.04884	0.28561	-0.09866	0.32113
-0.26641	0.37783	-0.12623	0.27751	-0.28201	0.23208
-0.33663	0.32035	0.35376	0.27308	-0.0389	0.4825

Notes: Shaded cells are instances of significant correlation.

^{††} Standard errors for the correlations were estimated by bootstrapping [Efron and Tibshirani, 1993].

Table 3.9. Data Set 7: Spatial Correlation for 0.090° Incremental Angle.

Strip 1		Strip 2		Strip 3	
R-R	Std. Error	R-R	Std. Error	R-R	Std. Error
0.04023	0.31993	-0.37415	0.20074	-0.3325	0.33687
-0.05737	0.38259	0.04083	0.32854	0.27579	0.41989
-0.44075	0.28008	-0.40951	0.31755	0.6197	0.18361
-0.00014	0.32705	0.06147	0.36001	0.15189	0.29353
0.77054	0.10097	0.04636	0.44261	0.50289	0.31596
-0.22626	0.25344	-0.37949	0.30592	0.66239	0.21289
-0.43177	0.27858	-0.11252	0.33779	-0.14162	0.29372
0.32753	0.30081	0.10783	0.39081	0.60301	0.28728
0.62817	0.15617	0.44215	0.17788	0.58331	0.31369
0.45546	0.33414	-0.14143	0.35644	0.38173	0.2345
0.09507	0.36422	-0.58178	0.19458	0.48458	0.39203
-0.01288	0.42003	0.1496	0.33689	-0.15646	0.28488
-0.23579	0.3064	-0.09338	0.37834	-0.22841	0.26505
-0.57032	0.22791	0.01072	0.3388	-0.73704	0.46548
-0.28361	0.37853	-0.2714	0.31101	-0.31044	0.26085
-0.07629	0.36469	-0.07577	0.31151	0.35164	0.26769
-0.01351	0.23284	0.0863	0.3234	0.33585	0.27064
0.2583	0.34492	0.62126	0.23531	0.59442	0.15488
-0.56313	0.25592	-0.28707	0.40308	-0.25577	0.27133
0.42167	0.35682	-0.37826	0.20698	-0.06747	0.29893
-0.75035	0.14136	-0.75785	0.1334	0.21958	0.32173
-0.16274	0.23618	-0.34097	0.34117	-0.36802	0.33458
0.06879	0.24266	-0.09119	0.34036	0.13394	0.38527
0.04338	0.29401	0.62354	0.29509	-0.00936	0.44477

Notes: Shaded cells are instances of significant correlation.

Table 3.10. Data Set 7: Spatial Correlation for 0.180° Incremental Angle.

Strip 1		Strip 2		Strip 3	
R-R	Std. Error	R-R	Std. Error	R-R	Std. Error
-0.02523	0.39223	0.3342	0.34421	0.44386	0.33459
-0.23081	0.37593	-0.45636	0.35246	0.02245	0.40943
0.03178	0.36891	0.45053	0.2358	0.00256	0.3951
0.19884	0.23042	0.26613	0.42503	-0.30439	0.36607
0.04748	0.36262	0.42192	0.26559	-0.18638	0.34745
-0.29251	0.261	0.33306	0.27872	-0.1293	0.32023
-0.74941	0.27052	-0.36537	0.2864	-0.11169	0.35782
0.18529	0.40528	-0.33562	0.29819	0.67417	0.14484

Strip 1		Strip 2		Strip 3	
R-R	Std. Error	R-R	Std. Error	R-R	Std. Error
0.42923	0.4175	0.14002	0.42949	-0.34621	0.30111
-0.58264	0.14779	0.32185	0.40692	-0.17787	0.36141
0.21543	0.33636	0.16281	0.35796	0.47939	0.24581
-0.55006	0.35867	-0.19229	0.38524	0.47337	0.2233
-0.10123	0.31639	-0.5181	0.23856	0.44582	0.36826
-0.01678	0.33585	0.17932	0.35488	-0.40009	0.35683
-0.60713	0.20003	-0.0475	0.39304	0.54936	0.26534
0.01777	0.38883	0.32296	0.31779	0.02965	0.32261
0.24499	0.29048	0.03808	0.2709	-0.31793	0.25856
-0.10405	0.2983	-0.18809	0.26094	0.2797	0.31558
-0.1687	0.47751	0.37456	0.18533	0.02767	0.29249
-0.57767	0.31923	0.03594	0.31149	-0.53119	0.2245
-0.2125	0.35412	-0.02728	0.38385	0.50402	0.28571
-0.15705	0.30546	-0.49235	0.25695	-0.20329	0.3737
0.39246	0.41459	0.8526	0.07813	-0.08847	0.27742
-0.40737	0.46504	0.12131	0.41772	0.21695	0.23713

Notes: Shaded cells are instances of significant correlation.

Examination of the correlation values and associated standard errors^{‡‡} shows that there is sporadic, seemingly, random statistically significant correlation between contiguous measurements in a vertical strip. The number of incidences of significant spatial correlation (shaded cells in Tables 3.8 to 3.10) increases as the incremental angle decreases, i.e., the vertical distance between points decreases. Since the findings in this experiment are inconclusive, the existence of spatial autocorrelation will require further investigation. If spatial autocorrelation is present, simple propagation of error methods, that is, propagation of error that does not take 2nd order, cross-correlation terms into account, may not yield reliable results.

^{‡‡} Double the standard errors and check to see if the interval correlation $\pm (2 \sigma)$ crosses zero. If it does, the correlation is statistically indistinguishable from zero at 95 % confidence.

4.0 CONCLUSIONS AND RESEARCH NEEDS

4.1 Summary and Conclusions

The potential applications of LADARs are numerous and they cross over several sectors of industry – construction, large-scale manufacturing, remote sensing, national defense (military). As the use of LADARs increases, there is a growing need to characterize the LADARs and to develop statistically justifiable uncertainties for the LADAR data and their end products. There have been only a handful of such efforts in this area.

To evaluate surface generation algorithms objectively, the accuracy/precision characteristics of the sensor must first be determined. Therefore, in the first phase of a NIST project, calibration experiments, varying distance/size/color/reflectivity of targets were conducted. In the second phase, evaluations of surface generation algorithms with respect to meshing, registration, data editing (filtering, handling outliers, etc.) were performed and are reported in Witzgall and Cheok [2001] and in a second report that is in preparation. In the third phase, all such knowledge has to be integrated into a credible calculation of statistical uncertainty for reconstructed scenes and derived values such as volume.

As part of the first phase, a series of exploratory experiments to characterize a laser scanner was conducted and these efforts are chronicled in this report. These experiments served three purposes: 1) assessment of the accuracy and precision of the range measurements, 2) learning process for the use of and familiarization with a LADAR, and 3) to address specific needs as they arose. The experimental parameters examined included target color, texture, reflectivity, angle of incidence, and beam divergence. The effects of target reflectivity and distance on the intensity value were examined to assess the possibility of using intensity values to identify objects within a scene.

The initial findings can be summarized as follows:

1. *Accuracy:*
 - a. For the instrument calibrated, for the two extreme colors (black and white) and for angle of incidences equal to 0° , the measurement errors (Data Set 5) generally fell within the ± 5 cm bounds (manufacturer's upper bounds).
 - b. Reduction of the laser output power (filter on laser) significantly decreased accuracy of a less reflective target (black) at the upper range of the LADAR.
2. *Color Effect (Reflectivity):*
 - a. Comparisons of the global regression line statistics show no dramatic color effect.
 - b. Less reflective targets (black, dark gray) are less precise at longer distances than more reflective targets (white).
 - c. Biases are also observed for some of the colors: a pink target is biased low. Dark gray and black targets are biased high.
 - d. Reduction of the laser output power (filter on laser) significantly decreased precision at the upper range of the LADAR regardless of target color.

3. *Angle of incidence:*
 - a. As expected, the angle of incidence affects the range accuracy. Highly reflective targets (silver, shiny) yield the largest measurement errors for this series of experiments and are the least precise – for angles of incidence of 50° and greater.
 - b. The least reflective target (black) sustains the most misses (no returns) as the angle of incidence increases.
4. *LDP material (Highly reflective):*
 - a. Consistently high (>200) intensities for the entire range of the scanner was observed which makes the LDP material a potential candidate for the fabrication of bar codes.
 - b. Very significant measurement errors are observed for this material for distances less than 40 m due to saturation of the detector.
5. *Autocorrelation:*
 - a. No evidence of significant temporal autocorrelation was observed.
 - b. Random significant spatial correlations between contiguous measurements were observed and require further investigation.

These findings are based on a very limited number of experiments and on one type of laser scanner. It should be kept in mind that these findings are likely instrument dependent. Further experiments are needed to verify fully and expand upon these findings and to refine the calibration procedure.

The initial efforts and findings presented in this report provide a better understanding of what is required to calibrate similar sensors in terms of significant parameters affecting range measurements, test procedures, and calibration facility requirements. Additional experiments with other types of laser scanners would be necessary to develop standard calibration protocols appropriate for all or most of the commercially available scanners.

4.2 Research Needs

There are currently no facilities or standard test protocols for the calibration or performance evaluation of LADARs [Marshall et al. 2001]. As the potential application of LADARs grows, there is a need to establish a facility to calibrate and evaluate these types of sensors. It is anticipated that such a calibration facility would consist of an indoor and an outdoor facility. The indoor facility would allow for calibrations to be conducted in a controlled environment (temperature, humidity, pressure) while an outdoor facility would permit the evaluation of the scanner performance in a more realistic environment.

Test protocols and calibrations for the indoor facility would fall under two general categories:

- hardware calibration
 - distance accuracy and precision
 - pointing accuracy and precision
 - laser beam divergence

- depth and horizontal resolution – what is the minimum distance between objects that is detectable by the sensor
- minimum object size that is detectable by the sensor
- stability/degradation of sensor over time
- performance evaluation using artifacts – i.e., given several standard artifacts, how accurately and precisely can the following characteristics be determined:
 - dimensions
 - position/location
 - area/volume
 - geometry/object identity

In the second category, performance evaluation involves the assessment of the combination of hardware and software to produce a desired end product. LADAR data could be used “as is” (point cloud), but the full potential of such data lies in the use of the data to create 3D models from which positions, dimensions, areas, volumes, etc. can be ascertained. This process involves software to register multiple scans and to mesh the point cloud, as well as methods to clean/filter and to subsample the data. In general, the calibrations obtained from the first category above could be used for propagating instrument error through to the end product and to determine how to improve the scanner, whereas the calibrations in the second category would be used to measure and explicitly note the performance of the scanner. Metrics to evaluate the scanner performance are harder to establish than the metrics to evaluate the hardware accuracy and precision.

For each of the subtopics listed for hardware calibrations and performance evaluation, many issues have to be resolved. These issues include determining the optical characteristics of the standard targets (color, reflectivity, texture, etc.), shape, size, material, and placement of the artifacts, and choice of software package. Some hardware specific issues include developing methods to ensure that the target is perpendicular to the laser and procedures for dealing with instruments that are not setup for single point acquisition.

The outdoor facility would consist of designated areas that are open, partially wooded, and wooded. Permanent benchmarks would be located throughout the designated areas for accurately locating the sensor. In addition to allowing for the evaluation of the scanner under more realistic conditions, the outdoor facility would also allow for the evaluation of the sensor’s ability to map terrain in different seasons – full foliage (summer), partial foliage (spring and fall), and no foliage (winter), and in different environmental conditions – sunny, cloudy, dusty, hot, cold. Artifacts could also be used in the outdoor facility.

The successful establishment of a LADAR calibration and the development of test protocols would require the participation, cooperation, and acceptance by the LADAR manufacturers and end users. This collaborative effort should start at the initial planning phases and continue throughout the whole process. The standardization of the test protocols would also require the inclusion of standards writing organizations such as American National Standards Institute (ANSI) and the American Society of Non-Destructive Testing.

REFERENCES

- Collier, R. [1998]**, “Characterization of a Range Scanning System Utilizing a Point Laser Rangefinder,” MS Thesis, University of Tennessee, Knoxville, August, 74 pp.
- Efron, B. and Tibshirani, R. J. [1993]**, *An Introduction to the Bootstrap*, Chapman and Hall, New York.
- El-Hakim, S. F., Beraldin, J. A., and Blais, F. [1995]**, “A Comparative Evaluation of the Performance of Passive and Active 3-D Vision Systems,” *Proc. St. Petersburg Conference on Digital Photogrammetry*, St. Petersburg, Russia, June 25-30, 1995. NRC 39160.
- Kweon, I. S., Hoffman, R. and Krotkov [1991]**, “Experimental Characterization of the Perceptron Laser Rangefinder,” CMU-RI-TR-91-1, The Robotics Institute, Carnegie Mellon University, Pittsburgh, PA, January, 44 pp.
- Marshall, S. J., and Gilby, J. H. [2001]**, “New Opportunities in Non-Contact 3D Measurement,” *Proc. National Measurement Conf.*, 2001, Harrogate, UK.
- Marshall, S. J., Whiteford, D. N., and Rixon, R. C. [2001]**, “Assessing the Performance of 3D Whole Body Imaging Systems,” *Proc. 6th Numérisation 3D/Scanning 2001 Congress*, Paris, France.
- Sachs, L. (1982)**, *Applied Statistics: A Handbook of Techniques*, New York, Springer-Verlag, p. 442.
- Taylor, J. R. [1997]**, *An Introduction to Error Analysis: The Study of Uncertainties in Physical Measurements*, 2nd ed., University Science Books, Sausalito, CA.
- Witzgall, C. and Cheok, G. S. [2001]**, “Registering 3D Point Clouds: An Experimental Evaluation,” *NISTIR 6743*, National Institute of Standards and Technology, Gaithersburg, MD, May, 41 pp.

APPENDIX A – Relative Distance

Table A.1 Data Set 1 - Relative Distance Calibration: 0 m to 60 m

Location: Environmentally controlled lab, Bldg. 220		File: rel_dist_anal.xls			
No Filter					
Test Dates: July 14-15, 1999					
Interfero. Dist. (mm) tall post	Wht., not shiny (m)	Interfero. Dist. (mm) short post	Wht.,not shiny (m)	Interfero. Dist. (mm) tall post	Wht., shiny (m)
0.00	4.315	0.00	4.468	0.00	4.588
0.00	4.335	0.00	4.508	0.00	4.608
0.00	4.395	0.00	4.468	0.00	4.608
0.00	4.315	0.00	4.488	0.00	4.548
0.00	4.315	0.00	4.488	0.00	4.608
0.00	4.235	0.00	4.448	0.00	4.628
0.00	4.295	0.00	4.448	0.00	4.588
0.00	4.375	0.00	4.408	0.00	4.608
0.00	4.415	0.00	4.408	0.00	4.608
0.00	4.375	0.00	4.488	0.00	4.608
0.00	4.370	0.00	4.488	0.00	4.568
0.00	4.430	0.00	4.448	0.00	4.608
0.00	4.410	0.00	4.488	0.00	4.608
0.00	4.390	0.00	4.428	0.00	4.628
0.00	4.450	0.00	4.408	0.00	4.588
0.00	4.310	0.00	4.488	0.00	4.588
0.00	4.370	0.00	4.548	0.00	4.628
0.00	4.410	0.00	4.548	0.00	4.588
0.00	4.410	0.00	4.408	0.00	4.548
0.00	4.390	0.00	4.468	0.00	4.628
0.00	4.370	0.00	4.508	0.00	4.568
0.00	4.330	0.00	4.468	0.00	4.608
0.00	4.370	0.00	4.488	0.00	4.608
0.00	4.390	0.00	4.428	0.00	4.588
0.00	4.430	0.00	4.428	0.00	4.608
2047.17	6.312	2001.82	6.510	2000.02	6.630
2047.17	6.427	2001.82	6.510	2000.02	6.59
2047.17	6.347	2001.82	6.330	2000.02	6.63
2047.17	6.407	2001.82	6.490	2000.02	6.59
2047.17	6.407	2001.82	6.450	2000.02	6.57
2047.17	6.367	2001.82	6.450	2000.02	6.61
2047.17	6.367	2001.82	6.390	2000.02	6.63
2047.17	6.387	2001.82	6.410	2000.02	6.61
2047.17	6.507	2001.82	6.550	2000.02	6.61
2047.17	6.387	2001.82	6.430	2000.02	6.55
2047.17	6.387	2001.82	6.450	2000.02	6.57
2047.17	6.407	2001.82	6.450	2000.02	6.61
2047.17	6.503	2001.82	6.410	2000.02	6.59
2047.17	6.307	2001.82	6.570	2000.02	6.63
2047.17	6.447	2001.82	6.530	2000.02	6.59
2047.17	6.427	2001.82	6.470	2000.02	6.63
2047.17	6.263	2001.82	6.490	2000.02	6.61
2047.17	6.463	2001.82	6.410	2000.02	6.59
2047.17	6.423	2001.82	6.550	2000.02	6.65
2047.17	6.403	2001.82	6.490	2000.02	6.63
2047.17	6.363	2001.82	6.570	2000.02	6.63
2047.17	6.363	2001.82	6.470	2000.02	6.63
2047.17	6.483	2001.82	6.510	2000.02	6.63
2047.17	6.383	2001.82	6.410	2000.02	6.63
2047.17	6.423	2001.82	6.550	2000.02	6.63
2047.17	6.423	4000.22	8.573	4000.21	8.593
4005.47	8.266	4000.22	8.453	4000.21	8.573
4005.47	8.226	4000.22	8.453	4000.21	8.593
4005.47	8.266	4000.22	8.453	4000.21	8.573
4005.47	8.246	4000.22	8.373	4000.21	8.593

Table A.1 Data Set 1 - Relative Distance Calibration: 0 m to 60 m

Location: Environmentally controlled lab, Bldg. 220				File: rel_dist_anal.xls	
No Filter					
Test Dates: July 14-15, 1999					
Interfero. Dist. (mm) tall post	Wht., not shiny (m)	Interfero. Dist. (mm) short post	Wht.,not shiny (m)	Interfero. Dist. (mm) tall post	Wht., shiny (m)
4005.47	8.346	4000.22	8.493	4000.21	8.593
4005.47	8.326	4000.22	8.453	4000.21	8.633
4005.47	8.281	4000.22	8.493	4000.21	8.613
4005.47	8.301	4000.22	8.633	4000.21	8.593
4005.47	8.341	4000.22	8.593	4000.21	8.653
4005.47	8.401	4000.22	8.493	4000.21	8.593
4005.47	8.341	4000.22	8.433	4000.21	8.613
4005.47	8.301	4000.22	8.493	4000.21	8.613
4005.47	8.321	4000.22	8.433	4000.21	8.573
4005.47	8.381	4000.22	8.493	4000.21	8.553
4005.47	8.261	4000.22	8.453	4000.21	8.593
4005.47	8.341	4000.22	8.453	4000.21	8.593
4005.47	8.381	4000.22	8.473	4000.21	8.593
4005.47	8.341	4000.22	8.493	4000.21	8.593
4005.47	8.341	4000.22	8.353	4000.21	8.613
4005.47	8.341	4000.22	8.373	4000.21	8.613
4005.47	8.221	4000.22	8.573	4000.21	8.533
4005.47	8.361	4000.22	8.533	4000.21	8.553
4005.47	8.321	4000.22	8.613	4000.21	8.613
4005.47	8.321	4000.22	8.493	4000.21	8.653
4005.47	8.301	6002.26	10.496	6000.07	10.616
4005.47	8.421	6002.26	10.536	6000.07	10.576
6005.04	10.304	6002.26	10.636	6000.07	10.616
6005.04	10.284	6002.26	10.636	6000.07	10.596
6005.04	10.424	6002.26	10.536	6000.07	10.616
6005.04	10.224	6002.26	10.676	6000.07	10.616
6005.04	10.264	6002.26	10.596	6000.07	10.576
6005.04	10.324	6002.26	10.556	6000.07	10.576
6005.04	10.304	6002.26	10.616	6000.07	10.616
6005.04	10.324	6002.26	10.436	6000.07	10.636
6005.04	10.364	6002.26	10.536	6000.07	10.596
6005.04	10.304	6002.26	10.476	6000.07	10.576
6005.04	10.384	6002.26	10.456	6000.07	10.596
6005.04	10.284	6002.26	10.456	6000.07	10.576
6005.04	10.279	6002.26	10.476	6000.07	10.616
6005.04	10.324	6002.26	10.476	6000.07	10.636
6005.04	10.359	6002.26	10.556	6000.07	10.576
6005.04	10.379	6002.26	10.476	6000.07	10.616
6005.04	10.299	6002.26	10.436	6000.07	10.616
6005.04	10.359	6002.26	10.596	6000.07	10.536
6005.04	10.359	6002.26	10.536	6000.07	10.616
6005.04	10.404	6002.26	10.516	6000.07	10.636
6005.04	10.359	6002.26	10.496	6000.07	10.616
6005.04	10.399	6002.26	10.576	6000.07	10.616
6005.04	10.319	6002.26	10.456	6000.07	10.596
6005.04	10.239	8001.15	12.580	8001.04	12.620
6005.04	10.319	8001.15	12.459	8001.04	12.6
8009.23	12.402	8001.15	12.479	8001.04	12.56
8009.23	12.402	8001.15	12.439	8001.04	12.58
8009.23	12.382	8001.15	12.500	8001.04	12.58
8009.23	12.282	8001.15	12.439	8001.04	12.58
8009.23	12.322	8001.15	12.580	8001.04	12.58
8009.23	12.362	8001.15	12.620	8001.04	12.58
8009.23	12.402	8001.15	12.540	8001.04	12.58
8009.23	12.262	8001.15	12.479	8001.04	12.58
8009.23	12.302	8001.15	12.559	8001.04	12.6
8009.23	12.302	8001.15	12.500	8001.04	12.54
8009.23	12.422	8001.15	12.479	8001.04	12.58
8009.23	12.282	8001.15	12.540	8001.04	12.6
8009.23	12.282	8001.15	12.520	8001.04	12.6

Table A.1 Data Set 1 - Relative Distance Calibration: 0 m to 60 m

Location: Environmentally controlled lab, Bldg. 220				File: rel_dist_anal.xls	
No Filter					
Test Dates: July 14-15, 1999					
Interfero. Dist. (mm) tall post	Wht., not shiny (m)	Interfero. Dist. (mm) short post	Wht.,not shiny (m)	Interfero. Dist. (mm) tall post	Wht., shiny (m)
8009.23	12.262	8001.15	12.540	8001.04	12.56
8009.23	12.322	8001.15	12.500	8001.04	12.58
8009.23	12.342	8001.15	12.540	8001.04	12.6
8009.23	12.362	8001.15	12.479	8001.04	12.6
8009.23	12.362	8001.15	12.540	8001.04	12.58
8009.23	12.322	8001.15	12.540	8001.04	12.6
8009.23	12.342	8001.15	12.439	8001.04	12.58
8009.23	12.362	8001.15	12.620	8001.04	12.58
8009.23	12.422	8001.15	12.560	8001.04	12.6
8009.23	12.402	8001.15	12.379	8001.04	12.62
8009.23	12.302	10000.28	14.584	10000.81	14.564
8009.23	12.402	10000.28	14.524	10000.81	14.604
10021.08	14.346	10000.28	14.483	10000.81	14.564
10021.08	14.452	10000.28	14.584	10000.81	14.604
10021.08	14.312	10000.28	14.584	10000.81	14.544
10021.08	14.392	10000.28	14.564	10000.81	14.604
10021.08	14.392	10000.28	14.504	10000.81	14.604
10021.08	14.337	10000.28	14.564	10000.81	14.564
10021.08	14.352	10000.28	14.504	10000.81	14.584
10021.08	14.392	10000.28	14.483	10000.81	14.584
10021.08	14.417	10000.28	14.524	10000.81	14.564
10021.08	14.332	10000.28	14.584	10000.81	14.604
10021.08	14.352	10000.28	14.544	10000.81	14.584
10021.08	14.252	10000.28	14.483	10000.81	14.564
10021.08	14.352	10000.28	14.564	10000.81	14.584
10021.08	14.372	10000.28	14.604	10000.81	14.644
10021.08	14.432	10000.28	14.624	10000.81	14.624
10021.08	14.332	10000.28	14.524	10000.81	14.584
10021.08	14.332	10000.28	14.504	10000.81	14.564
10021.08	14.452	10000.28	14.524	10000.81	14.584
10021.08	14.372	10000.28	14.564	10000.81	14.624
10021.08	14.372	10000.28	14.544	10000.81	14.604
10021.08	14.332	10000.28	14.504	10000.81	14.604
10021.08	14.352	10000.28	14.604	10000.81	14.584
10021.08	14.452	10000.28	14.584	10000.81	14.584
10021.08	14.392	14997.95	19.425	15006.54	19.605
10021.08	14.312	14997.95	19.445	15006.54	19.605
15026.58	19.334	14997.95	19.485	15006.54	19.545
15026.58	19.334	14997.95	19.445	15006.54	19.565
15026.58	19.314	14997.95	19.425	15006.54	19.585
15026.58	19.374	14997.95	19.525	15006.54	19.585
15026.58	19.314	14997.95	19.405	15006.54	19.545
15026.58	19.394	14997.95	19.425	15006.54	19.605
15026.58	19.334	14997.95	19.454	15006.54	19.585
15026.58	19.274	14997.95	19.425	15006.54	19.585
15026.58	19.374	14997.95	19.425	15006.54	19.565
15026.58	19.374	14997.95	19.445	15006.54	19.585
15026.58	19.374	14997.95	19.485	15006.54	19.605
15026.58	19.354	14997.95	19.445	15006.54	19.545
15026.58	19.334	14997.95	19.485	15006.54	19.585
15026.58	19.394	14997.95	19.485	15006.54	19.585
15026.58	19.294	14997.95	19.425	15006.54	19.605
15026.58	19.334	14997.95	19.485	15006.54	19.545
15026.58	19.334	14997.95	19.425	15006.54	19.545
15026.58	19.354	14997.95	19.465	15006.54	19.585
15026.58	19.294	14997.95	19.405	15006.54	19.545
15026.58	19.354	14997.95	19.485	15006.54	19.565
15026.58	19.414	14997.95	19.425	15006.54	19.585
15026.58	19.294	14997.95	19.405	15006.54	19.545
15026.58	19.294	14997.95	19.445	15006.54	19.585

Table A.1 Data Set 1 - Relative Distance Calibration: 0 m to 60 m

Location: Environmentally controlled lab, Bldg. 220				File: rel_dist_anal.xls	
No Filter					
Test Dates: July 14-15, 1999					
Interfero. Dist. (mm) tall post	Wht., not shiny (m)	Interfero. Dist. (mm) short post	Wht.,not shiny (m)	Interfero. Dist. (mm) tall post	Wht., shiny (m)
15026.58	19.394	20010.64	24.425	20136.28	24.725
15026.58	19.274	20010.64	24.505	20136.28	24.745
20015.67	24.274	20010.64	24.505	20136.28	24.685
20015.67	24.31	20010.64	24.565	20136.28	24.725
20015.67	24.27	20010.64	24.505	20136.28	24.705
20015.67	24.29	20010.64	24.485	20136.28	24.685
20015.67	24.25	20010.64	24.555	20136.28	24.725
20015.67	24.35	20010.64	24.485	20136.28	24.725
20015.67	24.29	20010.64	24.445	20136.28	24.765
20015.67	24.31	20010.64	24.445	20136.28	24.725
20015.67	24.33	20010.64	24.405	20136.28	24.725
20015.67	24.31	20010.64	24.445	20136.28	24.705
20015.67	24.33	20010.64	24.525	20136.28	24.705
20015.67	24.29	20010.64	24.445	20136.28	24.705
20015.67	24.31	20010.64	24.425	20136.28	24.685
20015.67	24.33	20010.64	24.465	20136.28	24.705
20015.67	24.27	20010.64	24.505	20136.28	24.765
20015.67	24.31	20010.64	24.525	20136.28	24.665
20015.67	24.31	20010.64	24.485	20136.28	24.685
20015.67	24.27	20010.64	24.545	20136.28	24.685
20015.67	24.33	20010.64	24.505	20136.28	24.705
20015.67	24.29	20010.64	24.485	20136.28	24.685
20015.67	24.33	20010.64	24.485	20136.28	24.705
20015.67	24.37	20010.64	24.565	20136.28	24.725
20015.67	24.31	20010.64	24.545	20136.28	24.725
20015.67	24.29	30007.36	34.445	30806.36	35.385
20015.67	24.25	30007.36	34.505	30806.36	35.325
29936.1	34.250	30007.36	34.465	30806.36	35.365
29936.1	34.23	30007.36	34.545	30806.36	35.365
29936.1	34.23	30007.36	34.465	30806.36	35.365
29936.1	34.21	30007.36	34.545	30806.36	35.385
29936.1	34.21	30007.36	34.465	30806.36	35.325
29936.1	34.23	30007.36	34.465	30806.36	35.465
29936.1	34.19	30007.36	34.485	30806.36	35.365
29936.1	34.23	30007.36	34.505	30806.36	35.345
29936.1	34.21	30007.36	34.465	30806.36	35.385
29936.1	34.27	30007.36	34.505	30806.36	35.325
29936.1	34.19	30007.36	34.485	30806.36	35.425
29936.1	34.17	30007.36	34.485	30806.36	35.365
29936.1	34.23	30007.36	34.525	30806.36	35.385
29936.1	34.21	30007.36	34.505	30806.36	35.385
29936.1	34.21	30007.36	34.485	30806.36	35.385
29936.1	34.23	30007.36	34.465	30806.36	35.345
29936.1	34.21	30007.36	34.485	30806.36	35.385
29936.1	34.19	30007.36	34.465	30806.36	35.365
29936.1	34.23	30007.36	34.505	30806.36	35.385
29936.1	34.27	30007.36	34.385	30806.36	35.385
29936.1	34.19	30007.36	34.325	30806.36	35.385
29936.1	34.23	30007.36	34.505	30806.36	35.385
29936.1	34.23	30007.36	34.485	30806.36	35.365
29936.1	34.23	0.00	4.468	39913.22	44.425
29936.1	34.25	0.00	4.508	39913.22	44.425
39998.52	44.870	0.00	4.528	39913.22	44.445
39998.52	44.89	0.00	4.508	39913.22	44.465
39998.52	44.89	0.00	4.488	39913.22	44.445
39998.52	44.83	0.00	4.548	39913.22	44.465
39998.52	44.87	0.00	4.468	39913.22	44.425
39998.52	44.805	0.00	4.488	39913.22	44.445
39998.52	44.865	0.00	4.468	39913.22	44.465
39998.52	44.85	0.00	4.388	39913.22	44.465

Table A.1 Data Set 1 - Relative Distance Calibration: 0 m to 60 m

Location: Environmentally controlled lab, Bldg. 220		File: rel_dist_anal.xls			
No Filter					
Test Dates: July 14-15, 1999					
Interfero. Dist. (mm) tall post	Wht., not shiny (m)	Interfero. Dist. (mm) short post	Wht.,not shiny (m)	Interfero. Dist. (mm) tall post	Wht., shiny (m)
39998.52	44.87	0.00	4.428	39913.22	44.445
39998.52	44.87	0.00	4.528	39913.22	44.465
39998.52	44.81	0.00	4.488	39913.22	44.425
39998.52	44.83	0.00	4.488	39913.22	44.445
39998.52	44.81	0.00	4.468	39913.22	44.445
39998.52	44.89	0.00	4.448	39913.22	44.465
39998.52	44.85	0.00	4.448	39913.22	44.465
39998.52	44.85	0.00	4.488	39913.22	44.465
39998.52	44.85	0.00	4.488	39913.22	44.465
39998.52	44.91	0.00	4.488	39913.22	44.405
39998.52	44.89	0.00	4.388	39913.22	44.465
39998.52	44.83	0.00	4.548	39913.22	44.465
39998.52	44.85	0.00	4.508	39913.22	44.425
39998.52	44.83	0.00	4.568	39913.22	44.425
39998.52	44.83	0.00	4.528	39913.22	44.445
39998.52	44.87	39995.68	44.465	39913.22	44.445
39998.52	44.85	39995.68	44.545	49895.7	54.465
49954.58	54.505	39995.68	44.465	49895.7	54.485
49954.58	54.525	39995.68	44.505	49895.7	54.485
49954.58	54.565	39995.68	44.485	49895.7	54.445
49954.58	54.605	39995.68	44.465	49895.7	54.465
49954.58	54.485	39995.68	44.465	49895.7	54.445
49954.58	54.605	39995.68	44.505	49895.7	54.465
49954.58	54.565	39995.68	44.525	49895.7	54.485
49954.58	54.525	39995.68	44.465	49895.7	54.465
49954.58	54.465	39995.68	44.425	49895.7	54.445
49954.58	54.505	39995.68	44.505	49895.7	54.445
49954.58	54.565	39995.68	44.445	49895.7	54.445
49954.58	54.585	39995.68	44.485	49895.7	54.465
49954.58	54.525	39995.68	44.505	49895.7	54.465
49954.58	54.545	39995.68	44.525	49895.7	54.445
49954.58	54.545	39995.68	44.585	49895.7	54.445
49954.58	54.545	39995.68	44.505	49895.7	54.465
49954.58	54.505	39995.68	44.585	49895.7	54.465
49954.58	54.565	39995.68	44.505	49895.7	54.445
49954.58	54.525	39995.68	44.565	49895.7	54.445
49954.58	54.465	39995.68	44.505	49895.7	54.445
49954.58	54.565	39995.68	44.565	49895.7	54.445
49954.58	54.545	39995.68	44.585	49895.7	54.465
49954.58	54.625	39995.68	44.565	49895.7	54.465
49954.58	54.545	49951.73	54.365	49895.7	54.485
49954.58	54.505	49951.73	54.405	49895.7	54.465
		49951.73	54.465		
		49951.73	54.445		
		49951.73	54.425		
		49951.73	54.465		
		49951.73	54.425		
		49951.73	54.445		
		49951.73	54.445		
		49951.73	54.385		
		49951.73	54.365		
		49951.73	54.445		
		49951.73	54.405		
		49951.73	54.405		
		49951.73	54.425		
		49951.73	54.465		
		49951.73	54.405		
		49951.73	54.425		
		49951.73	54.425		
		49951.73	54.445		

Table A.1 Data Set 1 - Relative Distance Calibration: 0 m to 60 m

Location: Environmentally controlled lab, Bldg. 220			File: rel_dist_anal.xls		
No Filter					
Test Dates: July 14-15, 1999					
Interfero. Dist. (mm) tall post	Wht., not shiny (m)	Interfero. Dist. (mm) short post	Wht.,not shiny (m)	Interfero. Dist. (mm) tall post	Wht., shiny (m)
		49951.73	54.425		
		49951.73	54.425		
		49951.73	54.465		
		49951.73	54.565		
		49951.73	54.505		

Table A.1 Data Set1 - Relative Distance Calibration: 0 m to 60 m

Location: Environmentally controlled lab, Bldg. 220				File: rel_dist_anal.xls			
No Filter							
Test dates: July 14-15, 1999							
Interfero. Dist. (mm)	Blck, not shiny (m)	Interfero. Dist. (mm)	Blck, shiny (m)	Interfero. Dist. (mm)	Dk. Grey, rough (m)	Interfero. Dist. (mm)	Pink, not shiny (m)
0	4.428	0	4.428	0	4.468	0	4.548
0	4.428	0	4.388	0	4.408	0	4.528
0	4.408	0	4.408	0	4.408	0	4.528
0	4.408	0	4.408	0	4.428	0	4.488
0	4.488	0	4.408	0	4.408	0	4.488
0	4.368	0	4.408	0	4.388	0	4.548
0	4.388	0	4.408	0	4.428	0	4.508
0	4.408	0	4.368	0	4.388	0	4.528
0	4.388	0	4.428	0	4.448	0	4.528
0	4.388	0	4.428	0	4.428	0	4.548
0	4.408	0	4.428	0	4.428	0	4.508
0	4.408	0	4.428	0	4.408	0	4.568
0	4.408	0	4.408	0	4.408	0	4.468
0	4.408	0	4.388	0	4.428	0	4.528
0	4.388	0	4.428	0	4.368	0	4.508
0	4.408	0	4.408	0	4.408	0	4.548
0	4.408	0	4.348	0	4.408	0	4.528
0	4.388	0	4.428	0	4.388	0	4.528
0	4.388	0	4.428	0	4.408	0	4.508
0	4.388	0	4.408	0	4.428	0	4.528
0	4.388	0	4.428	0	4.428	0	4.528
0	4.408	0	4.368	0	4.428	0	4.488
0	4.388	0	4.428	0	4.408	0	4.468
0	4.408	0	4.408	0	4.428	0	4.508
0	4.408	0	4.408	0	4.428	0	4.528
2000.24	6.430	2000.57	6.410	2001.41	6.410	2000.71	6.530
2000.24	6.410	2000.57	6.470	2001.41	6.450	2000.71	6.470
2000.24	6.410	2000.57	6.470	2001.41	6.450	2000.71	6.490
2000.24	6.410	2000.57	6.470	2001.41	6.470	2000.71	6.490
2000.24	6.370	2000.57	6.450	2001.41	6.430	2000.71	6.530
2000.24	6.390	2000.57	6.430	2001.41	6.430	2000.71	6.530
2000.24	6.390	2000.57	6.430	2001.41	6.470	2000.71	6.510
2000.24	6.450	2000.57	6.410	2001.41	6.450	2000.71	6.470
2000.24	6.430	2000.57	6.450	2001.41	6.490	2000.71	6.490
2000.24	6.370	2000.57	6.410	2001.41	6.470	2000.71	6.510
2000.24	6.390	2000.57	6.430	2001.41	6.410	2000.71	6.530
2000.24	6.390	2000.57	6.470	2001.41	6.470	2000.71	6.510
2000.24	6.410	2000.57	6.450	2001.41	6.430	2000.71	6.530
2000.24	6.430	2000.57	6.470	2001.41	6.430	2000.71	6.510
2000.24	6.410	2000.57	6.430	2001.41	6.490	2000.71	6.510
2000.24	6.410	2000.57	6.430	2001.41	6.430	2000.71	6.490
2000.24	6.410	2000.57	6.470	2001.41	6.470	2000.71	6.530
2000.24	6.390	2000.57	6.450	2001.41	6.490	2000.71	6.490
2000.24	6.410	2000.57	6.450	2001.41	6.430	2000.71	6.510
2000.24	6.430	2000.57	6.450	2001.41	6.430	2000.71	6.510
2000.24	6.430	2000.57	6.450	2001.41	6.450	2000.71	6.490
2000.24	6.390	2000.57	6.410	2001.41	6.390	2000.71	6.550
2000.24	6.430	2000.57	6.450	2001.41	6.430	2000.71	6.490
2000.24	6.410	2000.57	6.430	2001.41	6.430	2000.71	6.550
2000.24	6.430	2000.57	6.470	2001.41	6.470	2000.71	6.510
4009.75	8.473	3998.67	8.373	3998.68	8.473	4000.15	8.433
4009.75	8.453	3998.67	8.433	3998.68	8.473	4000.15	8.453
4009.75	8.413	3998.67	8.413	3998.68	8.513	4000.15	8.393
4009.75	8.453	3998.67	8.413	3998.68	8.453	4000.15	8.413
4009.75	8.433	3998.67	8.393	3998.68	8.513	4000.15	8.453
4009.75	8.493	3998.67	8.393	3998.68	8.513	4000.15	8.473
4009.75	8.453	3998.67	8.413	3998.68	8.473	4000.15	8.473

Table A.1 Data Set1 - Relative Distance Calibration: 0 m to 60 m

Location: Environmentally controlled lab, Bldg. 220				File: rel_dist_anal.xls			
No Filter							
Test dates: July 14-15, 1999							
Interfero. Dist. (mm)	Blck, not shiny (m)	Interfero. Dist. (mm)	Blck, shiny (m)	Interfero. Dist. (mm)	Dk. Grey, rough (m)	Interfero. Dist. (mm)	Pink, not shiny (m)
4009.75	8.433	3998.67	8.373	3998.68	8.473	4000.15	8.453
4009.75	8.433	3998.67	8.373	3998.68	8.453	4000.15	8.473
4009.75	8.433	3998.67	8.433	3998.68	8.453	4000.15	8.393
4009.75	8.453	3998.67	8.373	3998.68	8.453	4000.15	8.433
4009.75	8.493	3998.67	8.413	3998.68	8.453	4000.15	8.433
4009.75	8.433	3998.67	8.393	3998.68	8.433	4000.15	8.413
4009.75	8.433	3998.67	8.393	3998.68	8.493	4000.15	8.453
4009.75	8.453	3998.67	8.433	3998.68	8.553	4000.15	8.433
4009.75	8.433	3998.67	8.433	3998.68	8.473	4000.15	8.413
4009.75	8.433	3998.67	8.433	3998.68	8.413	4000.15	8.433
4009.75	8.433	3998.67	8.373	3998.68	8.433	4000.15	8.413
4009.75	8.433	3998.67	8.433	3998.68	8.493	4000.15	8.393
4009.75	8.473	3998.67	8.433	3998.68	8.493	4000.15	8.473
4009.75	8.433	3998.67	8.413	3998.68	8.493	4000.15	8.433
4009.75	8.453	3998.67	8.373	3998.68	8.453	4000.15	8.433
4009.75	8.453	3998.67	8.433	3998.68	8.433	4000.15	8.433
4009.75	8.453	3998.67	8.413	3998.68	8.453	4000.15	8.433
4009.75	8.473	3998.67	8.393	3998.68	8.453	4000.15	8.453
6001.70	10.456	6000.67	10.416	5999.74	10.496	6001.67	10.416
6001.70	10.416	6000.67	10.356	5999.74	10.456	6001.67	10.436
6001.70	10.416	6000.67	10.376	5999.74	10.416	6001.67	10.456
6001.70	10.396	6000.67	10.436	5999.74	10.476	6001.67	10.396
6001.70	10.436	6000.67	10.396	5999.74	10.396	6001.67	10.356
6001.70	10.396	6000.67	10.396	5999.74	10.476	6001.67	10.496
6001.70	10.416	6000.67	10.376	5999.74	10.416	6001.67	10.396
6001.70	10.476	6000.67	10.396	5999.74	10.456	6001.67	10.436
6001.70	10.436	6000.67	10.416	5999.74	10.496	6001.67	10.476
6001.70	10.416	6000.67	10.396	5999.74	10.456	6001.67	10.416
6001.70	10.476	6000.67	10.416	5999.74	10.436	6001.67	10.456
6001.70	10.456	6000.67	10.416	5999.74	10.456	6001.67	10.456
6001.70	10.416	6000.67	10.396	5999.74	10.476	6001.67	10.456
6001.70	10.416	6000.67	10.416	5999.74	10.476	6001.67	10.416
6001.70	10.456	6000.67	10.416	5999.74	10.436	6001.67	10.396
6001.70	10.416	6000.67	10.356	5999.74	10.456	6001.67	10.456
6001.70	10.476	6000.67	10.396	5999.74	10.496	6001.67	10.456
6001.70	10.456	6000.67	10.436	5999.74	10.416	6001.67	10.436
6001.70	10.416	6000.67	10.376	5999.74	10.496	6001.67	10.436
6001.70	10.376	6000.67	10.396	5999.74	10.476	6001.67	10.436
6001.70	10.456	6000.67	10.396	5999.74	10.456	6001.67	10.436
6001.70	10.436	6000.67	10.456	5999.74	10.476	6001.67	10.436
6001.70	10.436	6000.67	10.416	5999.74	10.456	6001.67	10.476
6001.70	10.456	6000.67	10.396	5999.74	10.436	6001.67	10.436
6001.70	10.456	6000.67	10.416	5999.74	10.456	6001.67	10.456
7999.24	12.439	7998.05	12.399	7998.77	12.439	8000.42	12.439
7999.24	12.459	7998.05	12.399	7998.77	12.459	8000.42	12.459
7999.24	12.419	7998.05	12.399	7998.77	12.500	8000.42	12.479
7999.24	12.459	7998.05	12.419	7998.77	12.500	8000.42	12.439
7999.24	12.459	7998.05	12.399	7998.77	12.479	8000.42	12.439
7999.24	12.479	7998.05	12.419	7998.77	12.439	8000.42	12.399
7999.24	12.459	7998.05	12.419	7998.77	12.439	8000.42	12.439
7999.24	12.479	7998.05	12.419	7998.77	12.500	8000.42	12.479
7999.24	12.439	7998.05	12.419	7998.77	12.500	8000.42	12.439
7999.24	12.479	7998.05	12.399	7998.77	12.439	8000.42	12.479
7999.24	12.439	7998.05	12.439	7998.77	12.459	8000.42	12.419
7999.24	12.459	7998.05	12.439	7998.77	12.439	8000.42	12.439
7999.24	12.459	7998.05	12.419	7998.77	12.479	8000.42	12.459
7999.24	12.439	7998.05	12.399	7998.77	12.479	8000.42	12.419
7999.24	12.459	7998.05	12.379	7998.77	12.439	8000.42	12.459
7999.24	12.419	7998.05	12.419	7998.77	12.459	8000.42	12.459
7999.24	12.439	7998.05	12.379	7998.77	12.479	8000.42	12.419

Table A.1 Data Set1 - Relative Distance Calibration: 0 m to 60 m

Location: Environmentally controlled lab, Bldg. 220				File: rel_dist_anal.xls			
No Filter							
Test dates: July 14-15, 1999							
Interfero. Dist. (mm)	Blck, not shiny (m)	Interfero. Dist. (mm)	Blck, shiny (m)	Interfero. Dist. (mm)	Dk. Grey, rough (m)	Interfero. Dist. (mm)	Pink, not shiny (m)
7999.24	12.459	7998.05	12.399	7998.77	12.439	8000.42	12.439
7999.24	12.459	7998.05	12.399	7998.77	12.439	8000.42	12.459
7999.24	12.459	7998.05	12.399	7998.77	12.479	8000.42	12.419
7999.24	12.439	7998.05	12.419	7998.77	12.459	8000.42	12.399
7999.24	12.459	7998.05	12.399	7998.77	12.459	8000.42	12.439
7999.24	12.459	7998.05	12.379	7998.77	12.419	8000.42	12.479
7999.24	12.500	7998.05	12.439	7998.77	12.459	8000.42	12.419
7999.24	12.459	7998.05	12.419	7998.77	12.479	8000.42	12.439
10000.69	14.443	9999.7	14.363	9999.81	14.463	10000.91	14.463
10000.69	14.423	9999.7	14.383	9999.81	14.463	10000.91	14.443
10000.69	14.483	9999.7	14.363	9999.81	14.504	10000.91	14.463
10000.69	14.443	9999.7	14.423	9999.81	14.403	10000.91	14.403
10000.69	14.463	9999.7	14.383	9999.81	14.483	10000.91	14.443
10000.69	14.423	9999.7	14.363	9999.81	14.463	10000.91	14.463
10000.69	14.443	9999.7	14.383	9999.81	14.504	10000.91	14.483
10000.69	14.443	9999.7	14.383	9999.81	14.463	10000.91	14.443
10000.69	14.403	9999.7	14.383	9999.81	14.483	10000.91	14.423
10000.69	14.443	9999.7	14.403	9999.81	14.423	10000.91	14.463
10000.69	14.443	9999.7	14.403	9999.81	14.483	10000.91	14.423
10000.69	14.423	9999.7	14.383	9999.81	14.463	10000.91	14.423
10000.69	14.443	9999.7	14.423	9999.81	14.443	10000.91	14.443
10000.69	14.463	9999.7	14.383	9999.81	14.483	10000.91	14.483
10000.69	14.423	9999.7	14.403	9999.81	14.483	10000.91	14.483
10000.69	14.443	9999.7	14.403	9999.81	14.499	10000.91	14.403
10000.69	14.443	9999.7	14.363	9999.81	14.483	10000.91	14.463
10000.69	14.463	9999.7	14.363	9999.81	14.463	10000.91	14.463
10000.69	14.443	9999.7	14.403	9999.81	14.483	10000.91	14.463
10000.69	14.463	9999.7	14.423	9999.81	14.463	10000.91	14.483
10000.69	14.443	9999.7	14.383	9999.81	14.443	10000.91	14.463
10000.69	14.443	9999.7	14.423	9999.81	14.463	10000.91	14.443
10000.69	14.483	9999.7	14.403	9999.81	14.443	10000.91	14.483
10000.69	14.443	9999.7	14.363	9999.81	14.483	10000.91	14.443
14996.22	19.425	14995.35	19.405	14996.92	19.505	14996.90	19.465
14996.22	19.445	14995.35	19.405	14996.92	19.425	14996.90	19.385
14996.22	19.405	14995.35	19.405	14996.92	19.465	14996.90	19.445
14996.22	19.445	14995.35	19.425	14996.92	19.485	14996.90	19.445
14996.22	19.425	14995.35	19.445	14996.92	19.385	14996.90	19.445
14996.22	19.385	14995.35	19.405	14996.92	19.485	14996.90	19.445
14996.22	19.445	14995.35	19.405	14996.92	19.485	14996.90	19.425
14996.22	19.445	14995.35	19.425	14996.92	19.445	14996.90	19.425
14996.22	19.465	14995.35	19.385	14996.92	19.425	14996.90	19.425
14996.22	19.445	14995.35	19.385	14996.92	19.505	14996.90	19.485
14996.22	19.425	14995.35	19.405	14996.92	19.445	14996.90	19.445
14996.22	19.445	14995.35	19.425	14996.92	19.445	14996.90	19.425
14996.22	19.425	14995.35	19.445	14996.92	19.525	14996.90	19.445
14996.22	19.445	14995.35	19.385	14996.92	19.485	14996.90	19.485
14996.22	19.485	14995.35	19.405	14996.92	19.445	14996.90	19.485
14996.22	19.425	14995.35	19.445	14996.92	19.505	14996.90	19.445
14996.22	19.405	14995.35	19.425	14996.92	19.465	14996.90	19.425
14996.22	19.465	14995.35	19.405	14996.92	19.485	14996.90	19.465
14996.22	19.425	14995.35	19.405	14996.92	19.445	14996.90	19.385
14996.22	19.465	14995.35	19.405	14996.92	19.445	14996.90	19.425
14996.22	19.465	14995.35	19.405	14996.92	19.485	14996.90	19.385
14996.22	19.405	14995.35	19.385	14996.92	19.505	14996.90	19.425
14996.22	19.465	14995.35	19.405	14996.92	19.445	14996.90	19.445
14996.22	19.465	14995.35	19.465	14996.92	19.465	14996.90	19.445
14996.22	19.465	14995.35	19.405	14996.92	19.465	14996.90	19.425
20009.44	24.525	20011.32	24.465	20010.28	24.545	20011.23	24.465
20009.44	24.465	20011.32	24.445	20010.28	24.505	20011.23	24.465

Table A.1 Data Set1 - Relative Distance Calibration: 0 m to 60 m

Location: Environmentally controlled lab, Bldg. 220				File: rel_dist_anal.xls			
No Filter							
Test dates: July 14-15, 1999							
Interfero. Dist. (mm)	Blck, not shiny (m)	Interfero. Dist. (mm)	Blck, shiny (m)	Interfero. Dist. (mm)	Dk. Grey, rough (m)	Interfero. Dist. (mm)	Pink, not shiny (m)
20009.44	24.425	20011.32	24.445	20010.28	24.545	20011.23	24.445
20009.44	24.485	20011.32	24.485	20010.28	24.505	20011.23	24.445
20009.44	24.485	20011.32	24.485	20010.28	24.565	20011.23	24.445
20009.44	24.445	20011.32	24.465	20010.28	24.525	20011.23	24.465
20009.44	24.425	20011.32	24.425	20010.28	24.565	20011.23	24.445
20009.44	24.485	20011.32	24.425	20010.28	24.525	20011.23	24.465
20009.44	24.465	20011.32	24.465	20010.28	24.485	20011.23	24.465
20009.44	24.505	20011.32	24.445	20010.28	24.585	20011.23	24.425
20009.44	24.485	20011.32	24.465	20010.28	24.505	20011.23	24.445
20009.44	24.425	20011.32	24.465	20010.28	24.425	20011.23	24.425
20009.44	24.445	20011.32	24.465	20010.28	24.525	20011.23	24.445
20009.44	24.465	20011.32	24.405	20010.28	24.505	20011.23	24.445
20009.44	24.445	20011.32	24.425	20010.28	24.445	20011.23	24.465
20009.44	24.445	20011.32	24.405	20010.28	24.545	20011.23	24.445
20009.44	24.505	20011.32	24.425	20010.28	24.545	20011.23	24.405
20009.44	24.485	20011.32	24.465	20010.28	24.545	20011.23	24.445
20009.44	24.465	20011.32	24.465	20010.28	24.545	20011.23	24.465
20009.44	24.445	20011.32	24.425	20010.28	24.485	20011.23	24.465
20009.44	24.465	20011.32	24.485	20010.28	24.545	20011.23	24.465
20009.44	24.425	20011.32	24.465	20010.28	24.485	20011.23	24.480
20009.44	24.445	20011.32	24.405	20010.28	24.485	20011.23	24.445
20009.44	24.465	20011.32	24.485	20010.28	24.505	20011.23	24.465
20009.44	24.465	20011.32	24.445	20010.28	24.485	20011.23	24.485
30003.46	34.405	30003.76	34.485	30005.96	34.525	30007.11	34.465
30003.46	34.565	30003.76	34.545	30005.96	34.705	30007.11	34.425
30003.46	34.545	30003.76	34.525	30005.96	34.625	30007.11	34.485
30003.46	34.545	30003.76	34.465	30005.96	34.625	30007.11	34.425
30003.46	34.505	30003.76	34.545	30005.96	34.585	30007.11	34.485
30003.46	34.525	30003.76	34.465	30005.96	34.545	30007.11	34.425
30003.46	34.565	30003.76	34.485	30005.96	34.505	30007.11	34.425
30003.46	34.525	30003.76	34.505	30005.96	34.605	30007.11	34.425
30003.46	34.525	30003.76	34.445	30005.96	34.645	30007.11	34.445
30003.46	34.000	30003.76	34.505	30005.96	34.605	30007.11	34.465
30003.46	34.545	30003.76	34.485	30005.96	34.525	30007.11	34.445
30003.46	34.465	30003.76	34.485	30005.96	34.585	30007.11	34.385
30003.46	34.525	30003.76	34.505	30005.96	34.585	30007.11	34.485
30003.46	34.465	30003.76	34.505	30005.96	34.525	30007.11	34.425
30003.46	34.485	30003.76	34.505	30005.96	34.545	30007.11	34.465
30003.46	34.545	30003.76	34.485	30005.96	34.525	30007.11	34.485
30003.46	34.505	30003.76	34.505	30005.96	34.505	30007.11	34.465
30003.46	34.585	30003.76	34.485	30005.96	34.625	30007.11	34.425
30003.46	34.465	30003.76	34.465	30005.96	34.605	30007.11	34.485
30003.46	34.545	30003.76	34.505	30005.96	34.645	30007.11	34.425
30003.46	34.625	30003.76	34.445	30005.96	34.485	30007.11	34.445
30003.46	34.545	30003.76	34.485	30005.96	34.565	30007.11	34.465
30003.46	34.445	30003.76	34.485	30005.96	34.565	30007.11	34.445
30003.46	34.585	30003.76	34.485	30005.96	34.505	30007.11	34.420
30003.46	34.445	30003.76	34.405	30005.96	34.465	30007.11	34.405
39961.74	44.405	39963.03	44.485	39963.32	44.485	39965.70	44.425
39961.74	44.505	39963.03	44.465	39963.32	44.405	39965.70	44.405
39961.74	44.505	39963.03	44.545	39963.32	44.465	39965.70	44.425
39961.74	44.505	39963.03	44.445	39963.32	44.525	39965.70	44.405
39961.74	44.545	39963.03	44.465	39963.32	44.445	39965.70	44.445
39961.74	44.465	39963.03	44.485	39963.32	44.485	39965.70	44.425
39961.74	44.545	39963.03	44.405	39963.32	44.485	39965.70	44.425
39961.74	44.465	39963.03	44.465	39963.32	44.585	39965.70	44.365
39961.74	44.525	39963.03	44.465	39963.32	44.605	39965.70	44.385
39961.74	44.565	39963.03	44.465	39963.32	44.445	39965.70	44.445
39961.74	44.405	39963.03	44.465	39963.32	44.585	39965.70	44.405
39961.74	44.485	39963.03	44.485	39963.32	44.445	39965.70	44.385

Table A.1 Data Set1 - Relative Distance Calibration: 0 m to 60 m

Location: Environmentally controlled lab, Bldg. 220				File: rel_dist_anal.xls			
No Filter							
Test dates: July 14-15, 1999							
Interfero. Dist. (mm)	Blck, not shiny (m)	Interfero. Dist. (mm)	Blck, shiny (m)	Interfero. Dist. (mm)	Dk. Grey, rough (m)	Interfero. Dist. (mm)	Pink, not shiny (m)
39961.74	44.505	39963.03	44.445	39963.32	44.565	39965.70	44.405
39961.74	44.605	39963.03	44.485	39963.32	44.525	39965.70	44.405
39961.74	44.545	39963.03	44.505	39963.32	44.525	39965.70	44.385
39961.74	44.545	39963.03	44.485	39963.32	44.465	39965.70	44.425
39961.74	44.605	39963.03	44.465	39963.32	44.525	39965.70	44.445
39961.74	44.605	39963.03	44.485	39963.32	44.505	39965.70	44.405
39961.74	44.485	39963.03	44.465	39963.32	44.405	39965.70	44.445
39961.74	44.445	39963.03	44.485	39963.32	44.425	39965.70	44.385
39961.74	44.605	39963.03	44.365	39963.32	44.445	39965.70	44.385
39961.74	44.505	39963.03	44.445	39963.32	44.665	39965.70	44.405
39961.74	44.505	39963.03	44.405	39963.32	44.605	39965.70	44.385
39961.74	44.485	39963.03	44.445	39963.32	44.445	39965.70	44.385
39961.74	44.505	39963.03	44.425	39963.32	44.645	39965.70	44.425
		49914.07	54.565			49926.43	54.465
		49914.07	54.465			49926.43	54.465
		49914.07	54.465			49926.43	54.445
		49914.07	54.585			49926.43	54.385
		49914.07	54.525			49926.43	54.405
		49914.07	54.405			49926.43	54.445
		49914.07	54.545			49926.43	54.445
		49914.07	54.425			49926.43	54.465
		49914.07	54.565			49926.43	54.445
		49914.07	54.405			49926.43	54.385
		49914.07	54.485			49926.43	54.425
		49914.07	54.465			49926.43	54.465
		49914.07	54.445			49926.43	54.485
		49914.07	54.485			49926.43	54.465
		49914.07	54.485			49926.43	54.405
		49914.07	54.485			49926.43	54.405
		49914.07	54.525			49926.43	54.405
		49914.07	54.565			49926.43	54.445
		49914.07	54.585			49926.43	54.385
		49914.07	54.385			49926.43	54.485
		49914.07	54.345			49926.43	54.445
		49914.07	54.445			49926.43	54.465
		49914.07	54.365			49926.43	54.465
		49914.07	54.485			49926.43	54.445
		49914.07	54.405			49926.43	54.425

Table A.1 Data Set 1 - Relative Distance Calibration: 0 m to 60 m

Location: Environmentally controlled lab, Bldg. 220 No Filter File: rel_dist_anal.xls Test dates: July 14-15, 1999				Location: Environmentally controlled lab, Bldg. 220 No Filter File: 8_22_99_laser.xls Test date: Aug. 2, 1999	
Interfero. Dist. (mm)	Yllw, not shiny (m)	Interfero. Dist. (mm)	Grn, not shiny (m)	Interfero. Dist. (mm)	Grn, not shiny – recal. (m)
0	4.463	0.00	4.448	0.00	4.451
0	4.431	0.00	4.468	0.00	4.447
0	4.407	0.00	4.448	0.00	4.431
0	4.427	0.00	4.468	0.00	4.451
0	4.427	0.00	4.448	0.00	4.447
0	4.427	0.00	4.468	0.00	4.427
0	4.407	0.00	4.468	0.00	4.411
0	4.427	0.00	4.428	0.00	4.467
0	4.447	0.00	4.468	0.00	4.431
0	4.447	0.00	4.468	0.00	4.447
0	4.387	0.00	4.448	0.00	4.447
0	4.427	0.00	4.448	0.00	4.427
0	4.427	0.00	4.468	0.00	4.447
0	4.427	0.00	4.448	0.00	4.447
0	4.427	0.00	4.448	0.00	4.447
0	4.427	0.00	4.448	0.00	4.427
0	4.407	0.00	4.468	0.00	4.467
0	4.407	0.00	4.468	0.00	4.427
0	4.407	0.00	4.428	0.00	4.427
0	4.427	0.00	4.448	0.00	4.427
0	4.407	0.00	4.448	0.00	4.447
0	4.407	0.00	4.468	0.00	4.447
0	4.387	0.00	4.428	0.00	4.447
0	4.407	0.00	4.448	0.00	4.467
0	4.407	0.00	4.448	2000.58	6.433
2001.73	6.469	2000.88	6.450	2000.58	6.453
2001.73	6.449	2000.88	6.450	2000.58	6.453
2001.73	6.449	2000.88	6.470	2000.58	6.473
2001.73	6.389	2000.88	6.450	2000.58	6.453
2001.73	6.409	2000.88	6.490	2000.58	6.493
2001.73	6.449	2000.88	6.450	2000.58	6.453
2001.73	6.409	2000.88	6.490	2000.58	6.473
2001.73	6.449	2000.88	6.470	2000.58	6.473
2001.73	6.389	2000.88	6.430	2000.58	6.433
2001.73	6.449	2000.88	6.490	2000.58	6.473
2001.73	6.429	2000.88	6.490	2000.58	6.453
2001.73	6.429	2000.88	6.490	2000.58	6.453
2001.73	6.429	2000.88	6.470	2000.58	6.433
2001.73	6.429	2000.88	6.450	2000.58	6.473
2001.73	6.424	2000.88	6.490	2000.58	6.473
2001.73	6.429	2000.88	6.450	2000.58	6.493
2001.73	6.409	2000.88	6.470	2000.58	6.473
2001.73	6.389	2000.88	6.430	2000.58	6.433
2001.73	6.449	2000.88	6.490	2000.58	6.473
2001.73	6.429	2000.88	6.490	2000.58	6.453
2001.73	6.404	2000.88	6.470	2000.58	6.473
2001.73	6.404	2000.88	6.510	2000.58	6.493
2001.73	6.429	2000.88	6.490	2000.58	6.493
2001.73	6.404	2000.88	6.470	2000.58	6.493
2001.73	6.404	2000.88	6.490	2000.58	6.453
2001.73	6.424	2000.88	6.490	2000.58	6.473
2001.73	6.469	2000.88	6.470	2000.58	6.493
2001.73	6.424	2000.88	6.490	2000.58	6.433
2001.73	6.404	2000.88	6.470	2000.58	6.473
4000.01	8.447	4000.17	8.473	4000.36	8.472
4000.01	8.447	4000.17	8.453	4000.36	8.452
4000.01	8.467	4000.17	8.473	4000.36	8.452
4000.01	8.447	4000.17	8.433	4000.36	8.492
4000.01	8.447	4000.17	8.493	4000.36	8.472
4000.01	8.407	4000.17	8.493	4000.36	8.472

Table A.1 Data Set 1 - Relative Distance Calibration: 0 m to 60 m

Location: Environmentally controlled lab, Bldg. 220 No Filter File: rel_dist_anal.xls Test dates: July 14-15, 1999				Location: Environmentally controlled lab, Bldg. 220 No Filter File: 8_22_99_laser.xls Test date: Aug. 2, 1999	
Interfero. Dist. (mm)	Yllw, not shiny (m)	Interfero. Dist. (mm)	Grn, not shiny (m)	Interfero. Dist. (mm)	Grn, not shiny – recal. (m)
4000.01	8.447	4000.17	8.453	4000.36	8.472
4000.01	8.467	4000.17	8.433	4000.36	8.452
4000.01	8.427	4000.17	8.473	4000.36	8.472
4000.01	8.467	4000.17	8.473	4000.36	8.472
4000.01	8.447	4000.17	8.473	4000.36	8.452
4000.01	8.427	4000.17	8.433	4000.36	8.472
4000.01	8.447	4000.17	8.473	4000.36	8.472
4000.01	8.427	4000.17	8.493	4000.36	8.432
4000.01	8.447	4000.17	8.493	4000.36	8.492
4000.01	8.447	4000.17	8.473	4000.36	8.472
4000.01	8.427	4000.17	8.453	4000.36	8.452
4000.01	8.407	4000.17	8.453	4000.36	8.472
4000.01	8.427	4000.17	8.473	4000.36	8.432
4000.01	8.427	4000.17	8.473	4000.36	8.472
4000.01	8.447	4000.17	8.433	4000.36	8.512
4000.01	8.447	4000.17	8.493	4000.36	8.472
4000.01	8.467	4000.17	8.433	4000.36	8.472
4000.01	8.407	4000.17	8.473	4000.36	8.492
4000.01	8.407	4000.17	8.473	4000.36	8.452
6000.09	10.430	6000.18	10.456	5999.05	10.475
6000.09	10.450	6000.18	10.476	5999.05	10.490
6000.09	10.470	6000.18	10.476	5999.05	10.470
6000.09	10.450	6000.18	10.476	5999.05	10.450
6000.09	10.430	6000.18	10.496	5999.05	10.470
6000.09	10.410	6000.18	10.476	5999.05	10.490
6000.09	10.430	6000.18	10.476	5999.05	10.510
6000.09	10.450	6000.18	10.456	5999.05	10.490
6000.09	10.430	6000.18	10.476	5999.05	10.470
6000.09	10.450	6000.18	10.496	5999.05	10.430
6000.09	10.450	6000.18	10.476	5999.05	10.490
6000.09	10.450	6000.18	10.496	5999.05	10.490
6000.09	10.450	6000.18	10.496	5999.05	10.450
6000.09	10.450	6000.18	10.476	5999.05	10.450
6000.09	10.470	6000.18	10.456	5999.05	10.490
6000.09	10.430	6000.18	10.516	5999.05	10.510
6000.09	10.470	6000.18	10.516	5999.05	10.450
6000.09	10.390	6000.18	10.496	5999.05	10.470
6000.09	10.430	6000.18	10.496	5999.05	10.430
6000.09	10.430	6000.18	10.496	5999.05	10.490
6000.09	10.410	6000.18	10.476	5999.05	10.490
6000.09	10.470	6000.18	10.456	5999.05	10.490
6000.09	10.390	6000.18	10.456	5999.05	10.450
6000.09	10.430	6000.18	10.496	5999.05	10.470
6000.09	10.430	6000.18	10.496	5999.05	10.490
8000.24	12.453	8001.45	12.479	8000.17	12.493
8000.24	12.453	8001.45	12.479	8000.17	12.488
8000.24	12.433	8001.45	12.479	8000.17	12.468
8000.24	12.433	8001.45	12.479	8000.17	12.488
8000.24	12.433	8001.45	12.479	8000.17	12.488
8000.24	12.428	8001.45	12.479	8000.17	12.468
8000.24	12.413	8001.45	12.500	8000.17	12.488
8000.24	12.433	8001.45	12.479	8000.17	12.468
8000.24	12.453	8001.45	12.479	8000.17	12.488
8000.24	12.433	8001.45	12.479	8000.17	12.468
8000.24	12.433	8001.45	12.479	8000.17	12.468
8000.24	12.448	8001.45	12.479	8000.17	12.488
8000.24	12.413	8001.45	12.479	8000.17	12.488

Table A.1 Data Set 1 - Relative Distance Calibration: 0 m to 60 m

Location: Environmentally controlled lab, Bldg. 220 No Filter File: rel_dist_anal.xls Test dates: July 14-15, 1999				Location: Environmentally controlled lab, Bldg. 220 No Filter File: 8_22_99_laser.xls Test date: Aug. 2, 1999	
Interfero. Dist. (mm)	Yllw, not shiny (m)	Interfero. Dist. (mm)	Grn, not shiny (m)	Interfero. Dist. (mm)	Grn, not shiny – recal. (m)
8000.24	12.453	8001.45	12.479	8000.17	12.488
8000.24	12.433	8001.45	12.479	8000.17	12.488
8000.24	12.433	8001.45	12.479	8000.17	12.488
8000.24	12.433	8001.45	12.459	8000.17	12.488
8000.24	12.433	8001.45	12.479	8000.17	12.468
8000.24	12.443	8001.45	12.479	8000.17	12.468
8000.24	12.413	8001.45	12.479	8000.17	12.468
8000.24	12.453	8001.45	12.479	8000.17	12.468
8000.24	12.433	8001.45	12.479	8000.17	12.468
8000.24	12.428	8001.45	12.479	8000.17	12.488
8000.24	12.408	8001.45	12.479	8000.17	12.488
8000.24	12.428	8001.45	12.479	8000.17	12.448
9999.92	14.432	10000.87	14.463	10002.66	14.472
9999.92	14.412	10000.87	14.463	10002.66	14.492
9999.92	14.412	10000.87	14.463	10002.66	14.492
9999.92	14.412	10000.87	14.443	10002.66	14.452
9999.92	14.412	10000.87	14.483	10002.66	14.472
9999.92	14.432	10000.87	14.483	10002.66	14.432
9999.92	14.412	10000.87	14.443	10002.66	14.432
9999.92	14.412	10000.87	14.463	10002.66	14.472
9999.92	14.412	10000.87	14.463	10002.66	14.472
9999.92	14.412	10000.87	14.463	10002.66	14.432
9999.92	14.392	10000.87	14.463	10002.66	14.452
9999.92	14.412	10000.87	14.483	10002.66	14.492
9999.92	14.412	10000.87	14.483	10002.66	14.472
9999.92	14.412	10000.87	14.483	10002.66	14.452
9999.92	14.412	10000.87	14.483	10002.66	14.472
9999.92	14.412	10000.87	14.483	10002.66	14.472
9999.92	14.412	10000.87	14.463	10002.66	14.472
9999.92	14.412	10000.87	14.463	10002.66	14.452
9999.92	14.432	10000.87	14.463	10002.66	14.472
9999.92	14.412	10000.87	14.483	10002.66	14.452
9999.92	14.432	10000.87	14.483	10002.66	14.492
9999.92	14.412	10000.87	14.483	10002.66	14.472
9999.92	14.412	10000.87	14.423	10002.66	14.492
9999.92	14.412	10000.87	14.463	10002.66	14.432
9999.92	14.412	10000.87	14.463	10002.66	14.472
14996.48	19.414	14998.16	19.445	14990.23	19.414
14996.48	19.434	14998.16	19.405	14990.23	19.390
14996.48	19.434	14998.16	19.405	14990.23	19.410
14996.48	19.394	14998.16	19.405	14990.23	19.410
14996.48	19.434	14998.16	19.445	14990.23	19.410
14996.48	19.454	14998.16	19.445	14990.23	19.410
14996.48	19.434	14998.16	19.405	14990.23	19.414
14996.48	19.434	14998.16	19.425	14990.23	19.394
14996.48	19.414	14998.16	19.445	14990.23	19.390
14996.48	19.434	14998.16	19.445	14990.23	19.430
14996.48	19.414	14998.16	19.425	14990.23	19.410
14996.48	19.414	14998.16	19.445	14990.23	19.430
14996.48	19.434	14998.16	19.425	14990.23	19.370
14996.48	19.434	14998.16	19.445	14990.23	19.430
14996.48	19.434	14998.16	19.445	14990.23	19.430
14996.48	19.434	14998.16	19.445	14990.23	19.430
14996.48	19.414	14998.16	19.405	14990.23	19.430
14996.48	19.414	14998.16	19.405	14990.23	19.430
14996.48	19.414	14998.16	19.465	14990.23	19.410
14996.48	19.414	14998.16	19.405	14990.23	19.410
14996.48	19.414	14998.16	19.385	14990.23	19.410

Table A.1 Data Set 1 - Relative Distance Calibration: 0 m to 60 m

Location: Environmentally controlled lab, Bldg. 220 No Filter File: rel_dist_anal.xls Test dates: July 14-15, 1999				Location: Environmentally controlled lab, Bldg. 220 No Filter File: 8_22_99_laser.xls Test date: Aug. 2, 1999	
Interfero. Dist. (mm)	Yllw, not shiny (m)	Interfero. Dist. (mm)	Grn, not shiny (m)	Interfero. Dist. (mm)	Grn, not shiny – recal. (m)
14996.48	19.434	14998.16	19.385	14990.23	19.410
14996.48	19.454	14998.16	19.405	14990.23	19.430
14996.48	19.434	14998.16	19.385	14990.23	19.394
14996.48	19.454	14998.16	19.385	14990.23	19.370
14996.48	19.434	14998.16	19.425	14990.23	19.390
20010.77	24.434	20010.10	24.405	19990.03	24.390
20010.77	24.434	20010.10	24.445	19990.03	24.410
20010.77	24.434	20010.10	24.405	19990.03	24.390
20010.77	24.434	20010.10	24.405	19990.03	24.390
20010.77	24.434	20010.10	24.405	19990.03	24.390
20010.77	24.434	20010.10	24.425	19990.03	24.390
20010.77	24.454	20010.10	24.405	19990.03	24.390
20010.77	24.434	20010.10	24.425	19990.03	24.390
20010.77	24.454	20010.10	24.405	19990.03	24.390
20010.77	24.474	20010.10	24.425	19990.03	24.410
20010.77	24.454	20010.10	24.425	19990.03	24.430
20010.77	24.454	20010.10	24.405	19990.03	24.370
20010.77	24.454	20010.10	24.425	19990.03	24.410
20010.77	24.434	20010.10	24.445	19990.03	24.390
20010.77	24.454	20010.10	24.425	19990.03	24.390
20010.77	24.545	20010.10	24.405	19990.03	24.370
20010.77	24.454	20010.10	24.445	19990.03	24.410
20010.77	24.454	20010.10	24.425	19990.03	24.370
20010.77	24.434	20010.10	24.405	19990.03	24.410
20010.77	24.414	20010.10	24.425	19990.03	24.410
20010.77	24.454	20010.10	24.405	19990.03	24.410
20010.77	24.454	20010.10	24.425	19990.03	24.410
20010.77	24.434	20010.10	24.425	19990.03	24.410
20010.77	24.454	20010.10	24.385	19990.03	24.390
20010.77	24.454	20010.10	24.425	19990.03	24.390
30006.01	34.450	30006.19	34.425	30524.89	34.970
30006.01	34.430	30006.19	34.445	30524.89	34.950
30006.01	34.445	30006.19	34.465	30524.89	34.950
30006.01	34.425	30006.19	34.405	30524.89	34.930
30006.01	34.425	30006.19	34.445	30524.89	34.950
30006.01	34.445	30006.19	34.425	30524.89	34.950
30006.01	34.485	30006.19	34.485	30524.89	34.970
30006.01	34.445	30006.19	34.425	30524.89	34.970
30006.01	34.465	30006.19	34.425	30524.89	34.950
30006.01	34.465	30006.19	34.425	30524.89	34.990
30006.01	34.465	30006.19	34.425	30524.89	34.970
30006.01	34.445	30006.19	34.425	30524.89	34.970
30006.01	34.465	30006.19	34.465	30524.89	34.990
30006.01	34.465	30006.19	34.425	30524.89	34.970
30006.01	34.445	30006.19	34.445	30524.89	34.930
30006.01	34.445	30006.19	34.445	30524.89	35.010
30006.01	34.445	30006.19	34.425	30524.89	34.930
30006.01	34.445	30006.19	34.425	30524.89	34.950
30006.01	34.465	30006.19	34.425	30524.89	34.950
30006.01	34.465	30006.19	34.445	30524.89	34.930
30006.01	34.465	30006.19	34.405	30524.89	34.950
30006.01	34.405	30006.19	34.445	30524.89	34.950
30006.01	34.445	30006.19	34.465	30524.89	34.990
30006.01	34.465	30006.19	34.445	30524.89	35.010
30006.01	34.425	30006.19	34.385	30524.89	34.950
39994.27	44.385	39994.04	44.445	0.00	4.513
39994.27	44.365	39994.04	44.405	0.00	4.513

Table A.1 Data Set 1 - Relative Distance Calibration: 0 m to 60 m

Location: Environmentally controlled lab, Bldg. 220 No Filter File: rel_dist_anal.xls Test dates: July 14-15, 1999				Location: Environmentally controlled lab, Bldg. 220 No Filter File: 8_22_99_laser.xls Test date: Aug. 2, 1999	
Interfero. Dist. (mm)	Yllw, not shiny (m)	Interfero. Dist. (mm)	Grn, not shiny (m)	Interfero. Dist. (mm)	Grn, not shiny – recal. (m)
39994.27	44.405	39994.04	44.425	0.00	4.493
39994.27	44.405	39994.04	44.445	0.00	4.513
39994.27	44.405	39994.04	44.465	0.00	4.473
39994.27	44.365	39994.04	44.405	0.00	4.493
39994.27	44.405	39994.04	44.465	0.00	4.473
39994.27	44.405	39994.04	44.465	0.00	4.493
39994.27	44.425	39994.04	44.405	0.00	4.493
39994.27	44.405	39994.04	44.445	0.00	4.493
39994.27	44.385	39994.04	44.465	0.00	4.513
39994.27	44.365	39994.04	44.425	0.00	4.493
39994.27	44.405	39994.04	44.445	0.00	4.513
39994.27	44.435	39994.04	44.405	0.00	4.513
39994.27	44.405	39994.04	44.405	0.00	4.493
39994.27	44.365	39994.04	44.445	0.00	4.493
39994.27	44.405	39994.04	44.445	0.00	4.493
39994.27	44.405	39994.04	44.405	0.00	4.493
39994.27	44.465	39994.04	44.405	0.00	4.493
39994.27	44.485	39994.04	44.385	0.00	4.493
39994.27	44.405	39994.04	44.385	0.00	4.493
39994.27	44.405	39994.04	44.465	0.00	4.493
39994.27	44.385	39994.04	44.425	0.00	4.513
39994.27	44.385	39994.04	44.445	0.00	4.493
39994.27	44.405	39994.04	44.405	0.00	4.513
49952.25	54.325	49988.89	54.445	40112.49	44.570
49952.25	54.305	49988.89	54.465	40112.49	44.585
49952.25	54.305	49988.89	54.465	40112.49	44.525
49952.25	54.325	49988.89	54.485	40112.49	44.585
49952.25	54.365	49988.89	54.405	40112.49	44.585
49952.25	54.325	49988.89	54.505	40112.49	44.550
49952.25	54.405	49988.89	54.385	40112.49	44.565
49952.25	54.285	49988.89	54.465	40112.49	44.605
49952.25	54.305	49988.89	54.425	40112.49	44.565
49952.25	54.285	49988.89	54.425	40112.49	44.565
49952.25	54.305	49988.89	54.485	40112.49	44.585
49952.25	54.365	49988.89	54.485	40112.49	44.585
49952.25	54.305	49988.89	54.465	40112.49	44.585
49952.25	54.325	49988.89	54.465	40112.49	44.605
49952.25	54.285	49988.89	54.465	40112.49	44.570
49952.25	54.325	49988.89	54.405	40112.49	44.605
49952.25	54.385	49988.89	54.505	40112.49	44.590
49952.25	54.305	49988.89	54.445	40112.49	44.625
49952.25	54.325	49988.89	54.465	40112.49	44.565
49952.25	54.305	49988.89	54.505	40112.49	44.610
49952.25	54.305	49988.89	54.445	40112.49	44.565
49952.25	54.325	49988.89	54.465	40112.49	44.630
49952.25	54.325	49988.89	54.445	40112.49	44.590
49952.25	54.345	49988.89	54.425	40112.49	44.585
49952.25	54.305	49988.89	54.425	40112.49	44.625
				49066.14	53.585
				49066.14	53.585
				49066.14	53.565
				49066.14	53.545
				49066.14	53.505
				49066.14	53.585
				49066.14	53.545
				49066.14	53.565
				49066.14	53.605

Table A.1 Data Set 1 - Relative Distance Calibration: 0 m to 60 m

Location: Environmentally controlled lab, Bldg. 220 No Filter File: rel_dist_anal.xls Test dates: July 14-15, 1999				Location: Environmentally controlled lab, Bldg. 220 No Filter File: 8_22_99_laser.xls Test date: Aug. 2, 1999	
Interfero. Dist. (mm)	Yllw, not shiny (m)	Interfero. Dist. (mm)	Grn, not shiny (m)	Interfero. Dist. (mm)	Grn, not shiny – recal. (m)
				49066.14	53.605
				49066.14	53.545
				49066.14	53.645
				49066.14	53.565
				49066.14	53.605
				49066.14	53.625
				49066.14	53.625
				49066.14	53.565
				49066.14	53.565
				49066.14	53.545
				49066.14	53.565
				49066.14	53.565
				49066.14	53.545
				49066.14	53.565
				49066.14	53.565
				49066.14	53.525

APPENDIX B – Absolute Distance Measurements

Table B.1 Data Set 2 - Absolute Distance Calibration, 30 m and 60 m

Location: Environmentally controlled lab, Bldg. 220			File: abs_dist.xls	
No Filter				
Test date: July 22, 1999				
Distance (m)	Laser (m) Run 1	Laser (m) Run 2	Distance (m)	Laser (m)
30.48	30.430	30.474	60.96	61.005
30.48	30.430	30.474	60.96	60.985
30.48	30.450	30.454	60.96	61.045
30.48	30.470	30.490	60.96	61.045
30.48	30.450	30.474	60.96	61.025
30.48	30.470	30.474	60.96	60.985
30.48	30.430	30.450	60.96	61.065
30.48	30.430	30.470	60.96	61.045
30.48	30.470	30.470	60.96	61.045
30.48	30.490	30.454	60.96	61.025
30.48	30.470	30.470	60.96	61.045
30.48	30.450	30.470	60.96	61.025
30.48	30.470	30.494	60.96	61.025
30.48	30.470	30.450	60.96	60.985
30.48	30.470	30.470	60.96	61.045
30.48	30.470	30.490	60.96	61.025
30.48	30.490	30.434	60.96	61.065
30.48	30.450	30.450	60.96	61.045
30.48	30.470	30.470	60.96	61.045
30.48	30.470	30.450	60.96	61.005
30.48	30.470	30.470	60.96	61.045
30.48	30.470	30.454	60.96	60.985
30.48	30.470	30.454	60.96	61.005
30.48	30.470	30.470	60.96	61.045
30.48	30.410	30.470	60.96	61.025

Table B.2 Data Set 3 - Absolute Distance Calibration, 60 m to 108 m

Location: Attic, Bldg. 226		Location: Attic, Bldg. 226	
No Filter		No Filter	
File: 100mcalib.xls		File: 108m_calib.xls	
Test Date: July 28, 1999		Test Date: August 2, 1999	
Tape Distance (m)	Wht, not shiny (m)	Tape Distance (m)	Wht., not shiny (m)
60	60.066	108.00	108.019
60	59.986	108.00	108.019
60	60.066	108.00	108.054
60	60.046	108.00	108.054
60	60.026	108.00	108.039
60	60.026	108.00	108.014
60	60.026	108.00	108.014
60	60.046	108.00	108.034
60	60.046	108.00	108.074
60	60.006	108.00	108.054
60	60.046	108.00	108.034
60	60.066	108.00	108.014
60	60.026	108.00	108.014
60	60.066	108.00	108.034
60	60.046	108.00	108.034
60	60.026	108.00	108.034

Table B.2 Data Set 3 - Absolute Distance Calibration, 60 m to 108 m

Location: Attic, Bldg. 226 No Filter File: 100mcalib.xls Test Date: July 28, 1999		Location: Attic, Bldg. 226 No Filter File: 108m_calib.xls Test Date: August 2, 1999	
Tape Distance (m)	Wht, not shiny (m)	Tape Distance (m)	Wht., not shiny (m)
60	60.046	108.00	108.054
60	60.046	108.00	108.074
60	60.026	108.00	108.034
60	60.022	108.00	108.014
60	60.022	108.00	108.074
60	60.022	108.00	108.014
60	60.042	108.00	108.054
60	60.022	108.00	108.054
60	60.046	108.00	108.034
80	79.982	100.00	99.954
80	80.002	100.00	100.010
80	80.002	100.00	99.970
80	80.002	100.00	100.030
80	80.022	100.00	100.010
80	80.062	100.00	100.010
80	80.002	100.00	99.990
80	80.062	100.00	99.970
80	80.022	100.00	99.950
80	80.042	100.00	99.970
80	80.042	100.00	100.005
80	80.042	100.00	99.985
80	80.042	100.00	99.965
80	80.082	100.00	100.005
80	80.042	100.00	100.005
80	80.062	100.00	99.985
80	80.062	100.00	100.025
80	80.022	100.00	100.005
80	79.982	100.00	100.025
80	80.042	100.00	100.025
80	80.042	100.00	100.005
80	80.042	100.00	99.985
80	80.022	100.00	99.945
80	80.082	100.00	100.005
80	80.062	100.00	99.985
100	100.062		
100	100.122		
100	100.182		
100	100.162		
100	100.162		
100	100.182		
100	100.102		
100	100.142		
100	100.062		
100	100.162		
100	100.162		
100	100.102		
100	100.102		
100	100.162		
100	100.162		
100	100.142		
100	100.142		
100	100.122		
100	100.102		

Table B.2 Data Set 3 - Absolute Distance Calibration, 60 m to 108 m

Location: Attic, Bldg. 226 No Filter File: 100mcalib.xls Test Date: July 28, 1999		Location: Attic, Bldg. 226 No Filter File: 108m_calib.xls Test Date: August 2, 1999	
Tape Distance (m)	Wht, not shiny (m)	Tape Distance (m)	Wht., not shiny (m)
100	100.082		
100	100.182		
100	100.062		
100	100.122		
100	100.102		
100	100.142		
108 [†]	109.182		
108	109.182		
108	109.177		
108	109.157		
108	109.157		
108	109.197		
108	109.137		
108	109.217		
108	109.157		
108	109.197		
108	109.157		
108	109.177		
108	109.157		
108	109.197		
108	109.197		
108	109.177		
108	109.177		
108	109.177		
108	109.137		
108	109.117		
108	109.197		
108	109.197		
108	109.137		
108	109.117		
108	109.137		

Note:
[†] Laser hit wall behind target. Data disregarded.

Table B.3 Data Set 4 - Absolute Distance Calibration: 5 m to 161 m

Location: Hallway from Bldg. 226 to Comstar			Black and Green Targets -File: 5mto160m_8_10_99.xls			
Test date: August 6, 1999 – white target			White Target – File: 5to160m_8_6_99.xls			
August 10, 1999 – green and black targets						
Distance (m)	Without Filter		Distance (m)	With Filter		
	Blk not shny (m)	Grn not shny (m)		Blk, not shny (m)	Grn. not shny (m)	Wht not shny (m)
161.079	161.039	161.104	161.0790	NA	NA	161.134
161.079	161.159	161.204	161.0790	NA	NA	161.474
161.079	161.159	161.104	161.0790	NA	NA	161.094
161.079	160.979	161.004	161.0790	NA	NA	161.074
161.079	161.019	161.304	161.0790	NA	NA	161.034
161.079	161.019	161.184	161.0790	NA	NA	162.034
161.079	161.199	161.204	161.0790	NA	NA	161.854
161.079	161.139	161.124	161.0790	NA	NA	161.594
161.079	160.999	161.244	161.0790	NA	NA	161.794
161.079	161.099	161.244	161.0790	NA	NA	161.150
141.059	141.145	140.990	151.071	151.219	151.179	151.130
141.059	141.085	140.945	151.071	151.159	151.239	151.110
141.059	141.045	140.985	151.071	151.419	151.059	151.150
141.059	141.085	140.965	151.071	151.039	151.239	151.110
141.059	141.105	140.945	151.071	151.419	151.159	151.030
141.059	141.125	140.985	151.071	151.299	151.199	151.070
141.059	141.110	141.045	151.071	151.219	151.099	151.150
141.059	141.210	141.085	151.071	151.559	151.179	151.110
141.059	141.105	141.045	151.071	151.259	151.259	151.070
141.059	141.170	141.025	151.071	151.219	151.074	151.150
120.000	120.065	119.965	141.059	141.294	141.054	141.070
120.000	120.105	119.965	141.059	141.094	141.149	141.085
120.000	120.105	119.985	141.059	141.174	140.994	141.165
120.000	120.065	119.965	141.059	141.294	141.114	141.085
120.000	120.045	119.945	141.059	141.394	141.114	141.065
120.000	120.105	119.965	141.059	141.294	141.174	141.085
120.000	120.065	119.965	141.059	141.194	141.074	141.085
120.000	120.125	119.965	141.059	141.294	141.154	141.045
120.000	120.065	120.165	141.059	141.234	141.034	141.105
120.000	120.025	119.985	141.059	141.334	141.434	141.165
79.990	80.010	80.070	129.989	130.074	129.234	130.045
79.990	79.970	80.025	129.989	129.994	129.934	130.045
79.990	80.025	80.010	129.989	129.974	130.014	130.025
79.990	80.010	80.025	129.989	130.114	130.014	129.985
79.990	80.030	80.050	129.989	129.974	129.974	130.005
79.990	80.010	80.025	129.989	130.054	130.014	130.045
79.990	80.030	80.025	129.989	129.934	130.054	130.085
79.990	79.990	80.070	129.989	129.994	130.074	129.965
79.990	80.005	80.045	129.989	129.994	129.954	130.045
79.990	79.990	80.010	129.989	129.874	130.094	130.045
60.596	60.565	60.630	120.000	119.994	120.054	120.000
60.596	60.585	60.625	120.000	120.030	120.050	120.020
60.596	60.545	60.605	120.000	120.094	120.054	120.000
60.596	60.565	60.625	120.000	119.950	120.054	120.040
60.596	60.585	60.665	120.000	120.010	120.030	120.020
60.596	60.525	60.605	120.000	120.014	120.114	120.000
60.596	60.505	60.625	120.000	119.990	120.054	119.980
60.596	60.545	60.605	120.000	120.070	120.014	120.000
60.596	60.585	60.625	120.000	120.110	120.014	120.040
60.596	60.565	60.625	120.000	119.950	120.034	120.040
50.425	50.405	50.445	120.000	NA	NA	120.080
50.425	50.425	50.445	120.000	NA	NA	120.040
50.425	50.425	50.425	120.000	NA	NA	120.020
50.425	50.425	50.445	120.000	NA	NA	120.040
50.425	50.425	50.465	120.000	NA	NA	120.020
50.425	50.385	50.425	120.000	NA	NA	120.040
50.425	50.425	50.425	120.000	NA	NA	120.040
50.425	50.405	50.425	120.000	NA	NA	120.020
50.425	50.425	50.445	120.000	NA	NA	119.980

Table B.3 Data Set 4 - Absolute Distance Calibration: 5 m to 161 m

Location: Hallway from Bldg. 226 to Comstar			Black and Green Targets -File: 5mto160m_8_10_99.xls			
Test date: August 6, 1999 – white target			White Target – File: 5to160m_8_6_99.xls			
August 10, 1999 – green and black targets						
Distance (m)	Without Filter		Distance (m)	With Filter		
	Blk not shny (m)	Grn not shny (m)		Blk, not shny (m)	Grn. not shny (m)	Wht not shny (m)
50.425	50.425	50.425	120.000	NA	NA	120.020
39.998	40.005	39.985	109.990	110.090	109.950	110.020
39.998	40.045	40.025	109.990	109.990	110.050	110.060
39.998	40.020	40.025	109.990	110.070	110.050	110.060
39.998	40.060	40.025	109.990	110.010	109.990	110.040
39.998	40.020	40.025	109.990	109.970	110.050	110.020
39.998	40.000	40.025	109.990	109.990	110.070	110.020
39.998	40.060	40.025	109.990	110.090	109.970	110.040
39.998	40.020	40.025	109.990	110.050	110.030	110.080
39.998	40.000	40.025	109.990	110.050	110.030	110.040
39.998	40.000	40.045	109.990	109.990	110.030	110.080
30.097	30.140	30.120	99.993	99.990	100.010	100.056
30.097	30.140	30.100	99.993	100.010	100.030	100.056
30.097	30.120	30.120	99.993	100.010	99.970	100.056
30.097	30.140	30.120	99.993	100.030	100.010	100.076
30.097	30.180	30.120	99.993	100.050	100.030	100.056
30.097	30.140	30.120	99.993	100.050	100.010	100.096
30.097	30.140	30.140	99.993	100.030	99.970	100.016
30.097	30.120	30.140	99.993	100.070	100.010	100.076
30.097	30.160	30.120	99.993	100.010	100.030	100.076
30.097	30.140	30.120	99.993	100.010	100.010	100.076
19.975	20.020	19.985	79.990	80.025	80.005	80.011
19.975	20.040	19.985	79.990	79.945	80.005	80.031
19.975	20.020	20.005	79.990	80.050	80.005	79.991
19.975	20.005	19.965	79.990	80.010	80.050	80.011
19.975	20.045	20.005	79.990	80.005	79.970	80.031
19.975	19.985	19.985	79.990	80.030	79.985	80.011
19.975	20.045	20.005	79.990	80.090	80.010	80.011
19.975	20.045	20.005	79.990	79.970	80.010	79.991
19.975	20.020	19.985	79.990	79.970	79.985	80.011
19.975	20.045	19.985	79.990	80.050	79.965	80.051
10.002	10.047	10.031	60.596	60.605	60.585	60.631
10.002	10.067	10.011	60.596	60.605	60.585	60.611
10.002	10.027	9.991	60.596	60.665	60.605	60.611
10.002	10.067	10.031	60.596	60.645	60.550	60.551
10.002	10.067	10.011	60.596	60.665	60.605	60.591
10.002	10.047	10.031	60.596	60.665	60.605	60.611
10.002	10.007	10.031	60.596	60.625	60.585	60.611
10.002	10.047	10.011	60.596	60.645	60.545	60.651
10.002	10.047	10.031	60.596	60.625	60.565	60.611
10.002	10.067	10.031	60.596	60.645	60.585	60.611
5.009	5.040	5.000	50.425	50.485	50.445	50.471
5.009	5.040	5.000	50.425	50.485	50.465	50.471
5.009	5.040	5.020	50.425	50.465	50.425	50.451
5.009	5.060	5.004	50.425	50.425	50.465	50.471
5.009	5.040	5.040	50.425	50.465	50.425	50.431
5.009	5.020	5.000	50.425	50.385	50.465	50.451
5.009	5.020	5.000	50.425	50.445	50.445	50.471
5.009	5.040	5.020	50.425	50.425	50.465	50.451
5.009	5.040	4.979	50.425	50.485	50.465	50.471
5.009	5.040	5.020	50.425	50.465	50.465	50.491
			39.998	40.025	40.045	40.031
			39.998	40.025	40.045	40.031
			39.998	40.045	40.045	40.051
			39.998	40.005	40.025	40.031
			39.998	40.025	40.025	40.031
			39.998	40.025	40.045	40.011
			39.998	40.045	40.045	40.031
			39.998	40.060	40.045	40.051
			39.998	40.025	40.040	40.011
			39.998	40.045	40.045	40.051

Table B.3 Data Set 4 - Absolute Distance Calibration: 5 m to 161 m

Location: Hallway from Bldg. 226 to Comstar			Black and Green Targets -File: 5mto160m_8_10_99.xls			
Test date: August 6, 1999 – white target			White Target – File: 5to160m_8_6_99.xls			
August 10, 1999 – green and black targets						
Distance (m)	Without Filter		Distance (m)	With Filter		
	Blk not shny (m)	Grn not shny (m)		Blk, not shny (m)	Grn. not shny (m)	Wht not shny (m)
			30.097	30.100	30.140	30.151
			30.097	30.080	30.120	30.151
			30.097	30.120	30.160	30.151
			30.097	30.080	30.140	30.131
			30.097	30.060	30.120	30.131
			30.097	30.160	30.120	30.131
			30.097	30.140	30.140	30.171
			30.097	30.120	30.160	30.151
			30.097	30.120	30.160	30.171
			30.097	30.100	30.140	30.171
			19.975	19.985	20.025	19.991
			19.975	19.980	20.025	20.031
			19.975	19.980	20.025	19.971
			19.975	19.965	20.025	20.031
			19.975	19.985	20.025	20.011
			19.975	19.965	20.005	20.011
			19.975	19.965	20.025	20.011
			19.975	19.945	20.025	19.991
			19.975	19.985	19.985	20.031
			19.975	19.985	20.045	20.011
			10.002	9.966	10.051	10.010
			10.002	9.966	10.051	10.015
			10.002	9.966	10.051	10.035
			10.002	9.966	10.051	10.055
			10.002	10.007	10.051	10.035
			10.002	9.986	10.051	10.055
			10.002	9.986	10.051	10.015
			10.002	10.027	10.011	10.055
			10.002	10.007	10.011	10.050
			10.002	10.007	10.011	10.055
			5.009	4.959	5.040	5.026
			5.009	4.979	5.040	4.997
			5.009	4.959	5.020	4.997
			5.009	5.000	5.040	5.037
			5.009	4.979	5.040	5.017
			5.009	5.000	5.040	5.017
			5.009	5.000	5.000	5.012
			5.009	4.979	5.040	5.012
			5.009	4.959	5.040	4.971
			5.009	5.000	5.040	5.012

Table B.4 Data Set 5 - Absolute Distance Calibration: 10 m to 150 m

Location: Tunnel, Bldg. 101							File: calib_form_4_28_01.xls					
No Filter												
Test date: April 28, 2001												
Distance (m)	Black		White		Silver, shiny		3M Long Distance Performance (LDP)					
	Laser Dist (m)	Inten.	Laser Dist. (m)	Inten.	Laser Dist. (m)	Inten.	0°		45°		60°	
							Laser Dist. (m)	Inten.	Laser Dist. (m)	Inten.	Laser Dist. (m)	Inten.
9.997	10.023	80	10.007	156	9.977	206	10.173	228	10.009	208	10.044	182
9.997	9.957	80	9.986	156	9.972	206	10.169	236	9.968	208	10.024	182
9.997	10.018	80	10.007	156	9.952	206	10.109	226	9.983	208	9.963	182
9.997	9.957	80	9.946	156	9.912	206	10.129	228	9.983	208	10.024	182
9.997	9.998	80	9.966	156	9.972	206	10.109	226	9.983	208	10.044	182
9.997	9.998	80	9.942	156	10.013	204	10.149	230	10.004	208	9.983	182
9.997	9.998	80	9.982	156	9.972	206	10.169	230	9.943	208	10.024	182
9.997	9.977	80	10.023	156	9.972	206	10.109	224	10.004	208	10.024	182
9.997	9.988	80	10.003	156	9.932	204	10.189	230	9.963	208	10.024	182
9.997	10.018	80	9.982	156	9.972	204	10.129	228	9.943	208	10.044	182
19.991	20.024	82	19.999	152	19.999	206	20.153	230	20.084	190	20.144	162
19.991	19.984	82	19.999	152	19.939	206	20.108	224	20.064	190	20.164	162
19.991	20.004	84	19.959	152	19.959	206	20.164	232	20.064	190	20.124	162
19.991	19.984	82	19.959	152	19.939	206	20.124	226	20.064	190	20.164	162
19.991	20.004	84	19.939	152	19.979	206	20.124	224	20.064	190	20.104	162
19.991	20.004	82	19.979	152	19.959	206	20.104	224	20.064	190	20.184	162
19.991	20.004	82	19.999	152	19.959	206	20.144	230	20.084	190	20.124	162
19.991	20.004	82	19.979	152	19.979	206	20.164	234	20.064	190	20.164	162
19.991	19.964	82	19.959	152	19.959	206	20.144	230	20.064	190	20.124	160
19.991	20.004	82	19.979	152	19.979	206	20.144	232	20.084	190	20.164	162
29.986	29.914	70	29.954	140	29.954	192	30.074	232	29.974	202	30.014	172
29.986	29.934	70	29.934	140	29.974	192	30.094	224	29.954	200	29.970	172
29.986	29.914	70	29.934	140	29.974	192	30.094	228	29.954	200	29.974	172
29.986	29.894	70	29.974	140	29.934	192	30.054	224	29.934	202	29.970	172
29.986	29.954	70	29.974	140	29.974	192	30.094	224	29.930	202	29.990	172
29.986	29.914	70	29.974	140	29.974	192	30.074	226	29.914	200	29.990	172
29.986	29.934	70	29.974	140	29.974	192	30.074	228	29.954	202	29.950	172
29.986	29.934	70	29.934	140	29.974	192	30.094	232	29.914	202	29.990	172
29.986	29.934	70	29.974	140	29.954	192	30.054	224	29.934	200	29.994	172
29.986	29.934	70	29.994	140	29.954	192	30.094	224	29.934	200	29.990	172
39.988	39.95	62	39.97	124	39.97	192	40.03	226	39.970	196	40.010	164
39.988	39.97	60	39.99	124	39.93	192	40.03	226	39.950	196	39.965	164
39.988	39.93	60	40.01	124	39.99	192	40.05	224	39.950	196	39.970	164
39.988	39.97	62	40.01	124	39.93	192	40.05	224	39.950	196	40.010	164
39.988	39.95	62	39.99	124	39.99	192	40.03	226	39.970	196	39.970	164
39.988	39.95	60	39.99	124	39.97	192	40.03	228	39.950	196	40.010	164
39.988	39.99	60	40.01	124	39.95	192	40.05	222	39.970	196	39.990	164
39.988	39.93	60	39.99	124	39.99	194	40.03	226	39.930	196	39.990	164
39.988	39.93	60	39.99	124	39.93	192	40.05	226	39.970	196	40.005	164
39.988	39.95	60	40.01	124	39.93	192	40.03	222	39.970	196	39.950	164
49.981	49.99	52	49.965	112	49.945	188	50.01	222	49.925	190	49.945	130
49.981	49.965	52	49.965	112	49.985	188	49.985	222	49.945	190	49.965	130
49.981	49.985	52	49.985	112	49.965	188	50.005	222	49.945	190	49.945	130
49.981	49.985	52	50.005	112	49.925	188	50.005	222	49.945	190	49.950	130
49.981	49.925	54	50.005	112	49.985	188	50.005	222	49.945	190	49.905	130
49.981	50.005	54	49.965	112	49.985	188	49.965	222	49.905	190	49.945	130
49.981	49.985	54	49.965	112	49.985	188	50.005	222	49.945	190	49.945	130
49.981	50.025	54	50.005	112	49.945	188	50.005	222	49.905	190	49.945	130
49.981	49.985	52	49.965	112	49.985	188	49.965	222	49.945	190	49.945	130
49.981	49.985	52	50.005	112	49.945	188	49.985	222	49.925	190	49.905	130
59.977	59.99	48	59.97	102	59.97	182	59.99	218	59.865	186	59.925	146
59.977	60.05	48	60.01	102	59.97	182	59.985	220	59.885	186	59.905	146
59.977	60.01	48	59.99	102	59.95	182	59.985	218	59.905	188	59.865	146
59.977	59.95	48	59.99	102	59.99	182	59.985	218	59.905	186	59.905	146
59.977	59.99	48	59.95	102	59.97	182	59.965	218	59.865	186	59.905	146
59.977	60.01	48	60.01	102	59.93	182	59.925	218	59.905	186	59.925	146
59.977	59.95	46	60.03	102	59.97	182	59.945	218	59.905	186	59.885	146

Table B.4 Data Set 5 - Absolute Distance Calibration: 10 m to 150 m

Location: Tunnel, Bldg. 101							File: calib_form_4_28_01.xls					
No Filter												
Test date: April 28, 2001												
Distance (m)	Black		White		Silver, shiny		3M Long Distance Performance (LDP)					
	Laser Dist (m)	Inten.	Laser Dist. (m)	Inten.	Laser Dist. (m)	Inten.	0°		45°		60°	
							Laser Dist. (m)	Inten.	Laser Dist. (m)	Inten.	Laser Dist. (m)	Inten.
59.977	59.99	48	60.01	102	59.97	182	59.985	220	59.905	186	59.865	146
59.977	59.99	48	59.99	102	59.97	182	59.965	218	59.905	186	59.905	146
59.977	59.99	48	59.97	102	59.97	182	59.985	218	59.905	186	59.905	146
69.971	69.985	42	69.985	94	69.945	178	69.965	216	69.945	186	69.925	140
69.971	69.985	42	69.965	94	69.985	178	69.925	216	69.945	186	69.885	138
69.971	70.005	42	69.965	94	69.965	178	69.985	216	69.945	186	69.945	140
69.971	69.985	42	69.985	94	69.965	178	69.965	216	69.925	186	69.945	140
69.971	69.985	42	69.985	94	69.965	178	69.925	216	69.945	186	69.925	140
69.971	69.985	42	69.965	94	69.925	178	69.965	216	69.945	186	69.925	138
69.971	70.025	42	69.965	94	69.945	178	69.965	216	69.945	186	69.885	140
69.971	69.945	42	69.985	94	69.965	178	69.985	216	69.905	186	69.905	140
69.971	69.945	44	70.005	94	69.965	178	69.965	216	69.925	184	69.905	140
69.971	69.985	42	69.985	94	69.965	178	69.945	216	69.905	186	69.925	140
79.967	79.985	40	79.965	86	79.965	182	79.965	214	79.865	184	79.925	120
79.967	80.025	38	79.965	86	79.965	184	79.945	214	79.845	184	79.885	120
79.967	79.925	40	79.985	88	79.885	182	79.945	214	79.845	184	79.905	122
79.967	80.005	40	79.985	86	79.945	182	79.965	214	79.885	184	79.945	122
79.967	79.945	40	79.965	86	79.965	184	79.965	214	79.885	184	79.945	120
79.967	79.965	40	80.025	88	79.965	182	79.905	214	79.905	184	79.925	120
79.967	80.005	38	80.025	88	79.905	182	79.965	214	79.845	184	79.925	122
79.967	79.965	40	79.965	86	79.965	182	79.945	214	79.865	184	79.945	122
79.967	79.985	38	79.965	86	79.945	182	79.965	214	79.865	184	79.885	120
79.967	80.025	40	79.985	88	79.945	182	79.985	214	79.905	184	79.945	122
89.961	89.973	38	89.982	84	89.942	184	89.893	212	89.868	184	89.928	112
89.961	89.938	38	89.958	84	89.922	182	89.893	214	89.828	184	89.988	112
89.961	89.993	38	89.938	84	89.962	182	89.888	214	89.828	184	89.968	112
89.961	89.953	38	89.998	84	89.942	182	89.933	214	89.868	184	89.968	112
89.961	89.933	38	89.978	84	89.902	182	89.933	214	89.888	184	89.968	112
89.961	89.973	40	89.958	84	89.942	182	89.908	214	89.868	184	89.968	112
89.961	89.953	38	89.978	84	89.922	184	89.933	214	89.868	184	89.968	112
89.961	89.973	38	89.978	84	89.942	182	89.948	214	89.848	184	89.968	112
89.961	89.993	38	89.978	84	89.942	184	89.948	214	89.828	184	89.968	112
89.961	89.953	38	89.958	84	89.902	184	89.888	214	89.868	184	89.988	112
99.955	99.964	34	99.919	78	99.944	184	99.928	210	99.864	182	99.964	102
99.955	99.984	34	99.979	78	99.939	184	99.924	210	99.864	182	99.964	102
99.955	99.944	36	99.959	78	99.939	184	99.884	210	99.864	182	99.924	102
99.955	99.964	36	99.959	78	99.959	184	99.924	212	99.864	182	99.984	102
99.955	100.004	36	99.959	78	99.919	184	99.884	210	99.844	182	99.984	102
99.955	99.964	36	99.919	78	99.939	184	99.904	210	99.864	182	99.964	102
99.955	99.924	36	99.959	80	99.959	184	99.944	210	99.864	182	99.964	102
99.955	100.004	36	99.959	78	99.939	184	99.944	210	99.864	182	99.964	102
99.955	100.044	36	99.959	78	99.939	184	99.924	210	99.864	182	99.984	102
99.955	99.984	36	99.959	78	99.899	184	99.884	210	99.824	182	99.944	102
109.949	109.959	34	109.939	74	109.954	176	109.914	208	109.854	180	109.914	98
109.949	109.879	34	109.934	74	109.874	174	109.984	208	109.854	180	109.934	98
109.949	109.979	34	109.934	76	109.914	174	109.934	208	109.874	180	109.954	98
109.949	109.914	34	109.934	76	109.954	174	109.914	208	109.834	180	109.954	98
109.949	109.919	34	109.934	74	109.894	176	109.934	208	109.854	180	109.954	98
109.949	109.854	34	109.934	76	109.934	174	109.914	208	109.874	180	109.974	98
109.949	109.959	34	109.894	74	109.934	174	109.934	208	109.814	180	109.974	98
109.949	109.954	34	109.954	74	109.894	174	109.934	208	109.854	180	109.954	98
109.949	109.959	34	109.934	76	109.914	176	109.934	208	109.874	180	109.974	98
109.949	109.974	34	109.914	74	109.934	174	109.914	208	109.874	180	109.954	98
119.944	119.93	34	119.914	72	119.934	170	119.914	206	119.874	170	119.934	88
119.944	119.99	34	119.874	72	119.934	174	119.934	206	119.894	170	119.954	88
119.944	119.95	34	119.93	72	119.934	168	119.934	206	119.874	172	119.934	88
119.944	119.87	34	119.93	72	119.934	170	119.934	206	119.954	170	119.954	88
119.944	119.93	34	119.89	72	119.914	168	119.934	206	119.984	170	119.914	88

Table B.4 Data Set 5 - Absolute Distance Calibration: 10 m to 150 m

Location: Tunnel, Bldg. 101							File: calib_form_4_28_01.xls					
No Filter												
Test date: April 28, 2001												
Distance (m)	Black		White		Silver, shiny		3M Long Distance Performance (LDP)					
							0°		45°		60°	
	Laser Dist (m)	Inten.	Laser Dist. (m)	Inten.	Laser Dist. (m)	Inten.	Laser Dist. (m)	Inten.	Laser Dist. (m)	Inten.	Laser Dist. (m)	Inten.
119.944	119.97	34	119.91	72	119.934	168	119.914	206	119.894	170	119.914	88
119.944	119.93	34	119.91	72	119.93	168	119.934	206	119.894	170	119.954	88
119.944	119.99	34	119.93	72	119.95	168	119.934	206	119.894	170	119.950	88
119.944	119.91	34	119.87	72	119.914	168	119.914	206	119.874	172	119.934	88
119.944	119.89	34	119.874	72	119.95	168	119.894	206	119.854	170	119.954	88
129.941	129.91	36	129.91	68	129.93	166	129.91	204	129.910	162	129.890	80
129.941	129.91	36	129.89	68	129.91	166	129.91	204	129.930	162	129.890	80
129.941	129.97	36	129.89	68	129.95	166	129.89	204	129.910	162	129.910	80
129.941	129.93	36	129.91	68	129.89	166	129.87	204	129.910	162	129.910	80
129.941	129.93	36	129.91	68	129.95	166	129.93	204	129.910	162	129.910	80
129.941	129.95	36	129.89	68	129.93	166	129.93	204	129.950	162	129.910	80
129.941	129.95	36	129.93	68	129.93	164	129.93	204	129.910	162	129.870	80
129.941	129.95	36	129.91	68	129.91	166	129.93	204	129.890	162	129.930	80
129.941	129.87	36	129.87	68	129.91	166	129.93	204	129.930	162	129.890	80
129.941	129.91	36	129.91	68	129.91	166	129.91	204	129.890	162	129.910	80
139.939	140.048	44	139.928	68	139.924	156	139.898	204	139.873	154	139.968	82
139.939	139.968	46	139.884	68	139.884	158	139.893	204	139.873	154	139.908	82
139.939	139.988	44	139.864	68	139.944	162	139.913	204	139.873	154	139.928	82
139.939	140.008	44	139.904	68	139.944	162	139.893	204	139.893	154	139.928	82
139.939	139.928	44	139.904	68	139.944	162	139.893	204	139.873	154	139.928	82
139.939	139.968	46	139.904	68	139.944	164	139.913	204	139.893	154	139.928	82
139.939	140.028	44	139.904	68	139.944	162	139.933	204	139.933	154	139.908	82
139.939	139.968	44	139.904	68	139.944	164	139.893	204	139.913	154	139.928	82
139.939	139.988	44	139.864	68	139.944	162	139.893	204	139.893	154	139.908	82
139.939	139.928	44	139.904	68	139.944	162	139.913	204	139.893	154	139.948	82
149.930	149.87	64	149.79	76	149.91	152	149.89	200	149.91	152	150.070	92
149.930	149.89	64	149.83	76	149.91	152	149.89	200	149.89	152	150.110	92
149.930	149.93	62	149.81	76	149.87	152	149.89	200	149.89	152	150.090	92
149.930	149.89	64	149.77	76	149.87	152	149.91	200	149.89	152	150.070	92
149.930	149.85	62	149.81	76	149.91	152	149.89	200	149.91	152	150.070	92
149.930	149.89	64	149.81	76	149.89	152	149.89	200	149.91	152	150.070	92
149.930	149.85	64	149.81	76	149.89	152	149.87	200	149.89	152	150.090	92
149.930	149.83	64	149.79	76	149.93	152	149.89	200	149.91	152	150.070	92
149.930	149.95	62	149.77	76	149.89	158	149.85	200	149.97	152	150.090	92
149.930	149.87	62	149.85	76	149.91	152	149.85	200	149.91	152	150.050	92
149.930	149.95	62	149.81	76	149.91	158	149.89	200	149.87	152	150.090	92

Table B.5 Data Set 6 - Angle of Laser Incidence: 10 m to 100 m

Attic, Bldg. 226												
No Filter												
Test Dates: Nov. 1, 5, and 28, 2001												
Silver, shiny												
Rotation Angle (°)												
Distance	0		10		20		30		40		50	
	(m)	Dist. (m)	Inten.	Dist. (m)	Inten.	Dist. (m)	Inten.	Dist. (m)	Inten.	Dist. (m)	Inten.	Dist. (m)
10	9.947	200	9.987	170	10.028	126	10.128	98	10.268	84	10.688	86
10	9.987	200	10.008	170	10.028	126	10.068	98	10.268	86	10.668	86
10	9.987	200	10.008	170	10.028	126	10.068	98	10.248	84	10.668	86
10	9.927	200	9.947	170	10.028	126	10.068	98	10.288	86	10.668	86
10	9.947	200	9.947	170	9.987	126	10.108	98	10.268	84	10.688	86
10	9.947	200	10.008	170	9.987	126	10.068	98	10.248	86	10.668	86
10	9.987	200	9.987	170	10.028	126	10.108	98	10.228	84	10.668	86
10	9.967	200	10.008	170	10.028	126	10.088	98	10.248	86	10.648	86
10	9.987	200	10.008	170	10.028	126	10.088	98	10.288	84	10.628	86
10	10.008	200	9.987	170	9.987	126	10.108	98	10.288	84	10.688	86
20	19.962	200	20.002	176	19.982	132	20.022	98	19.982	80	19.862	72
20	19.982	200	20.002	176	19.982	132	20.062	98	19.982	80	19.842	72
20	19.982	200	19.982	176	19.962	130	20.022	98	20.002	80	19.842	72
20	19.922	200	20.002	176	19.962	132	20.062	98	20.022	80	19.902	72
20	19.962	200	20.002	176	20.002	130	20.002	98	20.022	80	19.842	72
20	19.982	202	20.002	176	19.982	132	20.042	98	20.042	80	19.822	74
20	19.982	200	19.982	176	20.002	130	20.022	98	20.022	80	19.822	74
20	19.982	200	20.002	176	19.982	130	20.062	98	20.002	80	19.842	74
20	19.982	200	19.962	176	20.002	132	20.002	98	20.002	80	19.802	74
20	19.922	200	19.982	176	20.022	132	20.042	98	20.022	80	19.862	72
30	29.96	190	29.96	150	30.06	106	30.06	80	30.38	78	30.6	76
30	29.98	190	29.98	148	30.04	106	30.08	80	30.4	78	30.48	66
30	29.96	190	29.98	150	30.06	106	30.12	80	30.42	78	30.34	58
30	29.98	190	29.94	150	30.04	106	30.08	80	30.42	78	30.36	60
30	29.98	190	29.94	150	30.06	106	30.1	80	30.42	78	30.36	58
30	29.98	190	29.98	150	30.02	106	30.1	80	30.4	78	30.36	58
30	29.96	190	29.98	150	30.06	106	30.1	80	30.38	78	30.34	58
30	29.96	190	29.94	150	30.06	106	30.12	80	30.44	78	30.32	58
30	29.92	190	29.98	150	30.06	106	30.08	80	30.52	78	30.34	58
30	29.94	190	29.98	150	30.06	106	30.08	80	30.52	80	30.36	58
40	39.94	192	39.98	148	39.996	96	39.916	72	40.556	80	41.016	58
40	39.98	190	39.976	148	39.976	96	39.916	72	40.416	68	41.076	58
40	39.94	190	39.936	148	39.996	96	39.956	72	39.936	60	41.016	58
40	39.94	190	39.976	148	39.996	96	39.936	72	39.956	60	40.976	58
40	39.96	192	39.956	148	40.016	96	39.956	72	39.996	62	41.076	58
40	39.96	190	39.996	148	39.976	96	39.916	72	39.936	62	41.016	58
40	39.94	190	39.976	148	39.976	94	39.916	72	39.976	62	41.056	58
40	39.94	192	39.936	148	39.976	94	39.956	72	39.936	62	40.616	62
40	39.94	190	39.976	148	40.016	96	39.916	72	39.976	62	40.996	58
40	39.94	192	39.956	148	39.996	94	39.956	72	39.956	62	40.996	58
50	49.922	184	50.002	142	50.042	96	50.302	72	50.622	62	51.102	64
50	49.962	184	49.962	140	50.022	94	50.322	72	50.662	62	51.102	64
50	49.942	184	49.982	140	50.022	94	50.262	72	50.662	62	51.102	66
50	49.942	184	49.942	140	50.042	94	50.322	72	50.662	62	51.062	66
50	49.922	184	49.962	140	50.042	94	50.302	72	50.642	62	51.062	66
50	49.942	184	49.962	140	50.042	94	50.302	72	50.622	62	51.082	64
50	49.942	184	49.982	140	50.042	96	50.262	72	50.642	62	51.062	64
50	49.942	184	49.962	140	50.022	94	50.282	72	50.642	62	51.042	66
50	49.942	184	49.982	140	50.022	94	50.302	72	50.622	62	51.082	66
50	49.942	184	49.982	140	50.022	94	50.322	72	50.662	62	51.062	66
60	59.968	184	59.984	134	60.019	84	60.094	62	60.47	60	60.685	70
60	59.908	184	59.959	136	60.034	84	60.05	62	60.49	60	60.725	70
60	59.908	184	59.919	134	59.994	84	60.09	62	60.49	60	60.745	70
60	59.948	184	59.939	136	60.014	84	60.07	64	60.485	60	60.725	70
60	59.928	184	59.919	136	60.034	84	60.11	62	60.51	60	60.745	70
60	59.988	184	59.919	136	59.994	84	60.09	64	60.53	60	60.745	68

Table B.5 Data Set 6 - Angle of Laser Incidence: 10 m to 100 m

Attic, Bldg. 226												
No Filter												
Test Dates: Nov. 1, 5, and 28, 2001												
Silver, shiny												
Rotation Angle (°)												
Distance (m)	0		10		20		30		40		50	
	Dist. (m)	Inten.	Dist. (m)	Inten.	Dist. (m)	Inten.	Dist. (m)	Inten.	Dist. (m)	Inten.	Dist. (m)	Inten.
60	59.964	184	59.979	134	60.034	84	60.09	62	60.49	60	60.765	68
60	59.944	184	59.939	134	60.034	82	60.07	62	60.51	60	60.765	68
60	59.944	184	59.919	134	60.034	84	60.09	62	60.485	60	60.725	68
60	59.904	184	59.919	134	60.034	84	60.07	64	60.49	60	60.765	68
70	69.922	182	69.982	112	70.042	68	70.282	52	70.962	52	71.082	48
70	69.962	182	70.002	112	70.022	70	70.222	52	71.062	52	71.082	48
70	69.942	182	70.002	112	70.002	68	70.282	52	70.922	52	71.082	48
70	69.942	182	70.002	112	70.022	70	70.262	52	70.962	52	71.082	48
70	69.942	182	70.002	112	70.022	70	70.282	52	71.002	52	71.062	48
70	69.942	182	69.982	112	69.982	70	70.282	52	71.002	52	71.122	48
70	69.922	182	69.962	112	69.982	70	70.302	52	70.982	52	71.042	48
70	69.942	182	69.962	112	70.002	70	70.262	52	71.002	52	71.062	48
70	69.922	182	70.002	112	70.022	70	70.302	52	71.002	52	71.102	48
70	69.942	182	69.982	112	69.982	68	70.282	52	71.022	52	71.102	48
80	79.937	172	79.972	96	79.932	62	79.992	44	79.997	44	79.957	32
80	79.977	172	79.977	96	79.937	62	79.977	44	80.277	40	80.037	34
80	79.972	172	79.997	96	79.952	62	79.997	44	80.057	38	80.097	34
80	79.952	172	79.957	96	79.957	62	79.907	44	80.077	40	79.997	32
80	79.957	172	79.992	96	79.932	62	80.077	44	79.977	38	80.137	34
80	79.952	172	79.997	96	79.937	62	79.977	44	80.217	40	79.957	32
80	79.957	172	79.977	96	79.957	62	80.017	44	80.057	40	79.957	32
80	79.977	172	79.977	96	79.937	62	79.997	44	80.077	40	79.957	32
80	79.977	172	79.957	96	79.932	62	80.017	44	79.997	38	80.017	32
80	79.972	172	79.997	96	79.977	62	79.997	44	80.037	40	79.957	32
90	89.937	174	89.997	102	89.957	60	90.017	42	90.037	42	91.057	38
90	89.937	174	89.997	102	89.977	60	90.057	42	90.597	42	91.117	38
90	89.937	174	89.977	102	89.977	60	89.977	42	90.537	38	91.017	38
90	89.897	174	89.977	102	89.977	60	89.997	42	90.537	42	91.057	38
90	89.937	174	89.997	102	89.957	60	90.037	42	90.217	38	90.977	38
90	89.917	174	89.977	102	89.957	60	90.057	42	90.577	42	91.057	36
90	89.937	174	89.977	102	89.937	60	89.997	42	89.977	38	91.017	38
90	89.937	174	89.997	102	89.957	60	89.977	42	90.037	38	91.017	38
90	89.937	174	89.957	102	89.937	60	90.017	42	90.017	36	91.017	38
90	89.917	174	90.017	102	89.977	60	90.037	42	90.037	38	91.017	38
100	99.937	176	99.997	92	100.137	42	100.117	38	99.997	44	100.797	52
100	99.917	172	99.957	90	100.157	42	100.117	38	100.037	44	101.277	52
100	99.937	168	99.957	90	100.217	42	100.137	38	100.157	44	100.077	52
100	99.937	170	99.957	90	100.177	42	100.057	38	101.077	44	100.077	52
100	99.917	170	99.997	90	100.177	42	100.097	38	100.057	44	101.717	52
100	99.917	170	99.937	90	100.237	42	100.177	40	100.097	44	100.297	52
100	99.917	170	99.957	90	100.197	42	100.097	38	100.117	44	101.517	52
100	99.897	170	99.957	90	100.237	42	100.077	38	100.157	44	101.497	52
100	99.917	170	99.977	90	100.237	42	100.137	38	100.077	44	101.417	52
100	99.957	170	99.977	90	100.177	42	100.017	40	100.137	46	99.937	52

Table B.5 Angle of Laser Incidence: 10 m to 100 m

Attic, Bldg. 226										
No Filter										
Test Dates: Nov. 1, 5, and 28, 2001										
Distance	Silver, shiny									
	Rotation Angle (°)									
	60		70		80		85		90	
(m)	Dist. (m)	Inten.	Dist. (m)	Inten.	Dist. (m)	Inten.	Dist. (m)	Inten.	Dist. (m)	Inten.
10	11.109	102	11.53	74	13.333	72	9.887	50	9.567	74
10	11.169	102	11.53	74	13.353	72	9.867	52	9.567	74
10	11.169	102	11.55	74	13.333	72	9.987	52	9.607	74
10	11.129	102	11.55	74	13.333	74	9.847	52	9.607	74
10	11.169	102	11.57	74	13.333	72	9.887	52	9.562	74
10	11.109	102	11.55	74	13.373	72	9.907	50	9.587	74
10	11.149	102	11.55	74	13.353	72	9.887	50	9.567	74
10	11.169	102	11.53	74	13.313	74	9.887	52	9.607	74
10	11.169	102	11.57	74	13.333	72	9.807	50	9.567	74
10	11.129	102	11.55	74	13.313	72	9.867	50	9.607	74
20	19.902	66	20.042	48	20.142	56	19.882	60	19.782	76
20	19.902	66	20.062	48	20.182	56	19.862	60	19.962	76
20	19.882	66	20.022	48	20.082	58	19.822	58	19.802	78
20	19.882	66	20.042	48	20.162	58	19.842	58	19.822	78
20	19.902	64	20.062	48	20.142	58	19.842	60	19.802	78
20	19.902	64	20.082	48	20.142	56	19.882	58	19.802	78
20	19.902	66	20.002	48	20.202	58	19.842	60	19.802	78
20	19.922	64	20.042	48	20.082	58	19.842	60	19.762	78
20	19.882	66	20.062	48	20.162	56	19.862	60	19.802	78
20	19.902	66	20.062	48	20.142	58	19.882	60	19.782	78
30	31.22	66	31.956	56	30.276	62	30.036	58	29.776	68
30	31.24	66	31.96	56	30.136	62	29.976	58	29.796	68
30	31.216	66	31.976	56	30.196	62	29.996	58	29.776	68
30	31.216	66	31.976	56	30.056	62	30.056	58	29.756	68
30	31.196	66	31.956	56	30.076	62	30.016	58	29.756	68
30	31.176	66	31.956	56	30.176	62	29.896	58	29.836	68
30	31.216	66	31.936	56	30.176	62	29.936	58	29.836	68
30	31.196	66	31.976	56	30.096	60	29.956	58	29.796	68
30	31.176	66	31.936	56	30.216	62	29.936	58	29.816	68
30	31.196	66	31.916	56	30.156	62	29.896	58	29.816	68
40	41.576	52	40.411	42	39.951	50	39.871	54	39.651	64
40	41.576	52	40.596	42	39.851	48	39.951	54	39.711	64
40	41.551	52	40.451	42	39.871	50	39.931	54	39.731	64
40	41.571	52	40.651	42	39.911	50	39.951	54	39.691	64
40	41.596	52	40.431	42	39.871	48	39.991	54	39.691	64
40	41.591	52	40.371	42	39.971	50	39.831	54	39.651	66
40	41.611	52	40.531	42	39.891	48	40.051	54	39.651	64
40	41.556	52	40.491	42	39.891	50	39.971	54	39.691	64
40	41.551	52	40.551	42	39.891	50	39.831	54	39.691	64
40	41.551	50	40.531	42	39.911	48	39.811	54	39.671	66
50	51.242	48	52.542	78	50.382	52	50.042	54	49.602	74
50	50.962	46	51.742	54	51.022	50	49.982	54	109.317	74
50	50.982	46	51.742	52	50.722	50	50.002	54	109.317	74
50	50.982	46	51.722	54	51.642	50	50.062	54	109.337	74
50	51.022	48	51.737	54	50.982	52	49.842	88	109.322	74
50	51.022	48	51.762	54	50.862	52	50.157	56	109.282	74
50	50.962	46	51.722	54	50.902	52	50.162	54	109.322	74
50	50.982	46	51.722	54	50.822	52	50.022	54	109.342	74
50	50.982	48	51.722	54	50.742	52	50.077	54	49.722	74
50	50.982	48	51.722	54	50.322	52	50.022	54	109.297	74
60	60.845	64	60.96	48	62.6	66	59.736	68	59.636	74
60	60.86	64	61	48	62.56	66	59.816	68	59.596	74
60	60.86	64	60.98	48	62.576	66	59.796	68	59.656	74
60	60.9	64	60.92	48	62.54	66	59.796	68	59.616	74
60	60.885	64	61.02	48	62.52	66	59.876	68	59.536	74
60	60.88	64	61.02	48	62.516	66	59.916	68	59.616	74
60	60.88	64	60.92	48	62.52	66	59.916	68	59.536	74

Table B.5 Angle of Laser Incidence: 10 m to 100 m

Attic, Bldg. 226										
No Filter										
Test Dates: Nov. 1, 5, and 28, 2001										
Distance	Silver, shiny									
	Rotation Angle (°)									
	60		70		80		85		90	
(m)	Dist. (m)	Inten.	Dist. (m)	Inten.	Dist. (m)	Inten.	Dist. (m)	Inten.	Dist. (m)	Inten.
60	60.86	64	60.96	48	62.576	66	59.996	68	59.636	74
60	60.86	64	61.02	48	62.556	66	59.956	68	59.636	74
60	60.84	64	61	48	62.476	66	59.676	68	59.596	74
70	71.122	42	72.022	54	73.302	62	69.837	66	69.577	70
70	71.122	44	71.882	52	73.402	62	90.457	66	69.717	70
70	71.102	44	71.962	54	73.342	62	90.682	66	69.717	70
70	71.162	44	71.902	52	73.422	62	90.697	66	69.757	70
70	71.102	44	71.862	52	73.362	62	90.637	66	69.557	70
70	71.142	44	71.922	52	73.277	62	90.437	66	69.697	70
70	71.122	44	72.017	52	73.317	62	90.602	66	69.657	72
70	71.022	44	72.042	52	73.317	62	90.477	66	69.697	70
70	71.137	44	71.982	52	73.337	62	90.737	66	69.762	70
70	71.122	44	71.902	54	73.377	62	90.577	66	69.677	70
80	79.977	40	90.717	64	90.797	66	90.197	68	79.637	74
80	80.057	40	90.897	64	90.877	66	90.272	68	79.617	72
80	79.937	40	90.777	64	91.137	66	90.257	68	79.617	74
80	79.997	40	90.597	64	90.772	66	90.257	70	79.492	74
80	79.997	40	90.777	64	91.017	66	90.257	68	79.557	74
80	79.997	40	109.957	64	90.727	66	90.312	68	79.953	74
80	79.997	40	110.112	62	91.072	66	90.197	68	79.537	74
80	79.977	40	90.797	64	90.957	66	90.377	70	79.577	74
80	79.992	40	90.817	64	90.977	68	90.377	68	79.577	74
80	79.997	40	90.557	64	90.617	66	90.317	68	79.697	74
90	91.197	56	109.117	64	94.397	68	97.237	68	89.657	72
90	91.917	56	109.137	64	94.457	68	97.117	70	89.777	72
90	91.277	56	91.737	64	94.397	68	96.897	70	89.777	72
90	91.177	56	109.117	64	94.397	68	97.277	70	89.717	72
90	91.237	56	91.837	64	94.497	68	96.997	70	89.737	72
90	91.297	56	109.137	64	94.417	68	97.157	70	89.637	72
90	91.197	56	109.137	64	94.457	68	97.017	70	89.737	72
90	91.217	58	91.197	64	94.597	68	97.057	68	89.737	72
90	91.277	56	109.137	64	94.337	68	97.237	70	89.697	72
90	91.237	54	91.697	64	94.477	68	97.237	68	89.757	72
100	110.077	64	109.677	66	109.537	70	109.417	70	99.817	76
100	110.037	64	109.657	66	109.537	70	109.417	70	99.597	76
100	109.957	64	109.657	66	109.537	68	109.397	70	99.677	76
100	110.017	64	109.697	66	109.537	70	109.377	70	99.737	76
100	110.097	64	109.657	66	109.537	70	109.397	70	99.677	76
100	110.037	64	109.577	66	109.477	70	109.377	70	99.617	76
100	109.977	64	109.597	66	109.537	70	109.377	70	99.557	76
100	102.777	64	109.657	66	109.557	70	109.397	70	99.697	76
100	109.877	64	109.717	66	109.497	70	109.417	70	99.757	76
100	109.997	64	109.657	66	109.517	70	109.397	70	99.677	76

Table B.5 Angle of Laser Incidence: 10 m to 100 m

Attic, Bldg. 226												
No Filter												
Test Dates: Nov. 1, 5, and 28, 2001												
Distance (m)	White											
	Rotation Angle (°)											
	0		10		20		30		40		50	
	Dist. (m)	Inten.	Dist. (m)	Inten.	Dist. (m)	Inten.	Dist. (m)	Inten.	Dist. (m)	Inten.	Dist. (m)	Inten.
10	9.967	150	10.003	150	9.942	148	10.003	148	10.003	144	10.023	142
10	9.982	150	10.008	150	9.982	150	10.003	148	9.982	144	10.003	142
10	9.962	150	9.982	150	10.003	148	9.982	148	9.982	144	10.023	142
10	10.003	150	9.962	150	9.982	150	9.982	146	9.982	144	10.003	142
10	9.982	150	10.003	150	9.962	148	10.023	148	10.003	144	10.023	142
10	9.962	150	9.982	150	10.003	148	10.003	148	10.003	144	9.982	142
10	9.962	150	9.982	150	9.982	148	9.962	146	10.003	144	9.982	142
10	9.982	150	9.942	150	9.982	150	10.003	148	9.962	144	10.023	142
10	10.003	150	10.003	150	10.003	148	10.003	148	10.003	144	9.982	142
10	9.967	150	9.942	150	9.962	148	9.962	146	10.003	144	9.982	142
20	19.982	150	20.002	150	19.962	148	20.002	146	20.002	144	19.962	140
20	19.982	150	19.962	150	19.982	148	19.982	146	19.962	144	19.962	140
20	20.002	150	19.982	150	20.002	148	20.002	146	20.002	144	20.002	140
20	19.962	150	20.002	150	20.002	148	20.022	146	19.982	144	20.002	140
20	19.982	150	20.002	150	20.002	148	20.022	146	19.982	144	19.962	140
20	20.002	150	19.962	150	20.002	148	20.002	146	19.982	144	19.982	140
20	20.002	150	20.002	150	20.002	148	20.002	146	19.982	144	20.002	140
20	19.982	150	20.002	150	20.002	148	20.002	146	20.002	144	19.982	140
20	20.002	150	20.002	150	19.982	148	20.002	146	20.002	144	20.022	140
20	19.962	150	20.002	150	19.962	148	20.002	146	19.962	144	20.002	140
30	29.996	138	30.016	138	29.976	136	29.976	134	29.971	130	29.991	126
30	29.976	138	29.976	136	29.996	136	30.016	134	29.951	130	29.991	126
30	29.996	138	29.976	136	29.956	136	29.976	134	29.991	130	29.971	126
30	30.016	138	29.976	136	29.976	136	29.996	134	29.991	130	30.011	126
30	30.016	138	29.996	136	29.996	136	29.991	134	29.951	130	29.951	126
30	29.976	138	29.996	138	29.996	136	29.976	134	29.991	130	29.971	126
30	29.996	138	29.936	136	29.996	136	29.976	134	29.971	130	29.991	126
30	29.996	138	29.976	136	29.996	136	30.011	134	29.971	130	29.971	126
30	30.016	138	29.996	136	29.956	136	29.991	134	29.991	130	29.971	126
30	29.976	138	29.976	136	29.956	136	29.951	134	29.971	130	29.991	126
40	39.971	120	40.011	120	39.991	120	39.986	118	39.966	114	39.966	112
40	39.991	122	39.951	120	39.971	120	39.971	118	40.011	116	40.006	112
40	39.991	122	39.991	120	40.006	120	39.971	118	40.006	116	39.986	112
40	39.991	122	39.951	120	39.991	120	40.031	118	39.986	116	39.966	112
40	40.011	122	39.971	120	39.991	120	39.986	118	39.986	116	39.986	112
40	40.031	122	39.951	120	39.991	120	39.986	118	40.006	116	39.986	112
40	39.971	122	40.011	120	39.971	120	39.986	118	39.986	116	40.006	112
40	39.991	122	39.951	120	40.011	120	39.951	118	40.006	116	40.006	112
40	40.011	122	39.971	120	39.991	120	39.971	118	40.006	116	40.006	112
40	39.991	122	39.991	120	39.946	120	39.966	118	40.006	116	39.966	112
50	49.977	108	50.017	108	49.977	108	50.037	106	49.997	102	50.017	98
50	49.977	108	50.017	108	50.017	108	50.017	106	49.977	102	49.997	100
50	49.977	108	49.997	108	50.017	108	49.997	106	49.997	102	50.037	100
50	49.957	108	50.017	108	50.017	108	50.017	106	49.997	102	50.017	100
50	49.997	108	49.977	108	50.017	108	50.017	106	50.037	104	50.017	98
50	49.977	108	50.017	108	49.997	108	50.017	106	50.017	102	49.997	98
50	49.997	108	49.982	108	49.997	108	50.017	106	50.022	104	50.017	100
50	49.997	108	49.997	108	49.977	108	50.017	106	49.977	104	50.037	100
50	49.997	108	50.017	108	50.037	108	49.997	106	49.997	102	50.037	100
50	49.977	108	50.017	108	50.017	108	49.977	106	50.017	104	49.997	100
60	59.976	100	59.991	100	60.011	98	59.991	96	59.971	94	59.991	90
60	59.996	100	59.991	100	60.011	98	59.991	98	59.931	94	59.971	90
60	59.976	100	59.991	100	59.951	98	59.991	96	59.991	94	59.951	90
60	60.011	100	59.971	100	60.011	98	59.951	96	59.971	94	59.991	90
60	60.011	100	59.951	100	59.971	98	59.971	98	59.971	94	59.991	90
60	59.991	100	59.991	100	59.991	98	59.991	96	59.991	94	60.011	90
60	59.971	100	59.931	100	60.011	98	59.971	96	59.971	94	59.991	90

Table B.5 Angle of Laser Incidence: 10 m to 100 m

Attic, Bldg. 226												
No Filter												
Test Dates: Nov. 1, 5, and 28, 2001												
Distance (m)	White											
	Rotation Angle (°)											
	0		10		20		30		40		50	
	Dist. (m)	Inten.	Dist. (m)	Inten.	Dist. (m)	Inten.	Dist. (m)	Inten.	Dist. (m)	Inten.	Dist. (m)	Inten.
60	59.991	100	59.991	100	60.011	98	59.991	96	60.011	94	59.971	90
60	59.971	100	60.011	100	59.991	98	60.011	98	60.011	94	59.971	90
60	59.991	100	59.971	100	59.991	98	59.991	96	59.971	94	59.991	90
70	69.677	70	69.957	90	69.977	90	69.977	88	69.997	86	69.977	80
70	69.977	90	69.977	90	69.977	90	69.977	88	69.957	84	69.997	80
70	69.957	90	69.957	90	69.977	90	69.977	88	69.957	84	69.977	80
70	69.957	90	69.977	90	69.997	90	69.997	88	70.017	84	69.957	80
70	69.957	90	69.957	90	69.997	90	69.997	88	69.957	84	69.997	82
70	69.957	90	69.977	90	70.017	90	69.957	88	69.957	84	69.977	80
70	69.977	90	69.997	90	69.997	90	69.997	88	69.977	84	69.957	80
70	69.957	90	69.977	90	69.997	90	69.977	88	69.997	84	69.977	80
70	69.997	90	69.957	90	69.997	90	69.977	88	69.977	84	69.997	82
70	69.937	90	69.957	90	69.957	90	69.997	88	69.997	84	69.977	80
80	79.997	84	79.992	84	79.992	82	79.972	80	79.972	78	79.937	74
80	79.972	84	79.992	84	79.992	82	79.977	80	79.977	78	79.977	76
80	79.977	84	79.972	84	79.972	82	79.972	80	79.977	78	79.952	76
80	79.997	84	79.997	84	79.977	82	79.992	80	79.957	78	79.977	74
80	79.997	84	79.997	84	79.972	82	79.977	80	79.952	78	79.977	74
80	79.972	84	79.952	84	79.992	82	80.017	80	79.957	78	79.952	74
80	79.957	84	79.972	84	79.992	82	79.977	80	79.952	78	79.932	76
80	79.992	84	79.992	84	79.997	82	79.972	80	79.977	78	79.972	74
80	79.992	84	79.992	84	80.012	82	79.997	80	79.957	78	79.972	74
80	79.972	84	79.952	84	79.997	82	79.952	80	79.977	78	79.957	74
90	89.957	78	89.997	78	89.977	78	89.957	76	89.957	74	89.957	70
90	89.997	78	89.997	78	89.957	78	89.957	76	89.977	74	89.957	70
90	89.957	78	89.957	78	89.977	78	89.957	76	89.937	74	89.937	70
90	89.957	78	89.957	78	89.977	78	89.977	76	89.957	74	89.957	70
90	89.977	78	89.977	78	89.957	78	89.977	76	89.957	74	89.957	70
90	89.957	78	89.957	78	89.957	78	89.957	76	89.957	74	89.957	70
90	89.977	78	89.957	78	89.977	78	89.977	76	89.957	74	89.997	70
90	89.997	78	89.957	78	89.977	78	89.957	76	89.937	74	89.937	70
90	89.957	78	89.977	78	89.977	78	89.977	76	89.957	74	89.957	70
90	89.977	78	89.977	78	89.977	76	89.977	76	89.937	74	89.977	70
100	99.937	74	99.957	74	99.937	74	99.937	72	99.917	68	99.837	68
100	99.957	76	99.937	74	99.937	74	99.917	72	99.937	68	99.817	68
100	99.957	76	99.937	74	99.937	74	99.917	72	99.937	68	99.797	66
100	99.957	76	99.937	74	99.917	74	99.957	72	99.897	68	99.817	68
100	99.937	76	99.937	74	99.937	74	99.897	72	99.897	68	99.817	68
100	99.957	76	99.937	74	99.937	74	99.917	72	99.917	68	99.837	66
100	99.937	76	99.937	74	99.957	74	99.917	72	99.897	70	99.817	66
100	99.957	76	99.957	74	99.957	74	99.937	72	99.917	68	99.817	68
100	99.957	76	99.937	74	99.937	74	99.937	72	99.917	68	99.817	66
100	99.957	76	99.937	74	99.917	74	99.937	72	99.917	68	99.817	66

Table B.5 Angle of Laser Incidence: 10 m to 100 m

Attic, Bldg. 226										
No Filter										
Test Dates: Nov. 1, 5, and 28, 2001										
White										
Rotation Angle (°)										
Distance (m)	60		70		80		85		90	
	Dist. (m)	Inten.	Dist. (m)	Inten.	Dist. (m)	Inten.	Dist. (m)	Inten.	Dist. (m)	Inten.
10	9.962	136	9.962	132	9.982	126	10.023	118	9.762	74
10	10.003	136	10.003	132	9.982	126	10.003	118	9.722	74
10	9.962	136	10.003	132	10.003	126	10.023	118	9.762	74
10	10.003	136	10.003	132	10.003	126	10.003	118	9.762	74
10	10.003	136	9.962	132	10.023	126	10.023	118	9.682	74
10	9.982	136	10.003	132	9.962	126	10.023	118	9.762	74
10	10.023	136	10.023	132	10.003	128	10.023	118	9.742	74
10	9.962	136	10.003	132	10.023	128	10.023	118	9.742	74
10	9.982	136	10.003	132	10.003	126	10.023	118	9.742	74
10	10.023	138	9.962	132	10.003	128	9.982	118	9.762	74
20	19.982	136	20.002	132	20.042	124	20.022	112	19.802	104
20	20.002	136	20.022	132	20.022	124	20.002	112	19.842	104
20	20.002	136	19.982	132	20.022	124	20.022	112	19.802	104
20	20.022	136	20.022	132	20.042	124	20.002	112	19.822	104
20	20.002	136	20.022	132	20.042	124	19.982	112	19.842	104
20	20.002	136	19.982	132	20.022	124	19.982	112	19.842	104
20	20.022	136	19.982	132	20.002	124	20.002	112	19.822	104
20	20.002	136	19.982	132	20.022	124	19.982	112	19.822	102
20	20.002	136	20.042	132	20.042	124	20.002	112	19.802	104
20	19.962	136	20.022	132	20.042	124	19.962	112	19.842	104
30	29.971	122	29.991	116	29.971	100	30.071	82	29.751	70
30	30.011	122	29.991	116	29.971	100	30.011	82	29.771	70
30	29.991	122	29.991	116	29.911	100	30.071	82	29.751	72
30	29.991	122	30.011	116	29.951	100	30.031	82	29.731	70
30	30.011	122	29.991	116	29.911	100	30.051	82	29.751	70
30	29.991	122	30.011	116	29.931	100	30.051	82	29.771	70
30	29.991	122	29.991	116	29.951	100	30.051	82	29.771	70
30	29.991	122	29.991	116	29.951	100	30.051	82	29.771	72
30	30.011	122	30.011	116	29.931	100	30.051	82	29.811	70
30	29.991	122	30.011	116	29.931	100	30.051	82	29.751	70
40	40.006	108	39.966	100	39.966	78	39.986	74	39.846	70
40	40.026	108	40.006	100	39.966	80	39.966	74	39.846	70
40	40.006	108	39.966	100	39.946	80	39.966	72	39.826	70
40	40.006	108	39.986	100	39.946	78	39.966	74	39.846	70
40	40.026	108	40.006	100	39.966	80	39.966	74	39.846	70
40	40.006	108	40.006	100	39.966	80	39.946	74	39.826	70
40	40.006	108	40.006	100	39.966	78	39.966	74	39.846	70
40	40.026	108	39.986	100	39.966	78	39.966	72	39.806	70
40	39.966	108	40.006	100	39.966	78	39.966	72	39.866	70
40	39.986	108	39.986	100	39.966	78	39.966	74	39.846	70
50	50.037	94	49.977	82	49.977	72	50.037	58	49.697	74
50	49.997	94	49.957	82	49.957	72	50.037	58	49.717	74
50	49.977	94	49.977	82	49.957	72	50.057	58	49.897	74
50	49.977	94	49.977	82	49.937	72	50.037	58	49.617	74
50	49.997	94	49.977	82	49.957	72	50.077	58	49.797	74
50	50.017	94	49.977	82	49.957	72	50.077	58	49.657	74
50	49.977	94	49.997	82	49.917	72	50.017	58	49.777	74
50	49.997	94	49.937	82	49.917	72	50.037	58	49.837	74
50	49.997	94	49.957	82	49.957	72	50.037	58	49.797	74
50	50.037	94	49.957	82	49.937	72	50.037	58	49.797	74
60	59.991	84	59.986	70	59.926	62	59.866	62	59.646	70
60	59.991	84	59.966	70	59.946	60	59.886	62	59.726	70
60	59.971	84	59.946	70	59.966	62	59.926	62	59.726	70
60	60.006	84	59.946	70	59.946	62	59.906	62	59.686	70
60	59.966	84	59.906	70	59.946	62	59.886	62	59.726	70
60	60.011	84	59.966	70	59.926	62	59.886	64	59.726	70
60	60.006	84	59.926	70	59.946	62	59.886	62	59.746	70

60	59.966	84	59.946	70	59.986	62	59.906	62	59.706	70
60	59.966	84	59.926	70	59.946	62	59.926	62	59.766	70
60	59.971	84	59.946	70	59.926	62	59.926	62	59.686	70
70	69.957	76	69.957	60	69.957	58	69.937	60	69.697	70
70	69.957	76	69.937	60	69.977	58	69.957	60	69.697	70
70	69.957	76	69.977	60	69.977	58	69.977	60	69.657	70
70	69.957	76	69.957	60	69.937	58	69.957	60	69.717	70
70	69.977	76	69.997	60	69.997	58	70.017	60	69.717	70
70	69.957	76	69.997	60	69.977	58	69.957	60	69.637	70
70	69.977	76	69.997	60	69.997	58	69.937	60	69.677	70
70	69.977	76	69.957	60	69.997	58	69.997	60	69.717	70
70	69.977	76	69.977	60	70.017	58	69.957	60	69.637	70
70	69.977	76	69.957	60	69.997	58	69.957	60	69.797	70
80	79.957	66	79.932	60	79.872	62	79.812	66	79.577	72
80	79.952	66	79.957	58	79.832	64	79.852	66	79.617	72
80	79.932	66	79.932	60	79.892	62	79.857	66	79.592	72
80	79.957	66	79.957	60	79.897	62	79.837	66	79.617	72
80	79.952	66	79.932	60	79.857	62	79.832	66	79.677	72
80	79.977	66	79.952	58	79.872	62	79.827	66	79.592	72
80	79.932	66	79.952	58	79.852	62	79.852	66	79.517	72
80	79.897	66	79.957	60	79.832	62	79.817	66	79.692	72
80	79.937	66	79.912	60	79.892	62	79.812	66	79.692	72
80	79.937	66	79.912	58	79.892	62	79.832	66	79.592	72
90	89.977	58	89.817	64	89.837	66	89.817	68	89.717	72
90	89.937	58	89.837	66	89.857	66	89.837	70	89.677	72
90	89.937	58	89.817	66	89.837	68	89.877	68	89.737	72
90	89.977	58	89.837	66	89.817	66	89.877	68	89.697	74
90	89.957	58	89.857	64	89.837	66	89.857	68	89.697	72
90	89.977	58	89.817	66	89.837	66	89.857	68	89.597	74
90	89.937	58	89.817	66	89.877	68	89.817	68	89.677	72
90	89.937	58	89.797	66	89.837	68	89.837	68	89.617	72
90	89.937	58	89.857	64	89.817	68	89.837	68	89.657	72
90	89.957	58	89.857	64	89.817	68	89.817	68	89.657	74
100	99.717	72	99.717	74	99.737	74	99.637	76	99.817	74
100	99.717	72	99.737	74	99.737	74	99.657	76	99.737	74
100	99.717	72	99.677	74	99.757	76	99.757	76	99.997	74
100	99.717	72	99.717	74	99.817	74	99.717	76	109.157	74
100	99.717	72	99.737	74	99.717	76	99.717	76	99.757	74
100	99.737	72	99.737	74	99.757	74	99.657	76	99.857	74
100	99.677	72	99.737	74	99.817	76	99.637	76	99.857	74
100	99.737	72	99.717	74	99.717	74	99.697	76	99.577	74
100	99.697	72	99.677	74	99.717	76	99.717	76	109.177	74
100	99.717	72	99.717	74	99.717	74	99.677	76	99.777	74

Table B.5 Angle of Laser Incidence: 10 m to 100 m

Attic, Bldg. 226												
No Filter												
Test Dates: Nov. 1, 5, and 28, 2001												
Black												
Distance	Rotation Angle (°)											
	0		10		20		30		40		50	
	Dist. (m)	Inten.	Dist. (m)	Inten.	Dist. (m)	Inten.	Dist. (m)	Inten.	Dist. (m)	Inten.	Dist. (m)	Inten.
10	10.023	76	9.962	74	10.003	68	10.023	60	10.003	48	10.023	42
10	10.003	76	10.003	74	10.003	68	10.023	58	10.003	48	10.003	42
10	9.962	76	10.003	74	9.982	68	10.003	58	10.043	48	10.043	42
10	10.023	78	10.003	74	9.982	68	9.982	60	10.063	48	10.023	42
10	10.003	76	10.003	74	9.982	68	9.982	60	10.043	48	10.063	42
10	9.962	76	9.982	74	10.003	68	10.003	60	10.063	48	10.023	42
10	10.003	78	9.962	74	10.003	68	10.003	60	10.023	48	9.942	42
10	10.023	78	9.962	74	9.982	68	10.023	60	10.023	48	10.043	42
10	10.003	78	10.003	74	10.003	68	10.023	60	10.003	48	10.003	42
10	10.003	76	9.962	74	10.003	68	9.962	60	10.023	48	9.982	42
20	19.982	78	20.022	76	19.982	70	20.002	62	20.062	52	20.042	44
20	19.982	78	20.002	76	19.962	70	20.002	62	20.002	52	20.042	46
20	19.982	78	20.002	76	19.962	70	19.982	62	20.022	50	20.002	44
20	19.982	78	19.982	76	20.022	70	20.002	62	20.002	50	19.982	44
20	20.002	78	20.002	76	20.002	70	20.002	60	20.002	50	20.042	44
20	19.982	78	19.982	76	19.982	70	19.982	60	19.982	52	20.002	44
20	20.002	78	19.962	76	19.982	70	20.002	60	20.042	52	19.982	44
20	19.982	78	20.002	76	20.002	70	20.022	62	20.002	52	20.022	44
20	20.002	78	19.962	76	19.962	70	20.002	60	19.962	50	19.982	44
20	20.002	78	20.002	76	20.002	70	20.022	60	20.022	52	20.022	44
30	29.991	68	29.971	66	30.031	58	30.011	48	30.011	40	30.031	36
30	29.971	68	29.991	66	29.971	58	29.971	48	30.051	42	29.991	36
30	29.991	68	29.971	66	29.991	58	30.011	48	30.031	42	30.011	36
30	29.951	68	29.951	66	29.991	58	29.971	48	29.971	40	29.971	36
30	29.991	68	29.951	66	30.011	58	29.991	48	29.946	40	30.031	36
30	29.991	68	29.931	66	29.991	58	30.011	48	29.991	42	29.986	36
30	29.971	68	29.951	66	29.991	58	30.011	48	29.991	40	29.991	36
30	29.971	68	29.971	66	29.971	58	30.011	48	30.011	40	30.031	36
30	29.971	68	29.931	66	29.971	58	30.031	48	30.011	40	29.986	36
30	29.991	68	29.971	66	29.991	58	29.991	48	30.031	40	30.046	36
40	40.026	58	39.966	56	39.986	50	39.966	42	39.966	34	40.066	30
40	40.026	58	39.966	56	40.026	50	40.006	42	40.026	34	39.946	28
40	39.986	58	40.026	56	39.986	50	39.966	42	39.966	34	39.946	30
40	40.026	58	39.986	56	40.026	50	40.006	42	40.006	34	39.966	30
40	39.966	58	39.986	56	40.066	50	40.006	42	40.026	34	40.006	30
40	39.946	58	39.986	56	40.006	50	40.006	42	40.046	34	39.926	30
40	39.966	58	40.006	56	40.026	50	39.986	42	40.006	34	40.006	30
40	40.006	58	40.006	56	40.006	50	40.006	42	40.046	34	39.986	30
40	39.986	58	39.966	56	39.986	50	39.986	42	40.006	34	40.046	30
40	39.986	58	40.006	56	39.966	50	40.006	42	39.986	34	40.006	30
50	49.997	50	49.977	48	49.997	44	49.997	36	49.977	30	49.997	24
50	49.997	48	49.997	48	50.017	42	49.977	36	49.997	28	49.957	24
50	49.997	48	50.017	48	49.997	44	50.017	36	50.037	28	49.997	22
50	50.017	50	49.977	48	50.017	42	50.057	36	49.977	28	49.977	24
50	49.997	50	49.977	48	50.017	44	50.017	36	49.977	30	49.937	22
50	49.977	50	50.017	48	49.997	44	50.077	36	50.017	30	50.077	24
50	49.997	48	49.957	48	50.017	44	49.997	36	49.997	28	49.997	24
50	49.937	48	50.037	48	50.017	44	50.037	36	50.077	30	49.937	22
50	49.977	50	49.997	48	49.997	44	50.017	36	50.077	30	50.117	24
50	49.977	50	50.057	48	50.017	44	50.017	36	50.017	28	49.997	24
60	59.926	44	60.006	42	60.026	38	59.942	32	59.962	24	59.942	18
60	59.966	44	59.926	42	59.966	38	59.982	32	59.942	26	60.042	20
60	59.986	46	59.986	42	59.982	38	59.982	32	59.962	24	60.062	20
60	60.006	44	59.986	44	60.002	38	60.022	32	59.962	26	60.042	22
60	59.986	44	60.022	42	59.986	38	60.042	32	60.062	24	60.022	20
60	59.906	44	59.966	42	59.902	38	60.022	32	59.942	26	60.082	20
60	60.006	46	60.006	42	59.962	38	60.022	30	59.982	26	60.102	20

Table B.5 Angle of Laser Incidence: 10 m to 100 m

Attic, Bldg. 226												
No Filter												
Test Dates: Nov. 1, 5, and 28, 2001												
Black												
Rotation Angle (°)												
Distance (m)	0		10		20		30		40		50	
	Dist. (m)	Inten.	Dist. (m)	Inten.	Dist. (m)	Inten.	Dist. (m)	Inten.	Dist. (m)	Inten.	Dist. (m)	Inten.
60	59.966	44	60.006	42	59.942	38	59.962	32	59.982	26	60.062	18
60	60.026	44	59.962	42	59.982	38	60.062	32	60.042	24	59.962	20
60	60.006	44	59.966	42	60.002	38	59.942	32	59.902	26	59.922	18
70	69.957	40	70.017	38	70.037	32	69.977	26	69.937	20	70.057	14
70	69.977	40	69.997	38	70.017	32	69.977	26	70.077	20	69.937	14
70	69.977	38	69.997	36	69.997	32	69.937	26	69.937	20	69.897	18
70	70.017	40	70.017	38	69.997	32	69.987	26	69.997	20	70.237	14
70	69.997	40	69.997	36	69.997	32	69.937	26	69.897	20	70.137	16
70	69.977	38	69.937	38	69.977	34	69.917	26	69.937	20	69.957	16
70	70.017	40	69.917	38	69.957	32	70.057	26	70.037	22	69.977	14
70	69.997	40	69.937	38	69.977	32	70.017	26	69.897	20	70.077	16
70	69.977	38	69.957	38	69.937	32	69.937	26	69.917	20	69.917	16
70	69.997	40	69.997	36	69.937	32	70.077	26	69.957	18	69.997	16
80	79.992	36	79.017	34	79.932	30	79.997	22	79.837	16	80.017	24
80	79.997	36	79.972	34	79.932	30	79.987	22	79.957	16	110.057	24
80	79.997	36	79.957	34	80.017	30	80.037	24	80.017	16	109.857	22
80	79.997	36	79.972	34	80.017	30	79.937	22	79.972	16	80.137	20
80	80.012	36	79.997	34	80.032	30	79.832	22	80.037	14	80.112	22
80	80.017	36	80.012	34	79.977	30	80.037	22	80.037	16	109.817	24
80	80.017	36	79.972	36	79.997	28	80.012	22	79.917	16	110.077	22
80	79.997	36	79.997	34	79.977	28	79.997	22	80.117	16	110.037	22
80	79.977	36	79.997	34	79.932	30	79.997	22	80.017	16	79.997	24
80	79.952	36	79.977	34	79.977	28	79.957	22	80.237	16	80.177	24
90	89.977	34	89.977	32	89.957	26	89.937	20	90.097	24	109.297	32
90	89.977	34	89.977	32	89.977	28	89.977	20	89.977	24	109.337	32
90	90.037	34	89.977	32	89.997	28	90.017	20	90.097	24	109.317	32
90	89.997	34	89.997	32	89.897	28	89.957	20	90.157	24	109.377	32
90	89.977	34	89.957	32	89.857	28	89.977	20	90.097	24	109.317	32
90	89.997	34	90.057	32	90.057	28	89.897	20	90.137	24	109.257	32
90	89.957	34	89.977	32	89.937	28	90.017	20	90.177	24	109.437	32
90	89.977	34	89.957	32	90.037	28	90.017	20	90.077	24	109.277	32
90	89.917	34	89.957	32	89.997	28	89.897	20	90.017	24	109.397	32
90	90.017	34	89.977	32	89.997	26	90.037	20	90.077	22	109.397	32
100	100.017	32	100.037	30	99.997	30	99.997	30	100.137	32	109.257	46
100	99.917	32	100.037	30	100.057	30	100.077	30	100.197	32	109.277	44
100	99.997	32	100.017	30	99.917	30	100.097	30	100.157	32	109.237	46
100	99.957	32	99.957	32	100.057	30	99.977	30	100.137	32	109.257	46
100	99.977	32	99.997	32	99.977	30	99.917	30	100.317	32	109.317	44
100	99.997	32	99.937	32	99.937	30	99.997	30	109.217	32	109.257	44
100	99.997	32	100.017	32	100.017	30	99.997	30	100.237	32	109.237	46
100	99.917	32	99.917	32	99.937	30	100.057	30	100.117	32	109.277	44
100	100.057	32	99.937	32	100.097	30	100.017	30	100.317	32	109.277	44
100	99.937	32	99.957	32	99.997	30	99.977	30	100.137	32	109.277	44

Table B.5 Angle of Laser Incidence: 10 m to 100 m

Attic, Bldg. 226										
No Filter										
Test Dates: Nov. 1, 5, and 28, 2001										
Black										
Distance	Rotation Angle (°)									
	60		70		80		85		90	
	Dist. (m)	Inten.	Dist. (m)	Inten.	Dist. (m)	Inten.	Dist. (m)	Inten.	Dist. (m)	Inten.
10	10.063	38	10.063	38	10.063	36	10.003	42	9.702	76
10	10.083	38	10.023	38	10.063	38	10.003	42	9.622	76
10	10.063	38	10.023	36	10.063	38	10.003	42	9.702	76
10	10.023	38	10.043	38	10.043	38	10.023	42	9.582	76
10	10.003	38	10.043	38	10.083	38	9.942	42	9.742	76
10	10.043	38	10.023	38	10.063	38	10.043	42	9.642	76
10	10.043	38	9.962	38	10.043	38	10.023	42	9.762	76
10	10.023	38	10.003	38	10.103	38	10.023	42	9.722	76
10	10.023	38	10.023	38	10.023	38	10.063	42	9.642	76
10	10.083	38	10.043	38	10.023	38	9.982	42	9.722	76
20	20.002	42	20.022	40	20.062	42	20.022	52	19.702	70
20	19.962	42	20.042	40	20.082	42	20.002	52	19.642	70
20	20.042	42	20.062	40	20.062	42	20.042	52	19.662	70
20	20.022	42	20.022	40	20.082	42	20.022	52	19.682	70
20	20.042	42	20.062	40	20.042	42	20.022	52	19.662	70
20	19.982	42	20.002	40	20.042	42	20.002	52	19.622	70
20	20.062	42	20.022	40	20.022	42	19.982	52	19.682	70
20	20.022	42	20.062	40	20.002	42	19.982	52	19.682	70
20	20.002	42	20.022	42	20.062	42	19.982	52	19.662	70
20	20.042	42	20.022	40	20.102	42	20.042	52	19.702	70
30	30.011	34	29.946	34	30.006	50	30.046	58	29.886	66
30	30.071	34	30.011	34	29.966	50	30.046	58	29.886	66
30	30.011	34	30.015	34	29.966	52	30.046	58	29.886	66
30	30.011	34	30.026	34	29.966	50	30.086	58	29.886	66
30	30.026	34	29.966	34	29.986	50	30.106	58	29.886	66
30	30.051	34	30.011	34	29.986	50	30.066	58	29.886	66
30	30.026	34	30.026	34	30.026	50	30.091	56	29.906	66
30	30.031	34	30.111	34	30.006	50	30.066	58	29.906	66
30	29.991	34	29.971	34	29.946	52	30.146	58	29.946	66
30	29.966	34	30.006	34	29.986	50	30.126	58	29.866	66
40	40.046	28	39.986	26	40.086	52	40.002	54	39.842	68
40	39.946	26	39.966	26	40.146	50	40.042	54	39.802	68
40	39.946	26	40.106	26	40.006	50	40.106	54	39.782	68
40	40.006	28	39.966	26	40.146	50	40.082	54	39.762	68
40	39.966	26	39.926	26	40.062	50	40.182	54	39.862	68
40	39.966	26	40.006	26	40.022	50	40.162	54	39.762	68
40	40.006	26	40.102	26	40.066	50	40.142	54	39.762	68
40	40.086	26	40.046	26	39.982	50	40.062	54	39.742	70
40	40.006	26	39.986	26	39.966	52	40.142	54	39.722	68
40	39.946	26	40.046	26	40.062	52	40.042	54	39.842	68
50	50.077	22	50.197	50	50.237	54	109.377	60	109.337	74
50	50.157	22	50.177	50	50.157	54	50.317	60	109.337	74
50	50.057	20	50.157	50	50.037	54	50.137	60	109.337	74
50	49.877	22	50.257	50	50.057	54	50.077	60	109.377	74
50	50.037	22	49.977	52	50.297	54	50.237	60	109.317	74
50	50.017	22	50.137	50	50.117	54	50.077	60	109.277	74
50	50.077	20	50.137	50	50.317	54	50.317	60	109.337	74
50	50.057	22	50.237	50	50.317	54	50.257	60	109.317	74
50	50.117	22	50.217	50	50.197	54	50.337	60	109.317	74
50	50.077	22	50.077	50	50.177	54	50.197	60	109.337	74
60	60.062	22	60.082	48	109.982	66	60.142	68	59.902	74
60	60.002	22	60.342	48	110.042	64	59.922	68	59.642	74
60	60.042	22	60.362	48	110.022	66	109.762	68	59.662	74
60	60.122	22	60.222	48	109.922	66	60.102	68	59.962	74
60	60.022	22	60.282	48	110.022	66	60.162	68	60.042	74
60	60.142	22	60.182	48	109.962	64	59.902	68	59.782	74
60	60.022	22	60.162	48	110.022	66	60.122	68	59.702	74

Table B.5 Angle of Laser Incidence: 10 m to 100 m

Attic, Bldg. 226										
No Filter										
Test Dates: Nov. 1, 5, and 28, 2001										
Black										
Distance	Rotation Angle (°)									
	60		70		80		85		90	
	Dist. (m)	Inten.	Dist. (m)	Inten.	Dist. (m)	Inten.	Dist. (m)	Inten.	Dist. (m)	Inten.
60	60.082	22	60.062	48	109.962	66	60.182	68	59.622	74
60	60.002	20	60.222	48	109.962	64	60.102	68	59.762	74
60	60.042	22	60.142	48	110.122	66	60.402	68	59.962	74
70	70.037	26	109.357	52	109.217	62	109.177	64	109.137	70
70	70.157	26	109.377	52	109.237	64	109.157	64	109.137	72
70	70.177	26	109.397	52	109.217	64	109.177	64	109.137	70
70	70.097	26	109.357	52	109.197	62	109.177	64	109.137	72
70	69.977	26	109.417	54	109.197	62	109.197	64	109.177	72
70	70.137	26	109.377	54	109.217	62	109.217	64	109.157	70
70	70.277	26	109.397	52	109.217	62	109.197	64	109.137	70
70	70.117	26	109.397	52	109.237	62	109.177	64	109.137	70
70	70.157	26	109.337	52	109.197	62	109.177	64	109.117	70
70	70.057	26	109.377	52	109.197	62	109.197	64	109.137	70
80	111.612	40	109.977	64	109.652	66	109.557	68	109.277	74
80	111.812	40	109.972	64	109.792	66	109.497	68	109.312	72
80	80.177	40	110.097	62	109.672	66	109.622	68	109.312	74
80	111.732	40	109.952	62	109.697	66	109.532	68	109.312	72
80	111.832	40	110.032	62	109.692	66	109.577	68	109.332	72
80	111.837	38	109.912	64	109.652	66	109.612	68	109.292	74
80	111.972	40	110.012	62	109.732	66	109.572	68	109.312	72
80	111.832	40	109.912	62	109.732	66	109.512	68	109.312	74
80	111.852	40	109.152	62	109.6923	66	109.572	68	109.272	72
80	111.637	40	109.992	62	109.697	66	109.572	68	109.312	74
90	109.277	52	109.157	64	109.137	64	109.177	68	109.137	72
90	109.317	52	109.137	62	109.077	66	109.117	68	109.117	72
90	109.297	52	109.157	64	109.117	66	109.097	68	109.097	74
90	109.277	52	109.157	62	109.137	66	109.097	68	109.117	74
90	109.297	54	109.177	62	109.157	66	109.097	68	109.097	72
90	109.277	52	109.117	62	109.097	66	109.137	66	109.117	72
90	109.257	52	109.177	62	109.137	66	109.117	68	109.097	74
90	109.277	52	109.157	62	109.117	66	109.137	68	109.117	72
90	109.217	52	109.157	62	109.097	66	109.117	68	109.137	72
90	109.277	54	109.197	62	109.077	66	109.117	68	109.097	72
100	110.257	62	109.637	66	109.457	68	109.317	70	109.217	74
100	110.197	64	109.637	66	109.457	68	109.337	70	109.237	74
100	110.177	62	109.737	66	109.497	68	109.417	70	109.237	74
100	110.257	62	109.737	66	109.437	68	109.397	70	109.257	74
100	110.177	62	109.617	66	109.457	68	109.357	70	109.257	74
100	110.217	62	109.637	66	109.457	68	109.357	70	109.217	74
100	110.137	62	109.597	66	109.497	68	109.357	70	109.257	74
100	110.177	62	109.557	66	109.417	68	109.317	70	109.277	74
100	110.277	62	109.677	66	109.457	68	109.397	70	109.237	74
100	110.257	62	109.677	66	109.457	68	109.357	70	109.217	74

Table B.6a. Data Set 7: Covariance, 0.045° Incremental Angle.

Attic, Bldg. 226								
Test date: Sept. 03, 2002								
Strip 1			Strip 2			Strip 3		
Range (m)	ϕ (°)	θ (°)	Range (m)	ϕ (°)	θ (°)	Range (m)	ϕ (°)	θ (°)
9.999	89.46	39.6	9.999	89.46	39.645	9.958	89.46	39.69
9.999	89.46	39.6	10.019	89.46	39.645	9.958	89.46	39.69

Table B.6a. Data Set 7: Covariance, 0.045° Incremental Angle.

Strip 1			Strip 2			Strip 3		
Range (m)	ϕ (°)	θ (°)	Range (m)	ϕ (°)	θ (°)	Range (m)	ϕ (°)	θ (°)
10.019	89.46	39.6	9.978	89.46	39.645	10.019	89.46	39.69
9.978	89.46	39.6	10.039	89.46	39.645	10.019	89.46	39.69
10.019	89.46	39.6	9.958	89.46	39.645	9.978	89.46	39.69
9.995	89.46	39.6	9.999	89.46	39.645	10.019	89.46	39.69
9.954	89.46	39.6	9.974	89.46	39.645	10.019	89.46	39.69
10.015	89.46	39.6	9.995	89.46	39.645	10.039	89.46	39.69
9.974	89.46	39.6	9.974	89.46	39.645	9.978	89.46	39.69
9.954	89.46	39.6	9.974	89.46	39.645	10.019	89.46	39.69
10.019	89.505	39.6	9.978	89.505	39.645	9.999	89.505	39.69
9.999	89.505	39.6	9.999	89.505	39.645	9.958	89.505	39.69
9.978	89.505	39.6	9.999	89.505	39.645	9.958	89.505	39.69
9.999	89.505	39.6	10.039	89.505	39.645	9.978	89.505	39.69
9.958	89.505	39.6	9.978	89.505	39.645	10.019	89.505	39.69
10.019	89.505	39.6	10.019	89.505	39.645	10.019	89.505	39.69
9.999	89.505	39.6	9.999	89.505	39.645	9.978	89.505	39.69
9.958	89.505	39.6	9.999	89.505	39.645	9.999	89.505	39.69
10.019	89.505	39.6	9.978	89.505	39.645	9.999	89.505	39.69
9.999	89.505	39.6	9.978	89.505	39.645	9.978	89.505	39.69
9.999	89.55	39.6	10.039	89.55	39.645	10.019	89.55	39.69
10.019	89.55	39.6	9.999	89.55	39.645	10.019	89.55	39.69
9.999	89.55	39.6	9.999	89.55	39.645	9.999	89.55	39.69
10.019	89.55	39.6	10.019	89.55	39.645	9.978	89.55	39.69
10.015	89.55	39.6	9.999	89.55	39.645	10.019	89.55	39.69
9.995	89.55	39.6	9.999	89.55	39.645	9.974	89.55	39.69
10.015	89.55	39.6	10.015	89.55	39.645	9.995	89.55	39.69
9.995	89.55	39.6	10.015	89.55	39.645	10.015	89.55	39.69
10.015	89.55	39.6	10.015	89.55	39.645	10.015	89.55	39.69
10.015	89.55	39.6	10.015	89.55	39.645	10.015	89.55	39.69
9.958	89.595	39.6	10.019	89.595	39.645	10.019	89.595	39.699
9.999	89.595	39.6	9.958	89.595	39.645	9.999	89.595	39.699
9.978	89.595	39.6	9.999	89.595	39.645	9.999	89.595	39.69
9.978	89.595	39.6	9.958	89.595	39.645	9.999	89.595	39.69
9.978	89.595	39.6	9.999	89.595	39.645	9.999	89.595	39.69
10.039	89.595	39.6	10.019	89.595	39.645	9.999	89.595	39.69
9.999	89.595	39.6	9.999	89.595	39.645	9.999	89.595	39.69
9.978	89.595	39.6	9.978	89.595	39.645	10.039	89.595	39.69
10.019	89.595	39.6	9.978	89.595	39.645	9.978	89.595	39.69
9.999	89.595	39.6	9.999	89.595	39.645	9.999	89.595	39.69
9.978	89.64	39.6	9.978	89.64	39.645	9.958	89.64	39.699
10.039	89.64	39.6	9.999	89.64	39.645	9.978	89.64	39.699
9.999	89.64	39.6	10.019	89.64	39.645	10.039	89.64	39.699
10.019	89.64	39.6	9.999	89.64	39.645	10.019	89.64	39.699
9.978	89.64	39.6	10.015	89.64	39.645	9.978	89.64	39.699
9.978	89.64	39.6	9.954	89.64	39.645	10.039	89.64	39.699
9.999	89.64	39.6	10.015	89.64	39.645	10.019	89.64	39.699
9.978	89.64	39.6	9.995	89.64	39.645	9.978	89.64	39.699
10.035	89.64	39.6	10.015	89.64	39.645	9.999	89.64	39.699
10.015	89.64	39.6	10.035	89.64	39.645	10.019	89.64	39.699
10.019	89.685	39.6	10.019	89.685	39.645	9.999	89.685	39.699
9.999	89.685	39.6	9.999	89.685	39.645	9.999	89.685	39.699

Table B.6a. Data Set 7: Covariance, 0.045° Incremental Angle.

Strip 1			Strip 2			Strip 3		
Range (m)	ϕ (°)	θ (°)	Range (m)	ϕ (°)	θ (°)	Range (m)	ϕ (°)	θ (°)
10.019	89.685	39.6	9.999	89.685	39.645	9.978	89.685	39.699
9.999	89.685	39.6	9.978	89.685	39.645	9.954	89.685	39.699
10.015	89.685	39.6	9.999	89.685	39.645	9.995	89.685	39.699
9.995	89.685	39.6	10.019	89.685	39.645	9.954	89.685	39.699
9.974	89.685	39.6	9.999	89.685	39.645	9.974	89.685	39.699
10.015	89.685	39.6	9.999	89.685	39.645	10.015	89.685	39.699
9.954	89.685	39.6	9.999	89.685	39.645	10.015	89.685	39.699
9.954	89.685	39.6	9.999	89.685	39.645	10.035	89.685	39.699
9.999	89.73	39.6	10.019	89.73	39.645	9.958	89.73	39.699
10.039	89.73	39.6	9.958	89.73	39.645	10.019	89.73	39.699
9.999	89.73	39.6	10.019	89.73	39.645	10.019	89.73	39.699
10.019	89.73	39.6	9.999	89.73	39.645	10.019	89.73	39.699
9.999	89.73	39.6	9.999	89.73	39.645	9.978	89.73	39.699
9.978	89.73	39.6	10.019	89.73	39.645	10.019	89.73	39.699
10.019	89.73	39.6	10.019	89.73	39.645	10.019	89.73	39.699
9.999	89.73	39.6	9.999	89.73	39.645	9.978	89.73	39.699
10.015	89.73	39.6	9.999	89.73	39.645	9.978	89.73	39.699
10.015	89.73	39.6	10.015	89.73	39.645	10.015	89.73	39.699
9.978	89.775	39.6	10.019	89.775	39.645	9.999	89.775	39.699
10.019	89.775	39.6	9.999	89.775	39.645	9.978	89.775	39.699
10.019	89.775	39.6	10.019	89.775	39.645	10.019	89.775	39.699
10.019	89.775	39.6	10.019	89.775	39.645	9.999	89.775	39.699
9.978	89.775	39.6	9.999	89.775	39.645	10.019	89.775	39.699
9.978	89.775	39.6	10.019	89.775	39.645	9.999	89.775	39.699
9.999	89.775	39.6	10.039	89.775	39.645	10.019	89.775	39.699
9.958	89.775	39.6	9.999	89.775	39.645	10.015	89.775	39.699
9.995	89.775	39.6	9.999	89.775	39.645	10.015	89.775	39.699
9.995	89.775	39.6	9.995	89.775	39.645	10.015	89.775	39.699
9.958	89.82	39.6	9.999	89.82	39.645	10.019	89.82	39.699
10.019	89.82	39.6	10.019	89.82	39.645	9.999	89.82	39.699
9.978	89.82	39.6	9.978	89.82	39.645	9.958	89.82	39.699
9.999	89.82	39.6	9.978	89.82	39.645	9.958	89.82	39.699
9.978	89.82	39.6	9.978	89.82	39.645	9.999	89.82	39.699
10.019	89.82	39.6	9.999	89.82	39.645	10.019	89.82	39.699
9.999	89.82	39.6	9.958	89.82	39.645	10.039	89.82	39.699
9.958	89.82	39.6	9.958	89.82	39.645	9.999	89.82	39.699
9.999	89.82	39.6	9.999	89.82	39.645	9.978	89.82	39.699
9.999	89.82	39.6	9.958	89.82	39.645	10.015	89.82	39.699
9.999	89.865	39.6	9.999	89.865	39.645	10.019	89.865	39.699
9.978	89.865	39.6	9.978	89.865	39.645	10.019	89.865	39.699
9.999	89.865	39.6	9.999	89.865	39.645	9.999	89.865	39.699
10.019	89.865	39.6	9.999	89.865	39.645	9.958	89.865	39.699
9.978	89.865	39.6	10.019	89.865	39.645	9.995	89.865	39.699
9.954	89.865	39.6	9.999	89.865	39.645	9.954	89.865	39.69
9.995	89.865	39.6	9.999	89.865	39.645	9.974	89.865	39.69
9.995	89.865	39.6	9.999	89.865	39.645	9.995	89.865	39.69
10.015	89.865	39.6	9.999	89.865	39.645	10.015	89.865	39.69
10.015	89.865	39.6	9.999	89.865	39.645	10.015	89.865	39.69
9.978	89.91	39.6	9.958	89.91	39.645	9.999	89.91	39.69
9.999	89.91	39.6	10.019	89.91	39.645	9.978	89.91	39.69

Table B.6a. Data Set 7: Covariance, 0.045° Incremental Angle.

Strip 1			Strip 2			Strip 3		
Range (m)	ϕ (°)	θ (°)	Range (m)	ϕ (°)	θ (°)	Range (m)	ϕ (°)	θ (°)
9.978	89.91	39.6	9.958	89.91	39.645	9.978	89.91	39.69
10.019	89.91	39.6	10.019	89.91	39.645	9.999	89.91	39.69
10.019	89.91	39.6	9.999	89.91	39.645	9.999	89.91	39.69
9.999	89.91	39.6	9.958	89.91	39.645	10.019	89.91	39.69
9.978	89.91	39.6	9.958	89.91	39.645	10.019	89.91	39.69
10.019	89.91	39.6	9.958	89.91	39.645	9.999	89.91	39.69
9.999	89.91	39.6	10.019	89.91	39.645	9.999	89.91	39.69
9.978	89.91	39.6	10.015	89.91	39.645	10.019	89.91	39.69
9.978	89.955	39.6	10.019	89.955	39.645	9.978	89.955	39.69
10.019	89.955	39.6	9.978	89.955	39.645	9.999	89.955	39.69
9.958	89.955	39.6	10.019	89.955	39.645	9.978	89.955	39.69
9.999	89.955	39.6	9.978	89.955	39.645	10.019	89.955	39.69
10.039	89.955	39.6	9.999	89.955	39.645	9.958	89.955	39.69
9.999	89.955	39.6	10.019	89.955	39.645	10.019	89.955	39.69
9.958	89.955	39.6	10.019	89.955	39.645	10.019	89.955	39.69
10.019	89.955	39.6	10.019	89.955	39.645	9.978	89.955	39.69
9.999	89.955	39.6	9.999	89.955	39.645	9.974	89.955	39.69
9.954	89.955	39.6	10.019	89.955	39.645	9.995	89.955	39.69
9.958	90	39.6	9.978	90	39.645	9.978	90	39.69
9.999	90	39.6	10.019	90	39.645	9.958	90	39.69
10.039	90	39.6	9.999	90	39.645	10.039	90	39.69
9.978	90	39.6	9.978	90	39.645	10.039	90	39.69
10.019	90	39.6	9.978	90	39.645	9.978	90	39.69
9.999	90	39.6	10.019	90	39.645	10.019	90	39.69
9.958	90	39.6	10.019	90	39.645	10.019	90	39.69
10.019	90	39.6	10.019	90	39.645	10.039	90	39.69
9.938	90	39.6	9.974	90	39.645	9.978	90	39.69
10.019	90	39.6	9.995	90	39.645	10.019	90	39.69
9.999	90.045	39.6	9.999	90.045	39.645	10.019	90.045	39.69
10.019	90.045	39.6	9.958	90.045	39.645	9.999	90.045	39.699
9.978	90.045	39.6	10.019	90.045	39.645	9.978	90.045	39.69
9.999	90.045	39.6	9.978	90.045	39.645	9.978	90.045	39.69
9.958	90.045	39.6	9.999	90.045	39.645	9.999	90.045	39.69
10.019	90.045	39.6	10.019	90.045	39.645	10.019	90.045	39.69
10.019	90.045	39.6	9.999	90.045	39.645	9.999	90.045	39.69
9.958	90.045	39.6	9.999	90.045	39.645	9.978	90.045	39.69
9.995	90.045	39.6	10.019	90.045	39.645	9.974	90.045	39.69
9.954	90.045	39.6	10.019	90.045	39.645	10.015	90.045	39.69
10.019	90.09	39.6	9.978	90.09	39.645	9.999	90.09	39.699
10.019	90.09	39.6	9.958	90.09	39.645	10.019	90.09	39.699
9.999	90.09	39.6	10.019	90.09	39.645	9.999	90.09	39.699
10.019	90.09	39.6	9.999	90.09	39.645	9.999	90.09	39.699
9.958	90.09	39.6	10.019	90.09	39.645	10.019	90.09	39.699
10.019	90.09	39.6	10.019	90.09	39.645	9.978	90.09	39.699
10.019	90.09	39.6	10.015	90.09	39.645	9.978	90.09	39.699
9.958	90.09	39.6	10.015	90.09	39.645	10.019	90.09	39.69
9.999	90.09	39.6	10.015	90.09	39.645	9.978	90.09	39.69
9.978	90.09	39.6	10.015	90.09	39.645	9.958	90.09	39.69
10.019	90.135	39.6	10.019	90.135	39.645	10.019	90.135	39.699
10.019	90.135	39.6	10.019	90.135	39.645	10.019	90.135	39.699

Table B.6a. Data Set 7: Covariance, 0.045° Incremental Angle.

Strip 1			Strip 2			Strip 3		
Range (m)	ϕ (°)	θ (°)	Range (m)	ϕ (°)	θ (°)	Range (m)	ϕ (°)	θ (°)
9.978	90.135	39.6	10.019	90.135	39.645	9.958	90.135	39.699
9.999	90.135	39.6	10.019	90.135	39.645	9.999	90.135	39.699
10.019	90.135	39.6	10.019	90.135	39.645	10.019	90.135	39.699
10.019	90.135	39.6	10.019	90.135	39.645	9.978	90.135	39.699
10.019	90.135	39.6	10.019	90.135	39.645	9.938	90.135	39.699
10.019	90.135	39.6	10.019	90.135	39.645	10.019	90.135	39.699
9.978	90.135	39.6	10.019	90.135	39.645	9.999	90.135	39.699
9.978	90.135	39.6	10.019	90.135	39.645	9.995	90.135	39.699
9.999	90.18	39.6	10.019	90.18	39.645	10.019	90.18	39.699
10.019	90.18	39.6	9.958	90.18	39.645	9.999	90.18	39.699
9.958	90.18	39.6	10.019	90.18	39.645	9.958	90.18	39.699
9.999	90.18	39.6	10.019	90.18	39.645	9.958	90.18	39.699
10.019	90.18	39.6	10.019	90.18	39.645	9.999	90.18	39.699
10.019	90.18	39.6	10.035	90.18	39.645	9.978	90.18	39.699
9.978	90.18	39.6	10.015	90.18	39.645	10.019	90.18	39.699
10.019	90.18	39.6	9.954	90.18	39.645	9.999	90.18	39.699
9.978	90.18	39.6	10.035	90.18	39.645	9.999	90.18	39.699
9.958	90.18	39.6	10.015	90.18	39.645	9.999	90.18	39.699
9.978	90.225	39.6	9.999	90.225	39.645	9.978	90.225	39.699
10.019	90.225	39.6	9.999	90.225	39.645	9.999	90.225	39.699
10.019	90.225	39.6	9.999	90.225	39.645	10.019	90.225	39.699
9.978	90.225	39.6	9.978	90.225	39.645	9.999	90.225	39.699
9.999	90.225	39.6	9.999	90.225	39.645	10.019	90.225	39.699
9.978	90.225	39.6	9.999	90.225	39.645	9.999	90.225	39.699
10.019	90.225	39.6	10.019	90.225	39.645	9.999	90.225	39.699
9.999	90.225	39.6	10.019	90.225	39.645	9.999	90.225	39.699
10.035	90.225	39.6	9.999	90.225	39.645	9.999	90.225	39.699
9.974	90.225	39.6	10.019	90.225	39.645	9.974	90.225	39.699
9.999	90.27	39.6	9.999	90.27	39.645	10.019	90.27	39.699
9.958	90.27	39.6	9.958	90.27	39.645	10.019	90.27	39.699
9.958	90.27	39.6	9.999	90.27	39.645	9.978	90.27	39.699
9.999	90.27	39.6	9.999	90.27	39.645	9.958	90.27	39.699
10.019	90.27	39.6	9.995	90.27	39.645	9.978	90.27	39.699
9.999	90.27	39.6	10.015	90.27	39.645	10.019	90.27	39.699
9.999	90.27	39.6	10.015	90.27	39.645	9.978	90.27	39.699
10.019	90.27	39.6	10.015	90.27	39.645	9.958	90.27	39.699
9.999	90.27	39.6	10.015	90.27	39.645	9.978	90.27	39.699
9.999	90.27	39.6	10.015	90.27	39.645	10.019	90.27	39.699
9.999	90.315	39.6	9.999	90.315	39.645	10.019	90.315	39.699
10.019	90.315	39.6	9.978	90.315	39.645	9.999	90.315	39.699
9.978	90.315	39.6	10.019	90.315	39.645	10.019	90.315	39.699
9.958	90.315	39.6	10.019	90.315	39.645	10.019	90.315	39.699
10.015	90.315	39.6	10.019	90.315	39.645	9.978	90.315	39.699
9.999	90.315	39.6	9.978	90.315	39.645	10.019	90.315	39.699
9.974	90.315	39.6	10.059	90.315	39.645	10.015	90.315	39.699
10.015	90.315	39.6	9.999	90.315	39.645	9.974	90.315	39.699
9.974	90.315	39.6	10.015	90.315	39.645	9.995	90.315	39.699
10.015	90.315	39.6	9.974	90.315	39.645	10.015	90.315	39.699
9.958	90.36	39.6	10.019	90.36	39.645	9.999	90.36	39.699
10.019	90.36	39.6	9.999	90.36	39.645	9.978	90.36	39.699

Table B.6a. Data Set 7: Covariance, 0.045° Incremental Angle.

Strip 1			Strip 2			Strip 3		
Range (m)	ϕ (°)	θ (°)	Range (m)	ϕ (°)	θ (°)	Range (m)	ϕ (°)	θ (°)
10.019	90.36	39.6	9.978	90.36	39.645	10.019	90.36	39.699
10.019	90.36	39.6	10.019	90.36	39.645	10.019	90.36	39.699
9.978	90.36	39.6	9.978	90.36	39.645	9.999	90.36	39.699
9.978	90.36	39.6	9.999	90.36	39.645	9.999	90.36	39.699
10.039	90.36	39.6	9.958	90.36	39.645	9.958	90.36	39.699
10.019	90.36	39.6	9.999	90.36	39.645	10.019	90.36	39.699
10.019	90.36	39.6	9.978	90.36	39.645	10.019	90.36	39.699
10.015	90.36	39.6	9.995	90.36	39.645	10.019	90.36	39.699
9.999	90.405	39.6	9.999	90.405	39.645	9.999	90.405	39.699
10.039	90.405	39.6	9.999	90.405	39.645	9.999	90.405	39.699
9.978	90.405	39.6	9.999	90.405	39.645	10.019	90.405	39.699
9.978	90.405	39.6	9.978	90.405	39.645	10.019	90.405	39.69
10.035	90.405	39.6	9.999	90.405	39.645	9.974	90.405	39.69
10.015	90.405	39.6	10.019	90.405	39.645	10.015	90.405	39.69
9.974	90.405	39.6	10.019	90.405	39.645	10.015	90.405	39.69
10.015	90.405	39.6	10.019	90.405	39.645	10.035	90.405	39.69
9.954	90.405	39.6	9.999	90.405	39.645	9.974	90.405	39.69
9.974	90.405	39.6	9.995	90.405	39.645	9.974	90.405	39.69
9.978	90.45	39.6	9.999	90.45	39.645	9.999	90.45	39.69
10.019	90.45	39.6	10.019	90.45	39.645	9.978	90.45	39.69
9.978	90.45	39.6	9.999	90.45	39.645	9.978	90.45	39.69
9.978	90.45	39.6	9.978	90.45	39.645	10.019	90.45	39.69
10.019	90.45	39.6	9.978	90.45	39.645	9.978	90.45	39.69
10.019	90.45	39.6	9.999	90.45	39.645	10.019	90.45	39.69
9.978	90.45	39.6	9.978	90.45	39.645	9.999	90.45	39.69
9.999	90.45	39.6	9.978	90.45	39.645	9.978	90.45	39.69
9.978	90.45	39.6	9.978	90.45	39.645	9.999	90.45	39.69
9.999	90.45	39.6	9.974	90.45	39.645	10.019	90.45	39.69
10.019	90.495	39.6	9.999	90.495	39.645	9.978	90.495	39.69
10.019	90.495	39.6	9.999	90.495	39.645	10.019	90.495	39.69
9.999	90.495	39.6	9.978	90.495	39.645	9.999	90.495	39.69
10.019	90.495	39.6	10.019	90.495	39.645	10.019	90.495	39.69
9.958	90.495	39.6	10.039	90.495	39.645	10.019	90.495	39.69
10.019	90.495	39.6	9.999	90.495	39.645	9.999	90.495	39.69
10.019	90.495	39.6	9.978	90.495	39.645	10.019	90.495	39.69
10.015	90.495	39.6	9.999	90.495	39.645	10.015	90.495	39.69
9.995	90.495	39.6	9.999	90.495	39.645	10.015	90.495	39.69
9.995	90.495	39.6	9.978	90.495	39.645	9.995	90.495	39.69
9.999	90.54	39.6	10.019	90.54	39.636	9.978	90.54	39.699
9.999	90.54	39.6	9.999	90.54	39.645	9.999	90.54	39.699
9.978	90.54	39.6	10.019	90.54	39.645	10.019	90.54	39.699
9.978	90.54	39.6	9.995	90.54	39.645	9.999	90.54	39.69
10.019	90.54	39.6	10.015	90.54	39.645	10.019	90.54	39.69
9.999	90.54	39.6	10.015	90.54	39.645	10.019	90.54	39.69
9.978	90.54	39.6	9.954	90.54	39.645	9.978	90.54	39.69
10.039	90.54	39.6	9.954	90.54	39.645	9.999	90.54	39.69
9.999	90.54	39.6	10.015	90.54	39.645	10.019	90.54	39.69
10.019	90.54	39.6	9.974	90.54	39.645	10.039	90.54	39.69

Table B.6b. Data Set 7: Covariance, 0.090° Incremental Angle.

Attic, Bldg. 226 File: dataset7_covariance_10m_090.xls
 Test date: Sept. 3, 2002

Strip 1			Strip 2			Strip 3		
Range (m)	ϕ (°)	θ (°)	Range (m)	ϕ (°)	θ (°)	Range (m)	ϕ (°)	θ (°)
10.015	88.92	39.6	10.035	88.92	39.69	10.03	88.92	39.78
9.995	88.92	39.6	9.995	88.92	39.69	9.969	88.92	39.78
10.015	88.92	39.6	10.035	88.92	39.69	10.01	88.92	39.78
9.974	88.92	39.6	10.01	88.92	39.69	9.989	88.92	39.78
9.989	88.92	39.6	10.03	88.92	39.69	9.989	88.92	39.78
10.01	88.92	39.6	10.03	88.92	39.69	9.969	88.92	39.78
10.01	88.92	39.6	10.03	88.92	39.69	9.969	88.92	39.78
9.969	88.92	39.6	10.03	88.92	39.69	9.989	88.92	39.78
9.969	88.92	39.6	10.01	88.92	39.69	10.01	88.92	39.78
10.01	88.92	39.6	10.03	88.92	39.69	9.969	88.92	39.78
9.974	89.01	39.6	10.015	89.01	39.69	9.995	89.01	39.78
10.035	89.01	39.6	10.015	89.01	39.69	10.015	89.01	39.78
10.035	89.01	39.6	9.974	89.01	39.69	10.035	89.01	39.78
9.974	89.01	39.6	10.015	89.01	39.69	9.974	89.01	39.78
9.995	89.01	39.6	10.015	89.01	39.69	10.015	89.01	39.78
9.974	89.01	39.6	10.015	89.01	39.69	10.035	89.01	39.78
9.974	89.01	39.6	10.01	89.01	39.69	10.015	89.01	39.78
9.989	89.01	39.6	10.01	89.01	39.69	10.01	89.01	39.78
10.01	89.01	39.6	10.01	89.01	39.69	9.989	89.01	39.78
10.01	89.01	39.6	9.989	89.01	39.69	10.01	89.01	39.78
9.974	89.1	39.6	9.954	89.1	39.69	10.015	89.1	39.78
10.015	89.1	39.6	9.989	89.1	39.69	10.015	89.1	39.78
9.974	89.1	39.6	9.969	89.1	39.69	10.035	89.1	39.78
9.995	89.1	39.6	10.01	89.1	39.69	10.035	89.1	39.78
9.995	89.1	39.6	10.01	89.1	39.69	10.015	89.1	39.78
10.015	89.1	39.6	9.969	89.1	39.69	10.035	89.1	39.78
10.015	89.1	39.6	9.969	89.1	39.69	10.015	89.1	39.78
10.01	89.1	39.6	10.01	89.1	39.69	9.995	89.1	39.78
10.01	89.1	39.6	9.969	89.1	39.69	9.995	89.1	39.78
10.01	89.1	39.6	10.01	89.1	39.69	10.03	89.1	39.78
10.015	89.19	39.6	10.015	89.19	39.69	9.995	89.19	39.78
9.974	89.19	39.6	9.995	89.19	39.69	9.995	89.19	39.78
10.015	89.19	39.6	9.974	89.19	39.69	10.015	89.19	39.78
9.974	89.19	39.6	9.995	89.19	39.69	10.015	89.19	39.78
10.015	89.19	39.6	10.015	89.19	39.69	10.015	89.19	39.78
10.015	89.19	39.6	10.015	89.19	39.69	10.035	89.19	39.78
10.015	89.19	39.6	10.01	89.19	39.69	10.015	89.19	39.78
9.974	89.19	39.6	9.969	89.19	39.69	10.01	89.19	39.78
9.969	89.19	39.6	10.01	89.19	39.69	9.989	89.19	39.78
9.969	89.19	39.6	9.989	89.19	39.69	10.01	89.19	39.78
9.995	89.28	39.6	10.035	89.28	39.69	10.015	89.28	39.78
10.015	89.28	39.6	10.015	89.28	39.69	10.015	89.28	39.78
10.015	89.28	39.6	10.015	89.28	39.69	9.995	89.28	39.78
10.035	89.28	39.6	10.015	89.28	39.69	9.995	89.28	39.78
10.015	89.28	39.6	10.015	89.28	39.69	10.015	89.28	39.78
10.015	89.28	39.6	10.015	89.28	39.69	10.015	89.28	39.78
9.995	89.28	39.6	9.995	89.28	39.69	10.035	89.28	39.78
10.015	89.28	39.6	10.015	89.28	39.69	9.989	89.28	39.78
10.01	89.28	39.6	10.01	89.28	39.69	9.995	89.28	39.78

Table B.6b. Data Set 7: Covariance, 0.090° Incremental Angle.

Strip 1			Strip 2			Strip 3		
Range (m)	ϕ (°)	θ (°)	Range (m)	ϕ (°)	θ (°)	Range (m)	ϕ (°)	θ (°)
9.969	89.28	39.6	10.01	89.28	39.69	9.995	89.28	39.78
9.995	89.37	39.6	9.974	89.37	39.69	10.015	89.37	39.78
9.995	89.37	39.6	10.015	89.37	39.69	9.974	89.37	39.78
10.015	89.37	39.6	10.015	89.37	39.69	9.974	89.37	39.78
10.055	89.37	39.6	10.015	89.37	39.69	9.974	89.37	39.78
10.035	89.37	39.6	10.01	89.37	39.69	10.015	89.37	39.78
10.035	89.37	39.6	9.969	89.37	39.69	10.015	89.37	39.78
9.974	89.37	39.6	9.969	89.37	39.69	10.035	89.37	39.78
10.035	89.37	39.6	10.01	89.37	39.69	10.015	89.37	39.78
10.015	89.37	39.6	9.989	89.37	39.69	9.995	89.37	39.78
9.989	89.37	39.6	10.01	89.37	39.69	10.01	89.37	39.78
10.015	89.46	39.6	10.035	89.46	39.69	10.015	89.46	39.78
10.015	89.46	39.6	9.954	89.46	39.69	10.015	89.46	39.78
9.954	89.46	39.6	10.035	89.46	39.69	9.974	89.46	39.78
10.015	89.46	39.6	10.015	89.46	39.69	9.974	89.46	39.78
10.035	89.46	39.6	9.989	89.46	39.69	10.035	89.46	39.78
10.015	89.46	39.6	9.989	89.46	39.69	10.015	89.46	39.78
10.015	89.46	39.6	10.03	89.46	39.69	10.015	89.46	39.78
9.974	89.46	39.6	9.989	89.46	39.69	10.015	89.46	39.78
9.995	89.46	39.6	10.01	89.46	39.69	9.995	89.46	39.78
10.055	89.46	39.6	9.989	89.46	39.69	9.995	89.46	39.78
9.995	89.55	39.6	10.035	89.55	39.69	10.015	89.55	39.78
10.015	89.55	39.6	10.015	89.55	39.69	10.035	89.55	39.78
10.035	89.55	39.6	9.974	89.55	39.69	10.035	89.55	39.78
9.974	89.55	39.6	9.995	89.55	39.69	10.015	89.55	39.78
10.015	89.55	39.6	9.995	89.55	39.69	10.015	89.55	39.78
10.015	89.55	39.6	9.974	89.55	39.69	9.974	89.55	39.78
10.015	89.55	39.6	10.01	89.55	39.69	9.974	89.55	39.78
10.015	89.55	39.6	10.01	89.55	39.69	10.035	89.55	39.78
10.035	89.55	39.6	9.949	89.55	39.69	10.015	89.55	39.78
10.01	89.55	39.6	10.03	89.55	39.69	9.974	89.55	39.78
10.015	89.64	39.6	10.055	89.64	39.69	10.015	89.64	39.78
10.035	89.64	39.6	10.015	89.64	39.69	10.015	89.64	39.78
10.015	89.64	39.6	9.995	89.64	39.69	10.015	89.64	39.78
9.974	89.64	39.6	10.015	89.64	39.69	10.015	89.64	39.78
9.974	89.64	39.6	9.974	89.64	39.69	9.974	89.64	39.78
9.974	89.64	39.6	9.995	89.64	39.69	10.015	89.64	39.78
9.974	89.64	39.6	9.974	89.64	39.69	9.974	89.64	39.78
10.01	89.64	39.6	10.015	89.64	39.69	10.03	89.64	39.78
10.01	89.64	39.6	10.015	89.64	39.69	10.03	89.64	39.78
10.01	89.64	39.6	9.969	89.64	39.69	9.969	89.64	39.78
10.035	89.73	39.6	10.015	89.73	39.69	10.015	89.73	39.78
10.015	89.73	39.6	10.015	89.73	39.69	9.995	89.73	39.78
10.015	89.73	39.6	10.035	89.73	39.69	10.015	89.73	39.78
9.989	89.73	39.6	10.015	89.73	39.69	10.015	89.73	39.78
9.974	89.73	39.6	9.995	89.73	39.69	9.989	89.73	39.78
10.01	89.73	39.6	9.974	89.73	39.69	9.995	89.73	39.78
10.01	89.73	39.6	9.974	89.73	39.69	9.969	89.73	39.78
10.01	89.73	39.6	10.01	89.73	39.69	9.969	89.73	39.78
10.01	89.73	39.6	10.03	89.73	39.69	10.03	89.73	39.78

Table B.6b. Data Set 7: Covariance, 0.090° Incremental Angle.

Strip 1			Strip 2			Strip 3		
Range (m)	ϕ (°)	θ (°)	Range (m)	ϕ (°)	θ (°)	Range (m)	ϕ (°)	θ (°)
10.01	89.73	39.6	10.01	89.73	39.69	9.969	89.73	39.78
10.015	89.82	39.6	9.974	89.82	39.69	10.015	89.82	39.78
10.015	89.82	39.6	9.954	89.82	39.69	9.995	89.82	39.78
10.015	89.82	39.6	10.015	89.82	39.69	10.015	89.82	39.78
10.015	89.82	39.6	9.974	89.82	39.69	10.015	89.82	39.78
9.974	89.82	39.6	10.015	89.82	39.69	10.015	89.82	39.78
9.989	89.82	39.6	9.995	89.82	39.69	9.969	89.82	39.78
9.969	89.82	39.6	10.01	89.82	39.69	9.969	89.82	39.78
10.01	89.82	39.6	9.969	89.82	39.69	10.01	89.82	39.78
10.01	89.82	39.6	10.01	89.82	39.69	10.01	89.82	39.78
10.01	89.82	39.6	9.989	89.82	39.69	10.01	89.82	39.78
9.995	89.91	39.6	9.995	89.91	39.69	9.954	89.91	39.78
9.974	89.91	39.6	9.995	89.91	39.69	10.015	89.91	39.78
9.974	89.91	39.6	9.995	89.91	39.69	9.989	89.91	39.78
10.015	89.91	39.6	10.035	89.91	39.69	10.03	89.91	39.78
9.989	89.91	39.6	9.949	89.91	39.69	10.03	89.91	39.78
10.01	89.91	39.6	9.989	89.91	39.69	9.974	89.91	39.78
9.989	89.91	39.6	9.969	89.91	39.69	9.969	89.91	39.78
10.01	89.91	39.6	10.01	89.91	39.69	10.01	89.91	39.78
10.01	89.91	39.6	9.989	89.91	39.69	10.03	89.91	39.78
10.01	89.91	39.6	9.969	89.91	39.69	10.03	89.91	39.78
9.995	90	39.6	9.974	90	39.69	10.015	90	39.78
10.035	90	39.6	9.969	90	39.69	10.015	90	39.78
9.995	90	39.6	9.974	90	39.69	10.015	90	39.78
10.01	90	39.6	10.01	90	39.69	10.01	90	39.78
9.989	90	39.6	9.989	90	39.69	10.015	90	39.78
9.989	90	39.6	9.989	90	39.69	10.01	90	39.78
10.01	90	39.6	9.969	90	39.69	9.989	90	39.78
10.01	90	39.6	10.01	90	39.69	9.989	90	39.78
10.01	90	39.6	9.969	90	39.69	10.01	90	39.78
10.03	90	39.6	10.03	90	39.69	9.969	90	39.78
10.015	90.09	39.6	9.995	90.09	39.69	10.015	90.09	39.78
9.995	90.09	39.6	10.015	90.09	39.69	10.015	90.09	39.78
9.954	90.09	39.6	10.015	90.09	39.69	9.974	90.09	39.78
10.015	90.09	39.6	10.015	90.09	39.69	9.969	90.09	39.78
10.01	90.09	39.6	9.989	90.09	39.69	10.01	90.09	39.78
10.03	90.09	39.6	9.989	90.09	39.69	10.01	90.09	39.78
10.01	90.09	39.6	10.01	90.09	39.69	10.01	90.09	39.78
9.969	90.09	39.6	9.949	90.09	39.69	10.01	90.09	39.78
9.969	90.09	39.6	9.969	90.09	39.69	10.01	90.09	39.78
9.989	90.09	39.6	10.01	90.09	39.69	10.01	90.09	39.78
10.015	90.18	39.6	10.015	90.18	39.69	9.995	90.18	39.78
9.974	90.18	39.6	10.015	90.18	39.69	9.995	90.18	39.78
9.995	90.18	39.6	10.015	90.18	39.69	10.015	90.18	39.78
9.974	90.18	39.6	10.015	90.18	39.69	10.015	90.18	39.78
9.969	90.18	39.6	9.969	90.18	39.69	9.989	90.18	39.78
9.969	90.18	39.6	9.969	90.18	39.69	9.969	90.18	39.78
9.989	90.18	39.6	10.01	90.18	39.69	9.969	90.18	39.78
10.01	90.18	39.6	10.01	90.18	39.69	9.969	90.18	39.78
10.03	90.18	39.6	10.05	90.18	39.69	9.969	90.18	39.78

Table B.6b. Data Set 7: Covariance, 0.090° Incremental Angle.

Strip 1			Strip 2			Strip 3		
Range (m)	ϕ (°)	θ (°)	Range (m)	ϕ (°)	θ (°)	Range (m)	ϕ (°)	θ (°)
10.01	90.18	39.6	10.03	90.18	39.69	9.989	90.18	39.78
10.015	90.27	39.6	9.954	90.27	39.69	9.974	90.27	39.78
10.015	90.27	39.6	9.995	90.27	39.69	10.035	90.27	39.78
10.035	90.27	39.6	9.954	90.27	39.69	9.974	90.27	39.78
9.995	90.27	39.6	9.995	90.27	39.69	9.995	90.27	39.78
9.995	90.27	39.6	10.015	90.27	39.69	10.015	90.27	39.78
10.015	90.27	39.6	9.995	90.27	39.69	9.995	90.27	39.78
10.015	90.27	39.6	10.015	90.27	39.69	10.015	90.27	39.78
10.03	90.27	39.6	9.974	90.27	39.69	10.015	90.27	39.78
9.969	90.27	39.6	9.969	90.27	39.69	9.989	90.27	39.78
9.969	90.27	39.6	10.03	90.27	39.69	10.01	90.27	39.78
10.015	90.36	39.6	9.954	90.36	39.69	10.015	90.36	39.78
10.015	90.36	39.6	10.035	90.36	39.69	10.015	90.36	39.78
10.015	90.36	39.6	10.015	90.36	39.69	9.974	90.36	39.78
9.995	90.36	39.6	10.015	90.36	39.69	10.015	90.36	39.78
10.015	90.36	39.6	9.974	90.36	39.69	10.015	90.36	39.78
10.015	90.36	39.6	9.974	90.36	39.69	10.015	90.36	39.78
10.035	90.36	39.6	9.989	90.36	39.69	10.015	90.36	39.78
9.974	90.36	39.6	10.01	90.36	39.69	10.015	90.36	39.78
10.01	90.36	39.6	9.969	90.36	39.69	9.969	90.36	39.78
10.01	90.36	39.6	9.969	90.36	39.69	9.969	90.36	39.78
9.974	90.45	39.6	10.015	90.45	39.69	9.974	90.45	39.78
10.015	90.45	39.6	10.015	90.45	39.69	9.974	90.45	39.78
10.015	90.45	39.6	10.015	90.45	39.69	9.974	90.45	39.78
10.015	90.45	39.6	9.974	90.45	39.69	9.954	90.45	39.78
10.015	90.45	39.6	9.995	90.45	39.69	10.015	90.45	39.78
10.015	90.45	39.6	10.035	90.45	39.69	10.015	90.45	39.78
10.015	90.45	39.6	9.974	90.45	39.69	10.01	90.45	39.78
10.01	90.45	39.6	10.015	90.45	39.69	10.01	90.45	39.78
9.969	90.45	39.6	9.995	90.45	39.69	9.969	90.45	39.78
10.01	90.45	39.6	9.969	90.45	39.69	9.989	90.45	39.78
10.015	90.54	39.6	10.015	90.54	39.69	10.015	90.54	39.78
10.015	90.54	39.6	10.015	90.54	39.69	9.995	90.54	39.78
9.995	90.54	39.6	10.015	90.54	39.69	9.995	90.54	39.78
9.974	90.54	39.6	9.974	90.54	39.69	9.995	90.54	39.78
10.015	90.54	39.6	10.035	90.54	39.69	10.015	90.54	39.78
10.035	90.54	39.6	10.035	90.54	39.69	10.015	90.54	39.78
10.015	90.54	39.6	9.974	90.54	39.69	10.015	90.54	39.78
9.995	90.54	39.6	10.055	90.54	39.69	10.01	90.54	39.78
9.969	90.54	39.6	9.974	90.54	39.69	9.969	90.54	39.78
9.969	90.54	39.6	10.015	90.54	39.69	10.03	90.54	39.78
10.015	90.63	39.6	10.015	90.63	39.69	10.015	90.63	39.78
9.974	90.63	39.6	9.995	90.63	39.69	10.015	90.63	39.78
10.015	90.63	39.6	10.015	90.63	39.69	10.015	90.63	39.78
9.974	90.63	39.6	9.995	90.63	39.69	9.995	90.63	39.78
9.974	90.63	39.6	10.015	90.63	39.69	9.969	90.63	39.78
9.969	90.63	39.6	9.995	90.63	39.69	10.03	90.63	39.78
9.969	90.63	39.6	10.015	90.63	39.69	10.01	90.63	39.78
9.989	90.63	39.6	9.974	90.63	39.69	10.03	90.63	39.78
10.01	90.63	39.6	9.995	90.63	39.69	10.03	90.63	39.78

Table B.6b. Data Set 7: Covariance, 0.090° Incremental Angle.

Strip 1			Strip 2			Strip 3		
Range (m)	ϕ (°)	θ (°)	Range (m)	ϕ (°)	θ (°)	Range (m)	ϕ (°)	θ (°)
10.03	90.63	39.6	9.995	90.63	39.69	10.01	90.63	39.78
10.015	90.72	39.6	9.995	90.72	39.69	9.954	90.72	39.78
9.995	90.72	39.6	9.974	90.72	39.69	10.015	90.72	39.78
10.035	90.72	39.6	9.974	90.72	39.69	10.015	90.72	39.78
10.015	90.72	39.6	9.974	90.72	39.69	10.015	90.72	39.78
10.015	90.72	39.6	10.015	90.72	39.69	9.995	90.72	39.78
10.015	90.72	39.6	10.035	90.72	39.69	9.974	90.72	39.78
9.995	90.72	39.6	9.974	90.72	39.69	9.974	90.72	39.78
9.995	90.72	39.6	10.015	90.72	39.69	9.974	90.72	39.78
9.974	90.72	39.6	10.035	90.72	39.69	10.035	90.72	39.78
10.05	90.72	39.6	10.015	90.72	39.69	9.974	90.72	39.78
9.954	90.81	39.6	10.015	90.81	39.69	9.995	90.81	39.78
10.015	90.81	39.6	10.015	90.81	39.69	10.015	90.81	39.78
9.969	90.81	39.6	10.035	90.81	39.69	10.055	90.81	39.78
10.01	90.81	39.6	9.995	90.81	39.69	9.989	90.81	39.78
10.01	90.81	39.6	9.995	90.81	39.69	10.01	90.81	39.78
10.01	90.81	39.6	9.995	90.81	39.69	10.01	90.81	39.78
10.01	90.81	39.6	10.015	90.81	39.69	9.989	90.81	39.78
10.01	90.81	39.6	9.974	90.81	39.69	9.969	90.81	39.78
10.03	90.81	39.6	9.954	90.81	39.69	9.969	90.81	39.78
9.969	90.81	39.6	9.989	90.81	39.69	9.969	90.81	39.78
10.015	90.9	39.6	10.015	90.9	39.69	9.995	90.9	39.78
10.035	90.9	39.6	9.995	90.9	39.69	10.015	90.9	39.78
10.015	90.9	39.6	10.015	90.9	39.69	9.974	90.9	39.78
9.995	90.9	39.6	10.035	90.9	39.69	10.055	90.9	39.78
9.989	90.9	39.6	9.974	90.9	39.69	10.015	90.9	39.78
9.989	90.9	39.6	9.974	90.9	39.69	10.01	90.9	39.78
9.989	90.9	39.6	9.974	90.9	39.69	9.989	90.9	39.78
10.03	90.9	39.6	10.015	90.9	39.69	10.01	90.9	39.78
10.01	90.9	39.6	10.035	90.9	39.69	10.03	90.9	39.78
10.01	90.9	39.6	10.015	90.9	39.69	9.989	90.9	39.78
10.015	90.99	39.6	10.035	90.99	39.69	9.995	90.99	39.78
9.995	90.99	39.6	10.015	90.99	39.69	9.995	90.99	39.78
10.01	90.99	39.6	9.974	90.99	39.69	9.974	90.99	39.78
10.01	90.99	39.6	9.969	90.99	39.69	9.989	90.99	39.78
10.01	90.99	39.6	10.015	90.99	39.69	10.03	90.99	39.78
9.989	90.99	39.6	10.015	90.99	39.69	10.01	90.99	39.78
9.969	90.99	39.6	9.969	90.99	39.69	10.01	90.99	39.78
9.989	90.99	39.6	10.01	90.99	39.69	9.989	90.99	39.78
9.969	90.99	39.6	10.01	90.99	39.69	10.01	90.99	39.78
9.989	90.99	39.6	10.01	90.99	39.69	10.01	90.99	39.78
10.015	91.08	39.6	10.015	91.08	39.69	10.015	91.08	39.78
10.015	91.08	39.6	9.995	91.08	39.69	9.974	91.08	39.78
10.01	91.08	39.6	9.989	91.08	39.69	10.055	91.08	39.78
9.969	91.08	39.6	9.989	91.08	39.69	10.01	91.08	39.78
9.989	91.08	39.6	10.01	91.08	39.69	10.03	91.08	39.78
9.969	91.08	39.6	10.01	91.08	39.69	10.01	91.08	39.78
9.989	91.08	39.6	10.01	91.08	39.69	9.989	91.08	39.78
10.01	91.08	39.6	10.01	91.08	39.69	9.989	91.08	39.78
10.01	91.08	39.6	10.01	91.08	39.69	10.03	91.08	39.78

Table B.6b. Data Set 7: Covariance, 0.090° Incremental Angle.

Strip 1			Strip 2			Strip 3		
Range (m)	ϕ (°)	θ (°)	Range (m)	ϕ (°)	θ (°)	Range (m)	ϕ (°)	θ (°)
9.969	91.08	39.6	10.01	91.08	39.69	10.03	91.08	39.78

Table B.6c. Data Set 7: Covariance, 0.180° Incremental Angle.

Strip 1			Strip 2			Strip 3		
Range (m)	ϕ (°)	θ (°)	Range (m)	ϕ (°)	θ (°)	Range (m)	ϕ (°)	θ (°)
10.01	87.84	39.6	10.01	87.84	39.789	10.03	87.84	39.951
10.01	87.84	39.6	10.01	87.84	39.789	10.03	87.84	39.951
10.03	87.84	39.6	10.03	87.84	39.789	10.01	87.84	39.951
10.03	87.84	39.6	9.969	87.84	39.789	10.01	87.84	39.951
10.03	87.84	39.6	9.969	87.84	39.789	10.03	87.84	39.951
9.989	87.84	39.6	10.01	87.84	39.789	10.03	87.84	39.951
10.025	87.84	39.6	10.01	87.84	39.789	10.01	87.84	39.951
10.005	87.84	39.6	10.01	87.84	39.789	9.989	87.84	39.951
10.045	87.84	39.6	10.03	87.84	39.789	9.969	87.84	39.951
10.025	87.84	39.6	9.989	87.84	39.789	9.969	87.84	39.951
9.969	88.02	39.6	10.01	88.02	39.78	10.03	88.02	39.96
10.03	88.02	39.6	10.01	88.02	39.78	10.03	88.02	39.96
10.01	88.02	39.6	10.03	88.02	39.78	10.03	88.02	39.96
9.989	88.02	39.6	9.989	88.02	39.78	10.03	88.02	39.96
10.03	88.02	39.6	9.989	88.02	39.78	10.05	88.02	39.96
10.03	88.02	39.6	9.989	88.02	39.789	10.03	88.02	39.96
10.025	88.02	39.6	10.03	88.02	39.789	9.989	88.02	39.96
9.989	88.02	39.6	10.03	88.02	39.789	10.05	88.02	39.96
10.005	88.02	39.6	9.989	88.02	39.789	10.005	88.02	39.96
10.025	88.02	39.6	10.03	88.02	39.789	10.005	88.02	39.96
10.05	88.2	39.6	10.01	88.2	39.78	10.01	88.2	39.951
10.03	88.2	39.6	10.01	88.2	39.78	10.03	88.2	39.951
9.989	88.2	39.6	10.01	88.2	39.78	10.03	88.2	39.96
10.05	88.2	39.6	10.01	88.2	39.78	10.03	88.2	39.951
10.05	88.2	39.6	10.03	88.2	39.78	9.969	88.2	39.951
10.03	88.2	39.6	10.03	88.2	39.789	10.01	88.2	39.951
10.01	88.2	39.6	9.969	88.2	39.789	10.01	88.2	39.951
10.01	88.2	39.6	10.045	88.2	39.789	10.05	88.2	39.951
10.01	88.2	39.6	10.025	88.2	39.789	9.984	88.2	39.951
10.005	88.2	39.6	9.984	88.2	39.789	10.045	88.2	39.96
10.05	88.38	39.6	9.989	88.38	39.78	10.03	88.38	39.96
10.01	88.38	39.6	10.05	88.38	39.78	10.01	88.38	39.96
10.03	88.38	39.6	10.03	88.38	39.78	10.05	88.38	39.96
10.01	88.38	39.6	10.03	88.38	39.78	10.01	88.38	39.96
10.01	88.38	39.6	10.03	88.38	39.78	10.03	88.38	39.96
9.969	88.38	39.6	10.03	88.38	39.78	9.984	88.38	39.96
10.025	88.38	39.6	10.01	88.38	39.78	10.025	88.38	39.96
10.005	88.38	39.6	10.03	88.38	39.78	9.984	88.38	39.96
10.005	88.38	39.6	10.025	88.38	39.78	9.964	88.38	39.96
10.005	88.38	39.6	10.005	88.38	39.78	10.005	88.38	39.96
10.01	88.56	39.6	9.969	88.56	39.78	10.05	88.56	39.96
9.989	88.56	39.6	9.989	88.56	39.78	10.01	88.56	39.96
10.01	88.56	39.6	9.969	88.56	39.78	10.01	88.56	39.96
10.03	88.56	39.6	10.01	88.56	39.78	10.01	88.56	39.96

Table B.6c. Data Set 7: Covariance, 0.180° Incremental Angle.

Strip 1			Strip 2			Strip 3		
Range (m)	ϕ (°)	θ (°)	Range (m)	ϕ (°)	θ (°)	Range (m)	ϕ (°)	θ (°)
9.989	88.56	39.6	10.03	88.56	39.78	10.01	88.56	39.96
10.01	88.56	39.6	10.03	88.56	39.78	10.01	88.56	39.96
10.03	88.56	39.6	10.01	88.56	39.78	9.989	88.56	39.96
10.01	88.56	39.6	10.03	88.56	39.78	10.01	88.56	39.96
9.989	88.56	39.6	10.03	88.56	39.78	10.05	88.56	39.96
9.964	88.56	39.6	10.01	88.56	39.78	10.025	88.56	39.96
10.01	88.74	39.6	9.969	88.74	39.78	9.969	88.74	39.951
9.989	88.74	39.6	9.969	88.74	39.78	10.03	88.74	39.951
10.03	88.74	39.6	10.01	88.74	39.78	9.989	88.74	39.96
10.03	88.74	39.6	9.989	88.74	39.78	9.969	88.74	39.951
10.03	88.74	39.6	9.989	88.74	39.789	10.03	88.74	39.951
9.989	88.74	39.6	9.989	88.74	39.789	10.03	88.74	39.951
10.01	88.74	39.6	10.01	88.74	39.789	10.01	88.74	39.951
9.989	88.74	39.6	10.05	88.74	39.789	10.03	88.74	39.951
9.969	88.74	39.6	10.01	88.74	39.789	10.03	88.74	39.96
10.03	88.74	39.6	9.989	88.74	39.789	10.01	88.74	39.96
10.03	88.92	39.6	10.03	88.92	39.789	10.01	88.92	39.951
10.03	88.92	39.6	9.969	88.92	39.789	9.989	88.92	39.951
10.01	88.92	39.6	10.01	88.92	39.789	10.01	88.92	39.951
10.03	88.92	39.6	9.969	88.92	39.789	10.05	88.92	39.951
10.01	88.92	39.6	10.01	88.92	39.789	10.05	88.92	39.951
10.05	88.92	39.6	9.989	88.92	39.789	9.969	88.92	39.951
9.989	88.92	39.6	10.01	88.92	39.789	9.989	88.92	39.951
10.01	88.92	39.6	10.01	88.92	39.789	10.03	88.92	39.951
10.01	88.92	39.6	10.05	88.92	39.789	10.05	88.92	39.951
9.989	88.92	39.6	9.969	88.92	39.789	10.03	88.92	39.951
9.989	89.1	39.6	10.01	89.1	39.789	9.969	89.1	39.96
10.01	89.1	39.6	10.03	89.1	39.789	9.969	89.1	39.96
10.01	89.1	39.6	9.989	89.1	39.789	10.01	89.1	39.96
10.03	89.1	39.6	10.01	89.1	39.789	10.01	89.1	39.96
10.01	89.1	39.6	10.03	89.1	39.789	10.01	89.1	39.96
9.969	89.1	39.6	9.969	89.1	39.789	10.01	89.1	39.96
10.03	89.1	39.6	10.01	89.1	39.789	10.01	89.1	39.96
10.025	89.1	39.6	10.05	89.1	39.789	9.989	89.1	39.96
10.01	89.1	39.6	9.969	89.1	39.789	9.969	89.1	39.96
10.03	89.1	39.6	10.03	89.1	39.789	9.969	89.1	39.96
10.01	89.28	39.6	9.989	89.28	39.789	10.01	89.28	39.96
9.969	89.28	39.6	10.01	89.28	39.789	9.989	89.28	39.96
10.03	89.28	39.6	10.01	89.28	39.789	10.03	89.28	39.96
10.01	89.28	39.6	9.989	89.28	39.789	10.05	89.28	39.96
10.05	89.28	39.6	10.03	89.28	39.789	10.01	89.28	39.96
9.969	89.28	39.6	10.03	89.28	39.789	10.03	89.28	39.96
10.01	89.28	39.6	10.01	89.28	39.789	10.01	89.28	39.96
10.03	89.28	39.6	10.01	89.28	39.789	9.989	89.28	39.96
10.05	89.28	39.6	10.03	89.28	39.789	10.01	89.28	39.96
9.964	89.28	39.6	10.01	89.28	39.789	9.984	89.28	39.96
10.01	89.46	39.6	9.969	89.46	39.789	9.969	89.46	39.96
10.01	89.46	39.6	10.01	89.46	39.789	10.03	89.46	39.96
10.01	89.46	39.6	10.01	89.46	39.789	10.01	89.46	39.96
10.01	89.46	39.6	10.03	89.46	39.789	10.01	89.46	39.96
10.01	89.46	39.6	10.01	89.46	39.789	9.969	89.46	39.96
9.969	89.46	39.6	10.01	89.46	39.789	9.989	89.46	39.96
10.01	89.46	39.6	10.03	89.46	39.789	10.005	89.46	39.96
10.025	89.46	39.6	10.01	89.46	39.789	10.025	89.46	39.96

Table B.6c. Data Set 7: Covariance, 0.180° Incremental Angle.

Strip 1			Strip 2			Strip 3		
Range (m)	ϕ (°)	θ (°)	Range (m)	ϕ (°)	θ (°)	Range (m)	ϕ (°)	θ (°)
10.03	89.46	39.6	10.01	89.46	39.789	10.025	89.46	39.96
10.025	89.46	39.6	10.045	89.46	39.789	10.025	89.46	39.96
10.01	89.64	39.6	9.969	89.64	39.789	9.989	89.64	39.96
10.03	89.64	39.6	10.01	89.64	39.789	9.969	89.64	39.96
10.03	89.64	39.6	9.989	89.64	39.789	10.01	89.64	39.96
10.03	89.64	39.6	10.01	89.64	39.789	10.01	89.64	39.96
10.03	89.64	39.6	10.01	89.64	39.789	10.01	89.64	39.96
10.03	89.64	39.6	10.03	89.64	39.789	10.01	89.64	39.96
10.01	89.64	39.6	9.969	89.64	39.789	9.989	89.64	39.96
10.01	89.64	39.6	10.01	89.64	39.789	10.005	89.64	39.96
10.01	89.64	39.6	10.01	89.64	39.789	10.005	89.64	39.96
10.005	89.64	39.6	10.01	89.64	39.789	10.005	89.64	39.96
9.969	89.82	39.6	9.969	89.82	39.789	10.01	89.82	39.96
10.03	89.82	39.6	10.01	89.82	39.789	9.969	89.82	39.96
10.01	89.82	39.6	10.01	89.82	39.789	10.01	89.82	39.96
10.01	89.82	39.6	9.969	89.82	39.789	10.01	89.82	39.96
10.01	89.82	39.6	10.01	89.82	39.789	9.989	89.82	39.96
10.05	89.82	39.6	9.989	89.82	39.789	10.03	89.82	39.96
9.989	89.82	39.6	10.01	89.82	39.789	9.989	89.82	39.96
10.01	89.82	39.6	10.01	89.82	39.789	10.01	89.82	39.96
10.05	89.82	39.6	10.01	89.82	39.789	9.969	89.82	39.96
10.03	89.82	39.6	10.03	89.82	39.789	10.05	89.82	39.96
10.03	90	39.6	10.03	90	39.78	10.05	90	39.96
10.01	90	39.6	10.01	90	39.789	10.01	90	39.96
10.01	90	39.6	10.03	90	39.78	9.989	90	39.96
10.01	90	39.6	9.969	90	39.78	10.03	90	39.96
10.01	90	39.6	10.01	90	39.789	10.01	90	39.96
9.969	90	39.6	10.01	90	39.789	10.01	90	39.96
10.01	90	39.6	10.01	90	39.789	10.01	90	39.96
10.01	90	39.6	9.969	90	39.789	9.969	90	39.96
9.989	90	39.6	9.989	90	39.789	9.969	90	39.96
10.045	90	39.6	9.969	90	39.78	10.045	90	39.96
10.03	90.18	39.6	9.969	90.18	39.78	9.989	90.18	39.96
10.01	90.18	39.6	10.01	90.18	39.78	10.01	90.18	39.96
9.989	90.18	39.6	9.969	90.18	39.78	9.969	90.18	39.96
9.969	90.18	39.6	10.01	90.18	39.78	10.01	90.18	39.96
9.969	90.18	39.6	9.969	90.18	39.78	9.989	90.18	39.96
10.03	90.18	39.6	10.01	90.18	39.78	10.01	90.18	39.96
9.969	90.18	39.6	10.01	90.18	39.78	10.01	90.18	39.96
10.03	90.18	39.6	10.01	90.18	39.78	10.01	90.18	39.96
10.01	90.18	39.6	9.969	90.18	39.78	9.969	90.18	39.96
10.01	90.18	39.6	10.005	90.18	39.78	10.025	90.18	39.96
9.989	90.36	39.6	9.969	90.36	39.78	10.01	90.36	39.96
10.01	90.36	39.6	10.01	90.36	39.78	9.989	90.36	39.96
9.969	90.36	39.6	9.989	90.36	39.78	10.01	90.36	39.96
9.989	90.36	39.6	10.01	90.36	39.78	9.989	90.36	39.96
10.03	90.36	39.6	10.03	90.36	39.78	10.01	90.36	39.96
9.989	90.36	39.6	9.989	90.36	39.78	9.969	90.36	39.96
10.01	90.36	39.6	9.989	90.36	39.789	9.969	90.36	39.96
10.03	90.36	39.6	9.964	90.36	39.78	10.01	90.36	39.96
10.01	90.36	39.6	9.964	90.36	39.789	10.025	90.36	39.96
10.01	90.36	39.6	10.025	90.36	39.78	10.025	90.36	39.96
10.05	90.54	39.6	10.01	90.54	39.78	10.01	90.54	39.96
10.03	90.54	39.6	10.01	90.54	39.78	10.01	90.54	39.96

Table B.6c. Data Set 7: Covariance, 0.180° Incremental Angle.

Strip 1			Strip 2			Strip 3		
Range (m)	ϕ (°)	θ (°)	Range (m)	ϕ (°)	θ (°)	Range (m)	ϕ (°)	θ (°)
10.01	90.54	39.6	10.01	90.54	39.78	9.989	90.54	39.96
10.01	90.54	39.6	10.01	90.54	39.78	10.01	90.54	39.96
9.969	90.54	39.6	10.03	90.54	39.78	10.01	90.54	39.96
10.03	90.54	39.6	10.01	90.54	39.789	9.989	90.54	39.96
9.969	90.54	39.6	9.969	90.54	39.789	9.989	90.54	39.96
9.969	90.54	39.6	10.025	90.54	39.789	9.989	90.54	39.96
9.989	90.54	39.6	10.005	90.54	39.789	10.01	90.54	39.96
10.03	90.54	39.6	9.984	90.54	39.789	10.03	90.54	39.96
9.969	90.72	39.6	10.03	90.72	39.78	9.969	90.72	39.96
10.03	90.72	39.6	9.969	90.72	39.78	10.01	90.72	39.96
10.03	90.72	39.6	10.01	90.72	39.78	9.969	90.72	39.96
10.01	90.72	39.6	9.969	90.72	39.78	9.969	90.72	39.96
9.989	90.72	39.6	10.01	90.72	39.78	10.01	90.72	39.96
10.01	90.72	39.6	10.01	90.72	39.78	10.01	90.72	39.96
9.989	90.72	39.6	9.969	90.72	39.78	10.01	90.72	39.96
10.01	90.72	39.6	9.984	90.72	39.78	10.01	90.72	39.96
10.05	90.72	39.6	10.03	90.72	39.78	10.01	90.72	39.96
10.03	90.72	39.6	9.989	90.72	39.78	10.01	90.72	39.96
9.969	90.9	39.6	10.01	90.9	39.78	9.989	90.9	39.96
9.969	90.9	39.6	10.01	90.9	39.78	9.969	90.9	39.96
9.989	90.9	39.6	10.03	90.9	39.78	10.01	90.9	39.96
10.03	90.9	39.6	9.989	90.9	39.78	10.03	90.9	39.96
10.01	90.9	39.6	10.01	90.9	39.78	9.969	90.9	39.96
9.969	90.9	39.6	9.989	90.9	39.78	9.989	90.9	39.96
10.03	90.9	39.6	10.03	90.9	39.78	10.01	90.9	39.96
10.03	90.9	39.6	9.969	90.9	39.78	9.989	90.9	39.96
10.03	90.9	39.6	9.989	90.9	39.78	10.03	90.9	39.96
10.05	90.9	39.6	9.969	90.9	39.78	10.01	90.9	39.96
10.03	91.08	39.6	10.05	91.08	39.78	10.01	91.08	39.96
10.03	91.08	39.6	9.969	91.08	39.78	10.03	91.08	39.96
9.989	91.08	39.6	9.989	91.08	39.78	10.01	91.08	39.96
10.01	91.08	39.6	10.05	91.08	39.78	10.01	91.08	39.96
10.05	91.08	39.6	9.989	91.08	39.78	9.989	91.08	39.96
10.01	91.08	39.6	9.989	91.08	39.78	10.03	91.08	39.96
10.05	91.08	39.6	10.01	91.08	39.78	10.05	91.08	39.96
10.01	91.08	39.6	9.989	91.08	39.78	9.989	91.08	39.96
9.989	91.08	39.6	10.01	91.08	39.78	10.03	91.08	39.96
10.01	91.08	39.6	10.03	91.08	39.78	10.01	91.08	39.96
10.01	91.26	39.6	10.01	91.26	39.78	9.969	91.26	39.96
10.03	91.26	39.6	10.01	91.26	39.78	10.03	91.26	39.96
10.01	91.26	39.6	9.969	91.26	39.78	10.03	91.26	39.96
10.03	91.26	39.6	10.01	91.26	39.78	10.03	91.26	39.96
9.969	91.26	39.6	9.989	91.26	39.78	9.989	91.26	39.96
10.01	91.26	39.6	10.01	91.26	39.789	10.01	91.26	39.96
10.03	91.26	39.6	10.03	91.26	39.789	9.989	91.26	39.96
10.01	91.26	39.6	9.989	91.26	39.789	9.989	91.26	39.96
10.01	91.26	39.6	10.01	91.26	39.789	9.969	91.26	39.96
10.01	91.26	39.6	10.01	91.26	39.789	10.01	91.26	39.96
10.01	91.44	39.6	10.03	91.44	39.789	10.01	91.44	39.96
10.01	91.44	39.6	9.989	91.44	39.789	9.969	91.44	39.96
10.03	91.44	39.6	10.03	91.44	39.789	10.01	91.44	39.96
10.01	91.44	39.6	10.01	91.44	39.789	10.01	91.44	39.96
10.05	91.44	39.6	9.969	91.44	39.789	10.01	91.44	39.96
10.01	91.44	39.6	9.969	91.44	39.789	10.03	91.44	39.96

Table B.6c. Data Set 7: Covariance, 0.180° Incremental Angle.

Strip 1			Strip 2			Strip 3		
Range (m)	ϕ (°)	θ (°)	Range (m)	ϕ (°)	θ (°)	Range (m)	ϕ (°)	θ (°)
9.969	91.44	39.6	10.03	91.44	39.789	10.01	91.44	39.96
9.989	91.44	39.6	10.01	91.44	39.789	10.03	91.44	39.96
9.969	91.44	39.6	9.969	91.44	39.789	10.05	91.44	39.96
10.03	91.44	39.6	10.05	91.44	39.789	9.969	91.44	39.96
10.01	91.62	39.6	10.01	91.62	39.78	10.05	91.62	39.96
9.969	91.62	39.6	9.989	91.62	39.78	9.969	91.62	39.96
10.01	91.62	39.6	10.01	91.62	39.78	9.969	91.62	39.96
10.03	91.62	39.6	9.989	91.62	39.78	10.01	91.62	39.96
10.01	91.62	39.6	10.05	91.62	39.78	10.01	91.62	39.96
10.01	91.62	39.6	9.969	91.62	39.78	9.989	91.62	39.96
9.989	91.62	39.6	10.03	91.62	39.78	10.03	91.62	39.96
10.03	91.62	39.6	10.01	91.62	39.78	10.01	91.62	39.96
10.045	91.62	39.6	10.03	91.62	39.78	10.03	91.62	39.96
10.005	91.62	39.6	10.005	91.62	39.78	9.984	91.62	39.96
10.03	91.8	39.6	10.01	91.8	39.78	10.01	91.8	39.96
10.01	91.8	39.6	10.05	91.8	39.78	10.01	91.8	39.96
10.03	91.8	39.6	9.969	91.8	39.78	10.05	91.8	39.96
10.03	91.8	39.6	10.05	91.8	39.78	9.989	91.8	39.96
9.989	91.8	39.6	9.969	91.8	39.78	10.01	91.8	39.96
10.03	91.8	39.6	10.01	91.8	39.78	10.03	91.8	39.96
10.01	91.8	39.6	10.025	91.8	39.78	10.03	91.8	39.96
10.01	91.8	39.6	10.045	91.8	39.78	10.01	91.8	39.96
9.989	91.8	39.6	10.005	91.8	39.78	10.01	91.8	39.96
10.05	91.8	39.6	10.045	91.8	39.78	9.989	91.8	39.96
10.01	91.98	39.6	10.03	91.98	39.789	10.01	91.98	39.96
10.01	91.98	39.6	10.05	91.98	39.789	9.969	91.98	39.96
10.03	91.98	39.6	9.989	91.98	39.789	10.01	91.98	39.96
10.01	91.98	39.6	10.03	91.98	39.789	10.01	91.98	39.96
10.01	91.98	39.6	9.969	91.98	39.789	10.01	91.98	39.96
10.01	91.98	39.6	9.984	91.98	39.789	10.01	91.98	39.96
10.01	91.98	39.6	10.005	91.98	39.789	10.005	91.98	39.96
10.03	91.98	39.6	10.045	91.98	39.789	9.984	91.98	39.96
9.964	91.98	39.6	9.984	91.98	39.789	10.025	91.98	39.96
10.005	91.98	39.6	10.045	91.98	39.789	10.025	91.98	39.96
10.03	92.16	39.6	10.03	92.16	39.78	9.969	92.16	39.96
10.01	92.16	39.6	10.01	92.16	39.78	10.01	92.16	39.96
10.01	92.16	39.6	10.01	92.16	39.78	10.05	92.16	39.96
10.03	92.16	39.6	10.03	92.16	39.78	9.989	92.16	39.96
9.989	92.16	39.6	10.05	92.16	39.78	10.03	92.16	39.96
10.01	92.16	39.6	10.005	92.16	39.78	10.03	92.16	39.96
9.989	92.16	39.6	10.005	92.16	39.78	9.989	92.16	39.96
10.01	92.16	39.6	10.005	92.16	39.78	9.989	92.16	39.96
10.05	92.16	39.6	9.964	92.16	39.78	10.025	92.16	39.96
9.964	92.16	39.6	10.025	92.16	39.78	10.01	92.16	39.96

Table B.7. Data Set 8- Autocorrelation, 100 points

File: 100pts.txt				
Col.1	Col. 2	Col. 3	Col. 4	Col. 5
Distances	Continued from Col. 1	Continued from Col. 2	Continued from Col. 3	Continued from Col. 4
(m)	(m)	(m)	(m)	(m)
19.957	19.992	19.972	19.992	20.012
19.997	19.992	19.972	19.992	19.988
19.977	19.992	19.972	19.992	19.988
20.017	20.012	20.012	19.992	19.988
20.017	20.012	19.992	19.972	19.988
19.997	19.992	20.012	19.992	20.012
19.997	19.992	19.952	20.008	19.988
19.977	19.972	20.012	19.972	19.968
20.017	19.972	19.992	19.988	20.008
19.997	19.992	19.972	19.968	19.988
19.997	20.012	19.952	20.012	19.948
19.997	19.992	20.012	20.012	19.998
19.977	19.972	19.972	19.972	19.988
19.997	19.992	19.992	19.992	20.008
20.017	20.012	19.992	20.008	19.988
19.997	19.992	20.012	19.988	19.968
19.952	20.012	20.012	20.008	20.008
19.972	19.972	19.972	19.992	19.948
19.992	19.972	19.992	19.968	19.988
19.992	20.012	20.008	20.008	19.988