

**Development of a Dynamic Compression Test
Apparatus for Measuring Thermal Performance
of Fire Fighters' Protective Clothing**

J. Randall Lawson
William H. Twilley
Building and Fire Research Laboratory
National Institute of Standards and Technology
Gaithersburg, MD 20899-8641

and

Kevin S. Malley
New York City Fire Department

Prepared for:
**Federal Emergency Management Agency
United States Fire Administration**



National Institute of Standards and Technology
Technology Administration, U.S. Department of Commerce

Development of a Dynamic Compression Test Apparatus for Measuring Thermal Performance of Fire Fighters' Protective Clothing

J. Randall Lawson
William H. Twilley
Building and Fire Research Laboratory
National Institute of Standards and Technology
Gaithersburg, MD 20899-8641

and

Kevin S. Malley
New York City Fire Department

April 2000



U. S. Department of Commerce

William M. Daley, Secretary

Technology Administration

Dr. Cheryl L. Shavers, Under Secretary of Commerce for Technology

National Institute of Standards and Technology

Raymond G. Kammer, Director



Federal Emergency Management Agency

James Lee Witt, Director

U.S. Fire Administration

Carrye B. Brown, Administrator

TABLE OF CONTENTS

Abstract	1
1.0 INTRODUCTION	2
2.0 CONCEPT	3
3.0 FIRE FIGHTER MEASUREMENTS	4
4.0 TEST APPARATUS	5
4.1 DEVELOPMENTAL HISTORY	5
4.2 APPARATUS DESCRIPTION	6
4.2.1 COMPRESSION SYSTEM	6
4.2.2 HOT WATER SYSTEM	7
4.2.3 HOT PLATE	8
4.2.4 SPECIMEN HOLDER	8
4.2.5 TEST SENSORS	9
4.2.6 DATA ACQUISITION SYSTEM	9
4.2.7 LABORATORY BALANCE	9
5.0 TEST SPECIMENS	10
5.1 DESCRIPTION	10
5.2 CONDITIONING	10
6.0 EXPERIMENTAL PROCEDURE	10
6.1 WET TEST PROCEDURE	11
6.2 DRY TEST PROCEDURE	12
7.0 PRECISION	12
8.0 EXAMPLES OF TEST DATA	13
8.1 WET TEST DATA	14
8.2 DRY TEST DATA	14
8.3 DISCUSSION	14
9.0 SUMMARY	15
10.0 ACKNOWLEDGEMENTS	15
11.0 REFERENCES	16
APPENDIX	A1

LIST OF FIGURES

Figure 1	Examples of fire fighter's knee prints, shown actual size.....	18
Figure 2	Concept apparatus for wet knee pad compression testing.....	18
Figure 3	Second generation compression test apparatus.....	19
Figure 4	Test apparatus as described in this report.....	19
Figure 5	Knee pad specimen prepared for testing.....	20
Figure 6	Compression apparatus specimen assembly prepared for wet testing.....	20
Figure 7	Apparatus during wet compression testing.....	21
Figure 8	Compression apparatus prepared for dry hot surface testing.....	21
Figure 9	Examples of test specimens used during apparatus development.....	22
Figure 10	Comparison of protective clothing compressed and uncompressed.....	22
Figure 11	Example of data taken from a wet compression test.....	23
Figure 12	Wet compression test data for six different knee pad designs.....	23
Figure 13	Garment and knee pad construction with temperature measurement locations.....	24
Figure 14	Dry compression test data for six different knee pad designs.....	24

Development of a Dynamic Compression Test Apparatus for Measuring The Thermal Performance of Fire Fighters' Protective Clothing

By

J. Randall Lawson, William H. Twilley, Kevin S. Malley

Abstract

A dynamic compression test apparatus has been developed that bases its design on fire ground conditions that produce burn injuries to the knees of fire fighters. This apparatus may be used to measure the thermal performance of fire fighters' protective clothing in either wet or dry thermal environments. Studies conducted by the New York City Fire Department (FDNY) show that the contact surface area of the human knee is approximately 3710 mm^2 (5.75 in^2) for a male fire fighter with a body mass of about 79 kg (174 lbs). In addition, the FDNY shows that a fully equipped 79 kg (174 lb) fire fighter operating a charged 44.5 mm ($1\frac{3}{4}$ in) hoseline had a mean average knee compression, force per unit area, of 133 kPa (19.3 lbf/in^2). The test apparatus and operating procedures discussed in this report take these data into consideration. The test apparatus uses a timer controlled pneumatic piston to compress the thermal sensor against the test specimen. Test results show that the compression apparatus can discriminate between various levels of thermal performance for fire fighters' protective clothing knee pad systems. In addition, results from the apparatus show that knee pad systems can have significantly different thermal performance when exposed to wet and dry thermal conditions.

KEY WORDS: Environments, fires, fire fighters, heat transfer, burns (injuries), protective clothing, test method

1.0 INTRODUCTION

More than five thousand fire fighters are seriously burned each year [1]. Of these, burn injuries to the legs and feet are the fourth most common type of injury [2]. Many of these burn injuries result from fire fighters crawling or kneeling in hot liquids or on hot surfaces. Even though these injuries comprise a relatively small fraction of the reported injuries sustained, these burns can have a significant affect on a fire fighters health, safety, and job performance. The ability of a fire fighter to move freely while conducting search and rescue activities or fire suppression operations directly affects their personal safety. Experience has shown that burn injuries to the knees can impair the movement of a fire fighter. In addition, these types of burn injuries are relatively common with engine company hose teams as they crawl through hot water. This is shown from New York City Fire Department (FDNY) burn injury data [3]. Hot water is developed when hose streams, used for fire suppression, are heated by the fire's atmosphere and/or fire heated structural surfaces and furnishings. Members of truck companies may also sustain burn injuries to the knees while crawling on dry hot floors during search and rescue operations. Or, they may be burned on the knee when kneeling on a hot roof while attempting to vent a structure. Data from FDNY studies indicate that dry environment or dry protective clothing knee burn injuries are not as common as those found with wet thermal exposures [3]. FDNY burn injury data accumulated over a 12 month period, during 1997 and 1998, shows that 27 fire fighters received knee burn injuries serious enough to result in medical leave ranging from 12 days to 248 days. Of these burn injuries, 11 fire fighters suffered burns requiring skin grafts. These data from FDNY also show that 25 of the 26 fire fighters interviewed in the study were members of an engine company. Of these 26 fire fighters, 21 were operating the hose line nozzle, 4 were backup on the hose line, and one was a truck company fire fighter [3].

Fire fighters' protective clothing has been designed to give the wearer a limited amount of protection from burn injury when exposed to a sudden flash fire or short duration exposure to a flashover condition. The National Fire Protection Association standard NFPA 1971 [4] has advanced the development of fire fighters' protective clothing and has made this level of protection possible. In addition, American industry has developed new materials and product designs that have improved the protection of fire fighters in these thermal exposures. However, the thermal performance of compressed protective clothing systems has not been addressed by the current standards. Work is currently underway on the NFPA 1971 committee to develop methods for measuring the thermal performance of compressed protective clothing systems. This work has primarily been directed at using a modified version of an American Society for Testing and Materials procedure, ASTM F1060, Standard Test Method for Thermal Protective Performance of Materials for Protective Clothing for Hot Surface Contact [5]. This procedure is a dry garment static compression test method, and it does not take into consideration, wet conditions or movement of the fire fighter.

NIST has been working with the New York City Fire Department in an effort to better understand the affects of fire fighters' protective clothing under compression. This study took advantage of the extensive fire ground experience possessed by FDNY. Using this knowledge as a base, NIST and FDNY developed a dynamic compression test method that may be used for studying the thermal performance of fire fighters' protective clothing over a range of fire fighting conditions. This test method may be used for studying protective clothing systems in either dry

or wet conditions. Test times may be for only a few seconds or the test time may be extended for a period that equals the time for a fire fighter to consume a complete bottle of air from a Self-Contained Breathing Apparatus (SCBA). At present, there is no maximum time limit for use of the apparatus.

2.0 CONCEPT

From the introduction, it may be seen that burn injuries to the knee may result from at least two significantly different thermal exposure conditions. One condition results from the knee coming into contact with flowing or pooled hot water on the floor of a burning structure. The second condition results from knee contact with a hot dry surface, i.e. floor or roof. These two conditions, depending on the protective clothing design, may produce two different types of heat transfer. Garments that become wet may exhibit significantly different levels of thermal protection as compared to dry garments. When a compressed protective garment is wet throughout, it would be expected to transfer heat at a much higher rate than a dry garment [6]. Water transfers heat about 21 times the rate of air at a temperature of 93 °C (200 °F) [7], and thermal protective garments use air space as a design component for reducing heat transfer. This concept is demonstrated when cooking with a hot cast iron handled frying pan. With a properly designed and constructed dry potholder an individual should be able to move the hot frying pan without the hand getting burned. If the same potholder gets wet, water will be absorbed by the low-density insulating fibers and may also fill the air space between the fibers. When a person attempts to move the same hot frying pan with the wet potholder, compression causes an increase in material density and decreases any remaining insulating air space. Then water becomes a significant element for transferring heat through the potholder. As a result, heat is transferred through the wet potholder at a much higher rate, and the individual may feel pain and receive a burn injury [8]. This case is similar to what may happen when a fire fighter's kneepad gets wet and heat suddenly flows through the protective garment.

The second case is also related to the potholder example. However, in this case the protective clothing garment system remains dry when it is exposed to a hot dry surface. With this type of exposure, factors that control heat flow through the potholder are its thermal properties and the degree of compression or loss of air space. Therefore, measuring the thermal performance of dry protective clothing systems appears to be less complicated. This may be the case until hot surface thermal exposures reach levels high enough to cause decomposition of the protective clothing materials. When material decomposition begins heat transfer processes become much more complicated. This report does not address heat transfer processes where protective clothing material decomposition takes place. In addition, this report does not address two other types of thermal exposures that lead to burn injuries. One of these thermal exposures occurs from direct contact with hot gases or flames, and the other thermal exposure results from radiant heat energy generated by a fire. A separate report is being prepared that addresses thermal performance issues related to these types of thermal exposures.

As shown in the above discussion, both wet and dry thermal exposures are important to the design of fire fighters' protective clothing. Designing protective clothing for maximum thermal performance in a dry fire fighting environment may have a negative impact on a garment's maximum thermal performance in a wet fire fighting environment. For optimum thermal

performance of fire fighters' protective clothing, garments must be designed for both wet and dry fire fighting conditions. The test apparatus described in this report may be used for measuring the thermal performance of protective clothing systems when being exposed to wet thermal conditions or dry thermal conditions. In addition, the test apparatus was designed to measure thermal performance under dynamic compression.

3.0 FIRE FIGHTER MEASUREMENTS

Early tests conducted with the pilot compression test apparatus constructed by NIST used a knee print compression area of 2580 mm² (4 in²) and a compression force per unit area of 55.2 kPa (8 lbf/in²). This knee print compression area and compression force per unit area were borrowed from work in progress with the NFPA 1971 task group on knee pad testing. An effort to locate information documenting how the knee print compression area and the compression force per unit area values were developed was unsuccessful. Therefore, it was decided that a knee print compression study was needed to document these important parameters. As a result, FDNY conducted a study at the city fire fighter training academy.

Six fire fighters were selected from a FDNY fire fighter training class. The average body mass of these six fire fighters was 78.9 kg ± 1.4 kg (174 lbs ± 3 lbs). Knee prints of these fire fighters were made using a basic printing process. Both knees and lower legs of each fire fighter were painted with a water based tempera paint (elementary school finger paint). The fire fighter was then assisted in kneeling on a piece of clean wrapping paper. Assistance in kneeling was provided so that the knee prints would not smear. The knee prints were transferred to the paper, and the fire fighter was assisted in standing up. Again, assistance was provided to prevent the knee prints from smearing. The fire fighter's knees and legs were washed off following directions provided by the paint manufacturer. The knee print paint was allowed to dry on the paper. After all knee prints were collected, the area of each knee print was measured and recorded. An example of the knee prints is shown in Fig. 1. The knee print areas were mathematically evaluated, and the mean average knee print area was determined to be 3710 mm² (5.75 in²) with a sample standard deviation of 484 mm² (0.75 in²) and a range of 2835 mm² (4.39 in²) to 4288 mm² (6.65 in²).

The six fire fighters described in the above study also contributed to determining values for knee compression force per unit area. This study was also conducted at the FDNY fire fighter training academy. In this study, each of the fire fighters was fully clothed in their fire fighting ensemble. This ensemble consisted of underwear, station uniform, fire fighters' coat and bunker pants, helmet, hood, SCBA and facemask, gloves, and boots. The protective clothing and equipment increased each fire fighter's mass to approximately 101 kg (223 lbs). In addition, the compression force was measured while the fire fighter was operating a 44.5 mm (1¾ in) hoseline charge with a water pressure at the nozzle tip of 276 kPa (40 psi). A platform was constructed to support a kneeling fire fighter. This structure had a platform type floor scale built into it so that the scale's top surface and the support platform's top surface was maintained on the same horizontal plane. The platform scale was located where the fire fighter's right knee would rest on its top surface. The platform scale was zeroed and then calibrated, with weights of known mass, at 22.7 kg and 45.4 kg (50 lbs and 100 lbs) before a fire fighter's knee compression force was measured. Compression force was measured with the fire fighters kneeling on both knees

while they supported the operating hoseline and nozzle with their right hand. The fire fighters controlled water flow by operating the nozzle valve handle with the left hand. Each subject completed three randomly selected measurement trials. The mean compression knee force was calculated from the set of 18 measurements. The mean average compression force was calculated to be $493.8 \text{ N} \pm 13 \text{ N}$ ($111 \text{ lbf} \pm 3 \text{ lbf}$). Therefore the force per unit area, 493.8 N (50.3 kgf or 111 lbf) / 3710 mm^2 (5.75 in^2), equals a mean average of 133 kPa (19.3 lbf/in^2). These force values were used as a benchmark in this study. The apparatus described in this report may be used for studies associated with other body sizes and applied forces.

4.0 TEST APPARATUS

4.1 DEVELOPMENTAL HISTORY

The test apparatus described in this report is a third-generation design. The first-generation test apparatus was very labor intensive. Significant labor saving design changes were made in the second-generation test apparatus, and additional labor saving features were added to the third generation apparatus. The initial pilot apparatus was constructed to test the dynamic compression concept. This apparatus was a manually operated (hand cranked) system that applied a cable suspended steel weight to the specimen and compression test sensor. See the apparatus in Fig. 2. Initial tests with this apparatus confirmed the feasibility and need for construction of a more sophisticated apparatus. The second-generation test apparatus eliminated much of the manual operation through the use of a pneumatic cylinder for compressing the test sensor against the test specimen. This apparatus is shown in Fig. 3. The third-generation test apparatus described in this report was designed to improve the handling of hot water, simplify handling of test specimens, and to further reduce human labor requirements. Figures 4, 5, and 6 are photographs of the present apparatus.

It is important to note that this report has been written to document apparatus and measurement methods that may be used for evaluating the thermal performance of fire fighters' protective clothing. No attempt has been made to predict exposure times related to the development of burn injuries. Predicting thermal conditions that can cause a burn injury is a complex issue, and it is being addressed in other NIST measurement and modeling studies. However, results produced by this test methodology do provide detailed comparative data on the thermal performance of fire fighters' protective clothing while exposed to various environmental conditions. These data are being used to assist in evaluating computer models that are under development for predicting the thermal performance of fire fighters' protective clothing. In addition, these data may also be used by computer based methods for predicting burn injury potential. Burn injury prediction methods may be found in ASTM standards C 1055 and C 1057 [9][10]. Also see studies conducted by Alice Stoll, et al. [11][12], Moritz and Henriques [13], and F.S. Knox, et al. [14]. Stoll and Chianta [11] provide basic background information on human skin burn injuries. They state in their study that the severity of a skin burn injury depends upon the elevation of human tissue temperature to a level higher than $44 \text{ }^\circ\text{C}$ ($111 \text{ }^\circ\text{F}$) and that severity of a burn injury is an inverse relationship of time to tissue temperature. They also state that the rate at which a burn injury proceeds increases logarithmically with a linear increase in skin temperature so that at a skin temperature of $50 \text{ }^\circ\text{C}$ ($122 \text{ }^\circ\text{F}$) damage proceeds at 100 times the rate ensuing at $45 \text{ }^\circ\text{C}$ ($113 \text{ }^\circ\text{F}$). Research by Stoll and Greene [12] shows that when human

skin reaches a temperature of 55 °C to 60 °C (131 °F to 140 °F) a second degree burn will occur. This type of burn injury causes blisters and complete destruction of the epidermis. A second degree burn injury is considered to be serious [9].

It is important that the reader understand that temperatures presented in this report are not human tissue temperatures. The temperatures are from thermocouples attached to fire fighters' protective clothing fabrics, and simple attempts to estimate the potential for burn injury from these data may be misleading.

4.2 APPARATUS DESCRIPTION

This test apparatus was designed for evaluating the thermal performance of fire fighters' protective clothing over a wide range of thermal exposures, time, compression force, and rate of compression. Samples of fire fighters' protective clothing systems may be tested while exposed to either wet or dry thermal exposures. Heat energy applied to the test apparatus may be varied for the evaluation of protective clothing systems over a wide temperature range. This temperature range may vary with the wet test from normal ambient room temperature up to approximately 100 °C (212 °F). Under dry test conditions, the hot plate temperature may be varied from normal ambient room temperature up to 482 °C (900 °F). Test duration can be varied as needed based on the scenario under study. Currently, data may be collected for a period of at least 30 minutes. Also, the apparatus was designed to allow for tests to be conducted with different compression cycle rates. An electronic timer controls the rate at which the pneumatic cylinder is activated for the compression and non-compression cycle. With this, compression cycles may be adjusted from periods representing several minutes to periods as short as two seconds.

Six basic component systems make up this third-generation compression test apparatus. These component systems are as follows: (1) compression system, (2) hot water system, (3) hot plate, (4) specimen holder, (5) test sensors, and (6) data acquisition system. The photographs in Figs. 4, 5, 6, and 7 show the apparatus assembly. Engineering drawings for the construction of this apparatus are contained in the Appendix.

4.2.1 COMPRESSION SYSTEM

The compression system is made up of a stainless steel frame that supports a pneumatic cylinder and the pneumatic cylinder latching assembly. The pneumatic cylinder is operated by an electric control system. See Figs. 4 through 7. Schematics of the pneumatic control system and the electric control systems are found in the Appendix.

The pneumatic double acting stainless steel cylinder has a 38 mm (1.5 in) diameter bore with a 76 mm (3 in) stroke. The full cylinder stroke is used for compression and release of force. A 689.5 kPa (100 psi) compressed air supply feeds operating air to the pneumatic cylinder through two manually controlled, diaphragm type, pressure reducing regulators. The first regulator is positioned to isolate the apparatus for the primary air supply system, and the second regulator is used to adjust air pressure to the pneumatic cylinder. Air pressure to the pneumatic cylinder is changed to adjust compression force to the test specimen. In addition to the pressure regulators,

two pneumatic speed control valves are operated in the air cylinder circuit to control the piston's rate of movement. These speed control valves have been added to eliminate high-speed impact conditions that would not be typical when the human knee is pressed on a hard surface. Using the data generated in the FDNY studies listed above, air pressure to the cylinder is adjusted to provide a compression force of 493.8 N (50.3 kgf or 111 lbf) to the test sensor. This setting is determined by dividing the intended compression force 493.8 N (50.3 kgf or 111 lbf) by the area of the pneumatic cylinder's piston 1140 mm² (1.767 in²). Therefore, air pressure to the pneumatic cylinder is set at 433 kPa (62.8 psi). This gives an overall compression force per unit area of 133 kPa (19.3 lbf/in²) to the disk shaped 3710 mm² (5.75 in²) sensor.

The complete compression assembly and control unit can be quickly removed from the hot water test apparatus and reassembled for conducting dry hot surface compression tests. This is accomplished by making the test apparatus safe by first removing all electrical power from the hot water bath system and pneumatic control system. Also, air to the pneumatic operating system must be turned off, and all air must be purged from the system. All hot water must be allowed to cool and must be drained from the water container. All hot surfaces must be allowed to cool. Bolts that hold the stainless steel frame to the hot water container are removed, and the compression frame assembly is lifted from the hot water container assembly. The compression assembly is moved to a location with appropriate ventilation. A laboratory chemical hood has been used to remove gasses, odors, and smoke from tests described in this report. A hotplate is inserted into the test frame, and it is centered under the pneumatic cylinder assembly. This complete process may be accomplished over a one hour time period.

4.2.2 HOT WATER SYSTEM

The container that holds water for wet testing is shown in Fig. 7, and an engineering drawing for the container is shown in the Appendix starting at page A2. The thermally insulated water container is constructed from 1.59 mm (16 ga) stainless steel. The 38 mm (1.5 in) container walls are filled with glass fiber insulation to assist in preventing the development of hot surfaces that may cause burn injuries. This container holds a maximum of approximately 62.2 L (16.4 gal) of water. Water level in the test container is controlled by manually adjusting inlet and drain valves. Water level is typically adjusted to be 12.7 mm (0.5 in) above the compression surface or floor material attached to the substrate support. See Figs. 4, 6, and 7. A manually operated set point gauge attached to the container wall is adjusted to provide a comparative indication of water level to the compression surface material. Test water flows through a 9.5 L (2.5 gal), 1350 W hot water heater that preheats water for the test apparatus. Make-up water is provided through this hot water heater for testing when test specimen materials absorb excess water or water evaporates from the system.

The compression surface material or test substrate, mentioned earlier, may be changed to represent a wide range of flooring material types. The current test configuration uses a nominal 25.4 mm (1 in) thick pine wood block for the compression surface substrate. Three conventional hot water heater elements extend from the container's side walls into the water. The three 1650 W heating elements operate from common single phase 120 VAC, 20 A, electrical receptacles. The heating elements are separated from one another in an attempt to more evenly heat the water. In addition, an electric propeller stirrer is inserted into the tank to assist in mixing

the water for creating relatively uniform temperatures throughout the container and water column. Two of the container's heating elements are used to increase water temperature to the operating range needed for a particular test. Either one of these elements or both may be operated to bring water temperature into the appropriate test range. Both base temperature heating elements are typically needed for maintaining test water temperatures from 75 °C to 100 °C (167 °F to 212 °F). The third heating element is electronically controlled to maintain the water at a given set point temperature. A grounded, stainless steel jacketed, 3 mm (0.125 in) diameter, type K thermocouple extends from the container's side wall into the water approximately 254 mm (10 in). This thermocouple is connected to the electronic temperature controller that operates one of the hot water heating elements. The heater elements and the control system are shown schematically in the Appendix on page A43.

The operating hot water test system produces visible vapors as the evaporating water condenses. The laboratory test area must be appropriately protected to insure that these vapors don't collect on electrical service outlets, electrical connections, and electric or electronic equipment. Moisture may also collect on other cool surfaces close to the test apparatus. Appropriate ventilation is needed to insure that the laboratory maintains a safe and functional environment.

4.2.3 HOT PLATE

The hot plate used with this test apparatus for the dry hot surface tests is an industrial quality apparatus. Figure 8 shows the hot plate in use. This hot plate has a temperature operating range of 100 °C to 482 °C (212 °F to 900 °F). The top surface of this hot plate measures 228 mm by 228 mm (9 in by 9 in) square. The 1000 W hot plate operates from a 120 VAC, 9.0 A electric circuit. Modifications were needed to the hot plate's supporting structure for carrying the loads required for this test procedure. A 6.4 mm (0.25 in) thick copper plate measuring 152.4 mm by 152.4 mm (6 in by 6 in) square was placed on the top center of the hot plate to distribute heat energy evenly to the test specimen during testing. This copper plate was cleaned occasionally to remove oxidation or decomposition products from its surface.

When dry compression tests were run at high temperatures, the protective clothing test specimens often produced decomposition products. Odors from thermally decomposing materials are typically produced, and smoke is produced with some high temperature exposures. Therefore, the dry compressed test apparatus was operated inside a laboratory chemical hood to reduce the possibility of exposing test personnel to hazardous decomposition products.

4.2.4 SPECIMEN HOLDER

The test specimen holder was designed to hold the test specimen in a reproducible test position and to provide for the specimen to be compressed and then lifted away from the thermal exposure. The rectangular shaped specimen holder was also designed to allow complete protective clothing knee pad systems to be attached so that it would not allow water to leak into the specimen from around the unfinished edges. With this design, if water entered the protective clothing system it would enter only from the finished front side of the garment.

Specimens are attached to the specimen holder using the following procedure:

1. The specimen is laid out flat with the shell fabric face down on a clean surface.
2. The specimen holder is centrally located on the back of the test specimen.
3. Each edge is folded up into contact with the test specimen holder and clipped into place with a metal binder clip. Each end corner is then folded together and clipped. This produces a rectangular cup-shaped test specimen.
4. The test specimen holder is then attached to the pneumatic cylinder shaft using the specimen holder lift clip (Appendix page A13) and force distribution block (Appendix page A11).

4.2.5 TEST SENSORS

Thermal sensors used with this test apparatus for this study have consisted of 0.254 mm (0.010 in) type K thermocouples. These thermocouples are attached to the test specimen at the locations shown in Fig. 13. These locations are on (1) the center of the outside surface of the knee pad, (2) the center inside surface of the garment system between the knee pad and the garment shell layer, and (3) three thermocouples are attached to the 3710 mm² (5.75 in²) compression sensor disk. Details on the compression disk are shown on Appendix pages A9 and A10.

The compression sensor disk is constructed from a 12.7 mm (0.5 in) thick phenolic material. The average thermal properties for phenolic materials of this type are: thermal conductivity, k , 418.7 kW/m K (1.0×10^3 cal/s-cm-°C); specific heat, c , 1381.7 J/kg K (0.33 cal/g-°C); density, ρ , 1250 kg/m³ (1.25 g/cm³); thermal diffusivity, α , 0.24 m²/s (2.4×10^3 cm²/s); with a thermal inertia, λ , (product of $k\rho c$) of 7.23×10^5 kW² s/m⁴ K² (0.41×10^3 cal²/s-cm⁴-°C²) [9].

4.2.6 DATA ACQUISITION SYSTEM

A computer controlled data logger is used for recording test data. The data logger used in this study has eight input channels. The number of data input channels required is determined by the number of thermal sensors needed for a given test. Typically, five sensors are used to measure test specimen performance, and one thermocouple is used to track water bath or hot-plate temperature. Each data channel is scanned and recorded once every second. The data logger contains a cold-junction temperature compensation device with a reference temperature of 0 °C (32 °F) for thermocouple temperature measurements.

4.2.7 LABORATORY BALANCE

An electronic balance was used to determine specimen mass before and after testing. This balance had a maximum load capacity of 12.5 kg and a resolution of 0.1g.

5.0 TEST SPECIMENS

5.1 DESCRIPTION

Test specimens used during the development of this apparatus were constructed from materials that are currently being used to fabricate fire fighters' protective clothing. Figure 9 shows examples of different knee pads that were used. The knee pad test specimens were designed to meet the NFPA 1971 standard [4]. The general order of construction for the knee pads was as follows: knee pad outer fabric or scuff resistant surface, pad thermal insulating material, pad moisture barrier, pad back surface fabric and/or garment outer shell fabric, garment moisture barrier, and finally the garment thermal liner. The knee pad test specimens varied in types of scuff resistant surface, thermal insulating material, moisture barriers, and outside dimensions, but they were constructed to dimensions that represented those actually used on fire fighters' protective clothing. Typical outside dimensions for these knee pad systems were 305 mm (12 in) wide and 380 mm (15 in) long.

5.2 CONDITIONING

Test specimen conditioning may vary with the type of research study being conducted. However, the conditioning procedure specified in NFPA 1971, 1997 edition [4], was followed while testing the protective clothing knee pad assemblies discussed in this report: Each knee pad was machine washed and dried five times using the procedures specified in section 6-1.2.1. In addition, the specimens were brought to equilibrium before testing using the procedures specified in section 6-1.3.1. Equilibrium conditioning parameters used prior to testing were $21\text{ }^{\circ}\text{C} \pm 3\text{ }^{\circ}\text{C}$ ($70\text{ }^{\circ}\text{F} \pm 5\text{ }^{\circ}\text{F}$) with a relative humidity of $65\% \pm 5\%$. The test specimens were maintained in these equilibrium conditions until the time for testing. At this point, 5 g (0.01 lbs) of distilled water was evenly sprayed across the quilted thermal liner surface of the knee pad specimen. This level of wetting represents an initial wetting process of a working fire fighter. Research by Malley shows that working fire fighters that are wearing protective clothing can produce approximately 23 kg (5 lb) of sweat per hour [10]. This fabric surface would be next to a fire fighter's skin, and the water would represent wetting from human perspiration.

6.0 EXPERIMENTAL PROCEDURE

Since the test apparatus was designed to evaluate the thermal performance of protective clothing when exposed to either wet or dry conditions, two different but similar procedures were used. All test specimens were weighed on a laboratory balance prior to testing to ensure that the specimens had reached mass equilibrium. The balance is described above in section 4.2.6.

In tests where water was added to the specimen's thermal liner to represent perspiration, the specimen was laid on the balance while 5 g (0.01 lb) of distilled water was sprayed evenly across the thermal liner's fabric. The test specimen was immediately attached to the rectangular frame, shown in Figs. 6 and 9, with metal binder clips. The specimen's outside edges were folded up around the specimen frame, and binder clips were used to attach the specimen to the frame. In wet tests, this specimen configuration prevents hot water from the tank from flowing over the specimen edges. Tests were stopped if water flowed over the back of a specimen during the test.

This was done to insure that the test was measuring heat flow through the protective components of the garment assembly and to eliminate errors that may occur from hot water flowing over the specimen's back surface.

The complete specimen and frame assembly was weighed before testing to determine its total mass. The initial total mass was used with the final total mass to determine specimen mass gain or loss during the test.

6.1 WET TEST PROCEDURE

All wet test data presented in this report were generated following the procedure listed below. Examples of test data are presented in section 8.0.

- The hot water heater was started, and the water container was filled so that the water level would be 12 mm (0.5 in) above the wood flooring material. The water level set-point gauge marker was adjusted so that the pointed tip just touched the water's surface, and it was locked into place. In addition, the water container heating elements were turned on, and the electric stirrer was turned on to circulate water around the container. The water was heated to a temperature of $90\text{ }^{\circ}\text{C} \pm 2\text{ }^{\circ}\text{C}$ ($194\text{ }^{\circ}\text{F} \pm 4\text{ }^{\circ}\text{F}$).
- The pneumatic compression system was adjusted to produce a compression force of 133 kPa (19.3 lbs/in^2) using the 3710 mm^2 (5.75 in^2) sensor disk. The compression cycle was adjusted for six compressions per minute. Each cycle consisted of a seven second compression period followed by a load-free period of about three seconds.
- After the test specimen and frame was assembled and weighed, the data logger was started. The test specimen assembly was attached to the pneumatic compression system and mounted on the test apparatus. The test was started automatically as the test specimen/pneumatic system assembly was latched into place on the test apparatus.
- Water level usually required some minor adjustments during the test to account for evaporation and mass absorption caused by the test specimen. This was accomplished by manually opening the hot water heater valve and filling the water container back to the fill level set-point gauge mark.
- Data were collected continuously over a test period of 17 minutes.
- The test was ended by shutting off the compression system at the end of the 17 minute period. This causes the pneumatic cylinder to lift from the water container if it is in a compressed state.
- Data logging was stopped. If the measurement of stored energy or rate of heat loss from a garment system is important, the data logger may be left running over the specimen cool down period.
- The test specimen and frame assembly was immediately removed from the test apparatus, and the pneumatic cylinder was removed from the specimen assembly. Water droplets clinging to

the test assembly surface were wiped off with a paper towel, and the specimen assembly was weighed again to measure mass gain.

6.2 DRY TEST PROCEDURE

The dry test procedure was conducted with the hot plate and test apparatus located in the center of a chemical hood. This was done to remove odors and other decomposition gasses from the room as the test specimens were heated on the hot plate. Examples of test data are shown in section 8.0. All dry test data discussed in this report were developed with a hot plate temperature set at 260 °C (500 °F). The hot plate used in this study is described in section 4.2.4.

- A 120 VAC Variac was used to set the hot plate temperature and to help control temperature during the test.
- For the dry test, the compression apparatus was positioned over the geometric center of the hot plate. The pneumatic piston stroke was adjusted to provide maximum compression against the hot plate, and the compression force was adjusted to 133 kPa (19.3 lbs/in²) while using the 3710 mm² (5.75 in²) sensor disk located between the pneumatic piston and the hot plate surface. The compression cycle was adjusted for six compressions per minute. Each cycle consisted of a seven second compression period followed by a load-free period of about three seconds.
- After the test specimen and frame was assembled and weighed, the data logger was started. The test specimen assembly was attached to the pneumatic compression system and mounted on the test apparatus. The test was started automatically as the test specimen/pneumatic system assembly was latched into place on the test apparatus.
- Data were collected continuously over a test period of 17 minutes.
- The test was ended by shutting off the compression system at the end of the 17 minute period. This causes the pneumatic cylinder to lift from the hot plate if it is in a compressed state.
- Data logging was stopped. If the measurement of stored energy or rate of heat loss from a garment system is important, the data logger may be left running over the specimen cool down period.
- The test specimen and frame assembly was immediately removed from the test apparatus, and the pneumatic cylinder was removed from the specimen assembly. The specimen assembly was weighed again to measure mass loss. The test specimens usually produce an odor as a result of being heated, and they were returned to the chemical hood to cool and to remove the odor.

7.0 PRECISION

There are five variables that have the greatest impact on precision with this test. They are: 1) variation in temperature, 2) sensor response characteristics, 3) data logger resolution for voltage measurement, 4) data logger sample rate precision, and 5) compression force variations. Variations in sensor attachment, thermocouples as presented in this report, have little impact on

precision since the area where the sensor is located becomes uniformly compressed. Item 1, temperature in the water container is maintained by a microprocessor-based temperature controller that is capable of regulating water container temperature to a level of $\pm 3\text{ }^{\circ}\text{C}$ ($\pm 5.4\text{ }^{\circ}\text{F}$) [17]. Temperature controller uncertainty is $\pm 0.25\%$ of the operating span. Operating temperature for the dry unloaded hot plate is controlled by a thermostat that maintains the temperature at a level of $\pm 2.5\text{ }^{\circ}\text{C}$ ($\pm 4.5\text{ }^{\circ}\text{F}$) of the set-point temperature [18]. Item 2, type K thermocouple response is primarily related to temperature lag during a rising and falling temperature condition. This temperature lag is estimated to be approximately 0.25 s [19]. Item 3, the data logger voltage resolution for the $\pm 50\text{ mV}$ scale is $3.33\text{ }\mu\text{V}$ [19], and the data logger input sample rate, item 4, is 18.8 ms per channel with a clock error of one minute per month [20]. Item 5 depends on the level of control provided by the pneumatic regulator. This regulator has a repeatability of $\pm 551\text{ Pa}$ ($\pm 0.08\text{ lbf/in}^2$) for a change in flow and $\pm 1.1\text{ kPa}$ ($\pm 0.16\text{ lbf/in}^2$) when the air supply is turned off and on [21]. Overall test result variation based on temperature is estimated to be less than $\pm 5\text{ }^{\circ}\text{C}$ ($\pm 9\text{ }^{\circ}\text{F}$) for the wet compression and dry compression tests.

8.0 EXAMPLES OF TEST DATA

This test apparatus provides for measuring the thermal performance of protective clothing systems and individual components of the clothing system during the same test. This is shown by the data examples listed below. The test procedures listed above were used to generate the wet and dry compression test data presented in this section.

The following example provides insight into how garment compression affects the performance of thermal protective clothing. See Fig. 10. These test data were developed using identical dry protective garment knee pad specimens consisting of insulating batting sandwiched between two layers of shell material. These pads were sewed to the shell material of protective garment specimens formed from a shell material, moisture barrier, and quilted thermal liner. In the compressed test, the specimen was placed on the hotplate with the test sensor placed on the thermal liner's back surface, compressed and held under compression throughout the test with a compression force of 133 kPa (19.3 lbs/in²). In the uncompressed test, the specimen was placed on the hotplate with only the test sensor laying on the thermal liner's back surface. The temperature plots were created using data obtained from the test sensor described in section 4.2.5. The time, 0 s, on the plots represent the point in time when the specimens were placed on the hot plate. It also represents the time when compression was started on the compressed specimen. Both the compressed and uncompressed specimens show similar heating characteristics over the first 30 s. This rate of heat transfer is controlled by the specimen material's thermal physical properties. However, at about 30 s a significant heating rate change occurs. The compressed test specimen exhibits a rapid increase in temperature as compared to the uncompressed test. In addition, the rate of temperature rise continues to be greater throughout the test with the compressed specimen as compared to the uncompressed specimen. This change in heating rate primarily results from a change in garment density caused by the loss of air space during compression. Results shown in this figure demonstrate how thermal performance can be significantly altered by garment compression.

8.1 WET TEST DATA

Figures 11 and 12 show examples of compression apparatus wet test data. Figure 11 shows typical temperature data plots from a single test. The knee pad system in this test consisted of a fabric covered roll of insulating fiber on the outer surface, a permeable moisture barrier layer, a layer of fabric on the pad's inside surface, the protective clothing garment shell fabric, the garment's permeable moisture barrier, and the garment's thermal liner. Figure 13 shows the knee pad's construction details. The data plots show the knee pad's outer surface temperature, the temperature between the knee pad's back surface and the protective clothing outer shell, and the temperature on the inside of the garment's thermal liner. This last data plot represents the temperature that would be next to the fire fighter's uniform pants or skin, and it is the median average temperature of the three thermocouples attached to the compression disk.

Figure 12 shows data plots of median average temperatures from the compression disk's thermocouples for six different knee pad constructions. Most of these knee pad designs are currently being used by the fire service.

8.2 DRY TEST DATA

Figure 14 shows six data plots of median average temperature from the compression disk's thermocouples. These test data represent identical specimens as those protective clothing knee pad designs plotted in section 8.1. Each data plot identification number, 1 through 6, for the dry knee pad tests shown in Fig. 14 represents an identical knee pad design and construction to those plots, 1 through 6, shown in Fig. 12 of the wet knee pad tests.

8.3 DISCUSSION

Figure 11 shows a typical set of data plots from a wet compression test. Each of the three plots shows a periodic pattern. The increase and decrease in temperature results from the test's compression cycle. The increase in temperature is caused by the compression phase of the cycle as the garment system is compressed into the heated water. The decrease in temperature results from the lifting phase of the cycle. Also, note that the greatest amount of temperature change occurs at the thermocouple located on the outer surface. Temperature variation becomes less as measurements are made through the garment's thickness. Also, note in Fig. 11 that there is a significant difference in temperature between the outer surface and the back surface that would be next to the fire fighter's body. This temperature difference is controlled by the garment's design and thermal properties of the garment's components. In addition, this temperature difference represents the thermal protective qualities of the garment system. An important observation in this set of plots is that the thermal protective performance of the garment system becomes less with time. A level of thermal protection is afforded during the first two minutes of the exposure, but this level of protection rapidly becomes less with continued exposure and time.

Figure 12 provides data plots for six different knee pad/protective clothing designs. Each of the plots represents the measurement of temperature located on the inside of the garment assembly located next to a fire fighter's work uniform or skin. This figure was prepared to show that there are major differences in thermal performance for protective clothing knee pad designs, during

wet thermal exposures. Figure 14 shows dry compression test results for the same protective clothing knee pad systems. As can be seen, some of the knee pad systems that performed well during the wet test (specimens 4, 5 and 6) didn't do as well when tested using the dry compression exposure. The designs represented by specimens 1, 2, and 3 generally performed in a fashion consistent with the wet compression test. Results from tests of design number 3 suggest that this knee pad system has properties that benefit performance in both wet and dry thermal environments. In addition, all the data show that designs may be optimized to increase thermal performance for both wet and dry fire fighting operations. And, the data shows that the wet and dry compression test apparatus may be useful in detecting changes in thermal performance associated with differences in garment design.

9.0 SUMMARY

Injury data from the New York City Fire Department indicated that a study was needed to better understand the dynamics associated with the causes of burn injuries to fire fighters' knees. This burn injury study by FDNY provided fresh insight into the causes of burn injuries to the knees of fire fighters. In addition, the FDNY training academy study provided new information on the compressed surface area of the human knees of kneeling fire fighters. This study by FDNY also assists in defining the amount of compression force applied to the knees of fully equipped working fire fighters. This information generated by FDNY has assisted in the development of a new test apparatus that can measure differences in the thermal performance of fire fighters' protective clothing during garment compression. The test apparatus may be used to evaluate protective clothing thermal performance under either wet or dry test conditions that simulate specific fire ground conditions. The test apparatus is designed and constructed to provide flexibility in testing while allowing the use of a wide range of thermal environmental conditions and compression cycle and force scenarios. Test data generated by this apparatus should be useful in developing protective clothing designs, and helping to standardize the thermal performance of fire fighters' protective clothing.

10.0 ACKNOWLEDGEMENTS

The United States Fire Administration (USFA) partnered with NIST and co-sponsored this study. Appreciation is extended to Mr. Robert T. McCarthy, Chief, Fire Technical Programs Branch, USFA for his support, ideas and comments related to this project. Appreciation is also extended to Mr. Thomas Von Essen, Fire Commissioner, New York City Fire Department, for his assistance in making this study possible. Chief Stephan J. King (FDNY) and Battalion Chief Hughie Hagan (FDNY) are recognized for their efforts that supported this research effort. Appreciation is extended to Globe Firefighter Suits; Lion Apparel; and Morning Pride Manufacturing, Inc. for manufacturing and supplying protective garment specimens to be used in the development of this test apparatus.

11.0 REFERENCES

- [1] Karter, Michael J., Jr., "U.S. Firefighter Injuries 1996," NFA Journal, National Fire Protection Association, Quincy, MA, November/December 1997.
- [2] Karter, Michael J., Jr. "Patterns of Fire Fighter Injuries, 1989-1991," National Fire Protection Association, Quincy, MA, December 1993.
- [3] Prezant, D. J., M.D. and Cacciola, M., "12 Month Survey of Serious Firefighter Knee/Lower Leg Burn Injuries (12/1/97 – 11/30/98), New York City Fire Department, New York, December 1998.
- [4] NFPA 1971, Standard on Protective Ensemble for Structural Fire Fighting, National Fire Protection Association, Quincy, MA.
- [5] ASTM F1060, Standard Test Method for Thermal Protective Performance of Materials for Protective Clothing for Hot Surface Contact, American Society for Testing and Materials, West Conshohocken, PA.
- [6] Lawson, J. Randall, "Fire Fighter's Protective Clothing and Thermal Environments of Structural Fire Fighting," NISTIR 5804, National Institute of Standards and Technology, Gaithersburg, MD, August 1996.
- [7] Bennett, C.O. and Myers, J.E., "Momentum, Heat, and Mass Transfer," Second Edition, McGraw-Hill Book Company, New York, 1974.
- [8] Lawson, J. Randall, "Thermal Performance and Limitations of Bunker Gear," Fire Engineering, PennWell Publishing Co., Tulsa OK, August 1998.
- [9] American Society for Testing and Materials, C1057 Standard Practice for Determination of Skin Contact Temperature from Heated Surfaces Using A Mathematical Model and Thermesthesiometer, Annual Book of ASTM Standards, Vol. 04.06, West Conshohocken, PA, 1997.
- [10] American Society for Testing and Materials, C1055 Standard Guide for Heated System Surface Conditions That Produce Contact Burn Injuries, Annual Book of ASTM Standards, Vol. 04.06, West Conshohocken, PA, 1997.
- [11] Stoll, Alice M. and Chianta, Maria A., Method and Rating System for Evaluation of Thermal Protection, Aerospace Medicine, Vol. 40 (11), pp. 1232-1237, November 1969.
- [12] Stoll, Alice M. and Greene, Leon C., Relationship between pain and tissue damage due to thermal radiation, Journal of Applied Physiology, Vol. 14, pp. 373-382, May 1959.

- [13] Moritz, A.R., and Henriques, Jr., F.C., "Studies of Thermal Injury II. The Relative Importance of Time and Surface Temperature in the Causation of Cutaneous Burns," *America Journal of Pathology*, Vol. 23, No. 5, 1947.
- [14] Knox, F.S. III; Bonetti, Dena; and Perry, Chris, "User's Manual for BRNSIM/BURNSIM: A Burn Hazard Assessment Model," USAARL Report No. 93-13, Air Force Systems Command Wright-Patterson Air Force Base, Ohio, United States Army Aeromedical Research Laboratory, Fort Rucker, Alabama, February 1993.
- [15] Wu, Yung-Chi, "Materials Properties Criteria for Thermal Safety," *Journal of Materials*, Vol. 7, No.4, American Society for Testing and Materials, West Conshohocken, PA. 1972.
- [16] Malley, Kevin Lt., "The Influence of Protective Clothing on Firefighter – Health & Work Performance," *Health and Safety Newsletter*, Fire Department New York (FDNY), December 1996.
- [17] Omega Engineering, Inc., *Operator's Manual M1303/0493*, Stamford, CT, 1993.
- [18] Barnstead/Thermolyne, *Hotplate Controller*, data sheet, Dubuque, IA
- [19] Omega Engineering, Inc., *The Temperature Handbook*, Volume 29, Stamford, CT, 1995.
- [20] Campbell Scientific, Inc., *21X Datalogger Operator's Manual*, Logan, UT, 1989.
- [21] C.A. Norgren Company, *Precision Regulator, Model 11-018-110*, data sheet, Littleton, CO., 1971.



Left Knee



Right Knee

Figure 1 Examples of fire fighter's knee prints, shown actual size.

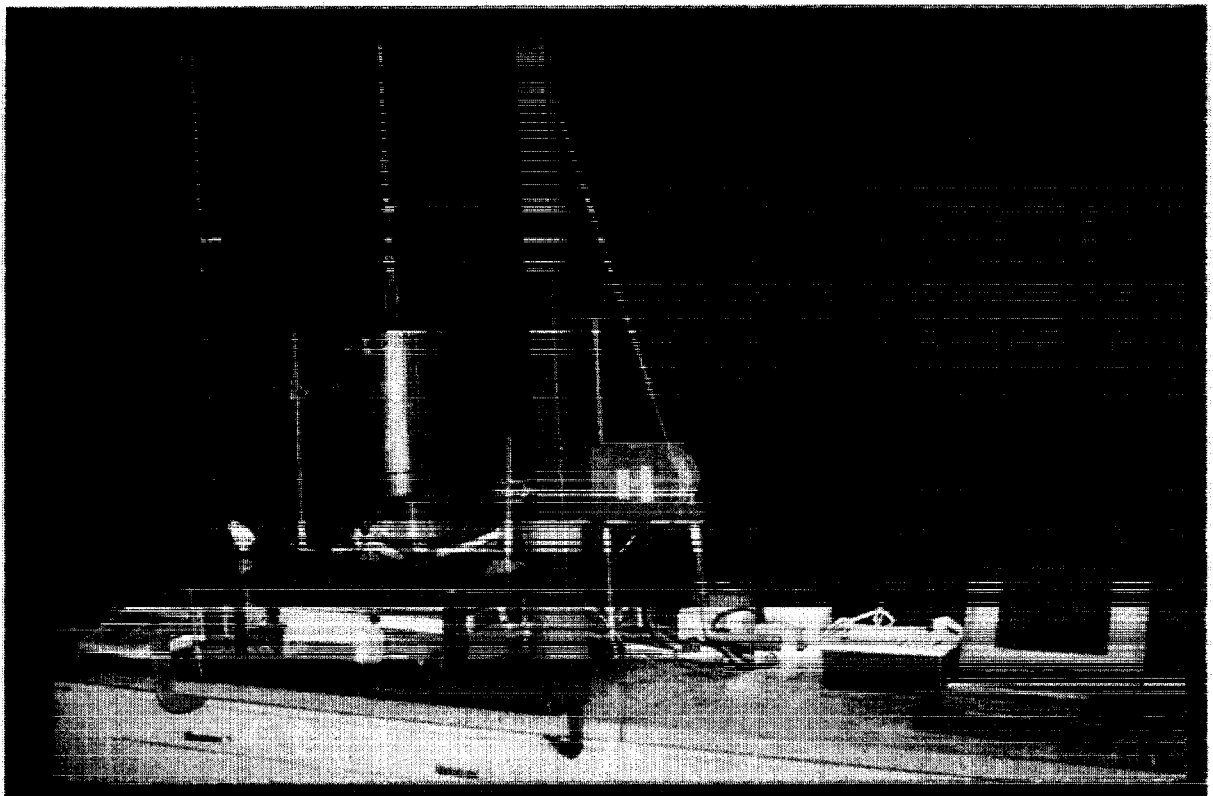

Figure 2 Concept apparatus for wet knee pad compression testing.

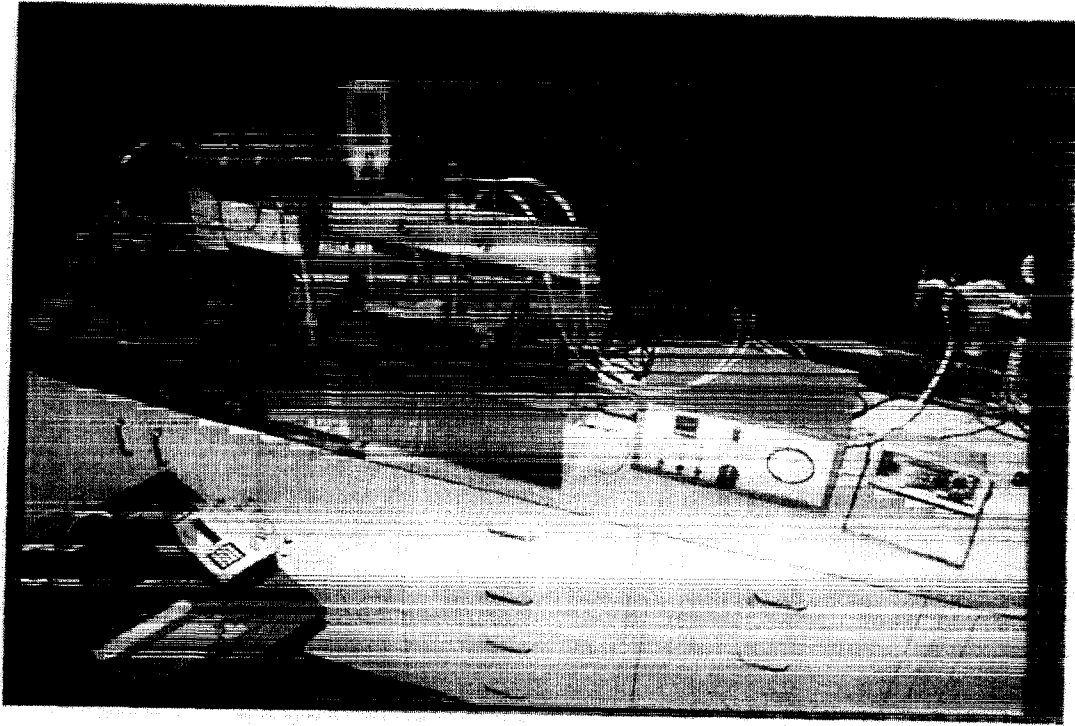

Figure 3 Second generation compression test apparatus.

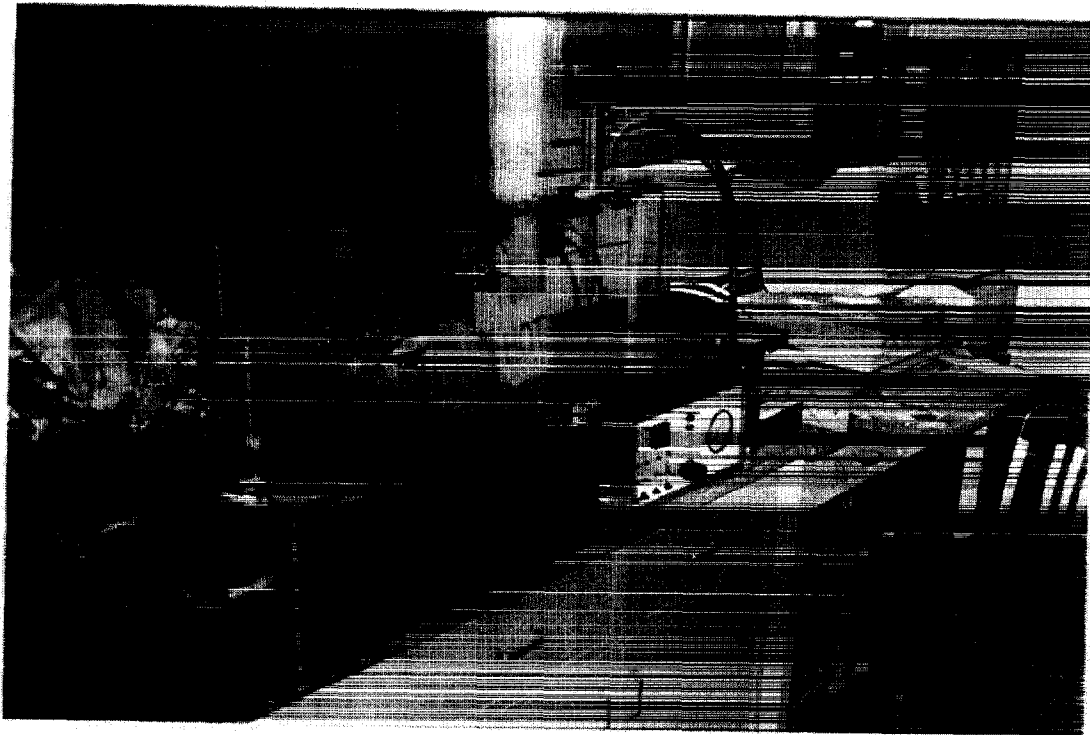

Figure 4 Test apparatus as described in this report.



Figure 5 Knee pad specimen prepared for testing.

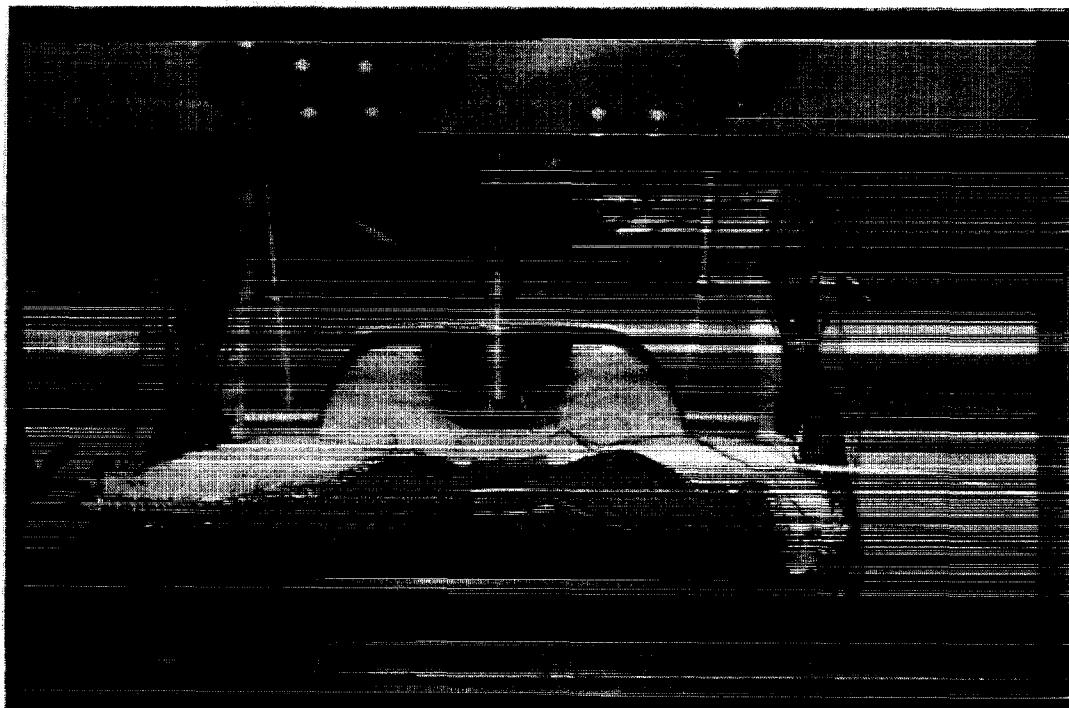

Figure 6 Compression apparatus specimen assembly prepared for wet testing.

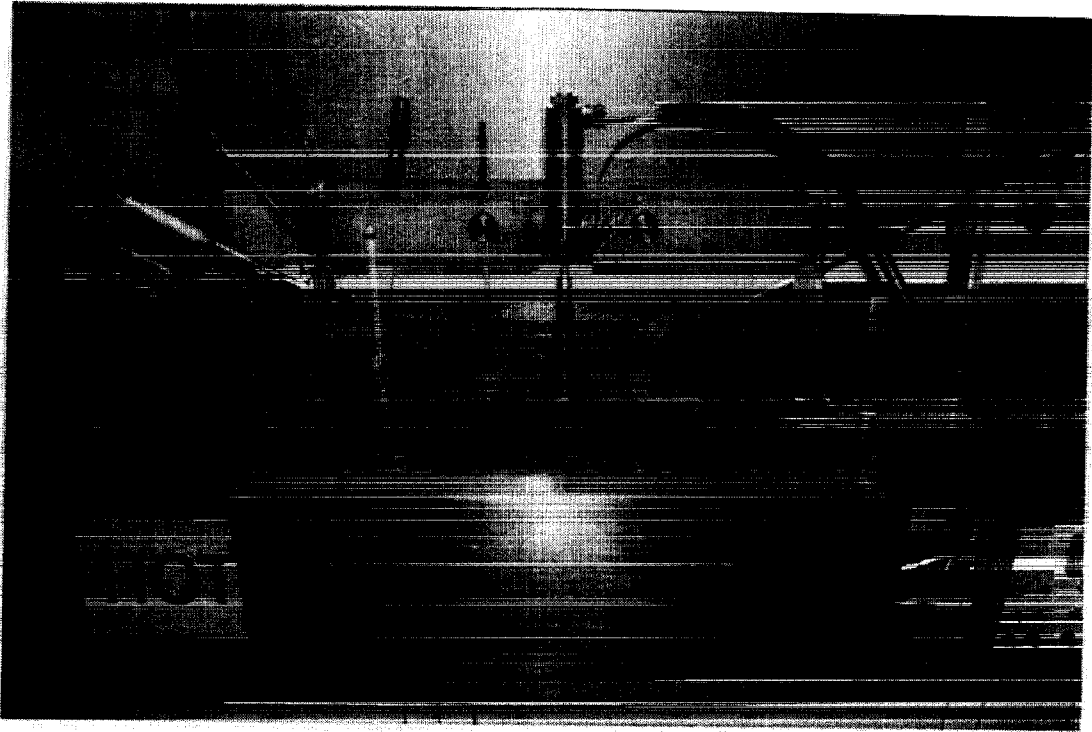

Figure 7 Apparatus during wet compression testing.

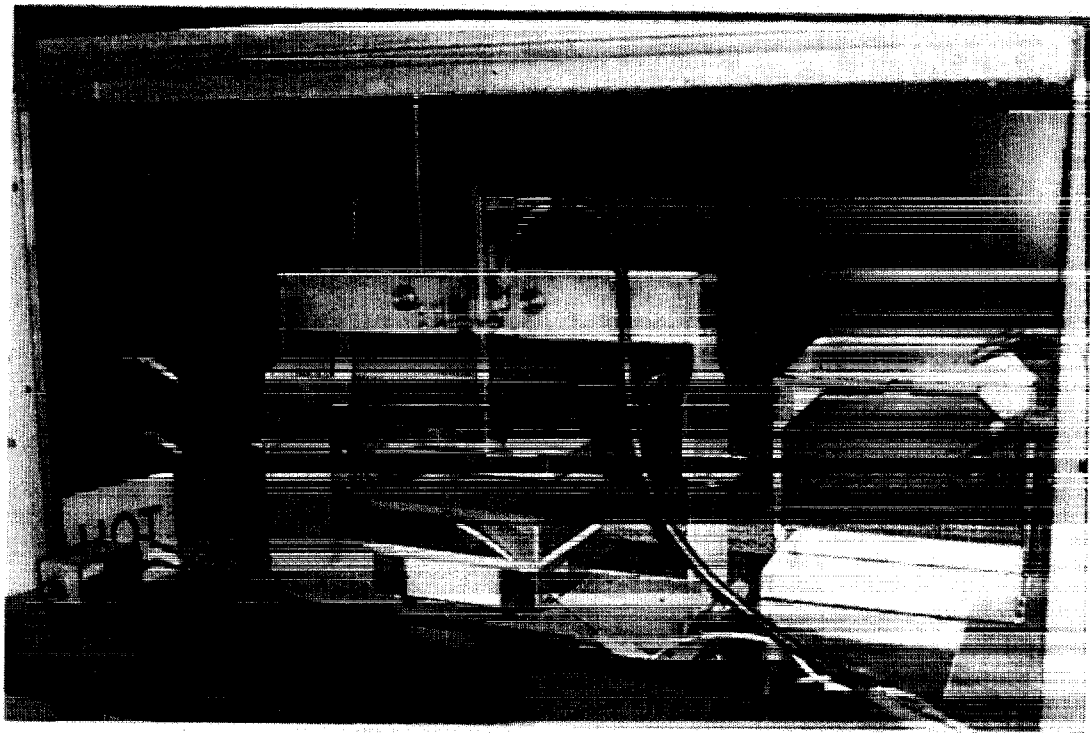

Figure 8 Compression apparatus prepared for dry hot surface testing.

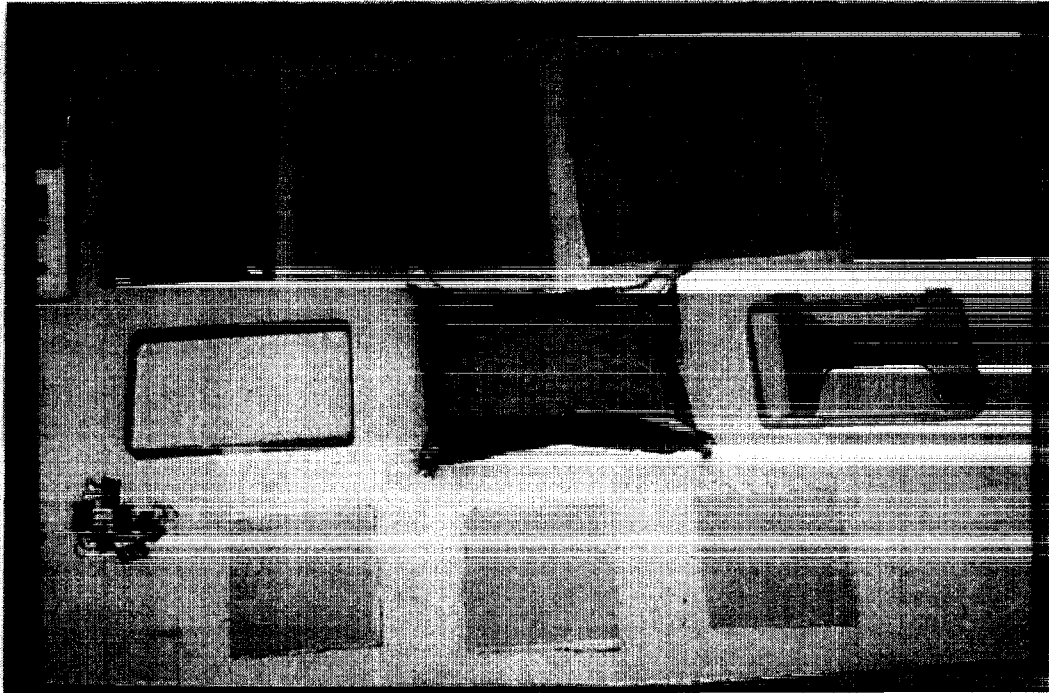

Figure 9 Examples of test specimens used during apparatus development

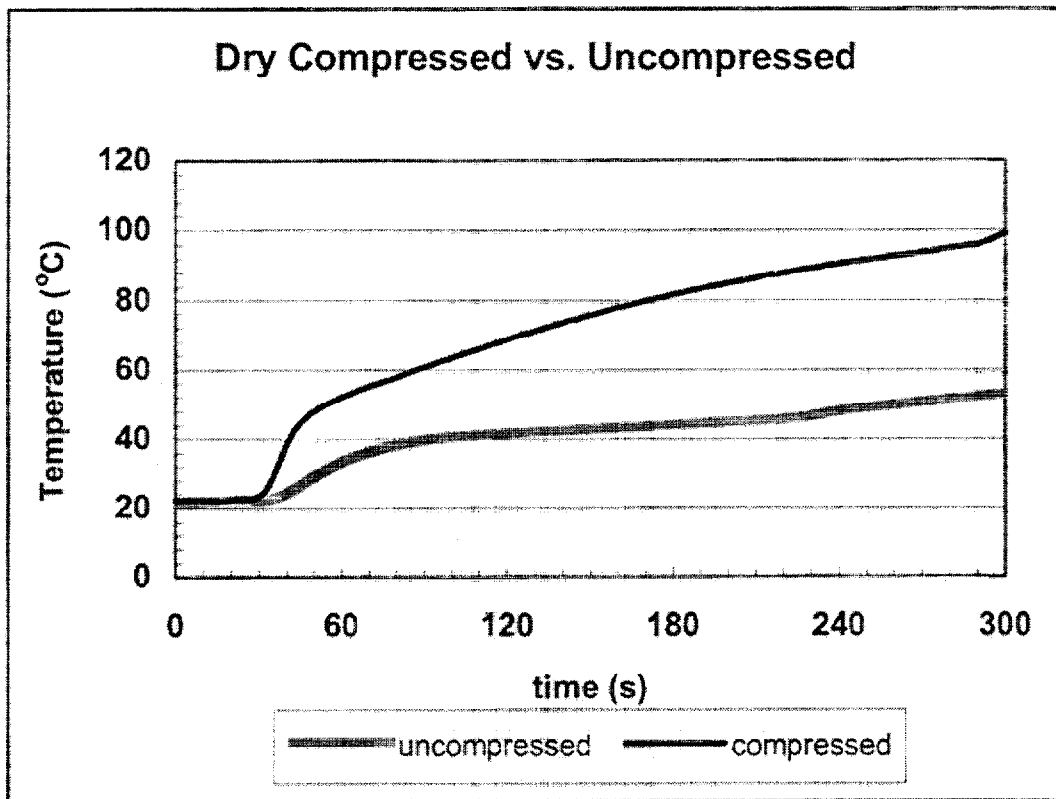

Figure 10 Comparison of protective clothing compressed and uncompressed.

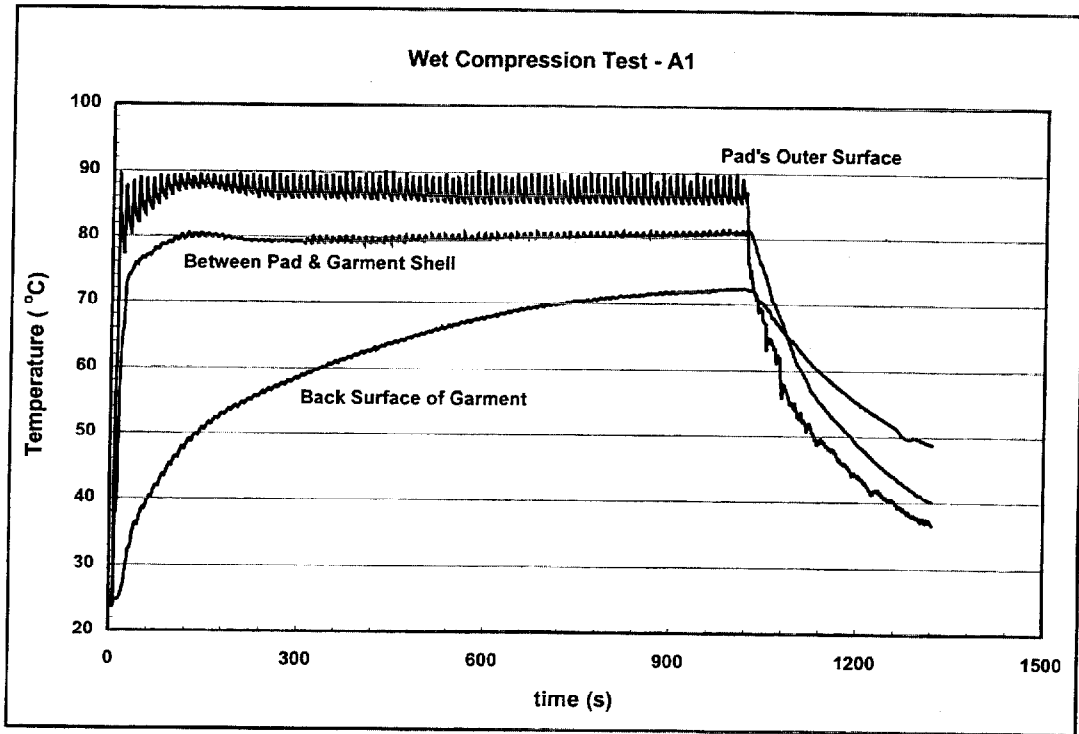

Figure 11 Example of data taken from a wet compression test.

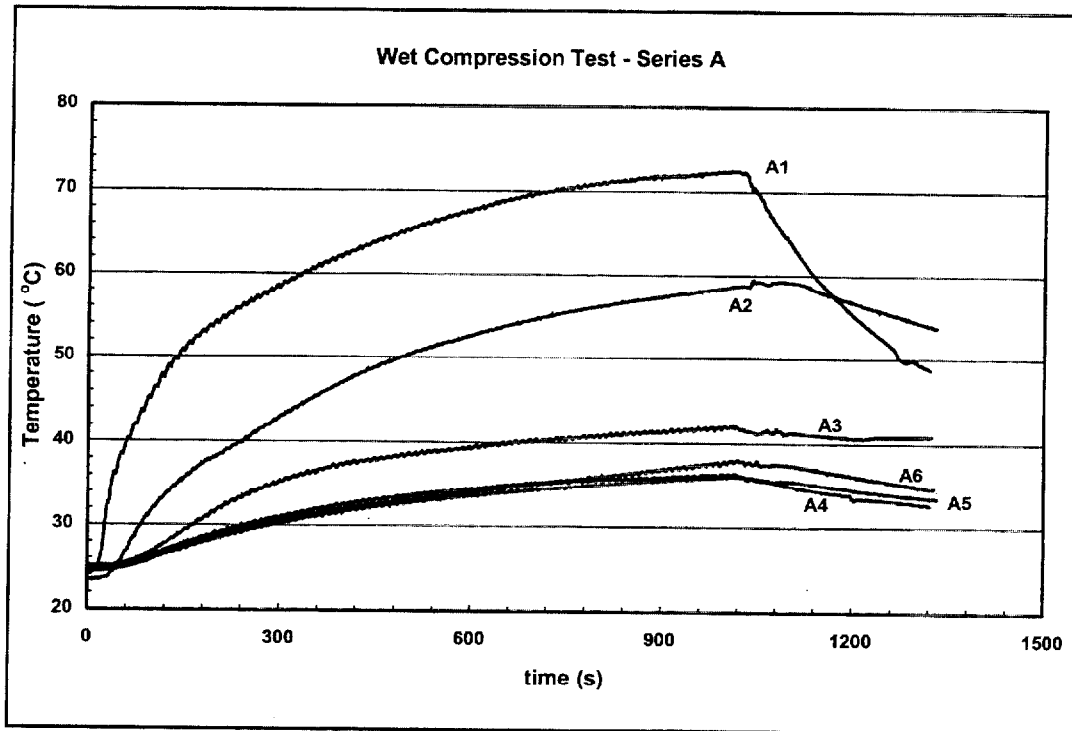

Figure 12 Wet compression test data for six different knee pad designs.

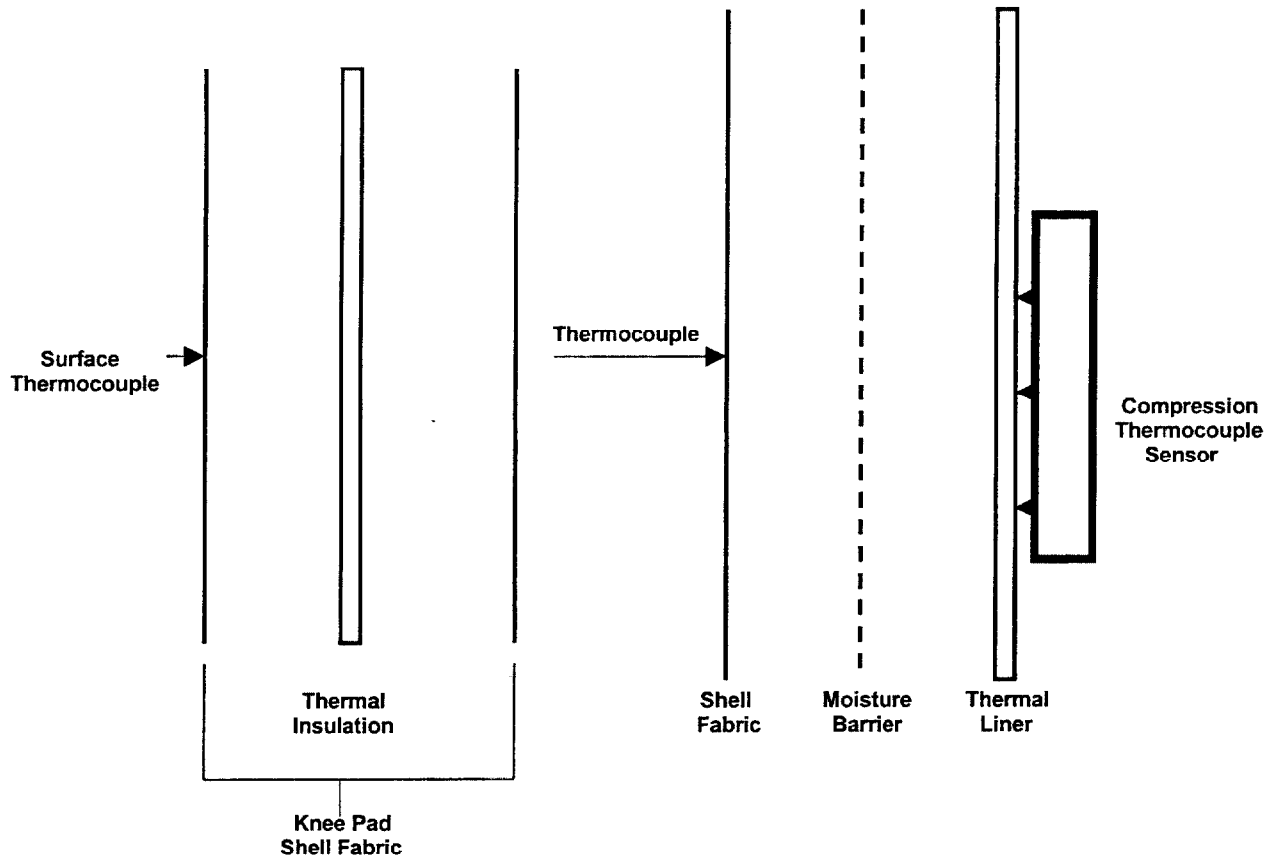

Figure 13 Garment and knee pad construction with temperature measurement locations.

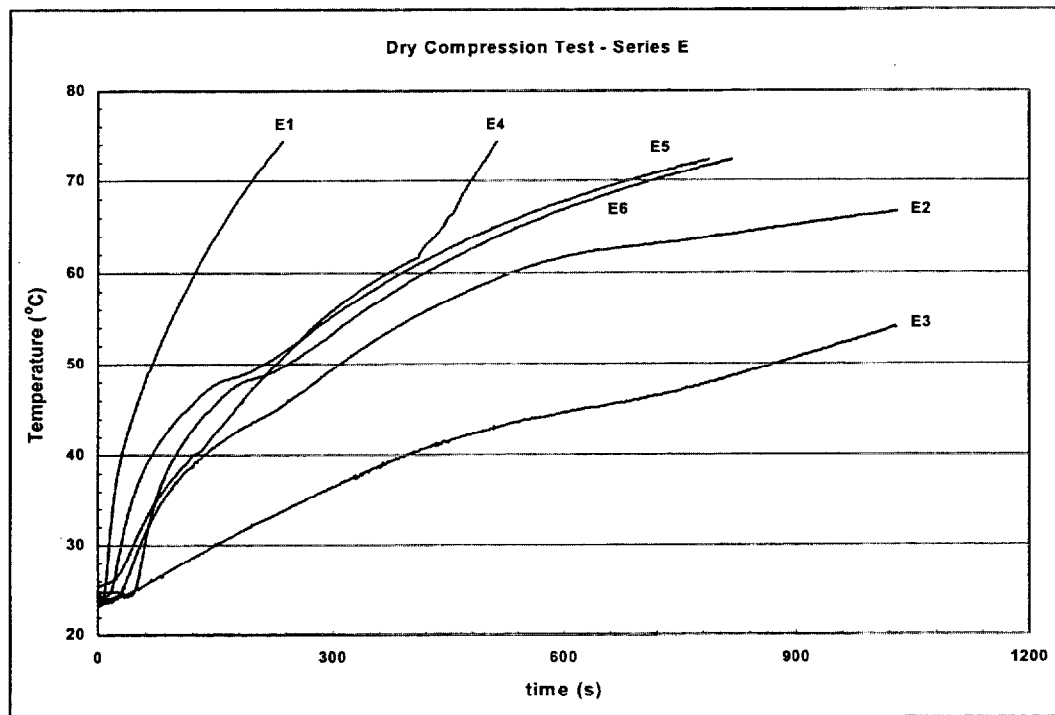
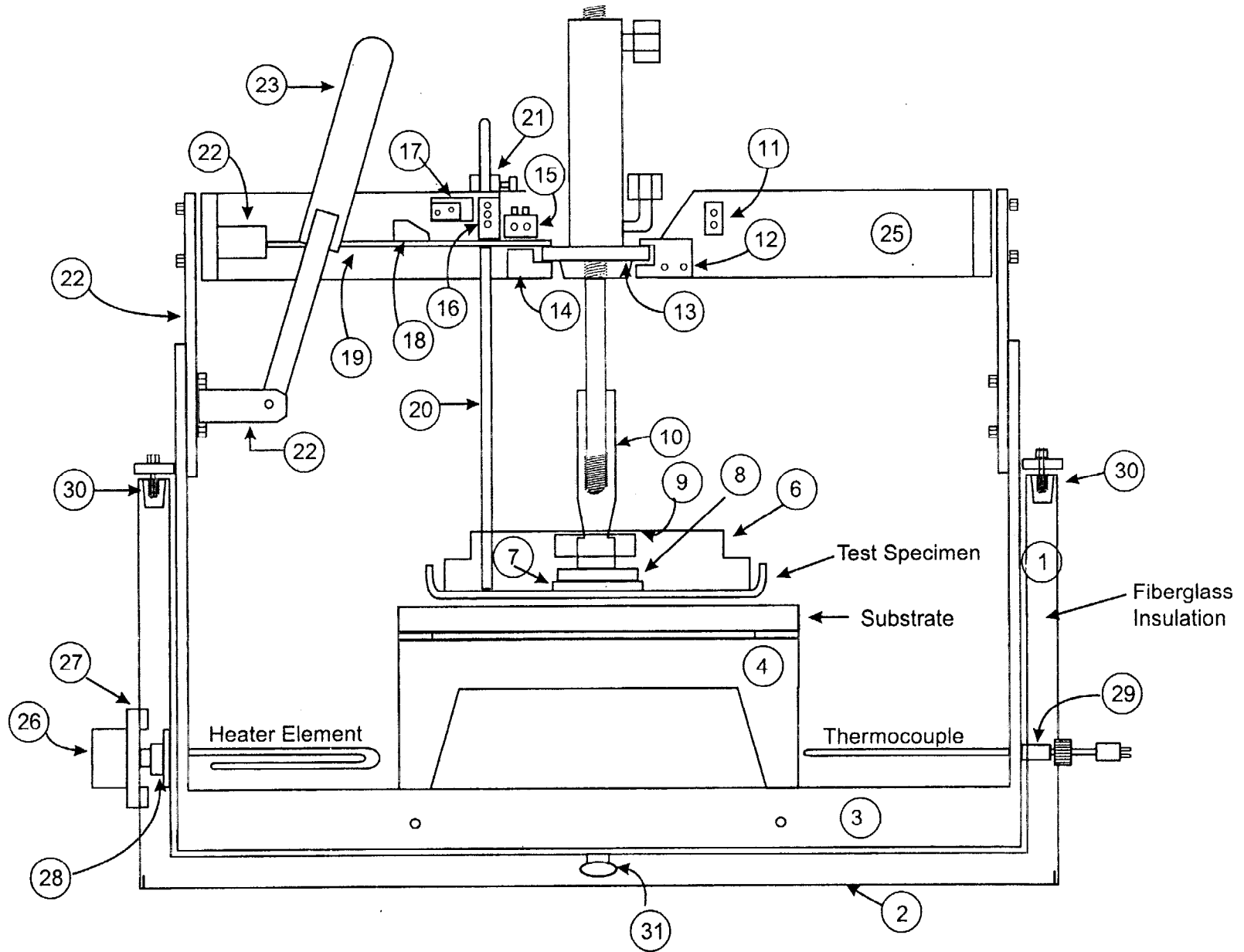

Figure 14 Dry compression test data for six different knee pad designs.

APPENDIX
ENGINEERING DRAWINGS
OF
COMPRESSION TEST APPARATUS

Parts List

Part Number	Item
1.	Stainless steel pan with insulating jacket
2.	Stainless steel base pan
3.	Base assembly
4.	Substrate support
5.	Height adjusting side plates
6.	Test specimen holder
7.	Sensor thermocouple locations, guide pin for sensor
8.	Force distributing block and latch pin
9.	Specimen holder lift clip
10.	Pneumatic cylinder rod extension
11.	Spacer (right side)
12.	Pneumatic cylinder support bracket assembly and drip pan
13.	Pneumatic cylinder support bracket
14.	Pneumatic cylinder support bracket base plate
15.	Pneumatic cylinder latch plate pressure assembly
16.	Spacer and sample holder alignment pin retaining knob
17.	Micro switch bracket
18.	Micro switch trigger block
19.	Pneumatic cylinder latch plate
20.	Specimen holder alignment pin
21.	Specimen holder alignment pin
22.	Latch plate actuating lever
23.	Pneumatic cylinder latch plate actuating lever
24.	Pneumatic cylinder latch plate guide
25.	Cross beam
26.	Heater element electrical cover
27.	Heater element electrical cover backing plate
28.	Heater element tank flanges
29.	Thermocouple tank flange
30.	Blind nut
31.	Inlet/drain water elbow, water diverter Water depth pointer and bracket Pneumatic circuit Electrical circuit layout



Stainless Steel Pan With Insulating Jacket Part No. 1

A3

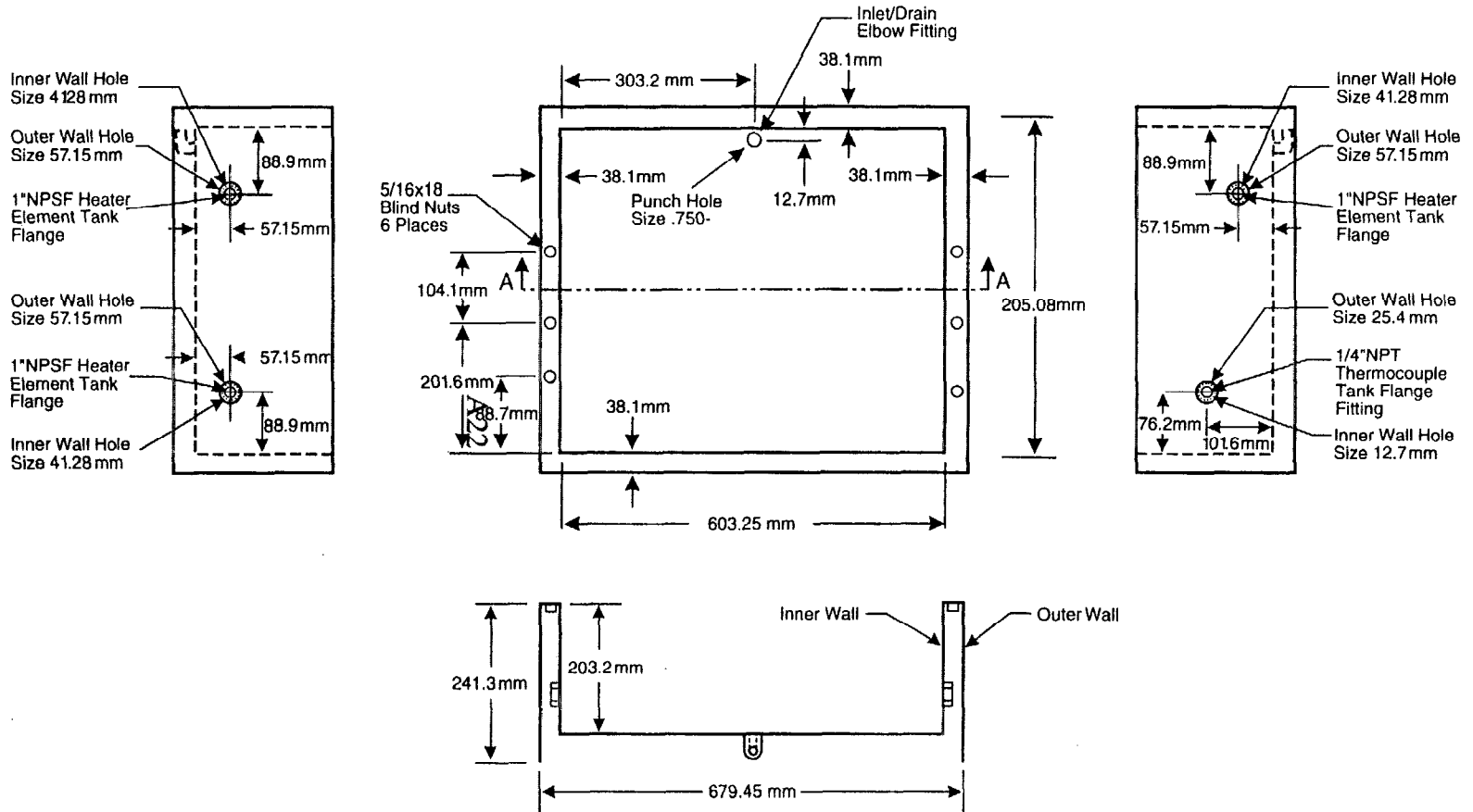

Material: 1.59mm Stainless Steel
Quantity: 1

Stainless Steel Base Pan Part Number 2

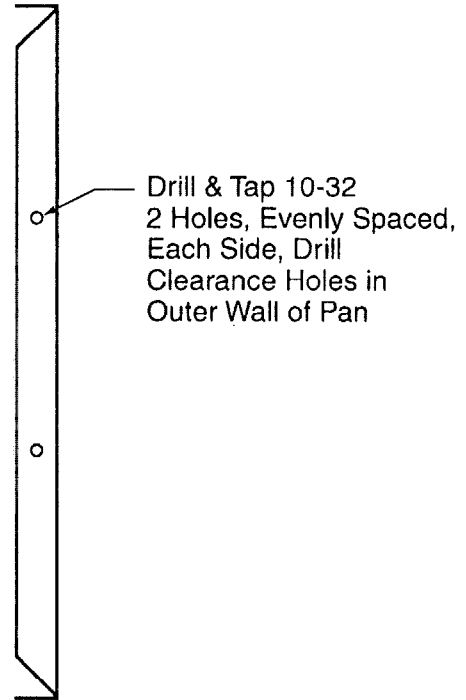
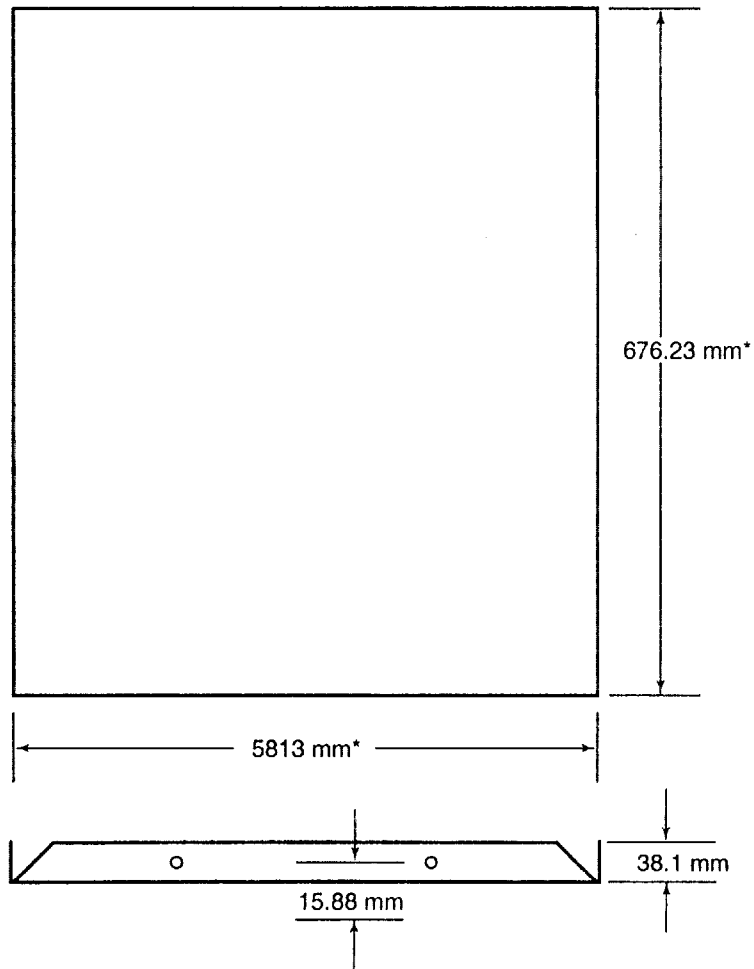

*Make Snug to Fit Inside Bottom
of S.S. Pan (Part #1)

Material: 16 ga. Stainless Steel
Quantity: 1

Base Assembly Part No. 3

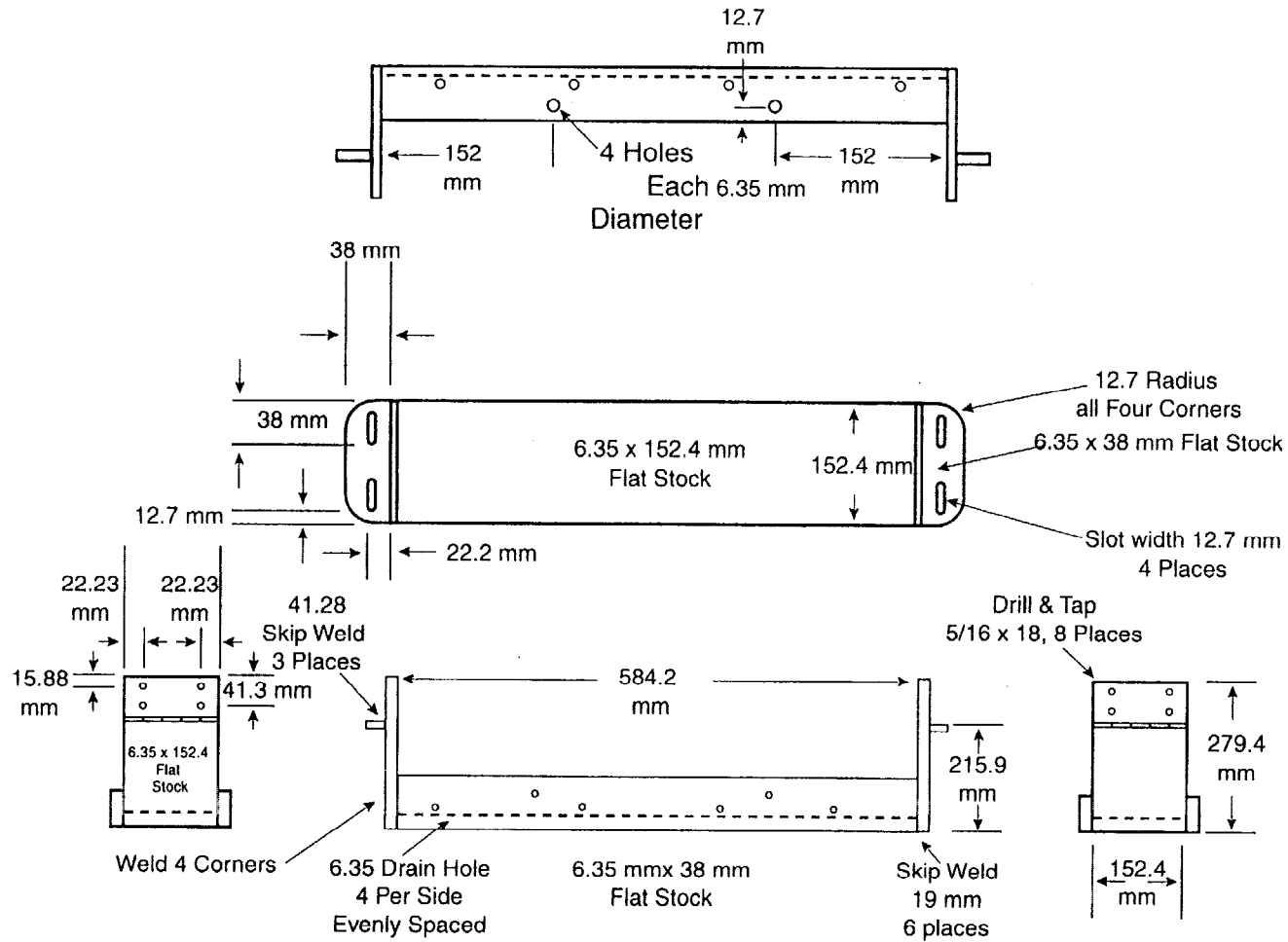

A5

Material: Stainless Steel
Quantity: 1

Substrate Support Part number 4

Drill & Tap 1/4 - 20
4 Places
Location: See note 1

Drill & Tap 10 - 32
4 Places

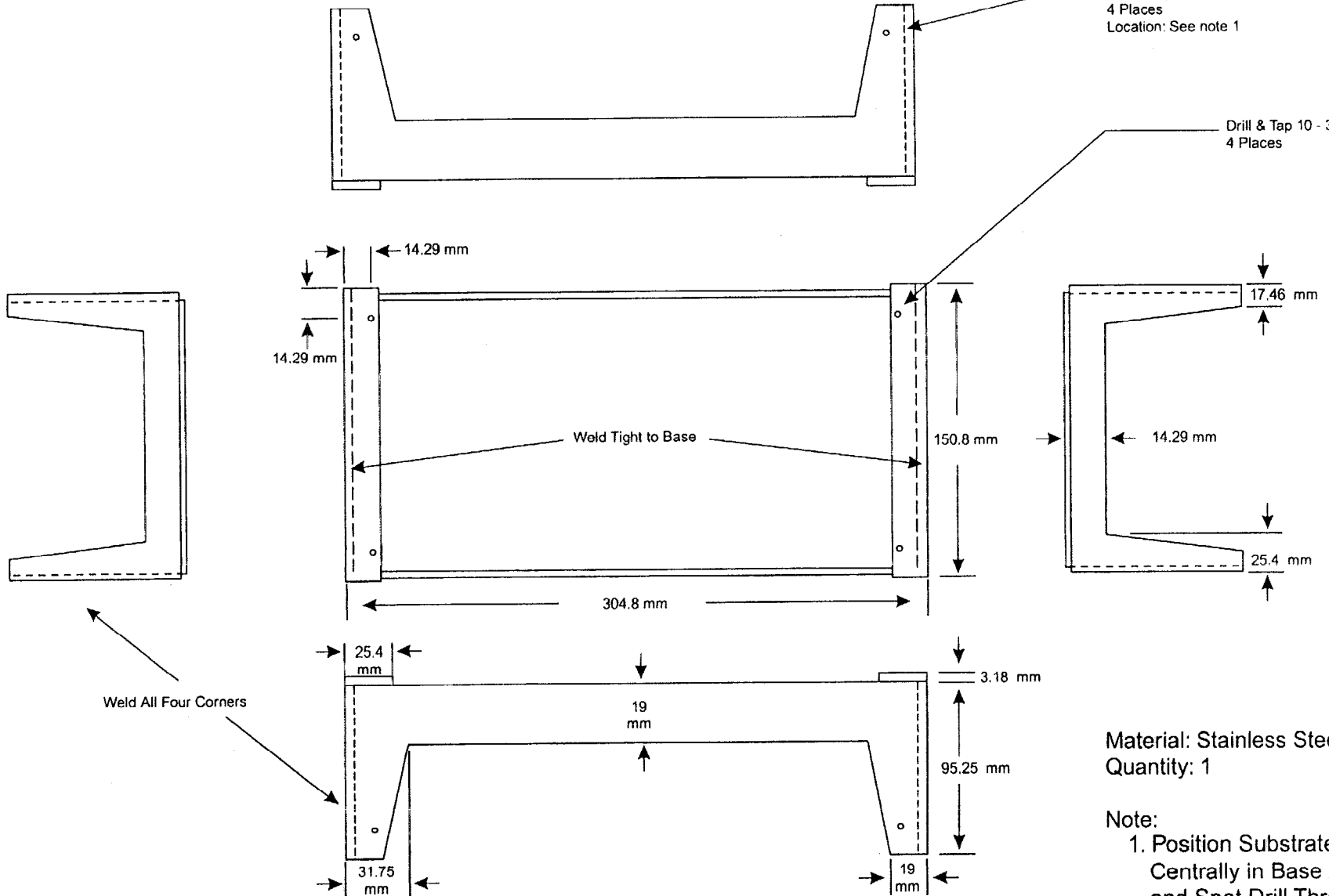

Material: Stainless Steel
Quantity: 1

Note:
1. Position Substrate Support
Centrally in Base Assembly
and Spot Drill Through Existing
Holes

A6

Height Adjusting Side Plates Part No. 5

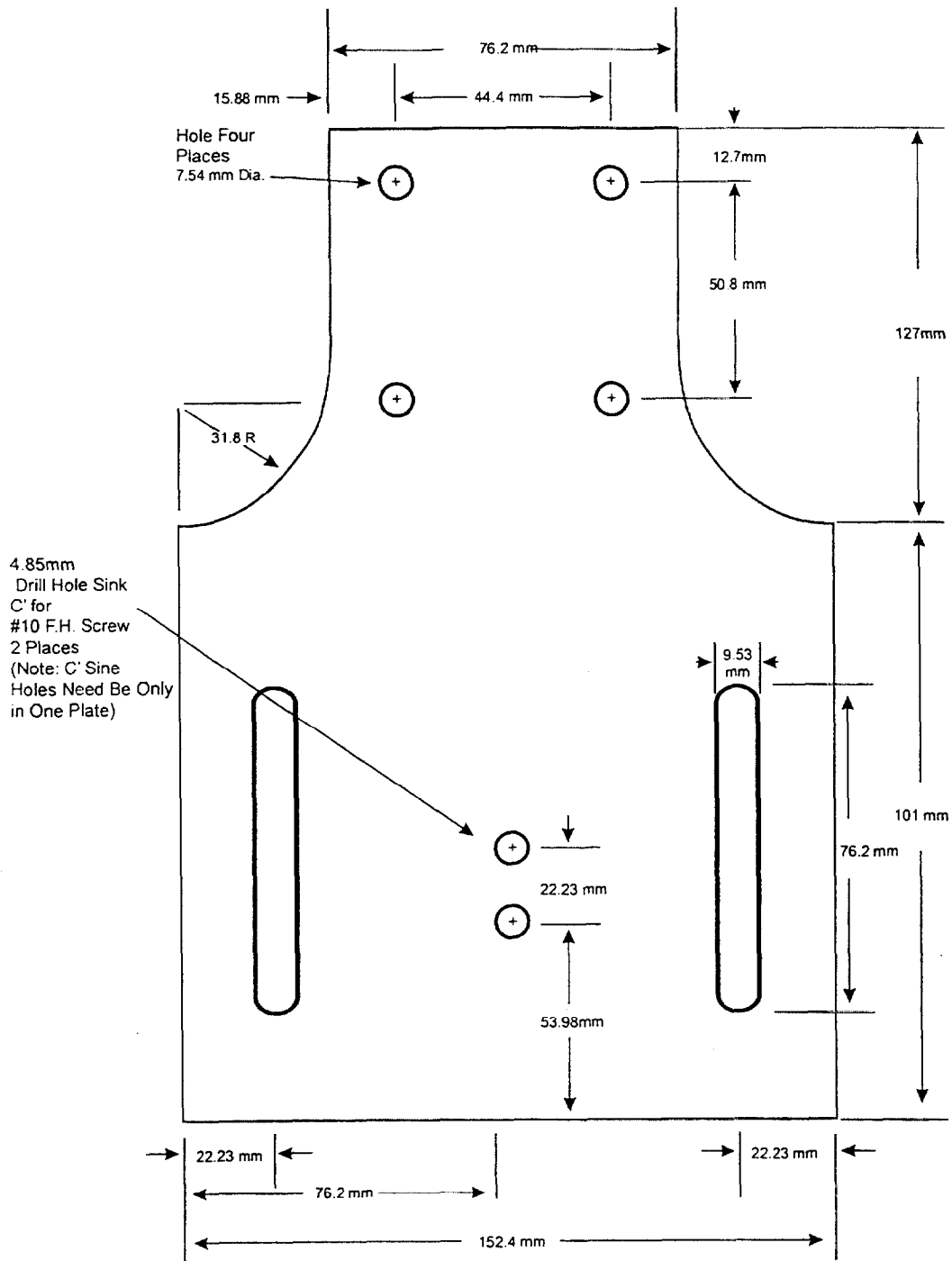

Material: Stainless Steel
Quantity: 2

Test Specimen Holder Part No. 6

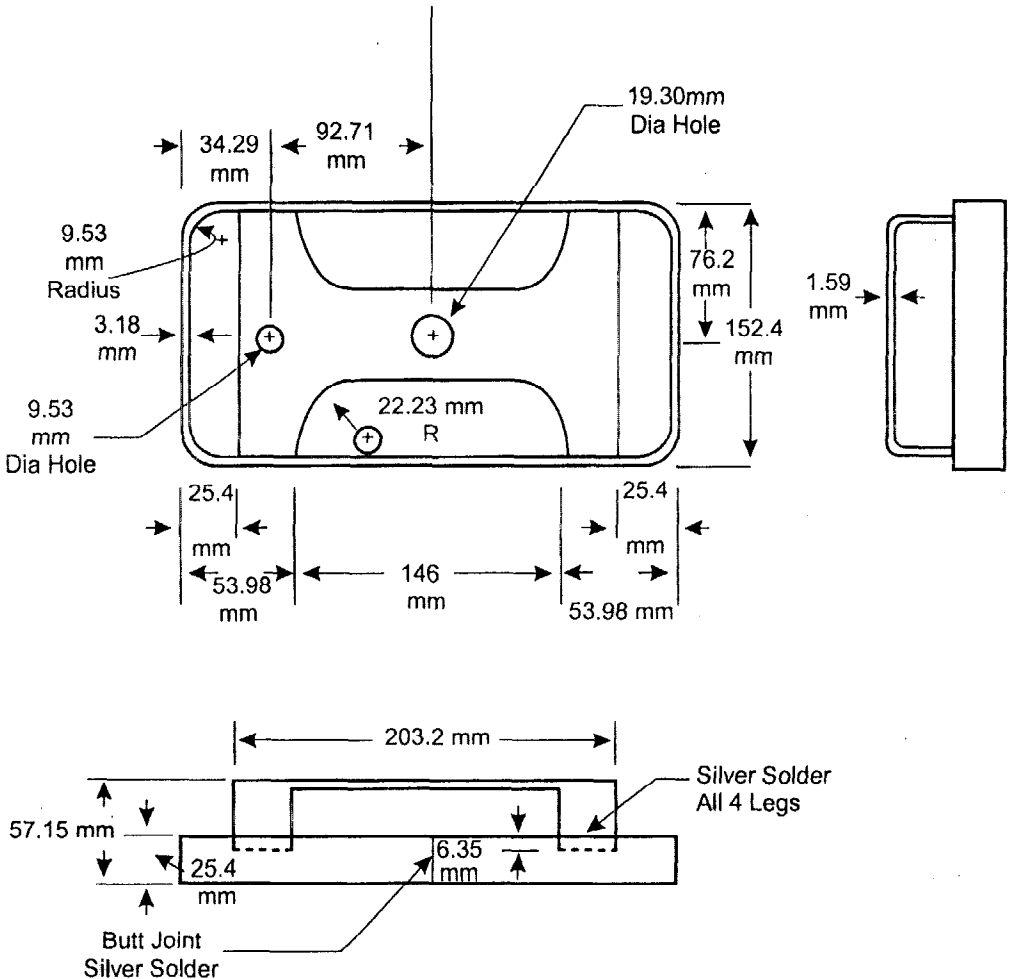

A8

Material: Brass
Quantity: 1

Sensor Thermocouple Location Side Facing Knee Pad Part No. 7

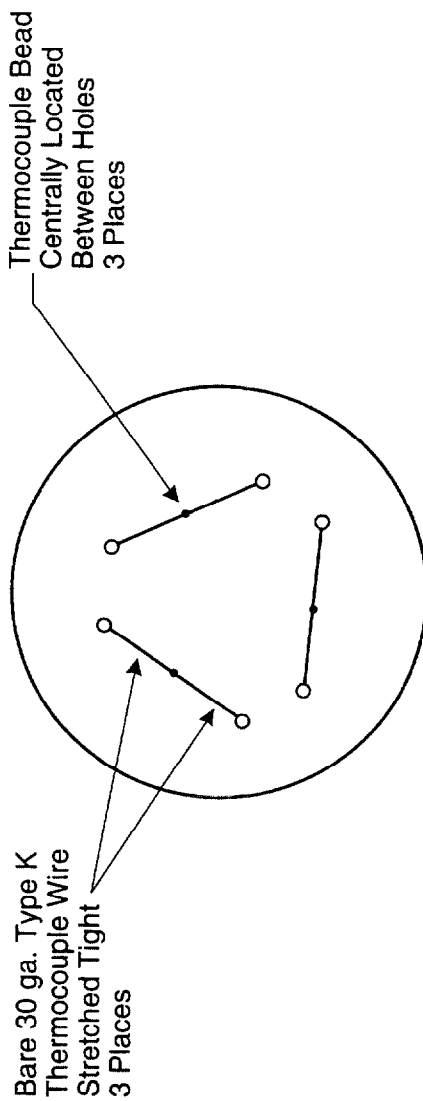

A10

Sensor Part No. 7

Material:
Bakelite Thermo
Setting Plastic
Type I, Cellulose
Paper Base
Grade, xx

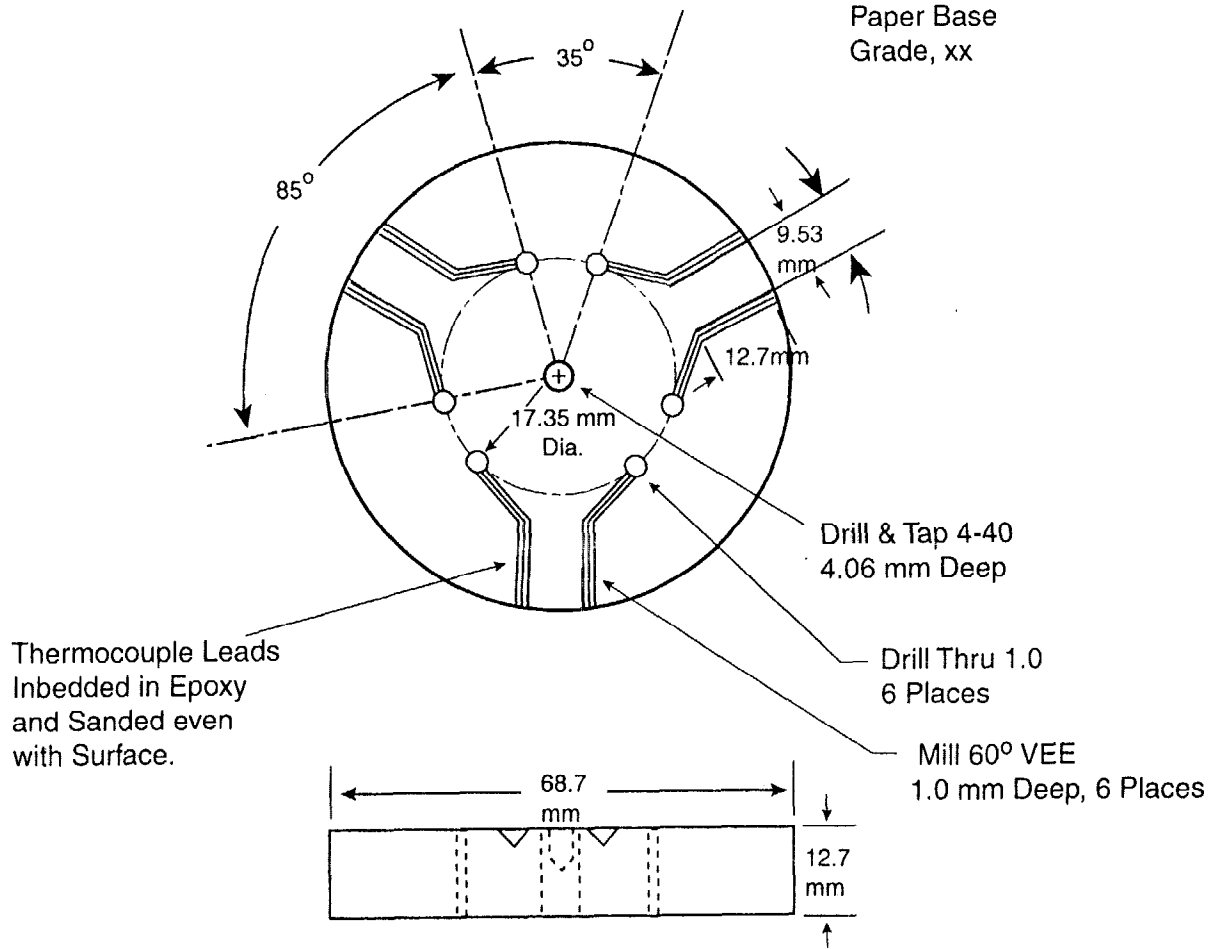

Guide Pin for Sensor

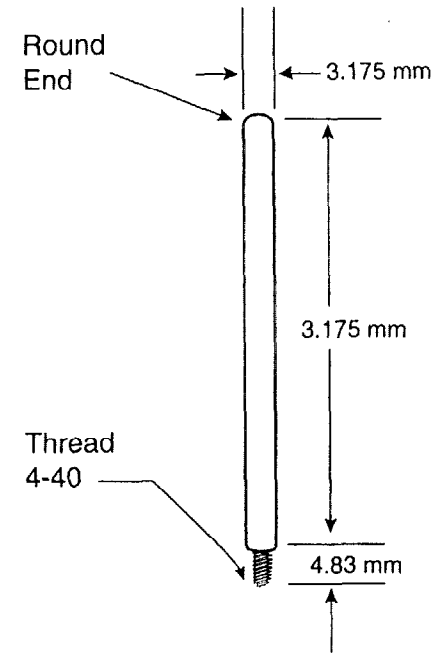

Material: Stainless Steel
Rod

Force Distributing Block Part Number 8

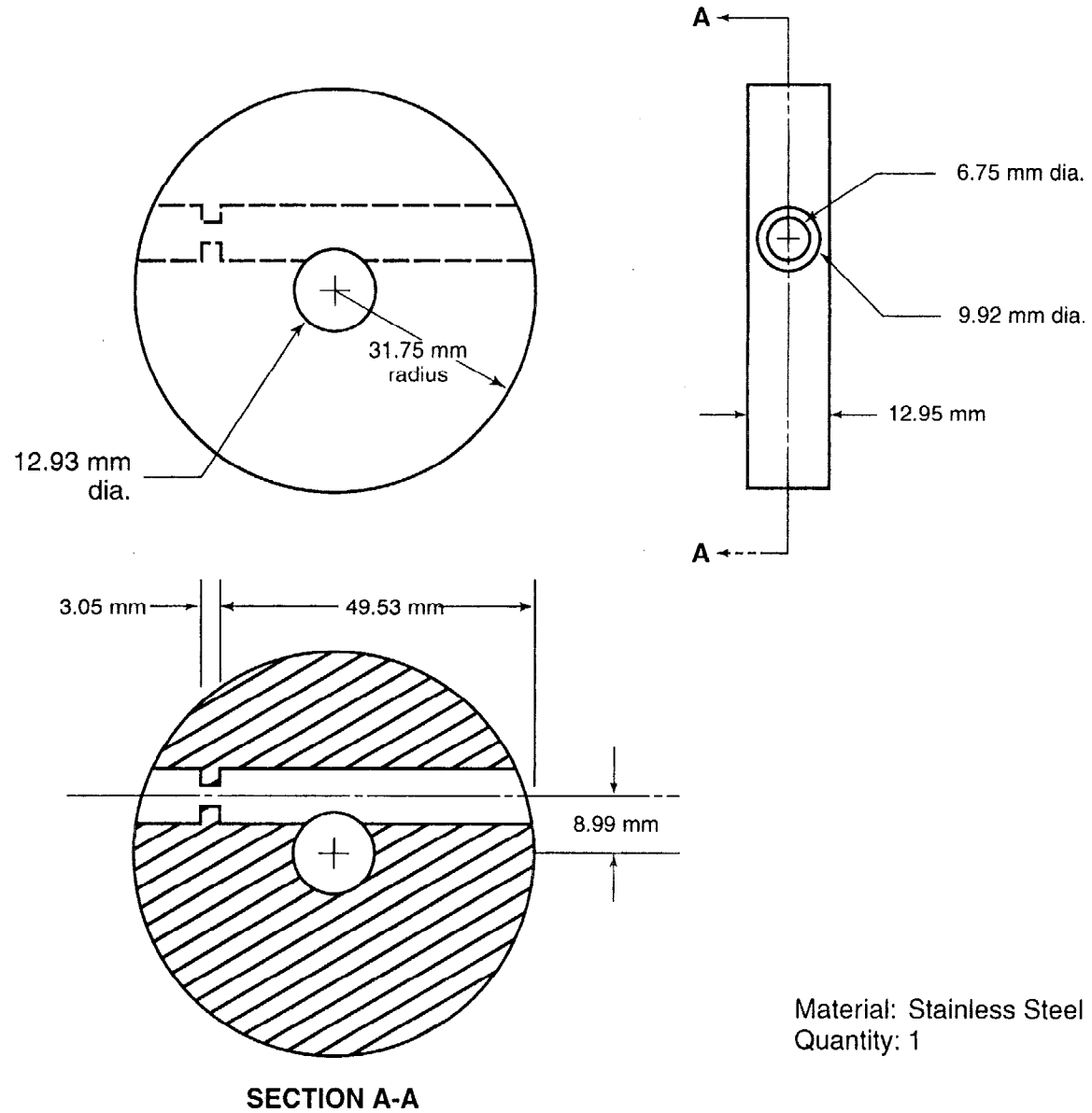

Material: Stainless Steel
Quantity: 1

Force Distributing Block Latch Pin Part of Part No. 8

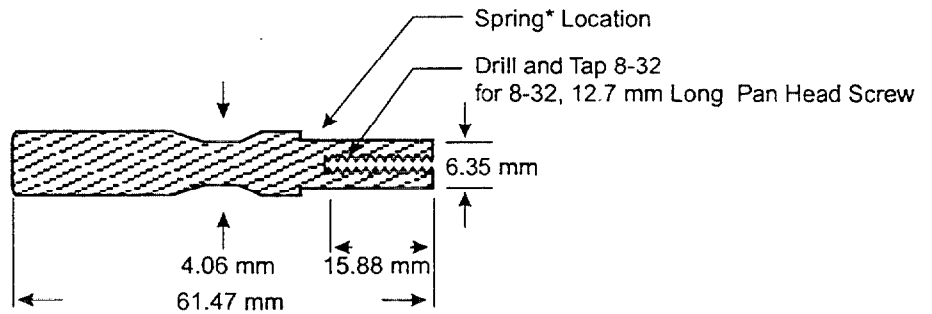
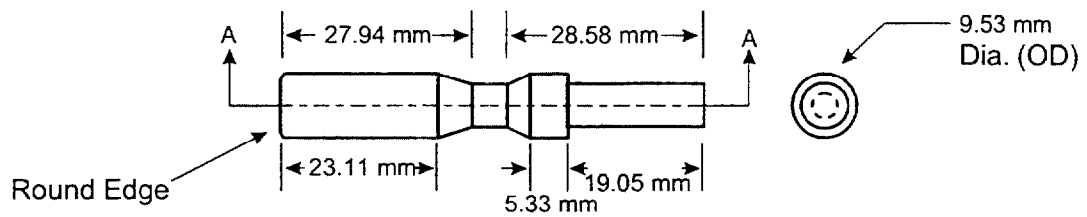

Section A-A

Material: Stainless Steel

Quantity: 1

*Spring: 6 Turn, ID. 6.60 mm, Wire Dia. .813 mm, S.S. Spring Tension Sufficient to Retain Force Dist. Block

Specimen Holder Lift Clip Part No. 9

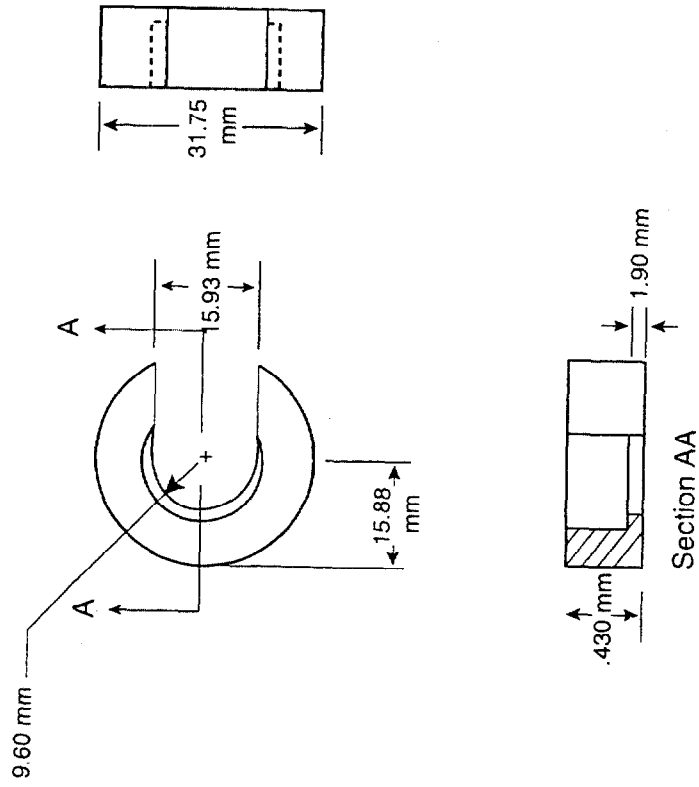

Material: Stainless Steel
Quantity: 1

Pneumatic Cylinder Rod Extension Part No. 10

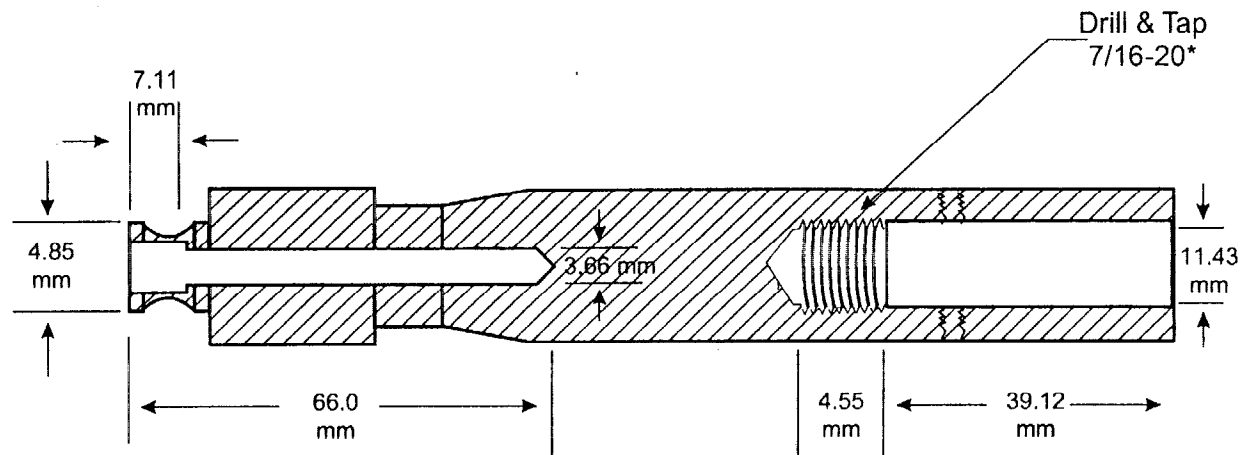
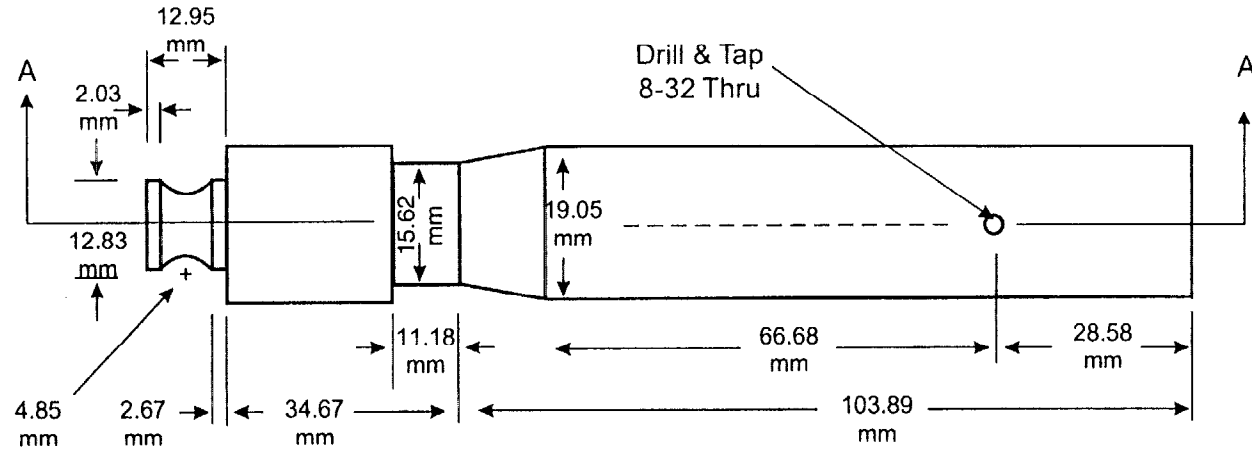

Note: Bore size and TAP
Size are for Use with
Grainger Pneumatic
Cylinder, Stock #6W145
Other Cylinders may Require
Different Bore & Threads

Material: 3/4' Stainless Steel
Quantity:

Spacer (right side)
Part No 11

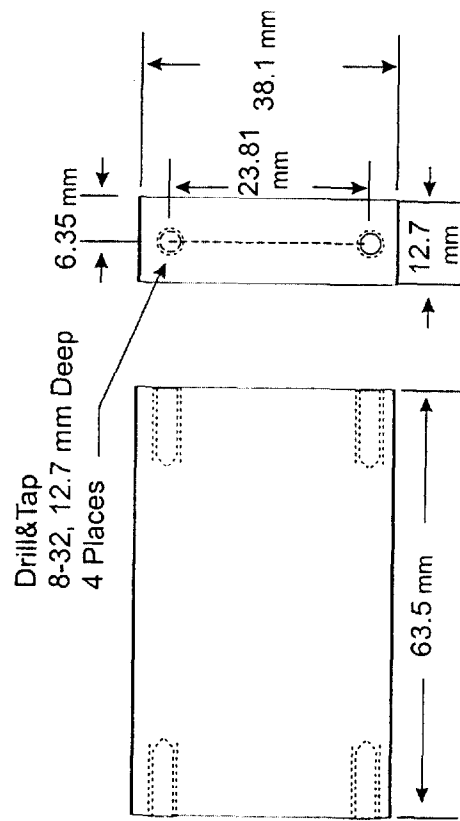

Material: Stainless Steel
Quantity: 1

Pneumatic Cylinder Support Bracket Plate (Right Side) Part No. 12

A16

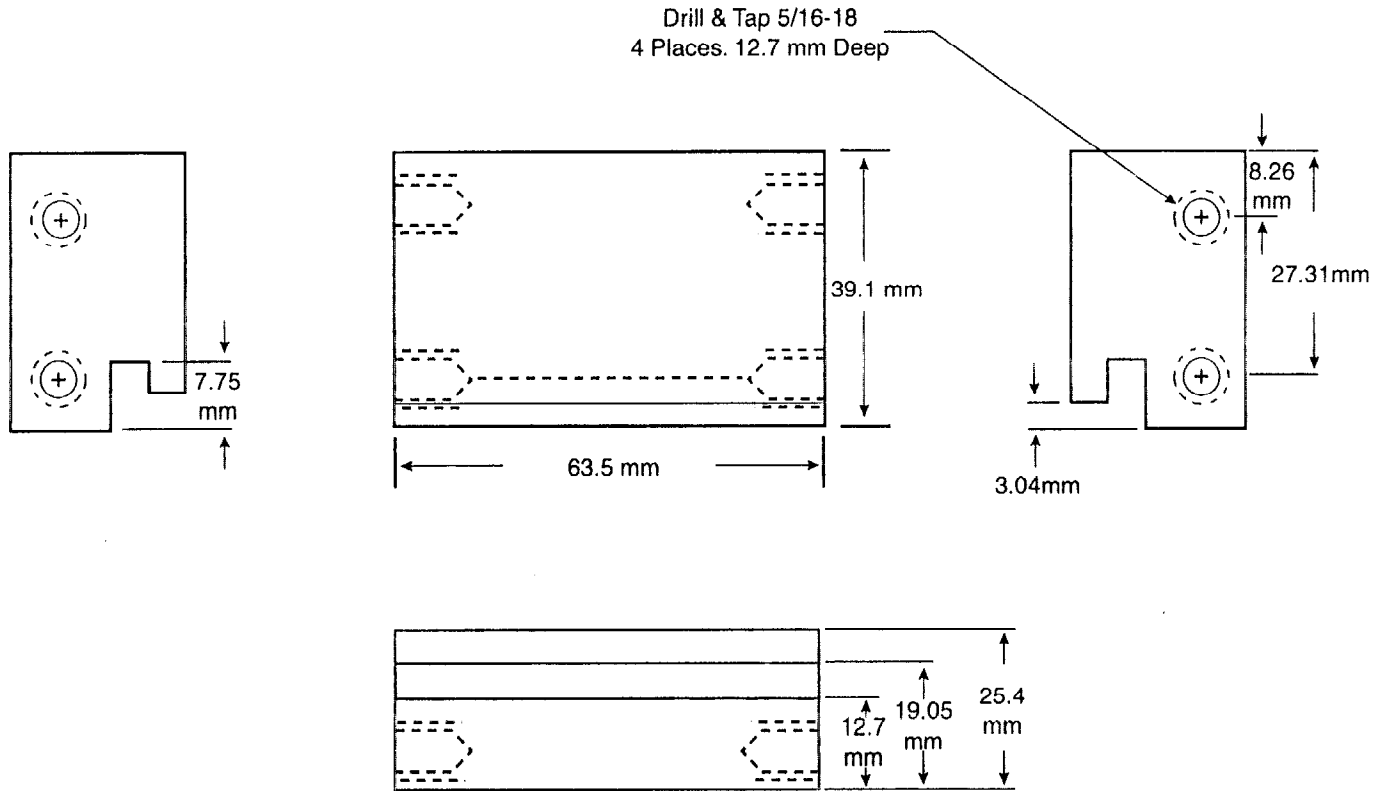

Material: Stainless Steel
Quantity: 1

Pneumatic Cylinder Specimen Holder Drip Pan

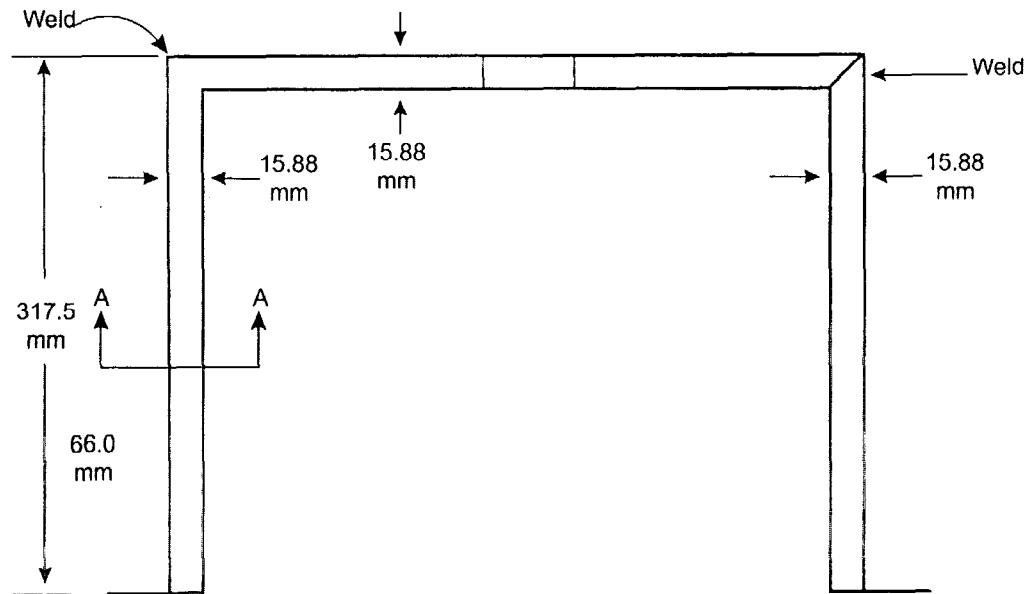
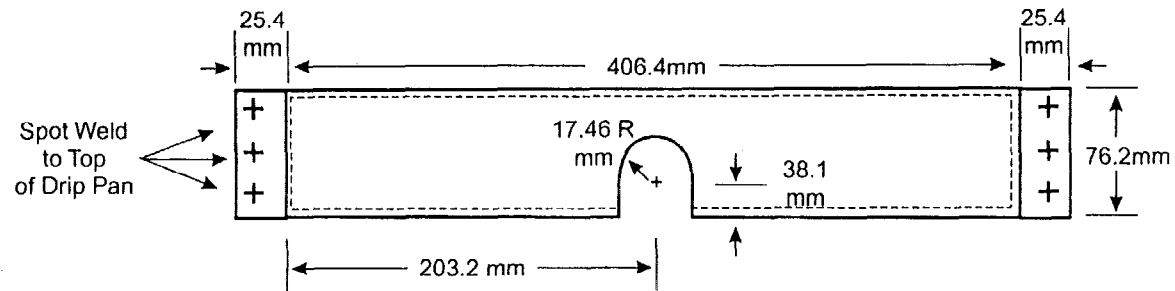

Section A-A

Material: 1.59 mm Stainless Steel
Quantity: 1

A17

Drip Pan

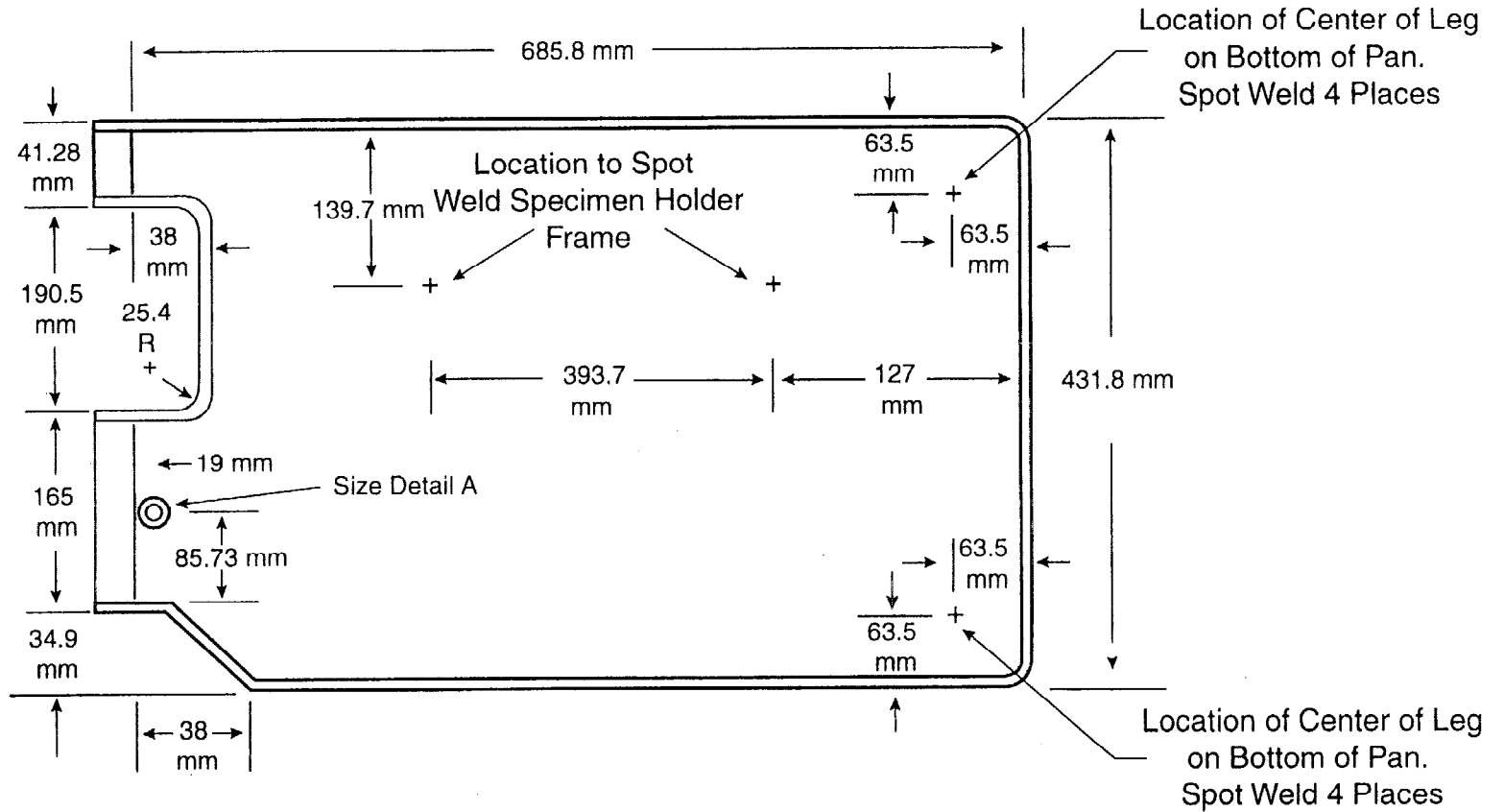

A18

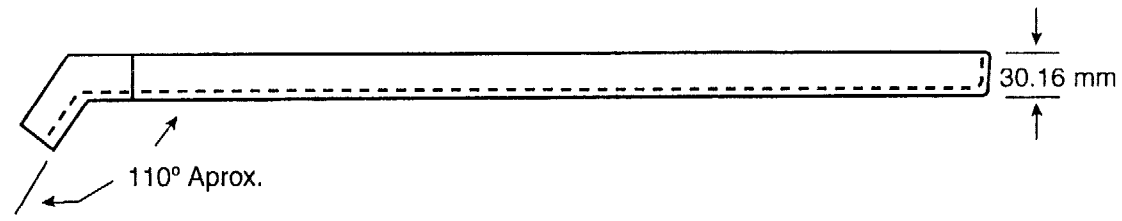
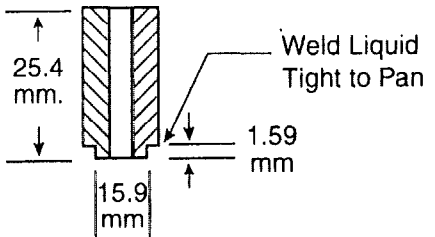
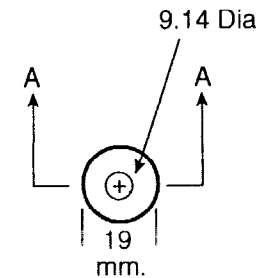

Detail "A"
Mount Water Depth
Pointer Bracket to Top
with 5/16-18 + 1 1/2 Bolt

Material: 1.59 mm Stainless Steel Sheet
Quantity: 1

Drip Pan Legs

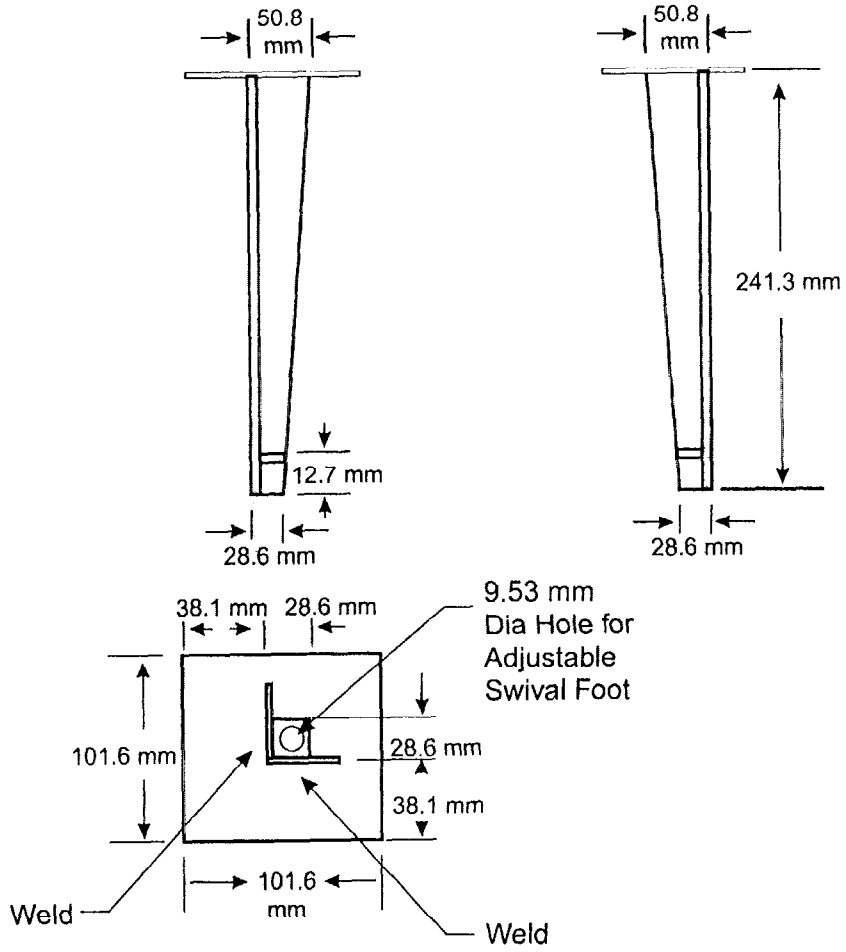

Material: 1.59mm Stainless Steel Sheet
Quantity: 2

Pneumatic Cylinder Support Bracket Part No. 13

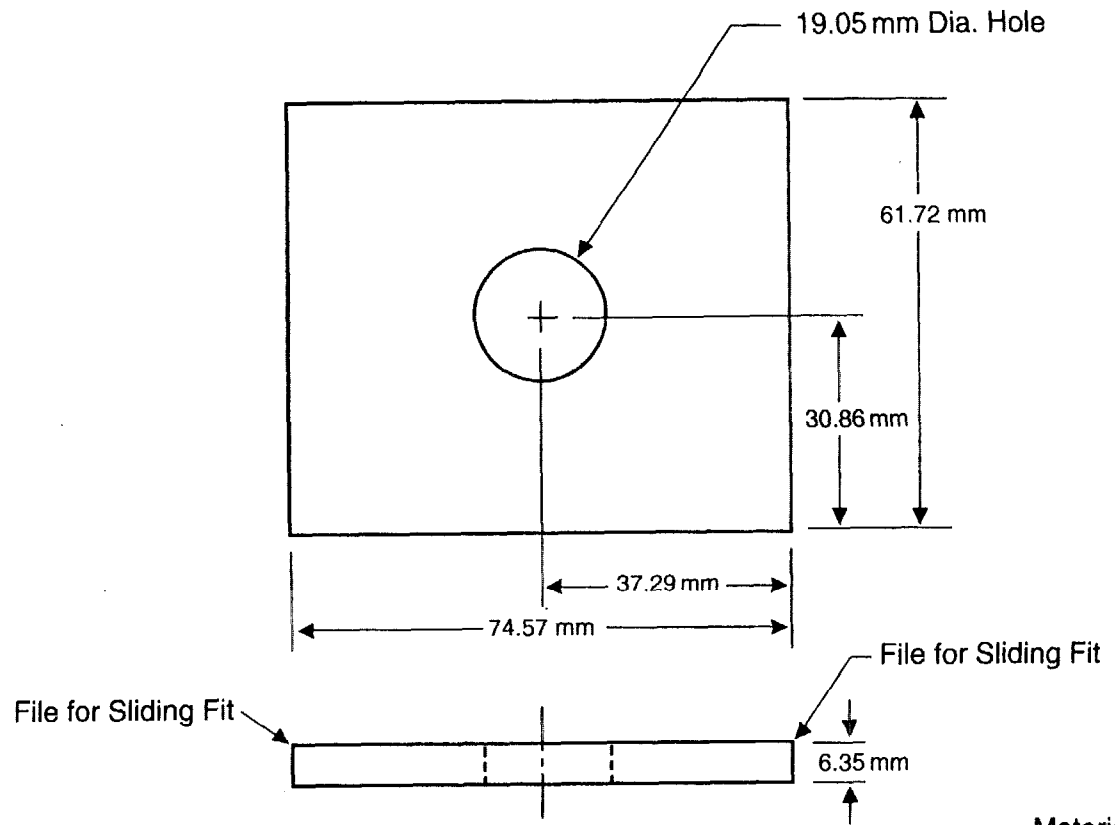

Material: Stainless Steel
Quantity: 1

A20

Pneumatic Cylinder Support Bracket Base Plate (Left Side) Part No. 14

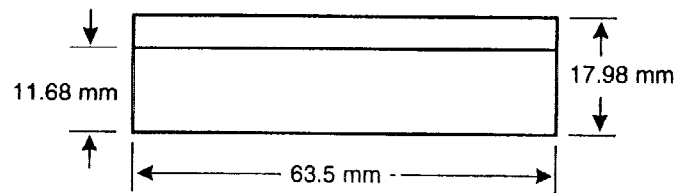
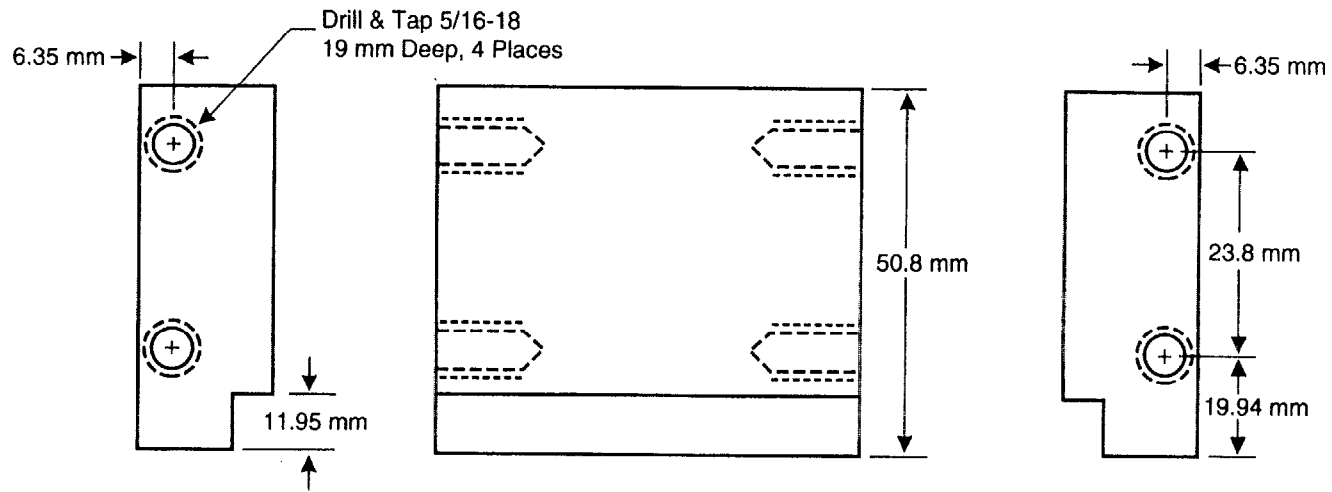

Material: Stainless Steel
Quantity: 1

A21

Pneumatic Cylinder Latch Plate Pressure Assembly Part No. 15

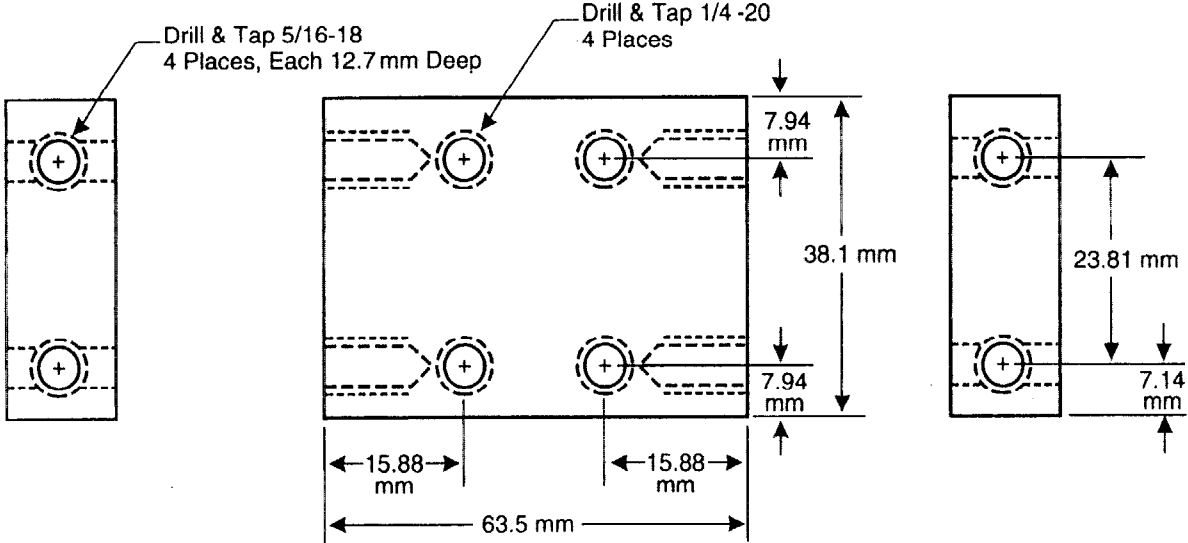

Material: Stainless Steel
Quantity: 1

Spacer Part No.16

A23

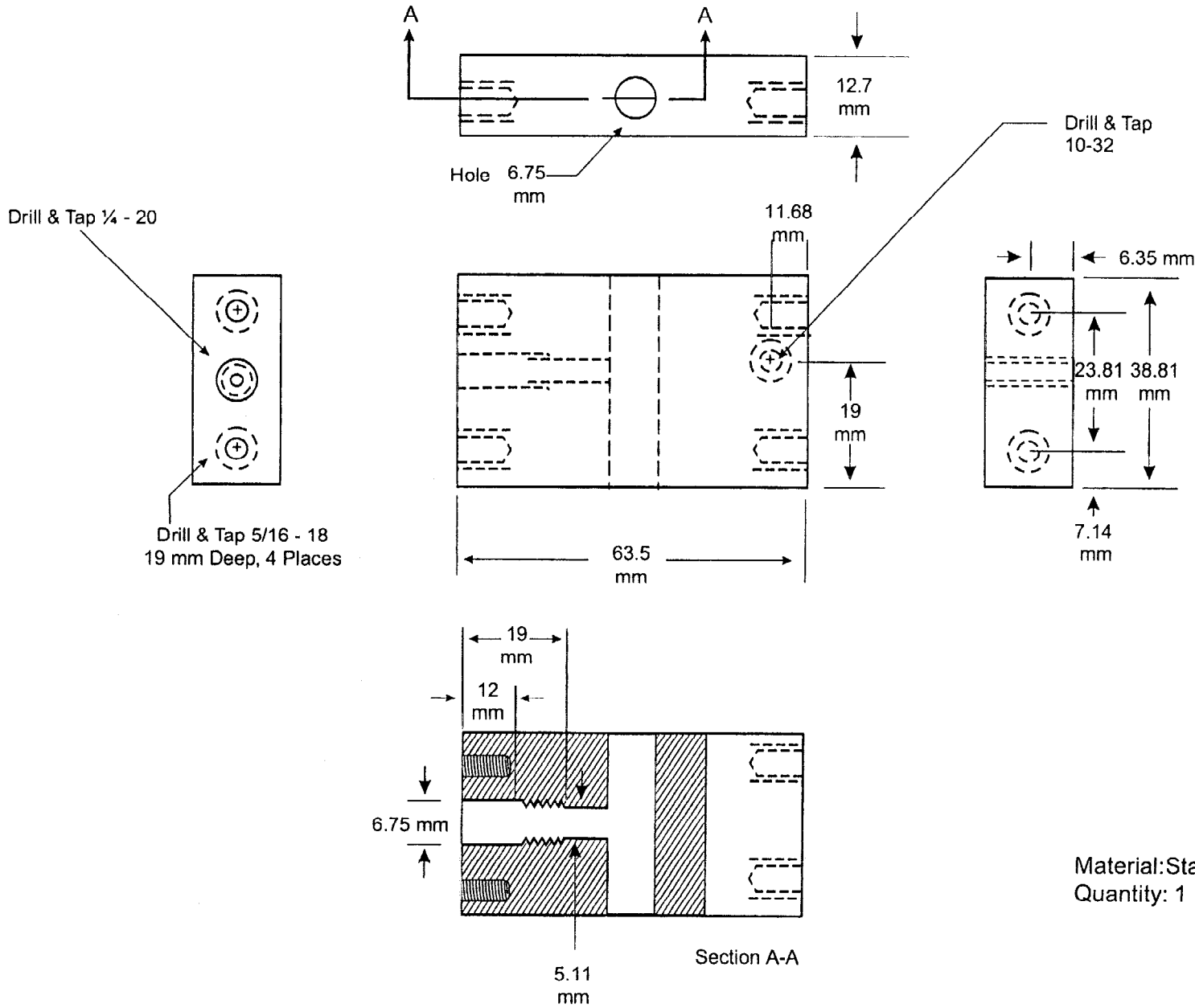

Material: Stainless Steel
Quantity: 1

Sample Holder Alignment Pin
Retaining Knob
Fits in Part No. 16

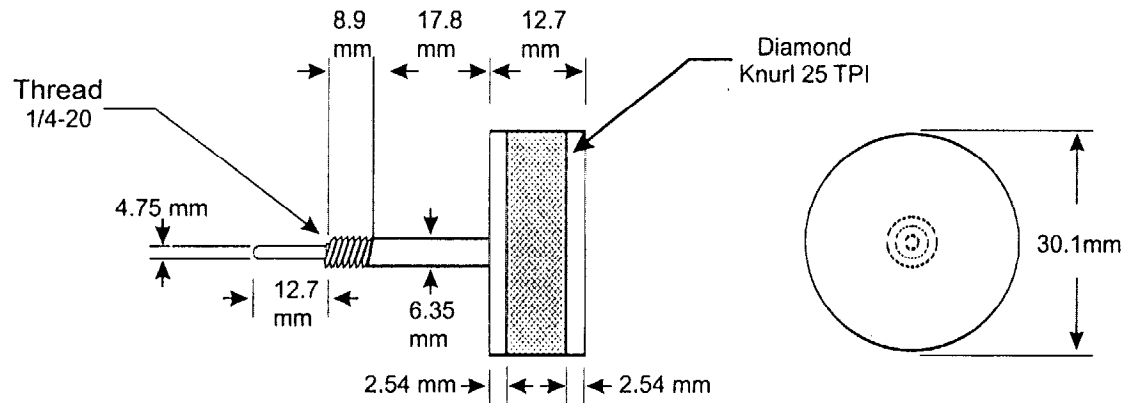

A24

Material: Stainless Steel
Quantity: 1

Micro Switch Bracket Part Part No. 17

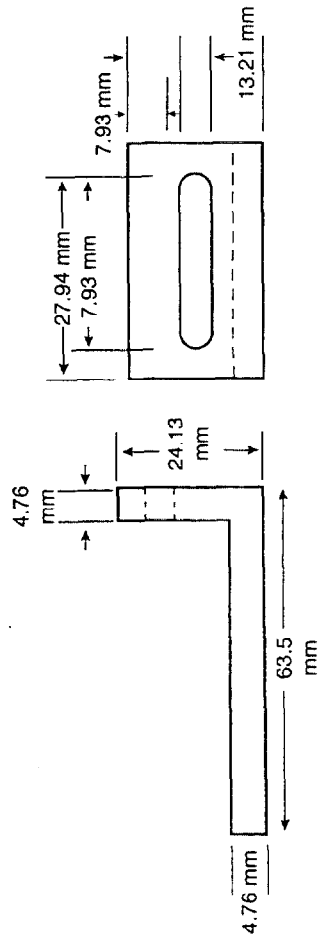

Drill & Tap
2 Places

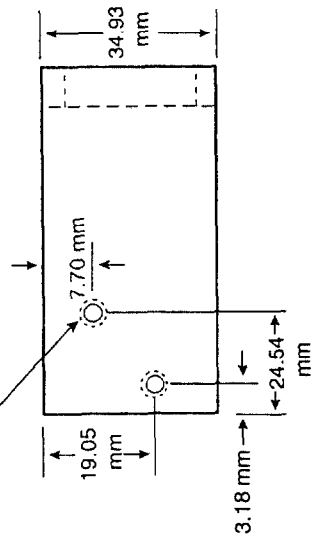

Material: Stainless Steel
Quantity: 1

Micro Switch Trigger Block Part No. 18

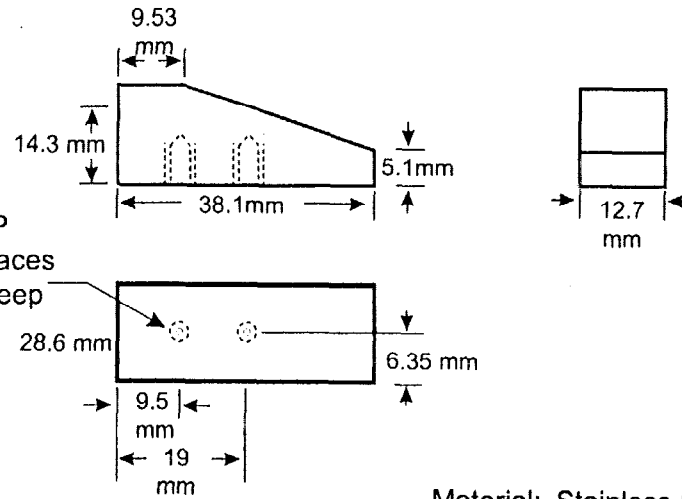

Drill & TAP
6-32, 2 Places
7.9 mm Deep

Material: Stainless Steel
Quantity: 1

Pneumatic Cylinder Latch Plate

Part number 19

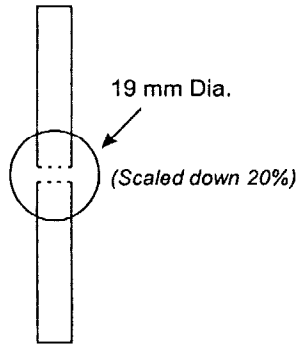

6.35 mm
End view

Small Radius 4 Corners

A27

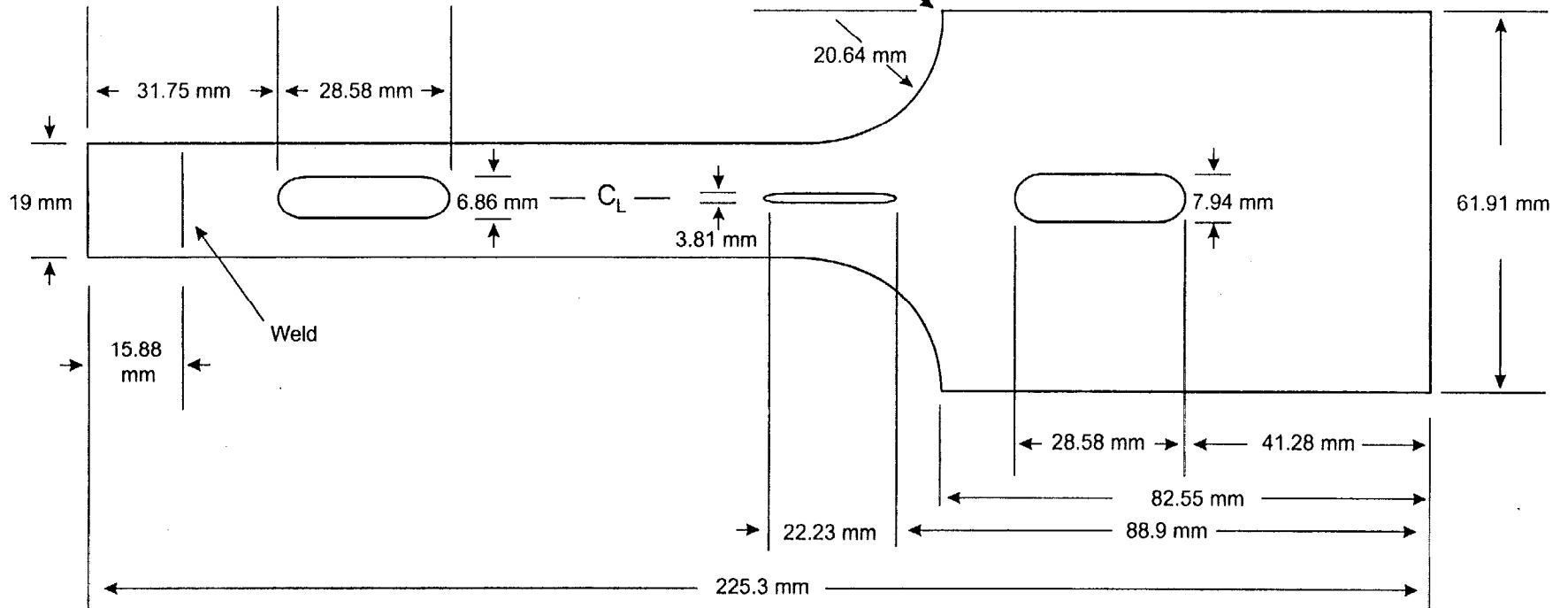

Material: Stainless Steel
Quantity: 1

**Specimin Holder Alignment Pin
No. 20**

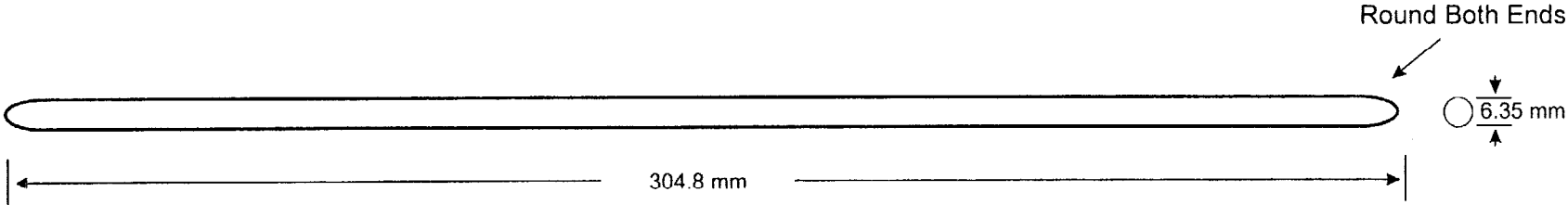

A28

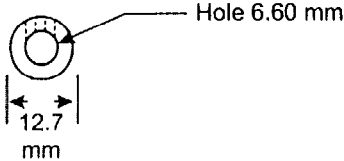
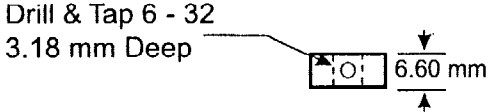

Material: Stainless Steel
Quantity: 1 Each

**Specimin Holder Alignment Pin
No. 21**

Latch Plate Actuating Lever Pivot Block Part No. 22

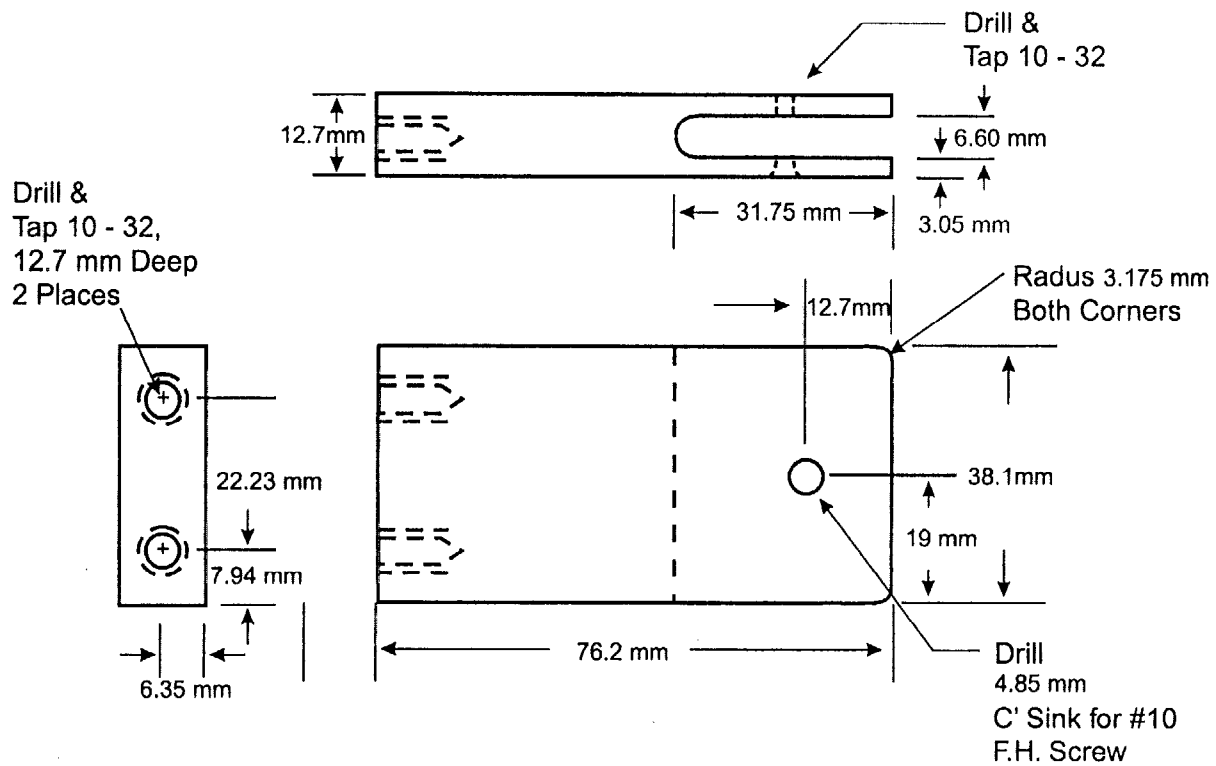

Material: Stainless Steel
Quantity: 1

Pneumatic Cylinder Latch Plate Actuating Lever Part No. 23

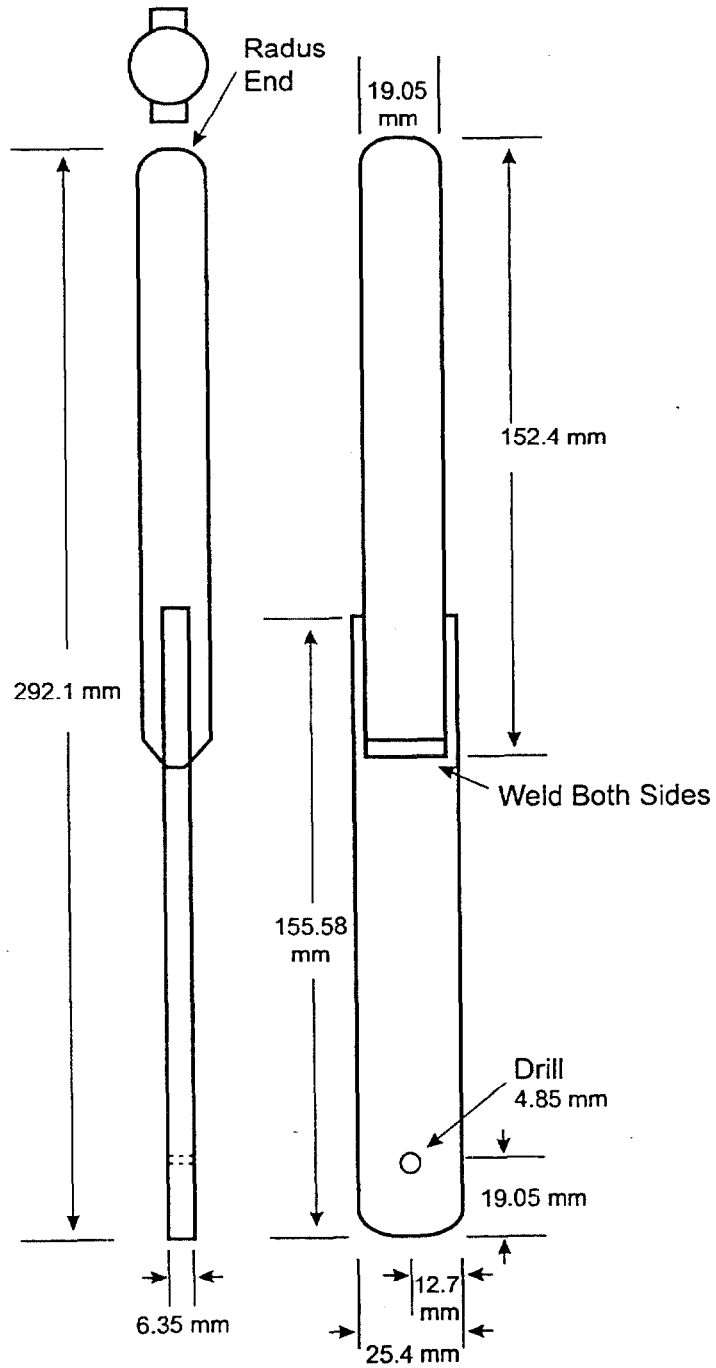

Material: Stainless Steel
Quantity: 1

Pneumatic Cylinder Latch Plate Guide Part Number 24

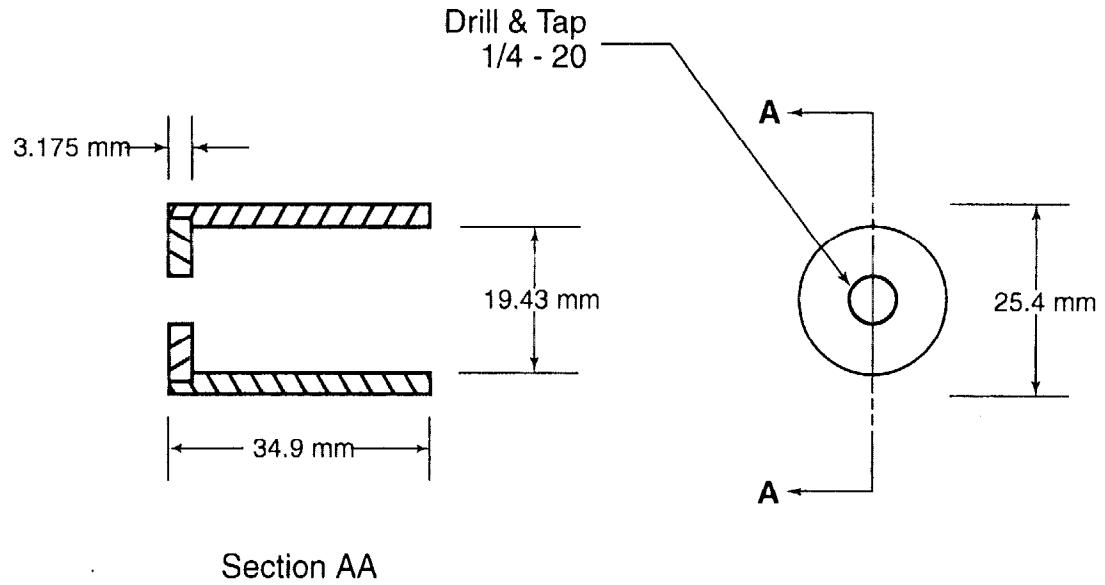

A31

Material: Stainless Steel
Quantity: 1

Cross Beam Part No. 25

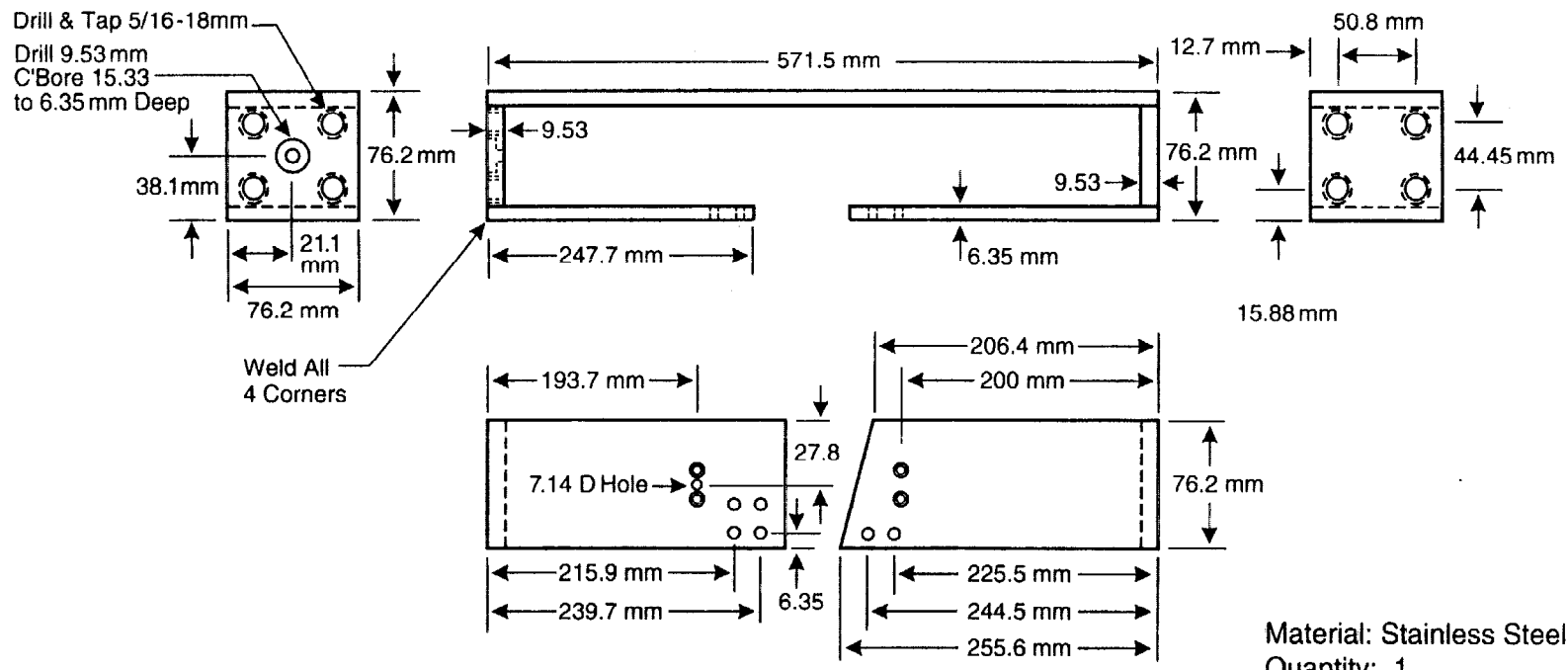
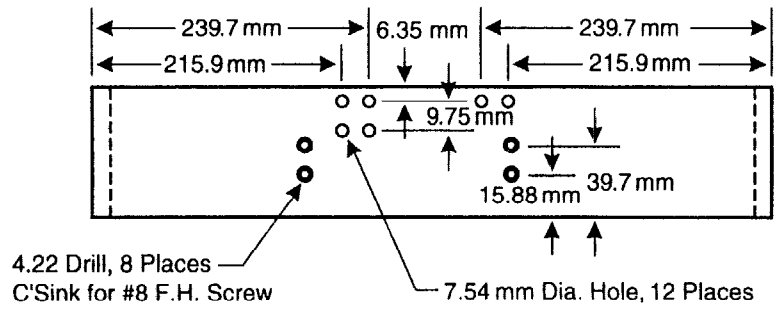

Material: Stainless Steel
Quantity: 1

A32

Heater Element Electrical Cover Part Number 26

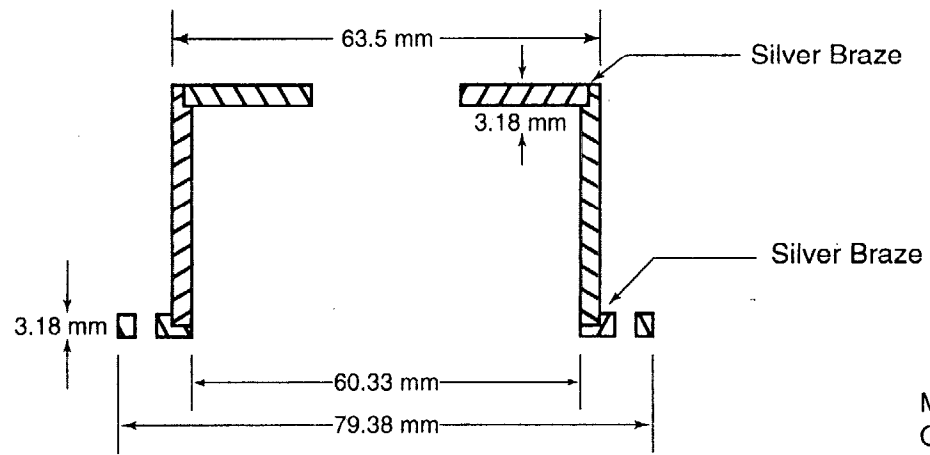
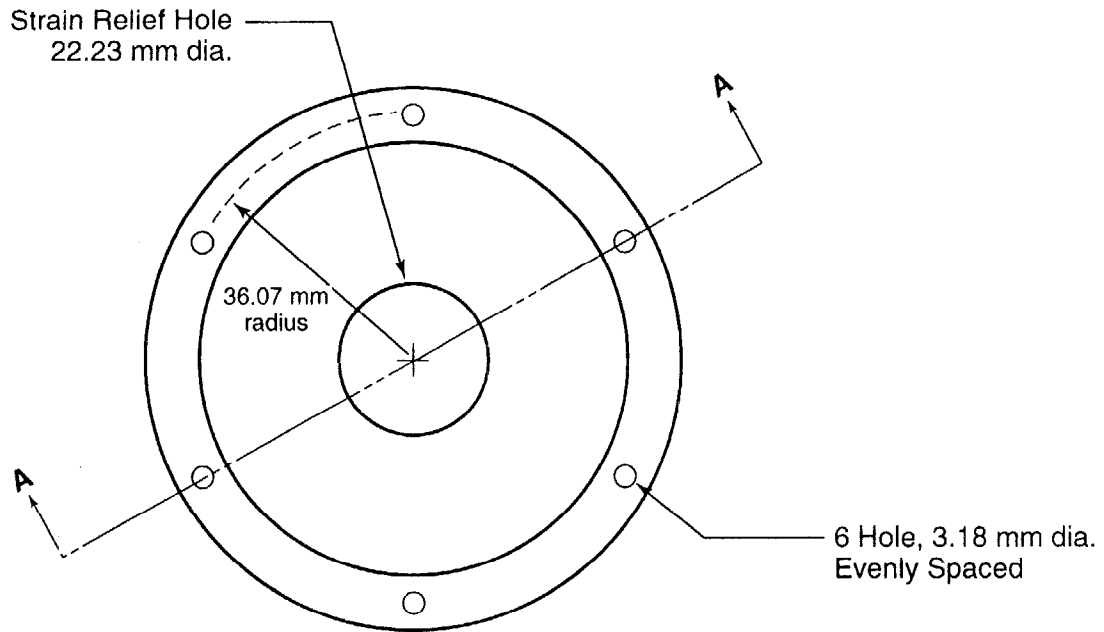

SECTION A-A

Material: Stainless Steel
Quantity: 3

Heater Element Electrical Cover Backing Plate Part Number 27

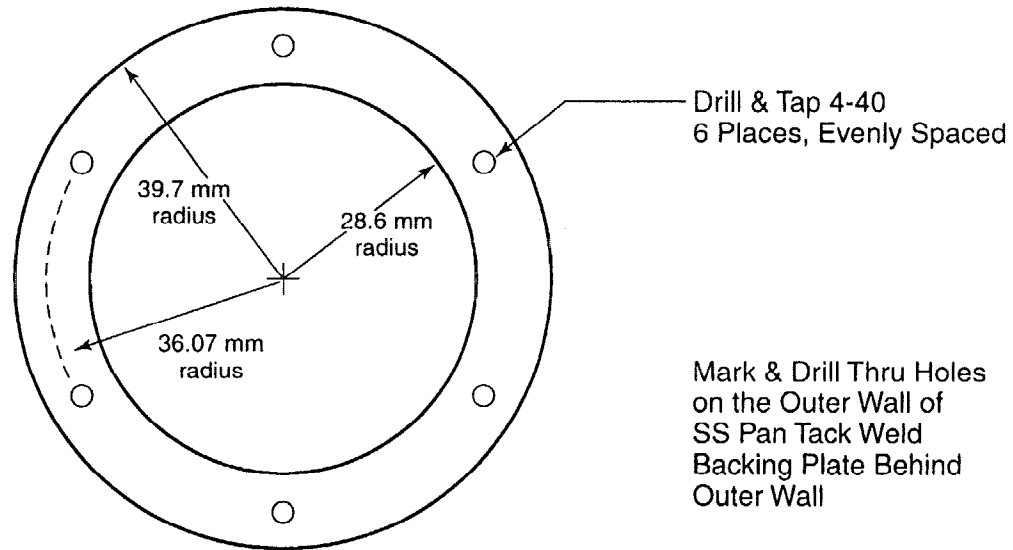

Mark & Drill Thru Holes
on the Outer Wall of
SS Pan Tack Weld
Backing Plate Behind
Outer Wall

Material: 3.18 mm Stainless Steel
Quantity: 3

Heater Element Tank Flanges Part Number 28

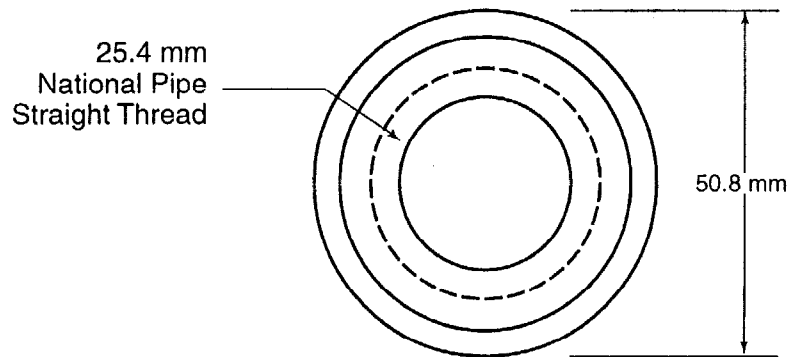
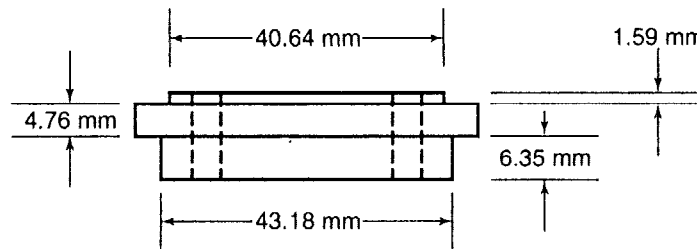

Material: Stainless Steel
Quantity: 3

Thermocouple Tank Flange Part Number 29

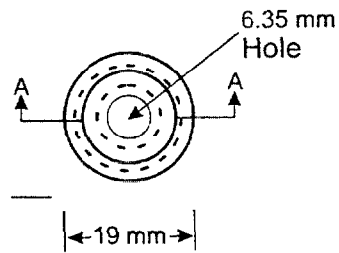
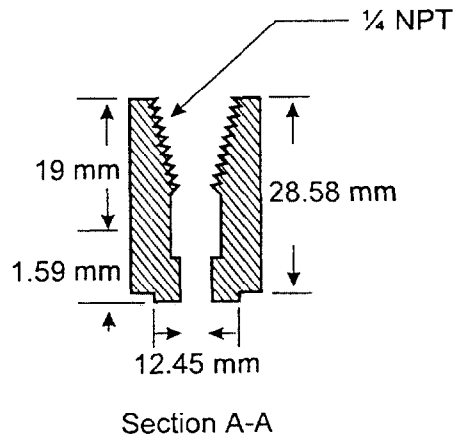

*Note: Use Drilled
Out Swagelok Fitting
SS-200-1-4 or Equivalent
to Lock in Lock (3.175 mm)
Sheathed Therocouple*

Material: Stainless Steel
Quantity: 1

5/16-18 Blind Nut
Part No. 30

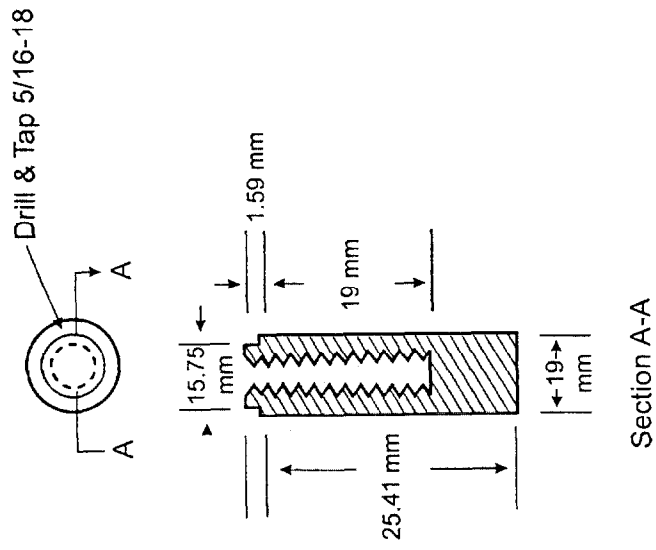

Material: Stainless
Quantity: 6

**Inlet/Drain Water Elbow
Part No. 31**

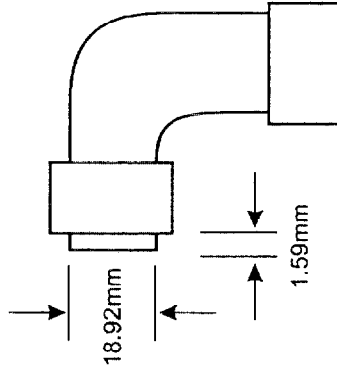

Modify Cajon
Pipe elbow #SS-4-E

Material: Stainless Steel
Quantity: 1

Inlet/Drain Water Diverter Fits in Part No. 31

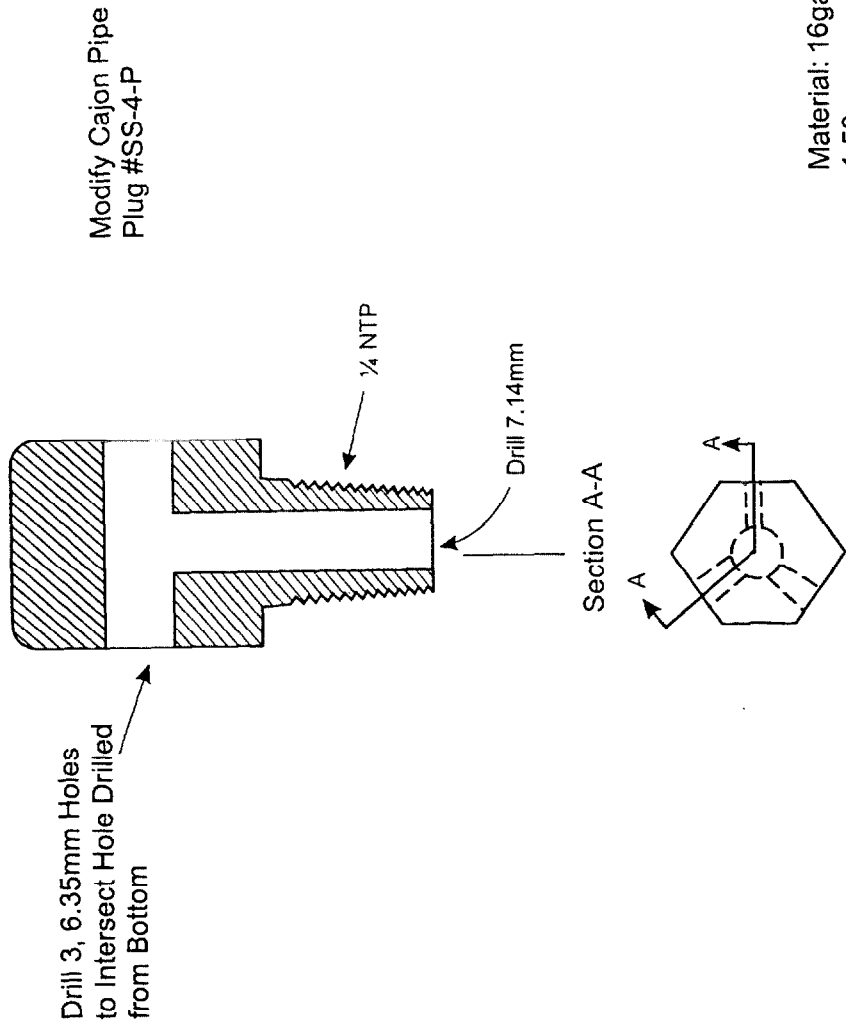

Material: 16ga Stainless Steel
1.59
Quantity: 1

Water Depth Pointer

A40

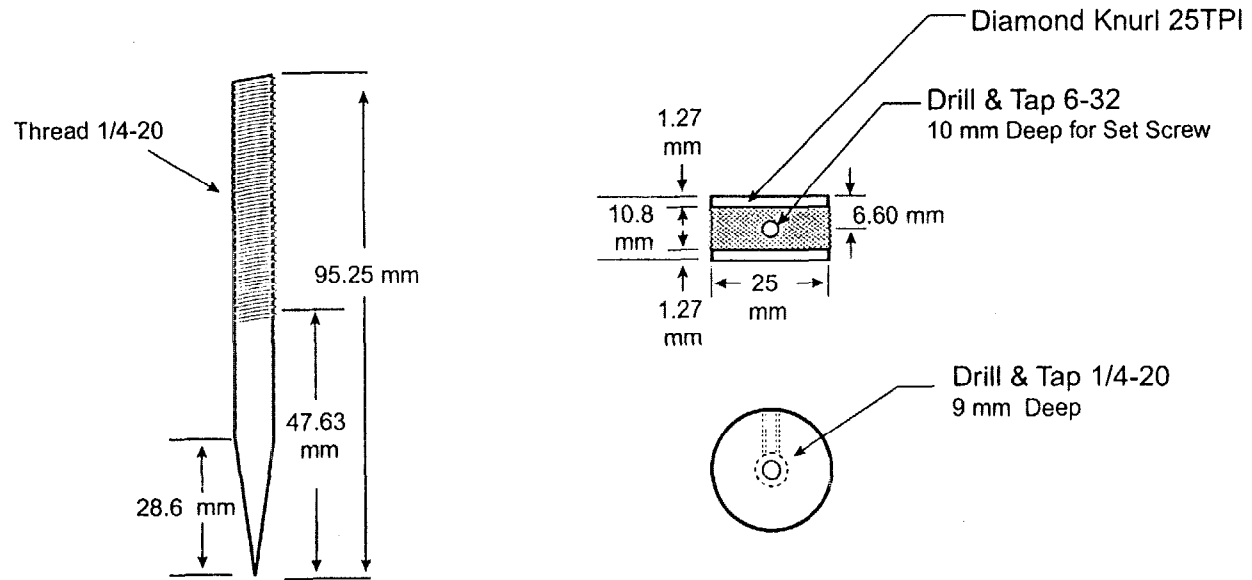

Material: Stainless Steel
Quantity: 1Each

Water Depth Pointer Bracket

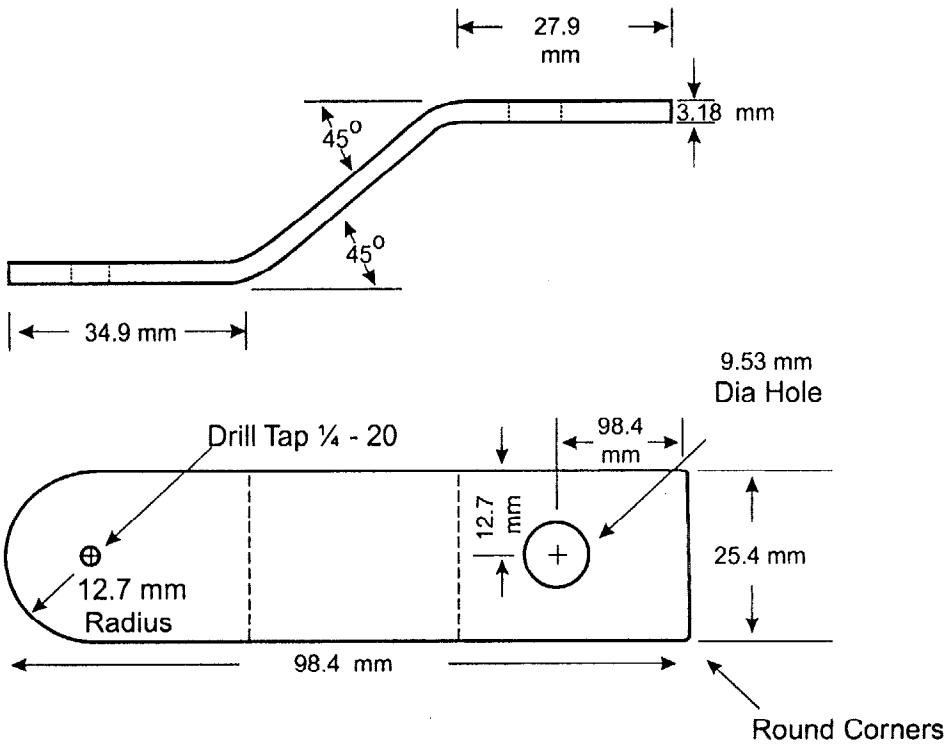

A41

Material: Stainless Steel
Quantity: 1

Pneumatic Circuit

A42

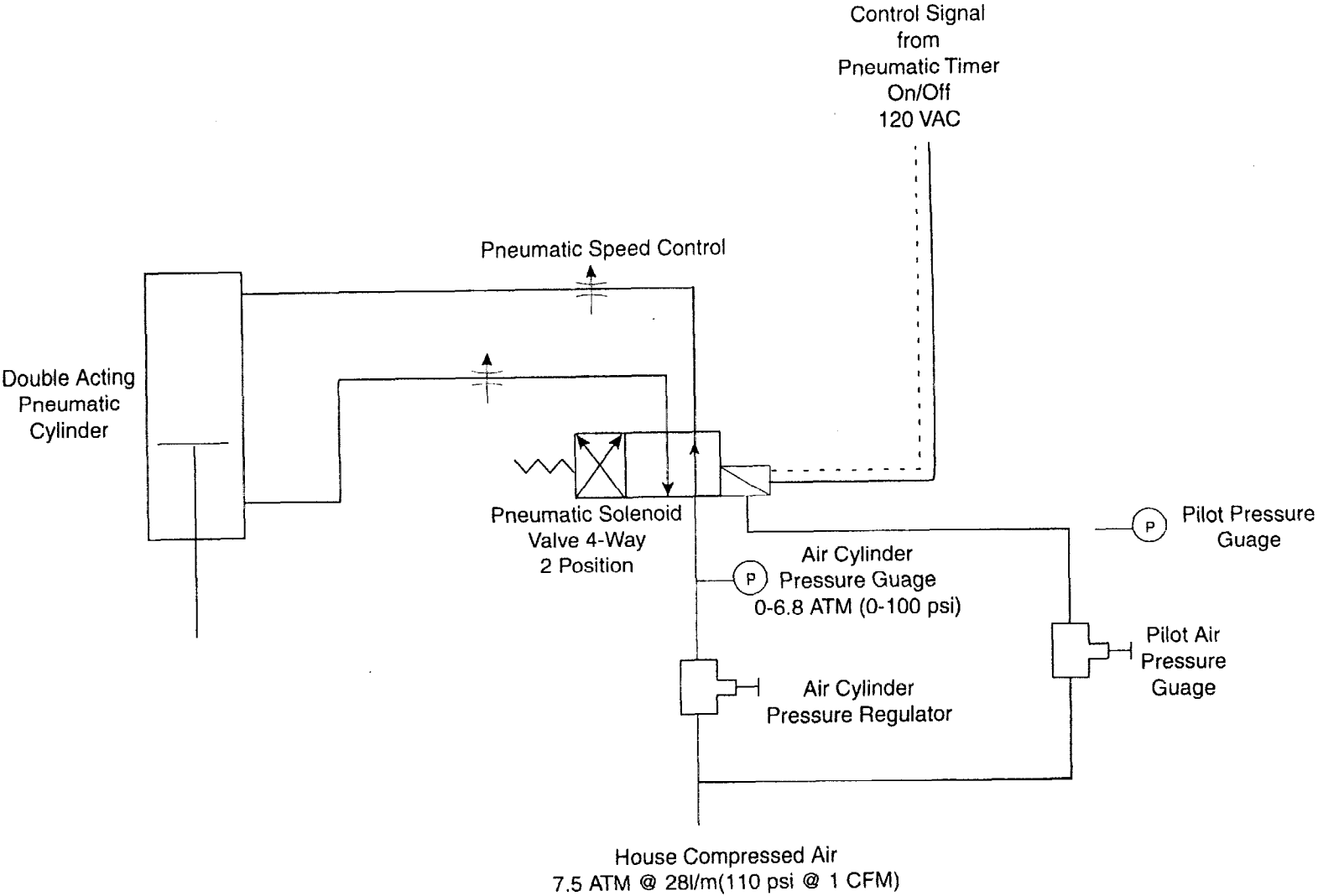

Electrical Circuit Layout

