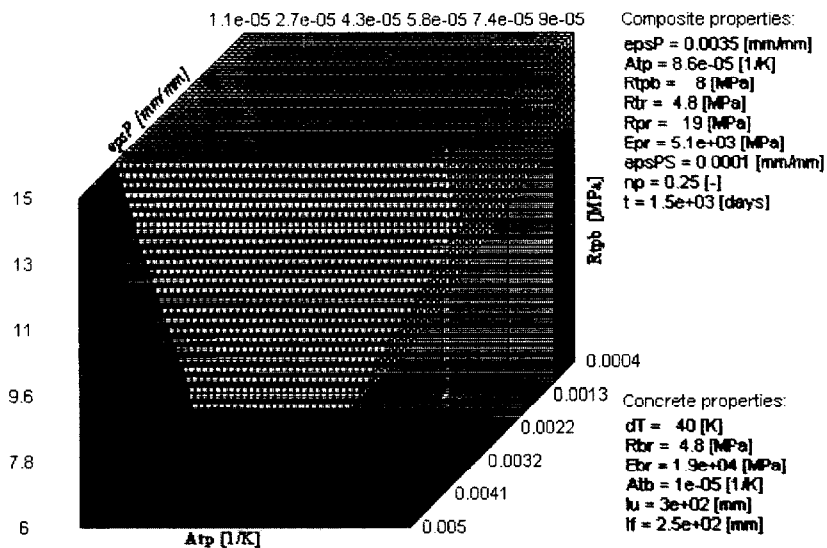


# Polymer Composites for Repairing of Portland Cement Concrete: Compatibility Project

Lech Czarniecki, Andrzej Garbacz,  
Pawel Lukowski  
Warsaw University of Technology  
Warsaw, Poland

James R. Clifton  
Building and Fire Research Laboratory  
Gaithersburg, Maryland



United States Department of Commerce  
 Technology Administration  
 National Institute of Standards and Technology

# Polymer Composites for Repairing of Portland Cement Concrete: Compatibility Project

---

---

Lech Czarnecki  
Andrzej Garbacz  
Pawel Lukowski  
James R. Clifton

November, 1999

Building and Fire Research Laboratory  
National Institute of Standards and Technology  
Gaithersburg, MD 20899



**National Institute of Standards and Technology**  
William M. Daley, *Secretary*  
**Technology Administration**  
Gary R. Bachula, *Acting Under Secretary for Technology*  
**National Institute of Standards and Technology**  
Ray Kammer, *Director*

## ABSTRACT

The impetus for this project has been the continuing deterioration of, and the necessity to repair, a large stock of concrete structures. A two-component system, portland cement concrete (substrate) in contact with a polymer composite (repair), is produced as the result of a repair. The reliability and durability of a repaired concrete structure and its remaining service life depends, to a great degree, on the behavior of the repair material, which is controlled by the compatibility between the two materials making up the repair system. The main scientific objective of this project has been the analysis and prediction of this compatibility using the compatibility space concept, which is defined mathematically, with the aim of understanding the nature of the two-component repair system. The engineering objective has been to develop a useful computational tool for predictions of the behavior and effectiveness of polymer composite-portland cement concrete systems so as to select the proper repair/protective materials for a specific application. The compatibility space can also be analyzed to help predict the properties that will be needed by new materials.

Results of the project are presented in this report, and in the Compatibility Computer System (CCS), whose User's Manual has been published as an appendix to this report. A second appendix contains a list of the 17 publications that were presented at international forums in English and Polish and published in proceedings and journals during the project. The project's results are in general accord with worldwide scientific and engineering activities in repair materials. e.g., US Research Program on Repair, Evaluation, Maintenance and Rehabilitation (REMR), European Standard Activity on products and system for the protection and repair of concrete structures (ENV 1504 – pending) as well as the periodic meetings of the International Colloquium on Materials Science and Restoration.

## DISCLAIMER

Certain commercial equipment is identified in this report in order to adequately specify the experimental procedure. In no case does such identification imply recommendation or endorsement by the National Institute of Standards and Technology, nor does it imply that the equipment used is necessarily the best available for the purpose

## **1. INTRODUCTION**

## **2. BASIC APPROACH**

- 2.1 Serviceability**
- 2.2 Definition of material control parameters**
- 2.3 Approach to the compatibility concept**
- 2.4 Assumptions of compatibility models**

## **3. COMPATIBILITY SPACE SEARCH METHOD**

- 3.1 Main idea**
- 3.2 General structure of Compatibility computer program**
- 3.3 Examples of compatibility space for selected models of PC-CC system**

## **4. VERIFICATION TESTS OF THE COMPATIBILITY OF VARIOUS POLYMER COMPOSITE - PORTLAND CEMENT CONCRETE SYSTEMS**

- 4.1 Verification approach**
- 4.2 Adhesion test methods**
  - 4.2.1 Pull off test**
  - 4.2.2 Dynamic loading test**
  - 4.2.3 Slant shear test**
  - 4.2.4 Direct shear test**
  - 4.2.5 Thermal compatibility tests**
  - 4.2.6 Four-point bending test**
- 4.3 Determination of adhesion between concrete substrate and repair composites**
  - 4.3.1 System characterization – preliminary tests**
  - 4.3.2 Laboratory verification of structural surfacing predictions**
  - 4.3.3 Laboratory verification of coatings on portland cement concrete**
  - 4.3.4 Laboratory verification of crack injection repair situation and materials**
  - 4.3.5 On site verification of repair material for surface protection of reinforced concrete tank**

## **5. COMPATIBILITY COMPUTER PROGRAM POSSIBILITIES**

## **6. SUMMARY AND CONCLUSIONS**

## **7. REFERENCES**

**APPENDIX 1: List of publications involved with the project**

**APPENDIX 2: User's Guide to Compatibility program**

## **1. INTRODUCTION**

New developments in civil engineering and growing industrial activities create a continual demand for building materials that must satisfy increasingly stringent requirements [1]. Ordinary portland cement concrete is a ready-to-use, widely available building material, but its low durability under many service conditions seems to be the price paid for its universality [2]. Polymer composites appear to be useful protective and repair materials. They could be a valuable means to enhance the durability of portland cement concrete exposed to the action of aggressive factors. The repair and anti-corrosion protection of a building structure are two of the most important applications of polymer composites [3-5]. They can be considered as high performance repair materials for portland cement concrete structures, usually used under severe service conditions [6]. Surface repair, partial depth repair, full depth or structural repair, and strengthening are typical examples of application. A two component system - portland cement concrete (substrate) in contact with a polymer composite (repair) - is produced in a typical repair situation. Lack of understanding of the polymer composite (PC) – portland cement concrete (CC) interaction is frequently the source of failure in practice. The compatibility of PC – CC systems is the main problem that was considered in this study [7-8].

The scientific aim of the study was to improve understanding of the PC-CC system, and in particular, the compatibility between the two sub-units. From the engineering point of view, the aim was to produce a useful tool for predicting the behavior of the two-component PC-CC system and its durability, as well as for selection of the proper repair/protective material for a specific application.

It should be noted at this point that the methodology used, and the software tool developed using this methodology, in no way precludes the use of concrete substrates other than those based on portland cement concrete. So we could use the term “cement concrete substrate” throughout this report, rather than “portland cement concrete substrate.” However, since the work described in this report was confined to portland cement concrete substrates, we use the latter terminology. In addition, in the methodology used, the repair system was assumed to be a two-component system – repair material and substrate material. Repair is often considered to be a three-phase system – substrate, repair material, and a transition zone between them. By using interlayer adhesion or bond strength as a material control parameter (see Sec. 2.2), this transition zone is implicitly included in what is nominally only a two-phase repair system.

## **2. BASIC APPROACH**

### **2.1 Serviceability**

Material serviceability in construction must be considered in light of the various requirements that are defined by environmental service conditions. These requirements determine the mathematical space of loads, including chemical, mechanical, and physical (mainly thermal) loads. The interactions among the kinds of material properties required to sustain given loads define the subspace of material serviceability, as is shown schematically in Fig.1. Region I is the region where the material used can sustain the system loads, producing good serviceability.

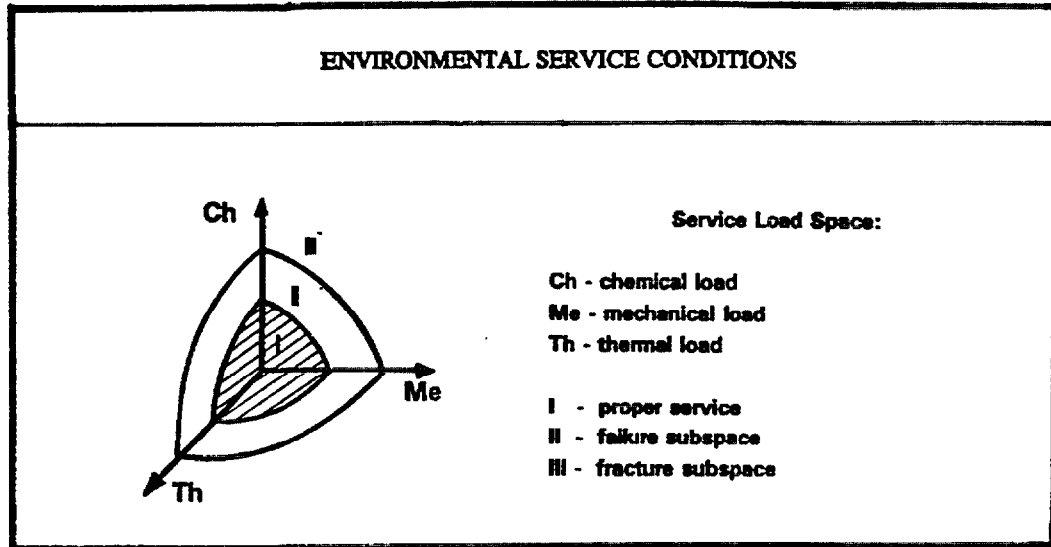


Figure 1. Environmental service conditions.

If the loads increase, as shown in Fig. 1, the failure (II) and fracture (III) sub-spaces are then entered, reducing the service life and ultimately leading to failure. Repairs result in a two component system: polymer composites – portland cement concrete. In this case, the situation is even more complicated due to the compatibility problem. The two components must work together to supply the load resistance that formerly only the concrete substrate provided. In engineering practice, significant variability of the behavior of such a system is usually observed. Sometimes a repair is reliable and durable. In other cases, failures occur after different periods of service time. Different failure mechanisms possible for such a two-component system are shown schematically in Fig.2. This problem of compatibility of repair materials with a portland cement concrete substrate has been analyzed in this project, and the results summarized in this report.

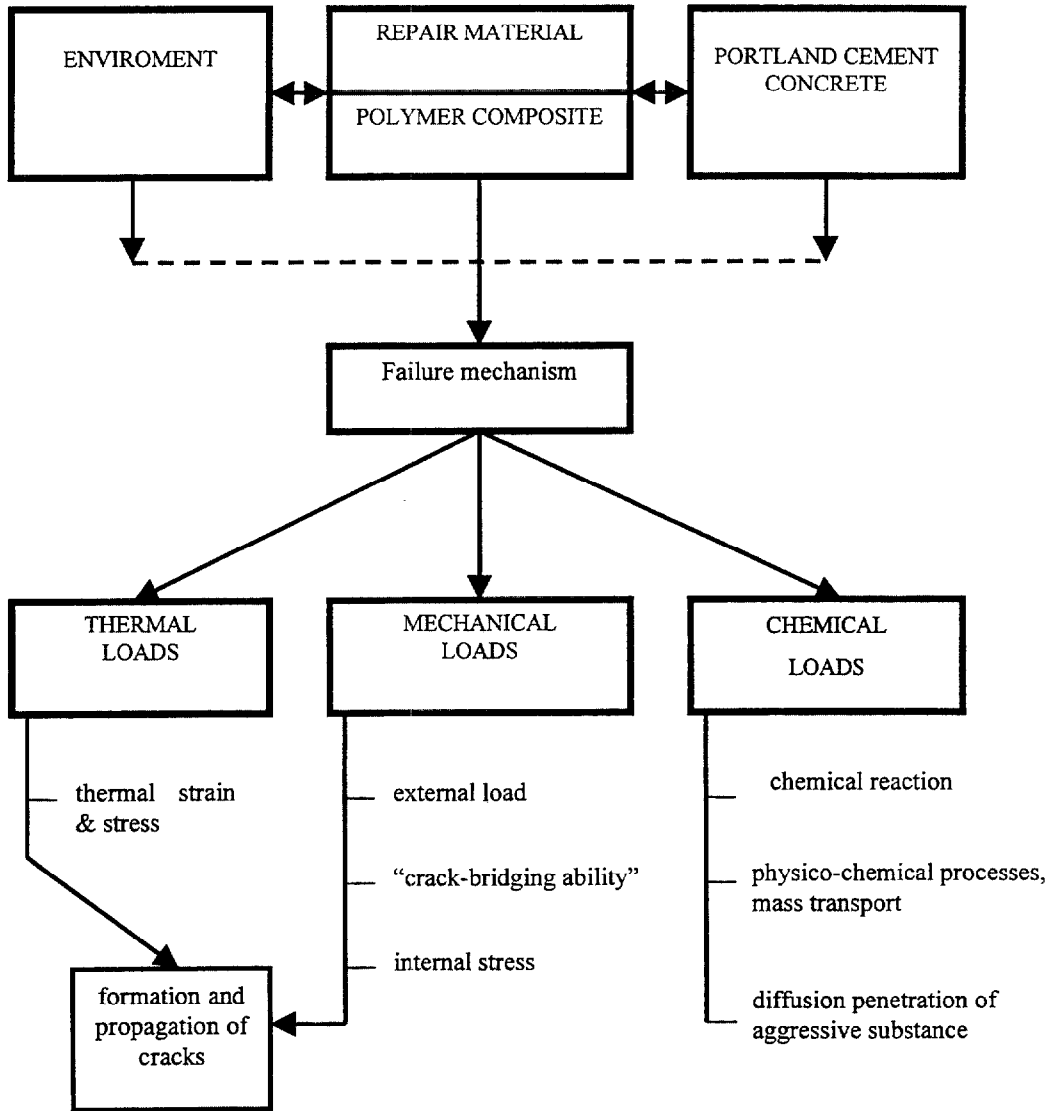


Figure 2. Scheme of possible deterioration mechanisms for a two-component repair material-substrate system.

## 2.2 Definition of material control parameters

Concrete substrates differ in age and quality. Their condition before repair commences can vary from only having a small amount of deterioration, all the way to severely deteriorated concrete. Concrete substrates are also exposed to various temperatures, relative humidities, aggressive chemical environments, and mechanical loads. There are two basic problems involved with the usability of polymer composite repair materials and the durability of the system as a whole [9]: (1) proper formulation of the polymer concrete to obtain a material with the properties that meet requirements, which is a material design and optimization problem [10,11], and (2) the compatibility of the system subunits, which is a problem of materials selection and evaluation of the two-component system behavior [12]. Compatibility is an intuitive term, whose exact definition in terms of material serviceability is given in Sec. 2.3. For now, it can be thought of as the interaction of the material properties of the two component repair system during service.

Research into what is the proper formulation of the polymer composite repair material in order to achieve given material properties has been carried out. An optimization program is available for aiding this endeavor [10,11]. However, the compatibility of PC - CC systems is still a significant and difficult problem [13,14], as has been stressed by other authors [15,16]. In all this work, the concrete substrate is assumed to be given, and the proper repair material must then be selected for the given substrate and service loads. This, of course, is the usual repair scenario, with repairs being made only (hopefully) after the concrete substrate has been in place for several years.

On the basis of literature data [17] and recent research [18,19], the technical properties of the polymer composite repair material and the concrete substrate that influence the PC - CC system have been selected and their probable range of values have been defined. These are called the *material control parameters*. The following properties, listed in Table 1, have been considered as the material control parameters. These include: mechanical parameters such as bond strength, cracking resistance, interlayer adhesion, and ultimate strength in glue joints, thermal parameters such as setting shrinkage, thermal compatibility, thermal resistance including shock resistance, and chemical resistance controlled by the mass transport process.

This set of requirements can be expanded. An additional parameter might be, for example, the freeze-thaw resistance. An inequality characterizing the freeze/thaw resistance might be expressed in terms of a balance between the water permeability and the tensile strength of the given material (see Sec. 2.4).



Table 1. Material control parameters for the compatibility of the polymer composite – portland cement concrete (PC - CC) system

MATERIAL CONTROL PARAMETERS	
Polymer composite	Portland cement concrete
$R_r^P$ - tensile strength, MPa $E_t^P$ - tensile elasticity modulus, MPa $E_c^P$ - compressive elasticity modulus, MPa $\alpha_t^P$ - linear expansion coefficient, $K^{-1}$ $\lambda^P$ - thermal conductivity, W/ mK $\nu^P$ - Poisson's coefficient $\varepsilon^P$ - ultimate tensile strain, % $\varepsilon_s^P$ - linear shrinkage, % $D$ - diffusion coefficient, $cm^2s^{-1}$ $R^{P/P}$ - PC-PC interface shear strength, MPa $h_p$ - thickness, m $l_r$ - length of substrate crack covering layer, mm $t$ - time of penetration, s	$R_c^B$ - compressive strength, MPa $R_r^B$ - tensile strength, MPa $E^B$ - tensile elasticity modulus, MPa $\alpha_T^B$ - linear expansion coefficient, $K^{-1}$ $\lambda^B$ - thermal conductivity, W/ mK $h_p$ - thickness, m $a_r$ - crack width, mm $\Delta a_r$ - maximum possible crack width change, mm
$R^{P/B}$ - interface shear strength, MPa $R_{pr}^{P/B}$ * - interface tensile strength, MPa $\Delta T$ –temperature gradient during service, K	

\* For injection and glue joints

### 2.3 Approach to the compatibility concept

The basis for repair material selection has been changing over time. In the past, “repair of materials only by similar materials” was the rule used. It should be stressed that “similarity” meant only material similarity, i.e., only cementitious materials should be used for repairing cementitious substrates. D. Plum in 1990 stated, as well as have other authors, that this concept is not logical [20]. At present, the repair material selection rule has been to have similarity of the *technical* properties. However, the problem of selecting a proper repair material still remains a difficult one. There is a great need to develop a computer-based tool, similar to that for polymer concrete optimization [10,11], that can be used to predict the behavior of the complete repair system and to select the proper polymer composite repair material for the given application.

The boom in new building products since the beginning of the 1990’s has spawned many new polymer-mineral composites and, as a consequence, the situation of “*embarrasse de richesse*.” Common questions that often arise concerning these repair materials include “how to select ?” [21], “according to which criteria ?” [22], and, not surprisingly, “why do they fail ?” [23]. In 1997 the European pre-standard ENV 1504-9: 1997 “Products and systems for the protection and repair of concrete structures” formulated the general principles of the problem. The standard defines a matrix of 90 material properties multiplied by 26 repair methods. This demonstrates how complicated the problem can be.

In 1991 L. Czarnecki et al. [24], and in 1992 P. Emmons et al. [25] presented some compatibility problems in choosing repair materials. Following the discussion at the International Colloquium in Esslingen, entitled “Material Science and Restoration,” the precise meaning of the term *compatibility* has become more precise. *Compatibility* is defined as selection of the elements of the repaired system, according to chemical and physical properties, to ensure that the acceptable mechanical stresses (in some cases also the deformations) are not exceeded in any part of the system during the predicted service life under the prevailing use conditions. We note that mechanical stresses are what damage materials, but these stresses can come from loads other than mechanical ones. This definition has been basic to the present study.

### 2.4 Assumptions of compatibility models

If a repair material and a portland cement concrete substrate work well together, performing the function intended for an acceptable service life, we say that the materials have good compatibility or are compatible. The requirements for good compatibility between polymer composite repair materials and a portland cement concrete substrate can be formulated using mathematical inequalities, where the variables are the material control parameters. The important material control parameters are listed in Table 1. When the material control parameters are selected, their ranges must also be defined for a given repair system. Materials that satisfy these inequalities should result in a repair that has a proper equilibrium among reliability, durability and economy.

These mathematical inequalities have been formulated using assumptions that were made to keep the compatibility model sufficiently accurate yet simple enough to use easily. These simplifying assumptions include: validity of Hooke's law, lack of synergistic effects of various loads (loads acts in a linearly additive fashion), and service temperature always below the glass transition temperature of the polymers used.

The mathematical inequalities that define the compatibility of the polymer composite - portland cement concrete system are listed in Table 2. They define the compatibility requirements for: crack resistance (Eq.1), crack-bridging ability (Eq.2a – already-cracked substrate and Eq.2b – cracking may occur in uncracked substrate), adhesion to concrete substrate in shear (Eq.3a) and tensile (Eq.3b) conditions, interlayer adhesion of repair material (Eq.4), thermal compatibility (Eq.5), stress compatibility (Eq.6), resistance to thermal shock (Eq.7), shrinkage stress resistance (Eq.8a-8c), and diffusion resistance of the coating (Eq.9).

An N-dimensional mathematical space is defined by the N different material control parameters for the repair system and their allowable ranges. Within this space, if there is a region in which the inequalities are satisfied, this region is called the “compatibility space” that determines the requirements for compatibility in a PC-CC system. This sub-space must be calculated. If N is bigger than 1 or 2, a computer program must be used because of the complicated nature of the problem. For example, a 12-dimensional (N=12) compatibility space must be evaluated for anti-corrosion protection by a polymer composite coating. This approach is flexible, and can be applied to many different types of materials. How to determine the compatibility space is discussed in the next section (Sec. 3.1). Once a compatibility space is determined, its predictions can be compared to experimental data, and the predictability of the model analyzed. Appropriate validation will provide a technical basis for the selection of polymer repair materials, which should result in durable repairs.

Table 2. Mathematical inequalities that determine the compatibility of the PC-CC system

No	Requirements of compatibility	Crack injection	Structural surfacing	Coatings
		Model I	Model II	Model III
1	$\varepsilon_{pr} \cdot l_f \geq \Delta a$	+ 1)	+ 2) for $l_u \geq l_f$	+
2a	$\frac{R_{pr} \cdot h_p}{R_{br}} \cdot \varepsilon_{pr} (1 + \varepsilon_{pr}) \geq \Delta a_r$	-	+ 2)	+ 2)
2b	$\frac{R_{pr} \cdot h_p}{R_{br}} \cdot \varepsilon_{pr} (1 + \varepsilon_{pr}) \geq a_r + \Delta a_r$	-	+ 3)	+ 3)
3a	$R_{\tau}^{p/b} \geq R_{br}$	-	+	+
3b	$R_{pr}^{p/b} \geq R_{br}$	+	+	-
4	$R_{\tau}^{pi/pi+1} \geq R_{br}$	-	+	+
5	$R_{\tau}^{p/b3} > \frac{(\alpha_{ip} - \alpha_{ib}) E_{pr} \cdot E_{br}}{E_{pr} + E_{br}} \cdot \Delta T$	+	+	+
6	$R_{\tau}^{p/b} \geq \frac{\left( \varepsilon_{pr} - \frac{R_{br}}{E_{br}} \right)}{E_{pr} + E_{br}} E_{pr} \cdot E_{br}$	+ 4)	+	+
7	$\frac{\lambda_b}{\lambda_p} < \frac{E_{br} \cdot \alpha_{ib}}{B}$ $B = \frac{(\alpha_{ip} - \alpha_{ib})}{E_{pr} + E_{br}} E_{pr} \cdot E_{br}$	-	-	+
8a	$R_{pr} \geq \frac{0,3 \cdot E_p \cdot \varepsilon_s}{(1 - \nu_p)}$	+	+	+
8b	$R_{\tau}^{p/b3} \geq \frac{0,3 \cdot E_p \cdot \varepsilon_s}{(1 - \nu_p)}$	+	+	+
8c	$R_{\tau}^{pi/pi+1} \geq \frac{0,3 \cdot E_p \cdot \varepsilon_s}{(1 - \nu_p)}$	-	+	+
9	$h_p \geq \pi \sqrt{D \cdot t}$	-	-	+

+ condition that determines the compatibility of polymer composite with cement concrete,

- the condition does not occur,

1) - in this case:  $l_f = a_r$ , 2) - in regard to the cracked concrete surface, 3) - in regard to the non - cracked concrete surface, 4) - in case of cracks injection  $R_{pr}^{p/b}$  is employed.

### **3. COMPATIBILITY SPACE SEARCH METHOD FOR POLYMER COMPOSITES AND PORTLAND CEMENT CONCRETE**

#### **3.1 Main idea of the project**

The material control parameters and controlling the PC – CC system have been defined in Sec. 2.2 and listed in Table 1. The compatibility of the polymer composite – portland cement concrete system has been characterized by mathematical inequalities involving these parameters, as listed in Table 2. The models developed in this work are then based on calculating the compatibility space of the two kinds of materials, which is the region in the N-dimensional material control parameter space in which the inequalities of Table 2 are satisfied.

Determining this compatibility space involves searching for this space by sequential substitution of suitable material property values, chosen from the range of values that occur in practice and satisfy the allowable ranges (chosen for each problem). Although many kinds of repair can be considered, each with its own parameter and compatibility space, we have only considered three types of models for three kinds of repair systems. These three choices are shown schematically in Fig.3 and are: model I – crack injection, model II – structural surfacing, and model III – coating application. Figure 3 clearly shows the difference between structural surfacing and a simple coating application. The actual material control parameters and their allowable ranges used for these models are shown in Table 3. The reader is reminded that material control parameters are chosen for both the polymer concrete repair material and the portland cement concrete substrate that is being repaired.

For each repair case, the following procedure, shown schematically in Fig. 4, was carried out. First, the important material control parameters were chosen from the list given in Table 1. Second, the inequalities were chosen that apply to the problem. These were chosen according to the type of concrete failure anticipated and the type of repair that was made. The compatibility space was then determined with our Compatibility computer program (see User's Guide in Appendix 2), and the results were experimentally verified. The validated Compatibility program was then used to calculate new compatibility subspaces defined by various properties of the concrete substrate and the repair materials, and according to various application options (variable thickness of coating on the concrete, range of temperature changes, etc.). Thus new repair options can be studied by virtual analysis, within the range of the three cases investigated, using the Compatibility computer program.

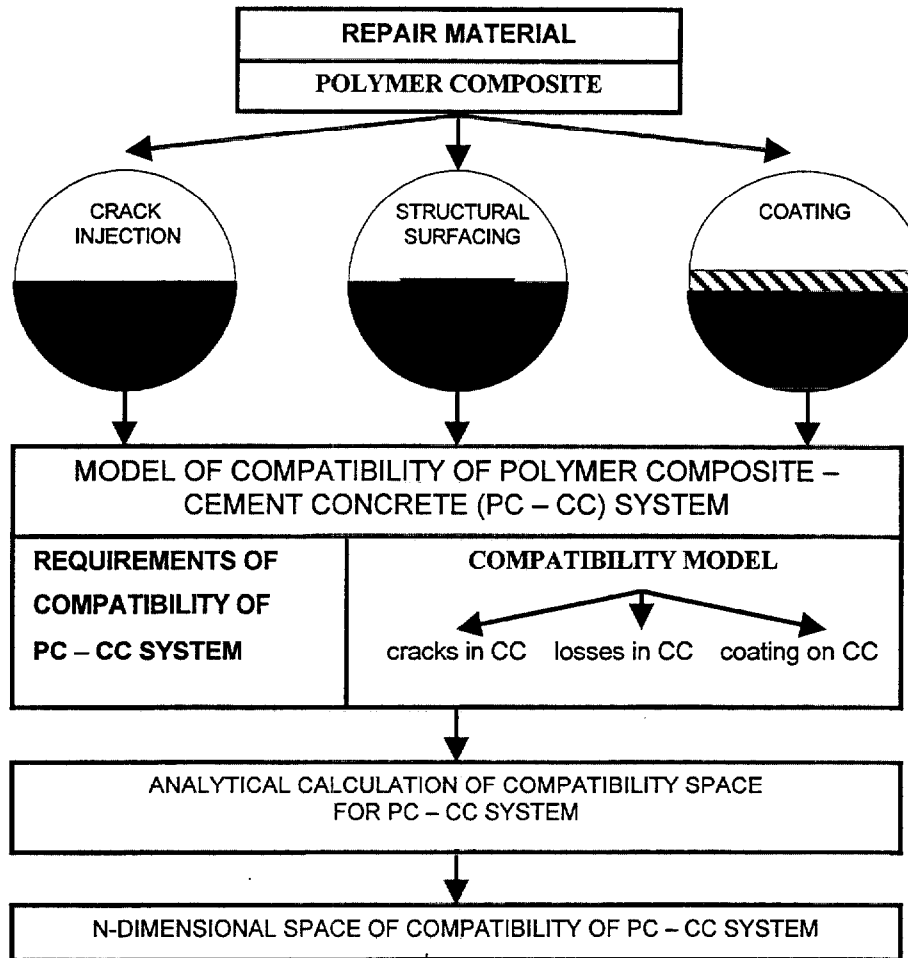


Figure 3. Schematically showing the three kinds of repair situations/models considered in this work, along with an outline of the approach to the basic problem.

Table 3. Material control parameters – boundary ranges (see Table 1 for parameter definitions)

No.	Symbol, units	Application range		
		crack injection	structural surfacing	Coatings
1	$R_{\tau}^{P/b}$ , MPa	4.50 – 6.00	4.50 – 6.00	4.50 – 6.00
2	$R_{\tau}^{P/P}$ , MPa	-	4.50 – 15.00	4.50 – 15.00
3	$R^P$ , MPa	2.60 – 60.00	5.00 – 40.00	8.00 – 60.00
4	$E_{Pr}$ , Gpa	0.20 – 8.00	4.00 – 26.00	0.20 – 26.00
5	$\varepsilon_p - 10^{-4}$	0.35 – 2.80	0.04 – 1.70	0.10 – 40.00
6	$\varepsilon_{ps} - 10^{-3}$	0.10 – 18.00	0.05 – 3.00	0.05 – 13.00
7	$\lambda_p$	0.12 – 0.35	0.07 – 0.45	0.12 – 0.45
8	$D - 10^{-9}$	-	-	0.50 – 7.00
9	$t$ , years	-	-	0 – 10
10	$h_p - 10^{-2}$	$\leq 0.30$	0.30 – 10.00	0.20 – 2.00
11	$\alpha_T^P - 10^{-5} K^{-1}$	2.00 – 12.00	1.00 – 9.00	1.00 – 12.00
12	$a_{\tau}$	1 – 3	1 – 3	1 – 7

## POLYMER COMPOSITE AS A REPAIR MATERIAL – COMPATIBILITY PROBLEM

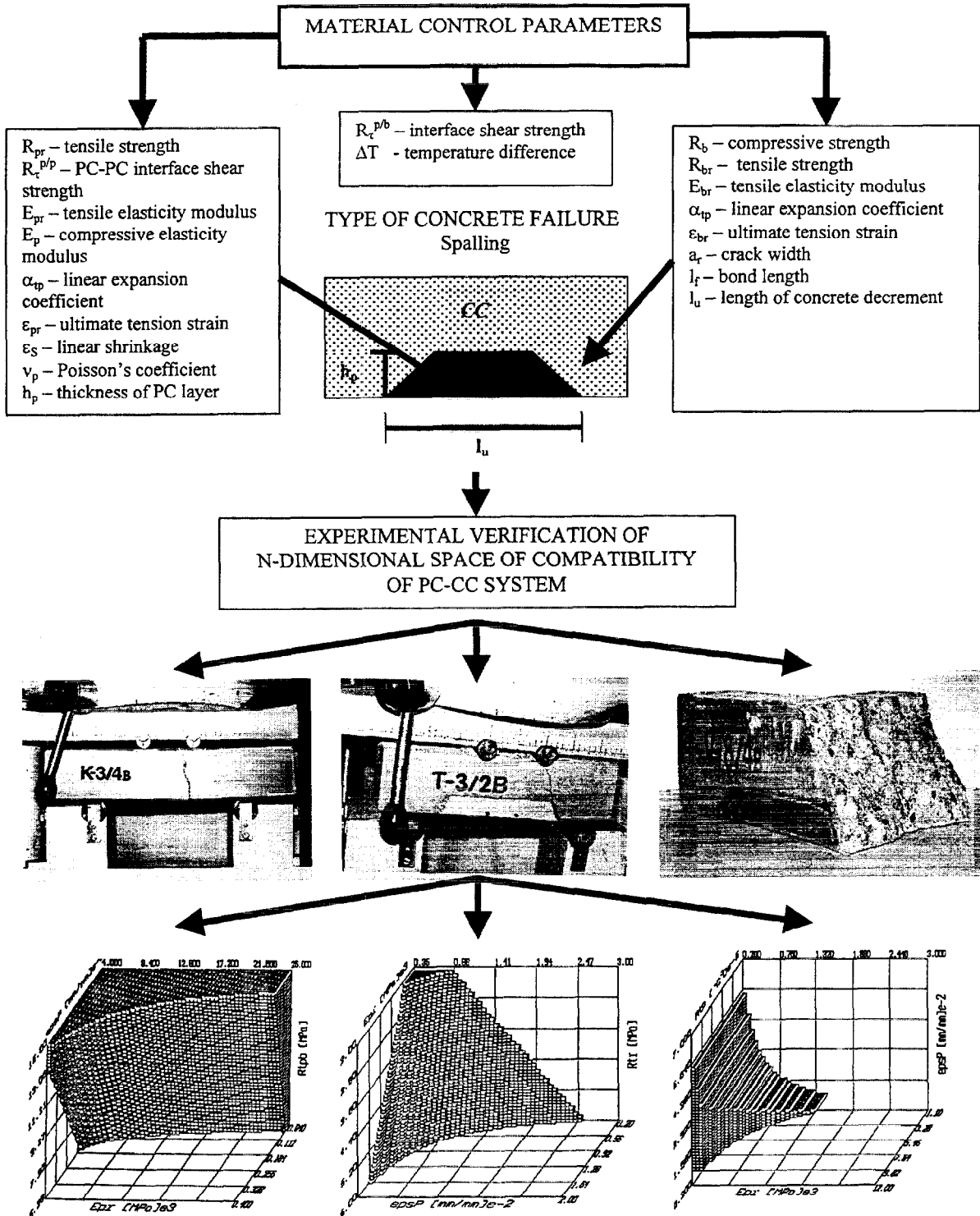


Figure 4: Schematic outline of work of the repair material compatibility project



### 3.2 General structure of Compatibility computer program

The three repair models studied are mathematically described by a set of suitable linear and non-linear inequalities, taken from those given in Table 2, which are the requirements of compatibility. The material control properties of the polymer composites and the portland cement concrete substrate are the variables of the inequalities. Determination of the compatibility space is done by solving the set of inequalities by successively ascribing all possible values ( $x_1, x_2, \dots, x_n$ ) of the material control properties. The solution of the set of inequalities defines the N-dimensional compatibility space. This solution is a complicated and time-consuming process for more than 1 or 2 variables. The Compatibility computer program has been developed for the determination of the compatibility space. The program consists of three calculation procedures: BASIS, VERIF, EXPAND, and two graphic procedures: GRAPH-2D and GRAPH-3D, as described briefly below (see Appendix 2 for the complete User's Guide).

**BASIS:** analysis of compatibility space at boundary conditions (or nodes, defined in Fig. 5), which is where the minimum and maximum values of the materials control properties occur.

**VERIF:** supplementary procedure to the procedure BASIS, and used in the case when the nodes of the space determined in procedure BASIS are not solutions of the set of inequalities. The procedure is used to check if points between the nodes of the space determined by the BASIS procedure satisfy the inequalities (see Fig. 5).

**EXPAND:** the most important program procedure, which is used for determining the N-dimensional parallelipipeds belonging to the common parts of the solution of the set of inequalities. These N-dimensional regions are obtained by building up the space defined by the nodes determined in the BASIS or VERIF procedures.

**GRAPH-2D and GRAPH-3D:** procedures used for graphical presentation of two and three dimensional subspaces of the compatibility space.

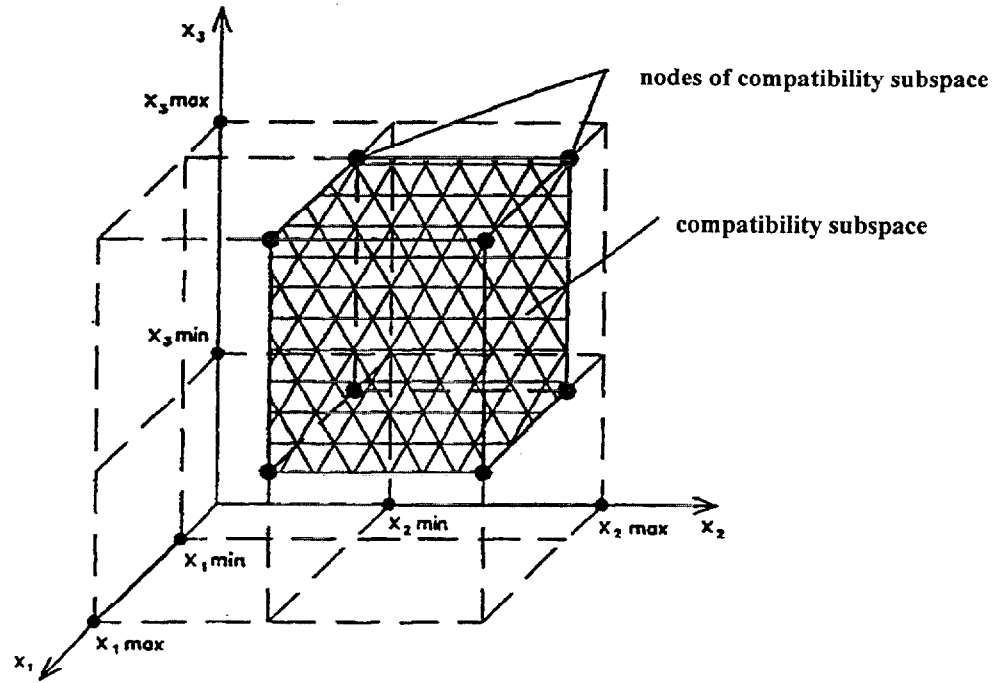
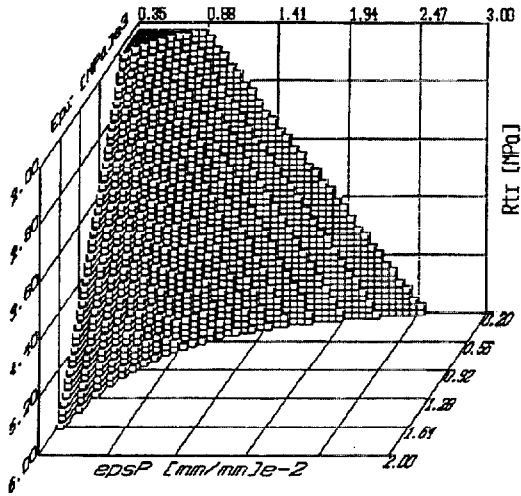


Figure 5. The solution space formed by three variables:  $x_1$ ,  $x_2$ ,  $x_3$

### 3.3 Examples of compatibility space for the selected models of PC-CC system

It is important for the reader to get a “feel” for what compatibility spaces look like, and how their shape and size are affected by changes in the material control parameters. To facilitate this intuition, some examples of compatibility spaces for the three basic PC-CC system models considered are presented in Figs. 6-8. For each figure, parts a) and b) show how the compatibility space (or subspace, terms used interchangeably) can change when one material control parameter is varied. The factors used were repair type (injection, structural surfacing, anti-corrosion coating), the quality of the concrete substrate, the permissible width of cracks in the coating, and changes of the temperature during service.

a)



b)

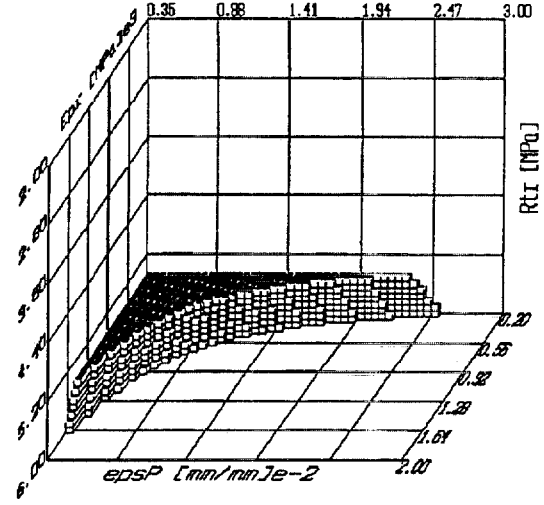


Figure 6. Example of a 3-D compatibility subspace for a polymer composite and portland cement concrete of B25 class (a) and B50 class (b) in the case of crack injection for a service temperature change of  $\Delta T = 20$  K, where Bn means a compressive strength of at least n MPa.

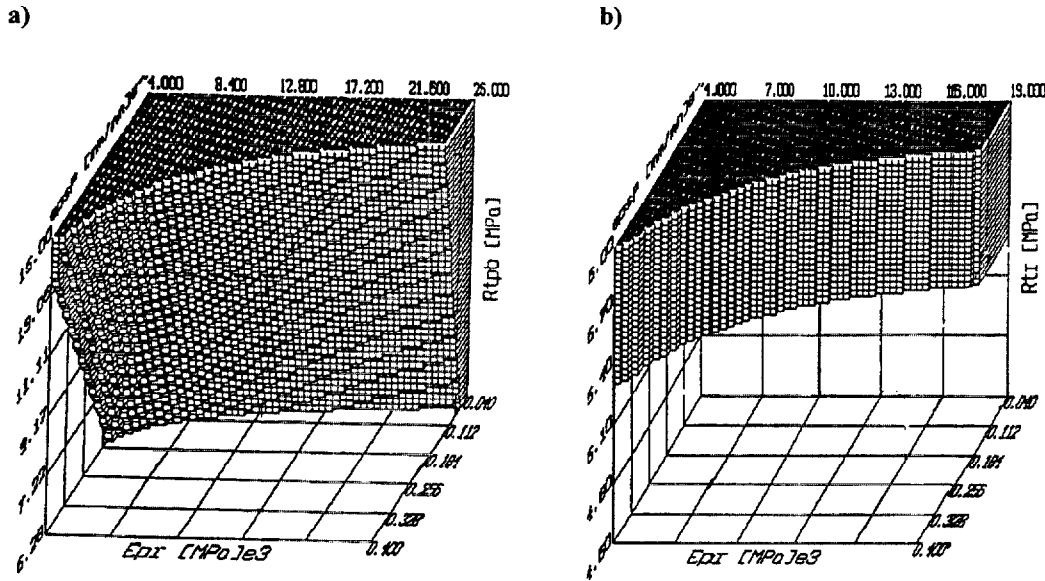


Figure 7. Example of a 3-D compatibility subspace for a polymer composite and portland cement concrete in the case of structural surface repair of the non-cracked substrate for service temperature changes  $\Delta T$ , of : (a) 20 K and (b) 40 K

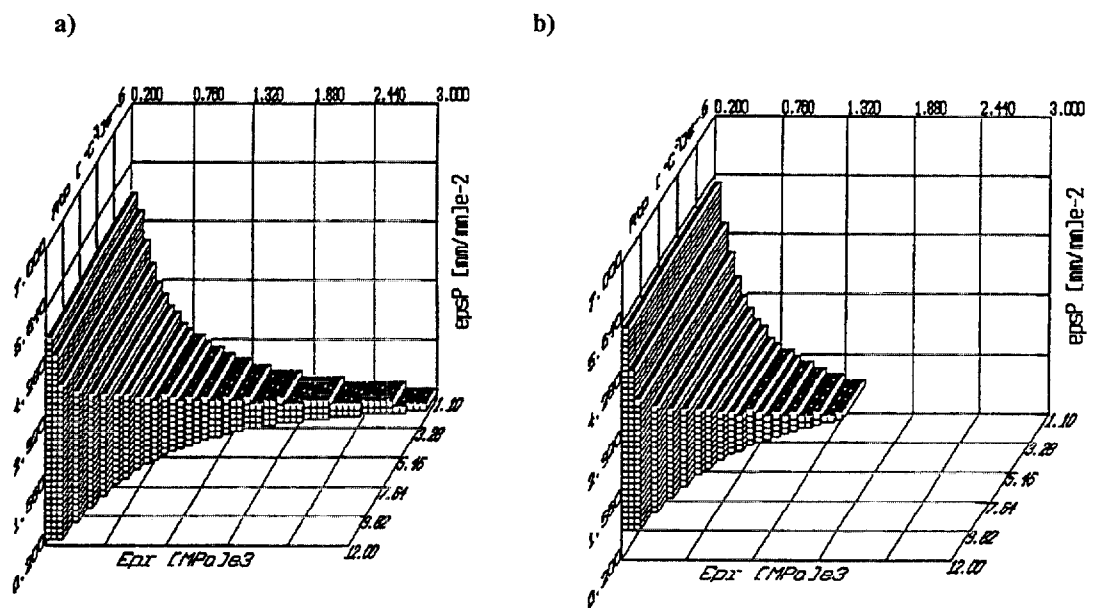


Figure 8. Example of a 3-D compatibility subspace for a polymer composite and portland cement concrete in the case of an anti-corrosion coating protection of the concrete substrate, where crack widths of: (a) 0.1 mm and (b) 0.2 mm were considered acceptable, for a service temperature change of  $\Delta T = 20K$ .

## **4. VERIFICATION TESTS OF THE COMPATIBILITY OF VARIOUS POLYMER COMPOSITE – PORTLAND CEMENT CONCRETE SYSTEMS**

### **4.1 Verification approach**

The compatibility spaces obtained by computer calculation must be verified by experiment to prove the adequacy of the compatibility models for the PC-CC system. One way to carry out this verification process is by testing to determine the adhesion between polymer composites and the portland cement concrete substrate. Adhesion testing is used because it is the most common failure mode for polymer composite repairs of portland cement concrete substrates. The methods of testing recommended by RILEM Technical Committee TC 52 - RAC and TC 113 - CPT were used to determine the adhesion between the portland cement concrete substrate and selected types of polymer composite repair materials. Some other test methods recommended by RILEM TC 113 – CPT for PC-CC systems were also used. These test methods are described in more detail in the next section. Cases of compatibility and incompatibility have been used to validate the Compatibility program. Section 4.2 describes the various test methods used, while Sec. 4.3 describes the systematic verification of the compatibility models for the three kinds of repairs considered.

### **4.2 Adhesion test methods**

#### **4.2.1 Pull off test**

This method tests the adhesion of coatings with thickness  $t_0$  applied on dry or wet concrete. Adhesion is measured in terms of the tensile stress required to remove or cause failure of a cylindrical section of the surface coating that has been isolated from the surrounding coating. The load should be applied at a stress rate of  $0.1 \text{ N/mm}^2 \text{ s}^{-1}$  until failure occurs. The test configuration is shown schematically in Fig. 9. The maximum tensile stress and failure mode were determined. A minimum of five test spots were prepared on one or more concrete substrate specimens, as is shown in Fig.10.

The possible failure modes are shown in Fig.11. These failure modes are: A = cohesive failure within the concrete substrate, A/B = adhesion failure between the coating and concrete substrate, and B = cohesive failure within the coating. In the case of the A/B or combined failure mode, the share of each mode of failure shall be estimated as 25 %, 50 % or 75 %. If failure occurs at the interface between the piston and the coating, the test should be run again, as this result is not an acceptable outcome.

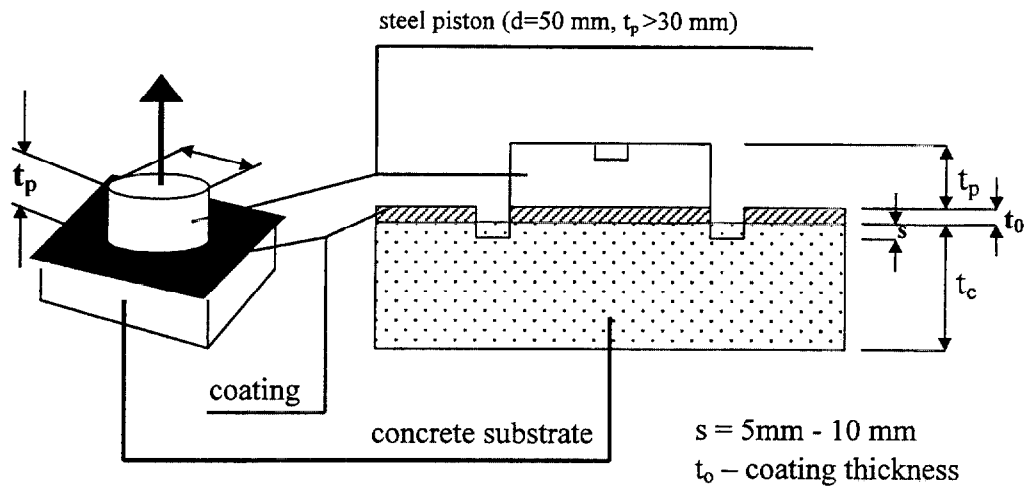


Figure 9. Test configuration;  $t_{\min} = 100\text{ mm}$ ,  $f_{c\min} = 50\text{ MPa}$ ; aggregate grain max diameter = 16 mm, other dimensions in mm.

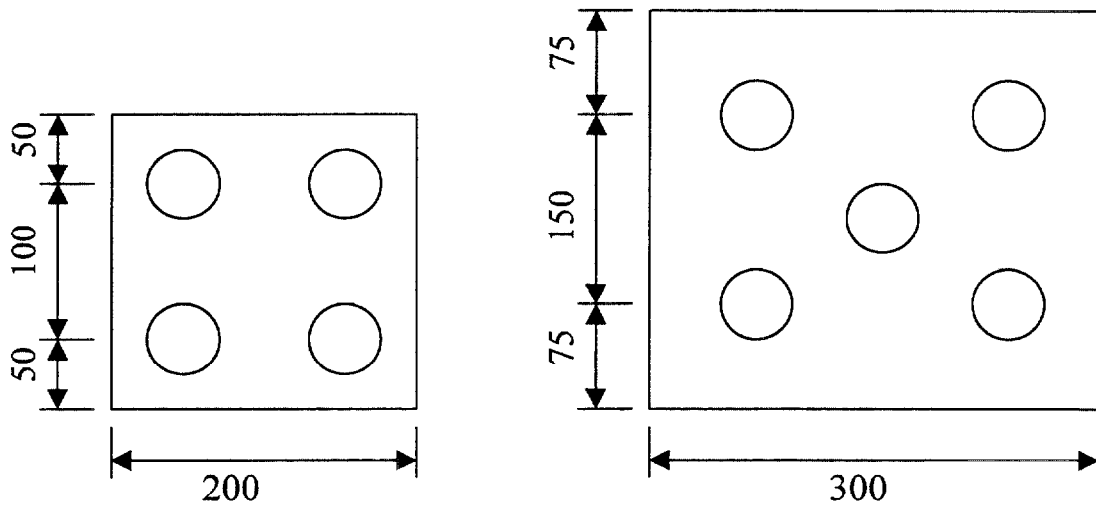


Figure 10. Examples of spacing the test sites on a specimen, dimensions in mm.

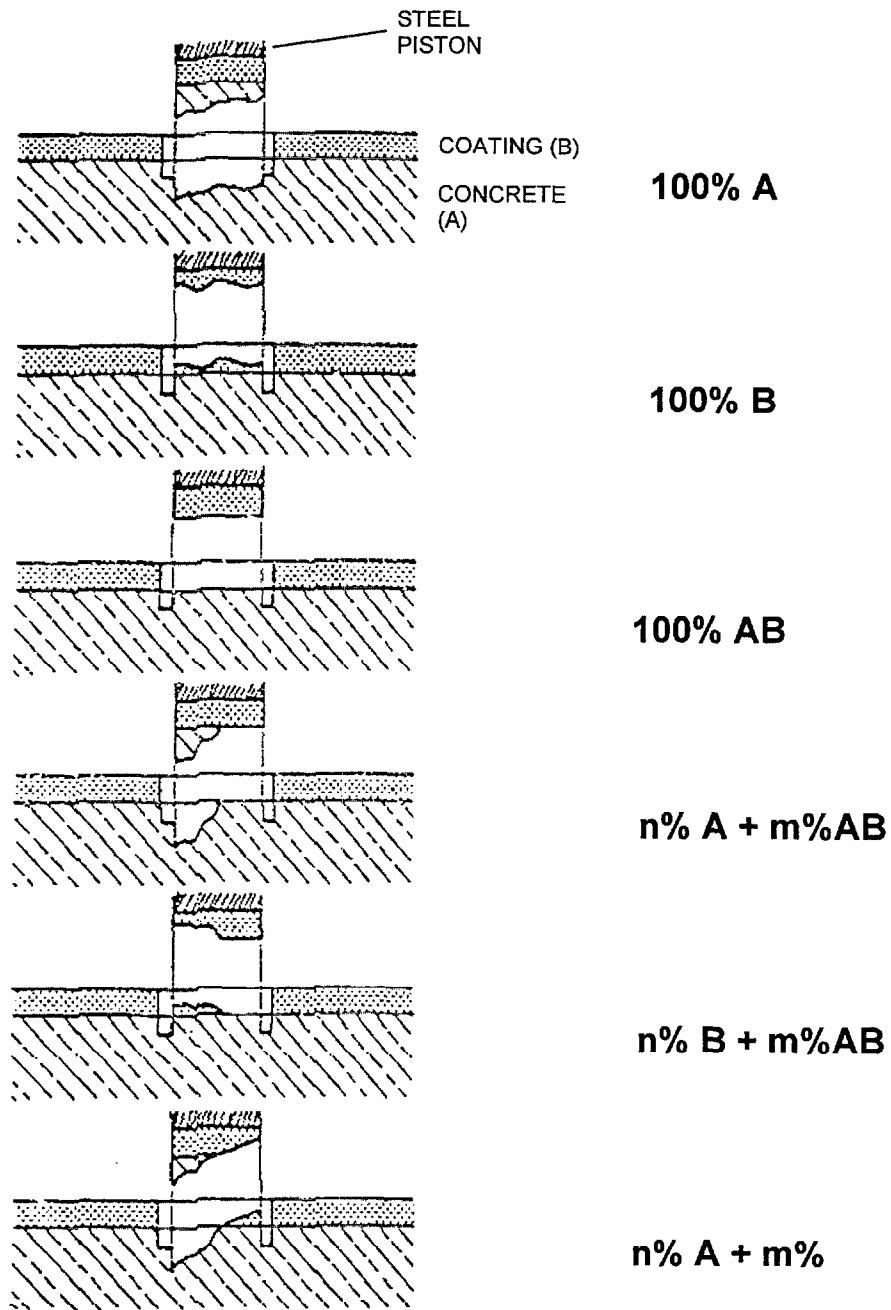


Figure 11. Modes of failure in adhesion test (see Sec. 4.2).

Adhesion between polymer composites and a concrete substrate can be determined also by measuring the tensile strength in a uniaxial test. The test specimen consists of two halves of a concrete sample, bonded together by the repair composite material to be tested, as shown schematically in Fig.12. This test can be useful in the case of injection composites as well as high elastic sealing composites.

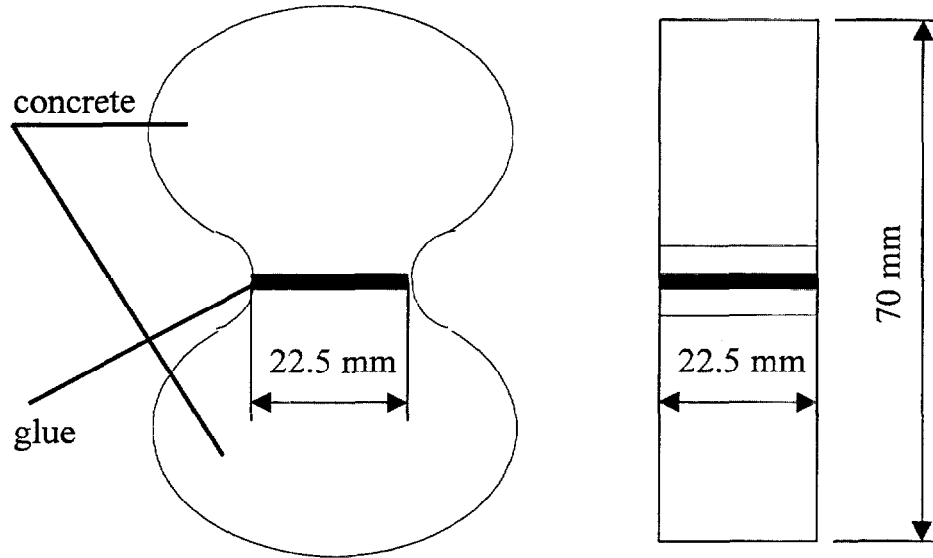


Figure 12. The specimen shape for adhesion determination by a uniaxial tensile test

#### 4.2.2 Dynamic loading test

The aim of this test is to determinate the adhesion of a polymer composite that is cured under dynamic loading. This test is an attempt to simulate the situation prevailing in a repair of a concrete bridge while under traffic load. Figure 13 shows the details of the test specimen used. The dynamic loading forces are applied under the following conditions: distance of loading points from the bearing = 350 mm, size of load = 8 kN - 40 kN, the frequency of variation of loading = 4.2 Hz, and the duration of loading = 24 h. After the duration of the test, the repair material is visually inspected for cracks and delamination from the concrete substrate.



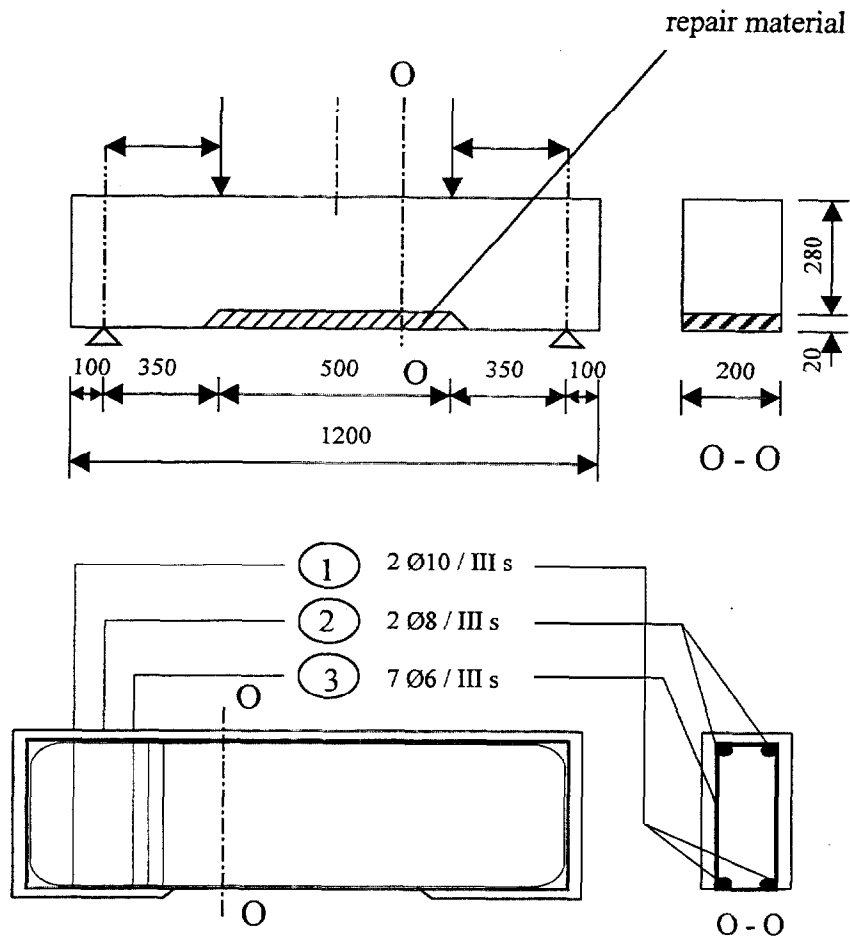


Figure 13. Geometry and scheme of loading concrete beam after repairing, dimensions in mm.

1,2,3 – reinforcement shown in bottom half of figure.

#### 4.2.3 Slant shear test

This test determines the bond strength of polymer-based repair materials to portland cement concrete in a slant shear geometry. The bond strength is determined on a composite prism, as is shown in Fig. 14. After suitable curing the test is performed by applying a compressive force on the composite prism. The test is used for the following combinations: old concrete glued to old concrete, fresh concrete glued to old concrete, and repair material glued to old concrete with or without a primer.

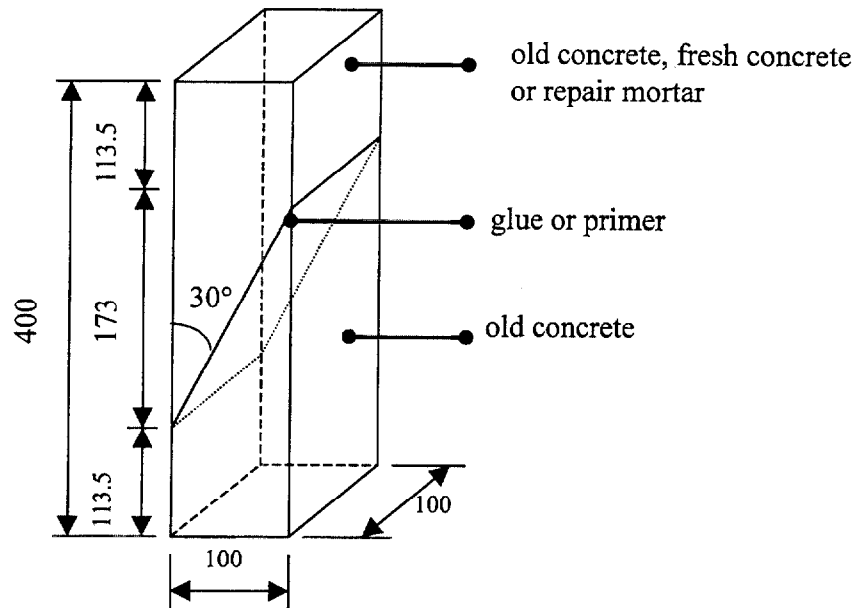


Figure 14. Geometry and shape of the slant shear test specimen, dimensions in mm. Surface area of section 100 mm x 100 mm.

The load at rupture and the mode of failure is recorded. Possible failure modes are: normal type of rupture as found in non-composite cylinders or cubes, or rupture following a slide plane that more or less coincides with the slant plane. In this case an estimate has to be made of the kind of failure, to the nearest 25 % of the different materials and interfaces: A = cohesive failure within the concrete substrate, old or new, A/B = adhesive failure between primer or glue and concrete, old or new, and B = cohesive failure within the glue or primer.

#### 4.2.4 Direct shear test

The aim of the direct shear test is the determination of the shear bond strength of bonded prisms, which represent various kinds of composite joints. Figure 15 shows a schematic view of the test specimen used. A bonded prism is tested in a compressive test machine and the joint is thus subject to a combination of shear, tensile and compressive stresses, whose ratio depends on the thickness of the bond layer,  $t$ , and the stiffness of the adhesive.

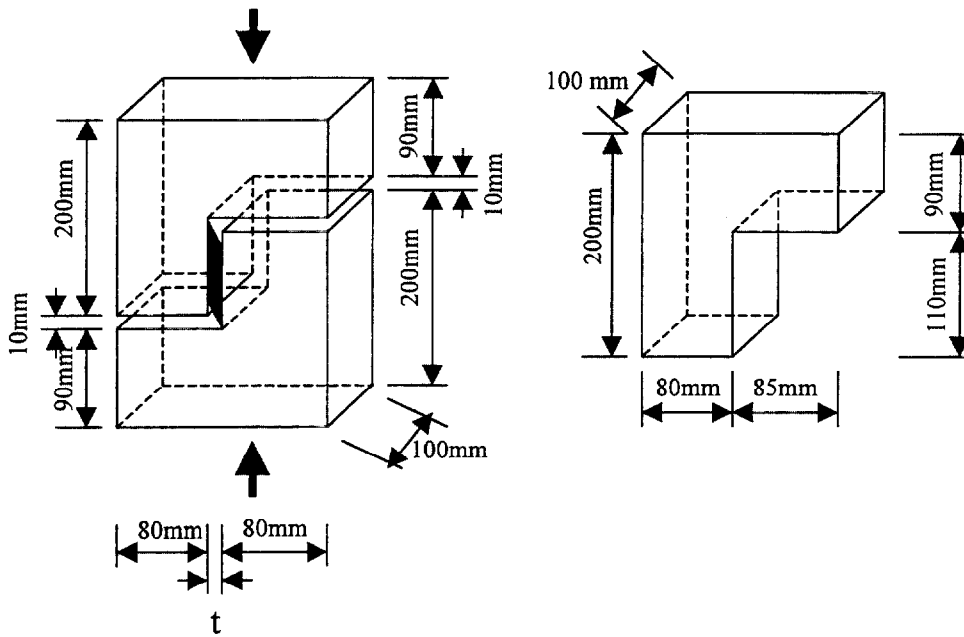


Figure 15. Geometry of direct shear test specimens. Surface area of adhesion 100 mm x 100 mm.

The strength and the mode of failure is recorded. The possible failure modes are shown in Fig.16: A = cohesive failure within the concrete substrate, A/B = adhesive failure between the adhesive and concrete substrate, and B = cohesive failure within the adhesive.

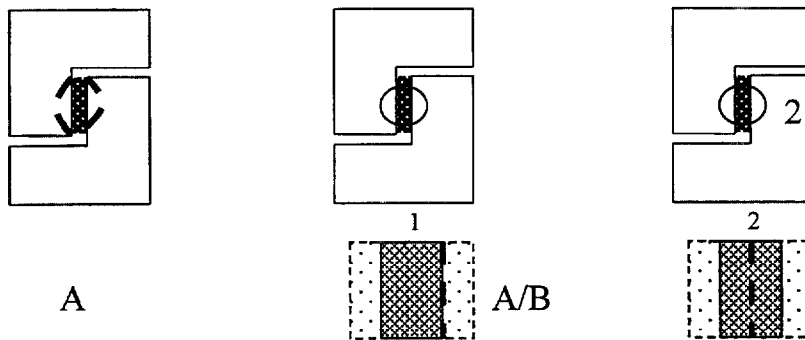


Figure 16. Modes of failure for direct shear test.

#### 4.2.5 Thermal compatibility tests

These tests determine the thermal behavior of a polymer composite coating covering a portland cement concrete substrate.

##### Thermal compatibility test (I)

The thickness of the polymer coating should be at least 0.1 mm. The behavior under freeze-thaw conditions as well as under thermal shock can be tested. The minimum dimension of the concrete-coating interface should be in accordance with the number of tests to be performed on one concrete specimen (cube or slab), but not less than 200 mm. The thickness of the substrate should be at least 100 mm. The quality of the concrete substrate specimen should be such that the cube compressive strength is at least 50 MPa after 28 d. Concrete shall be prepared from aggregates having a maximum grain size of 16 mm. The concrete substrate may be wet or dry according to the type of coating. In the standard case, the side faces of the coated specimen shall not be sealed. If the field application does not correspond to unsealed joints the side faces may be sealed in the test. The freeze-thaw cycles as well as the thermal shock shall be carried out in two steps on different specimens.

In the freeze-thaw test, the specimens are alternately submerged for one hour each in water of  $(20 \pm 2) ^\circ\text{C}$  and in a salt-water solution of approximately  $(18 \pm 2) ^\circ\text{C}$  (see Fig. 17a). The cycling begins with normal temperature immersion and lasts 200 h (100 cycles). The specimens should always be put in a vertical position, as is shown in Fig. 17b.

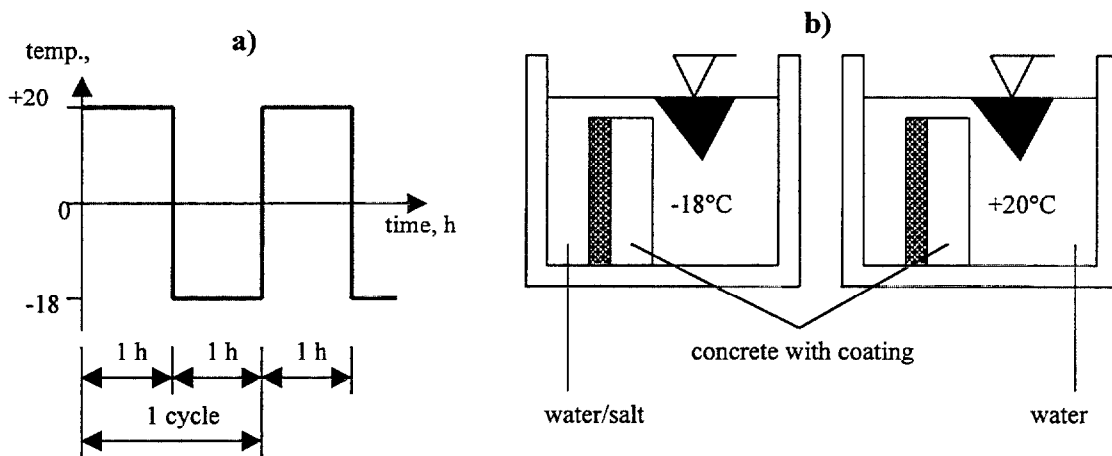


Figure 17. Freeze-thaw test: a) cycle configurations, b) placement of specimen

In the thermal shock test each thermal shock cycle consists of a heating phase for six hours in air at a temperature of  $(60 \pm 2) ^\circ\text{C}$  and  $(95 \pm 5) \% \text{RH}$ , followed by a 10 minute-long artificial rain shower (total water volume applied of about 30 L/min to 40 L/min with a water temperature of  $(10 \pm 2) ^\circ\text{C}$ ). The complete thermal shock test lasts 50 cycles (see Fig. 18a). During the artificial rain shower the specimen should be placed in a horizontal position on an iron lattice support, as is shown in Fig. 18b. A sprinkler nozzle is fixed a distance of 300 mm - 500 mm above the coated surface.

The coating is visually evaluated after each cycle, noting any delamination, cracks, bubbles or other failures. After the test cycles are completed the samples are subjected to the pull-off test (see Sec. 4.2.1).

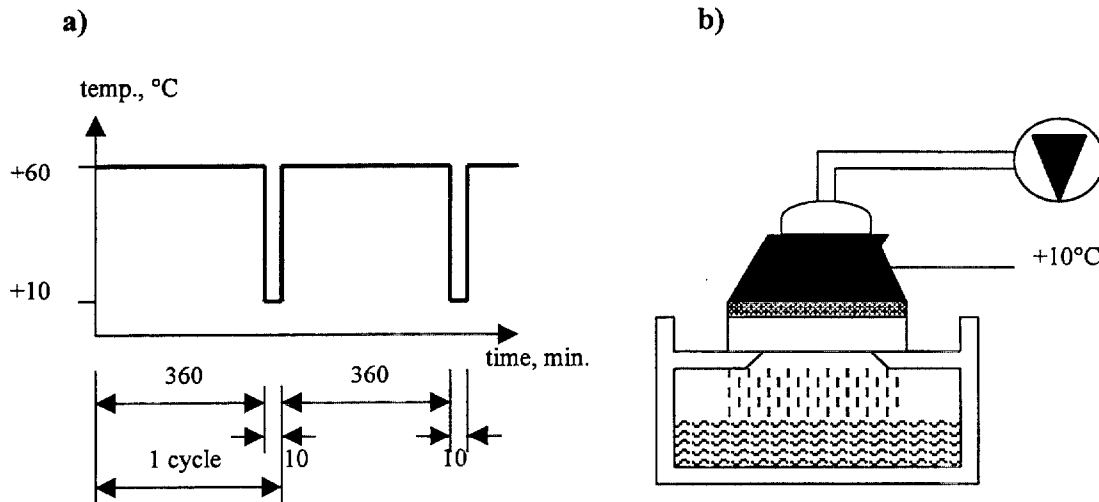


Figure 18. Thermal shock test: a) cycle configuration, b) placement of specimen.

### Thermal compatibility test (II)

This test defines the procedure for the determination of the adhesion of coatings with thickness up to 10 mm. Adhesion is measured in terms of the tensile stress required to remove or cause failure of a cylindrical section of surface coating that has been severed from the surrounding coating.

The minimum dimensions and shape of the concrete substrate specimen should be in accordance with the number of tests to be performed on one concrete specimen (cube or slab), but not less than 200 mm. The thickness of the substrate shall be at least 100 mm. The quality of the concrete substrate specimen shall be such that the cube compressive strength is at least 50 MPa after 28 d. The concrete should be prepared from aggregates having a maximum grain size of 16 mm. The concrete substrate can be wet or dry according to the type of coating. Three test specimens are required for tests on the dry support, three more for the tests on the wet support. Before the test, specimens should be placed for a minimum of 24 hours in standard laboratory conditions at  $(20 \pm 2)$  °C and  $(65 \pm 5)$  %RH. In the standard case, the side faces of the coated specimen are not be sealed. If the field application does not correspond to unsealed joints, the side faces may be sealed in the test.

The thermal cycles carried out are illustrated in Fig. 19, with a total of 100 cycles. The coating should be visually evaluated after each cycle, noting any delaminations, cracks, bubbles or other failures. After the test cycles the samples shall be subjected to the pull-off test (see Sec. 4.2.1).

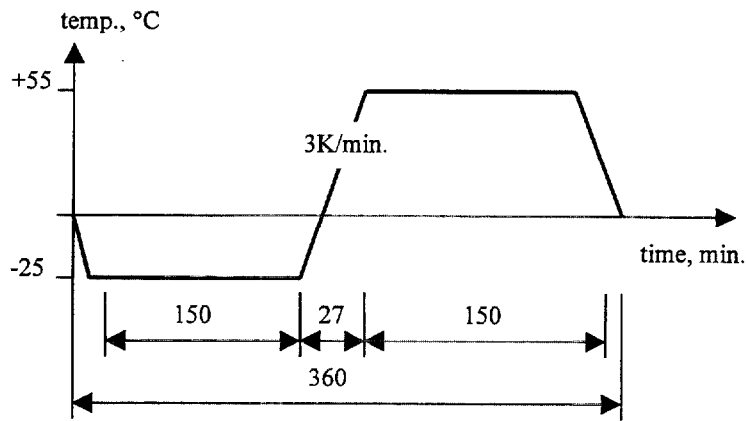


Figure 19. Thermal cycles for thermal compatibility test II.

#### 4.2.6 Four-point bending test

This test is recommended for determination of the adhesion of coatings with thickness up to 10 mm on a concrete substrate. The principle of the test consists of applying the polymer composites filling a recess made on one of the surfaces of a prismatic concrete test piece (Fig. 20) and subjecting the specimen to a four point bending strength test.

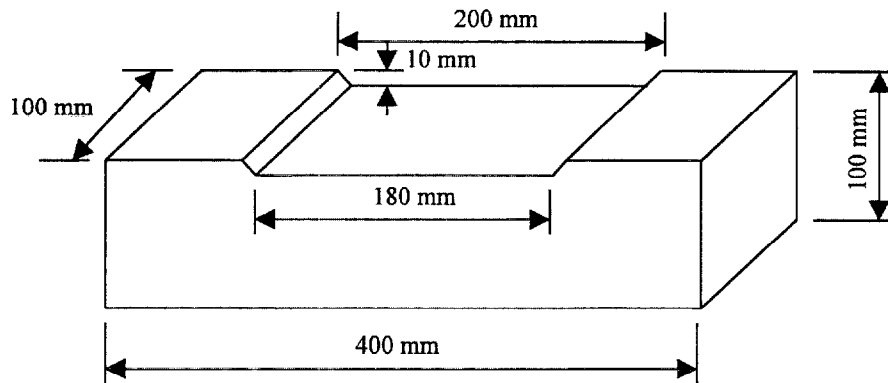


Figure 20. Geometry of specimen for four-point bending test

The quality of the concrete substrate specimen should be such that the cube compressive strength is at least 50 MPa after 28 d. The concrete should be prepared from aggregates having a maximum grain size of 16 mm. The system with the coating in place should be conditioned for seven days in standard laboratory conditions at  $20 \pm 2$  °C and  $65 \pm 5$  %RH.

During mechanical tests, the filled side of the specimen is placed on the bottom support (tension side of the specimen) of the loading apparatus, as is shown in Fig. 21. The rate of loading

should be constant during the whole duration of the test and equal to 0.05 MPa/s with a tolerance of 0.01 MPa. The strength and the mode of failure must be recorded. The possible modes are shown in Fig.22, which define whether a repair is compatible or incompatible.

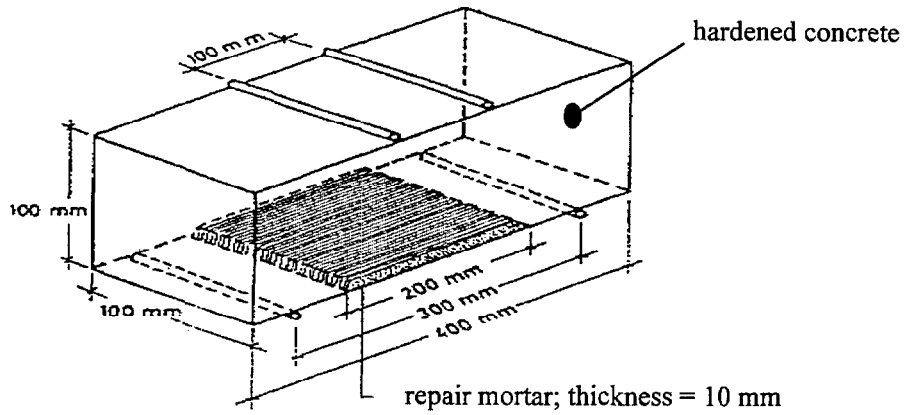


Figure 21. Sample arrangement for 4-point bending test.

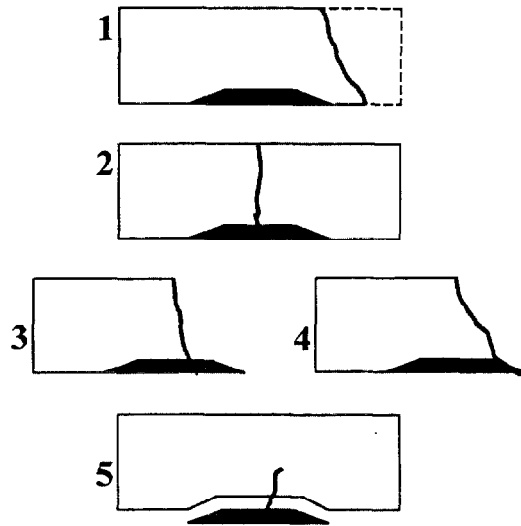


Figure 22. Modes of failure. Compatibility evaluation: 1,2 – compatibility; 3, 4, 5 – incompatibility.

### 4.3 Determination of adhesion between concrete substrates and selected types of repair composites

The previous section described the kinds of adhesion testing that was used in the validation program. Not all tests were performed on all samples. Preliminary adhesion testing was carried out to obtain knowledge of what were some of the important variables, and as a qualitative check of the inequalities and material control parameters that were built into the program. Specific tests were then carried out and compared directly to the predictions of the Compatibility program.

#### 4.3.1 System characterization – preliminary tests

Preliminary tests of adhesion between polymer composite repair materials and portland cement concrete substrates have been carried out for five types of repair systems (Table 4): I) polymer modified cement composites (concrete or mortar), II) polymer-cement composites (concrete or mortar), III) polymer composites (concrete or mortar), IV) injection polymer composites (non-filled composites), and V) high elastic polymer composites (non-filled composites). Only substrates of the B25 class were used in this preliminary testing. The designation “B25” means that the compressive strength was at least 25 MPa at 28 d.

Table 4. Basic technical properties determined for particular repair composites

Type of composites	Workability time min	Linear shrinkage %	Compressive strength MPa	Flexural strength MPa	Tensile strength MPa	Adhesion, MPa	
						in tension	in shear
I) polymer modified cement mortar	30	0.04	54.2	16.7	--	1.6	5.6
II) epoxy-cement mortar	50	0.03	41.6	27.4	--	2.2	6.6
III) vinyl-ester concrete	30	0.23	71.2	28.6	12.8	3.6	12.3
IV) polyurethane injection composite - non-foamed - foamed,	1.5	0.25	79.0	78.1	2.3	2.7	9.8
	2.0	0.90	25.1	9.6	24.6	1.2	3.2
V) high elastic polyurethane composite	100	0.60	1.6 (at strain of 50%)	--	1.1	0.9	1.0

The adhesion between concrete substrates and various types of repair composites was determined for two cases (see Table 4). Case 1 was to test the adhesion in tensile conditions (loading perpendicular to the composite-concrete contact zone) using a uniaxial tensile test for specimens bonded by repair composites of types IV and V. The load at failure, divided by the measured value of the cross sectional area at failure, was used to calculate the failure tensile stress. For repair material types I and II, the pull-off test (see Sec. 4.2.1) was used. Case 2 was to test the adhesion



between repair material and substrate in shear conditions (see Fig. 14 in Sec 4.2.3). The combinations of old and fresh concrete substrates with repair material III, and two specimens of an old concrete substrate bonded with repair material V, have been tested.

The results obtained, shown in Table 5, indicate that adhesion between polymer composite repair materials and portland cement concrete substrates is sensitive to whether the substrate surface was dry or wet, and whether a primer was used to promote adhesion between the two materials. These results indicate the necessity of proper preparation of the concrete substrate.

The next sections describe the results of specific tests that were used to directly compare to the Compatibility program results. A figure showing the test results as well as the compatibility subspace is given for some tests, for the three kinds of situations studied: structural surfacing, crack injection, and coatings. For some tests, only a picture of the experiment or the compatibility space is given, but full results are given in the accompanying tables. In all cases, the prediction of the Compatibility program, either compatibility or incompatibility, depending whether the material parameters were inside or outside the compatibility space, were verified by the experimental results. Note that the tests chosen for each situation corresponded to probable applications of the given polymer composites.


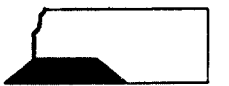


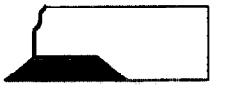



Table 5. Adhesion to concrete substrate of the particular types of repair composites

Type of composites	Adhesion to concrete substrate			Mode of failure	Remarks
	mean value, MPa	standard deviation, MPa	coefficient of variation, %		
I) polymer modified cement mortar	1.6	0.15	1.6	cohesive failure within composite	--
II) epoxy-cement mortar	> 3.0	--	--	cohesive failure within concrete substrate	--
III) vinyl-ester concrete	16.4	2.55	15.6	cohesive failure within concrete substrate	--
IV) polyurethane injection composite - non-foamed - foamed,	1.3 1.2	0.29 0.36	22.3 29.0	combined failure of adhesive-cohesive type	wet concrete substrate results in adhesion decreasing about 50% with high variation of results
V) high elastic polyurethane composite: - in tensile condition - in shear condition	0.90 1.00	0.11 0.12	12.3 12.0	cohesive failure within composite	adhesion decreasing for non-cleaned substrate and joint without primer

#### 4.3.2 Laboratory verification of structural surfacing predictions

Three types (A, B, C) of epoxy and two types (D, E) of acrylic repair composites have been used in the full test program, which included thermal and freeze/thaw tests. A summary of the final results has been presented in Table 6 and illustrated in Figs. 23-30. The results obtained confirmed the practical usefulness of the Compatibility program to accurately evaluate the compatibility of repair materials and substrates in this repair situation. In Table 6, C = compatible, IC = incompatible.

Table 6. Measurement of the adhesion of the repair materials to the concrete substrate

Repair material	Test	Thickness of concrete loss [mm]	Mode of failure	Compatibility evaluation	Flexural strength, MPa
A	Bending	15		C; see Figs. 23 & 24	9.2
		30			9.7
	Bending + thermal cycle	30		IC; see Fig. 25	6.8
B	Bending	15		IC; see Figs. 26 & 27	8.3
		30			6.7
C	Bending	15		C	11.2
		30			11.3
	Bending + thermal cycle	30			13.0
D	Bending	15		IC; see Fig. 28	6.4
E	Bending	15		C	5.6
		30		C/IC see Fig. 29	5.4
	bending + thermal cycle	30		C; see Fig. 30	3.6

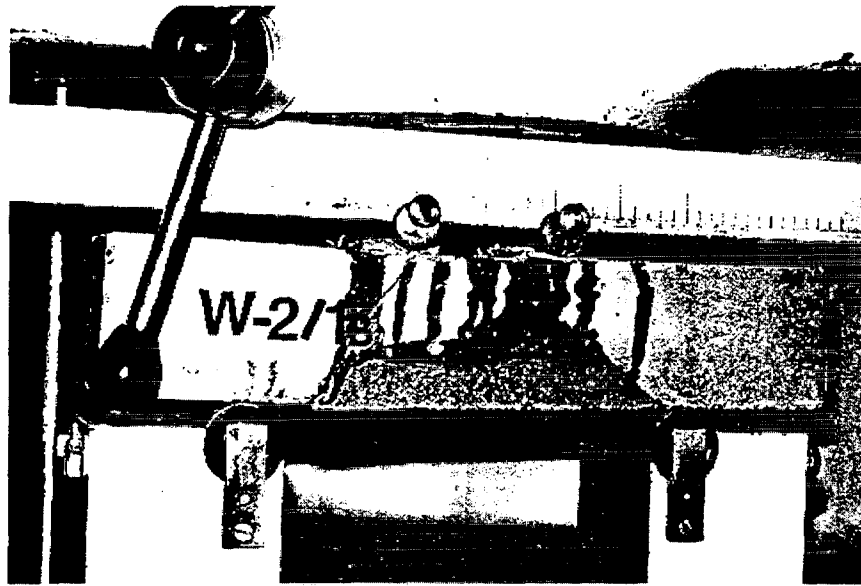


Figure 23. Fracture of the beam with a loss of 30 mm depth of substrate, filled by type A repair material.

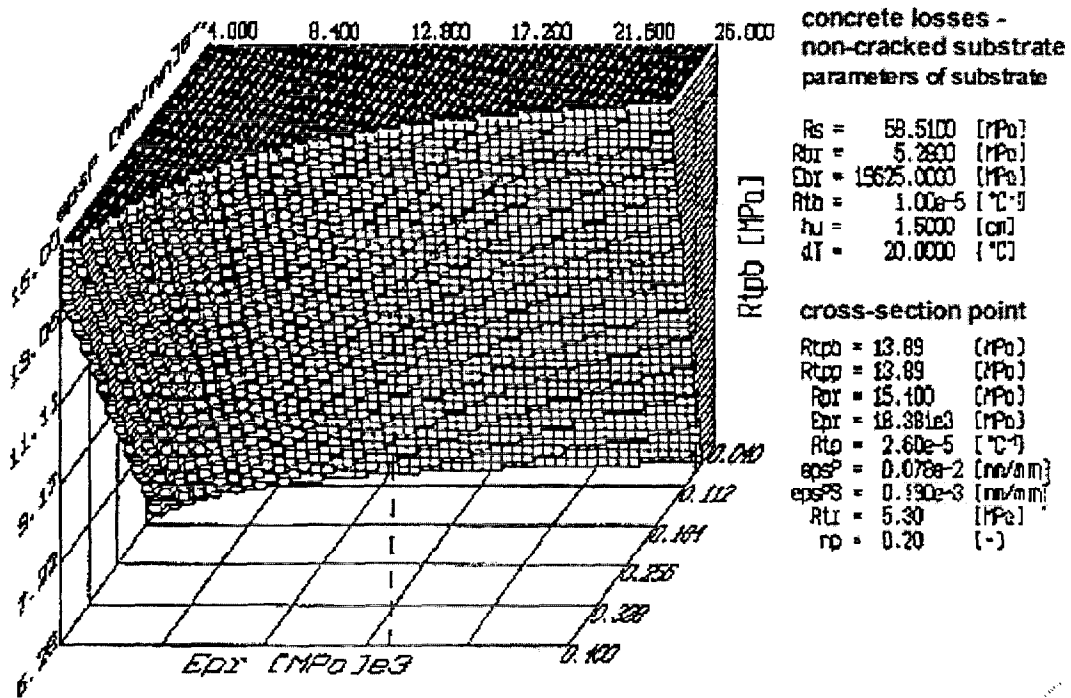


Figure 24. Compatibility subspace for the portland cement concrete substrate and repair material A, where the axes are modulus of elasticity, adhesion to concrete and ultimate strain. The marked point (not shown) corresponds to the properties of repair material type A, which is inside the compatibility space.

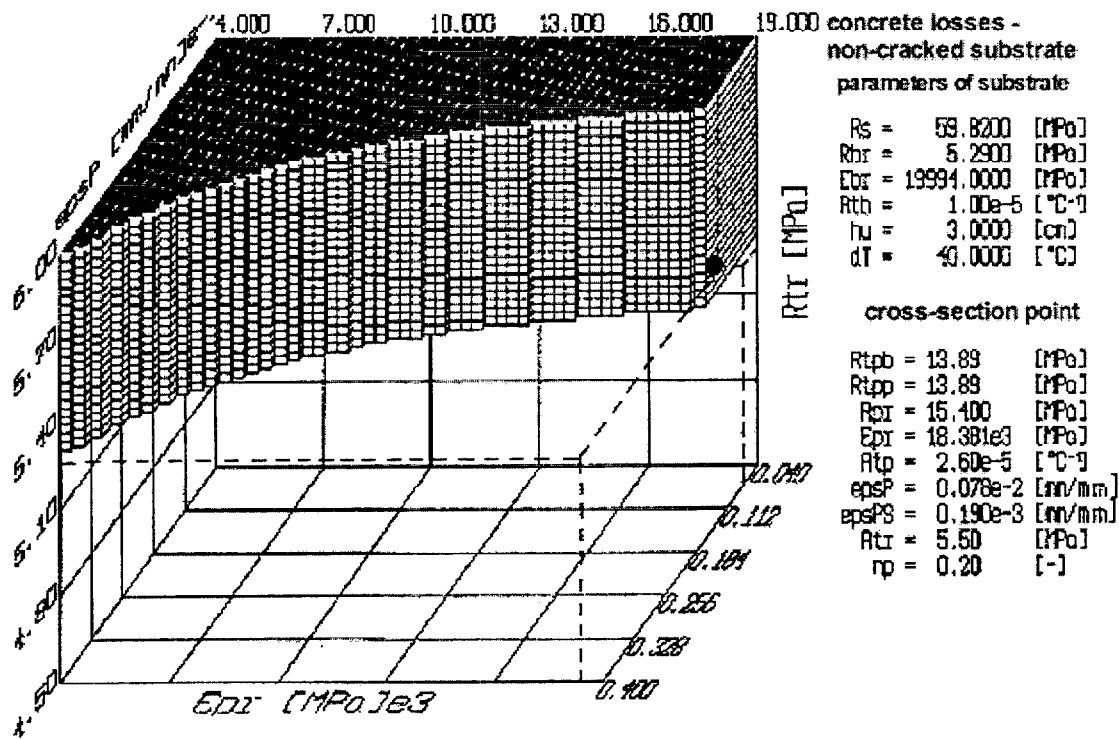


Figure 25. Compatibility subspace for repair material A and the portland cement concrete substrate under thermal load. The axes of the subspace are modulus of elasticity, adhesion to concrete and ultimate strain. The marked point corresponded to the properties of repair material type A, which fell outside the compatibility space.

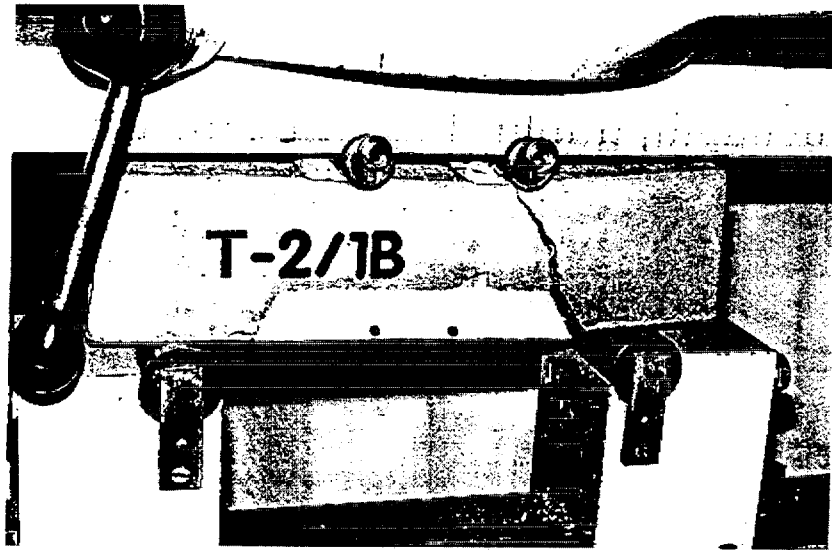


Figure 26. Fracture of the beam with a loss of 30 mm depth of substrate, filled by type B repair material.

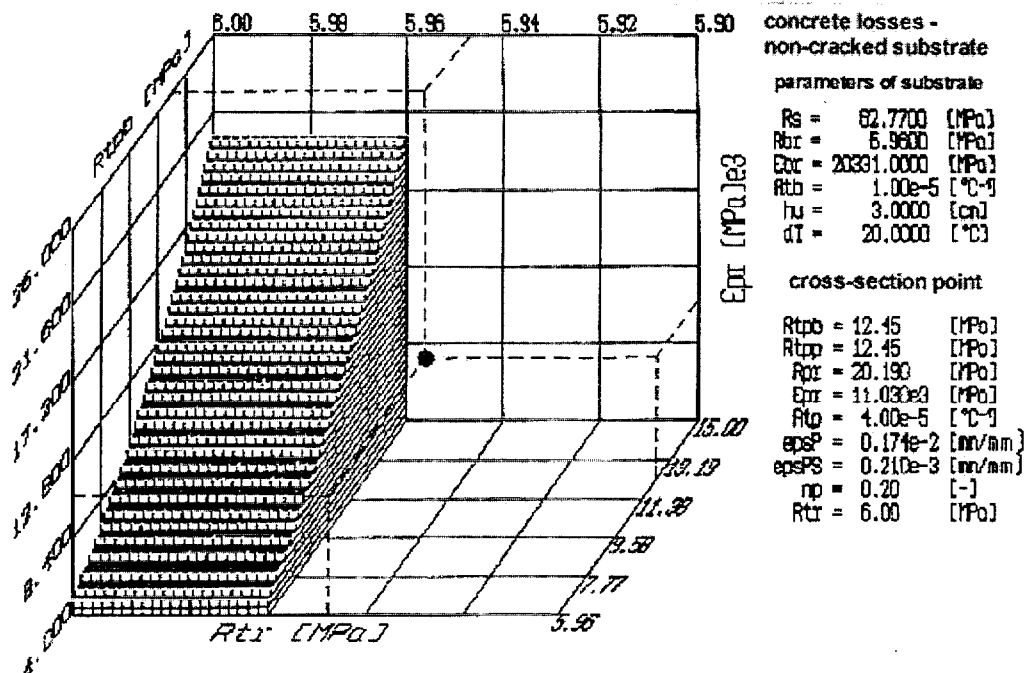


Figure 27. Compatibility subspace for repair material B and the portland cement concrete substrate under thermal load. The axes of the subspace are modulus of elasticity, pull-off strength, and adhesion to concrete in shear condition. The marked point corresponds to the properties of type B repair material, which fell outside the compatibility subspace.

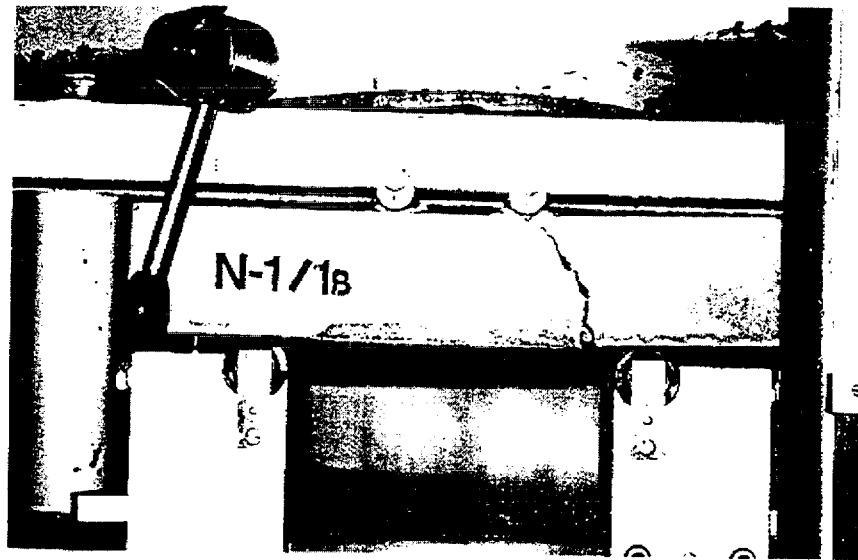


Figure 28. Fracture of the beam with a loss of 15 mm depth of substrate, filled by type D repair material.

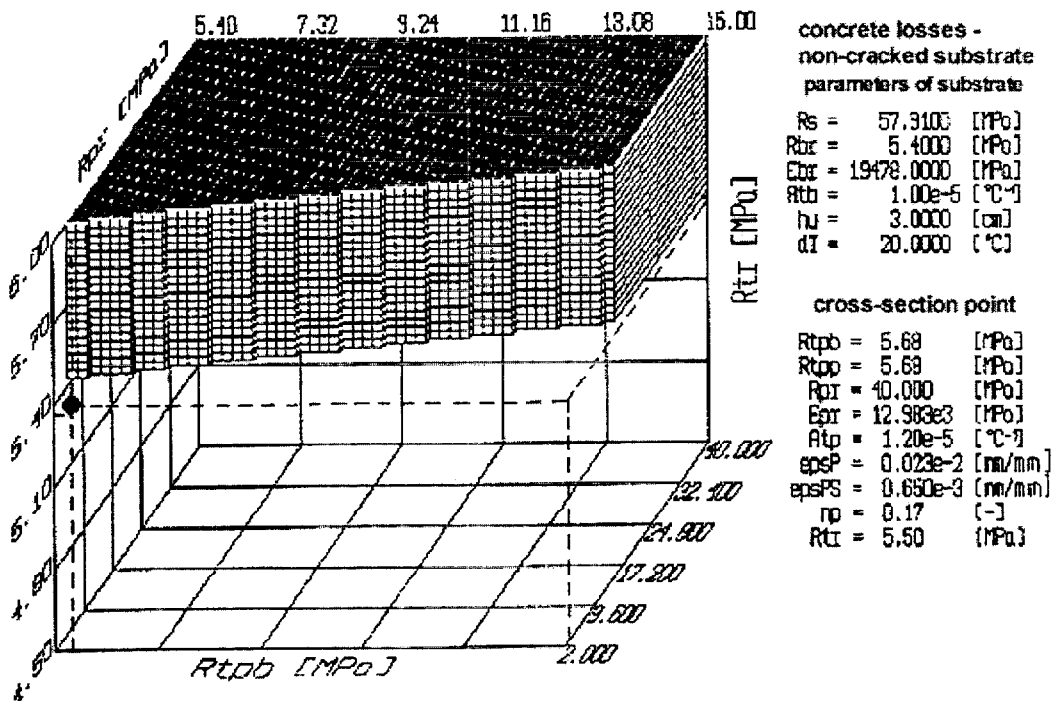


Figure 29. Compatibility subspace for repair material E and the portland cement concrete substrate under thermal load. The axes are pull-off strength, adhesion to concrete in shear condition, and tensile strength. The marked point corresponds to the properties of type E repair material, which fell outside the compatibility subspace.

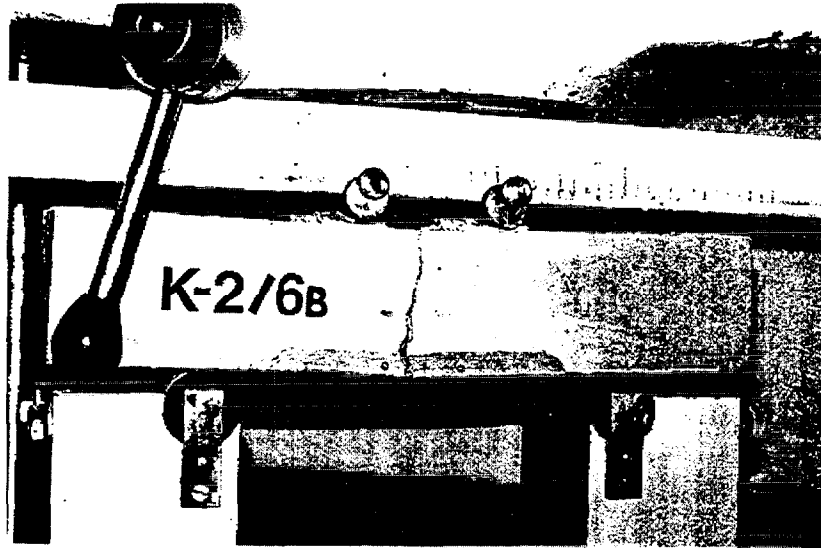


Figure 30. Fracture of the beam with a loss of 30 mm depth of substrate, filled by type E repair material.

#### 4.3.3 Laboratory verification of coatings on portland cement concrete

##### 4.3.3.1 Materials and test methods

The polymer (acrylic) cement coating has been evaluated according to the full test program, including thermal and freeze/thaw tests.

The main part of the laboratory work has included the testing of protective coatings covering reinforced concrete beams (100 mm x 100 mm x 500 mm). The beams had been stored at a temperature of  $(20 \pm 2)$  °C and 100 %RH for 28 d, after which the tested coating was applied to the beam surface. The repaired beams and plates were then kept at  $(20 \pm 2)$  °C and 65 %RH. The bending tests have also been carried out for the repaired beams after 25 thermal cycles (360 min at +50 °C and 15 min at +10 °C). The beams have been tested freely supported, loaded by two concentrated forces placed at 1/3 of the span. The destructive force and the failure mode (adhesive-delamination, cohesive in the concrete, cohesive in the coating) were determined.

The properties of the coating and the concrete were determined in a complementary part of the testing. The samples of concrete (150 mm cubes for mechanical strength and 50 mm x 250 mm x 250 mm plates for adhesion tests) have been stored in the same way as were the beams.

##### 4.3.3.2 Test results and analysis

The compressive strength of the concrete ranged from 33 MPa to 48 MPa, and the tensile strength ranged from 2.0 MPa to 4.0 MPa. The values of the properties of the coating, important for their compatibility, were also determined (Table 7).



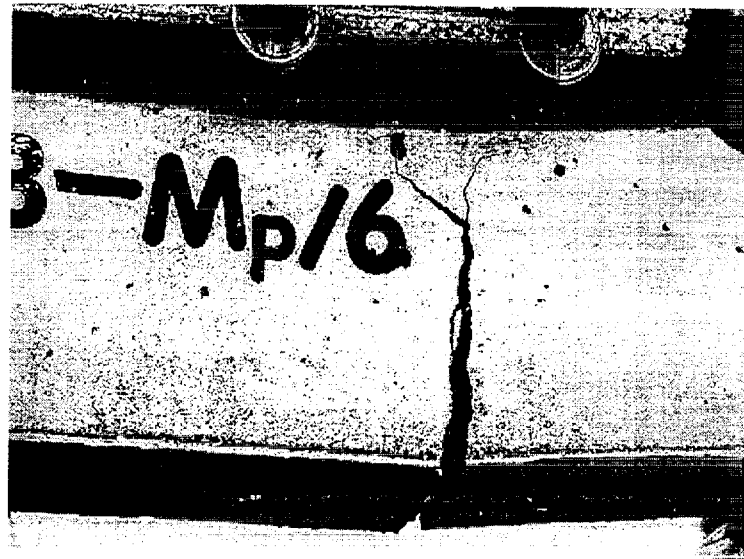
Table 7. Properties of the coating material

Material	h [mm]	$R_{\tau}^{p/b}$ [MPa]	$R_{pr}^{p/b}$ [MPa]	$R_{pr}$ [MPa]	$E_{pr}$ [MPa]	$\alpha_{pr}$ [1/K]	$\varepsilon_s$ [%]	$\varepsilon_{pr}$ [%]
Storage at normal condition								
MP-1	2.8	1.7 <sup>1)</sup>	4.5	6.2	109.5	$2.9 \cdot 10^{-5}$	0.25	4.2
After 25 freeze/thaw cycles								
MP-1	2.9	1.3 <sup>2)</sup>	4.1	6.4	154.0	$2.9 \cdot 10^{-5}$	0.25	3.2
$R_{\tau}^{p/b}$ – adhesion to the concrete substrate at shear $R_{pr}^{p/b}$ – adhesion to the concrete substrate at tension (pull-off) $R_{pr}$ – tensile strength $E_{pr}$ – modulus of elasticity at tension $\alpha_{pr}$ – thermal expansion coefficient $\varepsilon_s$ – hardening shrinkage $\varepsilon_{pr}$ – maximum elongation at tension h – coating thickness 1) – destruction in the concrete and coating (cohesive failure, no delamination) 2) – destruction between coating and concrete substrate (adhesive failure; delamination)								

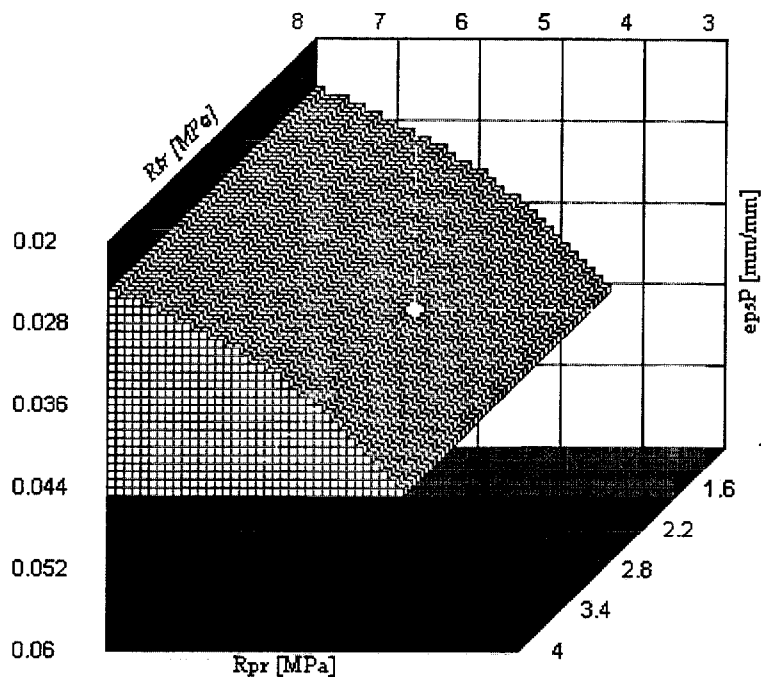
The freeze/thaw test was the decisive factor that classified materials into incompatibility and compatibility classifications. All the beams covered by a tested coating failed as a result of a crack across the concrete and coating. Delamination was not observed. Figure 31a shows a coated beam that had such a failure mode. Adhesive failure was only found for the beams tested after the freeze-thaw cycles. An example is shown in Fig. 32a.

The compatibility space was determined on the basis of the material control parameters for the coated systems. The compatibility subspaces corresponding to Figs. 31a and 32a are shown in Figs. 31b and 32b, respectively. A crack with a potential maximum width of 0.2 mm has been implemented into the compatibility model.

The results of laboratory tests (Fig. 31a, 32a) have shown good conformity to the theoretical calculations (Fig.31b, 32b). Cohesive failure with no delamination clearly corresponds to the compatibility stage, while adhesive failure, accompanied by delamination of the coating, corresponds to the incompatibility stage, as expected.

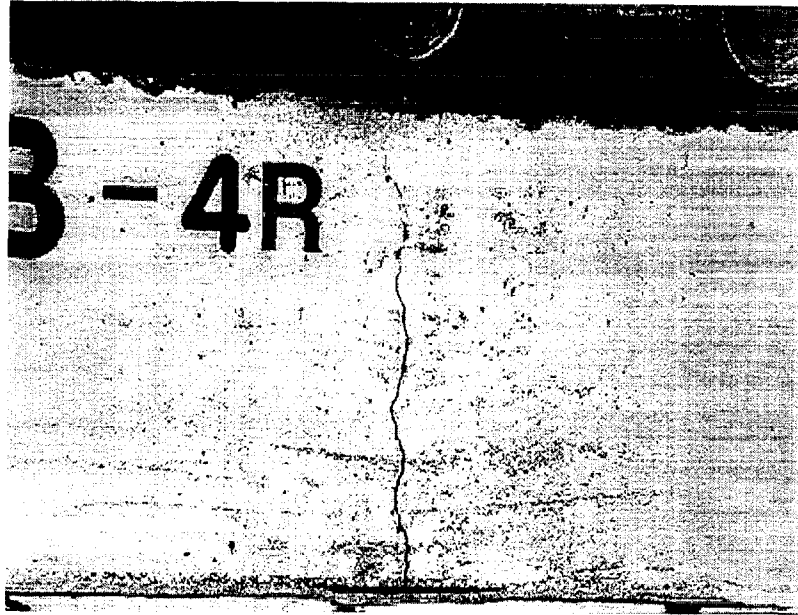


a)

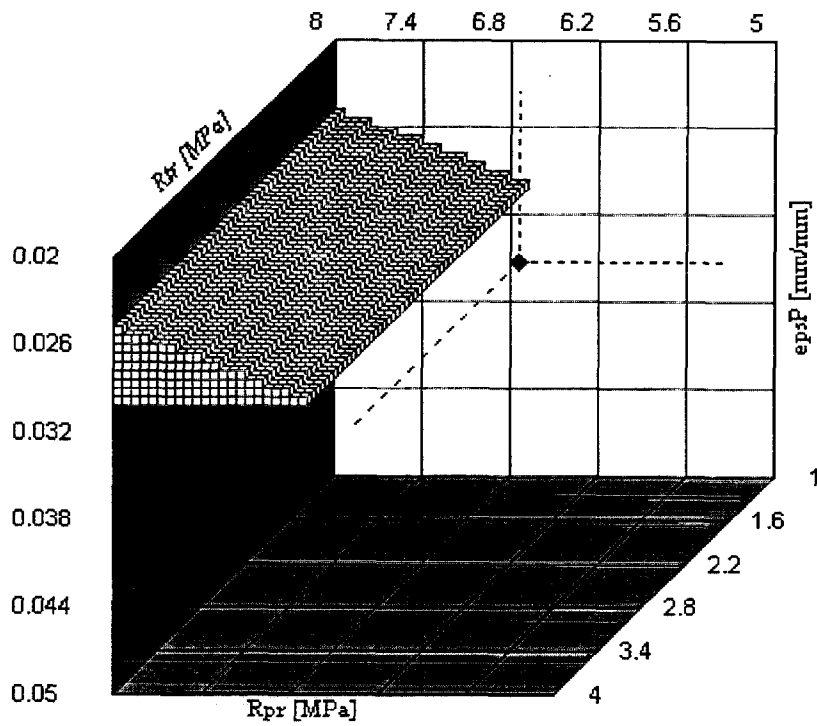


b)

Figure 31. Cohesive failure in the crack zone for a coating stored at normal conditions (a) and the compatibility subspace (b). The marked point is inside the compatibility subspace, predicting compatibility of the coating/substrate system.



a)



b)

Figure 32. Adhesive failure with coating delamination after freeze/thaw test (a) and the compatibility subspace (b). The marked point is outside the compatibility subspace, predicting in compatibility of the coating/substrate system.

#### 4.3.4 Laboratory verification of crack injection repair situation and materials

##### 4.3.4.1 Materials and test methods

Four injection materials, available commercially, were selected for testing: a three-component cement-polymer material ICP-1 ( $w/c = 0.6$ ), a two-component polyurethane resin IP-2, and two-component epoxy resins IP-1 and IP-3. The main part of the laboratory work consisted of flexural testing of reinforced concrete beams (100 mm x 100 mm x 400 mm) with artificially formed cracks of 6 mm and 45 mm width (see Fig. 33 for the geometry), extending halfway through the span. The beams were cured at  $(20 \pm 2) ^\circ\text{C}$  and 100 %RH for 28 d, after which the cracks were injected with the tested materials. The repaired beams were then stored at  $(20 \pm 2) ^\circ\text{C}$  and 65 %RH until testing. The bending tests were carried out for the as-cured repaired beams, and also after 50 thermal cycles (360 min at  $+50 ^\circ\text{C}$  and 15 min at  $+10 ^\circ\text{C}$ ) and after 25 cycles of freezing and thawing. The beams have been tested freely supported, loaded by two concentrated forces placed at 1/3 of the span. The load at failure and the failure mode (adhesive, cohesive in the concrete, cohesive in the injected crack) were determined. The strain of the injection materials in the crack was also measured using a tensiometer with a measurement basis of 20 mm and accuracy of 0.001 mm.

The separate properties of the injection materials and the concrete (materials control parameters) were determined in a complementary part of the testing. The samples of concrete (150 mm cubes for mechanical strength and 50 mm x 250 mm x 250 mm plates for adhesion tests) were stored in the same way as the tested beams.

##### 4.3.4.2 Test results and analysis

The compressive strength of the concrete ranged from 33 MPa to 48 MPa, and the tensile strength ranged from 2.0 MPa to 4.0 MPa. The values of the properties of the injection materials, which were used as material control parameters, were also determined, both before and after the freeze/thaw and thermal cycles, and are listed in Tables 8 and 9. We estimate the uncertainty in all measured quantities to be approximately 10 %. Tables 8 and 9 also contain the test results on the compatibility of the model crack injection repairs.

Table 8. Properties of the injection materials before cycling

Material	$R_t^{p/b}$ [MPa]	$R_{pr}^{p/b}$ [MPa]	$R_{pr}$ [MPa]	$E_p$ [MPa]	$E_{pr}$ [MPa]	$\alpha_{pr}$ [1/K]	$\varepsilon_s$ [‰]	$\varepsilon_{pr}$ [%]
ICP-1	0.9 <sup>1)</sup>	<< 4.0	1.3	1235	-	$2.2 \cdot 10^{-5}$	3.1	0.023
IP-1	> 2.0 <sup>2)</sup>	> 2.9	35.9	1622	216	$8.8 \cdot 10^{-5}$	0.45	18.2
IP-2	> 1.7 <sup>2)</sup>	> 3.1	0.3	-	2.03	-	4.8	39
IP-3	> 1.6 <sup>2)</sup>	> 2.0	12.8	2130	117	$6.7 \cdot 10^{-5}$	0.36	28

$R_t^{p/b}$  – adhesion to the concrete substrate (pull-off test)  
 $R_{pr}^{p/b}$  – adhesion to the concrete substrate (bending of the injected beams)  
 $R_{pr}$  – tensile strength  
 $E_p$  – modulus of elasticity at compression  
 $E_{pr}$  – modulus of elasticity at tension  
 $\alpha_{pr}$  – thermal expansion coefficient  
 $\varepsilon_s$  – hardening shrinkage  
 $\varepsilon_{pr}$  – maximum elongation at tension  
 1) – adhesive failure between injection material and concrete substrate  
 2) – cohesive failure in the concrete, beyond the place of binding



Table 9. Properties of the injection materials after thermal and freeze/thaw cycles

Material		$R_t^{p/b}$ [MPa]	$R_{pr}^{p/b}$ [MPa]	$R_{pr}$ [MPa]	$E_p$ [MPa]	$E_{pr}$ [MPa]	$\varepsilon_{pr}$ [%]
ICP-1	4)	0.8 <sup>1)</sup>	<< 2.0	1.2	1018	-	0.020
IP-1	3)	> 1.7 <sup>2)</sup>	> 3.2	37.6	1463	216	17.7
	4)	> 1.7 <sup>2)</sup>	< 4.1	36.3	1716	229	16.5
IP-2	3)	> 1.6 <sup>2)</sup>	> 3.2	0.3	-	1.02	44
	4)	> 1.8 <sup>2)</sup>	> 2.9	0.1	-	0.221	33
IP-3	3)	> 1.8 <sup>2)</sup>	> 3.2	13.9	1985	109	26
	4)	1.3 <sup>1)</sup>	< 2.9	12.1	2091	122	22

3) – after 50 thermal cycles  
 4) – after 25 cycles of freezing and thawing  
 Other symbols as in Table 1

The compatibility of the injection materials and concrete substrates was first analyzed using a conventional classification, as given in Table 10.

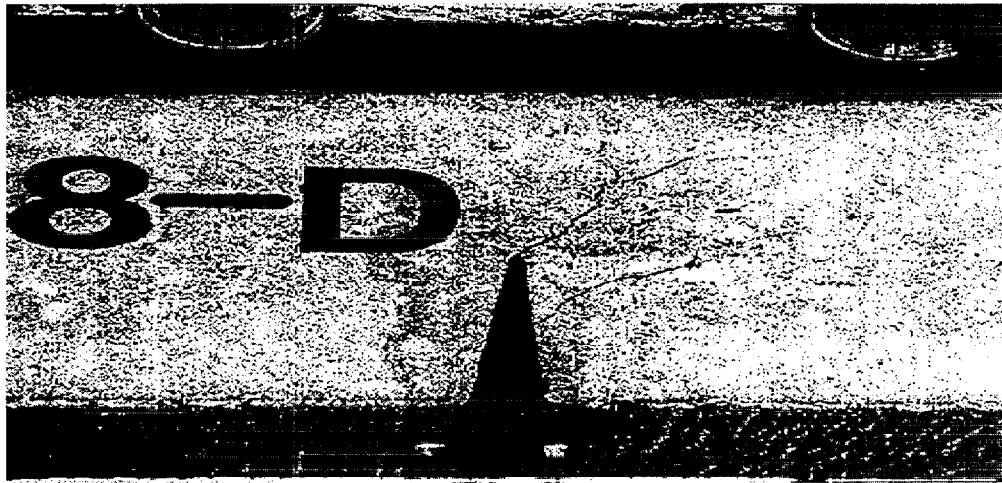
Table 10. Conventional classification of bond effectiveness between injection material and concrete

Assessment	Type of destruction	Description	
Good	A		Cohesive mode of failure; A, B: sufficient adhesion of injection material to concrete on all planes of binding and sufficient tensile strength of injection material
	B		
Insufficient	C		Adhesive mode of failure; C: insufficient adhesion of injection material to concrete on one or two planes of binding D: insufficient tensile strength of injection material
	B		

All the beams repaired with the polyurethane material IP-2 (30 specimens) failed as a result of a crack across the concrete in the area above the place of injection. This is a cohesive mode of failure, as is shown in Fig. 33a. The beams with a crack filled with the epoxy materials IP-1 (9 specimens) and IP-3 (14 specimens), tested at constant temperature, failed beyond the repaired area. An example of an IP-3 specimen is shown in Fig. 33b. The samples repaired using IP-1 (6 specimens), tested after thermal cycling, failed in cross-section through the injected crack, as shown in Fig. 34a. Adhesive failure was found for the beams tested after the freeze-thaw cycles, repaired using IP-1 (6 specimens) and IP-3 (9 specimens), as is demonstrated for an IP-1 specimen in Fig. 34b. The adhesive failure mode was found for all the beams repaired with material ICP-1.

The compatibility space was then determined on the basis of the material control parameters and compared to experimental results. The results of laboratory tests have shown good conformity to the theoretical calculations, as is demonstrated below in Figs. 33-37.

a) injection  
with IP-2  
material



b) injection  
with IP-3  
material

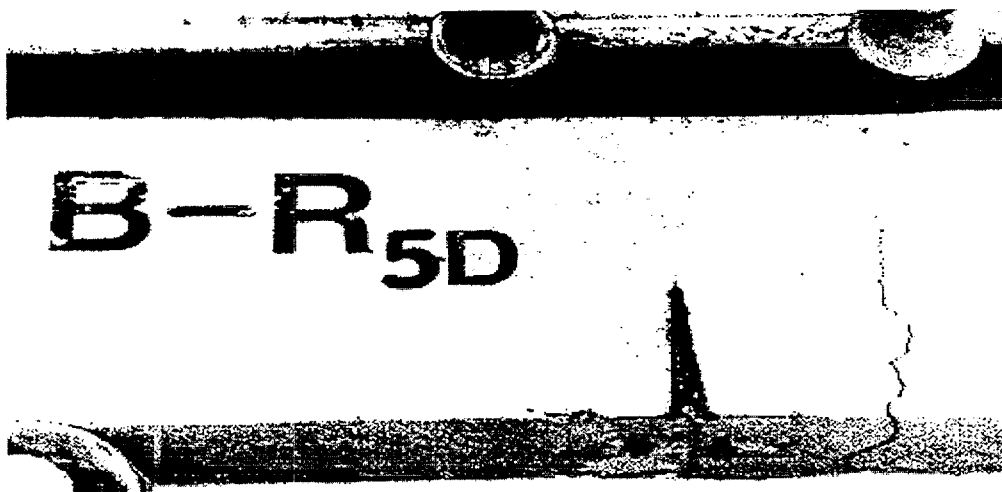


Figure 33. Examples of the failure of the injected beams: tests at constant temperature (IP-2 and IP-3 materials)

Figure 35 shows the compatibility space (three-axis view) for the IP-3 material, tested at constant temperature (a), and for the IP-1 material after thermal cycles. Figure 35a corresponds to Fig. 33b, which showed good compatibility. In Fig. 35a, the point marking the IP-3 material properties lies inside the compatibility space. Figure 35b corresponds to Figs. 34a and 34b. The marked point corresponds to the IP-1 material properties after thermal cycles, and lies outside of the compatibility space, agreeing well with the kind of failures shown in Fig. 34.

The compatibility space for the IP-1 material, under normal conditions, is shown in Fig. 37a. The marked point corresponds to the material properties of the IP-1 material at room temperature, and lies inside the compatibility space. Figure 36 showed good compatibility for this system. It is interesting to note that Fig. 37b shows the same system, but at a higher temperature. In this case, the marked point lies outside the compatibility space, predicting that the failure would be indicative of incompatibility in this case.



a) injection with IP-1 material, tested after 50 thermal cycles

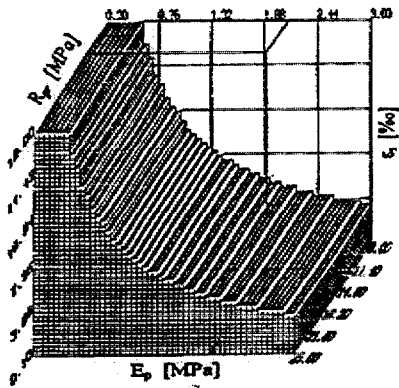


b) injection with IP-1 material, tested after 25 freeze/thaw cycles



Figure 34. Examples of the failure of injected beam (IP-1) material.

a)



b)

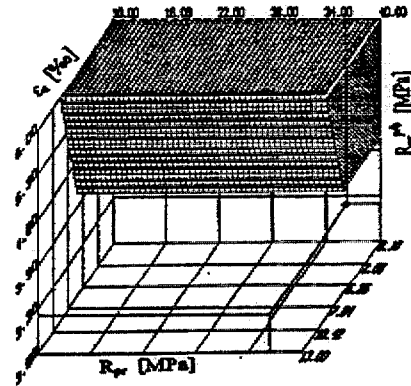


Figure 35. Examples of the compatibility between injection materials and concrete:

- a) The marked point corresponds to the properties of the IP-3 material, tested at the constant temperature. This point is inside the compatibility space.
- b) The marked point corresponds to the properties of the IP-1 material after thermal cycles. This point is outside the compatibility space.

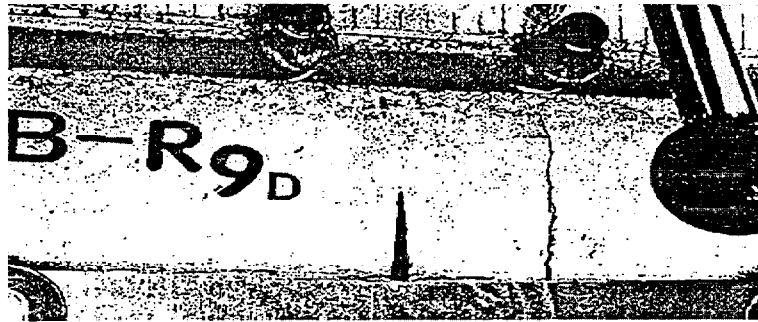


Figure 36. Example of the failure of beam injected with IP-1 material

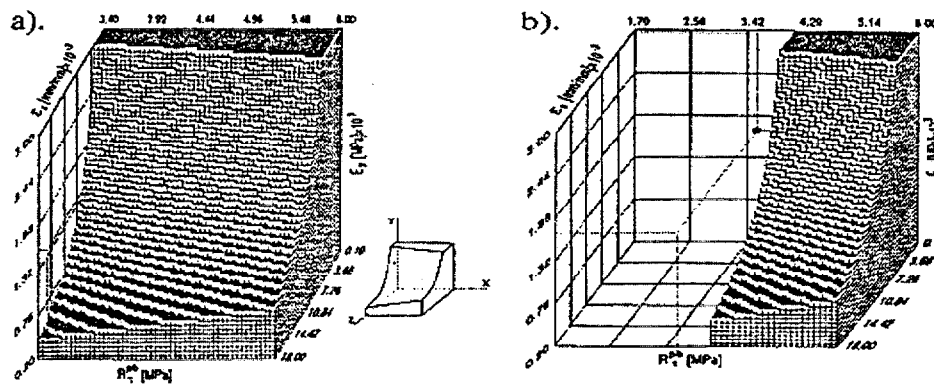


Figure 37. Examples of the compatibility subspace between the IP-1 injection material and concrete substrate under thermal load:

- The marked point corresponds to the properties of the IP-1 material (tests under normal condition). This point is inside the compatibility space.
- The marked point corresponds to the properties of the IP-1 material ( $T = \Delta 40 \text{ }^\circ\text{C}$ ). This point lies outside the compatibility space.

#### 4.3.5 On-site verification of repair material for surface protection of reinforced concrete tank

An actual field case was selected to further test and use the Compatibility program. This case fell under the coating model, but with added inequalities involving corrosion, as the case studied was the selection of a polymer coating for the anti-corrosion protection of a reinforced concrete tank at a sewage plant. A set of 12 technical properties of the coating material, sufficient to define its usability, was selected. The range of their values was determined and listed in Table 11.

The 2 mm-thick polyethylene foil PE-HD was predicted to be sufficient for the surface protection of the concrete in the original project. However, this material solution has been found to be time consuming and expensive. For this reason, a sprayed elastic coating has been proposed as an alternative solution. Three polymer coatings with different technical properties and unit costs were considered: Maxseal Flex, Poly-Pol and Icosit Elastic\*. The concrete substrate of the tank is in the B20 class, with a permissible crack width of  $a_r = 0.2 \text{ mm}$ , and range of service temperature changes  $\Delta T = 30 \text{ }^\circ\text{C}$ .

Table 11. Range of values of the technical properties of coating composites used for surface protection of concrete

Technical features of coating	Unit	Range of values
Interface shear strength, $R_t^{p/b}$	MPa	$R_{bzk} \div 10.0$
Interlayer shear strength of coating, $R_t^{pi/pi+1}$	MPa	2.0 - 15.0
Tensile strength, $R_{pr}$	MPa	2.0 - 60.0
Tensile modulus of elasticity, $E_{pr}$	GPa	0.2 - 20.0
Compressive modulus of elasticity, $E_p$	GPa	0.4 - 30.0
Ultimate tensile strain, $\varepsilon_{pr}$	%	0.1 - 500
Linear shrinkage, $\varepsilon_s$	‰	0.05 - 13.0
Linear expansion coefficient, $\alpha_{tp}$	$K^{-1} \times 10^{-5}$	1 - 12
Thermal conductivity $\lambda_p$	W/ (m K)	0.12 - 1.50
Poisson's coefficient, $\nu_p$	-	0.20 - 0.40
Coating thickness, $h_p$	cm	0.1 - 2.0
Time of effective protection, t	$s \times 10^8$	0 - 3.16

The compatibility space was determined using a set of 12 inequalities. The allowable ranges of the material control parameters within the compatibility space are given in Table 12. In previous figures of a compatibility subspace, only part of the compatibility space, as defined by three of the material control parameters, was shown. Table 12 in principle defines the complete compatibility space.

Table 12. Values of the material control parameters of the elastic coating compatible with the portland cement concrete substrate (B20 class,  $a_r = 0.2 \text{ mm}$ , and  $\Delta T = 30^\circ\text{C}$ ).

$R_{\tau}^{p/b}$	$R_{\tau}^{pi/pi+1}$	$R_{pr}$	$E_{pr}$	$E_p$	$\varepsilon_{pr}$	$\varepsilon_s$	$\alpha_{pr}$	$\lambda_{pr}$	$\nu_{pr}$	$h_p$
MPa	MPa	MPa	GPa	GPa	%	%	$\text{K}^{-1} 10^{-5}$	$\text{W}/(\text{mK})$		cm
2.5-10.0	2.0-15.0	4-60	0.20-0.39	0.40-3.28	15-500	0.005-0.15	1.0-9.8	0.39-1.50	0.20-0.40	0.1-2.0

The technical data from the producer of the selected elastic coatings indicates that all three coatings have properties that fulfill the requirements of compatibility with the given B20 class concrete substrate. On the basis of economy, the cheapest coating has been selected - Maxseal Flex. A compatibility subspace for this material is shown in Fig. 38, essentially showing only three of the ranges listed in Table 12. The cost of this coating is about one third that of the original coating. This coating was then applied on the basis of this computation. After 1 year of service of this coating in the tank, no failure has been observed. The more expensive material solution can be used in the case of more difficult service conditions or concrete substrate with a higher compressive strength (concrete class higher than B20).

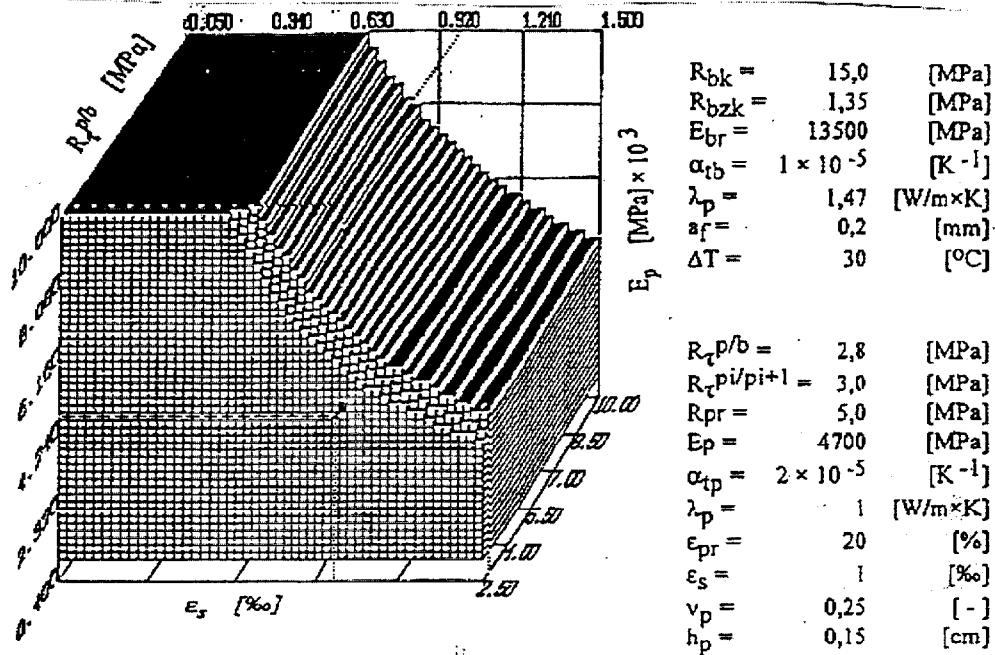


Figure 38. The compatibility space of a polymer repair material coating on portland cement concrete. The marked point represents the properties of Maxseal Flex coating, which lie inside this space.

## 5. COMPATIBILITY COMPUTER SYSTEM (CCS) POSSIBILITIES

On the next pages 16 different compatibility subspaces (four each in Figs.39-42), obtained using the Compatibility Computer System, are presented in order to show how complicated these subspaces can be. Each figure is displayed exactly as in the Compatibility computer program (see Appendix 2 for graphical details). In these figures, a red point indicates where a repair material is incompatible with the substrate, while a green point indicates the material control parameters of the repair material fell inside the compatibility subspace.

One should note that sometimes even a very small change of material properties for the repair material used can change the compatibility conditions in unexpected ways. The opposite situation has also been observed. In some cases, quite a large change of a repair material property surprisingly does not affect the compatibility conditions significantly. Of course, using assumptions like potential crack initiation, crack movement and a gradient of temperature also can change the shape of the compatibility space in various ways.

The numbers accompanying each of the figures in Figs.39-42 give all the properties of the concrete substrate and the repair material. This allows one to analyze the factors that create the transition from compatibility to incompatibility (and vice versa), as well as to observe the compatibility subspaces defined by a choice of three different material parameters (with all the other parameters kept constant). A special computer program window can show those inequalities that are not fulfilled in the incompatibility stage (see Appendix 2: User's Guide). These four color figures illustrate the method for, and the risk of, changing a material control parameter, as well as the effect of these kind of changes on the compatibility of the repair system. This is helpful in using the Compatibility program to predict desirable properties of new materials.

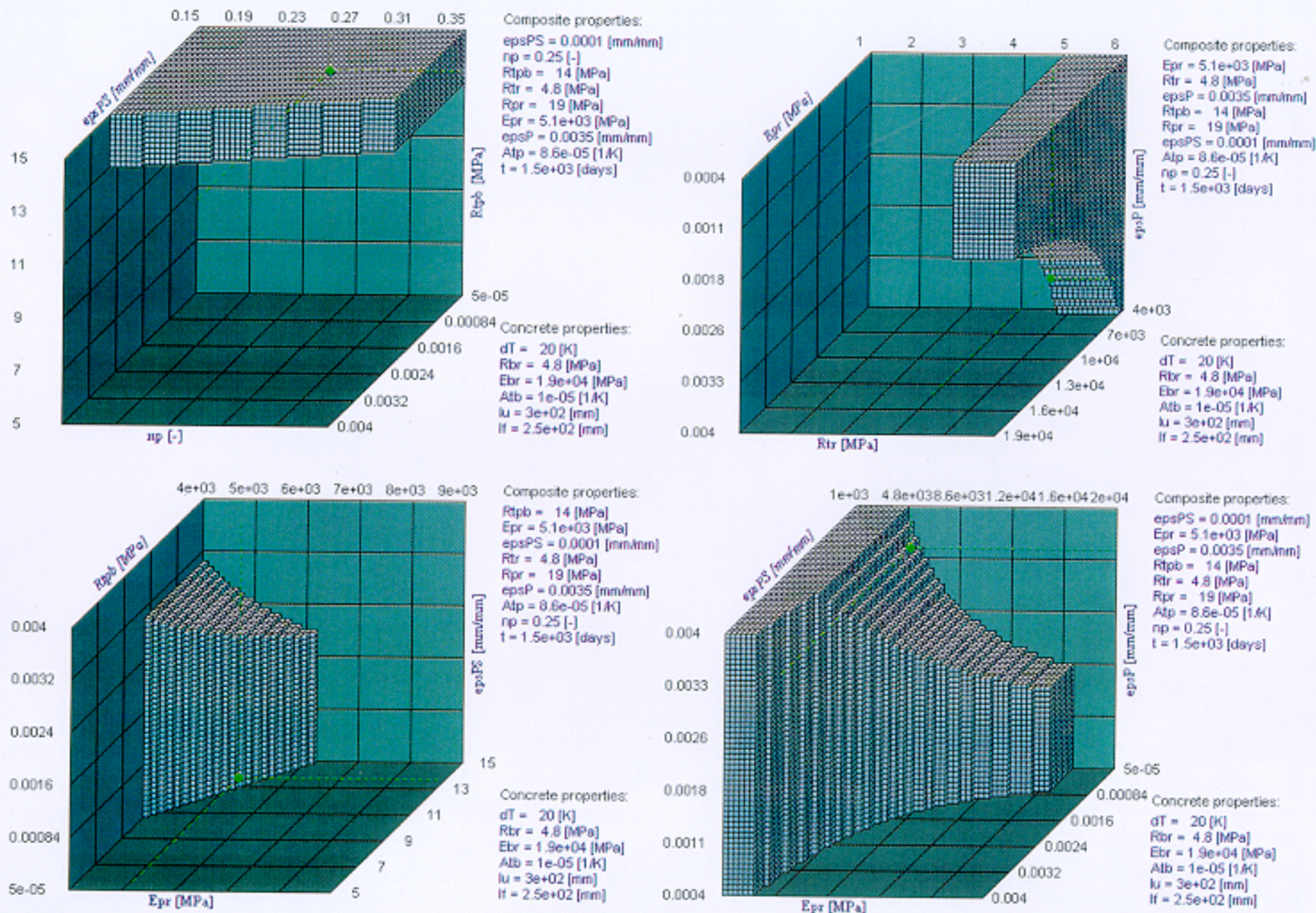
Figure 39 shows compatibility subspaces from the model discussed in Sec. 4.3.2, structural re-surfacing. The substrate was uncracked. The four parts of the figure show the same compatibility subspace, but using different axes each time, with all other variables held constant. The temperature gradient, which is how much the temperature is expected to change during service, was  $\Delta T = 20$  °C. All four graphs show compatibility between the repair material and the substrate. The reader should remember at this point that compatibility depends both on the repair material *and* the substrate properties.

Figure 40 shows compatibility subspaces from the model discussed in Sec. 4.3.2, structural re-surfacing, again for an uncracked substrate. The four parts of the figure show the same compatibility subspace, but using different axes each time, with all other variables held constant. The temperature gradient, which is how much the temperature is expected to change during service, was  $\Delta T = 40$  °C. All four graphs now show, as compared to Fig. 39, *incompatibility* between the repair material and the substrate.

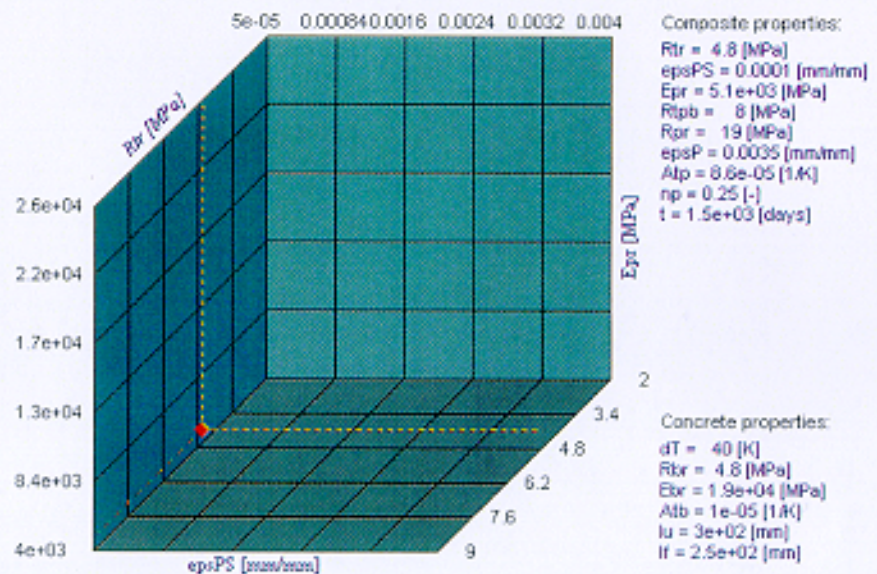
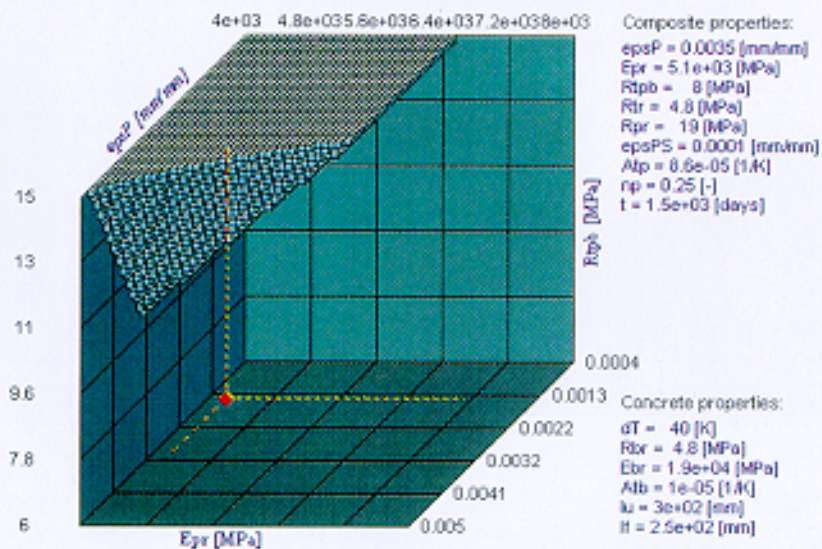
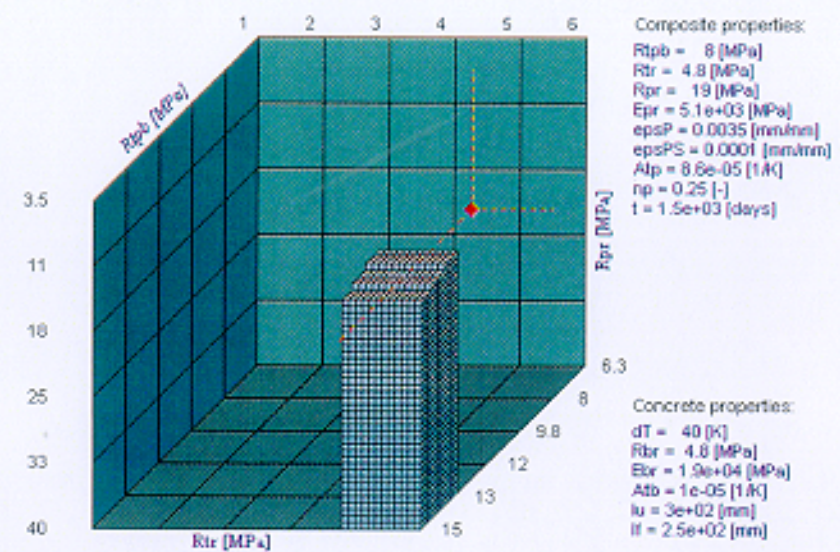
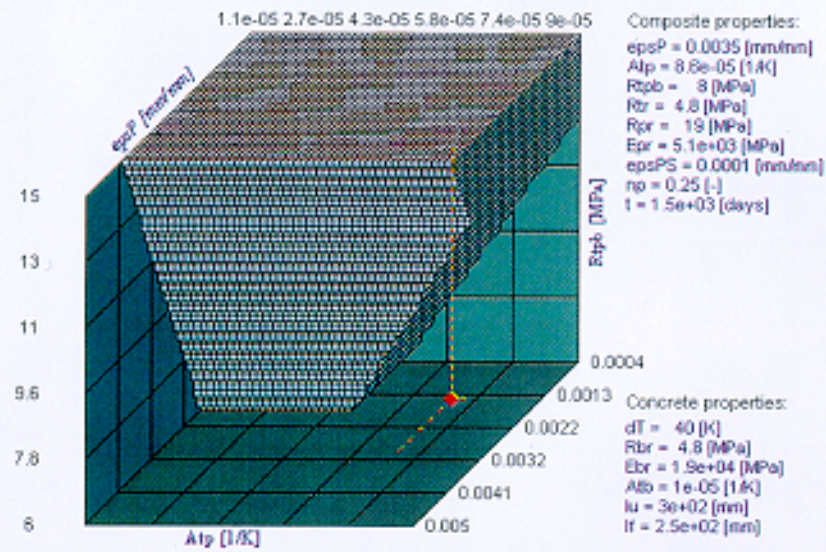
Figure 41 shows compatibility subspaces from the model of a coating on a smooth substrate, discussed in Sec. 4.3.3. The top two graphs are for a cracked concrete substrate, while the bottom pair of graphs are for an uncracked substrate, in which cracks can initiate. From left to right, both the value of  $a_r$  and  $\Delta a_r$ , which are the crack width and the maximum amount the crack width can change, respectively (see Table 1), are increased by a factor of three ( $a_r$  and  $\Delta a_r$  on the graph). Notice the changes in the shape of the subspace, and the change from compatibility to incompatibility in the bottom two graphs.

Figure 42 shows compatibility subspaces from the model of crack injection, discussed in Sec. 4.3.4. The top two graphs are for a maximum change in service temperature of  $\Delta T = 20$  °C, while the bottom pair of graphs have a maximum change in service temperature of  $\Delta T = 80$  °C.

From left to right, some of the properties of the substrate change. Both the tensile strength and tensile elastic modulus decrease from left to right (**E<sub>br</sub>** and **R<sub>br</sub>** on the figure, see Table 1). Notice the change from compatibility to incompatibility, going from top to bottom, as a function of  $\Delta T$ .

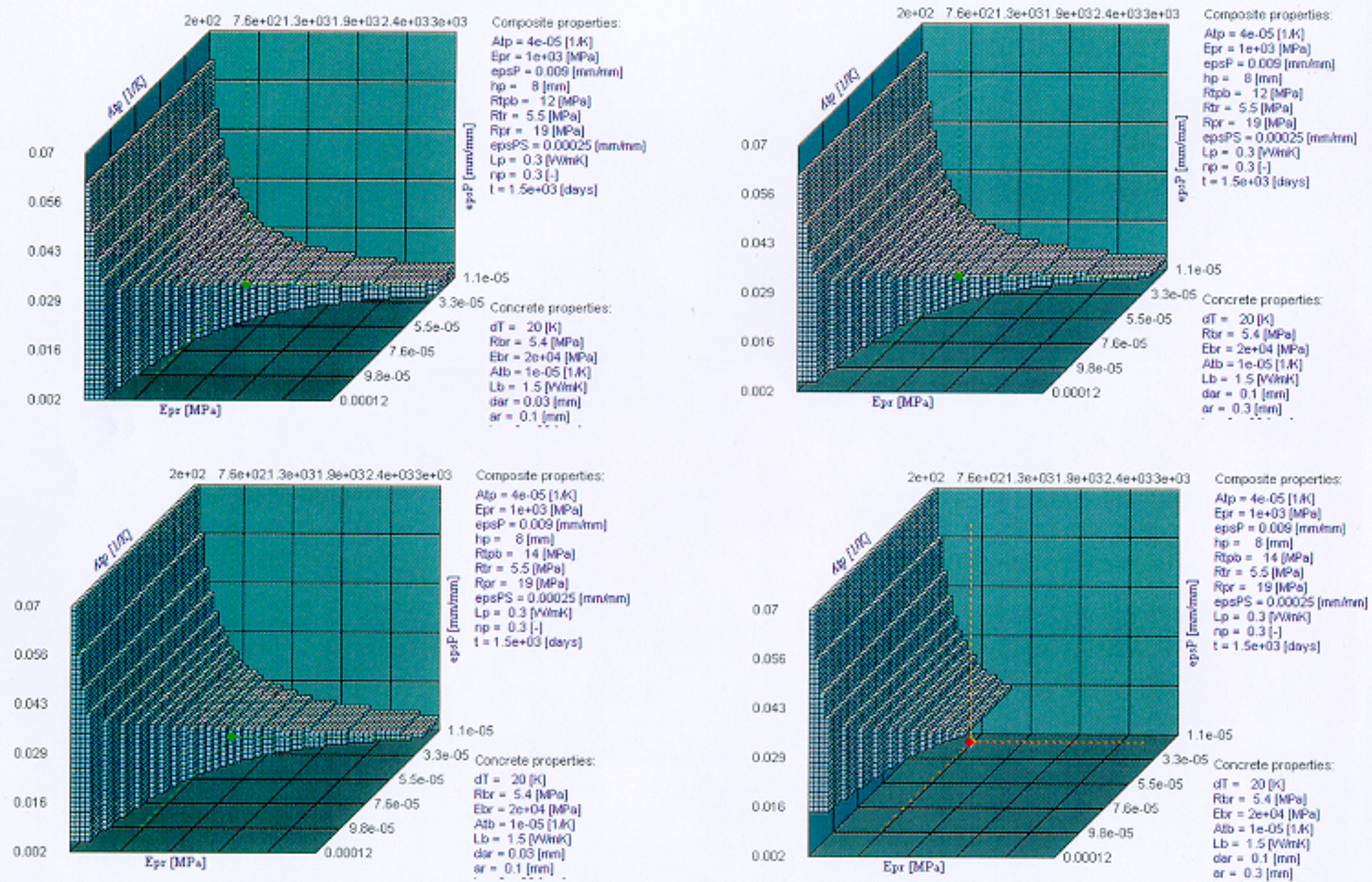


**Figure 39.** Compatibility subspace – structural surfacing of non-cracked substrate - presented using various choices of axes. All graphs show compatibility.



**Figure 40.** Compatibility subspace – structural surfacing of non-cracked substrate. Temperature gradient  $\Delta T = 40$  K. The same compatibility subspace is presented using various choices of axes. All graphs show incompatibility.





**Figure 41.** Compatibility subspace – coating on a concrete substrate (top – cracked concrete, bottom – crack initiation), showing the influence of crack width and crack change (from left to the right and top to bottom).

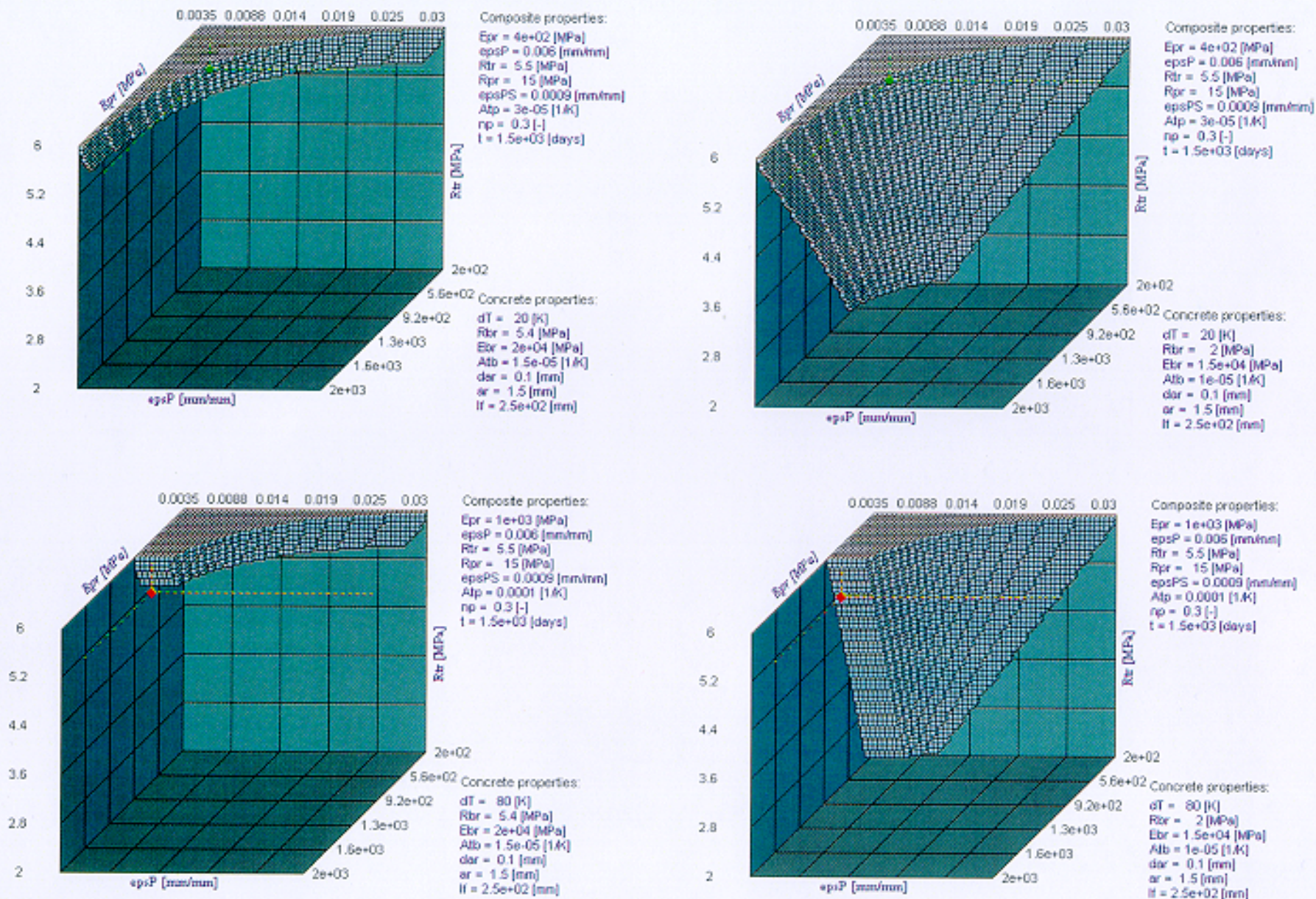


Figure 42. Compatibility subspace ( $\epsilon^P$ ,  $E^P$ , pull-off strength) for polymer crack injection - influence of the temperature gradient:  $\Delta T = 20$  and 80 K. Transition from compatibility to incompatibility.

## 6. SUMMARY AND CONCLUSIONS

The main conclusions from this project are:

- the PC – CC compatibility space exists conceptually,
- the PC – CC compatibility space is possible to obtain for real materials,
- the Compatibility program had been validated and can be used to evaluate the compatibility of repair materials with portland cement concrete substrates.

The following additional conclusions can be formulated on the basis of the results obtained from computer simulation of the compatibility space for polymer composites and portland cement concrete: (1) technical properties of polymer composites do exist that make the determination of the compatibility space for a given polymer composite and portland cement concrete possible, (2) obtaining polymer composites that fulfill the requirements of compatibility with portland cement concrete is difficult but possible in practice, (3) the compatibility space for a given PC-CC system should be treated as a necessary condition rather than a sufficient one, and (4) the analytical selection of polymer composites for repair and/or anti-corrosion protection can be practically used as an introductory evaluation of polymer composite usability in the given application.

## 7. REFERENCES

- [1] L. Czarnecki: The status of polymer concrete. *Concrete International Design and Construction*, 7, 1985, 47-53
- [2] D. Van Gemert, L. Czarnecki, R. Bares: Basis for selection of PC and PCC for concrete repair. *International Journal of Cement Composites and Lightweight Concrete*, 10, 1988, 121-123
- [3] CEN - European Committee for Standardization: Ratified text of the European Prestandard ENV 1504-9:1997: Products and systems for the protection and repair of concrete structures - definitions, requirements, quality control and evaluation of conformity – part 9: General principles for the use of products and systems
- [4] German Committee on Reinforced Concrete: Guidelines for the Protection and repair of Concrete Components, 1992
- [5] J. Wood, E. King, D. Leek: Concrete repair materials for effective structural application. *Construction and Building Materials* 4, 1990, 64-67
- [6] Federal Ministry for Transport: Additional Technical Contract Conditions and Guidelines for the Protection and Repair of Concrete Construction Components ZTV-SIB 90, 1991
- [7] L. Czarnecki, J. Clifton: Polymer concrete; material design and optimization problems. *International Symposium on Concrete Polymer Composites*, Bochum 1991, 63-71
- [8] L. Czarnecki, J. Clifton, Technical Evaluation System (TES) of Concrete-Polymer Composites (TES-C-PC), RILEM Technical Committee 113 International Symposium, Ostende, 1995, 107-113
- [9] J. Clifton, B. Oltikar: Expert System for selecting concrete constituents. *ACI Publication on State-of-the-Art computer applications*, 1986, 1-24
- [10] L. Czarnecki, A. Garbacz, P. Lukowski, and J.R. Clifton, Optimization of polymer concrete composites: Final Report, NIST Internal Report 6361, Gaithersburg, Maryland, USA (1999).
- [11] User's Guide to Optimization Program, Warsaw University of Technology (1999)..
- [12] RILEM TC 124-SRC Draft Recommendation: Repair Strategies for Concrete Structures Damaged by Steel Corrosion. *Materials and Structures* 27, 1994, 415-436
- [13] P. Emmons, A. Vaysburd: Factors affecting the durability of concrete repair: the contractor's viewpoint. *Construction and Building Materials* 1, 1994, 5-16
- [14] L. Czarnecki, J. Clifton: Polymer concrete for repairing. Material optimization and compatibility problems, 3rd Southern African Conference On Polymers in Concrete, Johannesburg 1997, 55-65
- [15] P. Emmons, A. Vaysburd, J. McDonald: A Rational Approach to Durable Concrete Repairs. *Concrete International* 9, 1993, 40-45
- [16] D. O'Coonor, M. Saiidi: Compatibility of polyester-styrene polymer concrete overlays with portland cement concrete bridge decks, *ACI Materials Journal* 90, 1993, 59-68
- [17] Federal Ministry for Transport: Technical Guidelines for Crack Filling in the Concrete, 1993
- [18] L. Czarnecki, P. Lukowski, R. Nejman: The Statistical Evaluation of Epoxy Concrete Heterogeneity. *Cement and Concrete Composites* 6, 1996, 417-428
- [19] L. Czarnecki, A. Garbacz: Evaluation of polymer coating - crack-bridging ability. *International Colloquium „Industrial Floors '95”*, Esslingen 1995, 703-705
- [20] D. Plum: The behavior of polymer materials in concrete repair and factor influencing selection. *The structural Engineer* 68, 1990, 337-346

- [21] D. Plum: Materials - how to select. *Construction Maintenance & Repair* 11-12, 1991, 27-30
- [22] D. Plum: Materials - what to specify. *Construction Maintenance & Repair* 7-8, 1991, 3-7
- [23] D. Plum: Materials - why they fail. *Construction Maintenance & Repair* 9-10, 1991, 3-6
- [24] L. Czarnecki, W. G odkowska, A. Wi ckowska: Model of compatibility of polymer composite-cement concrete (PC-CC) system, Int.Colloquium "Durability of polymer based composite systems for structural application", Brussels 1991, 484-493
- [25] P. Emmons, J. McDonald, and A.Vaysburd, "Some compatibility problems in repair of concrete structures – a fresh look," in the proceedings of the International Colloquium *Material Science and Restoration*, Esslingen 1992, 836-848

## APPENDIX 1: List of publications involved with the project

1. Czarnecki L., Clifton J., Glodkowska W.: Problem of compatibility of polymer mortars and cement concrete system. International Colloquium "Material Science and Restoration", Esslingen, Germany (1992) 964-971
2. Czarnecki L., Glodkowska W.: Polymer mortar - cement concrete system; problem of compatibility, *Proc. of the VII International Congress on Polymers in Concrete – ICPIC'92*, Moscow, Russia (1992) 420-429
3. Czarnecki L., Clifton J.: Technical Evaluation System (TES) of Concrete-Polymer Composites, *Proc. of the Inter. Symposium of the RILEM Technical Committee 113*, Ostenda, Belgium (1995) 107-113
4. Czarnecki L., Glodkowska W.: Approach to the compatibility of polymer composite cement concrete (PC-CC) system., in *Proc. of the International Conference "Progress in Durability Analysis of Composite Systems*, Brussels (1996) 317-323
5. Borjaniec W., Glodkowska W.: Criteria for polymer coating selection at reinforced concrete tanks, *Proc. 10<sup>th</sup> International Conference "Reinforced and post-tensioned concrete silos and tanks*, Kraków, Poland, (1995) 309-316
6. Czarnecki L., Glodkowska W.: Model of compatibility between polymer composites and cement concrete, *Proc. X Conference-Kontra'96: Durability and anticorrosion protection of building structures*, Zakopane, Poland (1996) 69-74
7. Czarnecki L., Glodkowska W.: Polymers concrete as repair means -compatibility problem, *Proc. Int. ICPIC Workshop on "Polymer Concrete for Central Europe*, Bled, Slovenja, (1996) 22-23
8. Czarnecki L., Lukowski P.: Material compliance of epoxy concrete, *Proc. XLI Conference KILiW PAN i PZITB*, Krynica, Poland, (1996) 13-20
9. Czarnecki L.: Materials for repair and restoration of reinforced concrete structures, *Proc. of Symposium: Repairing of high reinforced concrete constructions*, Mildzyzdroje, Poland (1996) 9-23
10. Czarnecki L., Jamrozy Z.: Repair materials for reinforced concrete structures, *Building Materials*, 8 (1996) 2-6
11. Glodkowska W., Romanowski A.: Repair and anticorrosion protection of reinforced concrete chimney, in *Proc. of X Conference-Kontra '96: Durability and anticorrosion protection of building structures*, Zakopane, Poland , (1996) 121-126
12. Czarnecki L., Clifton J.: Polymer concrete for repairing. Material Optimization and compatibility problem, *Proc. of 3<sup>rd</sup> ICPIC Southern African International Conference and Workshop on Polymer in Concrete*, Johannesburg, South Africa (1997)

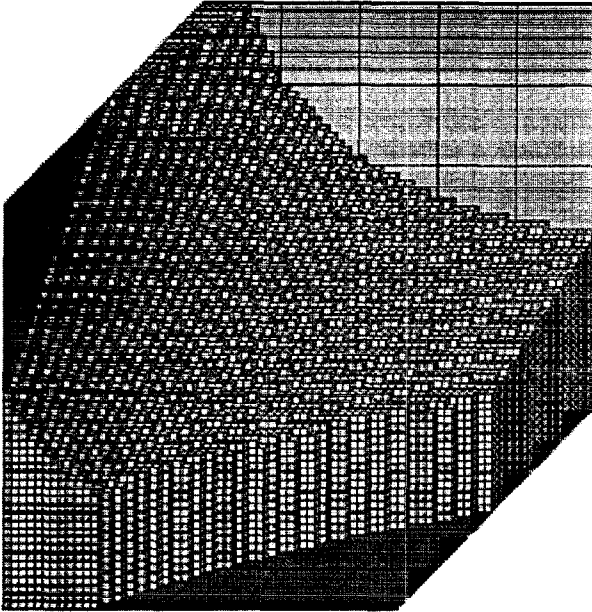
13. Glodkowska W., Piatek Z.: Experimental verification of compatibility between injection material and concrete, *Proc. 2<sup>nd</sup> Conference "Material problems in Civil Engineering-MATBUD'98*, Kraków, Poland, (1998) 133-140
14. Czarnecki L.: Materials for repair and anticorrosion protection of concrete structures, *Building Materials*, 11 (1998) 8-14
15. L.Czarnecki: Materials for repair and strengthening of concrete structures, *Proc. of the XIII Conference Workshop for concrete structure designer*, Ustron, Poland (1998) 21-38
16. L.Czarnecki, A. Wysokowski: Materials for service, repair and strengthening of concrete bridge structures, *Proc. of the VIII Conference Contemporary Methods of Bridges Strengthening and Reconstruction*, Poznan, Poland (1998), 24-44
17. Czarnecki L., Glodkowska W., Piatek Z.: An assessment of usability of injection materials for crack repairs in concrete structures, *2<sup>nd</sup> International Symposium on Adhesion between Polymers and Concrete-ISAP'99*, Dresden (1999)





Appendix 2: User's Guide

USER'S MANUAL



***CES***

*VERSION 1.3*

***COMPATIBILITY COMPUTER SYSTEM***  
***COMPATIBILITY COMPUTER SYSTEM***

---

**MARIA SKLODOWSKA-CURIE US-PL JOINT FUND II**

**Project MEN/NIST-95-234 "Polymer Composites for Repairing  
of Portland Cement Concrete: Compatibility Project"**

**Principal Investigator: Prof. Lech Czarnecki, Ph.D., D.Sc.**

## TABLE OF CONTENTS:

### *ACKNOWLEDGEMENT*

### *SYMBOLS AND ABBREVIATIONS*

#### 1. INTRODUCTION

- 1.1. About software package COMPATIBILITY
- 1.2. Hardware requirements

#### 2. GETTING STARTED

- 2.1. Program installation
- 2.2. Running program
- 2.3. Exiting program

#### 3. PROGRAM UNITS

#### 4. PROGRAM CONFIGURATION

- 4.1. Defining polymer composite properties
  - 4.1.1. Editing parameters
  - 4.1.2. Removing parameters
  - 4.1.3. Adding new parameters
- 4.2. Defining concrete parameters
- 4.3. Defining functions
- 4.4. Defining models
- 4.5. Saving and loading parameters

#### 5. CALCULATION

#### 6. PRESENTATION OF RESULTS

#### 7. HOW TO CONTACT THE AUTHORS

## ACKNOWLEDGEMENT

The COMPATIBILITY package, version 1.3, was developed at Warsaw University of Technology, Poland by Andrzej Garbacz, Wojciech Szychalski and Pawel Lukowski under the scientific leadership of Prof. Lech Czarnecki (Warsaw University of Technology) and Dr James Clifton (National Institute of Standards and Technology, Gaithersburg, MD. In the preliminary stage of the work (DOS version) Andrzej Lenarcik (Kielce Technical University) and Wieslawa Glodkowska (Koszalin Technical University) were also involved. This development was funded by the Maria Sklodowska-Curie US-Polish Joint Fund II: Project MEN/NIST-95-234 "Polymer Composites for Repairing of Portland Cement Concrete: Compatibility Project".

DISCLAIMER: This User's Guide is included as an Appendix to the Final Report of the project "Polymer Composites for Repairing of Portland Cement Concrete: Compatibility Project." This has been done as a convenience for the reader, as the report often refers to the Compatibility program. The User's Guide and Compatibility Program were written solely by the Warsaw University of Technology. The National Institute of Standards and Technology therefore does not endorse or stand behind this program, and does not guarantee or warrant its results in any way.

DISCLAIMER: Certain commercial equipment is identified in this appendix in order to adequately specify the experimental procedure. In no case does such identification imply recommendation or endorsement by the National Institute of Standards and Technology, nor does it imply that the equipment used is necessarily the best available for the purpose.

## SYMBOLS AND ABBREVIATIONS

No.	SYMBOL	SYMBOL IN PROGRAM	UNITS REQUIRED IN THE PROGRAM	PROPERTIES
<b>PROPERTIES OF COMPOSITE (repair material)</b>				
1.	$h_p$	<b>hp</b>	[mm]	Thickness of composite layer
2.	$R^{p/b}$	<b>Rtpb</b>	[MPa]	Adhesion of composite to the substrate; in shear
3.	$R_{pr}^{p/b}$	<b>Rtr</b>	[MPa]	Adhesion of composite to the substrate; pull-off strength
4.	$R_{pr}$	<b>Rpr</b>	[MPa]	Tensile strength
5.	$E_{pr}$	<b>Epr</b>	[MPa]	Modulus of elasticity (in tension)
6.	$\epsilon_{pr}$	<b>epsP</b>	[mm/mm]	Ultimate tension strain
7.	$\epsilon_s$	<b>epsPS</b>	[mm/mm]	Curing shrinkage
8.	$\alpha_p$	<b>Atp</b>	[1/K]	Coefficient of thermal deformation
9.	$\lambda_p$	<b>Lp</b>	[W/m K]	Coefficient of thermal conductivity
10.	$\nu_p$	<b>np</b>	[-]	Poisson coefficient
11.	$D$	<b>D</b>	[cm <sup>2</sup> /s]	Diffusion coefficient
12.	$t$	<b>t</b>	[days]	Time of concrete effective protection by the coating
<b>PROPERTIES OF CONCRETE SUBSTRATE</b>				
13.	$T$	<b>dT</b>	[K]	Temperature gradient
14.	$l_f$	<b>lf</b>	[mm]	Distance between cracks
15.	$R_{br}$	<b>Rbr</b>	[MPa]	Tensile strength
16.	$E_{br}$	<b>Ebr</b>	[MPa]	Modulus of elasticity (in tension)
17.	$\alpha_b$	<b>Atb</b>	[1/K]	Coefficient of thermal deformation
18.	$\lambda_b$	<b>Lb</b>	[W/mK]	Coefficient of thermal conductivity
19.	$a_r$	<b>dar</b>	[mm]	Crack width change
20.	$a_r$	<b>ar</b>	[mm]	Maximum of crack width
21.	$l_u$	<b>lu</b>	[mm]	Bond length

## **1 INTRODUCTION**

Welcome to the COMPATIBILITY COMPUTER SYSTEM – CCS (version 1.3). This system is designed for engineers and scientists interested in material selection for repairing and anticorrosion protection of concrete structures.

### **1.1 About software package COMPATIBILITY**

The software package COMPATIBILITY consists of three parts:

- diskette with the "packed" COMPATIBILITY program, formatted for a standard 3.5" disk, 1.44 MB floppy disk drive,
- registration card and program user licence,
- full documentation.

Before installation please carefully read the licence agreement and user's manual, and make a copy of the distribution disk. Use the original disk only for installation (see section 2.2).

### **1.2. Hardware requirements**

The program was written using the C++ programming language for the Windows 95/98 and NT 4.0 operating systems, and has the following basic hardware requirements:

- IBM PC (or compatible) with Intel Pentium type CPU (a Pentium II CPU with operating at a minimum of 200MHz is recommended),
- 16 MB of RAM memory,
- 5 MB free space on your hard disk,
- monitor and graphics card that ensure a resolution 1024x768 points (color); at lower resolution the main windows are only partially displayed,
- laser or DeskJet printer connected to the LPT1 port.

## **2. GETTING STARTED**

This chapter gives the details of how to install the program on your hard disk, how to run the program, and how to exit the program.

### **2.1. Program installation**

To start work with the COMPATIBILITY COMPUTER SYSTEM, it first should be installed on the hard disk of your computer. There is a special installation program in the COMPATIBILITY package. For installation, a 3.5" disk should be chosen.

To have a successful installation you should do the following operations:

- 1) check your computer to determine if it has the minimum requirements listed above,
- 2) prepare floppy diskette with program and registration card,

- 3) put one of the 3.5" disks into the floppy disk drive (usually A),
- 4) choose the **Run** command from the **Start** menu and select drive **A:** ,
- 5) find **setup.EXE** and click [OK] .

This will start installation of the COMPATIBILITY COMPUTER SYSTEM on the hard disk of your computer in default folder C:\ProgramFiles\Compatibility. Installation will be performed according to standard Windows procedures. Deinstallation of the COMPATIBILITY package can be performed according to standard Windows Procedure as well.

## 2.2. Running program

To run the COMPATIBILITY COMPUTER SYSTEM package choose the **Programs** command from **Start** menu and next **COMPATIBILITY**. The information window (Fig.1) is displayed on the screen after the program is running. The main menu window (Fig.2) of the COMPATIBILITY

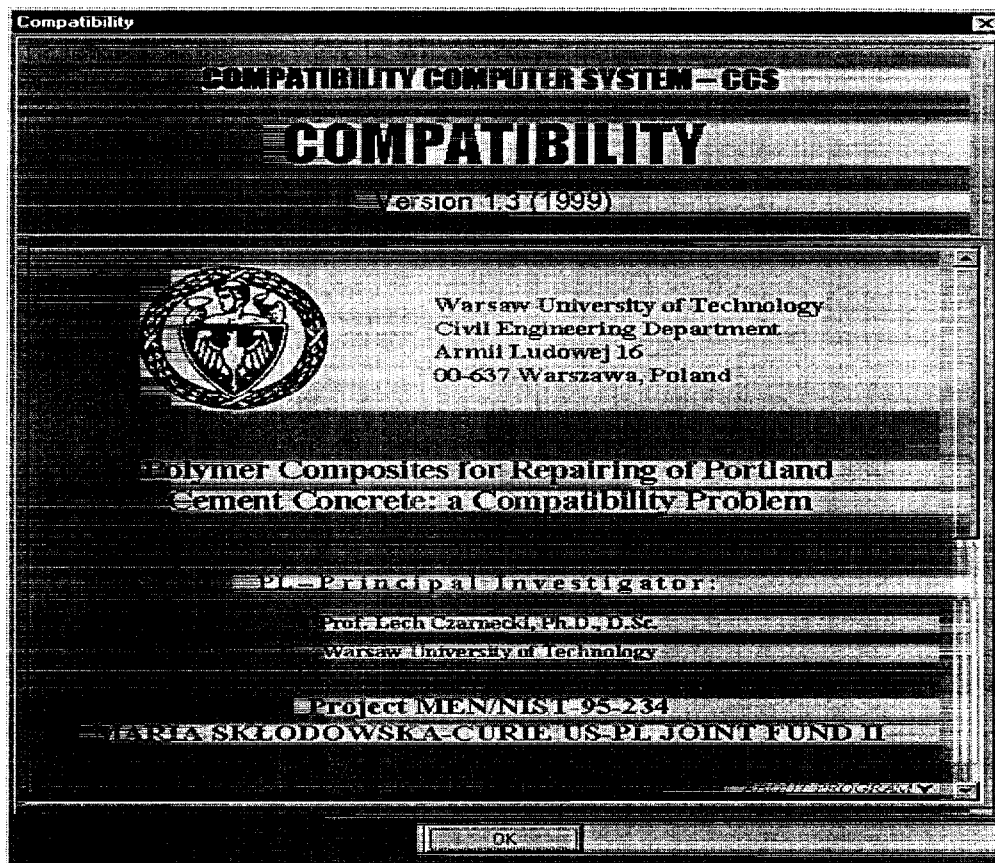


Fig.1. Information window of the COMPATIBILITY program

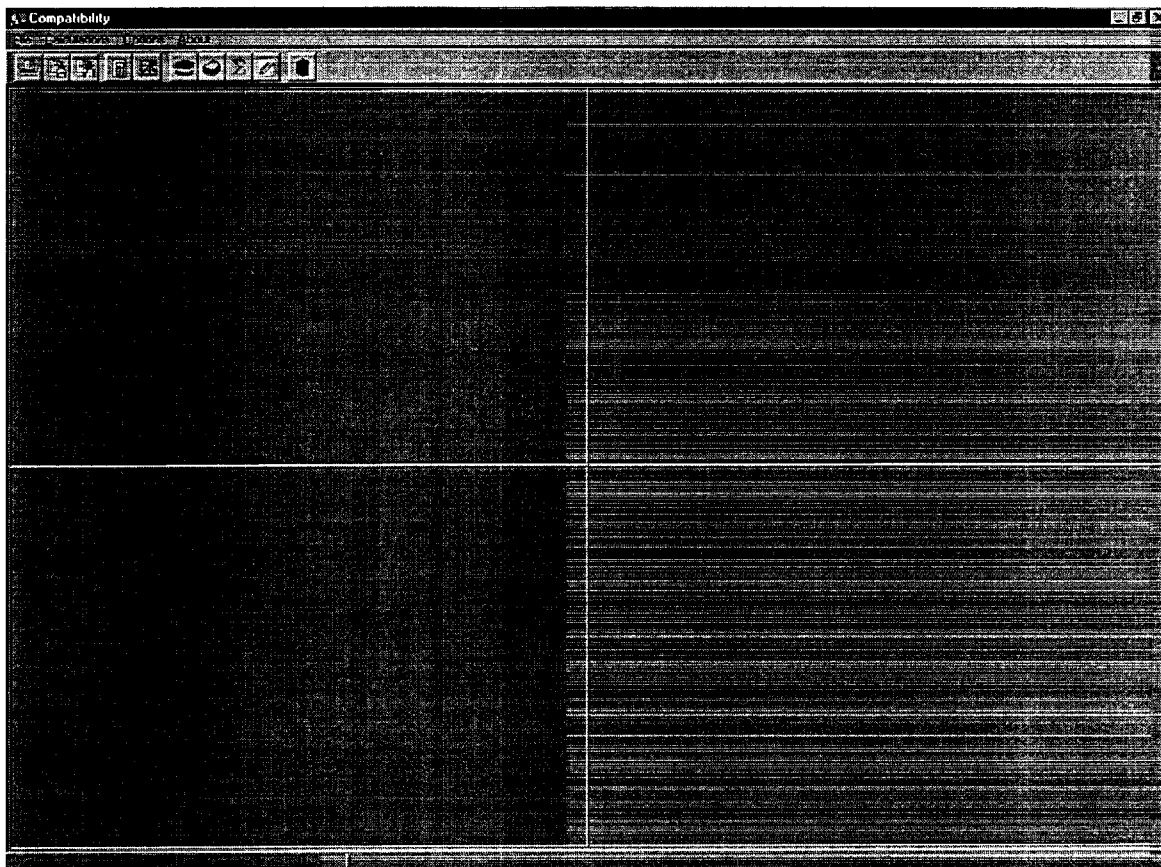


Fig.2. Main menu window after starting program

program appears after pressing the **OK** button. It consists of the typical elements for Windows applications: title bar, menu, toolbar, working area, and status bar.

### 2.3. Exiting program

Correctly exiting The COMPATIBILITY program is very important. **Don't turn off the computer when the program is still running!**. Turning off or restarting the computer with a working program can damage the databases. Correctly exit from the program by choosing the **Exit** command from the **File** menu or by pressing the proper button from the toolbar. This will end the program and return to the operating system. This exit procedure assures the safety of your data.

## 3. PROGRAM UNITS

The COMPATIBILITY COMPUTER SYSTEM package is divided into four main units (see top of Fig.2): **File, Calculations, Options, About** :

- The **File** unit contains the commands involved with printing, copying and saving results of the program (Fig.3)

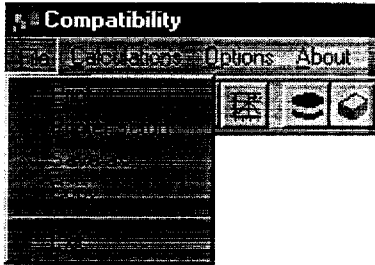


Fig.3. File unit

- Using the **Calculations** unit the compatibility model can be chosen and calculation started (Fig.4)

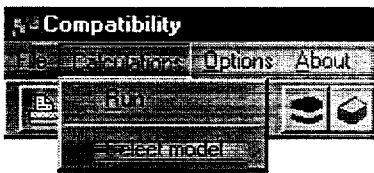


Fig.4. Calculations unit

- The **Options** unit contains subunits for definition of composite and concrete properties, inequalities and compatibility models (Fig.5). The settings can be saved in the default or a selected folder. The settings can also be loaded from the selected folder

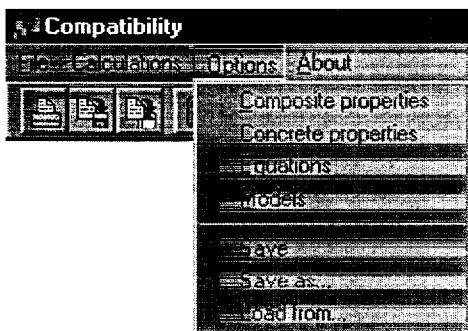


Fig. 5. Options unit



- The **About** unit contains basic information about the program (Fig.6, see also Fig.1)

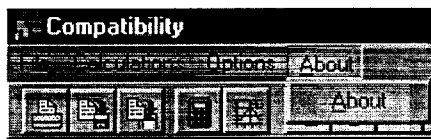












Fig.6. **About** unit

The majority of commands are accessible from the toolbar to make work with the COMPATIBILITY program easier (Table 1)

Table 1. Commands in program menu

Menu command	Icon	Description
<b>File-&gt;Print</b>		Printing of compatibility space
<b>File-&gt;Print setup</b>	None	Selection and configuration of printer
<b>File-&gt;Save as...</b>		Copy of compatibility space diagram to graphic file
<b>File-&gt;Copy</b>		Copy of compatibility space diagram to clipboard
<b>File-&gt;Exit</b>		Exit program
<b>Calculations-&gt;Run</b>		Calculation starting
<b>Calculations-&gt;Select model</b>		Selection and edition of compatibility model
<b>Options-&gt;Composite properties</b>		Definition of composite properties
<b>Options-&gt;Concerte properties</b>		Definition of concrete substrate properties
<b>Options-&gt;Equations</b>		Definition of inequalities
<b>Options-&gt;Models</b>		Definition of compatibility model
<b>Options-&gt;Save</b>	None	Saving of setting files to default directory
<b>Options-&gt;Save to...</b>	None	Saving of settings files to selected directory
<b>Options-&gt;Load from...</b>	None	Load of settings from selected directory
<b>About-&gt;About</b>	None	Information about program

Switching among units of the COMPATIBILITY program can be made at any time from the Main Menu. The program structure permits procedures to be successively performed: from data input, through compatibility space calculation, to graphical presentation of the results.

## 4. PROGRAM CONFIGURATION

Information on the configuration of the COMPATIBILITY COMPUTER SYSTEM is saved in four text files with the *dat* extension: composite.dat, concrete.dat, equations.dat and models.dat. In these files are stored information about the properties of the polymer composite and the portland cement concrete substrates, compatibility conditions, and chosen models. At the start of the program, this information is loaded from the default folder.

### 4.1. Definition of polymer composite properties

For definition of the composite properties, the **Options** menu should be used and then the **Composite** command should be chosen. The suitable button on the toolbar can also be used. A window (Fig.7) appears on the screen. The window consists of the table, in which the composite parameters are defined, and of four buttons: **OK**, **Cancel**, **New** and **Delete**. Immediately after the program is running, the table contains the preliminary defined parameters. The parameters can be modified or removed, and the new ones can be created. The definition of the composites covers:

- symbol
- property
- unit
- min (minimum value of the variability range of the parameter)
- max (maximum value of the variability range of the parameter)
- value (value of the parameter)

Symbol	Property	Unit	Value 1	Value 2	Value 3
tp	thickness of composite layer	[mm]	2	20	15
Rtpb	Adhesion of composite to the substrate, in shear	[MPa]	5.2	15	8.99
Rtr	Adhesion of composite to the substrate; pull-off strength	[MPa]	4.5	6	5.6
Ror	tensile strength	[MPa]	3.5	40	7.18
Epr	modulus of elasticity (in tension)	[MPa]	4000	26000	17681
eps	ultimate tension strain	[mm/mm]	0.0001	0.017	0.00036
epsPS	curing shrinkage	[mm/mm]	6e-05	0.004	0.00054
alpha	Coefficient of thermal deformation	[1/K]	1.1e-05	9e-05	1.6e-05
lambda	coefficient of thermal conductivity	[W/mK]	0.07	0.45	0.3
nu	Poisson coefficient	[-]	0.15	0.35	0.17
D	diffusion coefficient	[mm <sup>2</sup> /s]	5e-10	7e-09	2e-10
	time for concrete effective protection by the coating	[days]	30	3600	1500

Fig.7. Configuration of the polymer composite parameters

### 4.1.1. Editing parameters

The position of the cursor in the table can be selected by clicking, and then the second click switches on the editing mode. The position can also be selected by using the arrow keys. Then by pressing **Enter** the editing mode is switched on.

### 4.1.2. Removing parameters

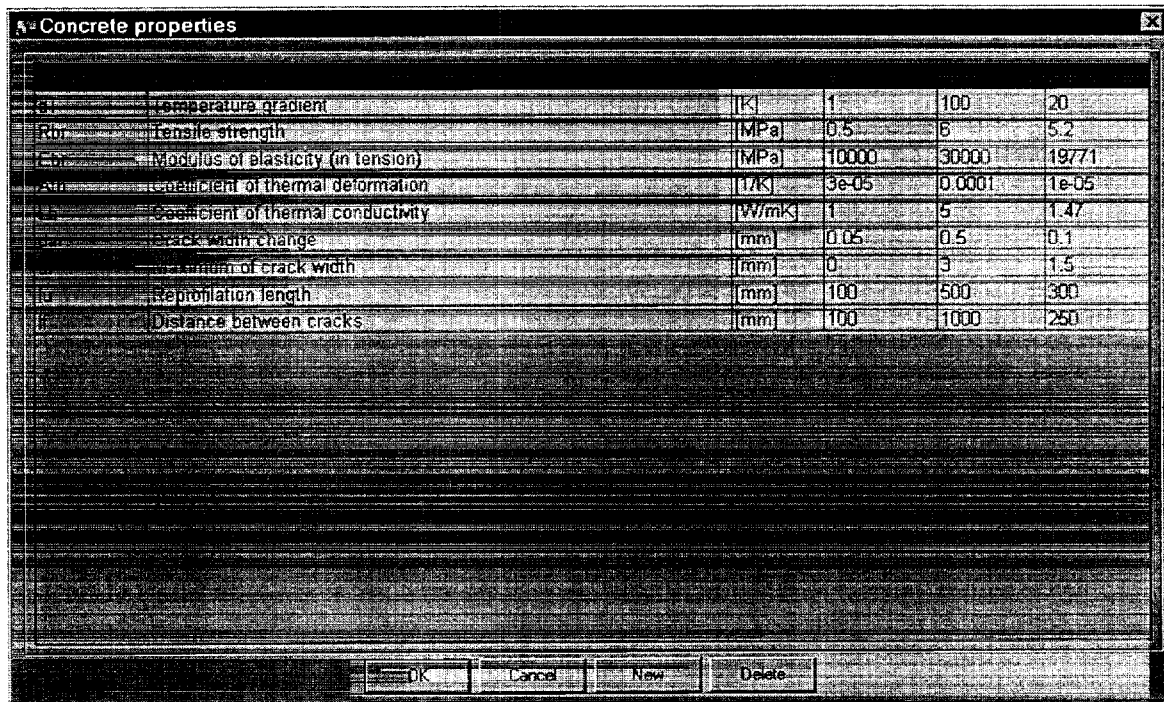
Any parameter can be removed by selecting its value and then pressing the **Delete** button or key.

### 4.1.3. Adding parameters

Adding new parameters can be done by selecting the **New** button. A new row with empty positions appears at the end of the table. Definition of the particular values is then performed in the same way as in editing mode.

## 4.2. Defining of the concrete parameters

For defining the concrete parameters the **Options -> Concrete** command is used. After this command is selected or the suitable button on the toolbar is pressed, the window shown in Fig.8 appears. This window is used similarly to the composite parameters window.



The screenshot shows a dialog box titled "Concrete properties" with a close button (X) in the top right corner. The dialog contains a table with 6 columns: a parameter name, a unit, and three numerical values. At the bottom of the dialog are four buttons: "OK", "Cancel", "New", and "Delete".

Parameter	Unit	Value 1	Value 2	Value 3
Temperature gradient	[K]	1	100	20
Tensile strength	[MPa]	0.5	5	5.2
Modulus of elasticity (in tension)	[MPa]	10000	30000	19771
Coefficient of thermal deformation	[1/K]	3e-05	0.0001	1e-05
Coefficient of thermal conductivity	[W/mK]	1	5	1.47
Crack width change	[mm]	0.05	0.5	0.1
Maximum of crack width	[mm]	0	3	1.5
Reproduction length	[mm]	100	500	300
Distance between cracks	[mm]	100	1000	250

Fig.8. Concrete parameters configuration

### 4.3. Definition of functions

The functions can be defined by choosing the **Options->Equations** command or the suitable button on the toolbar. The window shown in Fig.9 appears. The window consists of the list of available functions and of five buttons: **OK**, **Cancel**, **Edit**, **New** and **Delete**.

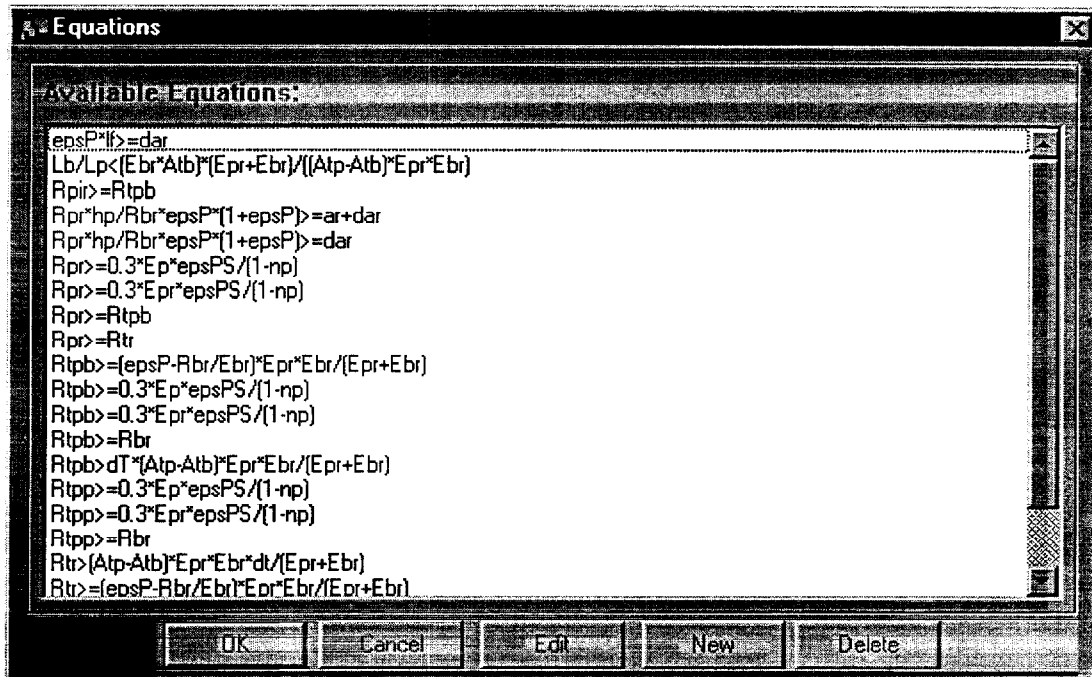


Fig.9. Definition of the functions

For defining a new function, the **New** button should be chosen, and then the function can be input in the special window (Fig.10). The functions can be linear, as well as square root -  $\sqrt{x}$ , exponential -  $\exp(x)$ , or logarithmic -  $\ln(x)$ , where  $x$  is the argument of the function. It is also possible to nest the functions, meaning that the argument  $x$  can be given in function form. The parameters used in the function definition should be in the same form as those used for the definition of the composite and concrete parameters (first column in Fig.7 and Fig.8). The inequalities definition is case sensitive.



Fig.10. New equation editing

Editing an existing function is possible by its selection from the list and using the **Edit** button or by double-clicking on the selected function. A dialogue window with the selected function appears (Fig.11).

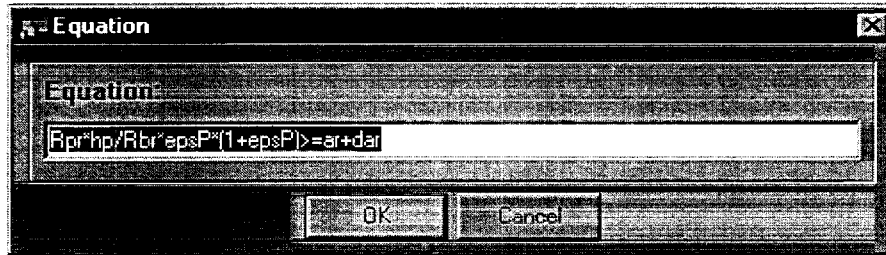


Fig.11. Equation editing

The function can be removed by its selection from the list and using the **Delete** button.

#### 4.4. Defining models

Models can be defined by using the **Options->Models** command. The models definition window (Fig.12) consists of two lists and five buttons: **OK**, **Cancel**, **Edit**, **New** and **Delete**. The left window contains the names of the defined models. The contents of the right window depends on the model chosen (in the left window) and contains the functions attributed to that model. By using the **New**, **Edit** and **Delete** command, new models can be created and the existing ones can be edited or removed.

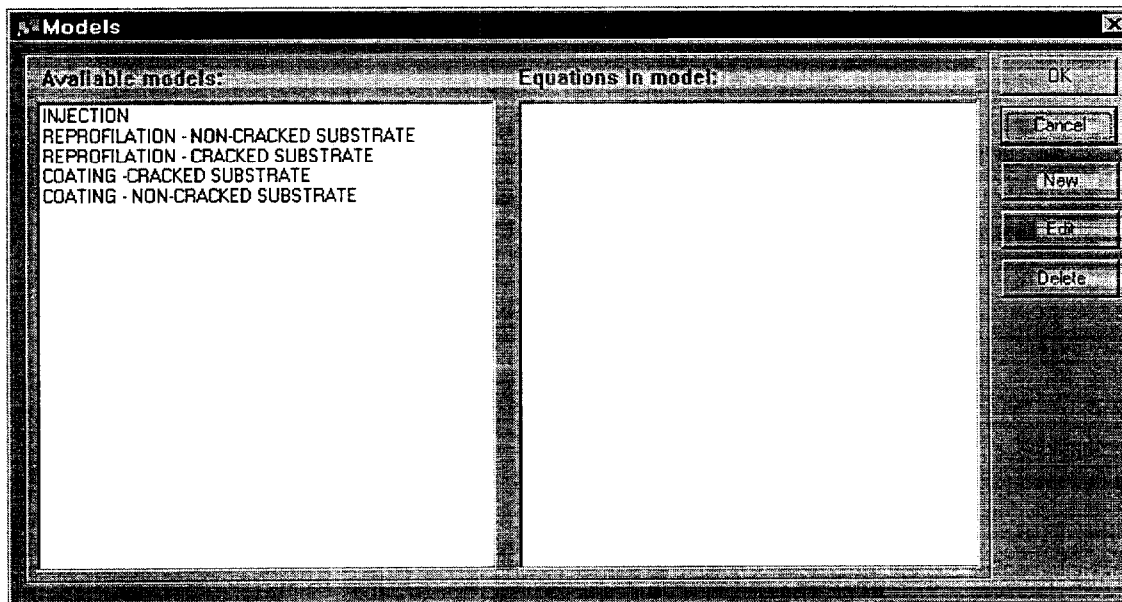


Fig.12. Defining models

Existing and new models can be edited using a separate window (Fig.13). The window consists of the model name, editing position, and two lists. The right list contains the functions attributed to the selected model. In the left window the other available defined functions are listed. The functions can be moved from one window to another by using the buttons placed between the windows.

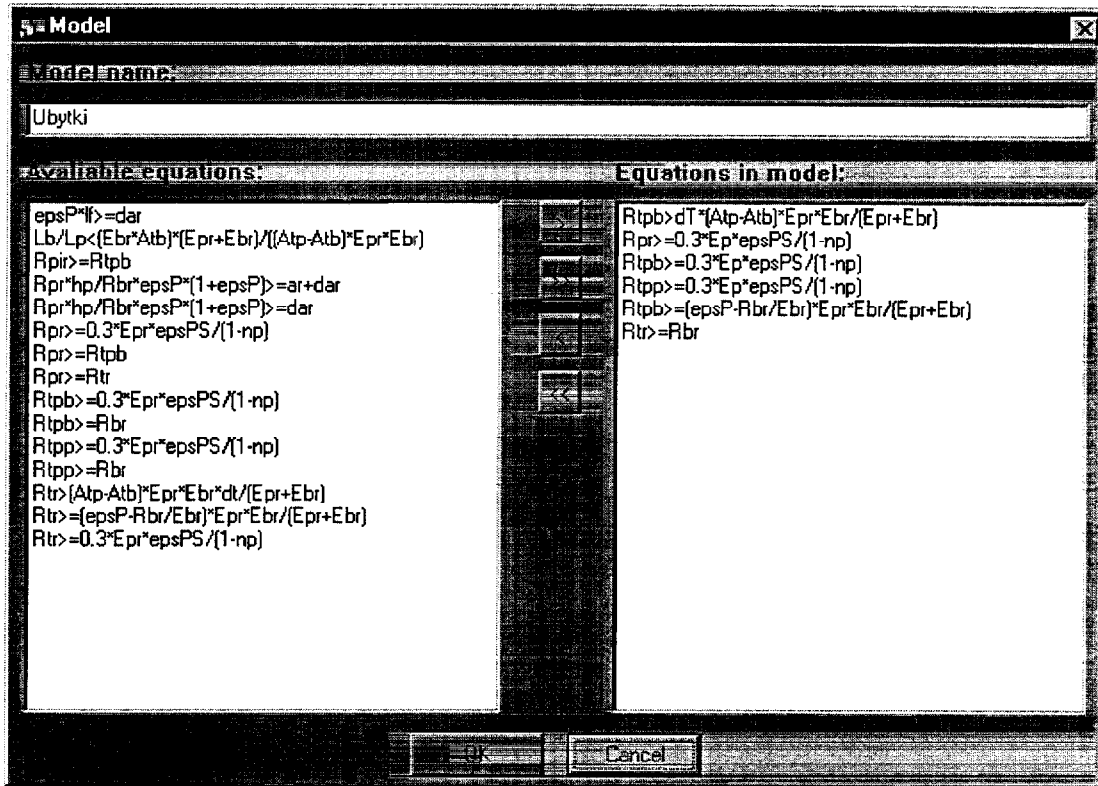


Fig. 13. Model editing

#### 4.5. Saving and loading parameters

The defined parameters can be saved in configuration files, loaded at the start of the program. For this purpose the **Options->Save** command is used. The parameter configuration can also be saved in a folder other than the default one by using the **Options->Save to...** command. After its selection the dialogue window (Fig.14) appears, in which any folder can be selected.

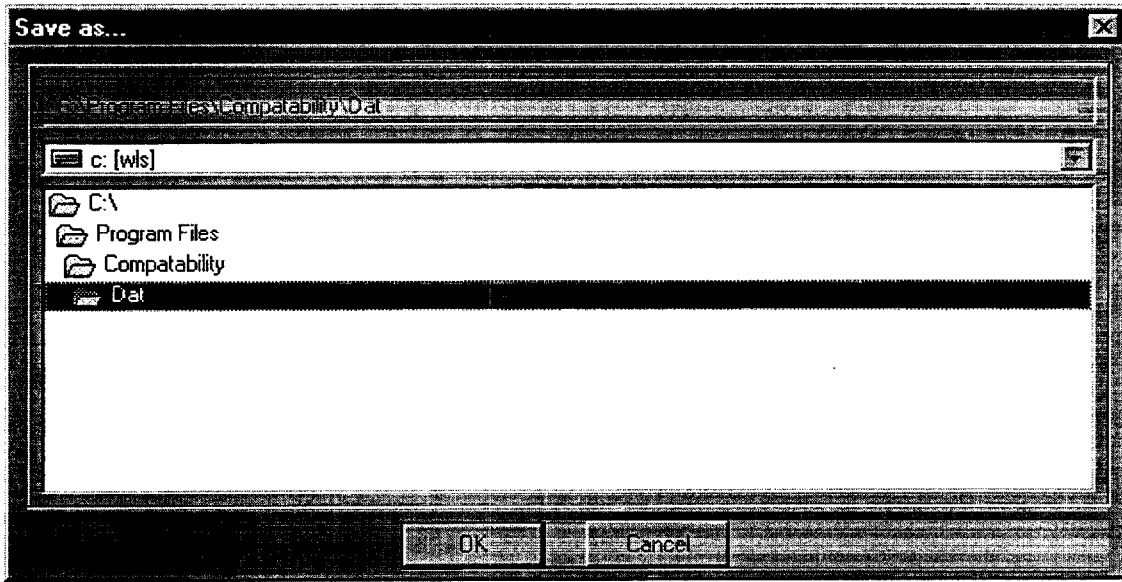


Fig.14. Selection of the folder for saving parameters

The saved configuration can be loaded by using the **Options->Load from...** command. After its selection, the dialogue window (Fig.15) appears.

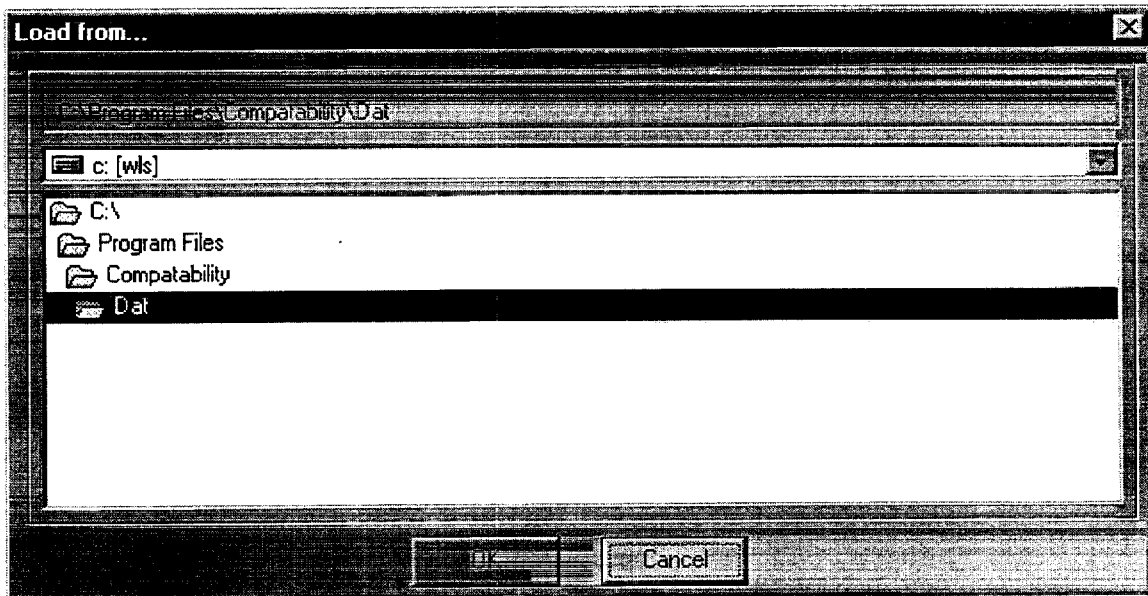


Fig.15. Selection of the folder for loading

## 5. CALCULATION

For performing a calculation, one of the defined models should be chosen by using the **Calculations->Select model** command. After its selection the dialogue window **Select model** appears (Fig.16). At first, the pop-up list **Model** should be used for model selection. Then, the parameters available for the selected model appear in the **Concrete** and **Composite** tables. The values can be changed in the same way as defining the global parameters using the **Options->Concrete properties** and **Options->Composite properties** commands. Next, the axes and their directions should be defined by using the lists and buttons from the **Axis** group. The composite and concrete parameters as well as the axes of the COMPATIBILITY space can be defined separately for four graphs. Any graph can be changed by using the buttons from the **Window selector** group.

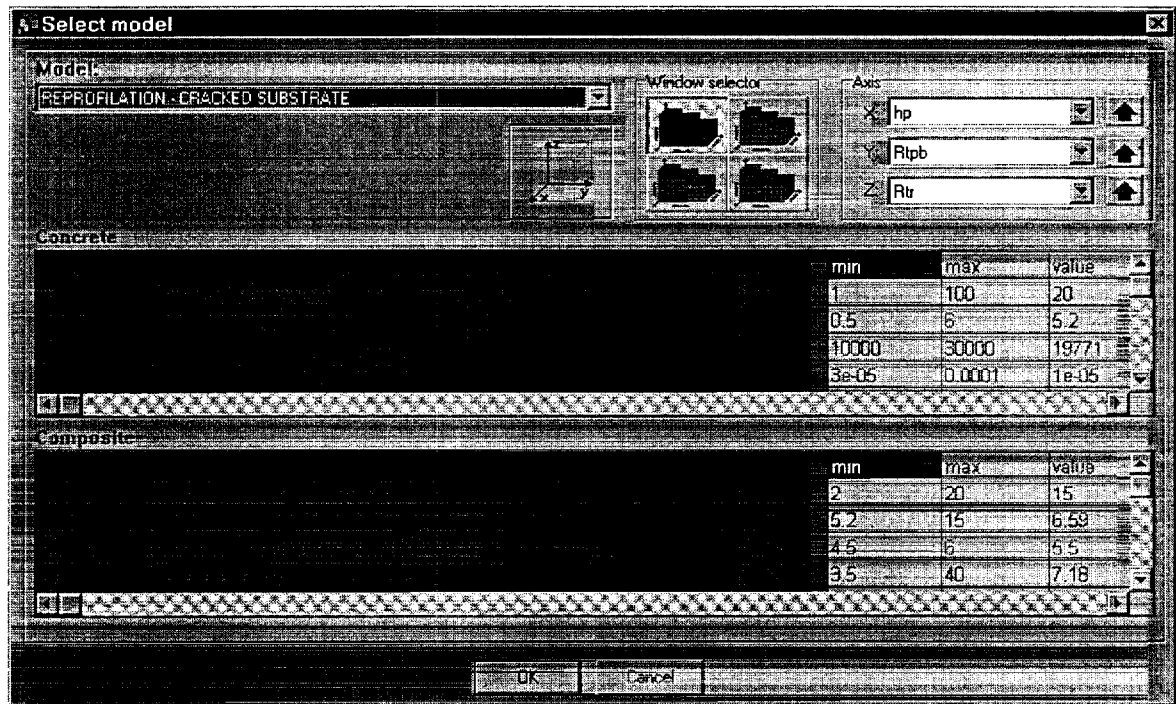


Fig.16. Selection of and editing the model

After all parameters are defined, the configuration should be confirmed by pressing **OK**. A calculation is run by using the **Calculations->Run** command or the suitable button from the toolbar. This command causes the calculation to be performed for all four graphs. The parameters can also be defined and the calculation performed for a selected graph. This can be done by right-clicking on the selected graph and selecting from the sub-menu (Fig.17) the **Model** command. The dialogue window, similar to that used for the model selection, appears; but in this case there



is no possibility for model changing. After confirmation by using the **OK** button, the selected graph is re-calculated.



Fig.17. Sub-menu of the graph

## 6. PRESENTATION OF THE RESULTS

The calculation results can be copied to the clipboard (**File->Copy**), saved in the graphic file in the form of the bitmap (**File->Save as...** (Fig.18)), or printed (**File->Print**). The commands from the **File** group are applied to all four graphs (Fig.19). However, by using the graph sub-menu (right-clicking on the graph, Fig.17), particular commands can be performed for the selected graph. Using this graph sub-menu it is also possible to check (Fig.20), for a selected graph, which requirement is not fulfilled in the case of non-compatibility being found (**Check composite** command).

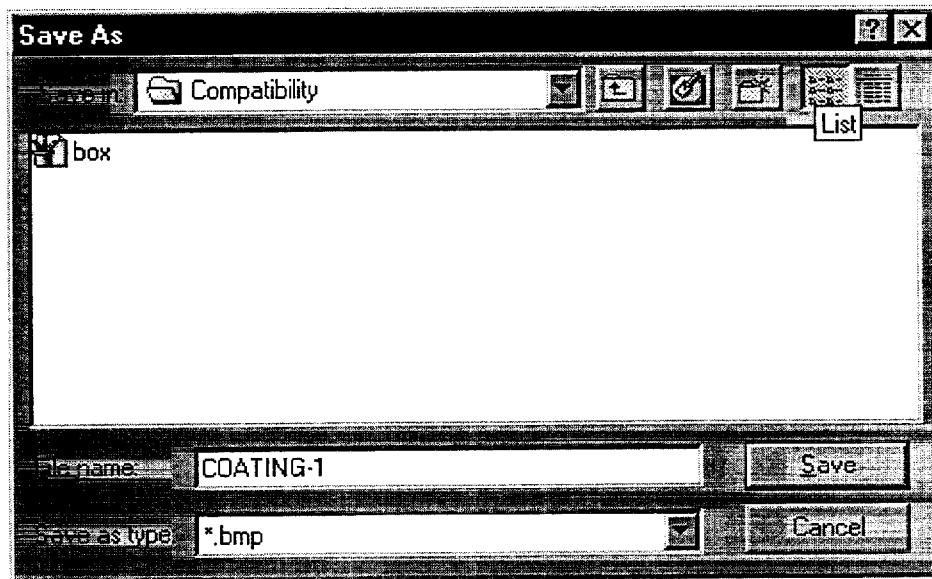


Fig.18. Saving of the figure to disk



Fig.19. Example of presentation of compatibility subspace for different coordinate systems



Fig.20. Example of non-compatibility subspaces. In special window (right bottom) is shown which inequality is unfulfilled

## **7. HOW TO CONTACT THE AUTHORS**

If, after reading this guide or using the COMPATIBILITY computer system, version 1.3, you have any questions, comments, or suggestions, you should contact:

Prof. Lech Czarnecki  
Institute of Technology and Organization of Building Production  
Warsaw University of Technology  
00-637 Warsaw, Al. Armii Ludowej 16, Poland  
tel. (+4822) 825-76-37, fax.: (+4822) 825-74-15  
e-mail: [lcz@omk.il.pw.edu.pl](mailto:lcz@omk.il.pw.edu.pl)