

**An Efficient Large Eddy Simulation Algorithm for
Computational Wind Engineering: Application to
Surface Pressure Computations on a Single Building**

**Ronald G. Rehm, Kevin B. McGrattan, Howard R. Baum
and Emil Simiu**

**Building and Fire Research Laboratory
Gaithersburg, MD 20899**



**United States Department of Commerce
Technology Administration
National Institute of Standards and Technology**

NISTIR 6371

**An Efficient Large Eddy Simulation Algorithm for
Computational Wind Engineering: Application to
Surface Pressure Computations on a Single Building**

**Ronald G. Rehm, Kevin B. McGrattan, Howard R. Baum
and Emil Simiu**

**Building and Fire Research Laboratory
Gaithersburg, MD 20899**

August, 1999



U.S. Department of Commerce
William M. Daley, *Secretary*
Technology Administration
Gary R. Bachula, *Acting Under Secretary for Technology*
National Institute of Standards and Technology
Raymond G. Kammer, *Director*

CONTENTS

ABSTRACT	1
1. Introduction	1
2. The Model and LES Methodology	3
3. Comparison with Measurement of Baines	5
3.1 Flow Over a Tall Building	6
3.1.1 Uniform Flow	9
3.1.2 Shear Flow	9
3.2 Flow Over A Cubical Building	13
3.2.1 Uniform Flow	14
3.2.2 Shear Flow	14
4. Comparison with Computations of Shah & Ferziger	17
5. Comparison with AIJ Reports Results	21
6. Summary and Conclusions	24

An Efficient Large Eddy Simulation Algorithm for Computational Wind Engineering: Application to Surface Pressure Computations on a Single Building

R.G. Rehm, K.B. McGrattan, H.R. Baum & E. Simiu
Building and Fire Research Laboratory
National Institute of Standards and Technology
Gaithersburg, MD 28099

Abstract

An efficient large eddy simulation algorithm is used to compute mean surface pressure distributions on an isolated building of various rectangular shapes. Two incoming mean wind profiles are considered in these computations, one uniform with height and the other increasing as a power law with height. The second profile accounts for flow retardation due to friction from the surface of the earth; in neither case are turbulent fluctuations included in the work. Mean pressure distributions are computed for a tall building, a cubical building and a flat building. These computational results are compared with wind tunnel measurements and computations performed by other investigators. The agreement in most cases is very good with differences of approximately twenty percent. Whereas the computations reported by the other investigators require supercomputers, most of our computations have been performed on a modern workstation and can be carried out routinely with computation times representing a small fraction of those required by supercomputing.

1 Introduction

Computational wind engineering (CWE) is a developing area of research; it is part of the rapidly growing area of computational sciences. The revolutionary increase in computer power coupled with the evolution of algorithms for computational fluid dynamics has created an opportunity for the computational exploration of wind effects on structures. The recent publication of the Proceedings of the 2nd International Symposium on Computational Wind Engineering (CWE 96) highlights both the status of CWE and its rapid development [1]. In particular, the state of the art is portrayed in the keynote presentations by Murakami [2], Shah and Ferziger [3], Pielke and Nicholls [4], and Stathopoulos [5].

All demonstrate the capability of the methods by comparison either with wind-tunnel results or with full-scale measurements. The latter are difficult to obtain, may be unrepeatable and usually have large uncertainties. Wind-tunnel measurements, on the other hand, are

controlled and more reproducible, and are commonly used for CWE assessment and validations. Wind-tunnel tests conducted by Flachsbart at the Goettingen Aerodynamics Research Establishment in 1932 were the first to point out the differences between aerodynamic pressures on building models tested in uniform, smooth flow on the one hand and in shear flow on the other; typical results are reproduced in *Wind Effects on Structures*, [6] p. 173. Testing in shear flow, simulating – with various degrees of success – the atmospheric boundary layer flow, became routine in engineering practice only in the 1960’s. At that time Baines [7] reported a classic set of measurements of mean pressures in a wind tunnel under both smooth uniform flow and shear flow. Recently, in a systematic joint effort under the aegis of the Architectural Institute of Japan (AIJ) [8], computational results obtained by three universities and nine industrial institutes were compared with wind tunnel measurements conducted under test conditions specified in careful detail.

Shear flow is associated with mechanical turbulence, which has been shown experimentally to influence the flow-body interaction. The magnitude of this influence varies depending upon the situation at hand. For example, consider a building located in a city center. To simulate correctly wind effects on that building it is necessary to model not only the building itself but also the buildings surrounding it. The signature turbulence of those buildings is likely to dominate the incoming flow turbulence, that is, the turbulence in the undisturbed flow at a sufficiently large distance upwind of the set of buildings of interest (the signature turbulence of a body is the turbulence generated by the interaction of the incoming flow with that body). The simulation of the incoming flow turbulence may then be of secondary importance. Nevertheless, there are many instances where the incoming flow turbulence can play a significant role.

There are essentially two approaches for accounting for such turbulence in numerical simulations. One approach is to make use of assumed constitutive relations describing the turbulence structure within a flow (e.g., mixing length relations). A problem with this approach is that the uncertainties inherent in the use of the constitutive relations are generally unknown – the magnitude of these uncertainties, which can be considerable, can differ from case to case in a manner that is difficult to predict. A second approach is to simulate the turbulence in the incoming flow by prescribing appropriate time-dependent boundary conditions, and to allow for the correct representation of smaller scale turbulence features and effects by increasing the resolution used in the computations, that is, by decreasing the size of the grid elements on which the numerical calculations are based. We have chosen this second approach. However, at this time the volume of calculations required to account for small-scale turbulence effects exceeds the capacity of hardware routinely used in CWE.

The purpose of this paper is to present results obtained by using an efficient Large Eddy Simulation (LES) methodology described in detail in [9] - [12]. The methodology was developed and used for the description of gas phase combustion and convection processes in fires, where buoyancy is fundamental. In contrast, in most wind engineering applications wind speeds are high, so that mechanical turbulence dominates thermal effects, and buoyancy effects are relatively small. We present results of calculations performed for building models for which wind tunnel measurements were reported in [3], [8] and [7]. We point out that, as will be shown in the body of the paper, the hallmark of our methodology is its superior numerical efficiency. Nevertheless, for the reasons discussed in the preceding paragraph, we will assume in the calculations that the incoming flow - whether uniform flow or shear flow

– is turbulence-free. In addition, signature turbulence effects are accounted for only to the extent implicit in the size of the grid. Our methodology is, however, fully consistent with more stringent turbulence simulation requirements; the only obstacle, which we presume is only temporary, is the memory capacity and computational speed of the type of hardware we use.

In Section 2, we state the Navier-Stokes equations in a form suitable for computation and describe the Large Eddy Simulation (LES) methodology which we use in our computations. In Section 3, for both a slender tall building and a cubic building, we compare mean pressures measured in the wind tunnel by Baines [7] and obtained by our computational methodology. We show that our calculations: (1) reproduce correctly the qualitative differences between mean pressures induced by smooth uniform flow on the one hand and shear flow on the other, and (2) that, in spite of neglecting incoming turbulence effects, the quantitative agreement between measurements and calculations is good, varying by about twenty percent.

In Section 4, for flow over a cubical building model, we compare mean velocity fields calculated by Shah and Ferziger [3] and by our methodology. In Section 5, we describe the results obtained by a working group of the Architectural Institute of Japan [8] using a flat-building model, and present comparisons of their wind tunnel measurements and CFD calculations of mean pressure distributions with ours. In Section 6, we discuss these results and present our conclusions.

2 The Model and LES Methodology

The flow is governed by the incompressible Navier-Stokes equations:

$$\nabla \cdot \vec{v} = 0 \tag{1}$$

$$\frac{\partial \vec{v}}{\partial t} + \nabla(v^2/2) - \vec{v} \times \vec{\omega} + \nabla p = \frac{1}{Re} \nabla^2 \vec{v} \tag{2}$$

The first of these equations is a statement of the conservation of mass, which for an incompressible fluid is equivalent to conservation of volume. The second, vector equation is the statement of conservation of momentum. Here, all symbols have their usual fluid dynamical meaning: \vec{v} is velocity, p is pressure and $\vec{\omega} = \nabla \times \vec{v}$ is the vorticity. In addition, t is time and ∇ is the spatial gradient, divergence or curl operator. All quantities have been made dimensionless, the lengths relative to a length scale L determined by the height of the target “building,” the velocity relative to a scale V_0 determined by the incoming flow, the pressure relative to the dynamic pressure ($\rho V_0^2/2$) and the time relative to the length scale and the velocity scale. Here, Re is the Reynolds number, $V_0 L/\nu$, where ν is the kinematic viscosity. For the computations presented here, we have chosen a small constant effective kinematic viscosity ν which is just large enough to dissipate velocity variations at the resolution limits of the calculation. This leads to an effective Reynolds number in the reported computations which allows direct simulation of convective motion over a spatial range of about two orders of magnitude for the three-dimensional calculations.

To obtain the pressure, we take the divergence of the momentum equation rewritten as

follows:

$$\frac{\partial \mathbf{u}}{\partial t} + \mathbf{F} + \nabla \mathcal{H} = 0 \quad (3)$$

where \mathcal{H} is defined to be the total pressure divided by ρ_∞ :

$$\mathcal{H} = \frac{|\mathbf{u}|^2}{2} + \frac{\tilde{p}}{\rho_\infty} \quad (4)$$

and where

$$\mathbf{F} = \nabla \cdot \left(\vec{v} \times \vec{\omega} - \nabla(v^2/2) + \frac{1}{Re} \nabla^2 \vec{v} \right)$$

All the convective and diffusive terms have been incorporated in the term \mathbf{F} . The resulting equation for \mathcal{H} is an elliptic partial differential equation

$$\nabla^2 \mathcal{H} = -\nabla \cdot \mathbf{F} \quad (5)$$

The linear algebraic system arising from the discretization of Eq. (5) has constant coefficients and can be solved to machine accuracy by a fast, direct (*i.e.* non-iterative) method that utilizes fast Fourier transforms [14]. No-flux boundary conditions (BCs) are specified by asserting that along the normal n

$$\frac{\partial \mathcal{H}}{\partial n} = -F_n \quad (6)$$

at solid walls, where F_n is the normal component of \mathbf{F} at the wall. This equation asserts that the normal component of velocity at the wall does not change with time, and indeed remains zero assuming the flow velocity is initially zero. At open external boundaries it is assumed that the perturbation pressure is zero, but there are numerous other strategies for prescribing open boundary conditions that will not be discussed here [13].

Direct Poisson solvers are most efficient if the domain is a rectangular region, and the no-flux condition (6) is simple to prescribe at external boundaries. However, internal obstructions may be included in the overall domain as masked grid cells, but the no-flux condition (6) cannot be directly prescribed at the boundaries of these blocked cells due to consistency issues. However, it is possible to exploit the relatively small changes in the pressure from one time step to the next to enforce the no-flux condition. At the start of a time step, the components of the convection/diffusion term \mathbf{F} are computed at all cell faces that do not correspond to walls. Then, at those cell faces that do, set

$$F_n = -\frac{\partial \mathcal{H}^*}{\partial n} + \beta u_n \quad (7)$$

where F_n is the normal component of \mathbf{F} at the wall, and β is a relaxation factor empirically determined to be about 0.8 divided by the time step. The asterisk indicates the most recent value of the pressure. Obviously, the pressure at this particular time step is not known until the Poisson equation is solved. Equation (7) asserts that following the solution of the Poisson equation for the pressure, the normal component of velocity u_n will be driven closer to zero according to

$$\frac{\partial u_n}{\partial t} \approx -\beta u_n \quad (8)$$

This is approximate because the true value of the velocity time derivative depends on the solution of the pressure equation, but since the most recent estimate of pressure is used, the approximation is very good. Also, even though there are small errors in normal velocity at solid surfaces, the divergence of each blocked cell remains exactly zero for the duration of the calculation, and the consistency condition (5) ensures global mass conservation. In other words, the total flux into a given obstacle is always identically zero, and the error in normal velocity is usually at least 3 or 4 orders of magnitude smaller than the characteristic flow velocity. When implemented as part of a predictor-corrector updating scheme, the no-flux condition at solid surfaces is maintained remarkably well.

The computational method used in this study depends on a fast elliptic solver which permits the computational grid to be stretched in one or two coordinate directions [14]. The reported computations have used at most a grid stretched vertically, but other of our computations have utilized a grid stretched independently in the horizontal directions.

3 Comparison with Measurements of Baines

For uniform density flows, it is convenient to express results in terms of a pressure coefficient $C_p = (p - p_0)/(\rho_0 V_0^2/2)$. where p_0 is the ambient pressure, ρ_0 is the ambient air density, and V_0 is a velocity characterizing the prevailing steady wind. Positive pressure coefficients indicate pressures above ambient and negative ones below ambient. For uniform flow, V_0 is this velocity, while for a shear flow V_0 is taken to be the velocity at the building height. In the studies of Baines and of the AIJ working group, the velocity profile was taken to have the form

$$V(z)/V_0 = (z/z_0)^{1/n} \tag{9}$$

where z_0 is a reference height, here taken to be the height of the building, V_0 is the reference velocity at that height and n is a number which varies with the roughness of the surface upstream of the building; the greater the roughness the smaller the value of n . The value 4 was selected for both the study of Baines and the AIJ working group; we use this value here. The reference velocity V_0 was taken to be 5 m/s.

Pressure-coefficient measurements were reported by Baines [7] on two buildings, the first a “tall building” with a square planform, one characteristic of many tall buildings constructed during that time (1963). The second building is a low building of cubical shape. For each building, Baines presents pressure-coefficient contours produced by uniform flow and compares these with the corresponding contours produced by boundary-layer flow. We report here the flow fields and the surface pressure-coefficients computed using our Large Eddy Simulation (LES) computational methodology and compare these results with the measurements of Baines. For both the tall and the cubical buildings, we contrast the pressure-coefficient contours produced by uniform flow with those generated by boundary-layer flow. The tall-building results are presented in subsection 3.1 while those for the cubical building are given in subsection 3.2.

3.1 Flow Over a Tall Building

Baines examines flow over a “tall building” using a wind tunnel in which the mean incoming wind profile could be adjusted to simulate the expected mean atmospheric wind profile. He measures the pressure patterns over the faces of the building. The tall building has dimensions (relative to the length of the side) 1 by 1 by 8 in the streamwise, cross-stream and vertical directions, respectively. Computations were performed to simulate his data.

For these computations, free slip BCs were chosen for the top and bottom as well as the sides of the computational domain (to provide spatially uniform upstream flows at the cross-wind boundaries of the computational domain). Along the upstream domain surface, the wind profile was specified while “open” BCs were used downstream. Since the Reynolds number for a model in a wind tunnel and, even more so, for a building at full scale in the atmosphere, is so much larger than the computational Reynolds numbers employed, we also used free-slip BCs on the building. (No-slip or partial slip boundary conditions made little difference on the pressure-coefficient distributions found on the building surfaces.) A computational domain 270 m long by 250 m wide by 160 m high was chosen with the building being 10 by 10 by 80 m in dimension. The building was centered in the cross-wind direction and was 150 m downstream from the face where the flow entered. The computational grid selected was $216 \times 216 \times 108$, yielding a total of 5,038,848 grid cells. With this resolution, we could use a Reynolds number for the computation of 2,020 based on the height of the building and the uniform 5 m/s flow. The grid was stretched in the vertical direction and was uniform in each of the horizontal directions. With this grid, there were approximately 8 mesh cells along the building in the streamwise direction, 8.6 cells in the cross-stream direction and 54 vertically. In each cell a pressure is computed. Therefore, if we regard each cell as a pressure tap, then there are approximately 430 pressure taps along each side, 460 taps on each the front and the back, and 69 taps on the top of the building.

The computational domain was chosen so that the location of the domain boundaries had little influence on the pressure coefficient distributions determined. Generally, for fixed computational resources (both computer memory and time), a larger physical region (used as the computational domain) reduces the influence of the BCs on the building, but also increases the size of each grid cell - thus reducing the resolution of the computation. Alternately, a smaller computational domain increases the computational resolution, but produces greater influence of the BCs on the flow field and surface pressure distribution. Higher resolution computations would allow larger Reynolds numbers or a larger dynamical range of scales to be resolved; however, higher resolution computations also require more memory and more CPU time. We regarded one day turn around as practical. The computations reported here were performed on one processor of an eight, 250 MHz R10000 processor SGI Onyx2 with 5.1 GB memory. However, all computations requiring less than a million grid cells, which were most of the computations, were carried out on an SGI Indigo II 195 MHz R10000 workstation with 512 MB memory, which is from 1/3 to 1/2 the speed of the Onyx2. ¹

¹These computers are identified to specify computational timings; recommendation or endorsement by NIST is not intended nor implied.

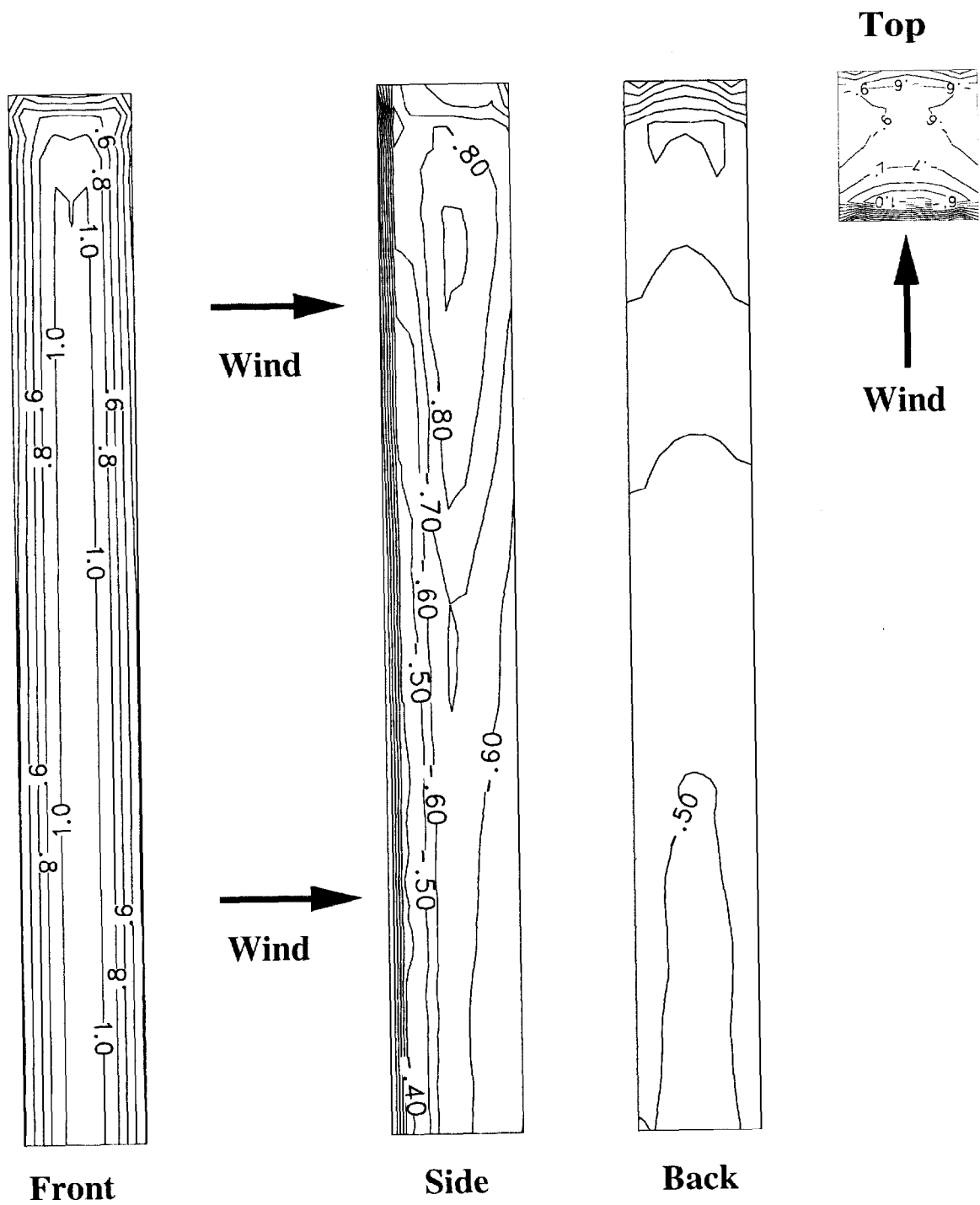

FIGURE 1: (a) Computed average pressure-coefficient contours on the front, side, back and top of the tall building for an incoming uniform flow. See text for details of the computation.

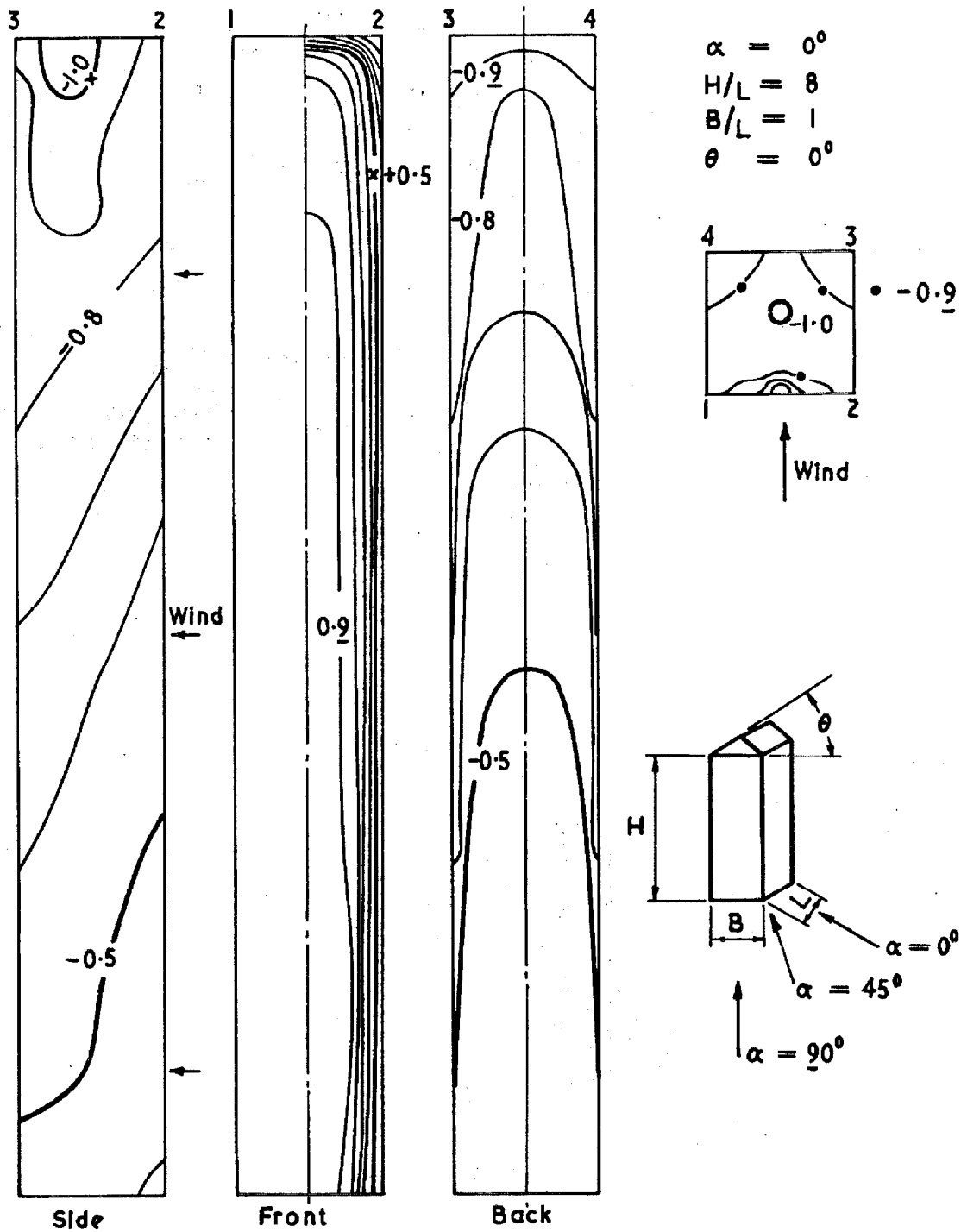

FIGURE 1: (b) Wind-tunnel measurements of these contours by Baines [7].

3.1.1 Uniform Flow

Figure 1(a) shows average pressure-coefficient contours on four surfaces, the front, the right side, the back and the top of the building. This plot has been generated to be comparable to Figure 2 of the paper of Baines, which is reproduced here as Figure 1(b). There is only one difference between these plots. In Baines' plot, contours are shown on the left side of the building, whereas our plot shows contours on the right side. By symmetry, the left side is the mirror image of the the right side. There is excellent qualitative agreement and good quantitative agreement between the plots. On the front of the building, the pressure coefficient is large (close to one) and nearly uniform both laterally from the centerline and from the base of the building to nearly the top. Along this high-pressure region, the contours are nearly two-dimensional (as is to be expected from the qualitative discussion of the uniform flow over a tall building described by Baines) with the pressure dropping off rapidly near the sides. Within two building widths of the top of the building, the pressure again drops off as the flow is deflected both laterally around and vertically over the top. (Note that the computations show an artifact of the limited resolution on the front near the top of the building.) The maximum difference between the computed and measured average pressure-coefficient contours on the front surface is of order ten percent. Along the top of the building, the pressure is lowest (the pressure coefficient is most negative), exhibiting measured values down to -1.0 near the center of the top. The computed values have their minimum of -1.0 near the front of the top and increase to about -0.6 near the back of the top. In the separated regions along the back and sides of the building, the pressure is less than ambient with the pressure gradually decreasing from the base to the top. Along the back, measurements show a decrease from -0.5 to -0.9 from bottom to top whereas the computations show a decrease from -0.5 to -0.8. Similarly, along the side, measurements show a decrease from -0.5 to -1.0, whereas computations show the minimum value near the top of -0.8. Also, along the side, measurements indicate that the pressure-coefficient contours generally slope from front to back. In contrast, computational results indicate that the pressure-coefficient contours reach a minimum near the center of the side and that this minimum decreases from bottom to top. Quantative differences appear to be about twenty percent at most.

This computation required 1415 time steps to complete 200 seconds of simulation time. It took about 27.5 CPU hours on a single processor and about 1.24 GB of memory. Therefore, the average time step during the computation required about 70.0 CPU seconds, which implies about $14\mu\text{s}$ per time step per mesh cell, a measure of computational efficiency.

3.1.2 Shear Flow

Next we consider the flow produced by a velocity profile simulating a mean atmospheric boundary layer. In Figure 2(a) is shown average pressure-coefficient contours on the front, side, back and top of the tall building for this case. Again, there is both good qualitative and quantitative agreement between the average pressure profiles obtained computationally and those measured by Baines. The pressure coefficient is highest near the top of the front of the building (exceeding 0.8 in the computations and 0.9 in the measurements) and decreases gradually toward the ground. On the top of the building, the suction is much less than in the case of uniform flow. For the measurements, the coefficient is nearly

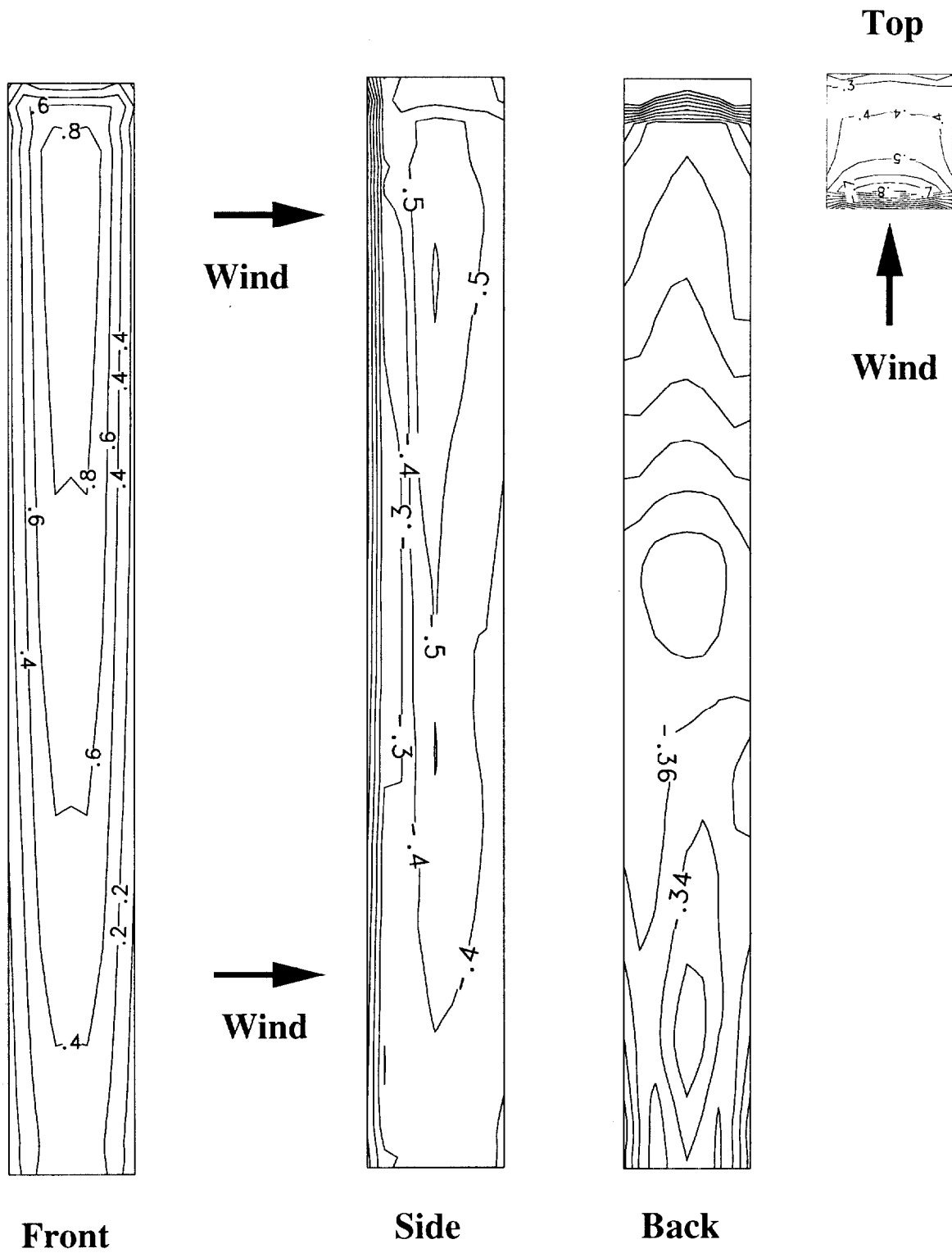

FIGURE 2: (a) Computed average pressure-coefficient contours on front, side, back and top of the tall building for an incoming atmospheric BL flow. See text for details of the computation.

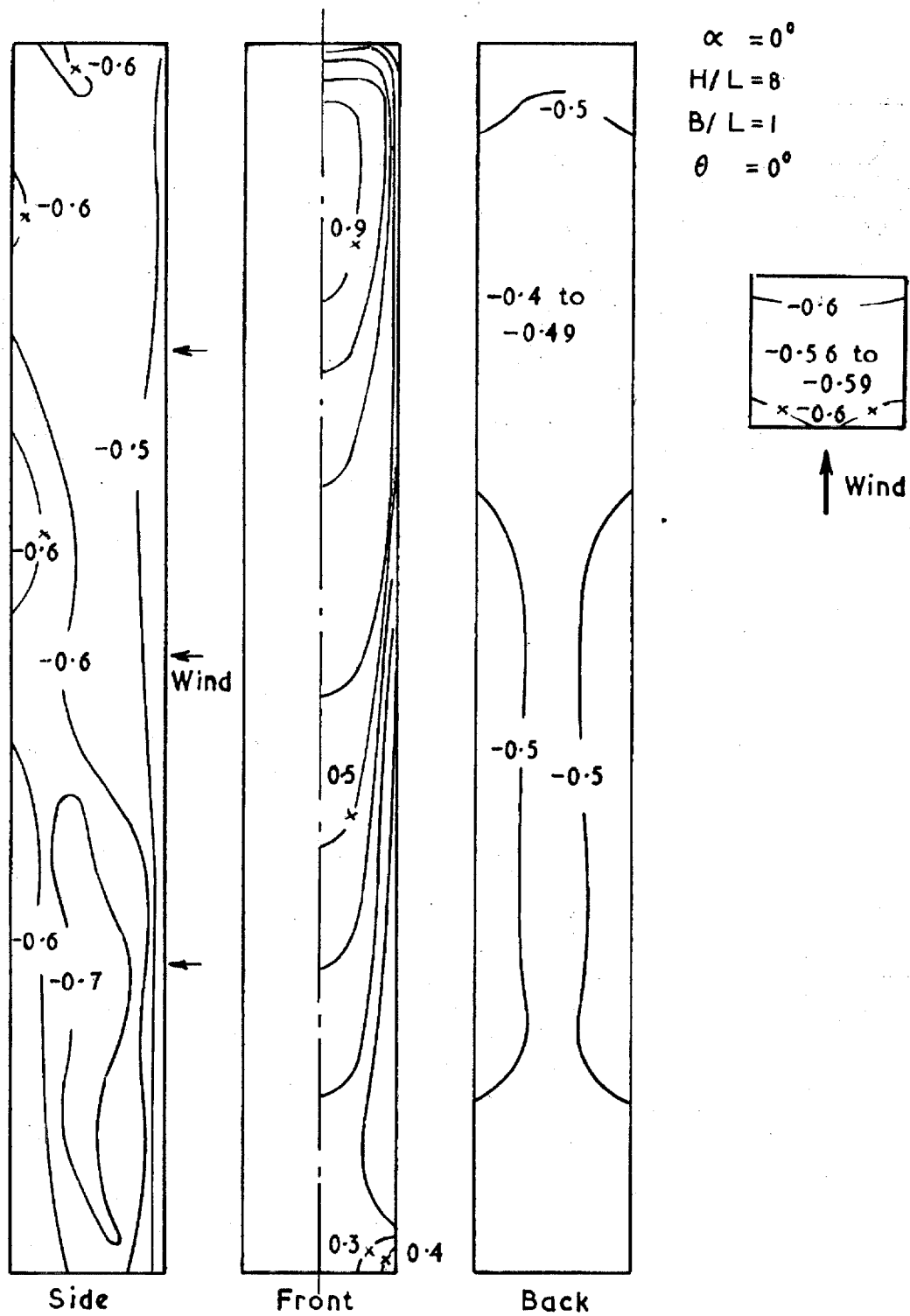

FIGURE 2: (b) Wind-tunnel measurements of these contours by Baines [7]

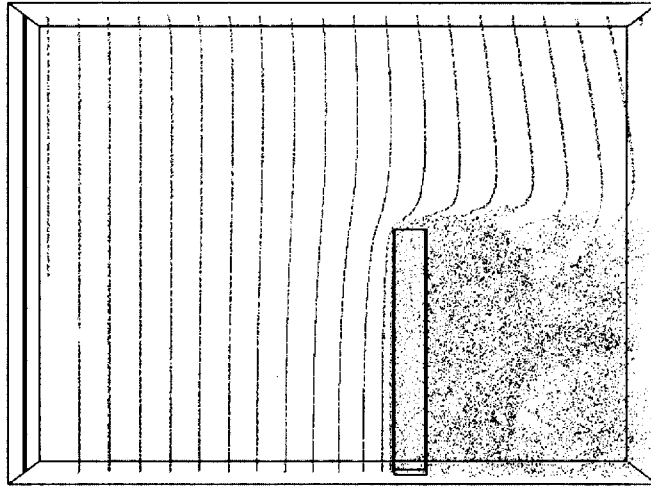

FIGURE 3: Side view of uniform flow over the tall building of Baines using particles injected at regular intervals for visualization.

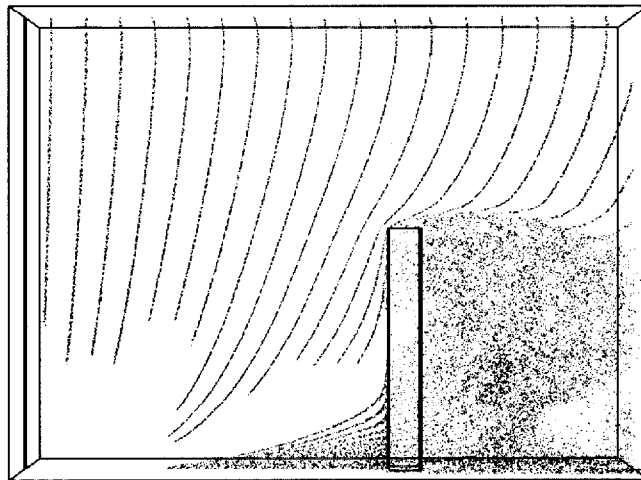

FIGURE 4: Side view of mean atmospheric BL flow over the tall building of Baines using particles injected at regular intervals for visualization.

uniform and between -0.5 and -0.6. The computations indicate, on the other hand that this coefficient reaches a minimum near the front of about -0.8 and slowly increases to -0.3. As Baines notes, the reduced suction for this case eliminates most of the pressure gradient along the side and back compared to the uniform-flow case. On the back of the building, the computations show almost no pressure variation from ground to top of the building, consistent with the measured results of Baines, reproduced here as Figure 2(b). This value varies between -0.4 and -0.5 according to the measurements, but is between -0.3 and -0.4 in the computations. Along the side of the building, the computations show low pressures, with the pressure coefficient varying between -0.3 and -0.5. The corresponding measured pressure coefficients show somewhat greater suction (ranging between -0.5 and -0.7), with again almost no gradient between the top and bottom of the building.

Finally, we contrast the transient behavior between uniform flow and shear flow over the tall building. To display this transient behavior, passive tracer particles were periodically introduced into the flow from a slot at the upstream face of the computational domain. These particles were carried by the flow over the building, showing the time-dependent mixing produced by the building. Figure 3 shows a particle plot at $t \approx 100$ s for uniform flow over the tall building while Figure 4 shows a similar plot for shear flow. The view is perpendicular to the flow direction, and the particles have been injected into the incoming flow at two-second intervals. In uniform flow, the injected stripes of particles move uniformly with almost no mixing from the domain inlet to the building. In the wake behind the building, on the other hand, there is vigorous mixing. By contrast, the shear flow stretches the stripes of particles with height in the flow direction, with little mixing as they move toward the building. For the shear flow, note the recirculation region in front of the building. In each case, a temporal sequence of such plots shows vigorous three-dimensional, time-dependent mixing on the sides and behind the building.

Taken together, these plots demonstrate, for the tall building, that the computations have captured very well the qualitative behavior and quite well the quantitative behavior found in the wind tunnel experiments of Baines. In his paper, Baines does not present enough information to determine the uncertainty in his measurements, but, he does note that the pressures were small and their measurement required great care. The uncertainty in the computed pressures is determined by the resolution, which is limited by the algorithms and the computer resources. In our case, resolution was dictated mostly by memory and CPU time available. As computers continue their revolutionary performance/price growth and computational algorithms continue to improve, it will be possible to compute flows to much higher resolution with much larger Reynolds numbers, covering a significantly greater dynamical range of length and time scales. Hence we will be able to calculate the surface pressure distributions with greater certainty and accuracy.

3.2 Flow Over a Cubical Building

In the next two subsections, computational results are compared with measurements reported by Baines for uniform and shear flows over a cubical building. For these computations, a domain of 270 m long by 350 m wide by 90 m high was employed. The mesh was uniform in each direction with 216 cells in the windward and cross-wind directions and 108 cells vertically for a total of 5,038,848 grid cells. Each computational cell was 1.02 m long by 1.62

m wide by 0.83 m high, so that the cube was described by about 29 nodes in the windward direction by 19 cells in the cross-wind direction by 36 nodes vertically. Since the pressure (as well as the velocity components) is computed at each grid cell, we can regard each cell as a pressure tap in the computation. Then, the front and back of the cube would have about 684 pressure taps, the sides about 1044 and the top about 551. We used a Reynolds number of approximately 1222 based on the incoming flow velocity, the height of the building and the grid resolution.

3.2.1 Uniform Flow

First, we show simulations of uniform wind-tunnel flow over a cube like that studied by Baines. In Figure 5 (a) is shown a composite plot of the computed pressure-coefficient contours on the front, right-side, top and back of the cube. This composite plot should be compared with the plots of experimental wind-tunnel measurements by Baines, reproduced here as Figure 5 (b). As expected, these plots show positive pressure coefficient contours on the front of the building with profiles having the same shapes and nearly the same values as in the results of Baines. (Since the maximum contour should not exceed 1.0, contour 1.05 provides a measure of errors in the computational results.) However, on other surfaces, where separation occurs, pressures are below ambient and pressure coefficients are more difficult to determine, there are differences between the experimental and computational results. On the top, the computed pressure coefficients are somewhat more negative (more suction) than reported by Baines, and there is considerably more structure in the computed contours. Baines finds that the pressure coefficient decreases slightly from -0.6 to -0.65 between front and back along the top. By contrast, the computations show the pressure coefficient decreases rapidly to -0.75 and then increases slowly back to -0.5 in going from front to back. Along the side, there are also qualitative differences. Computations show the pressure coefficient decreases rapidly to a minimum of about -0.7 near the top of the side and then increases to -0.5 at the rear. By contrast, the measurements show the pressure coefficient varies over a similar range, but increases then decreases from front to rear. On the back of the cube, the pressure-coefficient contours determined from the computations are smaller in magnitude and show more structure than those reported by Baines. The computed pressure-coefficient contours exhibit patterns on the top and side much more like those determined on the flat building in the AIJ study than those measured by Baines for the cube.

3.2.2 Shear Flow

The corresponding plots for shear flow over a cube are shown in Figures 6 (a) and (b); once again, composites of the pressure-coefficient contours on the front, side, back and top of the cube are shown. Comparison of Figure 6 (a) with Figure 5 (a) for the uniform flow shows some qualitative differences. The pressure-coefficient contours on all surfaces are smaller in magnitude than those in the uniform-flow case. The pressure-coefficient contours on the front of the building are only about eighty percent of those in the uniform-flow case for example. Also, the pressure on the front increases with distance from the ground with its maximum being nearly three quarters of the height of the building. For uniform flow, the pressure is largest near the ground and remains nearly constant at this value to about 2/3 of

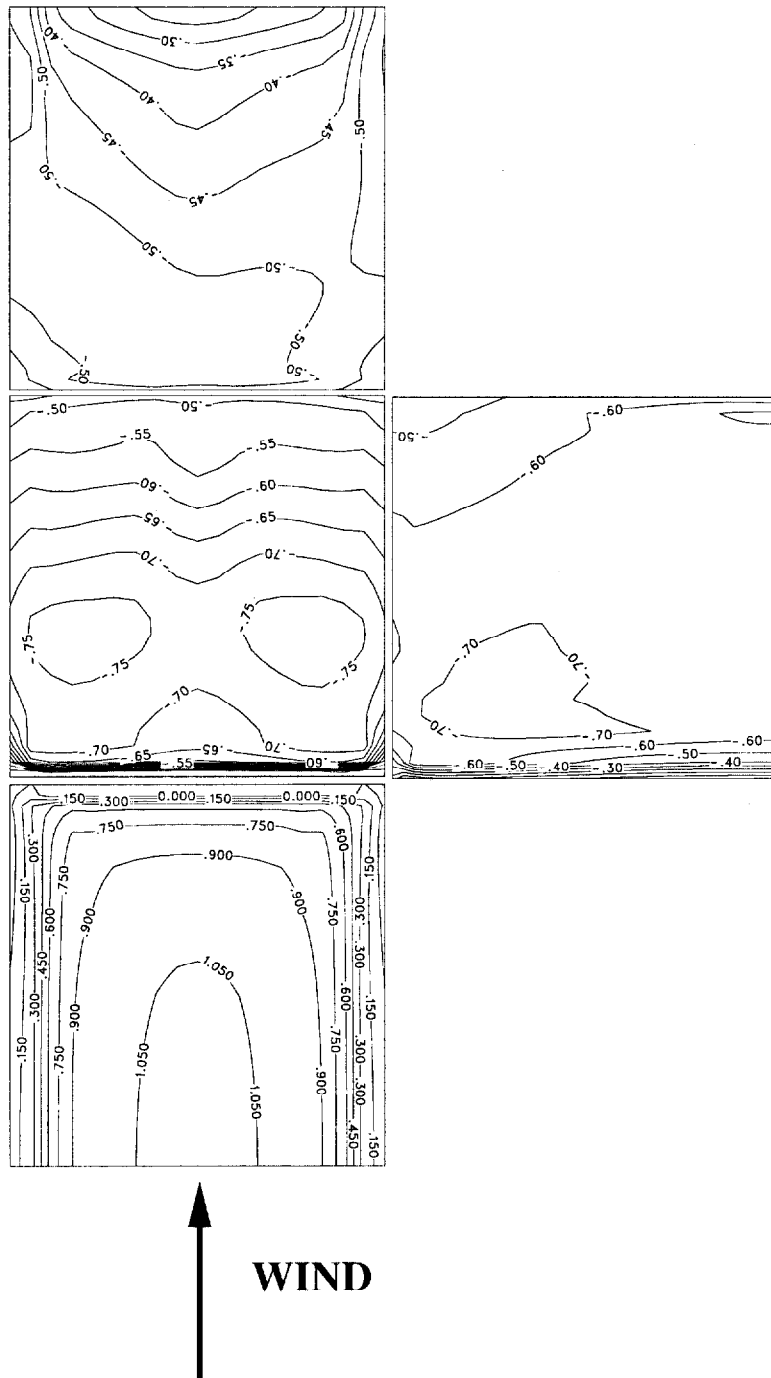

FIGURE 5: (a) Computed average pressure-coefficient contours on the front, side, back and top of the cubical building relative to the incoming uniform flow.

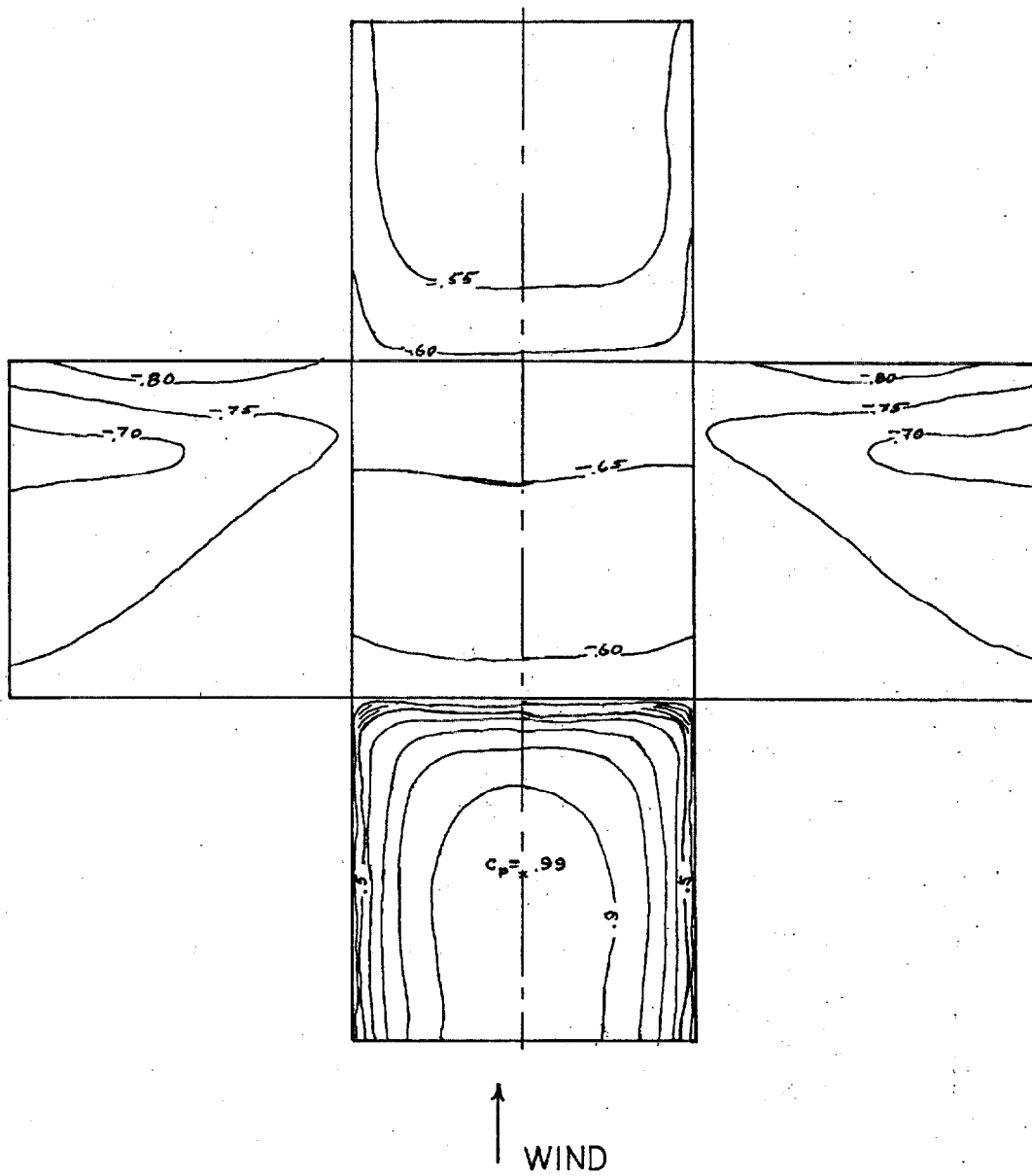

FIGURE 5: (b) Wind-tunnel measurements of these contours made by Baines [7]

the building height. These differences are expected from the discussion presented by Baines contrasting uniform versus boundary layer flow. They also show contrasts similar to the tall building results.

In the low-pressure regions where separation has occurred, the pressure coefficients are similar to those determined by Baines, but show some differences also. Baines finds that the pressure coefficient varies between -0.8 to about -0.2 from the front to the back of the top; the computations show a variation between -0.75 and -0.3, with the qualitative behavior captured very well. Along the side, the coefficient varies between -0.8 near the top and toward the front to -0.3 along the back of the side. The computations show a variation between -0.65 to -0.3 with the minimum value being somewhat above half-way up the side near the front. In the back, the experiments show little pressure coefficient variation around the value -0.2; the computations also show little variation, but the mean value is more like -0.25. Again, all in all, for the cube, the agreement is quite good we feel.

Next we contrast particle plots viewed from the top of the building for uniform flow (Figure 7) and shear flow (Figure 8). Flow deviation around the body occurs farther upstream in shear flow because of increased recirculation in front of the building. Such behavior was discussed extensively in the paper of Baines and is summarized in [6]. This recirculation forms a “horseshoe vortex” around the building in shear flow and is clearly seen in Figure 8. As before, these plots are instantaneous, and mixing is vigorous along the back and sides of the buildings. For example, periodic oscillation of the wake from side to side is found; deflection of the wake downward is clearly captured in Figure 7. The small obstruction to the side and downstream of the building is included to break the symmetry of the computation.

4 Comparison with Computations of Shah & Ferziger

In an interesting paper, Shah and Ferziger [3] studied flow over a cube using Large Eddy Simulations (LES). While much of their methodology is similar to ours, many details are different. Two important differences contribute, most likely, to greater flexibility in their methods, but to greater efficiency in ours. They use a grid which is non-uniform in all three directions while ours can be non-uniform in two directions at most. To satisfy continuity over this general grid, they utilize a multigrid procedure to solve a Poisson equation for a pressure-like variable. We solve the Poisson equation, Eq. (5), by fast, direct methods as noted earlier, a very efficient process. They also use a dynamic subgrid turbulence model whereas we use a constant eddy viscosity determined by the resolution of the grid.

They discuss the advantages of LES and compare computed flow characteristics with wind-tunnel measurements obtained by Martinuzzi and Tropea [16], who visualize the time-averaged velocity patterns of the flow. The comparisons include time-averaged streamwise velocity, turbulence stress and streamlines on the flow symmetry plane. In addition, Shah and Ferziger show time-averaged streamlines along the floor of the channel and in a plane behind the cube. These visualizations of both experimental and computational results provide an excellent understanding of the mean flow characteristics over a cube. They also show the time history and the spectrum of the side force on the cube. In addition, Martinuzzi and Tropea display average streamwise and cross-stream pressure coefficient profiles both for a cube and for more general prismatic obstacles of different spanwise dimensions. The experiments are

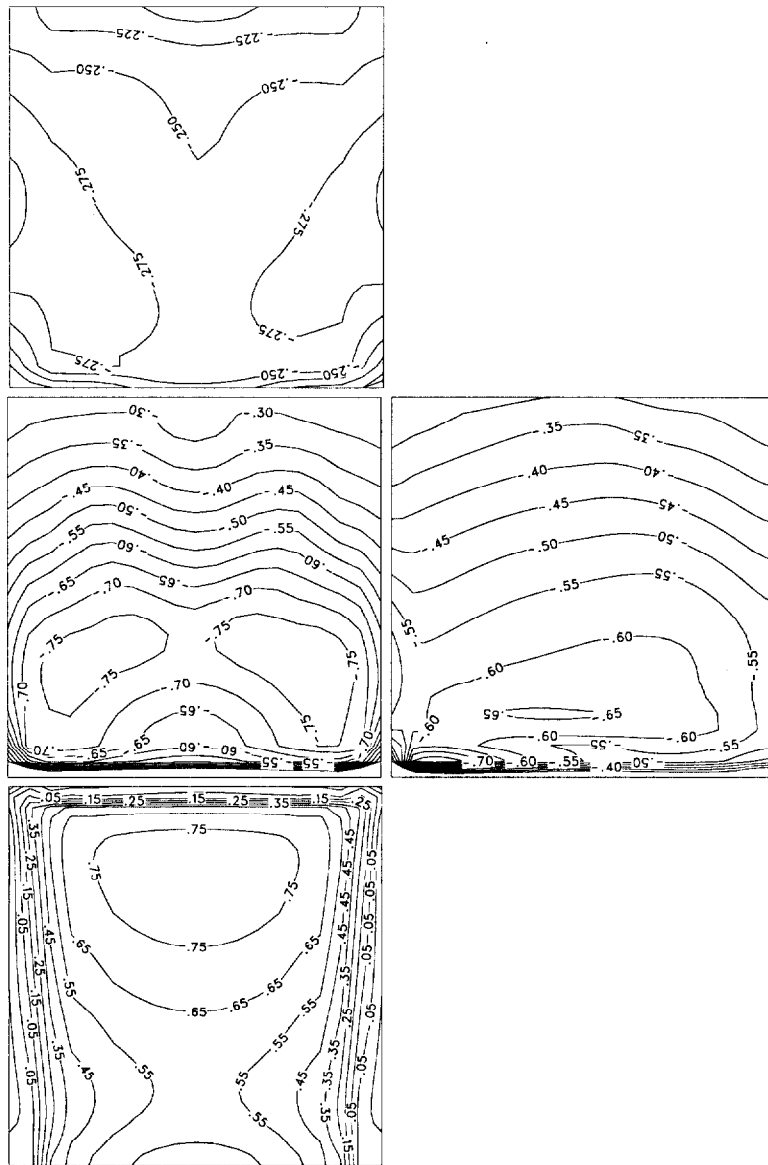

FIGURE 6: (a) Computed average pressure contours on front, side, back and top of the cubical building in shear flow.

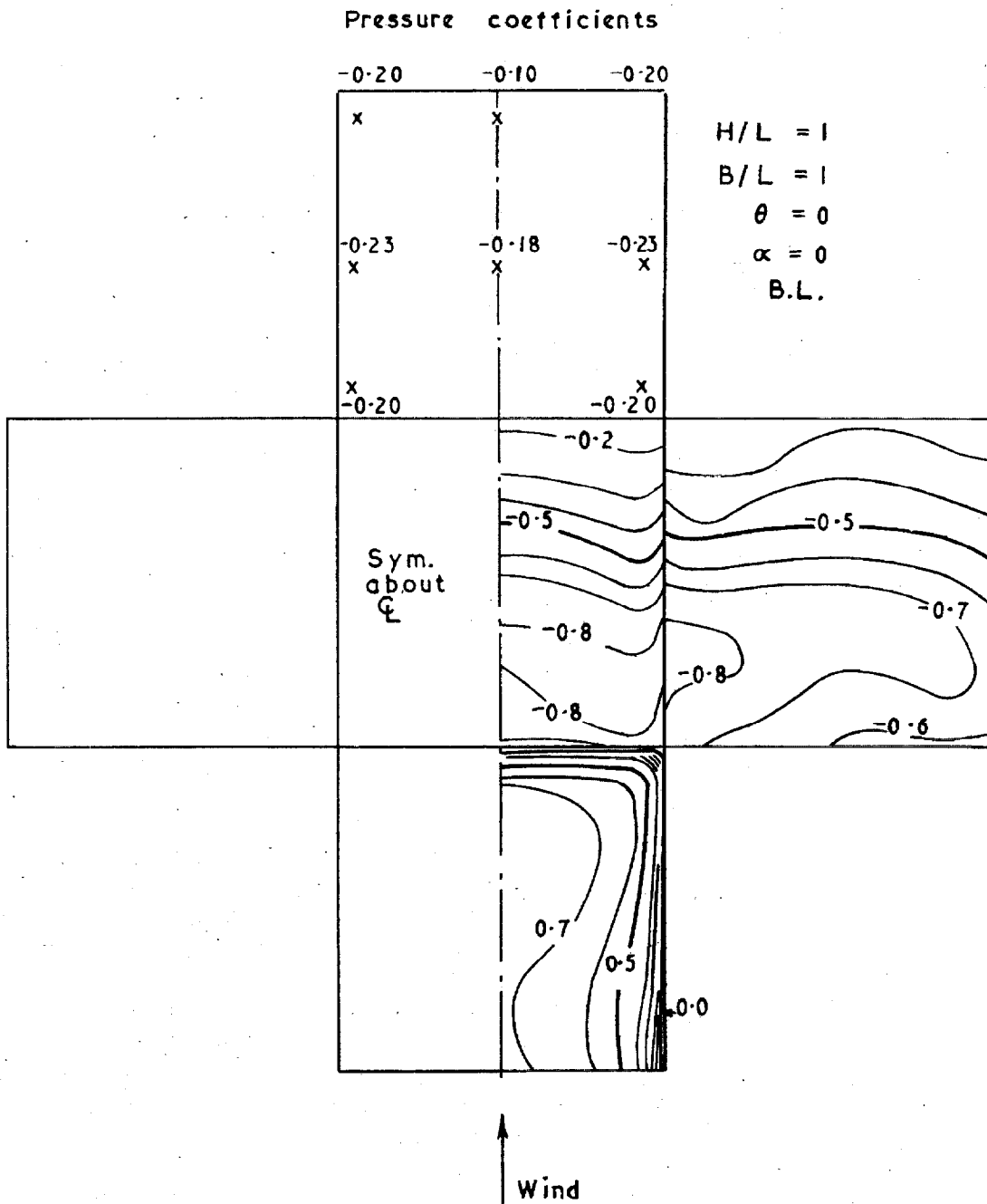

FIGURE 6: (b) Wind-tunnel measurements of these contours by Baines [7].

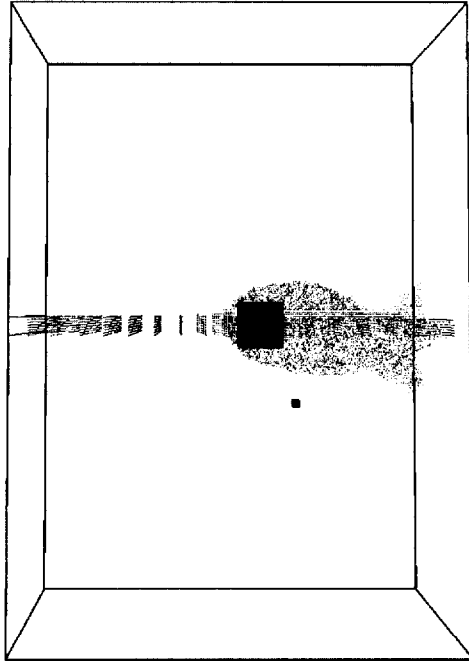

FIGURE 7: Top view of uniform flow over the square building of Baines using particles injected at regular intervals for visualization.

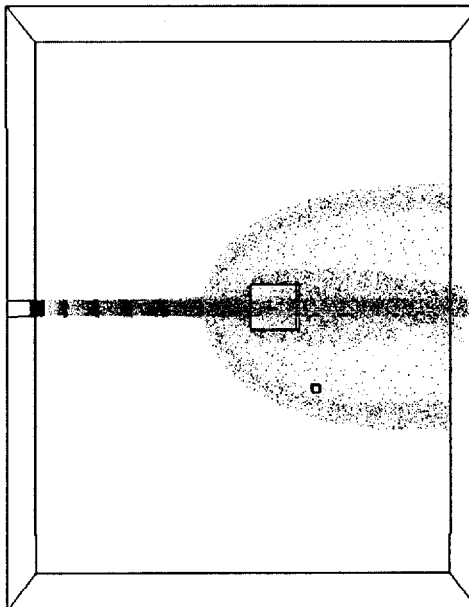

FIGURE 8: Top view of BL flow over the cubical building of Baines using particles injected at regular intervals for visualization.

carried out in a fully developed turbulent channel flow, which Shah and Ferziger simulate by imposing a comparable average incoming velocity profile. Shah and Ferziger emphasize that modelers must simulate the overall flow field to obtain appropriate surface pressure fields.

As described in the previous section, we computed the flow over a cube with an incoming uniform velocity profile; we did not attempt to simulate the fully developed turbulent channel velocity profile since this profile is approximately uniform except in very narrow boundary-layer regions near the walls. While the computations of Shah and Ferziger are also very high resolution, they take of order 300 CPU hours on a vector supercomputer for the results reported in their paper. By contrast, the computations reported here are qualitatively the same, but can be run in from one to three days on our desktop workstation. The efficiency of these computations makes them practical for wind-engineering studies.

Plots similar to those presented by Shah and Ferziger, namely time-averaged streamlines along the floor of the channel and along the symmetry plane are shown in Figures 9 and 10 respectively. These figures show good qualitative agreement with Figures 5 and 6 of that paper and yield a good understanding of the features of the time-averaged flow field. While the quantitative comparisons that Shah and Ferziger make between their time-averaged streamwise velocities and turbulence intensities and the measurements of Martinuzzi and Tropea are good, no mention is made of average pressure distributions on the body surfaces. These pressure distributions are very important for the engineer and can be calculated incorrectly if the body is not properly placed in the computational domain. In our computations we found that the mean pressures on the front of the obstacle were significantly larger than those reported by Baines [7], for example, when the obstacle is too close to the computational flow inlet (i.e., too far forward in the computational domain) as seemed to be the case in the computation of Shah and Ferziger. Average pressure-coefficient profiles were found to be consistent with those measured by Baines when the body placement in the computational domain was as described in Section 3. Once again, the small obstacle to the side and downstream of the cube in Figure 9 is included to break the symmetry of the computation.

5 Comparison with AIJ Report Results

A working subgroup of the Architectural Institute of Japan (AIJ) [8] has studied extensively a low-flat building with dimensions 1:1:0.5 (length: width: height) both computationally and experimentally in a wind tunnel. These extensive studies required a power-law shear-layer profile with exponent of 1/4 (the same profile as considered by Baines [7]). The domain (the wind-tunnel measurement domain or the computational domain) was also specified, and the direction of the incoming wind could be normal to the building front surface or have an angle of 22.5 or 45 degrees. The study reported in [8] appears to contain the most comprehensive comparisons of wind-tunnel and computational results available to date.

Unfortunately, the AIJ study reports very few details of each individual study so that direct and detailed comparisons will be difficult. Most of the computational results reported in the study use the $k - \epsilon$ turbulence model, although some LES results are presented. However, the computational grid sizes are not reported in [8].

The following figures show results of our computations attempting to simulate normal flow (0 degrees) over the low-flat building specified in the AIJ report [8]. The computational

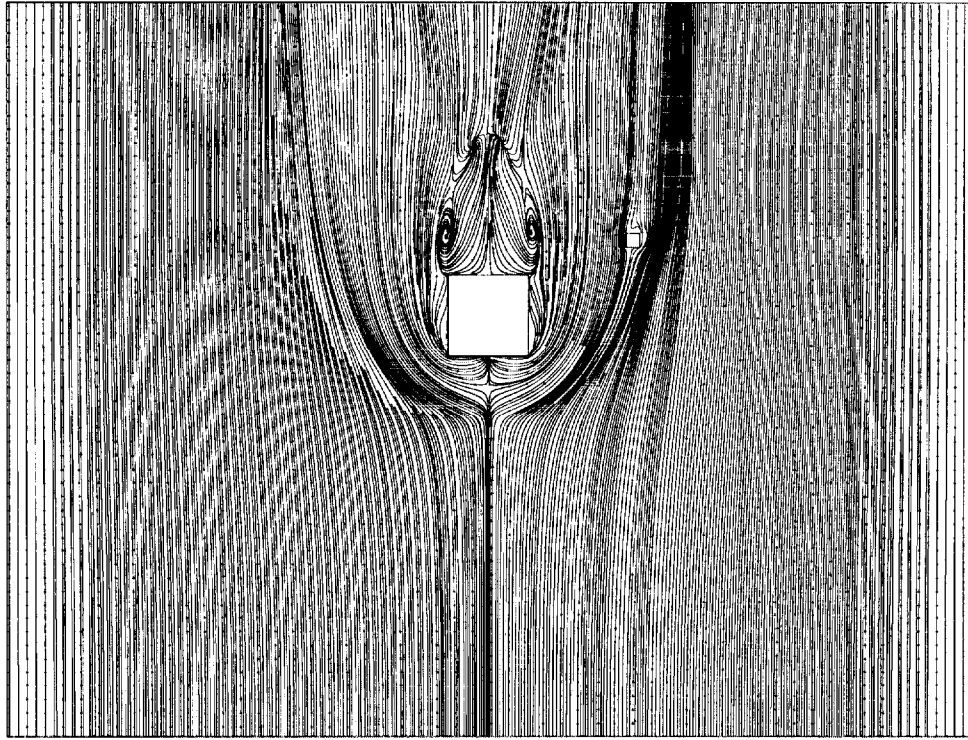

FIGURE 9: Average streamlines along the floor of the channel as computed by our LES methodology. Compare with Figure 5 of the paper of Shah and Ferziger [3].

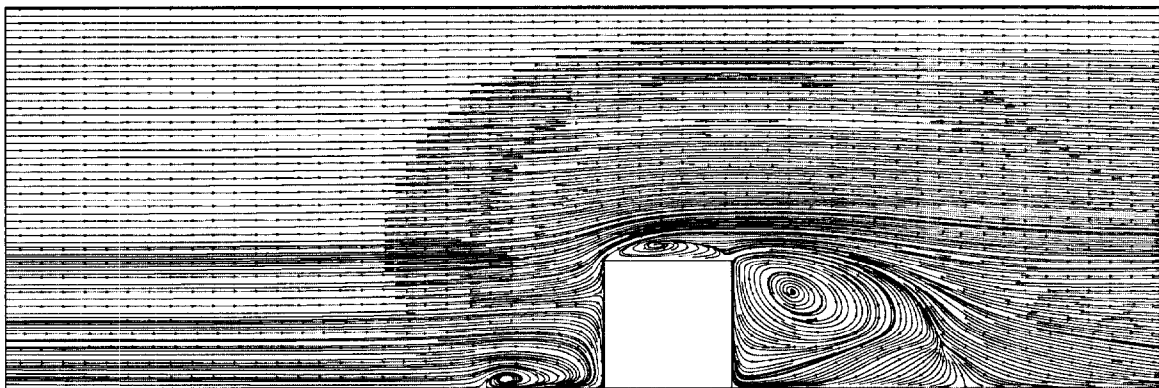

FIGURE 10: Average streamlines on the plane of symmetry as computed by our LES methodology. Compare with Figure 6 of the paper of Shah and Ferziger [3].

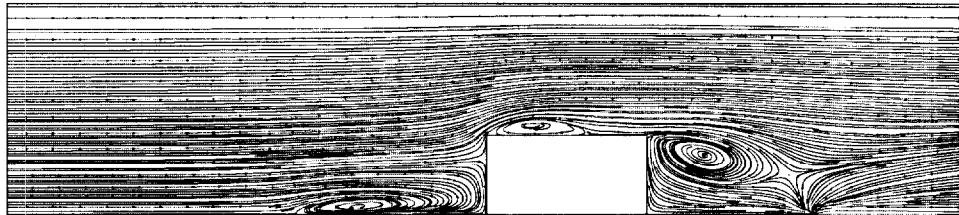

FIGURE 11: Average streamlines over the flat building used in the AIJ study [8] on the plane of symmetry as computed by our LES methodology for an incoming shear flow.

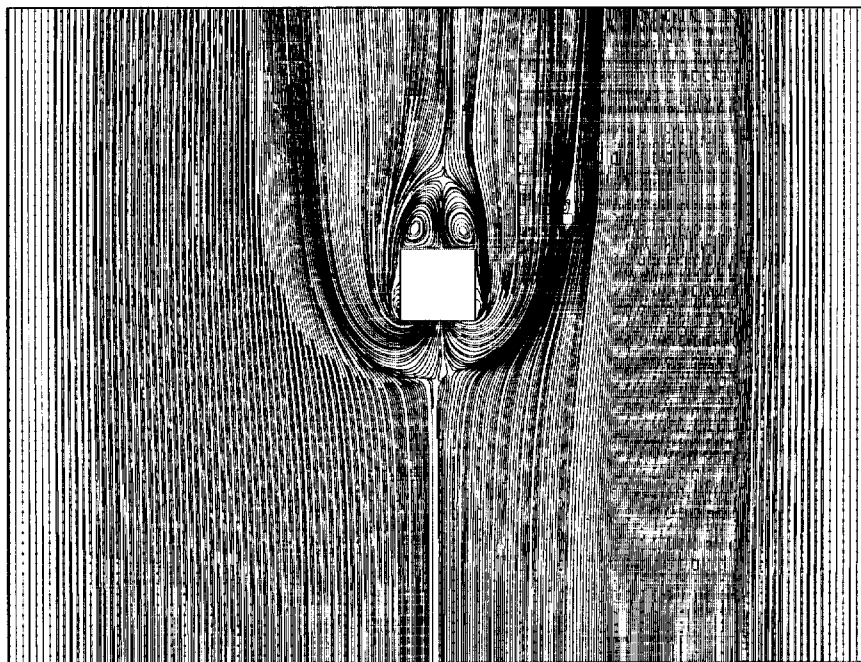

FIGURE 12: Average streamlines over the flat building used in the AIJ study [8] along the floor of the channel as computed by our LES methodology for an incoming shear flow.

domain used was 270 m by 350 m by 45 m in the streamwise, cross-stream and vertical directions. The building was taken to be 30 m by 30 m by 15 m and was 140 m from the flow inlet. A grid of 256 by 256 by 64 = 4,194,304 cells was used, permitting a Reynolds number $Re=1964$, based on the building height and the incoming flow velocity (5 m/s) at that height. The velocity profile was the same as specified in the AIJ report. Figure 11 shows the time-averaged streamlines in the plane of symmetry of the flow and Figure 12 shows these streamlines along the ground. As in previous plots, the small obstacle to the side and downstream of the building is included to break the symmetry of the computation. Finally, Figure 13 and 14 show the pressure-coefficient contours on the surfaces of the low-flat building for a uniform incoming flow and for a 1/4 shear flow respectively. These pressure-coefficient contours are in good agreement with the experimental contours of the mean pressure coefficient presented in the AIJ report; those plots are reproduced here as Figures 15 and 16. Qualitatively, the contours look very much alike, while the quantitative differences are within thirty percent at most.

6 Summary and Conclusions

Results of computations using large eddy simulations (LES) to simulate normal flow over buildings of three shapes were reported. Two different incoming flow profiles, a uniform flow and a 1/4 power shear flow (simulating an atmospheric boundary layer) were investigated. These simulations were performed at high resolution (using over five million grid cells for some of the three-dimensional computations) and showed highly time-dependent flow behavior. Only mean properties of the flow field were reported with primary concentration on surface pressure profiles since building surface pressure is of great importance for wind engineering. Comparisons of these results with experimental measurements of Baines [7] and of the AIJ [8] study were also made. The favorable agreement arising from these comparisons justify the use of this LES methodology for additional CWE computations. In some cases mean flow fields were also displayed as time averaged streamlines in planes intersecting the flows along the ground or along the plane of symmetry. Transient behavior was not reported, even though it is of critical importance and is vividly displayed in the simulations. (The instantaneous particle plots, Figures 3,4,7 and 8, suggest this vigorous transient behavior.)

Pressure fluctuation distributions were not computed and reported here: we believe that determination of these distributions will require separate study including more detailed specification of the temporal and spatial variability of the incoming flow. Characteristics of the incoming flow generated in a wind tunnel will most likely differ greatly from the characteristics of the incoming flow at full scale. The local meteorology, terrain and vegetation, as well as the nearby buildings, will change substantially the temporal and spatial characteristics of this incoming flow. As mentioned in the Introduction, measurements from wind-tunnel experiments are most straightforward to compare with results of numerical simulations because these experiments are controlled and reproducible. Simulations of flow over full-scale structures are ultimately what is desired, however, and these are impossible to control and much more difficult to obtain.

The local meteorology requires atmospheric data or models on the scale associated with weather prediction. Flow fields are often characterized by mean values of the quantities and

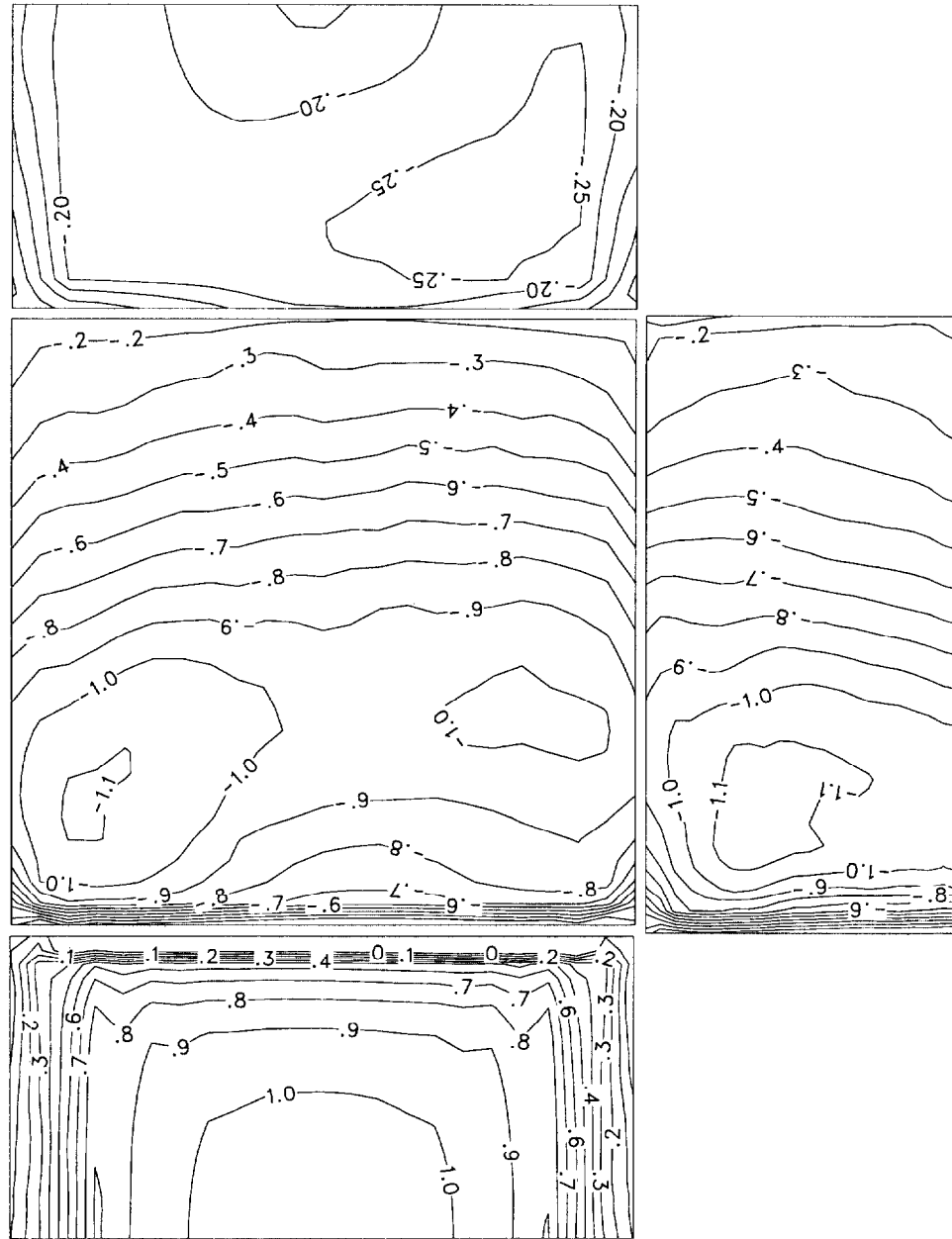



Wind

FIGURE 13: Pressure-coefficient contours on the surfaces of the low-flat building (building ratios 1:1:05) for uniform flow.

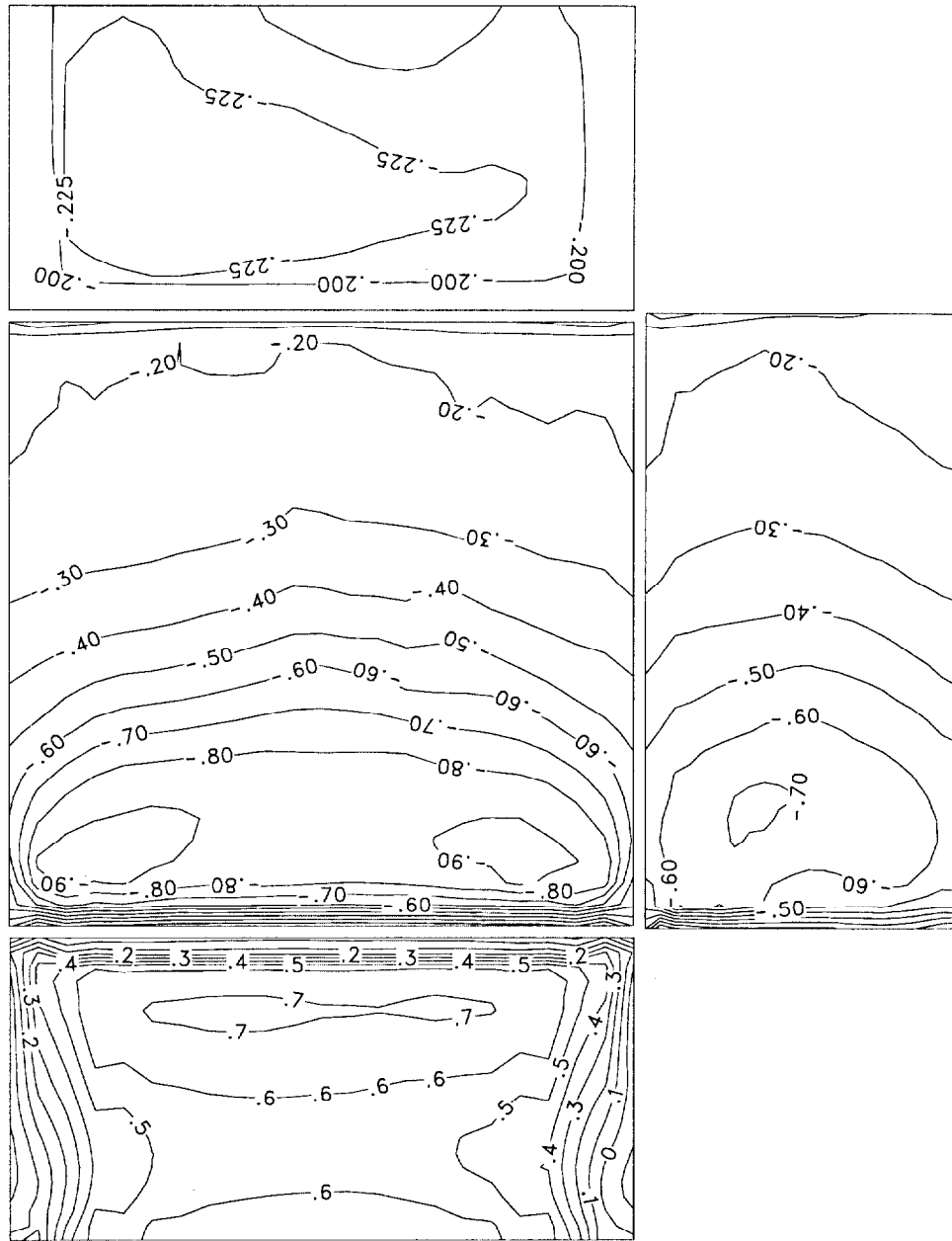

FIGURE 14: The pressure coefficient on the surfaces of the low-flat building (building ratios 1:1:05) for shear flow.

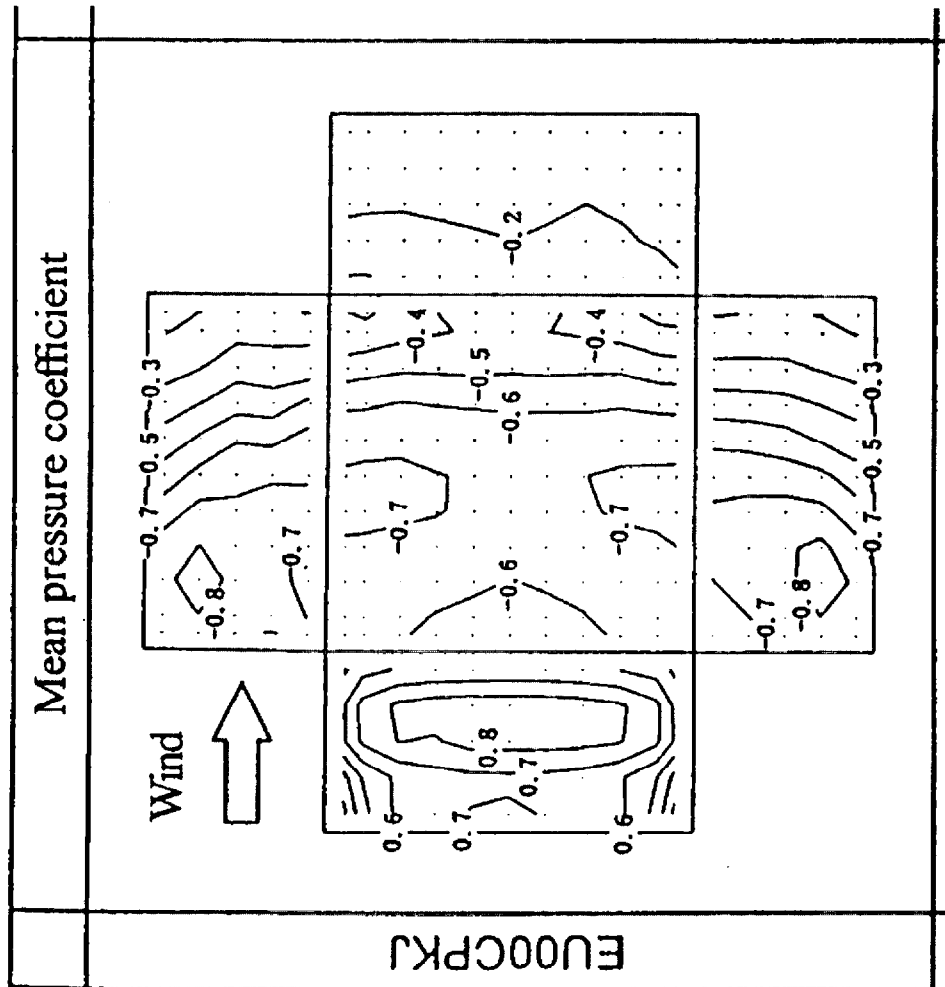

FIGURE 15: The pressure coefficient for uniform flow from the AIJ Report.

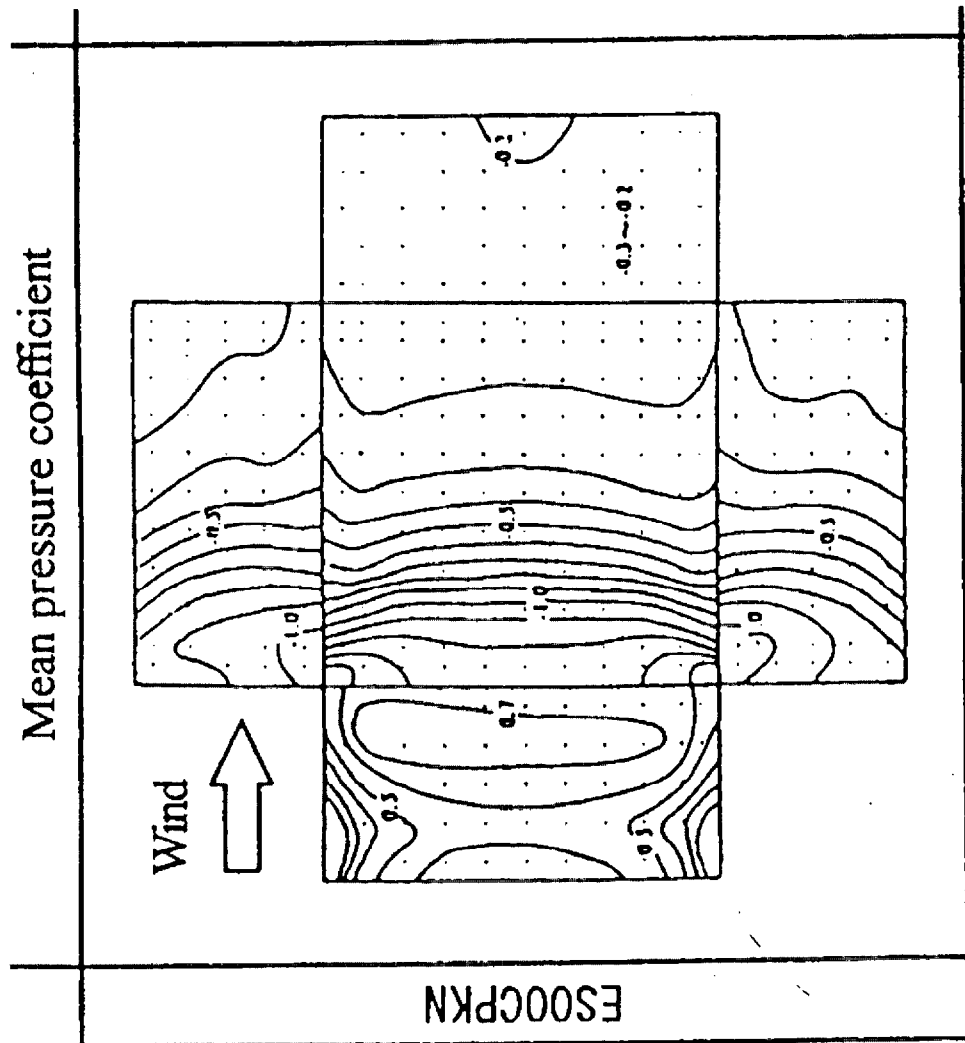

FIGURE 16: The pressure coefficient for shear flow from the AIJ Report.

fluctuations about the mean. The fluctuations are generally described as due to turbulence. However, for computations on a grid of characteristic number N in each direction (so that the total number of grid cells is $O(N^3)$), there are two length scales that characterize the simulations, a large scale L which characterizes the size of the domain and a small scale $l = O(L/N)$ that characterizes the grid size. The computation can approximately resolve all length scales x between these two characteristic scales, $l \leq x \leq L$. All lengths larger than L will not be treated adequately, while all length scales smaller than l are inherently not resolvable on the grid available. Described in another way, the computations can resolve a range of values in wavenumber k space ranging approximately between $1/L \leq k \leq 1/l$. For transient computations, there is a smallest time scale τ associated with l , and fluctuations with time scales below τ also cannot be resolved. Viewed in this fashion, turbulence with length scales below l cannot be resolved whereas fluctuations in dependent variables with length scales greater than l need not be regarded as turbulence in a time-dependent, spatially resolved computation. By the same token, the large scale variations in the dependent variables along the computational domain boundaries must be specified from meteorological data or models.

Our studies also indicate that the local topography, both natural and man made, are extremely important to predicting transient pressure patterns on an individual building. Neighboring structures (as well as wind magnitude and direction) exert enormous effects on the transient flow field and hence upon the pressure around a building. If one is to model successfully the fluctuations in the flow field around an individual building, it must be in the context of knowing the local meteorology, the local natural topography and the neighboring built environment. Furthermore, one should also specify not only wind speed, but also quantities such as wind direction, wind shear and atmospheric stability as well. We expect to examine these questions in future studies.

- [1] Meroney, Robert and Bogusz Bienkiewicz (editors), Computational Wind Engineering 2: Proceedings of the 2nd International Symposium on Computational Wind Engineering (CWE 96), Fort Collins, Colorado, 4-8 August 1996, *J. Wind Engineering and Industrial Aerodynamics*, Vols. 67 & 68, April-June 1997.
- [2] Murakami, Shuzo, "Current Status and Future Trends in computational Wind Engineering," *J. Wind Engineering and Industrial Aerodynamics*, Vols. 67 & 68, pp 3-34, 1997.
- [3] Shah, Kishan B. and Joel H. Ferziger, "A Fluid Mechanics View of Wind Engineering: Large Eddy Simulation of Flow Past a Cubic Obstacle," *J. Wind Engineering and Industrial Aerodynamics*, Vols. 67 & 68, pp 211-224, 1997.
- [4] Pielke, Roger A. and Melville E. Nicholls, "Use of Meteorological models in Computational Wind Engineering," *J. Wind Engineering and Industrial Aerodynamics*, Vols. 67 & 68, pp 363-372, 1997.

- [5] Stathopoulos, Theodore, "Computational Wind Engineering: Past Achievements and Future Challenges," *J. Wind Engineering and Industrial Aerodynamics*, Vols. 67 & 68, pp 509-532, 1997.
- [6] Simiu, Emil and Robert H. Scanlan, *Wind Effects on Structures*, John Wiley & Sons, Inc., Third Edition, 1996, Chapter 4.
- [7] Baines, W. Douglas, "Effects of Velocity Distribution on Wind Loads and Flow Patterns on Buildings", Volume I, Proceedings of the National Physical Laboratory Symposium 16, *Wind Effects on Buildings and Structures*, NPL, Teddington, England, 26-28 June 1963.
- [8] "Numerical Prediction of Wind Loading on Buildings and Structures," The working group for numerical prediction of wind loading on buildings and structures, Subcommittee for wind engineering data unit for structural design, Architectural Institute of Japan, March 1998.
- [9] K.B. McGrattan, Baum, H.R. and R.G. Rehm, "Large Eddy Simulations of Smoke Movement," *Fire Safety Journal*, Vol. 30, pp. 161-178, 1998.
- [10] Baum, H.R., O.A. Ezekoye, K.B. McGrattan and R.G. Rehm, Mathematical Modeling and Computer Simulation of Fire Phenomena, *Theoretical and Computational Fluid Dynamics*, Vol. 6, 1994, pp. 125-139.
- [11] McGrattan, K.B., Baum, H.R., and Rehm, R.G., Numerical Simulation of Smoke Plumes from Large Oil Fires, *Atmospheric Environment*, Vol. 30, No. 24, 1996, pp. 4125-4136.
- [12] McGrattan, K.B., Rehm, R.G., and Baum, H.R., "Fire-Driven Flows in Enclosures", *J. Comp. Phys.*, Vol. 110, pp. 285-291, 1994.
- [13] Peyret, R. and Taylor, T.D., *Computational Methods for Fluid Flow*, Springer-Verlag, New York, 1983.
- [14] Swarztrauber, Paul and Roland Sweet, Efficient Fortran Subprograms for the Solution of Elliptic Partial Differential Equations, NCAR Technical Note, NCAR-TN/IA-109, National Center for Atmospheric Research, Boulder, Colorado, July 1975.
- [15] Rehm, R.G. and H.R. Baum, "The Equations of Motion for Thermally Driven, Buoyant Flows", *Journal of Research of the NBS*, 83, pp 297-308, May-June 1978.
- [16] Martinuzzi, R. and C. Tropea, "The Flow Around Surface-Mounted, Prismatic Obstacles Placed in a Fully Developed Channel Flow," *J. Fluids Engineering*, Vol. 115, 1993, pp. 85-92.
- [17] Smagorinsky, J., "General Circulation Experiments with the Primitive Equations, 1. The Basic Experiment," *Mon. Wea. Rev.*, Vol. 91, 1963, pp. 99-165

NIST-114 (REV. 11-94) ADMAN 4.09	U.S. DEPARTMENT OF COMMERCE NATIONAL INSTITUTE OF STANDARDS AND TECHNOLOGY		(ERB USE ONLY)	
			ERB CONTROL NUMBER	DIVISION
			PUBLICATION REPORT NUMBER	CATEGORY CODE
			PUBLICATION DATE	NUMBER PRINTED PAGES
MANUSCRIPT REVIEW AND APPROVAL				
INSTRUCTIONS: ATTACH ORIGINAL OF THIS FORM TO ONE (1) COPY OF MANUSCRIPT AND SEND TO THE SECRETARY, APPROPRIATE EDITORIAL REVIEW BOARD.				

TITLE AND SUBTITLE (CITE IN FULL) An Efficient Large Eddy Simulation Algorithm for Computational Wind Engineering: Application to Surface Pressure Computations on a Single Building		CONTRACT OR GRANT NUMBER	TYPE OF REPORT AND/OR PERIOD COVERED
AUTHOR(S) (LAST NAME, FIRST INITIAL, SECOND INITIAL) R.G. Rehm, K.B. McGrattan, H.R. Baum & E. Simiu		PERFORMING ORGANIZATION (CHECK (X) ONE BLOCK) <input checked="" type="checkbox"/> NIST/GAITHERSBURG <input type="checkbox"/> NIST/BOULDER <input type="checkbox"/> JILA/BOULDER	

LABORATORY AND DIVISION NAMES (FIRST NIST AUTHOR ONLY) Building and Fire Research Laboratory/Fire Safety Engineering Division
SPONSORING ORGANIZATION NAME AND COMPLETE ADDRESS (STREET, CITY, STATE, ZIP)

PROPOSED FOR NIST PUBLICATION		
<input type="checkbox"/> JOURNAL OF RESEARCH (NIST JRES) <input type="checkbox"/> J. PHYS. & CHEM. REF. DATA (JPCRD) <input type="checkbox"/> HANDBOOK (NIST HB) <input type="checkbox"/> SPECIAL PUBLICATION (NIST SP) <input type="checkbox"/> TECHNICAL NOTE (NIST TN)	<input type="checkbox"/> MONOGRAPH (NIST MN) <input type="checkbox"/> NATL. STD. REF. DATA SERIES (NIST NSRDS) <input type="checkbox"/> FEDERAL INF. PROCESS. STDS. (NIST FIPS) <input type="checkbox"/> LIST OF PUBLICATIONS (NIST LP) <input checked="" type="checkbox"/> NIST INTERAGENCY/INTERNAL REPORT (NISTIR)	<input type="checkbox"/> LETTER CIRCULAR <input type="checkbox"/> BUILDING SCIENCE SERIES <input type="checkbox"/> PRODUCT STANDARDS <input type="checkbox"/> OTHER ASCE Journal of Aerosp

PROPOSED FOR NON-NIST PUBLICATION (CITE FULLY)	<input checked="" type="checkbox"/> U.S.	<input type="checkbox"/> FOREIGN	PUBLISHING MEDIUM <input checked="" type="checkbox"/> PAPER	<input type="checkbox"/> CD-ROM
			<input type="checkbox"/> DISKETTE (SPECIFY)	
			<input type="checkbox"/> OTHER (SPECIFY)	

SUPPLEMENTARY NOTES

ABSTRACT (A 2000-CHARACTER OR LESS FACTUAL SUMMARY OF MOST SIGNIFICANT INFORMATION. IF DOCUMENT INCLUDES A SIGNIFICANT BIBLIOGRAPHY OR LITERATURE SURVEY, CITE IT HERE. SPELL OUT ACRONYMS ON FIRST REFERENCE.) (CONTINUE ON SEPARATE PAGE, IF NECESSARY.) An efficient large eddy simulation algorithm is used to compute mean surface pressure distributions on an isolated building of various rectangular shapes. Two incoming mean wind profiles are considered in these computations, one uniform with height and the other increasing as a power law with height. The second profile accounts for flow retardation due to friction from the surface of the earth; in neither case are turbulent fluctuations included in the work. Mean pressure distributions are computed for a tall building (1 by 1 by 8, length by width by height), a cubical building and a flat building (1 by 1 by 0.5). These computational results are compared with wind tunnel measurements and computations performed by other investigators. The agreement in most cases is very good with differences of approximately twenty percent at most.
--

KEY WORDS (MAXIMUM OF 9; 28 CHARACTERS AND SPACES EACH; SEPARATE WITH SEMICOLONS; ALPHABETIC ORDER; CAPITALIZE ONLY PROPER NAMES) building aerodynamics; computational wind engineering; large eddy simulation; surface pressure; wind effects

AVAILABILITY <input checked="" type="checkbox"/> UNLIMITED	<input type="checkbox"/> FOR OFFICIAL DISTRIBUTION - DO NOT RELEASE TO NTIS	NOTE TO AUTHOR(S): IF YOU DO NOT WISH THIS MANUSCRIPT ANNOUNCED BEFORE PUBLICATION, PLEASE CHECK HERE.
<input type="checkbox"/> ORDER FROM SUPERINTENDENT OF DOCUMENTS, U.S. GPO, WASHINGTON, DC 20402		
<input checked="" type="checkbox"/> ORDER FROM NTIS, SPRINGFIELD, VA 22161		