

Optimization of Polymer Concrete Composites:
Final Report

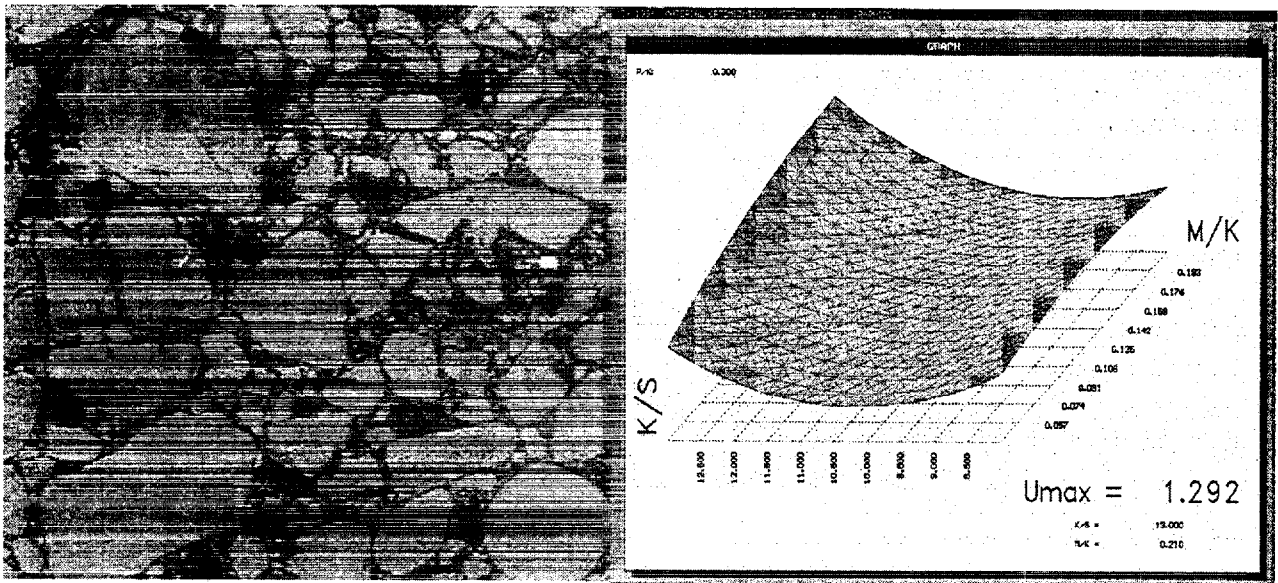

Lech Czarnecki, Andrzej Garbacz, Pawel Lukowski
Warsaw University of Technology
Warsaw, Poland

James R. Clifton
Building and Fire Research Laboratory
Gaithersburg, Maryland



United States Department of Commerce
Technology Administration
National Institute of Standards and Technology

Optimization of Polymer Concrete Composites:
Final Report

Lech Czarnecki
Andrzej Garbacz
Pawel Lukowski
James R. Clifton

August 1999
Building and Fire Research Laboratory
National Institute of Standards and Technology
Gaithersburg, Maryland 20899



U.S. Department of Commerce
William M. Daley, *Secretary*
Technology Administration
Gary R. Bachula, *Acting Under Secretary for Technology*
National Institute of Standards and Technology
Raymond Kammer, *Director*

OUTLINE OF REPORT

EXECUTIVE SUMMARY

ABSTRACT

1. INTRODUCTION
2. FUNDAMENTAL APPROACH
3. OPTIMIZATION METHOD AND STATISTICAL VERIFICATION
 - 3.1 The basic technical characteristics of polymer concrete
 - 3.2 Statistical verification
4. EXPERIMENTAL DESIGN
5. MATERIAL MODEL OF POLYMER CONCRETE AS THE BASIS FOR ITS OPTIMIZATION
6. COMPARATIVE ANALYSIS OF THE MATERIAL MODELS FOR EPOXY AND POLYESTER CONCRETES
 - 6.1 Materials and results
 - 6.2 Summary of material models
7. THE OVERALL DESIRABILITY CONCEPT
8. EXPERIMENTAL VERIFICATION AND APPLICATION OF THE MATERIAL OPTIMIZATION METHOD FOR POLYMER CONCRETE COMPOSITES
 - 8.1 Polyester concrete with silica fume
 - 8.2 Highly-filled polyester concrete
 - 8.3 Epoxy concrete evaluated in terms of low flammability and combustibility
9. SUMMARY
10. REFERENCES
11. NOMENCLATURE

APPENDIX A: PROJECT CONSULTANTS

APPENDIX B: LIST OF PUBLICATIONS ASSOCIATED WITH THE PROJECT

EXECUTIVE SUMMARY

This is the final report for the three-year project entitled Polymer Concrete Composites. The project was sponsored by the Maria Sklodowska-Curie US-Polish Joint Fund II: MEN/NIST-90-44. The project was collaboratively carried out by the National Institute of Standards and Technology (NIST), Gaithersburg, MD, USA and the Institute of Technology and Organization of Building Production (ITOBP), Warsaw University of Technology, Warsaw, Poland. James R. Clifton (NIST) and Lech Czarnecki (ITOBP) were the principal investigators.

The main objective of this project was to establish and validate an approach for developing material models for the material design and optimization of polymer concrete. The design of the experimental program was developed by the principal investigators, and was carried out at the ITOBP laboratories. NIST collaborated in the model development, interpretation of test results, and preparation of reports. The reliability of the approach was demonstrated for epoxy and polyester concrete, in terms of optimization with respect to silica fume addition, high loading of aggregates to reduce polymer binder costs, and flammability and combustibility. The results of the project show how polymer concrete can be optimized for use in the infrastructure.

Cover: Showing (left) a typical polymer concrete microstructure, where the width of the image is approximately 50 mm, and (right) a typical plot of a polymer concrete optimization surface for two independent variables, produced by the program MOS [7].

ABSTRACT

The objective of this project was the development of a method for the design and optimization of polymer concrete composites, using a fundamental approach based on material models of polymer concrete. The important technical properties and the statistical evaluation of the heterogeneity of polymer concrete are presented. Some aspects of the statistical design of experiments are described. It was shown that a material model based on quadratic functions formed a suitable basis for the optimization of polymer concrete. A comparative analysis of the material models of the two main types of polymer concrete, epoxy and polyester concrete, was carried out. Graphical examples of model applications are presented and the conclusions from the analyses are given. The *overall desirability function* was then used as the metric for the multi-criteria optimization of polymer concrete. This optimization process was applied to several particular polymer concrete composites, including polyester concrete with silica fume, highly-filled polyester concrete to reduce material costs, and epoxy concrete of low flammability and combustibility. Experimental validation of the results of the optimization process was carried out. Specific problems were solved using the computer program MOS developed as part of this joint project. The manual for this user-friendly program, which should be a generally useful tool for polymer concrete designers, has been published separately [7].

KEYWORDS

Building technology, combustibility, epoxy resin, flammability, heterogeneity, composite, material design, microfiller, optimization, overall desirability function, polymer concrete, polyester resin, response surfaces, silica fume.

1. INTRODUCTION

Developments in civil engineering and industrial growth have created a continual demand for building materials with new and improved performance attributes [1]. Optimized polymer concretes (PC) appear to offer possibilities for meeting these new requirements [2]. By polymer concrete is meant a polymer composite with a polymer matrix and sand and rocks, like those used in portland cement concrete, as inclusions. Service conditions often dictate specific material requirements that may be met by PC when several composite properties are considered simultaneously. However, because the material cost of PC tends to be high [3], optimization of PC properties is necessary in order to keep the costs as low as possible while still meeting specific material requirements. Understanding of the nature of PC is necessary for the design of the most cost-effective PC composites and to produce materials with desired properties. Until now, the engineer has resolved these problems in a phenomenological way, limiting his consideration to empirically understanding the mechanical and physical behavior. However, in a purely empirical approach, experience gained in one application is often not transferable to other areas. The basic idea of this study is that every application requires specific material properties that can be produced by controlling the material structure [4]. To carry out material design and optimization for PC, one must rely on a material model as a "tool" to control the PC properties [5]. Appropriate concepts for material models and the material optimization method, including synergistic effects between various properties, have been developed. An important use of the material optimization method is then to utilize these synergistic phenomena of polymer composites [6] to meet the needs of specific applications.

This is the final project report, which summarizes and discusses the results of three years of research under the framework of the U.S.-Polish Joint Project. The main partners were the National Institute of Standards and Technology (NIST), Gaithersburg, MD and the Institute of Technology and Organization of Building Production (ITOBP) of the Warsaw University of Technology, Warsaw. James R. Clifton of NIST and Lech Czarnecki of ITOBP were the principal investigators. The project consultants in the program are listed in Appendix A. In the first year, the basic goals of the program and the objectives of the study, as well as the terms and definitions involved with the topic, were determined. In the second year, studies on various material compositions were completed. In the third year, material models were developed for two main groups of polymer composites: epoxy and polyester concrete. Also, a computer program [7], which can be used for the material optimization of polymer concrete, was developed and tested for optimizations involving silica fume, volume fraction of aggregates, and flammability and combustibility. The algorithmic details of this program, along with appropriate

documentation, have been published elsewhere [7]. Several published papers associated with the project are listed in Appendix B.

In this report, first the general principles of the optimization approach are described, along with the experimental design used. Then the material model methodology is introduced, and the material model results given for polyester and epoxy concrete. Finally, the overall desirability function concept is described and used in three case studies of producing polymer concrete optimized for different properties, using different materials.

2. FUNDAMENTAL APPROACH

Running a business can be described as “thriving on chaos.” But progress in production will only be obtained by transforming “chaos” to “order.” Similarly, in producing material composites, progress can only be obtained by transforming the notion of “mixture” to that of “composite.” A mixture is just a simple combination of ingredients, with properties that are a result only of the simple summation of properties of the components. However, a composite is a solid material system consisting of two or more phases with macroscopically distinguishable boundaries among phases, which has properties not attainable by a single component, or by a simple summation of the properties of the components. The purpose of the composite is to obtain properties that are superior to those of the individual constituents. Optimizing overall properties with respect to component properties and proportions is included in the definition of a composite.

The question that remains is how to find the most *cost-effective* way for optimizing suitable polymer concrete mixtures. The idea is to develop a “tailor-made” material for each application. The problem of optimization is complicated because a number of mechanisms in the generation and application of polymer composites can act synergistically, both negatively and positively. Any optimization process must therefore handle these synergisms quantitatively.

3. OPTIMIZATION METHOD AND STATISTICAL VERIFICATION

3.1 The basic technical characteristics of polymer concrete

Polymer concrete is a material which, unlike ordinary portland cement concrete, does not contain an inorganic binder. The binder or matrix in polymer composites is a synthetic resin. According to the resin type used, it is possible to classify polymer concretes as epoxy, polyester, acrylic, polyurethane, etc. The types of polymer concrete most often used in the building industry are epoxy and polyester concrete [8]. The ranges of their properties are given in Table 3.1. The complete nomenclature used in this report is given in Sec. 11.

Polymer concrete is usually used in severe conditions in industrial and public buildings as well as in transportation and hydraulic structures [10]. The main uses are repair, strengthening, and corrosion protection of concrete structures [8]. The main advantages of polymer concrete over ordinary concrete are improved mechanical strength, low permeability, and improved chemical resistance [3, 8, 9]. The main limitation is their relatively high material cost. This is why it is important to find the optimum technical/economic compromise. To solve this problem, it is necessary to formulate a reliable predictive mathematical model of polymer concrete material properties.

Table 3.1. RANGE OF PROPERTIES OF EPOXY AND POLYESTER CONCRETES [3,9]

No	Property	Unit	Epoxy concrete	Polyester concrete
1	Density, d	kg/m ³	1950-2400	2000-2400
2	Linear shrinkage, ε_1	%	0.003-0.05	0.01-0.3
3	Compressive strength, R_c	MPa	50-150	50-150
4	Flexural strength, R_g	MPa	15-50	15-45
5	Tensile strength, R_t	MPa	8-25	8-25
6	Modulus of elasticity in compression, E_c	GPa	20-40	20-40
7	Modulus of elasticity in tension, E_t	GPa	12-15	11-14
8	Brinell hardness, h_B	MPa	250-400	160-250
9	Grindability, g	cm	0.10-0.30	0.10-0.30
10	Poisson's ratio, P	-	0.30	0.16-0.30
11	Linear thermal expansion coefficient, α_T	(1/K) • 10 ⁶	10-35	10-30
12	Adhesion to steel, A_s	MPa	5-14	4-12
13	Adhesion to concrete, A_c	MPa	4-6	4-5
14	Water absorption, W_A	%	0.02-1	0.03-1

3.2. Statistical verification

Polymer concrete is a heterogeneous material. As a result, the properties of polymer concrete may be highly variable. It is therefore necessary to use a statistical approach [11]. Contributions to the variability of the composite material are: heterogeneity of the aggregate particles, polydispersion (distribution of chain lengths) of the polymer binder, and conditions in the aggregate - binder interface

zone, e.g. differences in the development of adhesion forces or in polymer orientation effects.

For the purpose of optimization, it is necessary to evaluate the heterogeneity of the material. It is desirable to be able to predict how the material heterogeneity manifests itself in various properties and how these properties are affected by the major material variables. A major consideration in the research (Fig. 3.1) was the effect of the material heterogeneity on the test results, considering the following experimental variables:

- Aggregate mineral type: basalt, granite, crushed quartzite and quartzite;
- Maximum aggregate size – 2 mm, 4 mm, 8 mm;
- Normal curing method: 21 days under normal conditions (20 °C)
- Accelerated curing method: 1 day at 20 °C, 2 days at 60 °C,
- then 1 day at 20 °C.

Three categories of properties were determined:

- Physical property: density (d);
- Mechanical properties: compressive strength (f_c), flexural strength (f_b) and modulus of elasticity (E);
- Processing parameter: linear shrinkage on curing, (α_l)

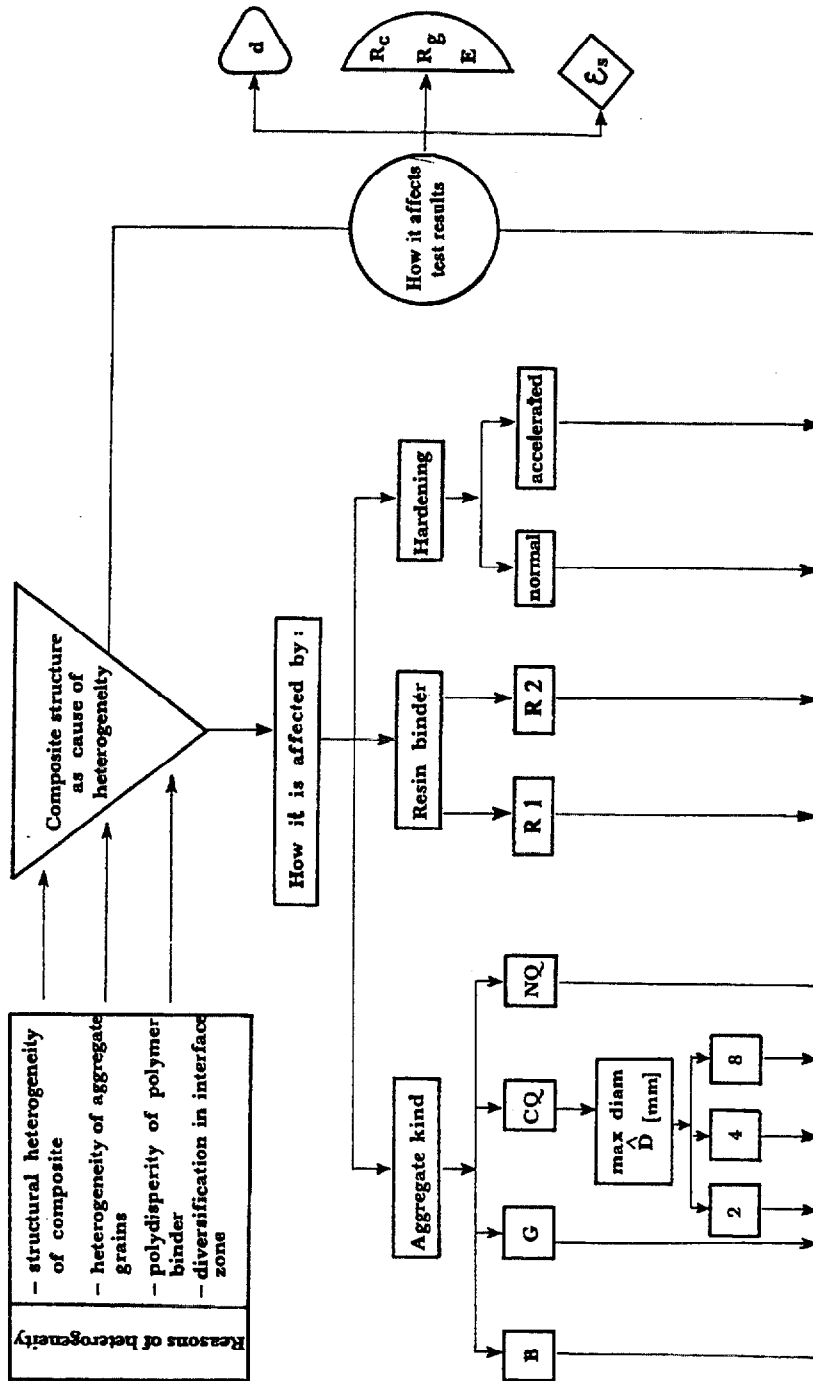

Figure 3.1 Schematic flow chart of the research on the heterogeneity of polymer concretes with various polymer (epoxy) binders. Key: B - basalt, G - granite, CQ - crushed quartzite, NQ - natural quartzite, d - density, R_c - compressive strength, R_g - flexural strength, E - modulus of elasticity, ϵ - linear shrinkage, R1, R2 - commercial epoxy resins (R1=ordinary epoxy resin, R2=low viscosity epoxy resin).

For each concrete mixture, 36 samples were tested in a statistically designed experimental program that is described in Sec. 4. A strong argument in favor of the distribution of experimental properties being normal (Figs. 3.2 and 3.3) or log-normal was provided by the Kolmogorov-Smirnov test. It is also in agreement with data in the literature [12]. A brief summary of the effect of the material heterogeneity on the mechanical properties can be given, based on the test results on these 36 samples. The maximum diameter of the aggregate particles had the largest effect on the mechanical properties. The narrowest compressive strength distribution curve was obtained with the smallest filler particles. By the width of the distribution is meant the standard deviation of the variable being considered. It seems reasonable to assume that, in the case of the load-dependent properties, the variability of properties is to some degree dependent on the macrostructural heterogeneity of the material.

The width of the distribution of the properties is dependent on the kind of aggregate. The distribution of the various properties of the given polymer concretes is manifested in various ways, e.g., for basalt epoxy concrete the compressive strength distribution is narrow, but the distribution of the flexural strength and of the modulus of elasticity is broad.

The curing conditions of the polymer concrete also influence the width of the strength distribution curve. As a rule, the width of the distribution is broader after normal curing than after accelerated curing. The type of epoxy resin had only a slight influence on the shape of the distribution curves.

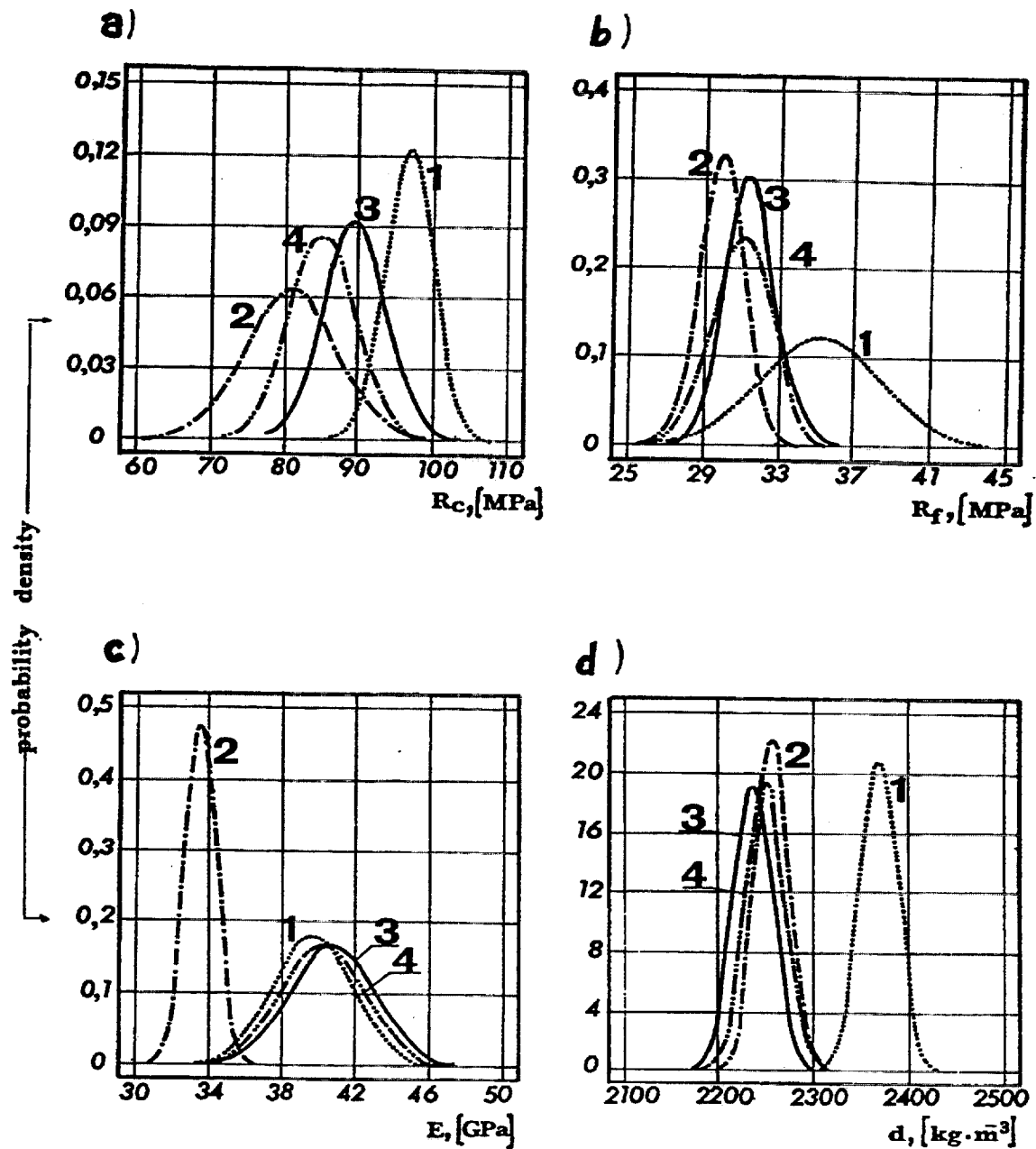

Figure 3.2: Normal distribution of (a) compressive strength, (b) flexural strength, (c) modulus of elasticity, and (d) density, for epoxy concrete. Maximum particle size = 8 mm, accelerated curing. Curve 1 - basalt, curve 2 - granite, curve 3 - crushed quartzite, curve 4 - natural quartzite.

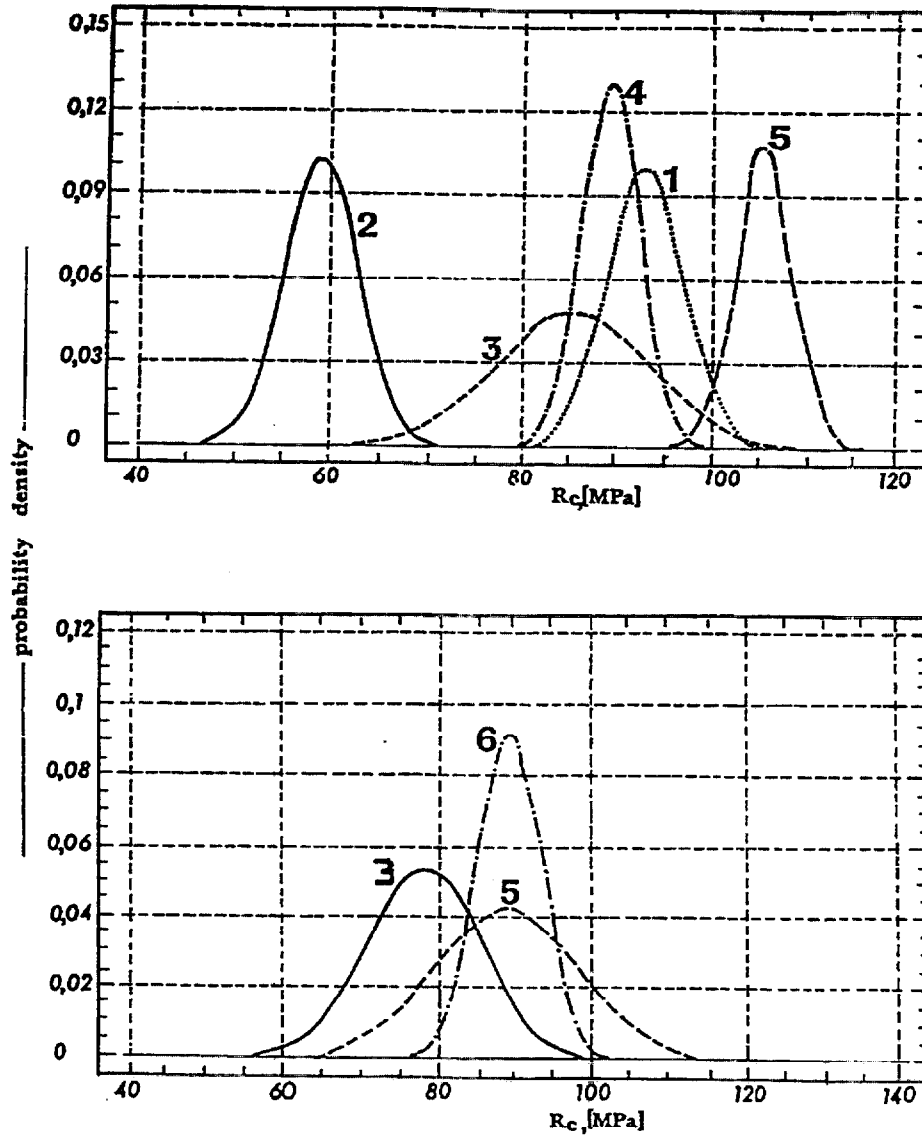

Figure 3.3: Normal distribution of compressive strength of epoxy concrete samples (top - ordinary epoxy, bottom - low viscosity epoxy) cured under various conditions. Maximum grain size = 2 mm-- normal (1) and accelerated (2) curing; maximum grain size = 4 mm-- normal (3) and accelerated (4) curing; maximum grain size = 8 mm-- normal (5) and accelerated (6) curing.

4. EXPERIMENTAL DESIGN

The main advantage of using statistically-designed experiments is the minimization of the number of the tests necessary to obtain the desired information on a material. It may be possible to significantly decrease the number of tests compared to traditional methods, as well as to shorten the experimental period [13, 14]. The results obtained are also more amenable to statistical analysis and the error of the estimates obtained from fitting the test results may be decreased [15] over other methods.

There are many experimental designs, such as simplex-lattice, factorial, and rotatable [16]. The type of design should be selected for the given application. For fitting first- and second-degree models, the rotatable designs are suggested [13], and so have been used in this project.

The rotatable experimental design is based on regression analysis, making possible the formulation of mathematical models and evaluation of their precision. The rotatable design enables a mathematical description of an object of unknown characteristics to be determined on the basis of the testing of the values of the input and output parameters. If the given object is characterized by S input parameters, $X_1, X_2, X_3, \dots, X_S$, and one output parameter, Y , and the object is affected by the random disturbances Z (non-measurable), then the function $Y=f(X_1, \dots, X_S, Z)$ is a stochastic relation. For one set of the independent variables X_1, \dots, X_S , there can be more than one value of Y . The stochastic relation is then approximated by the regression function: $\hat{Y} = f(x_1, \dots, x_S; b_1, \dots, b_k)$, where b_1, \dots, b_k are the unknown coefficients.

The regression function \hat{Y} approximates the real values of the given property, which are in principle non-determinable due to the non-measurable random disturbances Z . The unknown relation is approximated near the center point [16], defined by the values $X_1^0, X_2^0, \dots, X_S^0$, where $X^0 = 1/2 (X_{\max} + X_{\min})$ and X_{\max} is the maximum value of the given design variable in the experiment and X_{\min} is its minimum value. The statistical neighborhood of the center point is determined by the variability ranges $\Delta X_1, \Delta X_2, \dots, \Delta X_S$, where $\Delta X = X_{\max} - X^0 = -(X_{\min} - X^0) = 1/2 (X_{\max} - X_{\min})$. To simplify the calculation procedure, the variables X_1, \dots, X_S are transformed to dimensionless variables x_1, x_2, \dots, x_S . The transformation is based on moving the origin of the coordinate system to the center point, and changing the axis scale, so that $\Delta X_1, \dots, \Delta X_S$ each equal 1, and $-1 \leq x_j \leq 1, j = 1, s$:

$$x_S = \frac{X_S - X_S^0}{\Delta X_S}$$

The regression function for the dimensionless variables has the form:

$$A = a_0x_0 + a_1x_1 + \dots + a_sx_s + a_{11}x_1^2 + \dots + a_{ss}x_s^2 + a_{12}x_1x_2 + \dots + a_{1s}x_1x_s + \dots + a_{s-1,s}x_{s-1}x_s$$

For three variables ($s = 3$), which is the usual case in the testing of polymer concretes, this function becomes:

$$A = a_0 + a_1x_1 + a_2x_2 + a_3x_3 + a_{11}x_1^2 + a_{22}x_2^2 + a_{33}x_3^2 + a_{12}x_1x_2 + a_{13}x_1x_3 + a_{23}x_2x_3.$$

The rotatable second-degree experimental design for three input variables, which was used for developing the material models for the polymer composites, is the Box design [17] with a six-fold repetition of the variable values at the center point $\{x_1 = x_2 = x_3 = 0\}$ (Table 4.1).

Table 4.1: COMPOSITIONAL BOX DESIGN FOR THREE INPUT VARIABLES [17]

No	Value of the coded variable		
	x_1	x_2	x_3
1	0.58	0.58	0.58
2	0.58	0.58	-0.58
3	0.58	-0.58	0.58
4	-0.58	0.58	0.58
5	0.58	-0.58	-0.58
6	-0.58	0.58	-0.58
7	-0.58	-0.58	0.58
8	-0.58	-0.58	-0.58
9	0.97	0	0
10	-0.97	0	0
11	0	0.97	0
12	0	-0.97	0
13	0	0	0.97
14	0	0	-0.97
15	0	0	0
16	0	0	0
17	0	0	0
18	0	0	0
19	0	0	0
20	0	0	0

5. MATERIAL MODEL OF POLYMER CONCRETE AS THE BASIS FOR ITS OPTIMIZATION

Understanding of the nature of polymer concrete is needed in order to rationally design and fabricate the most cost-effective composite material. In particular, a mathematical model of polymer concrete properties based on materials parameters like the volume fractions and properties of the components is needed, which can be used to predict physical and mechanical behavior. This kind of model will be called a material model, which is to be understood as a “components - properties” relationship [5], part of the material science triad of components, structure, and properties. Several ways of formulating such a model are available.

One way to define and build a material model would be by using experimental and statistical methods [18]. One fits the experimental data with mathematical equations, which then gives predictive power for materials parameters that were not used in the original measurements, as long as these parameters are not too different from those that were measured. This was the method used in this project, based on the statistical experimental design discussed in Sec. 4.

A second approach, however, would be the formulation of the model as an interaction of external forces and the properties of the components, along with a knowledge of the general mechanisms behind the composite properties [19], and a detailed knowledge of the macro- and microstructures of the composite. This would be a more fundamental approach than the statistical method. However, the current level of understanding of composite materials is still not sufficient for use of this fundamental approach.

To build a material model of the first kind, the values of the material design variables are selected and the values of the tested features are measured. A mathematical form is fit between the inputs and outputs, which then becomes the material model. How useful this model will be for optimization studies depends on the variability range of the input parameters, i.e., how much variability is allowed for the model to still be accurate, and - most importantly - on the method of selecting the reference points. The reference points are the values of the material design variables at which tests have been made. Often this selection is only based on the intuition of the researcher. If the model contains only one variable, such an intuitive method can be reasonable. In the case of a greater number of variables, a multi-factorial optimization scheme is required, with the experiments carried out according to a statistical design method. Results from a statistical experimental design should produce regression functions of acceptably high correlation coefficients. This is the route that has been followed.

The experimental and statistical method used here is a compromise between simplicity and accuracy. It is hoped that even such a model will significantly improve the basis for design and optimization of polymer concrete [20].

6. COMPARATIVE ANALYSIS OF THE MATERIAL MODELS OF EPOXY AND POLYESTER CONCRETES

6.1 Materials and results

The starting point for development of the material models of epoxy and polyester concrete was the results of experiments performed in the Building Polymer Composites Laboratory of Warsaw University of Technology. The experiments were carried out, using the rotatable experimental design, for eight polymer composites: four epoxy and four polyester concrete types as shown in Table 6.1. Note that the material parameters have been made into dimensionless ratios like the filler binder mass ratio, F/B , etc. These dimensionless variables have then been transformed, as described in Sec. 4, to lie between -1 and 1 . These variables are used for Figs. 6.1-6.8.

Regression and correlation analyses were then performed on the results of these tests. Quadratic functions were used as the basis of the models, as was previously defined. The next step was finding, also by computation, the optimal points and the values of specific properties. The results of the calculations are graphically presented in the form of space figures, and also as two-dimensional sections (isolines), showing the variation of the property of interest in a contour plot. The space figures show the response surfaces for various material properties (density, compressive strength, modulus of elasticity, etc.) for the various polymer concrete types (see Figs. 6.1-6.8), as a function of two of the three materials design variables used. Because it is only possible to present two of the three material design variables in the same graph, the third variable was treated as a constant and set equal to its optimal value (the value at which the property of interest was extremized). But each figure has three parts, where each part uses two of the three possible material design variables as coordinate axes, so relatively complete information on the actually four-dimensional response surface is given. The isoline graphs have the same axes as the space figure next to them. Figures 6.1-6.4 are for epoxy concrete materials, while Figs. 6.5-6.8 are for polyester concrete materials.

Table 6.1: POLYMER COMPOSITES TESTED

No	Material	Material variables	Variability range	Determined properties
1	Epoxy concrete with basalt aggregate	Filler/Binder, F/B Microfiller/Filler, M/F Sand/Filler, S/F	8-13 0.06-0.21 0.17-0.60	Flexural strength R_g Compressive strength, R_c Modulus of elasticity, E Density, d
2	Epoxy concrete with granite aggregate	Filler/Binder, F/B Microfiller/Filler, M/F Sand/Filler, S/F	8-13 0.015-0.125 0.08-0.70	Flexural strength R_g Compressive strength, R_c Modulus of elasticity, E Density, d
3	Epoxy concrete with crushed quartzite aggregate	Filler/Binder, F/B Microfiller/Filler, M/F Sand/Filler, S/F	8-13 0.07-0.25 0.17-0.60	Flexural strength, R_g Compressive strength, R_c Modulus of elasticity, E Density, d
4	Epoxy concrete with natural quartzite aggregate	Filler/Binder, F/B Microfiller/Filler, M/F Sand/Filler, S/F	8-13 0.04-0.21 0.12-0.60	Flexural strength, R_g Compressive strength, R_c Modulus of elasticity, E Density, d
5	Polyester concrete with natural quartzite aggregate	Filler/Binder, F/B Microfiller/Filler, M/F Sand/Filler, S/F	6-10 0.10-0.30 0.20-0.40	Flexural strength, R_g Compressive strength, R_c Modulus of elasticity, E Density, d
6	Polyester concrete cured at low temperature (-10°C)	Benzoyl peroxide content, BP Dimethylaniline content, DMA Aluminosilicate content, Z4A	0.5-4.0 0.3-2.0 0-30	Compressive strength, R_c Curing time, t
7	Polyester concrete with silica fume	Filler/Binder, F/B Microfiller/Filler, M/F Silica fume/Microfiller, Sf/M	2.5-6.0 0.0-0.25 0.2-1.0	Flexural strength R_g Compressive strength, R_c Modulus of elasticity, E
8	Highly-filled polyester concrete	Filler/Binder, F/B Silane content, Sil Binder/Microfiller, B/M	20-30 0.1-0.9 10-100	Flexural strength, R_g Compressive strength, R_c Water absorption, W_a

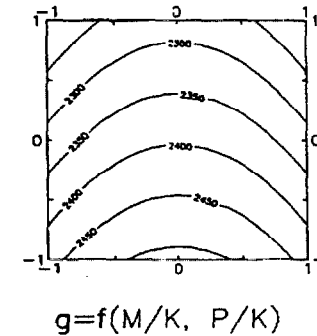
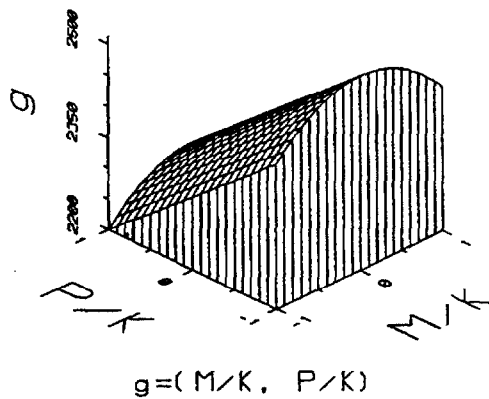
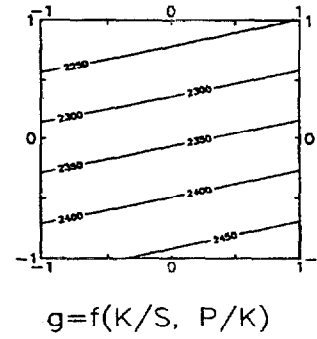
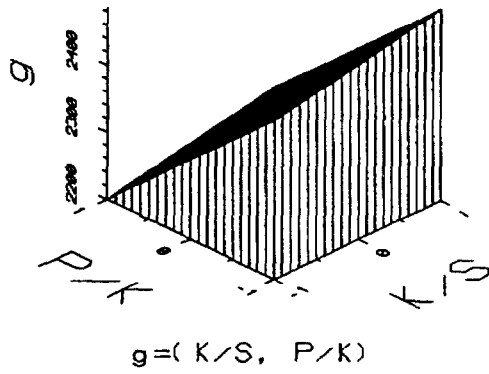
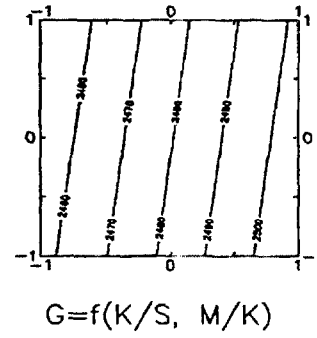
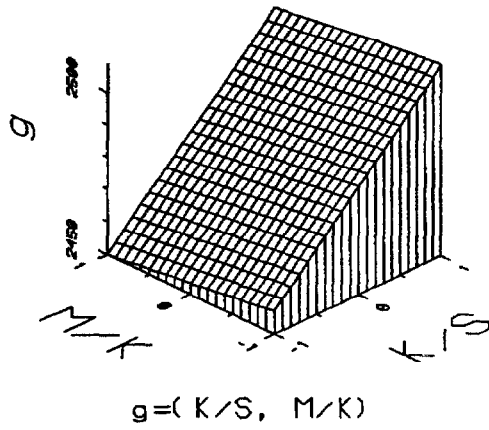

Figure 6.1: Epoxy concrete with the basalt aggregate, showing the density (d) = $g(\dots)$ as a function of the material variables: K - aggregate, S - resin binder, M - microfiller, P - sand.

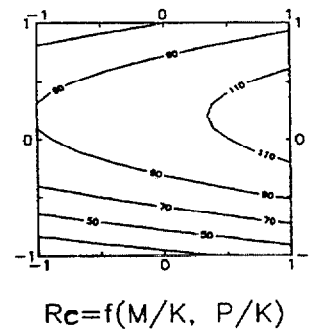
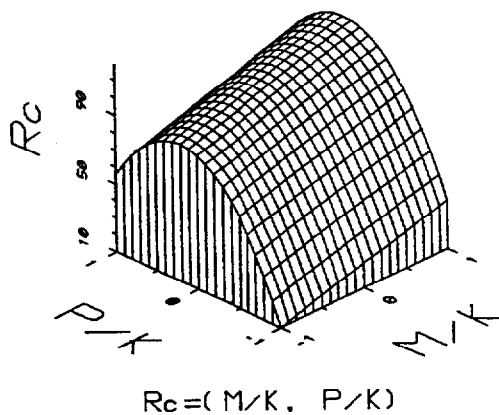
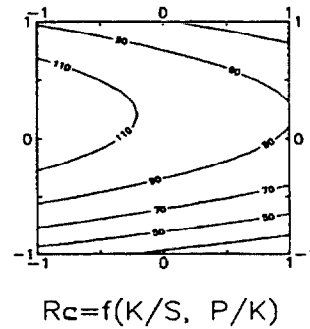
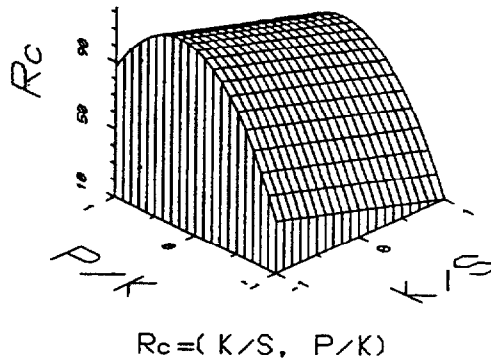
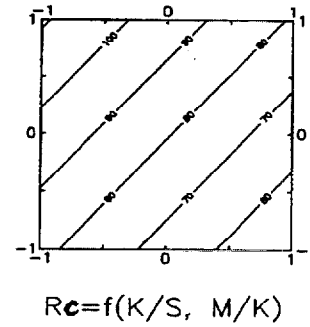
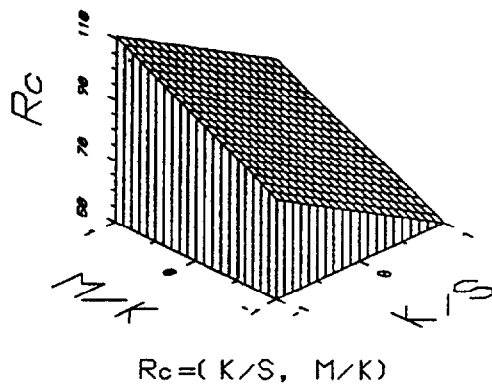

Figure 6.2: Epoxy concrete with the granite aggregate, showing the compressive strength (R_c) as a function of the material variables: K - aggregate, S - resin binder, M - microfiller, P - sand.

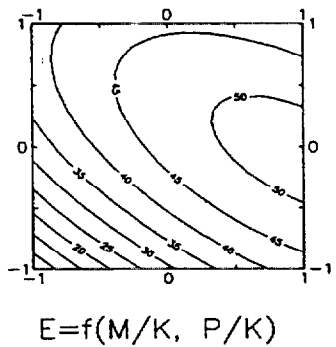
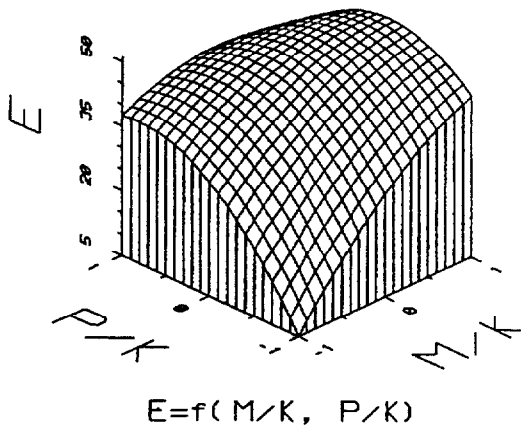
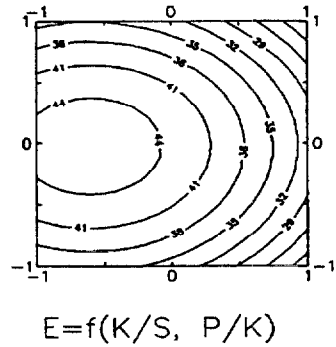
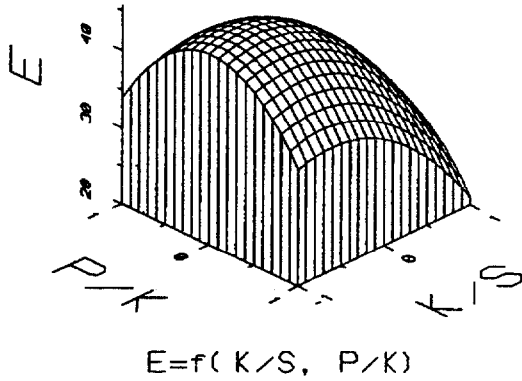
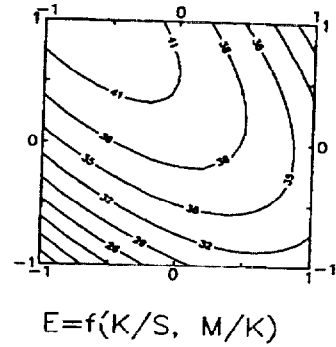
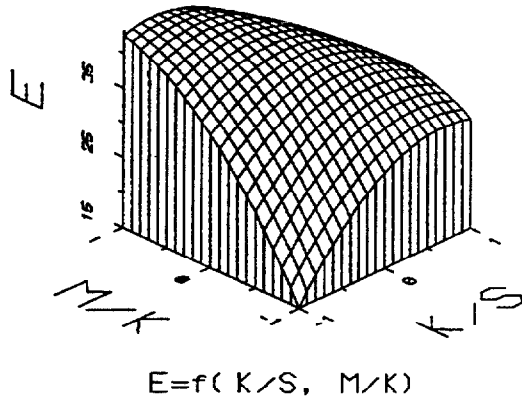

Figure 6.3: Epoxy concrete with the crushed quartzite aggregate, showing the modulus of elasticity (E) as a function of the material variables: K - aggregate, S - resin binder, M - microfiller, P - sand.

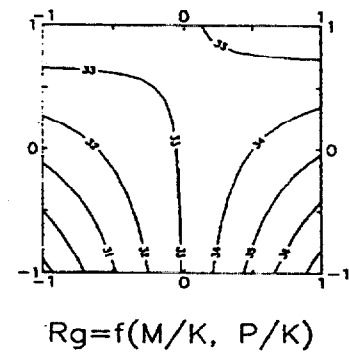
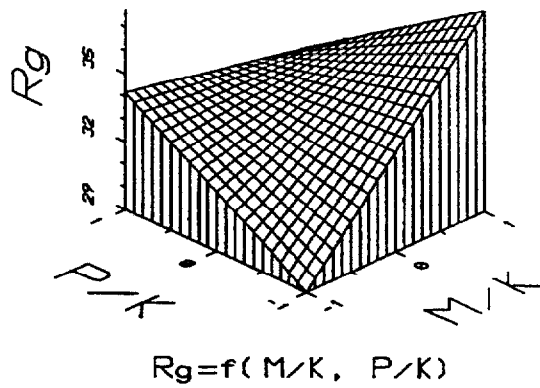
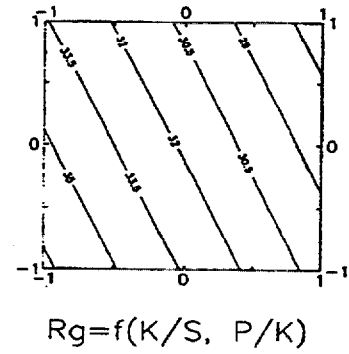
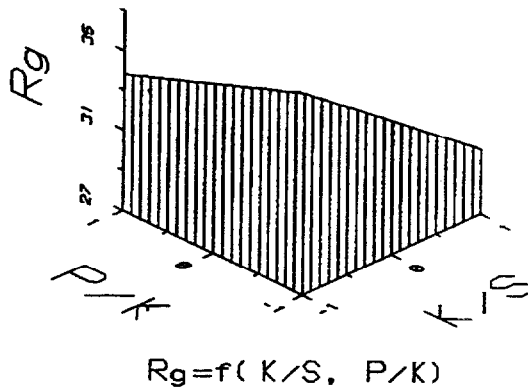
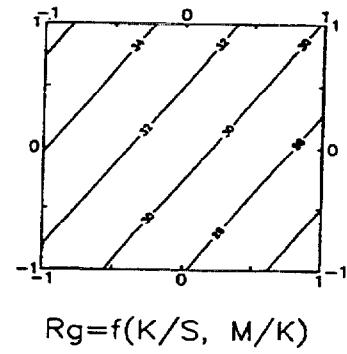
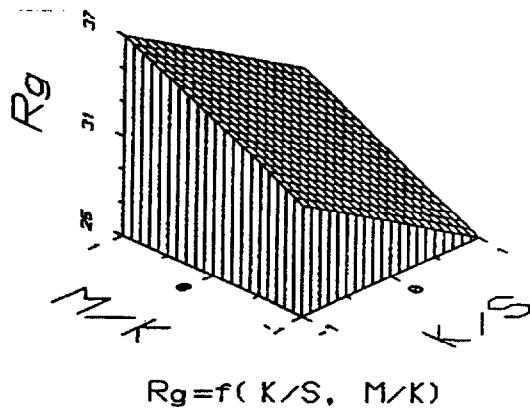

Figure 6.4: Epoxy concrete with the natural quartzite aggregate; flexural strength (R_g) as a function of the coded material variables; K - aggregate, S - resin binder, M - microfiller, P - sand

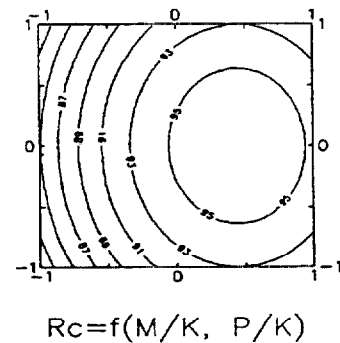
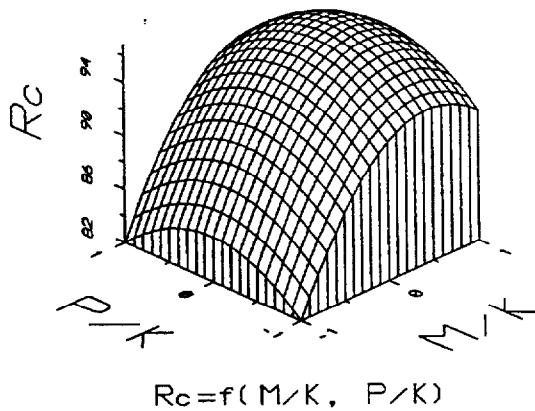
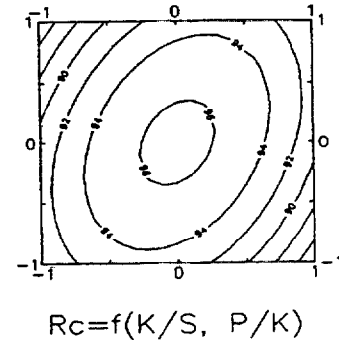
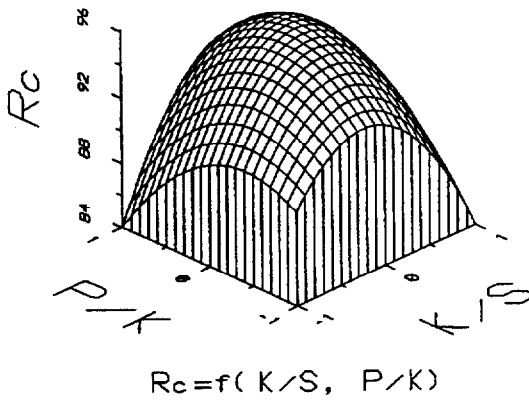
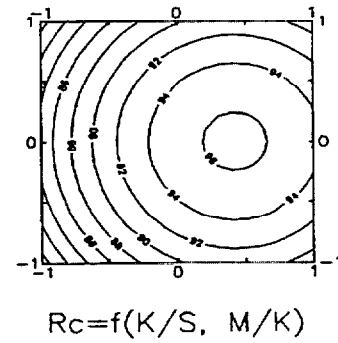
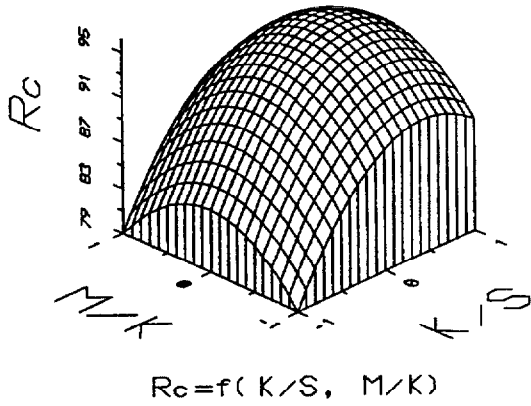

Figure 6.5: Polyester concrete with the natural quartzite aggregate, showing the compressive strength (R_c) as a function of the material variables: K - aggregate, S - resin binder, M - microfiller, P - sand.

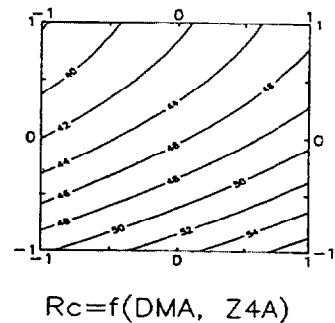
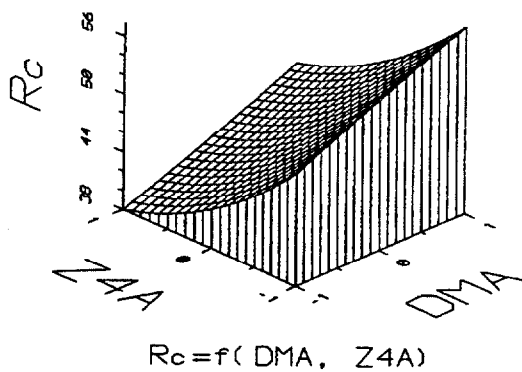
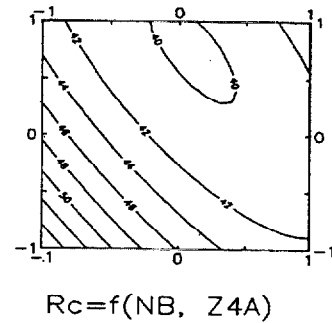
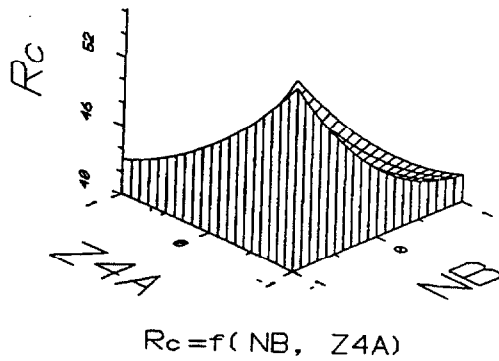
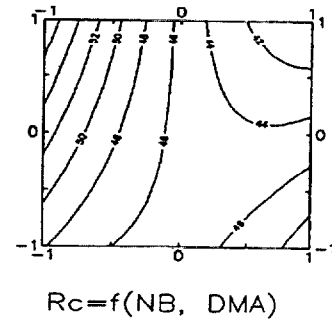
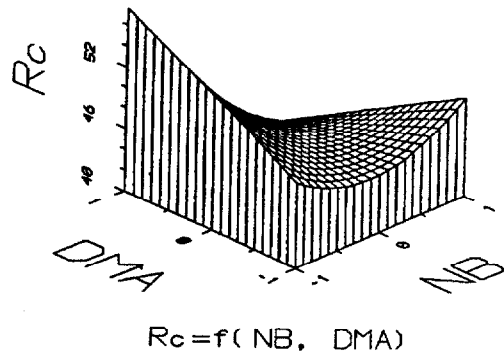

Figure 6.6: Polyester concrete, low temperature cure (-10°C), showing the compressive strength (R_c) as a function of the material variables: NB - benzoyl peroxide, DMA - dimethylaniline, Z4A - aluminosilicate.

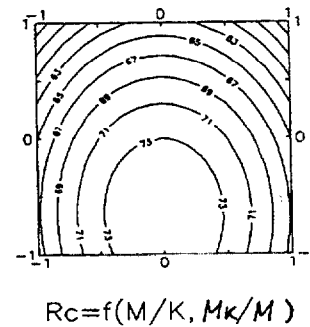
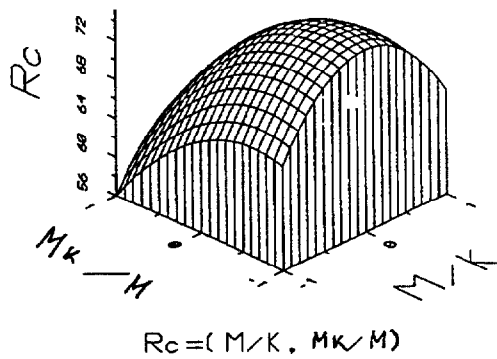
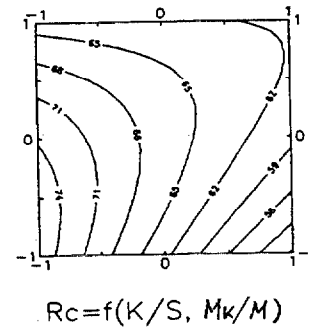
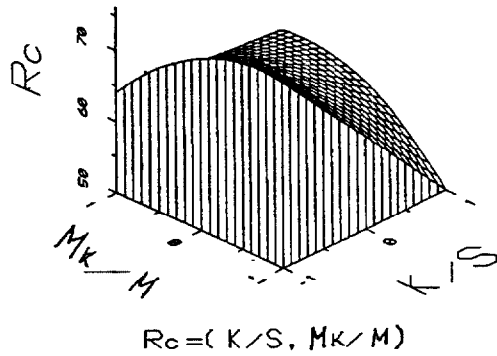
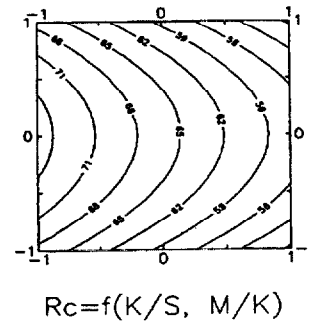
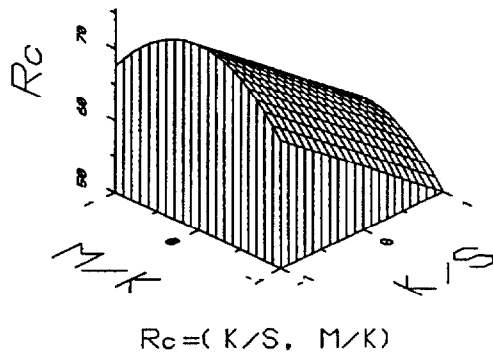

Figure 6.7: Polyester concrete with silica fume, showing the compressive strength (R_c) as a function of the material variables: K - aggregate, S - resin binder, M - combined microfiller content (silica fume plus quartz meal), M_k - silica fume.

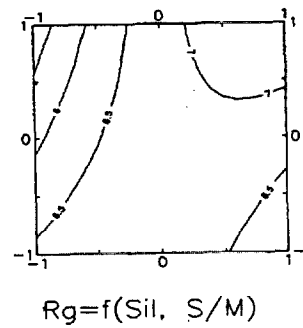
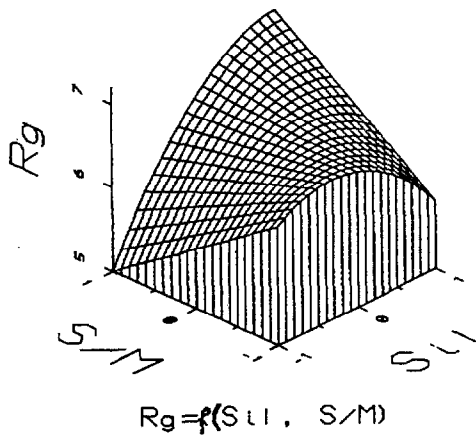
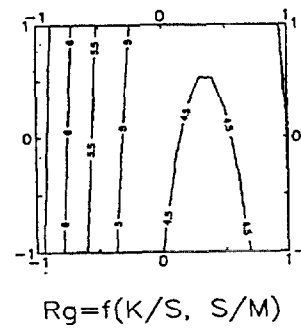
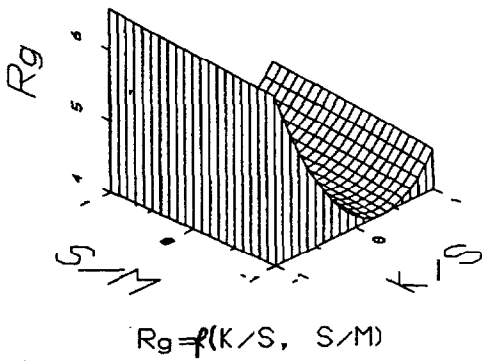
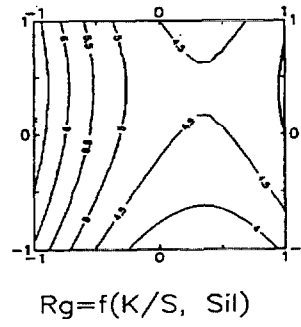
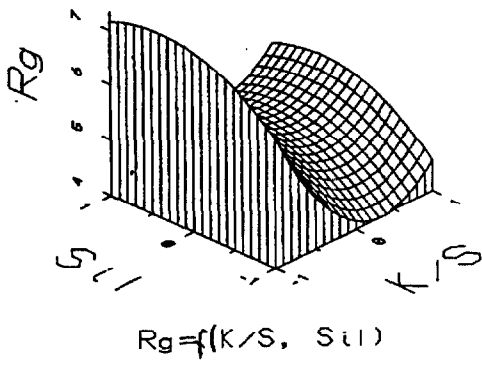

Figure 6.8: Highly-filled polyester concrete, showing the flexural strength (R_g) as a function of the material variables: K - aggregate, S - resin binder, M - microfiller, Sil - silane.

6.2 Summary of material models

The results of the regression calculations for the coefficients of the quadratic functions [4, 5] are given in Table 6.2. On the basis of the analyses, it appears that quadratic function material models of polymer concretes can give reliable predictions. The high degree of fit to the experimental data is confirmed by the high (above 0.85, usually above 0.90) correlation coefficients of the regression functions. Again it is emphasized that the statistical design of the tests made possible this high precision regression fitting. The "mixed" elements (x_1x_2 , x_1x_3 , x_2x_3) represent material parameter interactions. The fact that the coefficients of these elements are not negligible confirms the non-additive, synergistic character of the considered relations. If these quadratic elements were not necessary, the shape of the response surfaces would be planar, not curved as in Figs. 6.1-6.8.

Table 6.2 RESULTS OF CALCULATIONS - MATERIAL MODELS

No	Composite	Standardized (-1; 1) material variables	Regression functions for properties investigated	Correlation coefficient	Optimal point	Optimal value
1	Epoxy concrete with basalt aggregate	$x_1 = F/B$ $x_2 = M/F$ $x_3 = S/F$	$R_g = 34.8 - 3.2x_1 - 1.9x_2 - 1.2x_1x_1 - 2.3x_1x_2$	0.95	$x_1 = -1$ F/B=8 $x_2 = 0.2$ M/F=0.15 x_3 insignificant	36.9 MPa
			$R_c = 98.1 - 6.6x_1 + 2.8x_2$	0.85	$x_1 = -0.9$ F/B=8.25 $x_2 = 0.4$ M/F=0.165 x_3 insignificant	112.6 MPa
			$E = 38.8 + 5x_1 - 1.9x_2x_2 - 3x_3x_3$	0.85	$x_1 = 1$ F/B=13 $x_2 = 0$ M/F=0.075 $x_3 = 0$ S/F=0.385	43.8 GPa
			$d = 2365.5 + 26x_1 - 117x_3 - 79x_2x_2$	0.91	$x_1 = 0.2$ F/B=11 $x_2 = 0$ M/F=0.075 $x_3 = -1$ S/F=0.17	2490 kg/m ³
2	Epoxy concrete with granite aggregate	$x_1 = F/B$ $x_2 = M/F$ $x_3 = S/F$	$R_g = 28.8 - 2.8x_1 + 10.8x_3 - 8.8x_3x_3 - 5.9x_2x_3$	0.94	$x_1 = -0.5$ F/B=9.25 $x_2 = -0.6$ M/F=0.11 $x_3 = 0.2$ S/F=0.45	35.6 MPa
			$R_c = 81.4 - 16.1x_1 + 14.3x_2 + 22.8x_3 - 55.8x_3x_3$	0.89	$x_1 = -0.7$ F/B=8.75 $x_2 = 0.7$ MF=0.11 $x_3 = 0.2$ S/F=0.45	105.0 MPa
			$E = 33.6 + 5.8x_2 + 10.8x_3 - 5.2x_1x_1 - 12.6x_3x_3$	0.95	$x_1 = 0$ F/B=10.5 $x_2 = 0.9$ M/F=0.20 $x_3 = 0.3$ S/F=0.48	40.9 GPa
			$D = 2242 + 28x_2 + 41x_3 - 162x_3x_3 - 71x_2x_3$	0.91	x_1 insignificant $x_2 = 1$ M/F=0.125 $x_3 = 0.1$ S/F=0.36	2270 kg/m ³

Table 6.2 Continued

No	Composite	Standardized (-1; 1) material variables	Regression functions for properties investigated	Correlation coefficient	Optimal point	Optimal value
3	Epoxy concrete with crushed quartzite aggregate	$x_1 = F/B$ $x_2 = M/F$ $x_3 = S/F$	$R_g = 30.4 - 3.7x_1 + 4.1x_3 - 7.3x_3x_3 - 7.2x_2x_3$	0.85	$x_1 = -0.7$ F/B = 8.75 $x_2 = -0.6$ M/F = 0.11 $x_3 = 0.4$ S/F = 0.47	35.2 MPa
			$R_c = 88.5 + 9.3x_2 + 16.5x_3 - 28x_3x_3 - 31.5x_2x_3$	0.86	x_1 insignificant $x_2 = 1$ M/F = 0.25 $x_3 = -0.2$ S/F = 0.34	99.7 MPa
			$E = 41.3 + 6x_2 + 7.4x_3 - 5.8x_1x_1 - 5.2x_2x_2 - 10.3x_3x_3 - 7.8x_1x_2 - 8.8x_2x_3$	0.94	$x_1 = -0.5$ F/B = 9.25 $x_2 = 0.9$ M/F = 0.24 $x_3 = 0$ S/F = 0.385	44.5 GPa
			$d = 2236 + 36x_1 - 28x_3 - 40x_3x_3 + 33x_1x_3$	0.85	$x_1 = 1$ F/B = 13 x_2 insignificant $x_3 = 0$ S/F = 0.385	2270 kg/m ³
4	Epoxy concrete with natural quartzite aggregate	$x_1 = F/B$ $x_2 = M/F$ $x_3 = S/F$	$R_g = 30.7 - 3.4x_1 + 1.8x_2 - 2.6x_2x_3$	0.86	$x_1 = -0.7$ F/B = 8.75 $x_2 = 0.6$ M/F = 0.18 $x_3 = -0.3$ S/F = 0.29	34.6 MPa
			$R_c = 93.8 - 6.4x_1 + 6.5x_{11} - 15.1x_2x_2 - 14x_3x_3$	0.88	$x_1 = -1$ F/B = 8 $x_2 = 0$ M/F = 0.125 $x_3 = 0$ S/F = 0.36	106.7 MPa
			$E = 42.6 + 6.8x_1 + 4.2x_2 - 4.4x_3 - 7.9x_1x_3$	0.85	$x_1 = 0.7$ F/B = 12.25 $x_2 = 0.3$ M/F = 0.15 $x_3 = -0.6$ S/F = 0.22	54.6 GPa
			$d = 2256 + 38x_1 - 100x_3$	0.92	$x_1 = 0.4$ F/B = 11.5 x_2 insignificant $x_3 = -0.9$ S/F = 0.14	2360 kg/m ³

Table 6.2 cont.

No	Composite	Standardized (-1; 1) material variables	Regression functions for properties investigated	Correlation coefficient	Optimal point	Optimal value
5	Polyester concrete with natural quartzite aggregate	$x_1 = F/B$ $x_2 = M/F$ $x_3 = S/F$	$R_g = 30.1 - 1.2x_1 + 0.7x_2 + 0.6x_1x_1 - 0.5x_2x_2 + 0.8x_3x_3$	0.87	$x_1 = -1.0$ F/B = 6 $x_2 = 0.2$ M/F = 0.22 $x_3 = 0.0$ S/F = 0.30	32.0 MPa
			$R_c = 95.3 + 4.9x_2 - 5.8x_1x_1 - 5.5x_2x_2 - 3.4x_3x_3 + 2.9x_1x_3$	0.94	$x_1 = 0$ F/B=8 $x_2 = 0.4$ M/F=0.24 $x_3 = 0$ S/F=0.30	96.4 MPa
			$E = 31.7 + 3.4x_1 - 1.2x_2 + 1x_3 + 1x_1x_1$	0.94	$x_1 = 0.9$ F/B = 9.8 $x_2 = -0.3$ M/F = 0.17 $x_3 = 0.4$ S/F = 0.34	36.3 GPa
			$d = 2303 + 22.5x_1 - 9x_1x_1 - 11x_2x_2 - 11x_3x_3$	0.97	$x_1 = 1$ F/B = 10 $x_2 = 0$ M/F=0.20 $x_3 = 0$ S/F = 0.30	2315 kg/m ³
6	Polyester concrete, low temperature (-10°C)	$x_1 = P/B$ $x_2 = DMA$ $x_3 = Z4A$	$R_c = 42.1 - 1.9x_1 - 3x_3 + 3.3x_1x_1 + 1.8x_3x_3 - 4.7x_1x_2 + 3.6x_1x_3$	0.84	$x_1 = -0.8$ F/B=0.85 $x_2 = 0.3$ DMA=1.4 $x_3 = -0.6$ Z4A=6	51.0 MPa
			$t = 85 - 53x_1 - 51x_2 - 20x_3 + 15x_2x_2 + 22x_1x_2 + 24x_2x_3$	0.84	$x_1 = -0.9$ PB = 3.8 $x_2 = 0.3$ DMA=0.4 $x_3 = 0.25$ Z4A=18.75	26 min.

Table 6.2 cont.

No	Composite	Standardized (-1; 1) material variables	Regression functions for properties investigated	Correlation coefficient	Optimal point	Optimal value
7	Polyester concrete with silica fume	$x_1 = F/B$ $x_2 = M/F$ $x_3 = Mk/F$	$R_g = 28.9 - 2.2x_1 - 1.6x_3 - 1.7x_1x_1 - 2.3x_2x_2 - 4.7x_3x_3$	0.85	$x_1 = 0.6$ $F/B = 3.2$ $x_2 = 0$ $M/F = 0.125$ $x_3 = 0.2$ $Sf/F = 0.5$	29.7 MPa
			$R_c = 66.7 - 7x_1 - 8x_2x_2 - 4.1x_3x_3 + 6x_1x_3$	0.84	$x_1 = -0.9$ $F/B = 2.7$ $x_2 = 0$ $M/F = 0.125$ $x_3 = 0.6$ $Sf/F = 0.8$	74.3 MPa
			$E = 30.9 + 4.2x_1 - 1.8x_1x_1 + 2.8x_1x_3$	0.86	$x_1 = 0.8$ $F/B = 5.65$ x_2 insignificant $x_3 = 0.6$ $Sf/F = 0.8$	34.5 GPa
8	Highly-filled polyester concrete	$x_1 = F/B$ $x_2 = Sil$ $x_3 = B/M$	$R_g = 4.6 - 0.9x_1 + 0.4x_2 + 1.3x_1x_1 - 0.5x_2x_2 + 0.7x_2x_3$	0.95	$x_1 = -1$ $F/B = 20$ $x_2 = 0.1$ $DMA = 0.5$ $x_3 = 0$ $B/M = 0.55$	6.8 MPa
			$R_c = 8.8 - 2.6x_1 + 4.6x_1x_1$	0.92	$x_1 = -1$ $F/B = 20$ x_2 insignificant x_3 insignificant	16.0 MPa
			$Wa = 7 + 0.4x_1 - 1x_2 - 1.2x_1x_1 + 0.9x_2x_2 + 3.4x_3x_3 + 1.2x_1x_3$	0.93	$x_1 = -1$ $F/B = 20$ $x_2 = 0.2$ $Sil = 0.6$ $x_3 = 0.1$ $B/M = 59.5$	5.15%

7. OVERALL DESIRABILITY CONCEPT

An effective and flexible procedure for multi-criteria optimization [21] is the desirability function approach, which was originally developed for process optimization by Harrington [22]. The use of this function enables the evaluation of the composite with respect to the whole set of its properties and takes into consideration specific requirements related to the application of the material [4, 23]. For each criterion y , two values, y_{worse} and y_{better} , should be chosen. Material properties are satisfactory if y takes on values between y_{worse} and y_{better} . The value y_{worse} separates acceptable values of y from non-acceptable ones. The value y_{better} separates good values of y from excellent ones. If the criterion y is optimized in the direction of a maximum, then y_{worse} is less than y_{better} . The function

$$d(y) = (y - y_{\text{worse}}) / (y_{\text{better}} - y_{\text{worse}})$$

transforms the values of the criterion y into a normalized desirability scale. Because $d(y_{\text{worse}})=0$ and $d(y_{\text{better}}) = 1$, $0 \leq d \leq 1$ corresponds to the interval that can be defined as satisfactory. However, it is convenient to express the value of desirability in a scale lying inside the range (0, 1), for which the following equation can be used:

$$H(d) = \exp(-\exp(-d)).$$

Now, the range of satisfactory values of the criterion is transformed (see Fig. 7.1) into the interval (0.37, 0.69), where 0 corresponds to 0.37, and 1 corresponds to 0.69. The individual desirability functions for the particular criteria can be combined into a single criterion by the overall desirability function

$$D(y_1, \dots, y_k) = H(d(y_1))^{w_1} \cdot \dots \cdot H(d(y_k))^{w_k}$$

where w_1, \dots, w_k are the weights related to criteria y_1, \dots, y_k , and $\sum w_i = 1$. The weights are introduced empirically according to the lessons of experience learned from various applications.

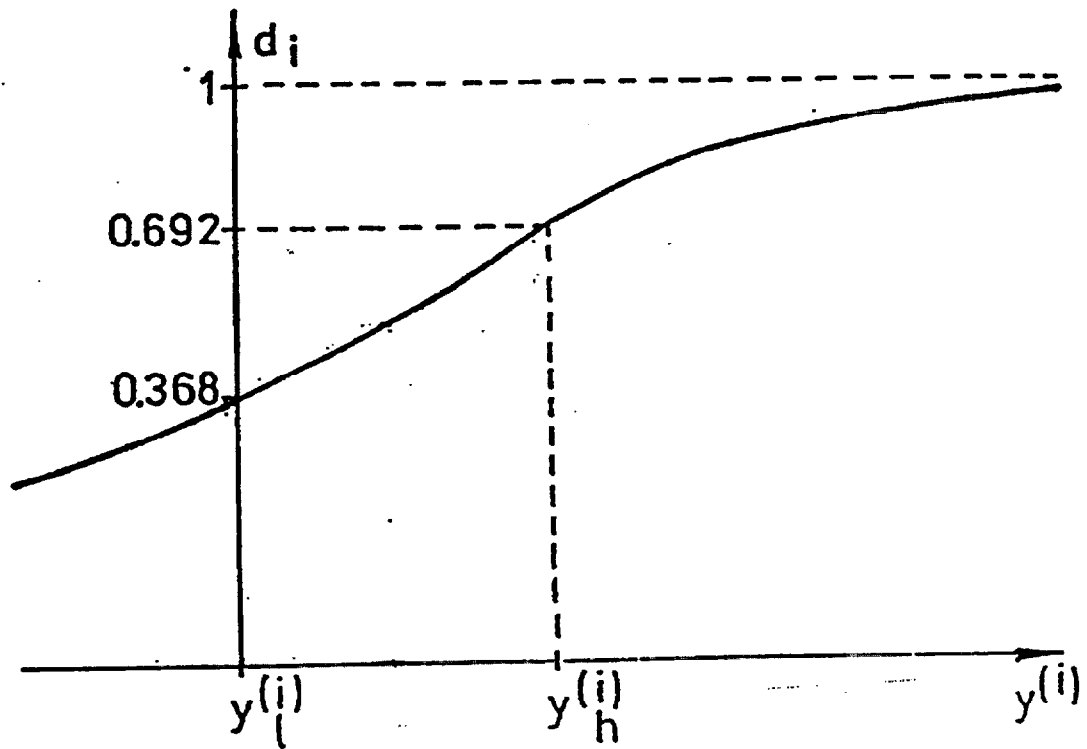

Figure 7.1: Desirability function. d_i – desirability of the given feature (1 = maximal value in the exponential scale), $y^{(i)}$ – value of the feature, $y_l^{(i)}$ – lower limit of the satisfactory interval of $y^{(i)}$, $y_h^{(i)}$ – upper limit of the satisfactory interval of $y^{(i)}$. The desirability function transforms the satisfactory interval (0,1) to the interval (0.368, 0.692).

8. EXPERIMENTAL VERIFICATION AND APPLICATION OF MATERIAL DESIGN AND OPTIMIZATION METHOD FOR POLYMER CONCRETE COMPOSITES

Using the material models discussed in Sec. 6, and the method of multi-criteria optimization [24] using the overall desirability function, as described in Sec. 7, several optimizations of polymer concrete were carried out, on both epoxy and polyester concrete. Three studies are presented in Sec. 8 on three areas of physical interest. The first was to see if silica fume could be used to significantly modify the properties of polyester concrete. The second was to use the optimization method to try and see if an inexpensive, highly-filled polyester concrete could be made that did not sacrifice physical properties of interest. The third case was to see if an epoxy concrete could be made of low flammability, as high flammability usually restricts the use of polymer concrete.

In all these studies, the aim was to produce a polymer concrete material that had a certain desired property, that could be made without sacrificing other properties of importance. That is why the multi-criteria nature of the optimizations was important, as no one variable was to be optimized without taking into consideration the other variables.

In all cases, the MOS [7] program was run first to determine the optimal materials. Tests were then carried out to verify the predictions of the optimization process. These predictions were verified in all cases studied, demonstrating the validity and accuracy of the MOS program. Additional tests were made on the optimized materials to determine if other physical properties (i.e., workability in the uncured state, susceptibility to dusting after hardening, abrasion resistance, etc.) remained within acceptable limits for the optimized materials. The details of all these tests may be found in Refs. [25,27,28], and are not given here.

Three different weight sets were chosen (as described in Sec. 7) to define the overall desirability function in terms of the chosen material design variables. The weights were chosen according to the relative importance of the material design variables, and then somewhat varied, in order to derive several different sets [25,27,28]. Three different sets were chosen in order to test the capabilities of the MOS program, and also to see how much the actual values of the weights mattered to the optimization process. In the three cases described in this report, each weight set gave similar results. Results for all weight sets are given for the sake of completeness.

The graphs of Sec. 8 are in pairs. First a space figure, showing the desirability function plotted against two material design variables, is shown, with an accompanying isoline graph having the same axes in the plane but showing contours of the desirability function. Then the next graph shows essentially the same space figure, but done using the MOS [7] program, in order to illustrate the

kinds of output the program produces. Sometimes the MOS-produced graph has different axes than the preceding space figure, in order to show different aspects of the spatial characteristics of the overall desirability function.

8.1. Polyester concrete modified by silica fume

The aim of this part of the research program was to determine the feasibility of modifying the performance of polyester concrete by incorporating condensed silica fume [25]. Silica fume is a product of condensation of silica from the emissions from the melting of ferrosilicon in electric furnaces. The silica fume, often called "microsilica," is frequently used as a valuable mineral admixture improving the performance of portland cement concrete [26]. Its effects on the properties of polymer concrete, however, have not been previously determined.

The filler-to-binder ratio (X_1), the relative content of microfiller (X_2), and the relative content of the silica fume (X_3) were the material variables used in the optimization. The compressive strength, flexural strength, modulus of elasticity, and water absorption were initially proposed to be used as indicators of performance in the overall desirability function, weighted in various ways (see Sec. 7). However, it was found that water absorption did not distinguish between materials, so it was dropped as an indicator of performance, and only the first three were retained and optimized (see Table 8.1). Three sets of these weights were selected (Table 8.1) and used to compute the maximum value of the overall desirability function. The results are presented numerically in Table 8.2, and are presented graphically in Figs. 8.1, 8.3, and 8.5. Figs. 8.2, 8.4, and 8.6 show the overall desirability function graphs as would be seen in an actual run of the program MOS [7], which was used to determine the data for all the graphs. The overall desirability function is labelled as D_n in Figs. 8.1, 8.3, and 8.5, where $n=1,2,3$, corresponding to the various weight sets.

Table 8.1. OVERALL DESIRABILITY FUNCTION WEIGHTS FOR POLYESTER CONCRETE

Concrete Property	Weight Set		
	I	II	III
Compressive strength	0.33	0.25	0.30
Flexural strength	0.33	0.25	0.40
Modulus of elasticity	0.34	0.50	0.30

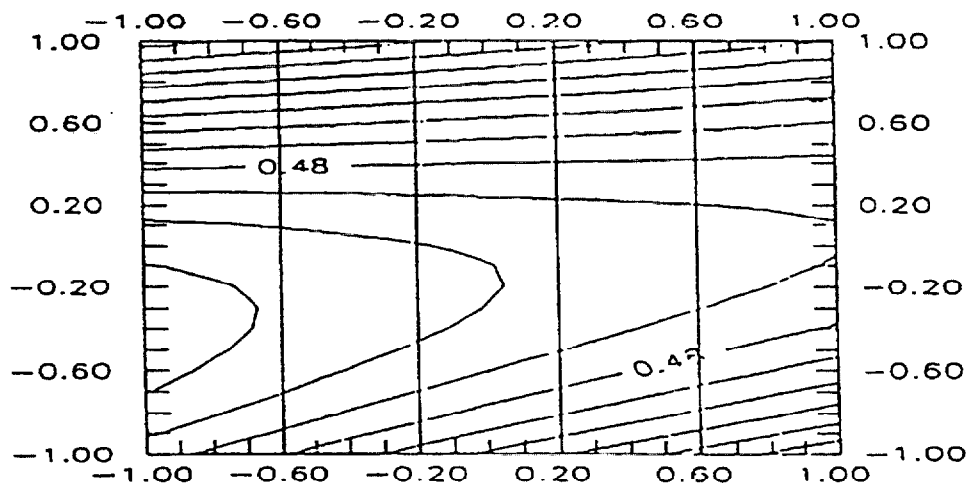
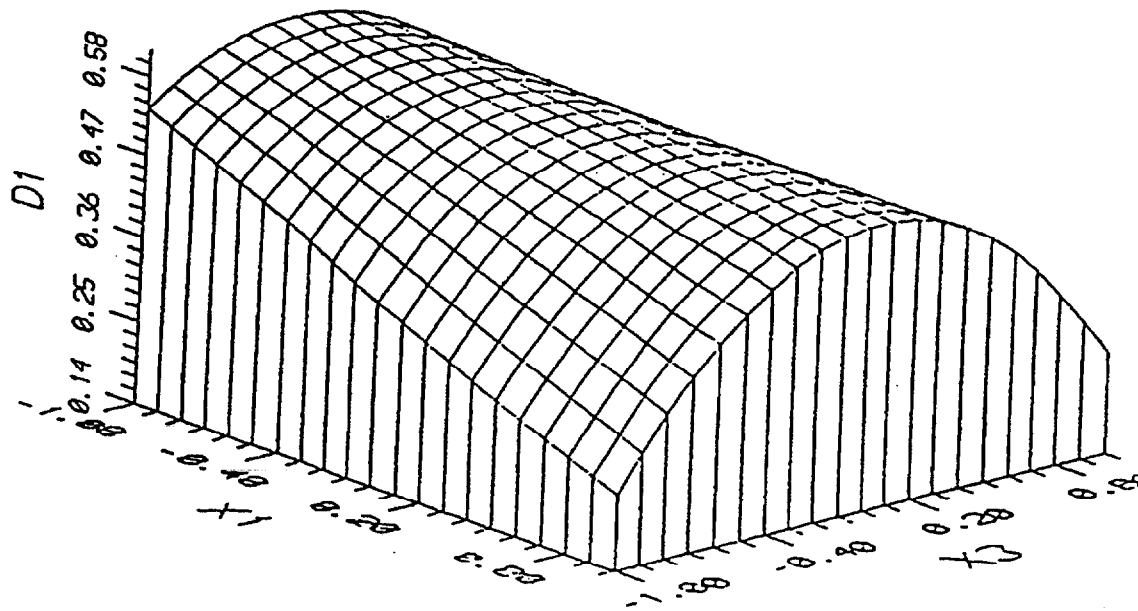
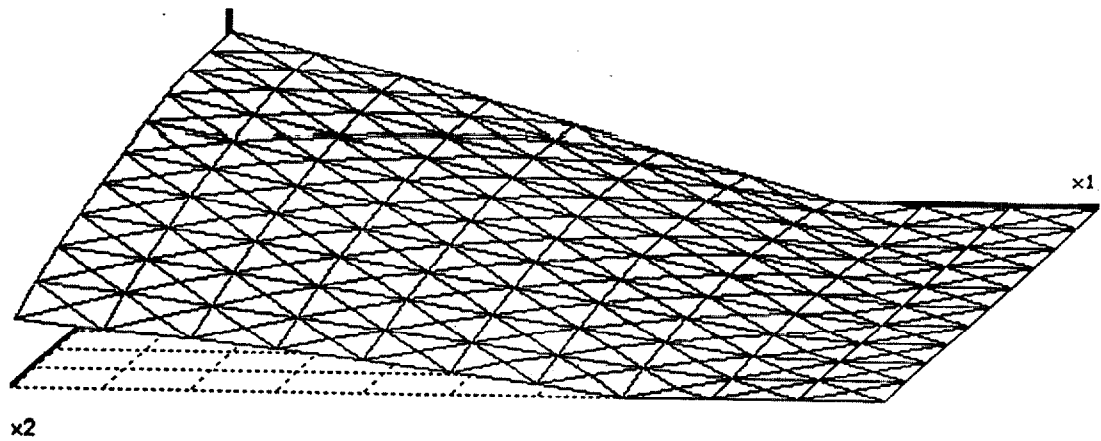

Figure 8.1: The overall desirability of the polyester concrete formulations with silica fume. Weight set I.



FUNCTION: **DESIRABILITY** MAX. VALUE: **1.8925** X = **2.500** Y = **0.026** VIEW: **NORTH**
 VARIABLES:
1 from : 2.500 to : 6.000 **2** from : 0.001 to : 0.250
 CONSTANS:
3
 value: 0.201

Figure 8.2: The overall desirability of polyester concrete with silica fume for weight set I, obtained using the materials optimization computer program MOS [7]. The out-of-plane coordinate is D1, the same as in the equivalent graph in Fig. 8.1.

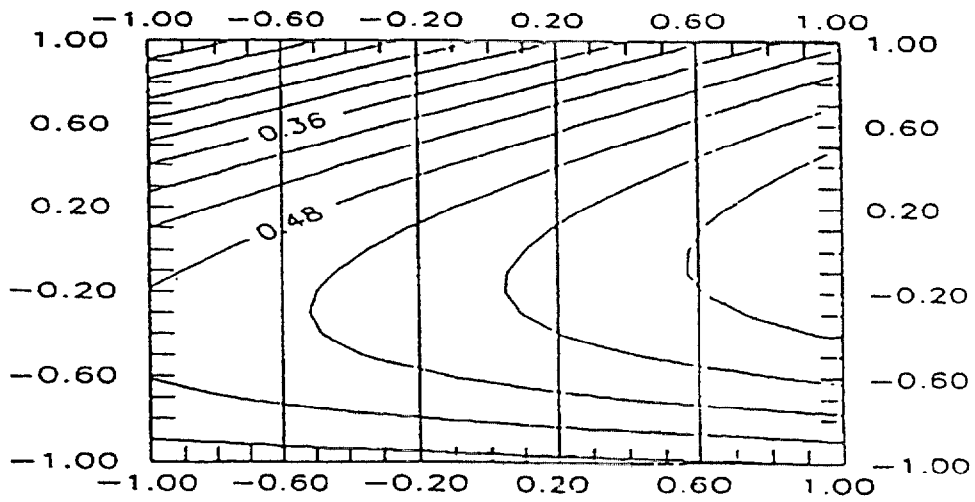
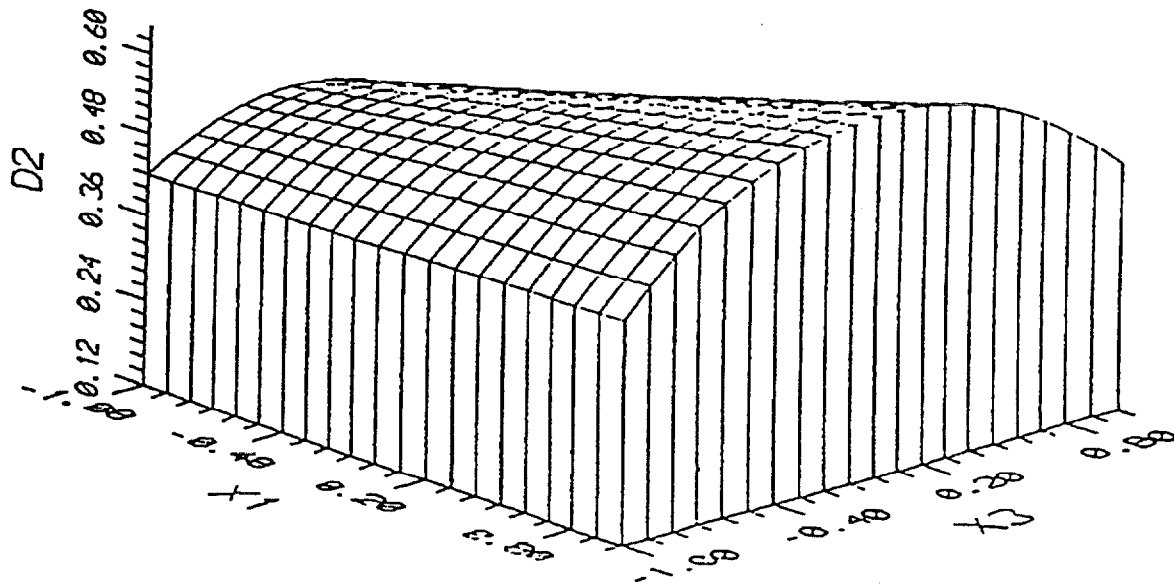

Figure 8.3: The overall desirability of polyester concrete with silica fume. Weight Set II.

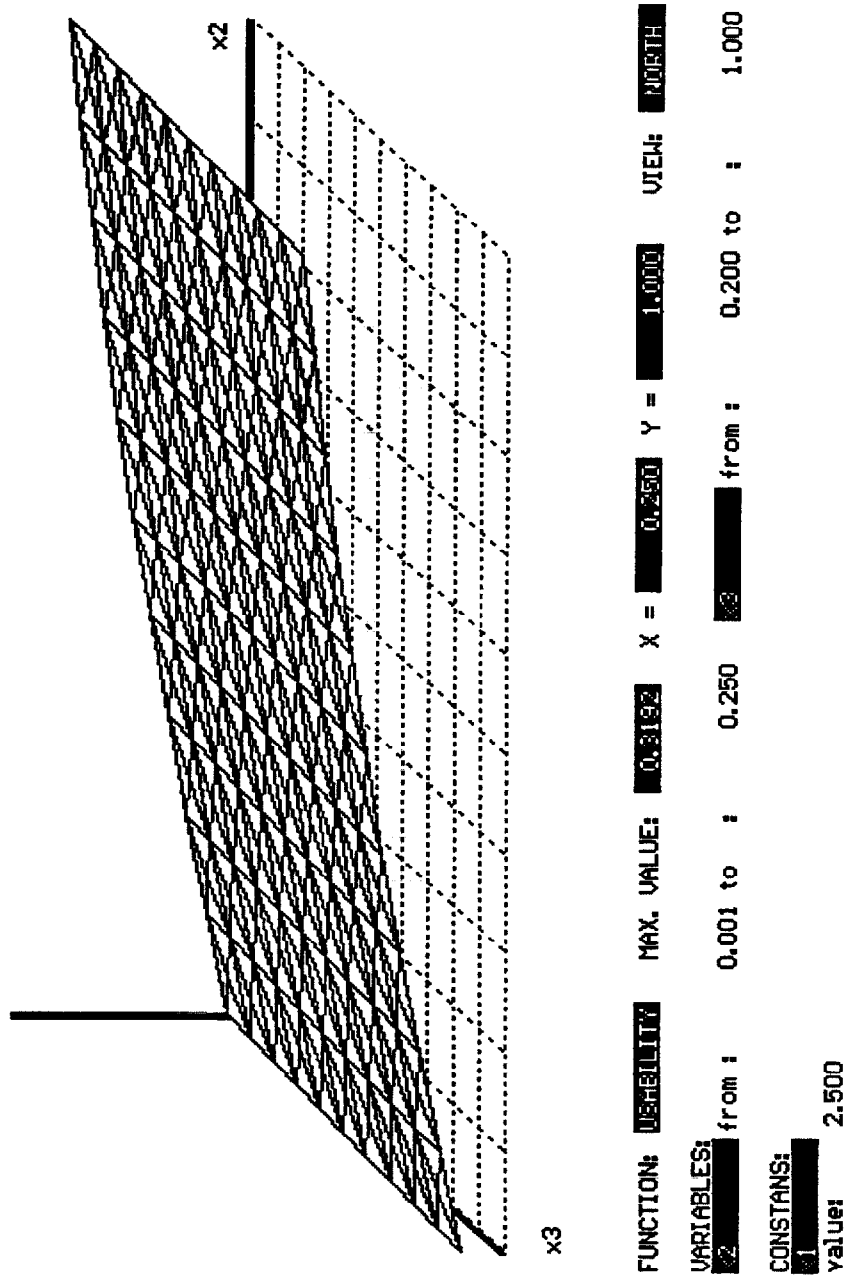

Figure 8.4: The overall desirability of polyester concrete modified by silica fume for weight set II, obtained using the material optimization computer program MOS [7]. The out-of-plane coordinate is D2, the same as in the equivalent graph in Fig. 8.3.

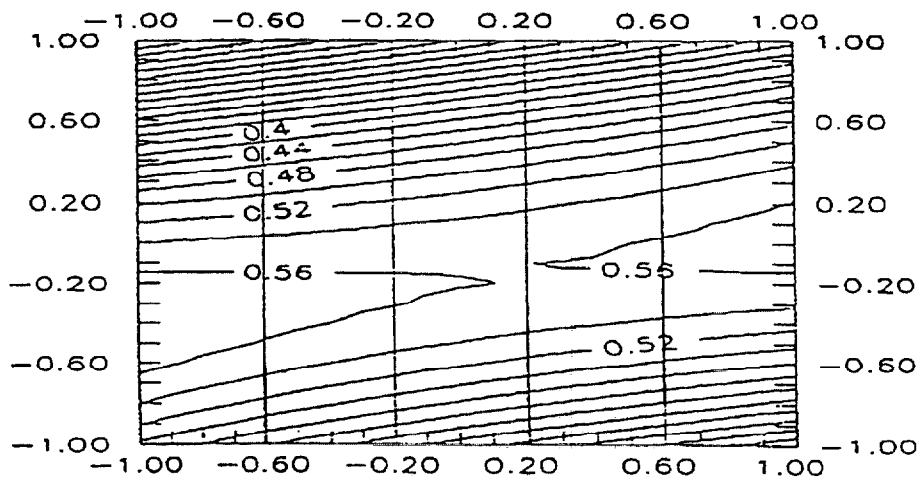
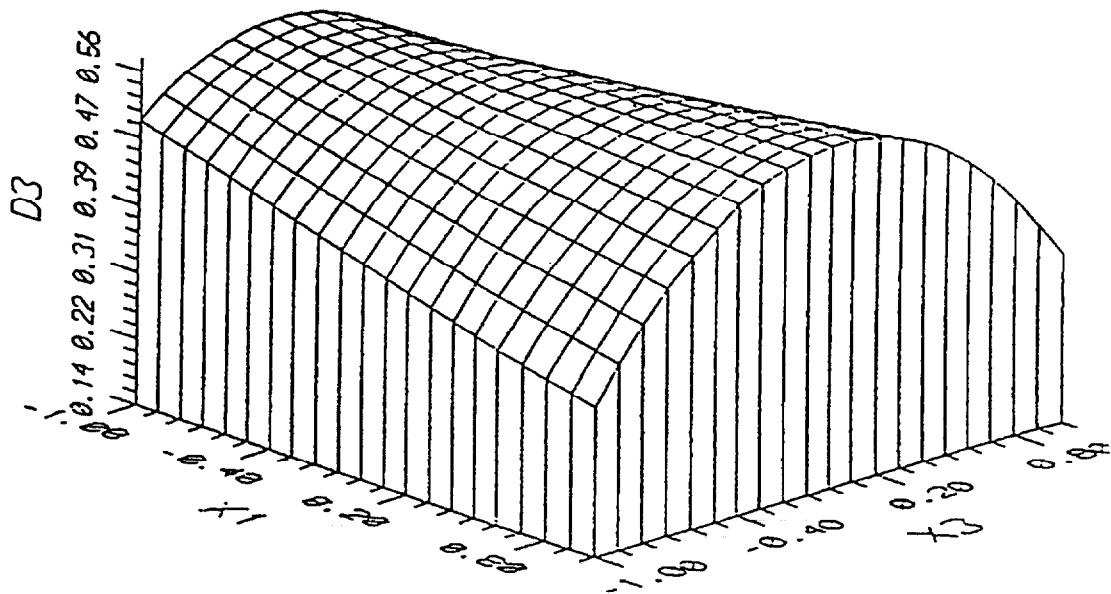

Figure 8.5: The overall desirability of polyester concrete modified by silica fume. Weight Set III.

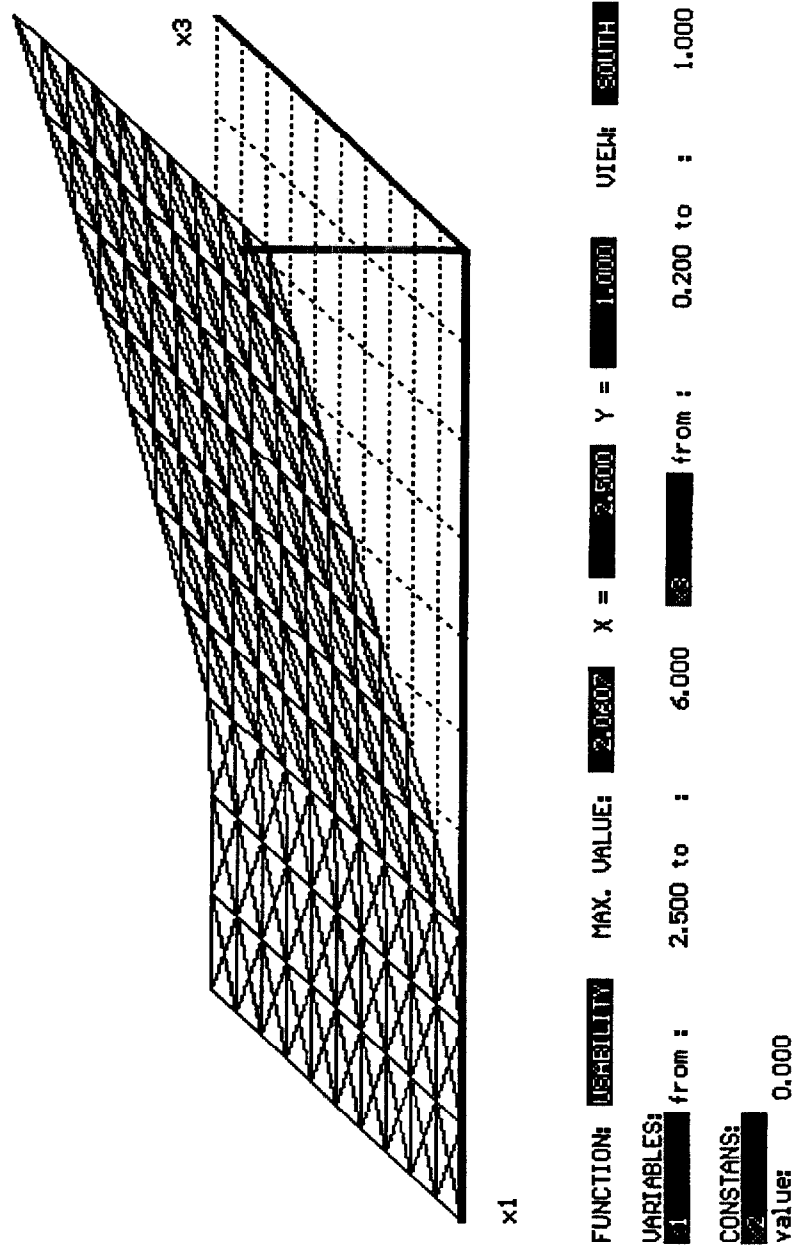

Figure 8.6: The overall desirability of polyester concrete modified by silica fume for weight set III, obtained using the material optimization computer program MOS [7]. The out-of-plane coordinate is D3, the same as in the equivalent graph in Fig. 8.5.

Table 8.2. RESULTS OF OPTIMIZATION FOR POLYESTER CONCRETE WITH SILICA FUME

	Weight Set		
	I	II	III
Optimal point (x_1, x_2, x_3) (*)	(-1,-0.85,-1)	(-1,-0.05,-1)	(-1,-0.9,-1)
Maximum value of overall desirability function	0.86	0.80	0.89
Compressive strength, MPa	69.8	69.8	69.8
Flexural strength, MPa	24.6	24.6	24.4
Modulus of elasticity, GPa	36.1	36.1	36.1

(*) If the maximum desirability appears at a parameter point, (x_1, x_2, x_3), that is on the border of the experimental domain ($-1 \leq x \leq 1$), the actual optimal point may be outside this region. However, for a value of the overall desirability that is already high (≥ 0.80), repeating the experiments with a new range was not justified because the overall desirability was unlikely to show a significant increase.

The results of the optimization and verification process indicate the following:

- Addition of silica fume made it possible to obtain higher values of the overall desirability [25].
- Addition of silica fume significantly improved the flexural strength of the polyester composite (near 25 MPa at the optimal point, an increase of about 50%) [25].
- Addition of silica fume did not significantly affect the compressive strength and modulus of elasticity of the polyester concrete [25].
- The optimal content ratio (material variable x_2) of silica fume to combined microfiller (silica fume plus quartz meal) was in the range 0.32 to 0.68 (by mass) [25].

The overall goal of using silica fume to modify polyester concrete properties was only realized for the flexural strength, and not the compressive strength and the modulus of elasticity.

8.2. Highly-filled polyester concrete

The aim of this optimization study was to determine the feasibility of laboratory manufacture of a polyester concrete with a filler-to-binder ratio of at least 20 [27]. Such a composite would be very attractive with respect to cost, due to the small amount of synthetic resin used. However, using only a small content of resin binder would likely cause lower mechanical properties. Therefore, it was necessary to determine if a satisfactory technical-economical compromise could be obtained, so that the cost could be greatly lowered and yet adequate technical properties, mainly strength, would be maintained.

The material variables were: the filler-to-binder ratio (X_1), relative content of the silane coupling agent (X_2), and relative content of microfiller (X_3). Compressive strength, flexural strength and water absorption were used to make up the overall desirability function. As in the previous study, three sets of weights of the particular properties were selected (Table 8.3) and the maximum value of the overall desirability function was calculated (Table 8.4). The results are presented graphically in Figs. 8.7-8.12. Each pair of figures, Figs. 8.7-8.8, Figs. 8.9-8.10, and Figs. 8.11-8.12, show all three possible pairs of the three materials design variables, (x_1, x_2), (x_1, x_3), or (x_2, x_3), two on the odd-numbered graph, and one on the even (MOS) graph. The isoline graphs have the same in-plane axes as the space figure next to them.

Table 8.3. OVERALL DESIRABILITY FUNCTION WEIGHTS FOR HIGHLY-FILLED POLYESTER CONCRETE

Concrete Property	Weight sets		
	I	II	III
Compressive strength	0.33	0.20	0.20
Flexural strength	0.33	0.20	0.35
Water absorption	0.34	0.60	0.45

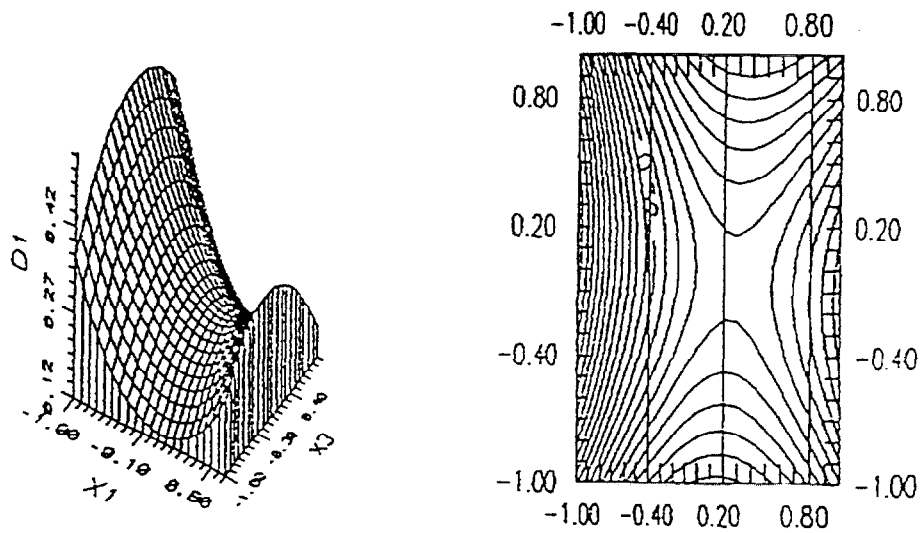
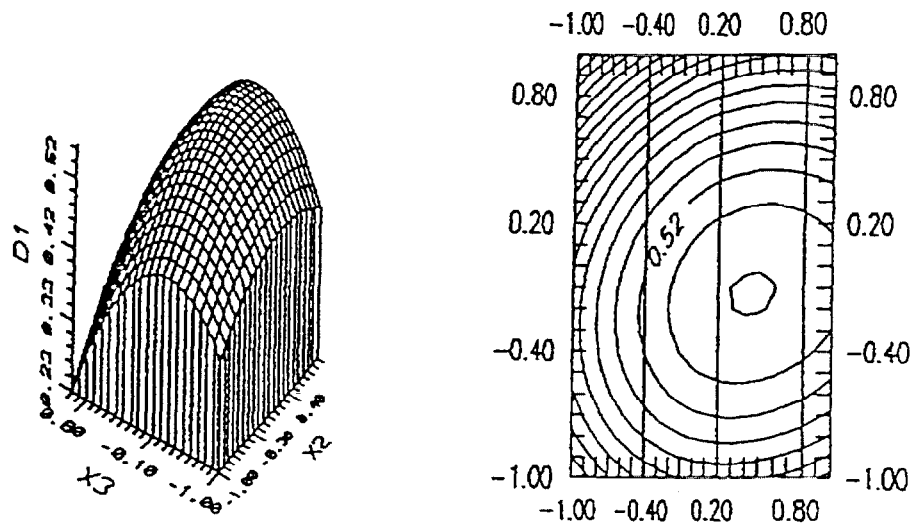

Figure 8.7: The overall desirability of the highly-filled polyester concrete. Weight Set I. The top and bottom views are for cases where different variables have been held constant.

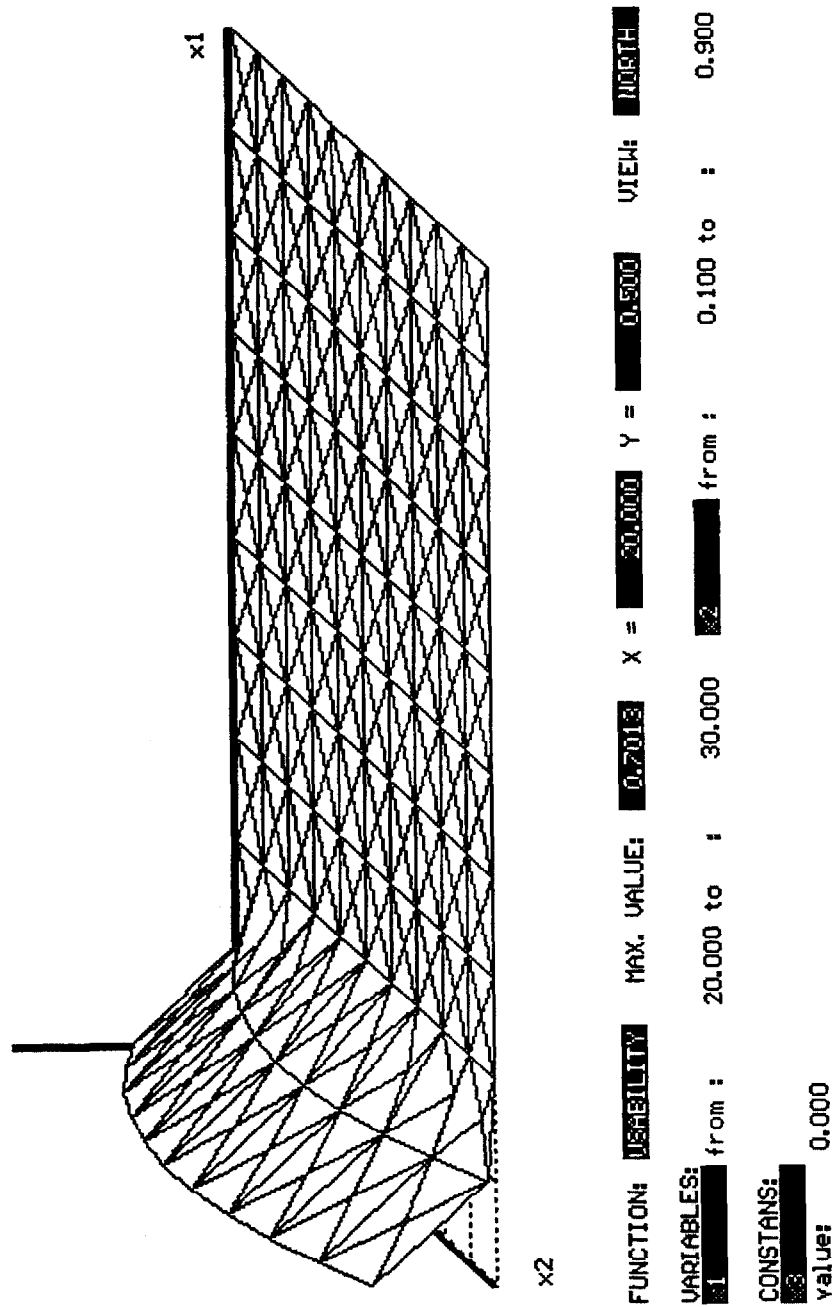

Figure 8.8: The overall desirability of the highly-filled polyester concrete for weight set I, obtained using the material optimization computer program MOS [7]. The out-of-plane axis is D1, the same as Fig. 8.7.

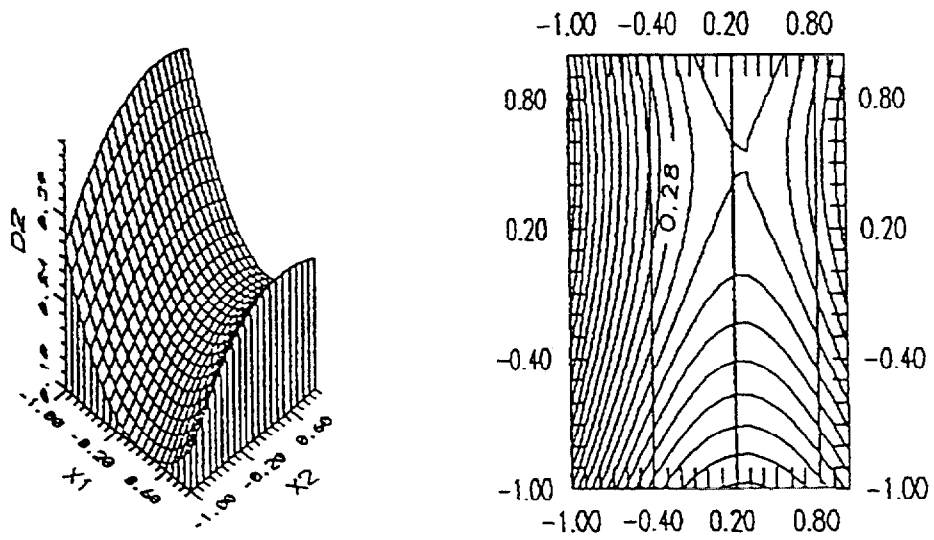
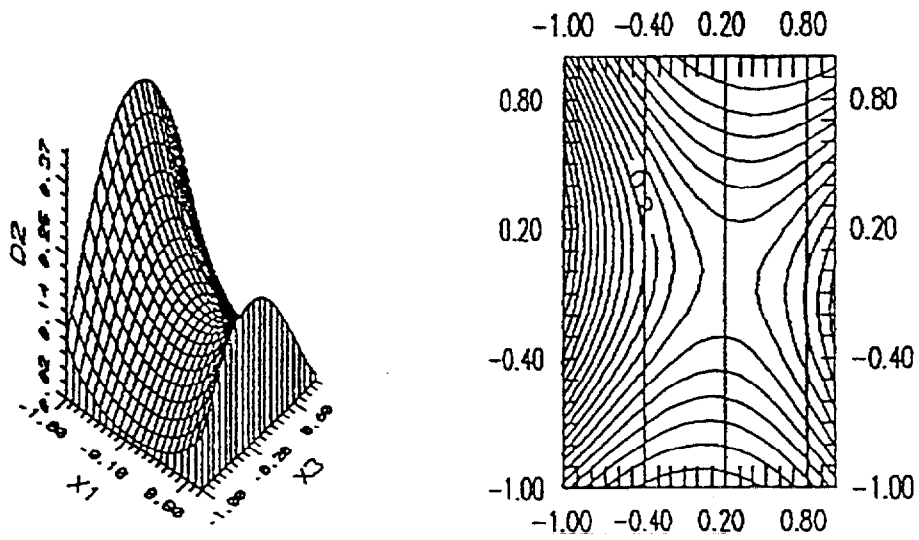

Figure 8.9: The overall desirability of the highly-filled polyester concrete. Weight Set II. The top and bottom views are for cases where different variables have been held constant.

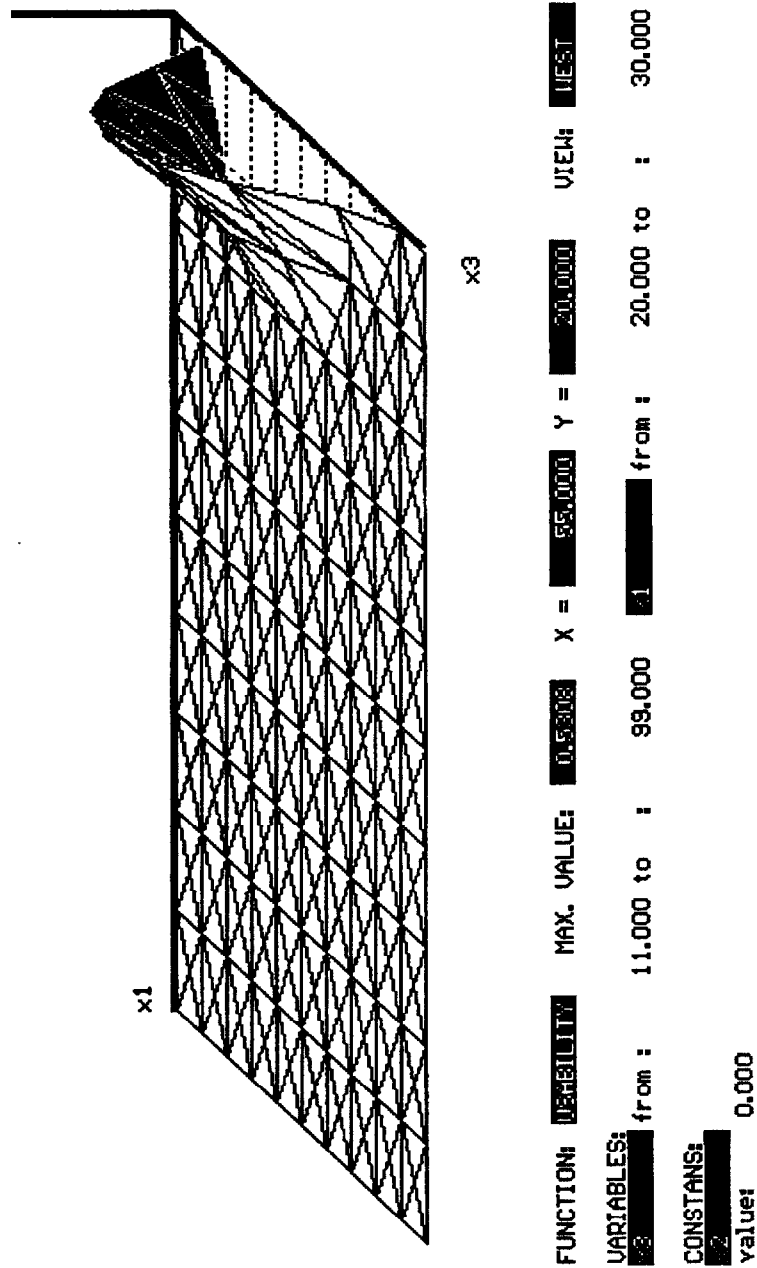

Figure 8.10: The overall desirability of highly-filled polyester concrete for weight set I, obtained using the material optimization computer program MOS [7]. The out-of-plane axis is D2, the same as in Fig. 8.9.

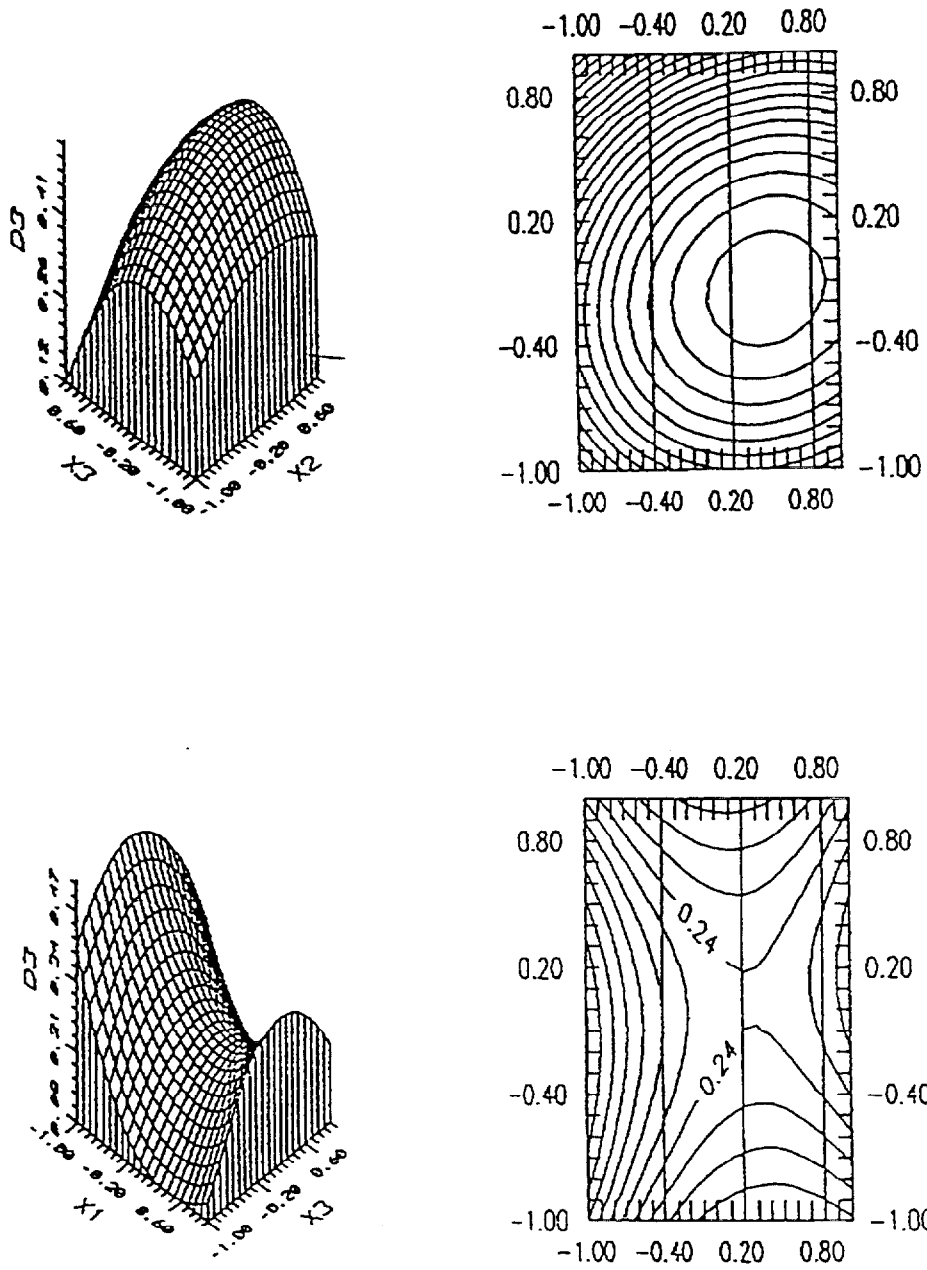

Figure 8.11: The overall desirability of highly-filled polyester concrete. Weight Set III. The top and bottom views are for cases where different variables have been held constant.

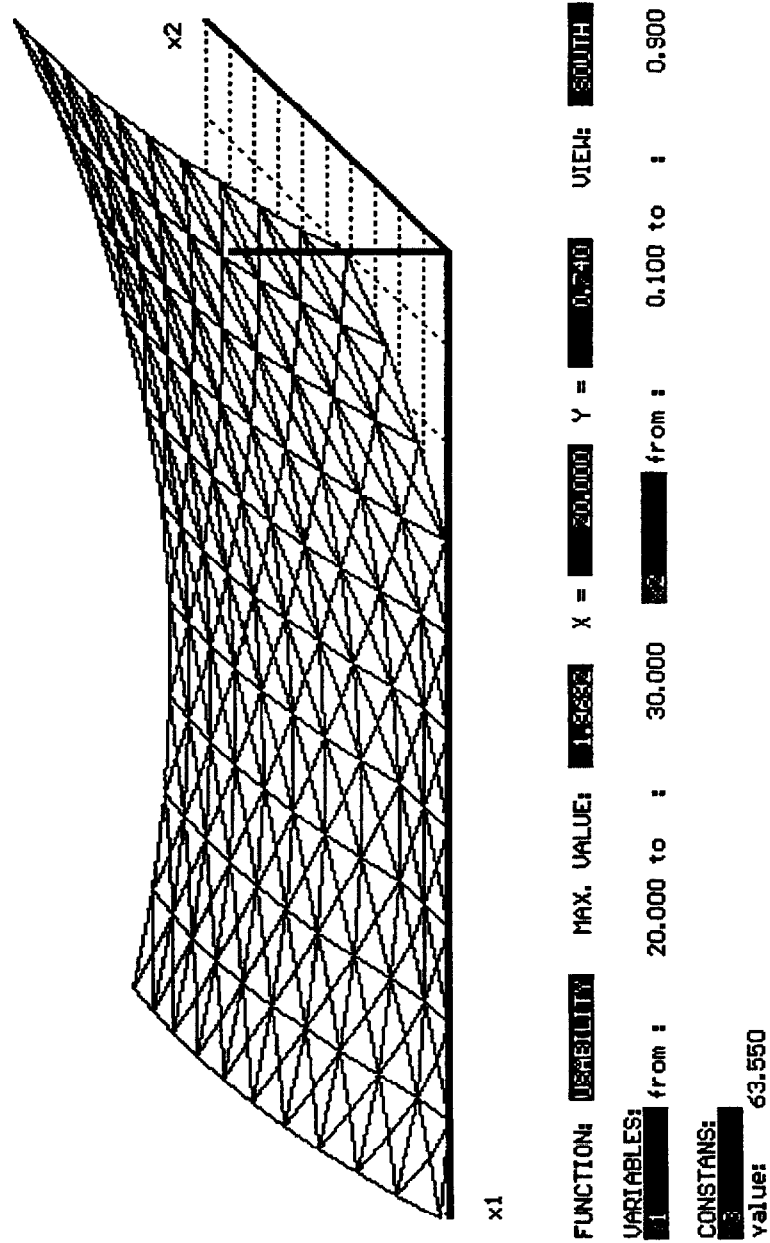

Figure 8.12: The overall desirability of the highly-filled polyester concrete for weight set III, obtained using the material optimization computer program MOS [7]. The out-of-plane axis is D3, the same as in Fig. 8.11.

Table 8.4. RESULTS OF OPTIMIZATION FOR HIGHLY-FILLED POLYESTER CONCRETE

	Weight Set		
	I	II	III
Optimal point (x_1, x_2, x_3) (*)	(-1, 0.7, 0.2)	(-1, 0.5, 0.2)	(-1, 0.6, 0.2)
Maximal value of the overall desirability	0.87	0.84	0.87
Compressive strength, MPa	16.0	16.0	16.0
Flexural strength, MPa	6.9	7.0	6.9
Water absorption, %	5.0	5.0	5.0

(*) If the maximum desirability appears at a parameter point, (x_1, x_2, x_3), that is on the border of the experimental domain ($-1 \leq x \leq 1$), the actual optimal point may be outside this region. However, for a value of the overall desirability that is already high (≥ 0.84), repeating the experiments with a new range was not justified because the overall desirability was unlikely to show a significant increase.

The highly filled polyester concrete had acceptable mechanical properties, with adequate abrasion and freeze-thaw resistance [27]. The composite also had an attractive aesthetic appearance. Because of the high filler content, there is a practically unlimited possibility of coloring the composite. In spite of the high content of the filler, the polymer mix had acceptable workability [27]. Due to the very low content of the resin, the material cost of the composite is about 80% less than the cost of "ordinary" polyester concrete. In this case, the MOS program [7] was clearly successful in optimizing polymer concrete for low cost, by using much more of the filler, which is cheaper than the polymer matrix, but without seriously degrading other important physical properties.

8.3. Epoxy concrete evaluated in terms of low flammability and combustibility

Poor fire resistance is a barrier to many applications of polymer concretes. It was of interest to determine if epoxy concrete materials with low flammability and combustibility could be produced [28], without sacrificing compressive strength. The method of improvement was to use a specially-selected multi-component and multi-functional modifier in the polymer matrix. The proportions of the components: silane A 1100 (x_1); hydrated sodium aluminosilicate, ($\text{Na}_2\text{O} \cdot \text{Al}_2\text{O}_3 \cdot \text{SiO}_2 \cdot n\text{H}_2\text{O}$) (x_2); and borax, $\text{Na}_2\text{B}_4\text{O}_7 \cdot 10\text{H}_2\text{O}$ (x_3), were the material design variables. The workability of the polymer mixture, surface quality, burning time, length of the fired part of the sample, and compressive strength were used as components of the overall desirability function [28]. Three sets of weights of the particular properties were selected (Table 8.5) and the maximum value of the overall desirability was calculated. The results are presented graphically in Figs. 8.13-8.18, and in tabular form in Table 8.6. For each weight set, the overall desirability

function (Dn, n=1,2,3) is plotted against a different pair of the five material design variables. The isoline graphs have the same coordinate axes as the space graphs next to them. Again, the even-numbered graphs are the MOS [7] versions of the odd-numbered graphs.

Table 8.5. OVERALL DESIRABILITY FUNCTION WEIGHTS FOR EPOXY CONCRETE IN FLAMMABILITY STUDY

Concrete Property	Weight Set		
	I	II	III
Workability	0.25	0.20	0.30
Flexural strength	0.25	0.20	0.30
Burning time	0.25	0.35	0.40
Length of the fired part of the sample	0.10	0.10	0
Compressive strength	0.15	0.15	0

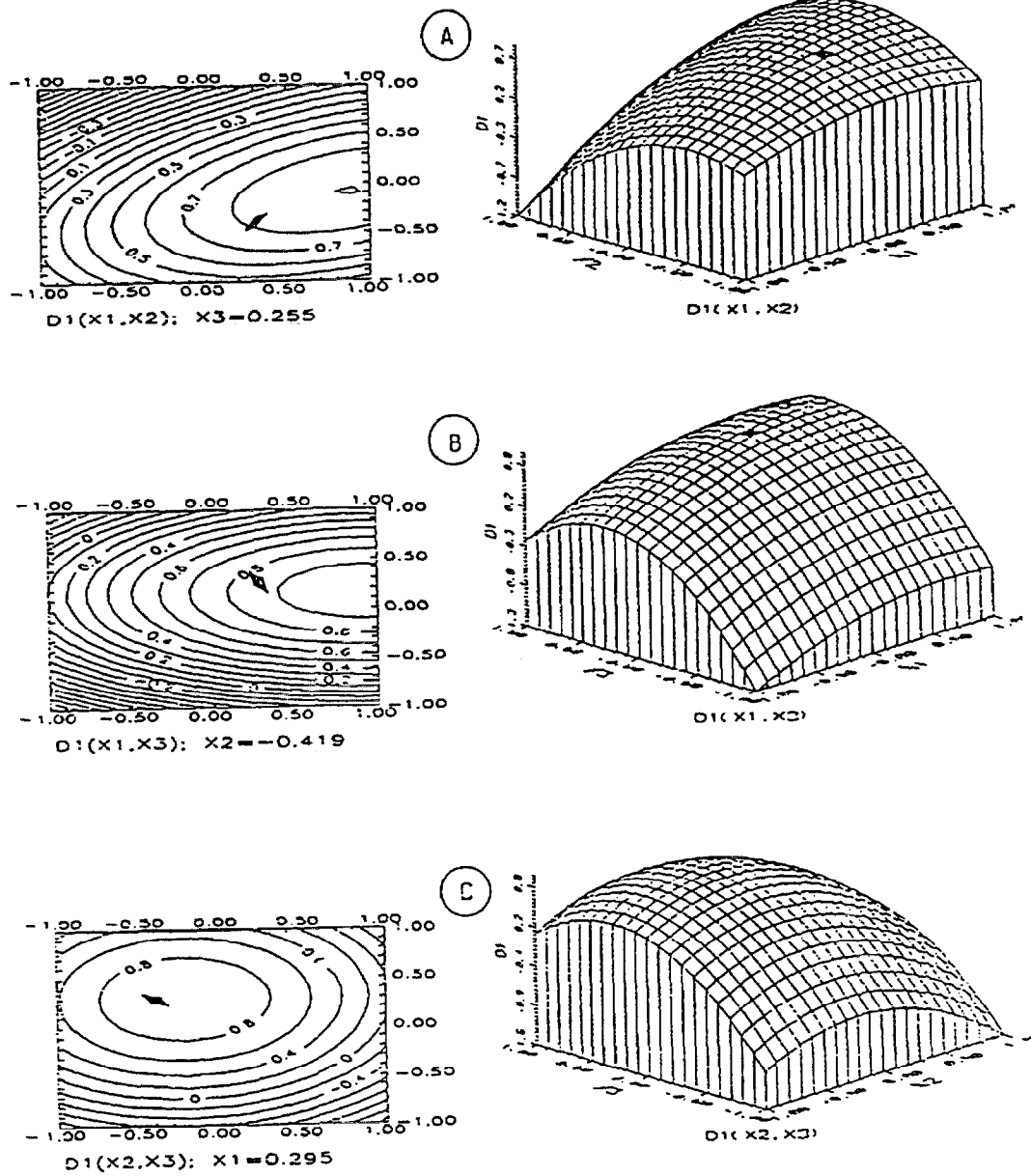

Figure 8.13: The overall desirability of the epoxy concrete in terms of low flammability and combustibility. Weight Set I. The top, middle, and bottom views are for cases where two different variables have been used for the coordinate axes.

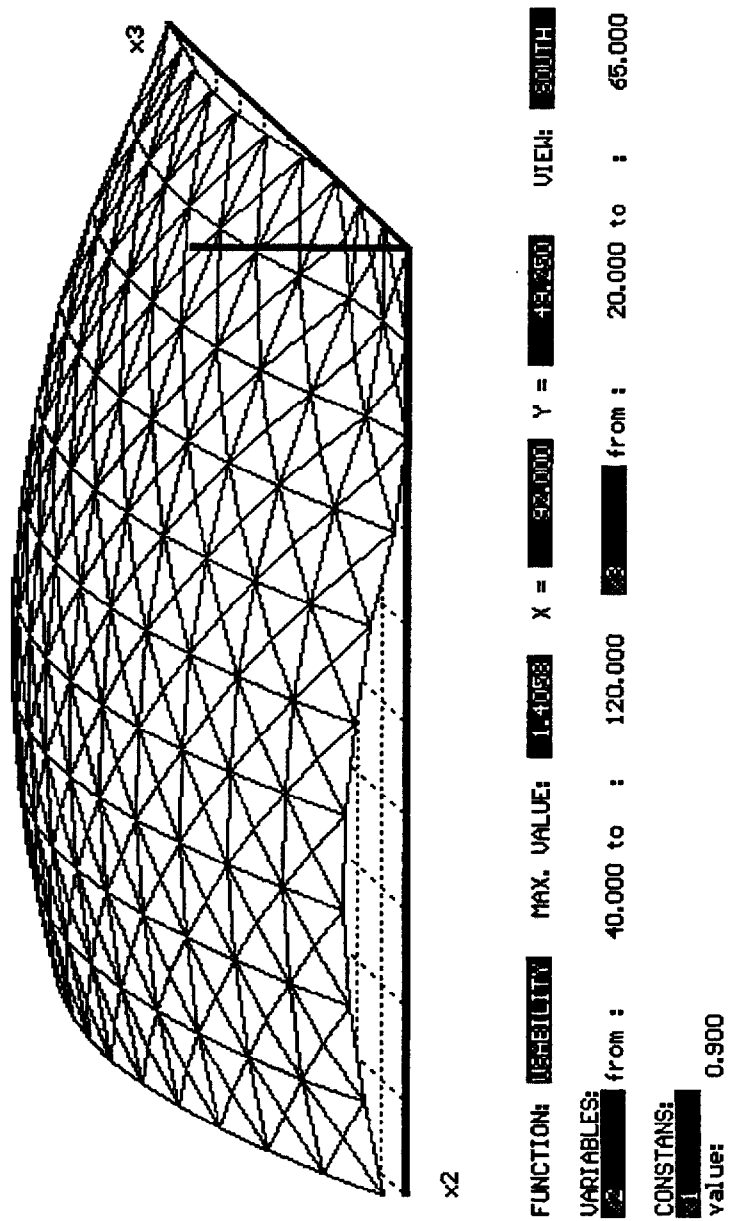

Figure 8.14: The overall desirability of the epoxy concrete in terms of low flammability and combustibility for weight set I, obtained using the materials optimization computer program MOS [7], plotted against one pair of the material design variables. The out-of-plane axis is D1, the same as in Fig. 8.13.

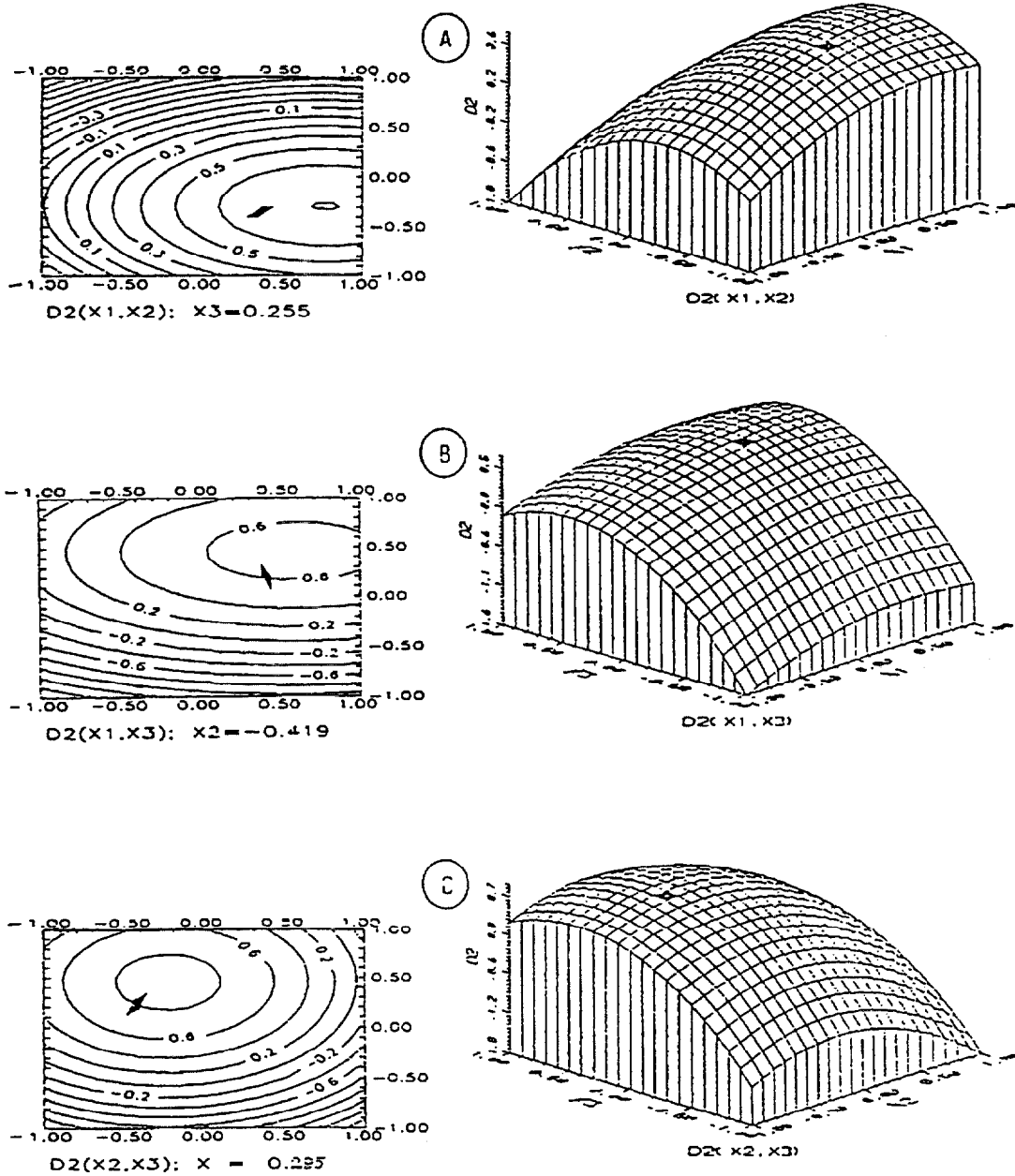
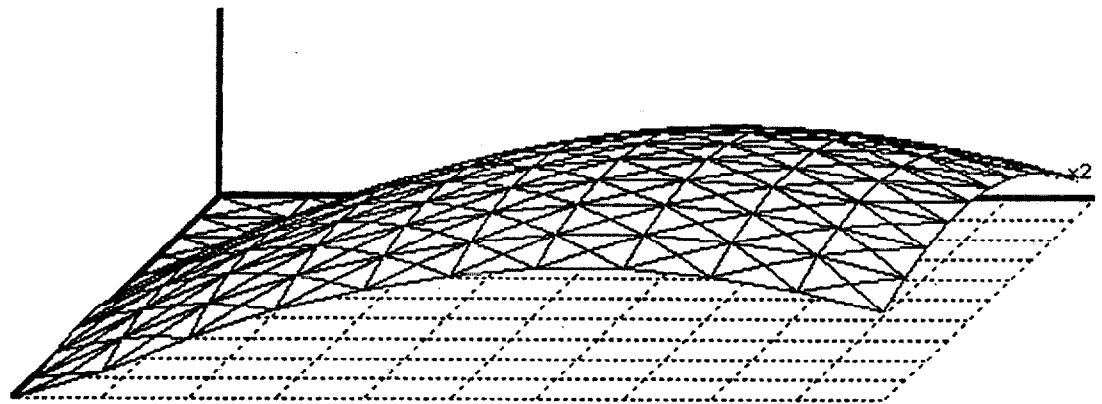

Figure 8.15: The overall desirability of the epoxy concrete in terms of low flammability and combustibility. Weight Set II. The top, middle, and bottom views are for cases where different pairs of variables have been used as the coordinate axes.



x3

FUNCTION: DESIRABILITY MAX. VALUE: 1.4008 X = 92.000 Y = 49.250 VIEW: NORTH
 VARIABLES:
 2 from : 40.000 to : 120.000 3 from : 20.000 to : 65.000
 CONSTANS:
 1
 value: 0.800

Figure 8.16: The overall desirability of the epoxy concrete in terms of low flammability and combustibility for weight set II, obtained using the material optimization computer program MOS [7], plotted against two of the material design variables. The out-of-plane axis is D2, the same as in Fig. 8.15.

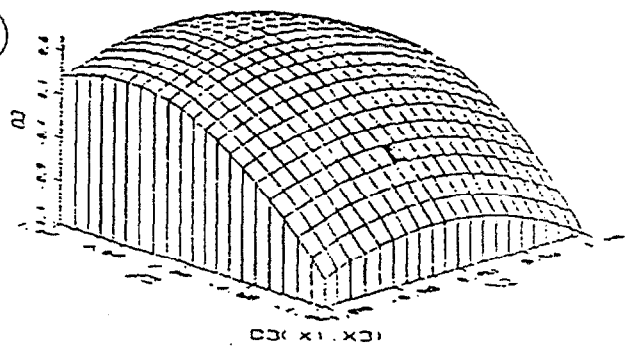
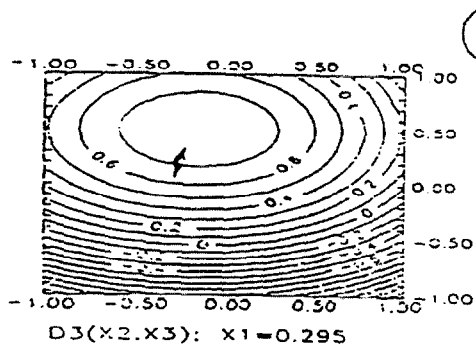
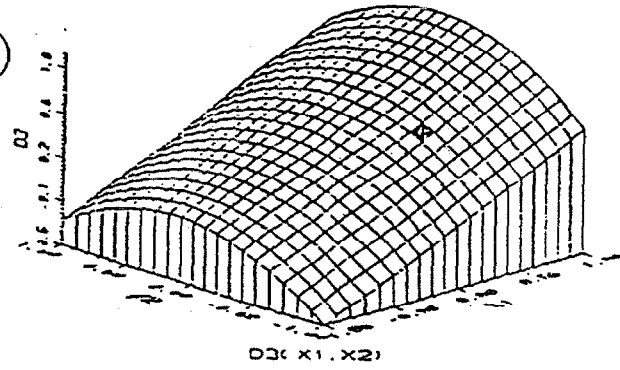
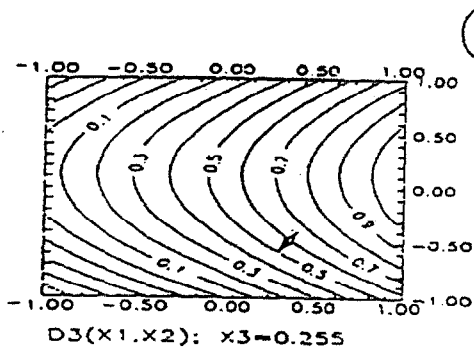
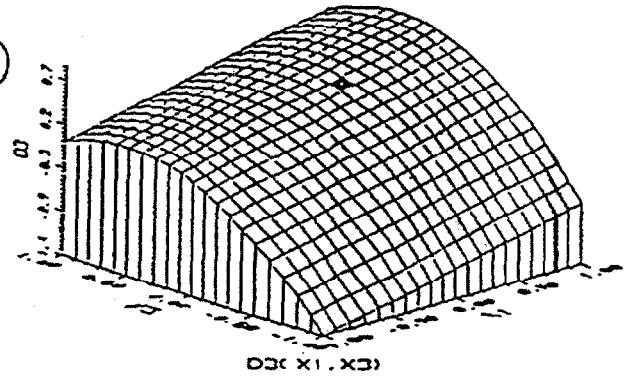
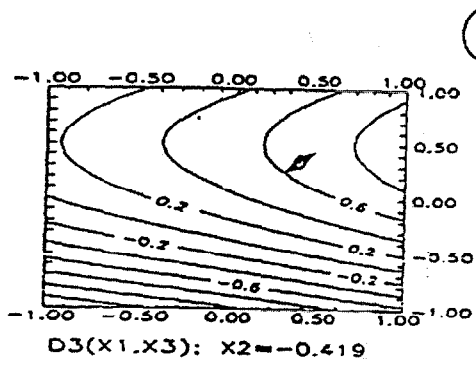
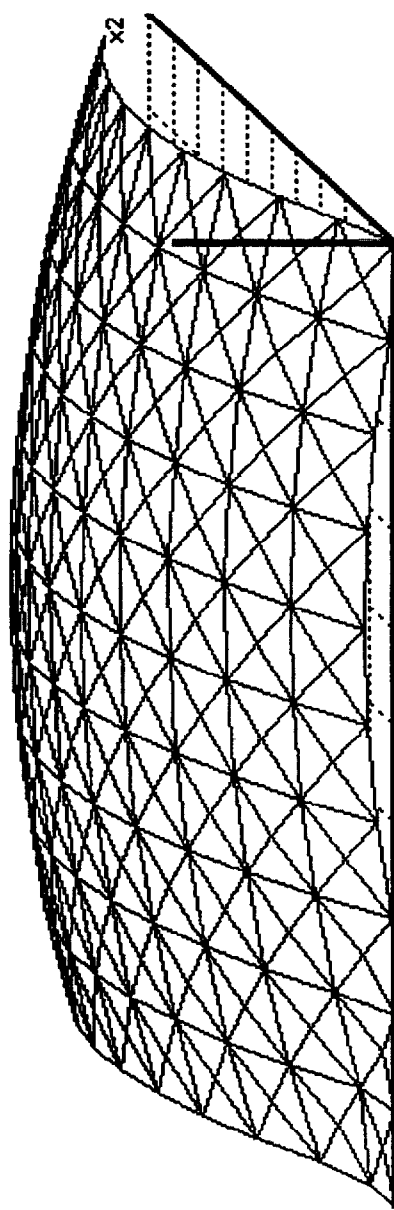

Figure 8.17: The overall desirability of the epoxy concrete in terms of low flammability and combustibility. Weight Set III. The top, middle, and bottom views are for cases where two different variables have been used for the coordinate axes.



x1
 x2
 FUNCTION: DESIRABILITY MAX. VALUE: 1.9881 X = 0.700 Y = 88.000 VIEW: SOUTH
 VARIABLES: from : 0.200 to : 1.200 from : 40,000 to : 120,000
 CONSTANS: value: 53.500

Figure 8.18: The overall desirability of the epoxy concrete in terms of low flammability and combustibility for weight set III, obtained using the material optimization computer program MOS [7], plotted against two of the material design variables. The out-of-plane axis is D3, the same as in Fig. 8.17.

**Table 8.6 RESULTS OF OPTIMIZATION OF EPOXY CONCRETE
FOR FLAMMABILITY AND COMBUSTIBILITY**

	Weight Set		
	I	II	III
Optimal point (x_1, x_2, x_3)	(0.4, 0.3, 0.3)	(0.2, 0.3, 0.3)	(0, 0.2, 0.5)
Maximum value of the overall desirability	0.78	0.78	0.81
Workability, cm	6.5	6.5	6.5
Burning time, s	1.4	1.4	1.0
Length of fired part of sample, mm	3.3	2.5	1.9
Compressive strength, MPa	103.7	103.7	102.3
Flexural strength, MPa	37.2	35.9	34.2

The results show that an epoxy concrete of low combustibility and flammability was obtained. The material had good mechanical properties, with compressive strength above 100 MPa, and flexural strength above 34 MPa. This polymer concrete, because of its low flammability, was classified according to Polish standards as “non-flammable” [28]. Ordinary polymer concrete is usually classified as “flammable” [28]. This epoxy concrete can now be used in applications that were not permissible before, because of fire safety regulations. Again, the optimization computation resulted in a useful material whose properties were accurately predicted by the computer program MOS.

9. SUMMARY

This is the final report on the project “Polymer Concrete Composites” carried out under the framework of the Joint US-Polish Fund Maria Sklodowska-Curie II. The main objective of the project was to develop a statistical method for the material design and optimization of polymer concrete. Material models for various polymer concrete materials were developed as the basis of the optimization process, and were formulated in terms of quadratic functions that were fit in a regression process to experimental data measured according to a statistical design. An overall desirability function was applied in optimizing the performance of the polymer concrete materials. Optimization results for various polymer concrete formulations were determined, analyzed both analytically and graphically, and compared to the results of experiments. The three cases considered were: the use of silica fume in polyester concrete, the production of an inexpensive highly-filled polyester concrete that did not sacrifice important technical properties, and the production of an epoxy concrete with low flammability but good mechanical properties. The reliability of

the proposed method was demonstrated for both polyester and epoxy concrete. The usefulness of the method for product development and identification of the effects of major variables on performance was demonstrated. A computer program was developed for the optimization of polymer concrete, and was verified in the experimental studies. This user-friendly program should be a generally useful tool for polymer concrete designers [7].

Acknowledgements

There was fruitful and mutually beneficial cooperation between the U.S. and Polish partners. It is their sincere wish to continue this cooperation in the future.

10. REFERENCES

1. Clifton, J., Knab, L.: Service life of concrete. National Institute of Standards and Technology Interagency Report 89-4086, Gaithersburg, MD 1989.
2. Czarnecki, L.: Vielseitiger Polymerbeton. *Kunststoffe im Bau*, 4 (184), str. 5-10.
3. Czarnecki, L.: Polymer concrete. Arkady, Warszawa, 1982 [in Polish].
4. Piasta, Z., Czarnecki, L.: Analysis of material efficiency of resin concretes. II International Symposium on Brittle Matrix Composites, Cedzyna 1988, pp. 593-602.
5. Czarnecki, L.: Introduction to material model of polymer concrete. IV International Congress on Polymers in Concrete, Darmstadt 1984, pp. 50-64.
6. Czarnecki, L., Weiss, V.: Meaning of synergistic effects in composite materials and structures. II International Symposium on Brittle Matrix Composites, Cedzyna 1988, pp. 526-535.
7. Czarnecki, L., Garbacz, A., Piela, P., Lukowski, P.: Material Optimization System: User's Guide, Warsaw University of Technology Internal Report (1994).
8. Van Gemert D., Czarnecki, L., Bareš R.: Basis for selection of PC and PCC for concrete repair. *International Journal of Cement Composites and Lightweight Concrete*, 10 (1988), pp. 121-123.
9. Czarnecki, L.: The status of polymer concrete. *Concrete International Design and Construction*, 7 (1985), pp. 47-53.
10. Czarnecki, L.: Polymer concrete use in transportation, hydrotechnics and industry. *TIZ-Fachberichte*, 6 (1987), pp. 410-416.
11. Czarnecki, L., Lukowski, P., Nejman, R.: Statistical evaluation of homogeneity of epoxy concrete. XXXVI Scientific Conference of Polish Academy of Sciences, Krynica 1990, Vol. 4, pp. 17-21 [in Polish].
12. Paturojew, W.W.: Technology of polymer concrete. Strojizdat, Moscow, 1986 [in Russian].
13. Cornell, J.A.; Experiments with mixtures; designs, models and the analysis of mixture data. John Wiley & Sons, New York-Chichester, 1981.
14. Kacprzyński, B.: Design of experiments; mathematical basis. Wydawnictwa Naukowo-Techniczne, Warszawa, 1974 [in Polish].
15. Piasta, A.: Method for selecting the optimal design of experiments in technological research. D.Sc. thesis, Kielce University of Technology, Kielce, 1978.
16. Box, G., Draper, N.: Empirical model-building and response surfaces. John Wiley & Sons, New York - Toronto 1987.
17. Box, G.E.P., Draper, N.R.: The choice of second order rotatable designs. *Biometry* 50 (163), pp. 335-352.

18. Czarnecki, L., Clifton, J., Lukowski, P.: Material model for polymer concrete as the basis for its optimization. *Beton I Żelezobeton*, 2 (1993), pp. 18-20 [in Russian].
19. Kapuściński, J., Pucilowski, K., Wojciechowski, S.: Design and technology of composite materials. Wydawnictwa Politechniki Warszawskiej, Warszawa, 1983.
20. Czarnecki, L., Clifton, J.: Polymer concretes; material design and optimization problems. *International Symposium on Concrete Polymer Composites*, Bochum 1991, pp. 63-71.
21. Derringer, G., Suich, R.: Simultaneous Optimization of Several Response Variables. *Journal of Quality Technology*, 4 (1980), pp. 214-219.
22. Harrington, E.C.: The desirability function. *Industrial Quality Control*, 10 (1965), pp. 494-498.
23. Czarnecki, L.: Polymer concrete material design: material model – optimization – usability concept. *International Colloquium "Cement-Polymer Compositen in de Bouw"*, Katholieke Universiteit Leuven 1990, pp. 1-14.
24. Czarnecki, L., Lenarcik, A., Lukowski, P., Piasta, Z.: A multicriteria optimization of epoxy concrete using the desirability function approach. *IV International Symposium on Brittle Matrix Composites BMC-4*, Warsaw 1994 (ed. A.M. Brandt, V.C. Li, and I.H. Marshall), pp. 245-254.
25. Kolakowski, K.: Polyester composites modified by silica fume. M.Sc. thesis, Warsaw University of Technology, Warszawa, 1991 [in Polish].
26. Silica fume in concrete. *ACI Material Journal*, 3-4 (1987).
27. Wilk, T.: Highly-filled polyester concrete. M.Sc. thesis, Warsaw University of Technology, Warszawa, 1991 [in Polish].
28. Wiackowska, A.: Polymer mortars and concretes of low combustibility and flammability. Ph.D. thesis, Warsaw University of Technology, Warszawa, 1991 [in Polish].

11. NOMENCLATURE

A_c - adhesion to concrete
 A_s - adhesion to steel
 α_T - linear thermal expansion coefficient
B - binder
BP - benzoil peroxide
D - overall desirability
d - density
DMA - dimethylaniline
 E_c - modulus of elasticity in compression
 E_t - modulus of elasticity in tension
 ε_1 - linear hardening shrinkage
F - filler
g - grindability
 h_B - Brinnel hardness
M - microfiller
P - Poisson's ratio
S - sand
 R_c - compressive strength
 R_g - tensile strength in bending
 R_r - tensile strength
 S_f - silica fume
Sil - silane
 W_A - water absorption
 x_i - standardized material variable
Z4A - aluminosilicate Z4A

APPENDIX A. PROJECT CONSULTANTS

Dr. David W. Fowler, Professor
(area of collaboration:
polymer concrete application)

The University of Texas
Civil Engineering Department
Austin, Texas 78712
Tel: (512) 471-4499

Dr. J. Francis Young, Professor
(area of collaboration:
portland cement concrete as
a base material)

The University of Illinois
Dept. of Civil Eng.
Urbana, Illinois 61801
Tel: (217) 244-6210

Dr. Donald C. Bogue, Professor
(area of collaboration:
polymers as binders)

The University of Tennessee
Dept. of Mater. Sci. and Engin.
Knoxville, Tennessee 33996-2200
Tel: (615) 974-5339

Drs. Jack Fontana and Larry Kukacka
(area of collaboration;
concrete-like composite materials)

Brookhaven National Laboratory
Materials Development and Applied
Science Department
Upton, NY 11973
Tel: (516) 282-3040

APPENDIX B. LIST OF PUBLISHED PAPERS ASSOCIATED WITH THE PROJECT

1. Czarniecki, L., Kukowski, P., Nejman, R.: Statistical evaluation of homogeneity of epoxy concretes. XXXVI Scientific Conference of Polish Academy of Sciences, Krynica 1990, Vol. 4, pp. 17-21 [in Polish].
2. Czarniecki, L.: Polymer concrete material design: material model - optimization - usability concrete. International Colloquium "Cement-Polymer Composites in de Bouw", Katholieke Universiteit Leuven 1990, pp. 1-14.
3. Czarniecki, L.: Polymer concrete: Material optimization problem. Scientific Session on Building Materials - Up-to-date Trends in Research and Development, Kraków 1990, pp. 243-253 [in Polish].
4. Czarniecki, L., Clifton, J.: Polymer concretes; material design and optimization problems. International Symposium on Concrete Polymer Composites, Bochum 1991, pp. 63-71.
5. Czarniecki, L., Clifton, J.R., Hadeev, N.W.: Polymer composite - portland cement concrete: Joint material optimization problem. International Seminar on Calculations and Computer Design of Wood Structures, Vladimir-Suzdal, 1991, pp. 45-46 [in Russian].
6. Czarniecki, L., Wiackowska, A.: Non-flammable unsaturated polyester mortars. VII International Congress on Polymers in Concrete, Moscow 1992, pp. 378-388.
7. Czarniecki, K., Clifton, J., Glodkowska, W.: Problem of compatibility of polymer mortars and cement concrete system. International Colloquium "Material Science and Restoration", Esslingen 1992.
8. Clifton, J.R., Czarniecki, L., Lukowski, P.: Material model as a basis for optimization of polymer concrete. International Seminar of Theoretical Basis of Building, Warsaw-Moscow, 1992, pp. 44-50.
9. Czarniecki, L., Clifton, J.R., Lukowski, P.: Material model of polymer concrete as the basis for its optimization. Beton i Żelezobeton, 2 (1993), pp. 18-20 [in Russian].