

NISTIR 6323

**Screening Methods for Agent Compatibility
with People, Materials, and the Environment**

Marc R. Nyden

Stephanie R. Skaggs

Building and Fire Research Laboratory
Gaithersburg, Maryland 20899

Universal Technical Services, Inc.
Albuquerque, NM 87111

NIST

United States Department of Commerce
Technology Administration
National Institute of Standards and Technology



NISTIR 6323

**Screening Methods for Agent Compatibility
with People, Materials, and the Environment**

Marc R. Nyden

Stephanie R. Skaggs

April 1999
Building and Fire Research Laboratory
National Institute of Standards and Technology
Gaithersburg, MD 20899

Universal Technical Services, Inc.
Albuquerque, NM 87111



U.S. Department of Commerce
William M. Daley, *Secretary*
Technology Administration
Gary R. Bachula, *Acting Under Secretary for Technology*
National Institute of Standards and Technology
Raymond G. Kammer, *Director*

INTRODUCTION	1
BACKGROUND	3
Status of the Field Prior to the Workshop	3
Environmental Impact	3
Materials Compatibility	4
Toxicity	5
Summary of Workshop Presentations and Discussions	6
Environmental Impact	7
Materials Compatibility	11
Toxicity	20
CONSENSUS SCREENING METHODS	24
Procedures	24
Environmental Impact	24
Materials Compatibility	28
Toxicity	31
Implementation of Screens	42
SUMMARY AND CONCLUSIONS	49

Acknowledgements

The authors would like to acknowledge the following people who contributed to this report by making presentations at the NGP Workshop on Screening Methods for Agent Capability with People, Materials and the Environment which was held at NIST on Nov 14 and 15, 1997: Dr John Daniel of the National Oceanic and Atmospheric Administration, Dr. Robert Huie of the National Institute of Standards and Technology (NIST), Dr. Robert Tapscott of the New Mexico Research and Engineering Institute, Mr. Richard Harris (NIST), Professor William Waldron of Baker Junior College, Dr. Richard Ricker (NIST), and Dr. David Mattie of the Air Force Research Laboratory. We would also like to thank the workshop participants who are listed in Table 1.

Abstract

A workshop on fire suppressant agent compatibility with people, materials and the environment was held at the National Institute of Standards and Technology on November 14 and 15, 1997, which was attended by approximately 40 representatives from government, academia, and industry. The participants were asked to assess currently used screening methods for each of the following properties of candidate fire suppressants: environmental impact (including ozone depletion potential, global warming potential, and atmospheric lifetime); materials compatibility (including long-term storage stability, the interaction of the agent with metals, gaskets and lubricants, and the compatibility of the agent and its combustion by-products with potentially exposed weapons systems); and toxicity (including acute, genetic, subchronic, developmental, and cardiac sensitization). For each property, the workshop participants compared currently used measurement methods and identified the best method for future use in screening candidates for the next generation of fire suppressants. Each of these "best current" methods was evaluated and given one of the following designations: acceptable as is, acceptable with modifications, or unacceptable. At the conclusion of the workshop, a consensus screening method was advanced for each property.

Introduction

Halon fire extinguishants, including CF_3Br and CF_2ClBr (halons 1301 and 1211, respectively), were included in the list of halogenated chemicals identified in The Montreal Protocol of 1987 as being deleterious to stratospheric ozone. An amendment to the Protocol caused commercial production of halons to cease at the beginning of 1994. A national effort is underway to find replacements.

The Next Generation Fire Suppression Technology Program (NGP) was organized as part of this national effort to identify new, cost-effective technologies for fire suppression in the highly space and weight-constrained environments of current weapons systems. The objective of one of the key elements (3A) of this program is to develop screening methods for the assessment of fire suppression effectiveness of agents deployed in the diverse fire fighting scenarios that these weapons systems present. A parallel effort was needed to identify screens for the other key indicators of agent acceptability as well. This project (3B/2/8) was proposed in response to this need. The objective is to document the best available methods for screening new fire suppressants and their fire degradation products for toxicity, environmental impact, and materials compatibility.

The first item of business was to review the existing protocols. In this pursuit, a workshop on agent compatibility with people, materials and the environment was held at the National Institute of Standards and Technology (NIST) on November 14 and 15, 1997. Approximately 40 representatives from government, academia, and industry participated in the evaluation and revision of current test methods for application in screening candidates for the next generation of fire suppressants. The names and affiliations of the participants are listed in Table 1.

At the onset of the workshop, a distinction was made between screening and evaluation/analysis tests. Screening tests are meant to provide guidance in the elimination of unsuitable compounds from a long list of candidates, whereas evaluation/analysis tests are performed as part of the risk assessment process that is required for all halon replacement chemicals. The focus of the workshop was on the former.

With this in mind, the workshop participants were asked to assess currently used screening methods for each of the following properties of candidate fire suppressants:

- environmental impact (including ozone depletion potential, global warming potential, and atmospheric lifetime);
- materials compatibility (including long-term storage stability, the interaction of the agent with metals, gaskets and lubricants, and the compatibility of the agent and its combustion by-products with potentially exposed weapons systems); and

- toxicity (including acute, genetic, subchronic, developmental, and cardiac sensitization).

Table 1. List of Workshop Participants

Participant	Affiliation
Doug Dierdorf	Applied Research Associates
Gary Jepson	Mantech Environmental Technology
Bob Tapscott	New Mexico Engineering and Research Institute
Roger Bullard	Northrop Grumman
Rich Hansen	United States Coast Guard
Larry Grzyll	Mainstream Engineering
Mike Edwards	UKMOD
Paul Rivers	3M
Doug Mather	New Mexico Engineering and Research Institute
Steve Hoke	AEHL
Gary Holland	Primex
Scott Hammann	Boeing
Thomas Berkel	Boeing
Bill Biscontini	
Adam D. Farnham	Chesapeake Engineering and Design
John F. McFassel	STAEC-SL-F
Bob Carpenter	NMRI/TD
Stephanie Skaggs	Universal Technical Services
Dave Mattie	Airforce Research Laboratory
Bob Huie	National Institute of Standards and Technology
John Daniel	National Oceanic and Atmospheric Administration
Bill Waldron	Baker College
Richard Ricker	National Institute of Standards and Technology
Jean Lloyd	Prospective Technology
Carmen DiGiandomenico	Contractor to SAF/AQRE
Joe Macko	CHPPM
Elizabeth Fisher	Cornell University
James Riches	DERA
Steve Watkins	MOD
Jiann Yang	National Institute of Standards and Technology
Bill Grosshandler	National Institute of Standards and Technology
Dick Harris	National Institute of Standards and Technology
Marc Nyden	National Institute of Standards and Technology
Dick Gann	National Institute of Standards and Technology
Linda Blevins	National Institute of Standards and Technology
Ron Sheinson	Naval Research Laboratory
Andrej Miziolek	Army Research Laboratory
Lawrence Ash	Naval Air Systems Command
John Lasalle	
Howard Bausam	CHPPM

The workshop participants reviewed and compared currently used measurement methods for each of these properties and selected the best ones for screening candidates for the next generation of fire suppressants. Each of these “best available” methods was evaluated and given one of the following designations: acceptable as is, acceptable with modifications, or unacceptable. At the conclusion of the workshop, consensus methods were advanced for screening next generation fire suppression candidates for environmental impact, materials compatibility, and toxicity.

Background

Status of the Field Prior to the Workshop

The capability to evaluate the properties of candidate suppressants on a routine basis must be in place in order to carry out an effective search for replacement chemicals. Since a large number of candidates may be advanced, the methods used for screening them must be fast, inexpensive, and require little, if any, chemical. In regards to the latter issue, it should be noted that it is quite possible that many of the compounds that will be advanced as candidates will never have been synthesized before. In addition, successful candidates for the next generation of fire suppressants will have to possess a formidable array of properties. Fortunately, much of the developmental work in this area has already been performed as part of the ongoing search for alternatives to the full range of ozone-depleting substances (1-4). Although these accomplishments would appear to comprise a sound basis for screening candidates, they have not resulted in a set of generally accepted procedures. Therefore, a primary objective of this report is to present consensus methods that NGP researchers can use to obtain consistent and reliable results in screening candidates for their compatibility with people, materials and the environment.

The following is a brief overview of the status of the field at the time that the workshop was convened. This provides the context for the development of the consensus methods, which are presented in the subsequent sections of the report.

Environmental Impact

The contribution of volatile halogenated chemicals to the depletion of stratospheric ozone was the trigger for the latest search for alternative fire suppressants, refrigerants, degreasers, and like chemicals. Thus, early in the process, methods were developed to assess the ozone depletion potential (ODP) of new, halogenated species (4). These methods have become part of the Environmental Protection Agency’s Significant New Alternative Policy (SNAP) Program (5). The major accomplishments of this work were:

- the identification of tropospheric removal processes for airborne chemicals;

- the deduction of reaction mechanisms and the measurement of rate constants and photolytic cross sections which determine whether the chemical in question will survive long enough to reach the stratosphere; and
- the further development of atmospheric models to characterize the transport of chemicals to the stratosphere.

These accomplishments have already been incorporated in the existing set of protocols for screening fire suppressants for environmental impact (1b).

It was soon realized, however, that there might be other environmental threats associated with a chemical and that these would pose a severe problem in the case of compounds with long atmospheric lifetimes (ALs). Global warming potential (GWP) was the pre-eminent one of these. The evaluation of atmospheric persistence involved techniques similar to those for ODP determination. Thus, the screening method remained the same except that, for the case of GWP assessments, it was augmented to account for absorption of radiation in the atmospheric window between 7 and 13 μm . This was accomplished by including a procedure for the measurement of the infrared (IR) absorption cross-section of the candidate over this frequency range. Again, these concepts have been applied to fire suppressants (1c).

Materials Compatibility

A principal objective of the DoD Technology Development Plan for Alternatives to Ozone-Depleting Substances for Weapons System Use (TDP) was to identify the optimal available alternative to halon 1301 for each DoD platform. As part of this effort, extensive work was performed to formalize laboratory methods to obtain performance data on the chemicals under consideration.

It was recognized that, like halon 1301, future suppressants would be stored at elevated pressures and variable temperatures for periods of time on the order of five years or more. In this context, it is important that the stored agent not degrade to products that might be less effective at fire suppression or be harmful to nearby personnel in the event of a discharge. One should also know the potential for the chemical to degrade the integrity of the storage container or any gasket and lubricant materials. Such an interaction could lead to failure of the container, leakage of the agent, and loss of the ability to suppress the fire. NIST developed test methods for these chemical/container interactions for a wide range of candidate chemicals and container metals, gasket materials, and lubricants as part of a DOD sponsored project (1-3,6). We anticipated that this work would provide a sound and sufficient basis for screening next generation candidates for their compatibility with materials and storage stability.

A second concern was the possible harmful interaction of a discharged suppressant and its combustion by-products with ambient materials in the weapons platform.

Methods have been developed and used for this evaluation as well (2,3,6). Those methods and data were generally accepted as the basis for evaluating candidate suppressants and selecting compatible storage container materials.

Toxicity

The safety associated with new fire suppression technologies is paramount. The hazard of the fire threat should not be enhanced by using a “toxic” fire suppressant, where toxic is related to the intrinsic properties of the agent and its combustion byproducts as well as the exposure scenarios involved in its use. The EPA regulates halon replacements in the United States under the SNAP Program (5). The EPA is responsible for assuring that no halon replacement present an unacceptable risk to human health or the environment. Although the EPA has no requirements on screening candidates, the EPA does assess the hazards associated with halon replacement agents by performing a risk characterization. As part of the risk characterization, information on the toxic properties of chemical agents is compiled and combined with the exposure assessment results to estimate risk.

The EPA requests toxicity data on a case-by-case basis for the risk characterization. Because many of the current halon replacement agents have been halogenated hydrocarbons, information related to acute toxicity, cardiac sensitization, subchronic toxicity, developmental toxicity and genetic toxicity have been required. Inert gas agents have had a different set of requirements such as concentration that produces hypoxia. The EPA, however, does not state specific methods to use for these tests. Ideally, the methods used to screen chemicals advanced as fire suppressants will address the endpoints in which the EPA will use to regulate them.

The primary focus of the EPA SNAP program has been to assure the potential for timely egress from the immediate environment generated by the discharge of a fire suppressant. Laboratory methods for toxicity assessments have been developed based on the following metrics:

- NOAEL, the highest concentration at which no adverse toxicological or physiological effect has been observed, and
- LOAEL, the lowest concentration at which an adverse toxicological or physiological effect has been observed.

These criteria are applied with reference to a specified exposure time to the chemical of interest.

For halocarbon agents, cardiac sensitization occurs at lower concentrations than many other toxic effects. Therefore, the focus of the EPA and other standard-setting organizations, such as the National Fire Protection Association, has been on the potential for cardiac sensitization. However, this toxic end point is specific only to certain chemical types such as hydrocarbons and halocarbons. Acute exposures to other chemical class, such as phosphorus-containing chemicals or other inorganic compounds, will focus on other toxic endpoints specific to those particular chemicals. A knowledge of the potential toxic endpoints associated with these chemicals will assist in the development of appropriate screening procedures.

In addition to laboratory measurements, quantitative structure-activity relationships (QSARs) can also be used to predict the toxicity of chemicals. However, because the predictive capabilities of QSARs are based on the quality of the data used in their development and an understanding of the mechanisms of toxicity, these techniques can sometimes be unreliable and should not be the sole criterion for screening decisions. The basic principles behind QSAR technology are well documented and can apply to any class of chemical and any measurable end point (7). Several texts describe the basics of QSAR techniques (8), but briefly, QSARs involve taking a sufficiently large, consistent data set and correlating it with known descriptors of the chemicals within the data set. The correlation techniques are principally multivariate regression and discriminant analysis for weighting descriptors (9). This leads to a mathematical expression, whereby endpoint data can be predicted for chemicals with known descriptors. For example, one can use a data set of lethal concentration values (for example, LC₅₀s) for halogenated hydrocarbons and correlate these values with certain physico-chemical descriptors such as numbers or type of halogens, vapor pressures, and/or octanol-water partition coefficients. The resulting mathematical equation would allow one to calculate the lethal concentration for a new halogenated hydrocarbon knowing only the physico-chemical descriptors for that particular chemical. Several of these approaches are currently being employed in the search for clean fire suppressants (10, 11).

Recently, a compendium of selected current toxicity screening methods was compiled for the US Air Force streaming agent program (12). Although the emphasis of this report was on substitutes for halon 1211, the screening tests could easily apply to general fire suppression candidate down selection. The screening methods addressed in this report focused on acute toxicity/lethality, hepatotoxicity, teratogenicity, cardiotoxicity, and mutagenicity.

Summary of Workshop Presentations and Discussions

Presentations were made on screening methods for the evaluation of environmental impact, materials compatibility, and toxicity. For each property, the workshop participants compared currently used measurement methods and identified the

best method for future use in screening candidates for the next generation of fire suppressants. Each of these "best current" methods was evaluated and given one of the following designations: acceptable as is, acceptable with modifications, or unacceptable. All of the methods reviewed in this section were found to be acceptable with modifications. In those cases where modifications were deemed necessary, specific suggestions for removing the deficiencies were advanced. The following is a summary of the presentations and a review of the issues raised by the workshop participants. The equipment, procedures and results are illustrated using representative slides taken from the presentations.

Environmental Impact

Presentations on screening methods for assessing the environmental impact of candidate fire suppression agents were made by Dr. John Daniel (NOAA), Dr. Robert Huie (NIST) and Dr. Robert Tapscott (NMERL). John Daniel provided a general overview of the problem including working definitions of atmospheric lifetime, ozone depletion potential, and global warming potential. These definitions may also be found in references 1b and 1c. He went on to describe the atmospheric models used to estimate these properties and pointed out some of the limitations of using them as indicators of environmental impact. The major points are summarized in the concluding slide from his presentation, which is reproduced as a text box (to the right of the graphic) in Figure 2.

Bob Huie reviewed laboratory measurement techniques that provide the kinetic and spectroscopic data that are the basis of the models. The flash photolysis resonance fluorescence (FPRF) technique was advanced as a powerful tool for screening next generation suppressants. The major limitation of this approach, which is a characteristic of all kinetic measurements, is that the presence of even trace amounts of a reactive impurity will invalidate the results. The instrumentation for performing FPRF measurements is illustrated in schematic form in Figure 3.

Bob Tapscott presented a summary of the primary atmospheric removal mechanisms for the specific classes of compounds (based on the nature of their chemical constituents) that comprise some of the most promising replacement candidates (Table 2) and outlined a comprehensive protocol for screening these compounds for their environmental impact.

The workshop participants raised the following important issues:

- A further understanding of the tropospheric removal mechanisms and stratospheric chemistry of non-halogenated alternative agents (*i.e.*, reactions involving these compounds that might lead to destruction of stratospheric ozone) is needed in

order to make ODP, GWP and AL assessments on next generation fire suppressants.

- The impact of the agent on ground water, soil and wildlife needs to be taken into consideration.
- The volatility of the agent may be an important factor in determining the environmental impact of next generation suppressants.

Figure 2. Summary of John Daniel's Presentation

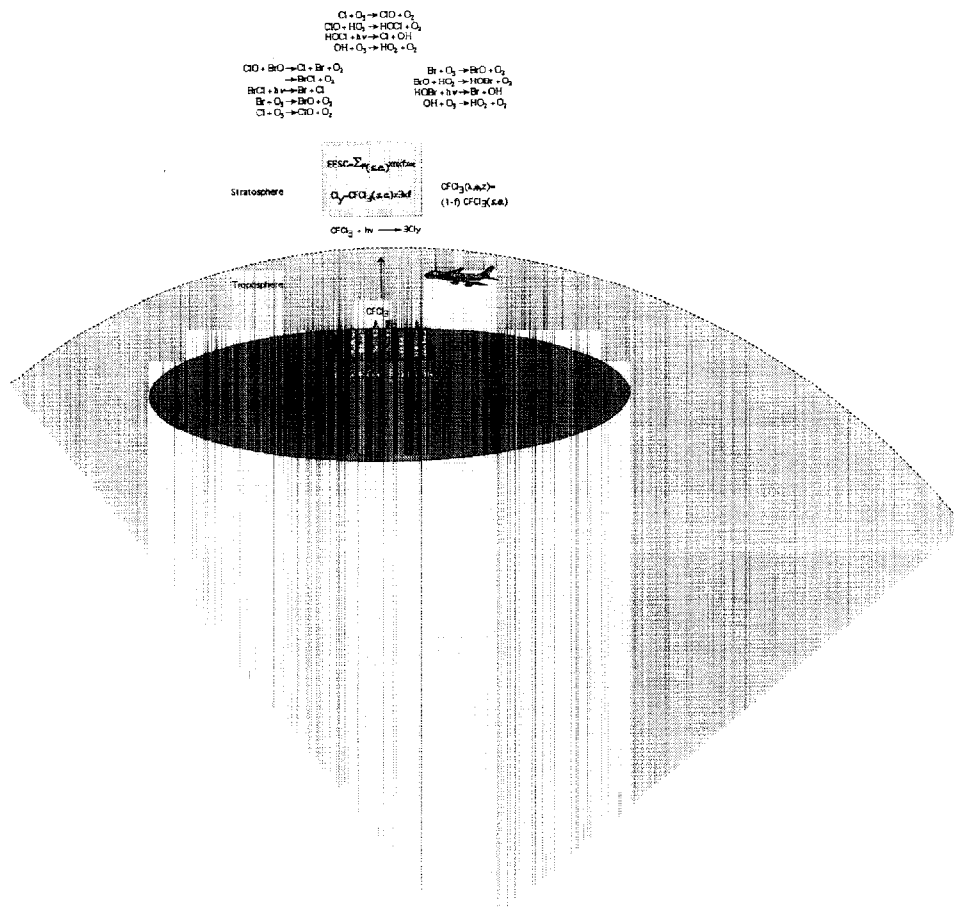

Conclusions

- I. For long-lived trace gases, ODPs and direct GWPs are accurate and effective indices for estimating likely relative impacts on stratospheric ozone and global climate, respectively.
- II. Indirect radiative forcing mechanisms are important in some situations and are generally characterized by higher levels of uncertainty than are direct forcing estimates.
- III. Short-lived trace gases are more difficult to quantify using ODPs and GWPs; this remains an active topic of scientific research.
- IV. ODPs and GWPs are given by simple expressions which cannot account for all atmospheric processes important to ozone depletion and climate forcing; care must be taken in relating these indices directly to ozone depletion and climate change.

Figure 3. Diagram of Flash Photolysis/Resonance Fluorescence Apparatus from Bob Huie's Presentation

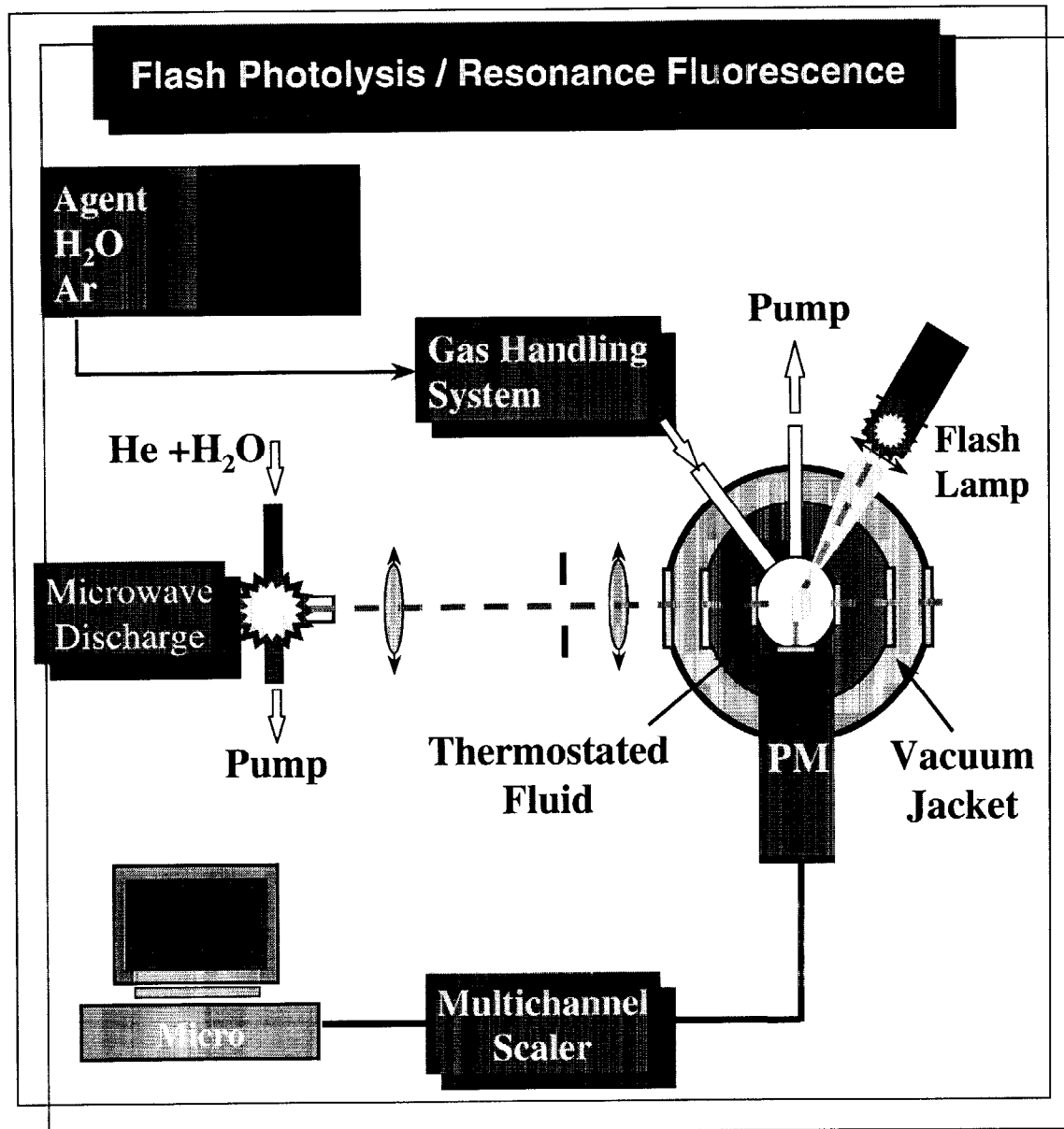

Table 2. Primary Atmospheric Removal Mechanisms for Chemical Families from Bob Tapscott's Presentation

Primary Removal Mechanism	Example Families
Reaction with Hydroxyl	Hydrogen-Containing Compounds, Alkenes, Aromatics
Photolysis	Iodides, Carbonyls, Bromides
Physical Removal	Ketones, Alcohols, Esters
Reaction with Tropospheric Ozone	Alkenes
Thermal Decomposition	Reactive Molecules (e.g., Epoxides, Peroxides)
Hydrolysis	Compounds with Direct Silicon to Halogen Bonds, Carbonyl Halides

Materials Compatibility

Presentations on screening for materials compatibility were made by Mr. Richard Harris (NIST), Dr. William Waldron (Baker College), and Dr. Richard Ricker (NIST). The procedures, which are based on standard ASTM test methods, are described in detail in references 1-3,6.

Dick Harris presented an overview of a screening method for assessing agent stability under long-term storage. The protocol consists of storing the agent in a cylinder containing coupons of the metals to be tested at an elevated temperature (as high as 150 °C in some experiments) for a period of time ranging from several weeks to a year. An elevated temperature is used to accelerate the aging process and, thereby, to simulate the effects of long-term storage in, what would otherwise be, an artificially short period of time. Samples from the headspace of the cylinder are extracted at scheduled intervals to monitor changes in the mid-infrared spectrum of the agent during the course of the test. Storage stability is assessed on the basis of observed changes in the spectra and by visual inspection of the coupons, which are removed from the cylinders at the conclusion of the test. The screening method was demonstrated using the results obtained with two candidate suppressants, FC-218 (CF₃CF₂CF₃, perfluoropropane) and CF₃I. A comparison of the spectrum of CF₃I, measured before and after the accelerated aging, showed clear signs of degradation (Figure 4), whereas the spectrum of the fluorocarbon was unaffected by the simulated aging process.

The next speaker was Bill Waldron, who summarized a series of screening methods for agent compatibility with polymeric materials. In these tests, selected polymers are exposed to an atmosphere containing the candidate suppressant in a pressurized vessel. The results obtained in the process of screening candidate suppressants for compatibility with greases, lubricants, and elastomers were presented. The first method described by Dr. Waldron was a swelling test, which is based on the extent to which the agent is absorbed by the polymer. The performance of representative elastomers (Table 3) exposed to a series of hydrofluorocarbon agents is presented in Table 4. The underlying assumption is that the performance of the material will degrade in direct proportion to the amount of agent it absorbs. The uptake of the agent by the polymer is determined by measuring the deflection of a quartz spring secured to a pan that supports a sample of the material (Figure 5). Three test methods, which were designed to provide a more direct measure of the effect of agent exposure on the mechanical durability of the materials, were also described. These tests involved making measurements of the compression set, tensile strength, and viscosity of polymer samples exposed to known concentrations of the agents for predetermined periods of time at a series of temperatures. In the compression set tests, the thickness of a compressed polymer sample is measured and the compatibility of the material with the agent is expressed in terms of the percentage of the deflection retained after release from compression. In the tensile tests, samples of the materials are stretched until they rupture. The compatibility is judged by the extent to which exposure to the agent decreases the maximum elongation length. In the viscosity tests, the rheological properties of a series of lubricants are measured after high temperature (150 °C) exposures to the candidate suppressants. Although the original data obtained by Waldron and co-workers (2d) did not show a systematic variation with exposure time, a qualitative assessment of compatibility was formulated based on the appearance (or absence) of a powder-like phase after exposure to the agent for a specified period of time.

Rick Ricker (NIST) presented an overview of screening methods for the assessment of agent compatibility with metals. He began by describing the effects of corrosion on metals. The modes of failure, which are of the most concern with respect to the storage, distribution, and deployment of fire suppressant agents in aircraft and other weapons systems, were identified. These are: uniform corrosion (also known as general corrosion), pitting corrosion, intergranular corrosion, dealloying corrosion, crevice corrosion, and stress corrosion cracking (also referred to as environmentally induced fracture). The test methods were evaluated using coupons made from 5 common metal alloys. An immersion test, conducted by exposing the coupons to a pressurized atmosphere containing the candidate suppressant (gas phase), was recommended for the assessment of all of the listed modes of failure except for stress corrosion cracking. The deterioration of the sample is judged on the basis of weight-loss measurements and by visual inspection of the coupons. The susceptibility to crevice corrosion, which is characterized by a localized reaction at an occluded region, was determined by

substituting a u-bend coupon for the flat coupon used in the other determinations. A slow strain rate tensile test, conducted by applying a load along the cylindrical axis of a threaded coupon was recommended for the evaluation of stress corrosion cracking in metals exposed to candidate suppressants. The test chamber and coupon are displayed in Figure 6.

Table 3. Elastomers and Lubricants Used in the Polymer Swelling Evaluation Tests from Bill Waldron's Presentation.*

Material	Vendor	Designation
Silicone	Colonial Rubber	Si
55 % Butadiene - 45% Acrylonitrile	Goodyear	N206
Fluorosilicone	Colonial Rubber	FSi
Viton E-60 Fluorocarbon	Du Pont	FKM
Neoprene	Colonial Rubber	CR
85% Butadiene - 15% Acrylonitrile	Goodyear	N926
Krytox 240AC Fluorinated Grease	Du Pont	240AC
Braycote 600 Perfluoropolyether Grease	Castrol	600
Braycote 807 Aircraft Grease	Castrol	807

There was a consensus that the uniform and stress corrosion tests were the most revealing of the laboratory protocols that were reviewed for assessing agent compatibility with metals. A number of participants suggested that the durability protocols (*i.e.*, compression set, tensile, and viscosity tests) described by Waldron for assessing agent compatibility with plastics might be replaced by a performance related test such as a cylinder leak test. There was no criticism of the polymer swelling test, which appears to be adequate for the purpose of assessing the compatibility of gasket materials with the

* Certain commercial equipment, instruments, materials, services or companies are identified in this report in order to specify adequately the experimental procedure. This in no way implies endorsement or recommendation by NIST.

agent.

Table 4. Results of the Polymer Swelling Measurements from Bill Waldron's Presentation. The labels refer to the compatibility of the lubricants and crosslinked elastomers with respect to the specified fluorocarbon agents at 35 °C.

The workshop participants noted several deficiencies in the test method for storage

Agent	240AC	600	807	Si	N206	FSi	FKM	CR	N926
HFC-236fa	good ^a	good	good	fair ^b	fair	bad ^c	bad	bad	bad
HFC-32/125	good ^d	good	good ^d	fair	good ^d	good	good	good	good ^d
HFC-227ea	fair ^e	fair	fair ^d	fair ^e	good ^d	fair ^e	fair ^d	good ^e	bad
HCFC-22	fair	good	fair	fair	bad	fair	fair	good	bad
HFC-134a	good	fair	good	fair	good	fair	good	good ^d	good
FC-116 ^f	fair	fair	fair	good ^e	good ^d	good	good	good ^d	good ^d
HCFC-124	good ^d	good ^d	good	bad ^d	fair ^d	fair ^d	fair ^d	fair ^d	fair ^d
HFC-125	fair	good	good	good	good	good	fair	good	good
FC-218	good ^d	good	good	good	good	good	good	good	good
FC-31-10	fair	bad	bad	fair	fair	good	fair	good	fair
FC-318	fair	fair	fair	good	good	good ^a	good	good	fair

^a $\chi > 1.2$

^b $0.9 \leq \chi \leq 1.2$

^c $\chi < 0.9$

^dmeasured at 5 °C

^e $12.5 < CV < 20\%$ and $0.64 < \chi < 1.5$

^f $CV > 20\%$

stability, but concluded that it would be acceptable if some modifications were introduced. In particular, it was noted that the existing method did not attempt to simulate abrupt fluctuations in temperature and pressure (cycling) that agents used in aircraft suppression systems would be subjected to during take-off and landing. Furthermore, it was observed that the practice of sampling the headspace, rather than the condensed phase of the cylinder contents, would preclude detection of nonvolatile degradation products.

Figure 4. Difference Spectrum of “Aged” CF_3I from Dick Harris’ Presentation

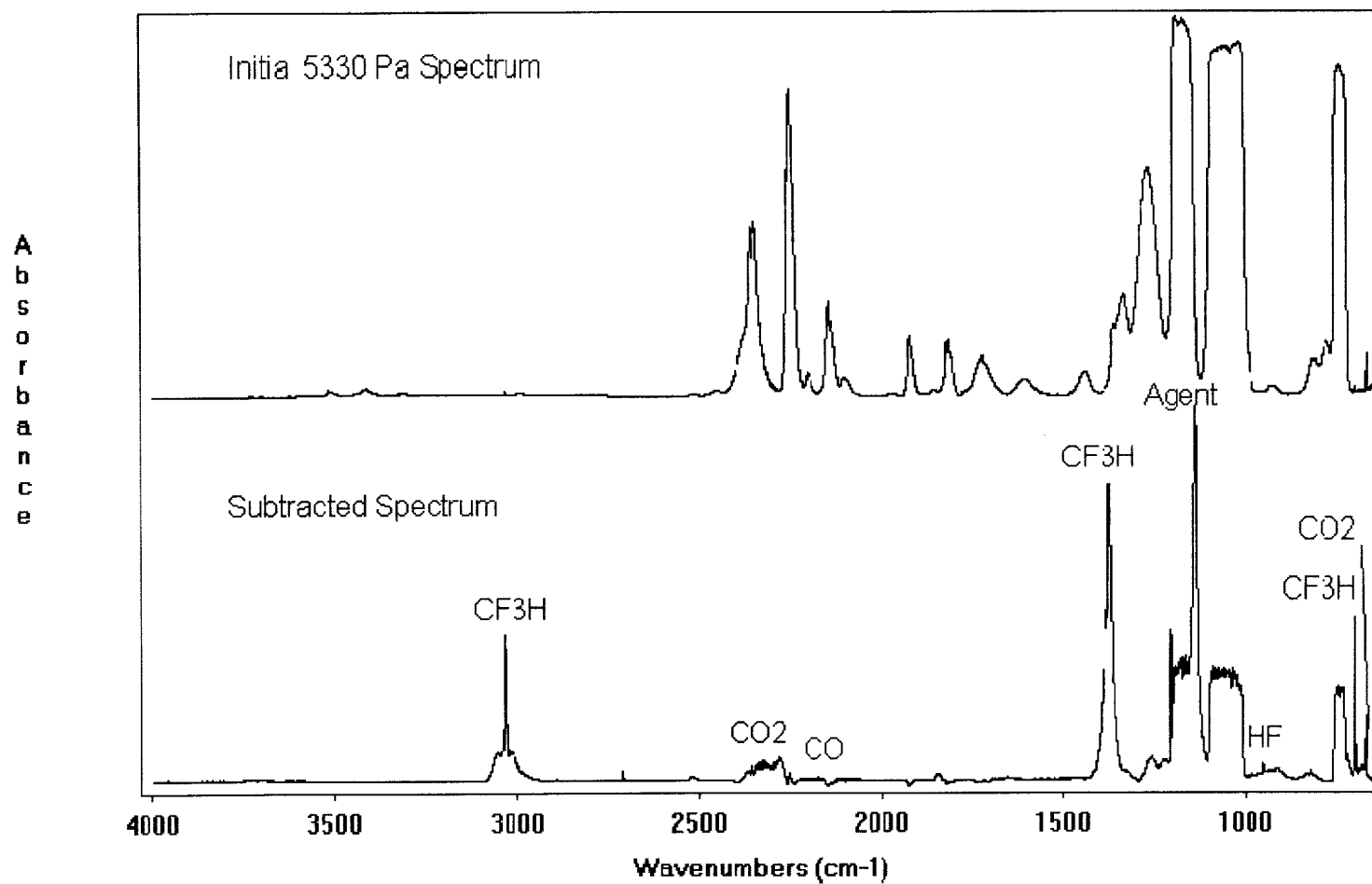

BLANK PAGE

Figure 5. Diagram of Polymer Swelling Apparatus Tests from Bill Waldron's Presentation

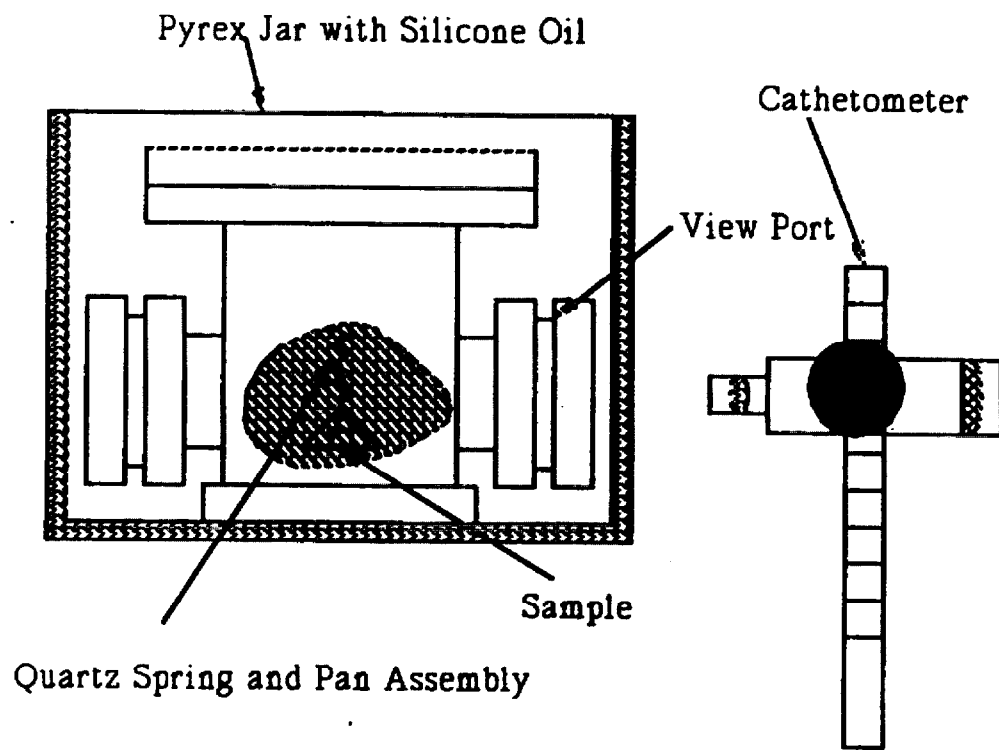
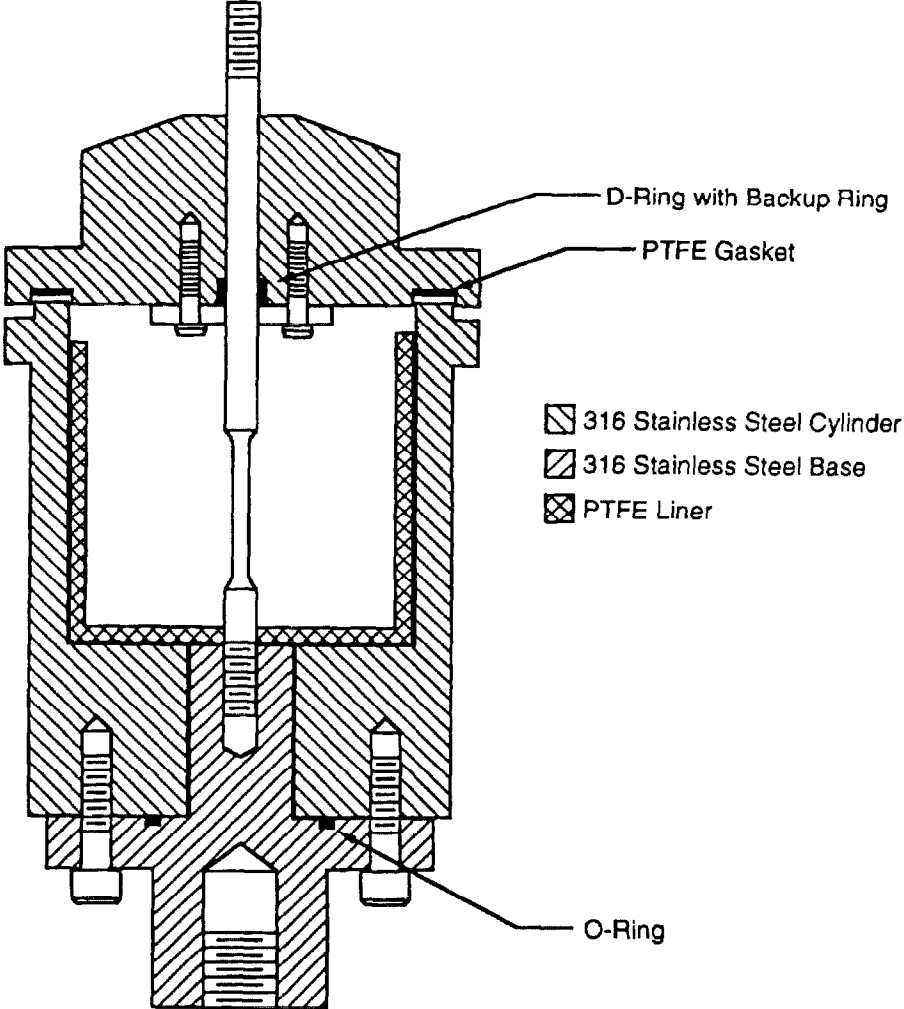

Figure 6. Test Chamber and Coupon for the Slow-Strain Rate Tensile Test Apparatus from Rick Ricker's Presentation



Toxicity

Ms. Stephanie Skaggs (Universal Technical Services, Inc.) made the first presentation in the section on screening for toxic potential of chemicals. She provided a historical perspective of halon toxicity testing, the more recent halon replacement testing requirements, and the future methodologies for assessing agent compatibility with people (Figure 7). Dr. David Mattie (Air Force Research Laboratory-Toxic Hazard Division) presented an overview of the tiered risk assessment process as well as a summary of toxicological tests (Figure 7). The point was made that even though a summary of toxicological tests was presented, this was not an indication that it was a checklist to be used in a "cookbook" fashion. Expert judgment is needed to interpret the results of each test and decide what, if any, additional testing is necessary to evaluate the health effects of new agents. Even though a distinction was made between screening tests, which are meant to assist in the down selection process, and evaluation and analysis tests, which are meant to fully assess the toxic potential of chemicals and to provide input into the risk assessment process, the same toxic endpoints that are assessed in the evaluation and analysis phases of research can be screened during the down selection process. Therefore, although the presentations showed a variety of toxicity tests that were available for testing, the focus of the workshop was on procedures that could be used as screening tests for the same or similar endpoints as would be addressed in the toxicity evaluation.

All workshop participants had a strong sense that as much up-front, theoretical work should be done as possible prior to undertaking any experimental screening tests. This "pen & paper" approach should include performing literature searches for physical properties, prior toxicity evaluations, and regulatory controls. Subsequent predictions of activity can then be based on chemical group determination and structure analogies.

Quantitative structure activity relationships (QSARs), where possible, were seen as an interim step between the "pen & paper" phase of evaluation and the experimental screening steps. The QSAR methodology is well documented and the principles behind applying specific QSAR models pertain to all chemical classes (7,8). In principle, QSARs can be developed for nearly any property, measurable endpoint, or effect as long as a sufficiently large data set of known parameters exists for the chemical family to which the compound of interest belongs. One of the objectives of the literature search is to determine the extent and range of applicability of the data on structurally related compounds.

The workshop participants concluded that although the methodology for performing QSARs is adequate, not all of the data needed to perform QSAR analyses on the chemical classes that are, or will be, investigated as new fire suppressants is available. The distinction was made between developing the screening method itself, *i.e.*, a technical approach, and applying the already developed method to specific data sets. The

former has been done, whereas the latter may still need to be performed for specific chemical sets. This can be thought of as analogous to calculating ozone depletion potential where the method for calculating such values is known, but the data used in the actual calculations may not be compiled or measured.

The experimental screening methods that were identified for evaluating compatibility with people included: limit tests, which generally study non-specific toxicological endpoints or effects, and in vitro methods, which can be designed to investigate specific effects. The methodology for performing a limit test is available and adequate (13). However, the exposure duration and concentration aspects of the limit test protocol may need to be tailored specifically to address issues related to fire fighting agents. A traditional limit test involves exposing rats to a single dose of chemical and determining whether this dose is lethal.

The workshop participants concluded that a number of in vitro or "test tube" methods also existed to evaluate certain toxicological effects of chemicals. In vitro tests are distinct from the limit test because the limit test addresses a general, non-specific and whole-body effect, whereas in vitro tests are quite specific to the cells or tissue and the toxicological effect being studied. For example, in vitro methods exist for determining the mutagenic potential of chemicals (14-16), the ability to inhibit cholinesterase activity in nerve cells (18), the arrhythmogenic potential of chemicals in cultured myocardial cells (19, 20), to name a few. Although in vitro methods may not exist for all the endpoints of interest in the development of new fire suppression technologies, the participants addressed the cost (and time) benefit issues surrounding development of new screening methods. The workshop participants concurred that the time, effort, and funds needed to develop and validate new in vitro screening methods were beyond the scope of the NGP program.

In summary, the workshop participants agreed that a tiered approach to people-compatibility issues, which takes into account the risk of exposure in specific scenarios as well as the inherent toxicological properties of the materials, is needed. This is being addressed in a complementary NGP project conducted by Mantech Environmental Technologies (Dayton, OH). Screening methods currently exist to aid in the down-selection of a large number of chemicals to a fewer number of candidates. Once the current state of knowledge is investigated for a particular chemical or a general chemical class, QSARs, which are a non-experimental approach to down-selection, may be applied. Limit tests and in vitro methods are experimental approaches. Limit test protocols can be adapted to study particular aspects of chemicals in question. A number of in vitro tests currently exist to evaluate specific effects of chemicals on cell or tissue preparations. However, the available in vitro tests are not sufficient to screen all aspects of chemical toxicity effects. Nonetheless, the costs, in terms of time and money, make developing new methods beyond the scope of the NGP.

Figure 7. Toxicity issues pertaining to next generation fire suppression candidates adapted from Stephanie Skaggs presentation.

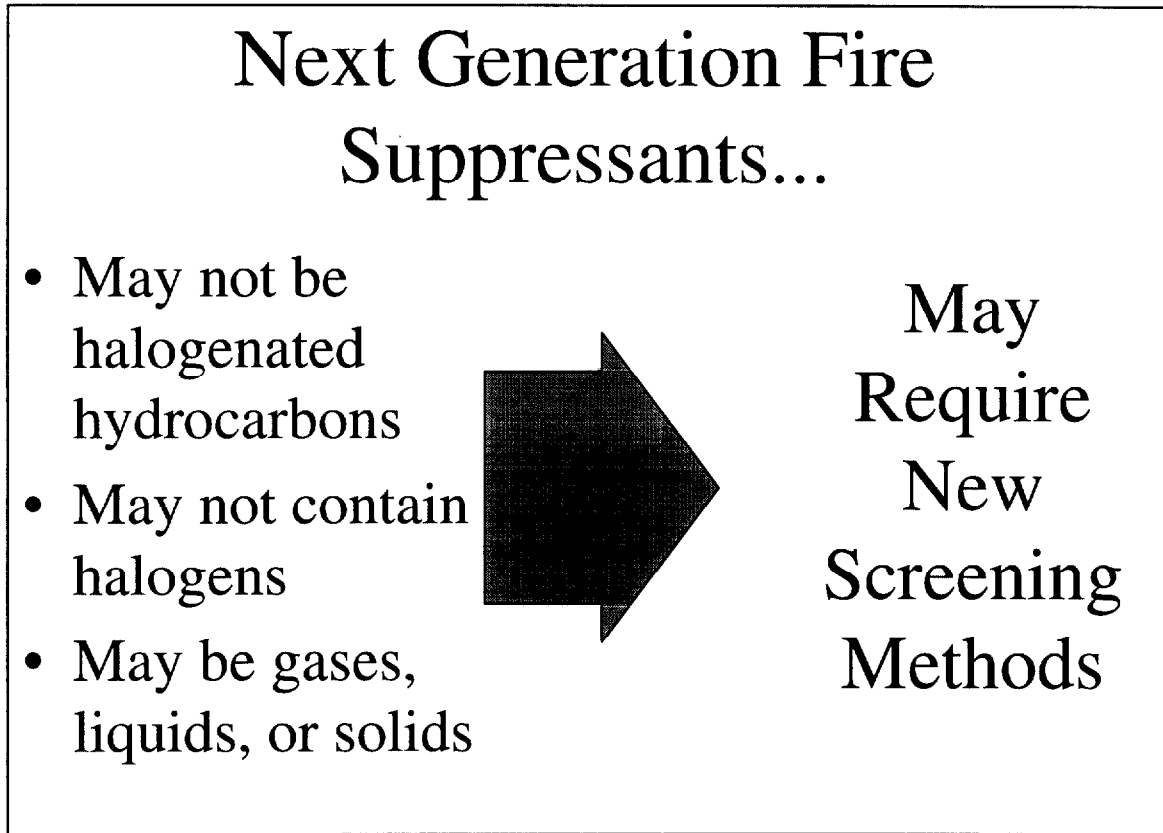

RISK ASSESSMENT

<u>EXPOSURE ASSESSMENT</u>	<u>HAZARD ASSESSMENT</u>	<u>RISK CHARACTERIZATION</u>
Identify Potential Exposure	Perform Additional Toxicity Testing As Needed	Look at Exposure and Hazard Assessments plus Dose Response
Determine Exposure Level & Duration	Investigate Biochemical Mode of Action	DoD System Requirements and Options
Collect Available Tox Data; Determine Deficiencies	Develop Methods For Extrapolation, Animals Humans High Dose Low Dose	Development Of Regulatory And Operational Guidelines

Figure 8. Overview of the Tiered Risk Assessment Process adapted from Dr. Dave Mattie's Presentation

- **Tier 1 - Acute Toxicity and Genotoxicity Screens**

 - Acute Toxicity

 - Genotoxicity I

- **Decision Point 1.**

 - Replacement candidates that are minimally/mildly toxic in rats following acute exposure and are either negative or minimally/mildly genotoxic in bacteria become candidates for Tier 2 testing.

- **Tier 2 - Range Finder, Genotoxicity, and Cardiac Sensitization Tests**

 - Range Finder

 - Genotoxicity II

 - Cardiac Sensitization

- **Decision Point 2.**

 - ODC replacement candidates that are minimally/mildly toxic in rats following repeated 14-day exposure; are either negative or minimally/mildly genotoxic in mammalian somatic cells; and are negative or minimally potent cardiac sensitizers become candidates for Tier 3 testing.

- **Tier 3 - Subchronic Toxicity and Genotoxicity Tests**

 - Subchronic Toxicity

 - Genotoxicity III

 - PBPK Model

- **Decision Point 3.**

 - ODC replacement candidates that are minimally/mildly toxic in rats following repeated 90-day exposure and are either negative or minimally/mildly genotoxic following the *in vivo* mammalian micronucleus assay become candidates for Tier 4 testing.

- **Tier 4 - Reproductive Toxicity, Developmental Toxicity, and Tumor Bioassay**

 - Reproductive Toxicity

 - Developmental Toxicity

 - Tumor Bioassay

- **Decision Point 4.**

 - RISK ASSESSMENT**

Consensus Screening Methods

Procedures

At the onset of the discussions, some of the participants expressed the opinion that screening of next generation candidates, which are expected to represent a wide range of compounds with diverse physical, chemical, and toxicological properties, could not be performed in "cookbook fashion" from a checklist of predetermined procedures. The predominant view was that such an approach would constitute a severe oversimplification of the inherent difficulties and uncertainties involved in making performance appraisals, especially with regards to toxicity, on new, and in many cases, unfamiliar compounds. A consensus was reached only after the workshop moderators reminded the participants of the distinction between screening tests and evaluation/analysis tests. This distinction has been emphasized throughout this report and has provided the framework for the strategy to candidate screening.

The consensus screens were developed by revising the methods, which were identified as being the best available by the workshop participants, to account for problems that might be encountered in applying them to next generation candidates. Each of these methods consists of a series of property predictions and/or evaluations to be performed in a prescribed order. Further documentation is provided in the accompanying references.

Environmental Impact

The consensus screen for environmental impact is illustrated as a decision tree in Figure 8. Further revisions may be made as the results of another NGP project (4B/3/8), which is investigating the environmental consequences of some of the more promising next generation candidates, become available. In the judgement of the majority of the workshop participants, the most efficient implementation strategy for screening candidates is a hierarchical approach incorporating the following elements:

- A literature search, to be performed in conjunction with the toxicity screen, for properties, such as boiling point and solubility, which are relevant to the task of assessing the likely impact of the candidate on the atmosphere, water, soil and wildlife;
- structure-activity based predictions of the reactivity of the candidate in the troposphere and in ground waters, which determine its atmospheric lifetime;

- laboratory measurements of rate constants and absorption cross-sections; and
- detailed atmospheric modeling, when more reliable estimates of the atmospheric lifetime, ODP, and GWP of the candidate are required.

What follows is an expanded summary of the decision points that comprise the screening protocol. Documentation for the techniques used in the property evaluations may be found in the references included in the description of each method.

The first step in assessing the likely environmental impact of the candidate suppressant is to conduct a literature search for its chemical, physical, and toxicological properties. The existing applications of the compound and any regulations restricting its use should be noted at this time, since they might reveal relevant properties. The boiling point is of particular interest, since it will determine if it is necessary to perform a more detailed study of the atmospheric reactivity of the candidate. Compounds with high boiling points (greater than ~ 100 °C) would be expected to have a more significant impact on water, soil, and wildlife than on the atmosphere and should be screened accordingly.

Environmental impact assessments of low volatility candidates should be based on their octanol-water partition coefficients (P), which can be measured by liquid chromatography (21). Information about hydrolysis rate constants and other degradation pathways, including complexation with transition metal ions (and subsequent photodegradation), and substitution reactions (e.g., with chloride ions) may also have to be considered for compounds which are sufficiently lipophilic ($P > P_l$) to penetrate cell membranes but not so much so ($P < P_u$) that they become dissolved in the fat layer without reaching their biological targets (22). Laboratory methods for assessing the relative importance of these removal mechanisms for specific classes of compounds are currently under investigation in another NGP sponsored research project (4B/3/8).

The EPA has developed a number of QSARs useful in estimating the toxicity to aquatic organisms based on octanol-water partition coefficients (23). The QSARs can be applied to neutral organics with or without reactive and ionizable units or surface-active functionalities. One example is ECOSAR (Ecological Structure Activity Relationships), which is a computer program for estimating the toxicity of chemicals used in industry and discharged into water (24). This program makes use of structure activity relationships in estimating the acute (short-term) and, when available, the chronic (long-term or delayed) toxicity of industrial chemicals to aquatic organisms such as fish, invertebrates, and algae. ECOSAR can be downloaded from the EPA's website at the following url: (<http://www.epa.gov/opptintr/cbep/actlocal/21ecosar.htm>).

MED-Duluth tested a series of industrial organic compounds using the fathead minnow for the purpose of developing an expert system to predict the acute mode of toxic action from chemical structure. The results were also used to develop quantitative structure-activity relationships based on the acute mode of action. The expert system and QSARs are components of the ASTER system. The entire fathead minnow database and results related to the acute mode of action are presented in reference 25. This data file includes information on the test chemical, Chemical Abstract Services Registry number, the SMILES string, results of 617 acute LC₅₀ values and 225 associated behavioral assessments, 72 joint toxic action experiments with the fathead minnow, and physiological response of rainbow trout (also called Fish Acute Toxicity Studies (FATS)) for 17 compounds. A copy of the database is available for distribution from Chris Russom (T: 218-529-5218 or E-mail: russom.chris@epa.gov).

In the case of volatile compounds, the focus of the screen should be on their reactivity in the atmosphere. The atmospheric lifetimes of all vapor phase candidates should be estimated. This can be accomplished either by using structure-activity relationships or by direct laboratory measurements, depending on the required level of accuracy. A minimum criterion for the down selection of a candidate, is that it have an atmospheric lifetime less than HFC-125, which is on the order of 30 years (26). This criterion is based on the fact that this compound has gained acceptance for use aboard some military aircraft even though it is generally recognized that is a factor of 2 to 3 less efficient in suppressing fires than halon 1301. The most significant tropospheric removal mechanism for compounds with C-H bonds is usually hydrogen abstraction by hydroxyl (OH) radical. However, hydrolysis and reactions with other atmospheric oxidants, particularly ozone (27), may also be important. Information on the UV-VIS absorption cross-sections of the candidate and related compounds should also be sought in order to establish the importance of photolysis as a mechanism for atmospheric removal. The IR absorption cross-section in the atmospheric window, which extends from about 7 μ m to 13 μ m, may also be needed in order to estimate the GWP of the candidate (1c).

Rate constants for the reaction with OH and the corresponding atmospheric lifetimes (t_{OH}) can be estimated for a wide range of compounds, including halocarbons, by QSARs based on group additivity. This approach is described in detail in Appendix B of references 1b and 1c. If, on the other hand, the candidate is a member of a chemical group for which information on OH reactivity is not available, its atmospheric lifetime can be estimated using the method described in reference 28. Methods for calculating the C-H bond dissociation energies, which are the required input data, are described in references 2a and 29. Finally, in cases where more reliable data are required, a direct measurement of the rate of reaction with OH can be made using the flash photolysis/resonance fluorescence technique, which is summarized in references 1b and 1c.

The lifetime due to photolysis (t_{photo}) should be estimated for those compounds that are not effectively removed from the troposphere by reaction with OH radical. Fortunately, there exists an ample body of data indicating that the magnitude of the absorption cross-section for visible radiation can be correlated with the number, position, and type of halogen atoms in the molecule (1b,1c). This, along with similar observations made with respect to the presence of other chromophores (30), provides the basis for the development of QSARs for the atmospheric lifetimes of compounds that undergo photolytic decomposition in the troposphere. Spectroscopic measurements of the UV/VIS absorption cross-sections, as described in Appendix B of references 1b and 1c, can be made to obtain more reliable estimates of the lifetimes of photo-reactive candidates.

Rate constants and the corresponding lifetimes ($t_{\text{H}_2\text{O}}$) for the hydrolysis of a wide range of organic compounds are tabulated in reference 31. These data provide a basis for the development of structure-activity relationships for the estimation of $t_{\text{H}_2\text{O}}$ in candidate suppressants. The experimental procedures for making these measurements, which might be useful in the formulation of a laboratory screen for hydrolytic activity, are also delineated in the references included in this comprehensive review.

Reaction with tropospheric ozone may be important for candidates which have one or more double bonds. In fact this reaction, which is known as ozonolysis, was routinely used in the characterization of alkenes (*i.e.*, in verifying the existence and determining the locations of double bonds) before the advent of modern instrumental methods (32). Since the reaction is very specific (*i.e.*, O_3 reacts slowly with alkynes and immeasurably with alkanes), this mode of removal can be ignored unless the candidate is an alkene (27), in which case it is likely that the reactivity with OH will also be high.

Other removal processes, including physical removal (*i.e.*, rainout, aerosol scavenging and solvation), may have to be taken into consideration. In some special cases, removal by $^1\Sigma \text{O}_2$ in the troposphere and/or by $^1\text{D O}$ in the stratosphere may also have to be considered for candidates that are not effectively removed by the mechanisms delineated in the previous paragraphs. Methods for estimating lifetimes due to physical processes are discussed in reference 27.

The GWP of a compound depends on its atmospheric lifetime and on its ability to absorb radiation in the atmospheric window extending from about $7\mu\text{m}$ to $13\mu\text{m}$. Compounds which are weak absorbers in this spectral region do not contribute significantly to global warming. Again, HFC-125 provides a benchmark value for the maximum, acceptable GWP. This value, which is reported as 0.58 in reference 33, should be used only in deciding whether to pursue further research on candidates and not for regulatory purposes. A qualitative assessment of GWP may be made on the basis of characteristic group frequencies, which are tabulated in standard texts (see for example reference 34). A more rigorous screen, which makes use of information on both the atmospheric lifetime and infrared absorption of the compound, is detailed in reference 1c.

Atmospheric modeling, using measured rate constants and absorption cross-sections, can be performed when more reliable estimates of GWP are required.

The ODP of a compound depends on its atmospheric lifetime and on the number and kinds of atoms that it contains. Halogen atoms, in particular, are known to undergo catalytic cycles that deplete stratospheric ozone; with Br and I being the most efficient and F having essentially no catalytic activity. Candidate ODPs can be estimated on the basis of QSARs as described in reference 28 for the case of hydrochlorofluorocarbons. A screen based on the atmospheric lifetime and the presence of halogen atoms is detailed in reference 1b. The question of whether atoms other than Cl, Br and I can play a significant role in ozone depletion is currently under investigation in another NGP project (4B/3/8). For the time being, investigators should be wary of any candidate containing halogens with a lifetime exceeding 1 year (even the presence of fluorine, which does not play a role in the depletion of stratospheric ozone, may be sufficient to exclude the candidate because C-F bonds are strongly absorbing in the atmospheric window, so that compounds containing fluorine atoms usually have high GWP's). Atmospheric modeling using measured rate constants and absorption cross-sections is recommended for otherwise promising candidates that contain halogen atoms.

Materials Compatibility

It was clear to the workshop participants that the results of applying materials compatibility measurements on a wide range of metals and plastics indicated that it should almost always be possible to find suitable materials for storage of specific agents even though not all materials will be appropriate for all agents. On the basis of this observation, we have concluded that there is no need to screen every candidate for its compatibility with metals and elastomers. Instead, we recommend performing materials compatibility screening only when there is reason to suspect, either on the basis of the results of the literature search and/or structure-activity analogies, that the instability and/or reactivity of a candidate may be severe enough to preclude its eventual use as a fire suppressant. The consensus screening method is summarized as a decision tree in Figure 9.

The first step in the screening process is to conduct a literature search for the chemical and physical properties of the agent. The ambient state of the agent is an important factor in determining its potential for interaction with both metals and polymers. Thus, all other things being equal, a liquid would be expected to have a greater impact on the properties of materials than would a gaseous or solid agent. Likewise, the potential for instability increases if the agent can hydrolyze into more reactive products, such as HF or HCl, or even if it is water soluble.

If the literature search indicates a potential for instability, then a more detailed appraisal is warranted. This process is initiated by classifying the candidate according to its important chemical and structural features, which will facilitate the identification of probable reaction paths and provide a basis for structure-activity based predictions of its storage stability. The compatibility of the agent with polymers and metals, both of which are used in the storage environment, is of interest. QSARs for the permeability of polymers with respect to small molecules are described by Bicerano in reference 35. This methodology can be used, in conjunction with the data obtained for the interactions between halocarbon suppressants and a wide range of polymers reported in references 2d and 6b, to make predictions of materials compatibility with next generation fire suppressant candidates. Although we have not specifically considered any structure-activity relationships for the prediction of corrosivity, it makes sense to recommend that the potential for corrosive interactions between the agent (as determined by the chemical properties of its functional groups) and various metals and metal ions should be examined. It is important to note in this context, that the ability of some materials to withstand the effects of corrosion derives from the nature of their degradation products, rather than from their intrinsic stability. This is the case with stainless steel, which in the presence of water, forms an insoluble film that protects the underlying metal from further corrosion [36]. Thus, the propensity of the metal/alloy to form insoluble complexes in the storage environment, which can pacify the surface and thereby inhibit attack by the agent, should be explored up front. Having determined the importance of this effect, the investigator should then perform an assessment of relative thermodynamic stability, as indicated by free energy or electrochemical differences between the agent and the metal/alloy.

Finally, the accelerated aging protocol summarized in the previous section of this report can be employed in cases where a more reliable appraisal of the potential for catastrophic failure during storage is required. Indeed, if the primary objective is to determine whether the candidate can even be stored, then the amount of time required for aging can be reduced to a couple of days, as opposed to the many months which was needed to ascertain the storage stability of CF_3I . This time frame is more consistent with what is expected of a screen. The procedure described by Harris should, however, be modified to simulate temperature and pressure cycling in order to account for the effects of phase transitions (*i.e.*, condensation and evaporation) that would be expected to occur during aircraft take-off and landing. This can be accomplished by periodic heating and cooling of at least one cylinder containing the candidate. The deviations from the mean testing temperature should be determined on the basis of expected pressure variations. The procedure should also be augmented to include an analysis for condensed phase degradation products by IR and/or GC/MS techniques. This analysis can be conveniently performed in conjunction with visual inspection of the material samples at the conclusion of the storage period. We also recommend using smaller cylinders, which would reduce storage requirements during testing.

Although the participants agreed that the further development of a routine screen for the down selection of candidates on the basis of their compatibility with storage materials would not be necessary, they did recognize that there would still be a need to screen candidates for their potential to cause catastrophic damage to platform construction materials. One of the participants suggested the possibility that existing ASTM test methods might be adequate for this purpose. In fact, there is an ASTM procedure for assessing the effects of solvents on titanium (37), which can be used for this purpose. The environmentally induced failure screen outlined by Ricker, however, is better suited for gauging the interactions of agents with metals and alloys other than titanium and should be performed whenever the literature search and/or QSAR analysis indicates that the weapons platform may be damaged by exposure to the agent. The criteria for environmentally induced fracture are based on measurements of ultimate tensile strength (UTS) and ductility, as indicated by measurements of engineering strain to failure (STF) and reduced cross-sectional area (RA), in the slow-strain-rate (SSR) tensile test. A statistical approach to ranking candidate fire suppressants with respect to their propensity to stress-corrosion cracking is presented in reference 38.

The likelihood of damage due to exposure to the combustion by-products of the agent, which would only be produced when the agent is deployed to extinguish a fire, can be predicted on the basis of structure-activity relationships. Thus, compounds containing halogen atoms or other reactive moieties might be expected to generate corrosive by-products when exposed to the high temperatures and oxidative environments that prevail in the environment of a fire. The relative rankings with respect to their steady state HF production rates (2a) provides a point of departure for a more quantitative assessment of the potential in the case of halocarbons. A post deployment screen for corrosion damage to aluminum and other aircraft alloys, which was developed by Stoudt *et. al* (6a), may be performed in cases where the results of the QSAR analysis are inconclusive.

The polymer swelling and general corrosion tests described by Waldron and Ricker may be useful in identifying optimal storage materials for the most promising candidates. When used in this context, they would be performed only at the conclusion of the selection process and, therefore, should not be considered as part of the agent screening processing. Nevertheless, these procedures may still be of considerable value to the NGP program. The assessment of compatibility using the polymer swelling protocol is made on the basis of the value of the Flory-Huggins polymer-solvent interaction parameter, χ (reference 39,40). Small values ($\chi < 0.5$) correspond to complete miscibility of the agent in the polymer at all concentrations. Large values ($\chi > 1.2$) suggest limited solubility and, as a consequence, good compatibility. A value of 0.9 was considered to be a lower bound to acceptable compatibility based on empirical observations. The effects of general corrosion can be evaluated on the basis of the observed weight-loss (WL) measurements. Thus, a metal should be rejected if its rate of weight loss, as determined in

the test method, indicates that components made from it might fail within the expected 5 year service period for the distribution system.

Toxicity

Although the selection of chemicals with low toxicity is of paramount importance, toxicological testing can be extremely expensive. Consequently, an emphasis should be placed on reliable theoretical screening methods that can be performed prior to any laboratory measurements. It should be stressed, however, that even the most rigorous, non-experimental screening does not obviate the need to perform laboratory measurements when accurate determinations of toxic potential are required. The "pen & paper" screening approach should include an extensive literature search for physical properties, prior toxicity and epidemiology evaluations, and regulatory controls. This aspect of the screening process should be performed in conjunction with environmental impact assessments. An up-front literature search will alert the investigator to relevant properties of the chemical under consideration and will facilitate the process of identifying the endpoints for the toxicity screens and, eventually, for the full toxicity evaluations. An adequate knowledge of the relevant toxicity endpoints will enable the researcher to make intelligent initial predictions of activity based on chemical group and structure analogies (41-43), which can save time and money in the long term. Relatively low cost experimental efforts can also be helpful in the identification of delayed safety showstoppers. A decision tree for screening chemicals based on toxicity, which encompasses the concepts from the following discussion, is presented in Figure 11.

- **Literature Search:**

The first step in assessing the toxic properties of candidate fire suppressants is to search the literature to determine what, if anything, is already known about the properties of related compounds. A useful starting place is a compendium of health and safety or toxicological data on chemicals such as Sax's *Dangerous Properties of Industrial Materials* (44). In screening for toxicity, as is also the case in environmental screening, it is important to appreciate the physical and chemical properties of the candidate because they are reliable indicators of how it will behave on and/or inside the body. This understanding can provide clues to the most important toxic endpoints. Thus, for example, if the chemical under investigation is a liquid at ambient conditions and has a pH of 2.5, the researcher should consider the possibility of skin and eye irritation.

A number of databases also exist, both computerized and non-computerized, which may be helpful when determining known toxic properties of a chemical, a set of chemicals, or even a chemical class. The following provides information on the most easily accessible or comprehensive databases available in the US.

The Chemical Abstract Services (CAS) ONLINE (<http://info.cas.org/>) database is a pay-for-services, informational compendium of thousands of substances, which includes information on chemical and physical properties, molecular formula, structure, synonyms, and in some cases, toxicity values (45).

An easily accessible online database of compiled toxicity and environmental information can be found at the free National Library of Medicine site called MEDLARS (<http://toxnet.nlm.nih.gov>). MEDLARS contains a number of specific databanks including the Registry of Toxic Effects of Chemical Substances (RTECS), Hazardous Substance Databank (HSDB), the Integrated Risk Information System (IRIS), the Genetic Toxicology (Mutagenicity) Database (GENE-TOX), and the Chemical Carcinogenesis Research Information System (CCRIS). RTECS is a comprehensive online database developed by the National Institute of Occupational Safety and Health (NIOSH) for the purpose of collecting, collating, and disseminating toxic effects information for "all known toxic substances," which are considered to be potentially all known chemicals that can elicit abnormal biological effects (45).

The Merck Index (<http://www.merck.com>) contains physical data as well as toxicity data from published literature sources. The information tabulated in the Merck Index is somewhat limited. Online versions are offered by several licensed vendors which do charge an access fee.

The Environmental Protection Agency's Office of Pollution Prevention and Toxics holds the Toxic Release Inventory (<http://www.epa.gov/opptintr/tri/>), which is a valuable free source of information about toxic chemicals that are being used, manufactured, treated, transported, or released into the environment.

For information on mutagenicity and carcinogenicity, the EPA's GENE-TOX data bank compiles genetic toxicity information on several thousand chemicals (found through the MEDLARS online site) and the International Agency for Research on Cancer (IARC) (<http://www.iarc.fr/pub/publist.htm>) publishes for-fee, monographs reviewing the carcinogenic potential of certain chemicals.

Although many of the above mentioned databases extract information from published literature, most of the information used in databases is in the form of numerical toxicity values such as LC₅₀. Literature or citation databases provide additional information which is always useful in determining the state of knowledge about chemicals under investigation. The National Library of Medicine (NLM) has a number of citation databases such as TOXLINE, MEDLINE, or CANCERLIT containing abstracted literature information on various aspects of toxicology. The NLM databases can be accessed free via the Internet (<http://igm-01.nlm.nih.gov/index.html>).

The National Technical Information Service (NTIS) covers government-sponsored research and development efforts and some work may contain toxicological information. Searches for reports can be performed free of charge, but the actual documents can only be obtained for a fee (<http://www.ntis.gov/search.htm>).

Through these resources, the initial literature search will reveal what, if any, information is known about a particular chemical or class of chemicals. From the literature search, one can usually determine the type of toxic endpoints that are associated with the chemical(s) of interest. More detailed screening procedures can then be undertaken to estimate the toxic effects of these chemicals.

- Quantitative Structure Activity Relationships:

Quantitative Structure Activity Relationships (QSARs) are helpful tools in screening chemicals. However, they are not infallible and, therefore, should not be relied on as the sole means of down selecting candidate chemicals.

QSARs can be used to estimate either specific or very general toxic endpoints. In the former case, the toxicity parameters are the endpoints of concern and are determined from the literature search, as stated above, and are usually specific to particular chemical classes. For example, looking at hydrochlorofluorocarbons (HCFCs), which have been investigated in the recent past as halon replacement agents, one would find upon performing a literature search that liver toxicity is an important concern for people exposed to this class of chemicals. Thus, when screening HCFCs, one would focus on the hepatotoxicity endpoint. Using a QSAR to estimate the liver damage potential of an HCFC would be a low cost means of determining the toxic potency of the candidate.

Some of the most important toxic endpoints to consider for some chemical classes of interest are listed Table 5. In addition, references to known QSARs that have been identified to screen for these end points are included, where available. Other QSARs can be found by searching MEDLINE using the search terms “Quantitative Structure Activity Relationships” or “QSAR” and the chemical class or specific chemical name or CAS Number. Over 125 QSARs have been developed since 1995 alone. Therefore, there is a good possibility that a validated QSAR model can be found for the chemicals of interest. A validated QSAR is a model that has been rigorously evaluated against a large set of known data points for which the QSAR is designed to predict. Accordingly, one of the starting points for QSAR development is the compilation of existing data and the determination of its dimensionality, which may be different than its ostensible size due to linear dependencies in the data. This compilation effort was covered under the previous section on Literature Search.

Table 5. Chemical Classes, Toxic Endpoints, and QSARs

Chemical Class	Functional Group	Possible Toxicity Endpoints	Reference of Possible QSARs
Alcohols	-C-OH	Irritation	46, 47, 48, 49
Aldehydes and Acetals	> C = O	Irritation, Sensitization, Anesthesia, Mutagenicity and Carcinogenicity	46, 50
Allyl compounds	H ₂ C=CH-R	Liver Toxicity, Kidney Toxicity, Neurotoxicity, Sensitization, Carcinogenicity	51
Amides	-CONH ₂	Irritation, and liver, kidney and brain toxicity	52, 53, 54, 55, 56, 57, 58, 59, 60
Amines		Cholinesterase Inhibition, Carcinogenicity	46, 61, 62, 63, 64, 65, 66, 67, 68, 69
Azides	-N ₃	Cardiovascular actions and enzyme inhibition	70
Bromides	Inorganic and organic bromides	Neurotoxicity, Irritation, Hepatotoxicity, Cardiotoxicity	71, 72, 81
Carbamates	Compounds based on NH ₂ COOH	Carcinogenicity, Mutagenicity, Teratogenicity, Cholinesterase Inhibitors	73, 74, 75, 76, 77, 78
Chlorinated Hydrocarbons	Cl-C-R	Carcinogenicity, Anesthesia, Hepatotoxicity	79, 80, 81, 82, 83, 84, 85, 86, 87
Chlorophenols	C ₆ -Cl	Carcinogenicity, Mutagenicity, Irritation, Hepatotoxicity, Cardiotoxicity	72, 88, 89, 90, 91, 92
Epoxy Compounds		Irritation, Mutagenicity, Neurotoxicity, Hepatotoxicity, Kidney Toxicity, Embryotoxicity	51, 93, 94, 95, 96, 97,
Esters	RCOOR'	Asphyxiants, Narcotics, Irritants	71, 98, 99, 100, 101, 102
Ethers	R-C-O-R'	Anesthesia, Cardiotoxicity, Irritation, Carcinogenicity	103, 72, 104, 105, 106, 107, 108
Ketones	RCOR'	Anesthesia	46, 50, 55, 101, 109, 110, 111
Nitro, Nitrate, and Nitrite	-NO _x	Irritation, Neuromuscular Dysfunction, Hepatotoxicity, Cardiotoxicity, Mutagenicity, Carcinogenicity	72, 112, 113
Nitroso compounds	C-N=O or N-N=O	Carcinogenicity, Mutagenicity, Teratogenicity	114
Organometallics	Compounds based on carbon and a metal	Irritation, Hepatotoxicity	115
Phosphorus compounds		Anesthesia, Cholinesterase Inhibition, GI Dysfunction, Irritation,	61, 98, 116, 117

Chemical Class	Functional Group	Possible Toxicity Endpoints	Reference of Possible QSARs
Sulfur Compounds		Neurotoxicity, Kidney Toxicity, Hepatotoxicity, Teratogenicity, Reproductive Toxicity Irritation, Corrosivity, Cardiotoxicity, Neurotoxicity	71, 56, 58, 72, 60

- **Laboratory Measurements:**

Two types of laboratory screening methods were identified during the workshop: limit tests and in vitro methods. An acute irritancy test, which evaluates the potential of a chemical to cause irritation in test animals after a single dose or exposure, should also be considered for solid and liquid candidates. These tests are usually performed in rabbits' eyes and skin since rabbits have a well-characterized response to irritants. Standard protocols for irritation testing are described in the EPA's Office of Prevention, Pesticides, and Toxic Substances Health Effects Test Guidelines. The guidelines for acute eye and skin irritation are 870.2400 and 870.2500, respectively (OPPTS Series 870). The URL is: http://www.epa.gov/docs/OPPTS_Harmonized/870_Health_Effects_Test_Guidelines).

Limit test methodology is well characterized and is often used as a prelude to the standardized LC₅₀ protocol (118). The typical limit test protocol calls for exposing rats to a chemical at a dose of 2 mg/L for 4 hours. However, for the application to fire suppressants, the exposure concentration would be best if it related to the fire extinguishing concentration and an exposure duration of 30 minutes or less, which is more representative of a fire fighting scenario. In addition, various routes of exposure, depending on the physical state of the chemical in question, can be specified in a limit test. For example, for gaseous agents, inhalation is likely the most important route of exposure, whereas for liquids, skin contact may be more important than inhalation.

A wide range of in vitro methods has been developed over the decades of toxicological research. Caution should always be exercised when utilizing in vitro techniques during the screening process because many factors, such as absorption and transport processes, influence the toxicity of a chemical. Thus, it may not be wise to rule out further consideration of a candidate based exclusively on the results of a single in vitro test.

In vitro methods commonly use perfused organ preparations, isolated tissue preparations, single cell suspensions, and tissue culture systems. The specific response can vary from one species to the next. Thus, depending on the endpoint, preparations should be derived from species that respond to the chemical challenge in ways which are similar to humans.

In vitro methods exist for various other endpoints, which may be useful depending on the classes of chemicals. For example, if in the literature search, it was noted that some members of the chemical class of interest elicit effects in the liver, then an in vitro method that tests the potential of a chemical to produce liver toxicity would then have a higher priority than, for example, a method to test myocardial arrhythmogenic potential.

Table 6. In Vitro methods for Specific Toxic Endpoints

Toxic Endpoint	References to In Vitro Methods
Acute Lethality	[cross reference to Vesely, D., Vesela, D., and Jelinek, R., "Nineteen Mycotoxins Tested in Chicken Embryos," <i>Toxicology Letters</i> , Vol. 13, pp. 239-245, 1982.] 119, 120, 121, 122, 123, 124, 125
Neurotoxicity	126, 127, 128, 129, 130, 131, 132, 133, 134, 135
Irritation	136, 137, 138, 139, 140, 141, 142, 143, 144, 145, 146, 147, 148, 149, 150, 151, 152, 153, 154
Anesthesia	155, 156, 157
Sensitization	158, 159, 160, 161, 162, 163, 164, 165
Kidney toxicity	166, 167, 168, 169, 170, 171, 172, 173, 174, 175
Mutagenicity	[cross reference to US Environmental Protection Agency, Short-Term Tests for Carcinogens, Mutagens, and Other Genotoxic Agents, EPA-625/9-79-003, Health Effects Research Laboratory, Research Triangle Park, NC, July 1979.] [cross reference to Hodgson, E. and Levy, P. E., "Section 8.6, In vitro and Other Short-Term Tests," <i>Modern Toxicology</i> , Elsevier Science Publishing Co., New York, 1987, p. 268.] 176, 177, 178, 179, 180, 181, 182, 183
Cholinesterase activity inhibition in nerve cells	184, 185, 186, 187, 188
Cardiotoxicity	[cross reference to Frazier, J. M., "Evaluation of In Vitro Alternatives to the Dog Sensitization Assay," ManTech Environmental Technologies, Inc., Toxic Hazards Research Unit, Dayton, Ohio, April 1994.] 189, 190, 191, 192, 193, 194, 195, 196
Hepatotoxicity	197, 198, 199, 200, 201, 202, 203
Teratogenicity	204, 205, 206, 207, 208, 209, 210, 211, 212, 213

One of the major challenges with in vitro techniques is that the mechanism of action contributing to the endpoint of interest must be understood (12). In the least, knowledge of the target organ is necessary to design a more robust in vitro assay (214). Although unspecific lethality can be investigated using in vitro methods (215), these types of screens generally have limited reliability.

Table 6 is a sample of in vitro assays that have been developed to test the endpoints delineated in Table 5. Additional in vitro methods can be found by searching MEDLINE using the search terms “in vitro” and the chemical class or specific chemical name or CAS Number.

Figure 9. Screening Protocol for Environmental Impact

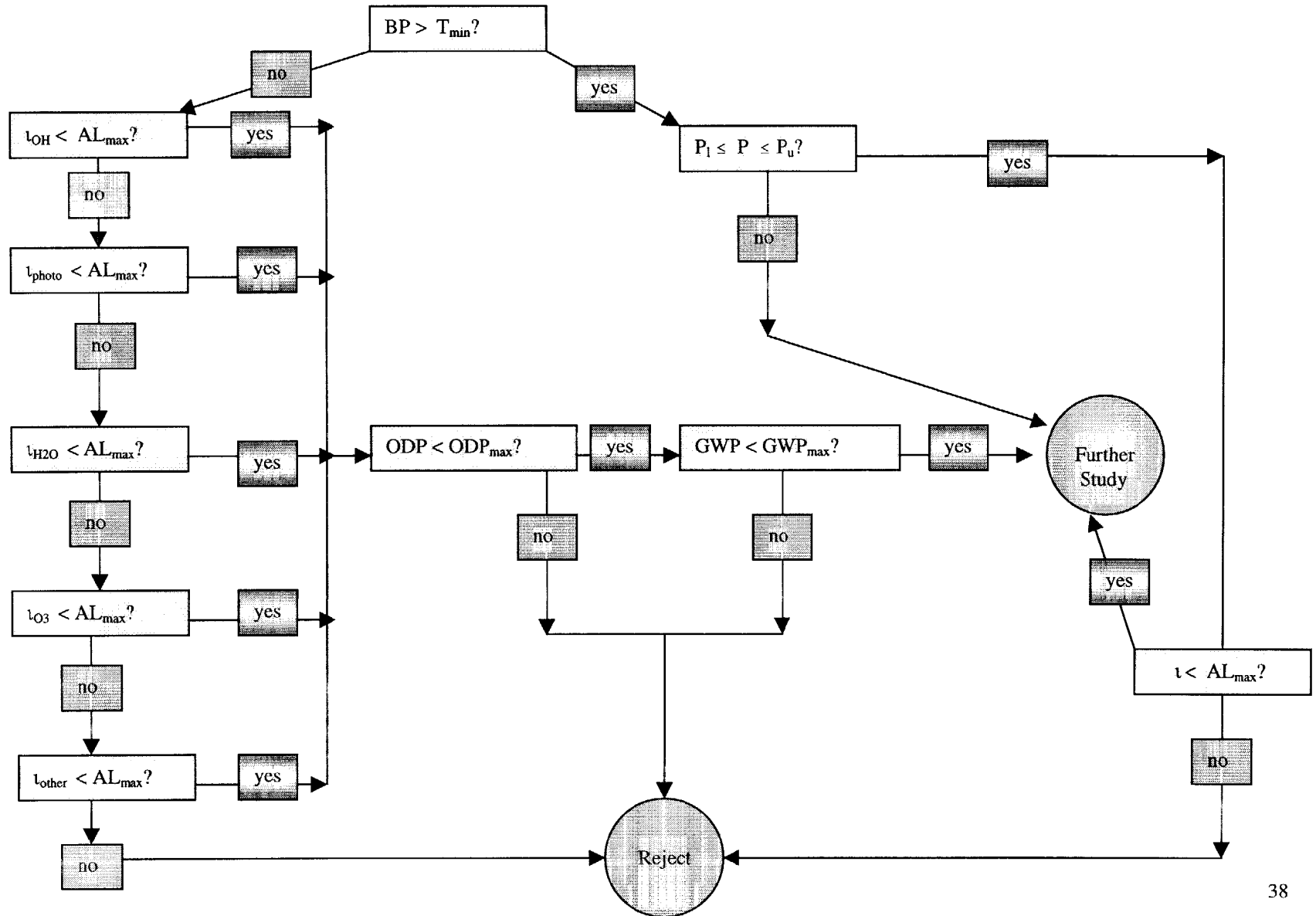

Figure 10. Screening Protocol for Materials Compatibility

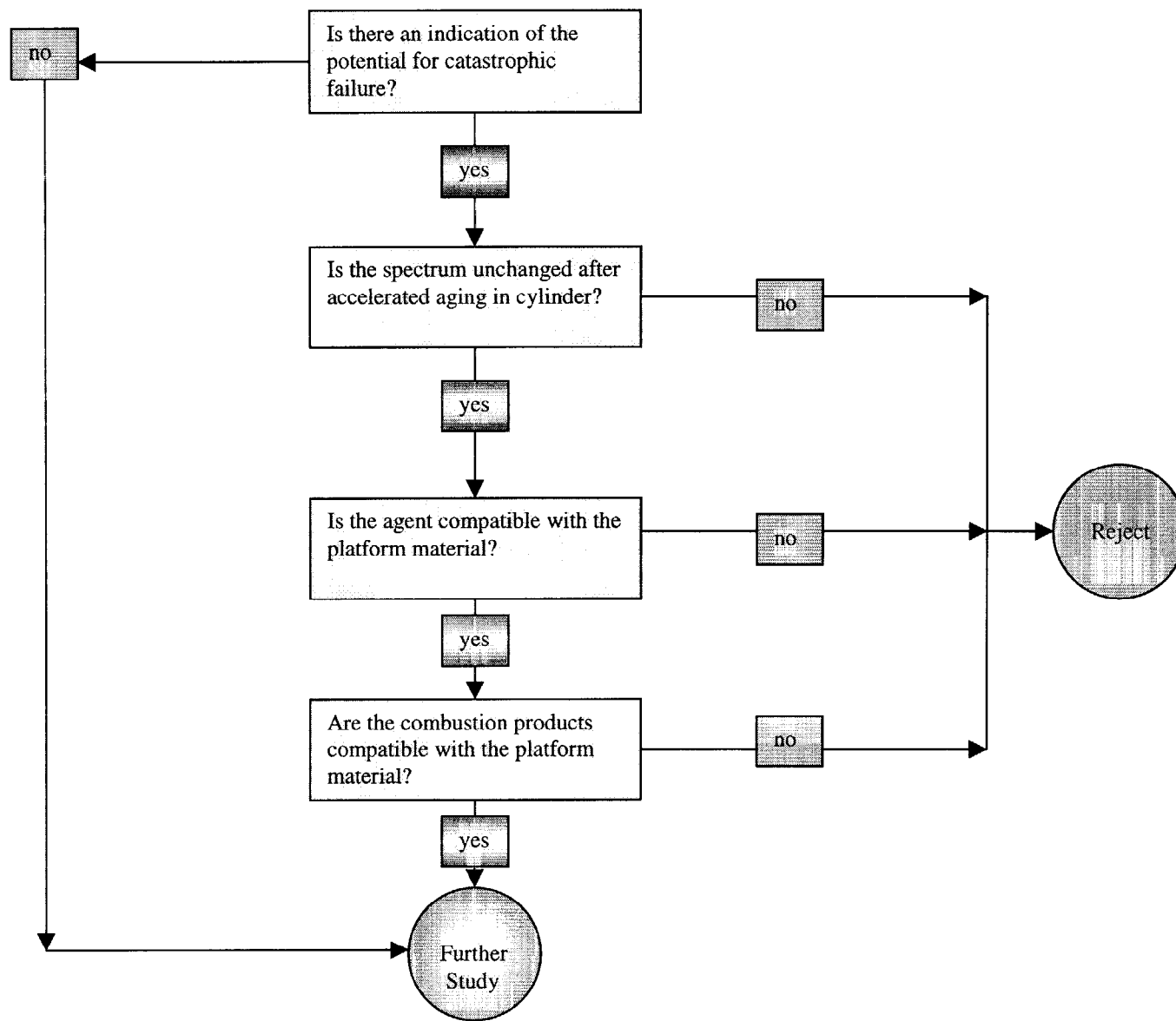
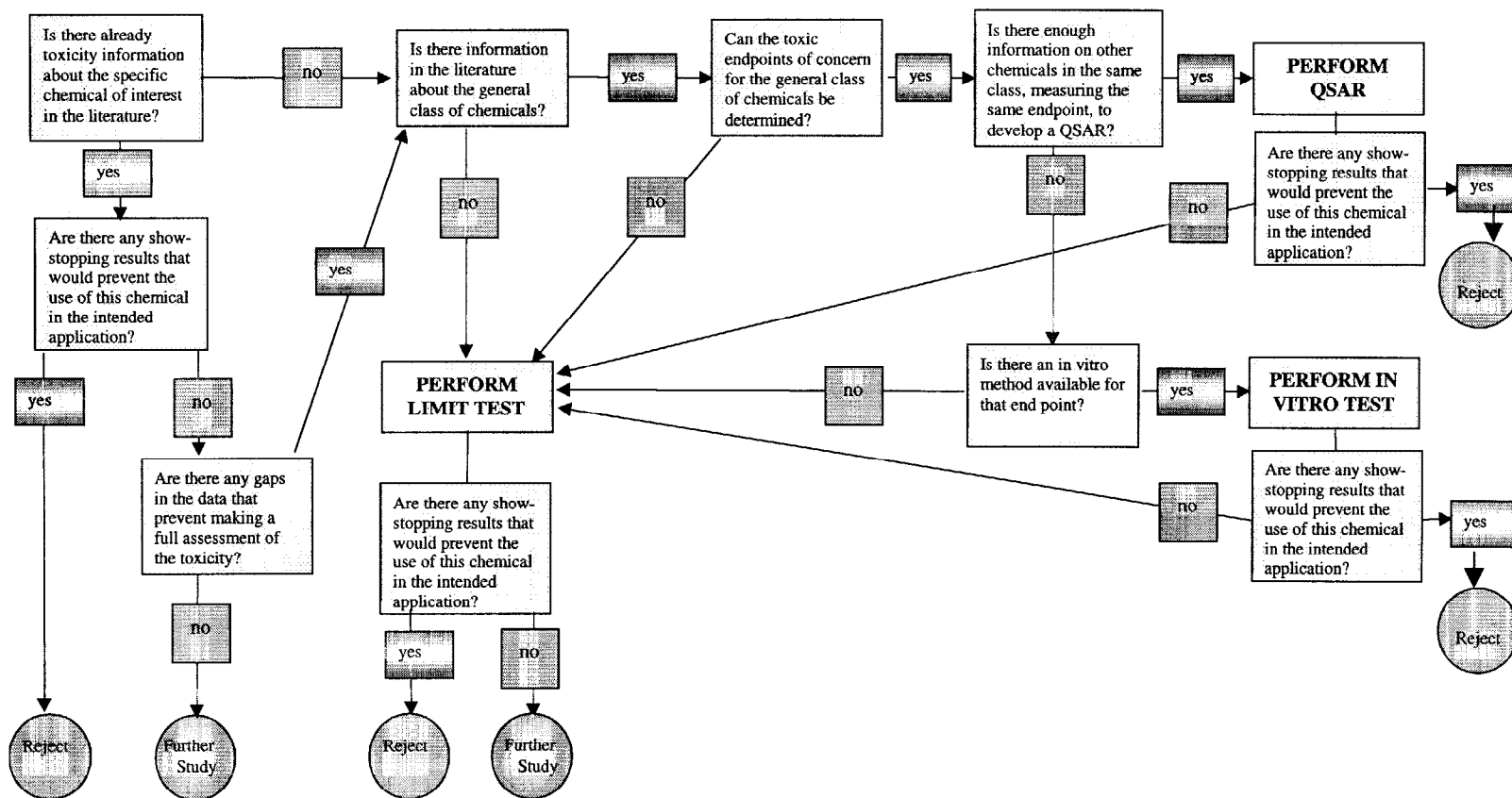

Figure 11. Decision Tree for Toxicity Screening



BLANK PAGE

Implementation of Screens

The primary motivation for performing a screen is to obtain guidance for future research efforts by providing a basis for the identification of the most promising agents from a list of candidates. The objective is to obtain a reliable indication of the likely impact/performance of the agent and chemically related compounds, rather than the value of a specific property. This task must be completed quickly, inexpensively, and frequently with limited quantities of the chemical. The consensus methods presented in this report have been formulated with these objectives in mind and should not, under any circumstances, be used to acquire data for the establishment of regulatory guidelines or for material characterizations.

The workshop participants recommended that the process of screening candidates should be implemented using a hierarchical approach beginning with a literature search of the chemical and physical properties, progressing to predictions of agent compatibility based on structure-activity relationships, and concluding with laboratory measurements and, for some properties, detailed modeling. This strategy provides the maximum degree of flexibility, since the decision to proceed to the next step in the hierarchy can be based on a consideration of the level of accuracy required for the specified application versus the time and expense involved in further testing. These considerations are critical when there are severe restrictions on the amount of time, money, and chemical that can be allocated for this purpose. The requirements to perform the full battery of tests on a candidate, for each of the consensus screens are summarized in Table 7.

Table 7. Time, Cost and Amount of Agent Required for the Consensus Screens

Screen	Elapsed Time (days)	Cost (\$)	Amount (moles)
Environmental Impact	4	10,000	0.3
Materials Compatibility	2	400	0.1
Toxicity	7	10,000	1

It is clear that fulfilling these requirements for every candidate would impose a severe hardship on NGP researchers who must satisfy their objectives with limited resources. The hierarchical implementation ensures that the full complement of tests would only be performed under exceptional circumstances, and even then, only for the most promising candidates. A road map for screening NGP candidates for their compatibility with people, materials and the environment is presented in Figure 11. The sequence begins with the environmental impact screen and ends with the screen for materials compatibility. As explained above, each screen consists of a hierarchy of steps initiated with a literature search and concluding with laboratory tests. In evaluating candidates, investigators will be expected to make a decision on whether to proceed to

the next step in the hierarchy or to terminate the process and go on to the next screen, based on the information obtained up to that point. This decision will depend on available resources. Thus, for example, if the agent is in short supply, the laboratory tests might be deferred or even eliminated entirely in favor of the literature search and QSARs, which, although less reliable, do not require any chemical.

In what follows, we illustrate the implementation of the screening process by considering two compounds, dimethyl methylphosphonate (DMMP) and *bis*-difluoromethyl ether ($\text{CHF}_2\text{OCHF}_2$, E134), that are currently under investigation by NGP researchers. The first criterion for NGP candidate screening is that the candidate should be a more effective suppressant than HFC-125. DMMP is used as a flame retardant in halogenated polyester resins and rigid polyurethane foams (216). Fisher and coworkers have demonstrated a high degree of fire suppression efficiency for this and related compounds in recent experiments sponsored by the NGP under elements 4D/3/7 and 4D/2/8 (217). Although E134 is not an effective suppressant, it belongs to a family of compounds (*i.e.*, fluorinated ethers) that have favorable environmental properties. This observation has motivated Huie and coworkers (4B/3/8) to propose brominated derivatives of these compounds as replacement candidates (218).

The screening process is initiated by performing a literature search to obtain information about the physical and chemical properties of the candidate. In reference 216, DMMP is described as a low viscosity, water-white, liquid with a boiling point of $185\text{ }^\circ\text{C}$ (the boiling point is actually $181\text{ }^\circ\text{C}$ according to 219). The relatively high boiling point of this compound suggests that the most significant environmental impact will be in the soil and ground waters, rather than the atmosphere. An octanol-water partition coefficient should be obtained for this compound, since it contains both hydrophilic ($\text{P}=\text{O}$) and hydrophobic (hydrocarbon) functionalities. As discussed in the previous section, the biggest threat to wildlife is posed by compounds which have intermediate values of this property. That is, in order to elicit a biological effect, the compound must be sufficiently hydrophobic to penetrate the cell-barrier, but not so much that it remains dissolved in the first fat layer it encounters, without ever reaching its target (22). Once the potential for biological activity is established, which is almost certainly the case for DMMP, its lifetime should be determined. Thus, it is conceivable that the environmental impact of the agent can still be low if it degrades into an innocuous form in a relatively short time. According to Weil, "the disappearance of phosphorus esters from soil and water should be favored by the natural occurrence of phosphatases in all living organisms, and by the non-enzymatic hydrolysis of organic phosphates (216)." In the case of DMMP, however, the non-enzymatic mode of removal is ineffective as the lifetime of this compound, based on the measured rate of hydrolysis at pH 7 and $25\text{ }^\circ\text{C}$, is 88 years (31). The predominant hydrolysis reaction in DMMP is the base catalyzed cleavage of the P-O bond to produce methanol and methyl methylphosphonate (the mono ester of methylphosphonic acid). It is

conceivable that this reaction might result in a loss a fire suppression efficiency and/or a corrosion problem (due to the presence of the acid) during storage.

The toxicological properties of this compound, which are reproduced to illustrate the format used in the presentation of toxicity data, are summarized in reference 44.

"DSR400	CAS:756-79-6
HR: 2	
DIMETHYL METHYLPHOSPHONATE	
mf: C ₃ H ₉ O ₃ P	mw: 124.09
PROP: Pleasant-smelling liquid. Bp: 66-68° @ 10 mm.	
SYNS: DMMP METHYLPHOSPHONIC ACID DIMETHYL ESTER NCI-C56762	
TOXICITY DATA WITH REFERENCE	
dlt-mus-ori 65 g/kg/13W-C MUREAV 138,213,84	
cyt-ham:ovr 250 mg/l NTIS** AD-A124-785	
ori-mus TDLo:33 g/kg (female 7-14D post): REP NTIS** PB85-220143	
ori-rat TDLo: 63 g/kg (63D male):REP TXAPA9 72,379,84	
ori-rat TDLo: 15,750 mg/kg (male 63D pre):REP TXAPA9 72,379,84	
ori-rat TDLo: 126 g/kg (male 63D pre):REP TXAPA9 72,379,84	
ori-rat TDLo: 515 g/kg/2Y-C:CAR FAATDF 11,91,88	
ori-rat LD50:8210 mg/kg TSCAT* FYI-OTS-0483-0242	
ivn-rat LD50:1050 mg/kg TSCAT* FYI-OTS-0483-0242	
ori-mus LD50:>6810 mg/kg NTPTR* NTP-TR-323,87	
ivn-mus LD50:912 mg/kg TSCAT* FYI-OTS-0483-0242	
CONSENSUS REPORTS: Reported in EPA TSCA Inventory.	
SAFETY PROFILE: Moderately toxic by intravenous route. Experimental reproductive effects. Questionable carcinogen with experimental carcinogenic data. Mutation data reported. An experimental nerve gas simulant. A flame retardant. When heated to decomposition it emits toxic fumes of PO _x ."	

The hazard rating (HR) of 2, which is based on an appraisal of a large number of studies, means "medium" hazard on a scale of 1, 2, or 3. Further examination of the toxicity data indicates that the acute toxicity of this compound is quite mild. Indeed, the LD₅₀ in rats from oral administration is 8210 mg/kg. This value is considerably higher than the LD₅₀ for rats given common table salt (sodium chloride), which is reported as 3,000 mg/kg in reference 220. Unfortunately, the safety profile for DMMP also points to evidence of mutagenic and/or carcinogenic activity from long-term exposures. This information warrants further consideration.

Additional information on the toxicity of DMMP was sought by searching online databases using the CAS number provided in reference 44. No references to this compound were found in the Merck index, EPA's Toxic Release Inventory, or IARC.

However, a search of the MEDLARS databank revealed a wealth of information. DMMP was listed in RTECS, CCRIS, and the HSDB.

A MEDLINE search using the chemical name "dimethyl methyl phosphate" as the SUBJECT search term was also successful in locating references to investigations of the toxicological properties of this compound. An examination of these papers revealed evidence of reproductive toxicity based on studies conducted by exposing male rats to DMMP for several weeks (221). In addition to reproductive dysfunction, DMMP also produced kidney tumors in male rats similar to those produced in animals given unleaded gasoline, hydrocarbon solvents and 1,4-dichlorobenzene (222).

The NTIS database, which was searched using the chemical name as the search term, revealed two literature references. The most significant of these was a health effects summary published by the Army Medical Research and Development Command (223). This information indicated that the acute toxicity of DMMP is relatively mild; however, effects of multiple, repeated exposures are of concern from the manufacturing and handling perspectives.

When performing a toxicity screen, it is important to pay close attention to information on structurally related compounds. This may reveal trends that apply to the compound of interest when specific information is unavailable. An understanding of the properties of related compounds can lead to insights into the nature of structural changes which might render a toxic chemical innocuous and is, therefore, highly relevant to the screening process. Several documents on other alkyl methyl phosphate chemicals were found that included references to their toxicological properties. For example, diisopropyl methylphosphonate (CAS No. 1445-75-6), which was listed in reference 44, is moderately toxic by ingestion. Information on acute lethality was also reported (224), but there was no reference to any long-term toxic effects associated with this compound. This may be an indication that the mutagenic activity of DMMP may be mitigated by structural modifications in the ester moieties. A wide range of toxicity information was also found on methyl methylphosphonate. These data are helpful in assessing the toxic nature of DMMP and facilitates an understanding of the general toxicity trends for the phosphonate class of chemicals.

Bis-difluoromethyl ether is a gaseous compound with a normal boiling point of 2 °C. Thus, the major environmental impact will be in the atmosphere. Its atmospheric lifetime is approximately 23 years (218), which is minimally less than that of HFC-125. This compound should not pose a problem with respect to storage stability and materials compatibility. This view is based on a recognition of the high degree of chemical and thermal stability associated with the C-O bond, which is the only feature that distinguishes this family of compounds (fluorinated ethers) from the hydrofluorocarbons that have already been exhaustively screened and determined to be highly compatible

with both metals and elastomers (2b-d,6a-c). Although the poor fire suppression efficiency and relatively long atmospheric lifetime of this particular compound would preclude its widespread use as a fire extinguishing agent, other fluorinated ethers have demonstrably shorter lifetimes. Indeed, the substitution of a Br for a H in E134 would be expected to result in a compound with superior environmental properties and fire suppression capability.

The toxicity screen of E134 (CAS No. 1691-17-4) was initiated by searching reference 44. Although it was not listed, references to trifluoromethyl trifluorovinyl ether (CAS No. 1187-93-5) and 1-chloro-2,2,2-trifluoroethyl difluoromethyl ether (CAS No. 26675-46-7) were available. The information on trifluoromethyl trifluorovinyl ether listed a mouse LC_{50} of $46 \mu\text{g}/\text{m}^3$ for a 2-hour inhalation exposure and the safety profile indicated that it was toxic by inhalation (225). The chlorotrifluoroethyl difluoromethyl ether is also known as isoflurane, which is used as an anesthetic (226). A number of acute toxicity data on isoflurane were provided indicating that the chemical is slightly toxic by inhalation. General information about ethers from reference 44 indicated that they generally pose acute rather than chronic hazards and are often powerful narcotics or anesthetics that in large doses can cause death (227).

The most significant toxic endpoint to consider for E134 is its anesthetic potential. A search of the NTIS database revealed that the Environmental Protection Agency, Air and Energy Engineering Research Laboratory was investigating fluorinated ethers for use in refrigerant applications (228). One reference (229) stated that "Two W. R. Grace patents (230,231) claim that E134 (bis-difluoromethyl ether) is a desirable aerosol propellant because it is non-flammable and has a low toxicity and good stability in aerosol products." Although no definitive toxicity values were presented in this study, it did contain references to a number of papers with toxicity information on other fluorinated ethers (232-236). In addition, a paper was found where a relationship between the structure and anesthetic activity of halogenated hydrocarbons (237) was examined. This study provides a basis for the development QSARs for the anesthetic activity of fluorinated ethers, which could then be used as the point of departure for a more detailed evaluation and analysis of this compound. This might include a laboratory screening method, based on a modified whole animal limit test, to determine the anesthetic and lethal concentrations of E134. In this application, the traditional limit test protocol would have to be modified to reflect the exposure time (10-30 minutes) and concentrations (in the vicinity of the flame extinguishing concentration) typical of a fire scenario.

The results of our preliminary screen indicate that E134 is not a promising candidate, since it does not appear to offer any advantages over HFC-125. With regards to DMMP, there are some long-term toxicity and environmental issues that must be addressed before it can be recommended for widespread use as a fire suppressant. Our assessment of DMMP is tentative in nature because of the absence of any measurements

of the octanol-water partition coefficient. Once this data is obtained, the QSAR analysis will provide the guidance needed for a more definitive recommendation. In this context, it should be stated that the rejection of a specific compound does not necessarily mean that research on the mechanisms of action and properties should be discontinued. This decision may involve factors beyond the scope of the screening procedure. Indeed, we suspect that the long-term toxicity issues, associated with DMMP, and the environmental impact and performance problems of TFME, can be remedied by simple structural modifications of these compounds.

Figure 12. Decision Tree for Screening NGP Candidates

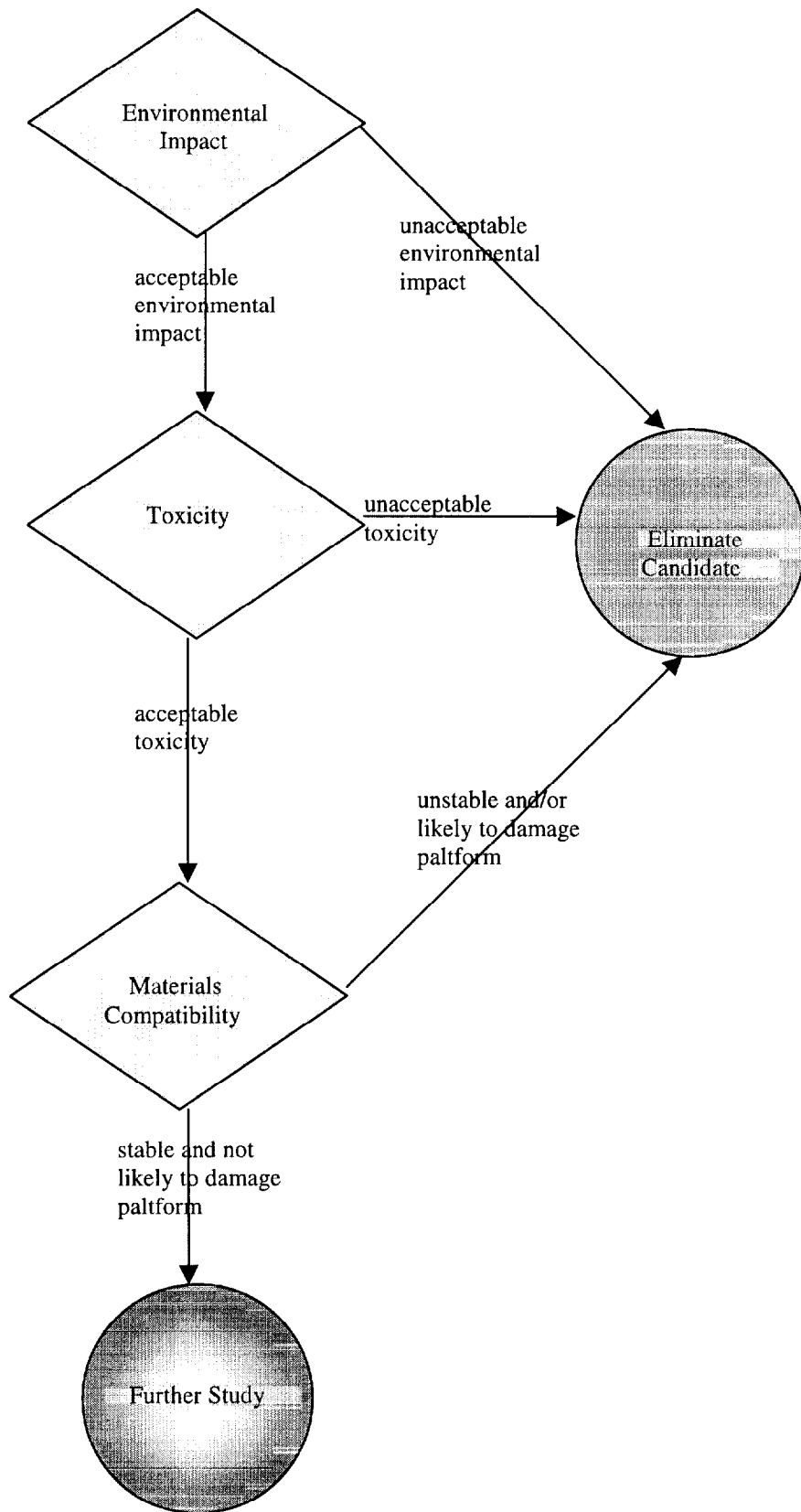

Summary and Conclusions

Researchers working on NGP projects are proposing new chemical agents; and technically sound, consensus methods are needed to determine whether to pursue each of these candidates further. A workshop was held on November 14 and 15, 1997 at NIST in response to this need. In attendance were approximately 40 representatives from government, academia, and industry who participated in the evaluation and revision of test methods for assessing the compatibility of chemical candidates for the next generation of fire suppressants with people, materials, and the environment. The focus of the workshop was on screening tests, which are meant to assist in the down selection process, as opposed to evaluation/analysis tests, which are meant to provide a complete evaluation of chemical properties for input into the risk assessment process. For each property, the workshop participants compared currently used measurement methods and identified the best method for future use. Each of these "best current" methods was evaluated and given one the following designations: acceptable as is, acceptable with modifications, or unacceptable.

Although the participants agreed that the existing methodologies did comprise a sound basis for candidate screening, they also recognized that the search for next generation fire suppressants will encompass a much wider range of compounds than have been considered in previous efforts, which have focussed almost exclusively on halogen-containing compounds. Consequently, it was felt that the methods used to screen these candidates must be flexible enough to accommodate a much more diverse set of physical, chemical, and toxicological properties and that a predetermined set of standardized procedures would not be adequate. Instead, the participants recommended using a hierarchical approach beginning with a literature search of the relevant chemical and physical properties, progressing to structure-activity based predictions of agent compatibility, and culminating in laboratory measurements and detailed modeling, when more reliable assessments are required. This strategy provides the desired level of flexibility, since the decision to proceed to the next step in the hierarchy can be based on a consideration of the level of accuracy required for the specified application versus the time and expense involved in further testing. It also facilitates the process of screening a large number of candidates when there are severe restrictions on the amount of time, money, and chemical that can be allocated for this purpose.

At the conclusion of the workshop, a consensus method was advanced for each property. The recommended screens for environmental impact, materials compatibility and toxicity are summarized in Figures 8, 9 and 10, respectively. Since these methods are based on existing technologies, no new research programs are required for their implementation. The emphasis on using structure-activity relationships to supplement laboratory measurements in making assessments on individual candidates, however,

presumes that resources will be available to develop the prerequisite databases for promising families of chemicals.

1. Gann, R.G., Barnes, J.D., Davis, S., Harris, J.S., Harris, R.H., Herron, J.T., Levin, B.C., Mopsik, F.I., Notarianni, K.A., Nyden, M.R., Paabo, M., and Ricker, R.E., *Preliminary Screening Procedures and Criteria for Replacements for Halons 1211 and 1301*, NIST Tech Note **1278**, National Institute of Standards and Technology, 1990, 305 pages.

- a. Nyden, Marc R., "Stability Under Long-Term Storage."
- b. Herron, John T., "Ozone Depletion Potential."
- c. Herron, John T., "Global Warming Potential."
- d. Ricker, Richard E., Harris, Jonice, "Metals Corrosion."

2. Grosshandler, W.L., Pitts, W.M., and Gann, R.G., eds., *Evaluation of Alternative In-Flight Fire Suppressants for Full-Scale Testing in Simulated Aircraft Engine Nacelles and Dry Bays*, NIST Special Publication **861**, April, 1994, 844 pages. See especially the following chapters:

- a. Nyden, Marc R., Linteris, Gregory T., Burgess, Jr., Donald R.F., Westmoreland, Philip R., Tsang, Wing and Zachariah, Michael R., "Flame Inhibition Chemistry and the Search for Additional Fire Fighting Chemicals."
- b. Peacock, Richard D., Cleary, Thomas G., and Harris Jr., Richard H., "Agent Stability Under Storage and Discharge Residue."
- c. Ricker, Richard E., Stoudt, Mark R., Dante, James F., Fink, James L., Beauchamp, Carlos R., and Moffit, Thomas P., "Corrosion of Metals."
- d. McKenna, Gregory B., Waldron Jr., William K., and Horkay, Ferenc, "Elastomer Seal Compatibility."
- e. Braun, Emil, Peacock, Richard D., Forney, Glenn P., Mulholland, George W., and Levin, Barbara C., "Human Exposure and Environmental Impact."

3. Gann, R.G., Beauchamp, C.R., Cleary, T.G., Fink, J.L., Harris, R.H., Horkay, F., McKenna, G.B., Moffat, T.P., Nyden, M.R., Peacock, R.D., Ricker, R.E., Stoudt, M.R., and Waldron, W.K., "Compatibility of Halon Alternatives During Storage," in *Halon Replacements: Technology and Science*, ACS Symposium Series **611**, American Chemical Society, Washington, D.C. (1995), 17 pages.

4. *Scientific Assessment of Stratospheric Ozone*, Global Ozone Research and Monitoring Project - Report No. 20, World Meteorological Organization (1989).

5. Significant New Alternative Policy (SNAP) Program Final Rule, Federal Register, Vol. **59**, pg 13044, March 18, 1994.

6. Gann, R.G., ed., *Fire Suppression System Performance of Alternative Agents in Aircraft Engine and Dry Bay Laboratory Simulations*, NIST Special Publication SP 890 (two volumes), 1995, 1411 pages.

a. Stoudt, Mark R., Fink, James L., Dante, James F., Ricker, "Compatibility with Metals."

b. McKenna, Gregory B., Horkay, Ferenc, Verdier, Peter, H., and Waldron Jr., William K., "Interactions of Agents with Elastomers."

c. Harris Jr., Richard H., "Agent Stability Under Storage."

7. Martin, Yvonne C., "Studies of Relationships between Structural Properties and Biological Activity by Hansch Analysis," in Golberg, Leon, editor, *Structure-Activity Correlation as a Predictive Tool in Toxicology*, Hemisphere Publishing, Washington, DC, 1983, pg. 77

8. Golberg, Leon, editor, *Structure-Activity Correlation as a Predictive Tool in Toxicology*, Hemisphere Publishing, Washington, DC, 1983.

9. Chan, P. and Hayes, A. W., "Acute Toxicity and Eye Irritancy," in Hayes, Wallace A., editor, *Principles and Methods of Toxicology*, Third Edition, Raven Press, Ltd., New York, 1994.

10. Grzyll, L. R. and Back, D. D., "Development of Quantitative Structure-Property Relationships for Tropodegradable Halocarbon Fire Suppression Agents," Final Report, prepared for Applied Research Associates, March 1997.

11. Grzyll, L. R., Back, D. D., Ramos, C., and Samad, N. A., "Screening and Characterization of Second-Generation Halon Replacements," Proceedings of the 1995 Halon Options Technical Working Conference, Albuquerque, NM, May 1995.

12. Skaggs, S. R., Tapscott, R. E., and Heinonen, E. W., *Toxicological Screening Methods*, NMERI 95/48/31882, prepared for Wright Laboratories (WL/FIVCF), Tyndall Air Force Base, FL, December 1996.

13. Organization of Economic and Commercial Development (OECD), "Acute Inhalation Toxicity," Guideline 403, Adopted 12 May 1981, Paris, France.

14. Tinker, John F., "Relating Bacterial Mutagenesis Activity To Chemicals Structure," in Golberg, Leon, editor, *Structure-Activity Correlation as a Predictive Tool in Toxicology*, Hemisphere Publishing, Washington, DC, 1983, pg. 207.

15. US Environmental Protection Agency, *Short-Term Tests for Carcinogens, Mutagens, and Other Genotoxic Agents*, EPA-625/9-79-003, Health Effects Research Laboratory, Research Triangle Park, NC, July 1979.

16. Hodgson, E. and Levy, P. E., "Section 8.6, In vitro and Other Short-Term Tests," *Modern Toxicology*, Elsevier Science Publishing Co., New York, 1987, p. 268.

17. Chung K.T.; Purcell W.P.; Kirkovsky A.; Kirkovsky L. "Review of mutagenicity of monocyclic aromatic amines: quantitative structure-activity relationships. *Mol Pharmacol* 1997 Aug;52(2):323-34.

-
18. So S.S.; Karplus M., "Three-dimensional quantitative structure-activity relationships from molecular similarity matrices and genetic neural networks. 2. Applications." *J Med Chem* 1997 Dec 19;40(26):4360-71.
 19. Frazier, J. M., Evaluation of In Vitro Alternatives to the Dog Sensitization Assay, ManTech Environmental Technologies, Inc., Toxic Hazards Research Unit, Dayton, Ohio, April 1994.
 20. McCall, D., "Effects of Quinidine and Temperature on Sodium Uptake and Contraction Frequency of Cultured Rat Myocardial Cells," *Circulation Research*, Vol. 39, pp. 730-735, 1976.
 21. ASTM, Designation E 1147 – 92, "Standard Test Method for Partition Coefficient (N-Octanol/Water) Estimation by Liquid Chromatography," *Annual Book of ASTM Standards*, **11.05**, 1998, pp. 420-423.
 22. Hansch, C., "A Quantitative Approach to Biochemical Structure-Activity Relationships," *Acc. Chem. Res.* **2**, 1969, pp. 232-239.
 23. Clements, Richard, G., Editor, *Estimating Toxicity of Industrial Chemicals to Aquatic Organisms Using Structure Activity Relationships. Volume I*, US Environmental Protection Agency, EPA-560-6-88-001, July 88.
 - 24 Documentation: The ECOSAR User Manual, ECOSAR: A Computer Program for Estimating the Ecotoxicity of Industrial Chemicals (EPA-748-R-93-002), and Estimating Toxicity of Industrial Chemicals to Aquatic Organisms Using Structure Activity Relationships (EPA-748-R-93-001)
 - 25 Russom, C.L., S.P. Bradbury, S.J. Broderius, D.E. Hammermeister and R.A. Drummond. "Predicting modes of action from chemical structure: Acute toxicity in the fathead minnow (*Pimephales promelas*)" *Environmental Toxicology and Chemistry* 1997. 16(5): 948-967.
 26. Fischer, D.A., Hales, C.H, Filkin, D.L., Ko, M.K.W. Sze, N.D., Connel, P.S., Wuebbles, D.J., Isaksen, I.S.A., and Stordal, F., "Relative Effects on Stratospheric Ozone of Halogenated Methanes and Ethanes of Social and Industrial Interest," in World Meteorological Organization, Global Ozone Research and Monitoring Project – Report 20, *Scientific Assessment of Stratospheric Ozone 1989*, Vol. II, pp. 301-377.
 27. Tapscott, R.E. and Olivares-Sooley, M.G., "A Decision Tree for Global Environmental Technologies," Halon Options Technical Working Conference, Albuquerque, NM, 1998.
 28. Nimitz, J.S. and Skaggs, S.R., "Estimating Tropospheric Lifetimes and Ozone-Depletion Potentials of One- and Two-Carbon Hydrofluorocarbons, *Environ. Sci. Technol.* **26**, 1992, pp. 739-744.
 29. Nyden, Marc R., "The Molecular Level Design of Fire Retardants and Suppressants," NISTIR **6275**, United States Department of Commerce, 1999, 33 pages.
 30. Calvert, J.G. and Pitts, J.N., *Photochemistry*, Wiley and Sons, New York, 1966.
 31. Mabey, W. and Mill, T., "Critical Review of Hydrolysis of Organic Compounds in Water Under Environmental Conditions," *J. Phys. Chem. Ref. Data* **7**, 1978, pp. 383-415.

-
32. March, J., "Advanced Organic Chemistry: Reactions, Mechanisms, and Structure," McGraw-Hill, New York, 1968, pp 871-875.
 33. Fischer, D.A., Hales, C.H, Wang, W-C., Ko, M.K.W. and Sze, N.D., "Relative Effects on Global Warming of Halogenated Methanes and Ethanes of Social and Industrial Interest," in World Meteorological Organization, Global Ozone Research and Monitoring Project – Report 20, Scientific Assessment of Stratospheric Ozone 1989, Vol. II, pp. 383-401.
 34. Silverstein, R.M, Bassler, G.C., and Morrill, T.C., "Spectrometric Identification of Organic Compounds (third edition)," John Wiley & Sons, Inc., New York, 1974, pp 73-157.
 35. Bicerano, Jozef, "Prediction of Polymer Properties (second edition)," Marcel Dekker, New York, 1996.
 36. Ricker, R.E., personal communication.
 37. ASTM, Designation F 945 – 85, "Standard Test Method for Stress-Corrosion of Titanium Alloys with Aircraft Engine Cleaning Materials," Annual Book of ASTM Standards, **15.03**, 1997, pp 807-810.
 38. Stoudt, M.R., Fink, J.L. and Ricker, R.E., "Evaluation of the Propensity of Replacements for Halon 1301 to Induce Stress-Corrosion Cracking in Alloys Used in Aircraft Fire-Suppressant Storage and Distribution Systems," Journ. Mater. Engin. and Perform. **5**, 1996, 507.
 39. Flory, P.J., "Thermodynamics of High Polymer Solutions," J. Chem. Phys. **10**, 1942.
 40. Huggins, M.L., "Some Properties of Solutions of Long-Chained Compounds," J. Phys. Chem. **46**, 1942, 151.
 41. Dunn, William J. and Wold, Svante, "The Use of SIMCA Pattern Recognition in Predicting the Carcinogenicity of Potential Environmental Pollutants," in Golberg, Leon, editor, *Structure-Activity Correlation as a Predictive Tool in Toxicology*, Hemisphere Publishing, Washington, DC, 1983, pp. 141.
 42. Clayton, J. Wesley, Jr. "The Toxicity of Fluorocarbons with Special Reference to Chemical Constitution," Journal of Occupational Medicine, Vol. 4, No. 5, May 1962, P 262.
 43. Hodge, Harold C., Smith, Frank A., and Chen, Philip S., "Structure-Toxicity Relations," in Simons, J. H., Editor, Fluorine Chemistry, *Volume III, Biological Effects of Organic Fluorides*, Academic Press, New York, 1963, Pg. 25.
 44. Lewis, R. J., Sr., *Sax's Dangerous Properties of Industrial Materials*, Ninth Edition, Van Nostrand Reinhold, New York, 1996.
 45. Akland, Ann H. and Waters, Michael D., "Chemical and Toxicological Data Bases for Assessment of Structure-Activity Relationships," in Golberg, Leon, editor, *Structure-Activity Correlation as a Predictive Tool in Toxicology*, Hemisphere Publishing, Washington, DC, 1983, pg. 23.
 46. Alarie Y; Abraham MH; Nielsen GD; Schaper M. "Structure-activity relationships of volatile organic chemicals as sensory irritants," Arch Toxicol 1998 Feb;72(3):125-40.

-
47. Wang, G., Bai, N., "Structure-activity relationships for rat and mouse LD50 of miscellaneous alcohols," *Chemosphere* 1998 Mar;36(7):1475-83.
 48. Rucki, M., Tichy, M., "Acute toxicity of alcohols: prediction by QSAR analysis and by molecular similarity," *Cent Eur J Public Health* 1997 Dec;5(4):183-7.
 49. Debord J, et al. "Inhibition of arylesterase by aliphatic alcohols," *Chem Biol Interact.* 1998 May 15;113(2):105-15.
 50. Cronin, M. T., Schultz, T.W., "Structure-toxicity relationships for three mechanisms of action of toxicity to *Vibrio fischeri*." *Ecotoxicol Environ Saf* 1998 Jan;39(1):65-9.
 51. Politzer P, et al. "Molecular properties of the chlorinated ethylenes and their epoxide metabolites," *Ann N Y Acad Sci.* 1981;367:478-92.
 52. Boyes, R. N., "A review of the metabolism of amide local anaesthetic agents." *Br J Anaesth* 1975 Feb;47 suppl:225-30.
 53. Huang Y., et al., "Synthesis and quantitative structure-activity relationships of N-(1-benzylpiperidin-4-yl) phenylacetamides and related analogues as potent and selective sigma1 receptor ligands," *J. Med. Chem.* 1998 Jun 18;41(13):2361-70.
 54. Hadjipavlou-Litina D, "Review, reevaluation, and new results in quantitative structure-activity studies of anticonvulsants," *Med Res Rev.* 1998 Mar;18(2):91-119.
 55. Nilsson J., et al. "GRID/GOLPE 3D quantitative structure-activity relationship study on a set of benzamides and naphthamides, with affinity for the dopamine D3 receptor subtype," *J. Med. Chem.* 1997 Mar 14;40(6):833-40.
 56. Krystek S.R. Jr., et al, "Three-dimensional quantitative structure-activity relationships of sulfonamide endothelin inhibitors," *J. Med. Chem.* 1995 Feb 17;38(4):659-68.
 57. Mager P.P. "QSAR, diagnostic statistics, and molecular modelling of antiallergic acrylamide derivatives," *Drug Des Discov.* 1992;9(2):107-18.
 58. Kaul S., et al. "Quantitative structure--pharmacokinetic relationship of a series of sulfonamides in the rat," *Eur. J. Drug Metab. Pharmacokinet.* 1990 Jul-Sep;15(3):211-7.
 59. Lisciani R, et al. "Structure-analgesic activity relationships in a set of 2-aminobenzamide derivatives," *Farmaco [Sci].* 1986 Feb;41(2):89-102.
 60. Seydel J.K., et al. "Quantitative structure-pharmacokinetic relationships derived on antibacterial sulfonamides in rats and its comparison to quantitative structure-activity relationships," *J. Med. Chem.* 1980 Jun;23(6):607-13.
 61. Recanatini, M., Hansch, C., and Cavalli, A., "A comparative QSAR analysis of acetylcholinesterase inhibitors currently studied for the treatment of Alzheimer's disease," *Chem. Biol. Interact.* 1997 Aug 1;105(3):199-228
 62. Chung, K. T., Purcell, W.P., Kirkovsky, A., Kirkovsky, L., "Review of mutagenicity of monocyclic aromatic amines: quantitative structure-activity relationships,"
 63. Debord J., et al. "Cholinesterase inhibition by derivatives of 2-amino-4,6-dimethylpyridine," *J. Enzyme Inhib.* 1997 Apr;12(1):13-26.

-
64. Akamatsu M., et al. "Quantitative analyses of the structure-hydrophobicity relationship for N-acetyl di- and tripeptide amides," *J. Pharm. Sci.* 1994 Jul;83(7):1026-33.
65. McGuire E.J., et al. "Peroxisome induction potential and lipid-regulating activity in rats. Quantitative microscopy and chemical structure-activity relationships," *Am J Pathol.* 1991 Jul;139(1):217-29.
66. Dai Q.H., et al. "Quantitative explanation on structure-carcinogenic activity relationship of aromatic amines by di-region theory," *SCI CHINA B.* 1991 May;34(5):547-59.
67. Trieff N.M., et al. "Aromatic amines and acetamides in *Salmonella typhimurium* TA98 and TA100: a quantitative structure-activity relation study," *Mol Toxicol.* 1989 Winter;2(1):53-65.
68. Purdy R., "The utility of computed superdelocalizability for predicting the LC50 values of epoxides to guppies," *Sci Total Environ.* 1991 Dec;109-110:553-6.
69. Hatch F.T., et al. "Quantitative structure-activity (QSAR) relationships of mutagenic aromatic and heterocyclic amines," *Mutat. Res.* 1997 May 12;376(1-2):87-96.
70. Sabbioni G., et al. "Quantitative structure-activity relationships of mutagenic aromatic and heteroaromatic azides and amines," *Carcinogenesis.* 1992 Apr;13(4):709-13.
71. Roberts, D. W., Basketter, D. A., "Further evaluation of the quantitative structure-activity relationship for skin-sensitizing alkyl transfer agents," *Contact Dermatitis* 1997 Sep;37(3):107-12.
72. Ehring G.R., et al. "Quantitative structure activity studies of antiarrhythmic properties in a series of lidocaine and procainamide derivatives," *J. Pharmacol. Exp. Ther.* 1988 Feb;244(2):479-92.
73. Romoff T.T., et al. "Urethane-protected N-carboxyanhydrides (UNCAs) as unique reactants for the study of intrinsic racemization tendencies in peptide synthesis," *J. Pept. Res.* 1997 Apr;49(4):281-92.
74. Horwell D.C., et al. "Quantitative structure-activity relationships (QSARs) of N-terminus fragments of NK1 tachykinin antagonists: a comparison of classical QSARs and three-dimensional QSARs from similarity matrices," *J. Med. Chem.* 1995 Oct 27;38(22):4454-62.
75. Bachrata M., et al., "Study of local anaesthetics. Part 93: A contribution to the study of OSAR in the group of derivatives of phenylcarbamic acid," *Pharmazie.* 1989 Jan;44(1):25-8.
76. Tanaka M., et al., "Quantitative structure-activity relationships of anticonvulsant aralkyl and alkyl carbamates," *Chem Pharm Bull (Tokyo).* 1985 Jun;33(6):2403-10.
77. Yamagami C., et al., "A quantitative structure-activity study of anticonvulsant benzyl N,N-dimethylcarbamates," *Chem Pharm Bull (Tokyo).* 1982 Nov;30(11):4175-80.

-
78. Goldblum A, et al., "Quantitative structure-activity relationship of phenyl N-methylcarbamate inhibition of acetylcholinesterase," *J Agric Food Chem.* 1981 Mar-Apr;29(2):277-88.
79. Chaisuksant Y., et al., "Effects of halobenzenes on growth rate of fish (*Gambusia affinis*)," *Ecotoxicol. Environ. Saf.* 1998 Feb;39(2):120-30.
80. Waller C.L., et al. "Modeling the cytochrome P450-mediated metabolism of chlorinated volatile organic compounds," *Drug Metab Dispos.* 1996 Feb;24(2):203-10.
81. Roldan-Arjona T., et al. Mutagenic and lethal effects of halogenated methanes in the Ara test of *Salmonella typhimurium*: quantitative relationship with chemical reactivity. *Mutagenesis.* 1993 Mar;8(2):127-31.
82. Mumtaz M.M., et al. "A weight-of-evidence approach for assessing interactions in chemical mixtures," *Toxicol Ind Health.* 1992 Nov-Dec;8(6):377-406.
83. Crebelli R., et al., The induction of mitotic chromosome malsegregation in *Aspergillus nidulans*. Quantitative structure activity relationship (OSAR) analysis with chlorinated aliphatic hydrocarbons," *Mutat. Res.* 1992 Apr;266(2):117-34.
84. Benigni R., et al., Relationship between chlorofluorocarbon chemical structure and their *Salmonella* mutagenicity," *J. Toxicol. Environ Health.* 1991 Nov;34(3):397-407.
85. Devillers J., et al. "[Quantitative structure-activity relations of the lethal effects of 38 halogenated compounds against *Lepomis macrochirus*]," *C. R. Acad. Sci. III.* 1986;303(14):613-6. French.
86. Weinstein H., et al., "Determinants of molecular reactivity as criteria for predicting toxicity: problems and approaches," *Environ. Health Perspect.* 1985 Sep;61:147-62.
87. Sabljic A., "Quantitative structure-toxicity relationship of chlorinated compounds: a molecular connectivity investigation," *Bull Environ Contam. Toxicol.* 1983 Jan;30(1):80-3.
88. Mekenyan O.G., et al. "A QSAR evaluation of Ah receptor binding of halogenated aromatic xenobiotics," *Environ. Health Perspect.* 1996 Dec;104(12):1302-10.
89. Safe S.H., "Polychlorinated biphenyls (PCBs): environmental impact, biochemical and toxic responses, and implications for risk assessment," *Crit. Rev. Toxicol.* 1994;24(2):87-149.
90. Krishnan V., et al., "Polychlorinated biphenyls (PCBs), dibenzo-p-dioxins (PCDDs), and dibenzofurans (PCDFs) as antiestrogens in MCF-7 human breast cancer cells: quantitative structure-activity relationships," *Toxicol. Appl. Pharmacol.* 1993 May;120(1):55-61.
91. Mason G., et al. "Polychlorinated dibenzofurans (PCDFs): correlation between in vivo and in vitro structure-activity relationships," *Toxicology.* 1985 Oct;37(1-2):1-12.
92. Safe S., et al. "PCBs: structure-function relationships and mechanism of action," *Environ Health Perspect.* 1985 May;60:47-56.
93. Politzer P., Trefonas, P., 3d, Politzer, I.R., Elfman, B., "Molecular properties of the chlorinated ethylenes and their epoxide metabolites," *Ann. N Y Acad. Sci.*, 1981, 367: 478-92.

-
94. Politzer P., et al., Molecular properties of the chlorinated ethylenes and their epoxide metabolites," *Ann. N Y Acad. Sci.* 1981;367:478-92
 95. Hooberman BH, et al., "Quantitative structure-activity relationships for the mutagenicity of propylene oxides with Salmonella," *Mutat Res.* 1993 Apr;299(2):85-93.
 96. Purdy R., "The utility of computed superdelocalizability for predicting the LC50 values of epoxides to guppies," *Sci. Total Environ.* 1991 Dec;109-110:553-6.
 97. Lutz W.K., "Structural characteristics of compounds that can be activated to chemically reactive metabolites: use for a prediction of a carcinogenic potential," *Arch Toxicol Suppl.* 1984;7:194-207.
 98. Johnson M.K. "The mechanism of delayed neuropathy caused by some organophosphorus esters: using the understanding to improve safety," *J Environ Sci Health [B].* 1980;15(6):823-41.
 99. Xu R., et al., "Synthesis, antimuscarinic activity and quantitative structure-activity relationship (QSAR) of tropinyl and piperidinyl esters," *Chem. Pharm. Bull. (Tokyo).* 1998 Feb;46(2):231-41.
 100. Jones S.L., et al., "Quantitative structure-activity relationships for estimating the no-observable-effects concentration in fathead minnows (*Pimephales promelas*)," *Qual. Assur.* 1995 Sep;4(3):187-203.
 101. Jaworska J.S., et al., "Quantitative structure-toxicity relationships and volume fraction analyses for selected esters," *Arch. Environ. Contam. Toxicol.* 1995 Jul;29(1):86-93.
 102. Kluwe W.M., "Carcinogenic potential of phthalic acid esters and related compounds: structure-activity relationships," *Environ. Health Perspect.* 1986 Mar;65:271-8.
 103. Nielsen, G. D., et al., "Sensory irritation mechanisms investigated from model compounds: trifluoroethanol, hexafluoroisopropanol and methyl hexafluoroisopropyl ether," *Arch. Toxicol.* 1996;70(6):319-28.
 104. Lukoianov N.V., et al., "[Quantitative dependence of structure-antiseizure activity in a series of macrocyclic compounds]," *Vopr. Med. Khim.* 1998 Mar-Apr;44(2):185-93. Russian.
 105. Ren S., et al., "QSAR analysis of membrane permeability to organic compounds," *J Drug Target.* 1996;4(2):103-7.
 106. Hamerton I., et al., "Development of quantitative structure property relationships for poly(arylene ethers)," *J. Mol. Graph.* 1995 Feb;13(1):14-7, 51.
 107. Hooberman B.H., et al., "Quantitative structure-activity relationships for the mutagenicity of propylene oxides with Salmonella," *Mutat. Res.* 1993 Apr;299(2):85-93.
 108. Di Paolo T., "Structure--activity relationships of anesthetic ethers using molecular connectivity," *J. Pharm. Sci.* 1978 Apr;67(4):564-6.
 109. Di Paolo T., "Molecular connectivity in quantitative structure--activity relationship study of anesthetic and toxic activity of aliphatic hydrocarbons, ethers, and ketones," *J Pharm. Sci.* 1978 Apr;67(4):566-8.

-
110. Cronin M.T., et al., "Structure-toxicity relationships for three mechanisms of action of toxicity to *Vibrio fischeri*," *Ecotoxicol. Environ. Saf.* 1998 Jan;39(1):65-9.
111. Wieland T., "The use of structure generators in predictive pharmacology and toxicology," *Arzneimittelforschung.* 1996 Feb;46(2):223-7.
112. Dai Q.H., et al., "Quantitative pattern recognition for structure-carcinogenic activity relationship of N-nitroso compounds based upon Di-region theory," *Sci. China [B].* 1989 Jul;32(7):776-90.
113. Purdy R., "A mechanism-mediated model for carcinogenicity: model content and prediction of the outcome of rodent carcinogenicity bioassays currently being conducted on 25 organic chemicals," *Environ. Health Perspect.* 1996 Oct;104 Suppl 5:1085-94.
114. Lewis, D.F., Parke, D.V., Walker, R., "Ioannides C., Brantom PG Nitrosamine carcinogenesis: rodent assays, quantitative structure-activity relationships, and human risk assessment," *Drug Metab. Rev.* 1997 Nov;29(4):1055-78.
115. Prestrelski S.J., et al. "Effect of metal ion binding on the secondary structure of bovine alpha-lactalbumin as examined by infrared spectroscopy," *Biochemistry.* 1991 Sep 10;30(36):8797-804.
116. So, S. S., Karplus, M., "Three-dimensional quantitative structure-activity relationships from molecular similarity matrices and genetic neural networks. 2. Applications," *J. Med. Chem.* 1997 Dec 19;40(26):4360-71.
117. Johnson M.K., "The mechanism of delayed neuropathy caused by some organophosphorus esters: using the understanding to improve safety," *J. Environ. Sci. Health [B].* 1980;15(6):823-41.
118. Organization of Economic and Commercial Development, "Acute Inhalation Toxicity," OECD Test Guideline 403, Adopted 12 May 1981, Paris, France.
119. Tsuchiya T., et al. "Improved sensitivity and decreased sample size in a cytotoxicity test for biomaterials: a modified colony microassay using a microplate and crystal violet staining," *J. Appl. Biomater.* 1994 Winter;5(4):361-7.
120. Seeley M.R., et al., "Toxicity of four alkylating agents on in vitro rat embryo differentiation and development," *Fundam. Appl. Toxicol.* 1995 Jun; 26(1): 136-142.
121. Iigo M., et al. "Antagonistic effect of polyinosinic-polycytidylic acid on the cell lethality produced by 5-fluorouracil in human colon carcinoma cells in vitro," *Cancer Res.* 1985 May; 45(5): 1953-1957.
122. Rogers C.G., et al., "In vitro cytotoxicity of polychlorinated biphenyls (Aroclors 1016, 1242, 1254 and 1260) and their effect on phospholipid and neutral lipid composition of Chinese hamster ovary (CHO-K1) cells," *Toxicology.* 1983 Feb; 26(2): 113-124.
123. O'Rourke E.J., et al., "Specific lethality of silica for human peripheral blood mononuclear phagocytes, in vitro," *J. Immunol. Methods.* 1978; 19(2-3): 137-151.
124. Dewey W.C., et al., "Comparison of lethality and chromosomal damage induced by x-rays in synchronized Chinese hamster cells in vitro," *Radiat. Res.* 1970 Sep; 43(3): 561-581.

-
125. Reinhardt C.A., "Do we find relevant parameters for in vitro cytotoxicity testing?" *Mol Toxicol.* 1987; 1(4): 383-391
 126. Song X., et al., "Modeling the developmental neurotoxicity of chlorpyrifos in vitro: macromolecule synthesis in PC12 cells," *Toxicol. Appl. Pharmacol.* 1998 Jul; 151(1): 182-191.
 127. Calderon F.H., et al., "Toxic effects of acetylcholinesterase on neuronal and glial-like cells in vitro," *Mol. Psychiatry.* 1998 May; 3(3): 247-255.
 128. Harry G.J., et al., "In vitro techniques for the assessment of neurotoxicity. *Environ. Health. Perspect.* 1998 Feb; 106 Suppl 1: 131-158.
 129. Binding N., et al., "Prediction of neurotoxic potency of hazardous substances with a modular in vitro test battery," *Toxicol. Lett.* 1996 Nov; 88(1-3): 115-120.
 130. Clapp I., et al., "Excitotoxic neurotoxicity in an in vitro brain slice model," *Biochem. Soc. Trans.* 1995 Nov; 23(4): 602S.
 131. Green S., "Validation and in vitro neurotoxicity," *Clin. Exp. Pharmacol. Physiol.* 1995 May; 22(5): 383-384.
 132. Abdulla E.M., et al., "Workshop on in vitro neurotoxicity testing: the obstacles, the way forward," *Clin. Exp. Pharmacol. Physiol.* 1995 Apr; 22(4): 277-280.
 133. Abdulla E.M., et al. "Use of neurite outgrowth as an in vitro method of assessing neurotoxicity. *Ann. N Y Acad. Sci.* 1993 May 28; 679: 276-279.
 134. Veronesi B., "In vitro screening batteries for neurotoxicants," *Neurotoxicology.* 1992; 13(1): 185-195.
 135. Harvey A.L., "Possible developments in neurotoxicity testing in vitro," *Xenobiotica.* 1988 Jun; 18(6): 625-632.
 136. Gettings S.D., et al. "A comparison of low volume, Draize and in vitro eye irritation test data. III. Surfactant-based formulations." *Food. Chem. Toxicol.* 1998 Mar; 36(3): 209-231.
 137. Curren R.D., et al. "In vitro alternatives for ocular irritation." *Environ. Health Perspect.* 1998 Apr; 106 Suppl 2: 485-492.
 138. Demetrulias J., et al., "Skin2--an in vitro human skin model: the correlation between in vivo and in vitro testing of surfactants." *Exp. Dermatol.* 1998 Feb; 7(1): 18-26.
 139. Kruszewski F.H., et al. "Evaluation of a human corneal epithelial cell line as an in vitro model for assessing ocular irritation." *Fundam. Appl. Toxicol.* 1997 Apr; 36(2): 130-140.
 140. Feder P., et al. "Statistical planning and analysis considerations in the evaluation of in vitro alternatives to whole animal use for eye irritation testing." *Food Chem. Toxicol.* 1997 Jan; 35(1): 167-174. Review.
 141. Goffin V., et al. "Comparison of in vitro predictive tests for irritation induced by anionic surfactants." *Contact Dermatitis.* 1995 Jul; 33(1): 38-41.

-
142. Pasternak A.S., et al. "First-order toxicity assays for eye irritation using cell lines: parameters that affect in vitro evaluation." *Fundam. Appl. Toxicol.* 1995 May; 25(2): 253-263.
143. van de Sandt J.J., et al. "Release of arachidonic and linoleic acid metabolites in skin organ cultures as characteristics of in vitro skin irritancy." *Fundam. Appl. Toxicol.* 1995 Apr; 25(1): 20-28.
144. Ponc M., et al. "Use of human skin recombinants as an in vitro model for testing the irritation potential of cutaneous irritants." *Skin Pharmacol.* 1995; 8(1-2): 49-59.
145. Muller-Decker K., et al., "Keratinocyte-derived proinflammatory key mediators and cell viability as in vitro parameters of irritancy: a possible alternative to the Draize skin irritation test." *Toxicol. Appl. Pharmacol.* 1994 Jul; 127(1): 99-108.
146. Wilhelm K.P., et al. "Quantitative in vitro assessment of N-alkyl sulphate-induced cytotoxicity in human keratinocytes (HaCaT). Comparison with in vivo human irritation tests." *J. Dermatol.* 1994 Jan; 130(1): 18-23.
147. Green S., et al. "Criteria for in vitro alternatives for the eye irritation test." *Food Chem. Toxicol.* 1993 Feb; 31(2): 81-85. Review.
148. Kato I., et al. "An in vitro model for assessing muscle irritation of antibiotics using rat primary cultured skeletal muscle fibers." *Toxicol. Appl. Pharmacol.* 1992 Dec; 117(2): 194-199.
149. Gautheron P., et al. "Bovine corneal opacity and permeability test: an in vitro assay of ocular irritancy." *Fundam. Appl. Toxicol.* 1992 Apr; 18(3): 442-449.
150. Harvell J., et al. "In vitro skin irritation assays: relevance to human skin." *J. Toxicol. Clin. Toxicol.* 1992; 30(3): 359-369.
151. Bason M.M., et al. "Skin irritation. In vitro assays." *Int. J. Dermatol.* 1991 Sep; 30(9): 623-626. Review. No abstract available.
152. Sugai S., et al. "Studies on eye irritation caused by chemicals in rabbits--II. An in vitro testing method using rat red blood cells for the prediction of eye irritation potential of chemicals." *J. Toxicol. Sci.* 1991 Aug; 16(3): 131-144.
153. Bruner L.H., et al "Evaluation of seven in vitro alternatives for ocular safety testing." *Fundam. Appl. Toxicol.* 1991 Jul; 17(1): 136-149. CIT.
154. Cinelli S., et al. "Alternative methods in toxicology tests: in vitro toxicity." *Cytotechnology.* 1991; 5 Suppl. 1: 51-54.
155. Galeev F.S., et al. [Effect of general anesthesia and its components on lipid peroxidation in vitro and in vivo]. *Anesteziol Reanimatol.* 1987 Jul; 4: 14-18. Russian.
156. Ueda I., et al. "Kinetic and thermodynamic aspects of the mechanism of general anesthesia in a model system of firefly luminescence in vitro." *Anesthesiology.* 1973 May; 38(5): 425-436.
157. Miller J.R., et al. "In vitro and in vivo responses of the uterus to halothane anesthesia." *Anesth. Analg.* 1966 Sep; 45(5): 583-589.
158. Parish W.E. "Evaluation of in vitro predictive tests for irritation and allergic sensitization." *Food Chem. Toxicol.* 1986 Jun; 24(6-7): 481-494. Review.

-
159. Arimura M., et al. "Experimental study for the development of an in vitro test for contact allergens. 2. Comparison of the in vitro sensitization test with the guinea pig maximization test for contact allergens. *Int. Arch. Allergy Immunol.* 1998 Mar; 115(3): 228-234.
160. Bobka C.A., et al. "Comparison of in vivo and in vitro measures of beryllium sensitization. *J. Occup. Environ. Med.* 1997 Jun; 39(6): 540-547.
161. Mitchell R.W., et al. "Effect of immune sensitization on stimulated ACh release from trachealis muscle in vitro." *Am. J. Physiol.* 1993 Jul; 265(1 Pt 1): L13-L18.
162. Niedbala W., et al. "In vitro sensitization for human monoclonal antibody production." *Immunol. Lett.* 1993 Feb; 35(2): 93-100.
163. Kroeger E.A., et al. "Effect of active sensitization on canine airway smooth muscle responsiveness to adrenergic and cholinergic mechanisms in vitro." *Prog. Clin. Biol. Res.* 1988; 263: 219-230.
164. White L.L., et al. "In vitro sensitization using thymocyte conditioned medium prepared from fetal calf, horse and rabbit sera." *Immunol. Lett.* 1987 Jan; 14(2): 87-89.
165. Russell K.J., et al. "In vitro and in vivo radiation sensitization by the halogenated pyrimidine 5-chloro-2'-deoxycytidine." *Cancer Res.* 1986 Jun; 46(6): 2883-2887.
166. Pfaller W., et al. "Nephrotoxicity testing in vitro--what we know and what we need to know." *Environ. Health Perspect.* 1998 Apr; 106 Suppl 2: 559-569. Review.
167. Mugford C.A., et al. "Contribution of oxidation and deacetylation to the bioactivation of acetaminophen in vitro in liver and kidney from male and female Sprague-Dawley rats." *Drug Metab. Dispos.* 1995 Feb; 23(2): 290-294.
168. Steinmassl D., et al. "LLC-PK1 epithelia as a model for in vitro assessment of proximal tubular nephrotoxicity." *In Vitro Cell Dev. Biol. Anim.* 1995 Feb; 31(2): 94-106.
169. Kruidering M., et al. "Evaluation of nephrotoxicity in vitro using a suspension of highly purified porcine proximal tubular cells and characterization of the cells in primary culture." *Exp. Nephrol.* 1994 Nov; 2(6): 324-344.
170. Trifillis A.L., et al. "Use of human renal proximal tubule cell cultures for studying foscarnet-induced nephrotoxicity in vitro." *Antimicrob. Agents Chemother.* 1993 Nov; 37(11): 2496-2499.
171. Jiang T., et al. "An in vitro model of cyclosporine-induced nephrotoxicity." *Fundam Appl. Toxicol.* 1993 May; 20(4): 486-495.
172. Trevisan A., et al. "Sex- and age-related nephrotoxicity due to 1,2-dichloropropane in vitro. *Arch. Toxicol.* 1992; 66(9): 641-645.
173. Wilks M.F., et al. "Assessment of heavy metal nephrotoxicity in vitro using isolated rat glomeruli and proximal tubular fragments." *Ren. Physiol. Biochem.* 1990 Sep; 13(5): 275-284.
174. Boogaard P.J., et al. "Primary culture of proximal tubular cells from normal rat kidney as an in vitro model to study mechanisms of nephrotoxicity. Toxicity of

-
- nephrotoxicants at low concentrations during prolonged exposure.” *Biochem. Pharmacol.* 1990 Apr 15; 39(8): 1335-1345.
175. Castaing N., et al. [Methods of in vitro evaluation for nephrotoxicity]. *J Toxicol. Clin. Exp.* 1990 Mar; 10(2): 73-87. Review. French.
176. Tinker, John F., “Relating Bacterial Mutagenesis Activity to Chemicals Structure,” in Golberg, Leon, editor, *Structure-Activity Correlation as a Predictive Tool in Toxicology*, Hemisphere Publishing, Washington, DC, 1983, pg. 207.
177. Tafazoli M., et al. “In vitro mutagenicity and genotoxicity study of a number of short-chain chlorinated hydrocarbons using the micronucleus test and the alkaline single cell gel electrophoresis technique (Comet assay) in human lymphocytes: a structure-activity relationship (QSAR) analysis of the genotoxic and cytotoxic potential.” *Mutagenesis.* 1998 Mar; 13(2): 115-126.
178. Benigni R. “Mouse bone marrow micronucleus assay: relationships with in vitro mutagenicity and rodent carcinogenicity.” *J. Toxicol. Environ. Health.* 1995 Jul; 45(3): 337-347.
179. Benigni R., et al. “Relationships among in vitro mutagenicity assays: quantitative vs. qualitative test results.” *Environ. Mol. Mutagen.* 1995; 26(2): 155-162.
180. Benigni R., et al. “Rodent carcinogenicity and toxicity, in vitro mutagenicity, and their physical chemical determinants.” *Mutat. Res.* 1993 Oct; 297(3): 281-292.
181. Kulka U., et al. “Development of short-term mutagenicity test systems in vitro: metabolic activation of indirectly acting mutagens by three immortal rat hepatocyte lines.” *Mutagenesis.* 1993 May; 8(3): 193-197.
182. Benigni R. “Relationships between in vitro mutagenicity assays.” *Mutagenesis.* 1992 Sep; 7(5): 335-341.
183. Legator M.S., et al. “Mutagenicity screening/in vitro testing--the end of an era; animal and human studies--the direction for the future.” *Ann. N Y Acad. Sci.* 1988; 534: 833-844. Review.
184. Valentino R.J., et al. “Prediction of drug sensitivity in individuals with atypical serum cholinesterase based on in vitro biochemical studies.” *Biochem. Pharmacol.* 1981 Jun 15; 30(12): 1643-1649.
185. Chin B.H., et al. “Automated method for determining in vitro cholinesterase inhibition by experimental insecticide candidates.” *J. Agric. Food Chem.* 1980 Nov; 28(6): 1342-1344.
186. Simon G, et al. “The effect of sympatholytic and sympathomimetic agents on acetylcholinesterase and cholinesterase activity, in vitro.” *Biochem Pharmacol.* 1976 Apr 15; 25(8): 881-882.
187. Lentz T.L. “Nerve trophic function: in vitro assay of effects of nerve tissue on muscle cholinesterase activity.” *Science.* 1971 Jan 15; 171(967): 187-189.
188. Back P. [Reactivation of acetylcholinesterase and cholinesterase. Titrimetric studies on brain homogenate and plasma after in vitro inhibition by Tabun, Sarin and Soman]. *Z. Klin. Chem. Klin. Biochem.* 1969 May; 7(3): 301-305. German.

-
189. Failli, P., Fazzini, A., Franconi, F., Stendardi, I., Giotti, A., "Taurine Antagonizes the Increase in Intracellular Calcium concentration Induced by Alpha-Adrenergic Stimulation in Freshly Isolated Guinea-Pig Cardiomyocytes," *Journal of Molecular and Cellular Cardiology*, Vol. 24, pp. 1253-1265, 1992.
190. Woosley, R. L., chen, Y., Freiman, J. P., Gillis, R. A., "Mechanism of the Caridotoxic Actions of Terfenadine," *Journal of American Medical Association*, Vol. 269, pp. 1532-1536, 1993.
191. Lechner, R. B., "Naloxone Potentiates Inotropic But Not Chronotropic Effects of Isoproterenol In Vitro," *Circulatory Shock*, Vol. 39, pp. 226-230, 1993.
192. Wolf W.J., et al. "Comparison of the in vitro myocardial depressant effects of isoflurane and halothane anesthesia." *Anesthesiology*. 1988 Nov; 69(5): 660-666.
193. Heerdt P.M., et al. "Effect of halothane on in vivo and in vitro cardiotoxicity of an aminocardenolide." *J. Cardiovasc Pharmacol*. 1994 Jun; 23(6): 890-896.
194. Wondergem J., et al. "In vitro assessment of cardiac performance after irradiation using an isolated working rat heart preparation." *Int. J. Radiat. Biol*. 1991 Apr; 59(4): 1053-1068.
195. Eledjam J.J., et al. "In vitro study on mechanisms of bupivacaine-induced depression of myocardial contractility." *Anesth. Analg*. 1989 Dec; 69(6): 732-735.
196. Dorr R.T., et al. "In vitro rat myocyte cardiotoxicity model for antitumor antibiotics using adenosine triphosphate/protein ratios." *Cancer Res*. 1988 Sep 15; 48(18): 5222-5227.
197. Castell J.V., et al. "In vitro investigation of the molecular mechanisms of hepatotoxicity." *Arch. Toxicol. Suppl*. 1997; 19: 313-321. Review.
198. Sweeny, D. J., and Diasio, R. B., "The Isolated Hepatocyte and Isolated Perfused Liver as Models for Studying Drug- and Chemical-Induced Hepatotoxicity," in *Hepatotoxicity*, Meeks, R. G., Harrison, S. D., and Bull, R. J., editors, CRC Press, Boca Raton, Florida, pp. 215-239, 1991.
199. Plaa, G. L., and Charabonneau, M., "Detection and Evaluation of chemically Induced Liver Injury," in *Principles and Methods of Toxicology*, 3rd Edition, Hayes, A. W., editor, Raven Press, New York, NY, pp. 839-870, 1994.
200. McQueen, C. A., and Williams, G. M., "Toxicology Studies in cultured Hepatocytes From Various Species," in *The Isolated Hepatocyte. Use in Toxicology and Xenobiotic Biotransformations*, Rauckman, E. J. and Padilla, G. M., Academic Press, New York, NY, pp. 51-67, 1987.
201. Ferro M. "Hepatoma cell cultures as in vitro models for hepatotoxicity." *Methods Mol. Biol*. 1995; 43: 51-57.
202. Hall T.J., et al. "Development of an in vitro hepatotoxicity assay for assessing the effects of chronic drug exposure." *Res. Commun. Chem. Pathol. Pharmacol*. 1993 Feb; 79(2): 249-256.
203. Tyson C.A., et al. "Correlations of in vitro and in vivo hepatotoxicity for five haloalkanes." *Toxicol Appl Pharmacol*. 1983 Sep 15; 70(2): 289-302.

-
204. Webster W.S., et al. "A review of the contribution of whole embryo culture to the determination of hazard and risk in teratogenicity testing." *Int. J. Dev. Biol.* 1997 Apr;41(2):329-35. Review.
205. Courage-Maguire C., et al. "Correlation of in vitro anti-proliferative potential with in vivo teratogenicity in a series of valproate analogues." *Int. J. Dev. Neurosci.* 1997 Feb;15(1):37-43.
206. Andrews J.E., et al. "Validation of an in vitro teratology system using chiral substances: stereoselective teratogenicity of 4-yn-valproic acid in cultured mouse embryos." *Toxicol. Appl. Pharmacol.* 1995 Jun;132(2):310-6.
207. Bechter R. "The validation and use of in vitro teratogenicity tests." *Arch. Toxicol. Suppl.* 1995;17:170-91. Review.
208. Ritchie H., et al. "Parameters determining isotretinoin teratogenicity in rat embryo culture." *Teratology.* 1991 Jan;43(1):71-81.
209. Daston G.P. "Ethylenethiourea: in vivo/in vitro comparisons of teratogenicity." *Teratology.* 1990 Apr;41(4):475-8.
210. Kistler A., et al. "Testing of retinoids for teratogenicity in vitro: use of micromass limb bud cell culture." *Methods Enzymol.* 1990;190:427-33.
211. Fujinaga M., et al. "Rat whole embryo culture: an in vitro model for testing nitrous oxide teratogenicity." *Anesthesiology.* 1988 Sep;69(3):401-4.
212. Cicurel L., et al. "Post-implantation embryo culture: validation with selected compounds for teratogenicity testing." *Xenobiotica.* 1988 Jun;18(6):617-24.
213. Brown NA. "Teratogenicity testing in vitro: status of validation studies." *Arch Toxicol Suppl.* 1987;11:105-14. Review.
214. Goldberg, A. M. and Frazier, J. M., "Alternatives to Animals in Toxicity Testing," *Scientific American*, vol. 261, 1989, pg. 24-30.
215. Vesely, D., Vesela, D., and Jelinek, R., "Nineteen Mycotoxins Tested in Chicken Embryos," *Toxicology Letters*, Vol. 13, pp. 239-245, 1982.
216. Weil, E.D., "Phosphorous-Based Flame Retardants," In: *Handbook of Organophosphorous Chemistry*, Engel, R., ed., Marcel Dekker, Inc., N.Y., 1992, pp 683-738.
217. Fisher, E.M., "Chemical Flame Suppression by Phosphorus-Containing Compounds," Presentation at: the Annual Research Meeting of Next Generation Fire Suppression Technology Program, Rockville, MD, June 29-July 1, 1998.
218. Huie, R.E., "Environmental Impact of New Chemical Agents for Fire Suppression, Presentation at: the Annual Research Meeting of Next Generation Fire Suppression Technology Program, Rockville, MD, June 29-July 1, 1998.
219. Lide, D.R. and Milne, G.W.A., Eds., *Handbook of Data on Common Organic Compounds II*, CRC Press, Boca Raton, 1995.
220. Environ Corp. "Elements of Toxicology," *Chem. Eng. Progress*, 1989Aug.: 37-46.

-
221. Dunnick J.K., Solleveld H.A., Harris M.W., Chapin R., Lamb J.C. 4th, "Dimethyl methyl phosphonate induction of dominant lethal mutations in male mice," *Exp. Mol. Pathol.* 1984 Aug;41(1):126-140.
222. Dunnick J.K., Eustis S.L., Haseman J.K., "Development of kidney tumors in the male F344/N rat after treatment with dimethyl methylphosphonate," National Institute of Environmental Health Sciences, National Toxicology Program, Research Triangle Park, North Carolina 27709.
223. Rowland, J. C.; Brower, M. E.; Roberts, W. C., "Health Advisory for Dimethyl Methylphosphonate (DMMP)," Environmental Protection Agency, Washington, DC. Office of the Assistant Administrator for Water.; Army Medical Research and Development Command, Fort Detrick, MD. NTIS Order Number: PB93-117018INZ, Sept. 92.
224. Lewis, R. J., Sr., *Sax's Dangerous Properties of Industrial Materials*, Ninth Edition, Van Nostrand Reinhold, New York, 1996, p. 1257.
225. Lewis, R. J., Sr., *Sax's Dangerous Properties of Industrial Materials*, Ninth Edition, Van Nostrand Reinhold, New York, 1996, p. 3267.
226. Lewis, R. J., Sr., *Sax's Dangerous Properties of Industrial Materials*, Ninth Edition, Van Nostrand Reinhold, New York, 1996, p. 1965.
227. Lewis, R. J., Sr., *Sax's Dangerous Properties of Industrial Materials*, Ninth Edition, Van Nostrand Reinhold, New York, 1996, p. 1501.
228. Bare, J. C., Simulation of Performance of Chlorine-Free Fluorinated Ethers and Fluorinated Hydrocarbons to Replace CFC-11 and CFC-114 in Chillers, Environmental Protection Agency, Research Triangle Park, NC. Air and Energy Engineering Research Lab., NTIS Order Number: PB93-175511INZ., 1993.
229. Kopko, W. L., "Beyond CFCs: Extending the Search for New Refrigerants," presented at the 1989 ASHRAE CFC Technology conference, Gaithersburg, MD, USA, 27-28 September 1989.
230. Simons, C. W., O'Neill, G. J., Gribens, J. A., "Aerosol propellants for personal products," US Patent 4,041,148. Assigned to W. R. Grace, 1977.
231. Simons, C. W., O'Neill, G. J., Gribens, J. A., "Aerosol propellants for personal products," US Patent 4,139,607. Assigned to W. R. Grace, 1979.
232. Hodge, H. C., Smith, F. A., and Chen, P. S., "Structure-Toxicity Relations," In: Volume III, Biological Effects of Organic Fluorides, J. H. Simons, Editor, Academic Press, 1963.
233. Burns, T. H. S., Hall, J. M., Bracken, A., and Gouldstone, G., "Fluorine Compounds in Anaesthesia," *Anesthesia*, Vol. 37, 278-284, 1982.
60. Robbins, B. H., "Preliminary Studies of the Anesthetic activity of Fluorinated Hydrocarbons," *J. Pharmacol Exp. Ther.*, Vol. 86, 197-206, 1946.
235. Booth, H. S., "Halogenated Methyl Ethers," US Patent 2,066,905, Assigned to Westinghouse, 1937.
236. Krantz, J. C., Jr. and Rudo, F. G., "The Fluorinated Anesthetics," Chapter 10, ?

237. Davies, R. H., Bagnell, R. D., Bell, W., and Jones, W. G. M., "The Hydrogen Bond Proton Donor Properties of Volatile Halogenated Hydrocarbons and Ethers and Their Mode of Action in Anaesthesia," *Int. J. Quantum Chem: Quantum Biology Symp.* No. 3, 171-185, 1976.

NIST-114 (REV. 6-93) ADMAN 4.09		U.S. DEPARTMENT OF NATIONAL INSTITUTE OF STANDARDS AND TECHNOLOGY		(ERB USE ONLY)																																																														
MANUSCRIPT REVIEW AND APPROVAL				ERB CONTROL NUMBER G		DIVISION																																																												
				PUBLICATIONS REPORT NUMBER No. NISTIR 6323		CATEGORY CODE																																																												
INSTRUCTIONS: ATTACH ORIGINAL OF THIS FORM TO ONE (1) COPY OF MANUSCRIPT AND SEND TO: WEBB SECRETARY, BUILDING 820, ROOM 125				PUBLICATION DATE April 1999		NO. PRINTED PAGES																																																												
TITLE AND SUBTITLE (CITE IN FULL) Screening Methods for Agent Compatibility with People, Materials, and the Environment																																																																		
CONTRACT OR GRANT NUMBER				TYPE OF REPORT AND/OR PERIOD COVERED																																																														
AUTHOR(S) (LAST NAME, FIRST INITIAL, SECOND INITIAL) Nyden, Marc R. Skaggs, Stephanie, R.				PERFORMING ORGANIZATION (CHECK (X) ONE BOX) <input checked="" type="checkbox"/> NIST/GAITHERSBURG <input type="checkbox"/> NIST/BOULDER <input type="checkbox"/> NIST/JILA																																																														
LABORATORY AND DIVISION NAMES (FIRST NIST AUTHOR ONLY) Building and Fire Research Laboratory, Fire Science Division																																																																		
SPONSORING ORGANIZATION NAME AND COMPLETE ADDRESS (STREET, CITY, STATE, ZIP)																																																																		
<table border="0"> <tr> <td colspan="3">PROPOSED FOR NIST PUBLICATION</td> <td colspan="3">MONOGRAPH (NIST MN)</td> <td colspan="3">LETTER CIRCULAR</td> </tr> <tr> <td><input type="checkbox"/></td><td>JOURNAL OF RESEARCH (NIST JRES)</td> <td><input type="checkbox"/></td><td>NATL. STD. REF. DATA SERIES (NIST NSRDS)</td> <td><input type="checkbox"/></td><td>BUILDING SCI. SERIES</td> <td><input type="checkbox"/></td><td>PRODUCT STANDARDS</td> <td><input type="checkbox"/></td><td>OTHER</td> </tr> <tr> <td><input type="checkbox"/></td><td>J. PHYS. & CHEM. REF. DATA (JPCRD)</td> <td><input type="checkbox"/></td><td>FEDERAL INFO. PROCESS. STDS. (NIST FIPS)</td> <td><input type="checkbox"/></td><td>LIST OF PUBLICATIONS (NIST LP)</td> <td><input type="checkbox"/></td><td>—</td> <td><input type="checkbox"/></td><td>—</td> </tr> <tr> <td><input type="checkbox"/></td><td>HANDBOOK (NIST HB)</td> <td><input checked="" type="checkbox"/></td><td>INTERAGENCY/INTERNAL REPORT (NISTIR)</td> <td><input type="checkbox"/></td><td>—U.S.</td> <td><input type="checkbox"/></td><td>FOREIGN—</td> <td><input type="checkbox"/></td><td>—</td> </tr> <tr> <td><input type="checkbox"/></td><td>SPECIAL PUBLICATION (NIST SP)</td> <td></td><td></td> <td></td><td></td> <td></td><td></td> <td></td><td></td> </tr> <tr> <td><input type="checkbox"/></td><td>TECHNICAL NOTE (TN)</td> <td></td><td></td> <td></td><td></td> <td></td><td></td> <td></td><td></td> </tr> </table>								PROPOSED FOR NIST PUBLICATION			MONOGRAPH (NIST MN)			LETTER CIRCULAR			<input type="checkbox"/>	JOURNAL OF RESEARCH (NIST JRES)	<input type="checkbox"/>	NATL. STD. REF. DATA SERIES (NIST NSRDS)	<input type="checkbox"/>	BUILDING SCI. SERIES	<input type="checkbox"/>	PRODUCT STANDARDS	<input type="checkbox"/>	OTHER	<input type="checkbox"/>	J. PHYS. & CHEM. REF. DATA (JPCRD)	<input type="checkbox"/>	FEDERAL INFO. PROCESS. STDS. (NIST FIPS)	<input type="checkbox"/>	LIST OF PUBLICATIONS (NIST LP)	<input type="checkbox"/>	—	<input type="checkbox"/>	—	<input type="checkbox"/>	HANDBOOK (NIST HB)	<input checked="" type="checkbox"/>	INTERAGENCY/INTERNAL REPORT (NISTIR)	<input type="checkbox"/>	—U.S.	<input type="checkbox"/>	FOREIGN—	<input type="checkbox"/>	—	<input type="checkbox"/>	SPECIAL PUBLICATION (NIST SP)									<input type="checkbox"/>	TECHNICAL NOTE (TN)								
PROPOSED FOR NIST PUBLICATION			MONOGRAPH (NIST MN)			LETTER CIRCULAR																																																												
<input type="checkbox"/>	JOURNAL OF RESEARCH (NIST JRES)	<input type="checkbox"/>	NATL. STD. REF. DATA SERIES (NIST NSRDS)	<input type="checkbox"/>	BUILDING SCI. SERIES	<input type="checkbox"/>	PRODUCT STANDARDS	<input type="checkbox"/>	OTHER																																																									
<input type="checkbox"/>	J. PHYS. & CHEM. REF. DATA (JPCRD)	<input type="checkbox"/>	FEDERAL INFO. PROCESS. STDS. (NIST FIPS)	<input type="checkbox"/>	LIST OF PUBLICATIONS (NIST LP)	<input type="checkbox"/>	—	<input type="checkbox"/>	—																																																									
<input type="checkbox"/>	HANDBOOK (NIST HB)	<input checked="" type="checkbox"/>	INTERAGENCY/INTERNAL REPORT (NISTIR)	<input type="checkbox"/>	—U.S.	<input type="checkbox"/>	FOREIGN—	<input type="checkbox"/>	—																																																									
<input type="checkbox"/>	SPECIAL PUBLICATION (NIST SP)																																																																	
<input type="checkbox"/>	TECHNICAL NOTE (TN)																																																																	
PROPOSED FOR NON-NIST PUBLICATION (CITE FULLY):																																																																		
PUBLISHING MEDIUM:		<input type="checkbox"/> PAPER X	<input type="checkbox"/> DISKETTE	<input type="checkbox"/> CD-ROM	<input type="checkbox"/> WWW X	<input type="checkbox"/> OTHER																																																												
SUPPLEMENTARY NOTES																																																																		
<p>ABSTRACT (A 2000-CHARACTER OR LESS FACTUAL SUMMARY OF MOST SIGNIFICANT INFORMATION. IF DOCUMENT INCLUDES A SIGNIFICANT BIBLIOGRAPHY OR LITERATURE SURVEY, CITE IT HERE. SPELL OUT ACRONYMS ON FIRST REFERENCE.) (CONTINUE ON SEPARATE PAGE, IF NECESSARY.)</p> <p>A workshop on fire suppressant agent compatibility with people, materials and the environment was held at the National Institute of Standards and Technology on November 14 and 15, 1997, which was attended by approximately 40 representatives from government, academia, and industry. The participants were asked to assess currently used screening methods for each of the following properties of candidate fire suppressants: <u>environmental impact</u> (including ozone depletion potential, global warming potential, and atmospheric lifetime); <u>materials compatibility</u> (including long-term storage stability, the interaction of the agent with metals, gaskets and lubricants, and the compatibility of the agent and its combustion by-products with potentially exposed weapons systems); and <u>toxicity</u> (including acute, genetic, subchronic, developmental, and cardiac sensitization). For each property, the workshop participants compared currently used measurement methods and identified the best method for future use in screening candidates for the next generation of fire suppressants. Each of these "best current" methods was evaluated and given one of the following designations: acceptable as is, acceptable with modifications, or unacceptable. At the conclusion of the workshop, a consensus screening method was advanced for each property.</p>																																																																		
KEY WORDS (MAXIMUM OF 9; 28 CHARACTERS AND SPACES EACH; SEPARATE WITH SEMICOLONS; ALPHABETIC ORDER; CAPITALIZE ONLY PROPER NAMES) <u>compatibility with plastics; fire suppression; global warming potential; halons; long-term storage stability; metals corrosion; ozone depletion potential; screening procedures; toxicity</u>																																																																		
AVAILABILITY: <input checked="" type="checkbox"/> UNLIMITED <input type="checkbox"/> FOR OFFICIAL DISTRIBUTION - DO NOT RELEASE TO NTIS <input type="checkbox"/> ORDER FROM SUPERINTENDENT OF DOCUMENTS, U.S. GPO, WASHINGTON, DC 20402 <input checked="" type="checkbox"/> ORDER FROM NTIS, SPRINGFIELD, VA 22161				NOTE TO AUTHOR(S); IF YOU DO NOT WISH THIS MANUSCRIPT ANNOUNCED BEFORE PUBLICATION, PLEASE CHECK HERE. <input type="checkbox"/>																																																														