

**NISTIR 5800**

---

---

**Guidelines for Pre-Qualification, Prototype and  
Quality Control Testing of Seismic Isolation Systems**

---

---

Harry W. Shenton III

Building and Fire Research Laboratory  
National Institute of Standards and Technology  
Gaithersburg, Maryland 20899

January 1996



**U.S. Department of Commerce**  
Michael Kantor, *Secretary*  
**Technology Administration**  
Mary L. Good, *Under Secretary for Technology*  
National Institute of Standards and Technology  
Arati Prabhakar, *Director*



## Abstract

### Guidelines for Pre-Qualification, Prototype and Quality Control Testing of Seismic Isolation Systems

by Harry W. Shenton III\*

Testing has become an essential element in the design and construction of seismically base isolated structures. Prototype tests and quality control tests of the isolation system are currently required by the 1994 *Uniform Building Code* and the American Association of State Highway and Transportation Officials 1991 *Guide Specifications for Seismic Isolation Design*. However, standards do not exist for conducting these tests. The Building and Fire Research laboratory of the National Institute of Standards and Technology has developed guidelines for testing and evaluation of seismic isolation systems. The guidelines were developed in close cooperation with industry, researchers and practitioners. Included in this report are comprehensive guidelines for conducting pre-qualification, prototype and quality control tests of the isolation system. The guidelines are independent of the type of isolation system and application. Thus, they can be used to test elastomeric, sliding or hybrid isolation systems, for applications that involve buildings, bridges, facilities and other special structures. The guidelines include general requirements of the test facility, instrumentation, calibration, data acquisition, data analysis and reporting of results. All tests are presented in a standard format that includes the following elements: test designation, purpose, sequence, procedure, performance criteria, special requirements and exceptions. The guidelines are to serve as a resource document for voluntary standard/specification writing organizations, and for practitioners and researchers involved in the design, manufacture and testing of seismic isolation systems.

\*Department of Civil and Environmental Engineering, University of Delaware, Newark, Delaware, 19716



## **Acknowledgements**

The author would like to thank all those who provided comments and feedback on the draft guidelines for testing of seismic isolation systems. Many of the comments and suggestions have been incorporated into the final guidelines, and have made for a very comprehensive, easy to read document that should be extremely useful to the industry. The author would also like to thank, in particular, the NIST Oversight Committee for their guidance and assistance in developing these guidelines. This includes Dr. Ian Buckle, Dr. Charles Kircher, Professor James M. Kelly, Dr. Ronald Mayes and Dr. Victor A. Zayas. Their time, effort and helpful comments are greatly appreciated. The author would also like to thank all of those who participated in the July 25, 1994, workshop in San Francisco. The feedback received from the workshop discussions was particularly insightful. Finally, the author would like to thank Dr. Riley M. Chung, Dr. Arturo E. Schultz and Dr. Andrew W. Taylor, of the National Institute of Standards and Technology for their assistance with the workshop and in providing input to the final guidelines.



## TABLE OF CONTENTS

ABSTRACT .....	iii
TABLE OF CONTENTS .....	vii
LIST OF FIGURES .....	ix
LIST OF TABLES .....	xi
1. INTRODUCTION .....	1
1.1 Background .....	1
1.2 Developing the Guidelines: the Process and Industry Collaboration .....	2
1.3 Scope .....	3
1.4 Outline of the Report .....	4
2. ELASTOMERIC, SLIDING AND HYBRID SEISMIC ISOLATION SYSTEMS .	7
2.1 Elastomeric Systems .....	7
2.2 Sliding Systems .....	9
2.3 Hybrid Systems .....	10
3. RATED CAPACITY .....	17
4. GENERAL REQUIREMENTS .....	19
4.1 Introduction .....	19
4.2 Test Facility .....	19
4.3 Instrumentation and Calibration .....	23
4.4 Data Acquisition .....	24
4.5 Data Analysis .....	24
4.6 Report of Results .....	26
4.7 Independent Observer .....	26
4.8 Commentary .....	27
5. PRE-QUALIFICATION TESTS .....	37
5.1 Introduction .....	37
5.2 General Requirements of Pre-Qualification Tests .....	39
5.3 Category I - Preliminary Characterization .....	42
5.4 Category II - Ultimate and Reserve Capacity .....	61
5.5 Commentary .....	66
6. PROTOTYPE TESTS .....	79
6.1 Introduction .....	79
6.2 General Requirements of Prototype Tests .....	80
6.3 Category III - Seismic Loads .....	82
6.4 Category IV - Non-seismic Loads .....	87

7.	QUALITY CONTROL TESTS .....	95
7.1	Introduction .....	95
7.2	Elastomeric Systems .....	97
7.3	Sliding Systems .....	105
7.4	Commentary .....	111
8.	RESEARCH NEEDS IN TESTING OF SEISMIC ISOLATION SYSTEMS ...	115
8.1	Introduction .....	115
8.2	Ultimate Capacity .....	115
8.3	Aging .....	115
8.4	Delamination/Debonding in Elastomeric Isolation Bearings .....	116
8.5	Bilateral Load .....	116
8.6	Viscous and Hysteretic Damping .....	116
8.7	Load Cycle History .....	117
9.	SUMMARY .....	119
	REFERENCES .....	121
	APPENDIX A. SYMBOLS AND NOTATION .....	123
	APPENDIX B. GLOSSARY OF TERMS .....	125
	APPENDIX C. TEST FACILITIES .....	127
	APPENDIX D. DRAFT GUIDELINE FOR LONG TERM STORAGE AND TESTING OF SEISMIC ISOLATION UNITS AND COMPONENTS .....	135



## LIST OF FIGURES

Figure 2.1	Elastomeric Isolation Systems . . . . .	8
Figure 2.2	Schematic of a Generic Plane Sliding Device . . . . .	10
Figure 2.3	Sliding Isolation Systems . . . . .	12
Figure 2.4	Hybrid Isolation System: Slider with Displacement Control Device (Constantinou, et al, 1992) . . . . .	13
Figure 2.5	Hybrid Isolation System: GERB System with Steel Springs and Viscous Dampers (Huffman, 1985) . . . . .	14
Figure 2.6	Hybrid Isolation System: Alexisison System with Pot Bearing and Rubber Spring (Ikonomou, 1985) . . . . .	15
Figure 4.1	Unit or Component Under Bilateral Loading . . . . .	20
Figure 4.2	Definition Diagram . . . . .	21
Figure 4.3	Test Configurations . . . . .	22
Figure 4.4	Sample hysteresis loops . . . . .	32
Figure 4.5	Effective Stiffness and Energy Dissipation for Typical Hysteresis Loop . . . . .	33
Figure 4.6	Effective Stiffness as Measured in Various Loops . . . . .	34
Figure 4.7	Elastic-Perfectly Plastic Hysteretic Behavior . . . . .	35
Figure 5.1	Frequency Dependence and the Threshold Frequencies. . . . .	69
Figure 5.2	Load Plane Rotation. . . . .	71
Figure 5.3	Hypothetical Failure Interaction Diagrams. . . . .	76
Figure 7.1	Three-bar shear specimen . . . . .	103
Figure C.1	Isolation Unit Test Facility, Earthquake Engineering Research Center, University of California at Berkeley, Richmond, California . . . . .	128
Figure C.2	Isolation Unit Test Facility, Dynamic Isolation Systems, Inc., Berkeley, California . . . . .	129
Figure C.3	Isolation Unit Test Facility, Earthquake Protective Systems, Inc., San Francisco, California . . . . .	130
Figure C.4	Isolation Unit Test Facility, Bridgestone Corporation, Yokohama, Japan	131
Figure C.5	Isolation Unit Test Facility, Oiles Corporation, Fujisawa, Japan . . . .	132
Figure C.6	Isolation Unit Test Facility, Rockwell International, Energy Technology Engineering Center (ETEC), Canoga Park, California . . . . .	133



## LIST OF TABLES

Table 1.1	Test Categories. . . . .	5
Table 5.1	Schedule of Pre-Qualification Tests . . . . .	41
Table 6.1	Schedule of Prototype Tests . . . . .	81
Table 7.1	Schedule of Quality Control Completed Unit Tests: Elastomeric Systems .	97
Table 7.2	Schedule of Quality Control Completed Unit Tests: Sliding Systems . . .	105



# 1. INTRODUCTION

## 1.1 Background

One of the most promising concepts in seismic resistant construction to come of age this century is seismic base isolation. The premise of seismic isolation is that a structure can be decoupled from the ground, thereby reducing the effect of strong ground shaking on the structure. To decouple the structure, a flexible interface is provided at or near the foundation such that during an earthquake lateral deformations are concentrated across the isolation interface and deformations in the superstructure are minimized. In effect, the superstructure responds in a rigid body mode, with greatly reduced relative displacements, member forces and absolute acceleration. Relatively high levels of damping are also provided in the isolation system to control the displacements across the isolation interface.

Seismic isolation is applicable to most types of civil engineering structures, including buildings, bridges, water towers, nuclear power plants, and other special structures. To date, isolation has been used most often in bridges and buildings. As of 1990, the number of buildings to be isolated worldwide was estimated at 38, and the number of bridges was estimated at 51 (Buckle and Mayes, 1990). The actual numbers at that time were most likely higher, and since then have increased dramatically. It is worth noting that base isolation has become a viable alternative for seismic retrofit of existing structures. A more recent review of the state-of-practice of seismic isolation for buildings is presented by Kelly (Kelly, 1993).

There are several types of isolation systems in use today, and many more which are under development or have been proposed. Some have decades of development history, while others are still in the concept stage. In either case, at least in the United States, isolation systems are not "off-the-shelf" items, they are custom designed and built on a per project basis. Because of this, testing has become an essential element in the design and manufacture of all isolation systems. Testing is required by the *Uniform Building Code* (UBC) (Uniform, 1994) and the American Association of State Highway and Transportation Officials (AASHTO), *Guide Specifications for Seismic Isolation Design* (Guide, 1991).

At the present time two classes of tests are required by UBC and the AASHTO Guide: prototype tests and quality control (QC) tests. These may be loosely defined as follows:

**Prototype tests** are project specific and are conducted to verify the design properties of the isolation system prior to construction.

**Quality Control tests** are project specific and are conducted to verify the quality of manufacture and as-built properties of the isolation system prior to installation.

A third class of tests, referred to here as Pre-Qualification tests, are defined herein as follows:

**Pre-Qualification tests** need not be project specific and are conducted in order to establish the fundamental properties and characteristics of the isolation system,

and to determine the extent to which these properties and characteristics are dependent on load and environmental factors.

Formal pre-qualification tests as defined above are not required by the codes but are usually conducted in some form or another in the early stages of development of a new isolation system.

At the present time, standards do not exist for conducting pre-qualification, prototype or quality control tests. The need for standards was reported as a critical element in the five year research plan developed following the 1986 ATC-17 Seminar on Base Isolation and Passive Energy Dissipation (*Proceedings*, 1986). Test standards would (1) ensure the systematic characterization of isolation system properties, (2) provide a systematic method for demonstrating a minimum level of acceptable performance, and (3) enable the rational comparison of different isolation systems and components.

In response to this need the Building and Fire Research Laboratory (BFRL) of the National Institute of Standards and Technology (NIST) initiated an effort to develop guidelines (i.e., a pre-standard) for testing and evaluating seismic isolation systems, as part of BFRL's National Earthquake Hazard Reduction Program (NEHRP) effort. The guidelines contained in this report are the result of this nearly three-year effort.

## **1.2 Developing the Guidelines: the Process and Industry Collaboration**

The NIST program to develop guidelines began in October, 1992. Phase one of the plan called for developing a series of draft guidelines for testing. In phase two, the final guidelines would be developed based on industry feedback of the draft guidelines. To assist NIST in developing the draft guidelines, an Oversight Committee of industry experts was formed. The committee included individuals with expertise in the design, fabrication and testing of seismic isolation systems, and in the design of structures that incorporate seismic isolation. The committee included: Dr. Ian Buckle, Deputy Director, National Center for Earthquake Engineering Research, Buffalo, New York; Dr. Charles Kircher, Charles Kircher & Associates, Mountain View, California; Professor James M. Kelly, Department of Civil Engineering, University of California at Berkeley, Berkeley, California; Dr. Ronald Mayes, Dynamic Isolation Systems, Inc., Berkeley, California; and Dr. Victor A. Zayas, Earthquake Protective Systems, San Francisco, California. The committee helped to develop test requirements and identify relevant performance criteria, and reviewed the draft guidelines. The committee met three times between 1992 and 1993.

Draft guidelines were published in early 1994 and are presented in three NIST technical reports (Shenton, 1994a; Shenton, 1994b; Shenton, 1994c). One report is devoted to pre-qualification and prototype testing, the other two are devoted to quality control testing.

Since the time the draft guidelines were published, efforts have been made to obtain feedback on them from a broader base of practitioners, manufacturers, and researchers. This was accomplished through mail reviews, oral presentations and workshop discussions. More than 200 copies of the draft guidelines were distributed to researchers, practitioners and government agency representatives, with a request for comments. Written responses were received from more than 30 individuals. In addition, numerous presentations on the guidelines were made at various

professional meetings. This included presentations to the Structural Engineers Association of Southern California (SEAOSC), Base Isolation Subcommittee, and the American Association of State Highway and Transportation Officials (AASHTO) Subcommittee on Bridges and Structures, Technical Committee on Loads and Load Distribution. The most important feedback mechanism, however, was a national workshop, held on July 25, 1994 in San Francisco. The purpose of the workshop was to provide a forum for review and discussion of the draft guidelines. More than 30 representatives from industry, government and the research community attended. There the draft guidelines were discussed among the participants in small working groups and plenary sessions, and comments and suggested changes were recorded. The results of that workshop are reported in another NIST technical report (in review).

Feedback from the workshop, meetings and mail review have been synthesized and reviewed. The final guidelines presented herein are based on the draft guidelines, with appropriate modifications made to reflect the quasi-consensus changes recommended by the community. One obvious difference between the draft guidelines and the final guidelines is that the final guidelines are contained in one report, rather than three separate ones, as were the drafts. This was done to minimize the duplication of some material and to provide a single, concise document for use by the industry.

It is hoped that through this process the resulting guidelines will be of most use to the base isolation community and facilitate the use of this technology.

### 1.3 Scope

**The Guidelines were developed to be independent of the application and isolation system.** They are intended to be comprehensive and applicable to any isolation project, regardless of the superstructure (e.g., buildings, bridges or special structures); are intended to cover all viable isolation systems, whether they be elastomeric, sliding or hybrid; and are intended to be applicable to systems that consist of multiple isolator units, or use different components that are distributed throughout the isolation interface. The guidelines cover all pertinent tests of the isolation system or components, whether they be essential or of a secondary nature to the design of the superstructure. The guidelines encompass all critical isolation system and component areas related to structural, mechanical and environmental performance.

The broadly based guidelines included herein have several advantages over system specific procedures. First, the potential of the technology can be maximized by all subdisciplines (i.e., the building, bridge, and power industries). Second, broadly based guidelines will minimize the likelihood of each subdiscipline developing unique standards for their own application, which would only slow further progress. And finally, the guidelines do not favor one isolation system over another; therefore, they should encourage competition between various systems, resulting in production of the highest quality isolation systems.

The Guidelines are intended for systems that isolate *in the horizontal direction only*. It is assumed that the vertical load carrying system is an integral component of the isolation system, but that the vertical stiffness of it is significantly greater than the horizontal stiffness. Guidelines specific

to testing vertical isolation characteristics are not included, but such testing could be based on these guidelines with appropriate modifications. In addition, the Guidelines are intended for *passive* isolation systems only. Although it is likely that many of the tests are applicable to components of active or semi-active systems, the Guidelines were not written with these systems in mind.

The Guidelines *are not* intended to serve as a specification or manufacturing standard, nor are they intended to serve as a comprehensive quality control program. The guidelines for quality control testing outline the minimum recommended tests that should be completed *as part of* the overall quality control program. The QC tests outlined herein should be incorporated into a comprehensive program such as that recommended in the ISO 9000 standard.

The Guidelines *do not* include procedures for conducting shake table tests of the combined isolation system and superstructure. Shake table tests can be extremely valuable and are generally conducted as a new isolation system is developed. Shake table tests would be an important component of a comprehensive pre-qualification program; however, shake table tests tend to be specific to a particular application and thus are beyond the scope of the guidelines.

The guidelines for pre-qualification testing are the most comprehensive of the series, followed by prototype testing and finally quality control testing. The quality control series may be thought of as a subset of the prototype series, which in turn may be thought of as a subset of the pre-qualification series.

#### **1.4 Outline of the Report**

Presented in Chapter 2 is a brief description of some of the isolation systems and components in use or under development today. This is presented to illustrate the diversity of isolation hardware available today, and to assist, where possible, in interpretation of the guidelines. The key components of the guidelines are presented in Chapters 3 through 7.

Prior to testing, the capacity of the isolation system must be "rated". The burden of responsibility is on the supplier of the isolation system to report the fundamental properties and characteristics of the system. This includes defining the range of loads and environmental conditions in which the system can be expected to operate and function properly. The concept of rated capacity is fundamental to the guidelines and carries through from pre-qualification, to prototype, to QC testing. Details of the test procedures are based on the rated capacity of the system. A list of properties to be rated has been developed and is presented in Chapter 3.

General test requirements are presented in Chapter 4. This includes the requirements of the test facility, instrumentation, calibration, data acquisition, analysis of the data, reporting of results and the independent observer.

The test procedures outlined in the guidelines are grouped into categories, according to the nature of the test. The categories are listed in Table 1.1, along with the chapter in which they are found and the test series for which they apply. The requirements for pre-qualification testing are



presented in Chapter 5. Prototype tests are outlined in Chapter 6; quality control tests are presented in Chapter 7.

Table 1.1. Test Categories.

Category	Title	Chapter	Pre-Qualification	Prototype	Quality Control
I	Preliminary Characterization	5	X		
II	Ultimate and Reserve Capacity	5	X		
III	Seismic Loads	6	X	X	
IV	Non-Seismic Loads	6	X	X	
V	Completed Unit Quality Control	7	X	X	X

All the tests included in the guidelines are presented in a standard format. The load sequence and test parameters are specified, the test procedure is outlined and applicable performance criteria are defined. The performance criteria are rules against which the performance of the isolation system or component is measured. Systems that do not meet these criteria may not perform adequately in service.

In the course of developing the guidelines a number of issues emerged that remain to be resolved with regard to the performance and testing of seismic isolation systems. These issues are outlined in Chapter 8 under research needs. Some of these issues are critical to the development of sound guidelines and will need to be addressed in the near future so that the results can be incorporated into a revised set of guidelines or a national consensus standard. Some of these issues are currently being addressed at NIST.

A summary is presented in Chapter 9. To assist the reader a table of Symbols and Notation is contained in Appendix A, a Glossary of Terms is contained in Appendix B. Schematic drawings of several test facilities are presented in Appendix C. A tentative guideline for the long-term storage and testing of isolation units is presented in Appendix D (this procedure is included in the appendix because it falls outside the realm of pre-qualification, prototype and quality control testing, and was not included in the draft guidelines).



## 2. ELASTOMERIC, SLIDING AND HYBRID SEISMIC ISOLATION SYSTEMS

A seismic Isolation System is defined as the collection of Isolation Units, Isolation Components and all other structural elements that transfer force between the foundation/substructure and the superstructure. The Isolation System provides the lateral flexibility and damping necessary for effective isolation, and the high initial stiffness required to resist wind loads. Some systems also include an ultimate restraint or "fail-safe" mechanism that is meant to engage at very large displacements or provide back-up support in case of failure of certain Isolation Units or Components. In these guidelines an Isolation Unit is defined as a device that provides all the necessary characteristics in an integral device; an Isolation Component is defined as a device that provides some of the necessary characteristics (e.g., flexibility *or* damping) in a single device.

As mentioned previously, there are many different kinds of seismic Isolation Systems/Units and Components in use today and others are under development. Systems today are broadly grouped into three categories: elastomeric, sliding and hybrid. A brief description and examples from each of the three general categories is discussed in the sections that follow.

Note, this chapter is not meant to be a comprehensive "catalog" of all of the isolation systems in use or under development today. Furthermore, it should not be construed as an endorsement of any one system over another. The information and sketches presented have been derived, for the most part, from the open literature. This information is presented simply to assist the reader in interpreting the guidelines.

### 2.1 Elastomeric Systems

Laminated elastomeric isolation bearings are similar to elastomeric bridge bearings that have been in use for years. The bearing is fabricated by bonding layers of elastomer and steel under high temperature and pressure to form an integral bearing that is free of joints. The relative thickness of the elastomer to steel, overall height, plan dimensions and material properties are varied to achieve the desired horizontal stiffness, vertical stiffness, and damping characteristics. Two common types of laminated elastomeric bearings are shown in Figure 2.1. Presented in Figure 2.1 (a) is an ordinary laminated elastomeric bearing and in Figure 2.1 (b) is a Lead-Rubber-Bearing (LRB).

Different types of elastomer have been used in isolation bearings, including natural rubber and synthetic rubbers such as Neoprene. In ordinary laminated bearings the damping is provided by the elastomer, consequently, great effort has gone into developing high damping elastomers suitable for seismic isolation. This is usually achieved by adding fillers, such as carbon-black to the rubber. Elastomers of this type are usually referred to as high damping rubbers, so most ordinary laminated bearings today are simply referred to as High Damping Rubber (HDR) bearings.

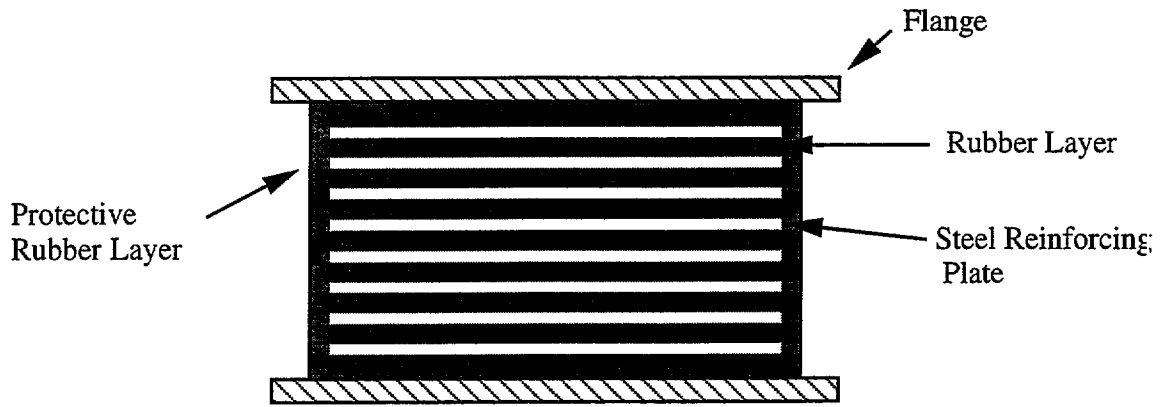

(a.) Laminated Elastomeric Bearing

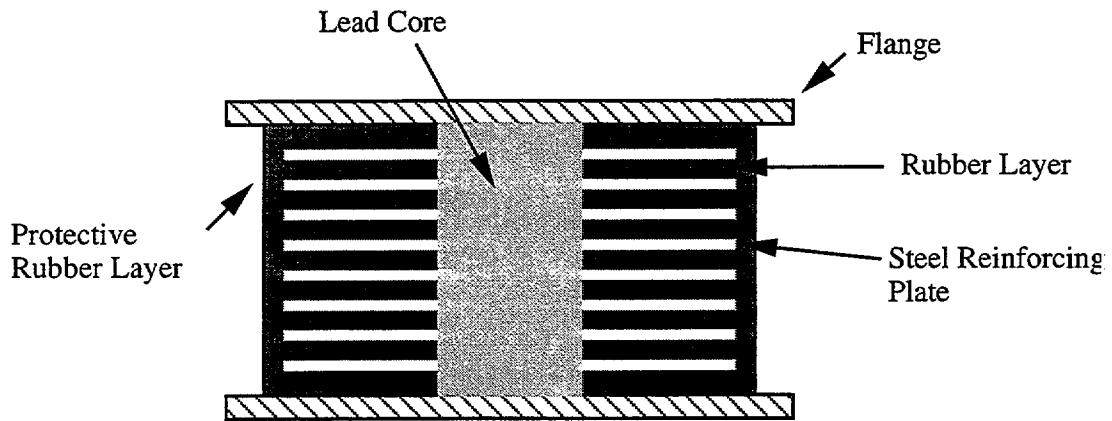

(b.) Laminated Lead-Rubber Bearing

Figure 2.1 Elastomeric Isolation Systems

The LRB is fabricated as described above, but with one or more cylindrical hollow cores through the height. After fabrication of the laminated part a lead plug is pressed into the core of the bearing. The lead core is there primarily to provide damping, and secondarily to provide lateral stiffness. The elastomer used in LRB's can be, but is not necessarily of a high damping composition.

Elastomeric bearings are usually rectangular, square or circular in plan. The connection to the foundation and superstructure can be by dowels or bolts, although in recent years bolted connections have become the design of choice. An elastomeric isolation bearing is an Isolation Unit, by the definition given previously, since the restoring force and damping mechanism are combined in a single integrated device.

## 2.2 Sliding Systems

The origin of sliding isolation systems can be found in simple Coulomb friction. By the classic law, the maximum force that can be transmitted to an object that is free to slide on an accelerating foundation is limited to the normal force times the coefficient of friction. In this way the sliding interface acts as a fuse to limit the effect of ground acceleration on the system, and under cyclic motion sliding provides the necessary damping mechanism. For an isolation system, a restoring/re-centering force must be provided to limit displacements and prevent the structure from sliding or "walking" off the bearing surface. As with elastomeric bearings, pure sliding bearings also have a history of use as bridge bearings.

The elements of a typical flat plate sliding device are illustrated in Figure 2.2. The device consists of two plate assemblies, one that is fixed and one that is free to slide relative to the fixed plate. The fixed assembly consists of a backing plate, and an interface material that will be referred to here as the "bearing pad". The bearing pad is usually recessed into the backing plate and is bolted, bonded, or bolted and bonded to the plate. The sliding assembly consists of a backing plate, and a highly polished interface material that will be referred to here as the "sliding surface". For a typical Teflon-stainless steel sliding device the bearing pad is made of Teflon (e.g., unfilled, filled or woven) and the sliding surface is a polished stainless steel. Although it can be placed on the bottom (i.e., reverse of that shown in Figure 2.2), the sliding surface is normally placed on top to keep dirt and particles from contaminating the surface. The device in Figure 2.2 would be considered an Isolation Component because it lacks a restoring force mechanism.

Other examples of sliding isolation systems include the Friction Pendulum System (FPS) (Zayas, et al. 1990) and the Resilient-Friction Base Isolation (R-FBI) System (Mostaghel and Khodaverdian, 1988). The FPS, illustrated in Figure 2.3 (a), uses a spherical stainless steel dish on which slides an articulated slider. Mounted on the bottom of the slider is a low friction composite material. The restoring force of the FPS is provided by the weight of the structure as it moves in a pendulum type motion described by the dish. The R-FBI, illustrated in Figure 2.3 (b), uses alternating layers of steel and teflon centered around an elastic rubber core. The teflon-steel frictional interface acts as a fuse and provides the necessary damping. The elastic core provides the restoring/re-centering force and can be fabricated with, or without steel

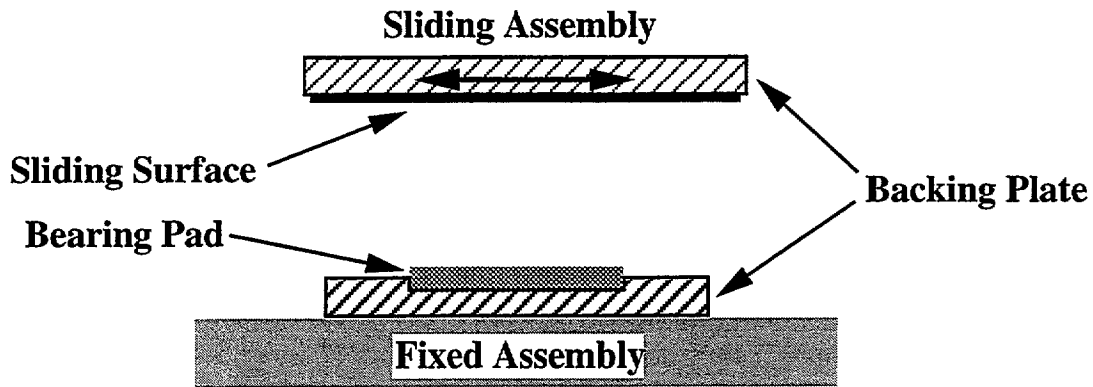

Figure 2.2. Schematic of a Generic Plane Sliding Device

reinforcement. By the definition given previously, the FPS and R-FBI are Isolation Units, because the restoring force and damping mechanism are provided in a single integrated device.

In practice the sliding interface usually consists of two dissimilar materials that have the desired coefficient of friction and wear characteristics. Throughout the years many different material combinations have been tried. Recent designs include stainless steel on teflon, stainless steel on bronze, and stainless steel on special composite materials.

### 2.3 Hybrid Systems

The majority of systems that are not primarily elastomeric or primarily sliding fall into the "catch-all" hybrid category. Hybrid systems generally use independent components to provide the restoring force, damping, wind restraint and ultimate restraint. Components can be integrated or in close proximity to each other, or distributed throughout the isolation interface. Hybrid systems sometimes include aspects of one or both of the previous classes of systems. Three systems are presented here just as examples.

Presented in Figure 2.4 is the Sliding Bearing with Displacement Control Device system (Constantinou, et al, 1992). The sliding bearing consists of an Adiprene disc, that allows for limited rotation about a horizontal axis, a shear restraint mechanism and a Teflon-stainless steel sliding interface. The Displacement Control Device uses a combination of springs and sliding friction to produce a tri-linear force deflection behavior.

Presented in Figure 2.5 is the GERB system (Huffman, 1985). This system uses helical steel springs in combination with viscous dampers. The springs and dampers can be located apart, or fabricated as an integral unit.

Presented in Figure 2.6 is the Alexisismon system (Ikonomou, 1985). This system consists of 3 basic elements: pot bearings, that carry vertical load and allow lateral movement and small rotations about a horizontal axis; rubber springs, that do not carry vertical load but provide a restoring force; and connection elements that are designed to withstand wind load and moderate earthquakes, but break or release under strong ground shaking.

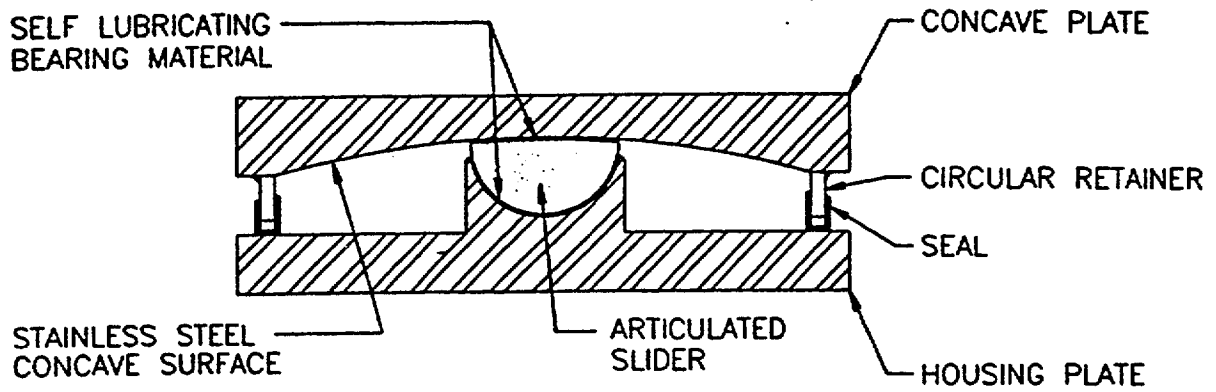

(a.) Friction Pendulum System (Zayas, et al, 1990)

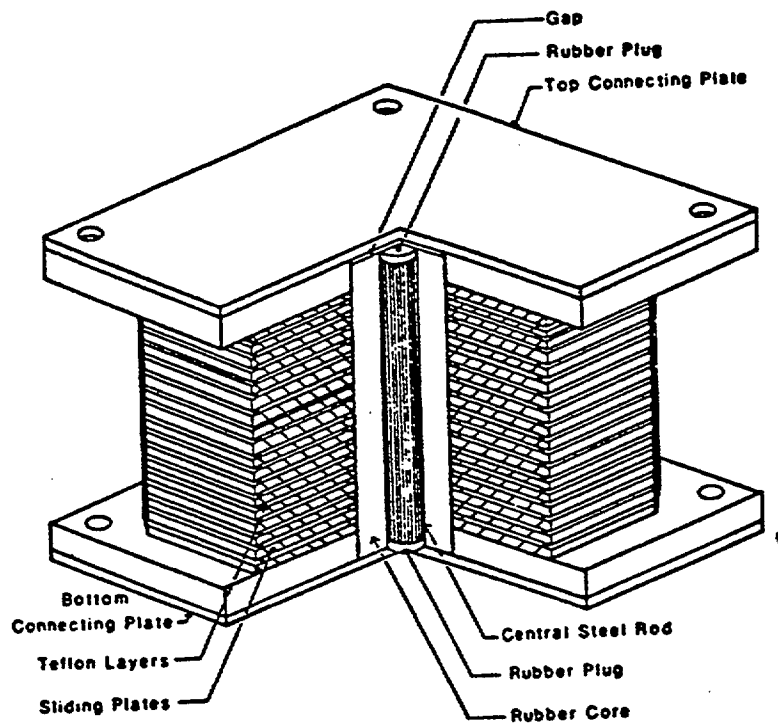

(b.) R-FBI System (Mostaghel and Khodaverdian, 1988)

Figure 2.3 Sliding Isolation Systems



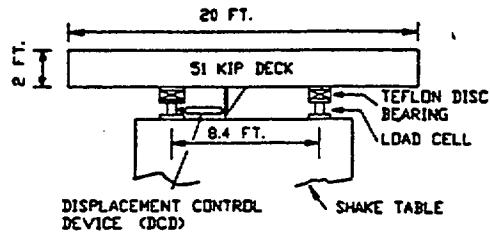

(a.) Section of Bridge Deck

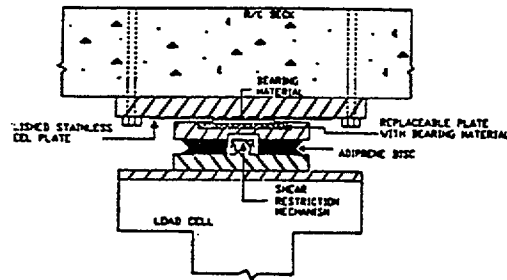

(b.) Slider

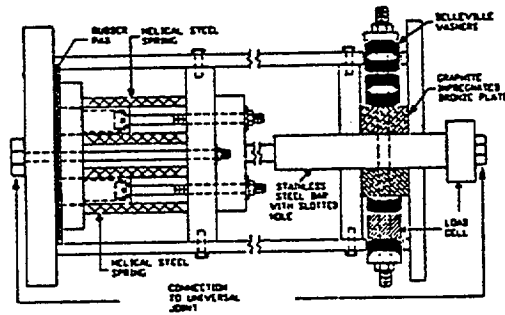

(c.) Displacement Control Device

Figure 2.4

Hybrid Isolation System: Slider with Displacement Control Device (Constantinou, et al, 1992)

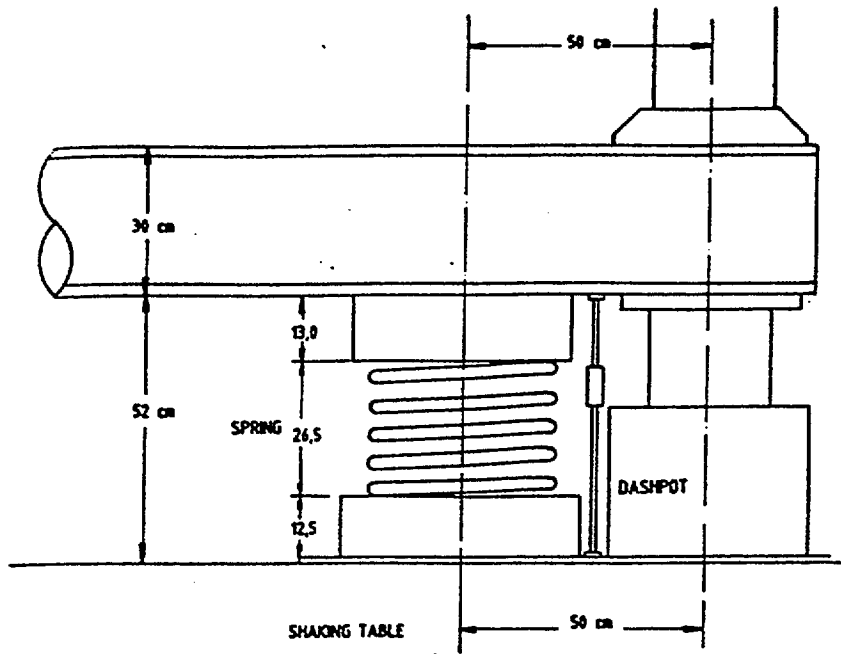

(a.) Schematic of Spring and Viscous Damper

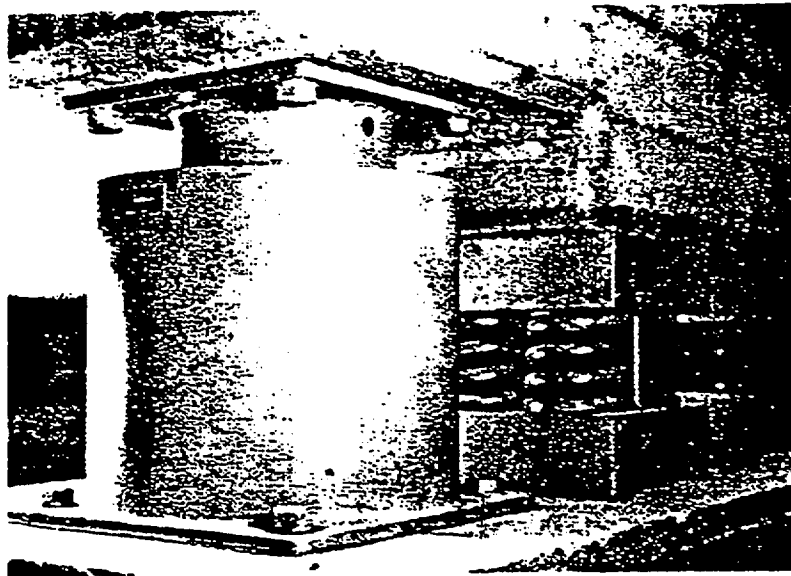

(b.) Photograph of GERB System

Figure 2.5 Hybrid Isolation System: GERB System with Steel Springs and Viscous Dampers (Huffman, 1985)

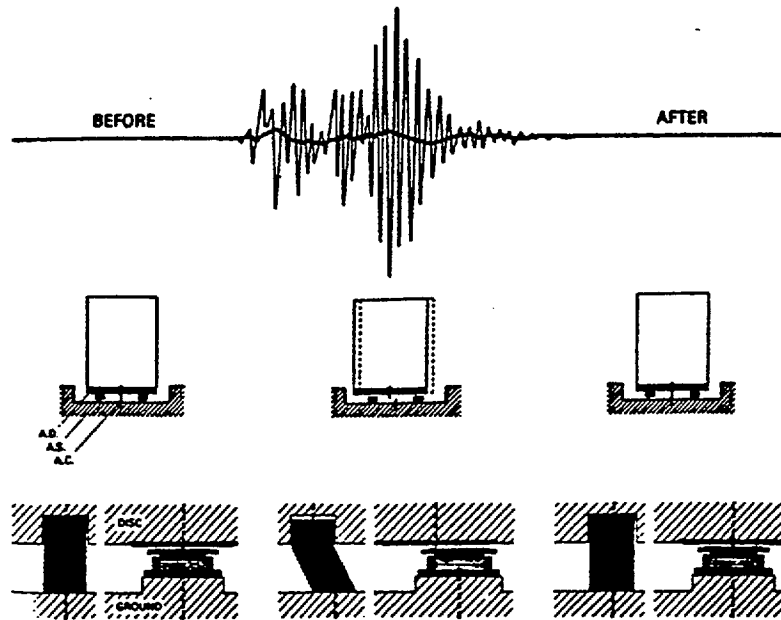

(a.) Response Illustrated During an Earthquake

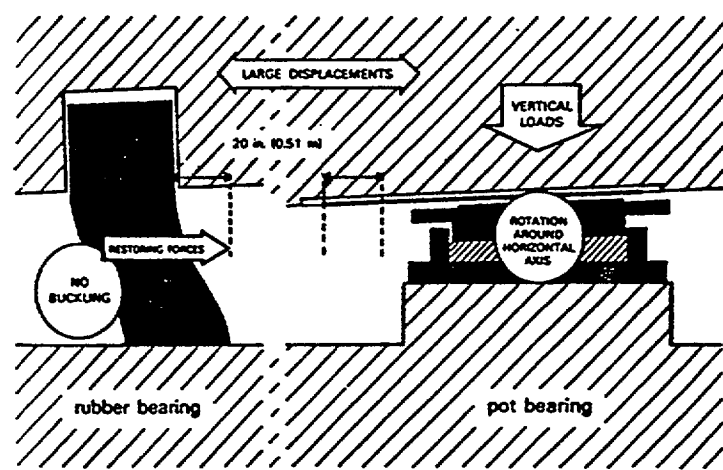

(b.) Enlarged View of System Components

Figure 2.6 Hybrid Isolation System: Alexisismon System with Pot Bearing and Rubber Spring (Ikonomou, 1985)



### 3. RATED CAPACITY

The nominal capacity of all Isolation Units and Components must be rated by the supplier prior to testing. Properties to be rated are listed below, along with the parameter notation and a short description.

Parameter	Notation	Description
Lateral Deformation:		
Design Displacement	$D$	Nominal displacement capacity.
Maximum Displacement	$D_{TM}$	Total maximum displacement capacity.
Thermal Displacement	$D_t$	Nominal thermal displacement capacity.
Vertical Deformation:		
Design Displacement	$D_v$	Nominal vertical displacement under the Design Vertical Load.
Creep Displacement	$D_c$	Long term creep displacement under the Design Vertical Load.
Rotation	$\theta$	Nominal rotation capacity about an axis in the horizontal plane, and perpendicular to the direction of lateral loading under the Design Vertical load.
Stiffness:		
Horizontal	$K_H$	Effective horizontal stiffness at the Design Displacement and Design Vertical Load.
Horizontal under Wind	$K_W$	Effective horizontal stiffness at the Design Wind Load and Design Vertical Load.
Vertical	$K_v$	Effective vertical stiffness at the Design Vertical Load.
Energy Dissipation	$E_H$	Energy dissipated per cycle at the Design Displacement and Design Vertical Load.
Vertical Load (compression):		
Low	$P_L$	Lower limit of load range for satisfactory seismic performance, includes the effect of vertical ground motion and structure overturning moment.

Parameter	Notation	Description
Design Vertical Load	$P_D$	Nominal capacity in compression, based on dead and live loads (excluding earthquake loads).
High	$P_U$	Upper limit of load range for satisfactory seismic performance, includes the effect of vertical ground motion and structure overturning moment.
Vertical Load (Tension):		
Tension	$P_T$	Nominal capacity in tension.
Lateral Load:		
Wind	$F_W$	Nominal wind load capacity.
Braking/Centrifugal load	$F_b$	Nominal braking/centrifugal load capacity.
Temperature:		
Low	$T_L$	Lower limit of operating temperature.
Design	$T_D$	Nominal operating temperature.
High	$T_U$	Upper limit of operating temperature.
Degradation Cycle Limit	$N_D$	Number of cycles to the Design Displacement, under the Design Vertical Load, that yields a $\pm 20\%$ change in Effective Stiffness, or a 20% reduction in Energy Dissipation relative to the first complete cycle Effective Stiffness or Energy Dissipation, respectively.
Thermal Cycle Limit	$N_t$	Number of cycles to the Thermal Displacement, under the Design Vertical Load, that yields a $\pm 20\%$ change in Effective Stiffness, or a 20% reduction in Energy Dissipation relative to the first complete cycle Effective Stiffness or Energy Dissipation, respectively.

## **4. GENERAL REQUIREMENTS**

### **4.1 Introduction**

Presented in this chapter are the general requirements for Pre-Qualification, Prototype and Quality Control testing of seismic isolation systems. The topics covered in Sections 4.2 through 4.7 include: test facility, instrumentation and calibration, data acquisition, data analysis, reporting of results and the independent observer. Unless otherwise specified all tests shall be conducted in accordance with the requirements outlined in this chapter. Special requirements are presented, as necessary, in Chapters 5, 6 and 7 in conjunction with particular test specifications. Limited commentary is presented in Section 4.8.

For reference, a schematic diagram of a test specimen under general bi-lateral loading is presented in Figure 4.1. A definition diagram is presented in Figure 4.2. Indicated in the figures are the forces, deformations and elements of the test facility that are referenced in these guidelines.

### **4.2 Test Facility**

Tests shall be conducted in a facility that is capable of applying simultaneously a static vertical load and a cyclic lateral displacement or load to a specimen or group of specimens. The vertical load capacity of the facility shall be at least 10% greater than the largest vertical load to be applied during the test. The test facility shall have a lateral stroke of at least twice the maximum displacement specified for the test, and a lateral load capacity that is at least 10% greater than the largest lateral load to be applied during the test. Tests may be conducted in a single or multiple specimen configuration. The configuration may emulate but is not limited to those illustrated in Figure 4.3.

Unless otherwise specified, the lateral deformation shall be applied under displacement control such that the motion of the actuator is representative of a sinusoidal wave with specified frequency. At frequencies less than 0.004 cyc/sec (periods greater than 4 minutes), the deformation may be applied with constant velocity such that the motion of the actuator is representative of a sawtooth wave with specified frequency. The facility shall be such that the lateral load plane will remain parallel to within  $\pm 5^\circ$  of the bottom and/or top reaction support at all times, for the duration of the test.

The vertical load may be applied under load control or displacement control. Constant vertical loads shall be maintained such that, (1) the average load is within  $\pm 10\%$  of the specified load for the duration of the test, and (2) the maximum and minimum loads are within  $\pm 20\%$  of the specified load for the duration of the test.

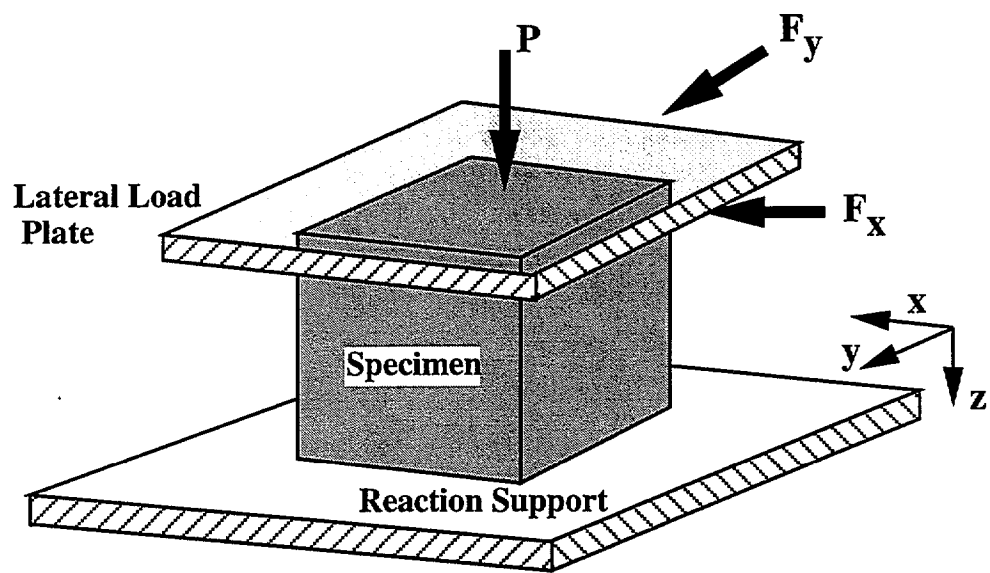

Figure 4.1 Unit or Component Under Bilateral Loading



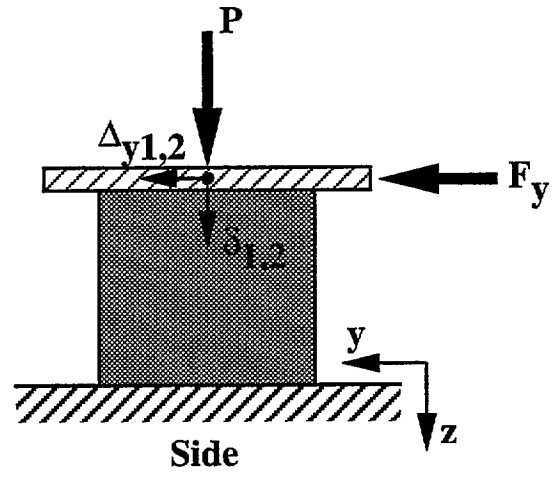
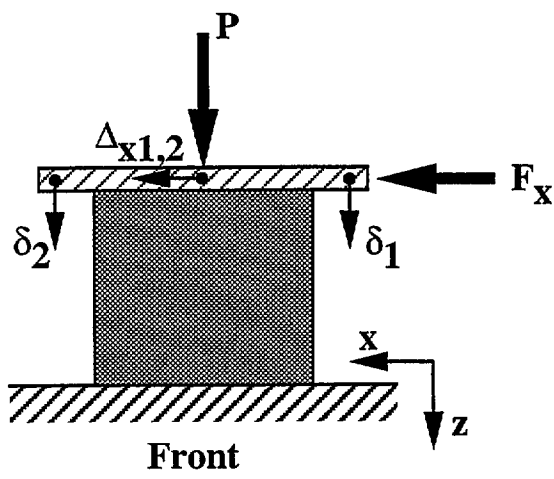
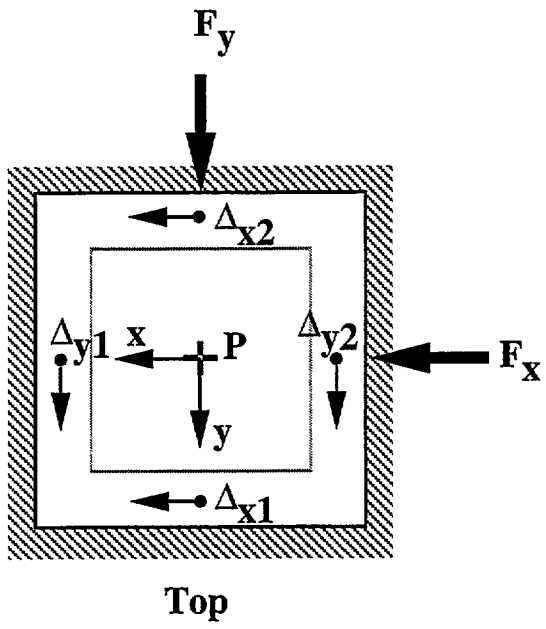

Figure 4.2 Definition Diagram

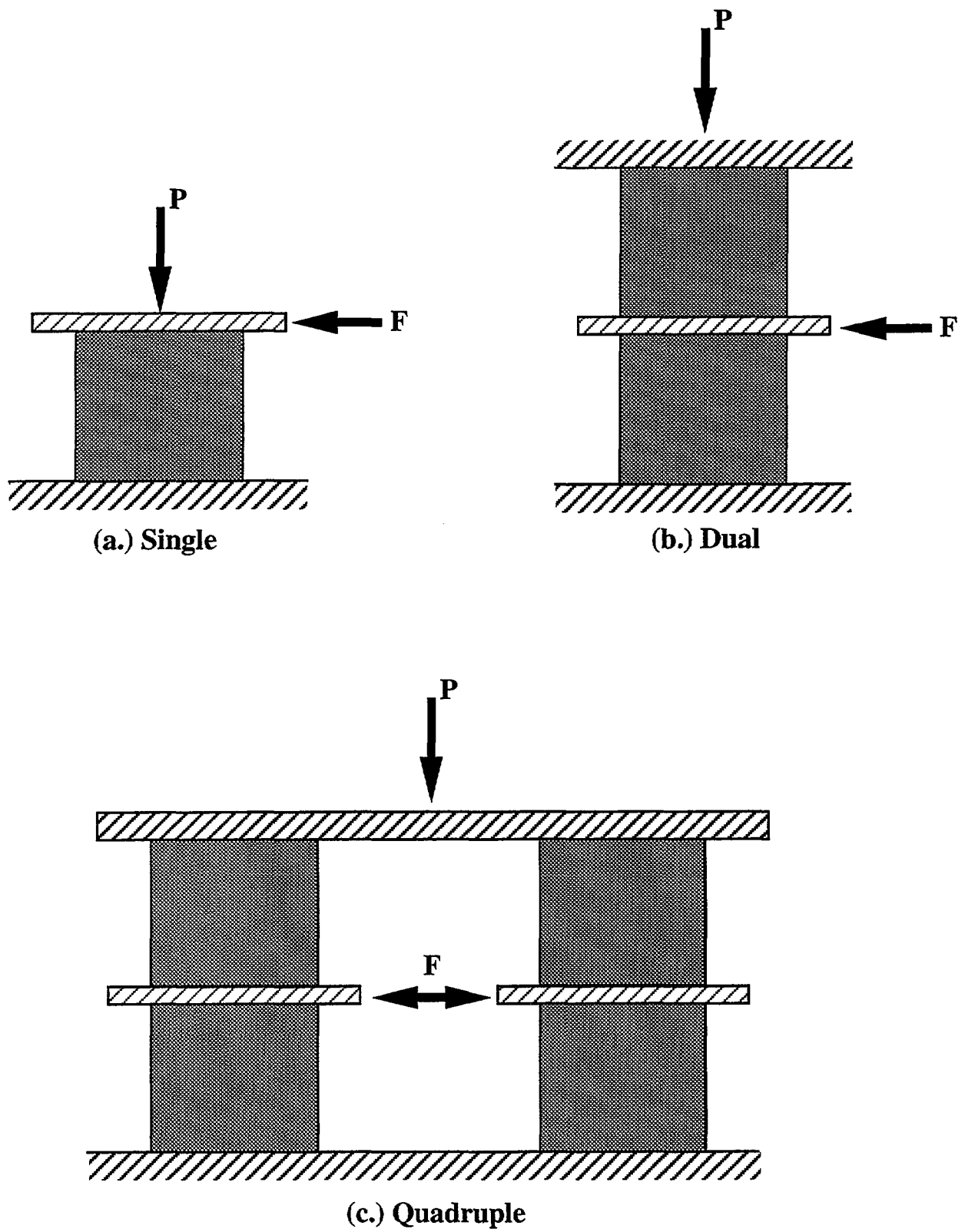

Figure 4.3 Test Configurations

The vertical load system shall be verified in accordance with ASTM E4 to an accuracy<sup>1</sup> of  $\pm 5\%$ . Where possible, the lateral load system shall be verified in accordance with ASTM E4 to an accuracy of  $\pm 2.5\%$ . Otherwise, the lateral load system shall be calibrated<sup>2</sup> as described in ASTM E74 and shall have an uncertainty<sup>3</sup> of not more than  $\pm 2.5\%$  of force. *Load verification or calibration shall be carried out with the actual equipment to be used in the test.* Verification or calibration shall be required after repair or replacement of test facility equipment.

### 4.3 Instrumentation and Calibration

Transducers shall be in place to measure, at a minimum, lateral load, lateral displacement, vertical load and vertical displacement. A thermometer shall be in place to record the temperature of the testing environment.

Loads on the test specimen may be measured via the test machine read-out, load cells in the force train of the actuator or via a force transducer between the specimen and reaction support. Transducers shall be such that loads are resolved to within 1% of the specified full load. Load cells in the force train of the actuator shall be verified or calibrated as outlined in Section 4.2. Other force transducers shall be calibrated periodically as described in ASTM E74 and shall have an uncertainty of not more than  $\pm 2.5\%$  of force.

For frequencies less than 0.004 cyc/sec (periods greater than 4 minutes) load measurements may be made via a calibrated pressure differential across an actuator servo valve. The pressure differential shall be calibrated using a similar procedure as that stated for the load cell or force transducer.

Vertical displacement shall be measured at 2 points on the lateral load plane at opposite sides of the specimen, along a line parallel to the direction of lateral loading ( $\delta_1$  and  $\delta_2$  in Figure 4.2). Lateral displacement shall be measured at 2 points on the lateral load plane, at opposite sides of the specimen, along a line orthogonal to the direction of lateral loading ( $\Delta_{x1}$  and  $\Delta_{x2}$ , or  $\Delta_{y1}$  and  $\Delta_{y2}$  in Figure 4.2). Transducers shall be of sufficient precision to resolve the displacement to within 1% of the specified full displacement. Displacement transducers shall be calibrated periodically and shall have an uncertainty of not more than  $\pm 2.5\%$  of displacement. Suitable displacement transducers include but are not limited to Linear Variable Differential Transformer (LVDT), Direct Current Differential Transformer (DCDT) and Linear Resistance Potentiometer.

---

<sup>1</sup>the specified permissible variation from the correct value, per ASTM E4

<sup>2</sup>the system shall be calibrated using the procedure described in the standard, but not necessarily in accordance with the standard.

<sup>3</sup>a statistical estimate of the limits of error in forces computed from the calibration equation; equal to 2.4 times the standard deviation of the differences between the measured values and the values obtained from the calibration equation; per ASTM E74

#### 4.4 Data Acquisition

An analog or digital data acquisition system shall be used to record time, lateral and vertical loads, two lateral displacements and two vertical displacements, for the duration of the test. Data shall be digitized or sampled at a rate not less than 100 times the frequency of loading. A digital data acquisition system shall be capable of sampling all data channels nearly simultaneously: the maximum time skew between channels shall be less than 1% of the sampling time interval.

#### 4.5 Data Analysis

Data analysis is specified for a typical compression-shear test, assuming  $n$  fully reversed lateral load cycles are completed in the  $x$  direction only. For clarity, subscripts denoting the direction of lateral loading have been dropped. Properties measured or computed that pertain to lateral behavior are for that direction ( $x$ ) only.

Unless otherwise specified the analysis shall include but is not limited to the following. The time history of lateral displacement ( $\Delta$ ) shall be computed as the average of the measured lateral displacements ( $\Delta_1, \Delta_2$ ), i.e.,

$$\Delta(t) = \frac{1}{2}(\Delta_1(t) + \Delta_2(t)) \quad (4.1)$$

The time history of vertical displacement ( $\delta$ ) shall be computed as the average of the measured vertical displacements ( $\delta_1, \delta_2$ ), i.e.,

$$\delta(t) = \frac{1}{2}(\delta_1(t) + \delta_2(t)) \quad (4.2)$$

Hysteresis loops for lateral deformation shall be constructed by plotting the measured lateral load ( $F$ ) versus the lateral displacement ( $\Delta$ ) for the  $n$  cycles of the test. Hysteresis loops for vertical deformation shall be plotted in a similar manner, i.e., vertical load ( $P$ ) is plotted versus vertical displacement ( $\delta$ ) for the  $n$  cycles of the test. Finally, vertical displacement ( $\delta$ ) shall be plotted versus lateral displacement ( $\Delta$ ) for the  $n$  cycles of the test.

##### 4.5.1 Effective Stiffness and Energy Dissipation

The Average Effective Stiffness and Average Energy Dissipation shall be determined for all Isolation Units and Components as described in the following.

The maximum and minimum lateral displacements,  $\Delta_i^+$  and  $\Delta_i^-$  respectively, shall be established for each complete cycle of the test. The maximum and minimum lateral loads,  $F_i^+$  and  $F_i^-$  respectively, shall be established for each cycle of the test. Effective Stiffness ( $K_{H_i}$ ) for each complete cycle  $i$  shall be computed as follows,

$$K_{H_i} = \frac{F_i^+ - F_i^-}{\Delta_i^+ - \Delta_i^-} \quad (4.3)$$

The Average Effective Stiffness ( $K_H$ ) shall be computed for the  $n$  cycles of the test, as given by

$$K_H = \frac{1}{n} \sum_1^n K_{H_i} \quad (4.4)$$

Energy Dissipation shall be determined for each complete cycle of the test. The energy dissipated in cycle  $i$  ( $E_{H_i}$ ), is equal to the area enclosed by the hysteresis loop for that cycle and should be expressed in units of force-length (e.g., kN-mm, or kip-in, etc.). The area enclosed by the loop may be determined by numerical integration for digital data, or by other suitable means for analog data. The Average Energy Dissipation ( $E_H$ ) shall be determined for the  $n$  cycles of the test, as given by

$$E_H = \frac{1}{n} \sum_1^n E_{H_i} \quad (4.5)$$

#### 4.5.2 Static and Kinetic Coefficients of Friction

The Static Coefficient of Friction and the Average Kinetic Coefficient of Friction shall be determined as described in the following, for Isolation Units that exhibit an elastic- or rigid-perfectly plastic hysteretic behavior.

The "break-away" force ( $F_s$ ), defined as the minimum force required to initiate relative movement across the sliding interface, shall be established from the first quarter cycle of the recorded load-deflection data. The Static Coefficient of Friction shall be computed as the ratio of the break-away force to vertical load, i.e.,

$$\mu_s = \frac{|F_s|}{|P_s|} \quad (4.6)$$

where  $P_s$  is the measured vertical load corresponding to  $F_s$ .

The average lateral load ( $F_{AVE}$ ) and the average vertical load ( $P_{AVE}$ ) shall be determined for each of the  $2n-1$  complete half cycles of loading, in the range of displacements  $-0.9D$  to  $0.9D$ . The Kinetic Coefficient of Friction shall be computed for half cycle  $i$  as the ratio of average lateral load to average vertical load, i.e.,

$$\mu_{k_i} = \frac{|F_{AVE}|}{|P_{AVE}|} \quad (4.7)$$

The Average Kinetic Coefficient of Friction ( $\mu_k$ ) shall be computed for the  $2n-1$  complete half cycles of loading, as given by

$$\mu_k = \frac{1}{2n-1} \sum_1^{2n-1} \mu_{k_i} \quad (4.8)$$

## 4.6 Report of Results

Results of the tests shall be documented in a clear and concise report. Unless otherwise specified the report should include but is not limited to the following:

### (a.) General

1. Title and test designation.
2. Date and time of the start of the test.
3. Laboratory or institution conducting the test.
4. Name of the person responsible for the test.
5. Name of the persons observing the test.

### (b.) Test Setup

1. Specimen identification
2. Specimen scale (full or some fraction thereof).
3. Test configuration (single, dual, quadruple or other).
4. Sketch of the test setup, with load and displacement transducer positions indicated.
5. Temperature of the test environment.
6. Test parameters: number of cycles, displacement  $D$ , frequency of loading, vertical load, and temperature of the specimen.

### (c.) Results

1. Effective Stiffness for each complete cycle, listed by cycle number in increasing order.
2. Energy Dissipation for each complete cycle, listed by cycle number in increasing order.
3. Average Effective Stiffness for the  $n$  cycles of the test.
4. Average Energy Dissipation for the  $n$  cycles of the test.
5. Calculation of criteria associated with the test.
6. Hysteresis plots of:
  - lateral load versus lateral deflection
  - vertical load versus vertical deflection
  - vertical deflection versus lateral deflection.

## 4.7 Independent Observer

An independent, third party observer shall be present during all testing. The observer shall be experienced and knowledgeable in testing and should be familiar with the guideline test procedures. The role of the observer shall be to observe the tests and note any deviations or noncompliance with the guidelines.

## 4.8 Commentary

### *C4.1 Introduction.*

The test procedures outlined in the Guidelines can generally be classified as either "compression/shear" or "cyclic lateral load" tests, or "ultimate or reserve capacity" tests. A compression/shear test requires applying simultaneously a constant vertical load and a cyclic lateral displacement to a test specimen. The test is conducted for a specified vertical load, maximum lateral displacement, number of cycles and frequency of loading. An ultimate capacity test requires applying a monotonically increasing load until failure is observed, as indicated by overstress, buckling, fracture, rupture, or other event. The ultimate capacity test is conducted for load in the vertical or lateral plane, and may also require imposing a static load or displacement in a direction that is not coincident with the primary load direction. A reserve capacity test is similar to the ultimate test, except that the specimen is not taken to failure; the test continues until a load is reached that is over and above some specified nominal value. The majority of tests specified in Chapters 5, 6 and 7 can be classified as compression/shear tests and have similar equipment and data analysis requirements; therefore, rather than duplicate material, general requirements are outlined in this chapter and exceptions or special requirements for a particular test are noted in the later chapters.

### *C4.2 Test Facility.*

As a minimum the test facility must be capable of subjecting a specimen to combined compression/shear. In a few tests the specimen is sheared laterally in two orthogonal directions, in which case, the facility must apply a bilateral shear load, as illustrated in Figure 4.1. For a specified vertical load and lateral displacement the most convenient control system combination is, vertical under load- and lateral under displacement-control.

Historically, isolation Units have been tested in the single, dual or quadruple configurations, as illustrated in Figure 4.3. The three configurations have certain advantages and disadvantages that offer trade-offs between complexity of the test facility and uniqueness of the experimental data:

- In the single specimen configuration the bottom of the specimen is held fixed and the top is sheared laterally (Figure 4.3a), or visa-versa. Single specimens may also be tested by shearing both top and bottom planes in alternating directions (see Figure C.4 in Appendix C). The data obtained in the single specimen configuration is unique to that specimen; however, the test set-up is the most complex of the three because both lateral load and moment reaction supports must be provided by the test facility.
- In the dual configuration the lateral load is applied to a plate that is sandwiched between two specimens, the other ends of which are held fixed (Figure 4.3b). A disadvantage of the dual configuration, or any multiple specimen configuration, is that results obtained are the average of the two or more specimens being tested (unless special arrangements are made to measure, independently, the forces on the individual specimens).
- In the quadruple configuration four specimens are tested in stacks of two, with the lateral load applied between the stacks (Figure 4.3c). The data obtained in the quadruple configuration is the average of four specimens; however, the test set-up is the simplest

of the three since it is completely self-equilibrating. This eliminates the need for both the moment and lateral load reaction supports.

Of the six facilities illustrated in Appendix C, five test in a single specimen configuration and one uses a dual configuration.

It is important that the test facility and equipment be periodically verified or calibrated. Verification refers to establishing the accuracy of a test machine or facility over a specified load range, using a load measuring device that is traceable to NIST, i.e., a secondary standard. ASTM E4 addresses load verification, but is intended for ordinary laboratory universal testing machines. At the present time, a national standard does not exist for load verification of tension/compression/shear test facilities.

ASTM E4 may be applied to the vertical load system, independent of the lateral, if interaction between the two systems is assumed or shown to be negligible. ASTM E4 may also be used for the lateral system, independent of the vertical, however, the following problems may be encountered: (1) it may require the fabrication of special fixtures to load a uniaxial secondary standard using the lateral system, (2) the system must be verified under load and not displacement control. An alternative is to calibrate the lateral system using the procedure described in ASTM E74. Calibration refers to determining the calibration factor and uncertainty of an instrumentation package: the calibration factor is subsequently used to convert an analog output to engineering units. Note that it is not necessary to conform to ASTM E74, since the standard is actually intended for calibration of primary and secondary standards used in ASTM E4, however, the approach is applicable to other instruments and is easily followed. Note, the actual equipment "package" to be used in the test should be calibrated. At a minimum this would include the load cell and data acquisition system. Calibration of the complete test package, however, is highly recommended. This would include servo-valve, actuator, load cell and data acquisition system.

#### *C4.3 Instrumentation and Calibration.*

Vertical loads are typically measured via the test machine read-out in facilities that use a universal test machine or press to apply the axial load. Otherwise, loads (vertical and lateral) are measured via a load cell in the actuator train, or by a force transducer located directly beneath the specimen. A load cell in the actuator train is suitable provided dynamic effects of the test facility are negligible, i.e., the measured load *is equal to* the load on the specimen. As an alternative, or for verification, loads can be measured via a transducer between the specimen and reaction frame. In either case, care should be taken to ensure that the frequency response characteristics of the load cell or transducer are properly matched to the test conditions, particularly for higher frequencies of loading. Transducers should be calibrated periodically using an appropriate procedure. If the transducer is sensitive to combined shear, axial and moment load conditions, the calibration procedure should take this into account.

At loading frequencies less than 0.004 cyc/sec (periods greater than 4 minutes), i.e., pseudo-static loading, the load can be measured via a calibrated pressure differential across the actuator servo valve. This eliminates the need for a load cell in the actuator train. This is not, however, an



accurate or reliable technique for dynamic testing and should not be used at actuator velocities greater than that stated.

In a cyclic bilateral load test a minimum of six displacement measurements are required: 2 vertical displacements and 2 lateral displacements in each of the orthogonal directions (see Figures 4.1 and 4.2). Two measurements are required on opposite sides of the specimen in each direction. Mechanical dial gages are not recommended, except as back-up or for quick reference while the test is being conducted.

Displacement transducers should be calibrated periodically using an appropriate procedure. The procedure should include, at a minimum, 3 measurements at 5 displaced positions within the stroke range to be used during testing. The true displaced position should be established using a stable measuring instrument that has a resolution at least an order of magnitude smaller than the device being calibrated. A linear or second order curve should be fit to the data using a least squares technique and the uncertainty of the fit established. Once again, proper calibration involves the complete transducer "package" to be used during testing. This includes transducer, signal conditioning equipment, power supply and data acquisition system.

The uncertainty to be permitted in the measured Effective Stiffness and Energy Dissipation dictates the uncertainty allowed of the load cells and displacement transducers. Noting Eq. (4.3), Effective Stiffness is a ratio that involves four independently measured quantities. It can be shown that the uncertainty in  $K_{H_i}$  may be estimated by the square-root, sum-of-squares of the uncertainties of each of the measured quantities, i.e.,

$$U_K = \left\{ U_{F^+}^2 + U_{F^-}^2 + U_{\Delta^+}^2 + U_{\Delta^-}^2 \right\}^{1/2} \quad (4.6)$$

in which  $U_{(\ )}$  denotes the uncertainty of the measured values. Assuming the desired uncertainty in measured Effective Stiffness is  $\pm 5.0\%$ , force and displacement must be measured with an uncertainty of  $\pm 2.5\%$ . A similar result is obtained for the calculation of Energy Dissipation.

#### *C4.4 Data Acquisition.*

Data is to be recorded with an analog or digital data acquisition system. Although digital data acquisition systems are becoming the norm, analog devices are still in use. For ease of subsequent computer analysis, data recorded using an analog device is often digitized from the analog record. In either case it is important to digitize or sample test data at a rate that will accurately resolve the load-deformation hysteresis loop. A rate of 100 times the frequency of loading (e.g., 50 samples/sec for a frequency of loading of 0.5 cyc/sec) will resolve a typical hysteresis loop into approximately 100 data points. This is a recommended minimum: a higher sampling rate may be required to accurately resolve loops with sharp peaks, and to get an accurate measure of Effective Stiffness and Energy Dissipation.

#### C4.5 Data Analysis.

The analysis of data from a cyclic lateral load test involves, at a minimum, (1) construction of hysteresis loops, (2) determination of the Average Effective Stiffness and, (3) determination of the Average Energy Dissipation. For a quick qualitative evaluation of the general strength and stiffness characteristics of the Isolation Unit or Component, a hysteresis plot is most valuable. A few examples of measured hysteresis loops are presented in Figure 4.4.

The key parameters derived from the experimental data are Average Effective Stiffness and Average Energy Dissipation. These parameters characterize the Isolation System and, in design, determine the magnitude of lateral load transmitted to the superstructure. The Effective Stiffness of a cycle is the difference in maximum and minimum forces divided by the difference in maximum and minimum displacements, as given by Eq.(4.3). Energy Dissipation is the area enclosed by the loop. These are illustrated in Figure 4.5 for a hypothetical hysteresis loop. Effective Stiffness and Energy Dissipation should only be determined for *complete* cycles of loading. Data from the first half cycle and the last half cycle should not be used in the determination of the system properties.

In the past, the energy dissipated by a structural element, connection or Isolation Unit under cyclic loading has been reported in terms of an equivalent viscous damping ratio ( $\xi_e$ ), which is given by (Chopra, 1995)

$$\xi_e = \frac{1}{4\pi} \frac{E_H}{E_S} \quad \text{where} \quad E_S = \frac{1}{2} K \Delta^2 \quad (4.10)$$

where  $E_H$  is the energy dissipated by the specimen (i.e., the area enclosed by the hysteresis loop),  $E_S$  is the elastic strain energy of the member,  $K$  is the stiffness and  $\Delta$  is the displacement. Viscous damping has been reported, even if the energy dissipation mechanism is not of a viscous type (e.g., is of a hysteretic or friction type), because it is the simplest form of damping to use in a theoretical analysis. Reporting energy dissipation in terms of  $\xi_e$ , however, can make the comparison of the dissipative capacity of two different systems more difficult since the stiffness enters into the calculation. Therefore, throughout the guidelines, the dissipative capacity of a Unit or Component is reported in terms of energy dissipation, i.e., the area enclosed by the hysteresis loop. This form will make for direct comparison of different systems more straight forward.

For many Units and Components Effective Stiffness represents the slope of the line that connects the points of maximum force (displacement) and minimum force (displacement), as illustrated in Figure 4.5. The stiffness calculation in this case is intuitively obvious. In some cases, however, the maximum (minimum) force and maximum (minimum) displacement in a cycle *are not coincident*. This tends to occur when hysteresis loops are very rounded: examples of this type are illustrated in Figure 4.6. In this case, Effective Stiffness computed according to equation (4.3) is some average measure of the force-deflection behavior. For loops such as that shown in Figure 4.6, more elaborate analysis may be required; for example, by calculating two stiffnesses for each cycle, i.e., the effective stiffness that corresponds to the line connecting the maximum and

minimum forces, and the effective stiffness that corresponds to the line connecting the maximum and minimum displacements.

Some components, e.g., pure sliding devices, will exhibit an elastic-perfectly plastic, or rigid-perfectly plastic hysteretic load-deflection behavior. An example of elastic-perfectly plastic behavior is shown in Figure 4.7. The Average Effective Stiffness and Average Energy Dissipation can be measured for this type of system; however, in addition to that, the Static Coefficient of Friction and Average Kinetic Coefficient of Friction should be evaluated.

*C4.6 Report of Results.*

None.

*C4.7 Independent Observer.*

None.

Vmax = 10.971 kips  
Vmin = -10.088 kips  
Dmax = 2.934 inches  
Dmin = -3 inches

Axial Load = 31.455 kips  
Strain = 100.007 %

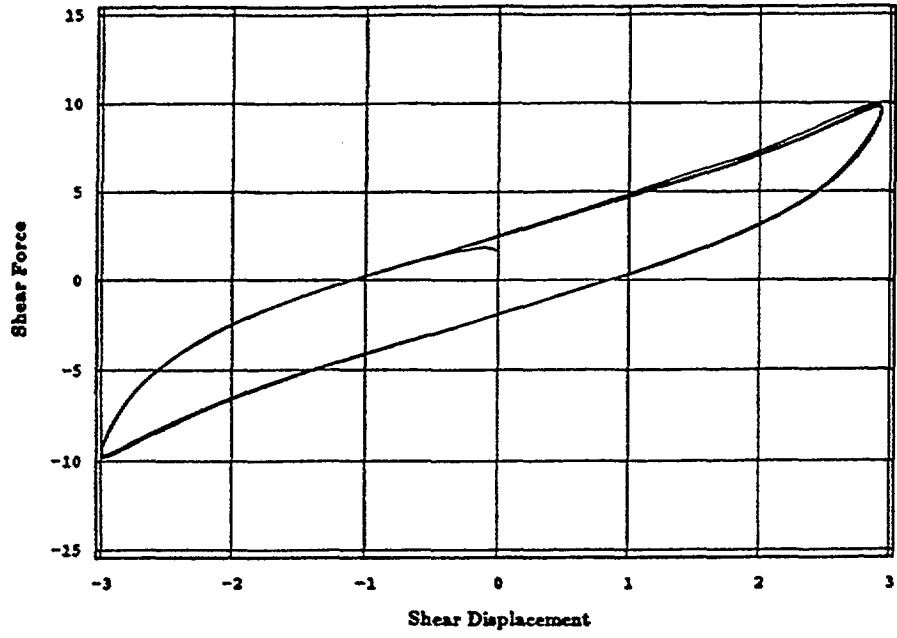

(a.) Laminated Elastomeric Bearing (Aiken, Kelly, Tajirian 1989)

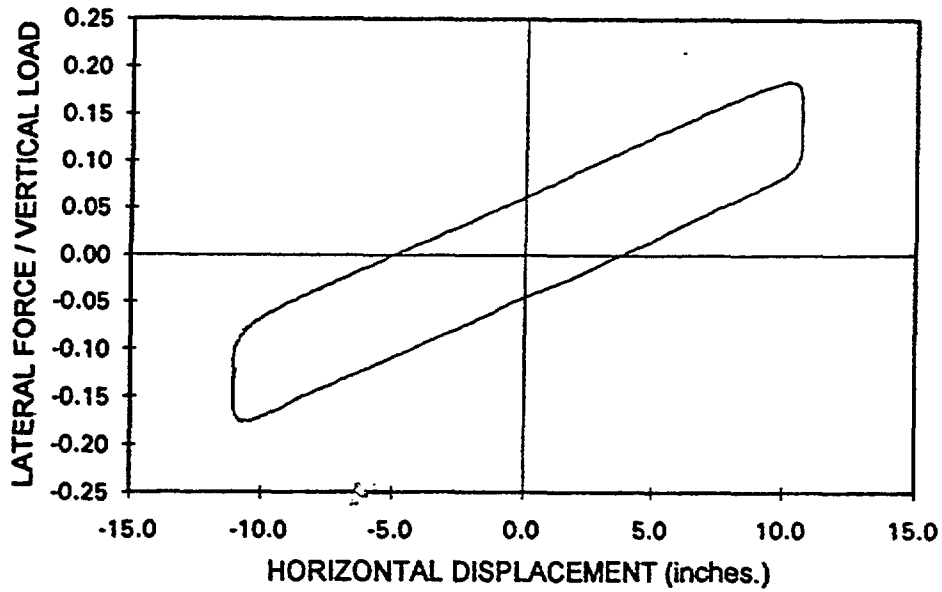

(b.) Friction Pendulum System (Zayas, et al 1990)

Figure 4.4 Sample hysteresis loops

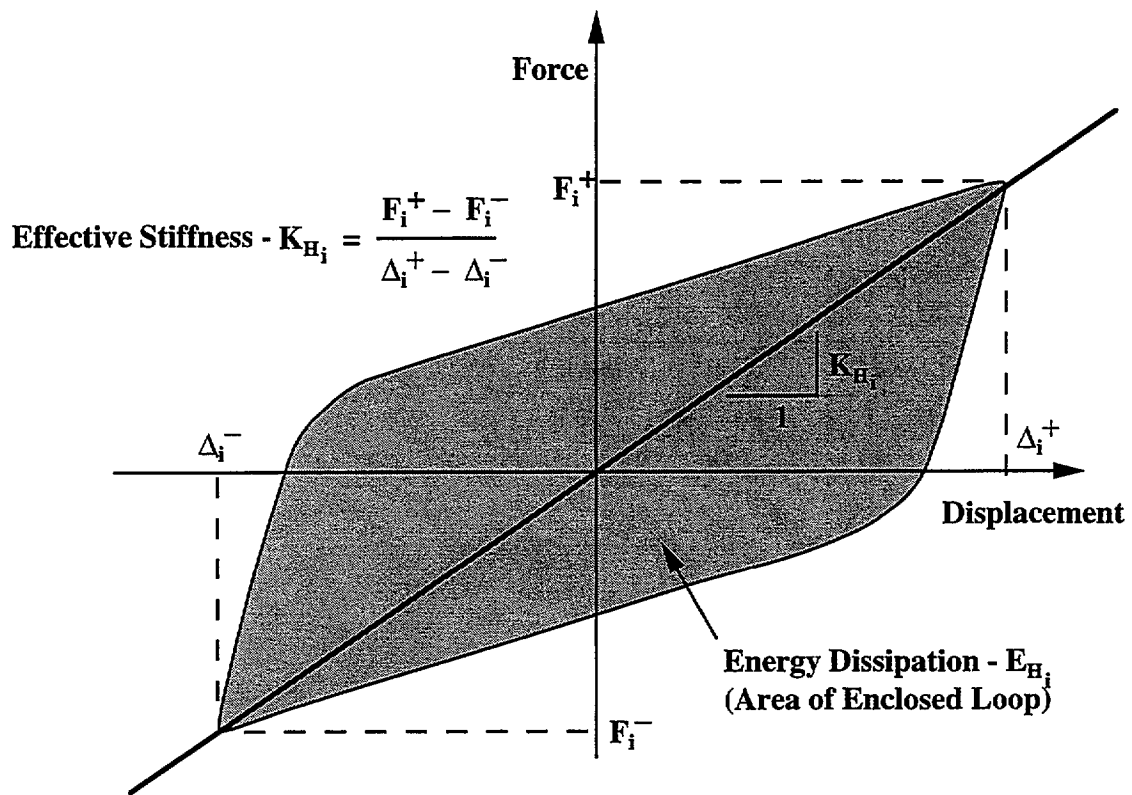

Figure 4.5 Effective Stiffness and Energy Dissipation for Typical Hysteresis Loop

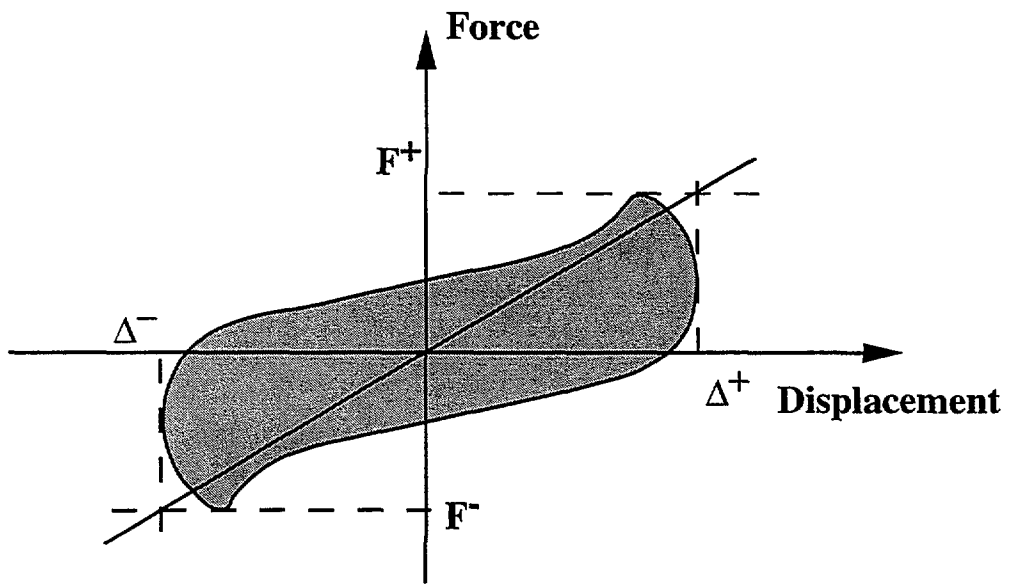
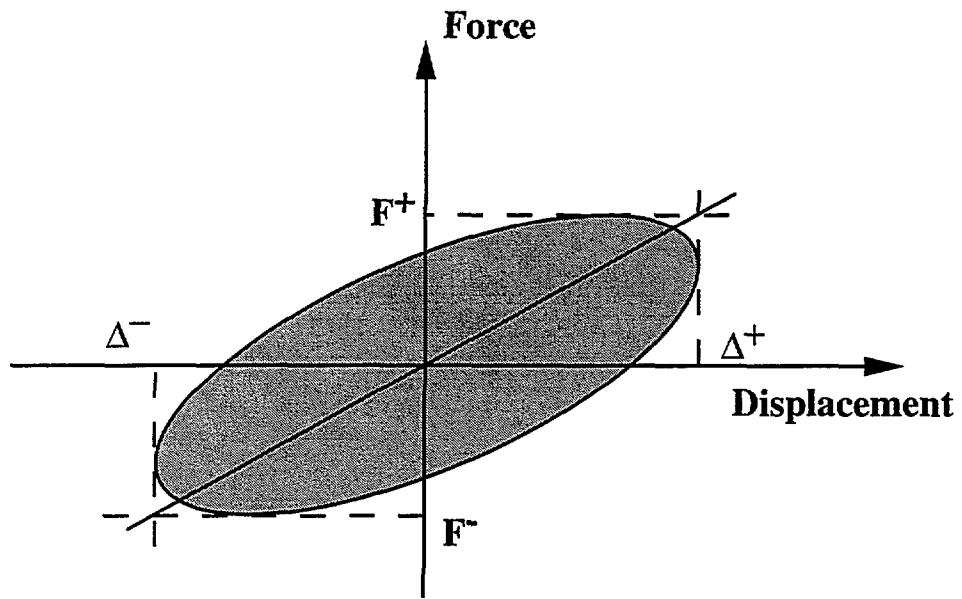

Figure 4.6 Effective Stiffness as Measured in Various Loops

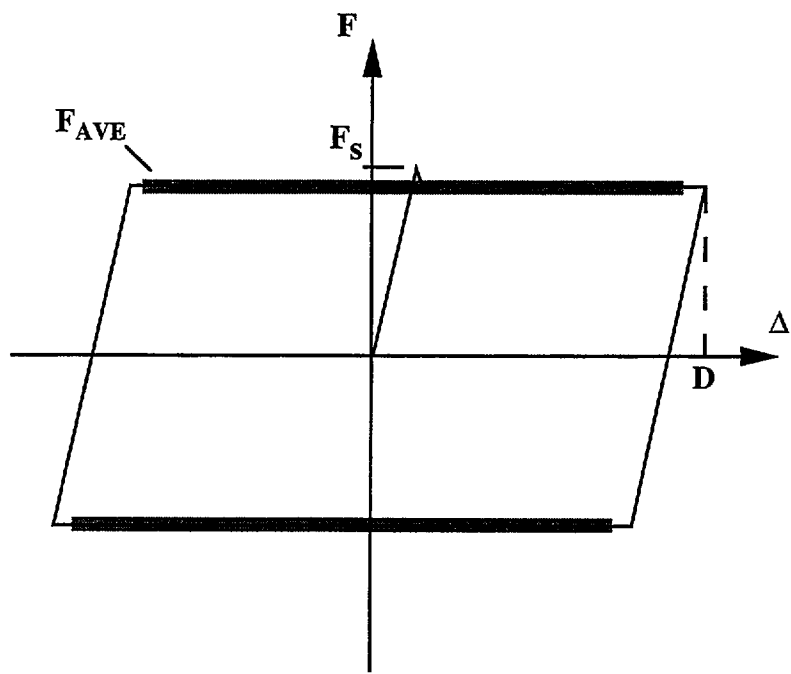

Figure 4.7. Elastic-Perfectly Plastic Hysteretic Behavior





## 5. PRE-QUALIFICATION TESTS

### 5.1 Introduction

Pre-Qualification tests need not be project specific and are conducted in order to establish the fundamental properties and characteristics of the isolation system, and to determine the extent to which these properties are dependent on load and environmental factors. This chapter outlines the requirements for pre-qualification testing.

Pre-qualification includes all tests in Categories I through V. This includes Categories I (Preliminary Characterization) and II (Ultimate and Reserve Capacity) of this chapter, as well as a complete series of prototype tests (Categories III and IV, Chapter 6) and quality control tests (Category V, Chapter 7).

The purpose of the Preliminary Characterization series is to establish the effect of various factors on the system response. In these tests the Average Effective Stiffness and Average Energy Dissipation are evaluated for a limited range of displacements under varying load and environmental conditions. Tests are conducted to determine the effect of virgin loading, frequency of load, vertical load, load direction, load plane rotation, bilateral load, temperature, creep, aging, load cycling, load cycle history, and to establish the System's re-centering capability.

The purpose of the Ultimate and Reserve Capacity series is to establish the ultimate capacity, or demonstrate reserve capacity, of the System, Unit or Component under various load conditions. The tests include ultimate compression under zero lateral load, compression in the displaced position, ultimate tension under zero lateral load, tension in the displaced position, and lateral load and displacement capacity under the design vertical load. Tests denoted as "ultimate" are proof tests and are conducted to failure.

Performance criteria have been established for all tests in Categories II through V. The criteria are measures against which the performance of the isolation system or component is tested: systems that do not meet these minimum criteria may not perform adequately in service. Most of the criteria are in the form of simple expressions that are to be evaluated based on the results of the test. Others are descriptive in nature and require a subjective evaluation of test results. For most tests two criteria are specified, one in terms of the Average Effective Stiffness and another in terms of the Average Energy Dissipation. Both must be fulfilled to satisfy the overall test criteria.

Performance criteria have not been specified for the Category I tests. Instead, special requirements are outlined for calculating and reporting results that quantify the effect of certain factors on the system response.

Test procedures are presented in a standard format that includes the following elements:

*Test*

*Designation:* Tests are designated using the notation "C.#", where C denotes the category in Roman numerals and # denotes the test number. For example, II.2 refers to test number 2 of Category II.

- Purpose:* A brief statement of the purpose of the test.
- Sequence:* Test parameters and the sequence are specified (e.g., number of cycles, loads, rates, etc).
- Procedure:* A narrative description of the procedure for conducting the test.
- Criteria:* Performance criteria described previously.
- Special Requirements:* Other requirements or exceptions to those presented in Chapter 4.
- Exception:* In certain cases exceptions to the recommended procedure are allowed.

General requirements are discussed in Section 5.2. Guidelines for conducting Preliminary Characterization tests (Category I) are presented in Section 5.3. Guidelines for conducting Ultimate and Reserve Capacity tests (Category II) tests are presented in Section 5.4. Limited commentary for the Category I and II tests is presented in Section 5.5.

## 5.2 General Requirements of Pre-Qualification Tests

Unless otherwise specified Pre-qualification tests shall be conducted in accordance with the following:

- (a) Pre-qualification shall include all tests outlined in Table 5.1, a complete series of prototype tests (Chapter 6, Table 6.1), and applicable quality control tests (Chapter 7, Tables 7.1 or 7.2).
- (b) Tests shall be conducted on Isolation Units and Components. Components may be tested individually, or in combination with other Units and Components in the Isolation System provided the assembly tested is representative of the full system detail. Connections between the specimen and test facility shall be representative of the field connection. It may be necessary to substantiate, either theoretically or by additional tests, the overall behavior and stability of the Isolation System when the tests described herein are conducted only on individual Components.
- (c) Tests shall be performed separately on a minimum of two replicate specimens of the same Isolation Unit or Component. A sufficient number of specimens shall be used such that two independent data sets are obtained when testing in a multiple specimen configuration. Specimens are to be new and previously never tested. The same specimens shall be used for the entire series of tests: a new specimen may be substituted for a damaged one in the pre-qualification series, provided this is noted in the report ("damaged" refers to a specimen that has been altered by earlier tests to such an extent that it could not perform one or more of its primary functions, as originally designed).
- (d) All tests shall be conducted on full scale specimens, unless otherwise specified. In certain instances, scale model specimens are acceptable for Category I tests, provided they are not less than 1/4 full scale and are representative of the full scale prototype.

*Note - it is recognized that facilities do not yet exist to test full size Units or Components under some of the conditions outlined in the guidelines, because of the size and load carrying capacity of the specimen. In this case scale model specimens are acceptable.*

- (e) The nominal capacity of the specimen to be tested must be rated by the supplier prior to testing. Properties to be rated are presented in chapter 3.
- (f) Unless otherwise specified the frequency of isolation ( $f_i$ ) (i.e., inverse of the isolated period  $f_i = 1/T_i$ ) shall be determined from the rated Horizontal Stiffness ( $K_H$ ) and the Design Vertical Load ( $P_D$ ).
- (g) Category I tests shall be conducted in the order in which they are listed in the Guidelines.

- (h) Properly documented Pre-qualification tests previously conducted on a Unit or Component may be used to satisfy the requirements of this section, provided the Unit or Component to be tested is similar in design, materials and construction as that tested previously.

Table 5.1. Schedule of Pre-Qualification Tests<sup>1</sup>

Category	Designation	Test
I	I.1	Establish effect of virgin loading
	I.2	Establish effect of frequency of load
	I.3	Establish effect of vertical load
	I.4	Establish effect of load direction
	I.5	Establish effect of load plane rotation
	I.6	Establish effect of bilateral load
	I.7	Establish effect of temperature
	I.8	Establish effect of creep
	I.9	Establish effect of aging
	I.10	Establish effect of load cycling
	I.11	Establish effect of load cycle history
	I.12	Establish re-centering capability
II	II.1	Ultimate compression under zero lateral load
	II.2	Compression in displaced position
	II.3	Ultimate Tension under zero lateral load
	II.4	Tension in displaced position
	II.5	Lateral load and displacement capacity under design vertical load

<sup>1</sup>Pre-qualification shall also include a complete series of prototype tests (chapter 6) and quality control tests (chapter 7).

### 5.3 Category I - Preliminary Characterization

#### 5.3.1 Test for effect of virgin loading.

*Test*

*Designation:* I.1

*Purpose:* To establish the virgin loading response and its affect on the response in subsequent cycles.

*Sequence:* Denoting two specimens as "A" and "B", tests shall be conducted in accordance with the following:

(a.) *Specimen A only* - 5 fully reversed cycles to a peak displacement of  $\pm D$ ;

(b.) *Specimens A and B* - 3 fully reversed cycles at each of the displacement increments  $\pm 0.25D$ ,  $\pm 0.5D$ ,  $\pm 0.75D$  and  $\pm 1.0D$ .

Tests shall be conducted in the order listed, with a vertical load equal to  $P_D$ , a specimen temperature of  $T_D$ , and at a frequency of loading of not less than 0.004 cyc/sec.

*Procedure:* Place the specimen in the test machine and secure to the supports and loading plate. Apply the full vertical load to the specimen and allow the load to stabilize. Subject the specimen to the required number of fully reversed cycles of lateral deformation. The test shall be run continuously without pause between cycles, or without pause between changes in displacement increments in (b). Sufficient time shall be allowed between sequences (a) and (b) to dissipate any heat developed during the previous test.

*Criteria:* None

*Special*

*Requirements:* Report of results: The report shall include the following:

(1.) the Average Effective Stiffness and Average Energy Dissipation of specimen A for test sequence (a);

(2.) the Average Effective Stiffness of specimens A and B at each increment of displacement in test sequence (b), and the percent difference, as given by

$$\frac{|K_H^A - K_H^B|}{\{K_H^A, K_H^B\}_{\min}} \times 100 \quad (5.1)$$

where  $K_H^A$  is the Average Effective Stiffness at a given displacement increment of specimen A,  $K_H^B$  is the Average Effective Stiffness at the same displacement increment of specimen B, and  $\{K_H^A, K_H^B\}_{\min}$  denotes the minimum of  $K_H^A$  and  $K_H^B$ ;

(3.) the Average Energy Dissipation of specimens A and B at each increment of displacement in test sequence (b), and the percent difference, as given by

$$\frac{|E_H^A - E_H^B|}{\{E_H^A, E_H^B\}_{\min}} \times 100 \quad (5.2)$$

where  $E_H^A$  is the Average Energy Dissipation at a given displacement increment of specimen A,  $E_H^B$  is the Average Energy Dissipation at the same displacement increment of specimen B, and  $\{E_H^A, E_H^B\}_{\min}$  denotes the minimum of  $E_H^A$  and  $E_H^B$ .

### 5.3.2 Test for effect of frequency of loading.

#### Test

**Designation:** I.2

**Purpose:** To establish the effect frequency of loading on the system response and to determine the lower ( $f_L$ ) and upper ( $f_U$ ) threshold frequencies.

*The lower threshold frequency is defined as that frequency, which is less than  $f_b$ , at which either the Average Effective Stiffness or the Average Energy Dissipation of the specimen differs by 10% from the Average Effective Stiffness or Average Energy Dissipation of the specimen, measured at a frequency of  $f_i$ .*

*The upper threshold frequency is defined as that frequency, which is greater than  $f_b$ , at which either the Average Effective Stiffness or the Average Energy Dissipation of the specimen differs by 10% from the Average Effective Stiffness or Average Energy Dissipation of the specimen, measured at a frequency of  $f_i$ .*

**Sequence:** (a.) 3 fully reversed cycles to peak displacements of  $\pm D$  at a frequency corresponding to  $f_i$  (the isolation frequency).  
(b.) 3 fully reversed cycles to peak displacements of  $\pm D$ , at increments of increasing frequency between 0.004 cyc/sec and  $2f_i$ , as needed, to determine the lower and upper threshold frequencies. The test shall include a series of three cycles at a frequency of  $f_i/2$  and a series of three cycles at a frequency of  $3f_i/2$ . Tests shall be conducted with a vertical load equal to  $P_D$  and at a specimen temperature of  $T_D$ .

**Procedure:** Sequence (a.): Place the specimen in the test machine and secure to the supports and loading plate. Apply the full vertical load to the specimen and allow the load to stabilize. Subject the specimen to the required 3 fully reversed cycles of lateral deformation, without pause between cycles.

Sequence (b): Same as sequence (a); the frequency of loading shall be increased in increments until the lower and upper threshold frequencies are established as described below in *Report of Results*.

Sufficient time shall be allowed between tests at the different rates to dissipate any heat developed during the previous test. The vertical load shall be maintained between tests.

**Criteria:** None

#### Special

**Requirements:** Reporting of Results: The report shall include the following:

(1.) the Average Effective Stiffness and Average Energy Dissipation for test sequence (a).

(2.) the Average Effective Stiffness at each of the frequency increments in test sequence (b), in order of increasing frequency; report the percent difference relative to the Average Effective Stiffness at the isolation frequency, as given by



$$\frac{|K_H^f - K_H|}{K_H} \times 100 \quad (5.3)$$

where  $K_H$  is the Average Effective Stiffness measured in test sequence (a) at a frequency of  $f_i$ , and  $K_H^f$  is the Average Effective Stiffness measured at a frequency of  $f$  in test sequence (b).

(3.) the Average Energy Dissipation at each of the frequency increments in test sequence (b), in order of increasing frequency; report the percent difference relative to the Average Energy Dissipation at the isolation frequency, as given by

$$\frac{|E_H^f - E_H|}{E_H} \times 100 \quad (5.4)$$

where  $E_H$  is the Average Energy Dissipation measured in test sequence (a) at a frequency of  $f_i$ , and  $E_H^f$  is the Average Energy Dissipation measured at a frequency of  $f$  in test sequence (b).

(4.) the lower threshold frequency ( $f_L$ ), is the maximum frequency that is less than  $f_i$ , that corresponds to a  $\pm 10\%$  change in Average Effective Stiffness, or a  $\pm 10\%$  change in Average Energy Dissipation, relative to the stiffness and energy dissipation measured at  $f_i$ , as given by equations (5.3) and (5.4).

(5.) the upper threshold frequency ( $f_U$ ), is the minimum frequency that is greater than  $f_i$ , that corresponds to a  $\pm 10\%$  change in Average Effective Stiffness, or a  $\pm 10\%$  change in Average Energy Dissipation, relative to the stiffness and energy dissipation measured at  $f_i$ , as given by equations (5.3) and (5.4).

### 5.3.3 Test for effect of vertical load.

#### Test

*Designation:* I.3

*Purpose:* To establish the effect of vertical load on the system response.

*Sequence:* Three (3) fully reversed cycles to peak displacements of  $\pm D$ . Tests shall be conducted for vertical loads corresponding to  $P_L$ ,  $P_D$ , and  $P_U$ . Tests shall be conducted with a specimen temperature of  $T_D$ , and at a frequency of loading of not less than  $f_L$  or 0.004 cyc/sec.

*Procedure:* Place the specimen in the test machine and secure to the supports and loading plate. Apply the full vertical load to the specimen and allow the load to stabilize. Subject the specimen to the required 3 fully reversed cycles of lateral deformation. Remove the vertical load. The test shall be run continuously without pause between cycles. Repeat for the next vertical load. The tests shall be conducted at the vertical loads specified in the order  $P_L$ ,  $P_D$  and  $P_U$ . Sufficient time shall be allowed between tests at the different vertical loads to dissipate any heat developed during the previous test.

*Criteria:* None

#### Special

*Requirements:* Report of Results: The report shall include the following:

(1.) the Average Effective Stiffness at vertical loads corresponding to  $P_L$ ,  $P_D$ , and  $P_U$ , and the percent difference relative to the Average Effective Stiffness at a load of  $P_D$ , as given by

$$\frac{|K_H^{P_L} - K_H|}{K_H} \times 100 \quad \text{and} \quad \frac{|K_H^{P_U} - K_H|}{K_H} \times 100 \quad (5.5)$$

where  $K_H$  is the reference Average Effective Stiffness measured at a vertical load corresponding to  $P_D$ ,  $K_H^{P_L}$  is the Average Effective Stiffness measured at a vertical load corresponding to  $P_L$ , and  $K_H^{P_U}$  is the Average Effective Stiffness measured at a vertical load corresponding to  $P_U$ .

(2.) the Average Energy Dissipation at vertical loads corresponding to  $P_L$ ,  $P_D$ , and  $P_U$ , and the percent difference relative to the Average Energy Dissipation at a load of  $P_D$ , as given by

$$\frac{|E_H^{P_L} - E_H|}{E_H} \times 100 \quad \text{and} \quad \frac{|E_H^{P_U} - E_H|}{E_H} \times 100 \quad (5.6)$$

where  $E_H$  is the reference Average Energy Dissipation measured at a vertical load corresponding to  $P_D$ ,  $E_H^{P_L}$  denotes the Average Energy Dissipation measured at a vertical load corresponding to  $P_L$ , and  $E_H^{P_U}$  denotes the Average Energy Dissipation measured at a vertical load corresponding to  $P_U$ .

### 5.3.4 Test for effect of load direction.

#### Test

**Designation:** I.4

**Purpose:** To establish the effect of load direction on the system response.

**Sequence:** (a.)  $0^\circ$  (primary) direction - 3 fully reversed cycles to peak displacements of  $\pm D$ ;  
(b.)  $45^\circ$  direction - 3 fully reversed cycles to peak displacements of  $\pm D$ , loading in a direction that is  $45^\circ$  relative to the direction of loading in (a);  
(c.)  $90^\circ$  direction - 3 fully reversed cycles to peak displacements of  $\pm D$ , loading in a direction that is  $90^\circ$  relative to the direction of loading in (a), and  $45^\circ$  relative to the direction of loading in (b).

**Procedure:** The tests shall be conducted with a vertical load equal to  $P_D$ , a specimen temperature of  $T_D$  and a frequency of loading of not less than  $f_L$  or 0.004 cyc/sec. Place the specimen in the test machine and orient such that lateral loading takes place along the selected  $0^\circ$  (primary) direction; the primary direction should correspond to a principal axis of symmetry of the specimen, should one exist. Secure the specimen as necessary to the supports and loading plate. Apply the full vertical load to the specimen and allow the load to stabilize. Subject the specimen to the required 3 fully reversed cycles of lateral deformation. Remove the vertical load. The test shall be run continuously without pause between cycles. Rotate the specimen  $45^\circ$ , such that the line of action of lateral load in the new position is  $45^\circ$  relative to the original orientation. Apply the full vertical load and repeat the test. Rotate the specimen an additional  $45^\circ$ , such that the line of action of lateral load is  $90^\circ$  relative to the original line of action of lateral load. Apply the full vertical load and repeat the test. Sufficient time shall be allowed between tests at the different orientations to dissipate any heat developed during the previous test.

**Criteria:** None

#### Special

**Requirements:** Reporting of Results: The report shall include the following:

(1.) the Average Effective Stiffness in the  $0^\circ$ ,  $45^\circ$  and  $90^\circ$  directions, and the percent difference relative to the Average Effective Stiffness in the  $0^\circ$  (primary) direction, as given by

$$\frac{|K_H^{45^\circ} - K_H|}{K_H} \times 100 \quad \text{and} \quad \frac{|K_H^{90^\circ} - K_H|}{K_H} \times 100 \quad (5.7)$$

where  $K_H$  is the reference Average Effective Stiffness for loading in the primary direction,  $K_H^{45^\circ}$  denotes the Average Effective Stiffness for loading in the  $45^\circ$  direction, and  $K_H^{90^\circ}$  denotes the Average Effective Stiffness for loading in the  $90^\circ$  direction.

(2.) the Average Energy Dissipation in the  $0^\circ$ ,  $45^\circ$  and  $90^\circ$  directions, and the percent difference relative to the Average Energy Dissipation in the  $0^\circ$  (primary) direction, as given by

$$\frac{|E_H^{45^\circ} - E_H|}{E_H} \times 100 \quad \text{and} \quad \frac{|E_H^{90^\circ} - E_H|}{E_H} \times 100 \quad (5.8)$$

where  $E_H$  is the reference Average Energy Dissipation for loading in the primary direction,  $E_H^{45^\circ}$  denotes the Average Energy Dissipation for loading in the  $45^\circ$  direction, and  $E_H^{90^\circ}$  denotes the Average Energy Dissipation for loading in the  $90^\circ$  direction.

### 5.3.5 Test for effect of load plane rotation.

#### Test

**Designation:** I.5

**Purpose:** To establish the effect of load plane rotation on the system response.

**Sequence:** (a.) *Lateral load plane parallel* - 3 fully reversed cycles to peak displacements of  $\pm D$  with the lateral load plane parallel to the bottom plate;  
(b.) *Lateral load plane rotated* - 3 fully reversed cycles to peak displacements of  $\pm D$  with the lateral load plane rotated  $+\theta^\circ$  relative to the bottom plate, about an axis that lies in the plane of lateral loading and is orthogonal to the direction of lateral loading; 3 fully reversed cycles to peak displacements of  $\pm D$  with the lateral load plane rotated  $-\theta^\circ$  relative to the bottom plate, about an axis that lies in the plane of lateral loading and is orthogonal to the direction of lateral loading. The tests shall be conducted with a vertical load equal to  $P_D$ , a specimen temperature of  $T_D$  and at a frequency of loading of not less than  $f_L$  or 0.004 cyc/sec.

**Procedure:** Place the specimen in the test machine and secure as necessary to the supports and loading plate. Apply the full vertical load to the specimen and allow the load to stabilize. Subject the specimen to the required 3 fully reversed cycles of lateral deformation with the lateral load plate parallel to the bottom plate. Remove the vertical load. Repeat the test with the lateral load plane in the specified rotated positions. Sufficient time shall be allowed between tests at the different orientations to dissipate any heat developed during the previous test.

**Criteria:** None

#### Special

**Requirements:** Test Facility: The facility shall be capable of testing with the lateral load plane or top plate of the specimen in a rotated position.

Reporting of Results: The report shall include the following:

(1.) the Average Effective Stiffness for the lateral load plane rotated  $0^\circ$ ,  $+\theta^\circ$  and  $-\theta^\circ$ , and the percent difference relative to the Average Effective Stiffness in the  $0^\circ$  direction, as given by

$$\frac{|K_H^{\theta^\circ} - K_H|}{K_H} \times 100 \quad \text{and} \quad \frac{|K_H^{-\theta^\circ} - K_H|}{K_H} \times 100 \quad (5.9)$$

where  $K_H$  is the reference Average Effective Stiffness for the lateral load plane parallel,  $K_H^{\theta^\circ}$  denotes the Average Effective Stiffness for the lateral load plane rotated to  $+\theta^\circ$ , and  $K_H^{-\theta^\circ}$  denotes the Average Effective Stiffness for the lateral load plane rotated to  $-\theta^\circ$ .

(2.) the Average Energy Dissipation for the lateral load plane rotated  $0^\circ$ ,  $+\theta^\circ$  and  $-\theta^\circ$ , and the percent difference relative to the Average Effective Stiffness in the  $0^\circ$  direction, as given by

$$\frac{|E_H^{\theta^\circ} - E_H|}{E_H} \times 100 \quad \text{and} \quad \frac{|E_H^{-\theta^\circ} - E_H|}{E_H} \times 100 \quad (5.10)$$

where  $E_H$  is the reference Average Energy Dissipation for the lateral load plane parallel,  $E_H^{\theta^+}$  denotes the Average Energy Dissipation for the lateral load plane rotated to  $+\theta^\circ$ , and  $E_H^{\theta^-}$  denotes the Average Energy Dissipation for the lateral load plane rotated to  $-\theta^\circ$ .

### 5.3.6 Test for effect of bilateral load.

#### Test

**Designation:** I.6

**Purpose:** To establish the effect of bilateral loading on the system response.

**Sequence:** (a.) *bilateral load* - 3 fully reversed cycles to peak displacements of  $\pm 0.8D$  in the  $x$  direction, while a displacement of  $0.6D$  is maintained in the  $y$  direction.  
(b.) *unilateral load* - 3 fully reversed cycles to peak displacements of  $\pm 0.8D$  in the  $x$  direction.

The tests shall be conducted with a vertical load equal to  $P_D$ , a specimen temperature of  $T_D$  and at a frequency of loading of not less than  $f_L$  or 0.004 cyc/sec.

**Procedure:** Place the specimen in the test machine and secure to the supports and loading plate. Apply the full vertical load to the specimen and allow the load to stabilize. Load the specimen in the  $y$  direction to a displacement of  $0.6D$ . Apply the cyclic lateral load in the  $x$  direction to a displacement of  $\pm 0.8D$  for the required 3 fully reversed cycles. Remove the lateral load in the  $y$  direction. The test shall be run continuously without pause between cycles. Before conducting the unilateral load test, pause to allow the specimen sufficient time to dissipate any heat developed during the previous test. Apply the cyclic lateral load in the  $x$  direction to a maximum displacement of  $\pm 0.8D$  for the required 3 fully reversed cycles. The vertical load shall be maintained between bilateral and unilateral load tests.

**Criteria:** None

#### Special

**Requirements:** Test Facility: Tests shall be conducted in a facility that is capable of applying simultaneously a static vertical load, a static lateral deformation and a cyclic lateral deformation that is orthogonal to the static deformation. The test machine load capacities shall be at least 10% greater than the largest load expected in their respective directions. The static lateral load actuator shall have a stroke of at least  $0.7D$ , the cyclic lateral load actuator shall have a stroke of at least  $2D$ . The static lateral deformation may be applied under displacement control or load control, provided the displacement can be maintained within  $\pm 5\%$  of the specified displacement for the duration of the test.

Instrumentation: In addition to that specified in Section 4.3, transducers shall be in place to measure displacements at 2 points on opposite sides of the lateral load plane in the ( $y$ ) direction.

Data Acquisition: In addition to that specified in Section 4.4, record the two static lateral displacements that are orthogonal to the cyclic lateral direction.

Data Analysis: In addition to that specified in Section 4.5, the time history of static lateral displacement in the  $y$  direction shall be computed as the average of the two measured lateral displacements, i.e.,

$$\Delta_y(t) = \frac{1}{2}(\Delta_{y_1}(t) + \Delta_{y_2}(t)) \quad (5.11)$$

Construct hysteresis loops for loading in the  $x$  and  $y$  directions by plotting the lateral load ( $F_x$ , and  $F_y$ , respectively) versus the lateral displacement ( $\Delta_x$ , and  $\Delta_y$ , respectively) for the 3 cycles of the bilateral load test. Compute the Effective

Stiffness, Average Effective Stiffness, Energy Dissipation and Average Energy Dissipation in the  $x$  direction for bilateral loading. Compute the Effective Stiffness, Average Effective Stiffness, Energy Dissipation and Average Energy Dissipation for the 3 cycles of test under unilateral loading using the procedure described in Chapter 4.

Reporting of Results: The report shall include the following:

(1.) the Average Effective Stiffness measured in the  $x$  direction under bilateral loading, the Average Effective Stiffness in the  $x$  direction under unilateral loading, and the percent difference relative to the Average Effective Stiffness in the unilateral direction, as given by

$$\frac{|K_H^B - K_H|}{K_H} \times 100 \quad (5.12)$$

where  $K_H$  is the reference Average Effective Stiffness measured under unilateral loading in the  $x$  direction and  $K_H^B$  denotes the Average Effective Stiffness measured in the  $x$  direction under bilateral loading.

(2.) the Average Energy Dissipation measured in the  $x$  direction under bilateral loading, the Average Energy Dissipation in the  $x$  direction under unilateral loading, and the percent difference relative to the Average Energy Dissipation in the unilateral direction, as given by

$$\frac{|E_H^B - E_H|}{E_H} \times 100 \quad (5.13)$$

where  $E_H$  is the reference Average Energy Dissipation measured under unilateral loading in the  $x$  direction and  $E_H^B$  denotes the Average Energy Dissipation measured in the  $x$  direction under bilateral loading.



### 5.3.7 Test for effect of temperature.

#### Test

**Designation:** I.7

**Purpose:** To establish the effect of temperature on the system response.

**Sequence:** Three (3) fully reversed cycles to peak displacements of  $\pm D$ . Tests shall be conducted for internal core temperatures at the start of cyclic loading of  $T_L$ ,  $T_D$  and  $T_U$ . The difference between the internal core temperature and the external surface temperature of the specimen at the start of the test shall not exceed 22°C (40°F). Tests shall be conducted with a vertical load equal to  $P_D$ . The frequency of loading shall be not less than  $f_L$  or 0.004 cyc/sec.

**Procedure:** Bring the internal core of the specimen to the designated temperature; maintain the temperature to within  $\pm 5^\circ\text{C}$  ( $\pm 9^\circ\text{F}$ ) of that specified for a minimum of 1 hour. Place the specimen in the test machine and secure as necessary to the supports and loading plate. Apply the full vertical load to the specimen and allow the load to stabilize. Subject the specimen to the required number of fully reversed cycles of lateral deformation. The test shall be run continuously without pause between cycles. The test shall be conducted at the temperatures specified in the order  $T_L$ ,  $T_D$  and  $T_U$ .

**Criteria:** None

#### Special

**Requirements:** Test Facility: Tests shall be conducted in a facility that can heat and cool a specimen to the designated temperatures, and maintain those temperatures so as to satisfy the core temperature and maximum differential temperature requirements.

Instrumentation: A thermocouple shall be installed or embedded near the core of the specimen to measure internal core temperature. A thermocouple shall be mounted to an external surface of the specimen that is exposed to ambient room temperature to measure surface temperature.

Data Acquisition: The internal and external temperature of the specimen shall be recorded along with the load and displacement data. Temperatures shall be recorded for a period of 30 sec immediately prior to the start of the test and for a period of 30 sec immediately following the end of the test.

Report of Results: The report shall include the following:

(1.) the Average Effective Stiffness at temperatures corresponding to  $T_L$ ,  $T_D$ , and  $T_U$ , and the percent difference relative to the Average Effective Stiffness at a temperature of  $T_D$ , as given by

$$\frac{|K_H^{T_L} - K_H|}{K_H} \times 100 \quad \text{and} \quad \frac{|K_H^{T_U} - K_H|}{K_H} \times 100 \quad (5.14)$$

where  $K_H$  is the reference Average Effective Stiffness measured at a temperature corresponding to  $T_D$ ,  $K_H^{T_L}$  is the Average Effective Stiffness measured at a temperature corresponding to  $T_L$ , and  $K_H^{T_U}$  is the Average Effective Stiffness measured at a temperature corresponding to  $T_U$ .

(2.) the Average Energy Dissipation at temperatures corresponding to  $T_L$ ,  $T_D$ , and  $T_U$ , and the percent difference relative to the Average Energy Dissipation at a temperature of  $T_D$ , as given by

$$\frac{|E_H^{T_L} - E_H|}{E_H} \times 100 \quad \text{and} \quad \frac{|E_H^{T_U} - E_H|}{E_H} \times 100 \quad (5.15)$$

where  $E_H$  is the reference Average Energy Dissipation measured at a temperature corresponding to  $T_D$ ,  $E_H^{T_L}$  denotes the Average Energy Dissipation measured at a temperature corresponding to  $T_L$ , and  $E_H^{T_U}$  denotes the Average Energy Dissipation measured at a temperature corresponding to  $T_U$ .

(3.) the average internal core and external surface temperatures of the specimen at the beginning and end of each test.

### 5.3.8 Test for effect of creep.

#### Test

*Designation:* I.8

*Purpose:* To establish the effect of creep on the system response; to measure the short term creep deformation.

*Sequence:* (a.) 3 fully reversed cycles to peak displacements of  $\pm D$ . The test shall be conducted with a vertical load equal to  $P_D$ , a specimen temperature of  $T_D$  and at a frequency of loading of not less than  $f_L$  or 0.004 cyc/sec.  
(b.) Apply a vertical compressive load to the specimen equal to  $1.5P_D$ . The load shall be maintained for period of not less than 72 hours.  
(c.) repeat test sequence (a).

*Procedure:* Sequence (a): Place the specimen in the test machine and secure to the supports and loading plate. Apply the full vertical load to the specimen and allow the load to stabilize. Subject the specimen to the required 3 fully reversed cycles of lateral deformation. The test shall be run continuously without pause between cycles.  
Sequence (b.): Place the specimen in the test machine and secure to the supports and loading plate. Apply the compressive load to the specimen. The total load shall be applied within a period of 10 minutes. The total load shall be maintained for a period of not less than 72 hours, and within  $\pm 10\%$  of that specified for the duration of the test.  
Sequence (c.): Reduce the compressive load to  $P_D$ . Complete 3 fully reversed cycles to a peak displacement of  $\pm D$ . The frequency of loading shall be not less than  $f_L$  or 0.004 cyc/sec. The vertical load shall be maintained between test sequences (b) and (c).

*Criteria:* None

#### Special

*Requirements:* Data Acquisition: Record the vertical displacements ( $\delta_1$  and  $\delta_2$ ) of the lateral load plate immediately after the load is applied, and a minimum of once an hour after that, during test sequence (b).

Report of Results: The report shall include the following:

(1.) the Average Effective Stiffness of the specimen before and after the sustained load, and the percent difference relative to the Average Effective Stiffness before the sustained load, as given by

$$\frac{|K_H^c - K_H^a|}{K_H^a} \times 100 \quad (5.16)$$

where  $K_H^a$  denotes the Average Effective Stiffness of the specimen prior to sustained compression and  $K_H^c$  denotes the Average Effective Stiffness after the sustained compression.

(2.) the Average Energy Dissipation of the specimen before and after the sustained load, and the percent difference relative to the Average Energy Dissipation before the sustained load, as given by

$$\frac{|E_H^c - E_H^a|}{E_H^a} \times 100 \quad (5.17)$$

where  $E_H^a$  denotes the Average Energy Dissipation of the specimen prior to the sustained compression and  $E_H^c$  denotes the Average Energy Dissipation after the sustained compression.

(3.) the average of the measured vertical displacements of the lateral load plane as recorded each hour, during test sequence (b). Compute and report the net creep displacement ( $\delta_c$ ) of the Unit or Component, as follows

$$\delta_c = \delta_f - \delta_i \quad (5.18)$$

in which  $\delta_i$  and  $\delta_f$  denote the average of the measured vertical displacements of the lateral load plane at the beginning and end of the sustained compression sequence (b), respectively.

### 5.3.9 Test for effect of aging.

#### Test

*Designation:* I.9

*Purpose:* To establish the effect of aging on the system response.

*Sequence:* Three (3) fully reversed cycles to peak displacements of  $\pm D$ , in an un-aged condition; three fully reversed cycles to peak displacements of  $\pm D$  in a 50-year age accelerated condition. The tests shall be conducted with a vertical load equal to  $P_D$ , a specimen temperature of  $T_D$  and at a frequency of loading of not less than  $f_L$  or 0.004 cyc/sec.

*Procedure:* Place the un-aged specimen in the test machine and secure to the supports and loading plate. Apply the full vertical load to the specimen and allow the load to stabilize. Subject the specimen to the required 3 fully reversed cycles of lateral deformation. The test shall be run continuously without pause between cycles. Remove the specimen from the test machine and subject it to a suitable accelerated aging procedure. Place the aged specimen in the test machine and test as previously described.

*Criteria:* None

#### Special

*Requirements:* Test Facility: Facilities shall be available for subjecting the specimens to a suitable age acceleration procedure.

Report of Results: The report shall include the following:

(1.) the Average Effective Stiffness before and after the aging process, and the percent difference relative to the Average Effective Stiffness before aging, using the equation

$$\frac{|K_H^A - K_H|}{K_H} \times 100 \quad (5.19)$$

where  $K_H$  denotes the Average Effective Stiffness before aging and  $K_H^A$  denotes the Average Effective Stiffness after aging.

(2.) the Average Energy Dissipation before and after the aging process, and the percent difference relative to the Average Energy Dissipation before aging, as given by

$$\frac{|E_H^A - E_H|}{E_H} \times 100 \quad (5.20)$$

where  $E_H$  denotes the Average Energy Dissipation before aging and  $E_H^A$  denotes the Average Energy Dissipation after aging.

(3.) a description of the age acceleration procedure; references to relevant standards or materials on the procedure; pertinent observations or results of the age acceleration process.

### 5.3.10 Test for effect of load cycling

#### *Test*

*Designation:* I.10

*Purpose:* To establish the effect of repeated cycling on the system response.

*Sequence:* Fifty (50) fully reversed cycles to a peak displacement of  $\pm D$ . Tests shall be conducted with a vertical load equal to  $P_D$ , a specimen temperature of  $T_D$  and at a frequency of loading of not less than  $f_L$  or 0.004 cyc/sec.

*Procedure:* Place the specimen in the test machine and secure to the supports and loading plate. Apply the full vertical load to the specimen and allow the load to stabilize. Subject the specimen to the required number of fully reversed cycles of lateral deformation. The test shall be run continuously without pause between cycles.

*Criteria:* None

#### *Special*

*Requirements:* Report of Results: The report shall include the following:

- (1.) the Effective Stiffness and Energy Dissipation for all 50 cycles of the test, listed by cycle number in increasing order.
- (2.) the ratio of the  $i^{\text{th}}$  cycle to 1<sup>st</sup> cycle Effective Stiffness for each cycle of the test.
- (3.) the ratio of the  $i^{\text{th}}$  cycle to 1<sup>st</sup> cycle Energy Dissipation for each cycle of the test.

### 5.3.11 Test for effect of load cycle history.

#### Test

*Designation:* I.11

*Purpose:* To establish the effect of load cycle history on the system response.

*Sequence:* (a.) 3 fully reversed cycles at each of the displacement increments  $\pm 0.25D$ ,  $\pm 0.5D$ ,  $\pm 0.75D$  and  $\pm 1.0D$ ; then  
(b.) 3 fully reversed cycles at each of the displacement increments  $\pm 1.0D$ ,  $\pm 0.75D$ ,  $\pm 0.5D$  and  $\pm 0.25D$ .

Tests shall be conducted in the order listed, with a vertical load equal to  $P_D$ , a specimen temperature of  $T_D$ , and at a frequency of loading of not less than  $f_L$  or 0.004 cyc/sec.

*Procedure:* Place the specimen in the test machine and secure to the supports and loading plate. Apply the full vertical load to the specimen and allow the load to stabilize. Subject the specimen to the required number of fully reversed cycles of lateral deformation. Within each sequence, the test shall be run continuously without pause between cycles, or without pause between changes in displacement increments. Sufficient time shall be allowed between test sequence (a) and test sequence (b) to dissipate any heat developed during the previous test. The vertical load shall be maintained between sequences (a) and (b).

*Criteria:* None

#### Special

*Requirements:* Reporting of Results: The report shall include the following:

(1.) for each increment of displacement, the Average Effective Stiffness from test sequence (a) and the Average Effective Stiffness at the same displacement increment from test sequence (b), and the percent difference, as given by

$$\frac{|K_H^a - K_H^b|}{\{K_H^a, K_H^b\}_{\min}} \times 100 \quad (5.21)$$

where  $K_H^a$  is the Average Effective Stiffness from test sequence (a),  $K_H^b$  is the Average Effective Stiffness measured from test sequence (b), and  $\{K_H^a, K_H^b\}_{\min}$  denotes the minimum of  $K_H^a$  and  $K_H^b$ .

(3.) for each increment of displacement, the Average Energy Dissipation from test sequence (a) and the Average Energy Dissipation at the same displacement increment from test sequence (b), and the percent difference, as given by

$$\frac{|E_H^a - E_H^b|}{\{E_H^a, E_H^b\}_{\min}} \times 100 \quad (5.22)$$

where  $E_H^a$  is the Average Energy Dissipation from test sequence (a),  $E_H^b$  is the Average Energy Dissipation from test sequence (b), and  $\{E_H^a, E_H^b\}_{\min}$  denotes the minimum of  $E_H^a$  and  $E_H^b$ .

### 5.3.12 Test of re-centering capability.

*Test*

*Designation:* I.12

*Purpose:* To establish the re-centering ability of the system.

*Sequence:* Three and one-quarter (3-1/4) reversed cycles to a peak displacement of  $\pm D$ , ending at a displacement of  $+D$ ; pause, then quickly release the specimen from the displaced position. The test shall be conducted with a vertical load equal to  $P_D$ , a specimen temperature of  $T_D$ , and at a frequency of loading of not less than  $f_L$  or 0.004 cyc/sec.

*Procedure:* Place the specimen in the test machine and secure to the supports and loading plate. Apply the full vertical load to the specimen and allow the load to stabilize. Subject the specimen to the required number of reversed cycles of lateral deformation, stopping after the last quarter cycle at a displacement of  $+D$ . The test shall be run continuously without pause between the initial cycles. Allow time for the system to stabilize in the final displaced position. Quickly release the specimen from the displaced position and allow it to return to its undeformed configuration. The specimen shall experience minimal lateral resistance from the test facility as it returns to the undeformed configuration. The vertical load shall be maintained during the entire test.

*Criteria:* None

*Special*

*Requirements:* Test Facility: The facility shall have the capability to quickly release the specimen from the displaced position. Furthermore, the specimen shall be free to move under little lateral resistance as it returns to the undeformed configuration.

Data Acquisition: Record the time history of lateral deformation of the specimen after it is released from the displaced position.

Data Analysis: Measure the residual lateral displacement of the specimen after it is released.

Reporting of Results: The report shall include the hysteresis loops from the initial cycles; the time history of lateral deformation from the initial cycles and the time history of lateral deformation after the specimen is released from the displaced position. Report the residual lateral deformation of the specimen as a percentage of  $D$ .



## 5.4 Category II - Ultimate and Reserve Capacity

### 5.4.1 Ultimate Compression under Zero Lateral Load

#### *Test*

*Designation:* II.1

*Purpose:* To establish the ultimate capacity in compression under zero lateral load.

*Sequence:* Apply a vertical compressive load to the specimen until failure is observed. The vertical load shall be applied at a constant rate. The top and bottom of the specimen shall be restrained from deforming laterally.

*Procedure:* Place the specimen in the test machine and secure to the supports and loading plate. Apply the vertical compressive load to the specimen until failure is observed.

*Criteria:* Performance of the System, Unit or Component is adequate provided a minimum factor of safety of 3.0 is demonstrated under these test conditions, i.e.,

$$3.0P_D \leq P_{ULT}^C \quad (5.23)$$

where  $P_D$  is the rated vertical load carrying capacity in compression and  $P_{ULT}^C$  is the measured ultimate capacity in compression under zero lateral load.

#### *Special*

*Requirements:* Data Analysis: Plot the compression load ( $P$ ) versus vertical displacement ( $\delta$ ). The ultimate capacity  $P_{ULT}^C$  is the maximum compressive load reached during the test.

Report of Results: Report the velocity of loading, ultimate capacity in compression and compute the factor of safety. The report shall include the load-deformation plot, with  $P_{ULT}^C$  indicated. Provide a brief description of the observed mode(s) of failure.

*Exception:* The requirements of this test may be satisfied by demonstrating a load carrying capacity of  $3.0P_D$  in the undisplaced position, should the ultimate capacity of the specimen exceed that of the test facility, or the safety of personnel and equipment becomes in question during testing.

## 5.4.2 Compression in the Displaced Position

### Test

*Designation:* II.2

*Purpose:* To demonstrate reserve capacity in compression in the displaced position.

*Sequence:* Apply a vertical compressive load to the specimen while maintaining a static lateral displacement  $D_{TM}$ . The vertical load shall be applied at a constant rate. The static lateral displacement shall be maintained within  $\pm 5\%$  of  $D_{TM}$  for the duration of the test.

*Procedure:* Place the specimen in the test machine and secure to the supports and loading plate. Displace the specimen laterally by an amount  $D_{TM}$ . Apply a vertical compressive load equal to  $1.1P_U$ .

*Criteria:* Performance of the System, Unit or Component is adequate provided the specimen can sustain a compressive load of  $1.1P_U$  in the displaced position for a minimum of 1 minute, where  $P_U$  is the rated high vertical load carrying capacity of the Unit or Component, and the lateral load remains positive for the duration of the test, i.e.,

$$0 < F(t) \quad \text{for all time } t \quad (5.24)$$

where  $F(t)$  is the time history of lateral load (positive measured in the direction of displacement  $D_{TM}$ ).

### Special

*Requirements:* Data Analysis: Plot the compression load ( $P$ ) versus time and the lateral load ( $F$ ) versus time. Plot the compression load ( $P$ ) versus vertical displacement ( $\delta$ ).  
Report of Results: Report the velocity of loading and displacement  $D_{TM}$ . The report shall include the load-deformation and load-time plots. If failure is observed note the maximum compressive load applied and provide a brief description of the mode(s) of failure.

### 5.4.3 Ultimate Tension under Zero Lateral Load

#### Test

*Designation:* II.3

*Purpose:* To establish the ultimate capacity in tension under zero lateral load.

*Sequence:* Apply a vertical tensile load to the specimen until failure is observed. The vertical load shall be applied at a constant rate. The top and bottom of the specimen shall be restrained from rotating or deforming laterally.

*Procedure:* Place the specimen in the test machine and secure to the supports and loading plate. Apply the vertical tensile load to the specimen until failure is observed.

*Criteria:* Performance of the System, Unit or Component is adequate provided a minimum factor of safety of 1.1 is demonstrated under these test conditions, i.e.,

$$1.1P_T \leq P_{ULT}^T \quad (5.25)$$

where  $P_T$  is the rated capacity in tension under zero lateral load and  $P_{ULT}^T$  is the ultimate capacity in tension under zero lateral load.

#### Special

*Requirements:* Data Analysis: Plot the tensile load ( $P$ ) versus vertical displacement ( $\delta$ ). The ultimate capacity  $P_{ULT}^T$  is the maximum tensile load reached during the test.

Report of Results: Report the velocity of loading, ultimate capacity in tension, displacement corresponding to the ultimate capacity in tension, and compute the factor of safety. The report shall include the load-deformation plots, with  $P_{ULT}^T$  indicated. Provide a brief description of the observed mode(s) of failure.

*Exception:* The requirements of this test may be satisfied by demonstrating a load carrying capacity of  $1.1P_T$  in the undisplaced position, should the capacity of the specimen exceed that of the test facility, or the safety of personnel and equipment becomes in question during testing.

This test may be waived for Units or Components that have been designed to carry zero tensile load. This may be by means of an engineered mechanism or by the method of fastening the Unit or Component to the substructure or superstructure.

#### 5.4.4 Tension in the Displaced Position

##### *Test*

*Designation:* II.4

*Purpose:* To demonstrate capacity in tension in the displaced position.

*Sequence:* Apply a vertical tensile load to the specimen while maintaining a static lateral displacement  $D_{TM}$ . The vertical load shall be applied at a constant rate. The static lateral displacement shall be maintained within  $\pm 5\%$  of  $D_{TM}$  for the duration of the test.

*Procedure:* Place the specimen in the test machine and secure to the supports and loading plate. Displace the specimen laterally by an amount  $D_{TM}$ . Apply a tensile load equal to  $1.1P_T$ .

*Criteria:* Performance of the System, Unit or Component is adequate provided the specimen can sustain a tensile load of  $1.1P_T$  in the displaced position for a minimum of 1 minute, where  $P_T$  is the rated capacity of the Unit or Component under zero lateral load, and the lateral load remains positive for the duration of the test, i.e.,

$$0 < F(t) \quad \text{for all time } t \quad (5.26)$$

where  $F(t)$  is the time history of lateral load (positive in the direction of displacement  $D_{TM}$ ).

##### *Special*

*Requirements:* Data Analysis: Plot the tensile load ( $P$ ) versus time and the lateral load ( $F$ ) versus time. Plot the tensile load ( $P$ ) versus vertical displacement ( $\delta$ ).

Report of Results: Report the velocity of loading and displacement  $D_{TM}$ . The report shall include the load-deformation and load-time plots. If failure is observed note the maximum tensile load applied and provide a brief description of the mode(s) of failure.

*Exception:* This test may be waived for Units or Components that have been designed to carry zero tensile load. This may be by means of an engineered mechanism or by the method of fastening the Unit or Component to the substructure or superstructure.

#### 5.4.5 Lateral Load and Displacement Capacity under Design Vertical Load

##### *Test*

*Designation:* II.5

*Purpose:* To demonstrate lateral load and displacement capacity under the rated vertical load capacity.

*Sequence:* Apply a vertical compressive load corresponding to  $P_D$ . Impose a lateral load or displacement to the specimen until failure is observed. The vertical load shall be maintained within  $\pm 5\%$  of  $P_D$  to the extent possible until failure or instability occurs.

*Procedure:* Place the specimen in the test machine and secure to the supports and loading plate. Apply the vertical compressive load to the specimen and allow the load to stabilize. Impose the lateral load or displacement to the specimen.

*Criteria:* Performance of the System, Unit or Component is adequate provided the maximum lateral displacement achieved is greater than  $1.1D_{TM}$ .

##### *Special*

*Requirements:* Test Facility: The lateral load system shall be under load or displacement control, or some combination thereof. Control will depend on whether the ultimate capacity of the Unit or Component is force or displacement limited.

Data Analysis: Plot the lateral load ( $F$ ) versus lateral displacement ( $\Delta$ ). Record the lateral load ( $F_D$ ) corresponding to a lateral displacement of  $D$ . Plot the compression load ( $P$ ) versus vertical displacement ( $\delta$ ).

Report of Results: Report the velocity of lateral displacement, displacement  $D$ , lateral load  $F_D$ , the maximum lateral load achieved and the corresponding displacement, and the maximum lateral displacement achieved and the corresponding lateral load. The report shall include the load-deformation plots. If failure is observed note the maximum lateral displacement achieved and the corresponding lateral load and provide a brief description of the observed mode(s) of failure.

*Exception:* The requirements of this test may be satisfied by demonstrating a lateral displacement capacity of  $1.1D_{TM}$ , under a vertical load of  $P_D$ , should the ultimate displacement capacity of the specimen exceed that of the test facility, or the safety of personnel and equipment becomes in question during testing.

## 5.5 Commentary

### C5.1 Introduction

The pre-qualification series is the most thorough and comprehensive test program of the three included in the guidelines (pre-qualification, prototype and quality control). The prototype and quality control programs may actually be thought of as subsets of the pre-qualification program. The pre-qualification program was developed primarily as a basis for testing and evaluating new isolation systems, as they are researched and developed. In it, the guidelines provide a standard set of tests, from which the performance of all systems can be measured and compared on an equal basis.

The pre-qualification series is intended to be conducted only once, for an isolation system of a given "design, material and construction". The intention here is that pre-qualification tests would normally be required only when a new isolation system is introduced, or significant changes are made to an existing design. Even in the case of the latter, perhaps only selected pre-qualification tests would have to be conducted again. Small changes in the design, material or construction should not normally necessitate further pre-qualification testing. In evaluating a particular isolation system, the engineer must determine what constitutes a given "design, material and construction" and how applicable the pre-qualification test results are to the particular system being considered.

The engineer must also determine how these guidelines should be used for systems that already have a history of use and testing. For many systems, tests comparable to those described herein may already have been conducted at one time or another, but not exactly as required by the guidelines. The guidelines do not provide instructions on how to evaluate earlier test results, in terms of their meeting the requirements of the pre-qualification program. This is left up to the discretion of the engineer evaluating the isolation system. In any case, the engineer should thoroughly review all information pertaining to previously conducted tests, and determine if the procedures used and data collected are relevant to the application.

### C5.2 General Requirements for Pre-qualification Testing

- (b) The arrangement and connection of specimens being tested should accurately reproduce the field conditions. Thus, if more than one Component is being tested at once, they should be arranged and connected to the test facility as they would normally be found in the field. Also, the connection of the specimen to the load frame should be identical to the field connection, i.e., if the unit is bolted in the field, it should be bolted for the test, using the same size and number of bolts.
- (c) The guidelines recommend that a minimum of two replicates, of the same specimen be tested in the pre-qualification program. It should be noted that this is a minimum and that more replicate specimens, and specimens of different size should be tested, if possible. Clearly, the more thorough the pre-qualification program, the easier it will be for the end-user to evaluate the system. If the Isolation Units or Components are to be manufactured

in a range of sizes and capacities, pre-qualification tests could be conducted on specimens from the low, medium and high capacity ranges. However, if only two replicates of the same specimen are to be tested, the supplier should consider the end-user's needs and the capacity of the test facility, in selecting the size of the specimen to be tested.

The guidelines stipulate that all pre-qualification tests be conducted using the same two specimens. Considering all the tests required, this will be a demanding program for any system. However, to be consistent, and to provide a basis for comparison of different systems, it is important that all the tests be conducted on the same specimen. If a specimen is damaged during testing, it can be replaced, provided this is clearly noted in the report.

- (d) Whenever possible, tests should be conducted on full size specimens. Although it is not recommended, scale model specimens may be used for Category I tests, if the test could not otherwise be conducted as outlined in the guidelines because of limitations of the test facility. This may be the case, for example, when testing for the effect of frequency of loading (test I.2). Model specimens may have to be used in that test because there are few facilities in existence today that can test large scale specimens (e.g., elastomeric bearings of diameter greater than 0.5 m (20 in)) at the actual frequency of isolation. If scale model specimens are used, an effort should be made to determine multiplying factors that can be applied to the full scale results, to adjust for the factor in consideration. Multiplying factors could be determined for test I.2, for example, by testing two different scales of model specimens, each at the frequency of isolation and at the frequency at which the full size specimen would be tested. The relative difference in the measured response would yield the multiplying factor: all other things being equal, this factor could then be applied to adjust the full scale test results to the desired frequency.

It should be emphasized that scale model specimens are not acceptable for Category II tests. It is generally accepted that the ultimate and reserve capacity of a Unit or Component can only be determined from full size specimens.

- (f.) The frequency of isolation is given by

$$f_i = \frac{1}{2\pi} \sqrt{\frac{K_H g}{P_D}} \quad (5.27)$$

in which  $g$  is the acceleration due to gravity.

### C5.3 Category I - Preliminary Characterization

#### C5.3.1 Test for effect of virgin loading

Tests have shown that for certain systems the Effective Stiffness and Energy Dissipation can vary considerably during the first few "virgin" cycles of loading. However, as the system is "broken-

in" and as joints and connections take full bearing, the behavior stabilizes and is thereafter repeatable. This is true in particular for elastomeric bearings. This effect is normally overcome by subjecting every Unit manufactured to several load cycles, before it is installed. For elastomeric systems, this is referred to as "scragging" or "running-in". Some would consider this to be part of the manufacturing process.

Test I.1 is designed to determine the effect of scragging or run-in on the system response. This is accomplished by comparing the Average Effective Stiffness and Average Energy Dissipation of a specimen that has been scragged (specimen A), to one that has not (specimen B). Results are compared for a range of displacement increments. For this test it is important that the specimens be new and never loaded in any manner, hence, it is the first test in the pre-qualification series.

### *C5.3.2 Test for effect of frequency of loading.*

An isolated structure is designed to respond predominately at the isolation period, which is usually in the 1.5 to 3 second range, i.e., a frequency range of 0.67 to 0.33 cyc/sec. However, because of the capacity of most Isolation Units and Components, and the limitations of existing test equipment, it is usually impractical, and in some cases impossible, to test specimens at these relatively high frequencies of loading. Testing at a lower frequency is acceptable, provided the properties that are measured are representative of the properties of the full scale Unit or Component at the expected frequency of response. This leads to the concept of the lower and upper threshold frequencies. The lower and upper threshold frequencies bound the range of frequencies in which the measured response is within  $\pm 10\%$  of the response at a frequency of  $f_i$ .

Test I.2 is designed to establish the effect of frequency of loading on the system response, and to determine the lower ( $f_L$ ) and upper ( $f_U$ ) threshold frequencies. For the purpose of this discussion, consider three hypothetical variations in stiffness and energy dissipation with frequency, as shown in Figure 5.1. In figure 5.1(a), the stiffness or energy dissipation is seen to vary rapidly with the frequency of loading; in Figure 5.1(b) the variation is less dramatic; and in Figure 5.1(c) there is little or no variation with the frequency of loading. The cross-hatched region in each graph represents a  $\pm 10\%$  variation about the stiffness or energy dissipation measured at the frequency of isolation. Tests are first conducted at a frequency corresponding to  $f_i$  to establish the reference properties, then at frequencies greater than 0.004 cyc/sec but less than  $2f_i$ . The lower threshold frequency is that frequency at which the curve crosses the 10% boundary, below  $f_i$ ; the upper threshold frequency is that frequency at which the curve crosses the 10% boundary above  $f_i$ . The lower threshold frequency is limited to 0.004 cyc/sec, the upper threshold frequency is limited to  $2f_i$ .

All subsequent tests in the Guidelines are conducted at a frequency of not less than  $f_L$  or 0.004 cyc/sec. If  $f_L$  and/or  $f_U$  falls within the range  $f_i/2$  to  $3f_i/2$ , the principal test for seismic performance (III.1, chapter 6) must be conducted at frequencies corresponding to  $f_i/2$ ,  $f_i$  and  $3f_i/2$ .

Few if any test facilities exist today that can test full size Isolation Units or Components at the actual frequency of isolation. In most cases the lower and upper bound frequencies will have to be determined using scale model specimens.



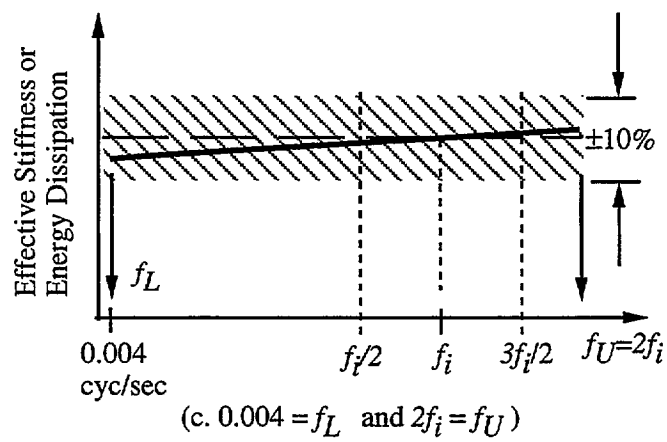
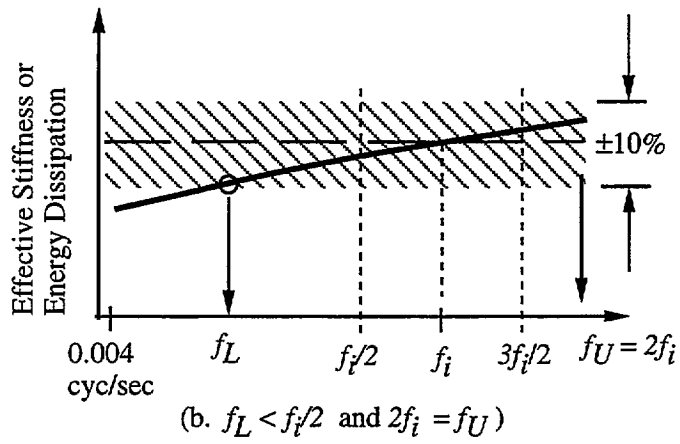
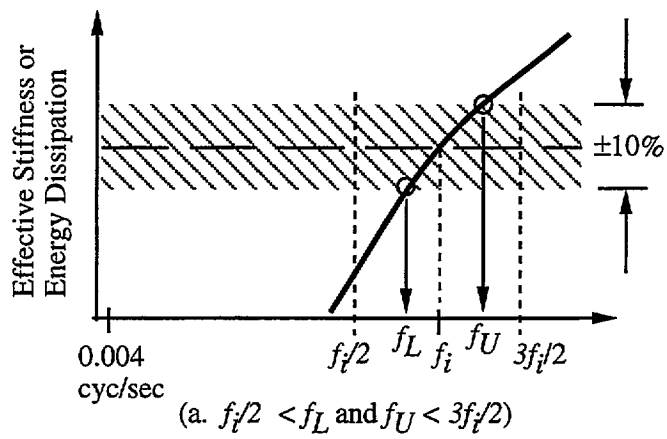

Figure 5.1. Frequency Dependence and the Threshold Frequencies.

### *C5.3.3 Test for effect of vertical load*

The vertical or axial load carried by an Isolation Unit or Component will vary during the life of the structure. The variation can take place relatively slowly, with changes in use or with the redistribution of live load, or it can vary rapidly, as during strong earthquake ground shaking. The latter can be significant, particularly for structures that are subject to large overturning moments and large vertical ground accelerations. Therefore, it is important to establish the effect of varying axial load on the isolation system response.

Test I.3 is designed to establish the effect of varying axial load by comparing the Average Effective Stiffness and Average Energy Dissipation for three vertical loads: the rated low, design and high vertical loads for the system.

### *C5.3.4 Test for effect of load direction*

Most Isolation Units and Components in use today are isotropic in the lateral plane, that is, the properties are the same regardless of the direction of loading. However, a system may in fact be anisotropic by design, or it may be anisotropic as a result of the manufacturing process. In either case, because this can have an effect on the response, it is important to establish the effect of load direction on the measured properties. This is accomplished in test I.4 by comparing the properties for loading in 3 directions:  $0^\circ$ ,  $45^\circ$  and  $90^\circ$ .

### *C5.3.5 Test for effect of load plane rotation*

A diagram is presented in Figure 5.2 to illustrate load plane rotation. In some instances the load plane may be permanently rotated as a result of fabrication or construction error. The load plane may also rotate temporarily during an earthquake due to rotation of the column or structural member to which the Unit or Component is connected. The extent to which the latter occurs will depend on the location of the Isolation System in the structure and other construction details. The system should perform as designed even with limited load plane rotation.

Test I.5 is designed to establish the effect of load plane rotation by comparing properties measured with the load plane parallel, to those obtained with the load plane rotated.

### *C5.3.6 Test for effect of bilateral load*

An Isolation System is subject to simultaneous lateral loading in two orthogonal directions during strong earthquake ground shaking. For the most part, however, Units and Components are tested under unilateral load conditions, under the assumption that the response is independent of bilateral load.

The compression-bilateral load test requires sophisticated test equipment; there are few facilities in existence today that can test under these conditions, and not at full scale and at the actual frequency of isolation. Consequently, limited research has been conducted to study the behavior of isolation systems under bilateral load. However, while the practicality of conducting such a

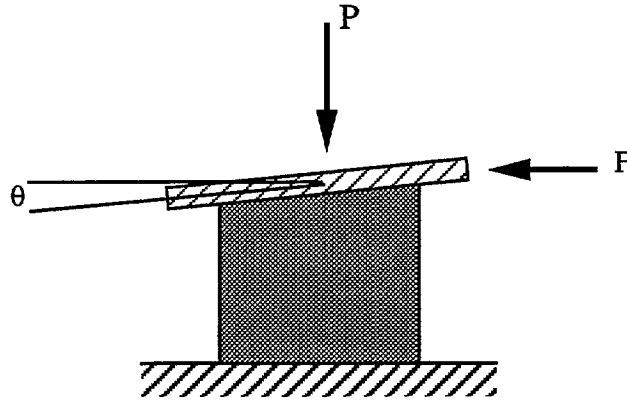

Figure 5.2. Load Plane Rotation.

test remains in question, the importance of establishing any dependence on bilateral loading is clear. The procedure outlined herein is a first attempt to develop a consistent test method for establishing bilateral load dependence: it is by no means designed to encompass the range of bilateral load cycles that a system is likely to be subject to during its lifetime. The methodology will be developed further as additional research is conducted and new, more sophisticated test facilities are built to conduct these types of tests.

In test I.6, the effect of bilateral loading is established by comparing the properties measured in the  $x$  direction under unilateral load, to the properties measured in the  $x$  direction under bilateral load conditions. The bilateral load consists of cyclic loading in the  $x$  direction while a static displacement is maintained in the  $y$  direction. Note that the resultant maximum displacement under bilateral load is equal to the rated nominal displacement capacity, i.e.

$$D = \sqrt{(0.8D)^2 + (0.6D)^2} \quad (5.28)$$

and the  $x$  displacement under unilateral loading is equal to the  $x$  displacement for the bilateral load condition ( $0.8D$ ).

#### *C5.3.7 Test for effect of temperature*

The effect of temperature on the response of the isolation system is extremely important. In many applications the Isolation System is installed near the foundation of the structure, in an environment that is not temperature controlled. In the case of a bridge, for example, the Isolation Units and Components are usually exposed directly to the weather and elements, where they can

be subject to temperature variations during a typical day of up to 35° C (65° F), with equal or greater seasonal variations. Daily and seasonal temperature variations may be less dramatic in a building, depending on the architectural details. Finally, seismic isolation may be used in regions of widely varying temperature, throughout the U.S. and world. In the U.S. this includes the extreme cold of Alaska to the extreme heat of southern California.

Test I.7 is designed to establish the effect of temperature variation on the system response by comparing the effective stiffness and energy dissipation at three different temperatures. The test temperatures correspond to the rated low, design and high operating temperatures for the system. Prior to testing, the core of the specimen must be brought to the required temperature and held for one hour. The specimen is then installed in the test facility and tested. Note that it is not necessary to test the specimen in a temperature controlled chamber; the latter would be prohibitively expensive. However, the core and external surface temperature differential requirements must be satisfied at the start of lateral cycling.

Testing at three temperatures is the recommended minimum requirement. For some systems it may be beneficial to test at more temperatures.

#### *C5.3.8 Test for effect of creep*

Vertical load carrying elements of an Isolation System may be prone to creep, depending on the materials used in fabrication of the Unit or Component. Creep may or may not adversely affect the seismic performance of the system, in any case, it is important to establish the extent of creep in the system. In test I.8, effective stiffness and energy dissipation are measured before and after a period (72 hours) of sustained compression. The creep displacement is also measured as the net deformation of the Unit or Component after 72 hours, minus the initial elastic deformation.

Note that 72 hours is a recommended minimum. The duration of the sustained load portion of the test may have to be increased if there is evidence that the specimen is still creeping at the end of the test. For this reason, the creep deformation should be monitored at least once every hour during the test. If creep is found to have a significant effect on the stiffness or energy dissipation, or the creep deformation is significant, additional testing may be needed with sustained loads of longer duration.

#### *C5.3.9 Test for effect of aging*

Aging of the isolation system, and its effect on the long term performance of the system, is perhaps the number one concern of engineers and owners considering seismic isolation. An Isolation System is expected to perform as designed for the life of the structure, which is on the order of 50 years. During that time the system may be exposed to various environmental elements or factors such as:

- ozone
- oxidation
- moisture
- toxic fluids such as oil or gas
- fumes or gases

- fire
- flood

each of which contributes to the natural process of aging of materials. Aging may also be affected by sustained compression loads and prolonged periods without lateral deformation. In some applications, steps can be taken to protect the Unit or Component from some or all of these elements. In other cases it is impossible or too expensive to provide protective systems.

At the present time there is a general lack of knowledge and data on aging effects. Furthermore, there does not exist a generally accepted, widely applicable procedure for conducting an accelerated aging test of a seismic isolation system: aging is a complex issue that deserves research attention. That notwithstanding, the objective of test I.9 is to establish a basis for studying the effects of aging on seismic isolation systems. This is done by comparing the Average Effective Stiffness and Average Energy Dissipation of an un-aged specimen, to that of a specimen that has an equivalent age of 50 years. Details of the aging process are not specified in the guidelines, it is up to the engineer to specify an appropriate aging procedure for the system. Complete details and information on the aging procedure should be provided in the report.

Two simple, but long term methods for studying the effects of aging have been proposed. The two are briefly discussed below:

The first method calls for storing extra isolation Units or Components near the isolated structure, and testing them at specified intervals of time. If, for example, five extra Units are stored near a structure after it is built, then one Unit would be tested after 1, 2, 5, 10 and 20 years, respectively. If the typical Unit is to carry vertical load, the specimens would also be stored under compression. All of the specimens would be tested before being stored, and after the specified time, using the same test procedure and the results would be compared. The drawbacks to this approach are the time it takes to get results, and the stored units are not subject to the same history of thermal, wind and seismic cycling, as the actual units in the structure.

The second method calls for testing Units and Components from an actual isolated structure, after specified intervals of time. For example, different Units from a candidate structure would be removed and tested after 1, 2, 5, 10 and 20 years. Again, all of the designated "specimens" would be tested before being installed, and after the specified time, using the same test procedure and the results would be compared. The specimen may be reinstalled in the structure after it is tested, or replaced with a new component. The drawbacks to this approach are again, the time it takes to get results, and that a structural element has to be removed from the isolated structure (it is unlikely that many owners would agree to participate in such a program).

Although these methods have their disadvantages, they would still be of significant use, and would further our knowledge of the aging process. Therefore, a tentative guideline is provided in Appendix D, for the long term storage and testing of isolation units. The procedure is included in the appendix because the test does not naturally fit into any one of the three test classes of the guidelines. Because it appears to be more practical, the procedure is based on the first method discussed above.

#### *C5.3.10 Test for effect of load cycling (system degradation)*

A reduction in Effective Stiffness or Energy Dissipation with load cycling is characteristic of some Isolation Units and Components. A system that behaves like this is sometimes said to be "degrading". Although the term generally carries with it negative connotations, a degrading system can be used safely provided the extent of degradation is limiting and is fully established by test.

Test I.10 is designed to establish the extent of degradation with load cycling. Effective Stiffness and Energy Dissipation are measured at the Design Displacement and Design Vertical Load over fifty cycles. Results are reported as the ratio of the  $i^{\text{th}}$  cycle Effective Stiffness (Energy Dissipation) over the 1<sup>st</sup> cycle Effective Stiffness (Energy Dissipation). This test is similar to, but more demanding than test III.2.

#### *C5.3.11 Test for effect of load cycle history*

An isolation system will experience cycles of randomly varying amplitude during a strong earthquake event. A system may, for example, experience a gradual buildup, followed by a gradual decline in amplitude, or, it may undergo a very large amplitude initial cycle, followed by a sequence of low amplitude cycles. The sequence or "history" of cycling may or may not have an effect on the system response. The purpose of test I.11 is to establish the effect of load cycle history on the system response. This is done, very simply, by comparing the effective stiffness and energy dissipation at equal increments of displacement, as the displacement is increased from low to high (sequence (a)), to those obtained as the displacement is decreased from high to low (sequence (b)).

The effect of load cycle history is a complex problem; test I.11 is in no way designed to encompass the range of load cycle histories that a system is likely to be subjected. Further research is needed in order to establish the most appropriate test sequence for determining the effect of load cycle history.

#### *C5.3.12 Test to establish re-centering capability*

An isolation system may or may not return to its original (undeformed) configuration following an earthquake. Whether it is desirable to have it return to its original configuration or not is a question for the designer. However, there are number of practical reasons why it should, that have to do with architectural details and maintaining continuity with adjoining structures. In any case, it is important to establish the re-centering ability of the isolation system, as part of the pre-qualification procedure.

For this test it is important that the test facility be able to quickly release the specimen from the deformed configuration. The specimen should be allowed to return to its undeformed position, under little lateral resistance but while under the design vertical load. Any lateral resistance that is provided by the test facility, due to friction or actuators, should be measured as best it can be. Note that when the specimen is released, the lateral load actuator should not be under control of the deformation. If possible, the lateral load actuator should be disconnected from the specimen.

#### *C5.4 Category II - Ultimate and Reserve Capacity*

Just as the beams, columns and footings of a building or bridge are structural members, so are the elements of a vertical load carrying Isolation System. Failure of any one member may lead to failure or collapse of the entire structure. Unlike typical structural members, however, the components of an Isolation System must carry the vertical load in an undeformed and highly displaced configuration. Thus, the ultimate or reserve capacity of the Unit or Component is to be established and checked against an accepted factor of safety for a given load condition.

The ideal series of tests for Category II would establish a failure interaction surface for the Unit or Component in question. The surface would define ultimate vertical load carrying capacity as a function of lateral displacement, and ultimate lateral load or displacement capacity versus vertical load. Hypothetical curves of this type are shown in Figure 5.3. The ideal test series would not be very practical, however, since many tests would be required to define the interaction surface accurately. The series would also be very expensive. The tests in Category II were developed, therefore, to establish select points on the failure surface or to demonstrate reserve capacity in other critical configurations.

A generally accepted procedure for testing to failure in the displaced position does not exist at the present time. The test is difficult to conduct because of the possible interaction between the specimen and test machine (i.e., the test facility can force a mode of failure that is inconsistent or unrealistic of the isolation system in service), and thus, the measured ultimate capacity may not be indicative of the true capacity when installed. For these reasons, the tests outlined in the Guidelines are designed to establish ultimate capacity in the zero displaced position, but only demonstrate reserve capacity in the displaced position. The issue of testing to determine ultimate capacity in the displaced position is an area which deserves research attention.

It is recommended that a theory for estimating ultimate capacity of a Unit or Component be developed and verified in conjunction with the Category II tests.

##### *C5.4.1 Ultimate Compression under Zero Lateral Load*

For the greater part of the life of the structure the Isolation System serves the purpose of simply transferring the dead load of the superstructure to the foundation. It is important, therefore, to establish the ultimate capacity in simple compression. This is accomplished in test II.1 by loading to failure in compression. The ultimate capacity is the peak axial load reached during the test and may not coincide with the failure load. Failure here is defined as a complete loss of vertical load carrying capacity, as a result of overstress, buckling, rupture or other event. A factor of safety of 3 is required for this load condition.

An exception is permitted in test II.1 to only demonstrate reserve capacity, if the capacity of the specimen exceeds that of the test facility, or the safety of personnel and equipment becomes in danger.

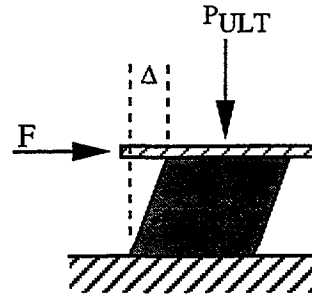
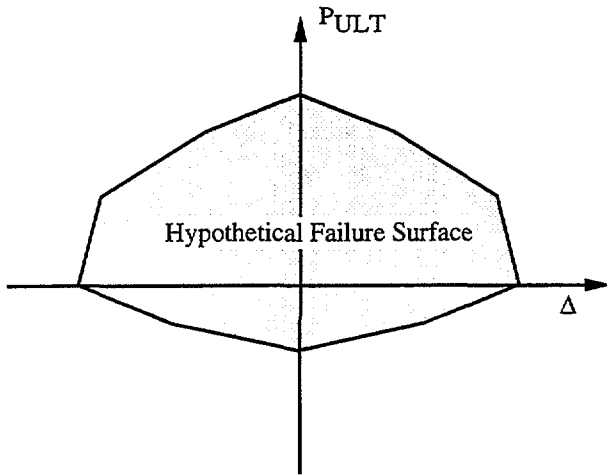

(a. Ultimate Vertical Load versus Lateral Displacement)

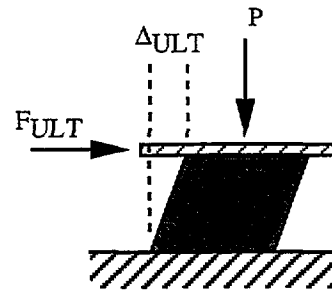
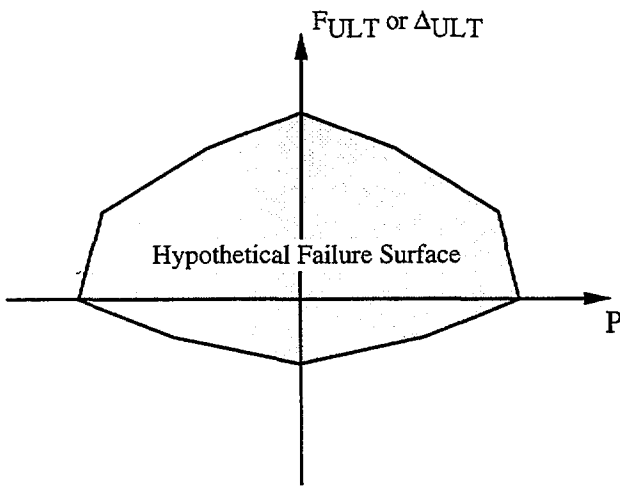

(b. Ultimate Lateral Load or Displacement versus Vertical Load)

Figure 5.3. Hypothetical Failure Interaction Diagrams.



#### *C5.4.2 Compression in the Displaced Position*

During an earthquake the Isolation System is sheared laterally, to sometimes great displacements. At this instant, the axial load on Units and Components at the extreme edges of the isolated structure will be at their maximum (or minimum), due to the structures overturning moment. Even in this deformed configuration, the system must maintain its vertical load carrying capacity. It is this state of stress that is of greatest concern to the engineer. Test II.2 is designed to demonstrate a minimum level of reserve capacity in the displaced position. A factor of safety of 1.1 is required for this load condition (note that the test load is based on  $P_U$ , the rated high vertical load carrying capacity, which is to include the effect of the overturning moment.).

#### *C5.4.3 Ultimate Tension under Zero Lateral Load*

Tension can be developed in a vertical load carrying Unit or Component, in structures that are subject to very large overturning moments. Practically speaking, however, developing tension in the undisplaced position is highly unlikely, except in the case of extreme vertical ground acceleration. Test II.3 can, however, be conducted in an ordinary universal test machine and will provide fundamental information about the capacity of the specimen. This information can be used to validate a theory for ultimate capacity, which in turn may help to estimate the capacity in the displaced position.

For Units and Components that are designed to be tension free members, this test is waived. This would be true for example for an elastomeric bearing with doweled connections or a sliding bearing that has no uplift restraint.

#### *C5.4.4 Tension in the Displaced Position*

Tension in the displaced position is another critical stress state, and one that is much more likely to occur than tension in the undisplaced position. As with compression in the displaced position, this is a difficult test to conduct. Test II.4 is designed to demonstrate a minimum level of reserve tensile capacity in the design displaced position.

#### *C5.4.5 Lateral Load and Displacement Capacity under Design Vertical Load*

Test II.5 may be thought of as the companion to test III.3. The test is designed to demonstrate reserve lateral force or displacement capacity of a Unit or Component under the nominal design vertical load. This addresses the critical state of stress sustained during strong shaking.



## **6. PROTOTYPE TESTS**

### **6.1 Introduction**

Prototype tests are project specific and are conducted to verify the design properties of the isolation system prior to construction. This chapter outlines the requirements for prototype testing.

A complete series of prototype tests includes all tests in Categories III, IV and V. This includes Categories III (Seismic Loads) and IV (Non-seismic Loads) of this chapter, as well as a complete series of quality control tests (Category V, Chapter 7).

Category III tests (seismic loads) are defined to establish the properties and characteristics of the System, Unit or Component under seismic load conditions. Average Effective Stiffness and Average Energy Dissipation are evaluated for a range of displacements, under load and environmental conditions determined to be relevant from the pre-qualification series Category I tests (Chapter 5). Stability of the system under extreme load conditions is also evaluated.

Category IV tests (non-seismic loads) are defined to demonstrate the System, Unit or Component capacity under non-seismic loads. This includes wind load, thermal displacement, thermal cycling and braking/centrifugal forces. Only those Category IV tests relevant to the project or application are required in prototype testing.

The general requirements for prototype testing are discussed in Section 6.2. Guidelines for conducting Seismic Load tests (Category III) are presented in Section 6.3. Guidelines for conducting Non-Seismic Load tests (Category IV) tests are presented in Section 6.4. Limited commentary is presented in Section 6.5.

## 6.2 General Requirements of Prototype Tests

Unless otherwise specified Prototype tests shall be conducted in accordance with the following:

- (a) Prototype tests shall include all tests outlined in Category III and applicable tests in Category IV, as shown in Table 6.1, and applicable quality control tests (Chapter 7, Table 7.1 or 7.2).
- (b) Tests shall be performed separately on two full-scale specimens of each type and size of Isolation Unit or Component.
- (c) For Systems that consist of two or more principal Components, prototype tests shall be conducted simultaneously on the combined components. The assembly and connection of the tested components shall be representative of the full System detail.
- (d) The nominal capacity of the specimen to be tested must be rated by the supplier prior to testing. Properties to be rated are presented in chapter 3.
- (e) Unless otherwise specified the frequency of isolation ( $f_i$ ) (i.e., inverse of the isolated period  $f_i = 1/T_i$ ) shall be determined from the rated Horizontal Stiffness ( $K_H$ ) and the Design Vertical Load ( $P_D$ ); the frequency for wind load tests ( $f_w$ ) shall be determined from the rated Horizontal Stiffness under Wind ( $K_w$ ) and the Design Vertical Load ( $P_D$ ).
- (f) For Systems with unidirectional Units or Components, that are free to deform in a direction that is not colinear with the principal axis of the unidirectional device, the full sequence of tests shall be conducted in at least one direction that is orthogonal to the axis of the unidirectional device, and in at least one direction that is 45 degrees to the axis of the unidirectional device.
- (g) Properly documented prototype tests previously conducted on a Unit or Component of similar size may be used to satisfy the requirements of this section, provided:
  - (1) the Unit or Component is of similar design, material and construction;
  - (2) the largest overall dimension of the Unit or Component to be tested is within  $\pm 10\%$  of the same dimension of the Unit or Component previously tested;
  - (3) most other critical dimensions are within  $\pm 15\%$  of the size previously tested.
- (h) Pre-qualification tests must have been conducted on a System, Unit or Component of similar design, material and construction prior to prototype testing.

Table 6.1. Schedule of Prototype Tests<sup>1</sup>

Category	Designation	Test
III	III.1	Effective Stiffness and Energy Dissipation
	III.2	Stability against degradation
	III.3	Stability at Maximum Lateral Displacement
IV	IV.1	Wind load
	IV.2	Thermal displacement
	IV.3	Stability with thermal cycling
	IV.4	Braking/Centrifugal force

<sup>1</sup>Prototype testing shall also include a complete series of quality control tests (chapter 7).

## 6.3 Category III - Seismic Loads

### 6.3.1 Effective Stiffness and Energy Dissipation

#### Test

*Designation:* III.1

*Purpose:* To measure Average Effective Stiffness and Average Energy Dissipation over a range of displacements, under load and environmental conditions relevant to the application.

*Sequence:* All Units and Components shall be tested in accordance with basic sequence (a) described below. Additional tests shall be conducted in accordance with applicable secondary sequences (b)-(e): relevant sequences are determined based on the results of Category I pre-qualification tests. Secondary sequences (b)-(e) shall be conducted after basic sequence (a) has been completed.

Unless otherwise specified tests shall be conducted with a vertical load equal to  $P_D$ , a specimen internal core temperature of  $T_D$ , and at a frequency of loading of not less than  $f_L$  or 0.004 cyc/sec.

(a.) *Basic sequence* - 3 fully reversed cycles at each of the displacement increments  $\pm 0.25D$ ,  $\pm 0.5D$ ,  $\pm 0.75D$  and  $\pm 1.0D$ .

(b.) *For vertical load dependent systems* - 3 fully reversed cycles to  $\pm D$  with vertical loads corresponding to  $P_L$  and  $P_U$ .

*A system is vertical load dependent if the Average Effective Stiffness at a vertical load of  $P_L$  or  $P_U$  differs by more than 10% from the Average Effective Stiffness at a vertical load of  $P_D$ , as determined by test I.3; or, the Average Energy Dissipation at vertical loads of  $P_L$  or  $P_U$  differs by more than 15% from the Average Energy Dissipation at a vertical load of  $P_D$ , as determined by test I.3.*

(c.) *For bilateral load dependent systems* - 3 fully reversed cycles to  $\pm 0.8D$  in the x direction, while a static displacement of  $0.6D$  is continuously maintained in the y direction.

*A system is bilateral load dependent if the Average Effective Stiffness in the x direction measured under bilateral load differs by more than 10% from the Average Effective Stiffness in the x direction measured under unilateral load, as determined by test I.6; or, the Average Energy Dissipation in the x direction measured under bilateral load differs by more than 15% from the Average Energy Dissipation in the x direction measured under unilateral load, as determined by test I.6.*

(d.) *For frequency dependent systems* - 3 fully reversed cycles to  $\pm D$  at frequencies corresponding to  $f/2$  and  $3f/2$ .

*A system is frequency dependent if the Average Effective Stiffness at a frequency of  $f/2$  or  $3f/2$  differs by more than 10% from the Average Effective Stiffness at a frequency of  $f_p$ , as determined by test I.2; or, the Average Energy Dissipation at a frequency of  $f/2$  or  $3f/2$  differs by more than 15% from the Average Energy Dissipation at a frequency of  $f_p$ , as determined by test I.2.*

(e.) *For temperature dependent systems - 3 fully reversed cycles to  $\pm D$ , conducted at internal core temperatures corresponding to  $T_L$  and  $T_U$  at the start of cyclic loading. The difference between the internal core temperature and the external surface temperature of the specimen at the start of each test shall not exceed 22°C (40°F).*

*A system is temperature dependent if the Average Effective Stiffness at a temperature of  $T_L$  or  $T_U$  differs by more than 10% from the Average Effective Stiffness at a temperature of  $T_D$ , as determined by test I.7; or, the Average Energy Dissipation at a temperature of  $T_L$  or  $T_U$  differs by more than 15% from the Average Energy Dissipation at a temperature of  $T_D$ , as determined by test I.7.*

Procedure:

Sequence (a): Place the specimen in the test machine and secure to the supports and loading plate. Apply the full vertical load to the specimen and allow the load to stabilize. Subject the specimen to the required number of fully reversed cycles of lateral deformation, in the order of incremental displacement,  $\pm 0.25D$ ,  $\pm 0.5D$ ,  $\pm 0.75D$  and  $\pm 1.0D$ . The test shall be run continuously without pause between cycles at a given displacement, or without pause between changes in incremental displacement.

Sequence (b): Apply the full vertical load and allow the load to stabilize. Subject the specimen to the required number of fully reversed cycles of lateral deformation. Remove the vertical load. Sufficient time shall be allowed between tests at different vertical loads to dissipate any heat developed during the previous test. Tests shall be conducted in the order of vertical load  $P_L$  then  $P_U$ .

Sequence (c): Apply the full vertical load to the specimen and allow the load to stabilize. Load the specimen in the  $y$  direction to a displacement of  $0.6D$ . Apply the cyclic lateral load in the  $x$  direction to a displacement of  $\pm 0.8D$  for the required 3 fully reversed cycles. Remove the lateral load in the  $y$  direction. The test shall be run continuously without pause between cycles.

Sequence (d): Tests shall be conducted at the frequencies specified, in the order  $f/2$  then  $3f/2$ . Sufficient time shall be allowed between tests at the different rates to dissipate any heat developed during the previous test. The vertical load shall be maintained between tests at different rates.

Sequence (e): Bring the internal core of the specimen to the specified temperature; maintain the core temperature to within  $\pm 5^\circ\text{C}$  ( $\pm 9^\circ\text{F}$ ) of that specified for a minimum of 1 hour. Place the specimen in the test machine and secure to the supports and loading plate. Apply the full vertical load to the specimen and allow the load to stabilize. Subject the specimen to the required number of fully

reversed cycles of lateral deformation. The test shall be conducted at the temperatures specified in the order  $T_L$  then  $T_U$ .

*Criteria:*

Performance of the System, Unit or Component is considered to be satisfactory if, at a given displacement increment:

(1.) for each specimen the Effective Stiffness of cycle  $i$  is within  $\pm 10\%$  of the Average Effective Stiffness for the 3 cycles, i.e.,

$$\frac{|K_H^i - K_H|}{K_H} \leq 0.10 \quad (6.1)$$

where  $K_H^i$  is the Effective Stiffness of cycle  $i$  and  $K_H$  is the Average Effective Stiffness for the 3 cycles at a given displacement increment.

(2.) and, for two specimens A and B of a common type and size, the Average Effective Stiffness of specimen A and the Average Effective Stiffness of specimen B are within 10% of each other for the 3 cycles of each series at a given displacement increment, i.e.,

$$\frac{|K_H^A - K_H^B|}{\{K_H^A, K_H^B\}_{\min}} \leq 0.10 \quad (6.2)$$

where  $K_H^A$  is the Average Effective Stiffness of specimen A and  $K_H^B$  is the Average Effective Stiffness of specimen B, and  $\{K_H^A, K_H^B\}_{\min}$  denotes the minimum of  $K_H^A$  and  $K_H^B$ .

*Exception:*

Scale model specimens may be used to quantify the properties of bilateral-load and frequency dependent systems, in lieu of tests on full-scale specimens. Tests on model specimens shall be conducted with the intent of determining multiplying factors, that can be used to adjust the full scale test results obtained in sequence (a) to reflect the expected variations with frequency and bilateral load. The scaled specimens shall be representative of full-scale prototype specimens but in no case shall they be less than 1/4 full scale.



### 6.3.2 System Degradation

#### Test

*Designation:* III.2

*Purpose:* To demonstrate stability against degradation under cyclic loading.

*Sequence:*  $N_D$  but not less than 10 fully reversed cycles to a peak displacement of  $\pm D$ . Tests shall be conducted with a vertical load corresponding to  $P_D$  and at a frequency of loading of not less than  $f_L$  or 0.004 cyc/sec.

*Procedure:* Place the specimen in the test machine and secure to the supports and loading plate. Apply the full vertical load to the specimen and allow the load to stabilize. Subject the specimen to the required number of fully reversed cycles of lateral deformation. The test shall be run continuously without pause between cycles.

*Criteria:* Performance of the System, Unit or Component is considered to be satisfactory if:

(1.) for each specimen the Effective Stiffness of cycle  $i$  is within  $\pm 20\%$  of the 1<sup>st</sup> complete cycle Effective Stiffness, for the  $N_D$  (10) cycles of the test, i.e.,

$$\frac{|K_H^i - K_H^1|}{K_H^1} \leq 0.20 \quad (6.3)$$

in which  $K_H^1$  and  $K_H^i$  denote the 1<sup>st</sup> cycle and  $i^{\text{th}}$  cycle Effective Stiffness, respectively;

(2.) and, for each specimen the Energy Dissipation of all  $N_D$  (10) cycles is at least 80% of the 1<sup>st</sup> complete cycle Energy Dissipation, i.e.,

$$0.8 E_H^1 \leq E_H^i \quad (6.4)$$

in which  $E_H^1$  and  $E_H^i$  denote the 1<sup>st</sup> cycle and  $i^{\text{th}}$  cycle Energy Dissipation, respectively.

*Exception:* This test need not be conducted as part of a pre-qualification series if test I.10 of Category I has been conducted.

### 6.3.3 Stability at Maximum Displacement

#### *Test*

*Designation:* III.3

*Purpose:* To demonstrate stability at the maximum displacement under maximum and minimum vertical loads.

*Sequence:* One fully reversed cycle to a peak displacement of  $\pm D_{TM}$ , with vertical loads corresponding to  $P_L$  and  $P_U$ . The frequency of lateral loading shall be less than 0.004 cyc/sec.

*Procedure:* Place the specimen in the test machine and secure as necessary to the supports and loading plate. Apply the full vertical load to the specimen and allow the load to stabilize. Subject the specimen to the required fully reversed cycle of lateral deformation. The tests shall be conducted at the vertical loads specified in the order  $P_L$  and  $P_U$ .

*Criteria:* Performance of the System, Unit or Component is adequate provided the full vertical load is maintained for the duration of the test and there is no observable damage to the specimen (e.g., cracking, fracture, rupture, debonding, or other such event).

#### *Special*

*Requirements:* Data Analysis: Formal analysis of data as described in Chapter 4 is not required under this test.

Report of Results: Report the vertical loads  $P_L$  and  $P_U$ , and the lateral displacement. Describe observable damage or other indications of instability.

## 6.4 Category IV - Non-seismic Loads

### 6.4.1 Wind load

#### *Test*

*Designation:* IV.1

*Purpose:* To demonstrate capacity under repeated loading to the design wind load.

*Sequence:* Twenty (20) fully reversed cycles to a peak lateral force of  $\pm F_w$ . Tests shall be conducted with a vertical load corresponding to  $P_D$  and at a frequency of loading not less than  $f_w$  or 0.004 cyc/sec.

*Procedure:* Place the specimen in the test machine and secure to the supports and loading plate. Apply the full vertical load to the specimen and allow the load to stabilize. Apply the cyclic lateral load to the specimen for the required number of fully reversed cycles of the test. The test shall be run continuously without pause between cycles.

*Criteria:* Performance of the System, Unit or Component is satisfactory provided vertical load carrying capacity is maintained for the duration of the test, the displacement corresponding to  $F_w$  is within acceptable limits and there is no visible damage to the specimen following the test.

#### *Special*

*Requirements:* Data Analysis: Compute the Effective Stiffness corresponding to load  $F_w$  for cycles 1, 2, 5, 10 and 20 using eq.(4.3).

Reporting of Results: Report the design wind load ( $F_w$ ), vertical load and frequency of loading ( $f_w$ ). Report Effective Stiffness for cycles 1, 2, 5, 10 and 20, listed by cycle number in increasing order. Report observable damage or other indications of instability.

## 6.4.2 Thermal Displacement

### *Test*

*Designation:* IV.2

*Purpose:* To demonstrate capacity under real-time thermal displacement and establish the load corresponding to the thermal displacement.

*Sequence:* Three (3) fully reversed cycles to a peak displacement of  $\pm D_r$ . Tests shall be conducted with a vertical load corresponding to  $P_D$ . The frequency of loading shall correspond to one cycle in twenty four hours.

*Procedure:* Place the specimen in the test machine and secure to the supports and loading plate. Apply the full vertical load to the specimen and allow the load to stabilize. Subject the specimen to the required number of fully reversed cycles of lateral deformation. The test shall be run continuously without pause between cycles.

*Criteria:* Performance of the System, Unit or Component is satisfactory provided vertical load carrying capacity is maintained for the duration of the test, the force corresponding to  $D_r$  is within acceptable limits and there is no visible damage to the specimen following the test.

### *Special*

*Requirements:* Data Acquisition: Record the lateral load and displacement a minimum of once an hour during lateral cycling.

Data Analysis: Formal analysis as described in Chapter 4 is not required for this test.

Reporting of Results: Report the rated thermal displacement ( $D_r$ ), the load corresponding to the thermal displacement and vertical load. Plot the lateral load versus time, and the lateral load versus displacement for the duration of the test. Report observable damage or other indications of instability.

### 6.4.3 Stability with Thermal Cycling

#### Test

*Designation:* IV.3

*Purpose:* To demonstrate capacity under repeated loading to the design thermal displacement.

*Sequence:* (a.) three (3) fully reversed cycles to a peak displacement of  $\pm D$ . The test shall be conducted with a vertical load of  $P_D$ . The frequency of loading shall be not less than  $f_L$  or 0.004 cyc/sec;  
(b.) ten thousand (10,000) fully reversed cycles to a peak displacement of  $\pm D$ . Tests shall be conducted with a vertical load corresponding to  $P_D$ . The frequency of loading shall be sufficiently slow so as to not generate excessive heat. For Units and Components that are exposed to the environment, the area surrounding and including sliding interfaces, moving parts, critical fixtures, etc., shall include dirt, debris, deicing salts and other realistic contaminants that are likely to occur over a 50 year time span;  
(c.) repeat sequence (a).

*Procedure:* Sequences (a) and (c): Place the specimen in the test machine and secure to the supports and loading plate. Apply the full vertical load to the specimen and allow the load to stabilize. Subject the specimen to the required number of fully reversed cycles of lateral deformation. Remove the vertical load. The test shall be run continuously without pause between cycles.

Sequence (b): Place the specimen in the test machine and secure to the supports and loading plate. Apply the full vertical load to the specimen and allow the load to stabilize. Subject the specimen to the required number of fully reversed cycles of lateral deformation. The test may be stopped temporarily as needed but vertical load shall be maintained at all times.

*Criteria:* Performance of the System, Unit or Component is satisfactory provided vertical load carrying capacity is maintained and there is no visible damage to the specimen following test sequence (b), and

(1.) the Average Effective Stiffness of the specimen measured in test sequence (c) is within  $\pm 10\%$  of the Average Effective Stiffness measured in test sequence (a), i.e.,

$$\frac{|K_H^c - K_H^a|}{K_H^a} \leq 0.10 \quad (6.5)$$

where  $K_H^a$  denotes the Average Effective Stiffness of the specimen prior to the 10,000 cycles and  $K_H^c$  denotes the Average Effective Stiffness after the 10,000 cycles.

(2.) and, the Average Energy Dissipation of the specimen measured in test sequence (c) is within  $\pm 15\%$  of the Average Energy Dissipation measured in test sequence (a), i.e.,

$$\frac{|E_H^c - E_H^a|}{E_H^a} \leq 0.15 \quad (6.6)$$

where  $E_H^a$  denotes the Average Energy Dissipation of the specimen prior to the 10,000 cycles and  $E_H^c$  denotes the Average Energy Dissipation after the 10,000 cycles.

*Special*

*Requirements:* Data Analysis: For test sequence (b) compute the Effective Stiffness corresponding to displacement  $D_i$ , according to eq.(4.3). Compute the stiffness a minimum of every two hundred cycles.

Reporting of Results: For test sequence (b) report the displacement  $D_i$ , vertical load and frequency of loading. Report Effective Stiffness for every two hundred cycles, listed by cycle number in increasing order. Report observable damage or other indications of instability.

*Exception:* Scale model specimens are acceptable provided they are not less than 1/4 full scale and are representative of the full scale prototype. Specimens cut from full size Units or Components are acceptable; the size and shape of the specimen is to be determined by the engineer of record.

#### 6.4.4 Braking/Centrifugal

##### *Test*

*Designation:* IV.4

*Purpose:* To demonstrate capacity under repeated loading to the design braking/centrifugal load.

*Sequence:* Two thousand (2,000) fully reversed cycles to a peak lateral force of  $\pm F_B$ . Tests shall be conducted with a vertical load corresponding to  $P_D$ . The frequency of loading shall be sufficiently slow so as to not generate excessive heat, but in no case shall the frequency of loading be less than 0.004 cyc/sec.

*Procedure:* Place the specimen in the test machine and secure to the supports and loading plate. Apply the full vertical load to the specimen and allow the load to stabilize. Subject the specimen to the required number of fully reversed cycles of lateral deformation. The test may be stopped temporarily as needed but vertical load shall be maintained at all times.

*Criteria:* Performance of the System, Unit or Component is satisfactory provided vertical load carrying capacity is maintained for the duration of the test, the displacement corresponding to  $F_B$  is within acceptable limits and there is no visible damage to the specimen following the test.

##### *Special*

*Requirements:* Data Analysis: Compute the Effective Stiffness corresponding to load  $F_B$  according to eq.(4.3). Compute the stiffness for the first ten cycles and every fortieth cycle thereafter.

Reporting of Results: Report the lateral load  $F_B$ , vertical load and frequency of loading. Report Effective Stiffness for the first ten cycles and every fortieth cycle thereafter, listed by cycle number in increasing order. Report observable damage or other indications of instability.

*Exception:* Scale model specimens are acceptable provided they are not less than 1/4 full scale and are representative of the full scale prototype.

## 6.5 Commentary

### C6.2 General requirements of Prototype Tests

- (e) The equation for the frequency of isolation is given in (5.27). The equation for the frequency of the wind load test is given by

$$f_w = \frac{1}{2\pi} \sqrt{\frac{K_w g}{P_D}} \quad (6.7)$$

in which  $g$  is the acceleration due to gravity.

### C6.3 Category III - Seismic Loads

The Category III tests are similar to those in the 1994 *Uniform Building Code* for prototype testing.

#### C6.3.1 Effective Stiffness and Energy Dissipation

The purpose of test III.1 is to evaluate the Average Effective Stiffness and Average Energy Dissipation of the System, Unit or Component, over a range of displacements and under load and environmental conditions that were found to affect the system's response, based on the results of pre-qualification tests. In this test, all specimens are tested under basic sequence (a); relevant sequences (b) through (e) are then added to the procedure, based on the evaluation of the criteria included immediately following these sequences. The results of selected Category I tests are evaluated to see if the sequence applies. To illustrate the approach, two sample test procedures are described below.

Assume a system's response is affected by vertical load, according to the results of test I.3 and the criteria stated in sequence (b) of test III.1. For this system, testing would be required in accordance with sequences (a) and (b). Tests would be conducted at  $\pm 0.25D$ ,  $\pm 0.50D$ ,  $\pm 0.75D$  and  $\pm 1.0D$ , with a vertical load of  $P_D$ , and additionally at  $\pm 1.0D$  with vertical loads of  $P_L$  and  $P_U$ . A total of 18 cycles would be required.

Assume next that a system's response is found to be affected by the frequency of load and temperature. This is based on the results of test I.2 and the criteria stated in sequence (d), and the results of test I.7 and the criteria stated in sequence (e), respectively. For this system, testing would be required in accordance with sequences (a), (d) and (e). Tests would be required at  $\pm 0.25D$ ,  $\pm 0.50D$ ,  $\pm 0.75D$  and  $\pm 1.0D$  at a frequency of  $f_i$  and temperature  $T_D$ . Additional tests would be required at  $\pm 1.0D$  at frequencies of  $f_i/2$  and  $3f_i/2$  and temperature  $T_D$ , and at  $\pm 1.0D$  at a frequency of  $f_i$  and at core temperatures of  $T_L$  and  $T_U$ . A total of 24 cycles would be required.

The performance criteria in test III.1 address two critical issues: stability of Effective Stiffness over three cycles and repeatability of Average Effective Stiffness between two specimens.



### *C6.3.2 System Degradation*

Test III.2 is comparable to test I.10, with the exception of the number of cycles required. Some degradation in Average Effective Stiffness and Average Energy Dissipation is acceptable, provided the properties stabilize after a certain number of cycles. A system that continues to degrade in performance is not acceptable; performance criteria have been established accordingly. This test can be waived if it is to be conducted as part of the pre-qualification series.

### *C6.3.3 Stability at Maximum Displacement*

Test III.3 is similar in principle to test II.5. During an earthquake the Isolation System will be required to sustain varying levels of axial load, simultaneously with large lateral displacements. The test is designed to demonstrate stability of the system in the displaced position.

## *C6.4 Category IV - Non-Seismic Loads*

In terms of the guidelines, a non-seismic load may be defined as any live load that is not a result of earthquake ground shaking. The primary non-seismic load for buildings is wind. For bridges it includes wind, thermal cycling and braking/centrifugal forces. Obviously not all tests listed in this category are applicable to all structures. The engineer is responsible for selecting those tests that are appropriate to the application.

It should be noted that it was not the intention here to include all possible non-seismic loads. The four included are considered the most important for building and bridge applications, and are applicable to the largest percentage of structures currently, or likely to be isolated in the future. Tests for other non-seismic loads may be added as needed, and modeled after the tests included here.

### *C6.4.1 Wind Load*

The response of an isolated structure to wind load can be quite different from the seismic response. The initial stiffness of the system is designed to be high to resist wind load; under these relatively low magnitude loads the system responds at a higher frequency (i.e.,  $f_w > f_i$ ) and the response may be nearly perfectly elastic. This is in contrast to the highly nonlinear behavior expected during an earthquake. Test IV.1 is designed to demonstrate the functionality of the system to repeated cycles at the design wind load. The performance criteria require that the displacement due to wind load be within acceptable limits and there be no significant residual displacement.

### *C6.4.2 Thermal Displacement*

Thermal displacements can be significant in bridges because of their long spans and direct exposure to the sun. A bridge will experience daily, as well as seasonal variations in temperature. A bridge will experience thousands of thermal cycles throughout its life. Thermal cycling is not

exclusive to bridges, however, and should be checked for any structure that is subject to daily or seasonal temperature variations and has relatively large span distances between supports.

Test IV.2 is designed to demonstrate capacity under real-time thermal displacement and establish the peak load corresponding to the rated thermal displacement. A very slow rate of loading is specified to simulate an actual 24 hour thermal cycle. The real-time loading is important because lateral creep may significantly affect the loads.

#### *C6.4.3 Stability with Thermal Cycling*

In bridge applications the Isolation System must endure thousands of thermal cycles, spread out over years of service, and still perform its isolation functions under a major seismic event. The purpose of test IV.3 is to demonstrate adequate performance after prolonged thermal cycling. The test is modeled after the California Department of Transportation, "groaner" test, that is required of all Isolation Systems installed in bridges in California. In this test the Average Effective Stiffness and Average Energy Dissipation are measured before and after 10,000 cycles to the rated Thermal Displacement. The environment in and around the Unit or Component is to be contaminated with dirt and debris, to the extent that it would be expected to collect in the installed system, since this might affect the system's performance.

Test IV.3 is conducted at a rate that is faster than the real-time rate of thermal cycling; therefore, it is important to monitor the temperature of the specimen during this test to ensure that excessive heat is not generated. An increase in temperature may be uncharacteristic of the field behavior and may result in poor performance. If excessive heat is being generated the frequency of loading should be reduced or the test should be temporarily stopped until the heat is dissipated.

#### *C6.4.4 Braking/Centrifugal*

Bridges are also subject to live loads due to braking, and in curved or banked bridges, centrifugal forces. A bridge may be subject to thousands of cycles of these forces during its lifetime. Test IV.4 is designed to demonstrate capacity of the system under these lateral loads. It is sufficient to test only at a lateral load  $F_b$  that is the greater of the rated braking or centrifugal force. Also, as with test IV.3, the temperature of the specimen should be monitored to ensure that excessive and uncharacteristic heat is not generated.

## **7. QUALITY CONTROL TESTS**

### **7.1 Introduction**

Quality Control (QC) tests are project specific and are conducted to: (1) verify the as-built properties of the isolation system, and (2), monitor the quality and consistency of the manufacturing process. These tests are, to a certain extent, specific to a particular type of isolation system, because of the design and materials used in the device. QC tests are included here for elastomeric and sliding isolation systems. The guidelines in this chapter should be thoroughly reviewed by the engineer to determine their applicability to other hybrid isolation systems.

Included in the guidelines for QC testing are Completed Unit- and Production-tests. Tests that are conducted of the assembled Isolation Unit or Component, as one of the final steps in the manufacturing process, are referred to herein as Completed Unit Tests. These are similar to the Category I through IV tests presented in earlier chapters. The Completed Unit tests make up the Category V tests of the guidelines.

Tests conducted during fabrication on the materials or component parts of the isolation Unit or Component, are referred to herein as Production tests. These tests are unlike the others included in the guidelines, however, production tests are extremely important to the overall quality control of the system and should be included in any such QC program. Production tests are included in the guidelines for elastomeric and sliding systems.

Guidelines for conducting quality control tests for elastomeric systems are presented in Section 7.2. Guidelines for conducting quality control tests for sliding systems are presented in Section 7.3. Limited commentary is presented in Section 7.4.



## 7.2 Elastomeric Systems

### 7.2.1 General Requirements

Unless otherwise specified, quality control tests of elastomeric isolation systems shall be conducted in accordance with the following:

- (a) All Units manufactured shall be subject to the Completed Unit tests specified in Section 7.2.2, and shown in Table 7.1. Quality control testing shall also include the Production tests specified in Section 7.2.3.
- (b) The nominal capacity of the specimen to be tested must be rated by the supplier prior to testing. Properties to be rated are presented in chapter 3.
- (c) Pre-qualification tests must have been conducted on a System, Unit or Component of similar design, material and construction, prior to quality control testing.
- (d) Prototype tests must have been conducted on a System, Unit or Component of the same design, material and construction, prior to quality control testing.

Table 7.1. Schedule of Quality Control Completed Unit Tests: Elastomeric Systems

Category	Designation	Test
V	V.1	Sustained Compression
	V.2	Effective Stiffness and Energy Dissipation
	V.3	Compression Stiffness

## 7.2.2 Completed Unit Tests

### 7.2.2.1 Sustained Compression

#### *Test*

*Designation:* V.1

*Purpose:* To check for debonding or delamination of elastomeric units, and to verify the load carrying capacity of the specimen.

*Sequence:* Apply a vertical compressive load equal to  $1.5P_D$  to the specimen. The total load shall be maintained for 12 hours, and within  $\pm 10\%$  of that specified for the duration of the test.

*Procedure:* Place the specimen in the test machine and secure to the supports and loading plate as necessary. Apply the full vertical load to the specimen and allow the load to stabilize.

*Criteria:* The System, Unit or Component shall be visually inspected for faults a minimum of 2 times during the test: within the first 30 minutes of testing and during the last 30 minutes of testing. The specimen shall be set aside for disposition by the engineer of record if:

- it fails to sustain the applied load for any reason for the duration of the test,
- there exist 3 or more separate surface cracks that are 2 mm (0.08 in) wide and 2 mm (0.08 in) deep,
- the bulging pattern indicates a misplaced or omitted steel or elastomer layer,
- the bulging pattern indicates debonding of an elastomer and steel laminate.

#### *Special*

*Requirements:* Data Acquisition: Vertical load shall be recorded not less than once every 30 minutes. A continuous strip chart recorder is suitable for recording vertical load.

*Exception:* The duration of the test may be reduced to 3 hours, provided the supplier has documented evidence that there have been no failures, between 3 and 12 hours, in consecutive tests of at least 1000 production Units of a similar design, material and construction.

### 7.2.2.2 Effective Stiffness and Energy Dissipation

#### Test

*Designation:* V.2

*Purpose:* To determine the Effective Stiffness and Energy Dissipation of the specimen.

*Sequence:* Five (5) fully reversed cycles to a peak displacement of  $\pm D$ . Tests shall be conducted with vertical load equal to  $P_D$ , a specimen temperature of  $T_D$ , and at a frequency of loading of not less  $f_L$  or 0.004 cyc/sec.

*Procedure:* Place the Isolation Unit(s) in the test machine and secure as needed to the loading plates. Apply a compressive load to the specimen equal to  $P_D$  and allow the load to stabilize. The total load shall be applied within a period of not more than 2 minutes. Subject the specimen to the required number of fully reversed cycles of lateral deformation. The test shall be run continuously without pause between cycles.

*Criteria:* The Isolation Unit shall be set aside for disposition by the engineer of record if:

(1.) the Average Effective Stiffness is not within  $\pm 15\%$  of the average of the Average Effective Stiffnesses of all Units of a similar design and capacity, i.e.,

$$\frac{|K_H - K_{H_{AVE}}|}{K_{H_{AVE}}} \leq 0.15 \quad (7.1)$$

in which  $K_H$  is the Average Effective Stiffness of a particular Unit and  $K_{H_{AVE}}$  is the average of the Average Effective Stiffnesses of all Units of a similar design and capacity,

(2.) and, the Average Energy Dissipation is not within  $\pm 15\%$  of the average of the Average Energy Dissipation of all Units of a similar design and capacity, i.e.,

$$\frac{|E_H - E_{H_{AVE}}|}{E_{H_{AVE}}} \leq 0.15 \quad (7.2)$$

in which  $E_H$  is the Average Energy Dissipation of a particular Unit and  $E_{H_{AVE}}$  is the average of the Average Energy Dissipations of all Units of a similar design and capacity.

#### Special

*Requirements:* Report of Results - Indicate whether the Isolation Unit passed or failed the test based on the stated performance criteria. For Units that fail the test explain in sufficient detail the reason for disposition of the Unit.

*Exception:* For lots of 4 or fewer, due to the low sample size, it is the responsibility of the engineer of record to decide the acceptance of individual Units based on a review of all available test data.

### 7.2.2.3 Compression Stiffness

#### Test

*Designation:* V.3

*Purpose:* To measure the compression stiffness of the specimen.

*Sequence:* Three (3) fully reversed vertical load cycles between  $0.6P_D$  and  $1.4P_D$ . Tests shall be conducted for a specimen temperature of  $T_D$ .

*Procedure:* Apply a compressive load equal to  $1.5P_D$  and maintain the load for 1 minute: the maximum load shall be reached within a period of not more than 10 minutes. Reduce the compressive load to  $0.6P_D$  and maintain the load for 1 minute. Complete 3 cycles of loading between  $0.6P_D$  and  $1.4P_D$ , at a uniform rate of loading that is in the range of 1 to 2 min/cycle. Record the maximum and minimum vertical loads and the maximum and minimum vertical displacements ( $\delta_1, \delta_2$ ) for each of the 3 cycles.

*Criteria:* The System, Unit or Component shall be set aside for disposition by the engineer of record if the Average Effective Vertical Stiffness differs by more than  $\pm 20\%$  from the average of the Average Effective Vertical Stiffnesses of all Isolation Units of a similar design and capacity, i.e.,

$$\frac{|K_V - K_{V_{AVE}}|}{K_{V_{AVE}}} \leq 0.20 \quad (7.3)$$

in which  $K_V$  is the Average Effective Vertical Stiffness of a particular Unit and  $K_{V_{AVE}}$  is the average of the Average Effective Vertical Stiffnesses of all Units of a similar design and capacity.

#### Special

*Requirements:* Data Analysis: The vertical displacement ( $\delta$ ) of the Isolation Unit for any load shall be computed as the average of the measured vertical displacements ( $\delta_1, \delta_2$ ), i.e.,

$$\delta(t) = \frac{1}{2}(\delta_1(t) + \delta_2(t)) \quad (7.4)$$

The Effective Vertical Stiffness ( $K_{V_i}$ ) for each cycle  $i$  shall be computed as follows,

$$K_{V_i} = \frac{P^+ - P^-}{\delta^+ - \delta^-} \quad (7.5)$$

in which  $P^+$  and  $P^-$  correspond to the maximum and minimum vertical load, respectively, for cycle  $i$ , and  $\delta^+$  and  $\delta^-$  correspond to the maximum and minimum vertical displacement, respectively, for cycle  $i$ . The Average Effective Vertical Stiffness ( $K_V$ ) shall be computed for the 3 cycles of the test, as given by

$$K_V = \frac{1}{3} \sum_1^3 K_{V_i} \quad (7.6)$$



Report of Results: Indicate whether the Isolation Unit passed or failed the compression stiffness test based on the stated performance criteria. For Units that fail the test explain in sufficient detail the reason for disposition of the Unit.

*Exception:* For lots of 4 or fewer, due to the low sample size, it is the responsibility of the engineer of record to decide the acceptance of individual Units based on a review of all available test data.

## 7.2.3 Production Tests

### 7.2.3.1 General

This section outlines the requirements for production testing of the elastomer used in elastomeric Isolation Units. A total of ten tests are listed in the schedule. The tests are generally considered to be the recommended minimum for a typical laminated elastomeric Isolation Unit (e.g., high damping rubber or lead-rubber bearing). Other tests may be specified by the engineer as needed.

Most of the production tests are based on ASTM standards. For those tests that are, the relevant standard is referenced. Further details are outlined as necessary and modifications or exceptions to the standard noted. Minimum performance criteria are noted for each test and are usually based on a design specified value. These performance criteria are considered to be minimum requirements. Materials that do not meet these minimum requirements shall be rejected.

The production tests recommended in these Guidelines are similar, and in part based on the tests outlined in ASTM D 4014, *Standard Specification for Plain and Steel-Laminated Elastomeric Bearings for Bridges*: the specification may be referenced for additional information and guidance as needed. It should be noted that ASTM D4014 was developed for standard elastomeric bridge bearings *and not* elastomeric seismic isolation bearings. The performance criteria and performance measures in ASTM D4014 may be inappropriate for seismic isolation units.

### 7.2.3.2 Test Specimens

A minimum of three specimens from each batch of elastomer shall be tested, for all tests given in Section 7.2.3.3 to qualify the elastomer for the project, unless more are specifically required by the referenced standard. A high quality mixing process shall be used to ensure uniformity amongst different batches.

Unless otherwise specified tests shall be conducted on specimens cut from sheets or on specially molded test pieces. Tests may be conducted on specimens taken from actual bearings, at the request of the engineer. Results are to be reported as the average of the test results for the three specimens.

### 7.2.3.3 Test Schedule

- (a) *Hardness* - Durometer hardness shall be determined and reported in accordance with ASTM D2240. Tests shall be conducted using a Type A indenter.
- (b) *Shear Modulus and Energy Dissipation* - Shear modulus and energy dissipation shall be determined using a three-bar shear specimen, as shown in Figure 7.1. The virgin elastomer shall be subject to 6 fully reversed cycles at the design shear strain. The temperature of the specimen shall be equal to the nominal design temperature ( $T_D$ ) and the frequency of loading shall be equal to the isolation frequency ( $f_i$ ). Load and displacement shall be recorded continuously during the test.

Shear modulus shall be computed for cycles 4 through 6 from the recorded load-deflection curve, using the formula

$$G_i = \frac{B}{2LH} \frac{(F^+ - F^-)}{(u^+ - u^-)} \quad (7.7)$$

in which  $F^+$  and  $F^-$  are the maximum and minimum forces for cycle  $i$ ,  $u^+$  and  $u^-$  are the maximum and minimum displacements for cycle  $i$ , and  $L$ ,  $H$  and  $B$  are the length, width and height of the elastomer pad, respectively. The average of the shear moduli for cycles 4, 5 and 6 shall be reported and shall be within the target value specified by the design.

The energy dissipation shall be computed for cycles 4 through 6 from the recorded load-deflection curve. The energy dissipation is equal to the area enclosed by a loop. The average of the three energy dissipations shall be reported and shall be within the target value specified by the design.

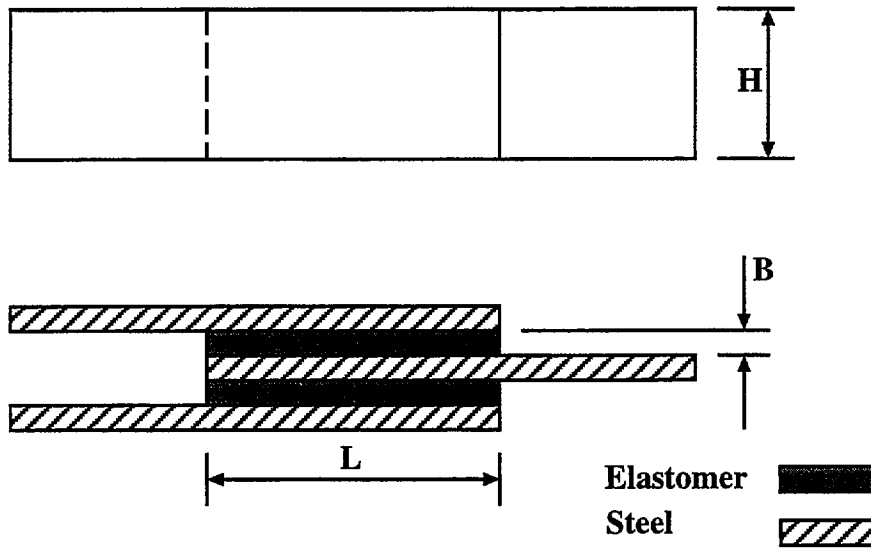

Figure 7.1. Three-bar shear specimen

- (c) *Tensile Strength and Elongation at Break* - Tensile properties shall be determined in accordance with ASTM D413. Ultimate tensile strength shall be equal to or greater than the minimum tensile strength specified by the design. Elongation at break shall be equal to or greater than the elongation at break specified by the design.
- (d) *Bond Strength* - Bond of the elastomer to steel shall be determined in accordance with ASTM D429 Method B. Express the average peel strength in newtons per millimeter

(pound-force per inch) of width. The average peel strength shall be equal to or greater than that specified by the design. The failure mode shall be 100% rubber tear.

(e) *Compression Set* - Compression set shall be determined in accordance with ASTM D395 Method B. Unless otherwise specified by the engineer a Type 1 or 2 specimen shall be selected that is nearest in thickness to the thickness of the elastomer layer of the Isolation Unit. Specimens shall be conditioned for 22 hours at the temperature specified by the engineer. The compression set shall be less than the maximum permissible specified by the design.

(f) *Low Temperature Properties* - Low temperature properties shall be determined, as necessary, in accordance with the elastomer grade rating. Properties to be determined include the following:

*Low Temperature Stiffness (Hardness)* - in accordance with ASTM D2240. Specimens shall be conditioned for 22 hours at the temperature specified by the engineer. The increase in hardness shall be less than the maximum permissible specified by the design.

*Low Temperature Brittleness* - in accordance with ASTM D2137 Method A. Specimens shall be conditioned for  $3.0 \pm 0.5$  min at the specified temperature. None shall fail.

*Low Temperature Compression Set* - in accordance with ASTM D1229. The same type of specimen shall be used for low temperature compression set as is used for ambient temperature compression set. Specimens shall be conditioned for 7 days at the specified temperature. The low temperature compression set measured at 30 minutes shall be less than that specified by the design.

(g) *High Temperature Aging* - High temperature aging shall be determined in accordance with ASTM D573. Specimens shall be conditioned for 7 days at the specified temperature. The change in durometer hardness (Type A), relative to the unaged hardness, shall be less than the maximum permissible specified by the design. The change in tensile strength and elongation at break, relative to the unaged values, shall be less than the maximum permissible specified by the design.

(h) *Ozone Resistance* - Ozone resistance shall be determined in accordance with ASTM D1149. Tests shall be conducted using specimen type A. Specimens shall be conditioned at 20% strain and  $40 \pm 2^\circ\text{C}$  ( $104 \pm 4^\circ\text{F}$ ) for 100 hours. The ozone test partial pressure shall be  $50 \pm 5$  MPa. On completion of testing the specimens shall be inspected using a 7x magnification lens. The ozone resistance shall be regarded as satisfactory if there are no visible cracks in the specimens.

### 7.3 Sliding Systems

#### 7.3.1 General Requirements

Unless otherwise specified, quality control tests of sliding isolation systems shall be conducted in accordance with the following:

- (a) All Units manufactured shall be subject to the Completed Unit tests specified in Section 7.3.2, and shown in Table 7.2. Quality control testing shall also include the Production tests specified in Section 7.3.3.
- (b) The nominal capacity of the specimen to be tested must be rated by the supplier prior to testing. Properties to be rated are presented in chapter 3.
- (c) Pre-qualification tests must have been conducted on a System, Unit or Component of similar design, material and construction, prior to quality control testing.
- (d) Prototype tests must have been conducted on a System, Unit or Component of the same design, material and construction, prior to quality control testing.

Table 7.2. Schedule of Quality Control Completed Unit Tests: Sliding Systems

Category	Designation	Test
V	V.1	Sustained Compression
	V.2	Effective Stiffness and Energy Dissipation

## 7.3.2 Completed Unit Tests

### 7.3.2.1 Sustained Compression

#### *Test*

*Designation:* V.1

*Purpose:* To check for debonding or delamination of sliding units that are susceptible to creep, and to verify the load carrying capacity of the specimen.

*Sequence:* Apply a vertical compressive load equal to  $1.5P_D$  to the specimen. The total load shall be maintained for 12 hours, and within  $\pm 10\%$  of that specified for the duration of the test.

*Procedure:* Place the specimen in the test machine and secure to the supports and loading plate as necessary. Apply the full vertical load to the specimen and allow the load to stabilize.

*Criteria:* The System, Unit or Component shall be visually inspected for faults a minimum of 2 times during the test, within the first 30 minutes of testing and during the last 30 minutes of testing. The Isolation Unit shall be set aside for disposition by the engineer of record if:

- it fails to sustain the applied load for any reason for the duration of the test,
- there is evidence of deformation, extrusion, cracking or debonding of the interface or backing materials,
- there is evidence of excessive creep, beyond that permitted by the design.

Where possible the Unit shall be disassembled to allow for inspection of the sliding interface.

#### *Special*

*Requirements:* Data Acquisition: Vertical load shall be recorded not less than once every 30 minutes. A continuous strip chart recorder is suitable for recording vertical load.

*Exception:* The duration of the test may be reduced to 3 hours, provided the supplier has documented evidence that there have been no failures, between 3 and 12 hours, in consecutive tests of at least 1000 production Units of a similar design, material and construction.

This test may be waived for systems that are shown to be independent of creep, based on a review of the results of test I.8

### 7.3.2.2 Effective Stiffness and Energy Dissipation

*Test*

*Designation:* V.2

*Purpose:* To determine the Effective Stiffness and Energy Dissipation of the specimen.

*Sequence:* Five (5) fully reversed cycles to a peak displacement of  $\pm D$ . Tests shall be conducted with a vertical load equal to  $P_D$ , a specimen temperature of  $T_D$ , and at a frequency of loading of not less than  $f_L$  or 0.004 cyc/sec.

*Procedure:* Place the Isolation Unit(s) in the test machine and secure as needed to the loading plates. Apply a compressive load to the specimen equal to  $P_D$  and allow the load to stabilize. The total load shall be applied within a period of not more than 2 minutes. Subject the specimen to the required number of fully reversed cycles of lateral deformation. The test shall be run continuously without pause between cycles.

*Criteria:* The Isolation Unit shall be set aside for disposition by the engineer of record if:

(1.) the Average Effective Stiffness is not within  $\pm 15\%$  of the average of the Average Effective Stiffnesses of all Units of a similar design and capacity, i.e.,

$$\frac{|K_H - K_{H_{AVE}}|}{K_{H_{AVE}}} \leq 0.15 \quad (7.8)$$

in which  $K_H$  is the Average Effective Stiffness of a particular Unit and  $K_{H_{AVE}}$  is the average of the Average Effective Stiffnesses of all Units of a similar design and capacity,

(2.) and, the Average Energy Dissipation is not within  $\pm 15\%$  of the average of the Average Energy Dissipation of all Units of a similar design and capacity, i.e.,

$$\frac{|E_H - E_{H_{AVE}}|}{E_{H_{AVE}}} \leq 0.15 \quad (7.9)$$

in which  $E_H$  is the Average Energy Dissipation of a particular Unit and  $E_{H_{AVE}}$  is the average of the Average Energy Dissipations of all Units of a similar design and capacity.

In addition, for systems that exhibit an elastic- or rigid-perfectly plastic hysteretic behavior, the Isolation Unit shall be set aside for disposition by the engineer of record if:

(3.) the Static Coefficient of Friction is not within  $\pm 15\%$  of the average of the Static Coefficients of Friction of all Units of a similar design and capacity, i.e.,

$$\frac{|\mu_s - \mu_{s_{AVE}}|}{\mu_{s_{AVE}}} \leq 0.15 \quad (7.10)$$

in which  $\mu_s$  is the Static Coefficient of Friction of a particular Unit and  $\mu_{s_{AVE}}$  is the average of the Static Coefficients of Friction of all Units of a similar design and capacity,

(4.) and, the Average Kinetic Coefficient of Friction is not within  $\pm 15\%$  of the average of the Average Kinetic Coefficients of Friction of all Units of a similar design and capacity, i.e.,

$$\frac{|\mu_k - \mu_{k_{AVE}}|}{\mu_{k_{AVE}}} \leq 0.15 \quad (7.11)$$

in which  $\mu_k$  is the Kinetic Coefficient of Friction of a particular Unit and  $\mu_{k_{AVE}}$  is the average of the Kinetic Coefficients of Friction of all Units of a similar design and capacity.

*Special*

*Requirements:* Report of Results - Indicate whether the Isolation Unit passed or failed the test based on the stated performance criteria. For Units that fail the test explain in sufficient detail the reason for disposition of the Unit.

*Exception:* For lots of 4 or fewer, due to the low sample size, it is the responsibility of the engineer of record to decide the acceptance of individual Units based on a review of all available test data.



### 7.3.3 Production Tests

#### 7.3.3.1 General

This section outlines the requirements for production testing of the materials and parts of sliding Isolation Units and Components. It has been developed with the intent of providing general instruction for production testing of a typical, generic sliding device. A total of six tests are listed in the schedule. The tests are generally considered to be the recommended minimum for a generic sliding device. Other tests may be specified by the engineer as needed.

For each test a performance criterion is established that is based on a design specified value. These performance criteria are considered to be minimum requirements. Materials and parts that do not meet or exceed these requirements should be rejected and should not be used in the fabrication of Units or Components.

#### 7.3.3.2 Test Specimens

Unless otherwise specified the results should be reported as the average of the results from 3 independent test specimens or 3 independent readings, unless more are specifically required by a referenced standard or procedure. Material properties shall be determined from specimens cut from the stock used in the fabrication of the device, or from test pieces molded from the same stock or bulk material. Tests may be conducted on specimens taken from actual devices, at the request of the engineer.

#### 7.3.3.3 Test Schedule

- (a) *Surface Roughness* - The finish of the sliding surface shall be established by visual comparison to three calibrated roughness specimens. The surface finish of the three calibrated roughness specimens shall correspond to the maximum, mean and minimum surface roughness as specified for production of the Isolation Units. The surface roughness of the sliding surface shall be within the range of the specified minimum to maximum surface roughness. The finish of the three calibrated roughness specimens shall be determined and expressed in terms of Roughness Average,  $R_a$ , as defined in ANSI/ASME B46.1-1985 Appendix C. The Roughness Average shall be determined along 3 non-colinear lines, oriented at angles of 0°, and 45° and 90° degrees from the 0° degree direction. Ten readings evenly spaced along each line shall be taken. The Roughness Average reported shall be the average of the 30 readings.
- (b) *Trueness of Surface* - In order to ensure full contact of the bearing pad and sliding surface for the range of motion anticipated, the surfaces are to be true to within the design specified value. The deviation from flatness of a plane surface shall be established by direct measurement of the surface and shall be within the design specified tolerance. The deviation from a theoretical circular or spherical surface shall be established by direct measurement and shall be within the design specified tolerance.

- (c) *Interface Material Properties* - Interface materials (bearing pad and sliding surface) shall have the mechanical, physical, frictional, wear and weathering properties as specified by the design. Where applicable, materials may be specified by an accepted standard and shall have properties to within the specified tolerance as outlined by the standard, and determined using accepted test procedures. New or unique materials that are not specified by an accepted standard shall be tested using accepted procedures and shown to be in compliance with the specification. Typical properties to be evaluated might include tensile strength, elongation to break, creep, corrosion and wear characteristics, and low and high temperature properties. Some of these may not be applicable or other property tests may be specified by the engineer as needed.
- (d) *Backing Material Properties* - Backing plate materials shall have the mechanical, physical, and weathering properties as specified by the design. Materials may be specified by an accepted standard, where applicable, and shall have properties to within the specified tolerance as outlined by the standard and determined using accepted test procedures. New or unique materials that are not specified by an accepted standard shall be tested using accepted procedures and shown to be in compliance with the design specification.
- (e) *Bearing Pad Attachment* - The primary means of attachment (bonding or mechanical) of the bearing pad to the backing plate shall be established by a submitted and accepted quality control procedure. The quality control procedure used for production units shall be the same as that used in the prototype units.
- (f) *Sliding Interface Attachment* - The primary means of attachment (bonding or mechanical) of the sliding interface to the backing plate shall be established by a submitted and accepted quality control procedure. The quality control procedure used for production units shall be the same as that used in the prototype units.

## 7.4 Commentary

### C7.1 Introduction

Unlike the generic pre-qualification and prototype tests presented in earlier chapters, quality control tests tend to be specific to a particular type of isolation system. This is because QC tests measure properties of the material or device that provide some indication of the overall quality of the product, and these tests are unique to the materials and construction of the product. For example, a critical quality control issue for elastomeric systems is the integrity of the steel-elastomer bond: this is evaluated using one type of test procedure. A critical quality control issue for sliding systems is the finish of the sliding surface: this is evaluated using another unique test procedure. The only QC test that is common to both sliding and elastomeric systems in the guidelines, and should be included in the QC program of any system, is the Completed Unit test to measure the effective stiffness and energy dissipation (test V.2).

With that in mind, guidelines are included for conducting QC tests of elastomeric and sliding systems. The procedures are divided according to the type of system. Quality control procedures could be developed for other hybrid isolation systems, using the tests presented here as a guide.

### C7.2 Elastomeric Systems

#### C7.2.1 General Requirements

The guidelines state that all Units manufactured shall be subject to the Completed Unit tests. This includes the sustained compression test (V.1), the effective stiffness and energy dissipation test (V.2), and the compression stiffness test (V.3). In testing all units, the guidelines may be considered overly conservative, excessive and even too demanding. Less demanding alternatives have been proposed, that are based on testing a sample of specimens from a lot, with triggers to test additional specimens if one or more fails. For example, one alternative would test 20% of all Units manufactured, and test an additional three for every one that fails from the initial sample. However, there are a number of specific reasons for testing all the units manufactured:

- without a comprehensive quality control program, the Completed Unit tests are the only way to ensure the as-built properties of all isolation units. Some have even suggested placing more emphasis on the Completed Unit tests, and less emphasis on quality control during production (the reason being that the proof of quality is in performance of the final product).
- in light of the new and evolving nature of this technology, it is prudent to require that all specimens be tested, and that there be a documented record of the properties of all units installed in an isolated structure, because the failure of an isolated structure due to poor quality control could be detrimental to the future of the technology.
- sampling statistics show that a large sample size is needed in order to guarantee a reasonable level of confidence, with an even larger sample required if a number of units from the original sample fail.

## *C7.2.2 Completed Unit Tests*

### *C7.2.2.1 Sustained Compression*

The sustained compression test has been used in the United States for many years to test the integrity of the steel-elastomer bond in elastomeric isolation Units. The principal behind the test is that a delamination or debondment in the Unit will be exasperated and become evident when it is placed under vertical load. The origin of the test presumably goes back to research conducted in the 1980's at the University of California, Berkeley, in which a newly manufactured bearing failed under simple compression, after only a few days of being installed in a bridge model. The failure was attributed to a defect in the steel-elastomer bond.

The sustained compression test is simple to conduct, the principal drawback is the time required to complete the test. To illustrate this, consider for example a building application that requires 200 elastomeric units. Testing single units in one test facility, and not counting the time required to load and unload specimens from the test facility, the sustained compression tests for the project would take over three months to complete. Thus, there is great impetus to develop a faster, more effective method for detecting debonding in elastomeric units. Alternatives have been proposed that include a shear test under no axial load, or a direct tension test.

Evidence collected to date suggests that if a defect is present, it will become apparent in the first three hours of the test. The exception in test V.1 takes note of this fact.

### *C7.2.2.2 Effective Stiffness and Energy Dissipation*

Test V.2 is the final check of the seismic properties of the Unit or Component before it is installed in the structure. The test is similar to test III.1 of the Prototype series, the difference being that the specimen is subject to only a single sequence of 5 lateral load cycles.

The performance criteria in test V.2 focuses on consistency of the properties within a lot of units, by comparing the stiffness and energy dissipation of a particular unit to the average of the properties for the entire lot. Note that the criteria are not based on the rated capacity of the system, or the results of the prototype tests, as it has been suggested they should, by some. It is important to note also that if a unit does not satisfy the criteria it is set aside for disposition by the engineer of record: it is recognized that the unit may be viable and could be used for some other purpose or project.

### *C7.2.2.3 Compression Stiffness*

Test V.3 is a basic test that has been used for elastomeric systems for some time. It is simple to conduct and provides important information about the vertical stiffness of the system. This test is not specified for the sliding systems, since they are in general, extremely stiff in the vertical direction. The compression stiffness test would be important for any system that has some flexibility in the vertical direction.

Note that only Units of equal capacity and design vertical stiffness should be tested simultaneously in a dual specimen configuration (Figure 4.3 (b)). Also, some have suggested that only twenty percent of all Isolation Units and Components manufactured in a given group or lot be subject to the compression stiffness test.

### *C7.2.3 Production Tests*

None

## *C7.3 Sliding Systems*

### *C7.3.1 General Requirements*

### *C7.3.2 Completed Unit Tests*

#### *C7.3.2.1 Sustained Compression*

The sustained compression test for sliding systems is important for systems that are susceptible to creep under sustained load. In certain designs, the bearing pad or sliding interface materials may deform and creep under sustained load. Therefore, just as with the elastomeric systems, the sliding system should be subjected to a sustained compression test, to check for extruding materials, cracks, etc. It is desirable, also, to inspect the sliding interface after this test, if possible.

#### *C7.3.2.2 Effective Stiffness and Energy Dissipation*

Again, as with the same test for the elastomeric systems, test V.2 is the final check of the as-built properties of the isolation system, before it is installed. The test is identical to the test for the elastomeric systems. There are some differences in the data analysis, for systems that have an elastic- or rigid-perfectly plastic response (e.g. a pure sliding device).

### *C7.3.3 Production Tests*

None



## **8. RESEARCH NEEDS IN TESTING OF SEISMIC ISOLATION SYSTEMS**

### **8.1 Introduction**

The concept of seismic isolation have been around since near the turn of the century (Buckle and Mayes, 1990), at least as reported or eluded to in the literature and patent records. However, the technology really began to emerge in the late 60's and early 70's as a result of advances in materials processing and computer analysis. Since then, tremendous progress has been made on both the experimental and analytical fronts, and the technology is now being used with confidence. Nevertheless, there are issues that remain to be resolved and require additional research effort. The issues that pertain specifically to testing of Isolation Units and Components are described in the sections to follow. These issues need to be resolved and the results incorporated into a revised set of guidelines.

### **8.2 Ultimate Capacity**

Very few Isolation Units and Components have been tested to complete failure, particularly full scale specimens. One reason for this is the extremely large load carrying capacity of most Units and Components and the limitations of existing test facilities. Consequently, the true factor of safety of many of these systems remains an unknown.

Research is needed to investigate the ultimate load carrying capacity of a variety of Isolation Units and Components. The research should include tests on full scale and scale model specimens, and include both vertical and lateral ultimate capacity. Results of the full scale and scale model tests should be correlated so that future tests can be conducted on smaller, less expensive specimens. Failure load models should be refined or developed for these systems and the results verified by experiments. Results of this research should be incorporated into Category II tests described in these guidelines.

### **8.3 Aging**

The life expectancy of a typical structure today is about 50 years. This would be true for an isolated structure as well. The question of greatest concern to the owner, architect and engineer of an isolated structure is: Will the system perform as designed for an earthquake that occurs in the structure's 50th year? This is a question of aging of materials for most systems. For some systems there is also the concern over "dwell" time, i.e., the period between earthquakes during which there is no movement at all across the isolation interface.

To establish the effect of aging, one approach would be to build a complete prototype system, test, wait 50 years and then retest. This of course is impractical. The alternative is to use an accelerated aging technique that would reduce the time required by orders of magnitude and produce an equivalent aging effect. There are several ASTM standards for accelerated aging that are widely used by other industries. These standards, however, were not developed with seismic isolation in mind and for that reason their applicability remains in question. In addition, many of these standards use small samples or simply test materials and not complete components parts. Research should be undertaken to (1) critically review existing aging procedures and determine

their applicability to isolation systems, (2) develop a new, or modify an existing standard aging test which would be applicable to all types of Isolation Units and Components, (3) develop guidelines and procedures for storing duplicate Units and Components near the installed isolation system, that can be tested at a later date in order to verify aging effects and the accelerated aging process. A draft guidelines for the long-term storage and testing of specimens is included in Appendix D. Results of this research should be incorporated into Category I tests described in these guidelines.

#### **8.4 Delamination/Debonding in Elastomeric Isolation Bearings**

Delamination or debonding of the steel and rubber layers in an elastomeric isolation bearing is a serious problem that can lead to failure. This is an issue related to the quality of manufacture and quality control testing. It raises the question: what effect does debonding have on the performance of the system and how can it best be detected before the Unit is installed?

Presently, quality control testing of laminated elastomeric bearings includes a 12 hour sustained compression test (i.e., test V.1). The test has been shown to provide a reasonable check on debonding. The major drawback of the test, as mentioned previously, is the time required. Research is needed to develop a faster and more efficient technique for detecting delamination and debonding. Possible alternatives include a shear test with zero vertical load, or a direct tension test. Research is needed to investigate these and other nonintrusive/nondestructive techniques.

#### **8.5 Bilateral Load**

During an earthquake an Isolation System is subject to lateral loads in two orthogonal directions. The system responds by deforming simultaneously in two orthogonal directions, and in some cases in a torsion mode. The majority of tests conducted to date by researchers, however, have been uniaxial. The effect of bilateral load on stiffness, yield level and energy dissipation remains to be investigated for many systems. The results may prove to be insignificant, at least as related to the design process, but nevertheless should be examined.

Very limited data is available from bilateral load tests of Isolation Units and Components (Nagarajiah, et al , 1989). Additional research is needed and should be expanded to include a variety of Isolation Systems. Research should focus on evaluating the force-deflection behavior and energy dissipation characteristics for a variety of bilateral load cases. Results should be interpreted with design and modeling in mind. A standard bilateral load history should be developed that would establish bilateral load dependence.

#### **8.6 Viscous and Hysteretic Damping**

Energy Dissipation is often expressed in terms of a percent equivalent viscous damping. One reason for this is because design and modeling of an isolated structure is usually based on a simple viscous damped single-degree-of-freedom oscillator. The Energy Dissipation in most systems, however, is judged to be best represented by some combination of viscous and hysteretic damping. Ideally, the two components of damping would be evaluated independently by



experiment and then used in a more sophisticated model of the isolated structure. Research is needed to develop an appropriate test procedure for evaluating the viscous and hysteretic components of damping of an isolation system.

## **8.7 Load Cycle History**

A structure supported on elastomeric isolation bearings is designed to response predominately at the isolation period, however, due to the random nature of earthquake ground motion the displacement amplitude of the isolation system varies with time. The amplitude *and* effective frequency of response can vary for structures supported on sliding or hybrid isolation systems. Nevertheless, the properties of the system should be stable or predictable even under varying load conditions. The manner and extent to which system properties vary for different load histories is of concern.

Work has been done recently on the effect of load history on elastomeric isolation bearings (Aiken, Clark and Kelly, 1992). Additional work is required along these lines and should be expanded to include a variety of systems. One or more standard load cycle histories should be developed that would establish history dependence. Results of this research should be incorporated into Category I tests described in these Guidelines.



## 9. SUMMARY

Existing codes for seismic isolation require prototype and quality control tests of every isolation system designed and installed in the United States. At the present time, however, standards do not exist for conducting these tests, consequently, test results are subject to unknown variability. This report represents the first step in the effort to develop a national standard for testing seismic isolation systems.

Guidelines have been presented for conducting pre-qualification, prototype and quality control tests. The guidelines are independent of the application and isolation system. They have been developed to cover all viable isolation systems. The guidelines have been developed with the assistance of industry, researchers and practitioners, in the hope that the document will be a resource for those involved in the design and construction of isolated structures, and that it will foster the use of this promising technology.

The guidelines (pre-standard) presented will ensure the systematic characterization of isolation system properties, allow for direct comparison of different systems, and prescribe a minimum level of acceptable performance of the system in service. The guidelines should also facilitate development of high quality systems and instill a certain level of confidence in the installed systems.



## REFERENCES

- Aiken, I., Kelly, J.M., and Tajirian, F.F., "Mechanics of Low Shape Factor Elastomeric Seismic Isolation Bearings," University of California at Berkeley, Earthquake Engineering Research Center Report, UCB/EERC-89/13.
- Buckle, I.G. and Mayes, R.L., 1990, "Seismic Isolation: History, Application and Performance - A World View," *Earthquake Spectra*, Vol. 6, Number 2, May.
- Chopra, A. K., **Dynamics of Structures: Theory and Applications to Earthquake Engineering**, Prentice-Hall, New Jersey, 1995.
- Constantinou, M.C., Kartoum, A.K., Reinhorn, A.M., and Bradford, P., 1992, "Sliding Isolation System for Bridges: Experimental Study," *Earthquake Spectra*, Vol. 8, No. 3, pp 321-344.
- Guide Specifications for Seismic Isolation Design* (1991), American Association of State Highway and Transportation Officials, Washington, D.C.
- Huffman, G.K., 1985, "Full Base Isolation for Earthquake Protection by Helical Springs and Viscodampers," *Nuclear Engineering and Design*, Vol. 84, Number 3, pp. 331-338.
- Ikonomou, A.S., 1985, "Alexisismon Isolation Engineering for Nuclear Power Plants," *Nuclear Engineering and Design*, Vol. 85, Number 2, pp. 201-216.
- Kelly, J.M., 1993, "State-of-the-Art and State-of-the-Practice in Base Isolation," ATC 17-1, Proceedings of Seminar on Seismic Isolation, Passive Energy Dissipation, and Active Control, March 11-12, 1993, San Francisco CA, Applied Technology Council, Redwood City, CA.,
- Mostaghel, N. and Khodaverdian, M., 1988, "Seismic Response of Structures Supported on R-FBI System," *Earthquake Engineering and Structural Dynamics*, Vol. 16, pp 839-854.
- Nagarajaiah, S., Reinhorn, A.M., and Constantinou, M.C., 1989, "Nonlinear Dynamic Analysis of three Dimensional Base Isolated Structures (3D-BASIS)," National Center for Earthquake Engineering Research Report, NCEER-89-0019, August.
- Proceedings of a Seminar and Workshop on Base Isolation and Passive Energy Dissipation*, Applied Technology Council, ATC-17, San Francisco, CA., March 12-14, 1986.
- Shenton, H.W., (1994a), "Draft Guidelines for Quality Control Testing of Elastomeric Seismic Isolation Systems," NISTIR 5345, National Institute of Standards and Technology, Gaithersburg, Maryland, February, 1994.
- Shenton, H.W., (1994b), "Draft Guidelines for Quality Control Testing of Sliding Seismic Isolation Systems," NISTIR 5371, National Institute of Standards and Technology, Gaithersburg, Maryland, March, 1994.

Shenton, H.W., (1994c), "Draft Guidelines for Pre-qualification and Prototype Testing of Seismic Isolation Systems," NISTIR 5359, National Institute of Standards and Technology, Gaithersburg, Maryland, March, 1994.

*Uniform Building Code* (1994), International Conference of Building Officials, Whittier, California.

Zayas, V., Low, S. and Mahin, S., 1990 "A Simple Pendulum Technique for Achieving Seismic Isolation," *Earthquake Spectra*, Vol. 6, May 1990.

## APPENDIX A. SYMBOLS AND NOTATION

The symbols and notation below apply to the guidelines outlined in this document:

- $D$  = Design Displacement;
- $D_c$  = Creep displacement;
- $D_{TM}$  = Total maximum displacement;
- $D_t$  = Thermal displacement;
- $D_v$  = Vertical displacement;
- $E_H$  = Average Energy Dissipation over  $n$  cycles;
- $E_H^{( )}$  = Average Energy Dissipation over  $n$  cycles for different specimens or for varied conditions as outlined in the test, ( ) = A,B,a,b,O,P,R or T;
- $E_{H_i}$  = Energy Dissipation for cycle  $i$ , e.g.,  $E_{H_1}$  is the 1st cycle Energy Dissipation;
- $f_i$  = isolation frequency and the inverse of the isolation period ( $T_i$ );
- $f_L, f_U$  = threshold frequencies that define the range of frequencies in which the measured response is within a certain percent of the response at a frequency of  $f_i$ ;
- $f_w$  = frequency for wind load test;
- $F$  = lateral load;
- $F^+, F^-$  = maximum lateral load ( $\max\{F\}$ ) for a single cycle, minimum lateral load ( $\min\{F\}$ ) for a single cycle;
- $F_B$  = lateral load due to braking or centrifugal forces;
- $F_w$  = wind load;
- $F_x$  = lateral load in the x direction;
- $F_x^+, F_x^-$  = maximum lateral load in the x direction for a single cycle, minimum lateral load in the x direction for a single cycle;
- $F_y$  = lateral load in the y direction;
- $K_H$  = Average Effective Stiffness over  $n$  cycles;
- $K_H^{( )}$  = Average Effective Stiffness over  $n$  cycles for different specimens or for varied conditions as outlined in the test, ( ) = A,B,a,b,O,P,R or T;
- $K_{H_i}$  = Effective Stiffness for cycle  $i$ , e.g.,  $K_{H_1}$  is the 1st cycle Effective Stiffness;
- $K_v$  = Effective Vertical Stiffness at the Design Vertical Load;
- $K_w$  = Effective Stiffness at the Design Wind Load;

$N_D$	=	degradation cycle limit;
$N_t$	=	thermal cycle limit;
$P$	=	vertical load;
$P_L$	=	low vertical load;
$P_D$	=	design vertical load;
$P_T$	=	tensile load;
$P_U$	=	high vertical load;
$P_{ULT}^C$	=	ultimate capacity in compression under zero lateral load;
$P_{ULT}^T$	=	ultimate capacity in tension under zero lateral load;
$T_i$	=	isolation period;
$T_L$	=	low temperature;
$T_D$	=	design temperature;
$T_U$	=	high temperature;
$\Delta$	=	lateral displacement;
$\Delta^+, \Delta^-$	=	maximum lateral displacement ( $max\{\Delta\}$ ) for a single cycle, minimum lateral displacement ( $min\{\Delta\}$ ) for a single cycle;
$\Delta_1, \Delta_2$	=	measured lateral displacements;
$\Delta_x$	=	lateral displacement in the x direction;
$\Delta_{x1}, \Delta_{x2}$	=	measured lateral displacement in the x direction;
$\Delta_x^+, \Delta_x^-$	=	maximum lateral displacement in the x direction for a single cycle, minimum lateral displacement in the x direction for a single cycle;
$\Delta_y$	=	lateral displacement in the y direction;
$\Delta_{y1}, \Delta_{y2}$	=	measured lateral displacement in the y direction;
$\delta$	=	vertical displacement;
$\delta_1, \delta_2$	=	measured vertical displacements.
$\theta^*, \theta$	=	lateral load plane rotation;



## APPENDIX B. GLOSSARY OF TERMS

The definitions below apply to the guidelines outlined in this document:

Accuracy	A "generic concept of exactness related to the closeness of agreement between the average of one or more test results and an accepted reference value" (ASTM E177-90a).
Average Effective Stiffness	The average of the Effective Stiffnesses over a number of cycles for a specified set of test conditions.
Average Energy Dissipation	The average of the Energy Dissipation over a prescribed number of cycles for a specified set of test conditions.
Design Displacement	The minimum lateral seismic displacement at the center of rigidity, required for design of the seismic Isolation System.
Effective Stiffness	Lateral force in the Isolation System, Unit or Component, divided by the lateral displacement.
Energy Dissipation	The area enclosed by a single hysteresis loop.
Hysteresis Loop	A curve generated by plotting force versus displacement, which under cyclic loading generally forms a loop.
Hysteretic Damping	A damping mechanism which is proportional to displacement and in-phase with velocity, but is independent of the frequency of response.
Isolation System	The collection of structural elements that includes all individual Isolation Units, Components, other structural members and connections that transfer force between the substructure and superstructure and form the isolation interface. The Isolation System also includes any other lateral restraint system that is utilized to resist non-seismic loads, or serves as an ultimate restraint device.
Isolation Unit	A flexible structural element of the Isolation System which permits large lateral deformations under seismic excitation. An Isolation Unit provides all restoring force and damping attributes in a single integrated structural element. An Isolation Unit may also be used as a structural member for non-seismic loads.
Isolation Component	A flexible structural element of the Isolation System which permits large lateral deformations under seismic excitation. An Isolation Component provides primarily a restoring force or damping attribute in a single structural element. An Isolation Component may also be used as a structural member for non-seismic loads. An Isolation Component in and of itself cannot fulfill the restoring force and energy dissipation properties required of the System.

Isolation Interface	The boundary between the upper portion of the structure (superstructure) which is isolated, and the lower portion of the structure (substructure) which is not isolated.
Precision	A "generic concept related to the closeness of agreement between test results obtained under prescribed like conditions from the measurement process being evaluated" (ASTM E177-90a).
Rate of Load	The velocity of the actuator or load fixture expressed as distance per unit time.
Frequency of Load	The number of full cycles of loading completed per unit time, usually expressed as cycles/sec.
Viscous Damping	A damping mechanism which is proportional to velocity and is dependent on the frequency of response.
Uncertainty	A statistical estimate of the error limits of a quantity obtained from a calibration equation (ASTM E74-91).

## **APPENDIX C. TEST FACILITIES**

Schematic drawings of six test facilities are presented in this Appendix. This includes facilities owned and/or operated by:

Earthquake Engineering Research Center, University of California at Berkeley, Richmond, California.

Dynamic Isolation Systems, Inc., Berkeley, California.

Earthquake Protective Systems, Inc., San Francisco, California.

Bridgestone Corporation, Yokohama, Japan.

Oiles Corporation, Fujisawa, Japan.

Rockwell International/U.S. Department of Energy, Energy Technology Engineering Center, Canoga Park, California.

The facilities range in capacity and capability and all except one were built to test a single Isolation Unit. The facility owned by Dynamic Isolation Systems, Inc. was built to test Isolation Units in a dual configuration. The drawings are presented simply for reference and to illustrate the diversity of test facilities in use today.

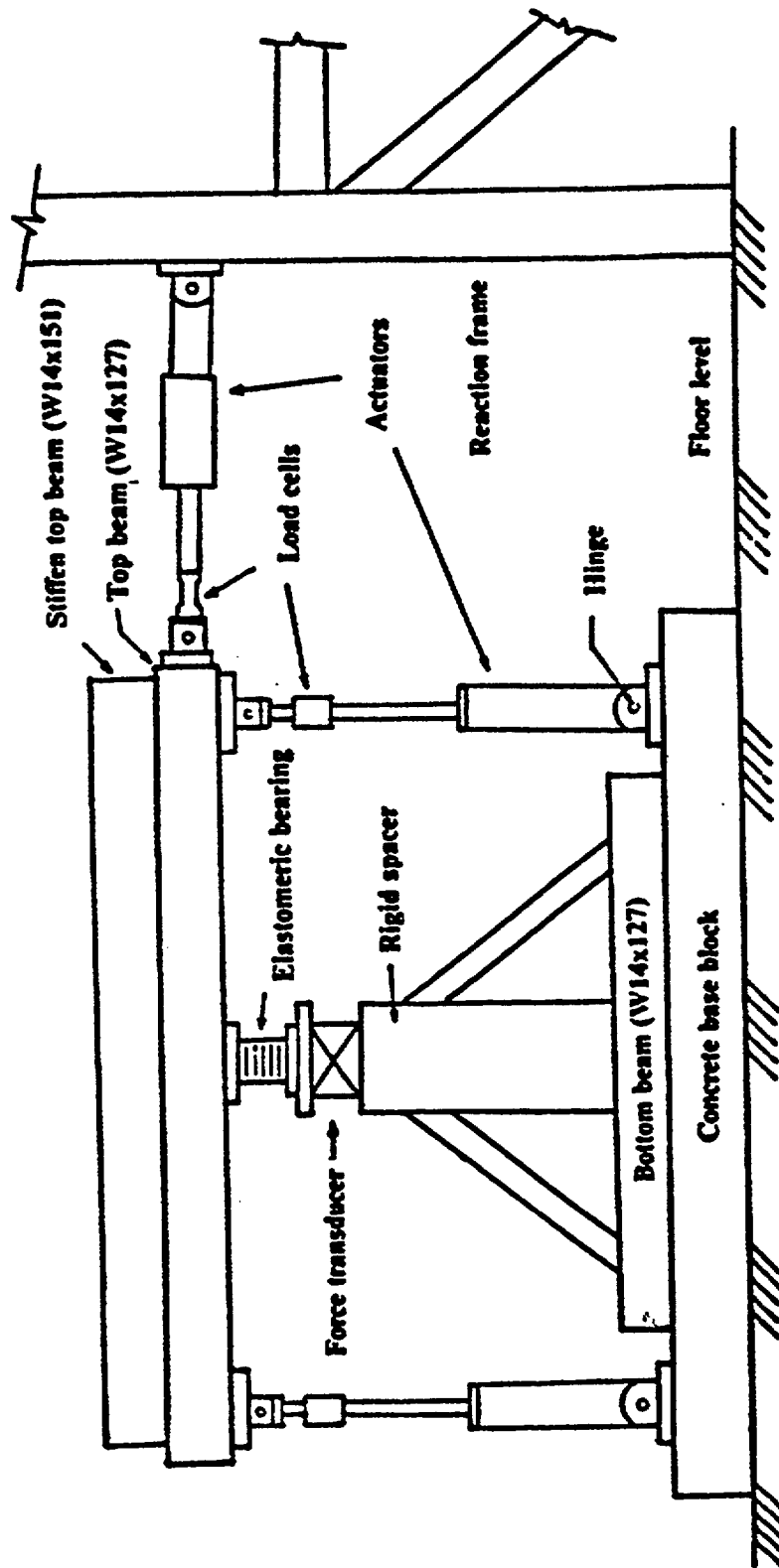

Figure C.1 Isolation Unit Test Facility, Earthquake Engineering Research Center, University of California at Berkeley, Richmond, California

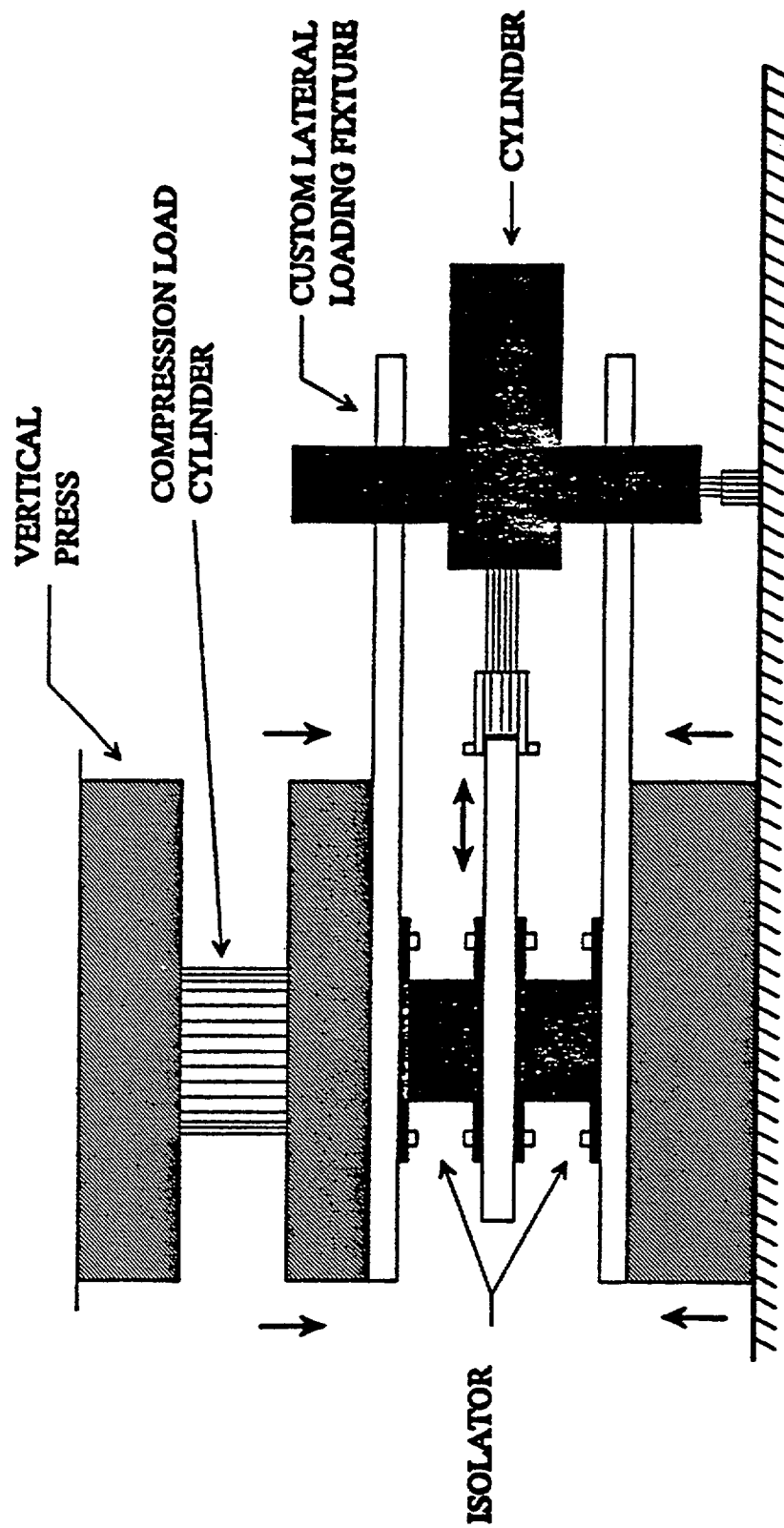

Figure C.2 Isolation Unit Test Facility, Dynamic Isolation Systems, Inc., Berkeley, California

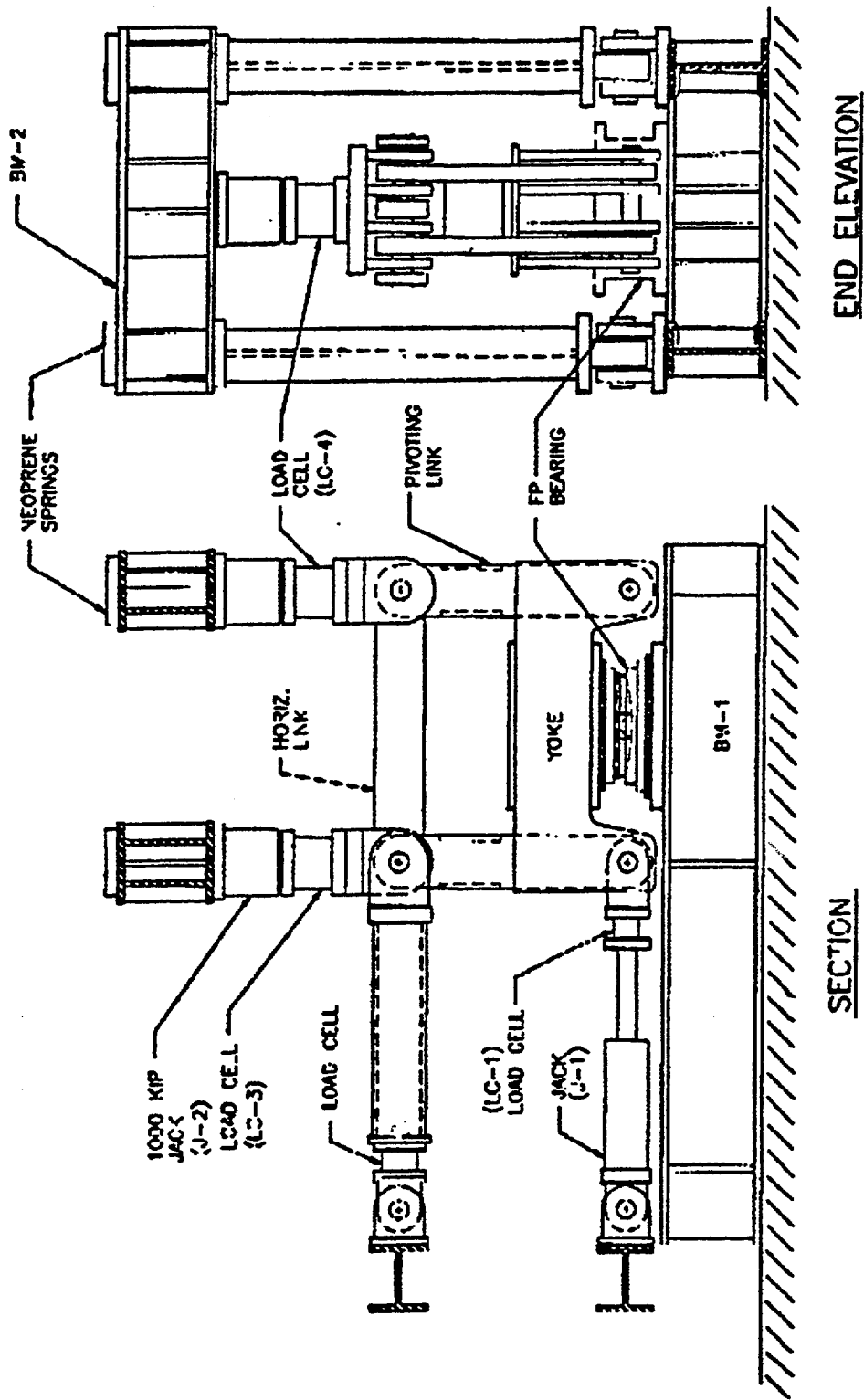

Figure C.3 Isolation Unit Test Facility, Earthquake Protective Systems, Inc., San Francisco, California

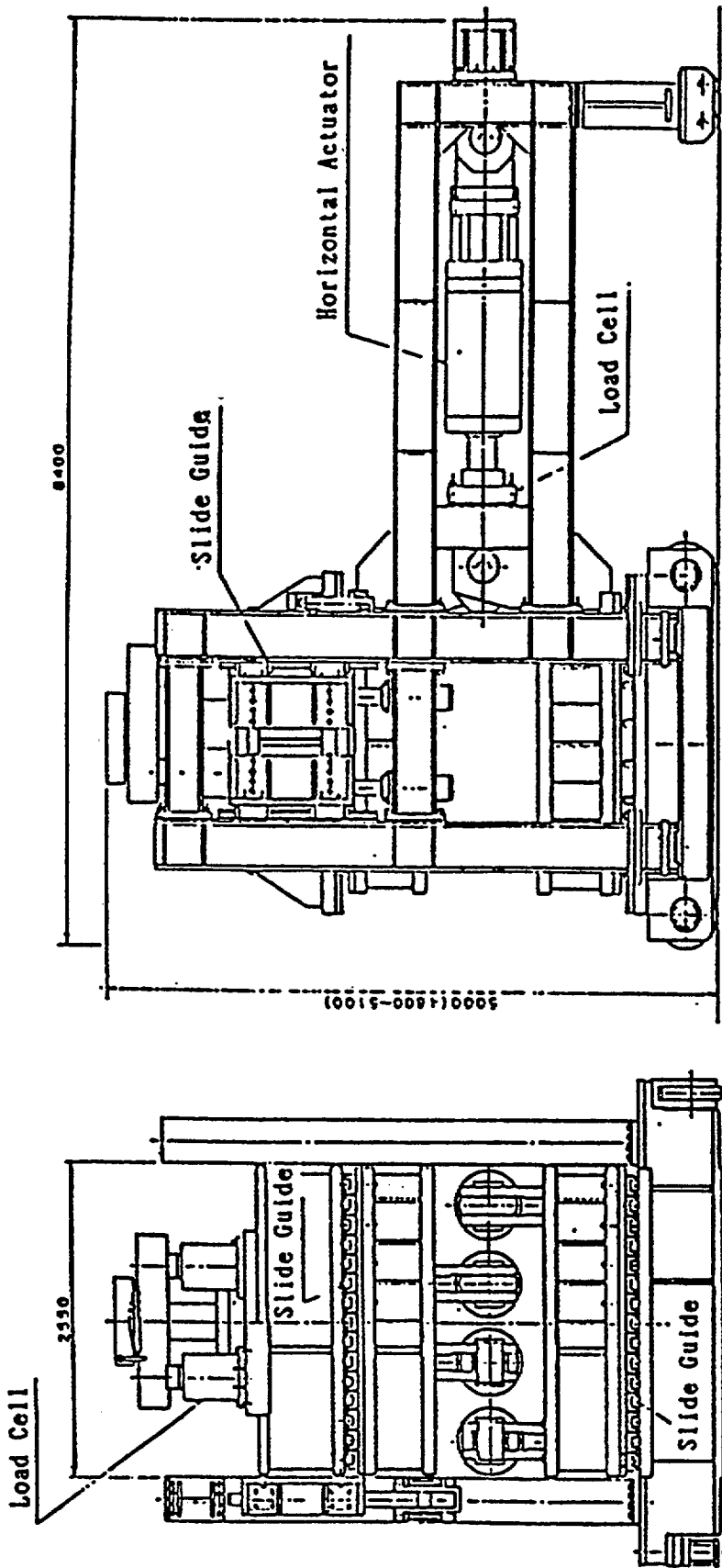

Figure C.4 Isolation Unit Test Facility, Bridgestone Corporation, Yokohama, Japan

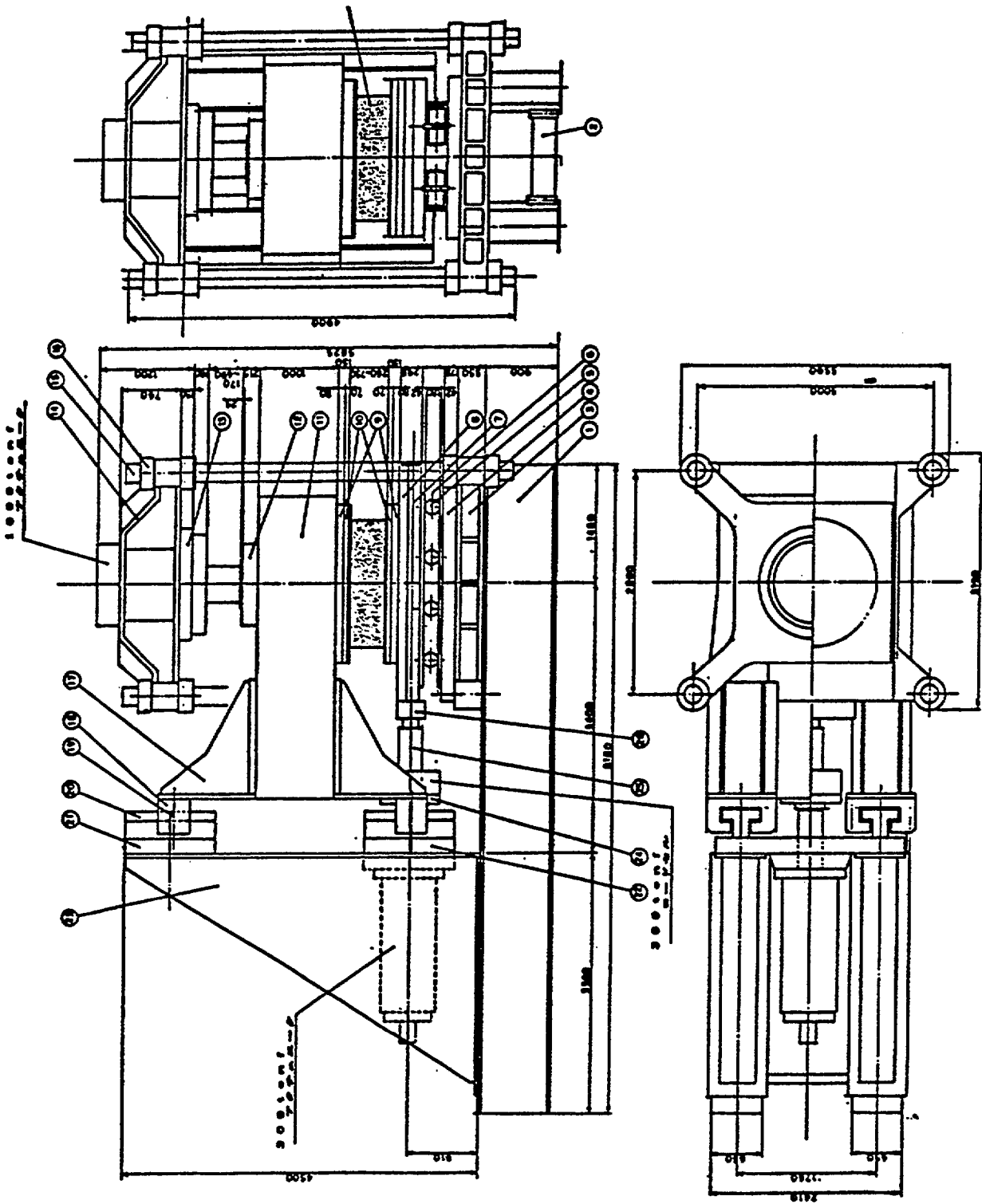

Figure C.5 Isolation Unit Test Facility, Oiles Corporation, Fujisawa, Japan



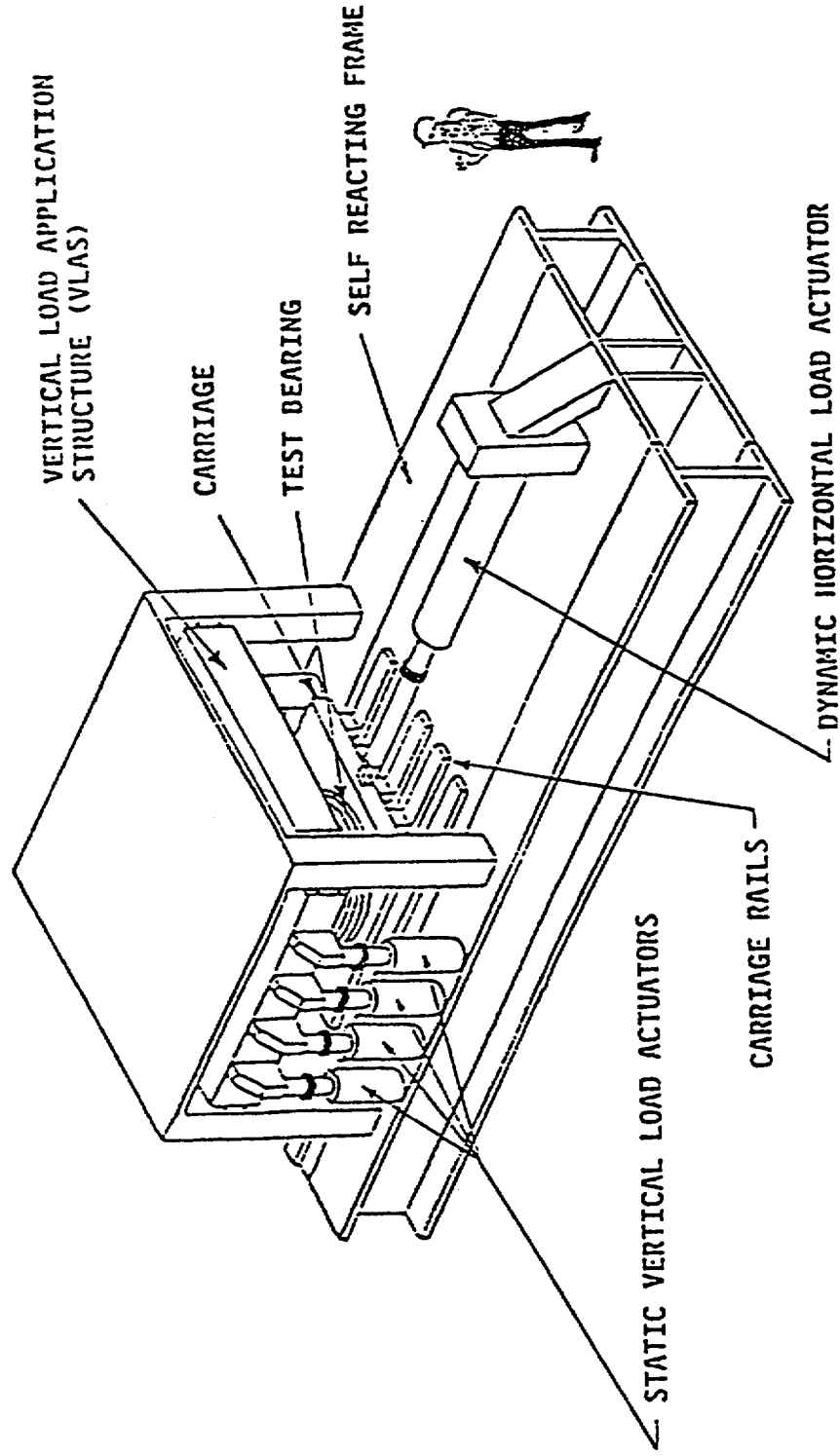

Figure C.6 Isolation Unit Test Facility, Rockwell International, Energy Technology Engineering Center (ETEC), Canoga Park, California



**APPENDIX D. DRAFT GUIDELINE FOR LONG TERM STORAGE AND TESTING OF SEISMIC ISOLATION UNITS AND COMPONENTS**

*Test*

*Designation:* VI.1

*Purpose:* To monitor the long term performance of the isolation system using production specimens stored near the isolation interface.

*Sequence:*

- a.) Procure 5 replicate specimens of an Isolation Unit (Component), of a typical size and capacity used in the isolated structure. The specimens are to be production Units (Components), manufactured to the same quality as the Units (Components) installed in the isolated structure.
- b.) Designate the 5 specimens A, B, C, D and E.
- c.) Test all 5 specimens in accordance with the prototype procedures in Chapter 6 of the Guidelines.
- d.) For Units (Components) that are designed to carry vertical load, provide a fixture for applying and maintaining a compressive load while the specimen is in storage. Apply a vertical compressive load equal to  $P_D$  to the specimen.
- e.) Store the 5 specimens near the isolation interface of the structure. The environment and conditions in which the specimens are stored should be identical to the environment and conditions of the isolation interface.
- f.) Remove the designated specimen from storage and test it in accordance with the prototype procedures in Chapter 6 of the Guidelines. The schedule for testing the five specimens is presented below:

Schedule for Testing Stored Specimens

Specimen	Years from Date of Storage
A	1
B	2
C	5
D	10
E	20

*Procedure:* Conduct the tests in accordance with the procedures described in Chapter 6. Whenever possible, the vertical load on the stored specimen shall be maintained until after completing the first prototype test, III.1.

*Criteria:* None

*Special*

*Requirements:* Report of results: A report shall be issued at the start of the long term storage program. Updated reports shall be issued after each of the stored specimens is tested. The reports shall include, as a minimum, the following:

(1.) the Average Effective Stiffness and Average Energy Dissipation of all five specimens from the initial tests conducted before the Units (Components) are stored.

(2.) the Average Effective Stiffness of each stored specimen, and the percent difference relative to the Average Effective Stiffness of the specimen at the start of the long term storage program, as given by

$$\frac{|K_H^S - K_H|}{K_H} \times 100 \quad (D.1)$$

where  $K_H^S$  is the Average Effective Stiffness of the stored specimen and  $K_H$  is the Average Effective Stiffness of the same specimen at the start of the storage program.

(3.) the Average Energy Dissipation of each stored specimen, and the percent difference relative to the Average Energy Dissipation of the specimen at the start of the long term storage program, as given by

$$\frac{|E_H^S - E_H|}{E_H} \times 100 \quad (D.2)$$

where  $E_H^S$  is the Average Energy Dissipation of the stored specimen and  $E_H$  is the Average Energy Dissipation of the same specimen at the start of the storage program.