

NIST
PUBLICATIONS

NISTIR 5345

Draft Guidelines for Quality Control Testing of Elastomeric Seismic Isolation Systems

Harry W. Shenton III

Building and Fire Research Laboratory
Gaithersburg, Maryland 20899

QC

100

.U56

#5345

1994

NIST

United States Department of Commerce
Technology Administration
National Institute of Standards and Technology

Draft Guidelines for Quality Control Testing of Elastomeric Seismic Isolation Systems

Harry W. Shenton III

February, 1994
Building and Fire Research Laboratory
National Institute of Standards and Technology
Gaithersburg, MD 20899



U.S. Department of Commerce
Ronald H. Brown, *Secretary*
Technology Administration
Mary L. Good, *Under Secretary for Technology*
National Institute of Standards and Technology
Arati Prabhakar, *Director*

ABSTRACT

Seismic isolation systems designed according to the 1991 *Uniform Building Code*, or the 1991 *AASHTO Guide Specification for Seismic Isolation Design* are required to undergo a series of prototype and quality control tests before being installed in the structure. At the present time standards do not exist for conducting these tests and results are subject to unknown variability. The document represents the initiation of the process to develop standards for quality control testing of seismic isolation systems built in the U.S. The guidelines are devoted specifically to quality control testing of elastomeric systems. The guidelines address material and component tests to be conducted during production, and tests on completed isolation units. Nine production tests are specified in the guidelines. Three completed isolation unit tests are outlined: sustained compression, compression stiffness, and effective stiffness and energy dissipation. Complete details of the test set-up, test procedure, data acquisition, analysis and reporting of results are given in the guidelines. Performance criteria are established for all tests, systems that do not meet these criteria may not perform satisfactorily in service and should be set aside for disposition by the engineer of record.

Acknowledgements

The author would like to thank the NIST Oversight Committee for their guidance and assistance in developing these guidelines. This includes Dr. Ian Buckle, Dr. Charles Kircher, Professor James M. Kelly, Dr. Ronald Mayes and Dr. Victor A. Zayas. Their time and effort are greatly appreciated.

TABLE OF CONTENTS

ABSTRACT	iii
TABLE OF CONTENTS	v
LIST OF FIGURES	vi
1. INTRODUCTION	1
1.1 Background	1
1.2 Definitions	2
1.3 Scope	3
1.4 Outline of the Report	3
2. RATED CAPACITY	5
3. PRODUCTION TESTS	7
3.1 General	7
3.2 Test Specimens	7
3.3 Test Schedule	7
3.4 Report of Results	8
4. COMPLETED ISOLATION UNIT TESTS	9
4.1 General	9
4.2 Sustained Compression	9
4.3 Compression Stiffness	11
4.4 Effective Stiffness and Energy Dissipation	15
5. SUMMARY	21
REFERENCES	23
APPENDIX A. SYMBOLS AND NOTATION	25
APPENDIX B. GLOSSARY OF TERMS	27

LIST OF FIGURES

Figure 4.1. Test Configurations	10
Figure 4.2. Definition Diagram	13

1. INTRODUCTION

1.1 Background

Seismic isolation is gradually being accepted by building owners, architects and structural engineers as a viable alternative for the design and retrofit of certain types of structures. This is due in part to the two building codes that recently adopted provisions for the design and construction of seismically isolated structures: for buildings, the *Uniform Building Code* (UBC) (*Uniform*, 1991) and for bridges, the American Association of State Highway and Transportation Officials (AASHTO), *Guide Specifications for Seismic Isolation Design* (*Guide*, 1991). The number of projects to consider seismic isolation has increased noticeably since the release of these documents.

The UBC and AASHTO Guide each rely heavily on testing of the isolation system for design and construction of isolated structures. Two class of tests are currently required by the codes: prototype tests and quality control (QC) tests. These may be loosely defined as follows:

Prototype tests are project specific and are conducted to verify the design properties of the isolation system prior to construction.

Quality Control tests are project specific and are conducted to verify the quality of manufacture and as-built properties of the isolation system prior to installation. These generally include tests conducted during fabrication (production tests) on materials or component parts of the isolation system, and tests on completed units.

A third class of tests, referred to here as Pre-Qualification tests, are defined herein as follows:

Pre-Qualification tests need not be project specific and are conducted in order to establish the fundamental properties and characteristics of the isolation system, and to determine the extent to which these properties and characteristics are dependent on load and environmental factors.

Formal pre-qualification tests as defined above are not required by the codes at the present time, but are usually conducted in some form or another as a new system is developed.

At the present time standards do not exist for conducting any of these tests. Skeleton guidelines for prototype testing are provided in the UBC and AASHTO Guide, but these amount to a simple description of the load sequence and essential parameters needed to conduct the test. The AASHTO Guide addresses quality control testing in a cursory manner. Consequently, tests conducted today, as required by the codes, are subject to unknown variability.

This document represents the initiation of the process to develop standards for quality control testing of seismic isolation systems (therefore the title "Draft Guideline..."). This report is devoted specifically to QC testing of elastomeric seismic isolation systems (defined shortly). A similar report is devoted to QC testing of sliding seismic isolation systems. Guidelines for pre-qualification and prototype testing are the subject of a third report.

The final "Guidelines..." will be published after thorough review and evaluation of the draft guidelines. The review and evaluation process is to involve broad industry input and a testing component. The completed "Guidelines.." will then be submitted to code writing organizations and regulatory agencies in consideration for adoption.

1.2 Definitions

The following definitions are intended to assist the reader in interpretation of the Guidelines:

An **Isolation System** is defined as the collection of Isolation Units, Isolation Components and all other structural elements that transfer force between the foundation/substructure and the superstructure. The Isolation System as a package provides the lateral flexibility and damping necessary for effective isolation, and high initial stiffness required to resist wind load. Some Systems also include an ultimate restraint or "fail-safe" mechanism, that is meant to engage at very large displacements or provide back-up support in case of failure of the isolation system.

An **Isolation Unit** is defined as a device that provides all the necessary characteristics of the System in an integral device.

An **Isolation Component** is defined as a device that provides some of the necessary characteristics of the System (e.g., flexibility *or* damping) in a single device.

A number of different seismic isolation systems are currently in use or under development today. The systems can, however, generally be classified as primarily elastomeric, primarily sliding or hybrid. These are briefly defined as follows:

Elastomeric systems use alternating layers of steel and elastomer, generally bonded together under high heat and pressure, to form an integral bearing that is free of joints. The laminated bearing provides the vertical stiffness, lateral flexibility and damping characteristics necessary for seismic isolation. Variations on the basic design use lead cores to provide damping in the system.

Sliding systems use two dissimilar materials to form an interface that permits relative movement between the two surfaces. Friction acts between the materials and serves to dissipate energy upon sliding. Depending on the design, an auxiliary mechanism or component is sometimes needed to provide a restoring/recentering force.

Hybrid systems generally use independent components to provide the restoring force, damping, wind restraint and ultimate restraint. Components can be integrated or in close proximity to each other, or distributed throughout the

isolation interface. Hybrid systems sometimes include aspects of one or both of the other class of systems.

A table of Symbols and Notation is contained in Appendix A. Other definitions and terms are presented in Appendix B.

1.3 Scope

The Guidelines for pre-qualification and prototype testing can, and should be independent of the type of isolation system. However, at least in part, quality control tests tend to be system specific, simply because production tests are unique to the design, materials and construction of the device. Therefore, this report is limited in scope to QC tests for elastomeric isolation systems.

The Guidelines may be applicable to certain components of a hybrid system (e.g., a laminated or solid elastomeric spring that is designed simply to provide a restoring force in the isolation system). The Guidelines should be thoroughly reviewed by the engineer to determine the applicability of particular tests.

The Guidelines are intended for systems that isolate *in the horizontal plane only*, i.e., the system is assumed to be essentially rigid in the vertical direction. Guidelines for testing of vertical isolation systems are not included. In addition, the Guidelines are intended for *passive* isolation systems only. Although it is likely that some of the tests are applicable to components of active or semi-active systems, the Guidelines were not written with these systems in mind.

The Guidelines *are not* intended to serve as a specification or manufacturing standard for elastomeric isolation units, nor are they intended to serve as a comprehensive quality control program. Rather, the guidelines outline the minimum recommended Production and Completed Unit tests that should be completed *as part of* the quality control program.

Note, the capacity of all Isolation Units must be "rated" prior to testing. The onus of responsibility is on supplier of the isolation system to report the properties and characteristics of the system. This includes specifying the range of operating loads and environmental conditions under which the system can be expected to function as designed. The concept of rated capacity is fundamental to the guidelines: the load, displacement, frequency, etc., of the test procedures are based on the rated capacity of the system. The concept of rated capacity carries through from pre-qualification, to prototype, to QC testing. A standard list of properties to be rated has been developed to cover all tests.

1.4 Outline of the Report

Presented in Chapter 2 is the list of properties and characteristics of the Unit to be rated prior to testing. Presented in Chapter 3 are guidelines for production tests. These tests are conducted on each batch of elastomer that goes into making an elastomeric Isolation Unit. Presented in Chapter 4 are Guidelines for completed unit tests. This includes three tests: sustained

compression, compression stiffness and effective stiffness and energy dissipation. A summary is presented in Chapter 5.

Although this entire document is considered "draft", certain issues and details remained to be resolved at the time of writing. In some cases these are details that pertain to a specific test, and in other cases it concerns the decision to include or exclude a particular test in its entirety. Where possible, different options, or the range of parameters that have been considered or are proposed for a particular test are presented. Draft options are preceded or enclosed in a shaded box like the one shown below:

Draft Option

2. RATED CAPACITY

The nominal capacity of all Isolation Units and Components must be "rated" by the supplier prior to testing. Properties or characteristics to be rated are listed below, along with the parameter notation and a short description.

Parameter	Notation	Description
Stiffness:		
Horizontal	K_H	Effective horizontal stiffness at the Design Displacement and Design Vertical Load.
Horizontal under Wind	K_W	Effective horizontal stiffness at the Design Wind Load and Design Vertical Load.
Vertical	K_V	Effective vertical stiffness at the Design Vertical Load.
Energy Dissipation	E_H	Energy dissipated per cycle at the Design Displacement and Design Vertical Load.
Lateral Deformation:		
Design Displacement	D	Nominal displacement capacity, including that resulting from torsion, <div style="border: 1px solid black; padding: 5px; margin-top: 5px;"> <p style="text-align: center;">Draft Option</p> <p>corresponding to a level of ground motion that has a 10 percent probability of being exceeded in a 50 year period.</p> </div>
Maximum Displacement	D_{TM}	Total maximum displacement capacity, including that resulting from torsion, <div style="border: 1px solid black; padding: 5px; margin-top: 5px;"> <p style="text-align: center;">Draft Option</p> <p>corresponding to a level of ground motion that has a 10 percent probability of being exceeded in a 100 year period.</p> </div>
Thermal Displacement	D_t	Nominal thermal displacement capacity.
Vertical Deformation:		
Design Displacement	D_V	Nominal vertical displacement under the Design Vertical Load.
Creep Displacement	D_c	Creep displacement under the Design Vertical Load.

Parameter	Notation	Description
Rotation	θ	Nominal rotation capacity about an axis in the horizontal plane, and perpendicular to the direction of lateral loading under the Design Vertical load.
Compression:		
Low	P_L	Lower limit of load range of satisfactory seismic performance, includes the effect of vertical ground motion and overturning.
Design Vertical Load	P_D	Nominal capacity in compression for dead and live load.
High	P_U	Upper limit of load range of satisfactory seismic performance, includes the effect of vertical ground motion and overturning.
Tension	P_T	Nominal capacity in tension.
Lateral Load:		
Wind	F_w	Nominal wind load capacity.
Braking/Centrifugal load	F_b	Nominal braking/centrifugal load capacity.
Degradation Cycle Limit	N_D	Number of cycles to $\pm D$ with a vertical load of P_D corresponding to a $\pm 15\%$ change in Effective Stiffness, or a $\pm 30\%$ change in Energy Dissipation relative to the first complete cycle Effective Stiffness or Energy Dissipation, respectively.
Thermal Cycle Limit	N_t	Number of cycles to $\pm D_t$ with a vertical load of P_D corresponding to a $\pm 15\%$ change in Effective Stiffness, or a $\pm 30\%$ change in Energy Dissipation relative to the first complete cycle Effective Stiffness or Energy Dissipation, respectively.
Temperature:		
Low	T_L	Lower limit of operating temperature.
Design	T_D	Nominal design temperature.
High	T_U	Upper limit of operating temperature.

3. PRODUCTION TESTS

3.1 General

This chapter outlines the requirements for production testing of elastomer used in Isolation Units. A total of nine tests are listed in the schedule. The tests are generally considered to be the recommended minimum for a typical laminated elastomeric Isolation Unit (e.g., high damping rubber or lead-rubber bearing). Note, however, the test schedule is not all inclusive, other tests may be specified by the engineer as needed.

All production tests are based on ASTM standards. For each test the relevant standard is referenced. Further details are outlined as necessary and modifications or exceptions to the standard noted. Minimum performance criteria are noted for each test and are usually based on a design specified value. These performance criteria are considered to be minimum requirements. Materials that do not meet these minimum requirements shall be rejected.

The production tests recommended in these Guidelines are similar, and in part based on the tests outlined in ASTM D 4014, *Standard Specification for Plain and Steel-Laminated Elastomeric Bearings for Bridges*: the specification may be referenced for additional information and guidance as needed. However, it should be noted that ASTM D4014 was developed for standard elastomeric bridge bearings *and not* elastomeric seismic isolation bearings. The performance criteria and performance measures in ASTM D4014 may be inappropriate for seismic isolation units.

3.2 Test Specimens

A minimum of three specimens shall be tested for all tests given in Section 3.3 to qualify the elastomer for the project, unless more are specifically required by the referenced standard. A high quality mixing process shall be used to ensure uniformity amongst different batches.

Unless otherwise specified tests shall be conducted on specimens cut from sheets or on specially molded test pieces. Tests may be conducted on specimens taken from actual bearings, at the request of the engineer. Results are to be reported as the average of the test results for the three specimens.

3.3 Test Schedule

3.3.1 Hardness - Durometer hardness shall be determined in accordance with ASTM D2240 and shall be within $\pm 10\%$ of that specified by the design. Tests shall be conducted using a Type A indenter.

3.3.2 Tensile Strength and Elongation at Break - Tensile properties shall be determined in accordance with ASTM D413. Ultimate tensile strength shall be equal to or greater than the

minimum tensile strength specified by the design. Elongation at break shall be equal to or greater than the elongation at break specified by the design.

3.3.3 *Bond Strength* - Bond of the elastomer to steel shall be determined in accordance with ASTM D429 Method B. Express the average peel strength in newtons per millimeter (pound-force per inch) of width. The average peel strength shall be equal to or greater than that specified by the design. The failure mode shall be at least 70% rubber tear.

3.3.4 *Compression Set* - Compression set shall be determined in accordance with ASTM D395 Method B. Unless otherwise specified by the engineer a specimen Type 1 or 2 shall be selected that is nearest in thickness to the thickness of the elastomer layer of the Isolation Unit. Specimens shall be conditioned for 22 hours at the temperature specified by the engineer. The compression set shall be less than the maximum permissible specified by the design.

3.3.5 *Low Temperature Properties* - Low temperature properties shall be determined, as necessary, in accordance with the elastomer grade rating. Properties to be determined include the following:

Low Temperature Stiffness (Hardness) - in accordance with ASTM D2240. Specimens shall be conditioned for 22 hours at the temperature specified by the engineer. The increase in hardness shall be less than the maximum permissible specified by the design.

Low Temperature Brittleness - in accordance with ASTM D2137 Method A. Specimens shall be conditioned for 3.0 ± 0.5 min at the specified temperature. None shall fail.

Low Temperature Compression Set - in accordance with ASTM D1229. The same type of specimen shall be used for low temperature compression set as is used for ambient temperature compression set. Specimens shall be conditioned for 7 days at the specified temperature. The low temperature compression set measured at 30 minutes shall be less than that specified by the design.

3.3.6 *High Temperature Aging* - High temperature aging shall be determined in accordance with ASTM D573. Specimens shall be conditioned for 7 days at the specified temperature. The change in durometer hardness (Type A), relative to the unaged hardness, shall be less than the maximum permissible specified by the design. The change in tensile strength and elongation at break, relative to the unaged values, shall be less than the maximum permissible specified by the design.

3.3.7 *Ozone Resistance* - Ozone resistance shall be determined in accordance with ASTM D1149. Tests shall be conducted using specimen type A. Specimens shall be conditioned at 20% strain and $40 \pm 2^\circ\text{C}$ ($104 \pm 4^\circ\text{F}$) for 100 hours. The ozone test partial pressure shall be 50 ± 5 MPa. On completion of testing the specimens shall be inspected using a 7x magnification lens. The ozone resistance shall be regarded as satisfactory if there are no visible cracks in the specimens.

3.4 Report of Results

Results shall be reported in a clear and concise report as specified by the referenced standard.

4. COMPLETED ISOLATION UNIT TESTS

4.1 General

This chapter outlines the requirements for quality control testing of completed Isolation Units. Three tests are required by the Guidelines: Sustained Compression, Compression Stiffness, and Effective Stiffness and Energy Dissipation. The completed Unit tests are designed to ensure quality of the manufactured product and to establish conformity, within a specified tolerance, with the specified design properties. These tests are a recommended minimum, others may be specified as needed.

Detailed requirements are outlined for each test. This includes test specimens, requirements of the test facility, instrumentation and calibration, data acquisition, test procedure, data analysis and reporting of results. Performance criteria are defined for each test and are to be evaluated based on the test results. Units that do not meet or exceed these requirements shall be set aside for disposition by the engineer of record.

Experience has shown that quality elastomeric Isolation Units can be manufactured that consistently meet or exceed the performance criteria stated in these Guidelines. Should more than 15% of the Units of a particular lot fail to meet the stated performance criteria, it is recommended that the engineer of record evaluate the available data and consider the disposition of the entire lot.

4.2 Sustained Compression

4.2.1 *Specimens* - All Isolation Units and Components manufactured shall be subject to the sustained compression test.

4.2.2 *Test Facility* - Tests shall be conducted in a facility that is capable of applying a static vertical load, continuously for up to 12 hours without interruption. Tests may be conducted in a single or dual specimen configuration, as illustrated in Figure 4.1. The vertical load capacity of the facility shall be at least 1.6 times the nominal load capacity (P_D) of the Isolation Unit(s) to be tested. The vertical load may be applied under load control or displacement control. The facility shall be capable of maintaining an average vertical load within $\pm 10\%$ of that specified at all times, for the duration of the test.

The vertical load system shall be verified in accordance with ASTM E4 to an accuracy of $\pm 5\%$. Load verification shall be carried out with the actual equipment to be used in the test. The test facility shall be verified annually, or, after repair, replacement or relocation of test facility equipment.

4.2.3 *Instrumentation and Calibration* - None.

4.2.4 *Data Acquisition* - An analog or digital data acquisition system shall be used to record vertical load for the duration of the test. Vertical load shall be recorded at least every 30 minutes.

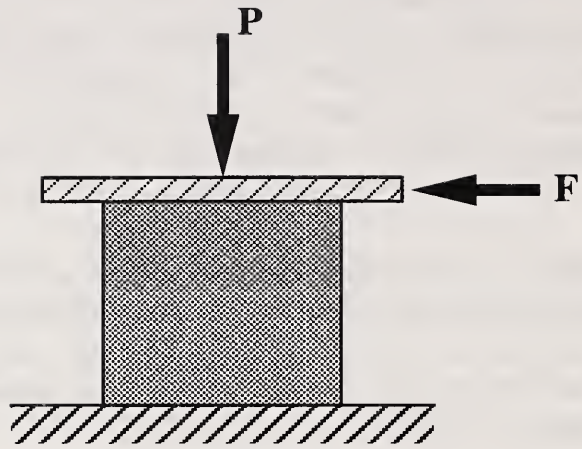

(a.) Single

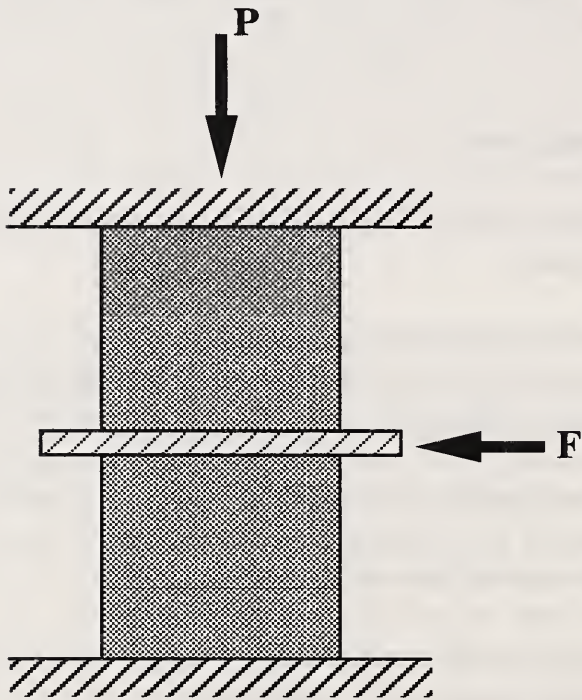

(b.) Dual

Figure 4.1. Test Configurations

A continuous-paper-feed strip chart recorder is suitable for recording vertical load.

4.2.5 *Test Procedure* - Apply a compressive load to the specimen equal to $1.5P_D$. The maximum load shall be reached within a period of not more than 10 minutes. The total load shall be maintained for 12 hours, and within $\pm 10\%$ of that specified for the duration of the test.

Exception - The duration of the test may be reduced to 3 hours, provided the supplier has documented evidence that there have been no failures, between 3 and 12 hours, in consecutive tests of at least 1000 production Units of a similar design, material and construction.

4.2.6 *Data Analysis* - From the recorded vertical load time history determine the average, maximum and minimum vertical load, between the time the total load is reached and stabilized to the end of the test.

4.2.7 *Performance Criteria* - The Isolation Unit shall be visually inspected for faults a minimum of 2 times during the test: within the first 30 minutes of testing and during the last 30 minutes of testing. The Isolation Unit shall be set aside for disposition by the engineer of record if:

- there exist 3 or more separate surface cracks that are 2 mm (0.08 in) wide and 2 mm (0.08 in) deep,
- the bulging pattern indicates a misplaced or omitted steel or elastomer layer,
- the bulging pattern indicates debonding of an elastomer and steel laminate.

The Isolation Unit shall be set aside if it fails to sustain the applied load for any reason for the duration of the test.

4.2.8 *Report of Results* - Results of the tests shall be documented in a clear and concise report. Unless otherwise specified the report should include but is not limited to the following. The name of the laboratory or institution conducting the test, name of the technician and engineer present for the test, name of the technician or engineer responsible for the test, date and time at the start of the test, test configuration (single or dual) and specimen designation. Pertinent test parameters shall be indicated in the report, including vertical load P_D , recorded average, and the maximum and minimum vertical load during testing. Indicate whether the Isolation Unit passed or failed the compression test based on the stated performance criteria. For Units that fail the test, explain in sufficient detail the reason for disposition of the Unit.

4.3 Compression Stiffness

4.3.1 *Specimens* - Twenty percent of all Isolation Units and Components manufactured in a given group or lot shall be subject to the compression stiffness test.

4.3.2 *Test Facility* - Tests shall be conducted in a facility that is capable of applying a quasi-static vertical load. Tests may be conducted in a single or dual specimen configuration, as

illustrated in Figure 4.1. The vertical load capacity of the facility shall be at least 1.5 times the nominal load carrying capacity (P_D) of the Isolation Unit(s) tested. The vertical load may be applied under load control or displacement control, provided the vertical load can be maintained within $\pm 10\%$ of a specified load for a minimum of 10 minutes.

The vertical load system shall be verified in accordance with ASTM E4 to an accuracy of $\pm 5\%$. Load verification shall be carried out with the actual equipment to be used in the test. The test facility shall be verified annually, or, after repair, replacement or relocation of test facility equipment.

4.3.3 *Instrumentation and Calibration* - Transducers shall be in place to measure, at a minimum, vertical load and vertical displacement.

Loads on the test specimen may be measured via the load read-out of the test machine, load cells in the force train or via a force transducer between the specimen and reaction support. Transducers shall be such that loads are resolved to within 1% of the specified full load. The test machine or load cells in the force train shall be verified according to ASTM E4 as described in Section 4.3.2. Other force transducers shall be calibrated periodically as described in ASTM E74 and shall have an uncertainty of not more than $\pm 2.5\%$ of force.

Vertical displacement shall be measured at 2 points on the loading plane at opposite sides of the specimen (δ_1 and δ_2 in Figure 4.2). Transducers shall be of sufficient precision to resolve the displacement to within 1% of the full displacement. Displacement transducers shall be calibrated periodically and shall have an uncertainty of not more than $\pm 2.5\%$ of displacement. Suitable displacement transducers include but are not limited to Dial Gauge, Linear Variable Differential Transformer (LVDT), Direct Current Differential Transformer (DCDT) and Linear Resistance Potentiometer.

4.3.4 *Data Acquisition* - A data acquisition system shall be selected that is compatible with the instrumentation. Continuous recording of load and displacement data during the test is not required, provided the maximum and minimum loads and maximum and minimum displacements can be recorded for each cycle at the specified frequency of loading.

4.3.5 *Test Procedure* - Condition the Isolation Unit to be tested for a minimum of 24 hours at the design temperature ($T_D \pm 6^\circ\text{C}$ (10°F)). Apply a compressive load to the specimen equal to $1.5P_D$ and maintain the load for 1 minute. The maximum load shall be reached within a period of not more than 10 minutes. Reduce the compressive load to $0.6P_D$ and maintain the load for 1 minute. Complete 3 cycles of loading between $0.6P_D$ and $1.4P_D$, at a uniform rate of loading that is in the range of 1 to 2 min/cycle. Record the maximum and minimum vertical load and the maximum and minimum vertical displacements (δ_1 , δ_2) for each of the 3 cycles.

Note - only Units of equal capacity and design vertical stiffness shall be tested simultaneously in a dual specimen configuration.

4.3.6 *Data Analysis* - The vertical displacement of the Isolation Unit (δ) for any load shall be computed as the average of the measured vertical displacements (δ_1 , δ_2), i.e.,

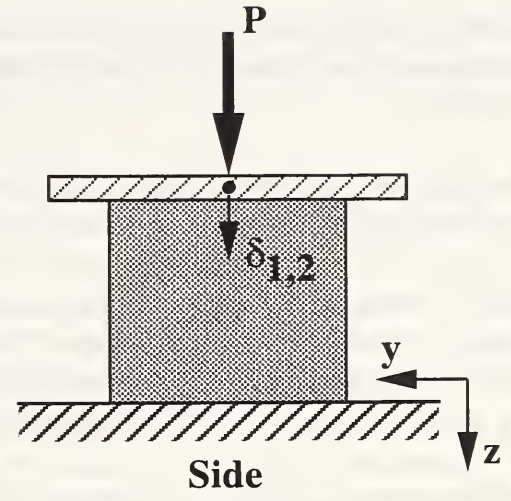
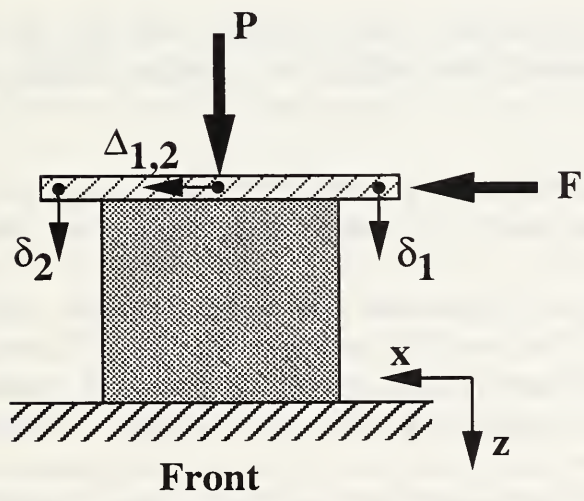
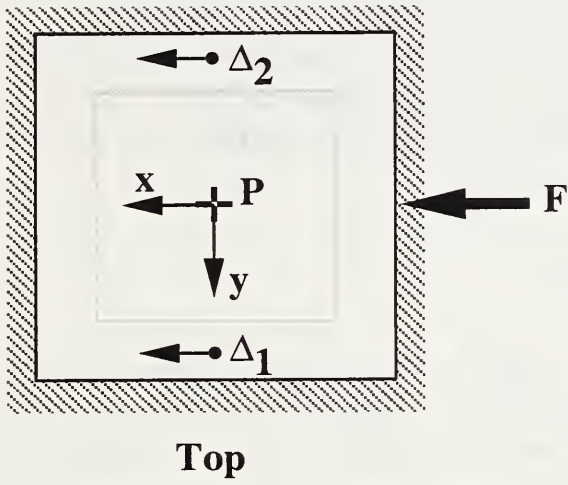

Figure 4.2. Definition Diagram

$$\delta(t) = \frac{1}{2}(\delta_1(t) + \delta_2(t)) \quad (4.1)$$

The Effective Vertical Stiffness (K_{V_i}) for each cycle i shall be computed as follows,

$$K_{V_i} = \frac{P^+ - P^-}{\delta^+ - \delta^-} \quad (4.2)$$

in which P^+ and P^- correspond to the maximum and minimum vertical load, respectively, for cycle i , and δ^+ and δ^- correspond to the maximum and minimum vertical displacement, respectively, for cycle i . The Average Effective Vertical Stiffness (K_V) shall be computed for the 3 cycles of the test, as given by

$$K_V = \frac{1}{3} \sum_1^3 K_{V_i} \quad (4.3)$$

4.3.7 *Performance Criteria* - The Isolation Unit shall be set aside for disposition by the engineer of record if the Average Effective Vertical Stiffness differs by more than $\pm 20\%$ from the average of the Average Effective Vertical Stiffnesses of all Isolation Units of a similar design and capacity, i.e., the Unit must satisfy the following:

$$\frac{|K_V - K_{V_{AVE}}|}{K_{V_{AVE}}} \leq 0.20 \quad (4.4)$$

in which K_V is the Average Effective Vertical Stiffness of a particular Unit and $K_{V_{AVE}}$ is the average of the Average Effective Vertical Stiffnesses of all Units of a similar design and capacity.

For lots of 4 or fewer, due to the low sample size, it is the responsibility of the engineer of record to decide the acceptance of individual Units based on a review of all available test data.

4.3.8 *Report of Results* - Results of the tests shall be documented in a clear and concise report. Unless otherwise specified the report should include but is not limited to the following. The name of the laboratory or institution conducting the test, name of the technician and engineer present for the test, name of the technician or engineer responsible for the test, date and time at the start of the test, test configuration (single or dual) and specimen designation. Pertinent test parameters shall be noted in the report, including the target vertical loads ($0.6P_D$ and $1.4P_D$), rate of loading and design temperature T_D . For each of the 3 cycles indicate the maximum and minimum vertical loads, maximum and minimum vertical displacements and Effective Vertical Stiffness (K_{V_i}). Indicate the Average Effective Stiffness (K_V) for the 3 cycles and the average of the Average Effective Stiffnesses ($K_{V_{AVE}}$) of all Units of a similar design and capacity. Indicate whether the Isolation Unit passed or failed the compression stiffness test based on the stated performance criteria. For Units that fail the test explain in sufficient detail the reason for disposition of the Unit.

4.4 Effective Stiffness and Energy Dissipation

4.4.1 Specimens -

Draft Option

1. All Isolation Units manufactured shall be subject to the Effective Stiffness and Energy Dissipation test.
2. If the Effective Stiffness of any Isolation Unit measured during prototype testing varies by more than 15% from the rated Effective Stiffness (K_H), or the Energy Dissipation of any Isolation Unit measured during prototype testing varies by more than 30% from the rated Energy Dissipation (E_D), then all Isolation Units manufactured shall be subject to the Effective Stiffness and Energy Dissipation tests as specified below.
3. A minimum of 20% of all Isolation Units manufactured in any lot shall be subject to the Effective Stiffness and Energy Dissipation test specified below. If the Effective Stiffness of any Isolation Unit measured in these tests varies by more than 15% from the rated Effective Stiffness (K_H), or the Energy Dissipation of any Isolation Unit measured in these tests varies by more than 30% from the rated Energy Dissipation (E_D), then all Isolation Units manufactured shall be subject to the Effective Stiffness and Energy Dissipation tests as specified below.

For Systems that consist of some combination of Units and Components, at least one set of tests shall be conducted on the combined System. The assembly and connection of the tested components shall be representative of the full System detail.

4.4.2 *Test Facility* - Tests shall be conducted in a facility that is capable of applying simultaneously a static vertical load and a cyclic lateral load to a specimen or group of specimens. Tests may be conducted in a single or dual specimen configuration, as illustrated in Figure 4.1. The vertical load capacity of the facility shall be at least 1.1 times the nominal load capacity (P_D) of the Isolation Unit(s) tested. The test facility shall have a lateral load capacity which is at least 1.1 times the largest lateral load to be applied during the test, and a total stroke of at least twice the maximum displacement specified for the test.

The cyclic lateral load shall be applied under displacement control such that the motion of the actuator is representative of a sinusoidal wave with specified frequency. The lateral load may be applied with constant velocity, such that the motion of the actuator is representative of a sawtooth wave with specified frequency, at load rates less than or equal to 250 mm/min (10 in/min). The vertical load may be applied under load control or displacement control. The facility shall be capable of maintaining an average vertical load within $\pm 10\%$ of that specified at all times, for the duration of the test. The facility shall be such that the lateral load plane will remain parallel to within $\pm 5^\circ$ of the bottom and/or top reaction support at all times, for the duration of the test.

The vertical load system shall be verified in accordance with ASTM E4 to an accuracy of $\pm 5\%$. The lateral load system shall be verified in accordance with ASTM E4 to an accuracy of $\pm 2.5\%$, or, calibrated as described in ASTM E74 and shall have an uncertainty of not more than $\pm 2.5\%$ of force. Load verification or calibration shall be carried out with the actual equipment to be used in the test. The test facility shall be verified or calibrated annually, or, after repair, replacement or relocation of test facility equipment.

4.4.3 *Instrumentation and Calibration* - Transducers shall be in place to measure, at a minimum, vertical load, lateral load and lateral displacement.

Vertical and lateral loads on the test specimen may be measured via the load read-out of the test machine, load cells in the force train or via a force transducer between the specimen and reaction support. Transducers shall be such that loads are resolved to within 1% of the specified full load. Load cells measuring vertical or lateral load in the force train of the actuator shall be verified or calibrated as described in Section 4.4.2. Other force transducers shall be calibrated periodically as described in ASTM E74 and shall have an uncertainty of not more than $\pm 2.5\%$ of force.

Lateral displacement shall be measured at 2 points on the lateral load plane, at opposite sides of the specimen (Δ_1 and Δ_2 , in Figure 4.2). Transducers shall be of sufficient precision to resolve the displacement to within 1% of the full displacement. Displacement transducers shall be calibrated periodically and shall have an uncertainty of not more than $\pm 2.5\%$ of displacement. Suitable displacement transducers include but are not limited to Linear Variable Differential Transformer (LVDT), Direct Current Differential Transformer (DCDT) and Linear Resistance Potentiometer.

4.4.4 *Data Acquisition*- An analog or digital data acquisition system shall be used to record time, vertical load, lateral load and two lateral displacements for the duration of the test. Data shall be digitized or sampled at a rate not less than 100 times the frequency of loading. A digital data acquisition system shall be capable of sampling all data channels nearly simultaneously: the maximum time skew between channels shall be less than 1% of the sampling time interval.

4.4.5 *Test Procedure* - Condition the Isolation Unit for a minimum of 24 hours at the design temperature ($T_D \pm 6^\circ\text{C}$ (10°F)). Place the Isolation Unit(s) in the test machine and secure as needed to the loading plates. Apply a compressive load to the specimen equal to P_D and allow the load to stabilize. The total load shall be applied within a period of not more than 2 minutes.

Draft Option

1. Apply a cyclic lateral load to the specimen for (option: 3 or 5) fully reversed cycles, to peak displacements of $\pm D$. The frequency of lateral loading shall be not less than f_L (the lower threshold frequency¹) or 0.004 cyc/sec.
2. Apply a cyclic lateral load to the specimen for (option: 3 or 5) fully reversed cycles, to peak displacements of $\pm D$ or $\pm 100\%$ shear strain (a displacement corresponding to the total thickness of elastomer of the Unit), which ever is greater. The frequency of loading shall be not less than 0.004 cyc/sec.

The test shall be run continuously without pause between cycles. The compressive load shall be maintained such that the average load is within $\pm 10\%$ of P_D and the maximum and minimum loads are within $\pm 20\%$ of P_D for the duration of the test.

4.4.6 *Data Analysis* - The time history of lateral displacement (Δ) shall be computed as the average of the measured lateral displacements (Δ_1, Δ_2), i.e.,

$$\Delta(t) = \frac{1}{2}(\Delta_1(t) + \Delta_2(t)) \quad (4.5)$$

Hysteresis loops for lateral deformation shall be constructed by plotting the measured lateral load (F) versus the lateral displacement (Δ) for the (3 or 5) complete cycles of the test. The maximum and minimum lateral displacements, Δ^+ and Δ^- respectively, shall be established for each cycle. The maximum and minimum lateral loads, F^+ and F^- respectively, shall be established for each cycle. Effective Stiffness (K_{H_i}) for each cycle i shall be computed as follows,

$$K_{H_i} = \frac{F^+ - F^-}{\Delta^+ - \Delta^-} \quad (4.6)$$

The Average Effective Stiffness (K_H) shall be computed for the (3 or 5) complete cycles of the test, as given by

$$K_H = \frac{1}{(3 \text{ or } 5)} \sum_1^{(3 \text{ or } 5)} K_{H_i} \quad (4.7)$$

¹The lower threshold frequency f_L is evaluated as described in "Draft Guidelines for Pre-Qualification and Prototype Testing of Seismic Isolation Systems," (Shenton, 1993). Tests conducted at rates less than f_L do not yield results that are representative of the behavior expected during an actual seismic event.

Energy Dissipation shall be determined for each cycle of the test. The energy dissipated in cycle i (E_{H_i}), is equal to the area enclosed by the hysteresis loop for that cycle and should be expressed in units of force-length (e.g., kN-mm, or kip-in, etc.). The area enclosed by the loop may be determined by numerical integration for digital data, or by other suitable means for analog data. The Average Energy Dissipation (E_H) shall be determined for the (3 or 5) complete cycles of the test, as given by

$$E_H = \frac{1}{(3 \text{ or } 5)} \sum_1^{(3 \text{ or } 5)} E_{H_i} \quad (4.8)$$

4.4.7 *Performance Criteria* - The Isolation Unit shall be set aside for disposition by the engineer of record if the Average Effective Stiffness is not within $\pm 15\%$ of the average of the Average Effective Stiffnesses of all Units of a similar design and capacity, i.e., the Unit must satisfy the following:

$$\left| \frac{K_H - K_{H_{AVE}}}{K_{H_{AVE}}} \right| \leq 0.15 \quad (4.9)$$

in which K_H is the Average Effective Stiffness of a particular Unit and $K_{H_{AVE}}$ is the average of the Average Effective Stiffnesses of all Units of a similar design and capacity.

The Isolation Unit shall be set aside for disposition by the engineer of record if the Average Energy Dissipation is not within $\pm 15\%$ of the average of the Average Energy Dissipation of all Units of a similar design and capacity, i.e., the Unit must satisfy the following:

$$\left| \frac{E_H - E_{H_{AVE}}}{E_{H_{AVE}}} \right| \leq 0.15 \quad (4.10)$$

in which E_H is the Average Energy Dissipation of a particular Unit and $E_{H_{AVE}}$ is the average of the Average Energy Dissipations of all Units of a similar design and capacity.

For lots of 4 or fewer, due to the low sample size, it is the responsibility of the engineer of record to decide the acceptance of individual Units based on a review of all available test data.

4.4.8 *Report of Results* - Results of the tests shall be documented in a clear and concise report. Unless otherwise specified the report should include but is not limited to the following. The name of the laboratory or institution conducting the test, name of the technician and engineer present for the test, name of the technician or engineer responsible for the test, date and time at the start of the test, test configuration (single or dual) and specimen designation. Pertinent test parameters shall be noted in the report, including vertical load, displacement D , frequency of loading and design temperature T_D . For each of the (3 or 5) cycles indicate the maximum and minimum

lateral loads, maximum and minimum lateral displacements and Effective Stiffness (K_{H_i}). Note the Average Effective Stiffness (K_H) for the (3 or 5) cycles and the average of the Average Effective Stiffnesses ($K_{H_{AVE}}$) of all Units of a similar design and capacity. Indicate the Energy Dissipation (E_H) for each cycle and the Average Energy Dissipation (E_H) over (3 or 5) cycles. Note the average of the Average Energy Dissipations ($E_{H_{AVE}}$) of all Units of a similar design and capacity. Indicate whether the Isolation Unit passed or failed the test based on the stated performance criteria. For Units that fail the test explain in sufficient detail the reason for disposition of the Unit.

5. SUMMARY

The 1991 *Uniform Building Code* and the 1991 *AASHTO Guide Specification for Seismic Isolation Design* require that all isolation units designed in the United States undergo a series of quality control tests before installation. At the present time, however, standards do not exist for conducting these tests. This report represents the first step in the effort to develop standards for quality control testing of elastomeric seismic isolation systems.

Guidelines have been presented for conducting production tests and tests on completed isolation units. Nine production tests have been outlined that are to be conducted on the elastomer used in the fabrication of an isolation unit. Materials that do not meet or exceed the recommended performance measures should be rejected. Three completed unit tests have been outlined in the Guidelines: sustained compression, compression stiffness, and effective stiffness and energy dissipation. Detailed requirements of the test facility, test procedure, instrumentation, data acquisition, data analysis and reporting of results have been provided. Completed units that do not meet or exceed the stated performance criteria should be set aside for disposition by the engineer of record.

The tests outlined in the Guidelines are a recommended minimum and should be adopted as part the manufacturers overall quality control program. They have been developed to ensure a minimum level of quality and acceptable performance of seismic isolation systems.

REFERENCES

ASTM D395, Standard Test Methods for Rubber Property - Compression Set.

ASTM D412, Standard Test Methods for Rubber Properties in Tension.

ASTM D429, Standard Test Methods for Rubber Property - Adhesion to Rigid Substrates.

ASTM D573, Standard Test Method for Rubber - Deterioration in a Air Oven.

ASTM D1149, Standard Test Method for Rubber Deterioration - Surface Ozone Cracking in a Chamber.

ASTM D1229, Standard Test Method for Rubber Property - Compression Set at Low Temperatures.

ASTM D1349, Standard Practice for Rubber - Standard Temperatures for Testing.

ASTM D2137, Standard Test Methods for Rubber Property - Brittleness Point of Flexible Polymers and Coated Fabrics.

ASTM D2240, Standard Test Method for Rubber Property - Durometer Hardness.

ASTM D4014, Standard Specification for Plain and Steel-Laminated Elastomeric Bearings for Bridges.

ASTM E4, Standard Practices for Load Verification of Testing Machines.

ASTM E74, Standard Practice of Calibration of Force-Measuring Instruments for Verifying the Force Indication of Testing Machines.

ASTM E177, Standard Practice for Use of the Terms Precision and Bias in ASTM Test Methods.

Guide Specifications for Seismic Isolation Design (1991), American Association of State Highway and Transportation Officials, Washington, D.C.

Shenton, H.W., 1993, "Draft Guidelines for Pre-Qualification and Prototype Testing of Seismic Isolation Systems," NISTIR 5359, National Institute of Standards and Technology, Gaithersburg, Maryland.

Uniform Building Code (1991), International Conference of Building Officials, Whittier, California.

APPENDIX A. SYMBOLS AND NOTATION

The symbols and notation below apply to the guidelines outlined in this document:

- D = Design Displacement;
- D_c = Creep displacement;
- D_{TM} = Total maximum displacement;
- D_t = Thermal displacement;
- D_v = Vertical displacement;
- E_H = Average Energy Dissipation;
- $E_{H_{AVE}}$ = average of the Average Energy Dissipations of several Units of a similar design and capacity;
- E_{H_i} = Energy Dissipation for cycle i ;
- f_i = isolation frequency and the inverse of the isolation period (T_i);
- f_L, f_U = lower and upper threshold frequencies, between which the measured response is within a prescribed percentage of the response measured at a frequency of f_i ;
- F = lateral load;
- F^+, F^- = maximum lateral load ($\max\{F\}$) for a single cycle, minimum lateral load ($\min\{F\}$) for a single cycle;
- F_B = lateral load due to braking or centrifugal forces;
- F_W = wind load;
- K_H = Average Effective Stiffness;
- $K_{H_{AVE}}$ = average of the Average Effective Stiffnesses of several Units of a similar design and capacity;
- K_{H_i} = Effective Stiffness for cycle i ;
- K_V = Average Effective Vertical Stiffness at the Design Vertical Load;
- $K_{V_{AVE}}$ = average of the Average Effective Vertical Stiffnesses of several Units of a similar design and capacity;
- K_{V_i} = Effective Vertical Stiffness for cycle i ;
- K_W = Effective Stiffness at the Design Wind Load;
- N_D = degradation cycle limit;
- N_t = thermal cycle limit;
- P = vertical load;

P_L	=	low vertical load;
P_D	=	design vertical load;
P_T	=	tensile load;
P_U	=	high vertical load;
t	=	thickness of elastomer layer;
T_i	=	isolation period;
T_L	=	low temperature;
T_D	=	design temperature;
T_U	=	high temperature;
Δ	=	lateral displacement;
Δ^+, Δ^-	=	maximum lateral displacement ($\max\{\Delta\}$) for a single cycle, minimum lateral displacement ($\min\{\Delta\}$) for a single cycle;
Δ_1, Δ_2	=	measured lateral displacements;
δ	=	vertical displacement;
δ^+, δ^-	=	maximum vertical displacement ($\max\{\delta\}$) for a single cycle, minimum vertical displacement ($\min\{\delta\}$) for a single cycle;
δ_1, δ_2	=	measured vertical displacements;
θ	=	lateral load plane rotation.

APPENDIX B. GLOSSARY OF TERMS

The definitions below apply to the guidelines outlined in this document:

Average Effective Stiffness	The average of the Effective Stiffnesses over a number of cycles for a specified set of test conditions.
Average Energy Dissipation	The average of the Energy Dissipation over a prescribed number of cycles for a specified set of test conditions.
Effective Stiffness	Lateral force in the Isolation System, Unit or Component divided by the lateral displacement.
Energy Dissipation	The area enclosed by a single hysteresis loop.
Frequency of Load	The number of full cycles of loading completed per unit time, usually expressed as cycles/sec.
Hysteresis Loop	A curve generated by plotting force versus displacement, which under cyclic loading generally forms a loop.
Isolation Component	A flexible structural element of the Isolation System which permits large lateral deformations under seismic excitation. An Isolation Component provides primarily a restoring force or damping attribute in a single structural element. An Isolation Component may also be used as a structural member for non-seismic loads. An Isolation Component in and of itself cannot fulfill the restoring force and energy dissipation properties required of the System.
Isolation System	The collection of structural elements that includes all individual Isolation Units, Components, other structural members and connections that transfer force between the substructure and superstructure and form the isolation interface. The Isolation System also includes any other lateral restraint system that is utilized to resist non-seismic loads, or serves as an ultimate restraint device.
Isolation Unit	A flexible structural element of the Isolation System which permits large lateral deformations under seismic excitation. An Isolation Unit provides all restoring force and damping attributes in a single integrated structural element. An Isolation Unit may also be used as a structural member for non-seismic loads.
Isolation Interface	The boundary between the upper portion of the structure (superstructure) which is isolated, and the lower portion of the structure (substructure) which is not isolated.
Precision	A "generic concept related to the closeness of agreement between test results obtained under prescribed like conditions from the measurement process being evaluated" (ASTM E 177-90a).

Rate of Load	The velocity of the actuator or load fixture expressed as distance per unit time.
Uncertainty	A statistical estimate of the error limits of a quantity obtained from a calibration equation (ASTM E 74-91).

