



A11104 121418

NIST
PUBLICATIONS



United States Department of Commerce
Technology Administration
National Institute of Standards and Technology

NISTIR 5006

**NIST MEASUREMENT SERVICE FOR
ELECTROMAGNETIC CHARACTERIZATION
OF MATERIALS**

J.H. Grosvenor

QC
100
.U56
#5006
1993

NISTIR 5006

NIST MEASUREMENT SERVICE FOR ELECTROMAGNETIC CHARACTERIZATION OF MATERIALS

J.H. Grosvenor

Electromagnetic Fields Division
Electronics and Electrical Engineering Laboratory
National Institute of Standards and Technology
Boulder, Colorado 80303-3328

August 1993



U.S. DEPARTMENT OF COMMERCE, Ronald H. Brown, Secretary
NATIONAL INSTITUTE OF STANDARDS AND TECHNOLOGY, Arati Prabhakar, Director

NIST MEASUREMENT SERVICE FOR ELECTROMAGNETIC CHARACTERIZATION OF MATERIALS

John H. Grosvenor
Antenna and Materials Group
Electromagnetic Fields Division
National Institute of Standards and Technology
Boulder, Colorado 80303-3328

This paper presents an overview of the special test/measurement services currently available at the National Institute of Standards and Technology for characterizing the dielectric and magnetic properties of materials at the rf and microwave frequencies. Many important applications of materials used throughout the electronics, microwave, aerospace, and communications industries, have created a significant and increased need for reliable data on the electromagnetic properties of such materials. This paper emphasizes recent improvements in metrology capabilities developed at NIST. These include the broadband (0.1 MHz to 18 GHz) transmission-line techniques and low-frequency parallel-plate capacitor methods. The paper also briefly addresses other facets of the NIST program, including the provision of dielectric and magnetic reference materials to customers and the organization of national round robin intercomparisons.

Key words: microwave measurements, coaxial transmission line, cavity resonator, waveguide, intercomparison, dielectric constant, permittivity, permeability, capacitors.

I. INTRODUCTION

The Electromagnetic Properties of Materials (EPM) Project was reinstated at the National Institute of Standards and Technology (NIST) in 1987 after being inactive for many years, in response to industry needs. Since that time, the project has developed measurement capabilities, using various techniques to measure the permittivity and permeability of materials over many frequency bands. This paper gives an overview of our current measurement capabilities and discusses future areas of work including high-temperature superconducting (HTS) materials metrology [1-29].

II. AUTOMATIC NETWORK ANALYZERS

The NIST EPM project uses three automatic network analyzers (ANA's) that cover the frequency range from 100 kHz to 26.5 GHz. A low-frequency network analyzer measures from 5 Hz to 100 kHz for one-port measurements and from 100 kHz to 500 MHz for two-port measurements. The mid-range network analyzer operates from 300 kHz to 6 GHz, which is the frequency range most often requested for magnetic

materials. The high-range network analyzer operates from 45 MHz to 26.5 GHz. Semi-rigid cables are used for adequate phase stability. Full two-port calibrations are used for most coaxial measurements. These calibrations are then checked to ensure that the calibration is within 0.2° of phase variation through a 10 cm long air line. Thru-reflect-line (TRL) calibrations are used for waveguide measurements. These calibrations are also checked to ensure that the calibration is within 0.1° of phase variation through a 25.4 mm long waveguide.

III. MEASUREMENT FIXTURES

Coaxial transmission lines are one of the more popular measurement methods because they allow broadband measurements of materials. This technique gives approximately 5% accuracy for low- to medium- permittivity materials. Currently, three types of coaxial transmission line fixtures are used to make measurements of materials. The most widely used is the 7 mm coaxial airline with a frequency range from dc up to about 18 GHz. One of the problems with this air line is that the air gap to material size ratio is so large that serious inaccuracy results when measuring high-dielectric materials. Figure 1 shows there is an air gap that exists between the inner conductor and the sample's inner diameter and another air gap between the outer conductor and the sample's outer diameter.

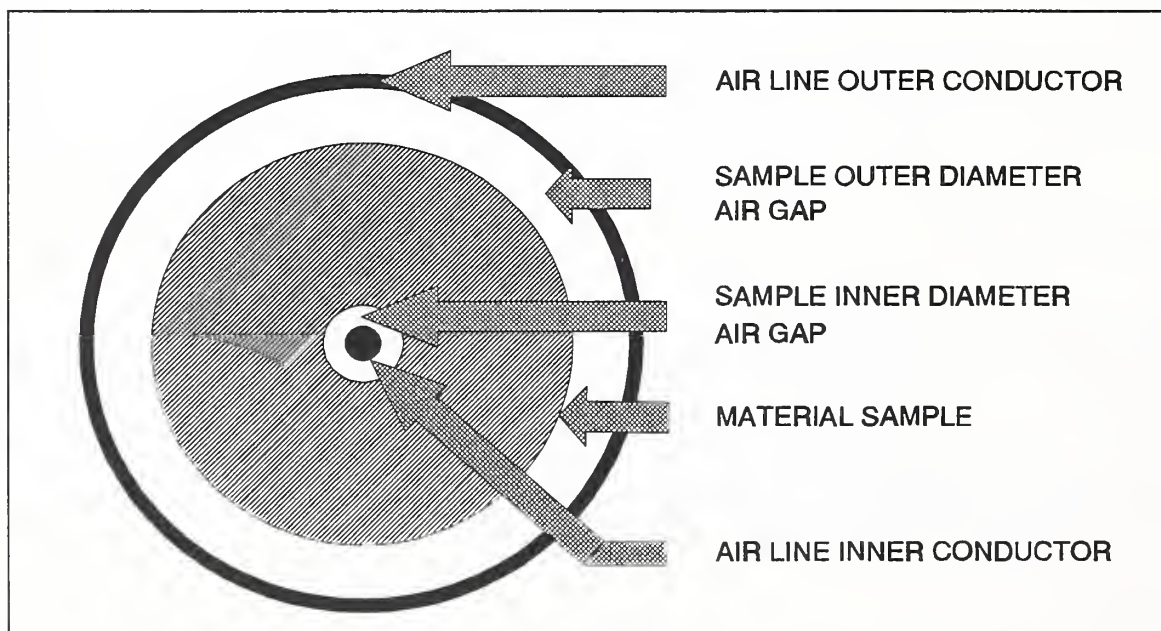

Figure 1. Coaxial material sample.

This air gap will make the measurement lower than the actual dielectric constant of the material. To help alleviate this problem we also measure materials using a 14 mm air line. Not only are the measurements more accurate, because of the reduced air gap to material ratio, but it is also easier to machine the samples for this fixture. The 14 mm air line is used up to 2 GHz, which is the limit of our in-house calibration kit. To reduce air-gap error further, we designed and fabricated the various standards and air lines required for an 79.4 mm (3 1/8 in) coaxial standard and sample holder. With these standards, we developed a TRL calibration kit for our ANA, but were able to get a good calibration only up to 600 MHz. We think that this is probably due to connector inadequacies, since the connectors were designed primarily for handling high-rf power and cannot be considered precision connectors [1-4].

In order to show how the air gap affects the measurement results, the following table shows the dependence of measured dielectric constants (ϵ') on an air gap of 0.0254 mm (0.001 in) for different coaxial lines.

Table 1. Measurement of three materials using different coaxial lines.

Coaxial line size (mm)	ϵ'_{meas} ($\epsilon'_{\text{actual}} = 10$)	ϵ'_{meas} ($\epsilon'_{\text{actual}} = 100$)	ϵ'_{meas} ($\epsilon'_{\text{actual}} = 1000$)
3.0	7.94	26.06	33.8
7.0	8.85	41.29	67.1
14.0	9.39	58.42	122.2
25.0	9.65	71.49	199.0
41.2	9.78	80.52	290.5
79.4	9.88	88.80	440.8

In addition to coaxial measurement capabilities, two types of waveguide systems are used for measurements. The most widely used waveguide is the X-band, or WR-90 waveguide, which covers the frequency range from 8.2 GHz to 14.2 GHz. Waveguide measurements are relatively easy to make and duplicate by others. In response to requests for S-band measurements, we have also developed a measurement capability using the WR-284 waveguide. The frequency range of this waveguide is from 2.6 GHz to 3.95 GHz. Again, the greater the diameter, the less the effect of the air gap on the measurement. The reduced air gap results in higher accuracies, which are approximately 2 to 3% for waveguide measurements.

Resonators are used for an accurate measurement of the loss tangents (ϵ''/ϵ'). Currently, three fixtures are used for measurements and two fixtures are being fabricated. The first resonant fixture was an X-band mode-filtered, cylindrical, 60 mm cavity. It was designed for measurements at 10 GHz and operates between 9 GHz and 11 GHz. The quality factor (Q) of this resonator is around 80 000. This cavity operates in the TE_{01n} mode, which gives very accurate measurements, both of the dielectric constant and the loss tangent over a narrow band. The accuracy of this technique for permittivity measurements is within 1% [5-9].

A fixed-length stripline resonator is being developed for a fundamental frequency of 150 MHz and operation up to about 2 GHz. The quality factor at the fundamental frequency is about 4 200. It is still being developed and analyzed, but we anticipate measurement accuracies for permittivity and permeability within 5%.

A current measurement technique and fixture being evaluated involves a parallel-plate resonator, which was made under a State Department research project with Poland. The resonator is used for substrate permittivity measurements and conductor surface-resistance measurements. The measurements made, so far, typically fall between 5 GHz and 20 GHz. The frequency of resonance and the quality factor are dependent upon sample size and the sample's permittivity.

A 10 and 25 GHz sapphire resonator have been recently designed and are awaiting testing. These resonators will be used for measurements of HTS thin films. Also, we are designing a Fabry-Perot open resonator for substrate measurements at 60 GHz.

In an attempt to measure a series of very high dielectric materials, we are using several measurement devices that were developed at the former National Bureau of Standards, including several parallel-plate capacitor fixtures. These operate at fixed frequencies in the low audio-frequency range of 50 Hz, 60 Hz, 100 Hz, 120 Hz, 200 Hz, 400 Hz, 500 Hz, 1 kHz, 2 kHz, 5 kHz, and 10 kHz, and measurements are made with a capacitance bridge, a tunable filter/amplifier with a null meter and a voltmeter. Several very-high-permittivity samples have been measured with this technique [10,11].

The high-dielectric test results are cross-checked with other techniques, including the permeameter [12-17] and permittimeter techniques [18]. These techniques are used at low frequencies, which gives good preliminary results for high-permittivity material measurements. This information is used in our EPSMU3 data-reduction software package, which then reduces the measurement data at higher frequencies. A very short program called "PERMETER" was written to help automate the permeameter and permittimeter measurements with our ANA's and help with the data reduction.

Industry has requested assistance in measuring liquids and powders. We designed and have constructed several 14 mm shielded open-circuit sample holders. We have responded with several measurements using these holders [19,20].

NIST is also conducting research and development on several sizes of open-ended coaxial probes that cover various frequency ranges to determine what size of coaxial probes will work most effectively for various requirements and applications. A 3.5 mm probe, a 14 mm probe, and a 35 mm probe are being used. Most work is being done with the 3.5 mm coaxial probe, which operates from 100 MHz to 20 GHz, and the 35 mm coaxial probe, which operates from 100 MHz to 2 GHz. This is a nondestructive measurement and can have a wide range of applications [21,22]. Most other capabilities involve destructive testing, that is, coaxial and waveguide samples must be machined to fit into the appropriate sample holders.

IV. REFERENCE MATERIALS

Several materials in limited bulk supplies are available as reference materials.

Corning^{*} 1723 glass and Corning 7940 fused silica date back to the 1960's and have been well characterized. These glasses were characterized by Bussey [23,24] and were used in various intercomparisons. The 1723 glass supply is actually an old airplane window that Bussey purchased in 1965 [25].

When the materials project was reactivated, there was an immediate demand in industry and within the project for materials that had been well characterized. Such materials were needed for verification of the various fixtures being brought on line and techniques being tried and evaluated. Sheet stock of cross-linked polystyrene and 60 mm resonant cavity samples of alumina were obtained and characterized by these various techniques. Polytetrafluoroethylene (PTFE) is another material used for comparison measurements among the various techniques. However, there are slight differences in PTFE from different manufacturers, and it is thermally unstable [26].

Testing also has been done to characterize various magnetic materials that could be candidates for magnetic reference materials. At this time, it is unclear whether these materials meet the rigorous requirements for a NIST standard reference material [27].

V. ROUND-ROBIN INTERCOMPARISONS

NIST has been involved in organizing several National intercomparisons with industry. Just concluded is a dielectric round-robin intercomparison with several industry

*NOTE: Trade names used in this paper are identified to specify experimental procedures and do not imply recommendation or endorsement by NIST.

participants. Three kits containing dielectric samples were circulated among the participants. All three of the kits had four different sample materials of low- to mid-range dielectric and loss properties. The third kit, however, had an additional sample containing a high- dielectric material. The results of this dielectric round-robin intercomparison are to be published in the near future.

We have recently begun another round-robin intercomparison with several industry participants. The samples for this round robin are of magnetic materials. The samples are in both 7 mm and 14 mm sizes. A report will also be published on the data received in this intercomparison.

Preparations are being made to begin another round-robin intercomparison involving the use of a stripline resonator for measurements of both dielectric and magnetic materials. Selection of materials has been completed and the companies have been contacted.

VI. SERVICES AND PRODUCTS AVAILABLE

Presently, NIST makes available a software package called "EPSMU3" along with a users guide. This software package is based on the extended Baker-Jarvis algorithm for complex permittivity and permeability determination during transmission-line measurements. The software package allows the user to use two different types of commercially available ANA's without any additional programming. A third ANA will be added soon. The user can do some reprogramming for any other type of ANA used with the software. In its present form, the software allows the user to use six different techniques for measuring materials.

1. Transmission/reflection technique, one sample (nonmagnetic)
2. Transmission technique, one sample (nonmagnetic)
3. Short-circuited line technique, one sample (nonmagnetic)
4. Transmission/reflection technique, one sample (magnetic)
5. Transmission/reflection technique, two samples (magnetic)
/one sample position
6. Short-circuited line technique, two samples (nonmagnetic)
/two sample positions

Over the past two to three years, this package has evolved into a user-friendly package for those wishing to make material measurements without spending time and effort on the programming of computer driven ANA's [28,29].

The EPM project has available an optical machinist available for sample machining and preparation. He has been continuously working with the various materials we have in

stock, those we order and those we receive for evaluation and testing. He has developed new tooling to machine these materials into the sample geometries required for testing with the tight tolerances we require. He has worked with both soft and hard materials and can hold tolerances within about 5 to 8 μm . This service is available on request.

Dielectric and magnetic measurements are offered as a special test from 0.05 to 18 GHz. The normal sample geometries are in the form of X-band waveguide, 7 mm coaxial air line, 14 mm coaxial air line or 60 millimeter disk. We will accommodate other sample geometries, on request, provided the capabilities are available. "Bulk" materials can be machined into the required sample fixture geometry. The "NIST Calibration Services Users Guide, NIST Special Publication 250 Appendix" contains further details.

VII. CONCLUSIONS

The EPM Project has been developing newer and more accurate capabilities and fixtures for material measurements. In addition, these and other established techniques are continually being reevaluated and updated for determining the electric and magnetic properties of materials. The goal of the project is to meet the increasing demands of industry for characterizing newly developed materials, dielectric, magnetic, and HTS, and to continue to upgrade the techniques for characterizing the standard materials that are and have been used by standards laboratories in Government and industry.

VIII. REFERENCES

- [1] Baker-Jarvis, J. Dielectric and Magnetic Measurement Methods in Transmission Line: An Overview. AMTA Proc. (Chicago, IL); 1-23; 1992 July.
- [2] Domich, P.D.; Baker-Jarvis, J.; Geyer, R. Optimization Techniques for Permittivity and Permeability Determination. Natl. Inst. Stand. and Technol. NISTIR 4571; 1991 June. 17 p.
and J. Res. Natl. Inst. of Stand. and Technol. 96(5): 565-575; 1991 September-October.
- [3] Baker-Jarvis, J.; Vanzura, E.; Kissick, W. Improved Techniques for Determining Complex Permittivity with the Transmission/Reflection Method. IEEE Trans. Micro. Theory and Tech. 38: 1096-1103; 1990 August.
- [4] Baker-Jarvis, J.; Geyer, R.G.; Domich, P.D Improvements in Transmission Line Permittivity and Permeability Measurements. CPEM '90 Digest, IEEE Catalog No. 90CH2822-5, Conf. Prec. Elect. Meas. 232-233; 1990.

- [5] Vanzura, E.J.; Geyer, R.G.; Janezic, M.D. The NIST 60-millimeter Diameter Cylindrical Cavity Resonator: Performance Evaluation for Permittivity Measurements, to be published as Natl. Inst. Stand. Technol. Tech. Note 1354; 1993.
- [6] Vanzura, E.J.; Kissick, W.A. Advances in NIST Dielectric Measurement Capability Using a Mode-Filtered Cylindrical Cavity. Digest of the MTT-S International Microwave Symposium, 3: IEEE Cat. No. 89ch2725-0, 901-904; 1989.
- [7] Geyer, R.G.; Weil, C.M.; Kissick, W.A. Precision Dielectric Measurements Using a Mode-Filtered Cylindrical Cavity Resonator, Digest of the Conference on Precision Electromagnetic Measurements, IEEE Cat. No. 90ch2822-5, 174-175; 1990.
- [8] Ni, E.; and Stumper, U. Permittivity Measurements using a Frequency-Tuned Microwave TE_{01} cavity resonator. IEEE Proceedings, 132(H27-1): 27-32; 1985 February.
- [9] Vanzura, E.J.; Rogers, J.E. Resonant Circuit Model Evaluation Using Reflected S-parameters. IEEE Instrumentation and Measurement Tech. Conf. Proc., IEEE Cat. No. 91ch2940-5; 150-155; 1991 May.
- [10] Hartshorn, L.; Ward, W.H. The Measurement of the Permittivity and Power Factor of Dielectrics at Frequencies from 10^4 to 10^8 Cycles Per Second. Jour. I.E.E. 79: 597-609; 1936.
- [11] Broadhurst, M.G.; Bur, A.J. Two-Terminal Dielectric Measurements Up to 6×10^8 Hz. J. Res. Nat. Bur. Stand. (U.S.) -C. Engineering and Instrumentation, 69C(3): 165-172; 1965 July-September.
- [12] Rasmussen, A.L.; Hess, A.E. R-F Permeameter Techniques for Testing Ferrite Cores. Elec. Manuf. 61: 86; 1958 May.
- [13] Rasmussen, A.L.; Powell, R.C. A Low-Impedance Maxwell Bridge for Measuring Toroidal Magnetic Materials from 1 kc to 100 kc. Proc. I.R.E. 50(12): 2505; 1962 December.
- [14] Rasmussen, A.L.; Enfield, A.W.; Hess, A. Advances in the Design and Application of the Radio-frequency Permeameter. J. Res. Nat. Bur. Stand. (U.S.) 56(5): 261-268; 1956 May.
- [15] Hoer, C.A.; Rasmussen, A.L. Equations for the Radiofrequency Magnetic Permeameter. J. Res. Nat. Bur. Stand. (U.S.) Engineer. and Inst. 67C(1): 69-76; 1963 March.

- [16] Rasmussen, A.L.; Allred, C.M. An Admittance Meter Technique to Measure the Complex Permeability at VHF. *J. Res. Nat. Bur. Stand. Engineer. and Inst.* 72C(1): 81-89; 1968 January-March.
- [17] Goldfarb, R.B.; Bussey, H. Method for Measuring Complex Permeability at Radio Frequencies. *Rev. Sci. Instr.* 58: 624-627; 1987 April.
- [18] Powell, R.C.; Rasmussen, A.L. A Radio-Frequency Permittimeter. *I.R.E. Trans. on Instr.* I-9(2): 179-184; 1960 September.
- [19] Bussey, H.E. Dielectric Measurements in a Shielded Open Circuit Coaxial Line. *IEEE Trans. Instr. Meas.* IM-29: 120-124; 1980 June.
- [20] Baker-Jarvis, J.; Janezic, M.D.; Stafford, R.B. Shielded Open Sample Holders for Dielectric and Magnetic Measurements of Liquids and Powders. *Natl. Inst. Stand. and Technol. NISTIR 5001*; 1993 March. 25 p.
- [21] Baker-Jarvis, J.; Janezic, M.D.; Domich, P.D.; Geyer, R.G. Analysis of an Open-Ended Coaxial Probe with Lift-Off for Nondestructive Testing of Dielectric and Magnetic Properties. Submitted to *IEEE Trans. Instr. and Meas.*
- [22] Clark, A.V.; Schapps, S.; Baker-Jarvis, J.; Geyer, R.G.; Auld, B. Intelligent Processing of Materials. *Natl. Inst. Stand. and Technol. NISTIR 4693*; 1991 March. 61 p.
- [23] Bussey, H.E.; Gray, J.E.; Bamberger, E.C.; Rushton, E.; Russell, G.; Petley, W.; Morris, D. International Comparison of Dielectric Measurements. *IEEE Trans. Instr. and Meas.* IM-13(4): 305-311; 1964 December.
- [24] Bussey, H.E.; Morris, D.; Zal'tsman, D.B. International Comparison of Complex Permittivity Measurement at 9 GHz. *IEEE Trans. Instr. and Meas.* IM-23(3): 235-239; 1974 September.
- [25] Bussey, H.E.; Gray, J.E. Measurement and Standardization of Dielectric Samples. *I.R.E. Trans. Instr.* I-11(3-4): 162-165; 1962 December.
- [26] Geyer, R.G. Dielectric Characterization and Reference Materials. *Natl. Inst. Stand. and Technol. Tech. Note 1338*; 1990 April. 116 p.
- [27] Geyer, R.G.; R.F. and Microwaves Dielectric and Magnetic Characterization of Ferrites. Presented at the PIERS (Progress in Electromagnetic Research), Symposium held in Pasadena, CA.; 1993 July.
- [28] Baker-Jarvis, J. Transmission/Reflection and Short-Circuit Line Permittivity Measurements. *Natl. Inst. Stand. and Technol. Tech. Note 1341*; 1990 July. 148 p.

[29] Baker-Jarvis, J.; Janezic, M.D.; Grosvenor, J.H.; Geyer, R.G. Transmission/Reflection and Short-Circuit Line Methods for Measuring Permittivity and Permeability. Natl. Inst. Stand. and Technol. Tech. Note 1355; 1992 May. 112 p.

