



A11103 737622

NISTIR 4770

REFERENCE

NIST
PUBLICATIONS

Staging Areas for Persons with Mobility Limitations

John H. Klote
Harold E. Nelson
Scot Deal
Bernard M. Levin

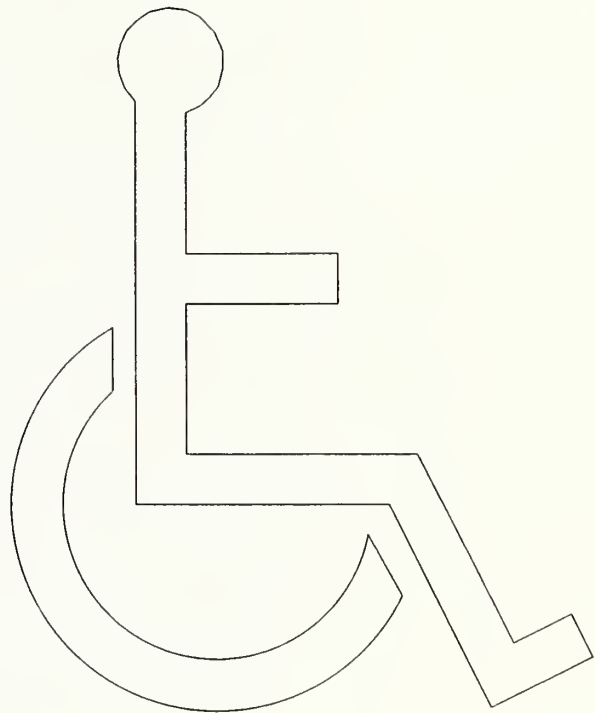

QC
100
U56
#4770
1997

Department of Commerce
Technology Administration
National Institute of Standards and Technology
Gaithersburg, MD 20899

Prepared for:
General Services Administration
Public Buildings Service
Office of Real Property Management and Safety
Washington, DC 20405

NISTIR
QC102
U.S.G.
4770
1990

Staging Areas for Persons with Mobility Limitations

John H. Klote
Harold E. Nelson
Scot Deal

Building and Fire Research Laboratory
Gaithersburg, Maryland 20899

Bernard M. Levin

George Mason University
Fairfax, VA 22030

February 1992

U.S. Department of Commerce
Rockwell A. Schnabel, *Acting Secretary*
Technology Administration
Robert M. White, *Under Secretary for Technology*
National Institute of Standards and Technology
John W. Lyons, *Director*

Prepared for:
General Services Administration
Richard G. Austin, *Administrator*
Public Buildings Service
Wolfgang Zoellner, *Acting Commissioner*
Office of Real Property Management and Safety
Washington, D.C. 20405

Table of Contents

	Page
List of Tables	v
List of Figures	vi
Executive Summary	1
1. Introduction	6
2. Field Tests of GSA Buildings with Staging Areas	7
2.1 Field Measurements and Inspections	7
2.1.1 Pressurization Tests	7
2.1.2 Door Gap Measurements	9
2.1.3 Visual Inspection	9
2.2 Veterans Administration Building	10
2.3 Whipple Federal Office Building	11
2.4 Toledo Federal Office Building	11
2.5 Bemidji Federal Office Building	12
2.6 Cohen Building	12
2.7 Pension Building	13
3. Tenability Criteria	13
4. Fire Threat Analysis	13
4.1 Fire History in Office Buildings	13
4.2 General	14
4.3 Exposure Fires	14
4.3.1 Single Module 1	15
4.3.2 Single Module 2	15
4.3.3 Module Group 1	15
4.3.4 Module Group 2	16
4.3.5 Single Module 2 with Standard Automatic Sprinklers	16
4.3.6 Single Module 1 with Quick Response Automatic Sprinklers	16
4.3.7 Smoldering Fire	17
4.3.8 Large Open Fires	17
4.4 Development of Potential Fire Threat	17
4.5 Approach Used	17
4.5.1 FIRE SIMULATOR	18
4.5.2 Corridor Flow Analysis	19
4.5.3 Time Available	19
4.5.4 Time Required	20
4.5.5 Safety within Staging Areas.	20
4.6 VA Building	21
4.7 Whipple Building	22

Table of Contents (continued)

	Page
4.8 Bemidji Federal Office Building	23
4.9 Toledo Federal Office Building	24
4.10 Cohen Building	25
4.11 Pension Building	26
4.12 Smoldering Fires	27
5. Human Response Considerations	27
5.1 Fire Emergency Plan and Training	28
5.2 Coordination with the Fire Department	29
5.3 Occupant Reactions to the Staging Areas	29
5.4 Building Features	29
5.4.1 Doors	29
5.4.2 Communications	31
5.4.3 Signs	31
5.5 Systems Approach	31
5.6 Staging Areas Add Complexity	31
6. Discussion	32
6.1 Ability to Evaluate Potential Safety of Staging Areas	32
6.2 Suitability of Fire Scenarios Used in Evaluation	32
6.3 Fire Safety Status of Staging Areas in the Six Buildings Evaluated	32
6.4 Design of Safety System Based on Staging Areas	34
6.5 Special Concern for Staging Area Without a Second Means of Escape	34
6.6 Potential of Upgrading Staging Areas by Increasing Pressurization	35
6.7 Impact of Automatic Sprinkler Protection	35
6.8 The Impact of Human Behavior and Emergency Management Factors	35
7. Conclusions	36
8. References	36
Appendix A Special Analysis of Office Building Fires	121
Appendix B Analysis of Mass Flows and Contaminant Concentrations in Staging Areas	145

List of Tables

	Page
Table 1.	Typical leakage areas of walls and floors of commercial buildings 39
Table 2.	Field test data of the staging areas at the VA Building 40
Table 3.	Dimensions of gaps around doors at the VA Building 41
Table 4.	Field test data of the staging areas at the Whipple Federal Office Building 41
Table 5.	Field test data of the staging areas at the Toledo Federal Office Building 42
Table 6.	Field test data of the staging areas at the Bemidji Federal Office Building 42
Table 7.	Field test data of the basement staging area at the Cohen Building 43
Table 8.	Dimensions of gaps around east doors at Cohen Building 43
Table 9.	Dimensions of gaps around west doors at Cohen Building 44
Table 10.	Field test data of the staging areas at the Pension Building 44
Table 11.	Tenability limits 45
Table 12.	Fires used as basis for analysis in this report 46
Table 13.	Conditions Exposing Staging Area 47
Table 14.	Estimated egress travel time in VA Building 48
Table 15.	Time factors in reaching staging areas in VA Building 49
Table 16.	Estimated egress travel time in Whipple Building 50
Table 17.	Time factors in reaching staging areas in Whipple Building 51
Table 18.	Estimated egress travel time in Bemidji Federal Office Building 52
Table 19.	Time factors in reaching staging areas in Bemidji Building 53
Table 20.	Time to untenable conditions in staging area in basement of Bemidji Building 54
Table 21.	Estimated egress travel time in Toledo Federal Office Building 55
Table 22.	Time factors in reaching staging areas on open plan floor in Toledo Building 56
Table 23.	Time factors in reaching staging areas on corridor plan floor in Toledo Building 57
Table 24.	Time to untenable conditions in staging area on second floor of Toledo Building 58
Table 25.	Estimated egress travel time in Cohen Building (East or West Wing) 59
Table 26.	Time factors in reaching staging areas on corridor plan floor in Cohen Building 60
Table 27.	Time to untenable conditions in staging area on second floor of Cohen Building 61
Table 28.	Time to untenable conditions in staging area in basement of Cohen Building 61
Table 29.	Estimated egress travel time in Pension Building 62
Table 30.	Time factors in reaching staging areas on corridor plan floor in Pension Building given a 25 MW fire in atrium 63
Table 31.	Impact of Smoldering Fires in Different Buildings 64
Table 32.	Minimum air supply needed to maintain smoke free conditions in the staging area 65

List of Figures

	Page
Figure 1.	Flow hood for measuring volumetric flow rate 66
Figure 2.	Set-up for measuring pressure difference across a door 67
Figure 3.	Feeler gage for measuring small gaps such as those around doors 67
Figure 4.	Gap between door and door frame 68
Figure 5.	Basement A plan of the VA Building 69
Figure 6.	Basement B plan of the VA Building 70
Figure 7.	Basement C plan of the VA Building 71
Figure 8.	Typical plan of floors 2 through 11 of the VA Building 72
Figure 9.	Basement plan of the Whipple Federal Office Building 73
Figure 10.	Typical plan of floors 2 through 6 of the Whipple Federal Office Building 74
Figure 11.	Typical plan of floors 2 through 7 of the Toledo Federal Office Building 75
Figure 12.	Basement plan of the Bemidji Federal Office Building 75
Figure 13.	Typical plan of floors 2, 3 and 4 of the Bemidji Federal Office Building 75
Figure 14.	Basement plan of the Cohen Building 76
Figure 15.	Typical plan of floors 2 through 5 of the Cohen Building 77
Figure 16.	Plan of floor 2 of the Pension Building 78
Figure 17.	Plan of floor 3 of the Pension Building 79
Figure 18.	Plan of floor 4 of the Pension Building 80
Figure 19.	Rate of heat release curves of fires for office buildings 81
Figure 20.	Rate of heat release curves from Module Group 2 fire 82
Figure 21.	Rate of heat release curves used in atrium of Pension Building 83
Figure 22.	Layout used in FREEBURN calculations 84
Figure 23.	Actual and adjusted fire curves used in FREEBURN calculations 85
Figure 24.	Sprinkler impact adjustment curve 86
Figure 25.	Types of emergency actions following alarm 87
Figure 26.	Smoke temperature in open plan space in VA Building 88
Figure 27.	Smoke level in open space in VA Building 89
Figure 28.	Gas concentrations in open plan space in VA Building 90
Figure 29.	Rate of heat release curve used in open plan spaces in VA Building 91
Figure 30.	Smoke temperature in individual room VA Building 92
Figure 31.	Smoke level in individual room in VA Building 93
Figure 32.	Gas in smoke in individual room in VA Building 94
Figure 33.	Heat release rate used in individual room calculations in VA Building 95
Figure 34.	Smoke temperature in an individual room in Whipple Building 96
Figure 35.	Smoke level in an individual room in Whipple Building 97
Figure 36.	Gas concentrations in smoke in individual room in Whipple Building 98
Figure 37.	Rate of heat release used in Whipple Building 99
Figure 38.	Smoke temperature in an individual room in Bemidji Building 100
Figure 39.	Smoke level in an individual room in Bemidji Building 101
Figure 40.	Gases from Module 2 fire in individual room in Bemidji Building 102
Figure 41.	Gases from Single Module 1 fire in individual room in Bemidji Building 103
Figure 42.	Smoke flow from individual room in Bemidji Building into corridor 104
Figure 43.	Rate of heat release within individual room in Bemidji Building 105

List of Figures (continued)

	Page
Figure 44.	Mass flow rate from an individual room in Bemidji Building into corridor 106
Figure 45.	Temperature profiles in corridor of Bemidji Building 107
Figure 46.	Smoke temperature in open area in Toledo Building 108
Figure 47.	Smoke level in open plan space in Toledo Building 109
Figure 48.	Oxygen in smoke in open plan area in Toledo Building 110
Figure 49.	Carbon monoxide in smoke in open plan in Toledo Building 111
Figure 50.	Carbon dioxide in smoke in open plan area in Toledo Building 112
Figure 51.	Temperature profiles in corridor in the Toledo Building 113
Figure 52.	Temperature profile in corridor of Cohen Building 114
Figure 53.	Smoke temperature in atrium in Pension Building 115
Figure 54.	Smoke level in atrium in Pension Building 116
Figure 55.	Oxygen in smoke in atrium of Pension Building 117
Figure 56.	Carbon monoxide in smoke in atrium in Pension Building 118
Figure 57.	Carbon dioxide in smoke in atrium in Pension Building 119
Figure 58.	Vision distance in smoke in atrium in Pension Building 120

Staging Areas for Persons with Mobility Limitations

Executive Summary

The National Institute of Standards and Technology (NIST) has completed a project funded by the General Services Administration (GSA) to evaluate the concept of a staging area as a means of fire protection for persons with disabilities as it applies to Federal office buildings. There is a rising concern for the safety of persons from fire who can not travel the building emergency exit routes in the same manner or as quickly as expected of able persons. One proposed solution for providing safety for persons with such disabilities is the provision of staging areas where they can "safely wait" until they can be assisted in safely leaving the building. The concept of such areas (using a variety of names including areas of refuge, areas of rescue assistance, and staging areas) has been promoted by a number of advocacy groups interested in persons with disabilities. Several regulatory documents such as the Life Safety Code (NFPA 1991) and the recently published guidelines for the implementation of the Americans with Disabilities Act (Department of Justice, 1991) give descriptions of such areas. There is, however, no history of use and to the best of our knowledge no prior physical tests or scientifically based fire safety analysis of staging areas.

The GSA has modified six buildings for fire protection of persons with mobility disabilities. The two types of systems used were staging areas and horizontal separation. Horizontal separation consists of one or more barriers which divide a floor into separate areas with the intent of restricting smoke and fire. These barriers include automatic closing doors.

The staging areas are intended as spaces in which people with disabilities can safely wait during a fire. The spaces that were turned into staging areas include passenger elevator lobbies, service elevator lobbies, sections of corridor, and rooms. Not all of the staging areas have direct access to stairwells or elevators. When the staging areas do not open directly onto stairs or elevators, these areas are located near a stairwell or elevator. All staging areas in the six GSA buildings were pressurized with outside air. Many of the staging areas had power operated, folding doors that had a level of fire endurance. There is currently only one manufacturer of these automatic folding doors.

Because these six GSA buildings were the first buildings ever to be retrofitted as discussed above, there were no precedents upon which to base the design or operation of the systems. Before this study the considerable extent of the complexity of these systems and the interaction between the systems and people were unknown. It is not surprising that significant operational problems were uncovered with these first systems. These unavoidable problems coupled with the diversity of the applications in the six buildings resulted in a unique opportunity to learn about these systems.

Field Tests: Field tests of the six GSA buildings were conducted which determined the leakage areas between the staging areas and other building spaces. These areas were obtained by pressurization tests using the staging areas own pressurization smoke control systems. Also the leakage areas of gaps around doors in barriers of horizontal separations were measured.

Threat Analysis: An essential step in evaluating the capability of the staging areas and related systems to fulfill the fire safety needs of persons with disabilities is the evaluation of the potential fire threat that may be faced. The procedures used include: the models and other evaluation features contained in the fire hazard analysis programs of FPETool (Nelson 1990); the procedures outlined by Steckler (1989) for estimating the conditions developed by smoke flow through corridors; the smoke flow model ASCOS (Klote and Fothergill 1983); and the N-GAS Toxicity Model (Bukowski et al. 1989). Also used were results from recent research and tests conducted at NIST. The general objective in selecting these fires was to have for each location a fire that would (if not suppressed) produce flashover in the given room or space being analyzed, a fire that in the same space would approach but would not reach flashover, and a smoldering fire. Details of mass flow and concentration calculations are presented in Appendix B.

Analysis of estimated movement time to staging areas were made for the following classes of evacuation capability:

1. **Able Person:** Assumed to travel on level surfaces at a speed of 76 m (250 ft) per min and on standard stairs at a vertical descent rate of 12 m (40 ft) per min.
2. **Fast Disabled Person:** Assumed to travel on level surfaces at a speed of 76 m (250 ft) per min. It is also assumed that such individuals can not descend stairs or surmount curbs or similar barriers.
3. **Slow Disabled Person:** Assumed to travel on level surfaces at a speed of 27 m (90 ft) per min and to additionally require a 2 minute rest at the end of each 30 m (100 ft) of travel. It is also assumed that such individuals can not descend stairs or surmount curbs or similar barriers. These values are those recommended by the proposed regulations for the implementation of the Americans with Disabilities Act (Department of Justice 1991).

Human Considerations: As with the physical design of staging areas, there is no background on the actions needed to assure that staging areas will be appropriately used at time of emergency. There is clearly a significant organizational, training, and coordination problem involved. Therefore, NIST contracted with George Mason University (GMU) to study the human considerations of staging areas. The GMU study (Levin and Groner 1992) addressed the following:

1. The willingness of persons with mobility limitations to accept and use staging areas or horizontal separations.
2. The approach taken by the present Building Emergency Organization and the type of assistance that is needed in buildings with staging areas.
3. The level of coordination needed with fire departments or others who will be expected to rescue persons from staging areas.
4. The type of information and training needed for persons who will use the staging areas, persons who should not use these areas, and those responsible for emergency functions.

The GMU team visited the six GSA buildings with staging areas, observed the staging area systems in operation during fire drills, studied the fire emergency plans, interviewed building officials, and interviewed building occupants. In general the GMU team found that the introduction of staging areas

greatly complicates tasks needed to assure that both the able and disabled occupants would act to their mutual best interest at time of fire. Their report makes a number of suggestions that they believe will help. There is however an obvious need for more study. The sum evaluation of their study is that it is possible with proper guidance and sufficient diligent effort to develop an emergency management program that has a good chance of success. Conversely there is a good possibility that the staging area concept will fail if not continuously supported with organization, education and training. They also point out that at present the guidance needed by those responsible for emergency operations does not exist.

The use of staging areas adds complexity to the design and maintenance of the building's fire safety features and to the emergency response procedures. The GMU team recommended that additional staging areas should be constructed (and current ones should continue to be used) only if procedures and systems are introduced to assure that they are properly designed, constructed and maintained and only if proper attention is given to the informational needs of the building occupants, including the monitors. It is not clear that this can be consistently achieved.

Discussion of Staging Areas:

1. **VA Building:** The Veterans Administration (VA) Building in Washington DC has eleven stories above ground and three basements. Two staging areas are located on each basement level. The protection approach used on floors 2 through 11 is horizontal separation. When the current renovations are concluded this building will provide a degree of safety for *all persons*, regardless of their abilities, above that presently provided for able persons in new code conforming buildings. This is the result of the fire controlling ability of the quick response automatic sprinkler system being installed at this time. It should be expected that anyone who is not intimate with the initial fire will not be harmed if a fire starts in this building.
2. **Whipple Building:** The Whipple Federal Office Building in Ft. Snelling Minnesota has a basement, ground floor, and floors numbered 1 through 6. The ground floor and the first floor have exits directly to the outside. On floors 2 through 6, the service elevator lobby was converted into a staging area. When the planned installation of total sprinkler protection (using standard heads) is completed this building will also provide a degree of safety for *all persons* at least equal to that presently provided for able persons in new code conforming buildings and above that provided in buildings built under a prior version of typical codes. Again the sprinkler protection is the prime reason for this high level of safety. In terms of safety for occupants of staging areas there is no difference between the protection delivered by the system using standard sprinkler heads to be installed in this building and the sprinkler system using quick response heads being installed in the VA Building. There is a difference in the room of fire origin. With the standard heads the calculations show the room of origin becoming momentarily harmful just before the first sprinkler head activates. This momentary untenable condition does not occur in the calculations based on quick response heads. It should be expected, however, that anyone who is not intimate with the initial fire and is able to leave any room involved with fire will not be harmed if a fire starts in this building.
3. **Bemidji Federal Office Building:** The Bemidji Federal Office Building is located in Bemidji, Minnesota, and it has four stories above ground and a basement. Staging areas were made of a section of corridor in the basement and on floors 2, 3 and 4. These staging areas open onto both a stairwell and an elevator. So long as the smoke control system pressurizing the staging area

operates when called upon, the staging area can be expected to indefinitely provide a life supporting atmosphere except in the case of extreme wind conditions at the same time as a flashed over fire. In this latter case or if the smoke control system fails to operate, the staging areas could reach lethal conditions in 1 to 4 minutes depending on wind speed. The calculations reveal, however, that the time available for individuals to reach the staging area is very short. In the case of a slow disabled person located in the office furthest from the staging area, it is possible that person could not safely reach the staging area even if that person started to move at the instant of discovery. Any time used for any other purpose, even calling the fire department, seeking instructions, or waiting for assistance will increase the potential of being caught by lethal conditions while traversing the corridor.

The analyses for the Bemidji Building were based on design conditions of fire, wind, temperature, travel speed, travel distances, and time of fire discovery. In reality, few fires happen when all of these design conditions occur simultaneously. For conditions less severe than these design conditions, better staging area system performance is expected.

4. **Toledo Federal Office Building:** The Toledo Federal Office Building has seven stories and a basement. The first floor and basement have an exit directly to the outside, so staging areas were provided on floors 2 through 7. On these floors, the passenger elevator lobby was converted into a staging area. This building is unsprinklered. Some floors of the Toledo Building have open floor plans and others have corridor arrangements. In the open office plan of Toledo Building the time available for non evacuation activities is slightly longer than that in the Bemidji Building. Further the times available for non evacuation activities in the corridor arrangement of the Toledo Building are as short as those in the Bemidji Building. Also the capability of the Toledo staging areas to maintain life supporting conditions is less than in the Bemidji Building. In the Toledo Building the calculations indicate some leakage of fire products into the staging area in all conditions. In no case did the period preceding lethal conditions exceed 15 minutes and with either a modest 4 m/s (9 mph) wind or failure of the smoke pressurization system, the onslaught of lethal conditions was very quick.

As with the Bemidji Building, the analyses for the Toledo Building were based on design conditions. For conditions less severe than these design conditions, better staging area system performance is expected.

5. **Cohen Building:** The Cohen Building is located in Washington DC, and the primary tenant is the Voice of America. This building has five stories above ground and a basement. There is a staging area in the basement, and floors 2 through 5 rely on horizontal separation for protection of persons with mobility disabilities. The building is not sprinklered. There is no smoke control system involved with the horizontal separation. The separate spaces developed are, however, very large and evacuees passing from the area involved in the fire to one of the other sections would have an extended period of tenable conditions. If the passage were from one of the wings to the main portion of the building, it is possible that the period of tenability would be indefinite. Periods exceeding 25 minutes would occur if the passage were from the main portion to a wing. A person attempting to evacuate one of the wings in face of a serious fire would, however, have a very short period of time available. In the case of a slow moving person some fires could produce lethal conditions before that person reached the safety of the separation cutoff. The staging area in the basement is an individual room. This room can be kept smoke free indefinitely so long as a pressurizing flow of at least 22 L/s (46 cfm) is provided. The room is, however,

subject to eventual failure if the pressurization system fails. As discussed, below, the basement staging areas do not have a second means of egress and can not be evacuated unless or until the corridor outside the staging area is tenable.

6. **Pension Building:** The Pension Building is a four story building located in Washington DC. Most of this building is used for the National Building Museum. A four story atrium is surrounded by show spaces on the first floor and offices on upper floors. Staging areas are located on floors 2, 3 and 4. Fires in the office portion of this building will be controlled by the quick response sprinkler system in this building. The height of the roof of the atrium portion makes sprinkler protection in this area impractical and it is not so protected. Even so fires of less than approximately 25 MW will not develop lethal condition. Even if a fire should reach 25 MW, the occupants would have approximately 25 minutes to either evacuate the building or take refuge in the spaces provided.

Conclusions: The following conclusions apply specifically to the installations investigated in six GSA buildings. Since these buildings represent a wide range of sizes, shapes, geographical locations and approaches to safety, it is believed that methods of analysis used in this paper are applicable to many other buildings. However, individual buildings will require individual engineering analysis.

1. Staging areas can be either a haven or a hazard. The difference is highly dependent on details of design, the type of fire exposure, outside wind and temperature conditions, and the capability and reliability of the smoke control pressurization system. Without pressurization all staging areas are subject to lethal failure.
2. In many cases the persons most needing the staging area protection may be unable to reach that area before their pathways (corridor or aisle ways) become lethal.
3. The organizational and human behavior problems involved in the use of staging areas are significantly more complex than those associated with the traditional total exit approach. There are no model programs or other guidance on how to use staging areas and on what to expect when they are used. There is a distinct need for more research in this area.
4. The operation of a properly designed sprinkler system eliminates the life threat to all occupants regardless of their individual abilities and can provide superior protection for people with disabilities as compared to staging areas.

Staging Areas for Persons with Mobility Limitations

1. Introduction

The National Institute of Standards and Technology (NIST) is engaged in a project funded by the General Services Administration (GSA) to evaluate the concept of a staging area as a means of fire protection for persons with disabilities as it applies to Federal office buildings. Until recent decades persons with disabilities often found barriers that hindered their efforts to work in or otherwise do business in all types of structures including Federal office buildings. Progressively, improvements in barrier free access to Federal buildings and other physical improvements have increased the ability of persons with disabilities to use the Federal buildings. Ever increasing use of Federal buildings by such persons is expected. There is a rising concern for the safety of persons from fire who can not travel the building emergency exit routes in the same manner or as quickly as expected of able persons. One proposed solution for providing safety for persons with such disabilities is the provision of staging areas where they can "safely wait" until they can be assisted in safely leaving the building. The concept of such areas (using a variety of names including areas of refuge, areas of rescue assistance, and staging areas) has been promoted by a number of advocacy groups interested in persons with disabilities. Several regulatory documents such as the Life Safety Code (NFPA 1991) and the recently published guidelines for the implementation of the Americans with Disabilities Act (Department of Justice, 1991) give descriptions of such areas. There is, however, no history of use and to the best of our knowledge no prior physical tests or scientifically based fire safety analysis of staging areas.

The GSA has modified six buildings for fire protection of persons with mobility disabilities. The two types of systems used were staging areas and horizontal separation. Horizontal separation consists of one or more barriers which divide a floor into separate areas with the intent of restricting smoke and fire. These barriers include automatic closing doors.

The staging areas are intended as spaces in which people with disabilities can safely wait during a fire. The spaces that were turned into staging areas include passenger elevator lobbies, service elevator lobbies, sections of corridor, and rooms. Not all of the staging areas have direct access to stairwells or elevators. When the staging areas do not open directly onto stairs or elevators, these areas are located near a stairwell or elevator. All staging areas in the six GSA buildings were pressurized with outside air. Many of the staging areas had power operated, folding doors that had a level of fire endurance. There is currently only one manufacturer of these automatic folding doors.

Because these six GSA buildings were the first buildings ever to be retrofitted as discussed above, there were no precedents upon which to base the design or operation of the systems. Before this study the considerable extent of the complexity of these systems and the interaction between the systems and people were unknown. It is not surprising that significant operational problems were uncovered with these first systems. These unavoidable problems coupled with the diversity of the applications in the six buildings resulted in a unique opportunity to learn about these systems.

This paper addresses many aspects of staging areas and horizontal separation including performance of these protective systems, human behavior considerations, and the relative effectiveness of other approaches to fire protection of persons with physical disabilities.

2. Field Tests of GSA Buildings with Staging Areas

Field tests were conducted of the staging areas and other protective approaches in the six GSA buildings. The data from these tests is used in the analysis of this paper. The following sections describe these field tests and the protective approaches in these six buildings. The data of interest are the supply rate of pressurization air to staging areas, the resulting pressure difference, the estimated leakage area of the staging areas, and the leakage areas of door gaps in barriers of horizontal separations. This data is listed in tables 2 through 10. It should be noted that the systems addressed in the following sections were recently constructed, and in some cases these new systems did not function as expected. These instances are discussed below, but it is believed that these situations have been or will be corrected.

2.1 Field Measurements and Inspections

The methods of field measurement and inspection are discussed below to provide a background for the analysis that follow and to help others make similar field tests if additional staging areas are built.

2.1.1 Pressurization Tests

Pressurization tests were conducted to determine the leakage areas from staging areas. These tests also provided the flow rate of pressurization air into these spaces. The idea of these tests is to measure the flow rate of pressurization air into a space and the resulting pressure difference to estimate the leakage area. The leakage area from a pressurized space can be expressed as

$$A = \frac{m}{CK_o\sqrt{2\rho\Delta p}} \quad (1)$$

where:

A = leakage area, m² (ft²)

m = mass flow rate, kg/s (lb/s)

C = flow coefficient, dimensionless

ρ = density of air in leakage paths, kg/m³ (lb/ft³)

Δp = pressure difference across paths, Pa (in H₂O)

K_o = coefficient, 1.00 (12.9)

For small gaps around doors and construction cracks, the flow coefficient is usually in the range of 0.6 to 0.7. For the calculations of this paper, the value of 0.65 was used for the flow coefficient. Measurement of flow rates, pressure differences and air density are discussed later. The leakage area from the staging area to other locations on the same floor is of particular interest in later smoke transport and tenability analyses. This leakage area is referred to in this paper as being from the staging area to the building.

Strictly speaking equation (1) only applies to flow through one path. However, this equation can be used to estimate the leakage area of a number of paths, provided that all the paths have the same pressure difference across them and the mass flow rate is the total mass flow going through all the paths. The construction cracks from a room are numerous and of irregular shape. It is not practical to identify all of these paths and to measure the mass flow rate through them. For the pressurization tests discussed in this paper, the mass flow rate is indirectly determined. For example, consider a pressurized staging area connected to both the rest of the floor and to an elevator. Under normal pressurization conditions, the pressurization air flows from the staging area to the building and the rest flows into the elevator shaft. Under test conditions, the paths to the elevator shaft are sealed so that the mass flow of pressurization air into the staging area is approximately equal to the flow from it to the building. The flow rate into the staging area and the pressure difference between the staging area and the building are measured. Then equation (1) can be used to estimate the leakage of the staging area to the building.

The above approach is based on the principle of conservation of mass for steady flow, which states that the mass flowing into a space equals that flowing out of the space. For more complicated systems of flow paths from a staging area, all paths to spaces other than those on the same floor of the building are sealed. These other paths include stairwells, elevator shafts, mail chutes, and outside of the building. Once the other paths are sealed, the mass flow rate of pressurization air is approximately that flowing through the paths to the rest of the floor.

The flow rate from an air supply diffuser can be measured using a commercially available flow hood. Figure 1 illustrates such a hood measuring the flow rate from a ceiling diffuser. These flow hoods measure volumetric flow rate which is converted to mass flow rate by the relation

$$m = \frac{Q\rho}{K_m} \quad (2)$$

where:

Q = volumetric flow rate, m³/s (cfm)

K_m = 1.00 (60)

Some of the staging areas had air vents through which air flowed from the staging area. The flow hood was also used to measure this vented air. For a staging area with such venting, the mass flow rate in equation (1) is the supply air less the vented air.

The density of air can be calculated from the ideal gas equation

$$\rho = \frac{p}{RT} \quad (3)$$

where:

p = atmospheric pressure, Pa (in H₂O)

R = gas constant of air, 287.0 J/kg K (10.27 in H₂O ft³ lb⁻¹ °R⁻¹)

T = temperature of air, K (°R)

Standard atmospheric pressure is 101,325 Pa (407.255 in H₂O). The temperature of the supply air is measured at the diffuser, and the temperature of air leaving the space is considered to be at that of the space. For the field tests of this paper, temperature was measured by a commercially available battery-powered thermistor¹.

The set-up used for measuring pressure difference is illustrated in figure 2. A magnetically coupled differential pressure gage was used to measure the pressure difference. This gage has a zero adjustment that is used to correct for minor deviations in floor level. The convention of this set-up is that the instrument is on the high pressure side of the door. Experience has shown that adherence to a particular convention reduces confusion and thus the potential for human error. A hose connected to the low pressure port of the instrument goes through a gap underneath and is terminated with a tee on the low pressure side of the door. The tee is used to minimize any pressure errors due to air velocity. Alternatively, the tube can end without a tee provided that it is located so that the dynamic pressure component is negligible.

A flexible hose of 6.4 mm (0.25 in) outside diameter works well for many cases. A narrow gap may result in a pinched hose invalidating any measurement, and the hose is difficult to insert through the seals around the automatic folding doors. In these cases, the hose was connected to metal tubing which could be inserted under the door.

2.1.2 Door Gap Measurements

Frequently, hinged doors have gaps around them that are large enough to be measured either by a ruler or by a feeler gage (figure 3). The gap between a door and a door frame has a bend which results in two gap widths as illustrated in figure 4. The smaller of these widths is reported and used in the following analyses.

2.1.3 Visual Inspection

Visual inspection was used to evaluate the quality of tightness of separation barriers. Walls, floors and ceilings were examined for any obvious opening (such as holes above suspended ceilings). Small cracks in a large wall can result in significant leakage. These cracks occur at numerous locations including where walls meet other walls, floors, ceilings, door frames, window frames, electrical fixtures, lighting fixtures and ventilation grills. The geometry of these leakage paths is complicated, and only the outside can be

¹Mercury in glass thermometers would also be adequate for such temperature measurement.

seen during a visual inspection. It is believed that the leakage of barriers is more dependant on the quality of construction than on the construction materials.

Typical leakage areas of exterior walls, stairwell walls, elevator walls, and floors are listed in table 1. This table does not have specific data for separating partitions. Of the construction elements listed in table 1, separating partitions are most similar to stairwell walls. For this paper, a barrier of conventional construction without any obvious large openings is considered to have characteristics similar to average leakage as indicated in table 1 for stairwell walls. It is noted that the leakage data of table 1 includes leakage where walls meet door frames. However, table 1 leakage does not include gaps between doors and door frames and gaps (undercuts) between doors and the floor.

2.2 Veterans Administration Building

The Department of Veterans Affairs is located in the Veterans Administration (VA) Building in Washington DC. The building has eleven stories above ground and three basements. Listed in ascending order of elevation, the basements are named A, B and C. Two staging areas are located on each basement level as illustrated in figures 5 to 7, and these staging areas have automatic folding doors. The protection approach used on floors 2 through 11 is horizontal separation, with a pair of hinged doors on each floor.

This building was unsprinklered at the time of these field tests. However, the building is undergoing extensive renovation, and it will be sprinklered with quick response sprinklers and have an open office plan. (Note that the new open office plan is not shown in figures 5 to 8.) Unless otherwise stated the analysis and discussions of the VA Building are for the building as it will be after renovation.

Two pressurization systems supplied outside air to the basement staging areas: one for the three North areas and another for the three South areas. These staging areas have leakage areas, flow rates of pressurization air and pressure differences as listed in table 2. Flow of pressurization air into these rooms ranged from 9 to 230 L/s (20 to 480 cfm), and the resulting pressure differences ranged from 0 to 35 Pa (0 to 0.14 in H₂O). This range of pressure differences is very large, and it is believed that routine adjusting and balancing of the pressurization systems will result in more uniform pressurization. However, these data collected are sufficient for rough estimation of flow areas and for the other analyses that follow.

Most of the pressure differences above are considerably less than those suggested in NFPA 92A (1988) for smoke control. The NFPA suggestions are based on the approach of preventing smoke infiltration to protected spaces. For unsprinklered spaces, the NFPA recommendations are pressure levels equal to the buoyancy pressure of a fire plus a safety factor. The buoyancy pressure increases with floor-to-ceiling height and fire gas temperature as related by the equation in the appendix of NFPA 92A. The NFPA document suggests a minimum pressure difference of 24.9 Pa (0.10 in H₂O) for a ceiling height of 2.7 m (9 ft) and an exposure of 927°C (1700°F) near the smoke barrier. For a sprinklered space, NFPA suggests 12.4 Pa (0.05 in H₂O) for any ceiling height. By comparing these suggested values with those of table 2, it is apparent that most staging areas do not have the suggested levels of pressurization even for sprinklered spaces. Later in this paper, an alternative approach for analyzing tenability in staging areas is presented and applied to the six GSA buildings.

The floors above the first floor (figure 8) used horizontal separation as the protection approach for persons with mobility disabilities. From table 3, the total leakage around the doors ranged from 0.065 to 0.087 m² (0.70 to 0.93 ft²). This range is about 28% of the average leakage. By visual inspection, the leakage area of the separating partition was estimated as average tightness.

2.3 Whipple Federal Office Building

The Whipple Federal Office Building is located in Fort Snelling near Minneapolis, Minnesota. This building has a basement, ground floor, and floors numbered 1 through 6. The ground floor and the first floor have exits directly to the outside. The basement has a staging area (figure 9). On floors 2 through 6, the service elevator lobby was converted into a staging area (figure 10). All of the staging areas at the Whipple Building have automatic folding doors.

At the time of these field tests, the Whipple Building was unsprinklered, but standard sprinklers are being installed. Unless otherwise stated the analysis and discussions of the Whipple Building are for the building as it will be after sprinkler installation.

The flow rate of pressurization air into the staging areas ranged from 150 to 180 L/s (310 to 390 cfm) as listed in table 4. This relatively small floor-to-floor variation is indicative of a well balanced system. The pressure differences ranged from 3.7 to 8.2 Pa (0.015 to 0.033 in H₂O). The 3.7 Pa (0.015 in H₂O) was measured at floor 6, and it is an outlier. The average pressure difference was 6.6 Pa (0.027 in H₂O). The low pressure difference at floor 6 could not be due to excessive leakage between the staging area and the building, because this leakage was smaller at this floor than at all the others. It is believed that the low pressure difference at floor 6 was due to a relatively large leakage between the staging area and the service elevator shaft at this floor. As with the VA Building, the levels of pressurization are not sufficient to meet the NFPA suggestions for smoke control, but later analyses will treat tenability in these staging areas.

2.4 Toledo Federal Office Building

The Toledo Federal Office Building has seven stories and a basement. The first floor and basement have an exit directly to the outside, so protection for persons with physical disabilities was provided on floors 2 through 7. On these floors, the passenger elevator lobby was converted into a staging area as illustrated in figure 11. These staging areas had automatic folding doors on all floors, except the seventh which had hinged doors, because the seventh floor was undergoing renovation. This building is unsprinklered.

The flow rates of pressurization air varied from 260 to 450 L/s (560 to 960 cfm) as shown in table 5. A trend of lower flow rates at lower floors is observed. Considering that the outside temperature was only 12°C (54°F), it does not seem that stack effect was the dominant driving force behind this trend. It seems more likely that this trend is due to a combination of an unbalanced supply air system and non-uniform building leakage paths. The pressure differences for these staging areas range from 2.2 to 6.0 Pa (0.009 to 0.024 in H₂O). Again this is not sufficient to meet the NFPA suggestions for smoke control, but later analyses will treat tenability in these staging areas.

2.5 Bemidji Federal Office Building

The Bemidji Federal Office Building is located in Bemidji, Minnesota, and it has four stories above ground and a basement. Staging areas with automatic folding doors were made of a section of corridor in the basement and on floor 2, 3 and 4 (figures 12 and 13). These staging areas open onto both a stairwell and an elevator. They also open onto office spaces. The doors of these office spaces were replaced with fire rated doors with automatic closers to protect against fires in these offices.

These staging areas have pressurization supply outlets and vent air inlets. From table 6, the flow rates of pressurization air into these staging areas varies from 470 to 850 L/s (1000 to 1800 cfm), and the vented air from the staging areas varies from 30 to 150 L/s (60 to 320 cfm). The pressure differences range from 7 to 18 Pa (0.028 to 0.073 in H₂O).

It is believed that the vent air capability was incorporated to prevent excessive pressure differences. Considering that the pressure differences produced were insufficient to meet the NFPA suggestions, excessive pressure differences are not a concern. Pressure differences could be increased slightly by closing over the vent air inlets. However, later analyses will treat tenability in these staging areas.

2.6 Cohen Building

The Cohen Building is located in Washington DC, and the primary tenant is the Voice of America. This building has five stories above ground and a basement. There is a staging area in the basement, and floors 2 through 5 rely on horizontal separation for protection of persons with mobility disabilities. The basement staging area had a hinged door, and the horizontal separation had a pair of hinged doors at each floor. The building is not sprinklered.

As with the staging areas in Bemidji, the staging area in the basement of the Cohen Building has a pressurization supply outlet and vent air inlet. The flow rate of vent air was greater than that of pressurization air (table 7). The resulting pressure difference is listed as negative in table 7 to indicate that the staging area is at a lower pressure than its surroundings. Apparently, the field tests were conducted before adjusting and balancing of the air system. It is believed that after balancing, this system will produce pressure differences on the order of the others tested.

The leakage areas of gaps around the doors used for horizontal separation ranged from 0.030 to 0.041 m² (0.32 to 0.44 ft²) for both the East and West doors (tables 8 and 9). The average leakage area is 0.036 m² (0.39 ft²) per set of double doors at the Cohen Building. This compares to an average gap area per door of 0.078 m² (0.84 ft²) at the VA Building. It is interesting that the average gap area per set of double doors at the Cohen Building is less than half that at the VA Building.

Visual inspection of the separating partition at the Cohen Building revealed numerous openings through which smoke could flow unrestricted. It is believed that efforts are underway to correct this, and the analyses in this paper are based on the corrected condition.

2.7 Pension Building

The Pension Building is a four story building located in Washington DC. Most of this building is used for the National Building Museum. A four story atrium is surrounded by show spaces on the first floor and offices on upper floors. All of the spaces other than the atrium are sprinklered. Staging areas with automatic folding doors are located on floors 2, 3 and 4 as illustrated by figures 16, 17 and 18.

The staging areas have both pressurization supply outlets and vent air inlets. The flow rate of pressurization air ranged from 150 to 200 L/s (320 to 430 cfm), and that of vent air ranged from 0 to 9 L/s (0 to 20 cfm). The pressure differences ranged from 3 to 13 Pa (0.013 to 0.051 in H₂O).

In addition to the staging areas, there is a smoke control system which exhausts smoke from the top of the atrium. Most of the pressure differences listed in table 10 are less than those suggested by NFPA, but a tenability analysis presented later addresses this and the performance of the atrium smoke control system.

3. Tenability Criteria

The tenability limits used in the following analyses are listed in table 11. The effect of toxic gases is evaluated for concentrations of carbon monoxide (CO), carbon dioxide (CO₂) and Oxygen (O₂) using the N-Gas Toxicity Model which calculates the Fractional Exposure Dose (FED) presented by Bukowski et al. (1989).

4. Fire Threat Analysis

4.1 Fire History in Office Buildings

In order to place the problem in perspective, a report on the history of fatal fires in recent years was obtained from the National Fire Protection Association (NFPA). The report prepared by Dr. John Hall of the NFPA is included as Appendix A of this report. In summary the report emphasizes that fire fatalities in office buildings have been a rare event. On a national basis these office building fatalities have averaged less than 7 per year over the last 10 years. Most often they have occurred when the building was lightly occupied and usually involved either a very rapidly developing fire or a delay in providing the alarm to the eventual victims.

This report and recent investigations by NIST staff, however, demonstrate the potential of serious fire does exist. A prime example of such serious, though infrequent, fires is the fire in the First Interstate Bank Building (Nelson 1986) where fire developed in a manner similar to that described in this report as Module Group 2 (defined in section 4.3.4 of this report.) The fire in the First Interstate Bank Building rapidly involved an entire open plan floor of a large building. As with the majority of other fatal fires this was an after hours fire and the single fatality occurred when a building staff member took an elevator to the fire floor to investigate the cause of a smoke alarm. In another incident, the fire in the Peachtree-25th Street Building in Atlanta Georgia (Nelson and Turgel 1989) a sudden electric fault caused a flashed

over fire² in the corridor preventing egress except by a few who moved immediately, at a run. Since none of the reported incidents are known to have involved persons with reduced mobility, it not possible to use the NFPA data to predict with confidence the impact of a serious fire on their well being. The calculations in this report attempt to fill this gap.

4.2 General

An essential step in evaluating the capability of the staging areas and related systems to fulfill the fire safety needs of persons with disabilities is the evaluation of the potential fire threat that may be faced. The procedures used include: the models and other evaluation features contained in the fire hazard analysis programs of FPETOOOL (Nelson 1990); the procedures outlined by Steckler (1989) for estimating the conditions developed by smoke flow through corridors; the smoke flow model ASCOS (Klote and Fothergill 1983); and the N-GAS Toxicity Model (Bukowski et al. 1989). Also used were results from recent research and tests conducted at NIST. The purpose of this section is to detail the procedures and results of that threat evaluation. In scope this section covers for each building involved the initial fire development, the exposure to occupants while attempting to move to exits or staging areas, the time required for able and disabled persons to travel from a remote location to an exit or staging area, the potential fire exposure to the staging area, and the length of time that the staging area can be expected to remain tenable. Since, as previously noted, work is underway to provide total automatic sprinkler protection in both the VA and Whipple Buildings, The evaluation was made as the situation will be when the sprinklers are placed in service.

4.3 Exposure Fires

The operation of the fire growth model FIRE SIMULATOR, included in the FPETOOOL package and used in this analysis, requires that the user input the description of how the expected collection of fuels (fuel package) would burn in an open area with a very high ceiling. This is referred to as the free burn characteristic of the fire. The model FIRE SIMULATOR subsequently determines both the impact of the described fire on the conditions in the fire space and important impacts of the space on the free burn fire. In order to properly appraise the potential in the six buildings involved, it was necessary to derive ten different free burn fires spanning the range of fuels and conditions in these buildings. The fires used are

²Flashover is a phenomena that occurs in most major building fires. In the initial (pre-flashover) stages, fire development is controlled entirely by the availability of combustibile materials, the ease of fire spread and subsequent burning rate of the involved fuel. As the fire develops, however, the hot smoke and fire gases accumulate at the ceiling, heating all of the yet un-ignited materials in the room. The hot ceiling gases also radiate energy onto the burning fuel causing it to burn faster. This increased burning rate often results in a throttling of the available air supply, causing some of the fuel gases released by the combustibile material to collect, unburned, in the smoke layer. The smoke normally blackens at this time. When this combination of events reaches a temperature of about 550 to 600°C (1000 to 1100°F) the radiant heat from the hot gas layer will quickly ignite all of the exposed combustibile material. Frequently any combustibile gases accumulated in the smoke will find air and burn out at this time. When this rapid ignition of combustibile material or gases occurs, the fire often violently erupts from the room of origin spouting flame, hot fuel laden gases, and toxic smoke into adjacent spaces. This transition is called flashover, and a fire that has undergone this transition is called a flashed over fire.

based on the test work done at NIST and elsewhere. The general objective in selecting fires was to have for each location a fire that would (if not suppressed) produce flashover in the given room or space being analyzed, a fire that in the same space would approach but would not reach flashover, and a smoldering fire. The specific fires derived are listed in table 12 and plotted in figures 19, 20, and 21. A more detailed description of the fires and the sources of the data for them is as follows:

4.3.1 Single Module 1

Single Module 1 reproduces the rate of heat release results of a free burn test of a single work station conducted at NIST (Madrzykowski and Vettori 1992). The work station was an L-shaped work station assembled from traditional wood furniture and movable partitions. A 1.5 x 0.6 x 0.7 m high (60 x 24 x 30 in high) wooden desk with a metal frame and a 0.9 x 0.45 x 0.6 m high (36 x 18 x 24 in high) side extension. There was an acrylonitrile-butadiene-styrene (ABS) bucket chair with foam padding. A computer terminal with keyboard was placed on the desk. There were two 1.5 m (60 in) long by 1.6 m (65 in) high cloth covered fiberglass on metal frame partitions. There was a total of 97 kg (215 lb) of paper material in common office array including four xerox type boxes placed under the side extension of the desk. The total weight of the fuel package was 290 kg (640 lb). Ignition was by a gas burner simulating a waste basket fire. The resulting fire curve is shown in figure 19 as single module 1. This test produced a peak rate of heat release of 1.8 MW at 360 s (6 min) after ignition.

4.3.2 Single Module 2

This module was also tested at NIST (Madrzykowski and Vettori 1992). The work station was a U-shaped systems type of furniture. Work surfaces were particle board with high pressure laminant surfaces. The work surface was 1.8 x 0.6 x 0.8 m high (72 x 24 x 30 in high) supported by a metal frame. There was also a 0.3 m (12 in) wide shelf 1.8 m (72 in) long supported by partitions located about 0.45 m (18 in) above the work surface. An ABS bucket chair with foam padding was included. The enclosing partitions were each 1.6 m (66 in) high. 97 kg (215 lb) of paper material in common office array including four xerox type boxes with computer printouts under the work surface was present. Total weight of the fuel was 290 kg (640 lb). This test produced a peak rate of heat release of 7 MW at 480 s (8 min) as shown in figure 19.

4.3.3 Module Group 1

This fuel package consists of five Single Module 1 work stations. The hypothesized arrangement for these modules is shown in figure 22. The FPETOOL routine, FREEBURN, was used to predict the burning that would take place if ignition occurred involving the work station at position A in figure 22. FREEBURN was instructed to cause ignition of work station B based on a separation of 0.9 m (36 in.) and a critical incident flux of 20 kW/m² on work station B³. In order to simulate a relatively progressive advance of the fire, FREEBURN was also instructed to ignite work station C, D, and E at 300, 900, and

³ The value of 20 kW/m² is used as the basis of estimating the moment of ignition of a material that is normally resistant to ignition as described in the FPETOOL routine RADIANT IGNITION OF A NEAR FUEL.

1200 s after ignition of the first work station (A). Time, instead of incident flux was used to simulate the apparent fire propagation impact of the separating partitions. This produced the step type increase in rate of burning as shown for Module Group 1 in figure 19. All of the fire curves representing work stations ignited subsequent to the initial work station were adjusted to simulate the preheating of the exposed work station by the existing fire. The adjustment is shown in figure 23. This adjustment was performed by eliminating the slow development startup stage of the initial fire.

4.3.4 Module Group 2

This fuel package consists of five single module 2 work stations (described in 4.3.2, above) using system furniture elements. The program FREEBURN was again used to simulate the collective burning and items other than the initial item were also adjusted in their burning rate as shown in figure 23. The fire was assumed to start in work station B as shown in figure 23 with an aisle width of 0.9 m (36 in). In this case, however, FREEBURN was instructed to simulate ignition of each work station when exposed to a critical energy in excess of 20 kW/m². It is felt that moving the point of ignition to the more centrally located workstation B would more directly expose the other workstations and direct radiant flux would be the dominant form of fire spread. The resulting curve is shown in figure 19.

4.3.5 Single Module 2 with Standard Automatic Sprinklers

The expected rate of heat release from the burning of an item such as Single Module 2 in a room with a 2.7 m (9 ft) ceiling protected with standard automatic sprinklers was derived using the FIRE SIMULATOR model in FPETOOL. This model can also predict the time of activation of the sprinkler. The equation proposed by Madrzykowski (1992)⁴ for estimating the reduction in rate of heat production occurring in a sprinkler protected location was then used to adjust the rate of heat release following sprinkler activation. The curve recommended by Madrzykowski as well as the curve used and the relationship of those to the results of several tests are shown in figure 24. The resulting fire curves are shown in figure 20. The fire description produced by this method is conservative in light of the possibility of the sprinkler head being reasonably remote from the fire (2.1 m (7 ft)) and the fire itself being extensively shielded making suppression difficult. The approach used also assumes that water application occurs immediately on sprinkler application. The resulting fire description peaks at 400 kW at the moment of sprinkler activation, 330 sec. (5.5 min).

4.3.6 Single Module 1 with Quick Response Automatic Sprinklers

This fire description is similar to that discussed in 4.3.5, above, except that quick response sprinklers were used in the appraisal by FIRE SIMULATOR. This resulted in response of the sprinkler at a lower energy level and a subsequent faster reduction in the expected rate of heat release. The same items of conservatism and shielding of the fire are included. The plot of this curve is shown in figure 20. The resulting fire peaks at 265 kW at the moment of sprinkler application, 145 s (2.4 min).

⁴The equation used is $r = \exp(-0.0023t)$ where t is time in seconds after initiation of water spray, and r is the ratio of heat release at time t to the heat release at the time of initiation of water spray.

4.3.7 Smoldering Fire

The smoldering fire used in this analysis is that described in scenario 1, "Smoking Cigarette in a Sofa" in Hazard I, Fire Hazard Assessment Method, Volume I (Bukowski et al. 1989). The source of that cigarette ignition and subsequent smoldering fire data is Babrauskas and Krasny (1985). The smoldering fire simulated here is one that progresses linearly (a ramp function) from zero rate of heat release at the moment of ignition to 75 kW in 2700 sec (45 minutes).

4.3.8 Large Open Fires

The final three fire descriptions (items 8, 9, and 10 in table 12) were developed to simulate a fire in the atrium section of the Pension Building. The largest of these is a fire that reaches 25 MW represents an extreme fire such as the full involvement of a display or stage approximately 40m² (400 ft.²) in size. The other two represent proportionately less severe situations. The fire growth rate is an approximation based on type of fire growth expected in wooden pallets as reported by Heskestad in Section 6/Chapter 8 of the Fire Protection Handbook (NFPA 1991). The curves are plotted in figure 21.

4.4 Development of Potential Fire Threat

The threat to an individual consists of the fire caused changes in the environment during that individual's exposure to such conditions. For an able individual, it consists of the exposure while exiting the building. The level of threat changes both with time and the passage from areas of high hazard to those of lesser hazard such as from the exposed floor into the stairwell and finally out of the building. Disabled persons, who find themselves unable to leave the floor experience similar exposure as they either travel to a staging area, await rescue in a staging area, or attempt to ride out the fire at another location on the floor.

4.5 Approach Used

For each case an evaluation was made of the conditions facing the occupants during an evacuation from their work area to a staging area, to an enclosed stairwell or to the outside as appropriate for the capabilities of the individual and the particular design of the building. In each case involving the problems faced by disabled persons, it was assumed that at least one disabled person would start emergency movement from a location as remote as possible from the staging area. Calculations involving the egress of able persons assumed an occupancy density of approximately 14 m² (150 ft²) per person, with the population evenly distributed in the office portions of the building. The analysis estimated the fire exposure potentially imposed upon the staging area and the flow, if any, of heated toxic smoke and gases into the staging area. This flow analysis was based on expected winter temperature in the community and various wind conditions ranging from still air to 18 m/s² (40 mph). This information was in turn used to derive the expected conditions within the staging area and to evaluate how long an individual could safely remain, without rescue, in a staging area.

4.5.1 FIRE SIMULATOR

The model, FIRE SIMULATOR, was used in this analysis to:

1. evaluate the development of fire conditions inside the room or other space of fire origin, and
2. evaluate the thermal conditions (rise in temperature and depth of temperature layer) in any staging area where the analysis indicated leakage of hot gases from the fire side to the refuge side.

FIRE SIMULATOR is a single room, fire growth model included as part of the FPETOOL package (Nelson, 1990). It is designed to evaluate a change in conditions produced by a prescribed fire in an enclosed space. Investigations by Nelson and Deal (1991) demonstrate a good correlation between the output of this model and the development of conditions in test rooms.

Critical in the model is the impact of entrained air in the developing fire plume. FIRE SIMULATOR assumes a fire having a circular perimeter free to entrain air from all sides. To the extent that the initiating fire approximates such entrainment, the FIRE SIMULATOR model is reasonable. The rectangular arrangement of the office furniture modules that are the base of this analysis, is felt to be such a reasonable approximation.

FIRE SIMULATOR also assumes a single fire plume. This probably results in an initial over-prediction of the rise in temperature and under-prediction of the descent of the smoke layer in fires involving Module Group 1 or 2. As each module becomes ignited by exposure from another module, it is initially an individual fire. As the fire grows in intensity, however, it is expected that the plumes will coalesce into a single plume.

FIRE SIMULATOR also assumes a single temperature of the gases in the upper portion of the room. This is reasonable and rational for individual offices or similar spaces. In large open spaces such as those in the open plan portions of the Toledo Building, it must be expected that the areas remote from the point of fire initiation will be at a lower temperature than those near the point of fire.

For the severe case of the fire initiated by Module Group 2 fire, the conditions are similar to those reported by Nelson (1989) in the analysis of the First Interstate Bank Building fire. The open areas are of very similar size and the exposure judged to have occurred in that fire is very similar to that estimated for Module Group 2. In that fire, there was approximately 15 minutes between the initial flashover conditions⁵ in the area of fire origin and general involvement of the entire open plan portion of the floor of fire origin. Lethal conditions, however, caused the death of a member of the building staff who entered the floor of fire involvement from a freight elevator located almost diagonally opposite from the point of origin in an estimated range of 1 to 3 minutes from the time of the initial flashover. For the above reasons, it is felt that the FIRE SIMULATOR estimates of development in such large areas are reasonable.

⁵ While it is normally expected that flashover will instantly involve an entire compartment space, photographs and videos of the progression of fire in this building indicated a succession of flashover like occurrences as the fire progressed through the very large office space involved. Such a phenomenon may be possible in other very large spaces such as those in the open floor plan portions of the Toledo building.

FIRE SIMULATOR was also used to estimate the development of hazardous conditions in the atrium portion of the Pension Building. When using such a model in large areas, a major concern is the potential of the presence of a heated layer near the ceiling which will stratify smoke at an intermediate level. In the Pension Building, however, there are twenty four fans set to turn on at the moment of the sounding of any alarm. These fans have a limited capability but can move the air at an approximate rate of 0.5 air changes per hour. While this is not enough to have a significant impact on smoke removal, it will assist in removing any stratification layer that may have accumulated above the third floor level.

Finally, for the flaming fires, FIRE SIMULATOR predicts the carbon monoxide production on the basis of the recommendations of Mulholland as included as an appendix in the FPETOOL documentation. A special toxic gas evaluation is also made in the case of smoldering fires. FIRE SIMULATOR produces estimates of both carbon monoxide and carbon dioxide. For the smoldering fires, it was estimated that ten percent of the total of these two gases was carbon monoxide and ninety percent carbon dioxide.

For the open planned areas in the VA and Toledo Buildings, actual dimensions of that space were used. For those buildings where the evaluation is based upon a room opening on a corridor, an arbitrary choice of a room of 42 m² (450 ft²) was used.

4.5.2 Corridor Flow Analysis

The analysis of flow in corridors is based on the suggestions of Steckler's (1989) analysis covering principally the work of Heskestad and Hill (1987) and Hinkley (1970). The approach of Steckler reasonably reproduces the types of conditions observed in experiments (Nelson 1989, Heskestad and Hill 1987, and Madrzykowski 1991).

At present, however, the results should be considered more qualitative than quantitative. In this report, they are, however, expressed in a quantitative manner to determine a likely position and depth of the smoke front leaving a fire room. The results should be judged as general rather than the exact predictions of the times and limits calculated by the program. Work is underway by several researchers to improve the understanding of the corridor flow and to improve modeling of corridor flow. However, the current state-of-the-art was as used in this analysis. No attempt was made to use the results of the corridor flow routine in analyzing conditions in the main portion of the Cohen Building. The length, width, and complexity of that corridor system were beyond any current analysis approach.

4.5.3 Time Available

In estimating the time available for evacuation of the rooms and spaces immediately exposed to the fire, it was assumed that no action would take place and no alarm given until the fire reached either 200 kW (flame height approximately 1.5 m (5 ft)) or activation of a sprinkler head whichever occurred first. The termination of time available was considered to occur when an untenable condition existed. In most cases, this was the descent of a hot gas layer below the 1.5 m (5 ft) level.

4.5.4 Time Required

The amount of time required for evacuation includes the time from fire initiation to discovery, the time from discovery to alarm, the time from alarm to start of evacuation, and the actual movement time. Where flashover in a closed space is a potential, an additional estimate based on discovery at the time of flashover is made. The analysis uses the routine EGRESS from FIREFORM to estimate the movement time needed. EGRESS does not estimate the time from alarm to start of evacuation. Rather an estimate is made of the time margin available.

The time margin gives an indication of the maximum time that can be safely used in investigation of the situation, consultations, and decisions. It is important to realize that an apparently generous time margin can be used in activities that are not involved in movement towards a point of safety. Figure 25 abstracted from the SFPE Handbook chapter Emergency Movement (Nelson and McLennan, 1988) shows many of the types of activities that frequently occur at time of fire. If the indicated margin is exceeded there is the potential of the evacuees being exposed to lethal conditions.

In calculating the estimated movement time three classes of evacuation capability were used as follows:

1. **Able Person:** Assumed to travel on level surfaces at a speed of 1.27 m/s (250 ft/min) and on standard stairs at a vertical descent rate of 12 m (40 ft) per min.
2. **Fast Disabled Person:** Assumed to travel on level surfaces at a speed of 1.27 m/s (250 ft/min) It is also assumed that such individuals can not descend stairs or surmount curbs or similar barriers.
3. **Slow Disabled Person:** Assumed to travel on level surfaces at a speed of 0.47 m/s (90 ft/min) and to require a 2 minute rest at the end of each 30 m (100 ft) of travel. It is also assumed that such individuals can not descend stairs or surmount curbs or similar barriers. These values are those recommended by the proposed regulations for the implementation of the Americans with Disabilities Act (Department of Justice 1991).

4.5.5 Safety within Staging Areas.

The ability of the staging area to protect evacuees was evaluated on the basis of time to the development of untenable conditions, as defined in section 3, within the staging area. Both incapacitating and lethal conditions were determined in terms of the intrusion of fire products into the staging area that produced untenable temperatures, and concentrations of carbon monoxide (in combination with increased carbon dioxide and reduced oxygen levels.)

The general approach was to analyze the rate of flow into the staging area using the smoke model ASCOS (Klote and Fothergill 1983). The enthalpy of the intruding gases was derived from the temperature of the exposing fire products and the rate of flow calculated by ASCOS. FIRE SIMULATOR was then used to estimate the temperature and depth of the smoke layer (if any) in the staging area. The concentration of oxygen, carbon monoxide, and carbon dioxide were derived from the mass flow of gases into the staging area, flow of any gases from the staging area (as into elevator shafts, stairwells, etc.) and the relative concentration of the gases in these flows. The methods of calculation of mass flow and contaminant concentrations are described in further detail in Appendix B. The impact of the resulting conditions on

occupants was produced by the N-Gas model as published in the HAZARD I documentation. This model considers the interactive impact of these gases.

Both the VA Building and the Whipple Building were calculated on the basis of completion of the ongoing sprinkler protection projects. Since the calculated exposing conditions never reached untenable levels in these locations, there was no point in determining the flow rates into the staging areas.

In each case where the flows were calculated by ASCOS the input data was based on winter temperatures representing the 97.5% design temperature as given in the ASHRAE Handbook (1989). The temperatures used were:

City:	Winter Design Temperature	
	°C	°F
Bemidji, Mn	-32	-26
Toledo, OH	-17	1
Washington, DC	-8	17

For these analyses the flow areas between the staging areas and the building were those determined by the previously discussed field tests. The flow areas for the other parts of the building were based on engineering judgement using average tightness for Toledo and Washington and tight construction for Bemidji (see table 1 for leakage values for construction of various tightness).

A series of calculations were made covering both the expected high exposure temperature and a low exposure temperature, several wind conditions, and the presence or lack of operation of the smoke control system. Where the calculations indicated that there was at least one condition where the staging area could reach untenable conditions an additional calculation was made to determine how much of an increase in air flow would be needed to prevent any smoke intrusion.

4.6 VA Building

While the exact properties of the quick response heads that will be installed are unknown. It is assumed that these heads will have a response time index of $27.6 \text{ m}^{1/2}\text{s}^{1/2}$ ($50 \text{ ft}^{1/2}\text{s}^{1/2}$) and an activation temperature of 74°C (165°F). The preceding values are typical for quick response sprinkler heads. In the analysis the fire is positioned at a distance 2.13 m (7 ft) from the position directly under the sprinkler head. As part of the renovation, the previously installed horizontal separations are being relocated but will still be in the same general area dividing the building in two large but unequal segments. For this study, the smaller segment was evaluated. It was also estimated that about 20% of the floor area would be enclosed offices. It was estimated that the residual open plan space will have a floor area of approximately 1190 m^2 ($12,800 \text{ ft}^2$).

The FPETOOL runs using Group Module 2 as the source fire estimated activation of a quick response sprinkler at 146 seconds in the open plan space and at 112 seconds in a 42 m^2 (450 ft^2) office room with the door to the room standing open. At the time of activation in the open space the peak rate of heat release is estimated at 450 kW. In the small room, the peak is 225 kW. The conditions developed in the open space are graphed in figures 26 through 29. Conditions developed in a small room are shown in

figures 30 through 33. As shown in these graphs, the conditions in those parts of the building exposed to fire and in the staging area attained a maximum temperature of 30°C (85°F) after sprinkler operation, a minimum oxygen concentration of approximately 19%, a carbon monoxide concentration less than 100 ppm (above any ambient concentrations that may be present), and carbon dioxide concentrations less than 1%. It is probable that the action of the sprinkler heads will cause decreased vision, possibly obscuring light in the immediate vicinity of the fire. None of the conditions exceed human tenability limits. See table 13 for summary of the conditions in this and other buildings.

The time necessary for able and disabled persons to travel from a remote position in the area exposed to the fire environment to a stairwell for able persons or through the horizontal separation for disabled persons was estimated using the procedure EGRESS from FPETOOL. Table 14 lists the variables used and reports the results of that evaluation. This data were used to enter the time required in table 15 describing the margin of time available to the occupants should fire occur. The time margin in this case is unlimited because the action of the quick response sprinklers prevent harmful conditions from ever occurring.

Finally, appraisal was made of the capability of the horizontal separation in protecting those who pass through it. Since the conditions developed never reach a harmful level, safety is provided, even if the doors should never close.

4.7 Whipple Building

The sprinkler project for this building will use standard sprinkler heads. The analysis is based on sprinkler heads having a response time index of $165 \text{ m}^{1/2}\text{s}^{1/2}$ ($300 \text{ ft}^{1/2}\text{s}^{1/2}$) and an activation temperature of 74°C (165°F). These are typical values for standard sprinkler heads. The analysis assumes that the fire will be located approximately 7 ft from the nearest sprinkler head. Figures 34 through 37 outline the results of this analysis. The data shown are for the conditions in the room of fire origin opening onto a corridor. The FIRE SIMULATOR runs indicate that the temperature in the room rapidly rises to a temperature in excess of 65°C (150 °F) within about one minute of initiation and will briefly reach about 115°C (240°F) and descend below head height momentarily before the activation of the sprinkler systems. This is estimated to occur at about five minutes after ignition. Evacuation of the individual room will be necessary but should present no problem. Once the sprinkler operates the temperatures in the room will rapidly cool as indicated in figure 34. Conditions in the corridor, however, will never be untenable.

The EGRESS procedure estimation of egress time is based on an approximation of 320 persons per floor a few of which are disabled persons. The listing of the variables used and the results produced by EGRESS are presented in table 16. In the Whipple Building the calculated egress time for the able population is longer than that for a disabled person able to travel at the same speed. This is due to the expected queuing at the stairwell doors. This, of course, assumes that the staging area will be left available to the disabled person. Since conditions will remain tenable, the actual ability to get in the refuge area is one of comfort rather than safety importance.

Table 17 reports the evaluation of the time margin available for those attempting to reach an area of safety in the Whipple Building. In this case, the time margin is unlimited because untenable conditions are not expected. For the same reason, the conditions within the staging area will remain tenable.

4.8 Bemidji Federal Office Building

The Bemidji Building has a room on corridor arrangement with one end of the corridor enclosing an elevator and stairwell and used as a staging area. The remaining corridor is approximately 25 m (83 ft) in length and about 2.4 m (8 ft) wide. The fire situation used to simulate dangerous conditions in this building was a fire in a 42 m² (450 ft²) room. FIRE SIMULATOR evaluations using the various fires depicted in figure 19 demonstrated that all of the fires except Single Module 1 fire (1.8 MW peak rate of heat release) caused the space to flashover. The analysis, therefore, is based on the two conditions of a flashed over room and a sub-flashover condition involving a limited fire following the heat release potential of Single Module 1. The conditions generated in the burn room and the subsequent conditions in the adjacent corridor are independent of the floor examined. The resulting conditions in the staging area, however, are affected by stack effects which vary from floor to floor. In the Bemidji Building the basement floor was used for the evaluation. The estimated conditions produced in the room of fire origin are shown in figures 38 through 44.

Both cases were then evaluated using the corridor flow routine. This produced estimates that the smoke front would flow down the length of the corridor in less than 30 seconds after flashover and less than one minute after peaking of the Single Module 1 fire. The temperature distribution expected is shown in figure 45. The flashed over fire of course is the most significant, though both fires are capable of producing untenable temperature conditions in the evacuation corridor.

Table 18 presents the egress routine estimates of the time required to reach safety. Table 19 provides the data on the time available, and it is based on two conditions:

1. The first assumes that the fire is discovered and the alarm given when it is approximately 200 kW in size.
2. The second (appropriate to a fire in an unoccupied room or space) is based on discovery being concurrent with flashover.

In this case, there is a relatively short period of time between discovery and untenable hazard even if the fire is discovered at an early (200 kW) stage. If the fire is not discovered until flashover, the analysis indicates that able persons should be able to escape if they move immediately. The analysis, however, also indicates that slow disabled persons may not be able to safely reach the staging area. In any case, if any time is lost due to delay in giving the alarm, indecision or actions inappropriate to evacuation (such as investigation or fire fighting) it is likely that all of the time margin will be consumed.

The staging area in the basement was used as the test case in this building. If a person took refuge in this staging area and the smoke control (pressurization) system continued to operate as it did when tested, the space would remain safe unless:

1. the building were subjected to a high wind striking the side of the building where the fire existed, and
2. an exterior door was open.

In that case the staging area could fail, quickly becoming lethal in as short a time as 1 to 3 minutes following the window breakage.

Conversely, if the smoke control system did not operate, the staging area would become lethal, even in a still wind situation, in 1 to 4 minutes, depending on the temperature of the fire gases impinging on the door to the staging area. The results of the analysis of the staging area in the Bemidji Building are listed in table 20.

4.9 Toledo Federal Office Building

Some of the floors are open plan; others are room and corridor arrangement. Two separate analyses were made. One for an open floor plan and another for a room on corridor arrangement where the corridor connected to two stairwells but had no further extensions.

The open plan was based on a space 1580 m² (17,000 ft²). The only fire curve capable of flashing over that space is a fire based on Module Group 2. Conditions were therefore evaluated with each of the four fire curves to obtain an appraisal of the difference between them. The conditions produced in the open space always became untenable on the basis of temperature prior to any other condition. In the case of the conditions developed by the fire based on Module Groups 1 or 2 this occurred as the result of radiation from hot gases prior to their descent to head height. In the other two cases untenability first occurred as the result of a hot gas layer descending below head height. In the case of the fire generated by Single Module 1, lethal temperatures never occurred. In the cases based on Module Group 1 or Module Group 2 subsequent serious carbon monoxide, carbon dioxide, and oxygen depletion conditions did occur and are considered important in the exposure to the staging area. Figures 46 through 51 demonstrate the results of all of the cases calculated for the open plan space. FIRE SIMULATOR analyses predict the presence of lethal conditions in approximately 8 minutes for either Module Group 1 or Module Group 2 and in about 10 minutes for a fire developed by Single Module 2. In the case of Single Module 1, the descent required approximately 18 minutes to get below head height at which time the smoke was marginally tenable with a temperature of approximately 88°C (190°F). FPETOOL also estimated in that situation the smoke layer never descended below approximately 1.5 m (4 ft) above the floor.

Since the room on corridor scenario was estimated based on the same 42 m² (450 ft²) room as used in Bemidji, the conditions in the room are same as those for the Bemidji Building, figures 38 through 44. However, the corridor conditions are different because of the different corridor dimensions. The corridor temperature profile expected is shown in figure 51. The corridor flow calculation indicates that given flashover in an exposing room the wavefront would extend the full length of the corridor in less than 2 minutes. The initial wavefront would have a depth of approximately 0.7 m (2.3 ft). This would fill the corridor to head height in about 4 minutes and near the floor in about 8 minutes after flashover. The expected gas content in a flashover driven wave would be oxygen less than 1%, carbon monoxide approximately 3.5% and carbon dioxide approaching 10%. The temperature of the gas would vary according to the position in the corridor approximately as described in figure 51.

Conditions immediately outside the room of origin would be very severe and it is unlikely that anyone could pass that room even during the first few moments after flashover. Conditions under the smoke layer would be untenable due to radiation from the hot smoke as it flowed through the top portion of the

corridor. Also the fire gases would be highly toxic and once descended to head height would be lethal after a very short exposure.

In the open floor plan area, it is likely that the occupants will become aware of a fire by the time it reaches 200 kW. Because of the size of the space, conditions are expected to remain tenable for another 4 1/2 minutes.

This provides the occupants with between less than 1 minute to almost 4 minutes to initiate emergency evacuation depending upon their capability and the availability of the staging area (see table 21). On the floors with corridors, the time is even less if the fire is not discovered until the time of flashover (as might occur in an unoccupied space), the margin of time available drops drastically to where slow disabled persons may actually be entrapped even if they start evacuation immediately upon flashover occurrence. Tables 22 and 23 present estimated egress travel time calculations derived from the EGRESS procedure in FPETOOL and the time available calculations respectively.

Table 24 gives the expected time of safe occupancy of the staging areas in the Toledo Federal Office Building. The pressurization system for the staging areas in this building produce less net flow than those previously discussed in the Bemidji Building. In the Toledo Building the calculated time to lethal conditions for a staging area on the second floor varied from 13 to 22 minutes with the pressurization system operating and no wind. With a 4 m/s (9 mph) wind the time to lethal conditions with pressurization drops significantly (2 to 7 minutes). If the pressurization system were to not operate or if the wind approached 18 m/s (40 mph), the time to lethal condition again drops to about 1 minute following impact of the fire effects on the staging area doors.

4.10 Cohen Building

The Cohen Building has been analyzed as a room on corridor arrangement using the same individual fire room as previously described for the Bemidji Building. The current state-of-the-art is such that a mathematical analysis of the flow of smoke through the complex and extensive main corridor system is not feasible. It is possible that this system is large enough so that the side of the central section away from a fire may remain tenable. However, it would require scale modeling or tests in the building itself to make such a prediction with any degree of confidence.

It was possible, however, to make an estimate of the conditions should a fire occur in either the east or west wings. Even this stretches the capabilities of the corridor flow model used to estimate conditions in the corridor. Figure 52 shows the temperature profile estimated for a corridor exposed to either a flashed over room as would be produced by Module Group 2 or a sub-flashover fire that would occur from a Single Module 1. The analysis assumes that most, if not all, of the other doors to the corridor will be closed. If these doors are open, some leakage from the corridor will occur and conditions will be less severe. The corridor flow calculations expect that it would take about 7 minutes from the moment of flashover for the smoke front to proceed from one end of the corridor to the other a distance of approximately 98 m (320 ft). The progression would be rapid reaching the far end of the corridor in about 1.5 minutes and filling to head height in about 3 minutes. If the fire should occur between the occupants and the single connection to the main building, it would be essential that any evacuees pass that point prior to flashover. Table 25 shows the egress flow times required for both able and disabled

persons. Since the travel distance for all persons are the same, the estimated time for able and fast-disabled is the same (0.8 minutes) while that for slow-disabled persons is 2.2 minutes.

Table 26 shows the margin of time available for decision and other actions related to evacuation. Again, if discovery is not until time of flashover, the time margin is greatly reduced.

Tables 27 and 28 show the duration of safety in the Cohen Building. Table 27 depicts conditions on one of the upper floors if a fire exists in the main core portion of the building and either the east or west wing is serving as an area of refuge. Here the combination of the ability of the large building volume of the main section to absorb the impact of wind on a broken window and the relatively large volume of the wing produce a condition that can provide tenable conditions for an extended period of time. Actually the calculation assumed that all of the office doors in the wing would be closed and that the only volume available to the smoke would be the corridor. Table 28 covers the results from the calculations for the basement area. In this calculation it was assumed that the staging area had a net air supply of 190 L/s (400 cfm). At the time of the NIST visits to the building the air supply was defective and additional work is planned to correct the defects. When that work is done and the actual flow is measured a recalculation of the results in table 28 may be needed.

4.11 Pension Building

The analysis in this building has been based on a fire in the atrium. FIRE SIMULATOR was used to estimate the development of conditions in the atrium space. In this, it was assumed that the fans at the top of the atrium would be on at the time of the fire. These fans have the capability of moving air at approximately 0.5 air changes per hour. This low rate of air change has little effect on the descent of the smoke layer but can reduce any stratification that may occur, particularly on hot summer days. Even with stratification, however, the calculations indicate such extensive dilution of the fire effects by the entrainment in the rising fire plume that serious conditions would not be expected to occur until such time as the fans had removed the hot air and/or the fire itself had produced sufficient temperature to penetrate the stratification layer.

The FIRE SIMULATOR results are shown in figures 53 through 58. The evacuation time estimates from the egress routine are shown in table 29. The vast volume of the atrium portion of this building and the fact that it extends almost 24 m (80 ft) above the head height on the top floor results in massive entrainment reducing the temperature and diluting combustion products of any fire. Also, since the fire would be free burning in the atrium, FIRE SIMULATOR indicates very low production of carbon monoxide and the oxygen concentration is maintained about 18% for a period in excess of 45 minutes. For the fires less than 25 MW, the conditions developed never exceed tenable temperatures (based on a maximum tenable temperature during the egress to the refuge area of 82°C (180°F)). Actually, the temperature remains below 50°C (120°F) for almost twenty minutes. The analysis assumes that the exit doors from the building, particularly those at the east end, will be open at times of emergency. This will tend to limit the depth of the smoke to approximately 3 m (10 ft) above floor level. The smoke is expected to have descended to the top floor level in about ten minutes from initiation and to present (in the case of the 25 MW fire exposure) vision difficulties after about twenty minutes. At that time, it is calculated that the vision will have decreased to the point where an exit light can be seen for about 15 m (50 ft). It is possible, that with this lead time, the most likely approach to evacuation of persons with disabilities would be to assist them down the stairs rather than take refuge in the staging areas. However,

the estimated egress travel time for individuals with mobility disabilities is based on reaching the staging areas. The estimated evacuation travel time is shown in table 29.

Table 30 provides an estimate of the margin time available for decision making or other actions. In this building, it is estimated to be at least twenty minutes.

4.12 Smoldering Fires

FIRE SIMULATOR was used to evaluate the impact of smoldering fires on the evacuation routes or imposing upon the refuge areas. Table 31 lists the results of this analysis. The smoldering fire analysis was based on a fire smoldering for 45 minutes. It is expected that it would be discovered and extinguished long before that in an occupied building. The carbon monoxide levels indicated in table 31 are for the concentrations occurring at the end of the 45 minute exposure. The only place where these calculations indicate a concentration threatening to life is that which would occur in a closed 42 m² (450 ft²) room. In such case, conditions at or approaching lethality would occur at approximately 45 minutes.

5. Human Response Considerations

As with the physical design of staging areas, there is no background on the actions needed to assure that staging areas will be appropriately used at time of emergency. There is clearly a significant organizational, training, and coordination problem involved. Therefore, NIST contracted with George Mason University (GMU) to study the human considerations of staging areas. The GMU study (Levin and Groner 1992) addressed the following:

1. The willingness of persons with mobility limitations to accept and use staging areas or horizontal separations.
2. The approach taken by the present Building Emergency Organization and the type of assistance that is needed in buildings with staging areas.
3. The level of coordination needed with fire departments or others who will be expected to rescue persons from staging areas.
4. The type of information and training needed for persons who will use the staging areas, persons who should not use these areas, and those responsible for emergency functions.

In general the GMU team found that the introduction of staging areas greatly complicates tasks needed to assure that both the able and disabled occupants would act to their mutual best interest at time of fire. Their report makes a number of suggestions that they believe will help. There is however an obvious need for more study. The sum evaluation of their study is that it is possible with proper guidance and sufficient diligent effort to develop an emergency management program that has a good chance of success. Conversely there is a good possibility that the staging area concept will fail if not continuously supported with organization, education and training. They also point out that at present the guidance needed by those responsible for emergency operations does not exist. The following are some specific points raised by the GMU team.

The GMU team visited the six GSA buildings with staging areas, observed the staging area systems in operation during fire drills, studied the fire emergency plans, interviewed building officials, and interviewed building occupants. The following discussion addresses topics believed to be relevant to the evaluation of the advantages and limitations of the staging areas in the six GSA buildings, as well as, evaluation of the staging area concept itself. Information about other aspects of human considerations of staging areas is provided in the GMU study.

5.1 Fire Emergency Plan and Training

In each GSA building, a "Designated Official"⁶ is responsible for developing the occupant emergency plan, and selecting and training occupant emergency organization members. Levin and Groner found that the Designated Officials need more assistance to be able to perform these tasks adequately. Training aids would be helpful. Some viewgraphs and diagrams should apply, unchanged, in a good percentage of buildings with staging areas.

Existing Occupant Emergency Plans based on guidance from the GSA document "Occupant Emergency Program Guide" establish an organizational structure for emergency situations. However they were not designed to provide useful information to the typical building occupant. A document should be distributed to each employee that describes the fire emergency plan in simple language. Information regarding staging areas needs to be added to the Occupant Emergency Plan or a separate document regarding staging areas needs to be created.

Employees (called floor monitors, area monitors, etc.) who are assigned responsibilities in emergency situations need more assistance to perform their duties, e.g., formal training, group discussions, and feedback discussion sessions immediately after drills. Employees with disabilities need to be kept current as to who is assigned to assist them.

Employees with mobility impairments need to be instructed on the operation of the safety features of the staging areas and told how they provide safety. During their visits, the GMU investigators did not find any such training underway or planned.

Potential users of the staging areas must have confidence in the safety of the staging areas. To build confidence, employees need be given information on the staging areas features as, for example, the existence of a special ventilation system to supply the staging area with clean outside air. Care must be taken not to destroy confidence in the system by, for example, having staging area identification signs visible during the construction period and before the system is fully operational. Use of the staging areas during this period might be hazardous. Detailed guidance in developing and evaluating fire emergency plans and in implementing them is provided in Appendix A of the GMU report.

⁶The "Designated Official" is the highest ranking official of the primary occupant agency of a GSA building or is a selected by mutual agreement of occupant agency officials.

5.2 Coordination with the Fire Department

There is the implicit assumption that the fire department will rescue building occupants from the staging areas but there was little contact between the fire department and the people designing, installing and using the staging areas. What little contact that GMU found appeared to be with the fire prevention side of the fire department. This has a variety of consequences. The GMU investigators were unaware of any pre-fire planning conducted by local fire departments regarding how they would modify their response to a fire in response to the installation of the staging areas. In one building, there was a sign in the staging areas instructing the users to report their locations by dialing 911; the fire department was unaware of this and, prior to the GMU visit, had not instructed those answering "911" about the existence of the staging areas. In another building, GMU noted that efforts were made to involve the local fire department but the overtures were rebuffed.

Building management needs to inform the fire department of the existence and design of staging areas. The fire department should be alerted during the design stage to give it the opportunity to make suggestions for improving the design and assuring the design is consistent with their operating procedures. Staging areas should be included in the pre-fire plan and familiarization visits of the fire department.

5.3 Occupant Reactions to the Staging Areas

The following items are based on comments made by potential users of staging areas during GMU interviews:

1. Some of the staging areas are too small to be comfortable or prevent employees from feeling "trapped." It is not known if such feelings would discourage the use of staging areas.
2. Some small staging areas may serve other functions, in addition to being a lobby or passageway, if those functions are carefully selected and the staging area is properly designed.
3. Occupants with mobility impairments expressed the view that they would like to have a window to the outside in the staging area.
4. None of the staging areas had chairs or other furniture that would permit seating. A majority of the potential users of staging areas are assumed to be ambulatory and not users of wheelchairs or similar devices. Seating is needed for ambulatory occupants who have physical impairments that would make it difficult to stand for any period of time or to sit on the floor.

5.4 Building Features

5.4.1 Doors

The GMU team found the following problems with the automatic folding doors as installed in the staging areas in five of the six buildings:

1. They do not have a viewing panel to provide visibility outside the staging area which could decrease the anxiety of occupants awaiting rescue. Further, such a panel would allow occupants outside the staging area to view conditions inside before deciding to enter the staging area.
2. These automatic folding doors have a safety feature to stop the closing of the door when the door encounters an obstruction such as a slow moving person. The GMU investigators found that this feature was not operating properly on some of the doors, and these doors could close on slow moving people resulting in injury.
3. Each automatic folding door has an alarm which sounds when the doors are activated. The loudness of these alarms would cause severe communication difficulties during a fire emergency. These alarms should be properly deactivated (so as not to interrupt other associated safety features) or made much less intrusive.

Automatic folding doors are available with viewing panels, and the door manufacturer has indicated to GMU that corrections are underway or completed for items 2 and 3.

The automatic folding doors, as used in the GSA buildings studied, are fire doors with a 1 1/2 hour rating designation. In every application it would have been possible to have installed a more traditional fire door with the same rating, presumably at a lower cost. The automatic folding door does have advantages, as well as disadvantages, from a human factors standpoint.

A major advantage of the automatic folding door is that it moves perpendicular to the direction of travel of the users, i.e. it does not swing. This has several desirable consequences:

1. Users can be quite close to the door without any problems.
2. The panel for opening the door can be on the door. This makes it easier to find and permits the user to be ready to enter or leave the area as soon as the door opens. Hence the door is open for a shorter period of time.
3. The door, as with any power operated door, is easy to open by a person with little strength which is common among persons likely to be using staging areas.
4. The door can be fitted with an effective mechanism for stopping quickly whenever encountering an obstacle and still, under normal circumstances, close rather rapidly.

An important disadvantage of the powered automatic folding doors is that conventional doors can be open just slightly to check conditions, and can be closed quickly to limit smoke entry; automatic folding doors cannot.

In some applications, the automatic folding doors have aesthetic advantages in that they can be less obvious than conventional doors. However, because these doors are less obvious, they could result in reduced knowledge of and confidence in the staging areas. If further staging areas are built, it seems that architects and engineers should choose the type of door that is best for their specific application.

5.4.2 Communications

For buildings with horizontal separations, procedures need to be developed to provide occupants with disabilities with the information as to which part of the building they should go (one may contain the fire).

A phone or intercom system within the staging area, while not needed for the physical safety of those seeking refuge, would greatly add to their psychological comfort, and the information given the fire department by the occupants of staging areas could affect the priorities of actions by the fire department. The use of the phones or intercom is sufficiently complicated that informational signs and training of occupants, for the setup particular to their building, is needed.

If the communications systems are to function effectively, both the staging areas and the receiving office must be sufficiently quiet for the communicating persons to hear each other. In some cases, the noise from automatic door alarms and fire alarms located in the staging areas made the communication systems useless. In other cases, the central points of communications from the staging areas were in guard rooms where a very loud fire alarm sounds during the fire emergency, making the intercom useless. More noise can be tolerated if phones rather than intercoms are used.

5.4.3 Signs

Signs should be included as part of the staging area installation. If GSA provides the signs, the Designated Official should have the authority to add to or modify the signs, to customize them to specific buildings.

Signs should not be visible until the staging area is fully operational.

5.5 Systems Approach

The study of staging areas in six Federal buildings clearly demonstrated the importance of taking a systems view of staging areas throughout the design and implementation phases. The systems view needs to be based on a solid understanding of how staging areas will be used, that is, the life safety strategy that underlies the entire system. With such a systems view, numerous errors in hardware design might have been avoided. Similarly, emergency coordinators need to base their plans on the same life safety strategy. For example, a systems view could have helped emergency coordinators to identify and address problems such as failing to communicate with occupants inside staging areas or planning on how and when they might be rescued.

5.6 Staging Areas Add Complexity

The use of staging areas adds complexity to the design and maintenance of the building's fire safety features and to the emergency response procedures. The GMU team recommended that additional staging areas should be constructed (and current ones should continue to be used) only if procedures and systems are introduced to assure that they are properly designed, constructed and maintained and only if proper

attention is given to the informational needs of the building occupants, including the monitors. It is not clear that this can be consistently achieved.

6. Discussion

6.1 Ability to Evaluate Potential Safety of Staging Areas

This report demonstrates both the feasibility and the importance of analytical evaluation of the capability of a building fire safety system to safeguard occupants of all levels of ability. It is important that the analysis be complete from the moment of fire initiation until achievement of safety or the presence of untenable conditions. Partial analysis such as an abstract calculation of the ability of a staging area can lead to erroneous conclusions.

6.2 Suitability of Fire Scenarios Used in Evaluation

As noted in section 4 of this report the fire death rate in office buildings in the United States is low. National records indicate an average of seven per year over the last 10 years. The scenarios used in the analyses in this study, however, are based on the types of fires that have resulted in deaths remote from the point of fire origin and on recent fire tests conducted at NIST of modern office furniture. The NIST tests produced fires in the general range of severity covering the scope of serious office building fires. The results of these tests are discussed in section 4. The fire burning rates and intensities measured in these tests were used as the basis for all evaluations made in the five standard office buildings involved. Other sources as discussed in section 4 were used for the analysis of the atrium in the Pension Building. It is felt that the fire scenarios used are the proper design basis and within the range that must be expected in these buildings.

6.3 Fire Safety Status of Staging Areas in the Six Buildings Evaluated

The following evaluations are derived from the more detailed analysis included in section 4 of this report:

1. **VA Building:** When the current renovations are concluded this building will provide a degree of safety for *all persons*, regardless of their abilities, above that presently provided for able persons in code conforming buildings. This is the result of the fire controlling ability of the quick response automatic sprinkler system being installed at this time. It should be expected that anyone who is not intimate with the initial fire will not be harmed if a fire starts in this building.
2. **Whipple Building:** When the planned installation of total sprinkler protection (using standard heads) is completed this building will also provide a degree of safety for *all persons* at least equal to that presently provided for able persons in new code conforming buildings and above that provided in buildings built under a prior version of typical codes. Again the sprinkler protection is the prime reason for this high level of safety. In terms of safety for occupants of staging areas there is no difference between the protection delivered by the system using standard sprinkler heads to be installed in this building and the sprinkler system using quick response heads being

installed in the VA Building. There is a difference in the room of fire origin. With the standard heads the calculations show the room of origin becoming momentarily harmful just before the first sprinkler head activates. This momentary untenable condition does not occur in the calculations based on quick response heads. It should be expected, however, that anyone who is not intimate with the initial fire and is able to leave any room involved with fire will not be harmed if a fire starts in this building.

3. **Bemidji Federal Office Building:** So long as the smoke control system pressurizing the staging area operates when called upon, the staging area can be expected to indefinitely provide a life supporting atmosphere except in the case of extreme wind conditions at the same time as a flashed over fire. In this latter case or if the smoke control system fails to operate, the staging areas could reach lethal conditions in 1 to 4 minutes depending on wind speed. The calculations reveal, however, that the time available for individuals to reach the staging area is very short. In the case of a slow disabled person located in the office furthest from the staging area, it is possible that person could not safely reach the staging area even if that person started to move at the instance of discovery. Any time used for any other purpose, even calling the fire department, seeking instructions, or waiting for assistance will increase the potential of being caught by lethal conditions while traversing the corridor.

The analyses for the Bemidji Building were based on design conditions of fire, wind, temperature, travel speed, travel distances, and time of fire discovery. In reality, few fires happen when all of these design conditions occur simultaneously. For conditions less severe than these design conditions, better staging area system performance is expected.

4. **Toledo Federal Office Building:** In the open office plan of the Toledo Building the time available for non evacuation activities is slightly longer than that in the Bemidji Building. Further the times available for non evacuation activities in the corridor arrangement of the Toledo Building are as short as those in the Bemidji Building. Also the capability of the Toledo staging areas to maintain life supporting conditions is less than in the Bemidji Building. In the Toledo Building the calculations indicate some leakage of fire products into the staging area in all conditions. In no case did the period preceding lethal conditions exceed 15 minutes and with either a modest 4 m/s (9 mph) wind or failure of the smoke pressurization system, the onslaught of lethal conditions was very quick.

As with the Bemidji Building, the analyses for the Toledo Building were based on design conditions. For conditions less severe than these design conditions, better staging area system performance is expected.

5. **Cohen Building:** Horizontal protection is used on the upper floors of the Cohen Building by using fire/smoke cutoffs separating the east and west wings from the main building. There is no smoke control system involved. The separate spaces developed are, however, very large and evacuees passing from the area involved in the fire to one of the other sections would have an extended period of tenable conditions. If the passage were from one of the wings to the main portion of the building, it is possible that the period of tenability would be indefinite. Periods exceeding 25 minutes would occur if the passage were from the main portion to a wing. A person attempting to evacuate one of the wings in the face of a serious fire would, however, have a very short period of time available. In the case of a slow moving person some fires could produce lethal conditions before that person reached the safety of the separation cutoff. The staging area

in the basement is an individual room. This room can be kept smoke free indefinitely so long as a pressurizing flow of at least 22 L/s (46 cfm) is provided. The room is, however, subject to eventual failure if the pressurization system fails. As discussed, below, the basement staging areas do not have a second means of egress and can not be evacuated unless or until the corridor outside the staging area is tenable.

6. **Pension Building:** Fires in the office portion of this building will be controlled by the quick response sprinkler system in this building. The height of the roof of the atrium portion makes sprinkler protection in this area impractical and it is not so protected. Even so, fires of less than approximately 25 MW will not develop a lethal condition. Even if a fire should reach 25 MW, the occupants would have approximately 25 minutes to either evacuate the building or take refuge in the spaces provided.

6.4 Design of Safety System Based on Staging Areas

The design of a safety system based on the staging area concept is a complex engineering task involving:

1. a fire safety analysis covering the initial fire development, the discovery and alarming of the developing fire, the subsequent course of conditions in the routes involved in reaching the staging areas, the information communicated to the building occupants, the travel time that such occupants will be in the routes to the staging areas, and the impact such will have on their well being.
2. a total building smoke management analysis covering all aspects that affect any staging areas. The analysis needs to consider the effects of the fire conditions exposing the staging areas, stack effect, and wind effects. This phase of the analysis must appraise the impact of any intrusion of fire products (both thermal and non-thermal) into the staging areas and the resulting impact on the period that such staging areas will be tenable for occupants.
3. an emergency system analysis covering the education and training of building occupants, coordination with those who will be expected to rescue or otherwise assist persons in staging areas, communications during an emergency, the means of evacuating persons from staging areas, and both pre-fire and trans-fire design and maintenance features needed to assure that the systems will operate when called on.

This report along with the documents referenced in it present an initial method reflecting the current state-of-the-art for making the several analyses. It is felt that the approaches presented produce reasonable results in most buildings related to fire hazard and smoke management but only general concepts relative to emergency system analysis.

6.5 Special Concern for Staging Area Without a Second Means of Escape

Staging areas have been built in the Pension Building, the basement of the VA Building, and the Basement of the Cohen Building where the only means of leaving the staging area is the entrance door to that area. In each of these cases this door is exposed to the corridor or other space that is expected to

be the source of untenable conditions. In all cases it must be expected that the conditions in the exposing space will be more toxic than those in the staging area even if the staging area is approaching untenable conditions. As shown by this study staging areas can not be assumed to provide absolute safety. They are subject to degradation of conditions as a function of not only the intensity of fire exposure but also the wind, outside temperature, tightness of enclosure, and performance of the smoke control system. For these reasons it can not be assumed that a staging area can be safely occupied unless conditions in the exposing corridor allow escape or rescue.

6.6 Potential of Upgrading Staging Areas by Increasing Pressurization

An evaluation was made of the level of minimum net air flow rate needed to assure that several of the staging areas would remain smoke free under the most severe of the exposures evaluated. In each case this was the hottest exposure, with a 18 m/s (40 mph) wind, and a broken window on the windward side. The cases evaluated were the staging areas in the Bemidji Building basement, in the Cohen Building basement, and on the second floor of the Toledo Building. The results are shown in table 32. As shown in that table a three fold increase in the flow in the Bemidji Building and a 13 fold increase in the flow in the Toledo Building would be needed. While an exact engineering study would be needed to determine the other impacts of such an increase in flow rate, it is expected that a system of sensors, variable supply rate fans, feedback design, and an air flow management system (either pneumatic or electronic) would be needed. Such an elaboration would increase the maintenance needs and the number of potential means of system failure.

6.7 Impact of Automatic Sprinkler Protection

The analysis shows that sprinklers can provide superior protection for people with disabilities as compared to staging areas. The reliability of sprinklers is historically much higher than the reliability of the combination of systems involved in staging areas. As an agency practice GSA includes valve supervision, water flow, and central station supervision of both the valves and the water flow on every sprinkler system. These devices increase reliability. However, if sprinklers are to be used as an essential life safety feature every effort to achieve perfect reliability is needed. As sprinkler systems become more omnipresent, sprinkler reliability deserves further study and development.

6.8 The Impact of Human Behavior and Emergency Management Factors

In each of the six buildings studied, efforts are underway to adapt the Occupant Emergency Plans and adjust emergency organizations to help provide safety to occupants with evacuation related disabilities. To realize the full potential of this effort, it will be necessary to determine the best approaches to pursue. This needs to be done in light of the potential speed of development of lethal conditions pointed out for nonsprinklered buildings in this report. In such buildings it is apparent that the time available to individuals who are slow in movement, must travel long distances to staging areas or both can be very short, under some condition even nil. Unless these persons are located close to the staging area and move immediately upon fire discovery, there is a potential for them to encounter untenable conditions along their route to staging areas. In nonsprinklered buildings there is a need for a major, perpetual

commitment to organization, coordination, education, training, and the continual updating of the assignments of the monitors.

In the sprinklered buildings, the occupants are safeguarded from physical harm by moving away from the immediate area of fire involvement, and a high level of safety would be provided to occupants with mobility problems even if less attention were directed to the Occupant Emergency Plan. Nevertheless, there still is a need to communicate with employees with mobility problems so that they understand the value of the sprinkler protection to their individual well being and so that they go about their normal activities without fear.

7. Conclusions

The following conclusions apply specifically to the installations investigated in six GSA buildings. Since these buildings represent a wide range of sizes, shapes, geographical locations and approaches to safety, it is believed that methods of analysis used in this paper are applicable to many other buildings. However, individual buildings will require individual engineering analysis.

1. Staging areas can be either a haven or a hazard. The difference is highly dependent on details of design, the type of fire exposure, outside wind and temperature conditions, and the capability and reliability of the smoke control pressurization system. Without pressurization all staging areas are subject to lethal failure.
2. In many cases the persons most needing the staging area protection may be unable to reach that area before their pathways (corridor or aisle ways) become lethal.
3. The organizational and human behavior problems involved in the use of staging areas are significantly more complex than those associated with the traditional total exit approach. There are no model programs or other guidance on how to use staging areas and on what to expect when they are used. There is a distinct need for more research in this area.
4. The operation of a properly designed sprinkler system eliminates the life threat to all occupants regardless of their individual abilities and can provide superior protection for people with disabilities as compared to staging areas.

8. References

- Babrauskas, V; Krasny, J. F. 1985. Fire Behavior of Upholstered Furniture. Natl. Bur. Stand. Monograph 173.
- Bukowski, R.W., Peacock, R.D., Jones, W.W. and Forney, C.L. 1989. Software User's Guide for HAZARD I, NIST Handbook 146, Vol I and II, National Institute of Standards and Technology, Gaithersburg, MD.
- Department of Justice. 1991. Nondiscrimination on the Basis of Disability by Public Accommodations and in Commercial Facilities; Americans with Disabilities Act 28 CFR Part 36, Final Rule, Federal Register, July 26.
- Heskestad, G. and Hill, J.P. 1987. Propagation of Fire Smoke in a Corridor, Proceedings of the 1987 ASME-JSME Thermal Engineering Joint Conference, 1 March 22-27, 1987, Honolulu, HI, American Society of Mechanical Engineers, Martro, P.J. and Tanasawa, I., Editors, pp 371-379.
- Hinkley, P.L. 1970. The Flow of Hot Gases Along an Enclosed Shopping Mall, F.R. Note No 807, Fire Research Station, Borehamwood, Herts, UK.
- Klote, J.H. and Fothergill, J.W. 1983. Design of Smoke Control Systems for Buildings, American Society of Heating, Refrigerating and Air-conditioning Engineers, Atlanta, GA.
- Levin, B.M. and Groner, N.E. 1992. Effectiveness of Staging Areas in Office Buildings - Program to Appraise and Provide Guidance for Human Behavior and Emergency Management Aspects Using Staging Areas, National Institute of Standards and Technology, to be published.
- Madrzykowski, D. 1991. The Reduction in Fire Hazard in Corridors and Areas Adjoining Corridors Provided by Sprinklers, National Institute of Standards and Technology (U.S.), NISTIR 4631.
- Madrzykowski, D. and Vettori, R.L. 1992. A Sprinklered Fire Suppression Methodology for the GSA Engineering Fire Assessment System, NIST, to be published.
- Nelson, H.E. 1990. FPETOOL: Fire Protection Engineering Tools for Hazard Estimation, Nat. Inst. Stand. Tech. (U.S.), NISTIR 4380.
- Nelson, H.E. 1988. An Engineering Analysis of the Fire of May 4, 1988 in the First Interstate Bank Building, Nat. Inst. Stand. Tech. (U.S.), NISTIR 4061.
- Nelson, H.E. and Turgel, R. 1989. Preliminary Engineering Analysis of the Fire of June 30, 1989 Involving the Peachtree - 25th Building, 1720 Peachtree St., Atlanta, GA.
- Nelson, H. E. and Deal, S. 1991. Comparing Compartment Fires with Compartment Fire Models, Proceedings of the Third International Symposium on Fire Safety Science, Elsevier, New York pp 719-728.

NFPA 1988. Recommended Practice for Smoke Control Systems, NFPA 92A, Quincy, MA, National Fire Protection Assn.

Steckler, K.D. 1989. Fire Induced Flows in Corridors -- A Review of Efforts to Model Key Features, Nat. Inst. Stand. Tech. (U.S.), NISTIR 89-4050.

Tamura, G.T. and Wilson, A.G. 1966. Pressure Differences for a Nine-Story Building as a Result of Chimney Effect and Ventilation System Operation, ASHRAE Transactions, Vol 72, Part 1, pp 180-189.

Tamura, G.T. and Shaw, C.Y. 1976a. Studies on Exterior Wall Air Tightness and Air Infiltration of Tall Buildings, ASHRAE Transactions, Vol. 82, Part 1, pp. 122-134.

Tamura, G.T. and Shaw, C.Y. 1976b. Air Leakage Data for the Design of Elevator and Stair Shaft Pressurization Systems, ASHRAE Transactions, Vol. 82, Part 2, pp. 179-190.

Tamura, G.T. and Shaw, C.Y. 1978. Experimental Studies of Mechanical Venting for Smoke Control in Tall Office Buildings, ASHRAE Transactions, Vol. 86, Part 1, pp. 54-71.

Table 1. Typical leakage areas of walls and floors of commercial buildings

Construction Element	Tightness	Area Ratio ¹
Exterior Building Walls (includes construction cracks, cracks around windows and doors)	Tight ²	0.7×10^{-4}
	Average ²	0.21×10^{-3}
	Loose ²	0.42×10^{-3}
	Very Loose ¹	0.13×10^{-2}
Stairwell Wall (includes construction cracks but not cracks around windows or doors)	Tight ⁴	0.14×10^{-4}
	Average ⁴	0.11×10^{-3}
	Loose ⁴	0.35×10^{-3}
Elevator Shaft Walls (includes construction cracks but not cracks around doors)	Tight ⁴	0.18×10^{-3}
	Average ⁴	0.84×10^{-3}
	Loose ⁴	0.18×10^{-2}
Floors (includes construction cracks and gaps around penetrations)	Tight ⁵	0.66×10^{-5}
	Average ⁶	0.52×10^{-4}
	Loose ⁵	0.17×10^{-3}

¹For a wall the area ratio is the area of the leakage through the wall divided by the total wall area. For a floor the area ratio is the area of the leakage through the floor divided by the total area of the floor.

²Values based on measurements of Tamura and Shaw (1976a).

³Values based on measurements of Tamura and Wilson (1966).

⁴Values based on measurements of Tamura and Shaw (1976b).

⁵Values extrapolated from average floor tightness based on range of tightness of other construction elements.

⁶Values based on measurements of Tamura and Shaw (1978).

Table 2. Field test data of the staging areas at the VA Building

Room	Pressure Difference*		Pressurization Air**		Estimated Leakage Area Between Staging Area and Building	
	Pa	in H ₂ O	L/s	cfm	m ²	ft ²
C South	35	0.14	230	480	0.046	0.50
C North***	5.0	0.020	19	40	0.01	0.1
B South	27	0.11	430	920	0.10	1.1
B North***	7.0	0.028	24	50	0.01	0.1
A South****	0.0	0.00	9	20	NA	NA
A North***	2.5	0.010	57	120	0.05	0.5

*Pressure differences are from staging area to the building with pressurization system operating in the fire mode.

**Flow rates are with the pressurization operating in the fire mode and in standard units at 21°C (70°F) and one atmosphere.

***Leakage area of these spaces estimated to only one place because of high uncertainty of the low values of pressure difference and flow rate.

****Leakage area of this space not estimated because no pressure difference was detected.

Table 3. Dimensions of gaps around doors* at the VA Building

Floor	Middle Gap		Undercut		Average Gap of Top and Sides		Total Leakage Area	
	mm	in	mm	in	mm	in	m ²	ft ²
11	3.5	0.139	25	1.00	2.8	0.109	0.079	0.85
10	3.9	0.153	25	1.00	2.0	0.078	0.075	0.81
9	4.3	0.168	27	1.06	2.8	0.110	0.084	0.91
8	3.5	0.139	27	1.06	3.1	0.123	0.085	0.91
7	2.6	0.103	24	0.938	3.0	0.118	0.075	0.81
6	3.5	0.139	29	1.13	2.4	0.094	0.083	0.90
5	10	0.399	25	1.00	1.7	0.069	0.087	0.93
4	3.2	0.126	27	1.06	2.0	0.080	0.077	0.83
3	1.3	0.051	25	1.00	2.6	0.104	0.073	0.79
2	1.3	0.053	19	0.750	3.4	0.135	0.065	0.70

*each set of double doors is 84 in (2.13 m) high by 71 in (1.80 m) wide.

Table 4. Field test data of the staging areas at the Whipple Federal Office Building

Floor	Pressure Difference*		Pressurization Air**		Estimated Leakage Area Between Staging Area and Building	
	Pa	in H ₂ O	L/s	cfm	m ²	ft ²
6	3.7	0.015	170	350	0.042	0.45
5	6.2	0.025	170	370	0.052	0.56
4	8.2	0.033	180	390	0.045	0.48
3	7.0	0.028	170	370	0.051	0.55
2	6.2	0.025	160	340	0.051	0.55
B	8.0	0.032	150	310	0.061	0.66

*Pressure differences are from staging area to the building with pressurization system operating in the fire mode.

**Flow rates are with the pressurization operating in the fire mode and in standard units at 21°C (70°F) and one atmosphere.

Table 5. Field test data of the staging areas at the Toledo Federal Office Building

Floor	Pressure Difference*		Pressurization Air**		Estimated Leakage Area Between Staging Area and Building	
	Pa	in H ₂ O	L/s	cfm	m ²	ft ²
7	6.0	0.024	430	920	0.16	1.7
6	4.2	0.017	390	830	0.18	1.9
5	5.2	0.021	450	960	0.19	2.0
4	3.7	0.015	340	730	0.18	1.9
3	2.5	0.010	290	620	0.19	2.0
2	2.2	0.009	260	560	0.20	2.1

*Pressure differences are from staging area to the building with pressurization system operating in the fire mode.

**Flow rates are with the pressurization operating in the fire mode and in standard units at 21°C (70°F) and one atmosphere.

Table 6. Field test data of the staging areas at the Bemidji Federal Office Building

Floor	Pressure Difference*		Pressurization Air**		Vented Air**		Estimated Leakage Area Between Staging Area and Building	
	Pa	in H ₂ O	L/s	cfm	L/s	cfm	m ²	ft ²
4	12	0.048	740	1600	150	320	0.079	0.85
3	18	0.073	850	1800	150	320	0.090	0.97
2	11	0.045	730	1500	80	170	0.083	0.89
B	7.0	0.028	470	1000	30	60	0.071	0.76

*Pressure differences are from staging area to the building with pressurization system operating in the fire mode.

**Flow rates are with the pressurization operating in the fire mode and in standard units at 21°C (70°F) and one atmosphere.

Table 7. Field test data of the basement staging area at the Cohen Building

Pressure Difference*		Pressurization Air**		Vented Air**		Estimated Leakage Area*** Between Staging Area and Building	
Pa	in H ₂ O	L/s	cfm	L/s	cfm	m ²	ft ²
-0.7	-0.003	60	130	90	190	0.04	0.4

*Pressure differences are from staging area to the building with pressurization system operating in the fire mode.

**Flow rates are with the pressurization operating in the fire mode and in standard units at 21°C (70°F) and one atmosphere.

***Leakage area of this space estimated to only one place because of high uncertainty of the low values of pressure difference and flow rate.

Table 8. Dimensions of gaps around east doors* at Cohen Building

Floor	Middle Gap		Undercut		Average Gap of Top and Sides		Total Leakage Area	
	mm	in	mm	in	mm	in	m ²	ft ²
5	0.79	0.031	7.9	0.313	2.8	0.111	0.033	0.36
4	6.2	0.242	4.8	0.188	2.9	0.115	0.039	0.42
3	0.86	0.034	4.7	0.184	3.2	0.127	0.030	0.32
2	2.9	0.114	7.9	0.313	3.3	0.131	0.041	0.44

*each set of double doors is 84 in (2.13 m) high by 71 in (1.80 m) wide.

Table 9. Dimensions of gaps around west doors* at Cohen Building

Floor	Middle Gap		Undercut		Average Gap of Top and Sides		Total Leakage Area	
	mm	in	mm	in	mm	in	m ²	ft ²
5	0.89	0.035	9.3	0.366	2.5	0.100	0.034	0.37
4	1.2	0.046	11.	0.438	2.7	0.108	0.039	0.42
3	3.0	0.116	7.9	0.313	3.2	0.126	0.040	0.43
2	0.94	0.037	8.7	0.344	2.5	0.100	0.030	0.36

*each set of double doors is 84 in (2.13 m) high by 71 in (1.80 m) wide.

Table 10. Field test data of the staging areas at the Pension Building

Staging Area*	Pressure Difference**		Pressurization Air***		Vented Air***		Estimated Leakage Area Between Staging Area and Building****	
	Pa	in H ₂ O	L/s	cfm	L/s	cfm	m ²	ft ²
Fl 4 W	12	0.050	190	400	0	0	0.064	0.69
Fl 4 E	13	0.051	190	400	9	20	0.060	0.65
Fl 3 W	5	0.022	180	380	0	0	0.1	1.
Fl 3 E	4	0.015	150	320	0	0	0.1	1.
Fl 2 W	3	0.013	200	410	0	0	0.1	1.
Fl 2 E	5	0.020	200	430	0	0	0.1	1.

*Abbreviations are: Fl for floor, W for west, and E for east.

**Pressure differences are from staging area to the building with pressurization system operating in the fire mode.

***Flow rates are with the pressurization operating in the fire mode and in standard units at 21°C (70°F) and one atmosphere.

****Leakage area of staging areas on floors 2 and 3 are estimated to only one place because of high uncertainty of the low values of pressure difference and flow rate.

Table 11. Tenability limits

Cause	Incapacitation Level	Lethal Level
Temperature ¹	65°C (149°F)	100°C (212°F)
Toxic Gases ²	0.50	1.00

¹This is the temperature of the surroundings. In addition, a temperature of 200°C (390°F) above the head level is considered lethal. Head level is taken to be 1.52 m (5.0 ft) above the floor.

²Fractional Exposure Dose (FED) due to CO, CO₂, and O₂.

Table 12. Fires used as basis for analysis in this report

Description	Peak Energy Release Rate (kW)	Approximate Time to Peaks (min)
1. Module Group 1: Collection of 5 office module units of the type in item 3, Single Module 1	10,000	1,300 (22)
2. Module Group 2: Collection of 5 office module units of the type in item 4, Single Module 2	25,000	500 (8.3)
3. Single Module 1: L shaped office module with moveable partitions	1,800	360 (6)
4. Single Module 2: U shaped systems furniture office module	7,000	480 (8)
5. Module Group 2 with standard automatic sprinklers	400	330 (5.5)
6. Module Group 2 with quick response automatic sprinklers	265	145 (2.4)
7. Smoldering Fire: Simulation of smoldering fire in upholstered chair	75	2700 (45)
8. Open Burning Fire to 25 MW: Simulation of fire involving a large stage and/or display in the atrium (Used in analysis of pension building)	25,000	1200 (20)
9. Open Burning Fire to 10 MW (Used in analysis of pension building)	10,000	720 (12)
10. Open Burning Fire to 5 MW: (Used in analysis of pension building)	5,000	500 (8.3)

Table 13. Conditions Exposing Staging Area

Building and Location	Approx. Temp. °C (°F)	Oxygen % volume	Carbon Monoxide ppm	Carbon dioxide % volume	Smoke level m(ft)
VA Building at staging area	30 (85)	19	< 100	< 1	0
Whipple Building at staging area	40 (100)	18	< 100	< 3	0
Whipple Building in fire room	115 (240) ^a	18	< 100	< 3	0
Bemidji Building at staging area	540 (1000)	< 1	35000	9	NEAR 0
Bemidji Building in fire room	815 (1500)	< 1	38000	9	1.4 (4.6)
Toledo Building open plan at staging area	880 (1650)	< 1	38000	9	1.4 (4.6)
Toledo Building corridor plan at staging area	450 (1000)	< 1	35000	9	near 0
Cohen Building at separation doors	815 (1500)	< 1	38000	9	near 0
Pension Building 25 MW fire at 3rd floor staging area	106 (223) at 45 min	> 18	< 100	1.4	3(10)

^aoccurs at approximately 2 minutes into fire, just before operation of sprinkler head. Smoke layer is about 1.2 m (4 ft) above floor at this time. The gas temperature drops as soon as sprinkler flow occurs.

Table 14. Estimated egress travel time in VA Building

Element	Able Persons	Fast Disabled Person	Slow Disabled Person
No. of persons	120	1 to 10	1 to 10
No. of exit doors	4	2	2
Travel speed m/s (ft/min)	1.27 (250)	1.27 (250)	0.46 (90)
Stair speed m/s (ft/min)	0.2 (40)	NA	NA
Door flow rate persons/min	60	NA	NA
Stair flow rate persons/m/s (persons/ft/min)	1 (18.288)	NA	NA
Level exit travel distance m (ft)	38.4 126	128 (420)	128 (420)
Movement time min	0.5	1.7	4.7
Resting time min			8.0
Total time min	0.5	1.7	12.7

Table 15. Time factors in reaching staging areas in VA Building

Ability of Evacuee	Time Available	Time Required (min)	Margin
Able	Unlimited	< 1	Unlimited
Fast Disabled ^a		< 2	Unlimited
Slow Disabled ^b		12.7	Unlimited

a. Persons who can proceed on level floors at the speed expected of able persons but who can not traverse stairs. Travel speed on level surfaces calculated at 76 m/s (250 ft/min)

b. Slow moving persons who can proceed on level floors only at a speed much less than that expected of able persons, require frequent rest periods, and can not traverse stairs. Travel speed on level surfaces calculated at 27 m/s (90 ft/min) with 2 minutes rest at the end of each 30 m (100 ft) of travel. These travel factors are those recommended by the regulations of the Department of Justice for the implementation of the Americans with Disabilities Act.

Notes:

1. If fire initiates in the open plan space the peak temperature rises momentarily to 60°C (140°F) just prior to sprinkler operation. Once sprinkler flow is established the temperature drops rapidly to an estimated 30°C (85°F).
2. If fire initiates in a small 42 m² (450 ft.²) room peak temperature in that room momentarily rises to 82°C (180°F) at about 1.5 minutes after initial flaming. Evacuation of that room is desirable but not required for survival. Experience has shown that such time is sufficient.
3. Conditions in the corridor (oxygen > 19%, carbon monoxide < 100 ppm and temperature below head height < 40°C (100°F)) remain tenable for the duration of the exposure.

Table 16. Estimated egress travel time in Whipple Building

Element	Able Persons	Fast Disabled Person	Slow Disabled Person
No. of persons	340	1 to 10	1 to 10
No. of exit doors	5	1	1
Travel speed m/s (ft/min)	1.27 (250)	1.27 (250)	0.46 (90)
Stair speed m/s (ft/min)	0.2 (40)	NA	NA
Door flow rate persons/min	60	NA	NA
Stair flow rate persons/m/s (persons/ft/min)	1 (18.288)	NA	NA
Level exit travel distance m (ft)	36.5 (120)	64 (210)	64 (210)
Movement time min	1.1	0.8	2.3
Resting time min			4.0
Total time min	1.1	0.8	6.3

Table 17. Time factors in reaching staging areas in Whipple Building

Ability of Evacuee	Time Available	Time Required	Margin
Able	Unlimited	0.8 min	Unlimited
Fast Disabled		0.8 min	Unlimited
Slow Disabled		6.3 min	Unlimited

notes:

1. Temperature in room of origin is calculated to briefly rise to 115°C (240°F) at about 2 minutes after initial flaming. Evacuation of that room will be required. Experience has shown that such time is sufficient.
2. Conditions in the corridor (oxygen > 19%, carbon monoxide < 100 ppm and temperature below head height < 40°C (100°F)) remain tenable for the duration of the exposure.

Table 18. Estimated egress travel time in Bemidji Federal Office Building

Element	Able Persons	Fast Disabled Person	Slow Disabled Person
No. of persons	56	1 to 3	1 to 3
No. of exit doors	2	1	1
Travel speed m/s (ft/min)	1.27 (250)	1.27 (250)	0.46 (90)
Stair speed m/s (ft/min)	0.2 (40)	NA	NA
Door flow rate persons/min	60	NA	NA
Stair flow rate persons/m/s (persons/ft/min)	1 (18.288)	NA	NA
Level exit travel distance m (ft)	19.8 (65)	41 (135)	41 (135)
Movement time min	0.3	0.5	1.5
Resting time min			2.0
Total time min	0.3	0.5	3.5

Table 19. Time factors in reaching staging areas in Bemidji Building

Ability of Evacuee	Time Available	Time Required	Margin
Able	3.5 (0.5 min*)	0.3 min	3.2 min (0.2 min*)
Fast Disabled		0.5 min	3 min (0 min*)
Slow Disabled		3.5 min	0 min (-3 min*)

Notes:

1. Analysis assumes a corridor 1.8 m (6 ft) wide 25 m (83 ft) long connecting the west stairwells to the staging area. Fire is assumed to occur in a 42 m² (450 ft²) office with the door to the corridor open.

2. This analysis is based on a flashed over fire in a room opening on the corridor. The analysis assumes that the alarm will be given within 3 minutes of initial flaming and that flashover will occur at 6 minutes after initial flaming.

3. The times indicated by an asterisk (*) are included to demonstrate the situation if fire is not alarmed until the moment of flashover. This type of situation has been involved in the few fatal incidents that have occurred in occupied office buildings.

4. Time required by able persons assumes 60 persons exiting through the two stairwells. It assumes that the evacuees will have free access to the stairwells (i.e. no congestion from other floors).

5. Time required for disabled persons assumes that such persons will have free access routes to the staging area and will not be delayed by able persons attempting to reach the stairs.

Table 20. Time to untenable conditions in staging area in basement of Bemidji Building

Building Conditions	Still Air (lethal/ incapacitating)	Prevailing Wind of 4 m/s (9 mph) (lethal/ incapacitating)	Strong Wind of 18 m/s (40 mph) (lethal/ incapacitating)
540°C (1000°F) Exposure; smoke control system operating	Never Never	Never Never	< 1 min heat
540°C (1000°F) Exposure; smoke control system not operating	1 min heat < 1 min heat	< 1 min heat	< 1 min heat
120°C (250°F) Exposure; smoke control system operating	Never Never	Never Never	4 min toxic 3 min toxic
120°C (250°F) Exposure; smoke control system not operating	5 min toxic 3 min heat	4 min toxic 2 min heat	< 1 min heat

Note: Never indicates that untenable conditions are never reached.

Table 21. Estimated egress travel time in Toledo Federal Office Building

Element	Able Persons	Fast Disabled Person	Slow Disabled Person
No. of persons	140	1 to 10	1 to 10
No. of exit doors	2	2	2
Travel speed m/s (ft/min)	1.27 (250)	1.27 (250)	0.46 (90)
Stair speed m/s (ft/min)	0.2 (40)	NA	NA
Door flow rate persons/min	60	NA	NA
Stair flow rate persons/m/s (persons/ft/min)	1 (18.288)	NA	NA
Level exit travel distance m (ft)	58 (190)	46 (150)	46 (150)
Movement time min	1.2	0.6	1.7
Resting time min			2.0
Total time min	1.2	0.6	3.7

Table 22. Time factors in reaching staging areas on open plan floor in Toledo Building

Ability of Evacuee	Time Available	Time Required	Margin
Able	4.5 min	1.2 min	3.3 min
Fast Disabled		0.6 min	3.9 min
Slow Disabled		3.7 min	0.8 min

Notes:

1. Time limit based on alarm at 1.5 minutes following flame initiation (fire size 200 kW producing a flame about 1.5 m (5 ft) high) and descent of hot gas in excess of 93°C (200°F) below 1.5 m (5 ft) level by 6 minutes calculations indicate very rapid decent at that time to less than 1 m (3 ft)
2. At time of descent of hot gas, oxygen concentration in the smoke is still above 18% and carbon monoxide levels are less than 100 ppm.
3. Time required by able persons assumes 140 persons exiting through the two stairwells. It assumes that the evacuees will have free access to the stairwells (i.e. no congestion from other floors).
4. Time required for disabled persons assumes that such persons will have free access routes to the staging area and will not be delayed by able persons attempting to reach the stairs.
5. As the time available approaches zero conditions in the space will be obviously dangerous and frightening.
6. The values in the table are based on the fire curve for module group 2 (25 MW peak.) Test calculations using less severe fires indicate that the same results would be obtained if the fire curve is based on module group 1 (10 MW peak.) The time available would increase to about 6 minutes using the fire curve for single module 2 (7 MW peak). Given the single module 1 fire curve (1.8 MW peak) the smoke layer would remain above head height for about 16 min, never descending below about 1.2 m (4 ft) and peaking at about 90°C (200°F). This condition is marginally tenable for an extended period of time.

Table 23. Time factors in reaching staging areas on corridor plan floor in Toledo Building

Ability of Evacuee	Time Available	Time Required	Margin
Able	4.7 min (1.7 min*)	1.2 min	3.5 min (0.5 min*)
Fast Disabled		0.6 min	4.1 min (1.1 min*)
Slow Disabled		3.7 min	1 min (-2.0 min*)

Notes:

1. Analysis assumes a corridor 2.4 m (8 ft) wide 59 m (194 ft) long connecting the two stairwells. The fire is assumed to occur in a 42 m² (450 ft²) office with the door to the corridor open.

2. This analysis is based on a flashed over fire in a room opening on the corridor. The analysis assumes that the alarm will be given within 3 minutes of initial flaming and that flashover will occur at 6 minutes after initial flaming.

3. The times indicated by an asterisk (*) are include to demonstrate the situation if fire is not alarmed until the moment of flashover. This type of situation has been involved in the few fatal incidents that have occurred in occupied office buildings.

4. Time required by able persons assumes 140 persons exiting through the two stairwells. It assumes that the evacuees will have free access to the stairwells (i.e. no congestion from other floors).

5. Time required for disabled persons assumes that such persons will have free access routes to the staging area and will not be delayed by able persons attempting to reach the stairs.

Table 24. Time to untenable conditions in staging area on second floor of Toledo Building

Building Conditions	Still Air (lethal/ incapacitating)	Prevailing Wind of 4 m/s (9 mph) (lethal/ incapacitating)	Strong Wind of 18 m/s (40 mph) (lethal/ incapacitating)
890°C (1600°F) Exposure; smoke control system operating	12 min toxic 1½ min heat	< 1 min heat	< 1 min heat
890°C (1600°F) Exposure; smoke control system not operating	< 1 min heat	< 1 min heat	< 1 min heat
540°C (1000°F) Outside the staging area; smoke control system operating	13 min toxic 5 min heat	3 min heat < 1 min heat	< 1 min heat
540°C (1000°F) Outside the staging area; smoke control system not operating	1 min heat < 1 min heat	< 1 min heat	< 1 min heat
120°C (250°F) Outside the staging area; smoke control system operating	21 min toxic 13 min toxic	7 min toxic 5 min toxic	< 1 min heat
120°C (250°F) Outside the staging area; smoke control system not operating	4 min toxic 3 min toxic	3 min toxic 2 min heat	< 1 min heat

Table 25. Estimated egress travel time in Cohen Building (East or West Wing)

Element	Able Persons	Fast Disabled Person	Slow Disabled Person
No. of persons	100	1 to 10	1 to 10
No. of exit doors	2	2	2
Travel speed m/s (ft/min)	1.27 (250)	1.27 (250)	0.46 (90)
Stair speed m/s (ft/min)	0.2 (40)	NA	NA
Door flow rate persons/min	60	NA	NA
Stair flow rate persons m/s (persons/ft/min)	1 (18.288)	NA	NA
Level exit travel distance m (ft)	61 (200)	61 (200)	61 (200)
Movement time min	0.8	0.8	2.2
Resting time min			4.0
Total time min	0.8	0.8	6.2

Table 26. Time factors in reaching staging areas on corridor plan floor in Cohen Building

Ability of Evacuee	Time Available	Time Required	Margin
Able	5 min (3 min*)	0.8 min	4.2 min (2.2 min*)
Fast Disabled		0.8 min	4.2 min (2.2 min*)
Slow Disabled		6.2 min	-1.2 min (-3.2 min*)

Notes:

1. This analysis is based on a flashed over fire in a room opening on to the corridor of the wing. The analysis assumes that the alarm will be given within 3 minutes of initial flaming and that flashover will occur at 6 minutes after initial flaming.
2. The values shown with an asterisk (*) are those that apply if the fire is between the evacuees and the exit. These all are based on evacuees being unable to pass the open door to the flashed over room.
3. Each of the wings is a extensive dead end section of the building. All evacuees must come to the central corridor to pass the fire doors separating the wing from the main portion of the building. All exit stairs are in the main portion of the building (i.e. between the recently installed fire doors).
4. After flashover the smoke front will not decent to head height for about 2 minutes. If the evacuees do not have to pass within about 23 m (75 ft) of the fire room they will not be exposed to painful radiation from the flame and hot smoke in that area.
5. The oxygen concentration in the post flashover smoke front will drop close to zero, the carbon monoxide will rise to about 3.5 to 4% (35,000 to 40,000 ppm) and the carbon dioxide concentration will rise to about 10%. If persons take refuge in their office their safety will depend on the tightness of that space and the resultant rate of leakage from the smoke filled corridor into that space.
6. Fires in the main portion will react similarly, however the wide and extensive corridor system will both distribute the smoke over a larger and more extensive system of corridors. It is likely that slower evacuees will find one route inaccessible but other available.

Table 27. Time to untenable conditions in staging area on second floor of Cohen Building

Building Conditions	Still Air (lethal/ incapacitating)	Prevailing Wind of 4 m/s (9 mph) (lethal/ incapacitating)	Strong Wind of 18 m/s (40 mph) (lethal/ incapacitating)
815°C (1500°F) Exposure; no smoke control system present	26 min heat	25 min heat	11 min heat
	9 min heat	8 min heat	4 min heat
120°C (250°F) Exposure; no smoke control system present	46 min toxic	32 min toxic	22 min toxic
	36 min toxic	26 min toxic	17 min toxic

Table 28. Time to untenable conditions in staging area in basement of Cohen Building

Building Conditions	Still Air (lethal/ incapacitating)	Prevailing Wind of 5.8 m/s (13 mph) (Lethal/ incapacitating)	Strong Wind of 18 m/s (40 mph) (lethal/ incapacitating)
815°C (1500°F) Exposure; smoke control system operating	Never	Never	Never
	Never	Never	Never
815°C (1500°F) Exposure; smoke control system not operating	16 min heat	16 min heat	16 min heat
	8 min heat	8 min heat	8 min heat
120°C (250°F) Exposure; smoke control system not operating	Never	Never	Never
	Never	Never	Never
120°C (250°F) Exposure; smoke control system not operating	29 min toxic	29 min toxic	29 min toxic
	22 min toxic	22 min toxic	22 min toxic

Note: Never indicates that untenable conditions are never reached.

Table 29. Estimated egress travel time in Pension Building

Element	Able Persons	Fast Disabled Person	Slow Disabled Person
No. of persons	50	1 to 10	1 to 10
No. of exit doors	4	2	2
Travel speed m/s (ft/min)	1.27 (250)	1.27 (250)	0.46 (90)
Stair speed m/s (ft/min)	0.2 (40)	NA	NA
Door flow rate persons/min	60	NA	NA
Stair flow rate persons/m/s (persons/ft/min)	1 (18.288)	NA	NA
Level exit travel distance m (ft)	88 (290)	91 (300)	91 (300)
Movement time min	2.2	1.2	3.2
Resting time min			4.0
Total time min	2.2	1.2	7.2

Table 30. Time factors in reaching staging areas on corridor plan floor in Pension Building given a 25 MW fire in atrium

Ability of evacuee	Time Available	Time Required	Margin
Able	25 min	2.2 min	Over 22 min
Fast Disabled		1.2 min	Almost 24 min
Slow Disabled		7.2 min	Almost 20 min

Notes:

1. First untenable condition is temperature. Time available is based on smoke temperature of 82°C(180°F). It also assumes that the alarm will be given 2 minutes after first flame. At that time the fire produces about 200 kW and a flame about 1.5 m (5 ft) High.

2. Time required based on a travel distance from the most remote position to the staging area of 91 m (290 ft). Since the stairs in this building are not enclosed, the time for able persons is based on the distance to the nearest stairs, decent of those stairs, and travel on the first floor to the nearest exit.

3. Because of the simple configuration of this building smoke obscuration was not considered as a critical factor. The calculation, however, indicate that vision would be reduced to about 15 m (50 ft) in about 20 minutes from flame initiation.

Table 31. Impact of Smoldering Fires in Different Buildings

Building	Smoke Level m (ft)	Approx. Temp. °C (°F)	Oxygen % volume	Carbon Monoxide ppm	Carbon Dioxide % volume
VA Building	1.4 (4.7)	27 (80)	> 20	< 400	< 0.25
Whipple Building	0.2 (0.4)	46 (115)	> 19	< 1000	< 1
Bemidji Building	0.05 (0.1)	55 (130)	> 18	< 2000	< 2
Toledo Building (corridor floor)	0.5 (1.7)	35 (95)	> 20	< 1000	< 0.5
Toledo Building (open plan floor)	1.7 (5.6)	26 (79)	> 20	< 300	0.2
Cohen Building (north wing)	0.4 (1.4)	35 (96)	20	< 1000	0.5
Pension Building	21 (43)	21 (70)	21	< 100	< 0.2
Closed 42 m ² (450 ft ²) room in any building	0 (0)	72 (160)	> 15	< 5000	< 4

Table 32. Minimum air supply needed to maintain smoke free conditions in the staging area

Conditions	Measured Air Delivery Rate		Minimum Air Flow Rate to Maintain Smoke-free Conditions	
	L/s	scfm	L/s	scfm
Bemidji Building basement				
540°C (1000°F) fire 18 m/s wind	470	1000	1,300	2,700
540°C (1000°F) fire still air	470	1000	0	0
Cohen Building basement				
815°C (1500°F) fire 18 m/s wind	190	400 ^a	22	46
815°C (1500°F) fire still air	190	400 ^a	22	46
Toledo Building 2nd floor				
900°C (1650°F) fire 18 m/s wind	260	560	3,200	6,800
900°C (1650°F) fire still air	260	560	940	2,000

a. This is an estimated flow rate. The smoke control system for this staging area is to be renovated. The flow rate indicated is that estimated for the post renovation capacity.

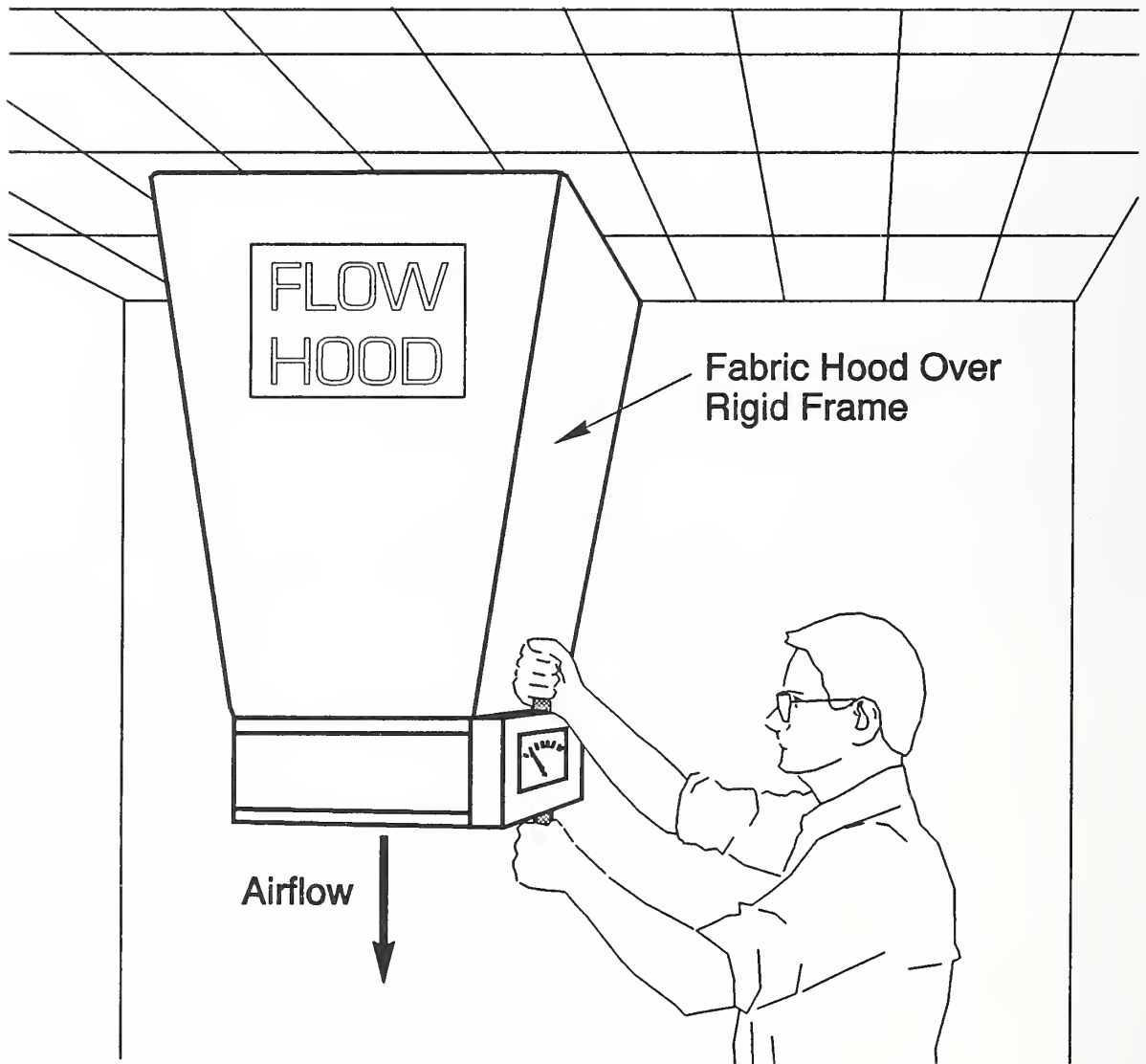

Figure 1. Flow hood for measuring volumetric flow

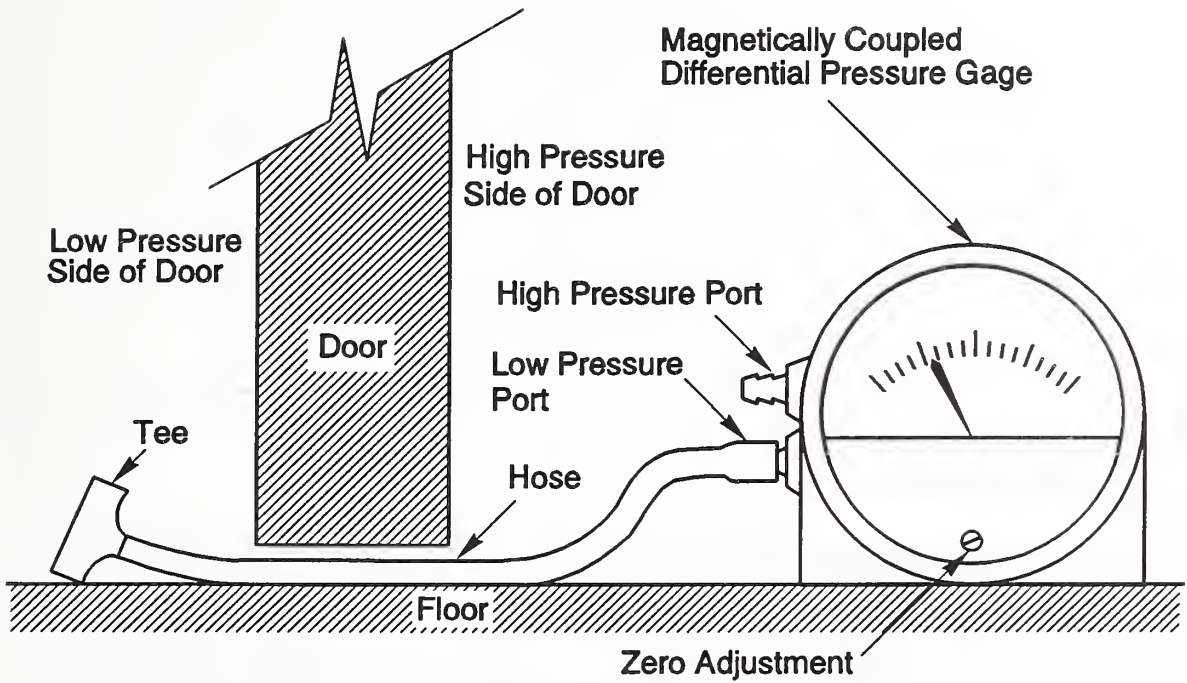
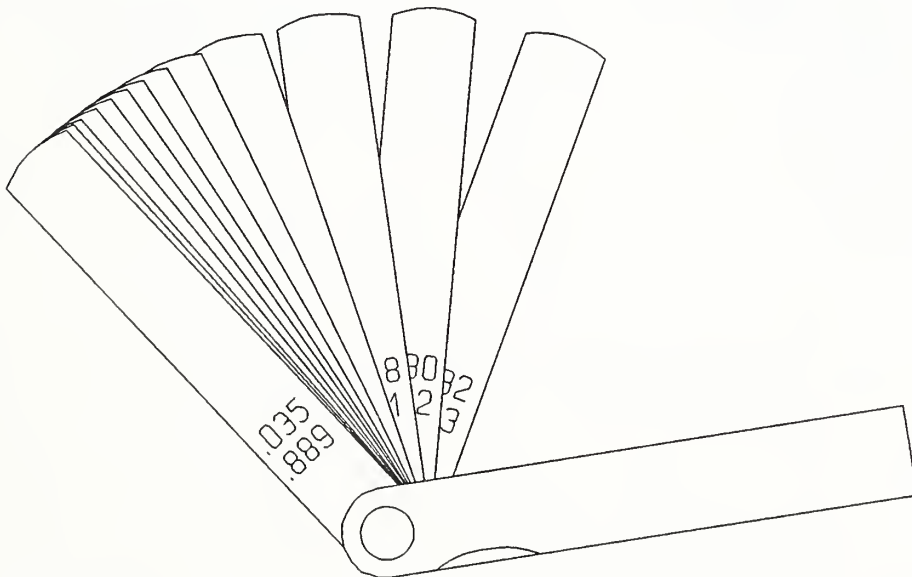
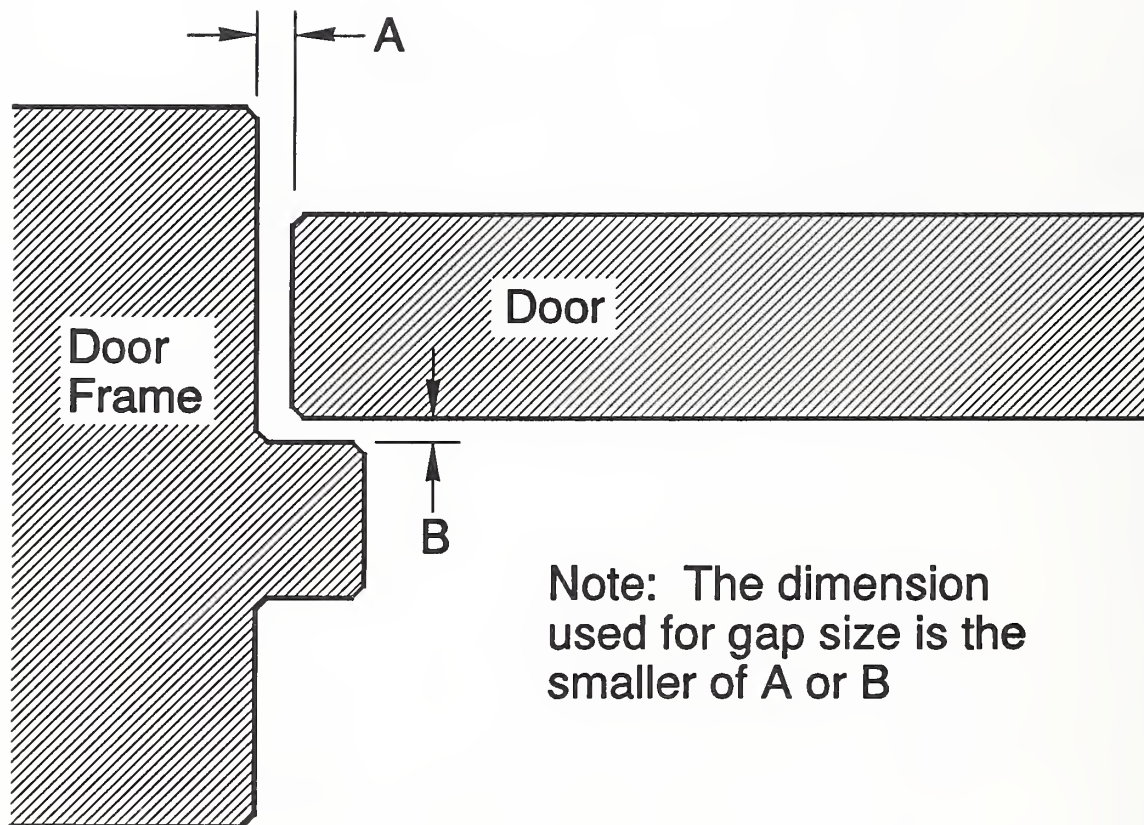

Figure 2. Set-up for measuring pressure difference across a door





Note: The dimension used for gap size is the smaller of A or B

Figure 4. Gap between door and door frame

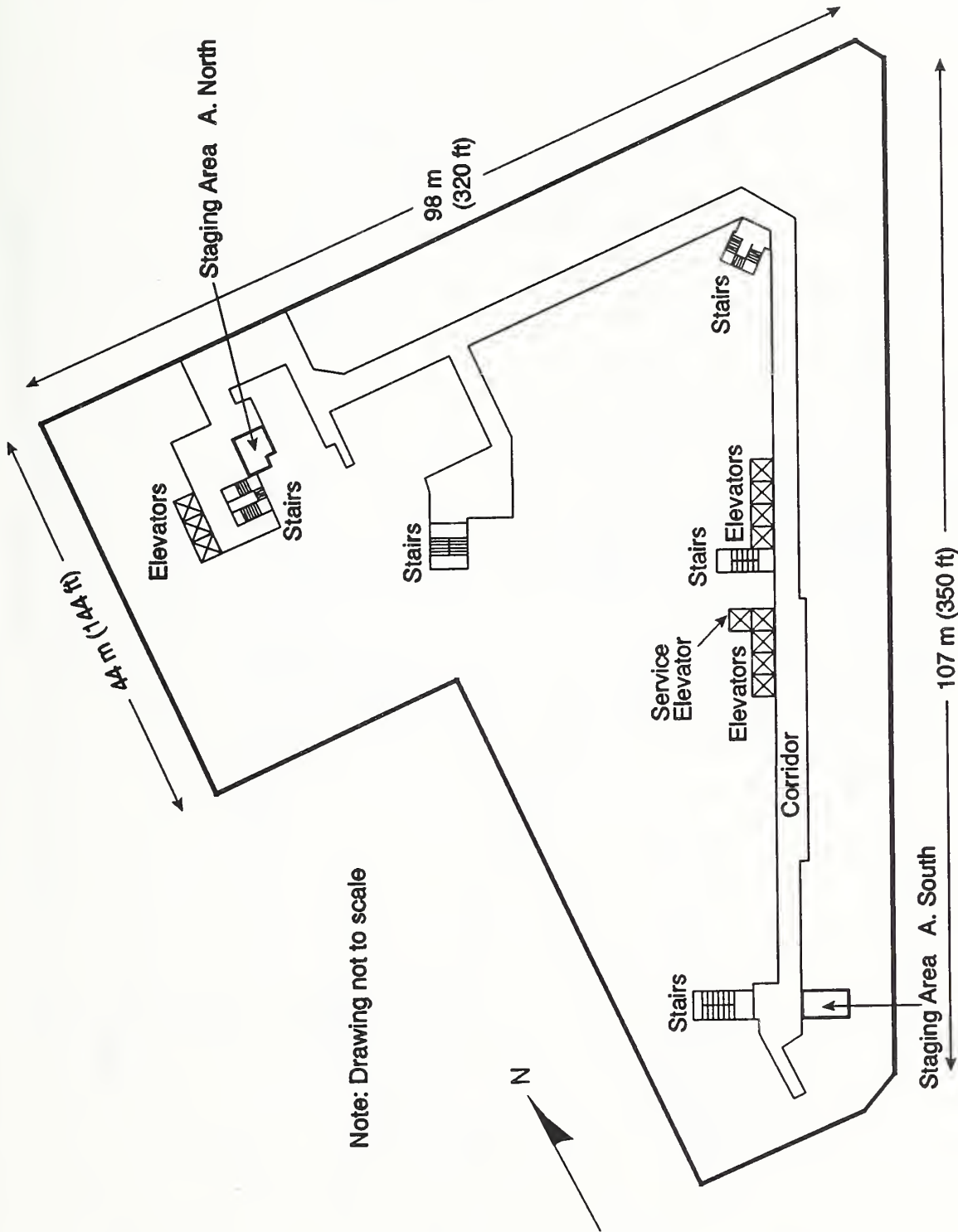
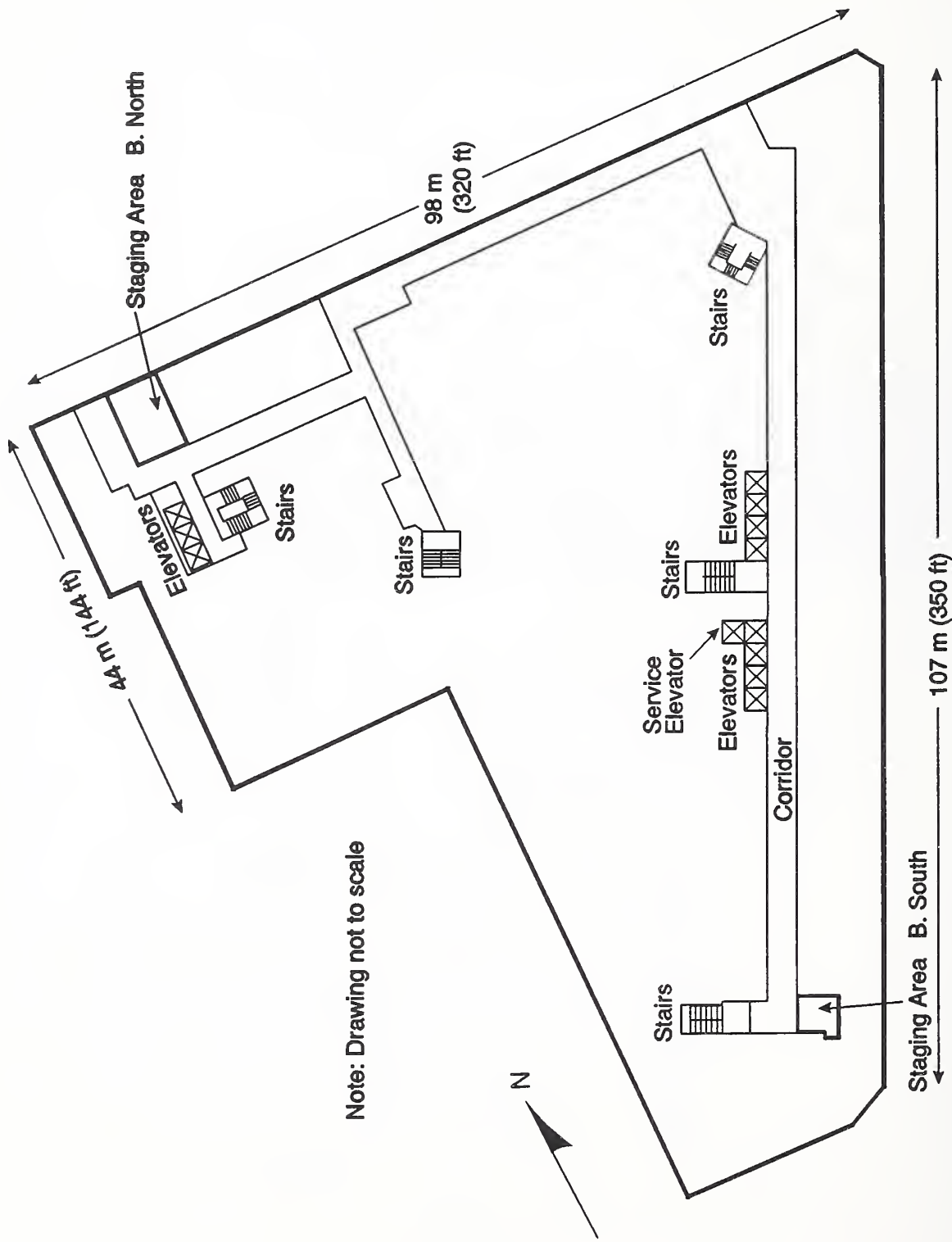
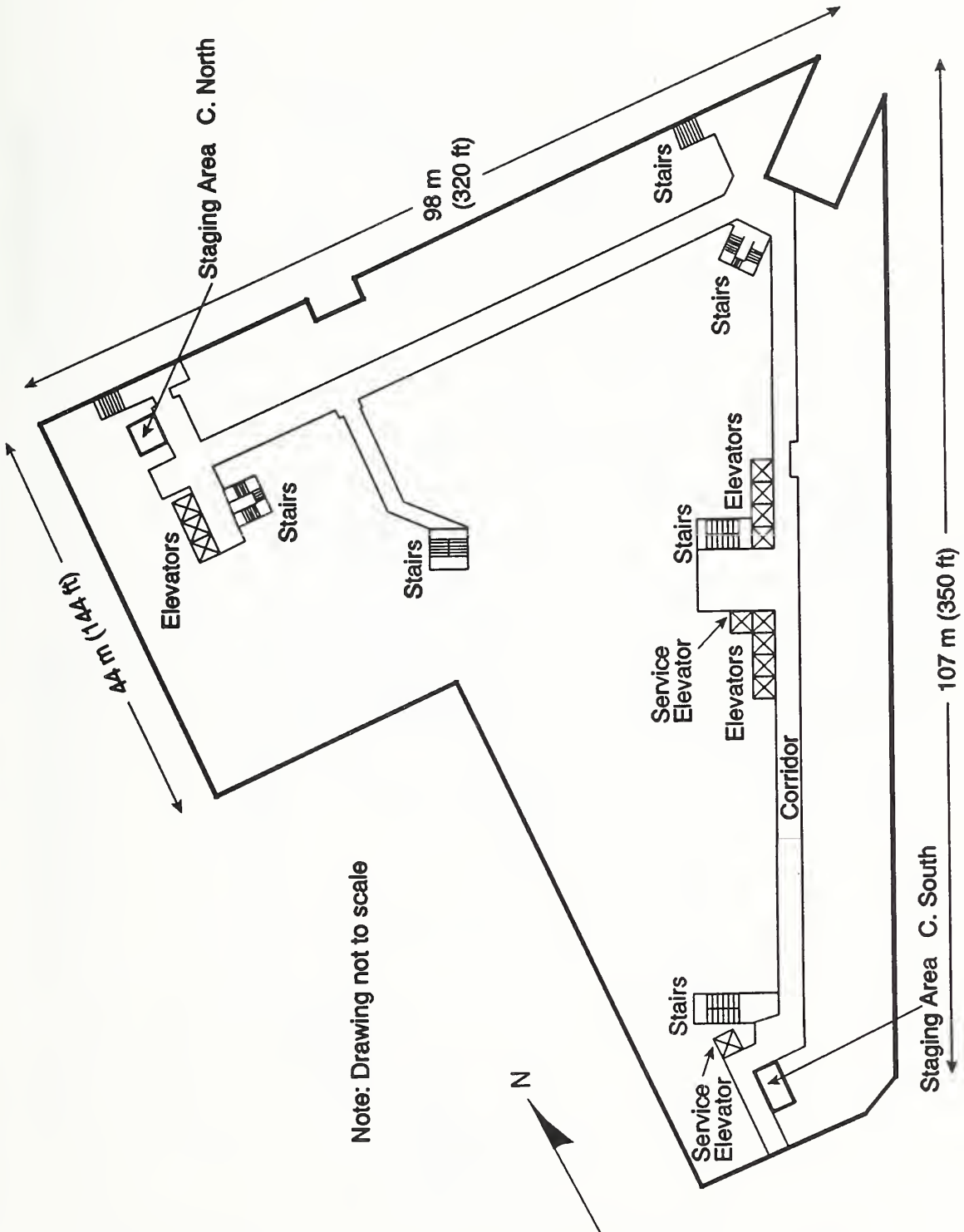

Figure 5. Basement A plan of the Department of Veterans Affairs Building



Note: Drawing not to scale

Figure 6. Basement B plan of the Department of Veterans Affairs Building



Note: Drawing not to scale

Figure 7. Basement C plan of the Department of Veterans Affairs Building

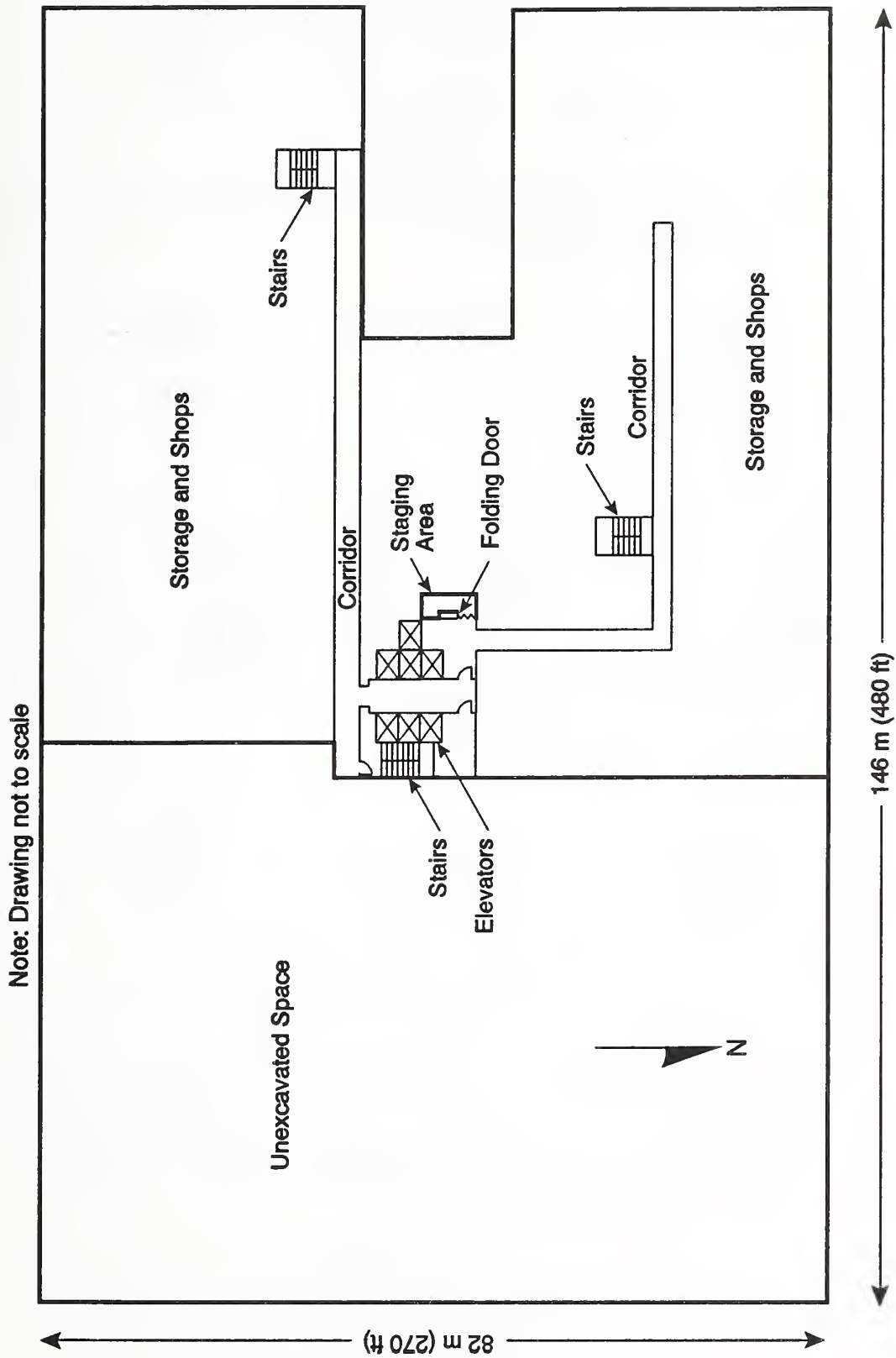

Figure 9. Basement plan of the Whipple Federal Office Building

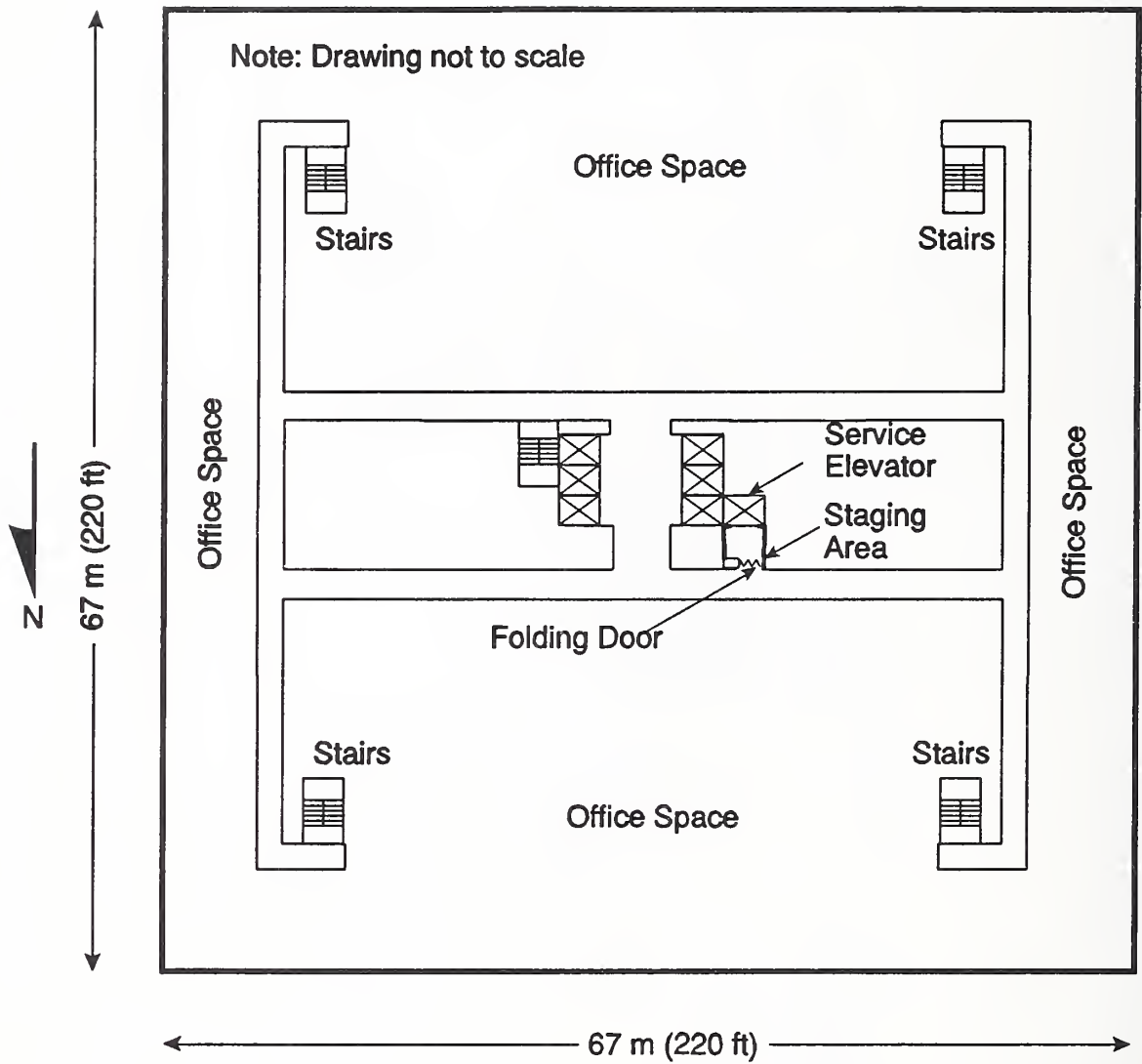

Figure 10. Typical plan of floors 2 through 6 of the Whipple Federal Office Building

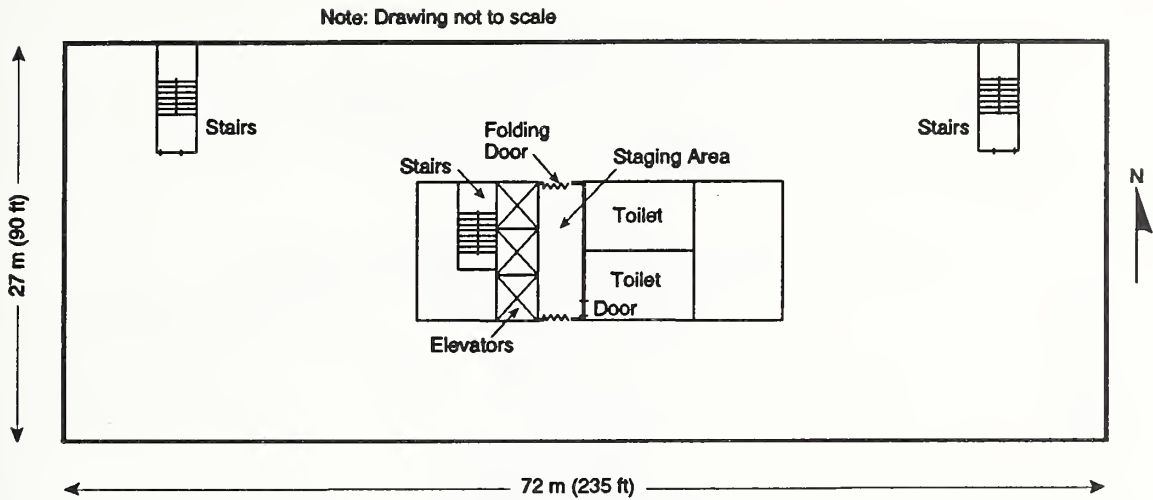

Figure 11. Typical plan of floors 2 through 7 of the Toledo Federal Office Building

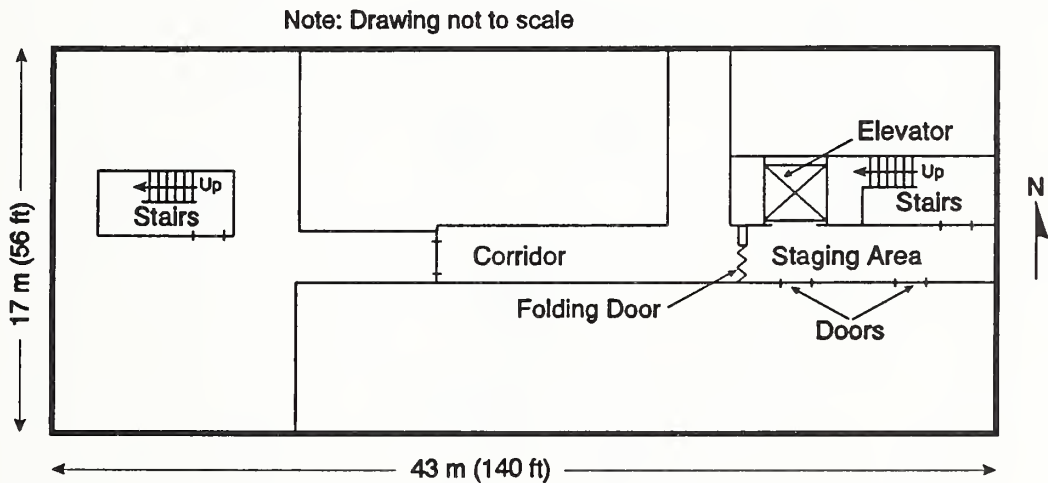

Figure 12. Basement plan of the Bemidji Federal Office Building

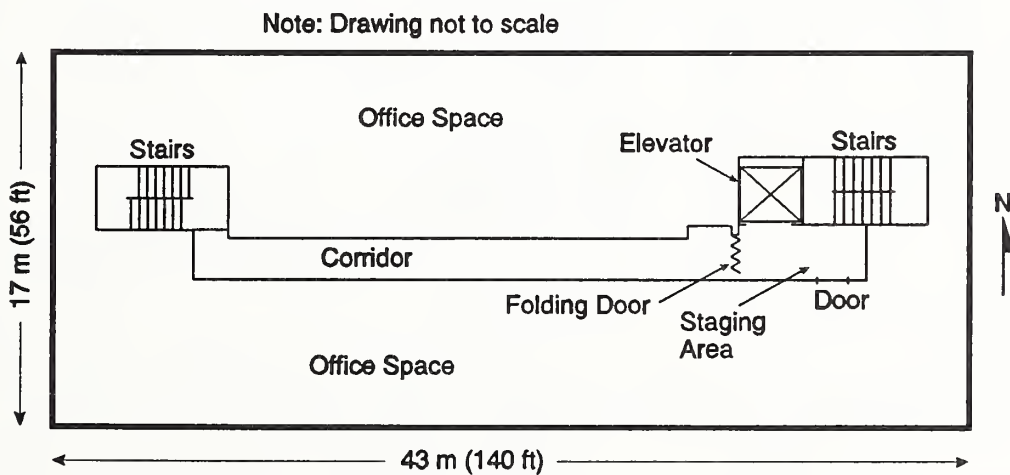

Figure 13. Typical plan of floors 2, 3 and 4 of the Bemidji Federal Office Building

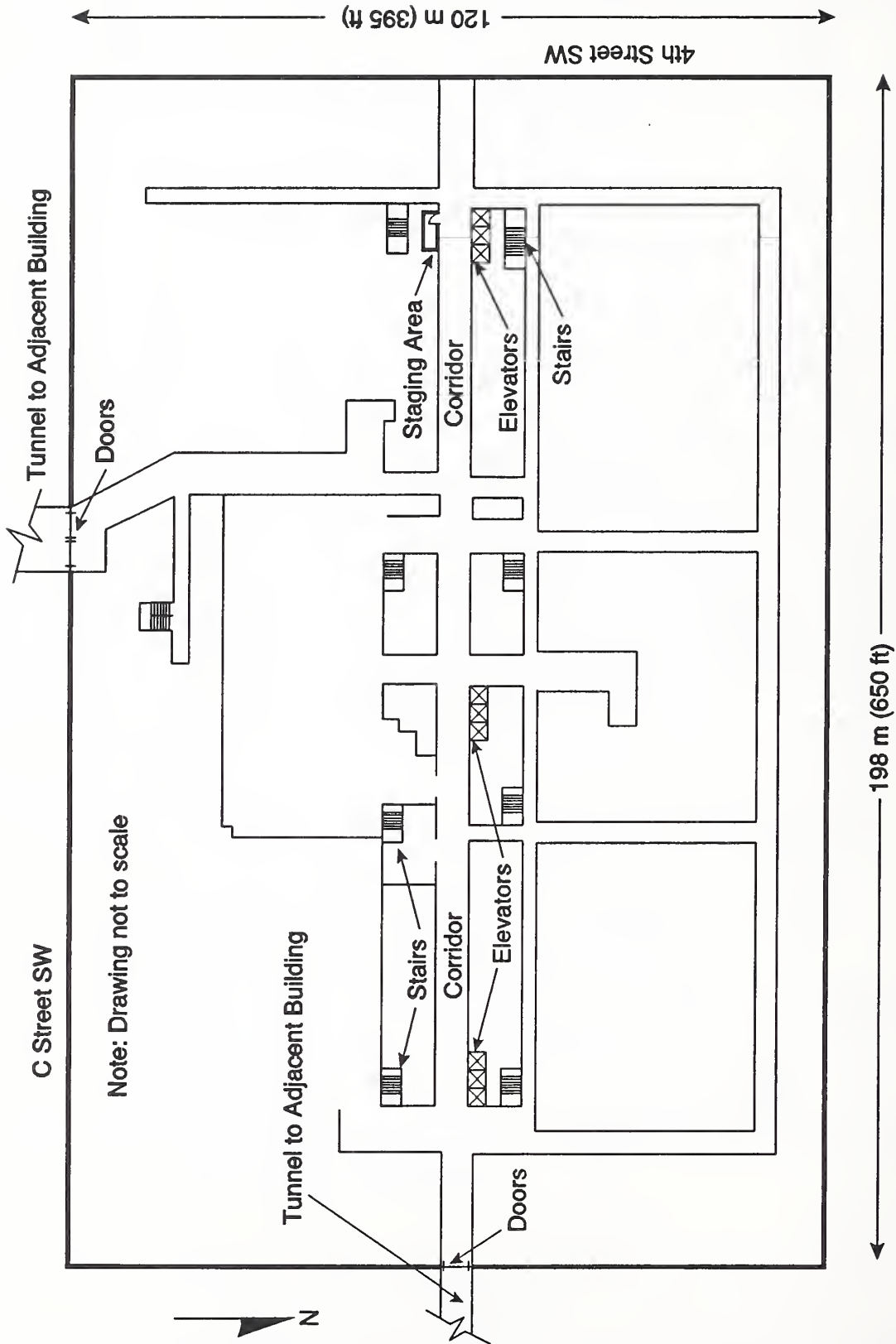

Figure 14. Basement Plan of the Cohen Building

Notes: 1. Drawing not to scale

2. During the site visits, some openings were observed in the walls for fire and smoke compartmentation, but efforts are underway to correct this.

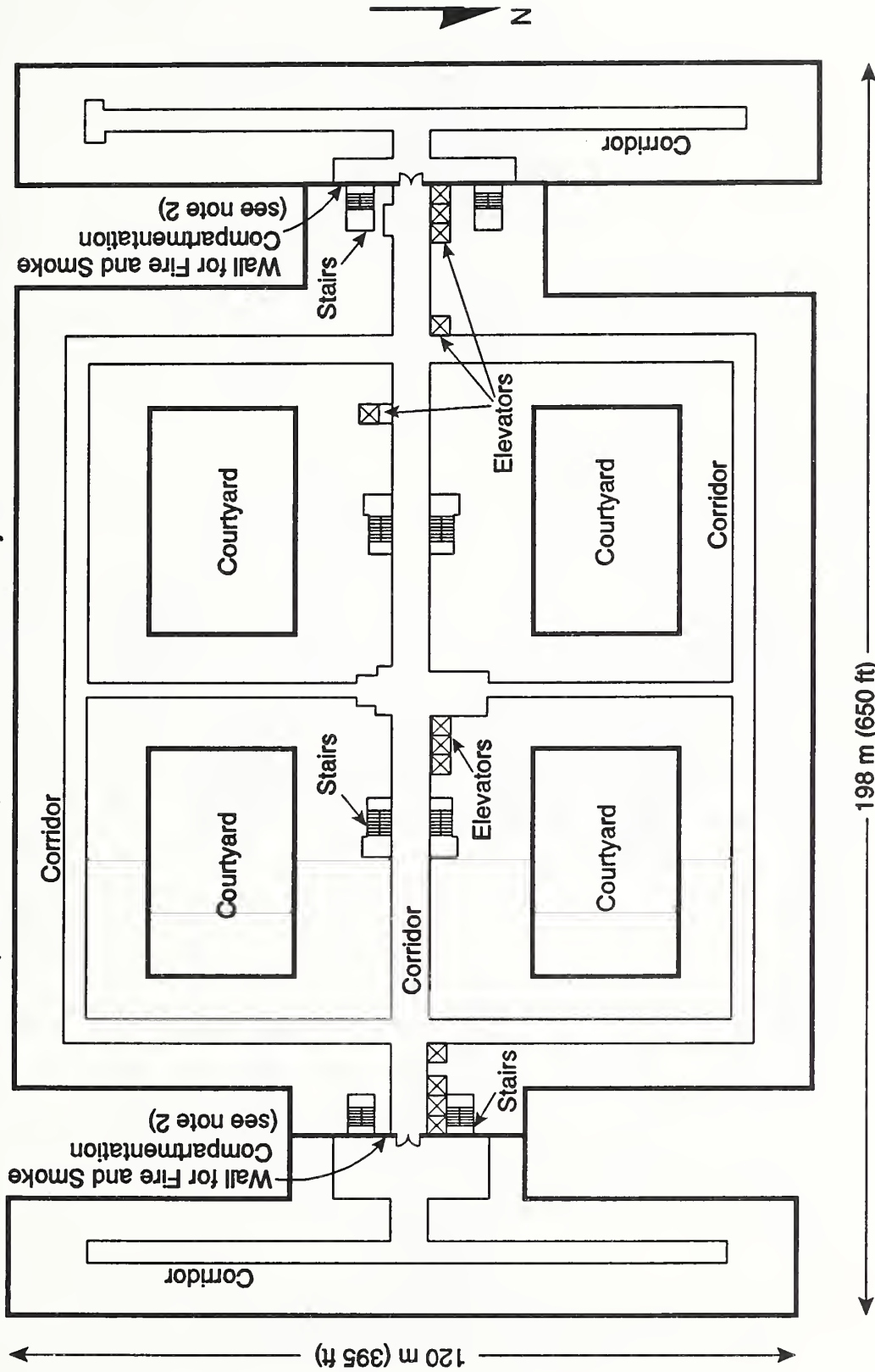

Figure 15. Typical plan of floors 2 to 5 of the Cohen Building

Note: Drawing not to scale

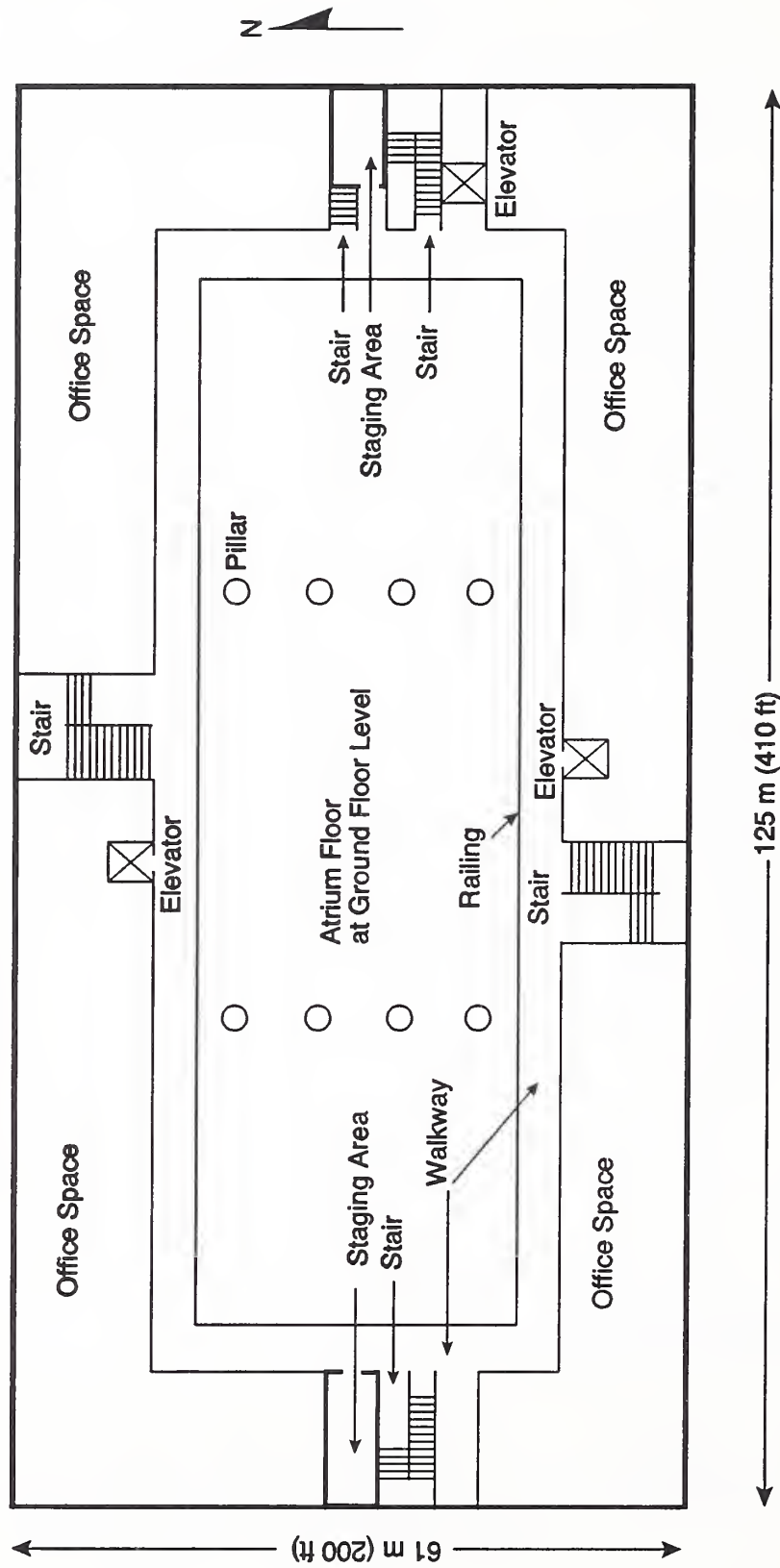

Figure 16. Plan of floor 2 of the Pension Building

Note: Drawing not to scale

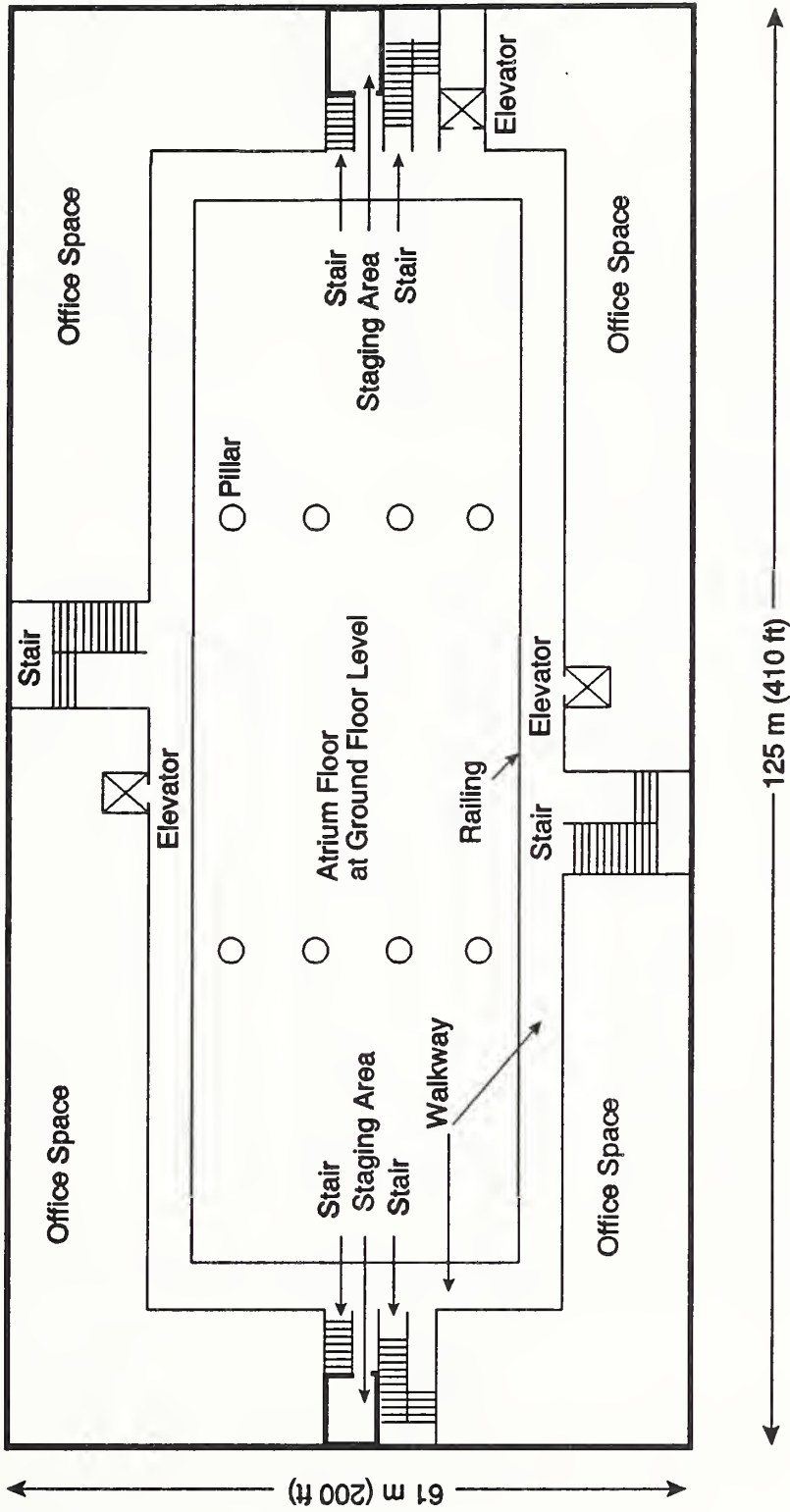

Figure 17. Plan of floor 3 of the Pension Building

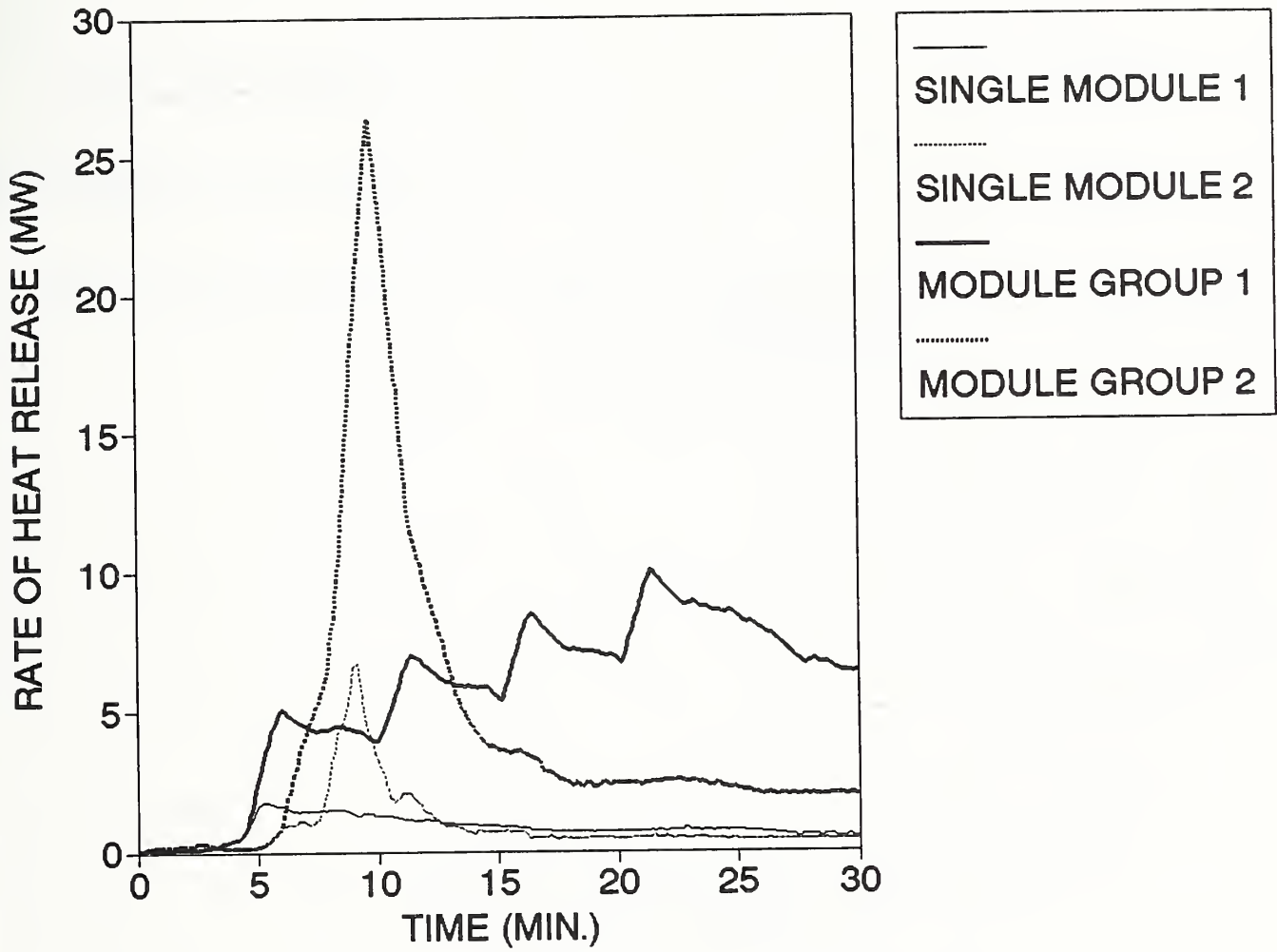

Figure 19. Rate of heat release curves of fires for office buildings

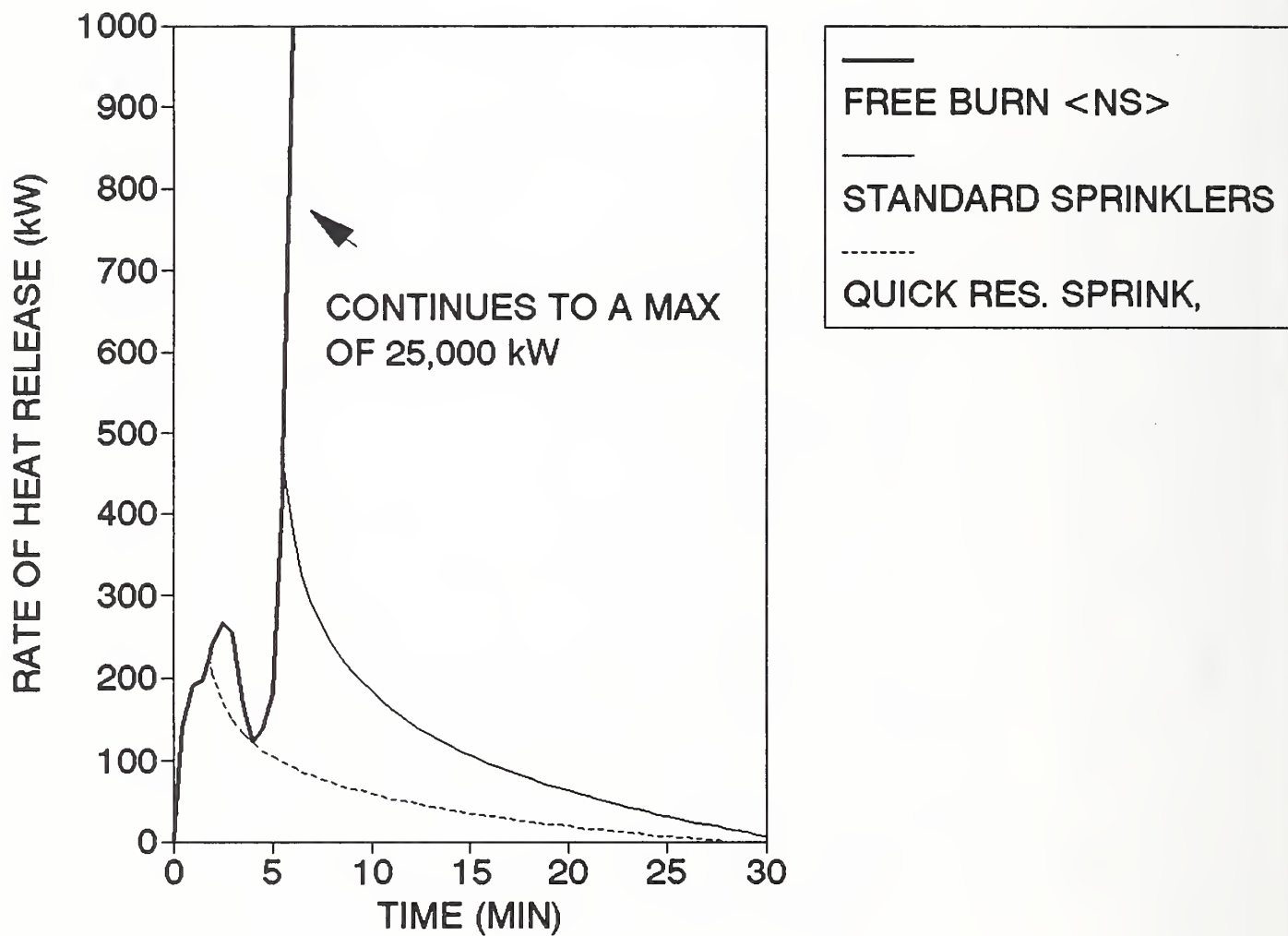

Figure 20. Rate of heat release curves from Module Group 2 fire

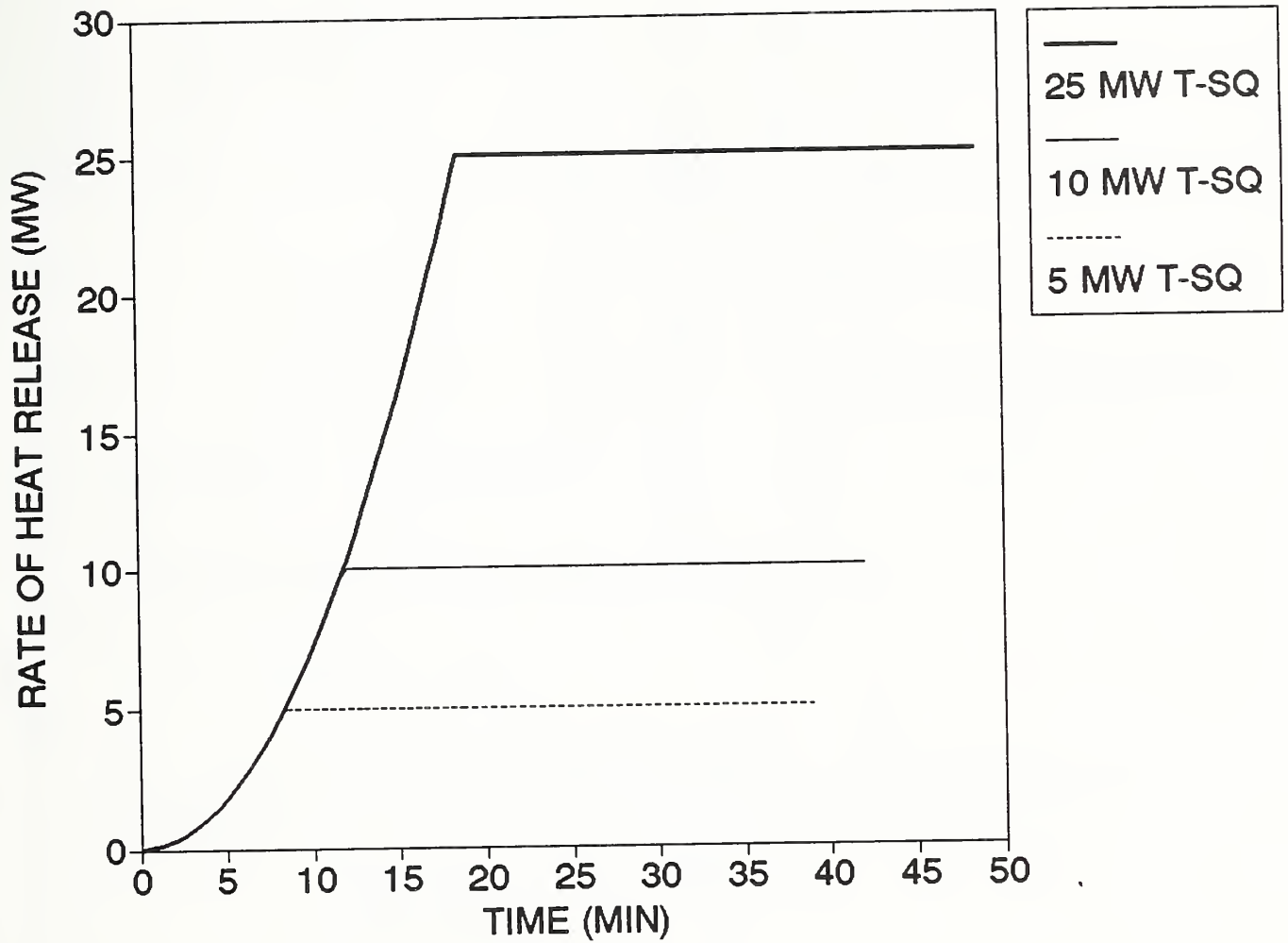

Figure 21. Rate of heat release curves used in atrium of Pension Building

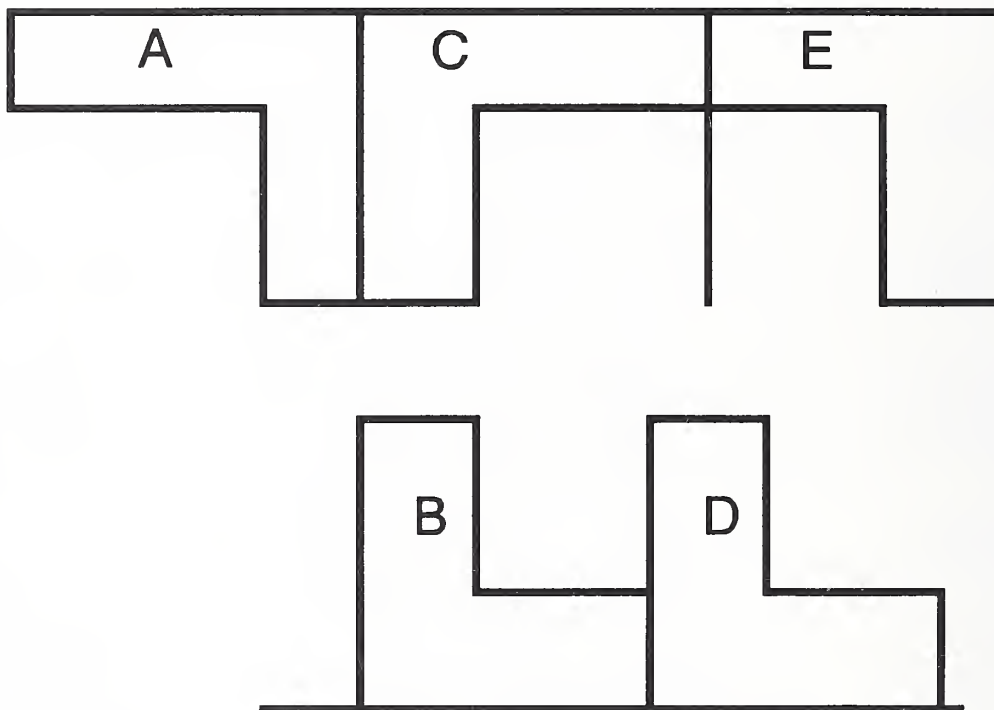

Figure 22. Layout used in FREEBURN calculations.

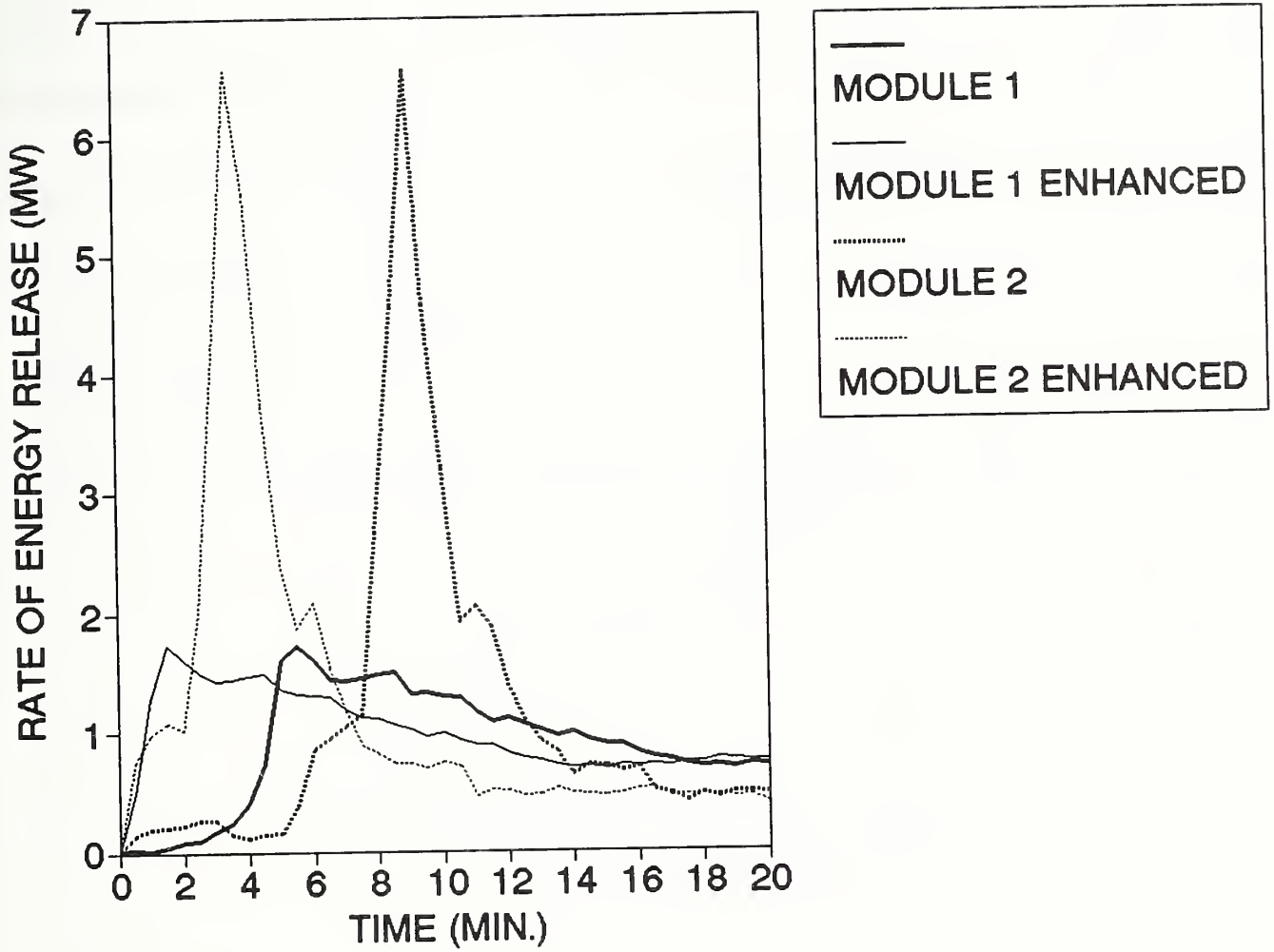

Figure 23. Actual and adjusted fire curves used in FREEBURN calculations.

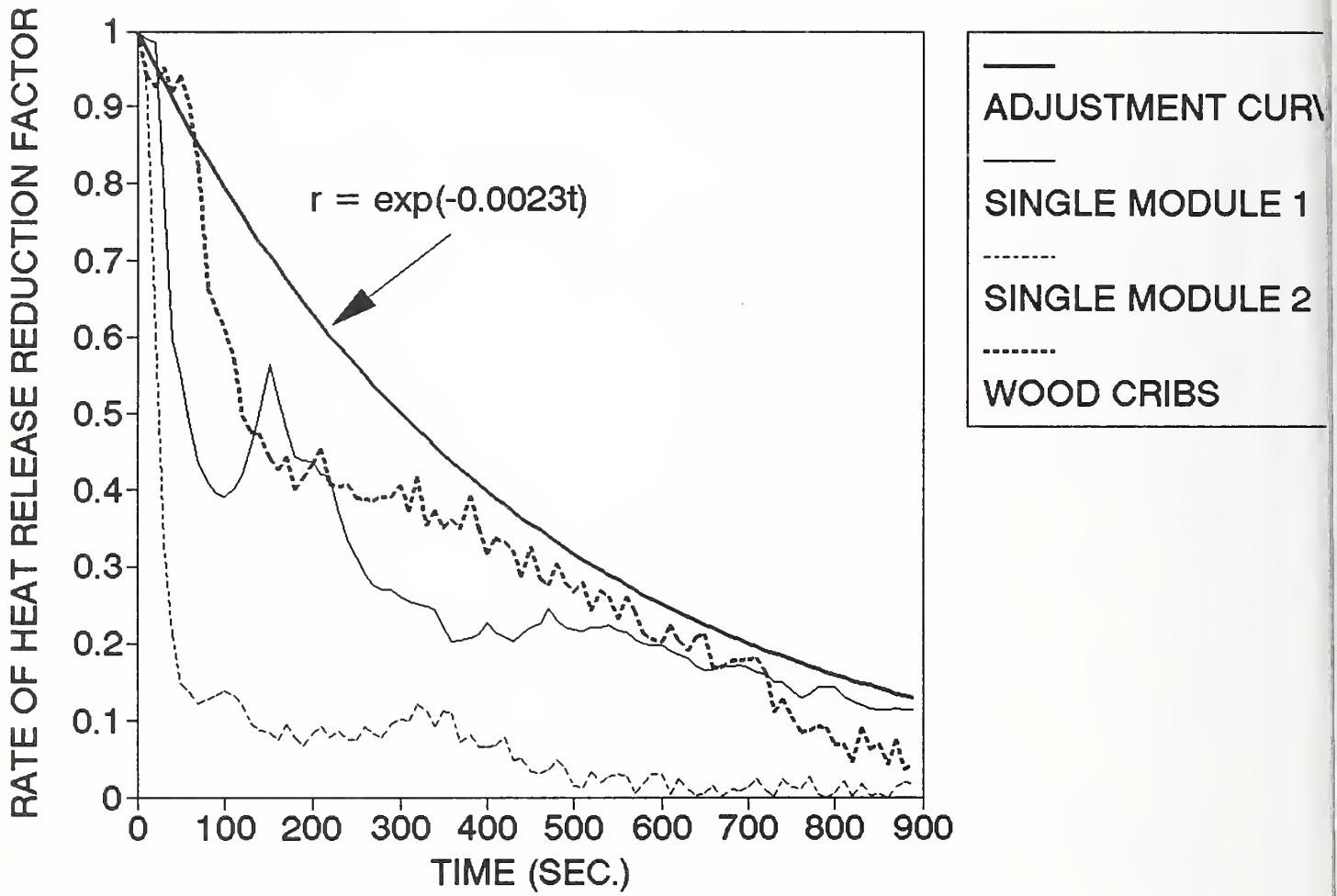

Figure 24. Sprinkler impact adjustment curve.

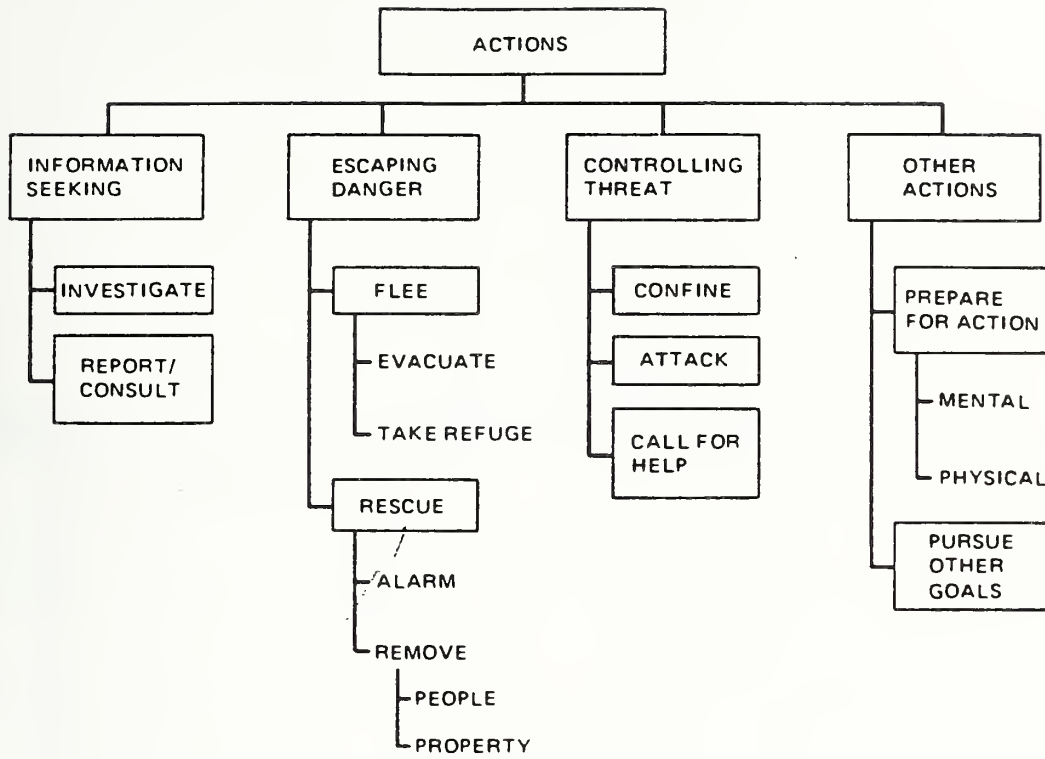

Figure 25. Types of emergency actions following alarm.

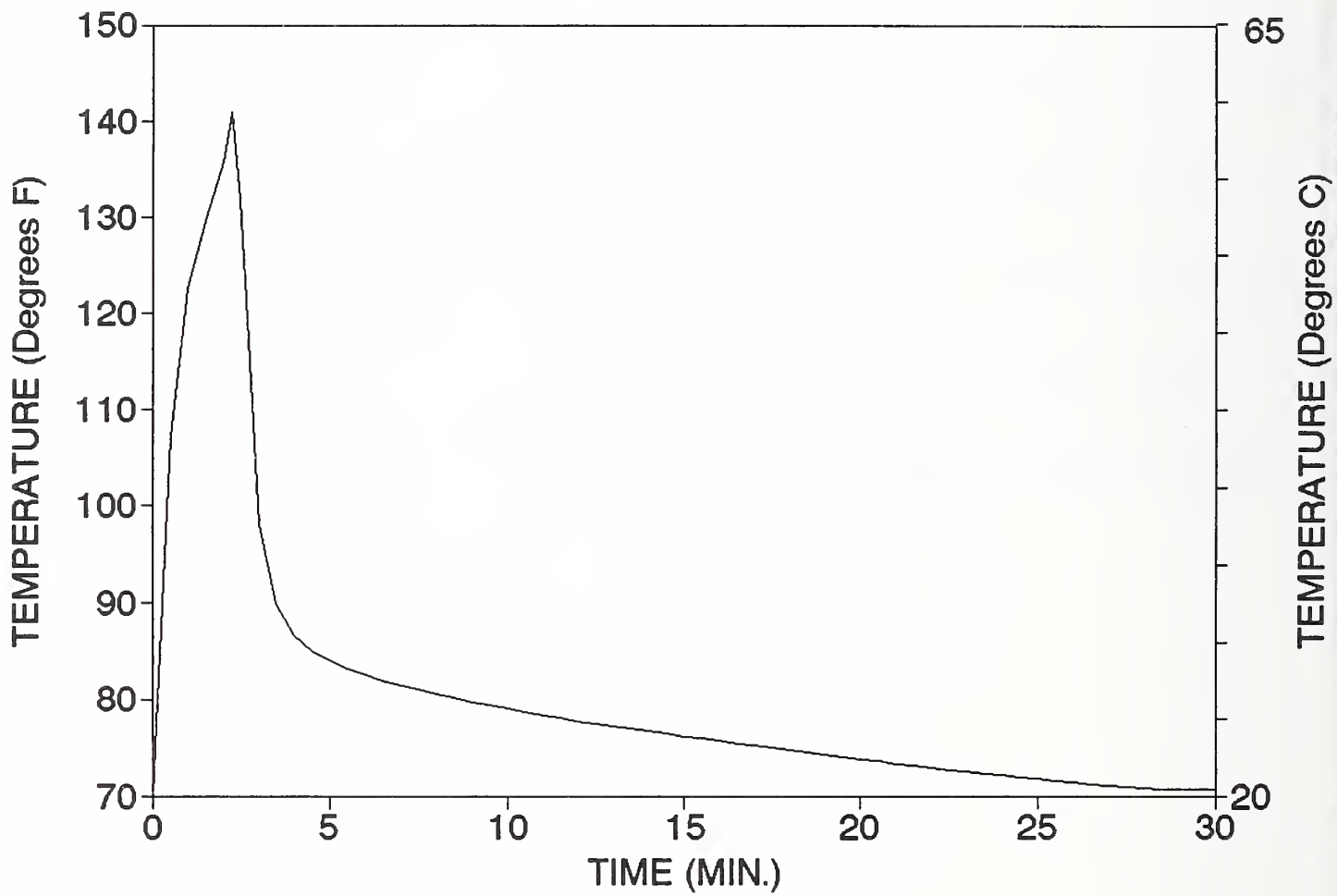

Figure 26. Smoke temperature in open plan space in VA Building.

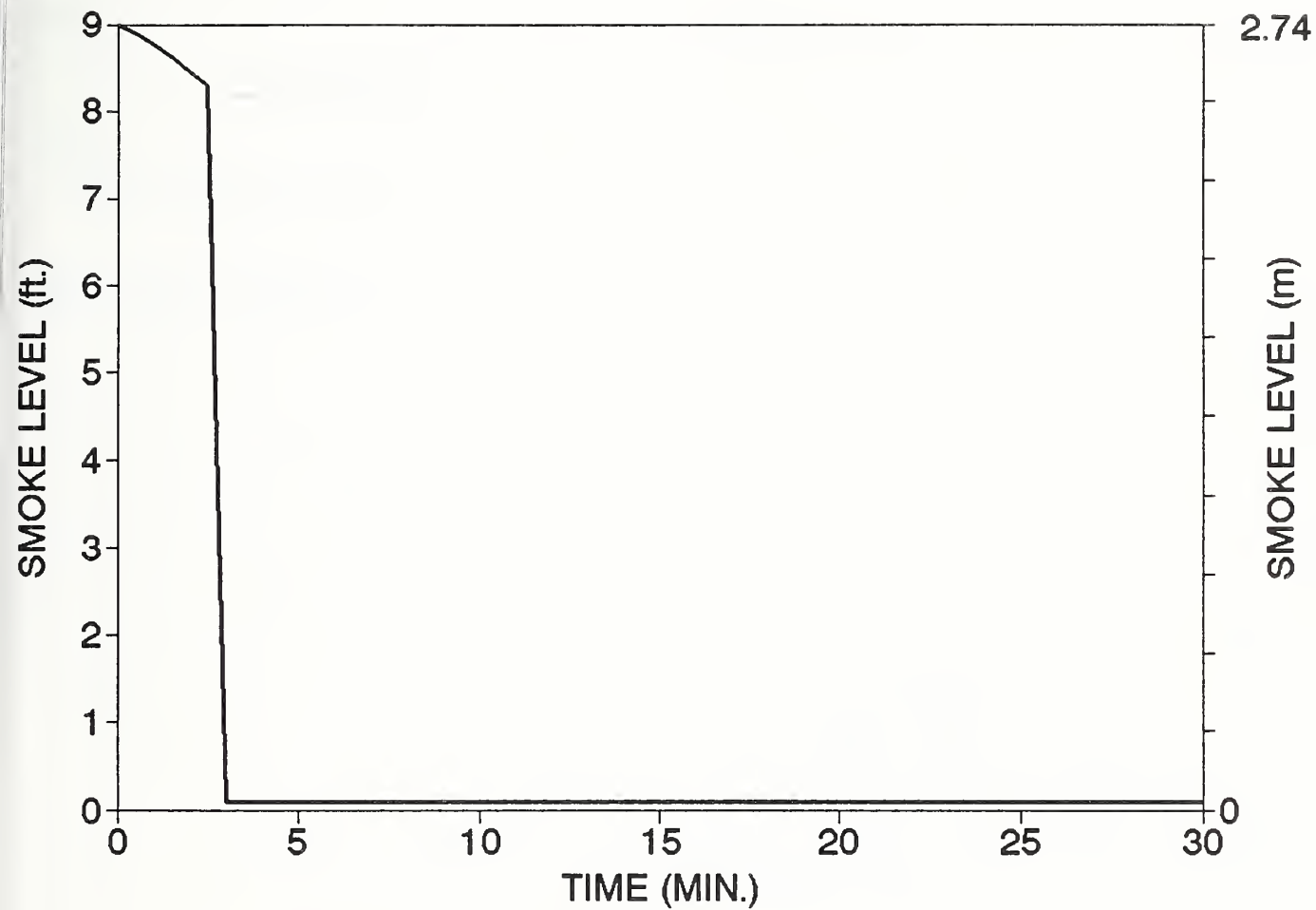

Figure 27. Smoke level in open plan space in VA Building.

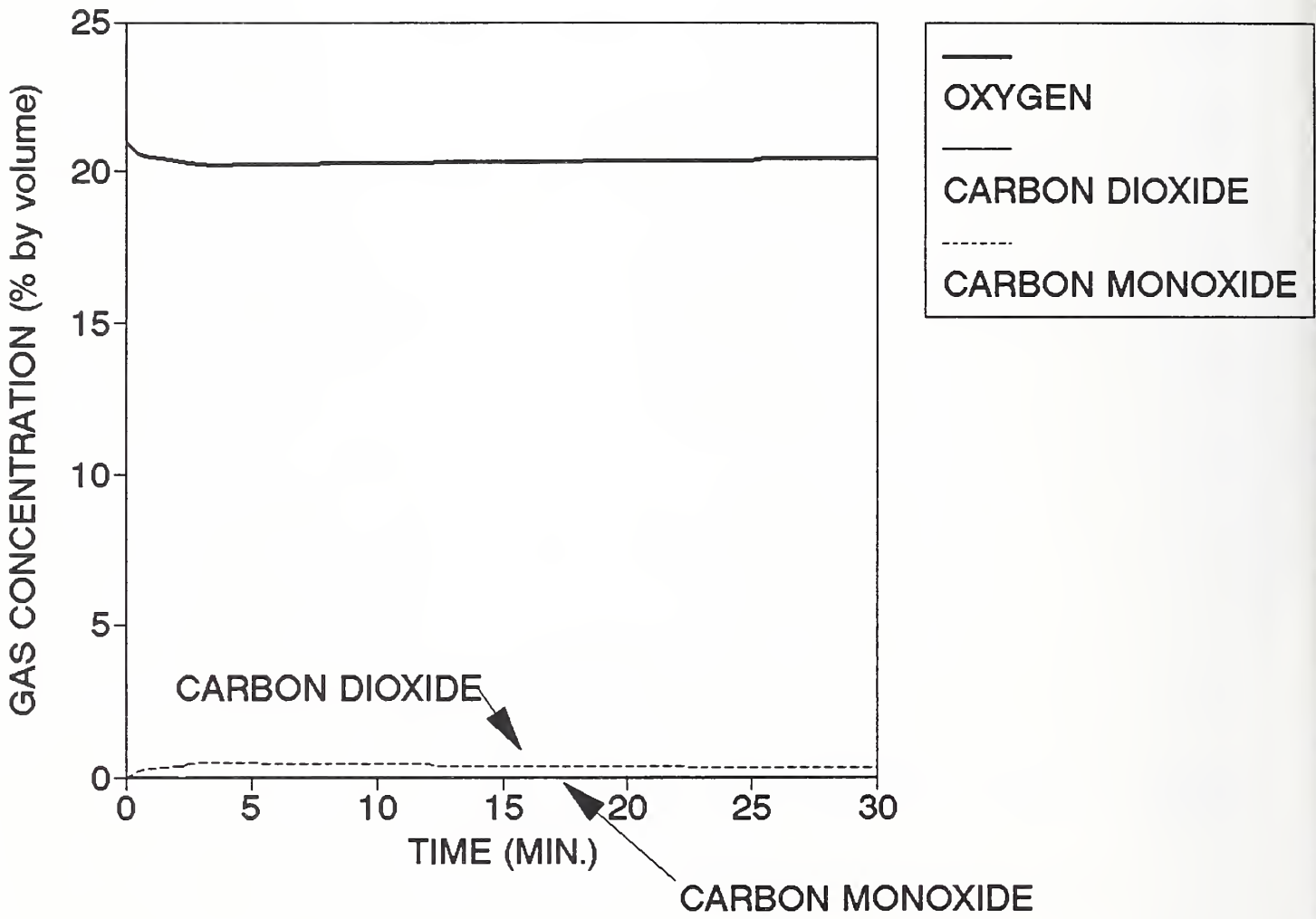

Figure 28. Gas concentrations in open plan space in VA Buildings.

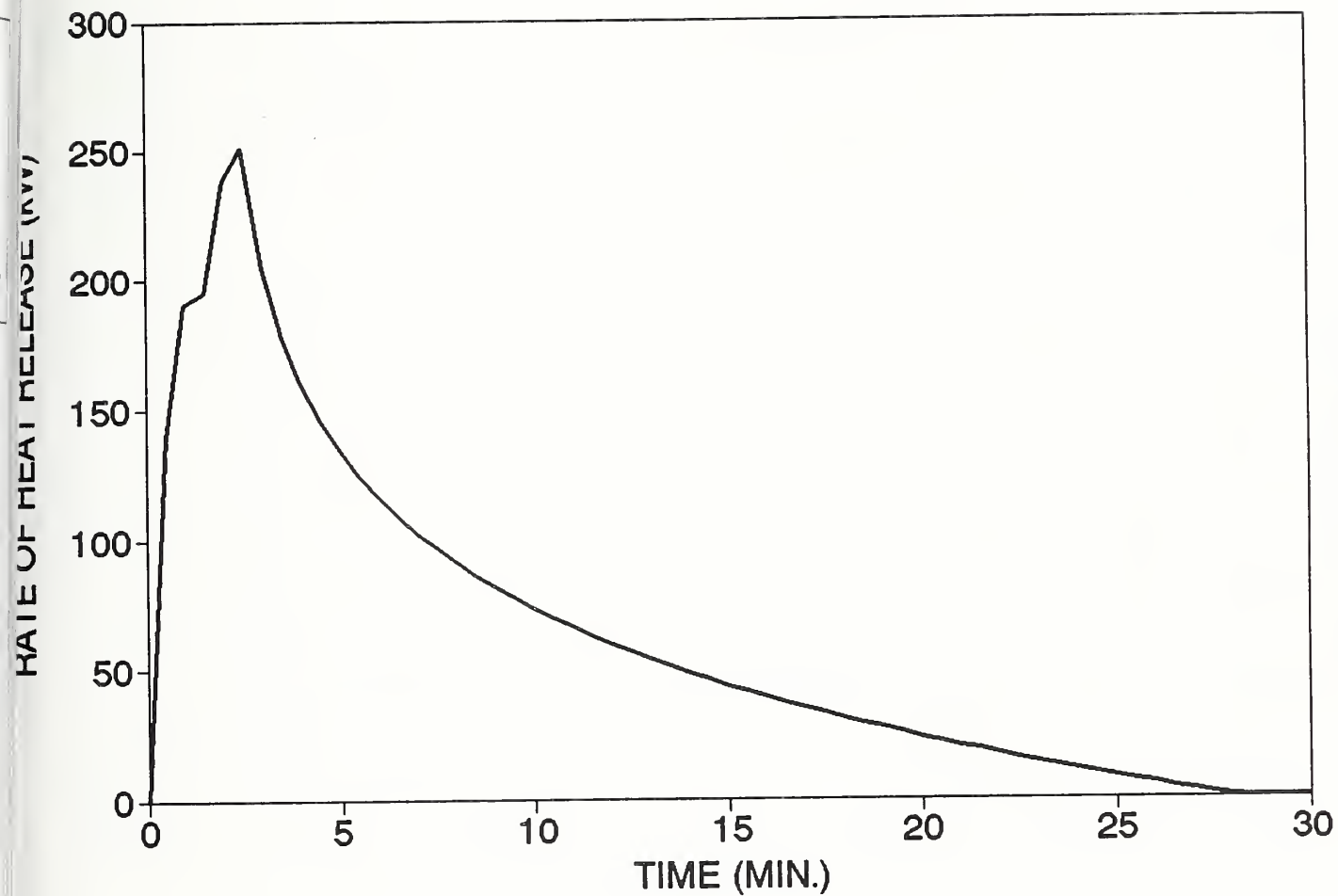

Figure 29. Rate of heat release curve used in open plan spaces in VA Building.

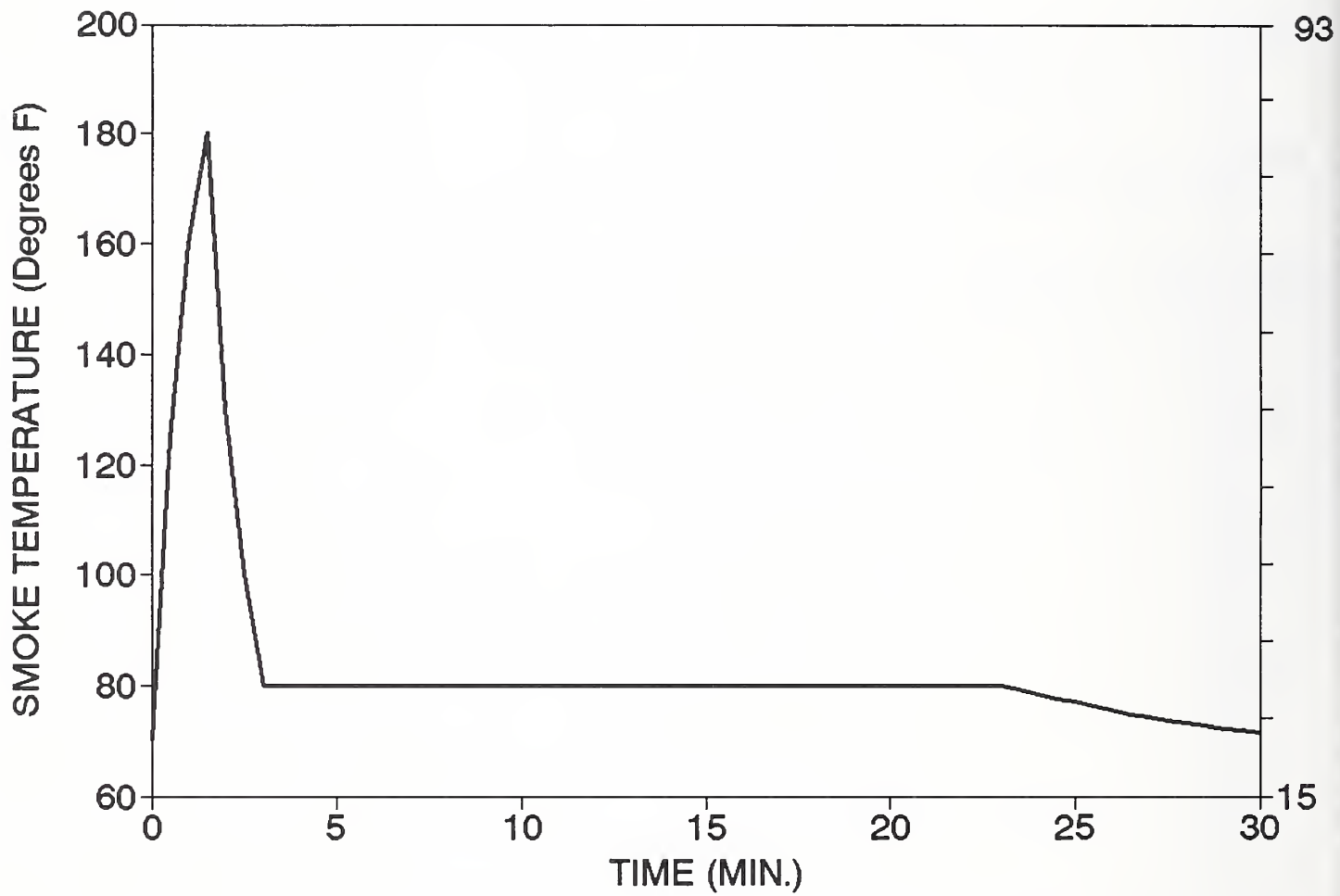

Figure 30. Smoke temperature in individual room in VA Building.

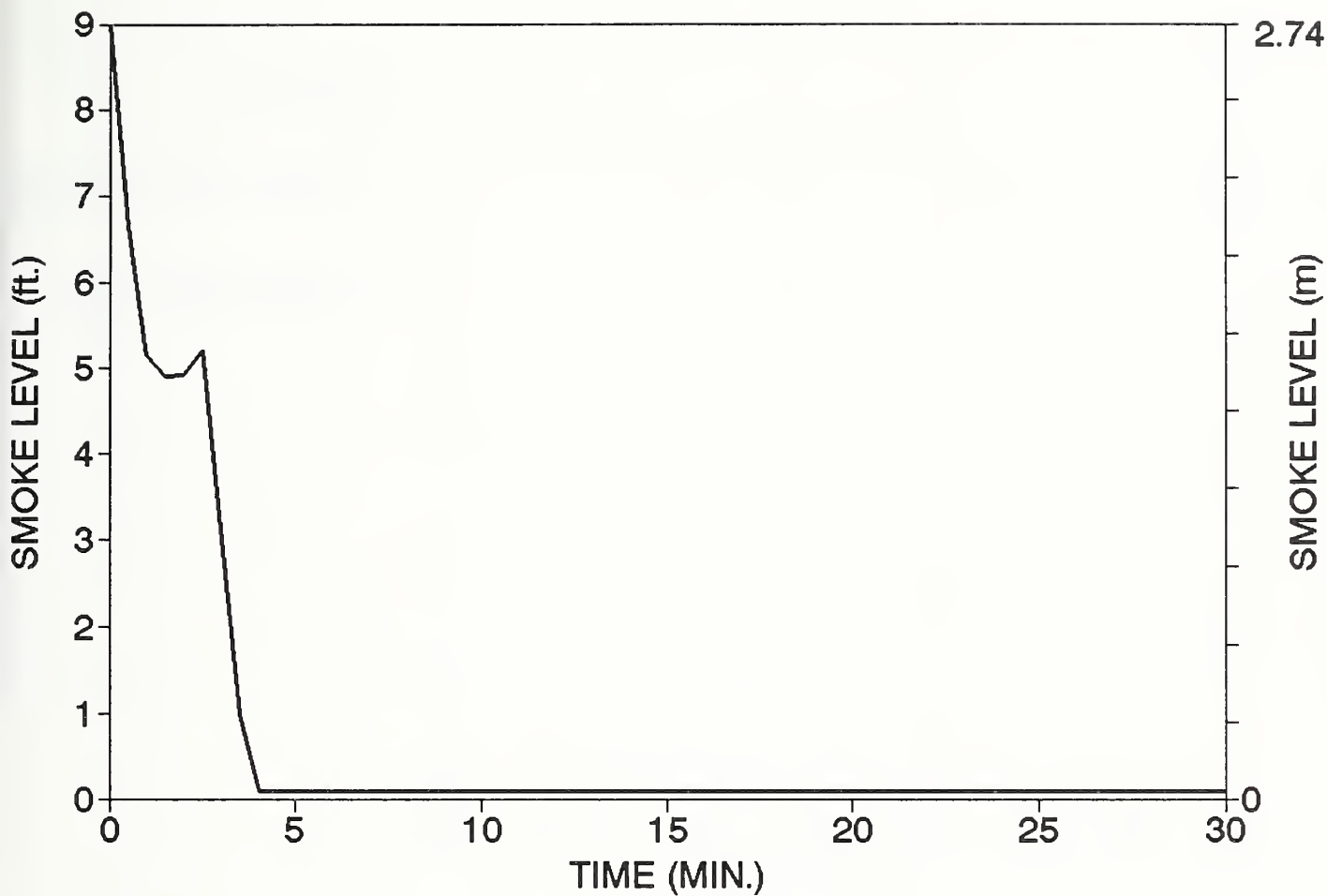

Figure 31. Smoke level in individual room in VA Building.

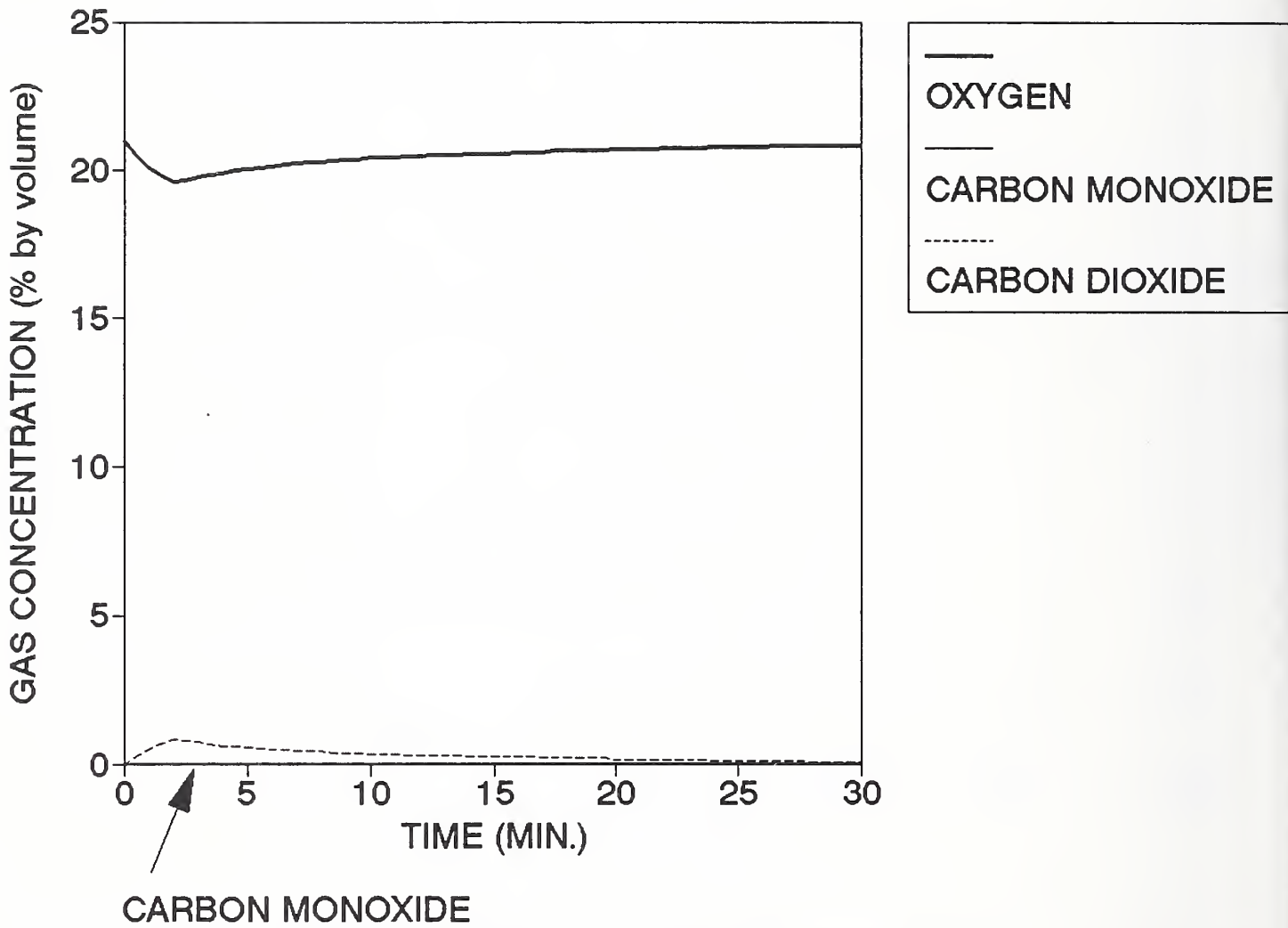

Figure 32. Gas in smoke in individual room in VA Building.

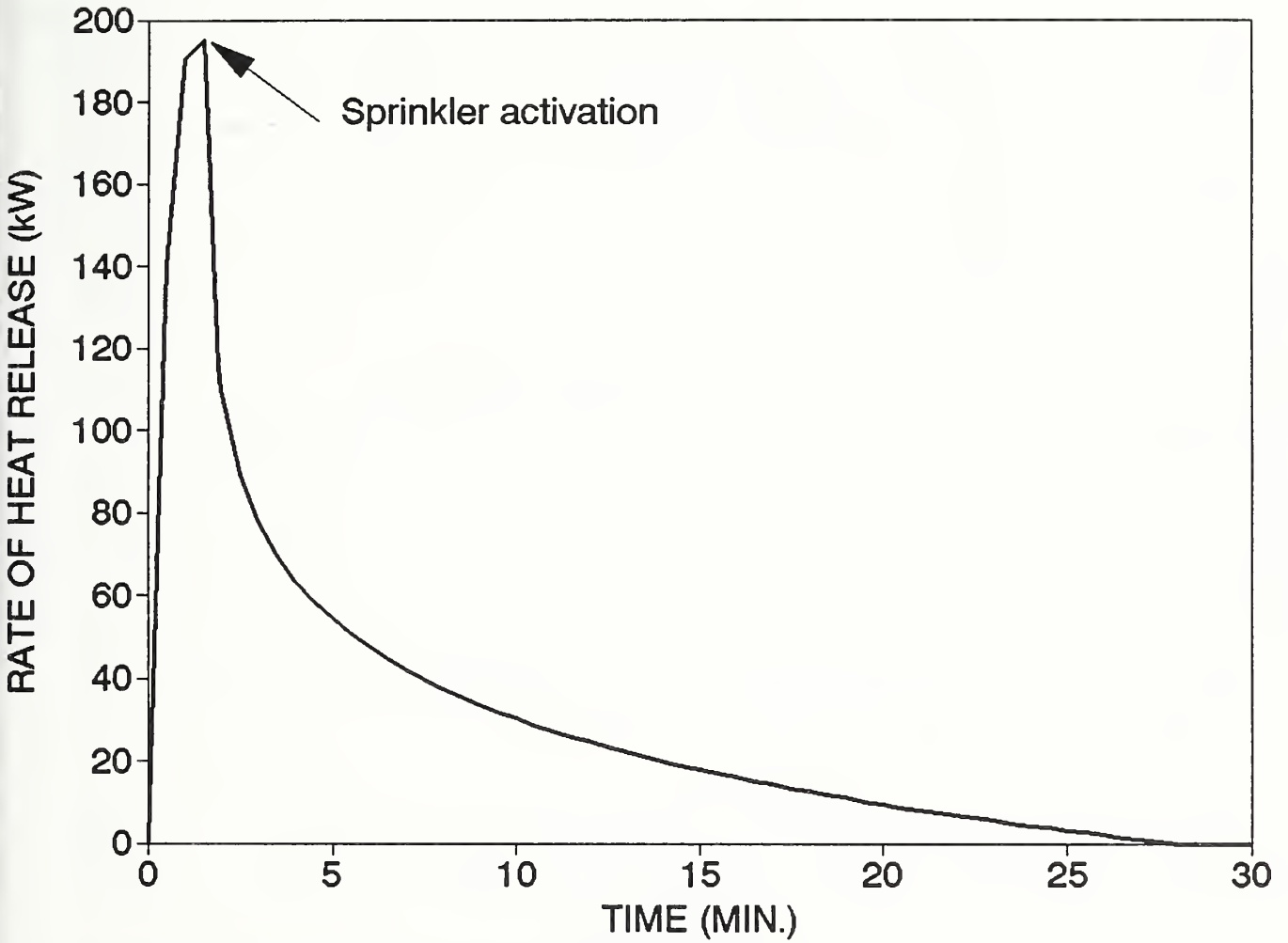

Figure 33. Rate of heat release used in individual room calculations in VA Bldg.

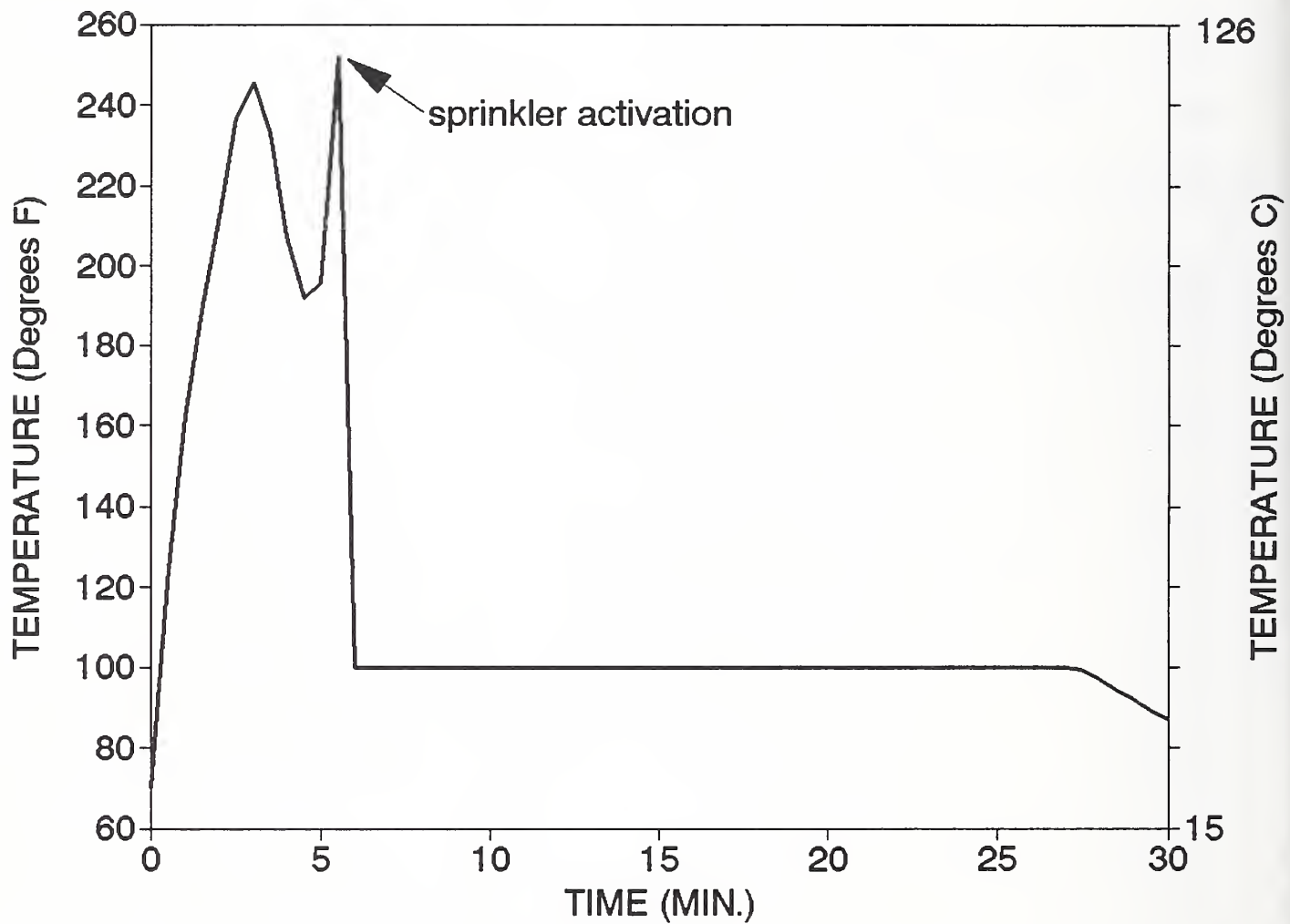

Figure 34. Smoke temperature in an individual room in Whipple Building.

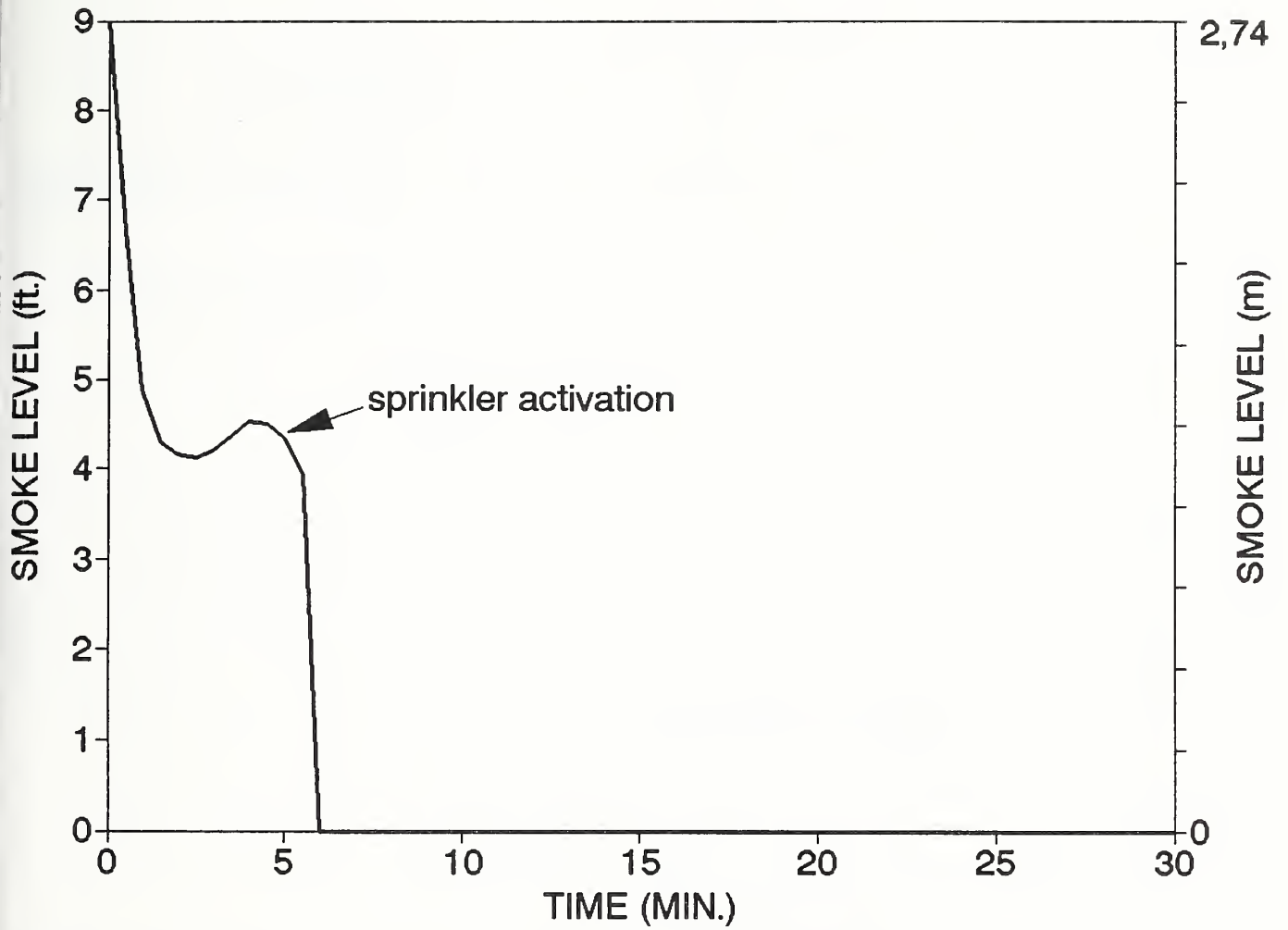

Figure 35. Smoke level in an individual room in Whipple Building

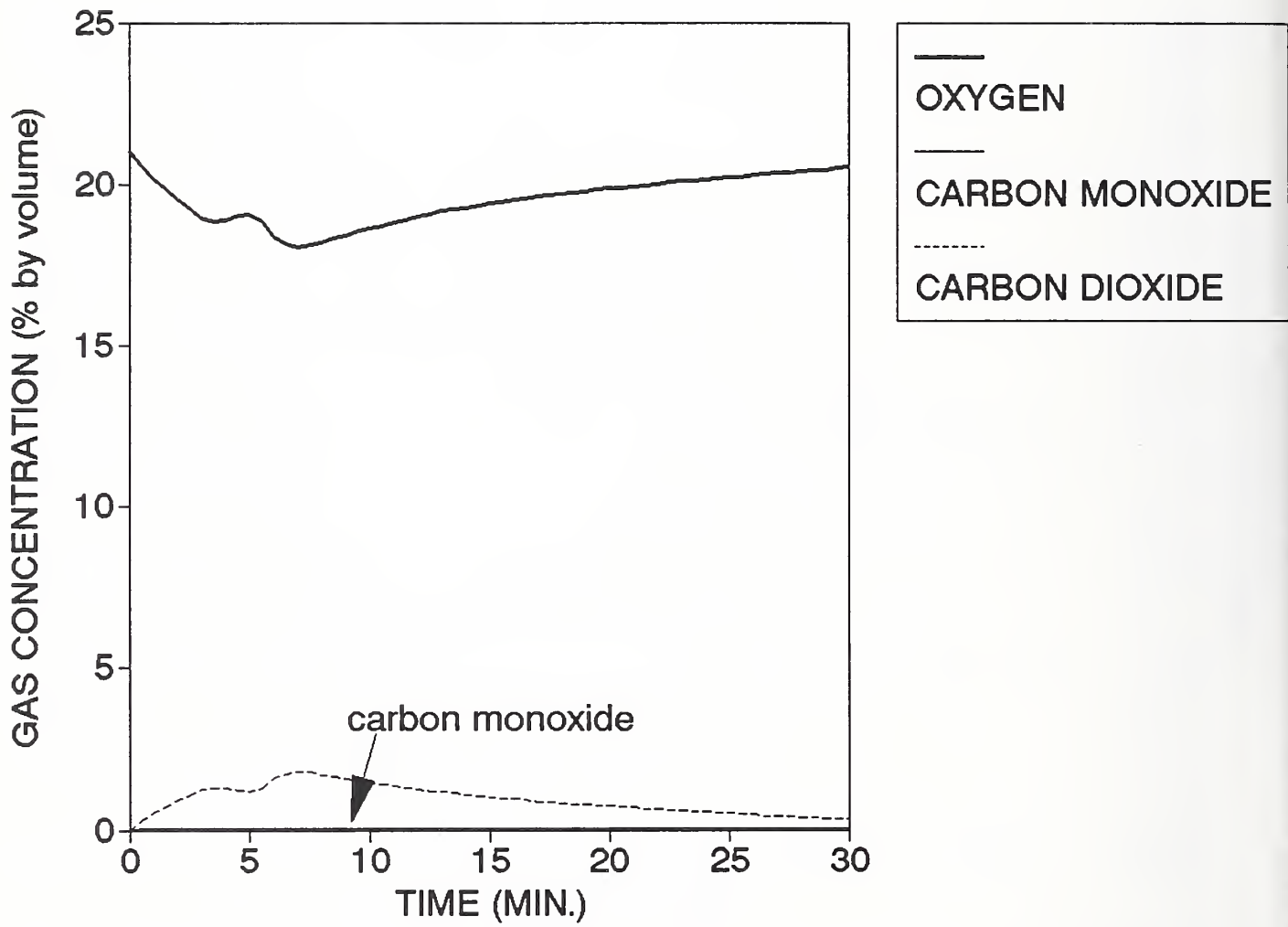

Figure 36. Gas concentrations in smoke in individual room in Whipple Building

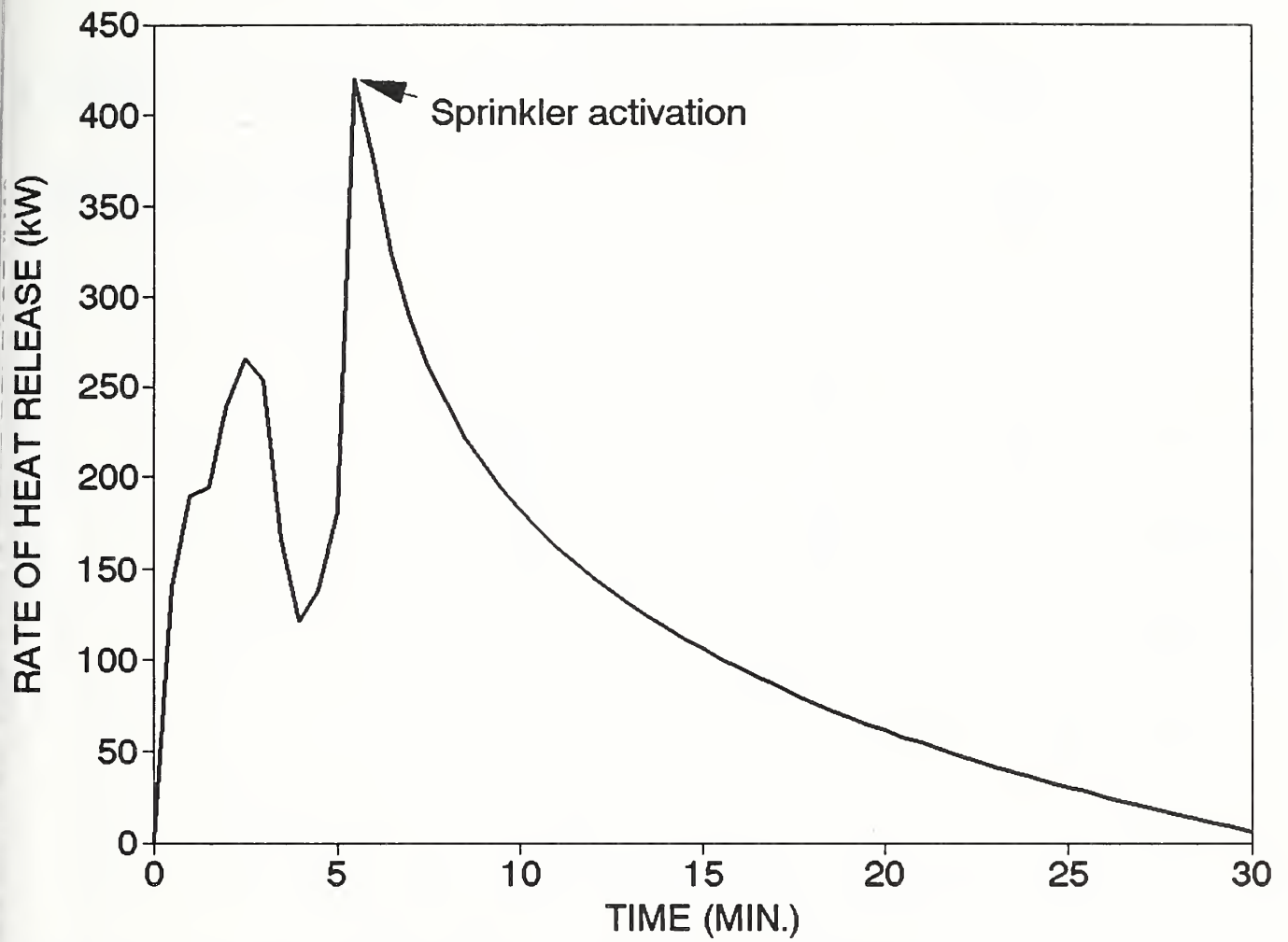

Figure 37. Rate of heat release used in Whipple Building

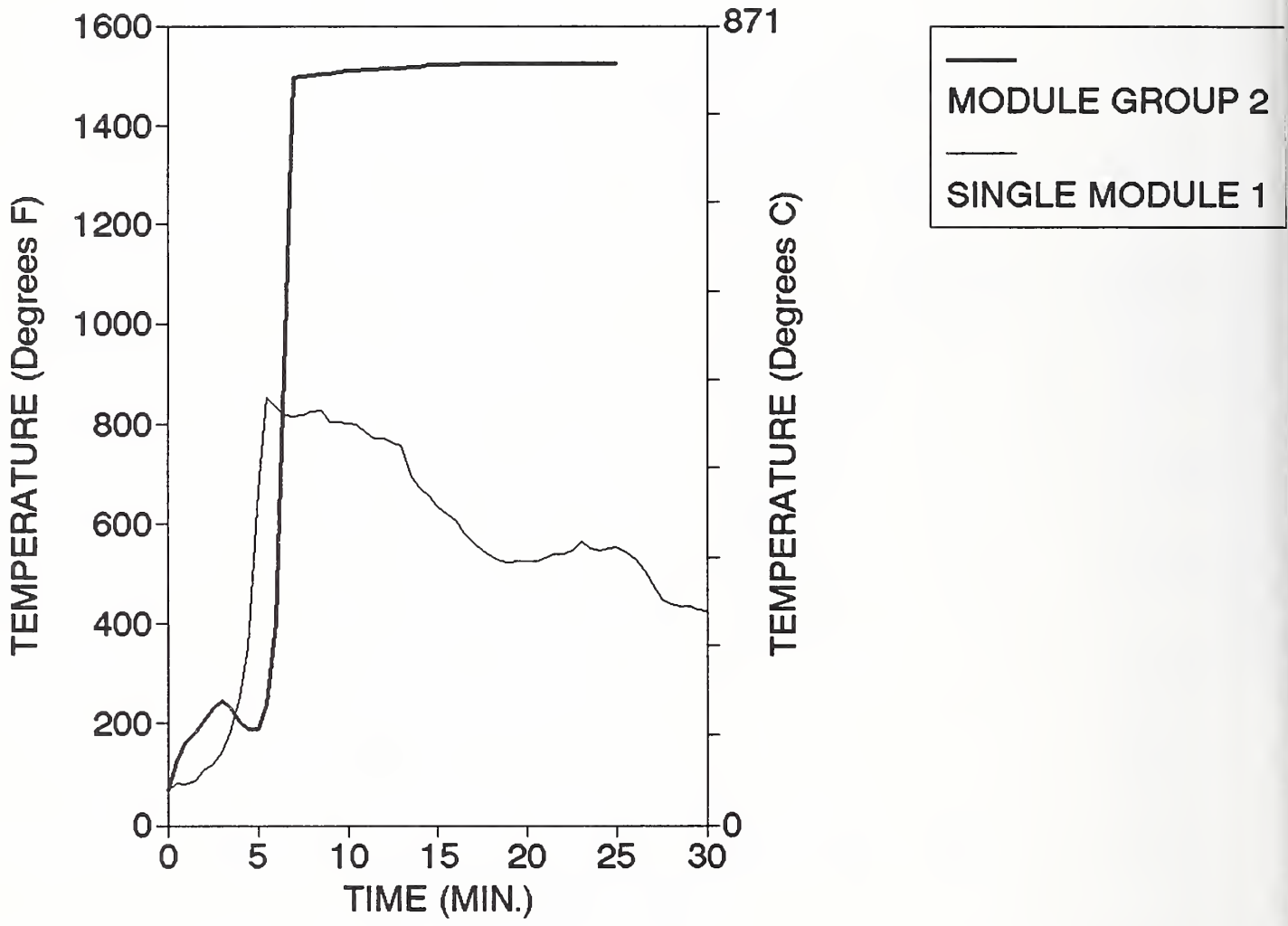

Figure 38. Smoke temperature in an individual room in Bemidji building.

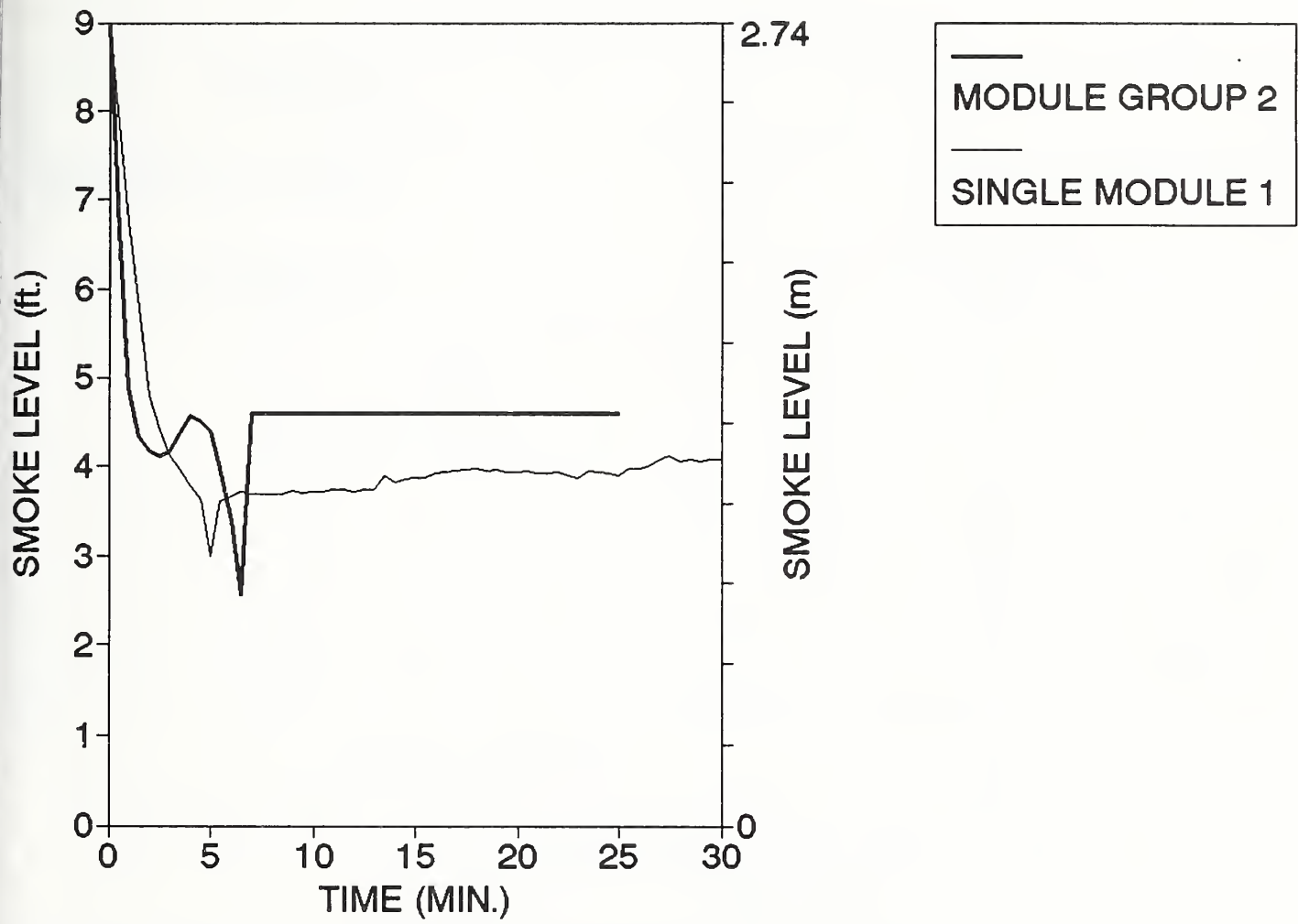

Figure 39.. Smoke level in an individual room in Bemidji building.

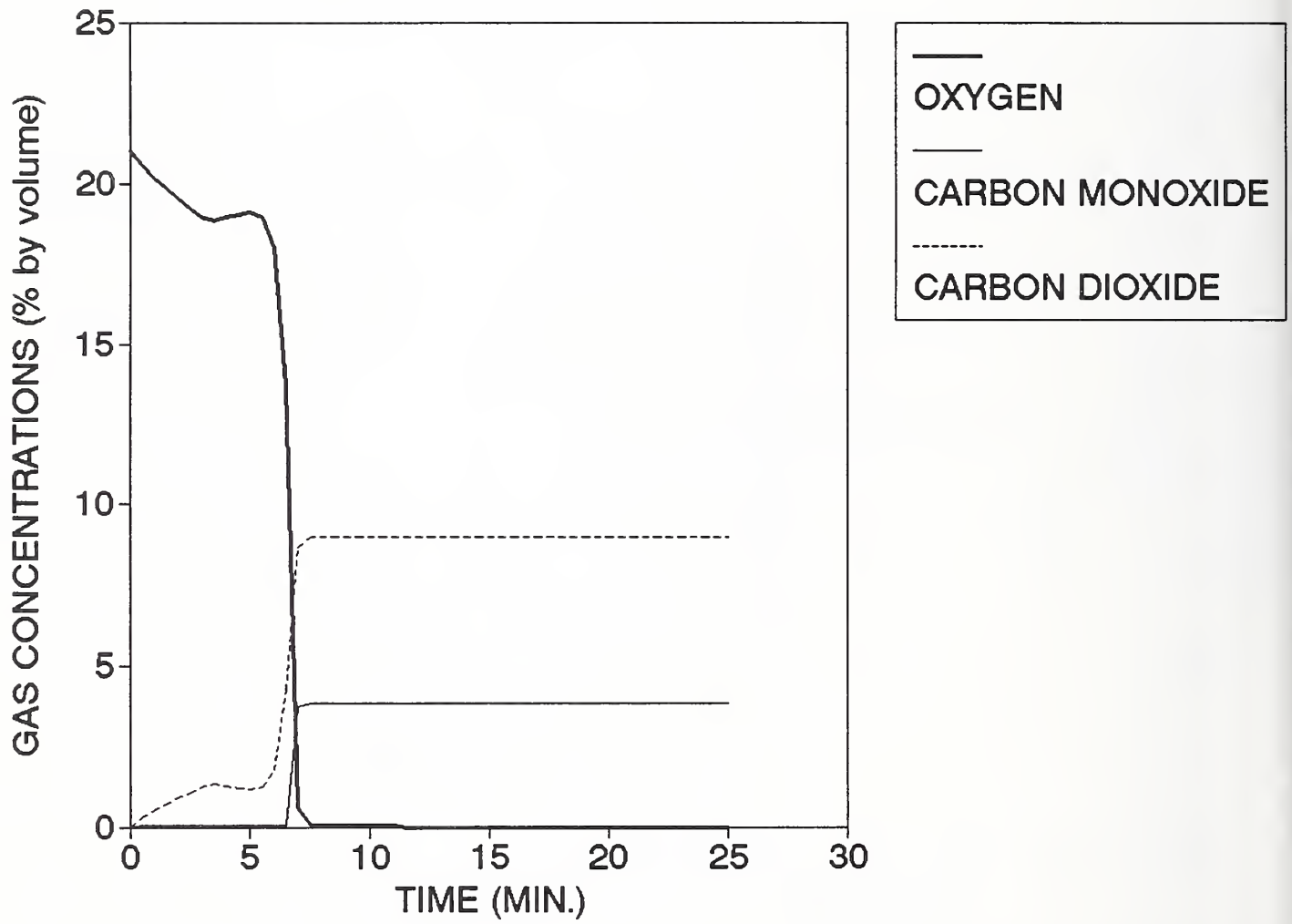

Figure 40 Gases from Module 2 fire in individual room in Bemidji building.

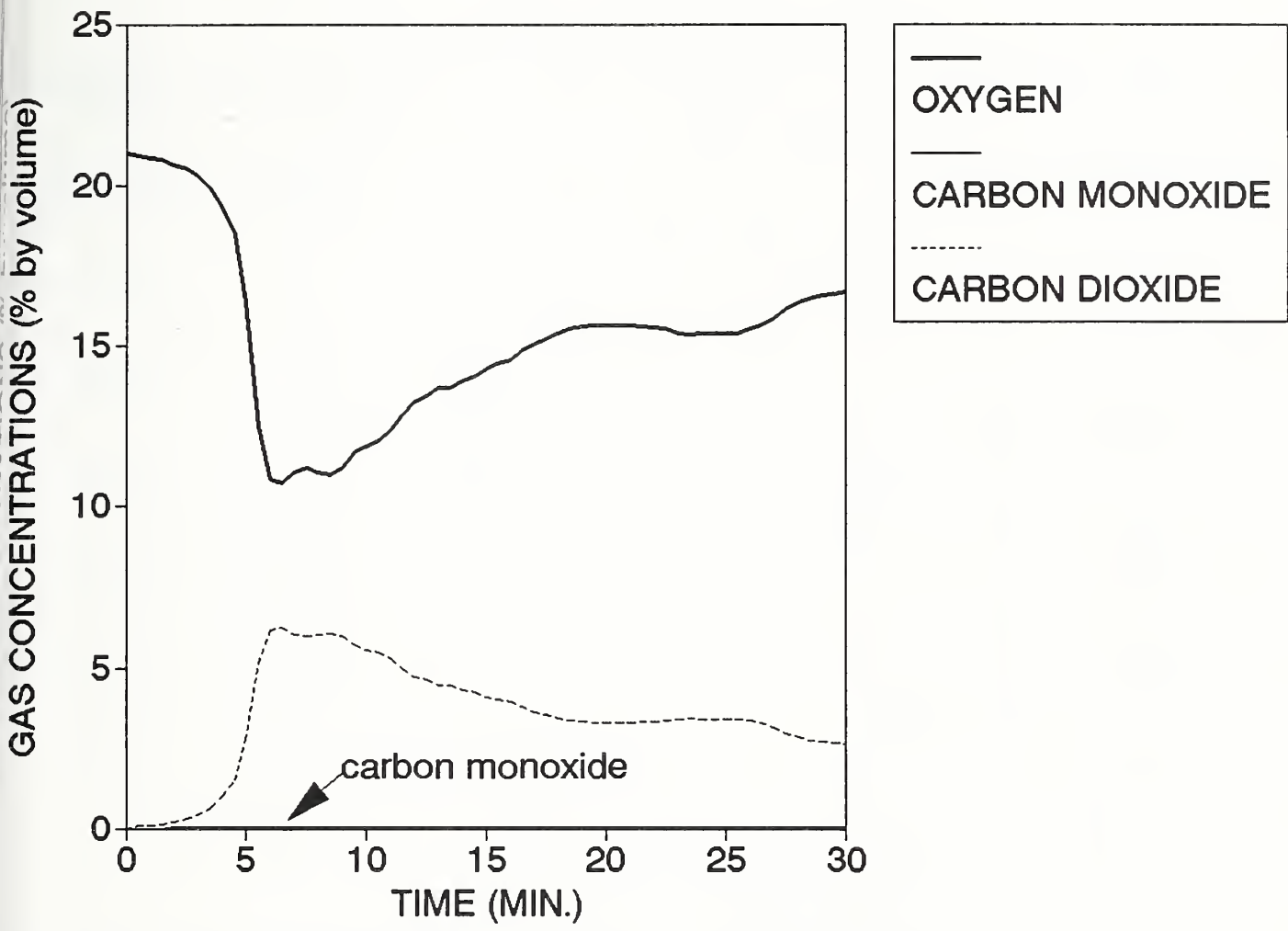

Figure 41. Gases from Single Module 1 fire in individual room in Bemidji building.

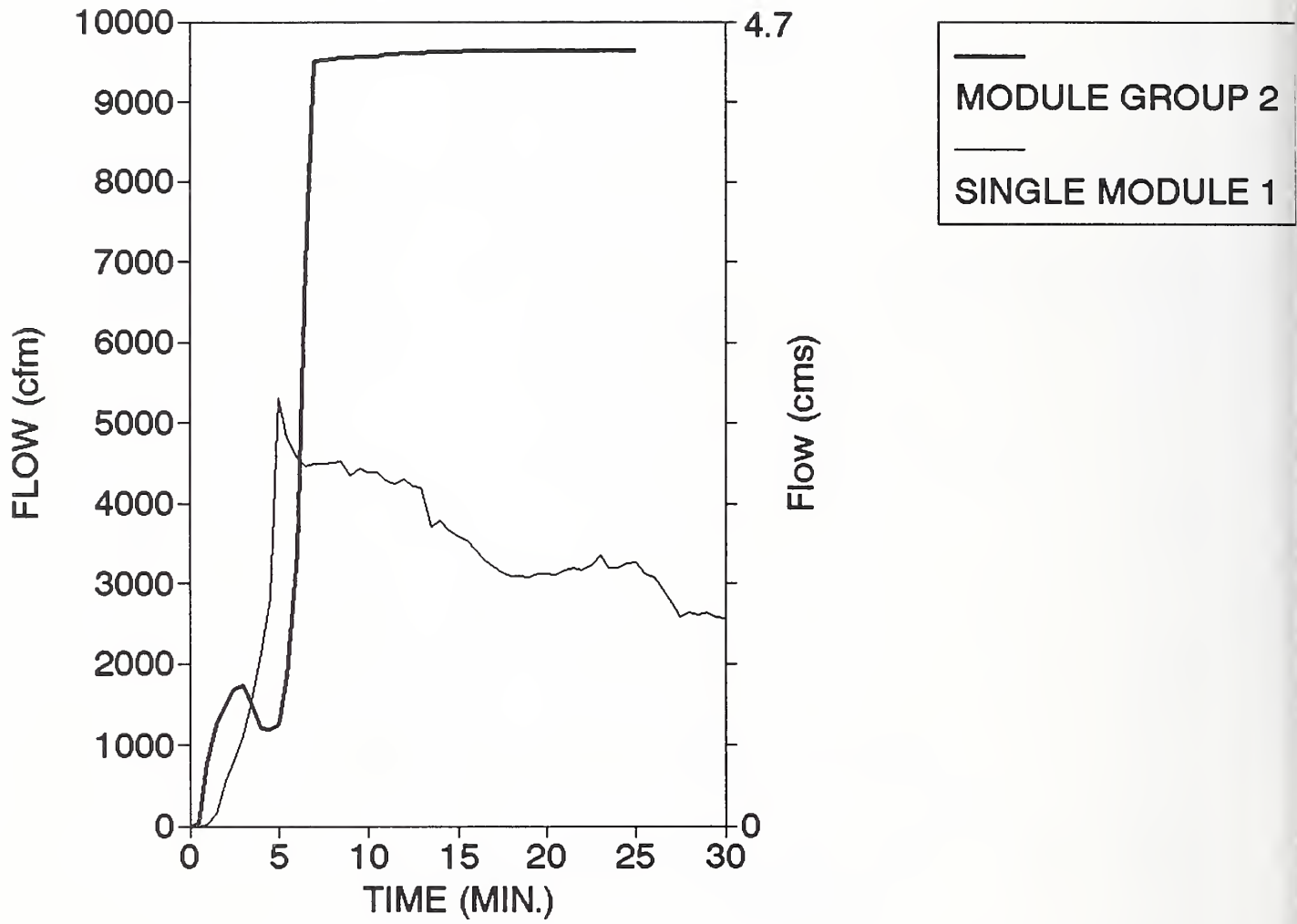

Figure 42. Smoke flow from individual room in Bemidji building into corridor.

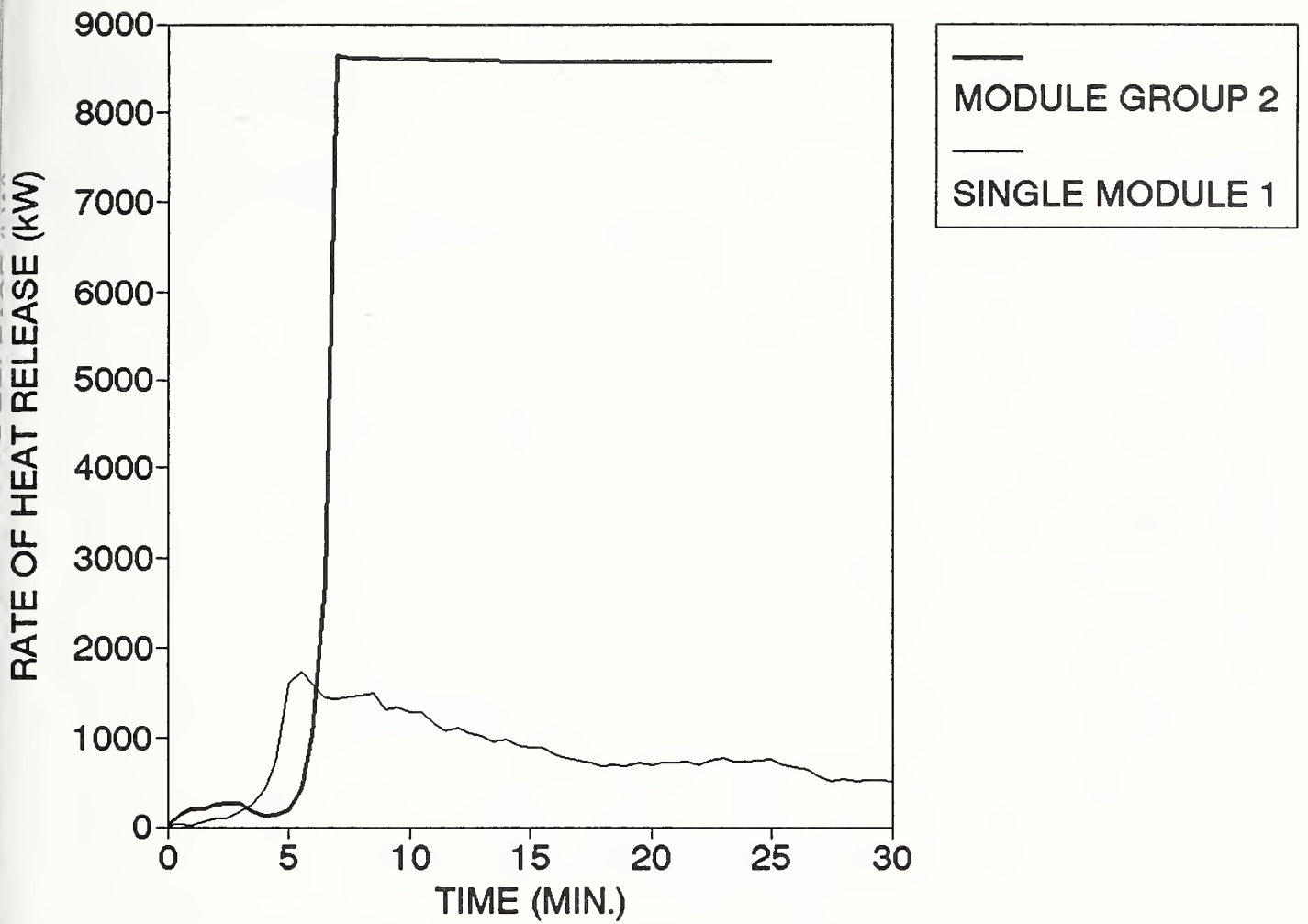

Figure 43. Rate of heat release within individual room in Bemidji building.

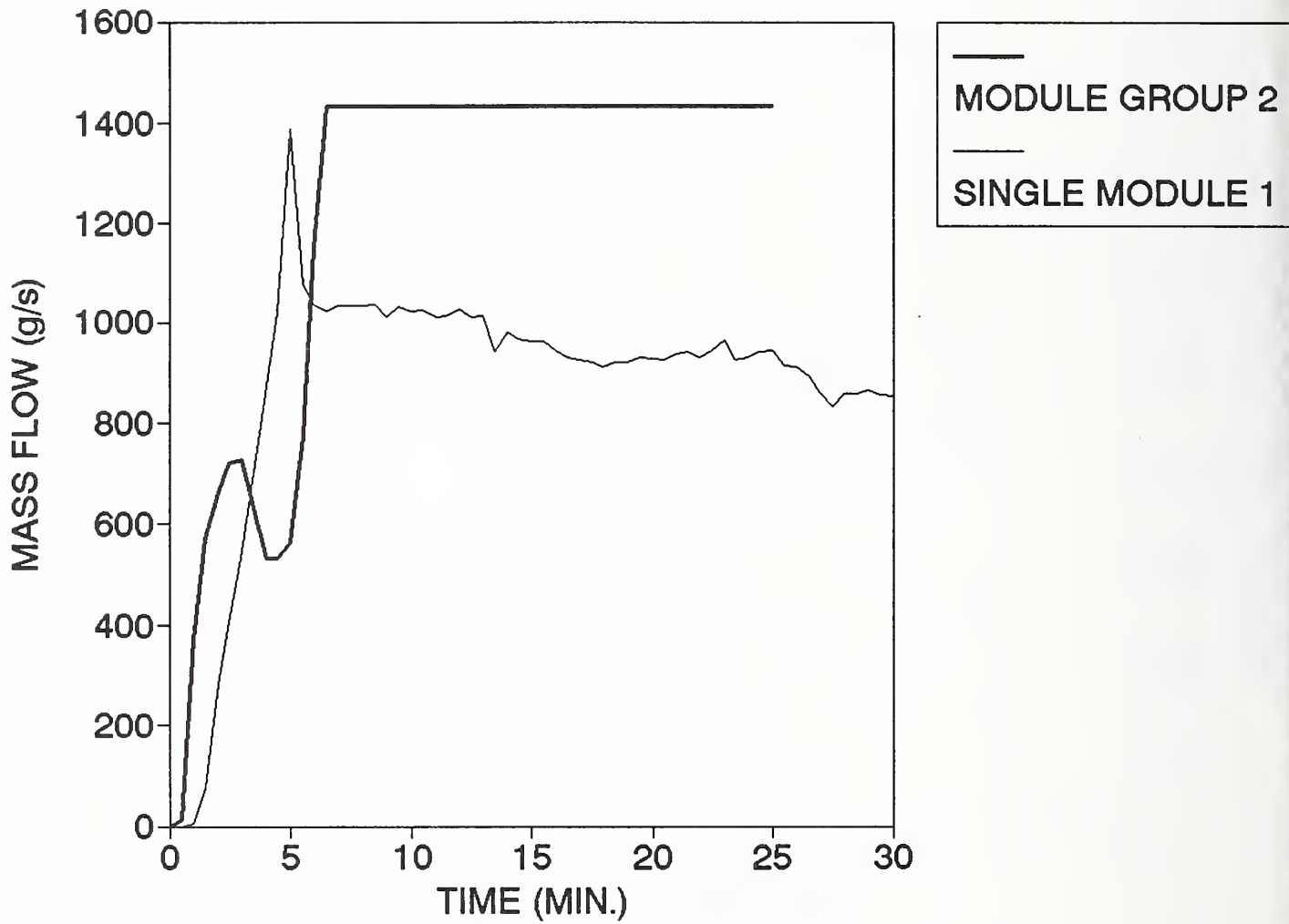

Figure 44. Mass flow from an individual room in Bemidji Building into corridor.

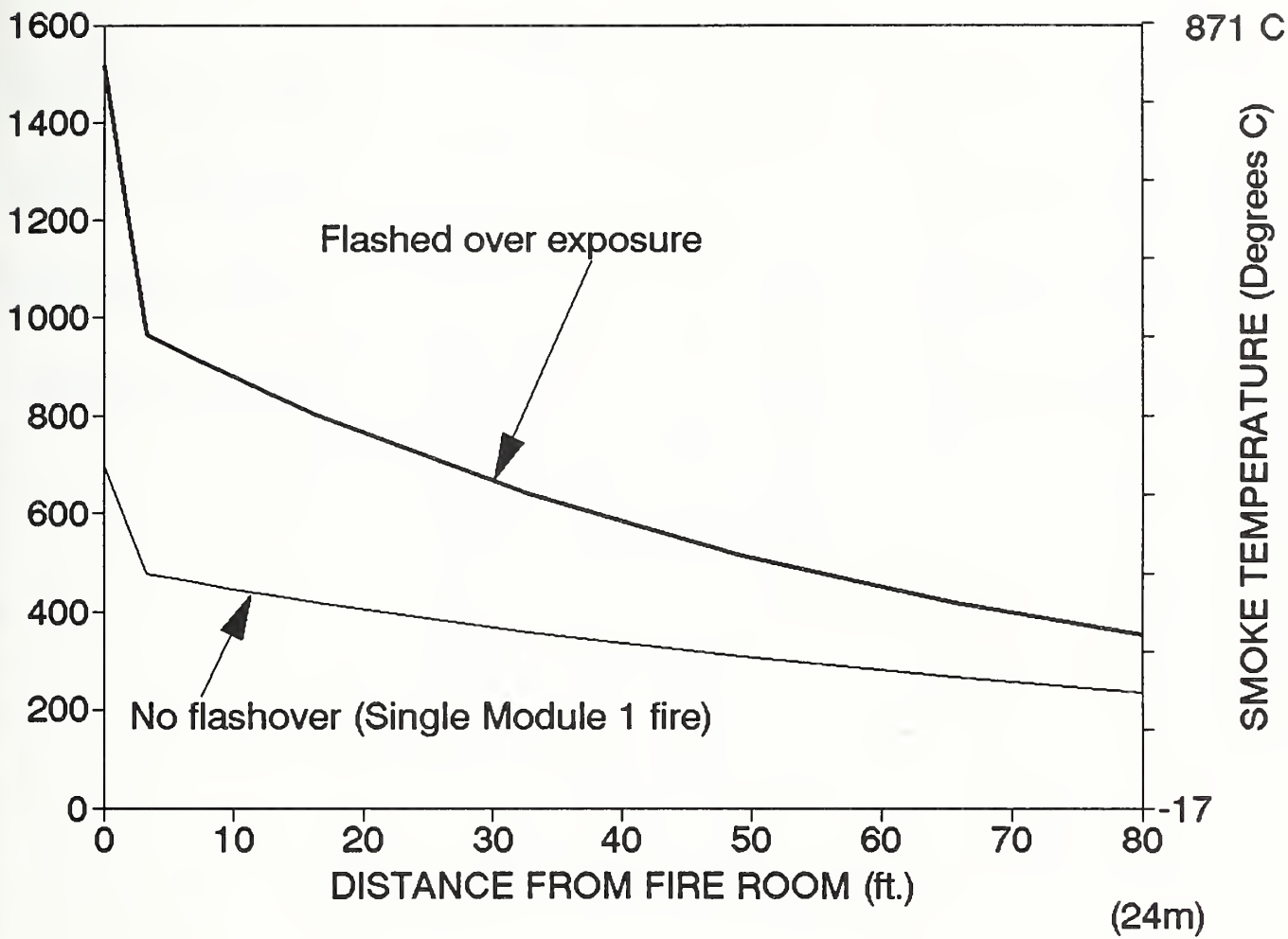

Figure 45. Temperature profiles in corridor of Bemidji building

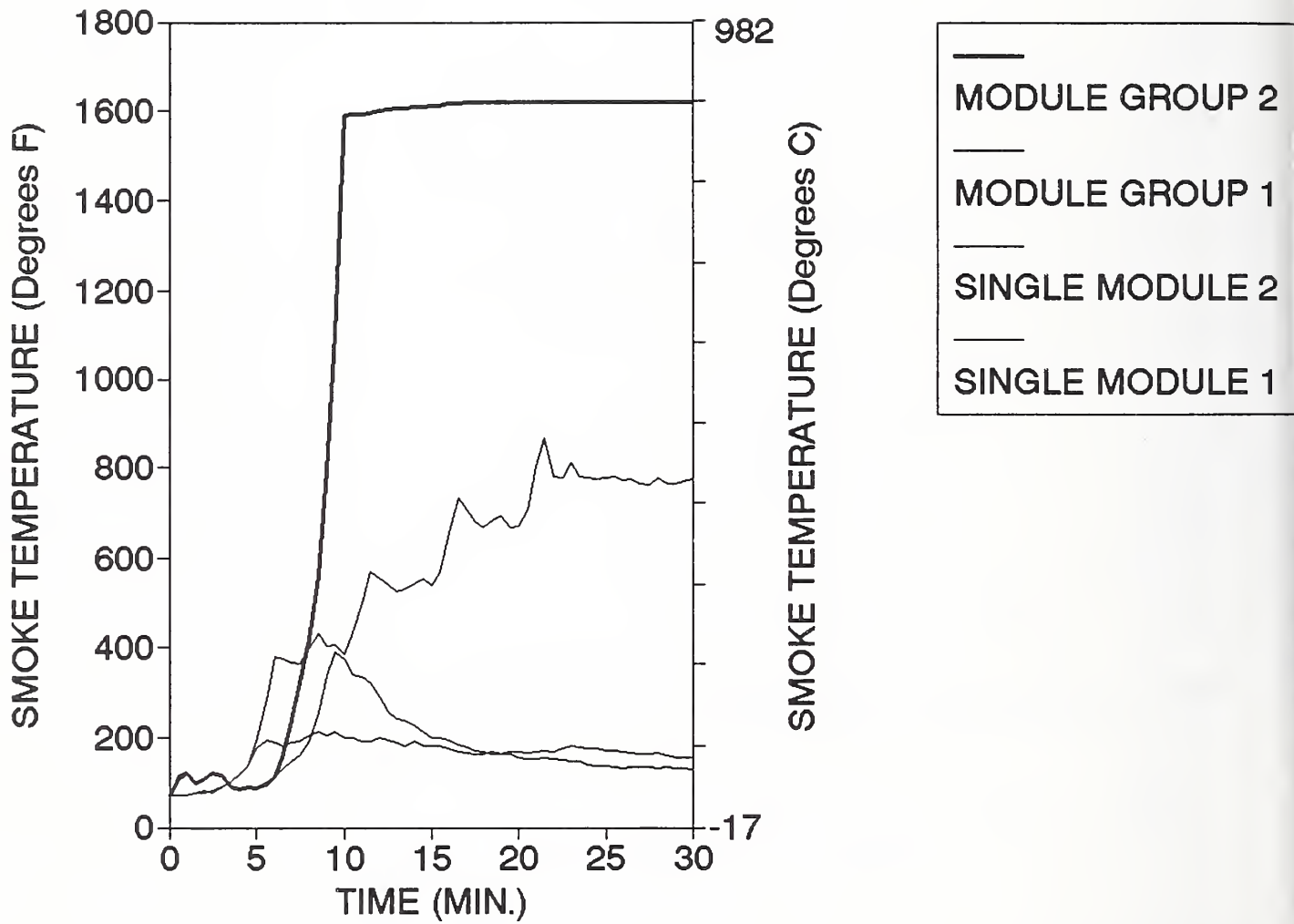

Figure 46. Smoke temperatures in open plan area in Toledo building.

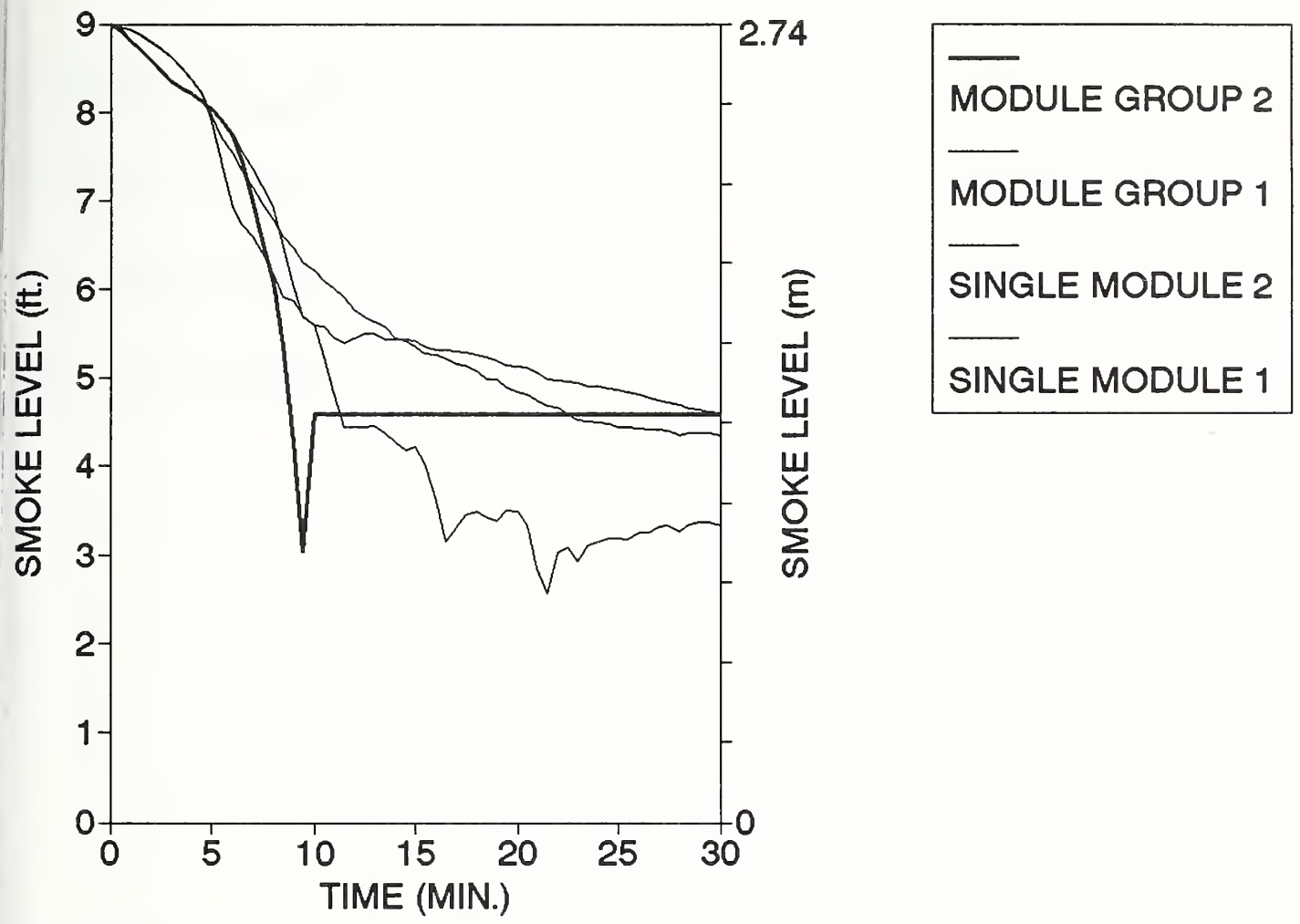

Figure 47. Smoke level in open plan space in Toledo building.

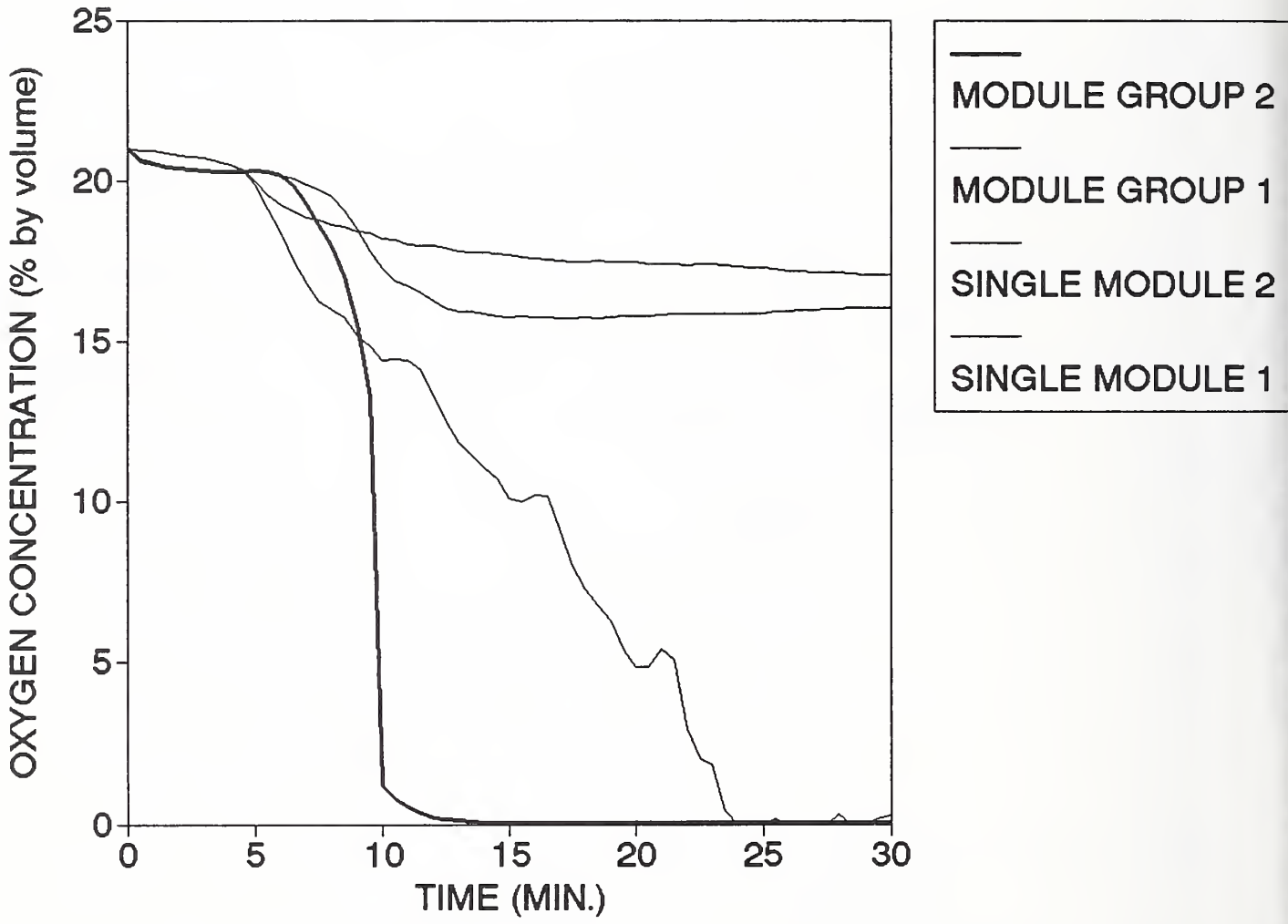

Figure 48. Oxygen in smoke in open plan area in Toledo building.

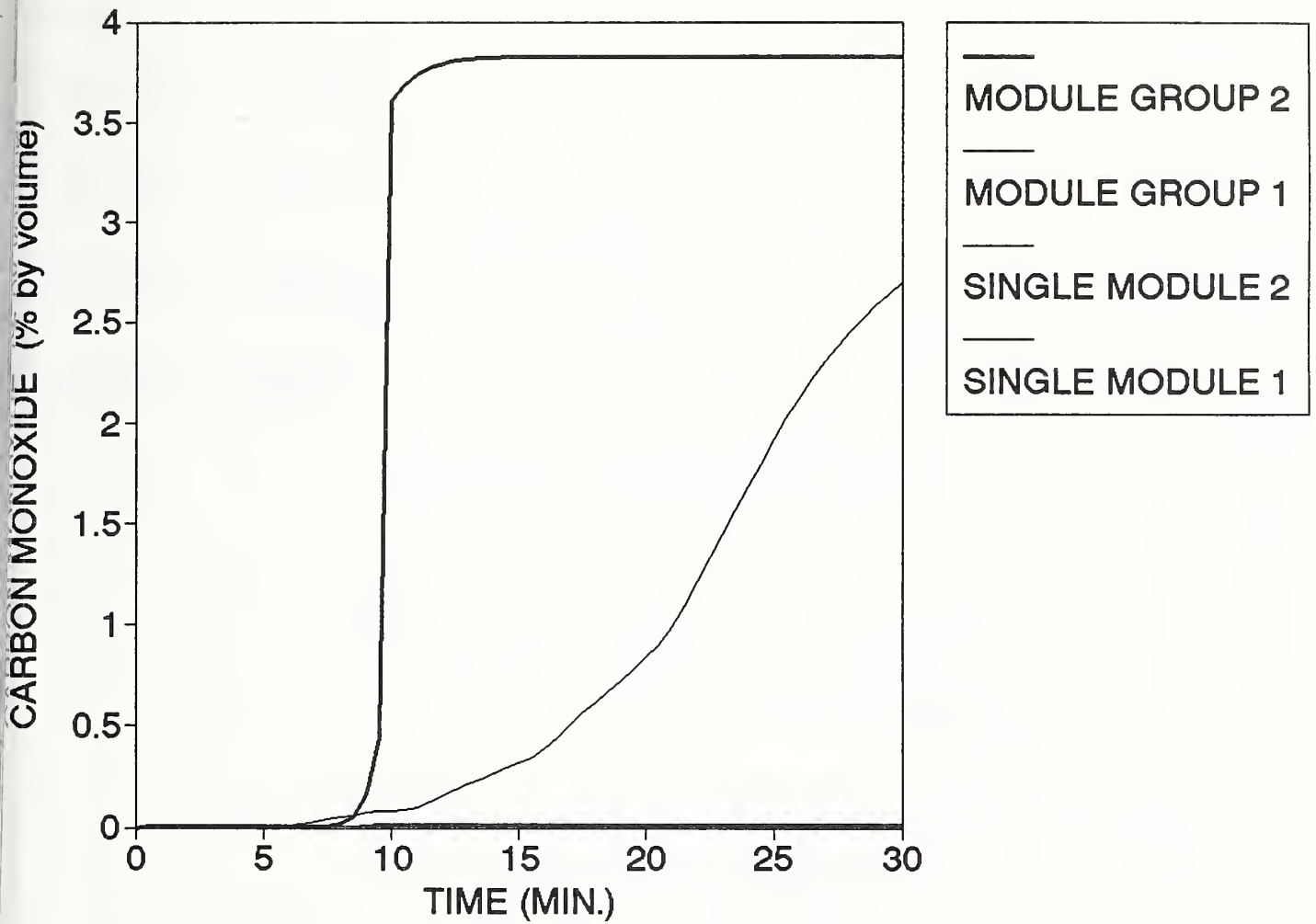

Figure 49. Carbon monoxide in smoke in open plan in Toledo building.

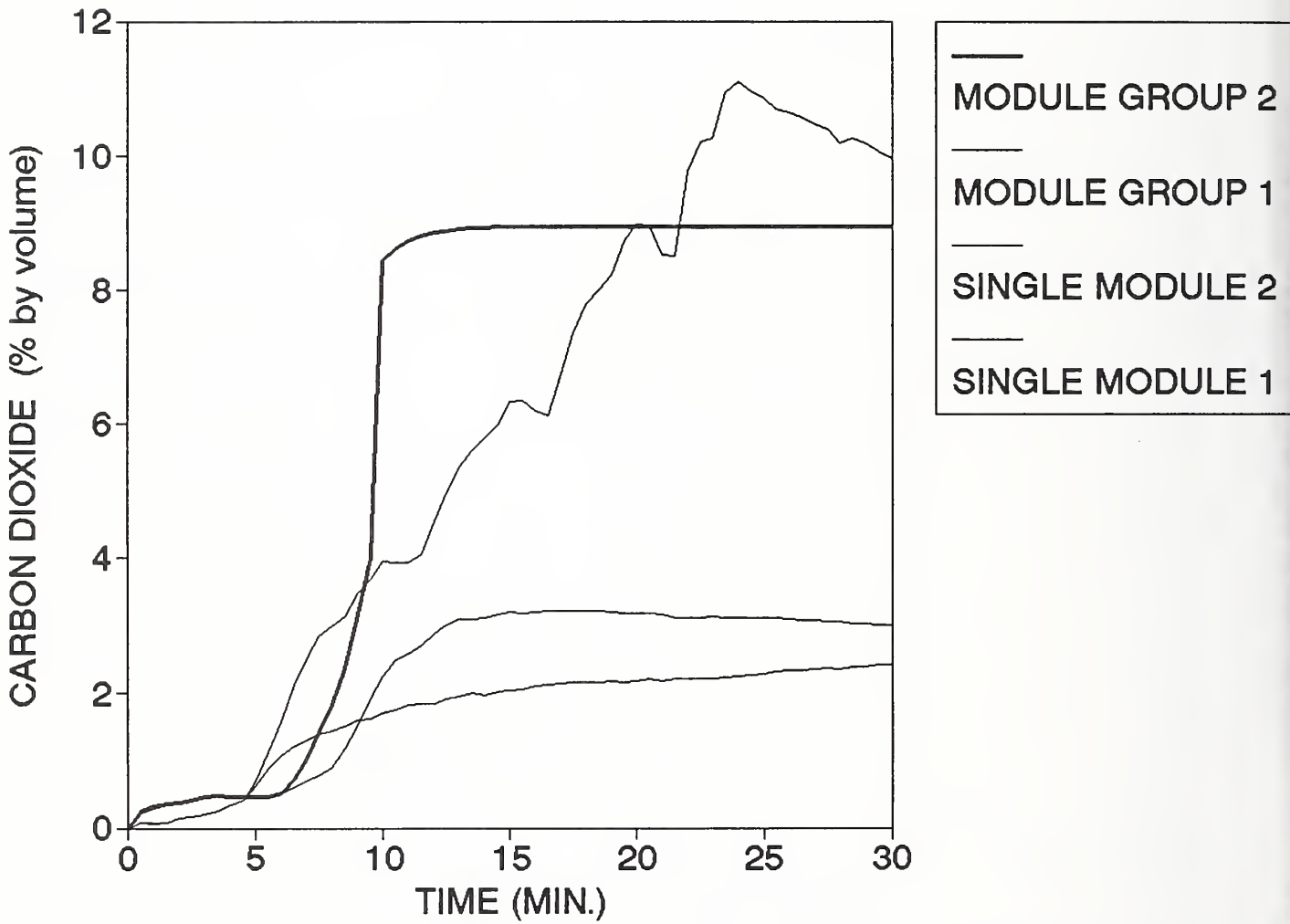

Figure 50. Carbon dioxide in smoke in open plan area in Toledo building.

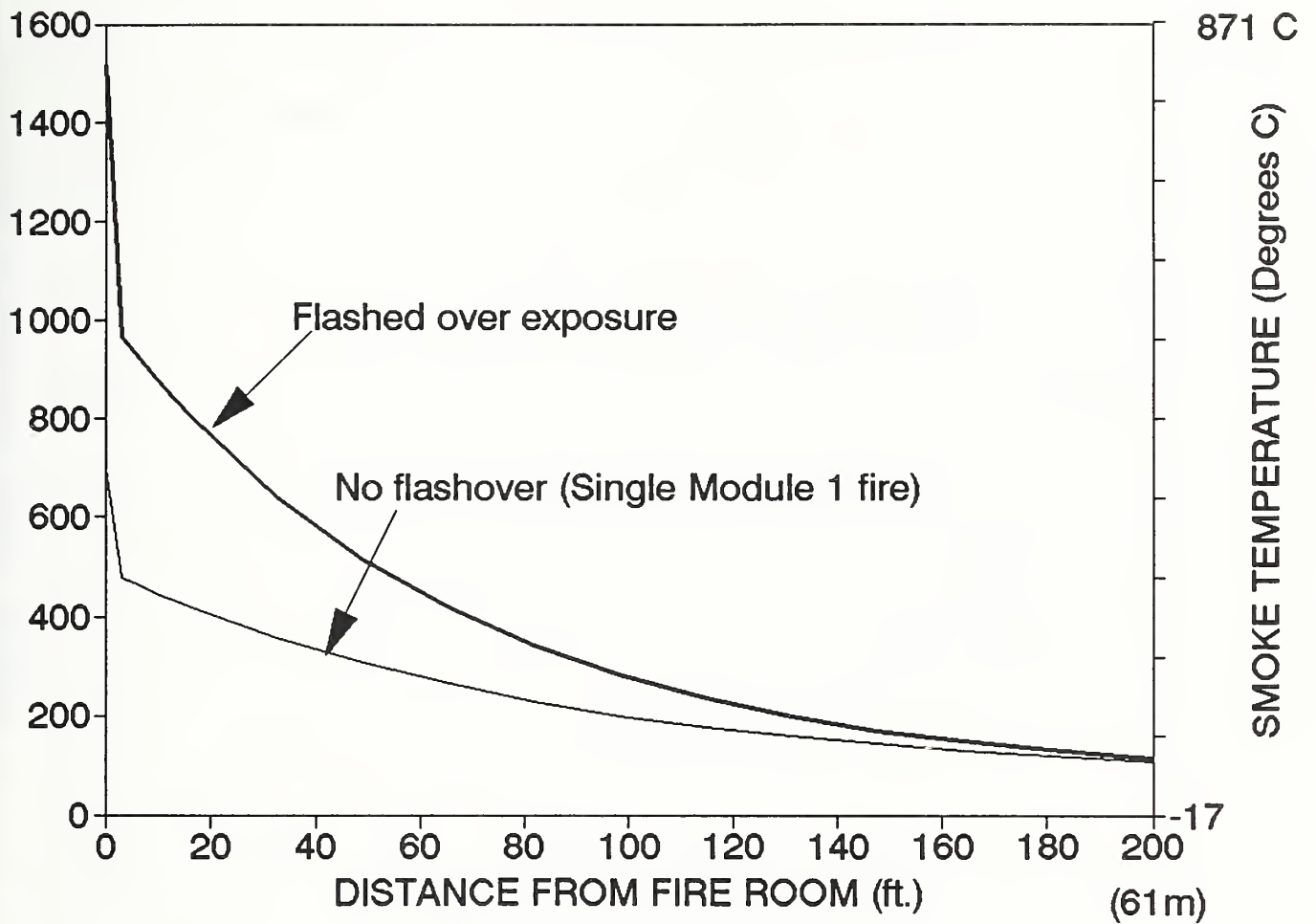

Figure 51. Temperature profiles in corridor of Toledo building

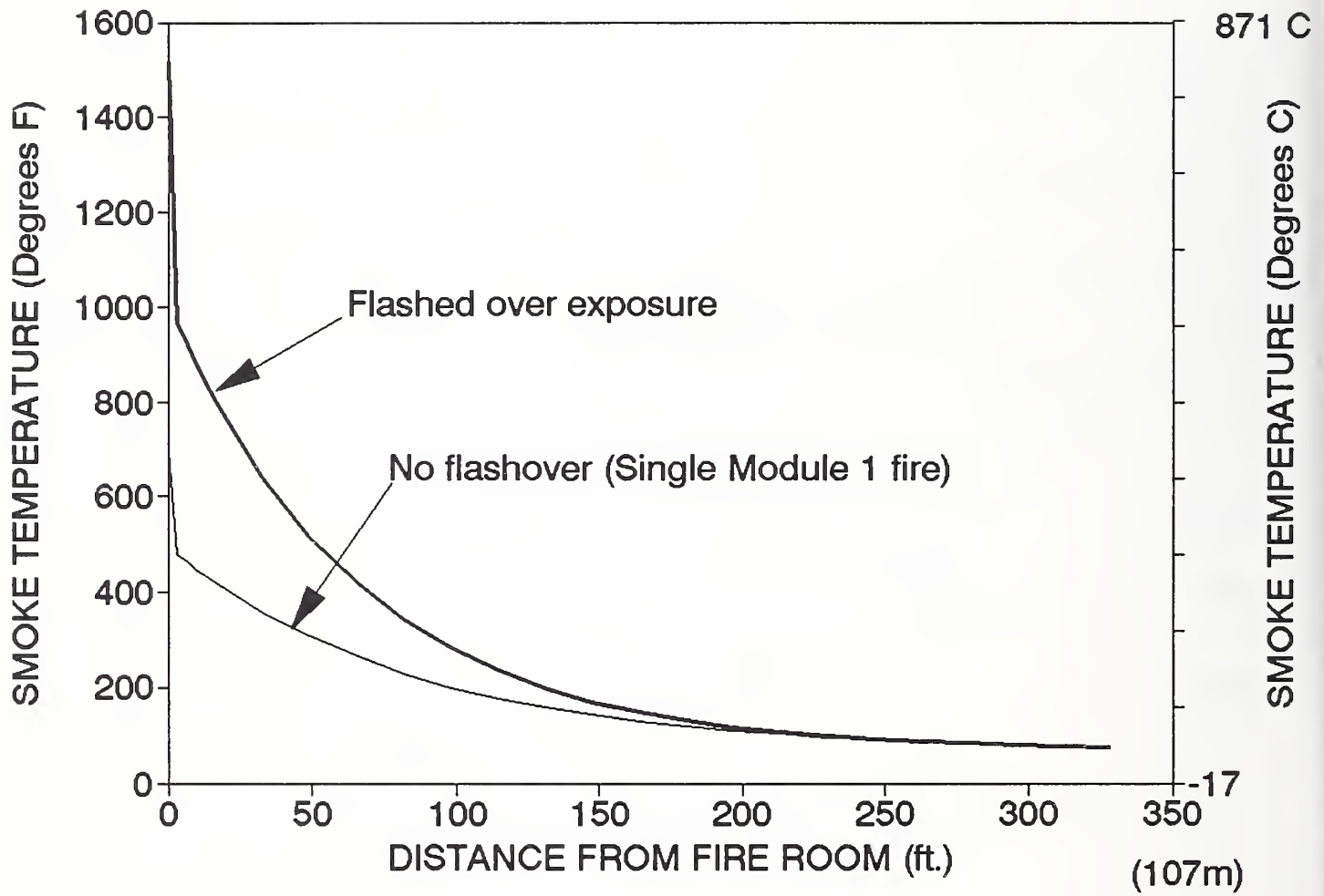

Figure 52. Temperature profiles in corridor of Cohen Building.

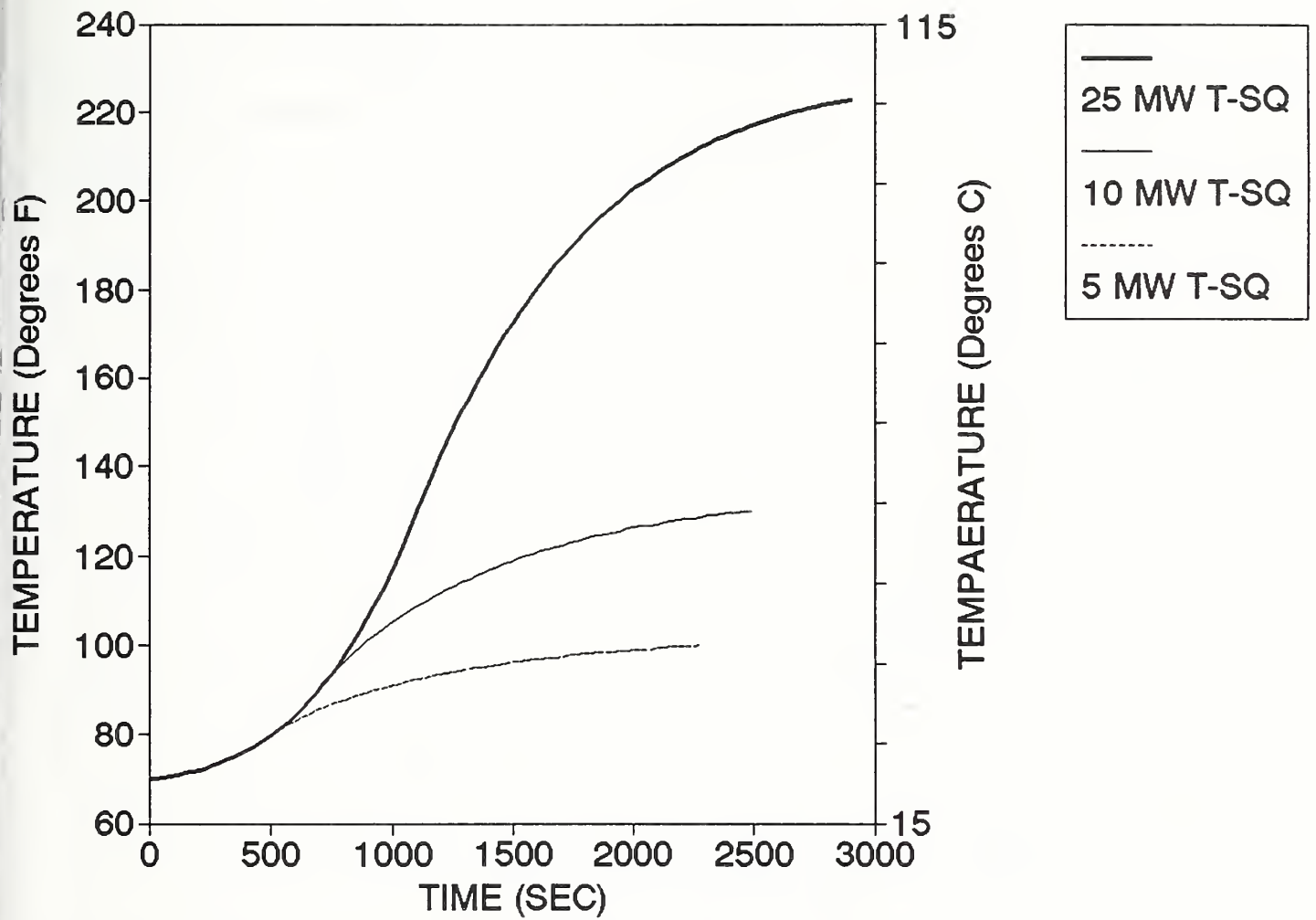

Figure 53. Smoke temperatures in atrium in Pension Building.

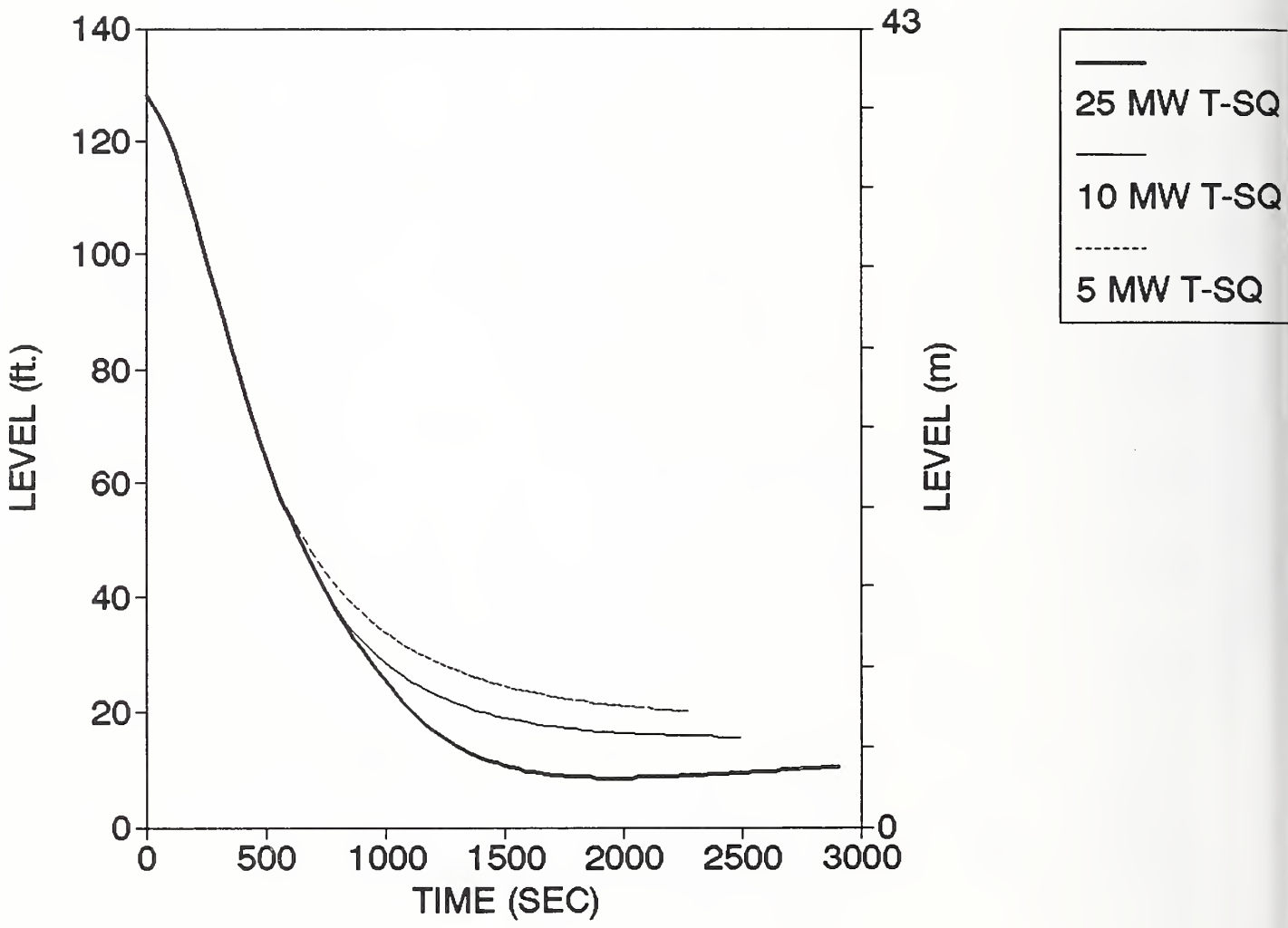

Figure 54. Smoke level in atrium in Pension Building.

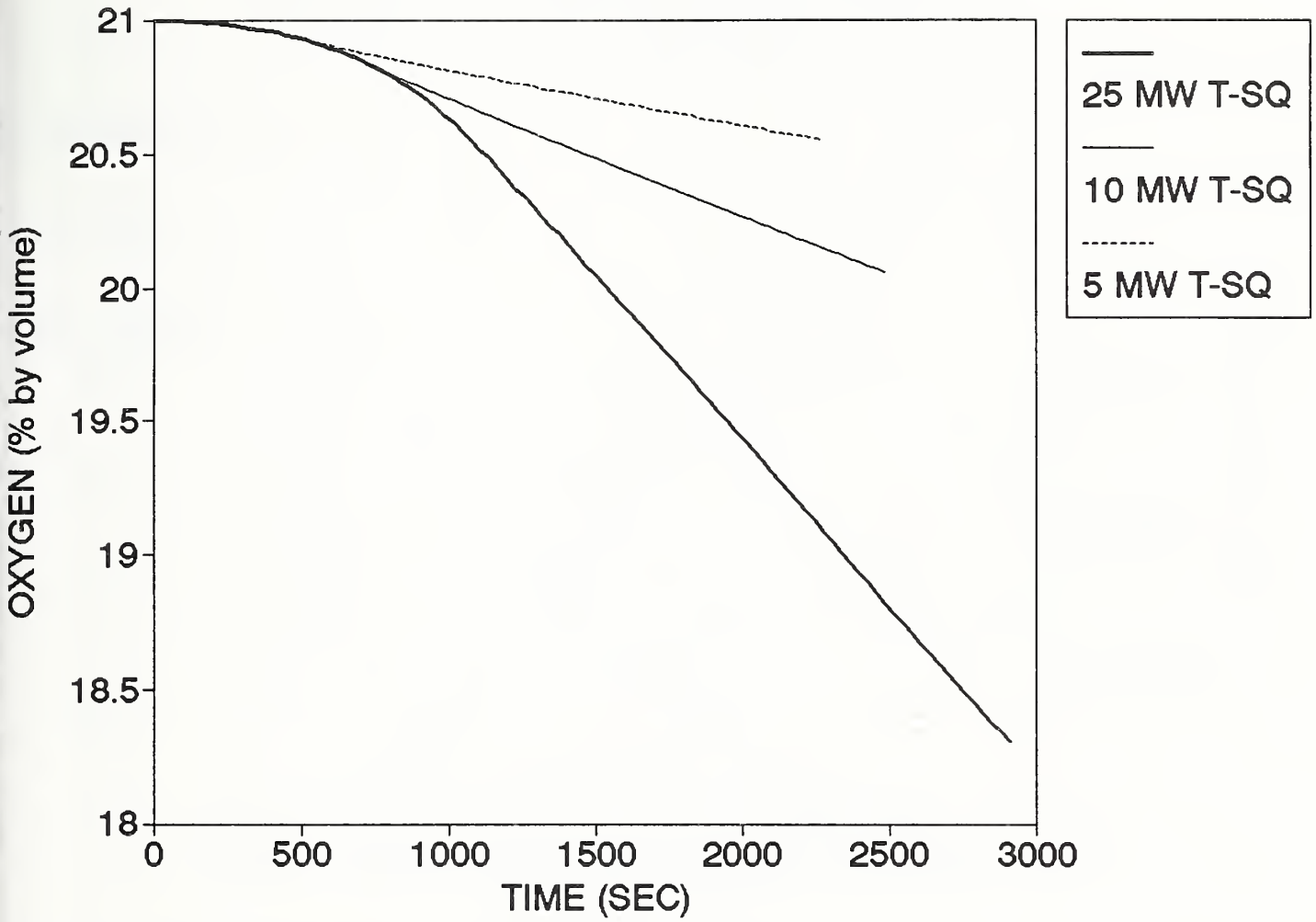

Figure 55. Oxygen in smoke in atrium of Pension Building.

CARBON MONOXIDE IN SMOKE

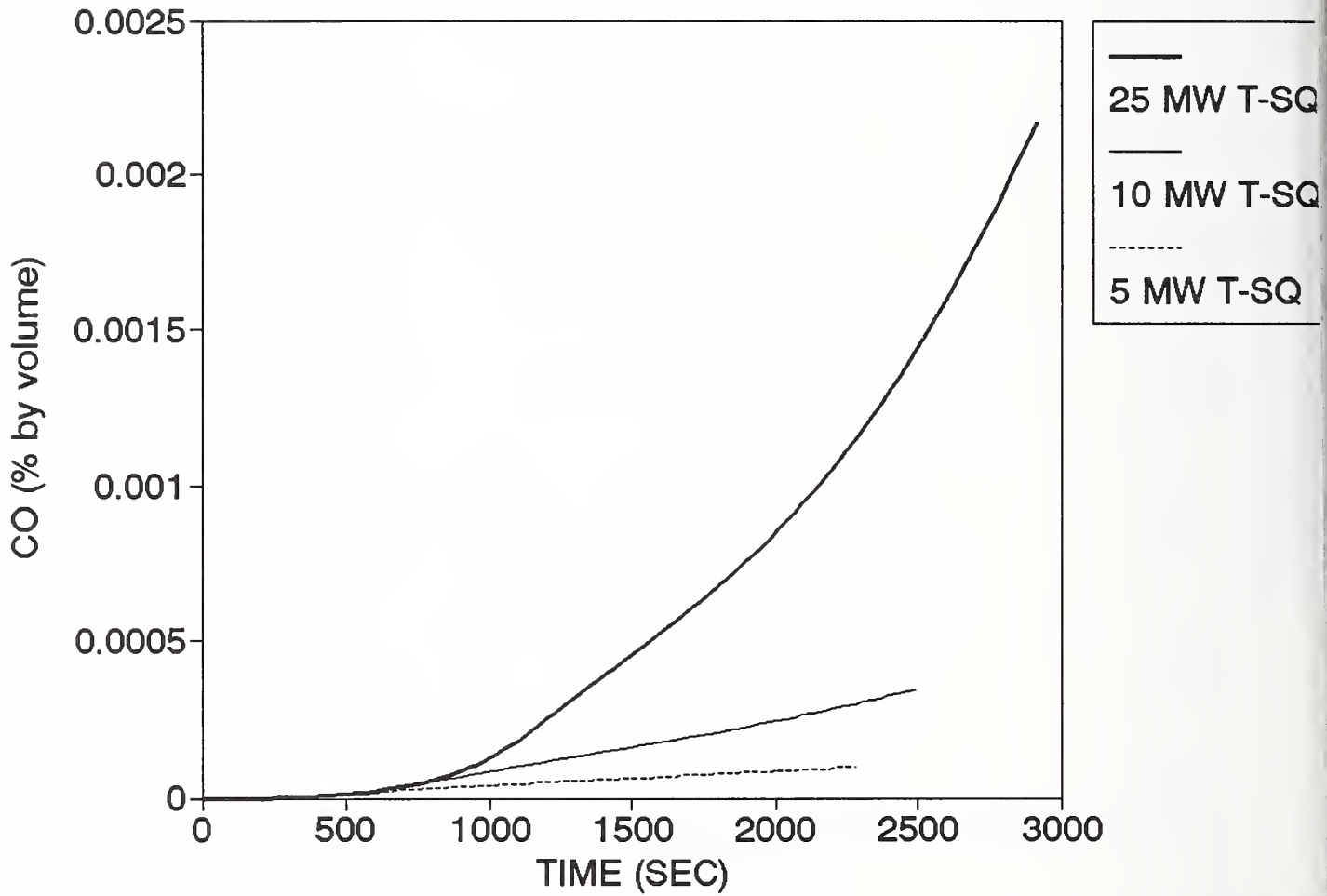

Figure 56. Carbon monoxide in smoke in atrium in Pension Building.

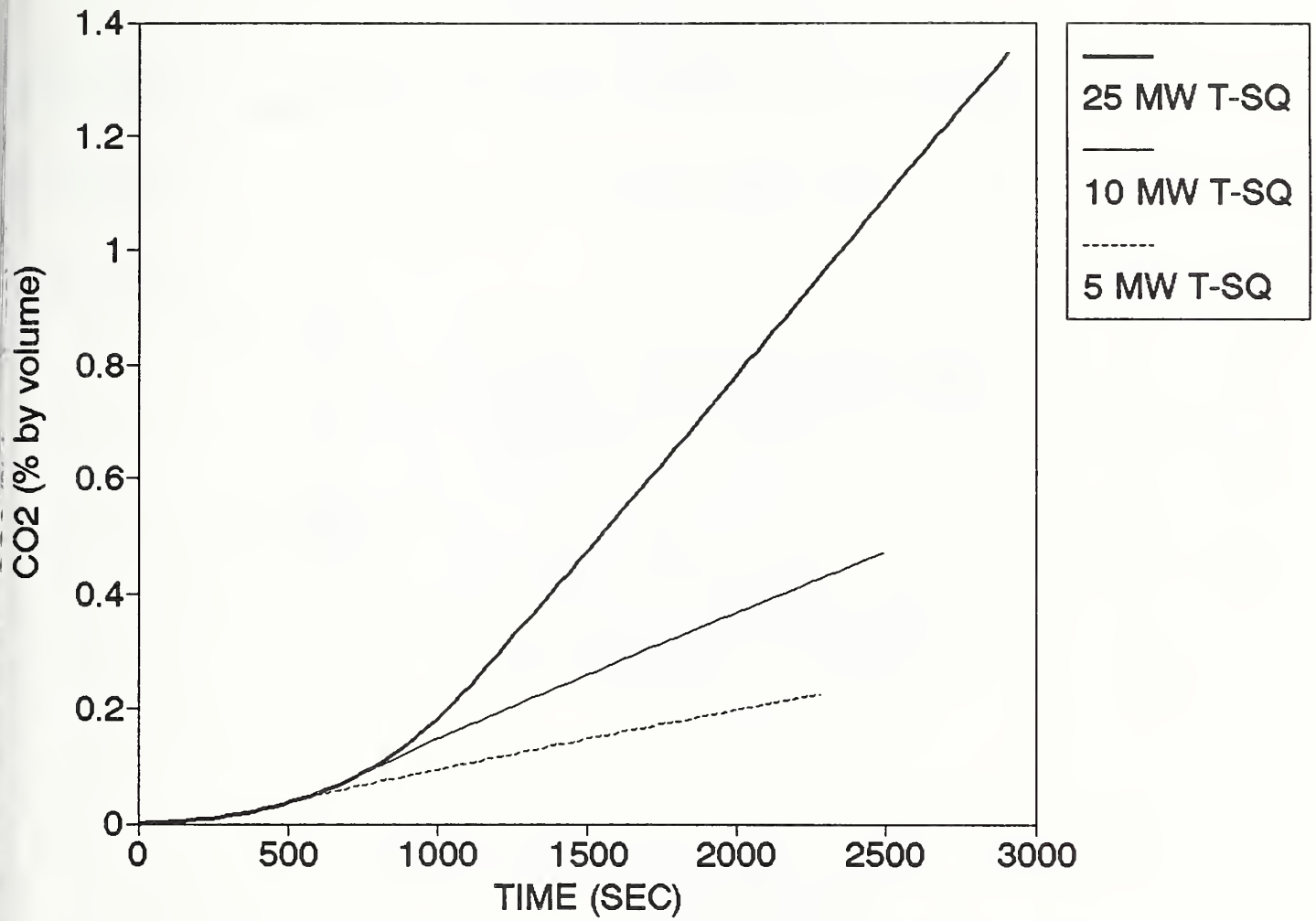

Figure 57. Carbon dioxide in smoke in atrium in Pension Building.

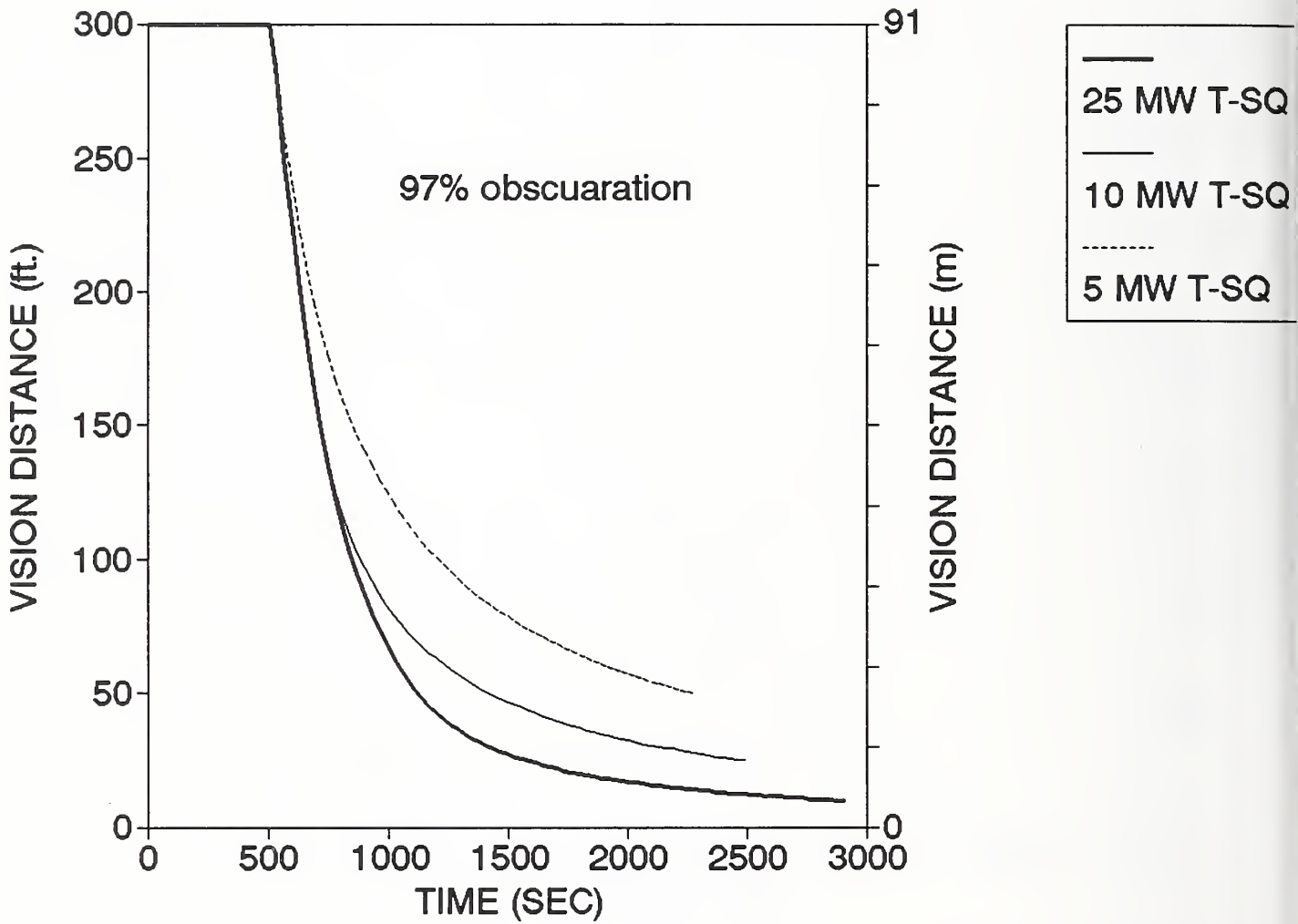

Figure 58. Vision distance in smoke in atrium in Pension Building

Appendix A

SPECIAL ANALYSIS

OFFICE BUILDING FIRES PATTERNS RELATED TO EVACUATION AND REFUGE

Prepared for: Harold E. Nelson
Building & Fire Research Laboratory
National Institute of Standards & Technology
Building 226, Room B250
Gaithersburg, MD 20899

Prepared by: Dr. John R. Hall, Jr.
Assistant Vice President
Fire Analysis & Research
National Fire Protection Association
1 Batterymarch Park, P.O. Box 9101
Quincy, MA 02269

December 1991

Summary

This is a two-part analysis of available data bases on fires in office buildings with respect to patterns that may be related to consideration of options of evacuation or refuge.

The first part is a narrative description of each of 25 fires resulting in civilian fatalities in general office buildings in the U.S. during 1971-1991, as reported to the National Fire Protection Association (NFPA) Fire Incident Data Organization (FIDO). Originally, it was expected that there would be 30 such incidents, but examination of the hard copy reports showed that one was a duplicate and four were in properties that probably were stores, not offices.

Most of the incidents involved either (a) fires in office occupancies that spread to, and caused deaths in, non-office occupancies located in the same building, or (b) fires that inflicted fatal injuries very rapidly on individuals who were very close to the ignition point, often because they were involved, accidentally or otherwise, in the ignition. Few deaths occurred in office occupancies as a result of a developing fire, where time for detection, suppression, or evacuation to the outside or a place of refuge would have been an issue. (Few of the office properties had automatic detection or suppression equipment.) Note, too, how often the fire occurred after hours and the victim was the only occupant or one of the few still there, a situation which resulted in delayed discovery of fire (in the absence of automatic detection equipment).

The 25 incidents are presented in order of number of deaths, then by year of occurrence, then alphabetically by state. Two incidents were the subject of NFPA investigations, and the published articles on those are attached, as is a *Firehouse* article on a highly publicized incident in Illinois.

The second part is a series of tables summarizing fires and civilian deaths in 1980-1989 general office building fires in the U.S., based on statistical projection of incidents reported to the U.S. Fire Administration's National Fire Incident Reporting System (NFIRS). Emphasis is placed in the analysis on the location of the fire (area of origin and level of origin), the size of the fire (extent of flame and extent of smoke), and the separation between the initial locations of fire and victim. The proportion of victims estimated to have been in the same room as the fire from the beginning is similar to the proportion in the FIDO analysis (just over one-third in both cases), but the other special circumstances identifiable in FIDO -- victims being in non-office occupancies, victims being alone or nearly alone in the building -- cannot be analyzed in the NFIRS analysis, because such data is not recorded.

It is clear that most fires and fire deaths involve fires that begin on the first or second floor, a fact which may primarily reflect the large number of

low-rise office buildings in the country. Small office buildings for doctors, dentists, realtors, lawyers, or insurance agents are quite common. In fact, three-fourths of all office buildings (78%) have less than 10,000 square feet of total floor space (Table 1261, *Statistical Abstract of the United States 1989*, Washington: U.S. Census Bureau, 1990). However, most of the total office floor space is in buildings each having more than 50,000 square feet (Table 1260, *op cit.*).

In terms of the fires, height of building has only recently been coded and even now many participating fire departments do not code this data element. Of the 1980-1989 general office building structure fires, 80% did not have height of building coded, and this included 95% of the fire deaths. Of the remainder, the largest share (37%) were in buildings less than 10 feet tall (one-story). Buildings 10-19 feet tall (usually two-story) accounted for 25%, buildings 20-29 feet tall 17%, buildings 30-49 feet tall 6%, buildings 50-69 feet tall 7%, buildings 70-100 feet tall (the cutoff for some definitions of high-rise) 4%, and buildings over 100 feet tall 2%. (What remains is 1% of fires in buildings coded as completely below grade.)

Table 1 provides a breakdown of the fires and deaths in terms of areas of origin, while Table 2 provides a breakdown in terms of level of origin. Table 3 provides breakdowns in terms of extent of flame damage and extent of smoke damage, and Tables 4-9 provide similar breakdowns for subgroups of fires defined by particular groups of areas or levels of origin.

Table 1 shows that just over one-fifth of general office building fires start in an office room, and over half the associated deaths in fires with known area of origin occur in these fires. Means of egress and structural areas are also common areas of origin for general office building fires, which is important, because these areas can pose very different problems in terms of detection and evacuation. (Fires in means of egress may block exit paths early, while fires in structural areas may develop for a long time before being discovered.)

Table 2 shows that roughly half the fires and deaths involve fires that begin on the ground floor. Roughly 90% of all deaths occur in fires that begin on or below the third floor. As noted, this probably reflects the fact that so many office buildings are at most three stories high.

Table 3 shows that nearly half the fires involve no flame damage beyond the original object of origin, and 80% involve no flame damage beyond the first room. However, two-thirds of the associated deaths occur in fires that have flame spread beyond the first room. Smoke damage also tends to be limited in extent for fires in general -- one-third having no smoke damage or damage confined to the object of origin and nearly 60% having no smoke damage beyond the first room. However, 85% of the associated deaths occur in fires that have smoke spread beyond the first room.

By themselves, these figures point to larger fires as deadlier fires, but they do not suffice to demonstrate that most victims are being killed late in the development of the fire. If one concentrates on the location of the victim, then 38% of victims were in the same room with the fire, and the other 62% were outside the room somewhere. Most (76%), however, were on the same floor as the fire and so may not have been too far from the fire, given some of the detailed descriptions in the FIDO analysis.

Based on fires with causal codes sufficient for classification purposes, 58% of the fires involved incendiary or suspicious causes. Often, these fires were set in means of egress (e.g., hallway, lobby) or places where delayed discovery was likely (e.g., attic, roof). The presence or absence of automatic detection or suppression equipment was rarely recorded, but where it was, detectors were usually present (53% of deaths) and sprinklers were not (13% of deaths). The only fire deaths recorded in the presence of sprinklers involved a victim in the room with a fire started by torch operations on a wall; this suggests that the victim and fire were close from the outset. The only deaths recorded in the presence of detectors involved the same torch/wall fires or incendiary fires.

Also, 80% of the deaths occurred at a time or on a day that would be well outside of normal work hours in any office.

Collectively, these statistics point to a number of common fatal-fire scenarios involving circumstances where the effectiveness of any provisions for evacuation or refuge might be reduced:

- A victim is so close to the fire at the start that no effective reaction can occur in time to save him or her. This typically involves workers or arsonists.
- Fire occurs in a building where there are no detectors or where the detectors are not working, leading to delayed discovery of fire, possibly compounded by the speed of the fire (e.g., an arson fire using accelerants), the hidden location of the fire, or the fact that the fire occurs after hours when fewer people are present to discover it.

Not shown here are some of the other complicating factors revealed in the FIDO analysis, such as office fires whose victims are in non-office occupancies in the same building and victims who evacuate successfully but are killed when they return to the building.

For all these reasons, the adequacy of evacuation arrangements may not be among the most critical factors in addressing the causes of recent office fire deaths. However, relaxation of those arrangements could lead to increased risk, since there is no way to know from most of this data how narrow the escapes were of those were not killed.

For evaluation of alternatives, the most useful material here may be Tables 3-9, which indicate the extent of fire and smoke one may encounter in office building fires, patterns which tend to differ only marginally as a function of the area or level of origin of the fire. These fire size tables may be useful in defining benchmark fires with which to "challenge" various arrangements, using engineering calculations.

FIDO Summary

1. Georgia, 1989 (4 deaths).

This is the Peachtree 25th Building fire in Atlanta. (See attached published NFPA investigation report.)

2. Pennsylvania, 1972 (3 deaths).

Fire began in a first-floor office of a three-story, 65 foot by 18 foot building with apartments on upper floors. The building was of wood construction with brick walls and a tar and paper roof covering. Combustible structural members were in contact with a chimney and were ignited by sparks and/or hot gases escaping through a hole in the chimney. Walls were not firestopped and had wood paneling, and stairwells were unprotected. All three deaths were elderly occupants of third-floor apartments, whose windows were blocked by iron bars. The second floor was unoccupied; no one escaped. The building had rate-of-rise heat detectors, which operated, and no sprinklers.

3. Oklahoma, 1983 (2 deaths).

Two workers died in an explosion and flash fire that began when their paint sprayer developed a leak in its feed line and lacquer was leaked onto the sprayer motor. The one-story brick and wood-frame building housed an insurance and real estate sales office. The sprayer had problems with its armature brushes, which led to an arc, which ignited the leaked lacquer fumes. The two victims reportedly died instantly.

4. Washington, 1972 (2 deaths).

This three-story building, 40 feet by 100 feet, of wood frame and concrete construction had a real estate company on the first floor and apartments overhead. A gas main was ruptured by a backhoe, and natural gas built up in the basement over several hours, then exploded just before 2:00 a.m. A pilot light in the real estate office ignited the fire, which killed two apartment residents, trapped on an upper floor. There were no automatic detectors or sprinklers. The initial explosion blew the basement garage doors 200 feet away and removed all the interior partitions, including several load-bearing walls, causing all floors to sag significantly even before the fire damage that followed the explosion.

5. California, 1991 (1 death).

Fire began when an electrical worker was removing cartridge fuses from a live electrical panel, where the main fuse bus had not been disconnected. As he removed the third fuse, it grounded and exploded, triggering the fire. The initial arc created additional arcing in 2,000 ampere conductors, whose riser had no ground fault protection. The 64-year-old worker who was killed died of his burns the day after the fire.

The 18-story building of fire-resistive construction lost power when the fire began at 9:30 a.m. in a second-story electrical room. Backup power failed to come on when the emergency generator failed to operate. Fire was confined to the room of origin and adjacent lobby, but smoke extended to multiple floors and entered some exit stairways. Exiting occupants found the ground-floor door locked in one stairway and had to climb five to six floors to move to another stairway. Two occupants were trapped in an elevator near an upper floor for an hour and a half, and one woman in a wheelchair on the 13th floor took considerable time and resources to evacuate but was deemed to have been in no danger where she was.

There were no automatic detectors or sprinklers in the building.

6. Florida, 1990 (1 death).

The owner was killed while setting an arson fire in his business in this three-story, 50 foot by 78 foot office building. He poured 150 gallons of gasoline on the third floor. An incendiary device he planted failed to operate, so the owner returned and tried to ignite the fire with his lighter, held at floor level. The rapidly developing fire killed him.

7. California, 1988 (1 death).

This is the First Interstate Bank Building fire. (See two attached reports published in NFPA journals.)

8. California, 1987 (1 death).

The victim was working late in a 15 foot by 30 foot office occupancy in a strip commercial property. The 2:00 a.m. fire was an arson murder in which gasoline was poured inside the front door, possibly through a mail slot, and ignited. The arson apparently was part of a protection-racket extortion campaign against the commercial property owners of the area. Officials say the victim was trapped because the only exit was locked; it is not clear whether they mean to say the door where the fire was started was also locked or whether the locked door was the second way out. There were

no automatic detectors or sprinklers in the property. The construction was wood frame and cement block with glass front walls and a composition roof.

9. Illinois, 1987 (1 death).

See also the attached article from *Firehouse* on this fire.

A 31-year-old production manager for an advertising agency was working very late at the agency's 20th floor offices in the this 30-story office building. The building was of fire-resistive construction and is 270 feet by 125 feet. The floor of origin has roughly 150 offices and partitioned cubicles in a floor area of 38,000 square feet. The four stairways serving the floor are located in the interior of the floor.

Fire began in a production room for mounting and viewing of materials. Investigators found roughly 30 one-gallon cans of cements and solvents, labeled "highly flammable," in the room, along with film negatives and other materials comprising a heavy fuel load capable of burning quickly and intensely. Investigators concluded the fire was accidental but could not resolve the cause. Several pieces of equipment had been left on, and most of the people who used the room, including the victim, were smokers.

Officials used the term flashover to describe the fire in the room of origin. They also saw evidence of a long initial smoldering period. They found a "fire line" four to five feet above the floor extending some distance from the room of origin in several directions.

There were no sprinklers in the building, but it did have smoke detectors. Their performance was not described, and it was estimated that the fire burned for 15 minutes before the victim discovered it and phoned the emergency number. She then moved away from the fire, which probably meant moving away from the stairways, and called her father, saying she had moved away from the fire and was trapped. She hung up, saying the smoke was too thick, and called the emergency number again, repeating her location and situation and adding repeatedly her fear that she was going to die.

First responding units arrived at about the same time as her second call to the emergency number, which was just over three minutes after the first call. The dispatcher directed the officers toward the victim's location but apparently did not specify that someone was trapped there. Fire officers encountered problems with the elevator controls, as the elevator did not open at the selected floor, three floors below the fire floor, but opened a crack, closed, and went to the fire floor, where fire fighters had to hold the doors shut manually to prevent exposure to intense fire conditions. It took 20 minutes to move and extricate the trapped crew. Another crew attacked the fire without delays and were informed at some point that a woman was trapped. When they reached the floor of the fire, they encountered

temperatures estimated in the range of 1,000 to 1,500 degrees Fahrenheit, based on the pattern of damage to doors and aluminum window frames. The intense heat and heavy smoke, combined with the floor's maze-like layout, prevented fire fighters from locating the victim until late in the fire control process, by which time it was too late to save her.

10. Kansas, 1986 (1 death).

A woman was killed when a propane-fueled heater exploded in an office serving a campground. No other details were available.

11. Ohio, 1986 (1 death).

Fire involved a 15-story bank and insurance office building with retail shops on the first floor. The building was of fire-resistive, concrete construction, with a built-up roof covering. The victim was one of several workers who were operating on a 440-volt electrical panel in an 18 foot by 12 foot electrical panel room on the eighth floor, just after 5:30 p.m. A large electrical arc, apparently from a short circuit, occurred and ignited many items in the room, including clothing on several workers. Fire was confined to the room, except for the fire carried out of the room by burning people. Smoke spread out of the open door, activating the automatic detectors (and alerting the alarm supervision company) and the computer room's halon system. There was also a wet-pipe sprinkler system, but the electrical panel room was not covered, and it did not activate. In all, 15 people were injured or killed.

12. Kansas, 1985 (1 death).

A woman was killed when a propane furnace exploded in the office of a private campground. There were no other details.

13. California, 1983 (1 death).

This fire began as a result of an electrical short circuit in a typewriter in a secretarial station on the upper floor of a two-story, 10,000 square foot, brick and wood-frame building. A small office party was under way when someone smelled smoke and discovered the fire at 9:33 p.m. (There were no automatic detectors, and sprinklers were located only in the basement garage.) All but three of the occupants exited immediately. Two stayed and tried unsuccessfully to fight the fire with portable extinguishers. The last occupant was discovered to be still inside after everyone else had exited, at least one having to crawl under the smoke and heat. The victim had been in another office, several offices away from the party and the fire. He may

not have realized there was a fire until it was too late. He was heard calling for help during the fire. Foul play was ruled out.

14. Texas, 1983 (1 death).

This incident involved a state government legislative building with an apartment suite for the lieutenant governor. Fire began in this apartment space, apparently accidentally although the cause was not determined. Fire began shortly after 5:00 a.m. in the den area of the suite on the second floor. Fire spread via the hallways in several directions and burned through the den's ceiling into concealed spaces and from there to the third floor. The six-story building was of heavy timber, protected ordinary construction, with granite walls and a metal roof. It was closed for the night.

The victim was a young adult male overnight guest, apparently impaired by alcohol, who was found between two beds in a bedroom across a hallway from the den where the fire began. Three other suite occupants escaped unharmed. The property had sprinklers only in the basement. There were smoke detectors in the suite, but their performance was undetermined.

15. Illinois, 1980 (1 death).

Only news accounts are available for this incident, and they leave many important points unaddressed. The victim was an elderly attorney but in excellent health. He died in his office, one of several offices located above a ground floor retail store. The cause and initial location of the fire were not clearly described, but it was first discovered in a hallway serving the offices and may have blocked that exit early. There was a second way out via windows which let out onto a roof, but the victim did not try this route. The article mentions rumors, deemed to be unfounded, of a bomb and of rifled files. All such events were deemed by fire officials, according to the news account, to have occurred in the normal course of fire development or fire fighting.

16. California, 1979 (1 death).

A group of workers were having difficulty removing vinyl floor covering and so tried to loosen the material by pouring half a gallon of gasoline on it. The gasoline vapors were ignited by the pilot light of a wall heater. Fire began in the offices of a paving company and damaged much of the building and two curbside vehicles outside. The one-story, 20 foot by 51 foot building was of wood construction with a concrete slab floor and an asphalt roof. Exposed roof joists and wood wall paneling added to fire spread. There were no automatic detectors or sprinklers.

The victim was the business owner. He entered the work area after the gasoline was poured and had just voiced concern over the danger when fire erupted, igniting his clothing. He then ran into an office rather than an exit door four feet away. It took more than one try before he could be pulled out a window, and by then, his injuries were mortal. He died minutes later.

17. Florida, 1978 (1 death).

A 62-year-old man, blocked by a door kept locked for security reasons, died in a fire in his real estate office, a one-story, 40 foot by 60 foot concrete block building with a built-up roof. An electric-powered hot plate malfunctioned and ignited nearby wood paneling in a records and supply room. Fire growth was fed by high-piled stacks of records. There were no automatic detectors or sprinklers in the property. Fire was discovered by a passerby, who reported it to the wrong fire department, further delaying response.

18. Kentucky, 1978 (1 death).

A city government office building that measured 75 feet by 60 feet and was two stories high, with wood construction and brick walls, was the site of this fatal fire. Overloaded wiring reportedly ignited wooden ceiling components on the first floor. A long smoldering period produced a build-up of unburned fuel in gaseous form in a small space, termed an enclosure. This then was ignited in what fire officials called a flashover condition. Fire spread was increased by the lack of fire walls, the lack of stairwell enclosures, and the presence of new paint and oil treatments on office furniture and floors. The building had no automatic detectors or sprinklers. The only occupant at the time of the fire was a 78-year-old retired fire fighter who served as caretaker. He apparently called in the fire but was unable to escape. His location and movements were not reported.

19. New York, 1977 (1 death).

Fire began in a first-floor attorney's office, then spread through a grocery store and a restaurant before spreading to upper-floor apartments, where one resident was killed. Several other residents were rescued by fire officials. No other details were available.

20. California, 1976 (1 death).

A short news clip provides few details on the fatal fire in this four-story office building. A worker was killed, and 15 people had to be rescued by ladder from windows. The worker was a carpenter who was remodeling a third-story office. No details on cause or the circumstances of the victim's fatal injury were available.

21. California, 1976 (1 death).

The victim maintained a bed in his real estate office, a 360 square foot office in a 1,800 square foot, one-story building of masonry block construction on a wood frame with a tar and gravel roof. The victim passed out near his bed from alcohol consumption, and his lit cigarette ignited the bedding. There were two other businesses in the building.

22. Alabama, 1975 (1 death).

A city office building was the site of a fire that killed an inmate of the jail located on the premises. The only two other people in the building escaped unharmed. The one-story building had been constructed earlier that year. There was no information on the building's construction or on the cause, initial location and growth path of the fire.

23. New York, 1975 (1 death).

There were few details on this 13th floor fire. No information was provided on the fire cause, the size or construction of the building, or the on-site fire protection systems. The victim, a 76-year-old male, was reported to have died after re-entering the building following a successful evacuation.

24. Alabama, 1974 (1 death).

There were no details available at all on this fire, the victim, or the building in which the fire occurred.

25. Illinois, 1974 (1 death).

A man walked into a currency exchange office and used two cans of gasoline (with at least six gallons of gasoline, based on testimony from someone who saw him purchase gasoline just before the incident) to set a fire that killed a 26-year-old pregnant cashier. The two-story building also had three retail stores on the ground floor and apartments on the upper floor. All other occupants escaped unharmed.

**Table 1. General Office Building Fires, by Area of Origin
Annual Average of 1980-1989 Structure Fires
Reported to U.S. Fire Departments**

Area of Origin	Fires	Deaths
Means of Egress		
Hallway or corridor	593	0*
Exterior stairway	84	0
Interior stairway	108	0
Escalator	1	0
Lobby or entrance way	318	0*
Unclassified	51	0
Assembly or Sales Area		
Auditorium, lecture hall, theater or other large assembly area (100 or more people) with fixed seats	13	0
Large open room (100 or more people) without fixed seats	34	0
Meeting room or other small assembly area (fewer than 100 people)	208	0
Lounge	179	0*
Sales or showroom area	183	0
Library	7	0
Unclassified	21	0
Function Area		
Bedroom	42	0
Dining area, lunchroom or cafeteria	96	0
Kitchen	352	0
Bathroom, cloakroom or locker room	631	0
Laundry room	36	0
Office	2,631	3
Health club or other personal service area	9	0
Laboratory	32	0
Printing or photographic room or area	68	0
First aid or treatment room	9	0
Operating room	3	0
Electronic equipment room or area	292	0
Performance or stage area	3	0
Projection room or area	5	0
Process or manufacturing area	91	0
Unclassified	85	0

* Not zero but rounds to zero

**Table 1. General Office Building Fires, by Area of Origin
Annual Average of 1980-1989 Structure Fires
Reported to U.S. Fire Departments
(Continued)**

Area of Origin	Fires	Deaths
Storage Area		
Product storage room or area	122	0
Closet	157	0
Supply storage room or area	545	0
Records storage room or vault	136	0
Shipping, receiving or loading area	73	0
Trash area	272	0
Garage	122	0*
Unclassified	68	0
Service Facility		
Elevator or dumb-waiter	171	0
Utility shaft	48	0
Light shaft	15	0
Chute	11	0
Duct	125	0
Display window	9	0
Chimney	38	0
Conveyor	1	0
Unclassified	30	0
Service or Equipment Area		
Machinery room or area	370	0
Heating equipment room or area	572	0
Switchgear area or transformer vault	160	0*
Incinerator room or area	18	0
Maintenance shop or area	62	0
Test cell	1	0
Enclosure with pressurized air	2	0
Enclosure with enriched oxygen atmosphere	1	0
Unclassified	56	0

* Not zero but rounds to zero

**Table 1. General Office Building Fires, by Area of Origin
Annual Average of 1980-1989 Structure Fires
Reported to U.S. Fire Departments
(Continued)**

Area of Origin	Fires	Deaths
Structural Area		
Crawl space or substructure space	184	0
Exterior balcony or open porch	81	0
Ceiling/floor assembly or concealed space	237	0*
Ceiling/roof assembly or concealed space (includes attic)	471	0
Wall assembly or concealed space	211	0*
Exterior wall surface	536	0
Exterior roof surface	533	0*
Awning	38	0
Unclassified	117	0
Transportation or Vehicle Area		
Passenger area of vehicle	7	0
Trunk or load-carrying area of vehicle	3	0
Engine, gear, or wheel area of vehicle	16	0
Fuel tank or fuel line area of vehicle	4	0
Operating or control area of vehicle	1	0
Exterior exposed surface of vehicle	4	0
Unclassified	3	0
Other Area		
Near railroad right of way or embankment	1	0
Near highway or street	25	0
Court, terrace or patio	21	0
Lawn, field or open area	34	0
Wildland area or woods	0*	0
Multiple areas	127	0
Area of origin not applicable	79	0
Unclassified	118	0
Unknown	537	1
Total	12,758	7

* Not zero but rounds to zero

**Table 2. General Office Building Fires, by Level of Origin
Annual Average of 1980-1989 Structure Fires
Reported to U.S. Fire Departments**

Level of Origin	Fires	Deaths
Below grade level	1,040	0
Grade level to 9 feet above grade	6,548	4
10-19 feet above grade	1,920	2
20-29 feet above grade	577	1
30-49 feet above grade	511	0
50-70 feet above grade	289	0
Over 70 feet above grade	649	1
Objects in flight	31	0
Unclassified	33	0
Unknown	1,159	0
Total	12,758	7

**Table 3. General Office Building Fires, by Extent of Flame and Smoke
Annual Average of 1980-1989 Structure Fires
Reported to U.S. Fire Departments**

Extent of Flame Damage	Fires	Deaths
No flame damage	5 (0.0%)	0
Confined to object of origin	6,108 (47.9%)	0*
Confined to area of origin	1,899 (14.9%)	1
Confined to room of origin	2,176 (17.1%)	1
Confined to fire-rated compartment of origin	111 (0.9%)	0
Confined to floor of origin	536 (4.2%)	1
Confined to building of origin	1,617 (12.7%)	3
Extended beyond building of origin	307 (2.4%)	0*
Total	12,758	7

Extent of Smoke Damage	Fires	Deaths
No smoke damage	1,865 (14.6%)	1
Confined to object of origin	2,327 (18.2%)	0
Confined to area of origin	1,182 (9.3%)	0*
Confined to room of origin	1,984 (15.6%)	0
Confined to fire-rated compartment of origin	152 (1.2%)	0
Confined to floor of origin	1,337 (10.5%)	1
Confined to building of origin	3,335 (26.1%)	5
Extended beyond building of origin	576 (4.5%)	1
Total	12,758	7

* Rounds to zero but is not zero

Fires with extent of damage unknown have been proportionally allocated. Sums may not equal totals because of rounding error.

**Table 4. General Office Building Fires, by Extent of Flame and Smoke
Fires Originating in an Office Room
Annual Average of 1980-1989 Structure Fires
Reported to U.S. Fire Departments**

Extent of Flame Damage	Fires	Deaths
No flame damage	1 (0.0%)	0
Confined to object of origin	1,036 (39.4%)	0*
Confined to area of origin	400 (15.2%)	0
Confined to room of origin	527 (20.0%)	0
Confined to fire-rated compartment of origin	26 (1.0%)	0
Confined to floor of origin	173 (6.6%)	1
Confined to building of origin	406 (15.4%)	2
Extended beyond building of origin	63 (2.4%)	0
Total	2,631	3

Extent of Smoke Damage	Fires	Deaths
No smoke damage	276 (10.5%)	0*
Confined to object of origin	407 (15.5%)	0
Confined to area of origin	210 (8.0%)	0
Confined to room of origin	434 (16.5%)	0
Confined to fire-rated compartment of origin	38 (1.4%)	0
Confined to floor of origin	358 (13.6%)	0*
Confined to building of origin	789 (30.0%)	2
Extended beyond building of origin	121 (4.6%)	0
Total	2,631	3

* Rounds to zero but is not zero

Fires with extent of damage unknown have been proportionally allocated. Sums may not equal totals because of rounding error.

**Table 5. General Office Building Fires, by Extent of Flame and Smoke
Fires Originating in a Classified Means of Egress
Annual Average of 1980-1989 Structure Fires
Reported to U.S. Fire Departments**

Extent of Flame Damage	Fires	Deaths
No flame damage	1 (0.1%)	0
Confined to object of origin	596 (53.9%)	0
Confined to area of origin	165 (15.0%)	0
Confined to room of origin	171 (15.5%)	0*
Confined to fire-rated compartment of origin	8 (0.7%)	0
Confined to floor of origin	31 (2.8%)	0
Confined to building of origin	122 (11.1%)	0*
Extended beyond building of origin	11 (1.0%)	0
Total	1,104	1

Extent of Smoke Damage	Fires	Deaths
No smoke damage	164 (14.9%)	0
Confined to object of origin	259 (23.4%)	0
Confined to area of origin	135 (12.2%)	0
Confined to room of origin	160 (14.5%)	0
Confined to fire-rated compartment of origin	12 (1.1%)	0
Confined to floor of origin	108 (9.7%)	0*
Confined to building of origin	232 (21.0%)	0*
Extended beyond building of origin	35 (3.1%)	0
Total	1,104	1

* Rounds to zero but is not zero

Fires with extent of damage unknown have been proportionally allocated. Sums may not equal totals because of rounding error.

**Table 6. General Office Building Fires, by Extent of Flame and Smoke
Fires Originating in a Structural Area
(Excluding Awnings and Unclassified and Unknown-Type Areas)
Annual Average of 1980-1989 Structure Fires
Reported to U.S. Fire Departments**

Extent of Flame Damage	Fires	Deaths
No flame damage	0 (0.0%)	0
Confined to object of origin	977 (43.4%)	0
Confined to area of origin	440 (19.5%)	1
Confined to room of origin	323 (14.4%)	0
Confined to fire-rated compartment of origin	22 (1.0%)	0
Confined to floor of origin	80 (3.5%)	0
Confined to building of origin	328 (14.6%)	0
Extended beyond building of origin	82 (3.7%)	0*
Total	2,252	1

Extent of Smoke Damage	Fires	Deaths
No smoke damage	487 (21.6%)	0*
Confined to object of origin	418 (18.6%)	0
Confined to area of origin	215 (9.5%)	0
Confined to room of origin	278 (12.3%)	0
Confined to fire-rated compartment of origin	21 (0.9%)	0
Confined to floor of origin	137 (6.1%)	0
Confined to building of origin	562 (25.0%)	0
Extended beyond building of origin	134 (6.0%)	1
Total	2,252	1

* Rounds to zero but is not zero

Fires with extent of damage unknown have been proportionally allocated. Sums may not equal totals because of rounding error.

**Table 7. General Office Building Fires, by Extent of Flame and Smoke
Fires Originating at a Level Below 10 Feet Above Grade
Annual Average of 1980-1989 Structure Fires
Reported to U.S. Fire Departments**

Extent of Flame Damage	Fires	Deaths
No flame damage	3 (0.0%)	0
Confined to object of origin	2,825 (43.1%)	0*
Confined to area of origin	972 (14.8%)	1
Confined to room of origin	1,191 (18.2%)	1
Confined to fire-rated compartment of origin	61 (0.9%)	0
Confined to floor of origin	245 (3.7%)	0
Confined to building of origin	1,041 (15.9%)	2
Extended beyond building of origin	210 (3.2%)	0
Total	6,548	4

Extent of Smoke Damage	Fires	Deaths
No smoke damage	883 (13.5%)	0*
Confined to object of origin	1,103 (16.8%)	0
Confined to area of origin	571 (8.7%)	0
Confined to room of origin	1,047 (16.0%)	0
Confined to fire-rated compartment of origin	64 (1.0%)	0
Confined to floor of origin	540 (8.2%)	0
Confined to building of origin	2,003 (30.6%)	2
Extended beyond building of origin	337 (5.1%)	1
Total	6,548	4

* Rounds to zero but is not zero

Fires with extent of damage unknown have been proportionally allocated. Sums may not equal totals because of rounding error.

**Table 8. General Office Building Fires, by Extent of Flame and Smoke
Fires Originating on a Level 10-19 Feet Above Grade
Annual Average of 1980-1989 Structure Fires
Reported to U.S. Fire Departments**

Extent of Flame Damage	Fires	Deaths
No flame damage	1 (0.1%)	0
Confined to object of origin	916 (47.7%)	0
Confined to area of origin	319 (16.6%)	0*
Confined to room of origin	285 (14.8%)	0*
Confined to fire-rated compartment of origin	15 (0.8%)	0
Confined to floor of origin	110 (5.7%)	1
Confined to building of origin	233 (12.1%)	0*
Extended beyond building of origin	40 (2.1%)	0
Total	1,920	2

Extent of Smoke Damage	Fires	Deaths
No smoke damage	333 (17.3%)	0*
Confined to object of origin	334 (17.4%)	0
Confined to area of origin	181 (9.4%)	0
Confined to room of origin	283 (14.7%)	0
Confined to fire-rated compartment of origin	27 (1.4%)	0
Confined to floor of origin	260 (13.5%)	1
Confined to building of origin	412 (21.5%)	1
Extended beyond building of origin	91 (4.7%)	0
Total	1,920	2

* Rounds to zero but is not zero

Fires with extent of damage unknown have been proportionally allocated. Sums may not equal totals because of rounding error.

**Table 9. General Office Building Fires, by Extent of Flame and Smoke
Fires Originating in the Building Above 19 Feet Above Grade
Annual Average of 1980-1989 Structure Fires
Reported to U.S. Fire Departments**

Extent of Flame Damage	Fires	Deaths
No flame damage	0 (0.0%)	0
Confined to object of origin	1,162 (57.4%)	0
Confined to area of origin	325 (16.0%)	0*
Confined to room of origin	301 (14.8%)	0
Confined to fire-rated compartment of origin	19 (0.9%)	0
Confined to floor of origin	92 (4.5%)	0*
Confined to building of origin	109 (5.4%)	1
Extended beyond building of origin	18 (0.9%)	0
Total	2,026	2

Extent of Smoke Damage	Fires	Deaths
No smoke damage	331 (16.3%)	0
Confined to object of origin	453 (22.4%)	0
Confined to area of origin	236 (11.6%)	0*
Confined to room of origin	320 (15.8%)	0
Confined to fire-rated compartment of origin	32 (1.6%)	0
Confined to floor of origin	294 (14.5%)	0
Confined to building of origin	311 (15.3%)	2
Extended beyond building of origin	49 (2.4%)	0
Total	2,026	2

* Not zero but rounds to zero

Fires with extent of damage unknown have been proportionally allocated. Sums may not equal totals because of rounding error.

ATTACHMENT TO APPENDIX A

The following published articles are referenced in Appendix A and were attached to the report submitted by Dr. Hall. Because of both bulk and potential copyright infringement, they are not reproduced in this report. All are available in the open literature and are in the collections of both the NFPA and NIST's Fire Research Information Service. The following citations are cross referenced to the FIDO Summary case numbers in Dr. Hall's report.

a. FIDO Case 1. Atlanta, Georgia

Isner, Michael S., "Five Die in High-Rise Office Building Fire", NFPA Fire Journal, July/August 1990, pp 51-59

b. FIDO Case 7. Los Angeles, California

Klem, Thomas J., "Los Angeles High-Rise Bank Fire, NFPA Fire Journal, May/June 1989, pp 73-91

Nelson, Harold E., Science in Action, An Engineering View of the Fire at the First Interstate Bank Building, NFPA Fire Journal, July/August 1989, pp 28-34

c. FIDO Case 9. Chicago, Illinois

Eisner, Harvey, "Controversial Communications, High-rise deaths leave two cities questioning emergency services", Firehouse, September 1987 pp 45-46 and 77-79

Appendix B

Analysis of Mass Flows and Contaminant Concentrations in Staging Areas

John H. Klote
Scot Deal
Building and Fire Research Laboratory
National Institute of Standards and Technology
Gaithersburg, MD 20899

TABLE OF CONTENTS

	Page
NOMENCLATURE	147
1. INTRODUCTION	148
2. FLOW AREAS	148
3. PRESSURIZATION SMOKE CONTROL SYSTEMS	149
3.1 Pressure Differences	149
3.2 Effect of Open Doors	150
3.3 Flow Analysis Using Network Computer Model	151
4. APPROACH FOR ANALYSIS OF SMOKE PROTECTION BY COMPARTMENTATION	152
5. MASS FLOW FOR COMPARTMENTATION ANALYSIS	153
5.1 Stack Effect Dominated Flow With Broken Fire Floor Window	154
5.2 Stack Effect Dominated Flow Without Broken Fire Floor Window	155
5.3 Buoyancy Dominated Flow Analysis	156
5.4 Buoyancy Dominated Flow with Pressurization	157
6. CONCENTRATIONS	159
6.1 General Concentration Equations	159
6.2 Dilution of a Space Without Smoke Infiltration	160
6.3 Only Steady Flow from the Fire Floor	161
6.4 Steady Flow from the Fire Floor Plus Supply Air	161
7. DISCUSSION OF THE EFFECT OF SUPPLY AND EXHAUST ON CONCENTRATION ..	162
7.1 Supply Air and No Exhaust	162
7.2 Supply and Exhaust Air at the Same Rate	162
7.3 Exhaust Air Less Than Supply Air	163
7.4 Supply Air Less Than Exhausted Air	163
7.5 Exhausted and No Supply	163
8. TIME VARYING FIRE FLOOR CONCENTRATIONS	163
9. TEMPERATURE	164
10. EVALUATION OF BIDIRECTIONAL FLOW	164
11. REFERENCES	166

Appendix B Analysis of Mass Flows and Contaminant Concentrations in Staging Areas

John H. Klote
Scot Deal
Building and Fire Research Laboratory
National Institute of Standards and Technology
Gaithersburg, MD 20899

NOMENCLATURE

A area, m² (ft²)
C flow coefficient, dimensionless
C_p specific heat, 0.001 J/kg K (0.24 Btu/lb °F)
c concentration, arbitrary dimensions
g acceleration of gravity, m/s² (ft/s²) [*g* is approximately 9.80 m/s² (32.2 ft/s²)]
H height above the bottom of space, m (ft)
H_n height of neutral plane above the bottom of space, m (ft)
h convective heat transfer coefficient, J/kg K m² (Btu/lb °R ft²)
K_o constant, 1.00 (12.9)
K_p constant, 1.00 (0.00598)
m mass flow rate, kg/s (lb/s)
p absolute pressure, Pa (in H₂O) [standard atmospheric pressure is 101,325 Pa (407.255 in H₂O)]
R gas constant, 287.0 J/kg K (10.27 in H₂O ft³ lb⁻¹ °R⁻¹)
T absolute temperature, K (°R)
t time, s (s)
W width of opening, m (ft)
 Δp pressure difference, Pa (in H₂O)
 Δt time interval, s (s)
 ρ density of air or smoke, kg/m³ (lb/ft³)
 λ concentration exponent, s⁻¹ (s⁻¹)

Subscripts

e effective
ex exhaust air
f fire floor
i into
o initial
out out

sstaging area
shshaft
susupply air
rtop
wallwall
∞outside

1. INTRODUCTION

The National Institute of Standards and Technology (NIST) is engaged in a project funded by the General Services Administration (GSA) to study the staging area concept. This appendix presents methods to estimate the mass flow and concentrations inside staging areas with and without pressurization. Information is also presented about the flow areas of leakage paths, which are important for smoke flow in buildings. Additionally, an overview of a method of determination of the threat within a staging area is presented.

2. FLOW AREAS

Some leakage paths, such as gaps around closed doors, are obvious. Construction cracks in building walls and floors are less obvious but important. The flow area of most large openings, such as open windows, can be calculated easily. However, flow areas of cracks are more difficult to evaluate. The area of these leakage paths is dependent on workmanship, for example how well a door is fitted or how well weather stripping is installed.

The leakage flow rates of door assemblies can be measured and rated at ambient temperature and elevated temperatures in accordance UL 1784 (1990). Information about the leakage through gaps around doors has been compiled by Gross and Haberman (1988). For doors that are not gasketed, the flow areas around closed doors can be approximated by the area of the gaps at the top and side plus the undercut of the door.

Typical leakage areas for walls and floors of commercial buildings are listed in table 1. These data are based on a relatively small number of tests performed by the National Research Council of Canada as referenced in the table. Actual leakage values are primarily dependent on workmanship rather than construction materials. Therefore, the flow areas in particular buildings will vary from the values listed. Considerable data concerning building components is also provided in Chapter 23 of the ASHRAE Handbook of Fundamentals (1989).

Flow areas of construction cracks and small gaps around gasketed doors can be estimated by the method of pressurization. This method is appropriate for determining the area of a large number of paths between two spaces. One space is pressurized by a known flow rate, m , of air, and the resulting pressure difference, Δp , from the space in question to another space is measured. This method is appropriate when all the air flows from the space in question to the other space. The flow area is

$$A = \frac{m}{CK_o\sqrt{2\rho\Delta p}} \quad (1)$$

For small cracks and gaps, the flow coefficient, C , is generally in the range of 0.6 to 0.7. In this paper a flow coefficient of 0.65 is used for these openings. Strictly speaking the density, ρ , is the density of air in the flow paths. However, this density generally is taken to be that in the pressurized space. In the discussion above, the space was pressurized, but it could have been exhausted. If the space is exhausted, then the density in equation (1) is that in the higher pressure space. The density is calculated by the ideal gas equation

$$\rho = \frac{p}{RT} \quad (2)$$

3. PRESSURIZATION SMOKE CONTROL SYSTEMS

Smoke control uses the barriers (walls, floors, doors, etc.) in conjunction with pressure differences produced by mechanical fans. A pressure difference across a barrier can control smoke movement, and figure 1 illustrates such a barrier with a door. The high pressure side of the door can be either a refuge area or an egress route. The low pressure side is exposed to smoke from a fire. Solving equation (2) for mass flow rate provides the commonly used relationship between flow and pressure difference

$$m = K_o CA \sqrt{2\rho\Delta p} \quad (3)$$

3.1 Pressure Differences

It is appropriate to consider both a maximum and a minimum allowable pressure difference across a barrier of a smoke control system. The values discussed in this section are based on the suggestions in the NFPA 92A (1988). The maximum allowable pressure difference should be a value that does not result in excessive door opening forces, although it is somewhat difficult to determine what constitutes excessive door opening forces. The force to open a door is the sum of the forces to overcome the door closer and to overcome the pressure difference across the door. Clearly, a person's physical condition is a major factor in determining a reasonable door opening force for that person. The Life Safety Code (NFPA 1991) states that the force required to open any door in a means of egress shall not exceed 30 lb (133N). For this limitation, maximum allowable pressure differences, calculated by the methods presented in the ASHRAE Smoke Control Manual, are listed in tables 2 and 3. It is possible that future codes may reduce

the allowable door opening force below 30 lb (133N), and the resulting allowable maximum allowable pressure differences would be reduced accordingly.

Caution should be exercised in evaluating door closer force, because the force produced by the closer when the door is closing is often different from the force required to overcome the closer when opening the door. Many door closers require less force in the initial portions of the opening cycle than they do to bring the door to the full open position. The door closer force in tables 2 and 3 is the force that the door closer exerts on the door at the very beginning of the opening cycle.

The method of design analysis for pressurization in the ASHRAE Smoke Control Manual and NFPA 92A directly incorporates the effects of wind and stack action, and the fire effect is indirectly incorporated by selection of the minimum design pressure difference. A smoke control system should be designed to maintain this minimum value under likely conditions of stack effect and wind and when there is no building fire (such as during acceptance or routine testing). Some suggested minimum design pressure differences are listed in table 4. The values for nonsprinklered spaces are those that will not be overcome by the buoyancy forces of hot gases.

These values were calculated for a gas temperature of 927°C (1700°F), for a height above the neutral plane* of 2/3 of the ceiling height, and with a safety factor of 7 Pa (0.03 in H₂O). If values are desired for other temperatures or ceiling heights, the calculation method presented in appendix A of NFPA 92A can be used.

Pressure differences produced by smoke control systems tend to fluctuate due to the wind, fan pulsations, doors opening, doors closing, and other factors. Short term deviations from the suggested minimum design pressure difference may not have a serious effect on the protection provided by a smoke control system. There is no clear cut allowable value of this deviation. It depends on tightness of doors, tightness of construction, toxicity of smoke, air flow rates, and on the volumes of the spaces. Intermittent deviations up to 50% of the suggested minimum design pressure difference are considered tolerable in most cases.

3.2 Effect of Open Doors

The effect of open doors in the barriers of smoke control systems must be considered. If doors are opened only for the short time needed for a person to escape a smoke contaminated space, the resulting small amount of smoke infiltrating into the protected area probably will not adversely affect the performance of the smoke control system. The potential danger of open doors is that opening and closing doors remote from the fire will result in unacceptable pressure fluctuations at smoke control barriers near the fire. The ASHRAE Smoke Control Manual discusses several approaches to mitigate these fluctuations for pressurized stairwells. These approaches are similar to smoke control systems for pressurized elevator lobbies presented by Klote and Tamura (1991), and similar approaches can be used for smoke control systems for staging areas that are directly connected to an elevator shaft or a stairwell.

*The concept of the neutral plane is discussed a the section about mass flow analysis.

Analysis of smoke control systems for staging areas connected to shafts is complex in that the flows and pressure differences at the barriers are linked to the flows throughout the rest of the building. The network approach discussed in the next section makes such analysis practical.

3.3 Flow Analysis Using Network Computer Model

Network flow analysis can be useful for evaluation of the flows and pressure differences produced by smoke control systems. Such an analysis can include stack effect, and the effects of wind and forced ventilation systems. For a review of network programs for analysis of smoke control, the reader is referred to Said (1988).

The network computer program described in this section is entitled Analysis of Smoke Control Systems (ASCOS). A detailed description of the computer program and example input and output are included in the ASHRAE smoke control manual (Klote and Fothergill 1983).

In this computer program, a building is represented by a network of spaces or nodes, each at a specific pressure and temperature. The stairwells and other shafts are modeled by a vertical series of spaces, one for each floor. Air flows through leakage paths from regions of high pressure to regions of low pressure. These leakage paths are doors and windows that may be opened or closed. Leakage can also occur through partitions, floors, exterior walls and roofs. The airflow through a leakage path is a function of the pressure difference across the leakage path.

In this model, air from outside the building can be introduced by a pressurization system into any level of a shaft or even into other building spaces. This allows simulation of stairwell pressurization, elevator shaft pressurization, stairwell vestibule pressurization, and pressurization of any other building space. In addition, any building space can be exhausted. This allows analysis of zoned smoke control systems where the fire zone is exhausted and other zones are pressurized. The pressures throughout the building and steady flow rates through all the flow paths are obtained by solving the airflow network, including the driving forces such as wind, the pressurization system, and inside-to-outside temperature difference.

The ASCOS program has the following assumptions and limitations:

1. Each space is considered to be at one specific pressure and one specific temperature.
2. The flows and leakage paths are assumed to occur at mid-height of each level.
3. The net air supplied by the air handling system or by the pressurization system is assumed to be constant and independent of building pressure.
4. The outside air temperature is assumed to be constant.
5. The barometric pressure at ground level is assumed to be standard atmospheric pressure, 101325 Pa (407.25 in H₂O).

The results of the program are not very sensitive to changes in atmospheric pressure. For altitudes considerably different from sea level, a more accurate value of barometric pressure can be substituted by

changing an assign statement in the program. ASCOS does not simulate bidirectional flow between compartments, but this limitation can be overcome by the method of evaluation of bidirectional flow at the end of this appendix.

4. APPROACH FOR ANALYSIS OF SMOKE PROTECTION BY COMPARTMENTATION

The approach presented here for evaluation of the threat within a staging area consists of calculating the following:

1. conditions on the fire floor in the vicinity of the staging area,
2. mass flow rates to and from the staging area,
3. gas concentrations within the staging area,
4. temperature within the staging area, and
5. tenability within the staging area.

FPETOOL (Nelson 1990) can be used to generate values of gas concentrations and temperatures for use in these analyses. This evaluation is based on one or more design fires. The evaluation of the fire floor conditions is not addressed in this paper, and these conditions are provided as a given to the example calculations.

The mass flow rate from the fire floor to the staging area can depend on the location of the fire floor and on the extent of openings from the building to the outside. Considerations relevant to the selection of design conditions for the flow calculations are discussed later. Once the flow conditions have been calculated, the temperatures and concentration inside the staging area can be determined, and the threat can be calculated.

The calculations presented in this paper are based on the idealization of perfect mixing in the staging area. That is, the properties (temperature, density etc.) and constituents (nitrogen, oxygen, carbon monoxide, etc.) are uniform throughout the staging area. It follows from this that mixing of flows into a space occurs instantly. The perfect mixing idealization is appropriate to the extent that gases in the space are well mixed due to the effect of a ventilation system, motion of any people within the space, room air currents due to convection patterns or stack effect, or other driving forces.

The approach presented here does not address the stratified smoke layer that frequently forms at the ceiling on the fire floor. Consideration of this layer is not necessary when smoke quickly fills the spaces adjacent to the staging area from a rapidly growing fire or from a sprinklered fire. The conditions of stratification have been modeled by considering room air and the smoke layer as two separate zones. Mitler and Emmons (1981) and Zukoski and Kubota (1980) have developed such zone models for room fires, and Tanaka (1983) and Jones (1984) have developed multiroom zone models. Mitler (1985) and Jones (1983) provide comparative information about many zone models.

Bukowski et al. (1989) combined a group of computer models for evaluation of hazard due to fires in residences which incorporates a zone model to simulate smoke transport and a tenability model to estimate the responses of occupants to toxicity and temperature.

5. MASS FLOW FOR COMPARTMENTATION ANALYSIS

The major driving forces of air and smoke movement in buildings are forced ventilation systems, wind, stack effect due to the indoor to outdoor temperature difference, and buoyancy of fire gases. Forced ventilation used to pressurize the staging area has already been discussed, and forced ventilation to dilute contaminants is addressed later.

Incorporation of wind in an analytical method of flow analysis introduces complexities that inhibit the development of equations that can be applied directly and used to provide insight. When windows are closed and there are no other large openings to the outside, it is believed that wind has only minor influence on smoke movement. However, wind can have a pronounced effect on smoke movement when there are large openings from the building to the outside. The methods of flow analysis that follow are for buildings with and without large openings to the outside in the absence of wind. The analysis with open windows is intended to provide understanding of the mechanisms involved. If wind effects are considered likely, a network flow analysis program such as ASCOS can be used to evaluate the flows due to wind and a number of other driving forces operating together.

Frequently when it is cold outside, there is an upward movement of air within building shafts, such as stairwells, elevator shafts, dumbwaiters shafts, mechanical shafts, and mail chutes. Air in the building has a buoyant force because it is warmer and therefore less dense than outside air. The buoyant force causes air to rise within building shafts. This phenomenon is called by various names such as stack effect, stack action, and chimney effect. These names come from the comparison with the upward flow of gases in a smoke stack or chimney. However, a downward flow of air can occur in air conditioned buildings when it is hot outside. For this paper, the upward flow will be called normal stack effect, and the downward flow will be called reverse stack effect as illustrated in figure 2 (a) and (b).

The neutral plane is a horizontal plane where the pressure inside equals that outside. The location of the neutral plane is of importance in mass flow calculations due to stack effect and buoyancy. If the leakage of the shaft and the building is uniformly distributed with elevation, the neutral plane between a shaft and the outside is located approximately at the mid height of the shaft. In many situations this approximation results in an acceptable estimate of the location of the neutral plane. For shafts with open doors, open vents or other nonuniform flow paths, the neutral plane can be located far from the mid height. These cases require detailed analysis. The general computer routine by Klote (1991) can be used for evaluation of stack effect under any conditions of leakage paths.

For conservative analyses, the fire floor location needs to be selected so that the pressure difference from the fire floor to the staging area is the largest. The pressure difference due to stack effect is proportional to the distance from the neutral plane. The direction of the pressure difference is from the fire floor to the staging area for floors below the neutral plane during normal stack effect. For reverse stack effect, this direction occurs above the neutral plane. Therefore, the extreme locations of the fire floor are the lowest floor during normal stack effect, and the upper most floor during reverse stack effect. In most locations in the United States, the temperature differences between the outdoor and indoor are greater for

winter than summer design conditions. Thus the extreme location of the fire floor for normal stack effect as illustrated in figure 2(c) is used for the following analyses in this paper. For the few locations where reverse stack effect is greater, the analysis below can be modified accordingly.

It can be shown that, for the staging area leakages and temperatures discussed in this paper, bidirectional flow between the staging area and the fire floor will not exist when stack effect is dominant. Additionally, when the flow through a path is unidirectional, evaluation of the flow at the midheight of the path is an acceptable approximation for the purposes of this paper. The analyses of dominant stack effect that follow are based on these simplifications.

In addition to flow analysis for dominant stack effect with and without open windows, the following methods include mass flow where the dominant driving force is buoyancy. In all the following analyses, the leakage paths are taken to be uniform over the height of the floor. This means that the leakage paths can be approximated by floor to ceiling openings of constant width. In reality the leakage paths are not so uniform. The location and area of a specific opening is extremely difficult to determine. Based on engineering judgement, the gaps around doors are considered to account for 30 to 60% of the leakage areas in most building partitions. Buoyancy pressure is greater near the ceiling, and in many situations there are less openings near the ceiling than at other elevations. To the extent that there are less openings near the ceiling, the constant width approximation yields conservative results concerning estimation of smoke infiltration to the staging area. For unusually large openings near the ceiling, the infiltration into the staging area must be adjusted.

5.1 Stack Effect Dominated Flow With Broken Fire Floor Window

The design conditions for this analysis are:

1. The analysis is for steady flows.
2. The most severe floor for analysis is the lowest floor in the building with a staging area.
3. A large window has broken open on the fire floor.
4. The mass flows are dominated by normal stack effect. (Thus the outside air temperature is less than the building temperature.)
5. The temperature of the gases on the fire floor is much greater than that in other parts of the building.
6. There is no pressurization or smoke exhaust of the staging area.

For the conditions above, the resulting flows are illustrated in figure 3(a) and figure 4. From the law of conservation of mass, the mass flow rate into the staging area equals that leaving it:

$$m_{f,s} = m_{s,sh} \quad (4)$$

In this and the following equations, the subscripts of mass flow indicate the direction of that flow. For example $m_{f,s}$ is from the fire floor to the staging area. The mass flow rate from the fire floor to the staging area can be expressed by an equation of the same form as equation (3).

$$m_{f,s} = K_o C A_{f,s} \sqrt{2 \rho_f \Delta P_{f,s}} \quad (5)$$

Using the concept of effective flow area, this mass flow rate is

$$m_{f,s} = K_o C A_e \sqrt{2 \rho_{sh} \Delta P_{\infty,sh}} \quad (6)$$

where A_e is the effective flow area from the outside through the fire floor and staging area to the shaft. The effective area of a system of flow areas is the area that results in the same flow as the system when it is subjected to the same pressure difference over the total system of flow paths. The concept of effective flow area is described in detail in the ASHRAE Smoke Control Manual. Considering the flow area of the broken window to be much greater than the other flow areas, the effective flow area above is

$$A_e = T_{sh}^{1/2} \left(\frac{T_f}{A_{f,s}^2} + \frac{T_s}{A_{s,sh}^2} \right)^{-1/2} \quad (7)$$

The pressure difference, $\Delta p_{\infty,sh}$, is due to stack effect and is expressed as

$$\Delta P_{\infty,sh} = \frac{K_p g p H n_{sh,\infty}}{R} \left(\frac{1}{T_\infty} - \frac{1}{T_{sh}} \right) \quad (8)$$

5.2 Stack Effect Dominated Flow Without Broken Fire Floor Window

The design conditions for this analysis are:

1. The analysis is for steady flows.
2. The most severe floor for analysis is the lowest floor in the building with a staging area.
3. The mass flows are dominated by normal stack effect. (Thus the outside air temperature is less than the building temperature.)
4. There is no pressurization or smoke exhaust of the staging area.
5. The leakage between the fire floor and the outside is the same as the leakage between other floors and the outside. (The fire floor windows are intact.)

Not having a broken window or other large opening on the fire floor reduces the pressure difference across the staging area walls. This reduced pressure difference reduces the mass flow of gases from the fire floor to the staging area as illustrated in figure 3(a) and (b). The mass flow from the fire floor to the staging area is given by equation (6) where the effective flow area is

$$A_e = T_{sh}^{1/2} \left(\frac{T_\infty}{A_{\infty,f}^2} + \frac{T_f}{A_{f,s}^2} + \frac{T_s}{A_{s,sf}^2} \right)^{-1/2} \quad (9)$$

The above discussion of the pressure difference, $\Delta p_{\infty,sh}$, and of the location of the neutral plane also applies to this analysis.

5.3 Buoyancy Dominated Flow Analysis

The design conditions for this analysis are:

1. The analysis is for steady flows.
2. The mass flows are dominated by buoyancy forces of fire gases.
3. There is no pressurization or smoke exhaust of the staging area.
4. A plane of neutral pressure exists between the fire floor and the staging area.

The pressure difference and flows between fire floor and the staging area are illustrated in figure 5. The conservation of mass equation for the staging area is

$$m_{f,s} = m_{s,\infty} + m_{s,f} \quad (10)$$

The pressure difference from the fire floor to the staging area can be expressed as

$$\Delta p_{f,s} = p_f - p_s = K_p g z (\rho_s - \rho_f) \quad (11)$$

The mass flow rate from the fire floor to the staging area for a differential element of height dz is

$$dm_{f,s} = K_o C W_{f,s} \sqrt{2 \rho_f \Delta p_{f,s}} dz = K_o C W_{f,s} \sqrt{2 g \rho_f z K_p (\rho_s - \rho_f)} dz \quad (12)$$

Integrating this equation from $z = H_{n,s,f}$ to $z = H_f$ and considering the width, $W_{f,s}$, of the leakage path constant yields

$$m_{f,s} = \frac{2}{3} K_o C W_{s,f} (H_f - H_{n,s,f})^{3/2} \sqrt{2 g \rho_f K_p (\rho_s - \rho_f)} \quad (13)$$

For a staging area only connected to the fire floor, the location of the neutral plane is given by equation (10) by Klote (1991). In the notation of this context, this becomes

$$\frac{H_{n,s,f}}{H_f} = \frac{1}{1 + (T_f/T_s)^{1/3}} \quad (14)$$

For staging areas connected to the outside or to parts of the building away from the fire, there is no simple way of determining the location of the neutral plane between the staging area and the fire floor. For this situation, the conservative approach is to select the neutral plane at the floor. The flow from the fire floor to the staging area with the neutral plane at the floor is

$$m_{f,s} = \frac{2}{3} K_o C W_{s,f} H_f^{3/2} \sqrt{2 g \rho_f K_p (\rho_s - \rho_f)} \quad (15)$$

5.4 Buoyancy Dominated Flow with Pressurization

The design conditions for this analysis are:

1. The analysis is for steady flows.
2. The mass flows are dominated by buoyancy forces of fire gases.
3. There is pressurization of the staging area.
4. A plane of neutral pressure exists between the fire floor and the staging area.

The pressure differences and flows for the staging areas are illustrated in figure 6(a). The amount of pressurization determines the location of the neutral plane between the staging area and the fire floor. As

the flow rate of pressurization air increases, the height of the neutral plane increases. When the neutral plane is located at the ceiling of the fire floor, there is no flow from the fire floor into the staging area as illustrated in figure 6(b). This critical flow of pressurization air is given by

$$(m_{su})_{crit} = \frac{2}{3} K_o C W_{s,f} H_f^{3/2} \sqrt{2g \rho_s K_p (\rho_s - \rho_f)} \quad (16)$$

If the flow of pressurization air is equal to or greater than this critical value, there will not be smoke infiltration into the staging area. The analysis in this section is for pressurization below the critical value resulting in some smoke infiltration.

The conservation of mass equation for the staging area is

$$m_{su} + m_{f,s} - m_{s,f} = 0 \quad (17)$$

The flow rate, $m_{f,s}$, from the fire floor to the staging area is given by equation (13), and flow rate from the staging area to the fire floor is

$$m_{s,f} = \frac{2}{3} K_o C W_{s,f} H n_{s,f}^{3/2} \sqrt{2g \rho_s K_p (\rho_s - \rho_f)} \quad (18)$$

Substituting these flow equations into the conservation of mass equation and simplifying results in the following expression

$$\frac{m_{su}}{(m_{su})_{crit}} = \left(\frac{H n_{s,f}}{H_f} \right)^{3/2} - \left(\frac{T_s}{T_f} \right)^{1/2} \left(1 - \frac{H n_{s,f}}{H_f} \right)^{3/2} \quad (19)$$

This equation is shown in figure 7 for T_s/T_f of 0.294. The negative values of $m_{su}/(m_{su})_{crit}$ represent air exhausted from the staging area. At the neutral plane location of $H n_{s,f}/H_f = 0.399$, the curve of figure 7 shows that the flow of pressurization air is zero. This is the same location of neutral plane predicted by equation (14) for T_s/T_f of 0.294. This is expected since equation (14) is appropriate when there is no pressurization or exhaust from the staging area. In fact when there is no pressurization air ($m_{su} = 0$), the equation (19) reduces to equation (14).

6. CONCENTRATIONS

6.1 General Concentration Equations

This section presents methods of analysis of the concentrations of contaminants and the depletion of oxygen in spaces remote from a fire. In general a space can have any number of flows entering and leaving. The analyses of concentrations are based on the idealization of perfect mixing. Further, the properties of a mixture of air and fire gases are nearly the same as those of air. This analysis considers these properties independent of the composition of the gases.

For steady flow the conservation of mass equation is

$$\left(\sum_{i=1}^n m_i \right)_{in} = \left(\sum_{j=1}^k m_j \right)_{out} \quad (20)$$

The conservation of contaminant in the staging area is given by the following general equation

$$\left[\left(\sum_{i=1}^n m_i c_i \right)_{in} - \left(\sum_{j=1}^k m_j c_s \right)_{out} \right] dt = V_s \rho_s dc_s \quad (21)$$

where n is the number of mass flows entering the staging area and k is the number of mass flows leaving the area. This equation is applicable to concentrations of component gases when changes in these concentrations do not result in any significant changes in the properties of the mixture of the gases. Thus this equation is a good description of such major components as oxygen, carbon dioxide and carbon monoxide. Any units of concentration can be used provided that they are consistent (for example ppm, ppb, percent mass, percent volume). For constant concentrations, c_i , the solution of the above differential equation is

$$c_s = \frac{(m c)_{in}}{(m)_{out}} + \left(c_{s,o} - \frac{(m c)_{in}}{(m)_{out}} \right) e^{-\lambda t} \quad (22)$$

where

$$\begin{aligned}
(m)_{in} &= \left(\sum_{i=1}^n m_i \right)_{in} \\
(m)_{out} &= \left(\sum_{j=1}^k m_j \right)_{out} \\
(mC)_{in} &= \left(\sum_{i=1}^n m_i c_i \right)_{in} \\
(mC)_{out} &= \left(\sum_{j=1}^k m_j c_s \right)_{out} \\
\lambda &= \frac{(m)_{out}}{V_s \rho_s}
\end{aligned}$$

Substituting the steady flow conservation of mass equation into the above equation results in an expression for concentrations in terms of only the mass flows and concentrations entering the space.

$$c_s = \frac{(mC)_{in}}{(m)_{in}} + \left(c_{s,o} - \frac{(mC)_{in}}{(m)_{in}} \right) e^{-\lambda t} \quad (23)$$

where

$$\lambda = \frac{(m)_{in}}{V_s \rho_s}$$

This equation shows that for steady flows, concentration in a space is a function of the flows into the space, the initial concentration of that space, and the concentrations of those flows. It is not a function of the flows from that space. Two applications of the concentration equation are presented in the following sections.

6.2 Dilution of a Space Without Smoke Infiltration

For a space with an initial concentration of $c_{s,o}$ and pressurized by a flow of m_{su} , equation (23) becomes

$$c_s = c_{s,0} e^{-\lambda t} \quad (24)$$

where

$$\lambda = \frac{m_{su}}{V_s \rho_s}$$

6.3 Only Steady Flow from the Fire Floor

When the only flow into the staging area is m_{fs} at concentration c_f , the above equations reduce to:

$$c_s = c_f + (c_{s,0} - c_f) e^{-\lambda t} \quad (25)$$

where

$$\lambda = \frac{m_{fs}}{V_s \rho_s} \quad (26)$$

For contaminants that normally have minute concentrations in air, the initial concentration, $c_{s,0}$, is often taken to be zero. For an initial concentration of contaminant in the staging area of zero the above concentration equation becomes

$$c_s = c_f(1 - e^{-\lambda t}) \quad (27)$$

6.4 Steady Flow from the Fire Floor Plus Supply Air

Air is supplied to the staging area at a rate of m_{su} at a concentration of zero, the only other flow into the staging area is m_{fs} at concentration c_f , and the initial concentration, $c_{s,0}$, is zero. Equation (23) becomes

$$c_s = \frac{m_{f,s} c_f}{m_{f,s} + m_{su}} (1 - e^{-\lambda t}) \quad (28)$$

where

$$\lambda = \frac{m_{f,s} + m_{su}}{V_s \rho_s} \quad (29)$$

This concentration is less than it is without supply or exhaust. The maximum concentration without supply or exhaust is c_f [equation (10)], and the maximum concentration with supply is $(m_{f,s} c_f)/(m_{f,s} + m_{su})$. If $m_{f,s}$ were the same, the maximum concentration would be less when air is supplied to the staging area. When air is supplied to the staging area, the exponent, λ , is greater by a factor of $(m_{f,s} + m_{su})/m_{f,s}$. This increased exponent means that the staging area approaches its maximum concentration more slowly when air is supplied.

7. DISCUSSION OF THE EFFECT OF SUPPLY AND EXHAUST ON CONCENTRATION

The following conditions of supply and exhaust have significant effects on contaminant concentrations in staging areas:

1. Air flow supplied to the staging area, and no air exhausted from it.
2. Air flow supplied to the staging area, and the same mass flow rate of air exhausted from it.
3. Air flow supplied to the staging area, and a lesser mass flow rate of air exhausted from it.
4. Air flow supplied to the staging area, and a greater mass flow rate of air exhausted from it.
5. Air flow exhausted from the staging area, and no air supplied to it.

7.1 Supply Air and No Exhaust

The supply air increases the pressure within the staging area which reduces or eliminates the mass flow, $m_{f,s}$, from the fire floor to the staging area. This further reduces the concentration within the staging area. Thus supplying air to the staging area without any exhaust air has the potential to significantly reduce concentrations in the staging area.

7.2 Supply and Exhaust Air at the Same Rate

For air supplied at the same rate as it is exhausted ($m_{su} = m_{ex}$), the concentration in the staging area is expressed by equations (23) and (24). Because the supply and exhaust rates are the same, the methods of analysis presented above for cases without supply and exhaust can be used. The pressure in the staging area is the same as if there were no supply or exhaust. Thus the mass flow rate, $m_{f,s}$, into the staging area from the fire floor is the same as if there were no supply and exhaust. Thus the concentration is reduced due to dilution but not due to reduced infiltration.

7.3 Exhaust Air Less Than Supply Air

For exhaust air less than supply air ($m_{ex} < m_{su}$), the concentration in the staging area is expressed by equations (23) and (24). The pressure in the staging area is greater than it would be without any exhaust or supply, but not as great as with supply only.

7.4 Supply Air Less Than Exhausted Air

For supply air less than exhausted air ($m_{su} < m_{ex}$), the concentration in the staging area is also expressed by equations (23) and (24). The pressure in the staging area is less than it would be without any exhaust or supply. This results in increased infiltration into the staging area which tends to counter the effects of dilution.

7.5 Exhausted and No Supply

This approach is the least effective with regard to reducing contaminants in the staging area, and it is included only for completeness. For an exhausted staging area without any supply air, the concentration of contaminants is given by equations (9) and (10). The exhaust air results in decreased pressure in the staging area, and the infiltration flow rate, $m_{f,s}$, is increased. Other things being equal, this approach results in the highest levels of contaminants in the staging area.

8. TIME VARYING FIRE FLOOR CONCENTRATIONS

The analyses to the point has been based on constant concentrations, c_p , on the fire floor. For steady mass flow and perfect mixing, the explicit numerical solution to equation (20) developed by Wakamatsu (1977) is

$$c'_s = \frac{(mc)_{in}}{(m)_{out}} + \left(c_s - \frac{(mc)_{in}}{(m)_{out}} \right) \exp \left(- \frac{(m)_{out}}{V_s \rho_s} \Delta t \right) \quad (30)$$

In this equation c_s is the concentration in the staging area at time t , c'_s is the concentration in that space at time $t + \Delta t$, and Δc_s is the change in concentration in the time interval Δt for the staging area. Thus

the concentration in the staging area at time $t + \Delta t$ is expressed in terms of the concentration, c_s and c_i , at time t . Equation (30) is applicable to steady and unsteady flow. If the flow is steady, the flow terms out of the staging area can be replaced to give the following

$$c'_s = \frac{(mc)_{in}}{(m)_{in}} + \left(c_s - \frac{(mc)_{in}}{(m)_{in}} \right) \exp\left(-\frac{(m)_{in}}{V_s \rho_s} \Delta t \right) \quad (31)$$

9. TEMPERATURE

The temperature in the staging area can be calculated in a manner similar to that of the concentrations. The following temperature equation was derived from the conservation of energy equation by Wakamatsu (1977)

$$T'_s = T_s \left[1 - \frac{(m)_{out} \Delta t}{V_s \rho_s} \right] + \frac{\Delta t}{V_s \rho_s} \left[(mT)_{in} - \frac{(Ah \Delta T)_{wall}}{C_p} \right] \quad (32)$$

where

$$(mT)_{in} = \left(\sum_{i=1}^n m_i T_i \right)_{in}$$

$$(Ah \Delta T)_{wall} = \left[\sum_{w=1}^{n_{wall}} A_w h_w (T_s - T_w) \right]_{wall}$$

In this equation T_s is the temperature of the gases in the staging area at time t , and T'_s is that temperature at time $t + \Delta t$. Equation (32) includes convective heat transfer to the walls of the staging area.

10. EVALUATION OF BIDIRECTIONAL FLOW

When the net flow between two compartments of uniform temperature is known, the flow in both directions can be obtained. The net flow can be written as

$$m_{net} = m_{s,f} - m_{f,s} \quad (33)$$

Substituting equations (13) and (18) into equation (33) and rearranging yields:

$$m^* = (T^*)^{-1/2} (H^*)^{3/2} - (1 - H^*)^{3/2} \quad (34)$$

where

$$m^* = \frac{m_{net}}{(m_{f,s})_{crit}}$$

$$T^* = \frac{T_s}{T_f}$$

$$H^* = \frac{Hn_{s,f}}{H_f}$$

and where

$$(m_{su})_{crit} = \frac{2}{3} K_o C W_{s,f} H_f^{3/2} \sqrt{2g \rho_s K_p (\rho_s - \rho_f)} \quad (35)$$

Equation (35) is for the critical flow from the fire floor to the staging area where the neutral plane is at the floor of the staging area. The flow for other locations of the neutral plane is expressed as

$$m_{f,s} = (1 - H^*)^{3/2} (m_{f,s})_{crit} \quad (36)$$

Equations (34) to (36) are useful for evaluating bidirectional flows when the net flow has been calculated by ASCOS. The above equations are graphed in figure 8, and this figure can be used in place of a trial and error solution of equation (34).

11. REFERENCES

- ASHRAE Handbook - 1989 Fundamentals, American Society of Heating, Refrigerating and Air-Conditioning Engineers, Atlanta, GA.
- Bukowski, R.W., Peacock, R.D., Jones, W.W. and Forney, C.L. 1989. Chapter 7. Tenability Limits, Technical Reference Guide for the HAZARD I Fire Hazard Assessment Method, NIST Handbook 146, Vol II.
- Gross, D. and Haberman, W.L. 1988. Analysis and Prediction of Air Leakage through Door Assemblies, Fire Safety Science, Proceedings of the 2nd International Symposium, Tokyo, Japan, pp 169-178.
- Jones, W.W. 1983. A Review of Compartment Fire Models, Nat. Bur. of Stand. (U.S.), NBSIR 83-2684.
- Jones, W.W. 1984. A model for the transport of fire, smoke and toxic gases (FAST), Nat. Bur. of Stand. (U.S.), NBSIR 84-2934.
- Klote, J.H. and Fothergill, J.W. 1983. Design of Smoke Control Systems for Buildings, American Society of Heating, Refrigerating and Air-conditioning Engineers, Atlanta, GA.
- Klote, J.H. and Tamura, G.T. 1991. Design of Elevator Smoke Control Systems for Fire Evacuation, ASHRAE Transactions, Vol 99, Part 1.
- Klote, J.H. 1991. A General Routine for Analysis of Stack Effect, National Institute of Standards and Technology, NISTIR 4588.
- Mitler, H.E. 1985. Comparison of Several Compartment Fire Models: An Interim Report, Nat. Bur. of Stand. (U.S.), NBSIR 85-3233.
- Mitler, H.E. and Emmons, H.W. 1981. Documentation for CFC V, the fifth Harvard computer code. Home Fire Project Tech. Rep. #45, Harvard University.
- Nelson, H.E. 1990. FPETOOL: Fire Protection Tools for Hazard Estimation, National Institute of Standards and Technology, NISTIR 4380.
- NFPA 1988. Recommended Practice for Smoke Control Systems, NFPA 92A, Quincy, MA, National Fire Protection Assn.
- NFPA 1991. Code for Safety to Life from Fire in Buildings and Structures, NFPA 101-1991, Quincy, MA, National Fire Protection Assn.
- Said, M.N.A. 1988. A Review of Smoke Control Models, ASHRAE Journal, Vol 30, No 4, pp 36-40.
- Tamura, G.T. and Shaw, C.Y. 1978. Experimental Studies of Mechanical Venting for Smoke Control in Tall Office Buildings, ASHRAE Transactions, Vol. 86, Part 1, pp. 54-71.

Tamura, G.T. and Shaw, C.Y. 1976b. Air Leakage Data for the Design of Elevator and Stair Shaft Pressurization Systems, ASHRAE Transactions, Vol. 82, Part 2, pp. 179-190.

Tamura, G.T. and Shaw, C.Y. 1976a. Studies on Exterior Wall Air Tightness and Air Infiltration of Tall Buildings, ASHRAE Transactions, Vol. 82, Part 1, pp. 122-134.

Tamura, G.T. and Wilson, A.G. 1966. Pressure Differences for a Nine-Story Building as a Result of Chimney Effect and Ventilation System Operation, ASHRAE Transactions, Vol 72, Part 1, pp 180-189.

Tanaka, T. 1983. A Model of Multiroom Fire Spread. Nat. Bur. of Stand. (U.S.), NBSIR 83-2718.

Underwriters Laboratories 1990. Standard for Air Leakage Tests of Door Assemblies - UL 1784, Northbrook, IL.

Wakamatsu, T. 1977. Calculation Methods for Predicting Smoke Movement in Building Fires and Designing Smoke Control Systems, Fire Standards and Safety, ASTM STP-614, A.F. Robertson, Ed., Philadelphia, PA, American Society for Testing and Materials, pp 168-193.

Zukoski, E.E. and Kubota, T. 1980. Two-layer modeling of smoke movement in building fires, Fire and Materials, Vol 4, No 17.

Table 1 Typical leakage areas of for walls and floors of commercial buildings

Construction Element	Tightness	Area Ratio ¹
Exterior Building Walls (includes construction cracks, cracks around windows and doors)	Tight ²	0.7×10^{-4}
	Average ²	0.21×10^{-3}
	Loose ²	0.42×10^{-3}
	Very Loose ³	0.13×10^{-2}
Stairwell Wall (includes construction cracks but not cracks around windows or doors)	Tight ⁴	0.14×10^{-4}
	Average ⁴	0.11×10^{-3}
	Loose ⁴	0.35×10^{-3}
Elevator Shaft Walls (includes construction cracks but not cracks around doors)	Tight ⁴	0.18×10^{-3}
	Average ⁴	0.84×10^{-3}
	Loose ⁴	0.18×10^{-2}
Floors (includes construction cracks and gaps around penetrations)	Tight ⁵	0.66×10^{-5}
	Average ⁶	0.52×10^{-4}
	Loose ⁵	0.17×10^{-3}
¹ For a wall the area ratio is the area of the leakage through the wall divided by the total wall area. For a floor the area ratio is the area of the leakage through the floor divided by the total area of the floor. ² Values based measurements of Tamura and Shaw (1976a). ³ Values based measurements of Tamura and Wilson (1966). ⁴ Values based measurements of Tamura and Shaw (1976b). ⁵ Values extrapolated from average floor tightness based on range of tightness of other construction elements. ⁶ Values based measurements of Tamura and Shaw (1978).		

Table 2. Maximum allowable pressure differences across doors in pascals

Door Closer Force (N)	Door Width (m)				
	0.813	0.914	1.02	1.12	1.17
26.7	112	99.5	92.1	84.6	77.1
35.6	102	92.1	84.6	77.1	69.7
44.5	92.1	84.6	74.6	69.7	64.7
53.4	84.6	74.6	67.2	62.2	57.2
62.3	74.6	67.2	59.7	54.7	52.2

Notes:

1. Total door opening force is 133 N.
2. Door height is 2.13 m.

Table 3. Maximum allowable pressure differences across doors in inches of water

Door Closer Force (lb)	Door Width (inches)				
	32	36	40	44	46
6	0.45	0.40	0.37	0.34	0.31
8	0.41	0.37	0.34	0.31	0.28
10	0.37	0.34	0.30	0.28	0.26
12	0.34	0.30	0.27	0.25	0.23
14	0.30	0.27	0.24	0.22	0.21

Notes:

1. Total door opening force is 30 lb.
2. Door height is 7 ft.

Table 4. Suggested minimum pressure design difference across smoke barriers¹

Building Type ²	Ceiling Height		Design Pressure Difference	
	m	ft	Pa	inch H ₂ O
AS	Any	Any	12.4	0.05
NS	2.74	9	24.9	0.10
NS	4.57	15	34.8	0.14
NS	6.40	21	44.8	0.18

¹For design purposes, a smoke control system should maintain these minimum pressure differences under likely conditions of stack effect or wind.

²AS for sprinklered building, and NS for nonsprinklered building.

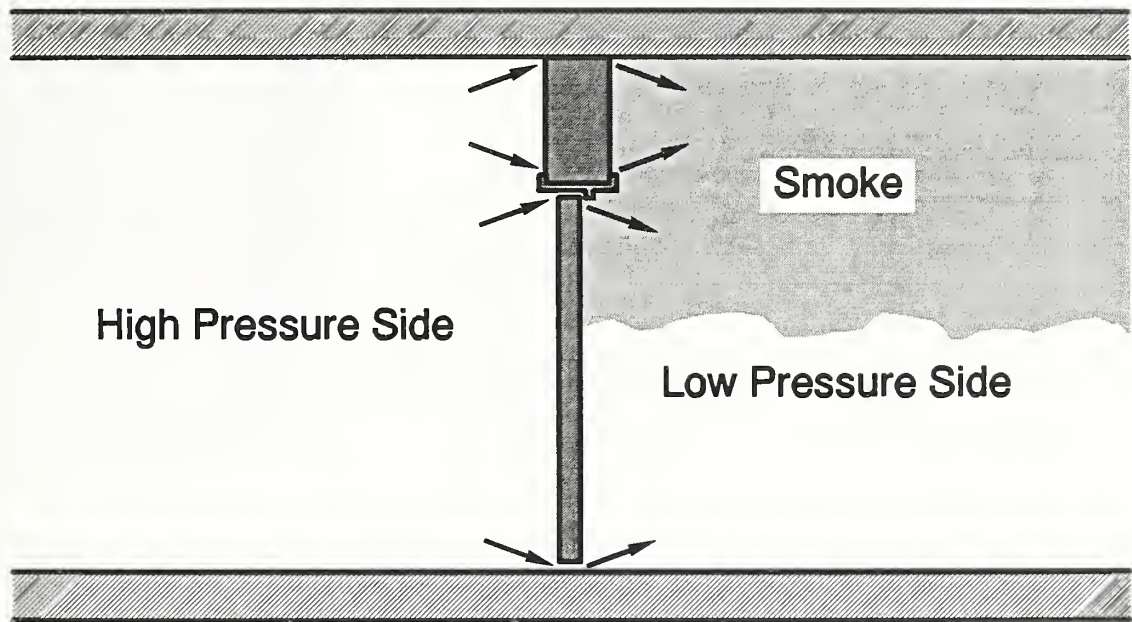

Figure 1. Pressure difference across a barrier of a smoke control system preventing smoke infiltration to the high pressure side of the barrier

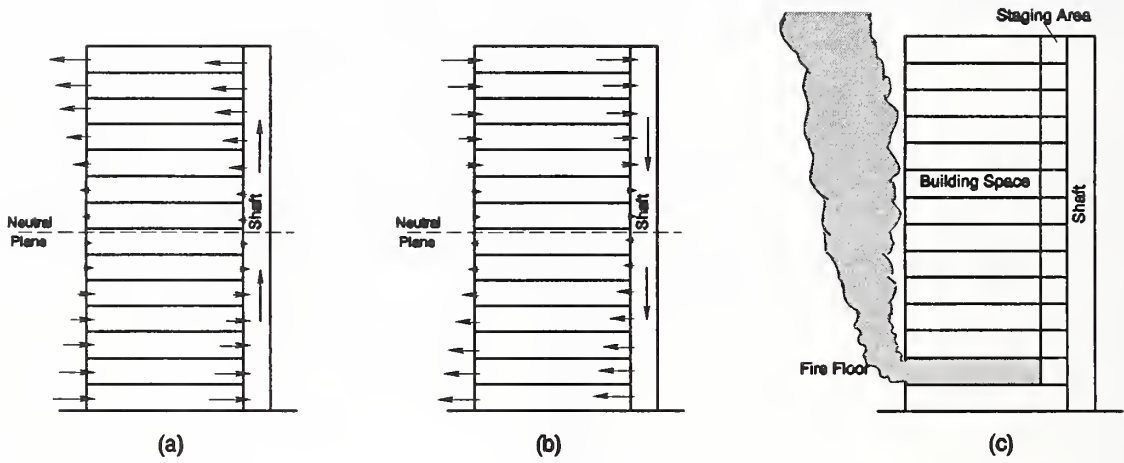
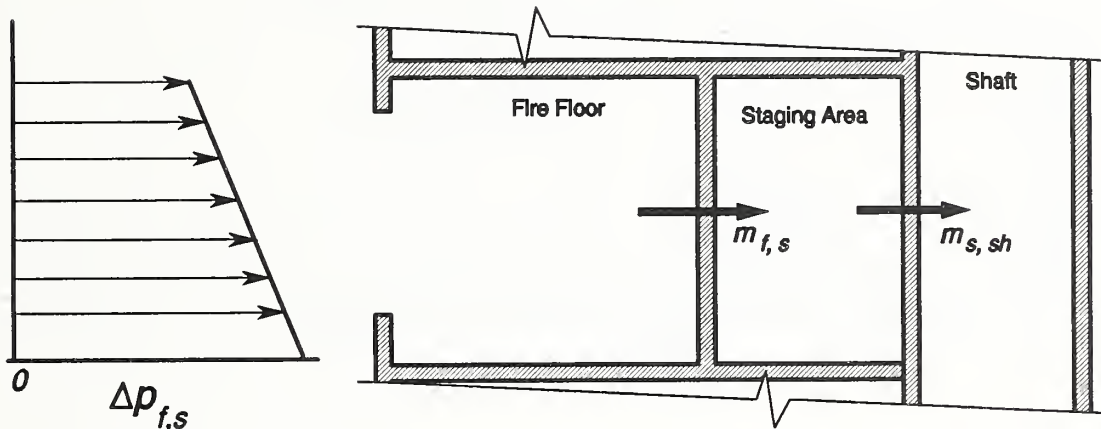
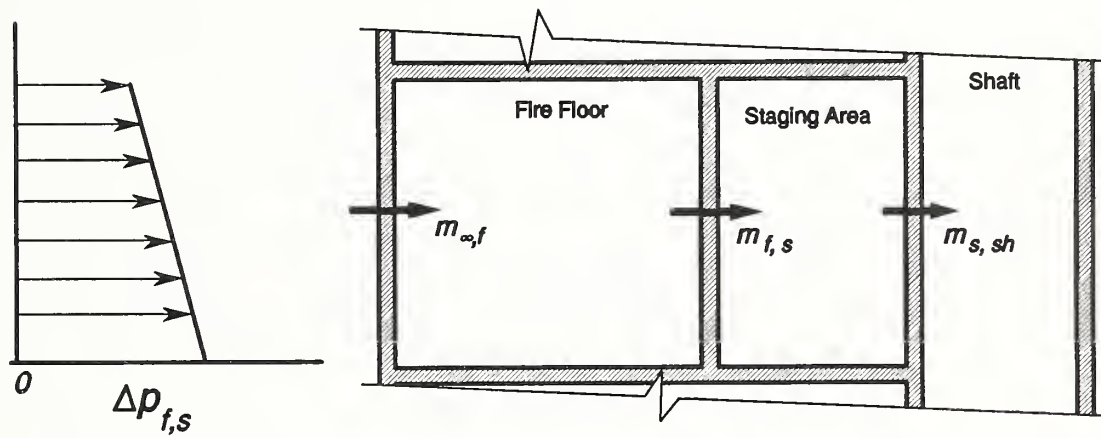

Figure 2. Stack effect and fire floor level location: (a) flows due to normal stack effect, (b) flows due to reverse stack effect, and (c) design location of the fire floor for dominant stack effect



(a) With Open Fire Floor Window



(b) Without Open Fire Floor Window

Figure 3. Staging areas connected to shafts

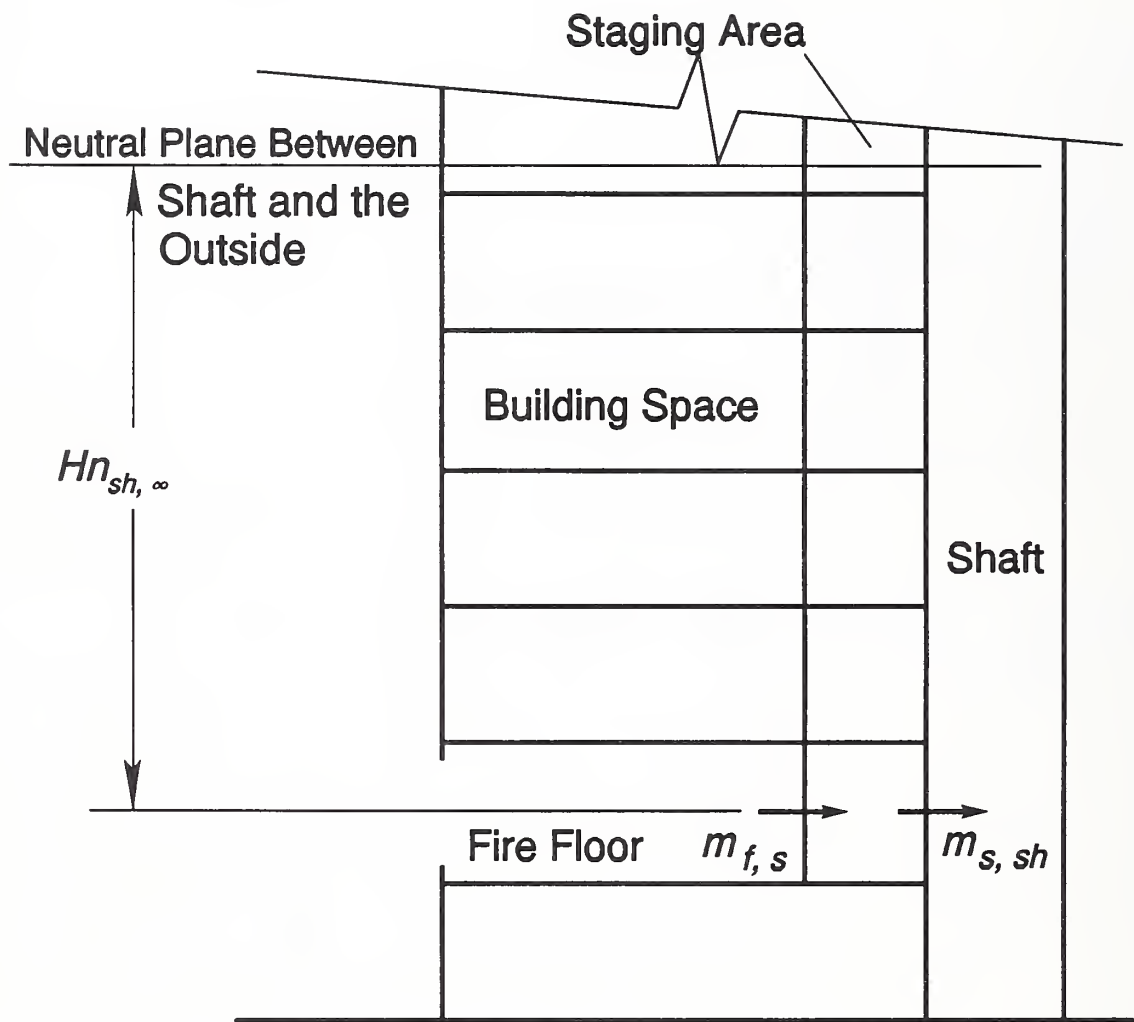

Figure 4. Stack effect dominated flow with broken fire floor window

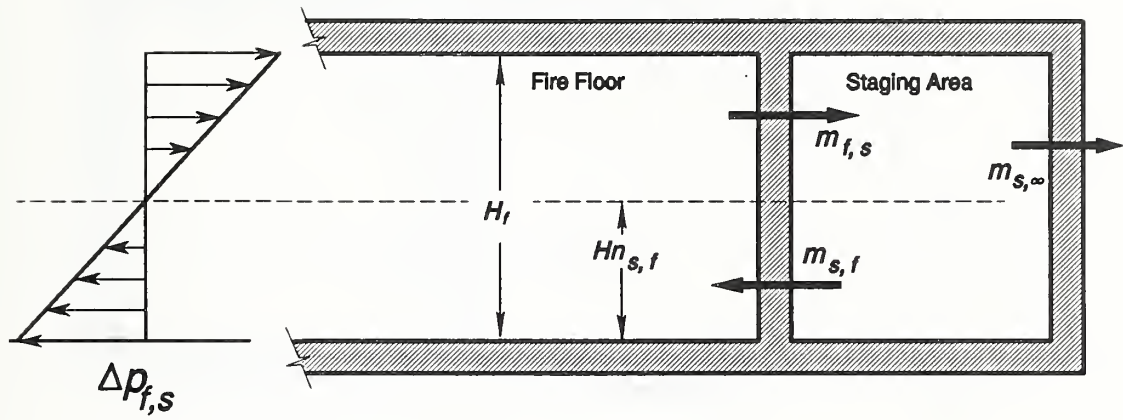
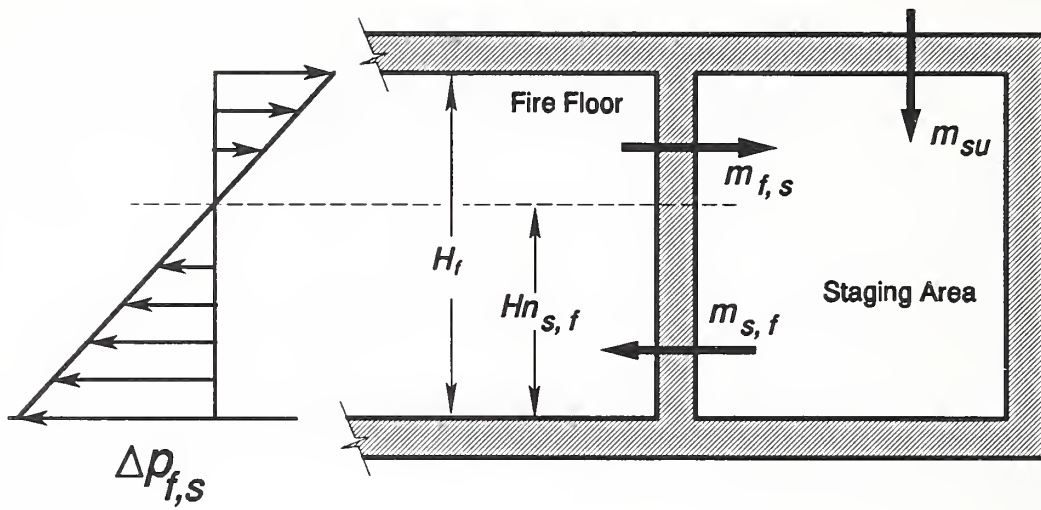
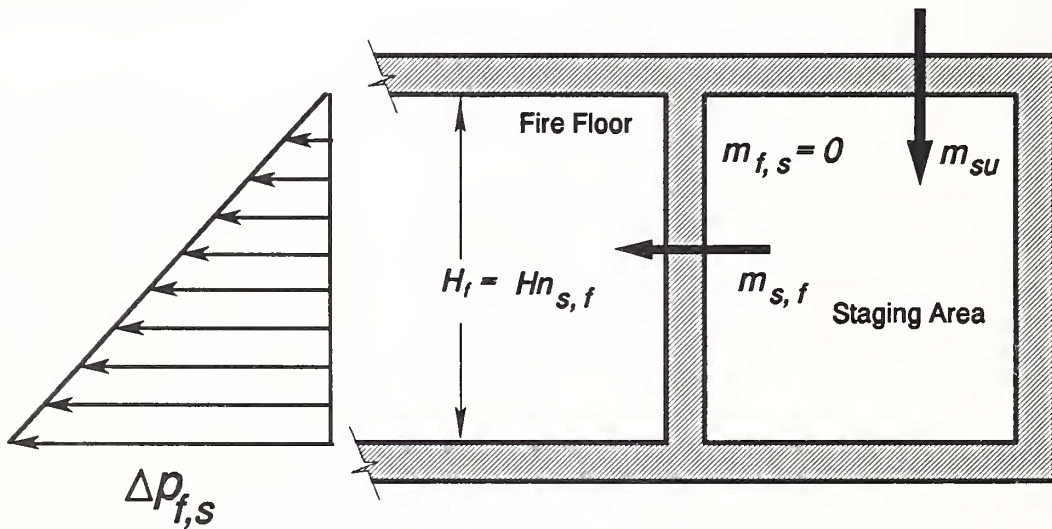

Figure 5. Staging area not connected to a shaft



(a) Pressurization Insufficient to Prevent Smoke Infiltration



(b) Pressurization Just Sufficient to Prevent Smoke Infiltration

Figure 6. Pressurized staging area not connected to a shaft

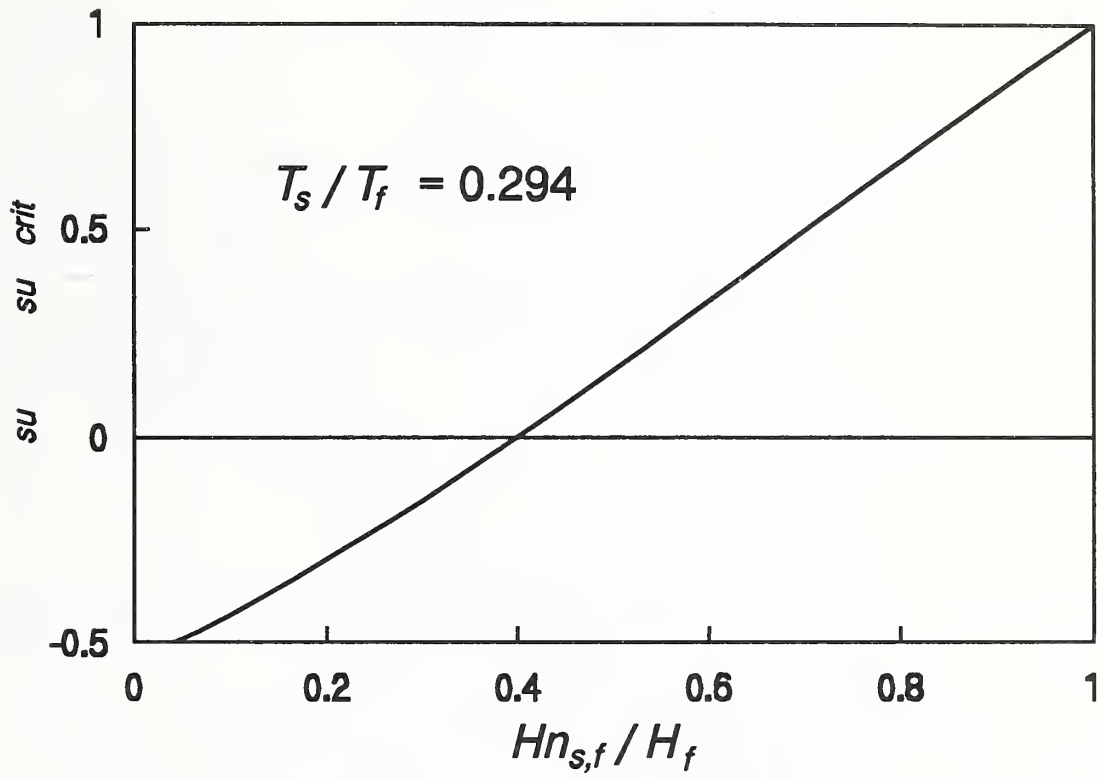

Figure 7. Height of neutral plane for pressurized staging area only connected to the fire floor

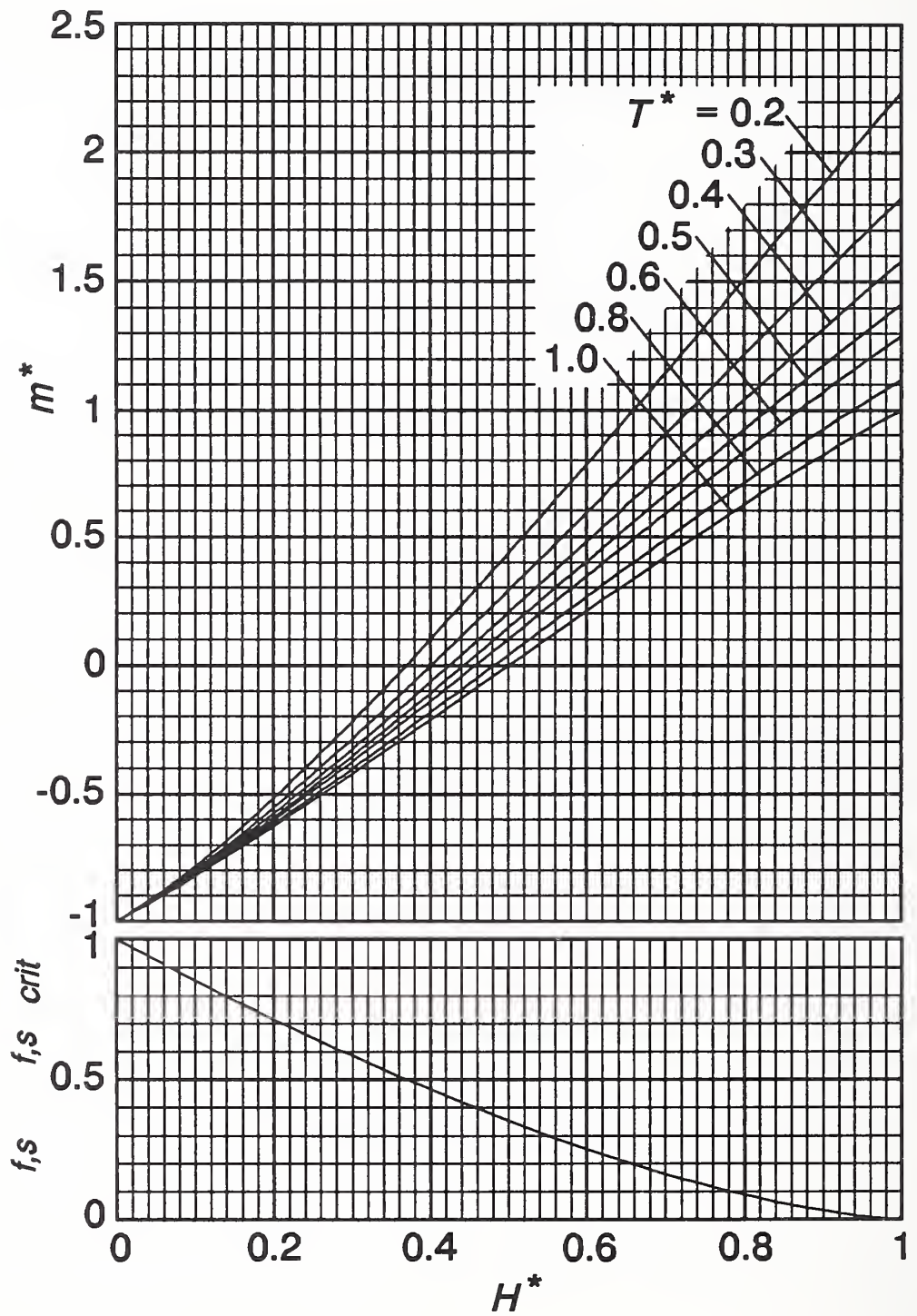

Figure 8. Nondimensional relation for bidirectional flow between two spaces at uniform temperatures

1-114A
(1.3-90)

U.S. DEPARTMENT OF COMMERCE
NATIONAL INSTITUTE OF STANDARDS AND TECHNOLOGY

BIBLIOGRAPHIC DATA SHEET

1. PUBLICATION OR REPORT NUMBER	NISTIR 4770
2. PERFORMING ORGANIZATION REPORT NUMBER	
3. PUBLICATION DATE	February 1992

TITLE AND SUBTITLE

Staging Areas for Persons with Mobility Limitations

AUTHOR(S)

John H. Klote, Harold E. Nelson, Scot Deal, and Bernard M. Levin

PERFORMING ORGANIZATION (IF JOINT OR OTHER THAN NIST, SEE INSTRUCTIONS)

U.S. DEPARTMENT OF COMMERCE
NATIONAL INSTITUTE OF STANDARDS AND TECHNOLOGY
GAITHERSBURG, MD 20899

7. CONTRACT/GRANT NUMBER	
8. TYPE OF REPORT AND PERIOD COVERED	

SPONSORING ORGANIZATION NAME AND COMPLETE ADDRESS (STREET, CITY, STATE, ZIP)

General Services Administration
Public Buildings Service
Office of Real Property Management
Washington, DC 20405

SUPPLEMENTARY NOTES

ABSTRACT (A 200-WORD OR LESS FACTUAL SUMMARY OF MOST SIGNIFICANT INFORMATION. IF DOCUMENT INCLUDES A SIGNIFICANT BIBLIOGRAPHY OR LITERATURE SURVEY, MENTION IT HERE.)

The National Institute of Standards and Technology (NIST) is engaged in a project funded by the General Services Administration (GSA) to evaluate the concept of staging area as a means of fire protection for persons with disabilities as it applies to Federal office buildings. There is a rising concern for the safety from fire of persons who cannot travel the building emergency exit routes in the same manner or as quickly as expected of able persons. One proposed solution for providing safety for persons with such disabilities is the provision of staging areas where they can "safely wait" until they can be assisted in safely leaving the building. The GSA has modified six buildings for fire protection of persons with mobility disabilities. Spaces that were turned into staging areas include passenger elevator lobbies, service elevator lobbies, sections of corridor, and rooms. Because these six GSA buildings were the first buildings ever to be retrofitted as discussed above, there were no precedents upon which to base the design or operation of the systems. Before this study the extent of the complexity of these systems and the interaction between the systems and people were unknown. It is not surprising that significant operational problems were uncovered with these first systems. These unavoidable problems coupled with the diversity of the applications in the six buildings resulted in a unique opportunity to learn about these systems. The conclusions were: (1) staging areas can be either a haven of safety or a death trap; (2) in many cases, the persons most needing the staging area protection may be unable to reach that area before their pathway (corridor or aisle ways) become lethal; and (3) the operation of a properly designed sprinkler system eliminates the life threat to all occupants regardless of their individual abilities.

12. KEY WORDS (6 TO 12 ENTRIES; ALPHABETICAL ORDER; CAPITALIZE ONLY PROPER NAMES; AND SEPARATE KEY WORDS BY SEMICOLONS)

Evacuation; flashover; handicapped; life safety; office buildings; refuge; smoke barriers; smoke control; smoke hazards; sprinkler systems.

13. AVAILABILITY

<input checked="" type="checkbox"/>	UNLIMITED
<input type="checkbox"/>	FOR OFFICIAL DISTRIBUTION. DO NOT RELEASE TO NATIONAL TECHNICAL INFORMATION SERVICE (NTIS).
<input type="checkbox"/>	ORDER FROM SUPERINTENDENT OF DOCUMENTS, U.S. GOVERNMENT PRINTING OFFICE, WASHINGTON, DC 20402.
<input checked="" type="checkbox"/>	ORDER FROM NATIONAL TECHNICAL INFORMATION SERVICE (NTIS), SPRINGFIELD, VA 22161.

14. NUMBER OF PRINTED PAGES

186

15. PRICE

A09

