

NEW RES PUB

MAR 10 1988

Polymer Composite Processing

Industry Workshop

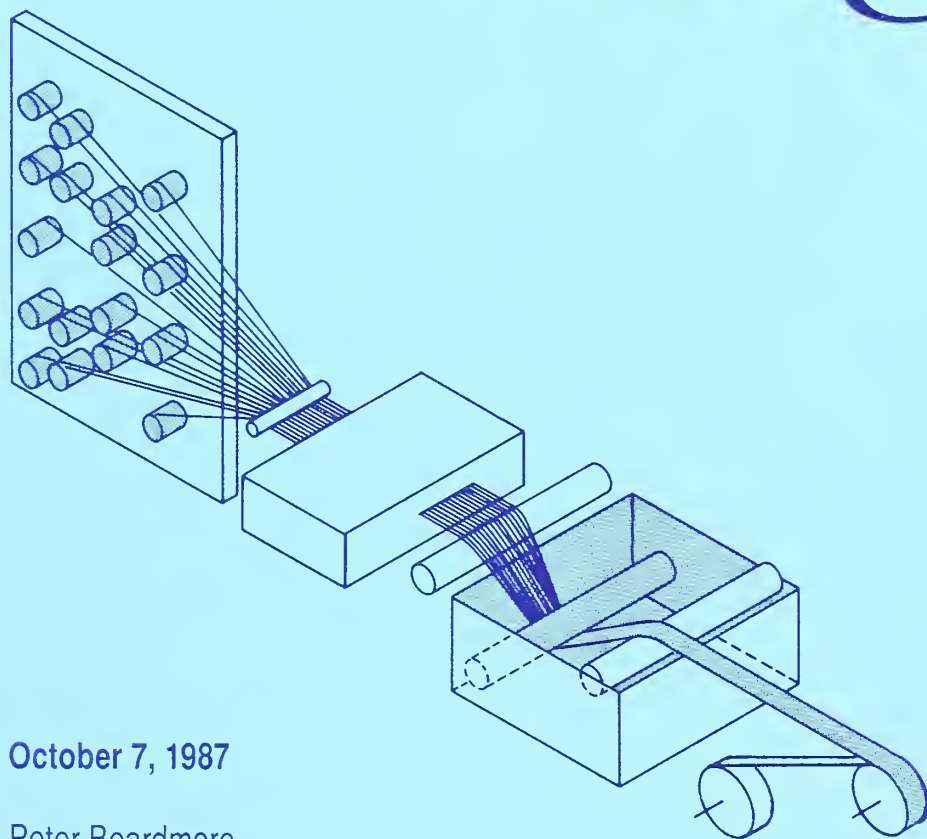

October 7, 1987

Peter Beardmore
Donald Hunston

U.S. DEPARTMENT OF COMMERCE
National Bureau of Standards
Institute for Materials Science and Engineering

IMSE

NBSIR 87-3686

POLYMER COMPOSITE PROCESSING
An Industry Workshop

Held at NBS, Gaithersburg, MD
October 7, 1987

Peter Beardmore* and Donald Hunston

* Ford Motor Company
Scientific Research Lab.
Dearborn, MI 48121

U. S. Department of Commerce
National Bureau of Standards
Institute for Materials Science and Engineering
Polymers Division
Gaithersburg, MD 20899

Issued February 1988

INDUSTRY WORKSHOP ON POLYMER COMPOSITE PROCESSING

Peter Beardmore
Ford Motor Co.
Scientific Research Lab.
P. O. Box 2053
Dearborn, MI 48121-2053

Donald Hunston
National Bureau of Standards
Institute for Materials Science and Engineering
Polymers Division
Gaithersburg, MD 20899

Report from workshop held at
National Bureau of Standards
October 7, 1987

U.S. DEPARTMENT OF COMMERCE
National Bureau of Standards
Institute for Materials Science and Engineering
Polymers Division
Gaithersburg, MD 20899

TABLE OF CONTENTS

Description	Page
Summary	4
Introduction.	6
Opportunities and Challenges.	6
Purpose of Workshop	7
Information Sought.	7
Program	9
Workshop Presentations.	9
Questionnaire on Processing Methods	11
Questionnaire on Scientific and Technical Barriers	11
Overview of NBS Reach Program	12
Current Activities.	12
Processing Studies.	13
Structural Characterization Studies	13
Performance Property Studies.	14
Expansion of NBS Research Program	14
Industrial Perspective: Automotive	15
Cost is a Major Factor.	15
Most Promising Processing Methods	15
Important Requirements for the Future	16
Industrial Perspective: Electronics.	17
Dimensional Stability is Critical	17
Other Important Requirements.	18
Industrial Perspective: Aerospace.	19
Automation is Major Trend	19
New Materials and Processing Methods.	20
Standard Tests and Data Validation.	21
Industrial Perspective: Fabricators.	21
Most Promising Processing Methods	22
Heat Flow and Fiber Orientation	22
New Materials	23

	Page
Discussion.	24
Workshop Composition.	24
Processing Methods.	24
Questionnaire Results	26
Comparisons by Industry	26
Aerospace	26
Automotive.	26
Electronics	27
Thermoplastics.	27
Five Most Promising Processing Methods.	27
Two Technologies that Complement Processing	28
Scientific and Technical Barriers	29
Need to Better Understand Processing.	29
Questionnaire Results	29
Six Most Important Barriers	31
Material Processing Parameters.	31
Temperature Gradients and Heat Flow	31
Fiber-Matrix Interface.	32
Standard Tests, Data Validation, and Data Bases	32
Morphology.	32
Surface Quality and Dimensional Tolerances.	33
Materials with Potential for the Future	33
Conclusions	34
Processing Methods.	34
Scientific and Technical Barriers	35
Appendix I: Attendance List.	37
Appendix II: Questionnaires.	39
Questionnaire 1	39
Questionnaire 2	40
Questionnaire 3	42

ACKNOWLEDGEMENT

The authors wish to express their appreciation to Mary Conneran, Joan Ruff, and Dr. S. S. Chang for providing the arrangements and organization that made the Workshop a success.

SUMMARY

This Workshop seeks to expand the use of polymer composites by analyzing the critical need for improved processing.

The Workshop Goals were to identify:

The most promising Processing Methods for the future
The critical Barriers to their implementation

The Attendees represent 23 different companies including composite users, suppliers, and fabricators.

Five Processing Methods were selected as most important for the future:

Pressure Molding
Transfer Molding
Filament Winding
Thermoforming
Pultrusion

Two Technologies that Complement Processing were also noted as very important.

Alternative Sources of Energy Input
Resin Coating of Fibers

The Workshop concluded that the Most Critical Technical Barriers to implementation of improved processing are inadequate understanding of:

Resin Flow and Fiber Orientation
Temperature Gradients and Heat Flow
Fiber-Matrix Interface
Data Validation, Test Standardization
Morphology Control
Surface Quality, Dimensional Tolerances

Additional information in these areas is needed to implement process control and automation which the Workshop felt were keys to more rapid, reliable, and cost effective processing.

The Workshop also identified three classes of materials that should be watched for future potential:

Thermoplastics
Liquid Crystalline Polymers
Molecular Composites

Companies represented at the workshop were:

ALCOA	AT&T
BF Goodrich	Boeing
Chrysler	Dexter
DuPont	Ferro
Ford	GenCorp
General Electric	Grumman
Hercules	Hysol Composites
IBM	Interez
Lockheed	Martin Marietta
3M	Phillips Petroleum
Rockwell International	SAMPE
United Technologies	

INTRODUCTION

In the past few years, government organizations, professional societies, and commercial groups have conducted studies to identify critical areas of emerging technologies that are vital to the international competitiveness of U.S. industries. Composites rank at or near the top of these lists. Although the U.S. presently enjoys a technological lead in some areas of composite technology and applications, the rest of the world is rapidly gaining on the U.S. and have now achieved equality in a number of important areas. The reports on emerging technologies emphasize the need for the U.S. to exploit the potential of composites to maximize international competitiveness.

Opportunities and Challenges

The area of composites which has the most potential in the next 5 to 15 years is mass-produced, commercial products using polymer based composites. Although considerable U.S. effort has concentrated on the development of DOD and aerospace applications for composites, much of the resulting information is of limited value for commercial applications where the primary emphasis is on cost effectiveness rather than performance with cost as a secondary factor. Manufacturing plays a critical role in the cost for these materials, so more rapid, cost effective, and reliable processing is often regarded as the single most important barrier to expanded use in commercial application.

The pressure for rapid implementation of these highly beneficial materials has led to rapid growth rates where the applications have out stripped the development of the corresponding science and technology base. It is now generally recognized that a major effort to improve this science base is essential, since the rapid growth rates can be maintained only by

extending the application of composites to the more cost sensitive commercial markets.

Purpose of Workshop

It is necessary to focus on those aspects of the science base which will have direct impact on the development of more cost effective fabrication. To identify these areas, this Industry Workshop was held at the National Bureau of Standards on October 7, 1987. Since polymer composites can be applied in a wide range of industries, and each will have a slightly different set of problems and constraints. It is important to identify common problems whose solution will have a broad impact. These problems can then be given highest priority. To this end, the Workshop was organized with representatives from a variety of users, manufacturers and suppliers in the composites field. The users included the automotive, electronics, and aerospace industries while the suppliers were manufacturers of resins and fibers. Companies that prepare starting materials such as preimpregnated fiber tape and cloth were represented as were companies that fabricate small parts for the larger industrial users.

There were a total of 25 attendees representing 23 companies. A full attendance list is given in Appendix I. In addition, comments were supplied by a number of industrial people who could not attend but expressed great interest in the workshop.

Information Sought

The meeting was organized so the results would reflect the position of industry. Two questions were addressed. First, what are the generic processing methods that will be of most interest to industry during the next 5 to 15 years? Second, what are the scientific and technical barriers that hinder the implementation and effective use of these methods? The answers to these

questions are of interest to many people in the composites field but will also help the National Bureau of Standards (NBS) identify specific projects for their expanded composites research program.

PROGRAM

The workshop was a day long meeting divided into two parts with presentations and focused discussions in the morning and general discussions aimed at reaching a consensus in the afternoon. The program is given in Table I. In preparation for the meeting attendees were given the opportunity to identify the processing methods and technical barriers expected to be important to their industry or the industries they supply in the next 5 to 15 years. This information was combined with results generated during the discussions to prepare questionnaires that were distributed at appropriate points in the meeting. The results help focus the discussion and assure that everyone had an opportunity to contribute. The questionnaires are included as Appendix II.

Workshop Presentations

The initial presentations in the meeting described the purpose of the workshop, the current NBS composites program, and the general plans for future expansion of this effort. The first questionnaire was then distributed. It listed all of the processing methods suggested by attendees on their application forms. The audience was asked to add any important processing methods that were not already listed and indicate which methods they felt would be important to their industry or the industries they supply in the future.

Presentations then followed by representatives from 4 industry sectors: automotive, electronics, aerospace, and fabrication. The speakers gave a general overview from the

TABLE I: PROGRAM

Composite Processing Workshop
October 7, 1987
Lecture Room D
Administration Building

Cochairmen: Peter Beardmore, Ford, and Donald Hunston, NBS

Questions to be addressed:

What are the generic processing methods that will be important to your industry in the future (i.e. 5 to 15 years)?

What are the long-term technical and scientific barriers that must be overcome to fully utilize these methods?

Time	Description	
8:30	Registration	
9:00	Welcome to NBS	Ray Kammer, Deputy Director of NBS
9:10	Introductions & Charge to Workshop	Les Smith, Chief Polymers Div., NBS
9:25	Background of NBS Composites Program and Initiative	Don Hunston, NBS
9:55	Questionnaire on Processing Methods	
10:00	Industry Prospective on Processing Methods and Problems	
	Automotive	Carl Johnson, Ford
	Electronics	Don Barr, IBM
11:00	Coffee	
	Aerospace	Sam Dastin, Grumman
	Fabricators	Joe Reardon, Hysol
12:00	Questionnaire to Rank Processing Methods and Identify Technical Barriers	
12:15	Lunch	
1:15	Questionnaire to Identify Scientific and Technical Barriers	
1:30	Results from Questionnaire to Rank Processing Methods	
1:35	Discussion of Processing Methods Ranked as Most Important	
1:55	Results from Questionnaire to Identify Barriers	
2:00	Discussion of Scientific and Technical Barriers	
3:15	Coffee	
3:30	Chairmen's Summary	
3:45	Adjourn	

perspective of their industry, and following each presentation, knowledgeable members of the audience augmented the presentation with comments based on their own experience and expertise.

Questionnaire on Processing Methods

The second questionnaire which listed all of the processing methods identified during the morning was then distributed. The attendees were asked to indicate in priority order the methods that they felt would be most important to their industry or the industries they supply in the next 5 to 15 years. Equal ratings were given when an attendees felt 2 or more techniques were equally important. To analyze these results, 5 points were given for each first place rating, 4 for each second place rating, etc. The results provided a list indicating what techniques the attendees, as a group, considered most important. Since the questionnaires also obtained information about the attendee's background, some inferences concerning differences in priorities between industries could also be made.

Questionnaire on Scientific and Technical Barriers

The third questionnaire listed all of the technical barriers mentioned by attendees on their application forms or in the morning's discussions was completed after lunch. Each person was asked to identify those barriers which are hindering or will hinder the implementation of the composite processing methods identified earlier in the meeting. The time frame of interest was again 5 to 15 years. The results were analyzed by constructing a list of items that were rated as important by the largest number of people.

The results of the second and third questionnaires were then discussed, and a consensus as to which processing methods and technical barriers were most important was sought. The sections that follow will present brief summaries of the presentations, a

description of the questionnaire results, and a report of the final conclusions, and a discussion of the efforts that achieved this consensus.

OVERVIEW OF NBS RESEARCH PROGRAM

The first presentation in the workshop was a review of the current NBS composites research program and an outline of the preliminary thinking for program expansion.

Polymer composites represent an important emerging technology where major opportunities exist for applications in the commercial sector. In many cases the impediment that hinder the expanded use of these materials involve questions of measurement methods and test data. As a result NBS has had a composites research program for a number of years. The potential for these materials has now reached the point, however, where a major expansion of the NBS effort is needed. Current plans call for growth of this program in 1988 by a factor of 2 to 3 with further growth in 1989 being considered. An important use for the conclusions from this workshop will be to help NBS define research projects that provide the type of information needed by industry. Cooperative programs will also be encouraged.

Current Activities

The research projects in the NBS program are divided into three tasks which focus on processing, structure, and performance. The overall objective is to investigate how the properties of a composite depend on the internal structure produced by the processing and the properties of the fibers and the matrix. Such relationships are the key to more effective processing as well as improved performance. The programs draw on the strength of NBS in the measurement field. A complete description of the NBS program is contained in the Polymer Division's Annual Report, but a brief overview will be given here.

Processing Studies: In the area of processing, the projects focus on cure monitoring for thermosets and consolidation monitoring for thermoplastics. The objectives are threefold: to develop new measurement methods which offer important improvements, to maintain a variety of monitoring techniques for calibration and testing of methods under development, and to apply multiple monitoring techniques to the study of model systems so a better fundamental understanding of the events that occur during processing can be obtained. There are currently 10 different process monitoring techniques available in this program. These methods characterize systems on sensitivity levels ranging from the covalent bonds that are involved in chemistry to the macroscopic viscosity that controls flow and consolidation. The results generated in these projects provide measurement techniques with potential for on-line process control and an understanding of processing events which can be useful in designing new fabrication procedures.

Structural Characterization Studies: In the task on structure the objective is to characterize the composite so that this information can help bridge the gap between processing and properties. A knowledge of the structure can help explain why a given set of properties results from a particular processing cycle. The structures of interest includes flaws, voids, fiber orientation and dispersion, morphology, crystallinity, and the molecular networks structure present in cross-linked systems. The current work involves the development and use of small angle neutron scattering to determine the network structure of thermoset resins. This represents the first time such structure can be characterized. For specific materials the technique has already revealed the effects of changing the processing conditions and the molecular level deformations that occur when the sample is loaded to levels just below the failure point. The results are useful for developing processing-structure-property relationships.

Performance Property Studies: In the task on performance the objective is to study the behavior of composites in terms of the properties of their fibers and resins. Although all aspects of behavior are of interest, fracture is of particular concern. A major current program is investigating toughened composites which utilize high fracture energy resins to improve the composite behavior. The experiments help explain both why the resins are tough and how this behavior is translated into the composite. This information provides a valuable tool for predicting composite properties and generating improved resins.

Expansion of NBS Research Program

The proposed expansion in the NBS composites program will focus on processing. The major change will be in the processing task where several processing facilities will be constructed. The results from this workshop will help determine what types of processing facilities would be most appropriate in terms of the future needs of industry. These facilities will be used to experimentally address the scientific and technical barriers that limit processing efficiency. The workshop results will provide industry's priorities for these technical barriers. In the preliminary planning for this program, three possible areas were identified. First, the need to develop a better understanding of the events that occur during processing appears to be an important area. Second, the application of the process monitoring techniques, developed in the current NBS program, to on-line monitoring represents a possible program direction that takes advantage of previous work. Third, the extension of on-line process monitoring to process control through the development of process models is also an exciting possibility.

The structure and properties tasks in the NBS program will also be affected by the expansion since samples must be characterized to establish the relationships between processing

and performance. One focus of the program expansion will be the characterization of structure. This draws heavily on NBS's measurement expertise. Examples of areas where such characterization are needed include: network structure for thermosets, crystallinity for thermoplastics, defects and crystallinity for fibers, and adhesion and morphology for interface regions. Research in the current program has already developed unique measurement tools for some of these properties, but much more work needs to be done.

INDUSTRY PERSPECTIVE: AUTOMOTIVE

In the automotive industry it will be difficult for composites to compete in terms of appearance and cost with metal stamping for semi-structural components such as body panels. Dent resistance is an advantage of composite body panels, however, structural parts offer the biggest opportunity for composites. The key to success in the automotive area for all types of composite parts is cost effectiveness. The specific needs for cost effective fabrication are high speed processing methods, low cost fibers, and resins that are suitable for rapid processing.

Cost is a Major Factor

There are two important features of composites that can contribute to the goal of cost effective processing: the relative ease of making design changes and the ability to integrate many components into a single part. Design changes are important because the current trends are toward more models and more frequent model changes. The use of composites facilitates large scale integration but imaginative processing methods are often required.

Most Promising Processing Methods

Two processing methods are felt to offer the most promise for the time period between 5 and 15 years from now: compression

molding and transfer molding. Compression molding has the advantage that it is an established procedure. Unfortunately, it also has two important disadvantages. First, with present technology the part size and complexity are limited. This controls the cost reductions that are possible without the development of new technology. Second, the parts made by compression molding are predominately 2 dimensional since the complexity and thickness in the third direction are limited.

The second processing technique that shows promise for automotive applications is transfer molding. Four factors make this method particularly attractive. First, relatively low pressure is required because only the pure resin is transferred. Second, accurate placement of the reinforcement can be achieved with complex variations in type and orientation throughout the part. Third, a high degree of complexity is possible not only for the reinforcement but also for the shape. Finally, the part can be 3 dimensional since deep forms can be used. The major shortcoming for transfer molding is that the preparation of the reinforcement preform is often time consuming and labor intensive. For simple performs a stamping process can be used, but more complex performs with positional variations in the kind and orientation of the reinforcement must now be prepared by hand. Ultimately, this process must be automated.

In automotive processing both thermosets and thermoplastics are being considered. Thermoplastics have advantages such as stability during storage, possible simplifications in repair, and the potential for an excellent surface finish. Thermosets, on the other hand, have low viscosities during processing, so they can achieve the flow necessary to make larger and more complex parts.

Important Requirements for the Future

Two other areas of importance for automotive applications of composites are crash management and adhesive bonding. Crash

management is being addressed through the design of structures that can absorb energy and thereby minimize injury to the vehicle's occupants. Crack management considerations influence the designs that must be fabricated and consequently, the processing required. Adhesive bonding is important because it increases flexibility in both design and manufacturing. The desired high production rates require rapid cure materials that need a minimum of surface preparation. In addition more data are needed on long term durability and environmental effects on adhesively bonded joints.

One final point of concern in automotive applications is the need to generate a superior surface finish on those sections of a part that are visible in the application (it is worth noting that many parts are not visible). Processing plays a major role in determining surface finish so the effects of processing on surface quality are a subject of major concern.

INDUSTRY PERSPECTIVE: ELECTRONIC

The applications of composites in the electronics field are very broad and range from equipment housings to chip encapsulation and circuit boards. A wide variety of processing methods are needed. For example, housings may be made by injection molding, circuit boards by press or autoclave fabrication, and chip encapsulation by transfer molding.

Dimensional Stability is Critical

An important characteristic of the electronics industry is the short time required for technology to move from the high end systems to the mass market equipment. Consequently, much can be learned about the processing needs for the future by considering today's problems in the high technology systems. One example is multilayer circuit boards. The current state-of-the-art boards are large, 50 cm or 60 cm on each side, and can contain as many as

20 conducting and 20 non-conducting layers. The electronic components mounted on the board are interconnected through complex patterns created in the conducting layers and connections between these layers made via a large number of small holes, 0.4 mm in diameter, drilled through the board. There can be 20,000 or more such holes in each board. The holes are plated with conducting material to provide an electrical path. Since each hole must make electrical contact with some layers and not with others, the criteria for alignment and dimensional stability are extremely severe. As this technology moves to larger volume equipment, the need for increased production speeds grows and the challenges become even greater.

Dimensional stability is also a concern for less sophisticated composite parts. One reason for this lies in another important trend for the future in the electronics industry, i.e. a move to fiber optics for connections. The use of fiber optics will require a high degree of alignment for proper signal transfer.

Other Important Requirements

In addition to dimensional stability, there are a number of other problems areas where a better understanding of the science involved represents the key to progress. The dielectric constant of a material is important for electronic applications since this controls design factors such as circuit density. To optimize the dielectric constant, however, requires a knowledge of structure-property relationships that does not now exist. Thermal expansion and high temperature performance are also important parameters for electronic applications. Electronic systems often undergo thermal cycles that can cause problems. The most severe thermal shock occurs during processing when connections are soldered.

Chemical resistance is another concern of particular interest for electronics. The circuitry is generally introduced by

processes which involve exposure to chemical agents for the addition or removal of circuit layers. Any composite materials present must therefore be resistant to these fluids. A fifth area of importance for electronics is interface behavior. On circuit boards the electronics must be well bonded to the base composite layer, and interconnections must provide reliable contacts. Proper control of the interfaces present in these situations requires a better understanding of the features that control the interaction between two materials.

One final topic with strong implications for the electronics industry is the application of process control to the fabrication of composite components. Such control is needed to improve the speed and reliability of fabrication. Achieving this goal, however, requires a better understanding of the resin flow during processing, and how this flow can be modeled and controlled.

INDUSTRY PERSPECTIVE: AEROSPACE

The use of composite components in aerospace has a longer history than in other industries, but important challenges remain. Although applications in structural parts have received the most attention, composites also find widespread use in nonstructural parts. Thus the processing methods of interest to aerospace extends from sophisticated autoclave fabrication to simple compression molding. In both structural and nonstructural applications, the needs are for low weight and reduced cost. With structural parts, features such as damage tolerance and crashworthiness are also important while nonstructural parts can have a wide range of requirements, such as surface finish, heat resistance, strength, etc., depending on the application.

Automation is Major Trend

The aerospace market is characterized by low production and high performance, but cost is also a concern. Perhaps the most

important trend in aerospace processing today is the move to process automation. Two major driving forces for this move are reduced cost and increased reliability. The highly labor intensive fabrication procedures initially used are now being replaced by production facilities with a high degree of robotics.

The drive for automation gives rise to a need for an increased scientific understanding of processing. Effective automation is much easier when the process is understood. Moreover, such knowledge is essential for implementing process and control, and this is important to take full advantage of automation. Consequently, automation, processing science, and process control are closely linked areas where advancements will have direct impact on composite fabrication.

New Materials and Processing Methods

Two other trends in aerospace are the introduction of new materials and the development of new processing methods. There are two important factors behind the drive for new materials: the desire for higher temperature capabilities and the need for improved properties such as damage tolerance. The materials being developed are in two general classes: multicomponent, toughened thermosets and high temperature thermoplastics. In both cases the improvements in properties are often coupled with increased difficulties in processing. This results in a need to develop new or modified fabrication techniques and a better understanding of the events that occur during processing so that effective fabrication cycles can be designed.

An example of the development of new or modified processing methods results from the requirement that some partially crystalline thermoplastics must be cooled rapidly to achieve the desired morphology. The use of heated head tape laying machines and LASER assisted tape laying processes (the LASER providing localized heat) offer considerable promise. Non-autoclave curing

is a technique modification being studied in several programs. A third example is advanced types of pressure molding that are being sought as replacements for certain autoclave procedures. Although these and other new methods may offer considerable promise, many also increase the complexity of processing. Consequently, the need for a better understanding is important if the potential of these new methods is to be fully explored.

Standard Tests and Data Validation

One final topic worth mentioning is test method standardization and data validation. The cost of certifying a material for structural use in airplane construction is extremely high. Since each company must separately evaluate and qualify some of the same materials with their own tests, this cost is often duplicated. To make matters worse a composite must be specified not only in terms of the resin and fiber involved but also by how these constituents are processed. This greatly increases the number of possible materials and thus the cost of testing and evaluation. With regard to processing there are three areas where problems associated with testing are a concern: specification development and evaluation of raw materials, the acquisition of material property data for the design of processing cycles, and the characterization of fabricated parts to evaluate the success of fabrication.

Although many groups are actively involved in efforts to develop materials data and the associated data bases, there are important questions that remain unaddressed. Two examples are the lack of a method to uniquely define a composite material and the absence of standardized tests in many important areas.

INDUSTRIAL PERSPECTIVE: FABRICATORS

Fabricators are often smaller companies that specialize in making certain types of parts for major users but can also be

divisions of larger companies that either use composites or supply the starting materials. During the discussion in this section of the workshop three topics were addressed: potentially important processing methods for the future, fabrication problems related to materials and fibers, and new material systems that have potential for composites.

Most Promising Processing Methods

In the future, current processing methods like compression molding and injection molding will continue to find major use by fabricators although improvements in these techniques will undoubtedly be made. Transfer molding is a particularly promising method for the future because it has flexibility for use with new resin and fiber systems. Powder technology for prepreg preparation shows potential for use with materials that are particularly difficult to handle by normal methods. Such materials often have outstanding properties but cannot be utilized because processing by conventional methods is so difficult. Future fabrication procedures will also employ alternative forms of heat generation. Controlling energy input is important for effective processing, and sources such as LASERs and microwave radiation offer potential for greater control.

Heat Flow and Fiber Orientation

When processing thermosets, an important consideration is the combined effect of applied heat and the heat generated internally by the exothermic chemical reactions. Since the reaction rates are controlled by temperature, it is important to have the proper temperature history throughout processing. It is extremely difficult to achieve acceptable temperature histories at all points within the part, particularly with thick components. To address this problem requires improvements in our basic understanding and modeling capability. Another problem is the control of fiber orientation, dispersion, and degradation during processing. This is particularly critical in fabricating short

fiber composites. The ability to predict fiber behavior in such processes needs to be improved. Better models to relate the effects of fiber length and orientation to the properties of the composite are also needed. Such models are particularly useful for separating those processing parameters that really do affect performance in the composites from those that do not.

New Materials

Future processing will need to deal with new material systems such as polymer blends, alloys, and interpenetrating networks. Such materials offer improved properties but their complexity will require more exacting process control. Consequently, a better scientific understanding of these materials and how they behave during fabrication is required.

DISCUSSION

Following the industry overviews, the Workshop turned to open discussion aimed at reaching a consensus. The first step was to report the results of the questionnaires. In addition to answering questions about processing methods and barriers, the results also provided information on the expertise of the Workshop attendees. It is instructive to examine these results first.

WORKSHOP COMPOSITION

In the 25 attendees, 14 listed themselves as composite users and 6 as suppliers while 5 indicated they were involved in both. When asked about their primary market, 5 specified aerospace, 4 automotive, 3 electronics, 2 fabrication, 8 a mixture of markets, and 3 designated thermoplastics as their prime interest. Those indicating a mixture of markets listed not only the applications mentioned above but also sporting goods, marine uses, and industrial products. In general, therefore, the workshop represented a highly diverse group with a relatively balanced range of interests.

PROCESSING METHODS

The workshop discussion led to a consensus on the five most important processing methods for the future. These are listed in Table II. The common trait that links all five methods is their potential for development into systems capable of rapid production. In addition the workshop identified two technologies that complement processing. The attendees felt these technologies, which are also listed in Table II, held great promise for the future. A discussion of these conclusions, and the process that led to them is given below.

TABLE II: PROCESSING METHODS AND TECHNOLOGIES SELECTED AS MOST IMPORTANT FOR FUTURE (5 TO 15 YEARS)

PROCESSING METHODS

Pressure Molding
Compression Molding
Autoclave Molding

Transfer Molding
Reactive
Nonreactive

Filament Winding

Thermoforming

Pultrusion

IMPORTANT TECHNOLOGIES THAT COMPLEMENT PROCESSING

Alternative Sources of Energy

Resin Coating of Fibers
Preparation & Processing

Questionnaire Results

The first step in this process was for the workshop to consider the results from the second questionnaire which asked attendees to prioritize the list of processing methods in terms of potential for the future. The nine methods with the highest ratings in order of decreasing priority are:

- Compression Molding
- Resin Transfer Molding
- Alternative Sources of Heat
- Filament Winding
- Autoclave Molding
- Resin-coated Fibers
- Thermoforming
- Reactive Transfer Molding
- Pultrusion

The first two methods were rated significantly higher than the remaining seven.

Comparisons by Industry

Aerospace: Some interesting differences could be noted among the various industry segments. The processing methods identified as important by the aerospace group differed from the general list only in that transfer molding was ranked 10th and reactive transfer molding was not listed while high temperature processing and adhesive bonding were included. It is interesting to note the importance given to adhesive bonding, here as well as in the earlier discussion during the automotive section. Nevertheless, adhesion bonding is not generally thought of as a processing technique.

Automotive: Those responding for automotive interests also produced a list quite similar to the general ratings. The

differences were that long fiber processing and SMC forming were included while filament winding and autoclave molding were not.

Electronics: The responses associated with the electronics industry listed fewer processing techniques. The focus was on compression molding, resin transfer molding, and injection molding. Surprisingly, injection molding did not appear in the top items on the lists from other industry groups.

Thermoplastics: The list from the thermoplastics sector did not include transfer molding and autoclave processing, but powder impregnation of fibers was rated very highly. Clearly, difficulties associated with the preparation of high quality prepreg are important for this industry segment.

Five Most Promising Processing Methods

Although the differences outlined above are interesting, the most significant observation is the strong similarities that exist among the lists. This commonality made it much easier to achieve a consensus. Beginning with the general list from the questionnaire, the workshop first decided to combine resin transfer molding with reactive transfer molding and list both under the heading of transfer molding. It was felt that much of the technology involved in the two methods shared a common base, and the problems are also quite similar. The discussion then focused on compression molding. It was decided to combine compression molding and autoclave molding under the term pressure molding. In both cases the combination of heat and pressure are used to create the final part. Of particular interest to the workshop was the potential for future improvements in autoclave molding that would simplify the processing and improve the speed. It was suggested that some future high speed processes might move out of the autoclave environment and take on some of the characteristics of compression molding.

Transfer molding and pressure molding were rated significantly higher than the other three techniques in the list from the questionnaire: thermoforming, filament winding, and pultrusion. Nevertheless, these three methods received widespread enthusiasm from attendees representing a variety of industries. It was noted in the discussion that all five methods have the potential for development into systems capable of rapid production. This was clearly a key factor for the attendees.

Two Technologies that Complement Processing

The workshop then discussed resin coated fibers and alternative sources of heat. It was decided that these are not processing techniques but are better described as technologies that aid and complement processing. Since they were so highly rated a separate category was established for these two items. The discussion first retitled alternative sources of heat to alternative sources of energy input to include all possibilities. The list of potential sources included microwave, dielectric, and ultrasonic generators and LASERs. The energy supplied could be used either to initiate or promote chemical reactions in thermosets or to melt materials or change viscosities in thermoplastics. A major advantage of such approaches is the potential to gain better control over the energy input in terms of the time period involved, the area where the energy is applied, and its intensity. This will be increasingly advantageous as process control and automation are implemented.

The other technology discussed was resin coating of fibers, such as in prepreg fabrication. The attendees considered this topic to be very important because new procedures could improve both processing speed and versatility. A number of such procedures are currently in development. They include commingled fibers, fibers prepared with resin coatings, and powder processing to prepare prepreg. The workshop felt that the development of such methods should be encouraged.

SCIENTIFIC AND TECHNICAL BARRIERS

The items identified by the workshop as the most important scientific and technical barriers to improved processing are summarized in Table III. These barriers represent areas where the attendees felt there was an urgent need for scientific study to improve our knowledge and understanding. This is needed for the development of improved processing methods, the implementation of on-line process control, and the application of automation for increased processing speed and reliability. A discussion of these barriers and the workshop's efforts in developing this list are given below.

Need to Better Understand Processing

The first conclusion in the workshop's discussion was that the most critical barriers involve deficiencies in our understanding of the chemical and physical changes that occur during processing. The task then was to determine in which areas an increase in our knowledge would have the most effect on improving fabrication and developing on-line process control.

Questionnaire Results

To assist in identifying these areas, the results of questionnaire 3 were presented. In order of decreasing priority the eight most important items listed by the attendees were:

- Adhesion and Fiber/Matrix Interface
- Resin Flow Behavior
- Data Validation/Data Base Systems
- Temperature Profile and Thermal Gradient Control
- Heat Transfer and Thermal Conductivity
- Toughening Mechanisms
- Fiber Alignment and Control
- Phase Separation

TABLE III: RESULTS FOR SCIENTIFIC AND TECHNICAL BARRIERS

MOST IMPORTANT BARRIER IS INABILITY
TO UNDERSTAND AND CONTROL THESE FEATURES

Material Processing Parameters

Resin Flow
Flow Behavior in Composite
Fiber Distribution and Orientation

Temperature Gradients and Heat Flow

Temperature Profiles & Gradients
Heat Flow and Thermal Conductivity
Energy Input (Curing or Melting)

Adhesion - Fiber/Matrix Interface

Data Validation - Database Development - Test
Standardization

Morphology

Phase Separation (Toughened Systems)
Crystallinity

Surface Quality - Dimensional Tolerances

POTENTIALLY IMPORTANT MATERIALS FOR THE FUTURE

Thermoplastics

Liquid Crystalline Polymers

Molecular Composites

The results did not show any particular pattern by industry, and this probably facilitated efforts to reach a consensus. The first step in this process was to note that several of the topics were specific examples of more general areas which had wide spread interest among attendees. These areas were identified, and then the discussion focused on filling the gaps and omissions that were present in the list.

Six Most Important Barriers

Material Processing Parameters: The workshop first examined the importance of resin flow behavior and the effects of fiber alignment. The attendees felt that the control of these parameters was critical to successful processing. The current state of our understanding can and should be improved to show how these parameters relate to performance, and how they should be controlled during processing to achieve the desired results. The flow behavior of both the resin itself and the resin in the composite needs to be studied. The workshop grouped these topics together under the title Material Processing Parameters, and ranked the need to develop a scientific understanding of this area very highly.

Temperature Gradients and Heat Flow: The workshop then reached a consensus that more needs to be learned about temperature profiles and gradients, heat flow, and thermal conductivity within parts during processing. This is particularly important in thick parts where it may be quite difficult to achieve uniform cure. Although the temperature history within the sample is critical to processing, our current understanding does not permit the modeling and control that is needed. The use of alternative sources of energy input, as discussed earlier, could have a major impact here.

Fiber-Matrix Interface: The workshop felt that fiber-matrix interface properties, such as adhesion, have a direct effect on composite performance. At present only the simplest correlations can be made. It is important to increase our knowledge and modeling capability in this area. In addition, there is a need to identify parameters that affect the interface properties so that they can be controlled both through the proper choice of starting materials and the appropriate processing.

Standard Tests, Data Validation, and Data Bases: The area of data validation and data base development was then discussed by the workshop. The attendees felt this was a critical area and identified test method standardization as another major aspect of the problem. Many attendees expressed concern about difficulties in specification testing for acceptance of starting materials and performance testing of composites to determine if processing was successful. The discussion concluded by expressing a strong belief that this area needed to be addressed.

Morphology: The topics of toughening mechanisms and phase separation were also rated highly in the questionnaire. The connection between these two items and processing is that toughening is generally accomplished through the use of additives, many of which phase separate, and the morphology of these multicomponent systems controls the toughening. It is critical to know what morphology is needed, and how it can be generated during fabrication. A closely related area is the control of crystallinity in partially crystalline thermoplastics. The development of crystallinity during processing must often be controlled to achieve the desired performance in the finished composites. At present, a largely empirical approach is used to develop processing procedures for both types of systems, but this is not very efficient and makes it difficult to translate processing procedures to new materials. To improve this

situation, a better scientific understanding of these effects is required.

Surface Quality and Dimensional Tolerances: The workshop discussion also concluded that dimensional control and reproducibility are vital to a wide range of applications. Examples include the fabrication of circuit boards for electronic applications and the generation of high quality surface finishes on automotive parts. Although such components can be manufactured today, the processing is expensive, slow, and not successful for all applications. In the future greatly increased speeds and decreased costs will be required, and this means a better understanding of and control capability for the factors that influence dimensional tolerance and surface quality will be needed.

Materials with Potential for the Future

The final topic discussed in the workshop was the potential of three new classes of materials: thermoplastics, liquid crystalline polymers, and molecular composites. The attendees felt that new processing requirements will be needed to take full advantage of this potential. Thermoplastics are already considered in much of the preceding discussion, but the other two classes of materials may give rise to needs not covered here. Consequently, developments related to these materials need to be watch closely.

CONCLUSIONS

The workshop described in this report addresses the need for improved processing of polymer based composites by identifying areas where advances would have the most impact. To do this, two questions were asked. First, what are the generic processing methods that will be of most interest to industry during the next 5 to 15 years? Second, what are the scientific and technical barriers that hinder the implementation and effective use of these methods?

The workshop participants represented 23 different companies involving a wide range of users, suppliers, and manufacturers. The meeting employed overview presentations, questionnaires, and discussions to reach a consensus among the attendees.

Processing Methods

Five processing methods that all attendees considered important for the future were identified. Two of these were rated highest: pressure molding and transfer molding. Pressure molding includes both compression molding and autoclave processing while transfer molding includes both reactive and non-reactive materials. The three remaining processing methods were given roughly equal ranking; they are thermoforming, filament winding, and pultrusion. A major common feature for all five techniques is their potential for development into rapid, cost effective production methods.

In addition to the five selected processing techniques, the workshop also identified as very important two technologies that complement processing. The first is alternative sources of energy input to initiate or facilitate processing. Examples cited include the use of microwave, dielectric and ultrasonic sources or

LASERs. The second technology identified as important is the preparation of the resin-fiber starting materials. Three examples were mentioned: powder processing for prepreg manufacture, commingled fibers, and resin coated fibers.

Scientific and Technical Barriers

The workshop concluded that the most critical scientific and technical barriers are deficiencies in our understanding of the events that occur during processing. Six areas were identified where these deficiencies have the most adverse effects on processing and, consequently, represent the primary barriers to improved fabrication. These deficiencies are particularly important because they hinder the implementation of process control and automation which are the keys to more rapid and reliable processing.

The attendees felt the most important problem is the need to understand and control resin flow and fiber orientation during processing. The second area where improvements are needed is modeling and control of temperature and heat flow. The concerns here ranged from temperature levels and gradients during processing to the use of alternative sources of energy input. Fiber-matrix adhesion is the third most important area cited by the workshop while data validation, data bases development, and standardized tests was ranked fourth. The control of morphology during processing was listed next. Such control is particular needed for crystallinity and phase separation in two phase toughened systems. Control of finish and dimensional tolerances is the final area identified. This is of particular concern to the automotive and electronics industries, but others expressed interest as well.

One final point is the suggestion that three classes of materials offers significant potential for the future and should be watched closely: thermoplastics, liquid crystal polymers, and

molecular composites. The first category is already included in much of the discussion above. The second and third, however, are newer and other problems may emerge.

APPENDIX I: ATTENDANCE LIST

Don Barr
IBM
T50 257-3
1701 North St.
Endicott, NY 13760

Peter Beardmore
Ford
Scientific Research Lab.
P.O. Box 2053
Dearborn, MI 48121-2053

Paul J. Biermann
Chairman, Baltimore-Washington
SAMPE Chapter
Applied Physics Laboratory
Johns Hopkins University
14-704 Johns Hopkins Rd
Laurel, MD 20707

David Boll
Hercules Inc.
Aerospace Products Group
Bacchus Works
Magna, UT 84044-0098

Walt Brueggeman
Ferro Corporation
7500 E. Pleasant Valley Rd.
Independence, OH 44131

Samuel Dastin
Grumman Aerospace Corporation
Mail Stop B10-25
Bethpage, NY 11714

J. William Davis
3M Technical Center
Research and Development
Bldg. 201-1F-02
St. Paul, MN 55144-1000

Thomas Dudek
GenCorp. Inc.
2990 Gilchrist Road
Akron, OH 44305

Mahammad Ibrahim
Martin Marietta Labs.
Research and Development Lab.
1450 S. Rolling Road
Baltimore, MD 21227

Carl F. Johnson
Ford
Scientific Research Lab.
Room S-2046
P.O. Box 2053
Dearborn, MI 48121-2053

Tim W. Johnson
Phillips Petroleum Co.
Research and Development
155 CPL
Bartlesville, OK 74004

Chuk Leung
Rockwell International Science
Center
1049 Camino Dos Rios
Thousand Oaks, CA 91360

Jean Lynn
Chrysler Motor Corp.
12800 Chrysler Dr.
Detroit, MI 48013-1118

Louis T. Manzione
AT&T
Bell Laboratories
Room 7E-205
600 Mountain Avenue
Murray Hill, NJ 07974

Richard G. Parker
BF Goodrich
BF Goodrich Research Center
9921 Brecksville Rd.
Brecksville, OH 44141

Joe Reardon
Hysol Composites Inc.
17960 Englewood Dr.
Cleveland, OH 44130

Charles L. Ryan
ALCOA Laboratories
ALCOA Technical Center
Bldg C
Alcoa Center, PA 15069

George Schmitt
IBM
T22/257-2
1701 North St.
Endicott, NY 13760

Dan Scola
United Technology Research
Center
Mail Stop 24
Silver Lane
East Hartford, CT 06108

James R. Scott
Boeing Commercial Airplane Co.
P.O. Box 3707, MS 73-43
Seattle, WA 98124-2207

Dave Shimp
Interez Inc.
9800 Bluegrass Pkwy.
Louisville, KY 40299

Allan Shultz
General Electric
Corporate R&D
K-1 4B37
1 River Road
Schenectady, NY 12345

Fred Tervet
Lockheed-California Company
Dept. 47-17
Building 369 B-6
Burbank, CA 91520

Stanley J. Wilcox
E.I. DuPont de Neumours & Co.
Textile Fibers Dept.
Bldg 702
Chestnut Run
Wilmington, DE 19707

Raymond Wong
Dexter-Hysol
Aerospace & Ind. Products Div.
2850 Willow Pass Road
P.O. Box 312
Pittsburg, CA 94565

NBS Observers:

Ray G. Kammer
Deputy Director
Administration Bldg.,
Room A1134
Gaithersburg, MD 20899

Lyle H. Schwartz
Director, Institute for
Materials Science & Eng.
Materials Bldg., Room B309
Gaithersburg, MD 20899

Leslie E. Smith, Chief
Shu-Sing Chang
Brian Dickens
Bruno Fanconi
Charles C. Han
Donald Hunston
Fred I. Mopsik
Darrell H. Reneker
John A. Tesk
Wen-li Wu
Polymers Division
Polymer Bldg.
Gaithersburg, MD 20899

APPENDIX II: QUESTIONNAIRES

QUESTIONNAIRE 1

INDUSTRY WORKSHOP ON COMPOSITE PROCESSING

Survey of Processing Methods

Are you a supplier or user _____

What industry sector (sectors) can you respond for

In the following list please indicate which processing methods you feel will be important to your industries or the industries you supply. Consider the time frame of 5 to 15 year. Please add any additional techniques we have not included even if you do not select them as important to the industries you know.

Methods	Selected	Industry (ies)
Pultrusion	_____	_____
Interleaved yarn preparation and processing	_____	_____
Resin coated fiber preparation and processing	_____	_____
Autoclave molding	_____	_____
Powder molding	_____	_____
Thermoforming	_____	_____
SMC forming	_____	_____
Resin transfer molding	_____	_____
Reactive transfer molding	_____	_____
Injection molding	_____	_____
Reactive injection molding	_____	_____
Compression molding	_____	_____
Vacuum assisted, matched metal-molding	_____	_____
3-D Weaving/Braiding	_____	_____
Filament winding	_____	_____
High temperature processing	_____	_____
Alternative sources of heat, i.e., microwave, dielectric, ultrasonic heating	_____	_____
Focussed/diffused heating	_____	_____
_____	_____	_____
_____	_____	_____
_____	_____	_____
_____	_____	_____

QUESTIONNAIRE 2

INDUSTRY WORKSHOP ON COMPOSITE PROCESSING

Priorities for Processing Methods

Are you a supplier or user _____

What industry sector (sectors) can you respond for

Based on your knowledge and the discussions at this Workshop, please indicate your opinions as to the order of priorities in the processing techniques important to your industries or the industries you supply. Start with 1 for the most important and go up through as many techniques as appropriate. Feel free to rate more than one method with equal priority and to add any comments or explanations that you think would be useful.

Methods	Ranking	Selected Industry(ies)
Pultrusion	_____	_____
Extrusion	_____	_____
Interleaved yarn preparation and processing	_____	_____
Commingled fiber processing	_____	_____
Resin coated fiber preparation and processing	_____	_____
Autoclave molding	_____	_____
Powder molding	_____	_____
Thermoforming	_____	_____
Superforming	_____	_____
SMC forming	_____	_____
Long fiber molding	_____	_____
Short fiber molding	_____	_____
Resin transfer molding	_____	_____
Reactive transfer molding	_____	_____
Injection molding	_____	_____
Reactive injection molding	_____	_____
Compression molding	_____	_____
High precision molding	_____	_____
Vacuum molding	_____	_____
Vacuum assisted, matched metal-molding	_____	_____
3-D Weaving/Braiding	_____	_____
Filament winding	_____	_____

Tape laying and placement	_____	_____
High temperature processing	_____	_____
Alternative sources of heat, i.e., microwave, dielectric, ultrasonic heating	_____	_____
Focussed/diffused heating	_____	_____
Liquid crystalline/rigid rod polymer processing	_____	_____
Molecular composite processing	_____	_____
Sequential processing	_____	_____
Precompaction/Densification	_____	_____
Adhesive bonding	_____	_____
Fastening method	_____	_____
Powder impregnation of roving	_____	_____
RIM pultrusion of thermoplastics	_____	_____

QUESTIONNAIRE 3

INDUSTRY WORKSHOP ON COMPOSITE PROCESSING

Survey of scientific and technical problems

The following list includes scientific and technical problem areas that have been suggested. Please add any additional items that you think are important even if they are not a concern for your particular industries. Time frame is again 5 to 15 years.

Next mark those items which are relevant to your industry. If the item is "primarily associated" with one of the processing methods you ranked as important on the previous page, please indicate this.

Problems and Needs	important	specific to proc. method
Materials Properties		
Flow behavior	_____	_____
Crystallization	_____	_____
Phase separation	_____	_____
Reaction kinetics	_____	_____
Heat transfer and thermal conductivity	_____	_____
Data validation/data base system	_____	_____
Automated Process Control - Resin		
Flow	_____	_____
Phase separation	_____	_____
Crystallinity	_____	_____
Temperature profile & gradients	_____	_____
Fiber alignment and Control	_____	_____
Fast curing	_____	_____
Uniform curing	_____	_____
Better heat transfer	_____	_____
High temperature processing and reactions	_____	_____
Adhesion and fiber/matrix interface	_____	_____
Toughening mechanism	_____	_____
Fiber damage	_____	_____
Geometry control	_____	_____
_____	_____	_____
_____	_____	_____
_____	_____	_____
_____	_____	_____

U.S. DEPT. OF COMM. BIBLIOGRAPHIC DATA SHEET <i>(See instructions)</i>	1. PUBLICATION OR REPORT NO. NBSIR 87-3686	2. Performing Organ. Report No.	3. Publication Date FEBRUARY 1988
4. TITLE AND SUBTITLE <p style="text-align: center;">Industry Workshop on Polymer Composite Processing</p>			
5. AUTHOR(S) Peter Beardmore and Donald Hunston			
6. PERFORMING ORGANIZATION <i>(If joint or other than NBS, see instructions)</i> NATIONAL BUREAU OF STANDARDS DEPARTMENT OF COMMERCE WASHINGTON, D.C. 20234		7. Contract/Grant No.	8. Type of Report & Period Covered
9. SPONSORING ORGANIZATION NAME AND COMPLETE ADDRESS <i>(Street, City, State, ZIP)</i>			
10. SUPPLEMENTARY NOTES <input type="checkbox"/> Document describes a computer program; SF-185, FIPS Software Summary, is attached.			
11. ABSTRACT <i>(A 200-word or less factual summary of most significant information. If document includes a significant bibliography or literature survey, mention it here)</i> <p>This report describes the proceedings of an Industry Workshop held at the National Bureau of Standards on October 7, 1987. The Workshop sought to facilitate the expanded use of polymer composites by analyzing the urgent need for improved processing. The Workshop goals were to identify the most promising processing methods for the future and the critical barriers to their implementation. The attendees represent 23 different companies including composite users, suppliers, and fabricators. Five processing methods were selected as most important for the future: pressure molding, transfer molding, filament winding, thermoforming, pultrusion. In addition, two technologies that complement processing were also chosen as very important: resin coating of fibers; alternate sources of energy input. The Workshop concluded that the most critical barriers to implementation of improved processing are inadequate understanding of: resin flow and fiber orientation; temperature gradients and heat flow; fiber-matrix interface; data validation, test standardization; morphology control; surface quality, dimensional tolerances. Increased knowledge in these areas is needed to implement process control and automation which the Workshop felt were keys to more rapid, reliable, and cost effective processing.</p>			
12. KEY WORDS <i>(Six to twelve entries; alphabetical order; capitalize only proper names; and separate key words by semicolons)</i> Autoclave molding; automation; composites; compression molding; filament winding; polymer; process control; processing; pultrusion; thermoforming; transfer molding			
13. AVAILABILITY <input checked="" type="checkbox"/> Unlimited <input type="checkbox"/> For Official Distribution. Do Not Release to NTIS <input type="checkbox"/> Order From Superintendent of Documents, U.S. Government Printing Office, Washington, D.C. 20402. <input checked="" type="checkbox"/> Order From National Technical Information Service (NTIS), Springfield, VA. 22161		14. NO. OF PRINTED PAGES <p style="text-align: center;">44</p>	15. Price <p style="text-align: center;">\$11.95</p>



