

NAT. INST. OF STAND. & TECH. R.I.C.



A11104 062486

NATIONAL INSTITUTE OF STANDARDS &
TECHNOLOGY
Research Information Center
Gaithersburg, MD 20899 /

NBS
PUBLICATIONS

Institute for Materials Science and Engineering

A11102 715805

METALLURGY

NAS-NRC
Assessment Panel
January 21-22, 1988

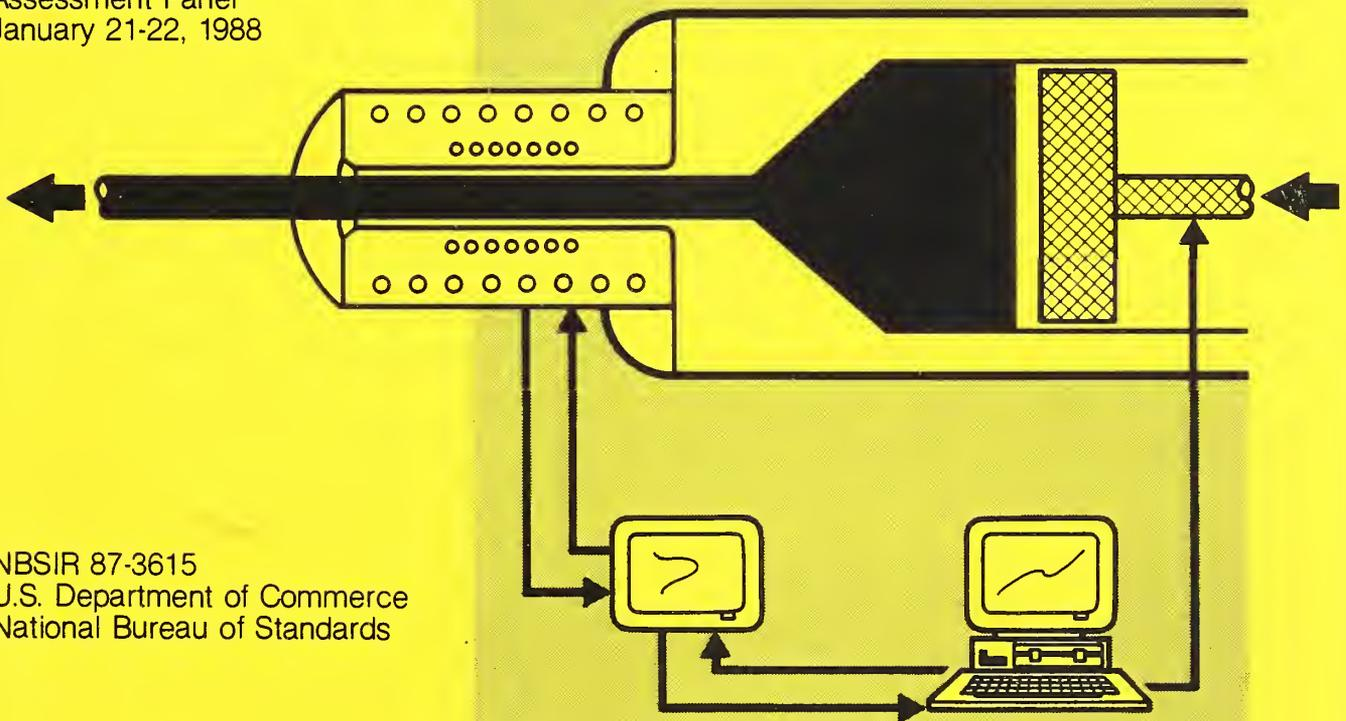

NBSIR 87-3615
U.S. Department of Commerce
National Bureau of Standards

Technical Activities 1987

QC
100
.U56
87-3615
1987
C.2

Institute for Materials Science and Engineering

METALLURGY

E.N. Pugh, Chief
J.H. Smith, Deputy

Research Information Center
National Bureau of Standards
Gaithersburg, Maryland 20899

NBSC
QC100
.456
NO. 87-3615
1987
C2

NAS-NRC
Assessment Panel
January 21-22, 1988

NBSIR 87-3615
U.S. Department of Commerce
National Bureau of Standards

Technical Activities 1987

METALLURGY DIVISION

CHIEF

E. Neville Pugh
Phone: (301) 975-5960

DEPUTY CHIEF

John H. Smith
Phone: (301) 975-5961

GROUP LEADERS

Metallurgical Processing
John R. Manning
Phone: (301) 975-6157

Corrosion and Wear
Arthur W. Ruff
Phone: (301) 975-6010

Metallurgical Structure
John B. Clark
Phone: (301) 975-6040

Electrodeposition
David S. Lashmore
Phone: (301) 975-6405

Nondestructive Characterization
Haydn N. G. Wadley
Phone: (301) 975-6140

Magnetic Materials
Lawrence H. Bennett
Phone: (301) 975-5966

ABSTRACT

This report summarizes the FY 1987 activities of the Metallurgy Division of the National Bureau of Standards. The research centers upon the structure-processing-properties relations of metals and alloys and on the methods of their measurement. The activities also include the generation and evaluation of critical materials data. Efforts comprise studies of metallurgical processing, corrosion and wear, chemical metallurgy, electrodeposition, nondestructive characterization and magnetic materials.

The work described also includes four cooperative programs with American professional societies and industry: the ASM INTERNATIONAL (ASM) - NBS Alloy Phase Diagram Program, the National Association of Corrosion Engineers (NACE) - NBS Corrosion Data Program, the American Iron and Steel Institute (AISI) - NBS Steel Sensor Program, and the Aluminum Association - NBS Temperature Sensor Program.

Work in support of other government agencies includes a major program to assist the Nuclear Regulatory Commission in addressing the critical national problem of disposing of high level nuclear waste in geologic repositories.

The scientific publications, committee participation, and other professional interactions of the 72 full-time and part-time permanent members of the Metallurgy Division and its 40 guest researchers are identified.

TABLE OF CONTENTS

| | <u>PAGE</u> |
|---|-------------|
| OVERVIEW | 1 |
| METALLURGY DIVISION | |
| ORGANIZATION CHART | 5 |
| RESEARCH STAFF | 6 |
| TECHNICAL ACTIVITIES | |
| Metallurgical Processing | 13 |
| Corrosion and Wear | 25 |
| Metallurgical Structure | 39 |
| Electrodeposition | 43 |
| Nondestructive Characterization | 57 |
| Magnetic Materials | 75 |
| OUTPUTS/INTERACTIONS | |
| Recent Publications | 79 |
| Industrial and Academic Interactions | 91 |
| Technical/Professional Committee Leadership Activities | 97 |
| External Recognition and Awards | 102 |
| APPENDIX | |
| Organizational Chart National Bureau of Standards | A1 |
| Organizational Chart Institute for Materials Science and Engineering | A2 |

OVERVIEW

METALLURGY DIVISION (420)

E. Neville Pugh, Chief
John H. Smith, Deputy Chief
June Toms, Secretary

In keeping with the Bureau's traditional role, the Metallurgy Division continues to generate measurement methods, critical materials data and standards to support U.S. industry, government and universities. In the area of measurement science, work on process sensors is leading to more direct interaction with industry and to a growing activity in intelligent materials processing. The Division's research programs support our measurement activities and, in addition, are moving increasingly to address the science base underlying both traditional and new materials technologies, a trend which is also leading to more direct interaction with industry. Our involvement with other government agencies also continues to grow and, in particular, the Division is providing technical assistance in several critical areas, each closely related to our specific research expertise. These diverse activities are summarized here and described in more detail in the narratives of the Division's six groups.

The work on process sensors was highlighted by the successful testing of a prototype eddy current device for determining the internal temperature of aluminum during extrusion. This activity, carried out in the Nondestructive Characterization Group in collaboration with the Aluminum Association, led to tests in an industrial processing plant. A modified version of this sensor has been used to measure density in situ during hot-isostatic pressing (HIPing) of several materials including titanium-aluminide intermetallic alloys and high T_c superconductors. In the same Group, the use of ultrasonic time of flight tomography is being extended to the determination of the position of the liquid-solid interface in partially solidified material, a program being carried out with the American Iron and Steel Institute. In the Metallurgical Processing Group, a consortium has been established with several companies to develop sensors to measure powder size and distribution in real time during the production of powders in our high pressure inert gas atomizer. This program also involves modeling of the atomization process and is aimed ultimately at automated control of the process.

Metal matrix composites represent an important emerging technology in which we have mounted a significant effort. The performance of such composites is critically dependent on the mechanical properties of the interface between the matrix and the reinforcing phase, and our studies have focussed on this factor, particularly in composites consisting of SiC fibers in an Al alloy matrix. Several Groups have interacted in this effort. In the Nondestructive Characterization Group, a technique has been perfected to prepare a sample consisting of an Al monocrystal containing a single SiC

fiber. This sample has permitted fundamental studies of the mechanical properties of the interface using acoustic emission techniques and has been used for ultrasonic studies of "leaky" waves in the interface region to investigate the perfection of the interface. Thermodynamic modeling of stresses generated by interdiffusion at the interfaces are being conducted by the Metallurgical Processing Group. Another unusual approach being pursued is to electrodeposit the Al alloy onto the fiber, and thus the Electrodeposition Group is playing a lead role. In addition to investigating the properties of electrodeposited Al alloys, their activities include modeling of the alloy deposition process on moving fibers, and studies of the feasibility of producing compositionally graded alloys to minimize interfacial stresses.

Data programs continued to be an important component of the Division's activities in FY87. In the Alloy phase Diagram Data Program, set up cooperatively with the ASM International to provide critically evaluated phase diagrams, the year was highlighted by the publication of a two volume compendium of evaluated binary diagrams which updates Hansen's classical compilation. In addition, a relational database of the critical data for nearly 1600 diagrams is ready for on-line search and is being transferred to ASM INTERNATIONAL. The NACE-NBS Corrosion Data Center continues as a focal point of corrosion data to characterize corrosion performance of engineering materials over a wide variety of environments and exposure conditions. Programming of NACE survey data on nonmetals has been completed and resulting software is being marketed by NACE as CORSUR Corrosion Data Software. With assistance from the Center for Applied Mathematics, PC software has been developed utilizing the stability diagram programs (Pourbaix diagrams) originally created at the University of Florida to study corrosion thermodynamics. A Tribology Data Program has been established with joint sponsorship of the Department of Energy, the American Society of Mechanical Engineers, and the American Society of Lubrication Engineers. Abrasive wear coefficients have been evaluated for a group of frequently used metals under standard wear test conditions and assembled into a data base for use in the PC based Tribology and Information System (ACTIS).

A broad range of activities involving other government agencies was conducted in FY87, some in support of our basic research programs and others which provide technical support to the agencies in areas of our expertise. The former is exemplified by studies in the Metallurgical Processing Group of interfaces for application to metal matrix composites and studies of stress effects on alloy coarsening funded at NBS by the Office of Naval Research. A new program on high temperature alloys and intermetallics is being supported by the Defense Advanced Research Projects Agency. Work on powder processing of rapidly solidified alloys was funded during the past year by the Naval Air Development Center. An example of technical support of another agency is the effort in the Corrosion Group to assist the Nuclear Regulatory Commission in the critical national problem of developing geologic repositories for high level nuclear waste. Pitting and stress corrosion cracking are major processes which threaten the integrity of the metallic waste containers, and these phenomena have been central to the research interests of the Corrosion Group for some years. Another example of our research expertise providing

direct assistance has been in the application of advanced electrodeposition techniques to the development of wear-resistant chromium coatings for the Bureau of Engraving and Printing to be used in currency printing plates.

Our staff and their areas of expertise are given in the following pages. There were 72 full-time and part-time permanent people. In addition, there were 40 guest researchers and research associates in residence during the past year who collaborated with Division scientists.



National Bureau of Standards
Institute for Materials
Science and Engineering

450

**METALLURGY
DIVISION**

Division Chief: Dr. E. N. Pugh, x5960
Deputy Chief: Dr. J. H. Smith, x5961
Secretary: Mrs. L. J. Tams, x5963

ADMINISTRATIVE OFFICE

Mrs. M. L. Slosser, x5962
Mrs. S. L. Neill, x5964

INSTITUTE SCIENTIST

Dr. J. W. Cahn, x5664

MAGNETIC MATERIALS

Group Leader: Dr. L. H. Bennett, x5966
Secretary: Mrs. J. M. Hill, x5965
Mathews, D. E., Mr.
Shull, R. D., Dr.
Swarzendruber, J. L., Dr.
Students
Chen, T. A.
Tse, C.
Guest Scientist
Atzmony, U., Dr.

METALLURGICAL PROCESSING

Group Leader: Dr. J. R. Manning, x6157
Secretary: Mrs. S. L. Caudore, x6154
Biancaniello, F. S., Mr.
Boettlinger, W. J., Dr.
Cortell, S. R., Dr.
Haudwetter, C. A., Dr.
Parke, R. L., Mr.
Roder, S. D., Dr.
Schaefer, R. J., Dr.
Voorhees, P. W., Dr.
Students
Carrick, D. G.
Dang, D. T.
Ferenig, D. L.
Huber, D. M.
Guest Scientists
Bendersky, L. A., Dr.
Lee, D. J., Dr.
Shochman, D., Dr.
Rhee, W. H., Dr.
Yoon, D. N., Dr.
Consultant
Sekerka, R. F., Dr.

METALLURGICAL STRUCTURE

Group Leader: Dr. J. B. Clark, x6040
Secretary: Mrs. R. V. Drew, x6038
Clerk-Typist: Ms. S. L. Becker, x6039
Burton, B. P., Dr.
Danko, G. A., Mr.
Hayes, R. M., Mrs.
McAlister, A. J., Dr.
Shapiro, A. J., Dr.
Guest Scientist
Kattner, U., Dr.
Research Associates
Lilly, L., Ms.
Sirofchuck, C. E., Ms.

NONDESTRUCTIVE CHARACTERIZATION

Group Leader: Dr. H. N. G. Wadley, x6140
Secretary: Mrs. A. L. Nashwinter, x6139
Clough, R. B., Dr.
Johnson, W. L., Dr.
Kahn, A. H., Dr.
Linzer, M., Dr.
Mauer, F. A., Mr.
Norton, S. J., Dr.
Picture, D. J., Mr.
Simmons, J. A., Dr.
Students
Cavedo, R. F.
Quinones, R. P.
Guest Scientists
Gefen, Y., Dr.
Krasicka, E., Dr.
Rosen, M., Dr.
Semhira, A. N., Dr.
Research Associates
Cook, J. R., Dr.
Mester, M., Mr.
Rogers, C. D., Mr.

ELECTRODEPOSITION

Group Leader: Dr. D. S. Lashmore, x6405
Secretary: M. M. Wykes, x6400
Beauchamp, C. R., Mr.
Brown, H. J., Mrs.
Claggett, S. A., Mrs.
Johnson, C. E., Mr.
Kelley, D. R., Mr.
Mullen, J. L., Mr.
Nottingham, H. B., Ms.
Sharpless, P. N., Mr.
Stafford, G. R., Mr.
Students
Bondia, D. J.
Oberle, R. B.
Stewart, G. D.
Van Vechten, T. C.
Guest Scientist
Grushko, B., Dr.
Opburn, F., Mr.
Wheeler, N., Mrs.
Research Associate
Yahalom, J., Dr.

CORROSION AND WEAR

CORROSION

Group Leader: Dr. A. W. Rufin, x6010
Secretary: Mrs. N. J. Wilkin, x6020
Corrosion
Anderson, D. B., Mr.
Bertocci, U., Dr.
Escalante, E., Mr.
Fink, J. L., Mr.
Flanagan, C. D., Mrs.
Hall, D. E., Dr.
Harris, J. F., Ms.
Harrison, S. A., Mr.
Interrante, C. G., Dr.
Lohr, D., Mrs.
Ricker, R. E., Dr.
Rispi, J. S., Mrs.
Slundt, M. R., Mr.
Guest Scientist
Cassagne, T., Mr.
Research Associates
Karras, P., Mr.
Sturrock, C., Mr.

WEAR

Group Leader: A. W. Rufin, x6010
Wear
Boyer, P. A., Mr.
Fraker, A. C., Dr.
Harris, J. S., Ms.
Ives, E. K., Mr.
Peterson, M. B., Mr.
Whitenton, E. P., Mr.
Guest Scientist
Lump, I. G., Dr.
Sung, P., Dr.
Research Associates
Macia, J. M., Ms.
Swanson, P. A., Dr.

RESEARCH STAFF

Metallurgical Processing Group

- Biancaniello, Francis S.
- o Inert gas atomization and metal powder processing
 - o Special alloy and quasicrystal preparation
 - o Melt-spinning rapid solidification
- Boettinger, William J.
- o High temperature alloys/intermetallics
 - o Rapid solidification
 - o Relation of alloy microstructures to processing conditions
- Coriell, Sam R.
- o Modeling of solidification processes
 - o Interface stability
 - o Convection and alloy segregation during solidification
- Handwerker, Carol A.
- o Interface studies
 - o Diffusion-induced grain boundary migration
 - o Metal matrix composites
- Hardy, Stephen C.
- o Alloy coarsening
 - o Surface tension measurements
 - o Interface segregation
- Manning, John R.
- o Metallurgical processing
 - o Diffusion kinetics
 - o Interface migration
- Ridder, Stephen D.
- o Inert gas atomization
 - o Microparticle rapid solidification
 - o Solidification dynamics
- Schaefer, Robert J.
- o Solidification processes
 - o Quasicrystals/intermetallics
 - o Electron beam rapid solidification
- Voorhees, Peter W.
- o Coarsening phenomena
 - o Elastic effects during phase transformations
 - o Anisotropic interface effects

Corrosion and Wear Group

- Anderson, David B.
- o Industrial corrosion testing
 - o Corrosion data evaluation
 - o Corrosion database development
 - o Expert systems for corrosion control
- Bertocci, Ugo
- o Electrochemical measurements
 - o Computer modeling
 - o Passivity and pitting
- Blau, Peter J.
- o Friction and wear transitions
 - o Wear microstructure relations
 - o Microindentation and scratch hardness
- Escalante, Edward
- o Underground corrosion
 - o Corrosion in concrete
 - o Corrosion rate measurements
- Fraker, Anna C.
- o Titanium alloys
 - o Corrosion processes
 - o Transmission electron microscopy
 - o Surgical implant metals
- Hall, Dale E.
- o Electrochemistry
 - o Corrosion of advanced materials
- Harris, Jonice S.
- o Scanning electron microscopy
 - o Corrosion measurements
 - o Wear and friction properties
- Harrison, Steven A.
- o Computer systems programming
 - o Software engineering
 - o Laboratory automation
- Interrante, Charles G.
- o Hydrogen embrittlement
 - o Nuclear waste disposal
 - o Environmental testing
 - o Welding metallurgy
- Ives, Lewis K.
- o Wear of materials
 - o Transmission electron microscopy
 - o Mechanical properties
- Peterson, Marshall B.
- o Wear of materials
 - o Solid film lubricants
 - o Mechanical behavior
- Polvani, Robert S.
- o Mechanical behavior
 - o High temperature strengthening mechanisms
 - o Microindentation measurements
 - o Dimensional instability behavior

- Ricker, Richard E.
- o Environmental induced fracture
 - o Scanning and transmission electron microscopy
 - o Corrosion and electrochemistry
- Ruff, Arthur W.
- o Wear and friction
 - o Microstructure effects
 - o Mechanical behavior
 - o Microscopy
- Smith, John H.
- o Mechanical properties of materials
 - o Fracture of materials
 - o Structural integrity analysis
- Stoudt, Mark R.
- o Physical metallurgy
 - o Corrosion engineering
 - o Environmentally induced fracture
- Ugiansky, Gilbert M.
- o Management of computer database for corrosion data
 - o Corrosion data evaluation and dissemination
 - o Localized corrosion
 - o Slow strain rate stress corrosion testing
- Van Orden, Ann C.
- o Marine corrosion
 - o Localized corrosion
 - o Dealloying

Metallurgical Structure Group

- Burton, Benjamin P.
- o Thermodynamic modeling of alloy phase diagrams
 - o Order-disorder and phase separation in alloy systems
 - o Associate editor, BAPD
 - o Computer database development
 - o Ab-initio calculation of phase diagrams
- Clark, J. Beverly
- o Precipitation processes in alloys
 - o Evaluation of magnesium-base binary phase diagrams
 - o Editor, Bulletin of Alloy Phase Diagrams
- McAlister, Archie J.
- o Differential thermal analysis
 - o Equilibrium phase diagrams
 - o Enthalpy and kinetics of metastable phase transformations
 - o Evaluation of binary and higher order phase diagram data

Shapiro, Alexander J.

- o Analytical electron microscopy
- o X-ray microanalysis
- o Image analysis
- o Transmission electron microscopy

Electrodeposition Group

Beauchamp, Carlos R.

- o Computer simulation of electrodeposition processes on moving fibers
- o Electrochemical measurements of kinetic parameters

Brown, Henrietta J.

- o Coating thickness SRM development
- o Simultaneous thickness electropotential (STEP) SRM development

Claggett, Sandra W.

- o Scanning electron microscopy
- o Metallographic specimen preparation
- o General electroplating

Johnson, Christian E.

- o Ultra-black coatings
- o Electroless deposition processes
- o Metallic glass alloy deposition
- o Microhardness SRM research
- o Chromium deposition
- o Pulsed alloy deposition

Kelley, David R.

- o Microhardness SRM development
- o Dye penetrant SRM development
- o Precious metal electrodeposition
- o Plating on aluminum

Lashmore, David R.

- o Electrochemical mechanisms of coating processes
- o Pulsed alloy deposition
- o Composition modulated alloy deposition
- o Properties and structure of electrodeposited coatings
- o Amorphous alloys
- o Transmission electron microscopes
- o Metal matrix composites

Mullen, Jasper L.

- o Development of automated hardness testing
- o Electrochemical measurements for determining metal corrosion
- o Analytical spectroscopy

Stafford, Gery R.

- o Electrocatalysis
- o Electrochemical transients
- o Electrodeposition
- o Molten salt electrochemistry

Nondestructive Characterization Group

Clough, Roger B.

- o Acoustic emission
- o Mechanical properties
- o Surface modification

Kahn, Arnold H.

- o Eddy current modeling
- o Electromagnetic theory
- o Solid state physics

Johnson, Ward L.

- o Ultrasonics
- o Solid state physics
- o Point defects in metals & semiconductors

Linzer, Melvin

- o Ultrasonic imaging
- o Acoustic emission
- o Ultrasonic scattering

Mauer, Floyd A.

- o Ultrasonic tomography
- o X-ray diffraction
- o Ultrasound-microstructure relations

Norton, Stephen J.

- o Ultrasonic and NMR imaging
- o Inverse modeling
- o Mossbauer imaging

Pitchure, David J.

- o Digital electronics
- o Ultrasonic instruments
- o High temperature measurements

Simmons, John A.

- o Dislocation theory
- o Acoustic emission
- o Inverse modeling

Wadley, Haydn N.G.

- o Dislocations and fracture
- o Acoustic emission
- o Ultrasonics

Magnetic Materials Group

Bennett, Lawrence, H.

- o Magnetic measurements
- o Alloy phase stability
- o Hyperfine fields

Shull, Robert D.

- o Magnetic susceptibility
- o Mossbauer effect
- o X-ray and neutron diffraction
- o Differential thermal analysis
- o Scanning electron microscopy

Swartzendruber, Lydon J.

- o Magnetic susceptibility
- o Magnetic methods, NDE
- o Gamma-ray resonance spectroscopy
- o Iron binary phase diagrams

The properties of alloys depend on their processing history. Proper control of processing conditions allows tailoring of alloys to produce microstructures, compositions, and properties needed for particular applications. The NBS work on metallurgical processing has as its objective the development of measurements, measurement methods, and predictive models to allow improved control of metallurgical processes. The resulting guidelines, models, and control techniques then can be used to produce cost savings, increased reliability, and higher performance in final products.

An important aspect of this effort is the establishment of strong interactions with industry, universities, and other Government agencies. During the past year a new NBS-industry consortium was formed to fund and perform research on automated processing of rapidly solidified metal powders produced by high pressure inert gas atomization. The objective of this consortium work is to develop particle size measurement techniques that can provide immediate feedback to the atomization system, thus providing control of powder size distributions while the powder is being produced. Initial industrial participants in this consortium are Crucible Materials, General Electric, and Hoeganaes.

In other interactions, collaboration continues with the steel industry on problems concerning continuous casting. In cases where NBS has special processing facilities, these are made available to non-NBS scientists. For example, visiting scientists from industry and universities come to NBS to participate in the preparation of special rapidly solidified alloys. Interface studies for application to metal matrix composites and studies of stress effects on alloy coarsening are funded at NBS by the Office of Naval Research. A new program on high temperature alloys and intermetallics is being supported by the Defense Advanced Research Projects Agency. Work on powder processing of rapidly solidified alloys was funded during the past year by the Naval Air Development Center. Measurements and modeling of convection during directional solidification and of coarsening in liquid-solid mixtures are being sponsored by the National Aeronautics and Space Administration.

The emphasis of the work is on (1) new science and technology, such as the recently started work on interface processes in metal matrix composites and on non-equilibrium processing paths for intermetallics; (2) recently discovered phenomena, such as quasicrystals and unexpected stress effects at solid interfaces, both of which were discovered as a result of special metallurgical processing work at NBS; and (3) measurements and predictive models, such as in work on automated processing for atomization and in controlled solidification studies.

FY 87 Significant Accomplishments

- o Conditions were discovered which greatly increase the stability against precipitate coarsening of precipitation-strengthened aluminum-iron-base powder alloys. This stability depends on formation of phase sequences involving an amorphous phase, similar to sequences previously encountered in NBS quasicrystal studies. This result provides the

prospect that bulk parts can be made from these powder alloys without loss of the useful properties imparted by their original rapid solidification.

- o Experiments were performed in which alternating deposition and dissolution reactions were produced by diffusion-generated stresses and other driving forces present at originally planar Mo(solid)-Ni(liquid) interfaces. This result demonstrated the strong effect that stresses produced by diffusion across interfaces, such as occur in metal matrix composites, can have in destabilizing these interfaces.
- o Effects of atomization conditions on average powder particle size in Sn alloys were measured during test runs in the recently-commissioned NBS high pressure inert gas atomization system. Typically, ten-pound powder batches with average particle diameters as small as 20 micrometers were produced under known, controlled conditions. In addition, successful powder production runs were made with Al-base and Cu-base alloys in this system.
- o Coarsening of solid particles in a Pb-Sn solid-liquid mixture was quantitatively measured at high volume fraction solid and shown to follow the trend predicted by coarsening theories recently developed at NBS. This work provided the first systematic experimental test of precipitate coarsening theories for the high volume fraction regime.
- o Growth patterns for Al-Li-Cu quasicrystals were analyzed and found to have fastest growth along the five-fold icosahedral axes. This contrasts with previous results on Al-Mn where the fastest growth was along the three-fold icosahedral axes.
- o The conditions for the formation of various ordered phases by rapid solidification in the NiAl-NiTi high temperature intermetallic system were determined. The B2 phase was found to form at some compositions where the L2₁ phase was stable, permitting the formation of special two-phase microstructures important for high temperature creep properties. This investigation required the use of the thermodynamics of second order phase transformations.

Physical Metallurgy and Processing of Advanced Alloys

W. J. Boettinger, R. J. Schaefer, S. D. Ridder, S. R. Coriell,
F. S. Biancaniello, J. W. Cahn, L. A. Bendersky*, and D. Shechtman**

* Guest Scientist - Johns Hopkins University

** Guest Scientist - Johns Hopkins University and Technion, Haifa, Israel

The development of new alloys with improved strength, lower density, and/or higher operating temperatures often proceeds by incremental modifications of existing alloys. The research reported here, however, follows a somewhat different approach, being more concerned with new processing methods and classes of alloys not normally employed in conventional metallurgical practice. These alloys and processing methods in many cases produce large

improvements over properties of conventional materials. Scientific information developed in this work provides guidelines which can be used in applying these new alloys and processes to specific product applications.

Rapid solidification followed by controlled thermomechanical processing is being used to produce microstructures unobtainable by conventional casting and forging. Focus on specific alloy systems, while necessary for experimental research, is aimed at obtaining general strategies for alloy processing and directing theoretical efforts to issues of technological importance. New work has been initiated into the processing of alloys based on intermetallic compounds. Also, ideas generated in the NBS studies of quasicrystals have been applied to understand the phases formed in precipitation-strengthened aluminum alloys.

Intermetallic High Temperature Alloys - Because of their high melting temperatures and low densities, many intermetallic compounds show promise for a generation of advanced alloys which may span the gap between ductile metallic alloys and brittle ceramic materials. Recently the application of rapid solidification and other new processing techniques to intermetallic alloys has stimulated a renewed effort in the development of high temperature intermetallics to replace Ni-base superalloys.

Research on intermetallic compounds is directed toward the examination of processing paths involving metastable phases to produce new and unusual two-phase structures. For example, the formation of ductile second phase particles in intermetallics has the potential of increasing the toughness of these materials. Since equilibrium phase diagrams suggest only limited opportunities for precipitation from supersaturated intermetallic phases by conventional heat treatment, the possibility of extending the range of solubility of intermetallics by rapid solidification is being examined. The possibility of quenching the related disordered form of intermetallic phases is also of interest.

Research has been directed toward four alloy systems, Nb-Al, Nb-Si, Ti-Al, and NiAl-NiTi. The intermetallic compound NbAl₃ has a very limited equilibrium range of composition (<1%). Alloys which are ± 3 atomic percent from the stoichiometric compound were melt spun, but no increase in the range of solubility was found. These preliminary results are being examined from a thermodynamic and kinetic viewpoint and future experiments are being planned using laser surface melting. Research on the other three systems has been published or accepted for publication. "Microstructural Characterization of Rapidly Solidified Nb-Si Alloys" presents interesting microstructures containing fine grain (15-100 nm) mixtures of the intermetallic Nb₅Si₃ and BCC-Nb. The observed microstructures are shown to be consistent with a metastable phase diagram and T₀ curves for the Nb-Si system. "Pathways for Microstructural Development in TiAl," written jointly with J. Graves and J. Perepezko of the University of Wisconsin at Madison, examines the formation of a disordered HCP phase at the TiAl composition by rapid solidification and subsequent ordering to the Ti₃Al structure during solid state cooling as shown in figure 1. Further decomposition of this structure during post solidification heat treatment into alternating plates of Ti₃Al and TiAl demonstrates the different microstructural paths possible with new processing methods. Finally in "Rapid Solidification and Ordering of B2 and L2₁ Phases in the NiAl-NiTi System" evidence is presented for direct

solidification of the B2 phase at compositions where the L₂₁ phase is stable at the liquidus. This extension of the range of homogeneity of the B2 phase results in the formation of L₂₁ precipitates in the B2 matrix after heat treatment, with volume fractions not possible by conventional means. Interestingly, in this system the continuous ordering between the B2 and L₂₁ phase alters the precipitation process in a way which requires an examination of the kinetics of second order phase transformations.

Theory of Microstructure Development - A major advantage of rapid solidification is the increased alloy homogeneity that can be provided by avoiding interdendritic segregation. In order to better understand what conditions lead to the reduction of microsegregation during rapid solidification, a complete theory of dendritic growth was formulated. This theory predicts the dendrite growth velocity, tip radius, and composition as a function of the undercooling below the equilibrium liquidus, which usually occurs in rapid solidification processes. The theory includes corrections to older theories necessary to treat high thermal and solute Peclet numbers common for high growth rate and non-equilibrium interface conditions (solute trapping). The theory predicts a sharp change in dendrite composition and radius as a function of undercooling as shown for a Ag-15wt% Cu alloy in figure 2. This transition is related to the unique microstructures obtained during rapid solidification.

Aluminum-base Alloys Involving Quasicrystals and Related Phases - Aluminum alloys containing large additions (~10%) of elements with limited equilibrium solubility ($\leq 2\%$) form one of the new classes of alloys made possible by rapid solidification. Instead of freezing with large brittle intermetallic phases, these alloys can be processed to contain a fine dispersion (50 nm) of intermetallic phase with resultant improvements in high temperature (340 °C) performance due to the slow microstructural coarsening rate. Research has focused on Al-Fe-Si alloys where the microstructural path from liquid to powders to consolidated bulk material has been studied. While over 20 stable and metastable ferrosilicide phases have been reported in the literature in this system, rapidly solidified alloys contain only two phases in combination with the primary aluminum phase: the first is a BCC phase designated α -(Al,Fe,Si) which is very resistant to coarsening in the aluminum matrix; the second is an amorphous phase with extended short-range order. The relationship between the structures of these two phases has been studied by electron microscopy. The phases can be thought of as different packings of Mackay icosahedra, which are the icosahedral units often used in models of quasicrystal phases. During heat treatment and consolidation of powders the relationship appears to control the nucleation of the BCC phase and thus is directly related to the changes of the microstructure during consolidation.

Other activities involving structural studies of icosahedral quasicrystals have involved Al-Mn and Al-Cu-Li alloys. Structural similarities between Al-Mn quasicrystals and a variety of stable and metastable Al-Mn intermetallic crystalline phases determined using electron diffraction suggest that many of these phases have a structural skeleton of icosahedral units arranged in different stackings. Figure 3 shows a selected area diffraction pattern of the hexagonal (crystalline) μ phase showing pseudo-icosahedral (5-fold) symmetry which results from the oriented icosahedral units within the hexagonal crystal. Dendritic crystals of the icosahedral Al₆Li₃Cu phase over 1 cm in length have been produced by directional solidification. It has been

found that these dendrites have a growth form which differs from that of icosahedral Al-Mn as a result of preferred growth along the 5-fold instead of the 3-fold symmetry axis.

Powder Processing - Inert gas atomization is an important method for the production of rapidly solidified alloy powders. A full scale high-pressure inert gas atomization system has been constructed for the purpose of providing powders of experimental alloys and of investigating and controlling the atomization process to produce desired powder size distributions and microstructures. A consortium of industrial companies, including Crucible Materials, General Electric, and Hoeganaes, has joined in this research effort. To date approximately 20 atomization runs have been performed on alloys with melting points up to 780 °C. In these runs, ten-pound batches of Sn-base, Al-base, or Cu-base alloys have been atomized to produce rapidly solidified powder with average particle diameters as small as 20 micrometers. Modification of the atomizer to permit the installation of a variety of sensors has been completed. These modifications will permit photography of the breakup of the molten metal stream by the high pressure atomizing gas and on-line powder size measurement in the collection system by laser scattering. A schematic of the system is shown in figure 5. The powder size measurements will eventually be used in a feedback control system. Preliminary studies of particle size as a function of gas jet velocity and metal flow rate have suggested that these parameters must be controlled independently.

Studies on the consolidation of powder by hot isostatic pressing (HIPing) are concerned with the microstructural coarsening of the Al-Fe-Si alloys described previously and the development of sensors for real-time monitoring of the density change during consolidation. This latter effort is being performed in collaboration with the Nondestructive Characterization Group of the Metallurgy Division and is described in detail in their section of this annual report.

Controlled Solidification

S. R. Coriell, R. J. Schaefer, and J. R. Manning

In this research, the fluid flow, solute segregation, and interface morphologies which occur during solidification are being studied and techniques for monitoring solidification velocities are being developed. In collaboration with G. B. McFadden and R. F. Boisvert of the NBS Center for Applied Mathematics, R. F. Sekerka of Carnegie-Mellon University, A. A. Wheeler of the University of Bristol, and D. T. J. Hurle of the Royal Signals and Radar Establishment, convection and interface stability during alloy solidification have been analyzed and modelled. The resulting predictive models can be used to guide alloy designers in choosing processing conditions that will provide optimum properties of the solidified materials, for example, in providing homogeneous material needed for electronic applications and in predicting the type of alloy segregation expected during the continuous casting of steel.

Convection and Interface Morphology during Directional Solidification -

During solidification of alloys from the melt, the crystal-melt interface is subject to morphological instability. For directional solidification at constant velocity, a planar crystal-melt interface is stable for sufficiently

low solute concentrations or for sufficiently high temperature gradients. For typical temperature gradients and binary alloy compositions, the interface is stable for low and high solidification velocities, but unstable at intermediate velocities. The morphological stability theory has been extended in current work to the directional solidification of multicomponent alloys [J. Crystal Growth, 82, (1987), 295-302]. It was found that additional solutes enhance instability, but with different weighing factors for each of the solutes. For example, in the Fe-C-S system, sulfur with its low distribution coefficient is more effective in causing instability than carbon with a relatively high distribution coefficient.

Three-dimensional steady-state solutions for nonplanar interface morphologies have been computed numerically by using finite differences. A linear temperature field was assumed, corresponding to the case of equal thermal properties in the crystal and melt, with negligible latent heat release. The solute field in the melt and the unknown crystal-melt interface position were obtained self-consistently. For an aluminum-chromium alloy with a distribution coefficient greater than one, steady state solutions corresponding to two-dimensional bands and three-dimensional hexagonal nodes were obtained, as well as solutions with rectangular interface planforms. For a small range of concentrations, there are two stable steady-state solutions, the node solution and a rectangular solution. For the parameter range of our calculations, two-dimensional and cell-like (rather than node-like) solutions are not stable. These numerical calculations are consistent with the results of weakly nonlinear theory. The weakly nonlinear theory is being extended to allow for nonlinear temperature fields and the effects of anisotropic surface tension. Additional numerical calculations are underway for iron alloys, in particular, the iron-silicon system.

A possible technique for increased control of the directional freezing of binary alloys is the passage of an electrical current through the system comprising crystal and melt phases, and hence across the crystal-melt interface. The passage of an electrical current results in electromigration of the solute, and hence solute redistribution. Joule heating and thermoelectric phenomena, such as the Peltier, Thompson, and Seebeck effects, also occur. In addition, pulsed electrical currents are often used to delineate the morphology of the crystal-melt interface in metals and semiconductors. In order to provide a predictive basis for these techniques, a theoretical study of the effect of electric currents on the solidification process has been begun. A fully time-dependent linear stability analysis for directional solidification of a binary alloy at constant velocity in the presence of an electric field has been carried out. A modified constitutional supercooling criterion for interface stability has been obtained which is valid for a large range of conditions. Under certain conditions, the onset of instability may be oscillatory in time.

Ultrasonic Measurements of Solidification and Crystal Growth in Metals and Semiconductors - The velocity of sound and the density have values that are sufficiently different for liquid as compared to solid phases of metals, alloys, and semiconductors to permit the use of pulse-echo ultrasonic techniques to locate the solid-liquid interface during solidification, crystal growth, and melting. This real-time ultrasonic metallography technique was, in previous NBS work, clearly demonstrated for iron and stainless steel samples. This method will be important to any materials

processing industry in which opaque materials are solidified, since real-time measurements which allow feedback and control can provide both quality control and productivity improvement.

Ultrasonic measurements have now been made on a number of specimens of single-crystal alloy. Specimens were cut, machined, and polished to present different crystallographic orientations to the ultrasonic waves. Both velocity and attenuation measurements have been made. An x-y scanning test bed has been constructed to permit quantitative measurement of echo strength as a function of position on the test specimens.

These scanning tests showed very pronounced directionality effects in echo strength at 5 MHz, at room temperature. For specimens with axial orientation about 15° off the [001] axis, the attenuations in a 10 cm round-trip varied by factors of more than 100 to 1, depending on position in these off-axis specimens. In contrast, some very low attenuation values were obtained for specimens along [001] and [010] as well as [110] axes. Further understanding of these effects and their implications for solid-liquid interface monitoring will require further testing of specimens at different orientations and at elevated temperatures.

Solid State Processes and Alloy Interfaces

J. R. Manning, C. A. Handwerker, S. C. Hardy, P. W. Voorhees, J. W. Cahn, J. D. Lee*, and W. H. Rhee**

* Guest Scientist - Chonnan National University, Kwangju, Korea

** Guest Scientist - Korea Advanced Institute of Science and Technology, Seoul, Korea

Solid state reactions, especially those at interfaces, are critical in determining the properties of a number of materials. Metal matrix composites, surface modified alloys, and alloys undergoing coarsening are examples of materials where significant interface effects occur. Topics that are important in current NBS work in this area include surface energy effects and the effect of stresses generated near interfaces by diffusion processes in solids. It has been found that these stresses and energies can produce surprisingly large deviations from equilibrium concentrations at interfaces, enhance the stability of precipitation-strengthened alloys, and cause unexpected interface roughening.

Thermodynamics and Kinetics of Reactions at Non-Equilibrium Interfaces - At non-equilibrium interfaces new phases can nucleate, diffusion can take place across and along the interface, stresses can be generated by lattice mismatch, and complex dislocation reactions can occur. These processes can produce interface broadening, create interface roughness and dramatically change the properties of the two-phase interface. Because of the practical consequences of these interface reactions, principles governing these processes need to be understood and their importance in controlling interface properties evaluated. Metal matrix composites are prime examples of complex engineering systems where materials are not in thermodynamic equilibrium during initial fabrication, during production of components, or in use.

Resistance of these composites to fracture and crack propagation depends strongly on the degree of bonding, the amount of fiber pull-out, and the structure of the matrix-fiber interface.

Two major features of our current work on non-equilibrium interfaces are: (1) the effect of surface energy variations on heterogeneous nucleation textures, and (2) the effect of stresses produced by interdiffusion across an interface. A thermodynamic theory has been developed which demonstrates that the orientations of crystals nucleating on a planar substrate should depend on the equilibrium shape of the crystal and that minimizing the energy barrier for nucleation leads to the predictions of strong orientation textures that can change abruptly with small changes in the nucleation conditions. For example, modifying the surface energies by small amounts, such as by introducing alloying elements or by small changes in temperature, could have strong effects on interface textures or roughness.

Diffusion at an interface generates large coherency stresses and strains when the lattice parameter is a function of composition. At a solid-solid interface the change in lattice parameter produces a compressive stress on one side of the interface and a tensile stress on the other side, thus creating a stress discontinuity at the interface. Current work shows that the inclusion of this stress discontinuity into the thermodynamic and kinetic equations for diffusion leads to a prediction that the interface compositions and the diffusion profiles are shifted significantly from the unstressed values. Experimental studies of this coherency stress effect are being conducted on interdiffusion in Si-Ge multilayers using x-ray diffraction, TEM, and atom-probe mass spectrometry techniques.

The effects of stresses generated by diffusion at liquid-solid interfaces have also been demonstrated in experiments on Mo single crystals surrounded by molten Ni. During diffusion of Ni into Mo, stresses due to atomic size mismatch between Mo and Ni are generated in the diffusion zone. As a result of these stresses, the originally planar interface between the solid Mo and liquid Ni becomes unstable, forming a sinusoidal interface shape with a wavelength of approximately 5×10^{-5} m, as shown in figure 4. As the amplitude of the perturbation grows, precipitation of the equilibrium Mo-Ni solid solution occurs at the peaks of the interface and dissolution in the valleys. This dissolution-precipitation process produces significant roughening of the interface. Similar interface roughening can occur during fabrication of metal matrix composite materials which are often produced by liquid metal infiltration into a fiber preform.

This interfacial instability is a newly identified phenomenon having broad implications for microstructural stability during processing and use of all classes of materials containing a liquid phase. In particular, it is important to understand how to suppress the instability when, for example, planar composite interfaces are required for mechanical properties. In conjunction with Professor Duk N. Yoon of the Korea Advanced Institute of Science and Technology, NBS Metallurgy Division scientists are developing and experimentally testing general predictive models for the interface morphology changes in solid-liquid systems at elevated temperatures.

Diffusion-Induced Grain Boundary Migration - Grain boundaries in polycrystals, when exposed to a solute source, have been found to migrate,

often away from their centers of curvature, and to form solid solutions in the regions swept by the moving boundaries. Solute diffusion from the free surface into the bulk has also been found to produce new grains of solid solution alloy which nucleate in the original matrix grains in regions which were essentially single crystals before exposure to the solute source. The most important question which has been asked about these two processes is why they occur at all; that is, what is the driving force which couples the nucleation of new grains and the motion of the boundary to diffusion of the solute. A mechanism map describing these phenomena has been derived which contains various diffusion and migration regimes where different driving forces dominate. The features of this map, which are qualitatively consistent with results in Cu-Zn, are being examined in detail in several materials systems.

Alloy Coarsening - Experiments have measured the coarsening kinetics of a two-phase mixture consisting of solid Pb-rich or Sn-rich particles in a eutectic liquid. These experiments are the first such coarsening experiments using a system in which all the materials parameters necessary for a comparison between theory and experiment are known. The experimental scaled particle radius distribution agrees quite well with the theoretically predicted distribution. However, the mixtures are coarsening faster than theory predicts. The cause of the apparent discrepancy in the predicted and measured coarsening rates is currently being investigated.

In conjunction with B. Caroli, C. Caroli, and B. Roulet of the Groupe de Physique des Solides of the University of Paris VII, the morphological stability of a growing spherical particle from a melt including the effects of compositionally generated elastic stresses was investigated. This is the first study of the morphological stability of a solid-liquid interface to employ the thermodynamics of stressed solids to determine the interfacial equilibrium conditions. It was found that elastic stresses can either destabilize or stabilize the growing particle. In some cases, the compositionally generated stresses can destabilize the growing particle to the extent that the critical radius for instability is decreased from 7 to 6 times the critical radius for nucleation.

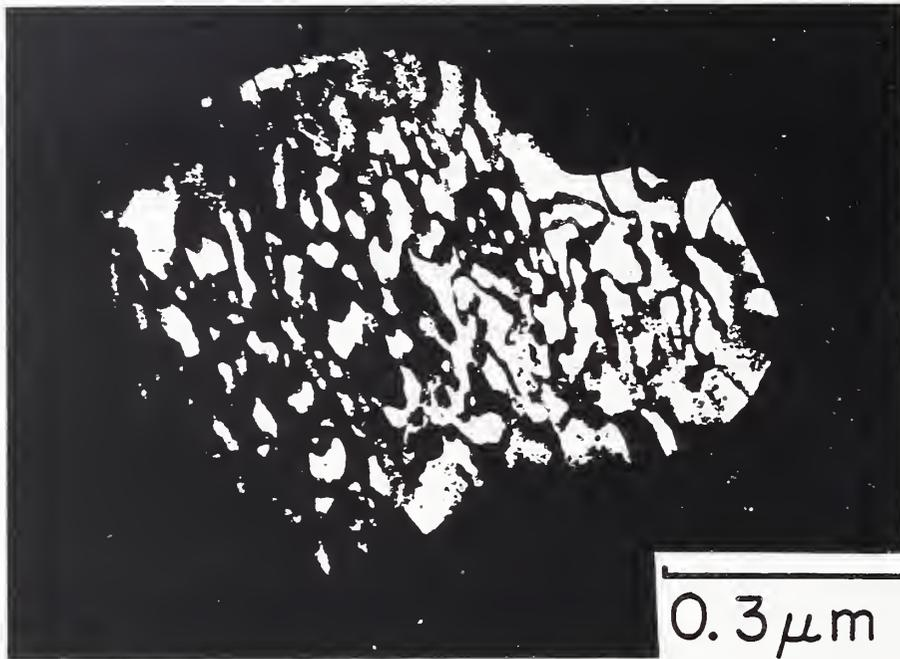

Figure 1. TEM dark field image of the hexagonal phase in melt spun Ti-52 at % Al using a superlattice reflection. The fine antiphase domains prove that the ordering occurred in the solid state and that metastable disordered hexagonal phase formed originally from the melt.

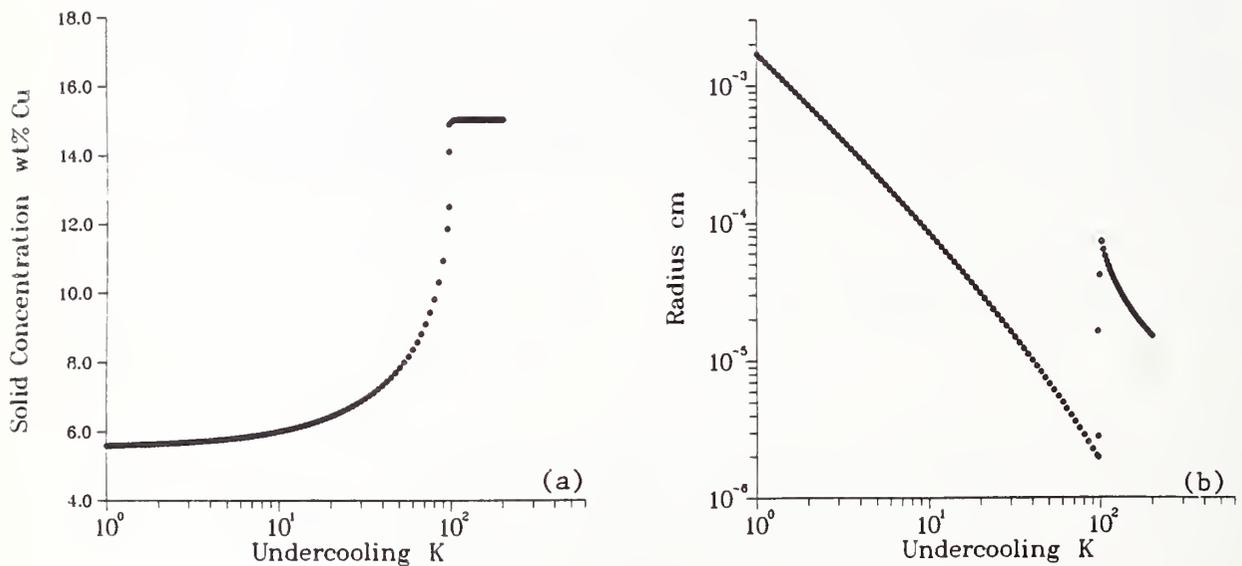

Figure 2. Results of dendritic growth theory for Ag-15 wt% Cu which show (a) the solid composition of the dendrite tip, and (b) the dendrite tip radius for various undercoolings below the liquidus.

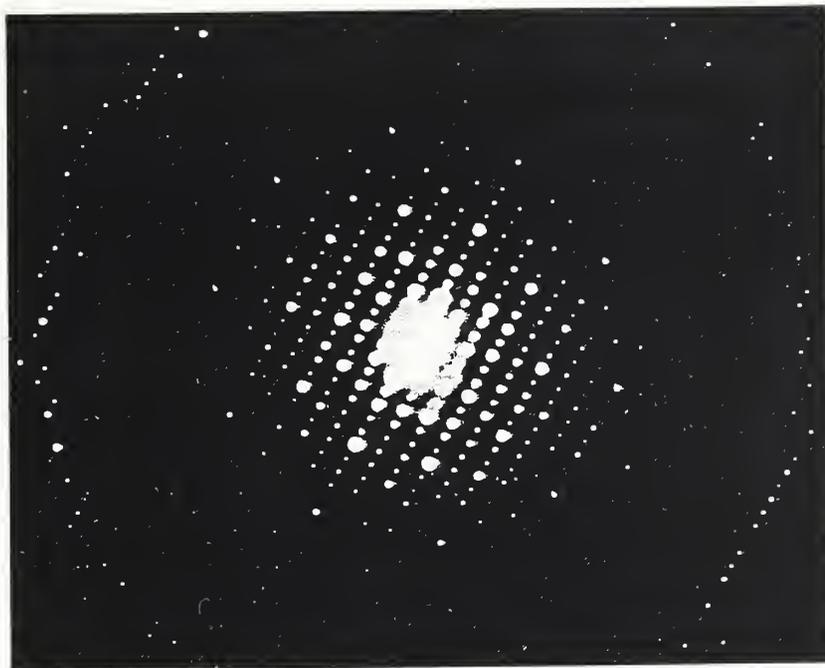

Figure 3. Selected area electron diffraction pattern of the crystalline hexagonal μ -phase in Al-Mn showing pseudo-icosahedral 5-fold symmetry.

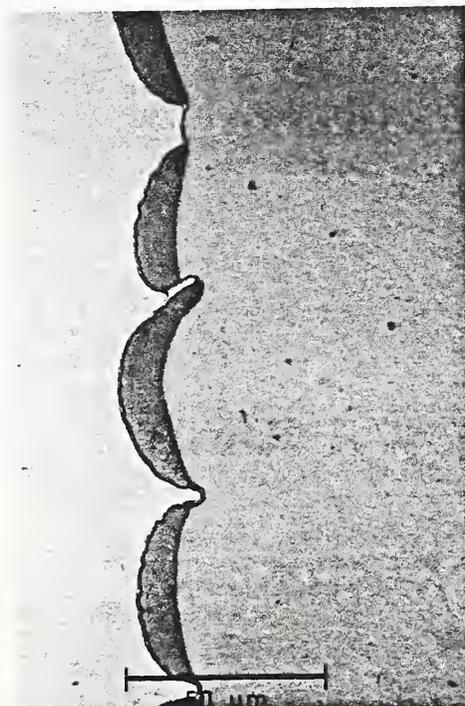

Figure 4. Interfacial instability in Mo-Ni. Pure Mo single crystals and Ni were heated to 1450 °C for 10 min. The shades of grey indicate a change in Ni concentration. Precipitation of the Ni saturated solid solution occurs at the peaks of the instability and dissolution occurs in the valleys.

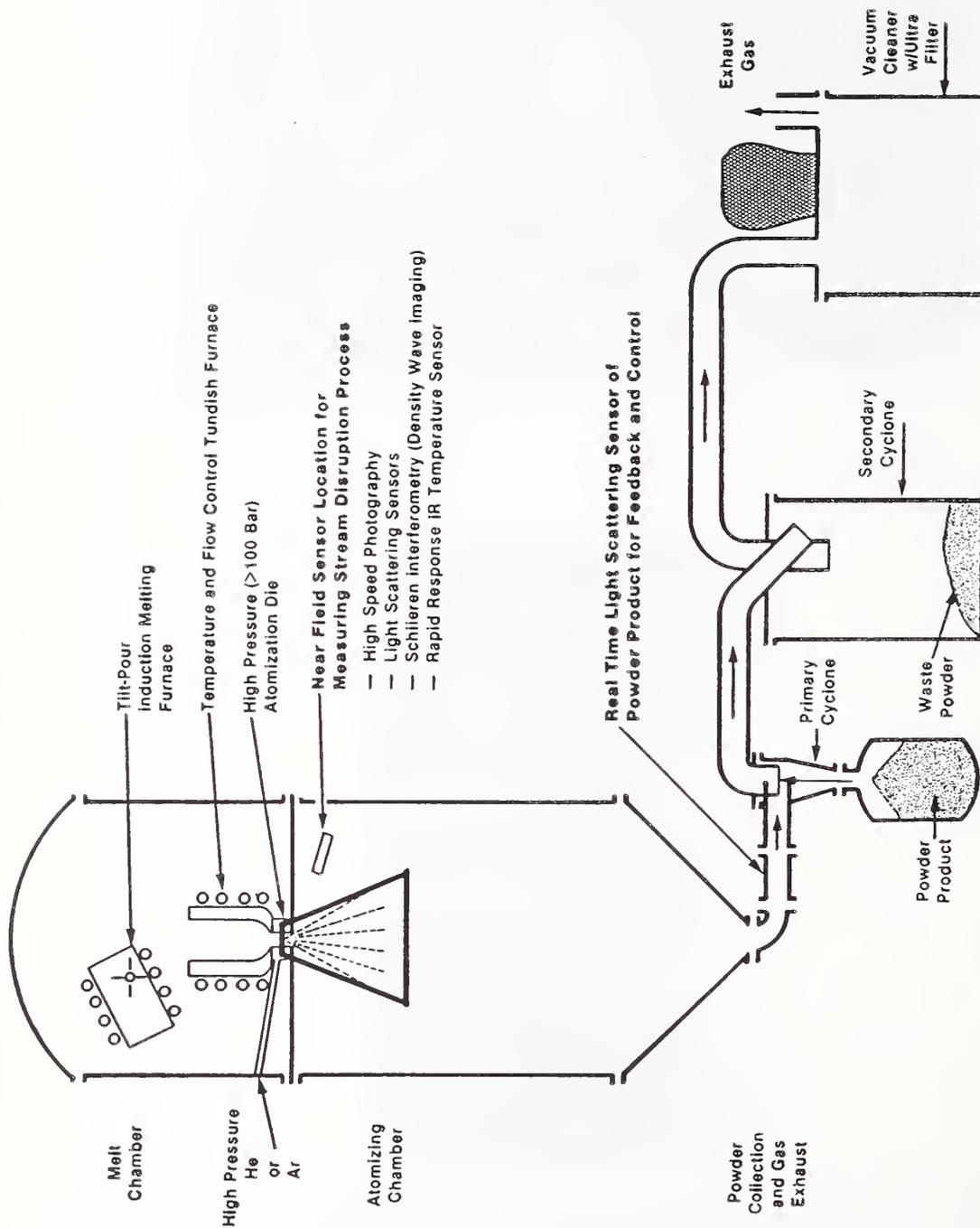

Figure 5. Schematic of high pressure inert gas atomization system showing the location of sensors.

CORROSION

Corrosion is one of the major causes of the shortening of service life of metallic structures. Corrosion is also a contributing factor in many catastrophic failures with the consequent loss of life and property. The cost of corrosion to the U.S. economy is estimated in excess of \$100 B/year. A significant fraction of this cost could be avoided by better utilization of present knowledge and by new research findings. The impact of corrosion is felt over a very wide range, from consumer items such as automobiles to chemical plants and naval ships and planes.

In FY87 work was carried out in four main areas: 1) basic research on the mechanisms of corrosion, 2) development of corrosion measurement techniques 3) dissemination of evaluated literature data on corrosion and 4) studies of corrosion problems arising from the proposed disposal of high level nuclear waste.

Stress corrosion cracking (SCC) has been the focus of the mechanisms research during FY87. The cause of SCC is still poorly understood. Critical experiments have been done this year to examine the several different proposed mechanisms. Theoretical work has been conducted to advance our understanding of electrochemical effects in SCC.

Extensive experience in the Group with corrosion measurement techniques has been applied in the area of localized corrosion. Electrochemical noise measurement techniques have been used to study corrosion pit initiation, and statistical analysis methods have been developed. Studies are underway to determine the corrosion characteristics of a metallic glass in both pitting and nonpitting environments.

The joint NACE-NBS Corrosion Data Center has seen considerable development in this past year. The Center is serving as a central source of reliable, evaluated corrosion data. Increasing cooperation with industry, other organizations, and other countries has been seen this year. Two Industrial Research Associates are now working with us at NBS in this effort.

Our assistance to the Nuclear Regulatory Commission on corrosion problems associated with the disposal of high level nuclear waste has grown considerably. This activity concerns a critical national problem with specific timetables set by law. Metallic containers of highly radioactive materials are proposed for burial at a geologic site to be selected and are expected to withstand corrosion for at least 1000 years, well in excess of present industrial experience. Our work involves both information and data analysis, as well as critical laboratory measurements.

FY 87 Significant Accomplishments

- o In the effort to model the electrochemical processes occurring inside cracks which influence stress corrosion cracking (SCC), calculations have been carried out to determine the range of values of the minimum in electrode potential at the crack tip in the case of Cu-Au alloys in

in chloride solutions. The results have proved unequivocally that hydrogen embrittlement cannot be the mechanism responsible for SCC in these alloys.

- o The NBS-NRC Data and Information Center has established a library for corrosion, leaching, and high level waste package information as well as a data base for storage and retrieval of NBS critical reviews and pertinent information. The information contained there largely involves review and evaluation of the DOE reports related to waste packages being proposed for permanent storage of high-level radioactive waste.
- o The NACE-NBS Corrosion Data Center completed programming for software products based on NACE corrosion data surveys for metals and nonmetals in a wide variety of industrial environments. Joint efforts with NACE and ASTM task groups have established guidelines for standardization of corrosion data formats to facilitate development of a complex evaluated database to serve as the basis for additional distributed software addressing specific industry needs.
- o Combined acoustic emission and stress corrosion cracking experiments were performed on stainless steels (alloys 304, 310, 316 and 316 ELC). Cracks were shown to advance with periodic bursts of acoustic energy indicative of discontinuous propagation; the crack velocity during advance was estimated as greater than 1 m/s.
- o Electrochemical measurements combined with scanning electron microscopy and energy dispersive x-ray analysis were used to determine effects of saline solutions on the durability of heart pacemaker leads consisting of a Co-Ni-Cr-Mo alloy in a polyurethane sheath.
- o The role of grain boundary precipitate size distribution in the intergranular stress corrosion cracking of Al-Li and Al-Li-Cu alloys was evaluated by conducting slow strain rate tests on samples with reverted or resolutionized matrix precipitates. These experiments show that it is the grain boundary precipitate size distribution, not the matrix slip character, that is responsible for the beneficial effect of heat treatment on the stress corrosion resistance of these alloys.

Mechanisms of Stress Corrosion Cracking

E.N. Pugh, U. Bertocci, R. Ricker, R. Rothea*, M. Stoudt, and J. Fink

* Guest Scientist, Rhone Poulenc, Inc./University of Lyon, France

Mathematical modeling of the electrochemical and transport processes inside a crack has been extended to the case of Au-Cu alloys, which undergo transgranular stress corrosion cracking (TSCC) which is morphologically identical to cracking in brass. The calculations have shown that during cracking in Fe Cl₃ solutions the anodic reactions at the crack tip (fig. 1) are likely to be the reduction of Fe⁺⁺⁺ and of Cu⁺⁺, both mainly present as chloride complexes. In order to estimate the range of potentials to be expected at the crack tip at the instant of crack

advance, reliable kinetic data for the redox reactions $\text{Fe}^{+++}/\text{Fe}^{++}$ and $\text{Cu}^{++}/\text{Cu}^+$ on gold surfaces were necessary.

Potentiodynamic scans and a.c. impedance spectra carried out in solutions similar to those present in the crack have provided the necessary values for completing the mathematical modeling. The results show that hydrogen cannot possibly be discharged inside the crack, and therefore hydrogen embrittlement cannot be the cause of brittle fracture in these alloys.

Stress corrosion cracking (SCC) experiments were performed on single crystals of pure copper in sodium acetate and sodium nitrate solutions. The objective of these experiments was to evaluate the hypothesis that surface oxide films can induce cleavage crack propagation and are responsible for transgranular SCC. Slow-strain-rate tests were conducted in solutions of varying pH at constant electrode potentials. These experiments were coupled with cyclic voltammetry and ellipsometry experiments in the same solutions to evaluate the surface oxides present and their stability at each potential. For both types of solutions, susceptibility to transgranular cracking was found in potential ranges where an oxide is stable and no cracking was found if an oxide film was not present (fig. 2). While an oxide film may be required for transgranular SCC (TSCC), the presence of a film alone may not be sufficient to induce TSCC. However, it is evident from both cyclic voltammetry and the ellipsometry that the oxides behave differently in the two solutions and that the characteristics of the film other than just its rate of growth are important in determining the susceptibility to TSCC. Clearly, further work is needed to establish the nature of the oxides and to evaluate the role of the oxide properties in inducing stress corrosion cracking.

Combined acoustic emission and stress corrosion cracking experiments were performed on stainless steels (alloys 304, 310, 316 and 316 ELC) to examine the discontinuous nature of TSCC, to evaluate the potential of acoustic emission as a technique for detecting and monitoring stress corrosion cracking propagation and to estimate the maximum velocity of crack propagation during the discontinuous advance. Stress corrosion cracks were shown to advance with periodic bursts of acoustic energy indicative of discontinuous propagation. The observed signals were unique to SCC propagation making it possible to monitor or detect SCC propagation. The crack velocity during advance was estimated as greater than 1 m/s. These results confirm the hypothesis that stress corrosion cracks propagate in a discontinuous fashion consistent with the film induced cleavage mechanism of stress corrosion cracking.

The role of grain boundary precipitate size distribution in the intergranular stress corrosion cracking of Al-Li and Al-Li-Cu alloys was evaluated by conducting slow-strain-rate tests on samples with reverted or resolutionized matrix precipitates. This heat treatment allowed the precipitate size distribution at the grain boundary to be varied while maintaining the matrix precipitate size distribution and mechanical properties essentially constant. These experiments show that it is the grain boundary precipitate size distribution and not the matrix slip character that is responsible for the beneficial effect of heat treatment on the stress corrosion resistance of these alloys.

Corrosion Measurement Methods

U. Bertocci, D. E. Hall, G. S. Stafford

The work on the statistics of corrosion pitting has continued with the development of the statistical analysis of the current fluctuations preceding pit initiation. In the part of the program pursued in cooperation with the University of Manchester in the United Kingdom, data concerning pit distribution on carbon steel plates are being collected. Methods to analyze the results, based on extreme-value statistics, are being developed.

Corrosion of Al-Mn metallic glass coatings has been studied in both pitting (chloride) and nonpitting (sulfate) environments. The alloys, with manganese contents ranging from about 10 to 30 percent by weight, were electrodeposited from a molten salt bath by the NBS Electrodeposition Group. Limited corrosion data in the literature suggested that the alloys might be superior to pure Al in some environments. Our research to date has determined the corrosion characteristics in both pitting and non-pitting environments. The most noteworthy result is the difference in pitting behavior between the alloys and either pure aluminum or electrodeposited aluminum. The onset of pitting for the alloys is roughly 400 mV more positive than that for aluminum. Furthermore, the pits which form in the alloy coating are shallower than those in aluminum. These results suggest that Al-Mn coatings may offer a high degree of corrosion protection to underlying base metals.

Corrosion Data Center

D. B. Anderson, C. D. Flanigan, T. Flax, P. Karras*, G. M. Ugiansky, and E. D. Verink**

* Research Associate, NACE

** IPA, University of Florida

The NACE-NBS Corrosion Data Center continues as a focal point for computerization of corrosion data to characterize corrosion performance of engineering materials over a wide variety of environments and exposure conditions. Activities during 1987 centered on (1) programming software based on NACE surveys for both metals and nonmetals and the NACE Recommended Practice for assessing economic aspects of materials selection for corrosion environments, (2) acquisition of existing industrial corrosion data, (3) developing a database structure to facilitate capture of multi-source corrosion data in formats compatible with defined user needs and (4) with assistance from the Center for Applied Mathematics, developing PC software utilizing the stability diagram programs originally created at the University of Florida to study corrosion thermodynamics.

Programming of the NACE survey data has been completed and resulting PC software is being marketed by NACE as CORSUR Corrosion Data Software. The programs permit material compatibility searching for user defined environmental conditions (fig. 3) which greatly enhances the usefulness of the base data. Programming has also been completed for the companion economics software for NACE distribution during FY88. The complex

stability diagram programming is continuing. Working in conjunction with task groups within NACE and ASTM, basic guidelines have been established for standards development in the important area of corrosion data formatting. This will facilitate data recording and capture in standard formats compatible with database management needs and other material property database developments. These formats are serving as the basis for a database structure used to compile numeric data from existing industrial sources and facilitate distributed outputs targeted towards specific environments and applications.

Recognizing the complexities of corrosion data interpretation for materials selection in key chemical environments, the Materials Technology Institute of the Chemical and Process Industries (MTI) has initiated a contract with NACE which has resulted in the establishment of a new three year Research Associate program in the Data Center to exploit growing interest in expert system technology.

Nuclear Waste Packaging Materials

C. G. Interrante, D. Anderson, U. Bertocci, P. Boyer, I. Coyle, E. Escalante, A. Fraker, D. Hall, J. Harris, S. Harrison, W. Liggett, M. Linzer, H. Ondik, E. Plante, E. N. Pugh, R. Ricker, A. W. Ruff, J. Ruspi, A. Sembira*, R. D. Shull, M. Stoudt

* Guest Scientist, Atomic Energy Commission, Israel

In a program titled "Evaluation and Compilation of DOE Waste Package Test Data," initiated in FY85, the NBS supports the High Level Waste (HLW) Management Program of Nuclear Regulatory Commission (NRC). The NBS assists the NRC by evaluating the Department of Energy's activities on high level waste disposal. These waste packages are being designed for use in a permanent repository for the disposal of radioactive waste from nuclear power plants and other sources. Potential problems threatening the integrity of a waste package include pitting, stress corrosion cracking, and hydrogen embrittlement. These problem areas are the main thrust of the Metallurgy Division's effort in addition to program management. Another area of concern is leaching of borosilicate glass, and this effort is carried out in part by members of the Ceramics Division. The program is also supported by statistical and modeling specialists from the Center for Applied Mathematics, as well as by six consultants from outside NBS. During this year, an HLW Data Center was established at NBS. The collection includes over 500 papers and technical reports. A computerized data base was created and implemented to provide access to these materials. The data base includes the full text of all technical reviews completed and in-progress.

Various forms of technical assistance are rendered to the NRC. The work involves conducting formal reviews -- over 40 were completed in FY87 for publication -- of the research and development efforts of the DOE Waste Package Program, technical review of other related documents (NRC, DOE and their contractors) interaction with the international technical community and general review of all relevant present and planned activities of the DOE. These include expected modes of degradation, evaluation of various other failure modes, test methods, design of

experiments, theoretical and modeling efforts, and laboratory testing. An important objective is to identify additional data and types of tests needed to demonstrate that the DOE waste package designs will meet NRC's performance objectives. At the NBS, laboratory testing is conducted to confirm the accuracy of DOE data and the validity of the conclusions deduced from it. This year laboratory studies were initiated in the Division in four areas, as follows: (1) Evaluation of Methods for Detection of Stress Corrosion Crack Propagation in Fracture Mechanics Samples, (2) Effect of Resistivity and Transport on Corrosion of Waste Package Materials, (3) Pitting Corrosion of Steel Used for Nuclear Waste Storage, and (4) Corrosion Behavior of Zircaloy Nuclear Fuel Cladding.

Surgical Implant Metals

A. C. Fraker and J. S. Harris

Metals and alloys that were studied this year included those used as heart pacemaker leads and used for orthopedic devices. The laboratory investigations involved corrosion, microstructures, alloy composition and mechanical properties. Other efforts in this task included numerous interactions with surgical implant manufacturers and participation in the American Society for Testing and Materials F-4 Committee on Medical and Surgical Materials and Devices.

Heart Pacemaker Leads - This was a cooperative study with the Food and Drug Administration (FDA). A Co-Ni-Cr-Mo wire lead in a polyurethane sheath or tube was exposed to simulated body fluids for 14 months. Failures have been observed due to the degradation and leakage of the polyurethane insulating material. Mechanisms of the polyurethane degradation and reactions of the Co-Ni-Cr-Mo wire use have not been established. Our tests were conducted to determine if the polyurethane did actually leak and what the effects were on the wire and the polyurethane. After exposure of the shielded lead in simulated body fluid at voltages varying from 5 volts to 20 volts, it was evident that leakage had occurred in a number of sites in the polyurethane. Scanning electron microscopy and energy dispersive x-ray analysis (fig. 4) showed that the metal had corroded at these sites and metal corrosion products were on the inner surface of the polyurethane. Small angle x-ray scattering measurements indicated that metal ions diffuse preferentially through the soft segment of the polyurethane.

Alloys for Orthopedic Devices - Materials studied include 316L stainless steel, Co-Cr-Mo, Ti-6Al-4V and Co-Ni-Cr-Mo. Other materials proposed for surgical implant use such as nitrogen-strengthened stainless steel, beta titanium alloys and the Ti-5Al-2.5Fe are studied for comparison. Corrosion, repassivation kinetics, pitting and corrosion-fatigue behavior of these materials in simulated body fluids are studied. Previous data from this project showed comparisons of fatigue strength of the various orthopedic materials and effects of processing and surface treatment on corrosion-fatigue. Current emphasis is on the Ti-5Al-2.5Fe alloy, beta titanium alloys, and nitrogen-strengthened stainless steel. Work involves relating microstructures and mechanical properties of Ti-6Al-4V to variations in composition (especially oxygen) and heat treatment. This is a cooperative study with the Zimmer implant manufacturing company.

WEAR

Measurements of wear and friction properties are carried out to (1) improve understanding of fundamental physical and chemical mechanisms, (2) to develop better quantitative measurement methods, and (3) to develop standards and reference materials. Experimental methods used include wear testing, optical and electron microscopy, microindentation measurements, metallography, surface microanalysis, and wear particle analysis. Analytical modeling is done of break-in effects in friction and wear.

Costs associated with wear failure and inadequate tribological performance have a significant economic effect in the U.S. and the world. Estimated costs of wear are about \$50 B/year in the U.S. Greater use of more wear-resistant materials (and data on existing materials) can improve industrial productivity and our competitive position world-wide. This task is developing test methods and evaluating new materials having improved wear properties. Data obtained on such materials may be used then by design engineers in new applications. One area of emphasis in this task is that of wear data for commercially important alloys and coatings, both existing and new.

The program is supported in part by other Federal agencies in recognition of the importance of adequate wear behavior of machinery and mechanical systems. The Department of Energy (DOE) supports our work in galling wear of materials where new measurement methods for quantitatively assessing galling performance have been developed. New industrial valve materials and coatings have been examined in this work. The Office of Naval Research supports a research project on the mechanisms of wear in engineered metallic coatings having unique microstructure.

Several activities in the Group have direct involvement with private industry. We are conducting joint measurements with Deere and Company, Moline, IL, on galling wear properties of materials. A Research Associate from the company is investigating problems connected with the measurement of galling damage and the development of tests to determine the galling behavior of metals. In another project, a Research Associate is conducting wear measurements at our laboratory involving a hybrid liquid-solid lubricant that can be used with sliding metal surfaces at elevated temperatures. In addition, our wear data evaluation and compilation efforts are done in conjunction with several private companies and universities.

FY 87 Significant Accomplishments

- o Abrasive wear coefficients have been evaluated for a group of frequently used metals under standard wear test conditions, and assembled into a data base for use in a new, PC-based, tribology data and information system (ACTIS) being developed under the sponsorship of several federal agencies and professional societies.
- o A new type of hybrid, liquid-solid, lubricating material has been produced and studied under elevated temperature sliding wear

conditions; it was found to offer significant protection to steel surfaces. The concept involved should be extendable to a broad range of other materials and wear conditions. This work was conducted jointly with a Research Associate.

- o Wear and friction behavior of electrodeposited, composition-modulated nickel-copper coatings on steel have been measured under both lubricated and unlubricated sliding conditions and found to offer significant improvement over the pure metals. The basis is believed to lie in the unique microstructure of the coatings which are produced at NBS in the Electrodeposition Group.
- o The galling behavior of nitrated steels was investigated and showed that surface nitrating significantly increased galling resistance. Galling severity measurements used an NBS developed method based on surface topographic parameters. This work was conducted jointly with a Research Associate.
- o Studies have verified that undesirable time-dependent sustained slow cracking occurs in seamless aluminum cylinders made of alloy 6351 and used for gas storage and air-breathing applications. Modifications to the processes for producing these cylinders have been made to reduce the significance of this cracking.

Mechanisms of Galling Wear

L. K. Ives, M. B. Peterson, E. Whinton and P. Swanson*

* Research Associate, Deere and Co.

A project on the galling wear of metals is partially sponsored by the Department of Energy. Galling is a form of wear which occurs on sliding surfaces leaving them severely damaged due to plastic deformation, fracture, and metal transfer. It usually occurs in poorly lubricated or heavily loaded components such as valves, threaded connections, structural joints, or bushings. Our approach has been to study the influence of various metallurgical parameters on galling severity, where galling severity is a measured quantity based on surface topography such as displaced volume or average maximum peak to valley roughness.

Recent work has been concerned with the development of models for the galling process. An extensive literature search was undertaken to supplement experimental data on galling obtained in the program. It was concluded that galling is basically a shear fracture process with fracture beginning at the rear of a local contact area. The severity of the galling damage is determined by the deformation process which precedes fracture. Some important factors influencing galling severity are crystal structure, stacking fault energy, and the available slip systems. Surface roughness can also have a significant effect on galling severity. Adhesion is important in that it influences the contact stresses. With high adhesion large protrusions may form increasing the extent of the damage which occurs.

Galling damage in a variety of commercial alloys has been studied. As shown in figure 5, hardness does not correlate with damage severity among the

metals tested. Also, stainless steels, as a group, do not behave more poorly than other metals as has sometimes been stated. It may be noted that Nitronic 60, which is an austenitic stainless steel, shows little damage. Our studies have indicated that this behavior is a result of the low stacking fault energy of this alloy. The damage to leaded brass is also low. This is attributed to the presence of a thin film of lead that is smeared over the surface during sliding which acts as a lubricant.

Wear Properties of Metal Coatings

A. W. Ruff, E. Whitenton, J. Robbins, and N. K. Myshkin*

* Guest Scientist, U.S.S.R

A study has been completed of the lubricated wear behavior of electro-deposited composition-modulated nickel-copper alloys having two different layer spacings, 10 nm and 100 nm, under lubricated sliding conditions against type 52100 bearing steel. The alloys were prepared as coatings about 20 μ m thick on steel cylinders. A standard crossed-cylinder wear test geometry was used. Three liquids were used: pure paraffin oil both with and without the addition of oleic acid, and a solution of 0.6 glycerine and 0.4 ethanol. Electrical measurements of the contact resistance were made to assist in interpretation of the nature of the boundary lubrication film present during sliding. Wear data and friction coefficient values were obtained. The lubricated wear behavior of the two composition-modulated Ni-Cu coatings differed considerably from that of the two pure deposit coatings of Ni and Cu. The two Ni-Cu coatings generally showed less wear, and the coating with the smaller laminar spacing, 10 nm, showed the least wear. Among the three lubricants examined, the Ni-Cu coatings showed the least wear with the 0.6 glycerine-0.4 ethanol mixture. Somewhat greater wear occurred in paraffin oil, and greater still when oleic acid was added. The pure deposits of Ni and Cu showed greater wear than the alloys and responded differently in the three fluid media. Friction coefficients were nearly the same in all the media. Contact film voltage measurements showed that the Ni-Cu coatings had very low values relative to steel, and to the copper and the nickel coatings. This was interpreted to show a thinner film in the contact for the Ni-Cu coatings, but a more durable one. The Ni-Cu coatings may be suitable for use in current collection in view of their low wear and low contact resistance.

Mechanisms of Solid Lubrication

M. Peterson, L. K. Ives, A. W. Ruff, L. Fehrenbacher**, and J. Macia**

** Research Associates, TA&T, Inc.

Recent experiments in our laboratory have shown that it is possible to develop a hybrid solid-liquid lubricant with improved performance for possible use in high-temperature friction and wear environments. Using our high-temperature sliding wear test system, studies were conducted on various combinations of synthetic lubricants with liquid and dry powder additives. The formulations consisted of nickel and chromium intercalated graphites at concentrations of about one-weight percent in the liquid

carriers. Tests were performed up to 250°C under highly loaded boundary lubrication conditions. Further studies also indicated that solid composites of metal or ceramics with these intercalated graphites may have desirable wear and friction characteristics for such applications as ring-liner combinations in high-temperature engines.

Friction and Wear Break-in

P. J. Blau and E. Whitenton

Studies of the mechanisms of break-in and other tribological transitions in metals and alloys have resulted in the development of a framework for a semi-empirical friction model of these processes. Provision for incorporating parameters of the test geometry (including surface roughness), materials and microstructural properties, state of lubrication, chemical and thermal environment, and mechanical test conditions has been made, although terms for all these effects have not been completely developed. Preliminary application of the model to unlubricated sliding break-in tests (on Cu-15 wt%Ag) and polishing abrasive sliding tests (52100 steel, 2014-T4 aluminum, was successful in portraying the cycle number-dependence of the friction coefficient. The model was favorably received at the 1986 ASME/ASLE fall meeting (Pittsburgh, PA), and has been published. Work on the analytical model to incorporate existing wear damage theories for known mechanisms of wear, and to develop terms for transition incubation times under various thermal and applied load conditions will be continued.

Wear Data and Standards

A. W. Ruff, M. B. Peterson, J. Harris, and J. Robbins

As part of the first coordinated attempt in the United States to gather and evaluate important data about friction, lubrication, and wear between materials, the initial phase of a project on abrasive wear has been completed. With support from the Department of Energy, the principal sponsor on the project, the American Society of Mechanical Engineers and the American Society of Lubrication Engineers, data have been gathered and evaluated about how materials hold up under different conditions of abrasive wear (fig. 6). The data are entered into a personal computer system for easy access and updating. Discussions have been held with interested industrial organizations on the best way to share the database, which is limited at this stage to selected materials. One possibility is an expansion of NBS-industry collaborations through the Research Associate Program. In many industrial operations, the wear of machine components and materials is one of the key factors in determining the service life and down-time of equipment. Data on how materials wear while in operation helps equipment and process designers as well as plant operators make the most of their capital equipment investments and increase productivity.

Staff members continue to participate in the wear standardization work of the ASTM G-2 Committee on Wear and Erosion. Chairmanship is held of the Operations subcommittee, the Task Group on solid particle jet erosion testing, and the Task Group on pin-on-disk testing. In the latter Group, a draft standard has been written that will be the first such U.S.

standard. It is partly based on an international measurement effort that was formed under VAMAS. Major contributions are also made in the task groups on galling wear, on crossed cylinder wear testing, and on friction measurements. Several future symposia and workshops are being planned. There are about 80 members of the Committee from private industry, so there is ample opportunity for the NBS staff to interact in an effective manner.

Mechanical Properties of Pressure Vessels

J. H. Smith and P. A. Boyer

Research is carried out under sponsorship of the Department of Transportation Office of Hazardous Materials to establish a sound, technical basis for safety standards governing the safe design, manufacture, and use of seamless pressure vessels (cylinders) for the storage and transportation of compressed gases. This research includes the technical evaluation of proposed changes to the existing safety regulations, development of new or improved test methods for selecting materials, development of improved methods for the testing and inspection and failure analysis to determine the cause of failures in cylinders.

Research has continued to develop design criteria for the construction of high strength seamless steel cylinders. The objective of this work is to develop suitable criteria to prevent failure of high strength cylinders by fracture or by stress corrosion. Cooperative tests programs with Union Carbide Corp., T.I. Chesterfield Ltd., and N.I. Industries are being conducted to establish a fracture criteria for steel cylinders. Extensive full scale testing of preflawed cylinders and fracture toughness testing has been conducted. A minimum fracture toughness, in terms of J_{Ic} , has been established for the production of a limited size range of cylinders. Research is continuing to extend the size range of cylinders to which this fracture criteria can be applied. In addition tests are being conducted to establish a fracture criteria that more accurately predicts the fracture behavior of thin walled, ductile steel cylinders. An improved test procedure based on the use of pneumatic burst testing of preflawed cylinders for use as a quality control test during production is currently being developed. Analysis of existing data on the stress corrosion susceptibility of high strength steels is being performed to establish a maximum limit of the strength of high strength steel cylinders to preclude failure by stress corrosion cracking.

A unique form of intergranular cracking has been found in the neck and thread area of type 3Al aluminum and fiberglass wrapped aluminum cylinders. An ongoing investigation to determine the extent and cause of this cracking is being conducted in cooperation with Luxfer USA Inc. and Alcan Ltd. An example of the cracking that has been found is shown in figure 7. In a few cases, cracking has propagated through the neck and caused leaking. Investigations at NBS in the past year have confirmed that this cracking occurs in all sizes and classes of aluminum cylinders made from type 6351 alloy. This has resulted in a recall from service of certain groups of these cylinders. Modifications of the alloy composition and manufacturing process have been made to reduce the tendency for this

form of cracking. Results of tests on cylinders made from the modified alloys and manufacturing processes are currently being investigated. Research is being conducted on developing a method of using a combination of acoustic emission and ultrasonic testing for the periodic reinspection of large seamless steel cylinders used for transporting compressed gases. Extensive testing of full sized cylinders using this method has been conducted by the Linde Division of Union Carbide Corp. and by Fiba Inc. Recent testing has demonstrated that this test method can reliably detect most of the types of defects that occur in compressed gas cylinders during normal service. A preliminary standard test procedure has been developed for the use of this test method.

Micromechanical Properties Measurements

R. S. Polvani, A. W. Ruff, and J. C. Robbins

The NBS Dynamic Microindentation system has been used to make measurements on an energetic material, crystals of RDX, to determine the effect of load and loading time on their mechanical response. A spherical indenter tip was used. The results have been compared to those obtained earlier using pyramidal Vickers indenters. At the shortest loading periods with a spherical indenter, a higher than expected plastic response was found; this may indicate that local heating resulted from the indentation process. The pyramidal indenter generally produced a different response, probably due to its stress concentration effects (fig. 8). As a result of this work two important mechanical characteristics of RDX have been recognized. The first involves the importance of indenter geometry. At high loading rates, the plastic behavior of RDX depends on the stress concentration effect of the indenter geometry. It appears that RDX is not inherently brittle as has been reported. Irrespective of the loading rate, RDX was found to deform plastically for loadings up to 2 N using a ball indenter. The second characteristic was that RDX became more ductile under conditions of rapid indentation, in time intervals of 1 ms. This may have resulted from local heating of critical regions in the RDX crystals, thus affecting dislocation motion and interaction. A model of dynamic mechanical behavior of energetic materials has been developed in this work in collaboration with the University of Maryland.

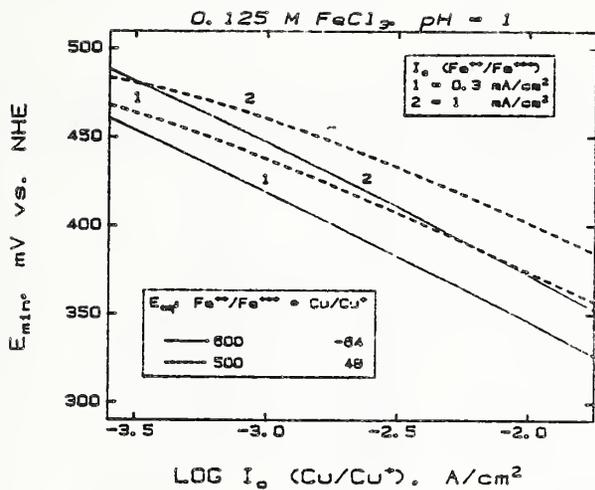

Figure 1. Calculated minimum electrode potential reached at the crack tip during TSCC of Cu-Au alloy for various exchange current densities.

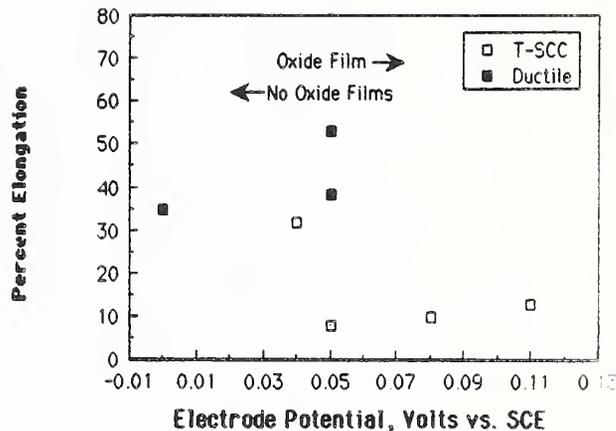

Figure 2. Results from slow strain rate tests of pure copper monocrystals in 0.1 sodium acetate (pH = 5.5).

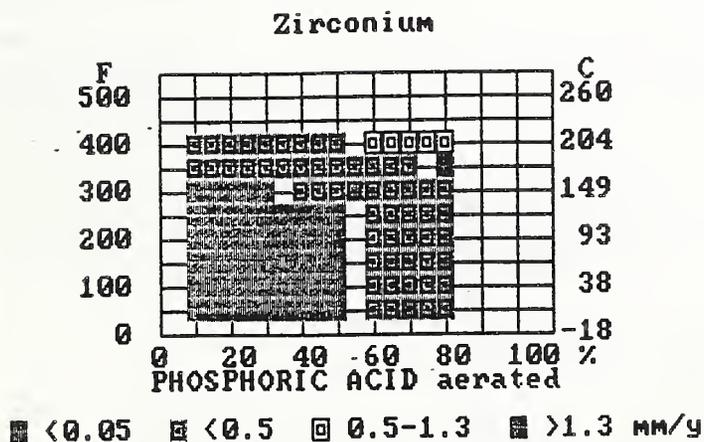

Figure 3. Computer-generated display corrosion rates of zirconium as a function of concentration and temperature in aerated phosphoric acid.

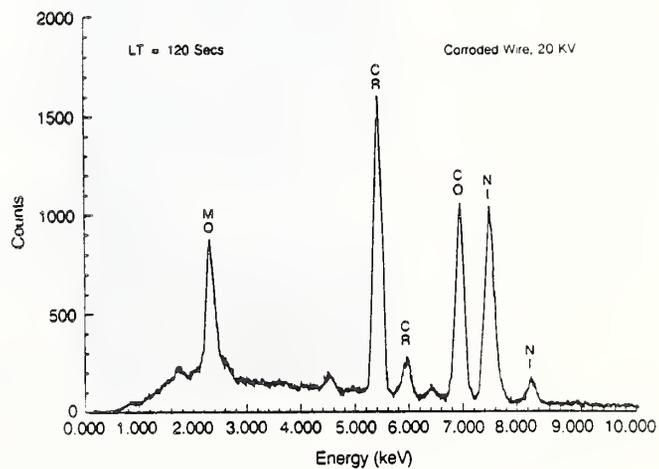

Figure 4. EDX analysis of corroded heart pacemaker wire, alloy Co-Ni-Cr-Mo, showing increased amounts of Cr and Mo.

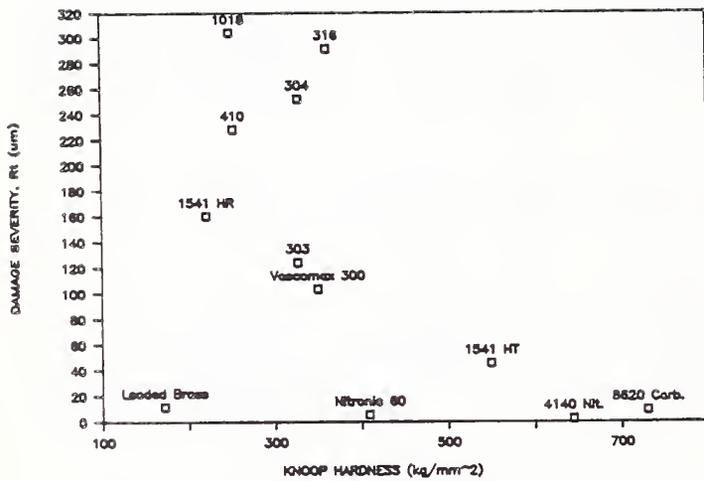

Figure 5. Effect of material hardness on galling severity.

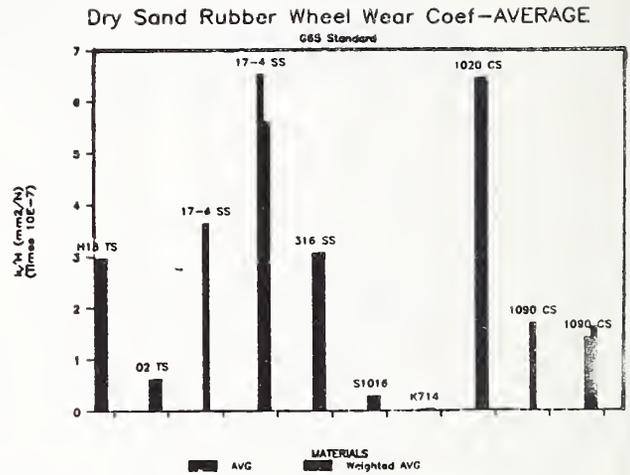

Figure 6. Average values for abrasive wear coefficient using ASTM standard method, as contained in Tribology Data Base.



Figure 7. Extent of cracking in aluminum cylinder neck.

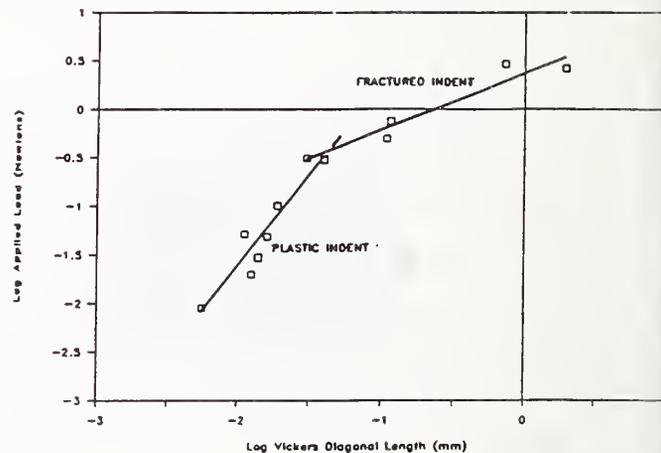

Figure 8. Pyramidal indentation of RDX crystal shows transition from plasticity to fracture at 0.3 N load.

The principal activity of this group is the collaborative effort with the American Society for Metals (ASM) in the joint ASM-NBS Alloy Phase Diagram Data Center. This program continues to provide critically evaluated phase diagrams and other constitutional data as well as related bibliographic material. ASM provides overall program guidance, bibliographic support, and dissemination of program outputs. NBS provides overall technical guidance to insure the data reliability and accuracy of the evaluated phase diagrams, development of a model evaluation procedure and style guide by the two binary category editors (magnesium, aluminum) located within the group for use by the other binary category editors, and the development of a prototype database for on-line retrieval of the phase diagram related data. The program has a strong international content through the alloy category editors who are responsible for the selection and evaluation of the data. Currently, there are thirty binary and twenty ternary category editors participating in this program. During the past year, the three NBS category editors completed evaluations of fifteen magnesium, four aluminum, and one iron system. The magnesium binary alloy systems have now been completed and are being compiled for publication as an ASM Monograph.

A new two volume compendium "Binary Alloy Phase Diagrams" has been published by ASM. The compendium updating the compilations of Hansen, Elliot and Shunk contains 1578 phase diagrams that were selected and digitized by the program at NBS. The interactive relational phase diagram database has been loaded with binary graphics, the numerical and crystal data of nearly 1600 binary phase diagrams.

The evaluation program has been extended to ternary diagrams with the initial evaluation of Al-Cu-X ternary diagrams. New optimization programs have been implemented for the calculation of ternary diagrams from thermodynamics and the boundary binary phase diagrams.

In phase stability studies of amorphous Al-Mn alloys (16 to 40 wt% Mn) produced by electrochemical deposition, return to the equilibrium structure occurs without the complex series of intermediate transformations seen in splat quenched Al-Mn alloys.

The analytical capabilities of the JSM-840 Scanning Electron Microscope has been greatly increased with the addition of a wavelength dispersive spectrometer and ancillary X-ray and image analysis.

FY87 SIGNIFICANT ACCOMPLISHMENTS

- o A relational database of the critical phase diagram data of nearly 1600 binary phase diagrams is ready for on-line search. The graphical and numerical data of these phase diagrams and the crystal data of the approximately 9000 phases in these phase diagrams are accessed readily by an easy data search program.
- o Evaluations of ternary Al-Cu-X systems were initiated. The Al-Cu-Pb, and Al-Cu-Bi systems are completed.

- o A compilation of 1578 updated binary phase diagrams with corresponding crystal structure data of the phases of each diagram was completed. A two volume compendium of these binary phase diagrams and the ancillary crystal structure data was published by ASM INTERNATIONAL.

Alloy Phase Diagram Data Center Activities

B. P. Burton, J. B. Clark, R. V. Drew, R. M. Hayes, L. F. Lilly*, A. J. McAlister, C. E. Sirofchuck*, and U. R. Kattner**

* American Society for Metals Research Associate

**Guest Scientist

All activities revolve about a collaborative data evaluation program for alloy phase diagrams with the American Society for Metals (ASM INTERNATIONAL). During the last year, the Alloy Phase Diagram Data Center has continued to be the focal point for the entire ASM/NBS Phase Diagram Program.

Phase diagram evaluation projects are being carried out by three category editors at NBS, J. B. Clark for magnesium alloys, A. J. McAlister for binary aluminum alloys, and L. J. Swartzendruber for iron alloys. Coverage of the systems includes crystal structure, metastable and constrained equilibria, and high temperature thermodynamic properties as well as the stable equilibrium diagrams. Calculations of the phase diagram from thermodynamic data are carried out using a number of computer programs available at NBS. The data center staff are responsible for selection of reviewers for evaluations submitted to the Bulletin of Alloy Phase Diagrams, technical editing of evaluations and graphics digitization of submitted evaluated phase diagrams. The Bulletin of Alloy Phase Diagrams continues to be published at the rate of six issues per year. Technical editing is done by the editor, J. B. Clark. Over 250 evaluations were technically edited for the Bulletin, and the Gold and Beryllium Monographs. C. E. Sirofchuck supervises the computer entry of the graphical and crystal data. Approximately, 700 binary phase diagrams were prepared for the above publications.

The relational binary phase diagram database contains all the graphical data of a given binary system either as published in the Bulletin of Alloy Phase Diagrams or in the ASM compendium "Binary Alloy Phase Diagrams". The critical points of the diagram, the invariant reactions, the crystal data of all solid phases of a system are filed in the database. All the graphical and numerical data can be assessed by an easy search program.

Throughout the year, the database was loaded continually. It now contains the data of approximately 1600 binary phase diagrams (9000 phases, 7300 invariant reactions). The database is essentially complete and is ready to be transferred to ASM INTERNATIONAL. It is planned initially to offer the database off-line. Later the numerical data part of the database may be made available in a form suitable for search by IBM personal computers. An additional sub-database for the entry of ternary phase diagram data was added to the Phase Diagram Database. The ternary database contains three relations: Ternary - analogous to the binary relations of the binary database, Phases - data on phases in the ternary phase diagram, Invars - data on ternary invariant (four phase) reactions. An additional relation, Quasi-Binary, may need to be

added to handle these unique ternary phase relations. To date, the data for two ternary systems have been entered in this database.

Efforts have been made to improve and update computer programs for thermodynamic calculation of phase diagrams. In line with this, the THERMOCALC Database program was brought on board and utilized in evaluation of ternary systems. A minimal theoretical model for phase relations between B₂, L₂, and liquid phases for application in the NiAl-NiTi pseudo binary systems was formulated. This model permits evaluation of the roles of higher-order phase transitions and T₀ curves in rapid solidification processing of these alloys. For the program BINARY (calculation and optimization program for binary phase diagrams), an IBM-PC version was developed. A quick graphic display module also was developed and added to BINARY.

The evaluation of Al-Cu-X ternary phase diagrams was initiated. The Al-Cu-Pb and Al-Cu-Bi systems are completed. In these two Al-Cu-X ternaries, the phases of the Al-Cu binary penetrate only slightly into the ternary diagram and the published model for the Al-Cu system is adequate. However, for ternary diagrams in which the phases of the Al-Cu binary penetrate deeply into the ternary, the published Al-Cu model is oversimplified and is not suitable for extrapolation of the binary Al-Cu phases into the ternary. For such systems, new modelling of the Al-Cu binary is being developed.

Experimental Studies of Alloy Stability

A. J. McAlister

The major theme of the past years effort on phase stability was the study of the crystallization of metastable amorphous and icosahedral phase fractions in Al-based alloys. Amorphous alloys of Mn in Al have been produced at NBS by electrochemical deposition, in the composition range 16 to 40 wt% Mn. Heats and extreme temperatures of transformation have been obtained and correlated with structural data. Recovery to equilibrium appears straightforward, without the complex series of intermediate transformations seen in our earlier studies of splat quenched Al-Mn alloys. No glass temperature was observed, but in all samples the initial crystallization peak is preceded by an extremely weak exothermal peak not associated with any detectable structural change. Work continues on the clarification of this question. Similar studies have been carried out on splat quenched AlFeSi alloys which contain an amorphous fraction in the as-quenched condition, and on splat quenched AlMnSi alloys containing a considerable icosahedral fraction. Some studies on sputtered amorphous MoW alloys were also performed.

Electron Microscopy

A. J. Shapiro

The electron microscopy analytical capabilities have been expanded with the addition of a wavelength dispersive spectrometer to the recently acquired JSM-840 Scanning Electron Microscope. The wavelength dispersive spectrometer coupled with the Tracor 5500 and 5600 x-ray and image analysis has extended the capabilities of the JSM-840 Scanning Electron Microscope to that of a full fledged electron probe analyzer with light element analytical capability down to boron.

The Electrodeposition Group is responsible for measurements and standards associated with electrodeposited metals and alloys. The objectives of the group are: (1) the determination of the critical mechanistic, materials, and process variables controlling the structure/property relationships of electrodeposited coatings and the development of approaches that will result in entirely new materials; (2) the provision of standards such as coatings thickness standards, dye penetrant crack standards, and corrosion step test standards; (3) the development of new standards requiring electrodeposition for their fabrication or utilizing the unique properties of electrodeposited alloys; and (4) the provision of government expertise to industry, through research associates and standards organizations, and to government agencies, through appropriate contracts and consulting arrangements. Following are some of the many areas in which coatings are important to the commerce of the United States: (1) Strategic Materials - It has been shown that coatings can provide a 30% savings of imported raw chromium. Research on new alloys in progress indicated that for many applications, coatings can replace bulk stainless steels. (2) Corrosion-electroplated coatings play an important role in corrosion protection. It has been estimated that the cost of corrosion to the U.S. economy is in excess of 100 billion dollars per year. (3) Wear - The cost of wear to the U.S. economy has been estimated to be about 50 billion dollars per year. Electrodeposited coatings play an important role in improving wear properties and surface coatings can be optimized for particular wear situations. (4) Electrodeposition Industry - specifically plays an essential role in the United States Economy. For example, almost 900K tons of electrogalvanized sheet and strip are produced annually with an estimated impact of about \$150M per year projected by 1990, approximately 550K tons of metal coated wire and wire produced per year, tin plate accounts for 8800 tons with a dollar impact of \$120M, and foil production accounts for about \$200M per year. (5) Magnetic Materials - All hard disk drives are produced utilizing electrodeposition technology which thus has an important impact on the United States computer industry. (6) Processes - including decorative coatings, electroforming (compact discs) and electronic applications (contacts, PC boards etc) are so important that without electrodeposited coatings much of our current industry would not be able to function in its present form.

FY 87 Significant Accomplishments

- o Process Modelling - A mathematical model of a high speed alloy deposition process on a moving substrate has been completed and is capable of predicting the average and radial composition distribution. Though the model was aimed at metal matrix composites, it has a broad impact on all continuous processes.
- o Adhesion testing - Procedures have been developed and a number of coating-fiber combinations have been measured for the first time for both ceramic and metal matrix composites.

- o Artificial Superlattices - Magnetic measurements of artificial Cu-Ni superlattices of all principle orientations have been made for the first time and magnetic after effects have been observed in continuous films.
- o Wear Resistant Coatings - It has been demonstrated that introducing a one dimensional structural modulation into chromium can yield an alloy with a significantly enhanced wear performance under abrasive condition.
- o Aluminum Alloy Deposition - Alloys of aluminum manganese have been produced. The electrochemistry of the chloroaluminate solutions has been characterized and preliminary data on both microstructure and mechanical properties have been obtained.

Metal Matrix Composites

C. R. Beauchamp, S. A. Claggett, C. E. Johnson, D. R. Kelley, D. S. Lashmore, J. L. Mullen, P. N. Sharpless, and G. R. Stafford

Metal matrix composites are known to have a number of properties not attainable in homogeneous alloys. Such composites offer greater stiffness, superior high temperature performance and reduced weight. Unfortunately, a number of problems associated with current technologies and microstructure increases their cost and limit performance. Problems in the processing technology include the high cost of fabrication and difficulty in controlling the nature of the fiber-matrix interfaces. These interfaces, or interphase zones, not only are critical to bonding with the matrix, but also control stress distribution within the composite itself. The stress in the composite influences the fatigue behavior and crack formation near the fiber-matrix interface. Work underway in the electrodeposition group is addressing these problems by investigating how multilayered coatings rapidly applied on continuous fiber can not only act as precursors for MMC's but serve to reduce cost and suppress unwanted interfacial reactions.

The coated fiber is designed so that there is sufficient coating on the fiber to constitute the matrix when the coated fibers are hot pressed into a structure. In addition, tailored or graded alloys adjacent to the fiber are selected to promote bonding and to avoid high temperature reactions which might be deleterious to the composite performance. An idealized microstructure is shown in figure 1. Finally, a eutectic coating is placed on the "precursor" to reduce hot pressing temperature.

Tailored or Graded Alloys - There are three main types of tailored structures which are being produced: (1) structure modulated alloys, discussed below in the section on wear resistant coatings for the printing industry, (2) composition modulated alloys or superlattices, readily created by modulating composition. The modulation periodicity can be nearly atomically controlled so that graded materials can be created simply by varying the period of modulation. An example of a graded structure produced in this way is shown in figure 2a, and the measured hardness in figure 2b, (3) continuous concentration gradients, produced at very high rates of speed on moving fibers. These materials are inherently in a non-equilibrium state, with diffusion processes tending either to

homogenize the alloy or to lead to segregation into discrete phases with sharp, step-wise concentration discontinuities at the phase boundaries. In many systems, however, the non-equilibrium state can be retained indefinitely when the diffusion processes are too slow to have a significant effect on the composition distribution within the material. The deposition techniques and the properties of graded alloys produced by several of the techniques described above are currently under investigation.

Deposition of the Aluminum Alloys - the Matrix - Aluminum alloys cannot be efficiently deposited from aqueous solutions. However, their importance as matrix materials has led to an investigation of the properties of aluminum alloys electrodeposited from eutectic or fused salt solutions. A number of different alloys of aluminum with lithium, titanium, manganese, vanadium and numerous other constituents can be produced at deposition efficiencies exceeding 90%. These eutectic salt electrolytes operate at low temperatures (about 150 centigrade) and thus provide a means for measuring properties of composites created at the temperatures needed to suppress carbide formation, a problem which limits the high temperature use of these materials. In addition, the electrolytes are for the most part non-toxic, so that there does not seem to be a significant obstacle to eventual industrial adoption of the technology. Considerable progress has been made in understanding the electrochemistry of the alloy deposition process of aluminum-manganese. Deposits of pure aluminum have a nodular texture and are quite often dendritic due to the very fast kinetics associated with the reduction of $Al_2Cl_7^-$. The addition of $MnCl_2$ to the melt dramatically increases the activation overpotential, thereby promoting nucleation which results in specular deposits. The results of some linear sweep voltammetry showing the conversion of primary to secondary current distribution with the addition of $MnCl_2$ is shown in figure 3. The manganese content of the electrodeposit varies from 5 to 30 wt% and is dependent upon deposition potential and the relative concentrations of $Al_2Cl_7^-$ and Mn^{++} in the melt. The potential dependence of alloy composition allows one to create homogeneous, graded and modulated structures from a single electrolyte; an example of a modulated alloy is shown in figure 4. The structure of the as-deposited alloy appears to be that of a metallic glass above 27 wt% manganese and a mixture of glass and supersaturated aluminum below 27 wt% (figure 5). Upon heating to 400° C, the glassy structure converts to the orthorhombic Al_6Mn intermetallic while the supersaturated phase converts to Al_6Mn and aluminum. Both of these transformations may occur through the formation of some interesting metastable phases.

The hardness of the electrodeposit increases significantly with heat-treatment (figure 6) suggesting that a dispersion/precipitation hardening mechanism is operative. The ability to precisely control the deposition process will allow the electrodeposition of alloys in the form of coatings and matrix material (when deposited onto conducting reinforcement for metal matrix composites) with improved mechanical properties.

Process Modelling - Much effort is being applied to model theoretically the high speed deposition of alloys onto continuously moving fibers or wires and to verify this modelling by actual high speed deposition on a small scale. The mathematical model is now reasonably complete. The purpose of modelling

is of course to enable the prediction of composition or composition gradients within the coating, and their dependence on the deposition parameters. A model high speed plating cell has been constructed to complement the mathematical model and will be tested initially with nickel alloy deposition onto tungsten wires and eventually with silicon carbide fibers with the more complex series of coatings described above. A schematic diagram of the cell design is shown in figure 7 and results of the model are shown in figure 8.

Adhesion Measurements - Fiber matrix adhesion is a very important parameter in metal matrix composites. Techniques have been developed to directly measure this parameter by utilizing a modification of a instrumented microhardness testing instrument incorporating a load cell and a displacement sensor. The technique is simply to cut a section of the coated fiber perpendicular to its axis about 250um thick and polish both sides with a diamond abrasive. The microhardness diamond, usually a Vickers indenter, is then aimed at the fiber and the load displacement curve recorded on a computer system. An example of the raw data is shown in figure 9 with adhesion values determined from a combination of the surface area and the load at which slipping between the fiber and the matrix is first observed. Some adhesion data for a number of different fiber coating combinations is shown in figure 10.

Standard Reference Materials

H. J. Brown, H. G. Brown, F. Ogburn, D. R. Kelley, D. S. Lashmore, and P. N. Sharpless

This year research on the production of tin/lead standards continued. The fluoroborate plating was selected as the best process and a number of steel panels were plated. These panels were measured on both energy and wavelength dispersive X-ray units. The coating thickness distribution was determined on the energy dispersive unit. The computer programs for converting XRF measurements to composition and mass per unit area were tested with data obtained with the wavelength dispersive unit. The resulting data enables the estimate of precision of the measurements. It was found that the minimum thickness of copper over the steel substrate should be about 40 micrometers in order for the copper to appear infinitely thick. Surface roughness and its effect on the thickness measurements was investigated. Below a grit size of 600 the apparent thickness was not affected.

It was found that the X-ray measurement changes as a function of time, indicating that one of the species preferentially diffuses to the surface. Little information relating to electrodeposited coatings was found in a review of the literature. Samples were prepared and measured periodically for periods up to 80 days, and such measurements are being continued. These changes are shown in figure 11. The total changes observed are of the order of 2 to 3 %.

Approximately 6000 coating thickness standards were produced this last year. This accomplishment represents about a 16% increase from last year with no additional commitment of personnel. The increase in productivity can be attributed to incorporation of a pneumatic shear, a new electronic balance and improvements in the software used in the calibration. Most of the SRM plating for FY88 is complete. Part of the effort in this group

the SRM plating for FY88 is complete. Part of the effort in this group is aimed at serving industry through the recertification of coating thickness standards. Thirty-seven coating thickness standards were recertified this last year for 8 corporations.

Wear Resistant Coatings for the Printing Industry

D. R. Kelley, C. E. Johnson, D. S. Lashmore, J. L. Mullen

A two year study of the electrodeposition on engraved currency printing plates for the Bureau of Engraving and Printing (BEP), in collaboration with the Corrosion and Wear Group, was completed. Initially, the program focused on developing an understanding of the process and process variables along with measurement of properties of the electroformed printing plates. Subsequent investigations focused on the characterization of abrasive wear of various chromium electrodeposits and those metallic coatings by laboratory accelerated wear tests and in situ wear tests of BEP. The coatings were obtained by direct current (DC) plating, galvanostatic pulse plating, and by varying operating parameters, such as temperature and current density. Of the myriad of metal, metal alloy, and composite coatings that were investigated for wear performance, seven types of coatings exhibited an increase in wear performance over the current hard chromium technology. The results of wear tests on these coatings, as determined by the laboratory accelerated wear tester, are summarized in figure 12.

A composite coating of nickel-phosphorus-silicon carbide exhibited the lowest rate of wear. This particular coating may have a surface too rough for use on printing plates due to the carrying of ink but warrants further investigation. The majority of the coatings investigated were chromium or chromium based coatings of which six types exhibited an increase in wear performance. The most significant of these was a newly developed pulse plated duplex chromium coating which exhibited a factor of two increase in wear over hard, microcracked chromium. The results of in situ wear testing of chromium plated wiper blades at BEP were two fold. Not only did the in situ wear testing provide a check of the laboratory accelerated tester, but also demonstrated that chromium plating of the wiper blade extended the life of the blade 10 to 15 times the life of the unplated blade. This extended blade life resulted in a dollar savings of \$200,000 per year for BEP.

Electrodeposited Artificial Superlattices

D. S. Lashmore, S. A. Claggett, and R. R. Oberle

Research on electrodeposited artificial superlattices or microlayered alloys has continued this past year with the successful development of electrolytes to produce iron-tin modulated structures. These particular alloys provide the opportunity to examine the vicinity of the interface between each layer using both iron and tin Mossbauer spectroscopy. An optical micrograph of a polished cross section of an iron-tin modulated structure is shown in figure 13.

Magnetic measurements have continued on copper nickel and for the first time a magnetic after effect has been observed in continuous alloys. These measurements are discussed in the magnetic materials section of this report.

This finding is significant as nickel is supposed to relax very rapidly and only nickel is magnetic in this particular alloy. That rapid relaxation clearly does not take place is an indication that there is some interaction between the domain structure across the copper barrier layers. Experiments are now underway to examine magnetic properties of alloys with differing copper-nickel ratio and to investigate any limitations on layer thickness.

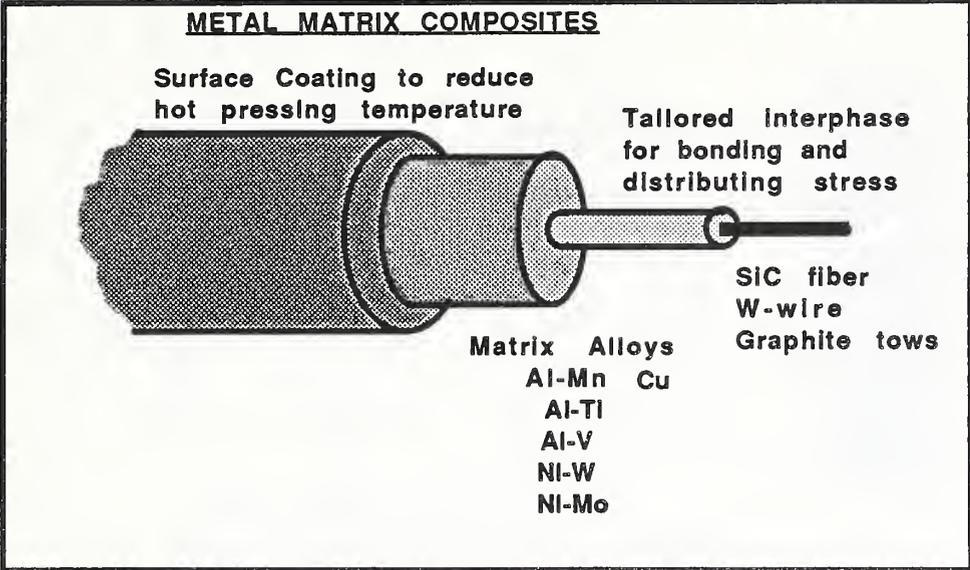

Fig. 1. Idealized Microstructure for a MMC precursor.

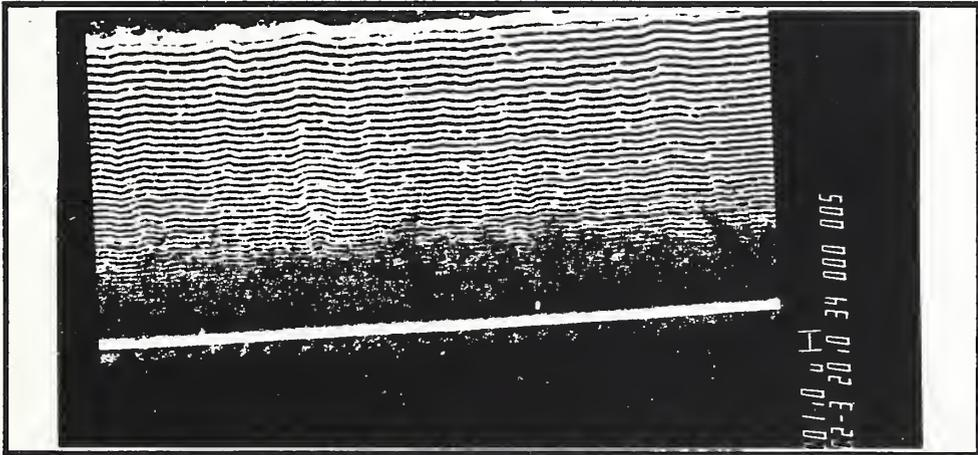

Fig.2a. Optical micrograph of an alloy made up of alternating Ni and Cu layers with a periodicity that varies with thickness.

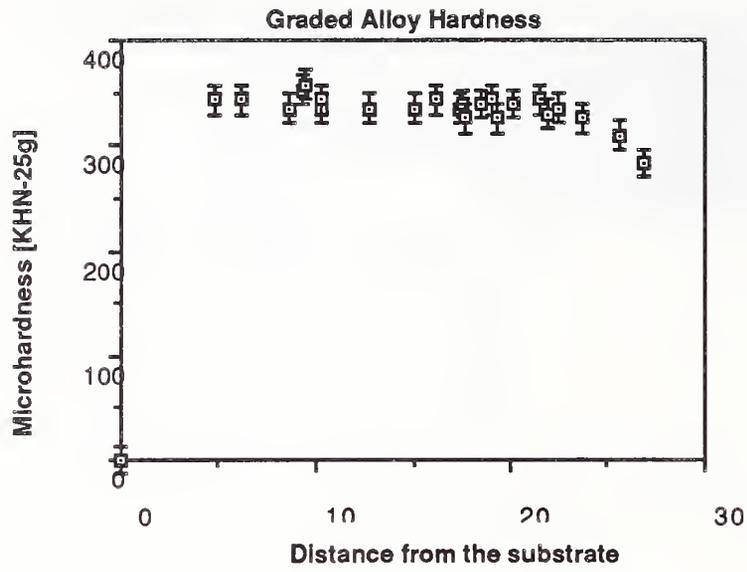

Fig. 2b. The microhardness KHN-10g of the structure shown in Fig. 2a.

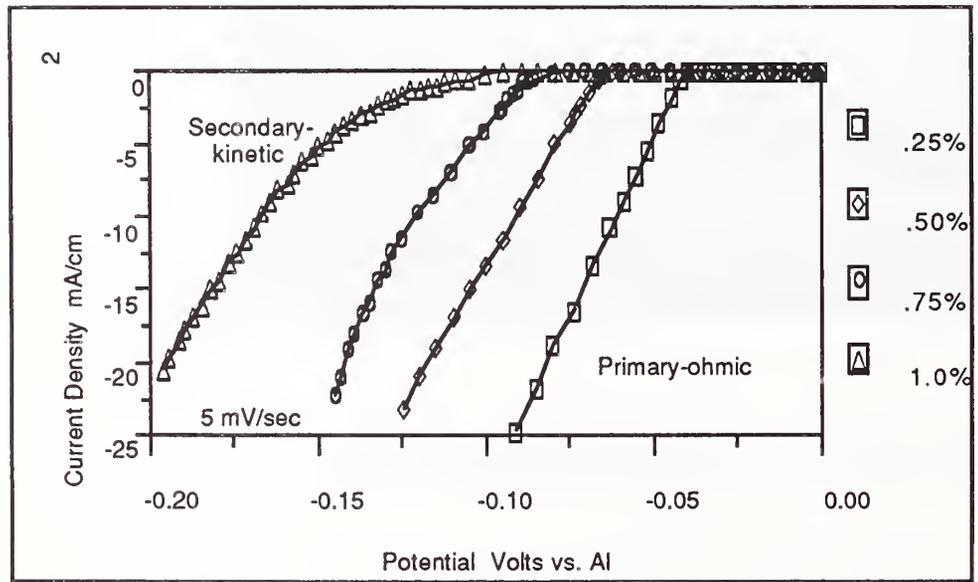

Fig. 3. Linear sweep voltammetry for various MnCl concentrations.

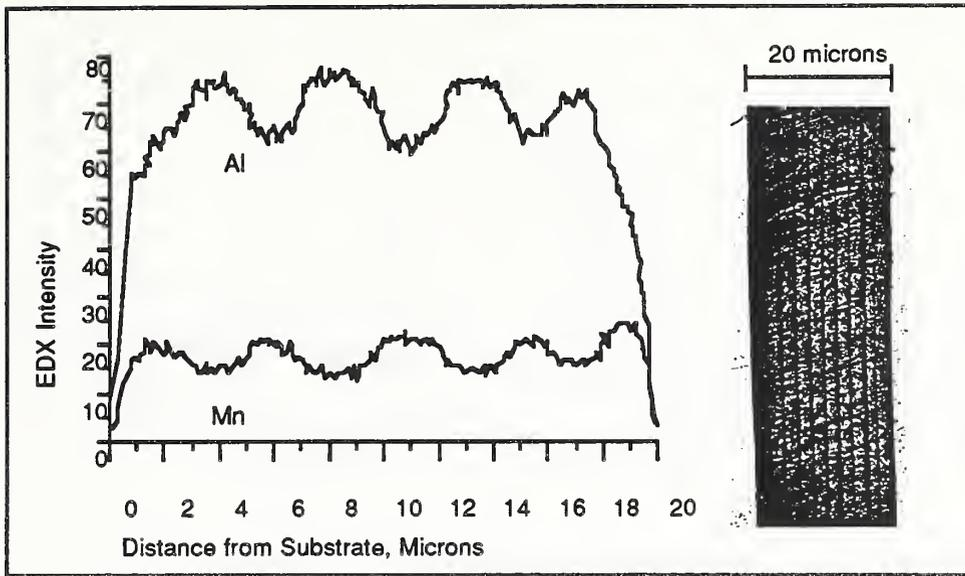

Fig. 4. EDX linescan and polished cross-section of modulated deposit.

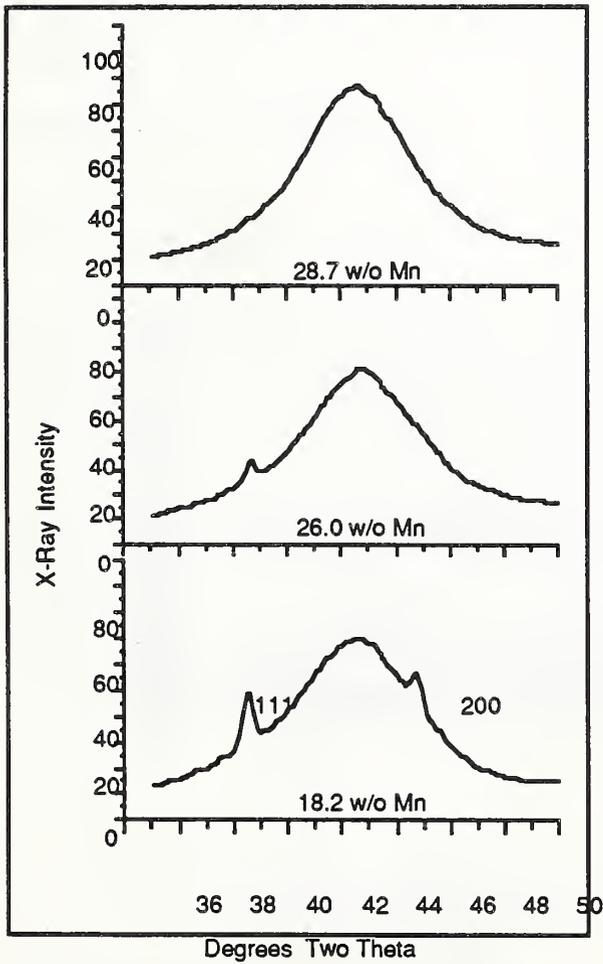

Fig. 5. X-ray diffraction for various electrodeposited aluminum-manganese alloys.

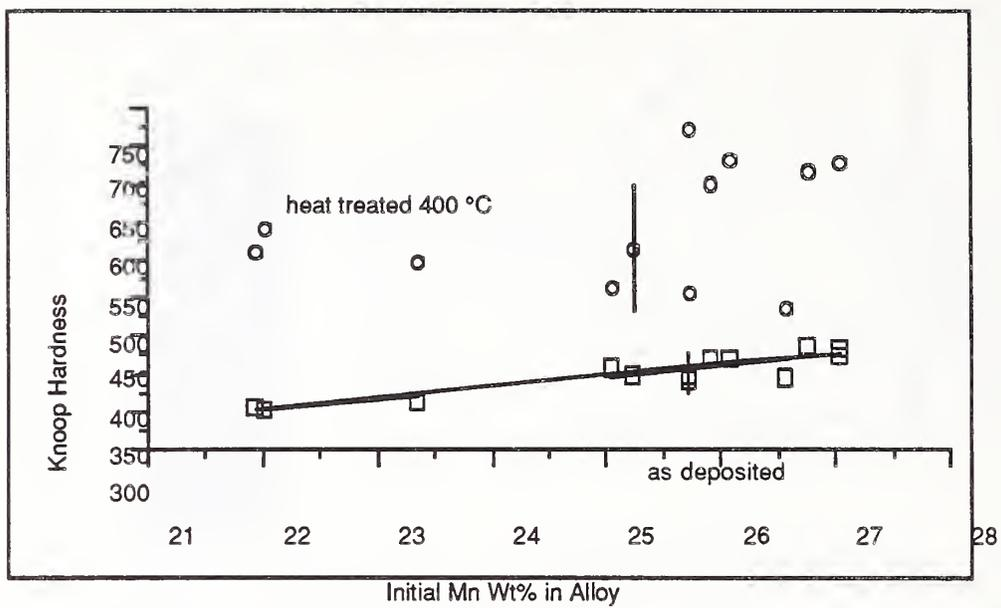

Fig. 6. KHN Hardness data, 10g, vs. alloy composition before and after heat treatment.

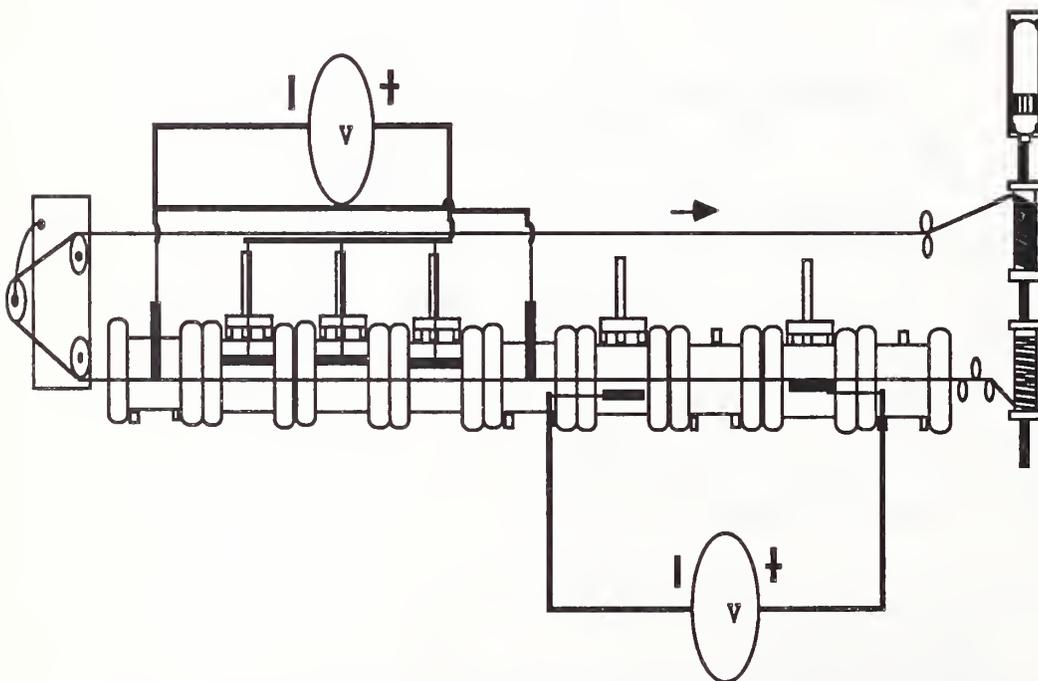

Fig. 7. A schematic diagram of a high speed bench-top cell showing the bipolar electrode and three deposition chambers.

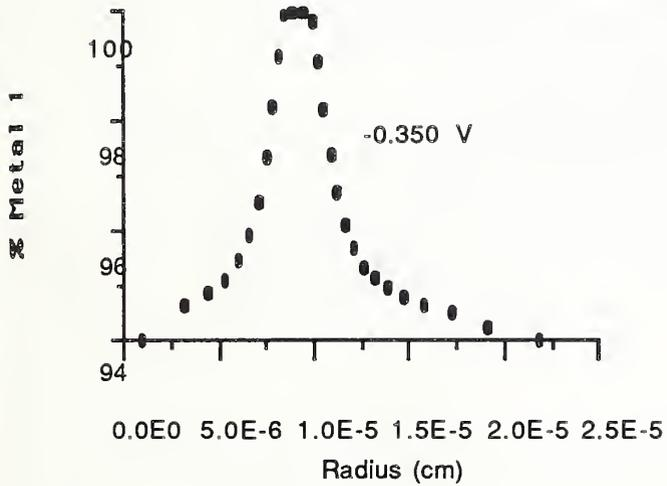
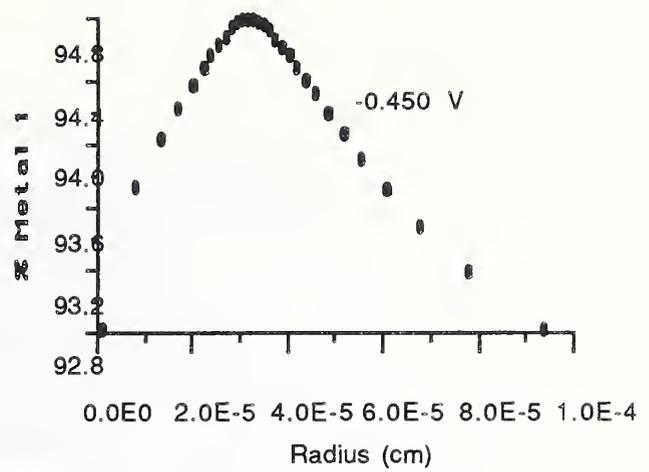
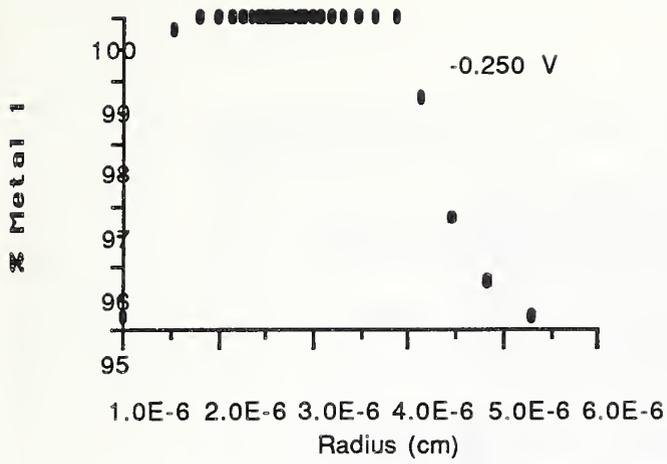

Fig. 8. Radial composition of the alloy for three different applied potentials.

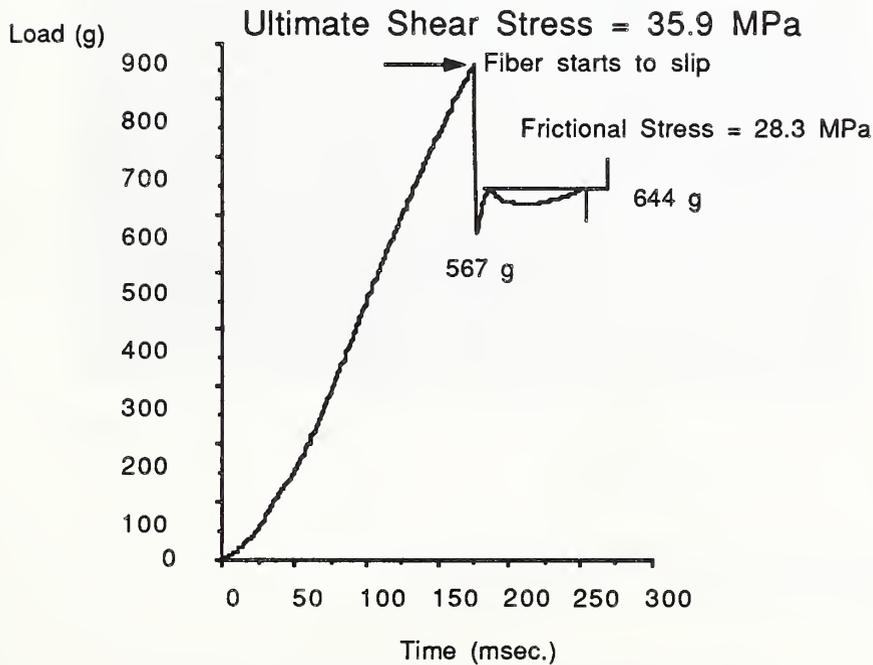

Fig. 9. Load-time curve for a typical adhesion test.

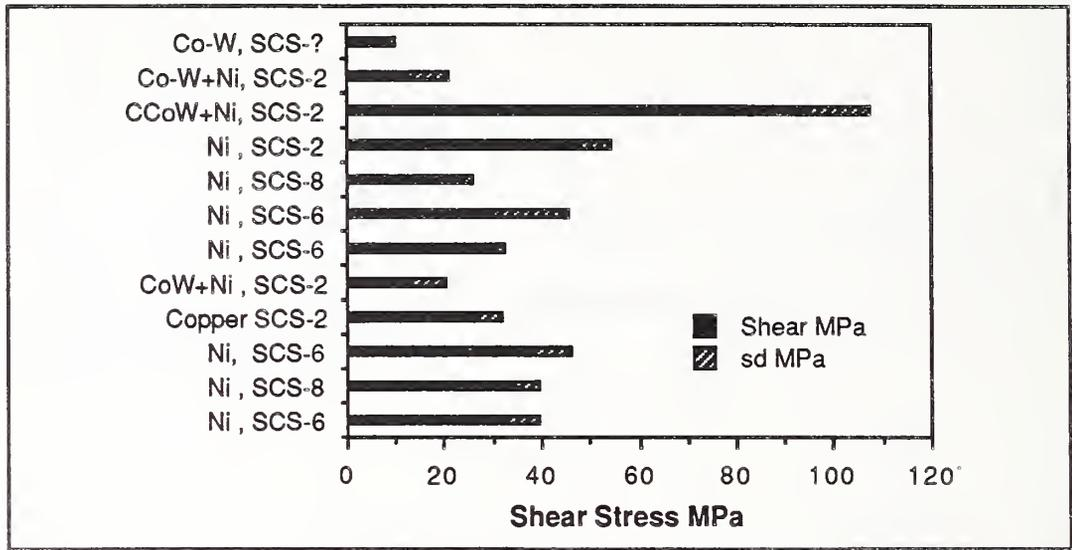

Fig. 10. Examples of adhesion data for a number of coating fiber combinations.

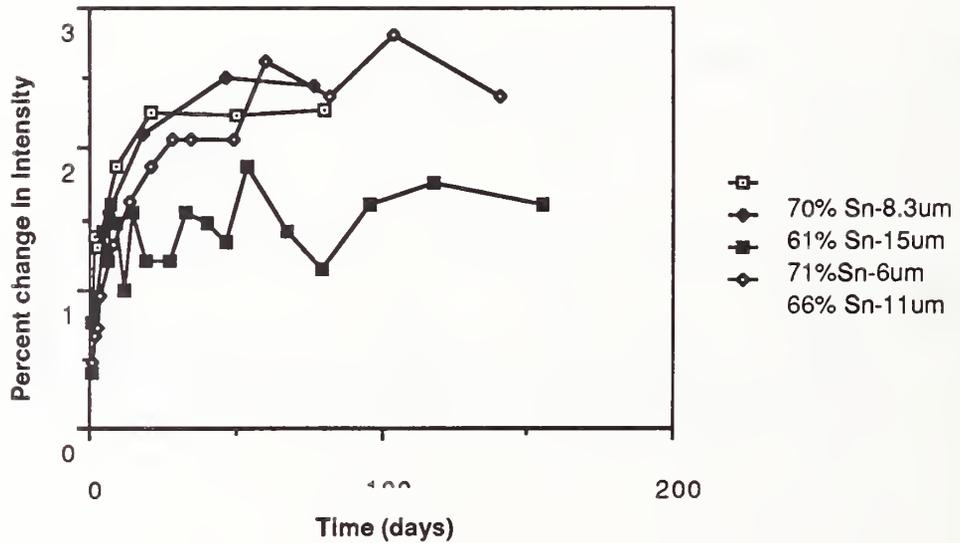

Fig. 11. Example of the variation in x-ray signal as a function of time for electrodeposited solder (Pb-Sn) alloy.

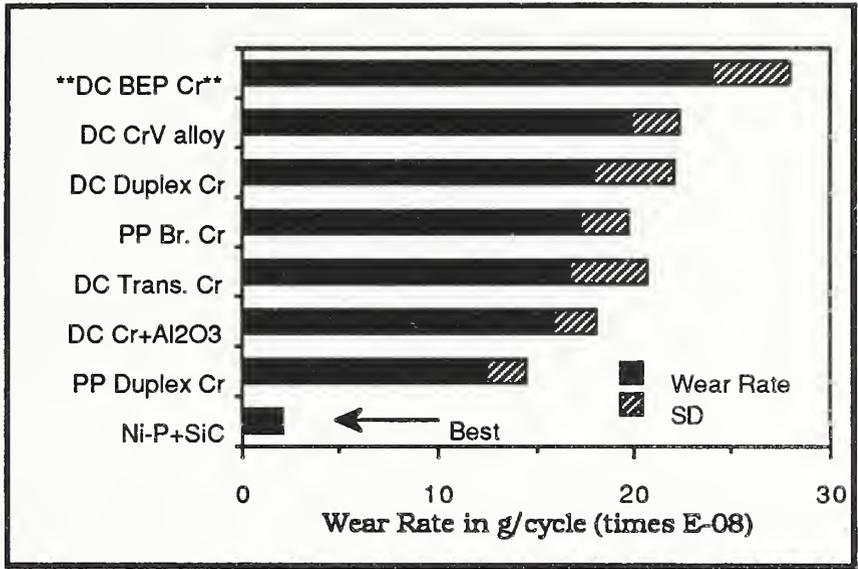

Fig. 12 . Summary of low wear rate deposits compared to the presently used DC deposited chromium as determined by an abrasive slurry wear testing instrument.

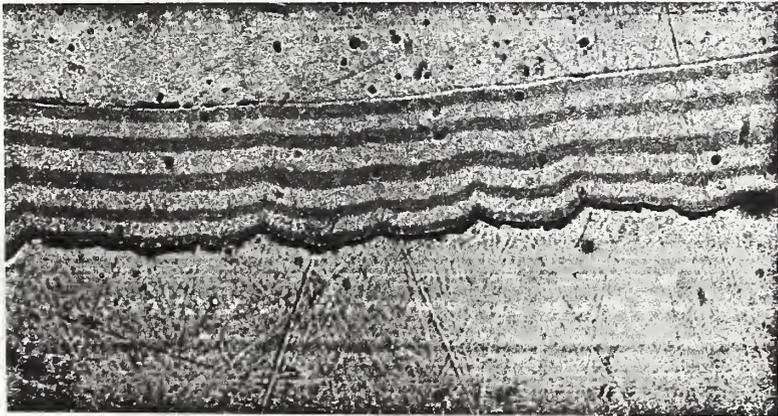

Fig. 13. An Optical micrograph of an Fe-Sn modulated alloy.

The Nondestructive Characterization Group's mission is to advance the measurement science of nondestructive characterization and apply it to the needs of materials science and engineering. Sensors are developed to better control materials processing and understand the fundamentals of transformation and damage mechanisms. The objective of this work is to find ways to better control the artificial structures produced during materials processing. One way this can be achieved is with a future generation of sensors able to directly measure the process conditions and microstructure features of importance. This will permit computerized controllers (some of which will feature artificial intelligence expert systems) to adjust the process to produce a constant product in the most cost-beneficial manner even with varying raw materials.

A collaborative project with the Extruded Products Committee of the Aluminum Association has resulted in a prototype eddy current sensor that was able to measure "body" temperature during trials at Cressona's extrusion mill at Cressona, PA. Work is continuing with the Association to identify a prospective vendor, and explore ways of deconvolving temperature gradients from the sensor data. A modified version of the sensor has been used to measure in situ dimensional changes during hot isostatic pressing (HIPing) of aluminum and copper up to 550°C and 50 MPa. This DARPA funded program has opened the way for new control schemes for HIPing and close interaction is continuing with the Metallurgy Division's processing group to explore development of an artificial intelligent (AI) controller for this process.

Research with the ultrasonic temperature sensor are continuing. Efforts to extend successes with solid body internal temperature profiling to solidifying bodies required that the problems of "breakout" and failure to achieve acoustic paths due to poor wetting in the prototype experimental system be solved. A new method for simulating continuous caster solidification has recently been designed and constructed, and data from liquid/solid bodies is now being analyzed. The ultrasonic porosity sensor completed in FY 1986 for the steel industry has this year been the recipient of an IR-100 award.

Sensor research has been complemented by other programs directed at applying nondestructive characterization methods to the study of phase transformation and damage mechanisms. Research on ultrasonic methods to probe interfaces in composites has proceeded rapidly with the theoretical prediction and experimental verification of localized modes in several fibrous metal matrix composites (Al-SiC, Al-B₄C, Al-B, Al-Graphite). Present research is investigating the role of an interphase (such as aluminum carbide between a SiC fiber and an aluminum matrix) on wave propagation and developing methods to image interfaces (this in collaboration with Professor B. T. Khuri-Yakub of Stanford University). Other ultrasonic studies are being used to investigate internal friction phenomena in high temperature superconductors near their T_c, and to attempt detection of "threading" dislocations emanating from Si-GaAs interfaces - this latter in collaboration with Martin Marietta Laboratories.

Acoustic emission techniques have been coupled with high resolution mechanical property tests to measure interfacial cohesion in aluminum-SiC fiber composites. By using special samples containing only a single oriented fiber, many of the complexities of this measurement challenge have been overcome. Work is now progressing to explore the role of processing time and temperature upon the interface strength and the effect of this upon damage mechanisms in metal matrix composites. The feasibility of imaging with the Mossbauer effect has been established. This will provide a potentially new way to noninvasively probe the microstructure of materials.

During FY 1987 collaborations and interactions with industry and academia have continued to increase. Cooperative research programs with the American Iron and Steel Institute, the Aluminum Association, Johns Hopkins University and MIT (advanced composites) has continued. Ygal Gefen has spent a very fruitful year with us while on sabbatical from Israel. New collaborations with Professor B. T. Khuri-Yakub of Stanford to explore acoustic imaging of MMC interfaces, and the Martin Marietta Laboratory at Baltimore to explore the feasibility of in situ detection of interfacial dislocations during molecular beam epitaxial growth of III-V compound semiconductor thin films on Si substrates. Interactions with other Government agencies, notably ONR and DARPA have been extended both to conduct research and provide program development advice. A joint ASM-AIME symposium on "Intelligent Processing of Materials and Advanced Sensors" held at the AIME-TMS Fall Meeting in Orlando was organized.

FY 87 Significant Accomplishments

- o A collaborative NBS/Aluminum Association program has resulted in the successful testing of a prototype eddy current sensor for determining body temperature of aluminum during extrusion.
- o An eddy current sensor has been developed to sense density (in situ) during hot isostatic pressing of aluminum, copper, and high T_c superconductors.
- o A single crystal aluminum-SiC fiber sample preparation and mechanical testing approach has been perfected to allow fundamental studies of interfacial effects on fracture of metal matrix composites. This approach has allowed determination of the role of processing variables on the cohesion and load transfer properties of Al-SiC composites.
- o Ultrasonic waves have been theoretically predicted and experimentally confirmed to be supported at the cylindrical interfaces of aluminum-SiC fibrous composites. By exploiting the "leaky" character of these waves, it has been found possible to measure local differences in ultrasonic velocity thus creating the potential for interphase imaging.
- o The concept of Mossbauer imaging has been recognized for the first time. An imaging formulation has been developed and implemented successfully in one dimension.

Eddy Current Sensing - Temperature Measurement of Aluminum During Extrusion Processing

A. H. Kahn, M. L. Mester*, and H. N. G. Wadley

* Research Associate, The Aluminum Association

Design and construction of a prototype model of an eddy current sensor for measuring, every few seconds, the diameter, electrical conductivity, and the temperature of aluminum rod during extrusion processing has been completed. A plant demonstration and test were conducted in July 1987. This project has been conducted as a joint effort of the Metallurgy Division, the NBS Office of Nondestructive Evaluation program and The Aluminum Association (a consortium of manufacturing and processing companies). The impetus for its undertaking has been the objective of improved product quality and reduction of rejected output through in-process temperature measurement and control. The envisioned control system will use sensor acquired temperature measurements in a feedback loop, performing off-line control of the initial temperature of the aluminum billets and on-line control of the speed of extrusion (itself a heat-generating process). The function of the temperature measurement in the control loop is shown in figure 1.

The prototype model is based on the use of a commercially available Impedance/Gain-Phase Analyzer, with measurement initiation and recording of data performed by a personal computer. Later, an application specific design, requiring less versatility than needed for the development phase, could lead to a smaller device capable of even more rapid measurement. A block diagram of the prototype circuit is shown in figure 2. It is seen from the figure that the measurement of the properties of the test sample is obtained from the transfer impedance between the primary and secondary circuits. An audio power amplifier is placed in the primary circuit to enhance sensitivity, particularly at the lower frequencies. From the impedance measurements are obtained the diameter and conductivity of the aluminum rod. Since the electrical conductivity of the test material is a continuously decreasing function of temperature which may be measured for the alloy under study, the impedance measurement provides the data required to deduce temperature. In laboratory tests the instrument measured the temperature of heated aluminum rods to within $\pm 5^{\circ}\text{C}$, at the rate of one measurement per 1.25 sec.

The plant tests took place at the Cressona Aluminum Co., Cressona, PA. The sensor was placed within one foot of the die in the extrusion press. Temperatures were measured during operation on round and square solid stock, and also on hollow square tubing. Figure 3 shows a plot of measured temperatures of 3/4 inch square solid stock as a function of time as the speed of extrusion was intentionally varied. Factors influencing the temperature are the temperature of the part of the billet being pressed through the die and friction in the die, which generates heat. These effects are seen in the figure. Cooling at the end of the process begins when the extrusion was cut and the product transported away from the press.

Eddy Current Sensing - Measurement of Density During Hot Isostatic Pressing

A. H. Kahn, Y. Gefen**, M. L. Mester*, R. B. Clough and
H. N. G. Wadley

* Research Associate, The Aluminum Association

** Guest Scientist

In a DARPA cofunded project similar instrumentation to that used for the aluminum extrusion sensor has been applied to the measurement of density of metallic powders during sintering in a pressure furnace. The powder being consolidated is sealed in an evacuated metallic tube and the tube is placed in the furnace in the center of the concentric sensor coils. From impedance measurements at high frequencies it is possible to infer the cross-sectional area of the material being tested. As the powder is consolidated the tube diameter decreases and a reading of diameter during the process can be obtained. An example for a run on copper powder sealed in copper tubing is shown in figure 4. This monitoring of the process enables one to test theoretical models for sintering. The method shows promise for the design of intelligent feedback control of temperature and pressure to optimize special properties of the material being sintered.

Steel Sensors

M. Linzer, F. A. Mauer, D. Pitchure, S. J. Norton, J. R. Cook*, R. L. Heinrich**, and H. N. G. Wadley

* Research Associate, American Iron and Steel Institute

** Contractor at NBS

In 1982, a workshop sponsored jointly by NBS and the American Iron and Steel Institute (AISI) identified a need for four types of sensors for use during automated process control in the steel industry. Scientists from NBS and AISI have collaborated in the development of two of these, one for automatic detection of pipe and gross porosity in hot steel billets, blooms, or slabs and the other for measurement of the temperature distribution within a solid or solidifying body of hot steel. Both are based on ultrasonic measurement techniques.

Success in developing the pipe and porosity sensor depended on finding a way to couple a sensitive piezoelectric transducer to a moving strip of hot steel so that intense ultrasonic pulses could be transmitted into the steel and echoes from internal discontinuities received. At the same time, thermal insulation had to be incorporated between the hot steel and the transducer. A buffer in the form of a rolling wheel was developed by Magnaflux Corporation of Chicago to meet these requirements. In the past, such wheel buffers have required pressures of as much as 140 MPa to achieve ultrasonic coupling. A key NBS contribution has been the development of a high temperature couplant to enhance the transmission of ultrasonic waves and eliminate the need for heavy pressures that could result in damage to the product.

Tests at NBS and The Argonne National Laboratory in FY 1987 have confirmed the sensor's ability to detect and measure internal porosity and flaws in hot steel during processing, enabling steel producers to crop unsound material early in the production cycle (the AISI has estimated the potential savings at \$1M per year for each installation using the sensor). The new sensor has recently received recognition in the form of the IR-100 award. NBS and Argonne are jointly applying for a patent for the technique, and Magnaflux Corporation is currently manufacturing sensors for the steel industry.

NBS has developed an internal temperature sensor in collaboration with scientists from the AISI. The system, based upon time of flight measurement, has been fully automated using two arrays of ultrasonic receivers, each consisting of five piezoelectric transducers coupled to the test body through buffer cones of AISI 304 stainless steel. These are to be replaced later with non-contacting EMAT's (Electromagnetic Acoustic Transducers).

An improved method for determining small changes in the time of flight (TOF) has been adopted which is particularly useful when the wave arrival is obscured by high-frequency noise. The method is based on cross correlating each high-temperature waveform with one recorded for a corresponding path at room temperature. The shift on the time axis that gives the maximum value of the cross correlation coefficient gives the change in TOF between room temperature and the higher temperature.

Recent tests on a six-inch square block of AISI 304 stainless steel showed excellent agreement between the ultrasonic temperatures and the temperatures indicated by an embedded thermocouple at the center of the block (figure 5). Linear regression analysis gave $T_{TC} = 3.9 + 0.997 T_{US}$ as the expression relating thermocouple readings, T_{TC} , and ultrasonic temperature readings, T_{US} , indicating that calibration corrections do not exceed 5°C.

A ten-channel ultrasonic system is being used for measuring temperature fields and locating the solid/liquid interface in solidifying bodies. Difficulty was experienced in simulating a solid shell with a liquid core in the laboratory. Attempts to pour molten aluminum into a preformed shell resulted either in a breakout of the liquid or failure of the liquid to wet the solid as required to form a continuous ultrasonic path. Solidification times (and thus the quantity of data that could be collected) were also very limited. The present approach permits the core to be heated in place with electric heaters. This system provides better control so that a portion of the solid at the interface can be melted to remove any oxide before allowing the solidification front to advance or even be held stationary.

The amplitude of the ultrasonic signal obtained with aluminum is at least five times as great as that obtained with steel and the rise time of the received pulse is so short that a faster transient recorder is needed to adequately represent the waveform. A transient recorder with a sampling interval of 5 nanoseconds has been obtained to replace the 32 nanosecond units presently in use. This instrument, combined with the cross-correlation algorithm, promises to further reduce the scatter in measured values of TOF, permitting an improvement in the precision of temperature profiles and the resolution of solid/liquid interface.

Interface Characterization in Metal-Matrix Composites

J. A. Simmons, E. Drescher-Krasicka**, M. Rosen**, T. Hsieh**,
B. Elkind**, R. B. Clough, R. P. Quincoses, F. S. Biancaniello, and H. N. G.
Wadley

** Guest Scientists, Johns Hopkins University

The mechanical performance of metal matrix composites is strongly dependent on interfacial elastic and anelastic properties and strength. In order to measure these properties in situ, advanced traditional non-destructive test methods have been developed. To isolate the phenomena and avoid additional complications arising from multiple reinforcement elements, such as complex stress states, model metal matrix composites were fabricated as acoustic heterojunctions with planar and cylindrical geometries.

In the planar geometry, using Fe-Ti, experiments determined the substantial effect of microstructure and stress on the velocity of interface waves. These experiments showed the feasibility of generating interface waves other than pure Stoneley waves at planar acoustic heterojunctions by mode conversion of Rayleigh waves on the more dense medium, Table 1.

Weakly leaky ultrasonic guided interface waves (G.I.W.'s) in the cylindrical geometry have been found to provide a new tool for interface characterization in fiber reinforced composites, and have led to a preliminary design for a new type of acoustic microscope. The leakage from these modes offers the opportunity for measurement of the quantities of interest: local elastic properties, defects and adhesion directly at the interface. As a leaky wave travels along an interface, it radiates acoustic energy out of the interface. Measurements on Al/stainless steel (figure 6) and Al/SiC cylindrical interfaces show good agreement with the theoretically predicted arrivals of radial-axial leaky interface modes. The elliptical particle trajectories in these figures show the relative amplitudes of horizontal and vertical displacement components. The continuous thick lines show the energy path followed by a wave packet emanating from the interface as found by integrating the Poynting vectors. The results show good agreement between the measured points and calculated (continuous lines) of maximum flow of acoustic energy due to leakage.

The calculated displacement field of the leaky radial axial G.I.W. for the Al/SiC interface superimposed on the geometry of the sample is shown in figure 7. This mode was detected on Al/SiC model samples and the dispersion relation obtained for different frequencies used in the experiment agrees with theoretical predictions [1]. Another weakly leaky mode at Al/SiC interfaces was measured (points) and compared with the theoretical predictions (continuous line), figure 8. The phase velocity of the mode measured as a function of frequency agrees with the calculations and is surprisingly high (18653 m/sec at 3 MHz and a fiber radius of 3.2 mm). This mode was first detected, analyzed and separated from the other ultrasonic arrivals by use of an acoustic microscope at Stanford University.

From these results, a new instrument for studying the elastic properties near the interface zone is presently under preliminary development, figure 9. This Interface Wave Acoustic Microscope uses leakage from the interface for interface imaging.

The fiber and interface strength of model composites was measured in instrumented tensile tests that were simultaneously monitored by acoustic emission. The model composites consisted of a single fiber of SiC grown into a single crystal of aluminum.

Single crystal Al, monofilament (SCS-2 type) SiC composites were fabricated using a Bridgman-type technique. There were four types of specimen: rapidly and slowly grown, with and without a carbon-rich fiber surface preparation. As the composite (with a single fiber) is extended, it exhibits load drops in the stress-strain curve. Measurement techniques have now been developed to allow determination of fiber strength from the magnitude of these load drops.

The interfacial shear strength τ and fiber tensile strength σ_f in fiber composites subjected to longitudinal loading are related by the formula: $\tau = \sigma_f l_c / 2d$, where d and l_c are respectively the fiber diameter and segment length after fiber breakup is complete (the "critical length"), measured by post-test metallography. By measuring each term on the right hand side of this equation, the interface strength σ_f can be determined. The results are shown in Table 2. Fiber surface modification by carbon enrichment was effective in maintaining fiber strength and interface adhesive energy. Rapidly cooling the specimens from the melt also minimized fiber and interface degradation. There is evidence in the case of slowly cooled materials, where the interface strength is less than the matrix strength, that interfacial failure of a shear type occurred, i.e., by frictional slip or fracture.

Acoustic emission measurements provided results in agreement with those deduced from tensile tests, figure 10. The rapidly cooled composites showed direct correspondence between the number of fiber fractures (as measured by post-test metallography) and the number of acoustic emission events. The interface strength was not less than the matrix strength, so that interfacial failure was by plastic flow in the matrix. In contrast, the more slowly cooled composites exhibited a substantial number of events in excess of the number of fiber fractures, which were also much more energetic than those from plasticity. These are attributed to interfacial failure, and metallographic examination of the interface region shows the development of interfacial cracks.

Reference:

- [1] H. N. G. Wadley, J. A. Simmons, E. Drescher-Krasicka, M. Rosen, R. B. Clough, T. Hsieh, K. Hirschman, F. S. Biancianiello; Composite Materials Interface Characterization, NBS Internal Report # 87-3630

Dislocation Measurement in Thin-Film Semiconductors

W. L. Johnson and H. N. G. Wadley

A collaborative project has been initiated with researchers at Martin Marietta in Baltimore, MD. with the goal of developing a technique for continuously monitoring dislocation concentrations in epitaxial films during molecular beam epitaxy (MBE) growth at $\sim 600^\circ\text{C}$. The technique is to be used initially as a tool in the development of a variety of high-speed semiconducting films, such as GaAs on Si, free of the degrading effects of dislocations. It may also be used for in-process quality control once these materials reach commercial production.

The internal friction of the film/substrate wafer is being monitored. Although internal friction data specific to these materials are incomplete, it appears, from existing data on semiconductors that the attenuation always increases exponentially with negative inverse temperature and linearly with dislocation concentration. The attenuation, therefore, provides a measure of dislocation concentration once the appropriate constants have been determined for a given material. In order to perform the measurement, the wafer will be supported by three needle points and set into forced vibration with a contactless capacitive drive. The drive voltage will then be turned off and the decaying oscillations monitored. A feasibility study and initial design of the system have been completed.

Mossbauer Imaging

S. J. Norton and L. H. Bennett and L. J. Swartzendruber

A novel imaging technique based on the Mossbauer effect has been proposed [1] and experimentally demonstrated [2]. Recoil-less gamma-ray resonance, or the Mossbauer effect, is a well-established spectroscopic tool in materials science. A conventional Mossbauer experiment measures only a bulk average of the gamma-ray resonant absorption coefficient over an absorbing specimen. Thus spatial inhomogeneities within an extended absorber are lost in the bulk measurement process. Mossbauer imaging, however, permits the reconstruction of the two-dimensional spatial distribution, or an image, of the Mossbauer absorption coefficient. In a more complex version of an imaging experiment, spectroscopic information as a function of position is recoverable. As a consequence, in the latter version, true Mossbauer spectroscopy can be performed for the first time in an imaging mode.

The idea of Mossbauer was inspired by the success of nuclear-magnetic-resonance imaging, since NMR and the Mossbauer effect share some fundamental characteristics, both being nuclear resonance phenomena. NMR imaging has recently found notable success in diagnostic medicine. While there are no foreseeable applications of Mossbauer imaging to medicine, applications in materials science are thought to exist. The ability to perform Mossbauer spectroscopy as a function of position within a sample, rather than in bulk, should prove to be of value in the analysis of heterogeneous or composite materials. Some potential high-resolution applications include the imaging of grain boundary segregation, internal stress distributions, and magnetism in ferromagnetic materials.

References:

- [1] Mossbauer Imaging, S.J. Norton, Nature (in press).
- [2] Mossbauer Imaging: Experimental Result, U. Atzmony, S. J. Norton, L. J. Swartzendruber, L. H. Bennett, Nature (in press).

Iterative Inverse Scattering

S. J. Norton

A general numerical approach to solving the exact, nonlinear inverse-scattering problem has been developed [1]. Most current inverse-scattering algorithms or analytical inversion schemes are based on linear approximations (e.g., the Born approximation) to the more exact, nonlinear inverse-scattering theory. These approximations fail to account for the distortion of the internal wave field interacting with the scattering structures. Such distortion, including multiple reflection and refraction effects, can often be neglected in weakly scattering media (Born approximation), but such effects are frequently significant in strongly scattering media. Two well-known iterative algorithms, steepest descent and conjugate-gradient descent, are used to solve the exact, nonlinear inverse-scattering problem from scattering data by minimizing the mean-square error between the observed data and data generated by the estimated scattering model. This approach offers great flexibility, both in incorporating a priori information and in its ability to weight the measurements in an optimal fashion based on error statistics, which serves also to regularize an otherwise ill-conditioned inversion. In minimizing the mean-squared error, many authors have proposed Newton-like methods, but the above descent algorithms have superior global convergence properties and avoid the need to invert a large matrix containing second-derivative information. The problem can be formulated so that the first iteration gives the Born inversion.

In all iterative approaches the gradient of the measurements with respect to the model plays a fundamental role. An approximation to the gradient is almost always derived by linearizing the measurement-model relationship (the Lippmann-Schwinger equation), resulting in a gradient correct only to first-order in the perturbation. Weston [J. Math. Phys. 20, 53-59, 1979] has obtained an exact expression for the gradient, correct to all orders in the perturbation, in the special case of monochromatic plane-wave illumination and far-field detection. In the current work, Weston's results have been generalized to the time domain and to point sources and receivers. In a one-dimensional numerical simulation of the nonlinear inverse-scattering problem, the exact gradient has been shown to improve both the rate and stability of convergence of the inversion algorithm to the correct solution. Work on extending the numerical simulations to two and three dimensions has begun. Future work will include generalizing the current scalar-wave, inverse-scattering theory to elastic-wave scattering.

Reference:

- [1] Iterative Seismic Inversion, S. J. Norton, Geophys. J. R. Astr. Soc. (submitted).

ALUMINUM EXTRUSION TEMPERATURE SENSOR

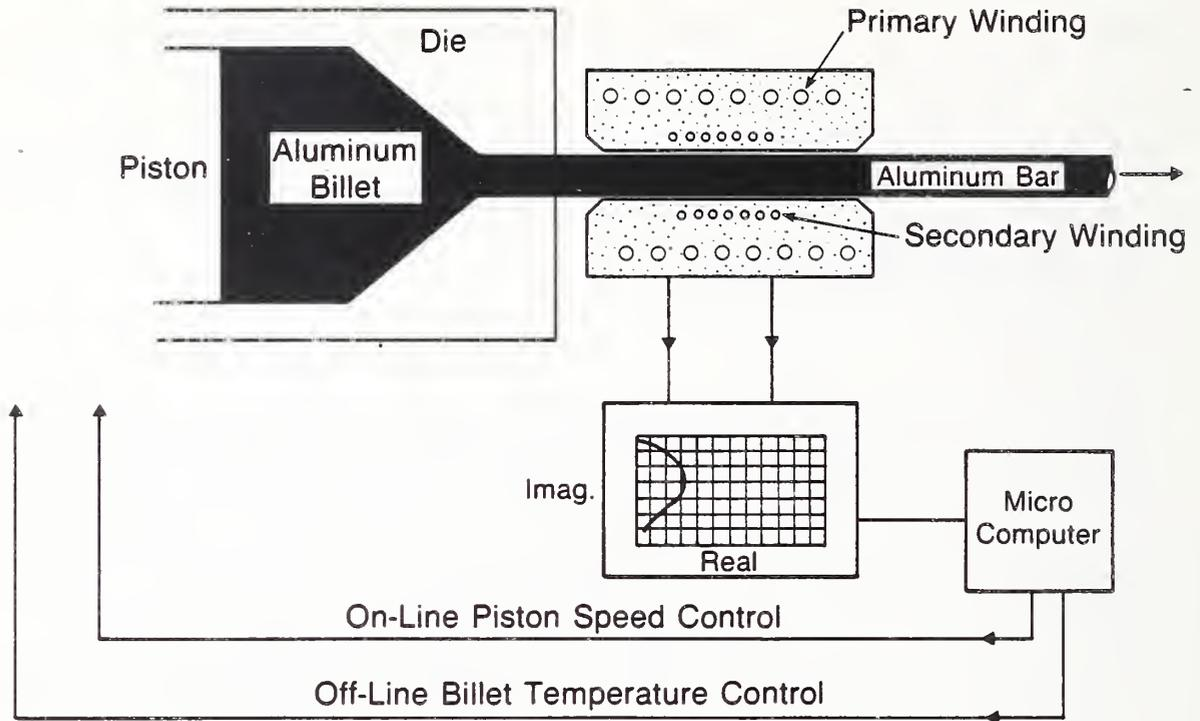

Figure 1. Schematic illustration of the proposed use of the eddy current temperature sensor in a feedback loop controlling extrusion processing.

IMPEDANCE ANALYZER GAIN/PHASE MODE OPERATION

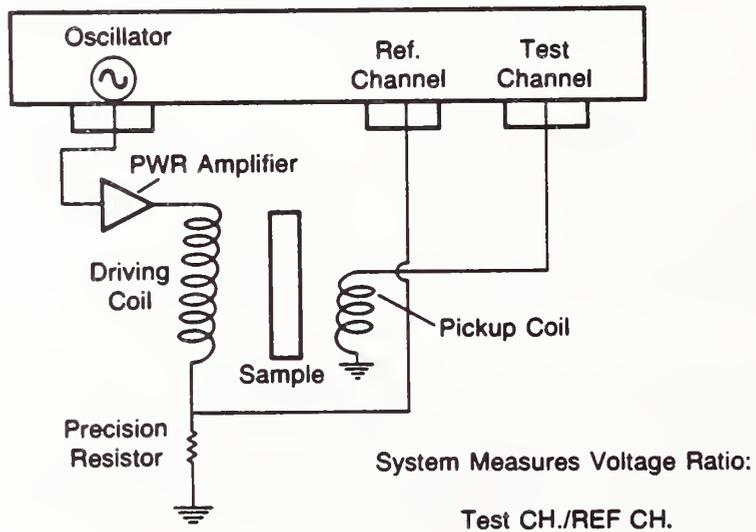

Figure 2. Circuit diagram of the use of an impedance/gain-phase analyzer to measure electrical resistivity by a non-contact method. The two coils are concentric solenoids; the test sample is passed through the coil system.

3/4 X 3/4 SQUARE AT VARIED SPEEDS

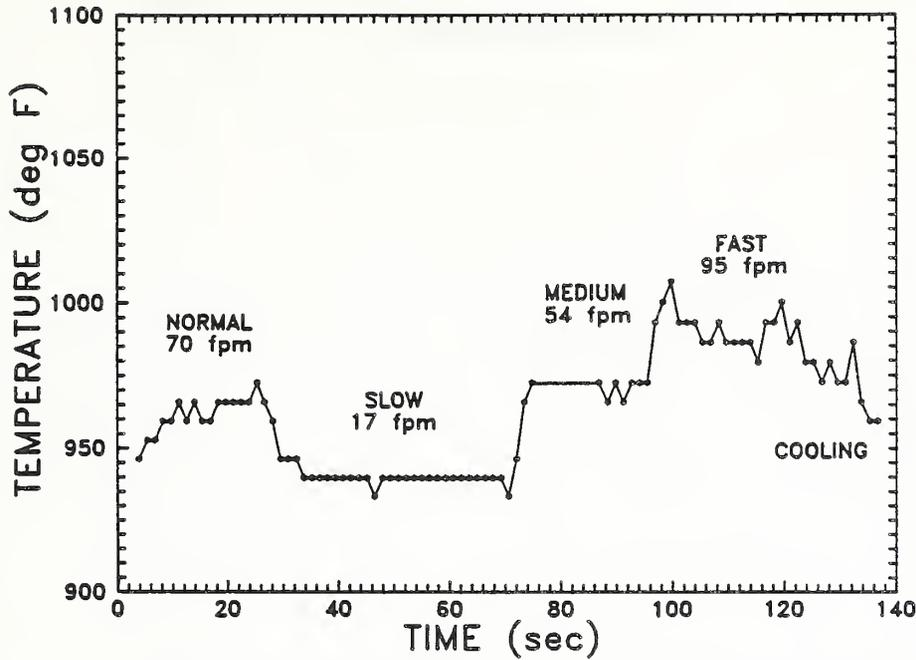

Figure 3. Record of temperature measurements on 3/4 square stock during extrusion processing. Extrusion speed was intentionally varied for demonstration purposes.

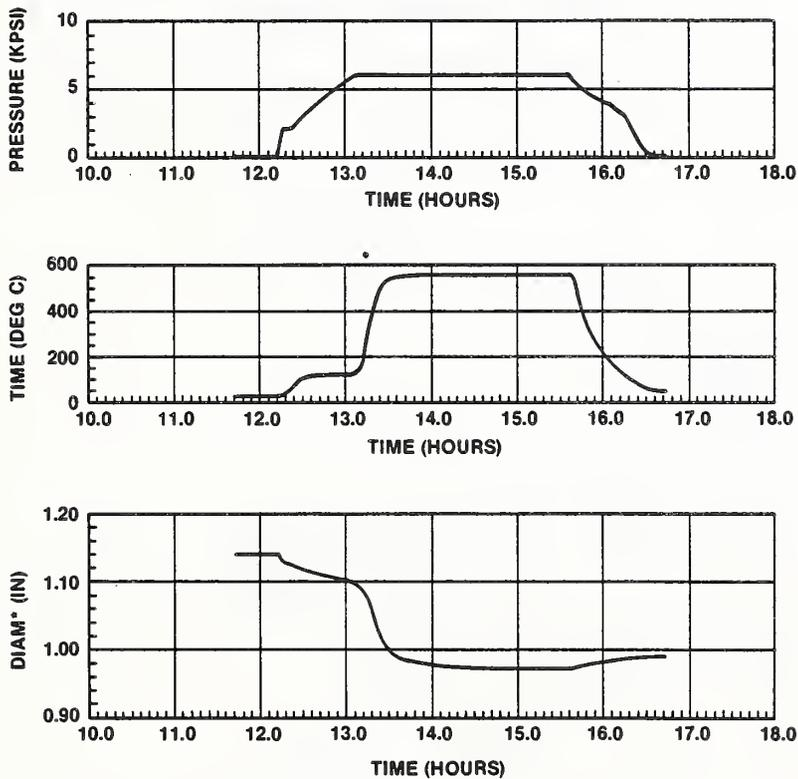

Figure 4. Plots of pressure, temperature, and relative density vs time for a HIP (hot isostatic pressing) run on copper powder sealed in a copper tube. The relative density was calculated from diameter measurements collected by the eddy current sensor.

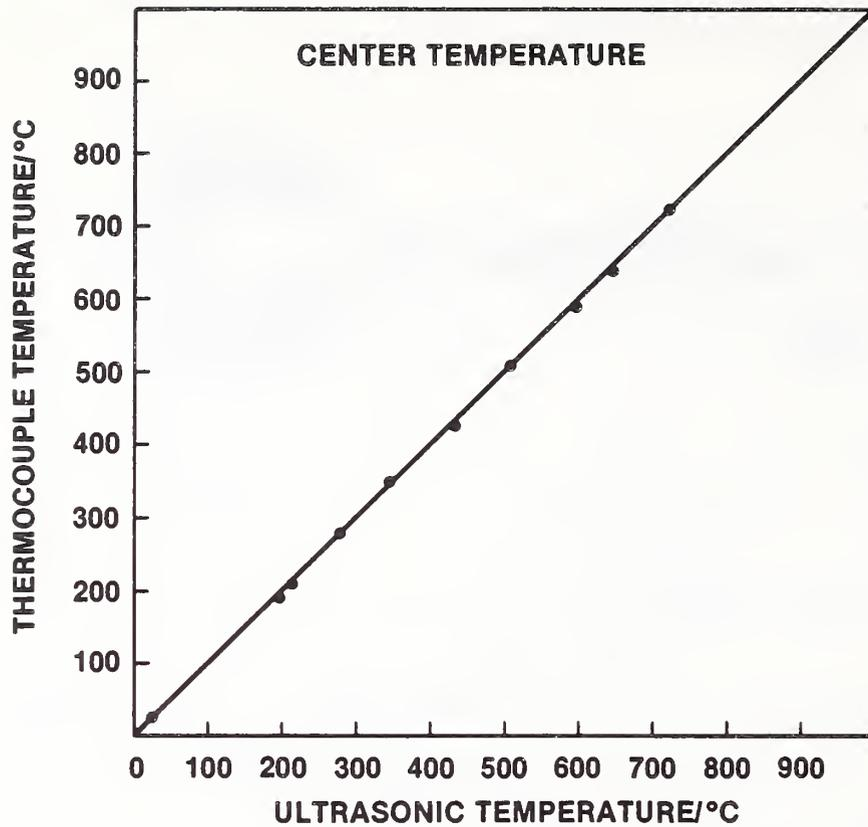

Figure 5. Comparison of temperature at center of steel block measured by ultrasonic cross-correlation technique and embedded thermocouple.

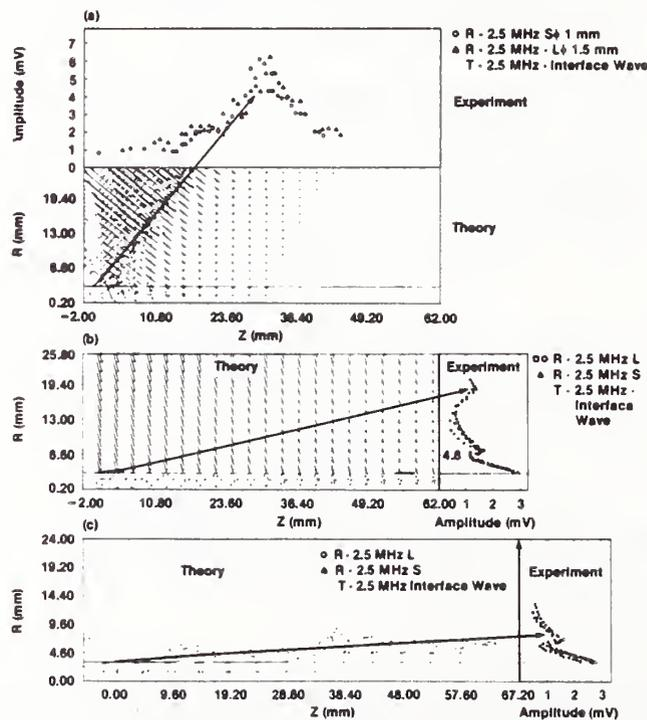

Figure 6. Experimental identification of three leaky radial-axial displacement modes created in a 3.2 mm radius cylindrical aluminum "tunnel" of 62 mm length. Experimental intensity profiles of leakage at the top and end surfaces are shown superimposed with calculations for each of the modes.

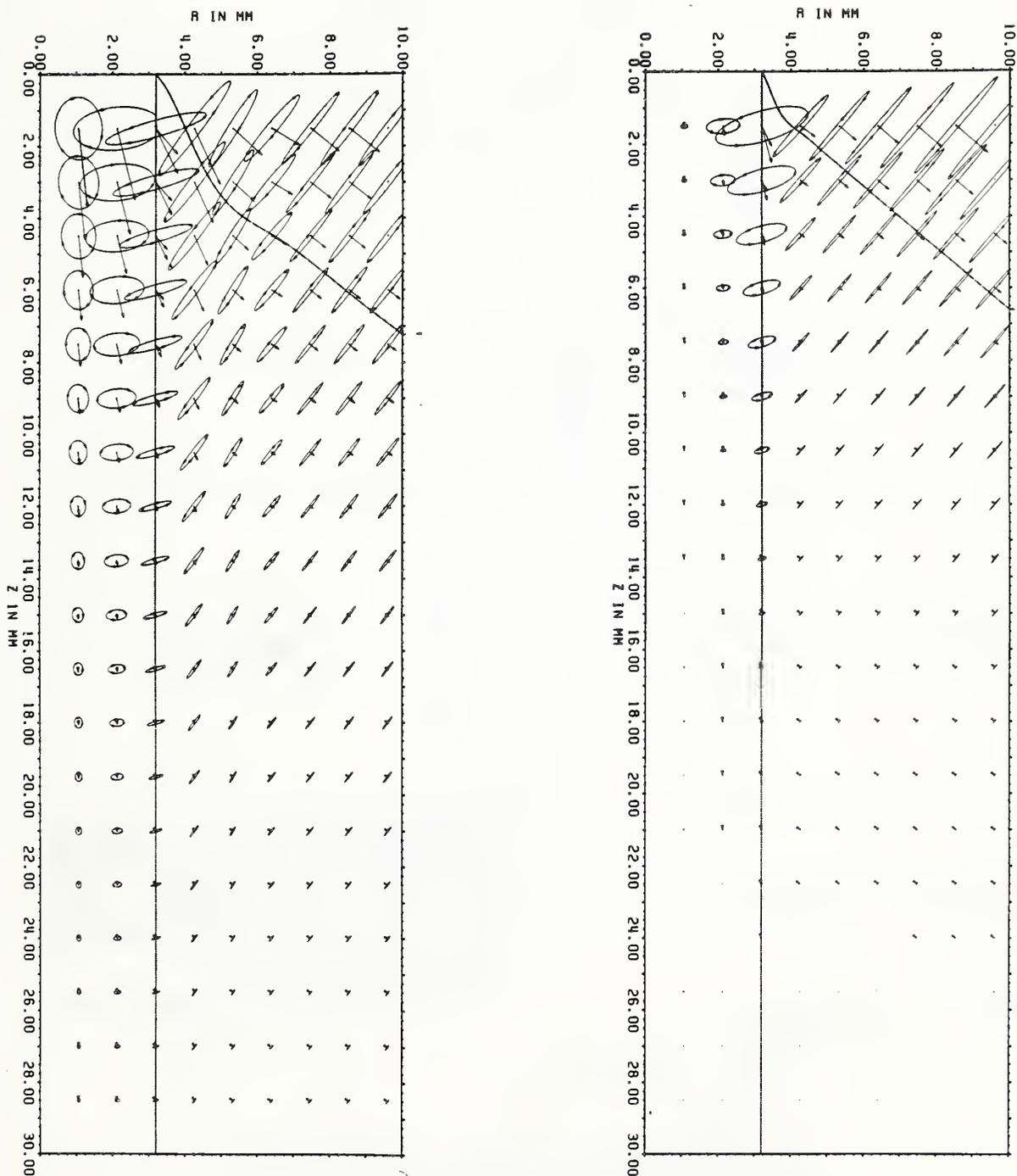

Figure 7. Predicted displacement fields for a leaky guided interface wave previously detected experimentally in Al/SiC at two selected frequencies. The radius of the SiC rod here is 3.17 mm and that of the outer aluminum is 10 mm. Since only the product $R \cdot F$ determines these curves, the same figure would hold for a $3.2 \mu\text{m}$ radius rod at gigahertz frequencies.

MODE I Al-SiC

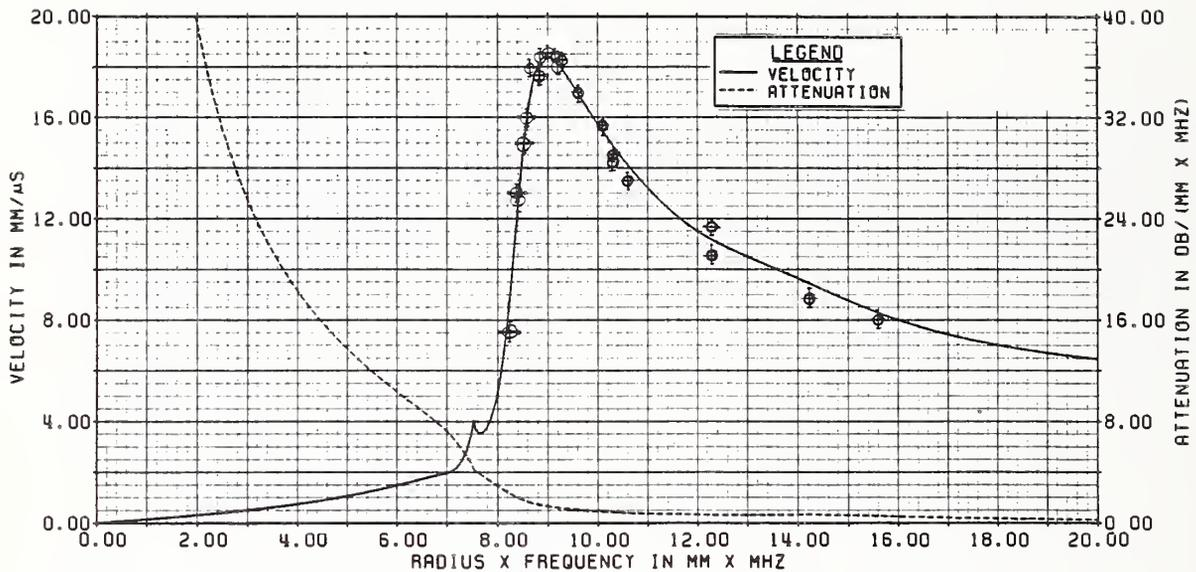

Figure 8. Calculated dispersion curve for a high phase velocity leaky mode in Al/SiC as compared with experimental measurements (shown as circles with error bars).

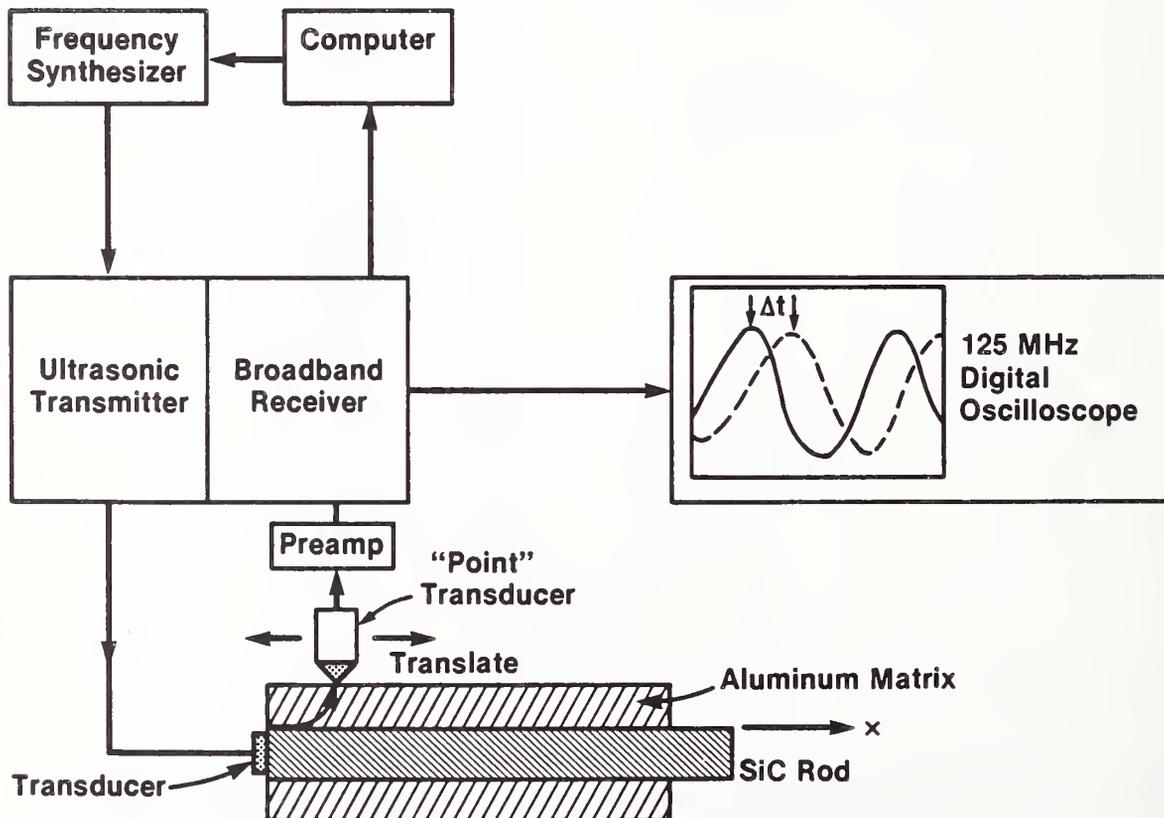

Figure 9. Schematic view of Interface Wave Acoustic Microscope.

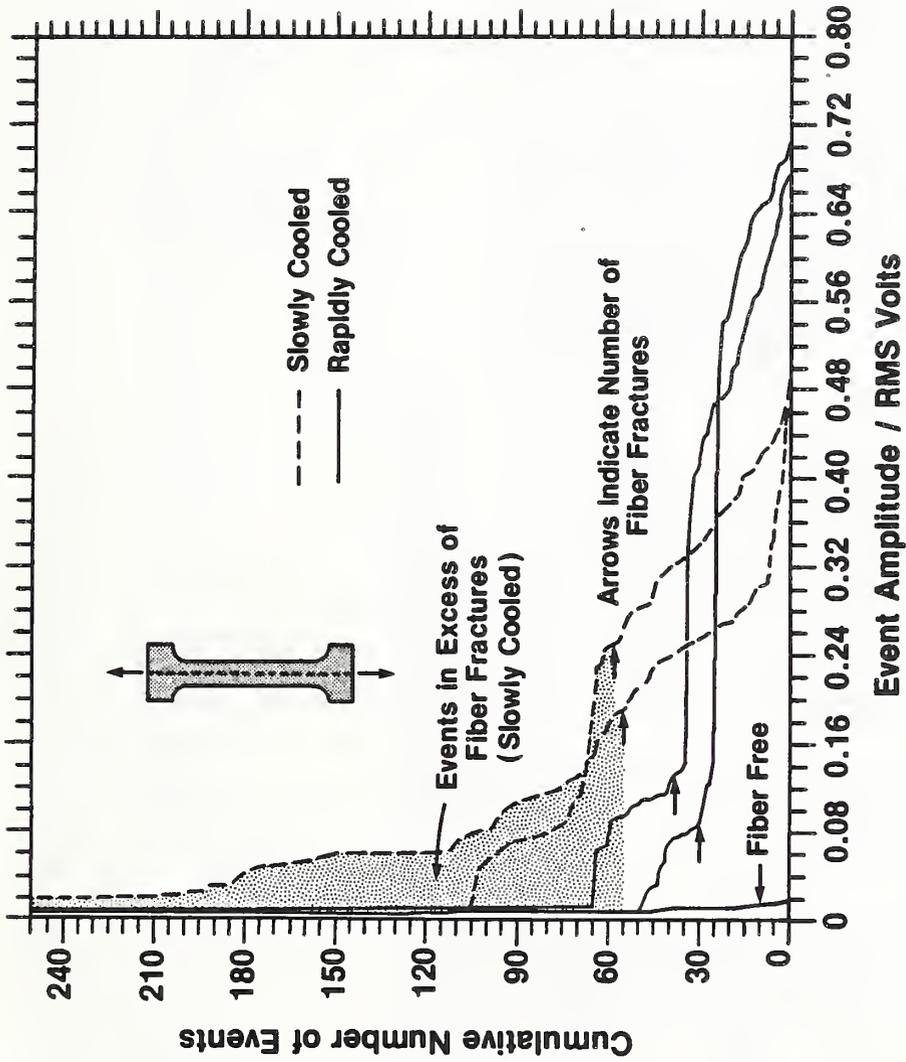

Figure 10. Cumulative amplitude of AE events in relation to metallographically observed fiber fractures for two types of processing (slow and rapid cooling).

| 4340 STEEL PROPERTIES | | | | | STEEL/TITANIUM° DUPLEX PLATE | | | | |
|--|------------------------------|---------------------|----------------------|----------|-------------------------------|-----------------------|-------------------------|-----------------|--|
| Microstructure | Density (kg/m ³) | Long Velocity (m/s) | Shear Velocity (m/s) | Case No. | Rolling Direction of Ti Plate | Predicted Wave Type | Interface Wave Velocity | | |
| | | | | | | | Measured (m/s) | Predicted (m/s) | |
| Fine Pearlite (Held at 1200F) | 7840 | 5952 | 3250 | 1A | ⊥ | Stoneley | 3217 ± 15 | 3247 | |
| | | | | 1B | ∥ | Leaky in Ti | 3217 ± 15 | 3232 | |
| Tempered Martensite (Quenched and Temp.) | 7805 | 5868 | 3170 | 2A | ⊥ | Divergent in Steel | 3216 ± 55 | 3170 | |
| | | | | 2B | ∥ | Stoneley | 3166 ± 15 | 3162 | |
| Bainite (Air cooled) | 7817 | 5869 | 3175 | 3A | ⊥ | Divergent in Steel | 3221 ± 55 | 3175 | |
| | | | | 3B | ∥ | Stoneley | 3162 ± 15 | 3166 | |
| Fine Pearlite (As Received- Hot Rolled) | 7839 | 5934 | 3235 | 4A | ⊥ | Stoneley | 3223 ± 15 | 3233 | |
| | | | | 4B | ∥ | Leaky in Ti | 3206 ± 15 | 3218 | |

*Density of Ti-6Al-4V = 4430 kg/m³,
 Longitudinal velocity of Ti-6Al-4V = 6287 m/s in both directions
 Shear velocity of Ti-6Al-4V: { Perpendicular to rolling direction (⊥) = 3287 m/s,
 Parallel to rolling direction (∥) = 3171 m/s.

Table I. Interface wave velocities for four different microstructures in 4340 steel and two different orientations of a block of rolled Ti-6Al-4V.

Table II
MEASURED FIBER AND INTERFACE STRENGTH VALUES

| | C-Enriched Fiber Surface | | Untreated Fiber | |
|--|-----------------------------|-------------------|--------------------|-------------------|
| | Rapid Cooling | Slower Cooling | Rapid Cooling | Slower Cooling |
| Fiber Tensile Strength (MPa) | 658 | 159 | 440 | < 35 |
| Interface Shear Strength (MPa) | 12 | 9.2 | 19 | < 3.0 |
| Matrix Shear Strength (MPa) | 7 | 8.0 | 8.0 | 7.5 |
| Interface Critical Stress Intensity K_{Ic} (MPa.m ^{1/2}) | 3.8 | 0.94 | 2.6 | <0.20 |
| Interface Adhesive Energy (J/m ²) | 7.8 | 0.46 | 3.5 | <0.02 |

Table II. Measured fiber and interface strength values, σ_{IC}/A_1 .

The Magnetic Materials Group is concerned with the measurement of the magnetic properties of advanced magnetic and superconducting materials. The objectives are (1) to relate the metallurgical, magnetic and electronic structure to the magnetic and superconducting properties of materials, (2) to develop new and improved magnetic measurement methods, (3) to develop magnetic reference standards, (4) to apply magnetic phenomena to the nondestructive evaluation of materials and structures, and (5) to provide expertise to industry, universities and other government agencies.

Magnetic materials are important to the commerce of the United States. For example, the sales of soft magnetic materials (primarily for information and data storage) amounts to more than 25 billion dollars per year. The sales of hard magnetic materials (primarily for motors) are more than one billion dollars per year and have been recently increasing due to the discovery of supermagnetic rare-earth alloys. Magnetic methods of nondestructive evaluation are used for quality control practically everywhere steel is used.

FY 87 Significant Accomplishments

- o A time-dependent magnetization was discovered in textured Ni-Cu compositionally-modulated alloys. The mechanism for this unexpected magnetic aftereffect, which has both scientific and technological implications, is not yet fully understood.
- o Meissner effect measurements were used to characterize the new high temperature superconductors of the type $Ba_2YCu_3O_{7-x}$ as a function of processing changes. Transition temperature, transition width, magnetic critical currents, and superconducting fraction were all measured.
- o Thin-film high T_c superconducting oxides have been prepared directly from the vapor with no subsequent thermal treatment required by a novel method of laser ablation. The superconducting transition temperatures for the ablated thin films of $La_{1.85}Sr_{0.15}CuO_{4-x}$ at 41.5K and of $Ba_2YCu_3O_{7-y}$ at 94.5 K are the same as for the bulk targets.
- o Co-sputtering was used to produce a granular-metal thin film containing an immiscible mixture of nanometer-sized particles of a magnetic oxide (Fe_3O_4) and a nonmagnetic metal (Ag) for the first time. In addition to superparamagnetic behavior, it was found that only a very small percentage of Ag was required to obtain the granular-metal morphology.
- o A temperature hysteresis in the initial magnetic susceptibility of rapidly solidified Monel, suggesting metastable magnetic equilibrium, was discovered.
- o The local topology of atoms in crystals, studied using a modified Wigner-Seitz construction, has been shown to be able to predict the correct orientations of the magnetic anisotropies in hard magnetic materials.
- o An ASTM round-robin test on standard flaws for magnetic particle NDE has been initiated.

Magnetic Properties of Materials

L. J. Swartzendruber, R. D. Shull, U. Atzmony* and L. H. Bennett

*Guest Scientist - Nuclear Research Center - Negev, Israel

Granular metals - An investigation was initiated of this class of advanced thin-film magnetic materials. In these cermet-like materials, a mutually immiscible metal and dielectric are codeposited. Granular metals have been found to possess a multitude of electronic and magnetic phenomena including ferromagnetism, superparamagnetism, spin-glass behavior, percolation effects and superconductivity. For example, a four-fold enhancement in the superconducting critical temperature of Al was reported in the granular metal Al + Al₂O₃. Co-sputtering was used to produce a granular-metal thin film containing an immiscible mixture of nanometer-sized particles of a magnetic oxide (Fe₃O₄) and a nonmagnetic metal (Ag) for the first time. In addition to superparamagnetic behavior, it was found that only a very small percentage of Ag was required to obtain the granular-metal morphology (see Figure 1).

CMA - Measurements have been made of the magnetic properties of Ni-Cu compositionally-modulated alloys (CMA) fabricated with the use of pulsed potentiostatic deposition by the Electrodeposition Group. Textured samples were produced by epitaxial deposition in each of the three principal cubic orientations. Vibrating sample magnetometry was carried out at NBS. Ferromagnetic resonance and SQUID magnetometry was performed at the Naval Research Laboratory in a cooperative research effort. A time-dependent magnetization was discovered (see Figure 2) in these textured samples. The mechanism for this unexpected magnetic aftereffect, which has both scientific and technological implications, is not yet fully understood. It is possible that the mechanism is not related to the modulation per se but is inherent in each isolated nickel layer. This possibility will be tested by increasing the Cu layer thickness in the CMA.

Temperature hysteresis - An unexpected temperature hysteresis was discovered in the initial magnetic susceptibility of rapidly solidified Monel (Ni_{0.72}Cu_{0.28}). The hysteresis is exhibited by higher susceptibility values during the cooling-down stage compared to the warming up. A transformation between the two values can be abruptly induced by an external disturbance, suggesting that the higher values represent metastable magnetic equilibrium.

Icosahedral phase - Combining magnetic susceptibility measurements and nuclear magnetic resonance, a theory of enhanced magnetism in icosahedral Al-Mn was refuted. Instead, it is likely that the low temperature magnetism often observed in these alloys is due to sample inhomogeneities. Using nuclear magnetic resonance in crystalline Al₁₂Mn, a theory of the icosahedral phase by Linus Pauling was effectively refuted.

Local topology - Using a modified Wigner-Seitz (or Voronoi) construction, we continue to study the local topology of atoms in magnetic materials in collaboration with Dr. R. E. Watson of Brookhaven National Laboratory. In addition to the relation between the occurrence of strong magnetism and "disclination" paths inferred from our computations, we have shown that the correct orientations of the magnetic anisotropies in hard magnetic materials can be derived.

High-Temperature Superconductors

L. J. Swartzendruber, R. D. Shull, U. Atzmony* and L. H. Bennett

Magnetic measurements of the new high temperature superconductors of the type $Ba_2YCu_3O_{7-x}$ were made to help determine the influence of varying process parameters on the quality of the superconducting material. The samples were prepared and processed in the Ceramics Division. As an example, a hysteresis loop made in a vibrating sample magnetometer at 38 K is shown in Figure 3. From such data, critical currents and critical fields are obtained. Using an automated ac susceptometer featuring a flow dewar to determine the relative Meissner effect, the superconductors were characterized as a function of processing changes. Transition temperature, transition width and superconducting fraction were all measured (for an example, see Figure 4). Measurements could be made from 6 to 400K.

Thin-film high T_c superconducting oxides have been prepared directly from the vapor with no subsequent thermal treatment by a novel method of laser ablation. This work was carried out in a cooperative research program with Dr. Kishin Moorjani, of the Applied Physics Laboratory of Johns Hopkins University. The superconducting transition temperatures for the ablated thin films of $La_{1.85}Sr_{0.15}CuO_{4-x}$ at 41.5K and of $Ba_2YCu_3O_{7-y}$ at 94.5 K are the same as for the bulk targets.

Magnetic NDE

L. J. Swartzendruber

A variety of magnetic methods are currently being used in nondestructive evaluation, both for detecting defects and for verifying material properties. Some of these methods, such as magnetic particle inspection, magnetic flux leakage testing, and magnetic permeability measurement, are widely used in industry, the first two for defect detection, and the latter for property determinations such as ferrite content in stainless steel welds. Magnetic property measurements (e.g., saturation magnetization, coercivity, Barkhausen noise, and initial permeability) contain a wealth of information concerning material properties that has barely begun to be exploited. One of the primary standard samples presently used in magnetic particle inspection (perhaps the most used of all nondestructive evaluation methods) has been the so-called Ketos ring. This is a circular ring made of a specific tool steel with specified dimensions and with twelve holes drilled at various depths. Based on measurements performed at NBS and elsewhere, it has recently been realized that a wide variation in properties, and hence in test results, are exhibited by these rings. As a temporary solution, a new heat treatment has been selected for these rings which appears to reduce their variability to an acceptable level. This new heat treatment is currently being incorporated into various military and industrial standards. To provide for a better standard, we have initiated and are currently coordinating an ASTM round robin test on artificial flaw standards. The round robin is designed to relate the results obtained on the flaw standards to results on the test ring and on actual parts using developed procedures. Based on the results of this round robin, and on further tests at NBS, we will appraise such flaw standards to be NBS Standard Reference Materials.

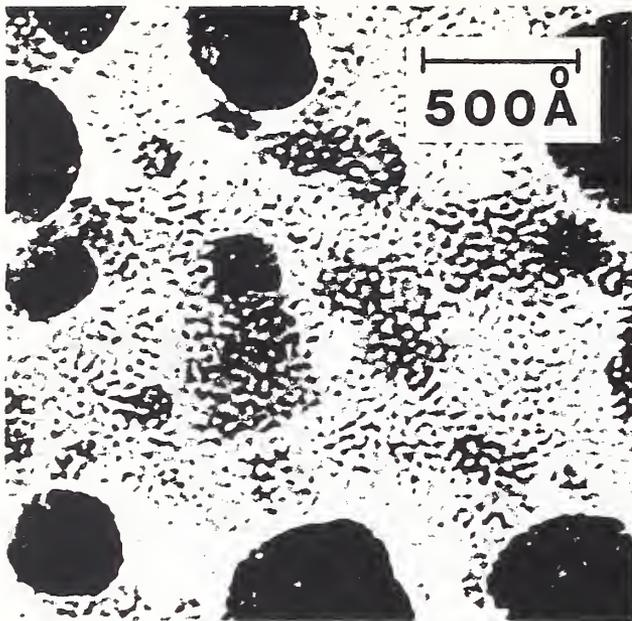

Fig. 1. Granular metal (iron oxide + Ag). TEM picture shows conglomerated iron-oxide and silver imbedded in a thin-film matrix of interconnected nanometer-sized Ag (dark) and Fe_3O_4 (light) granules.

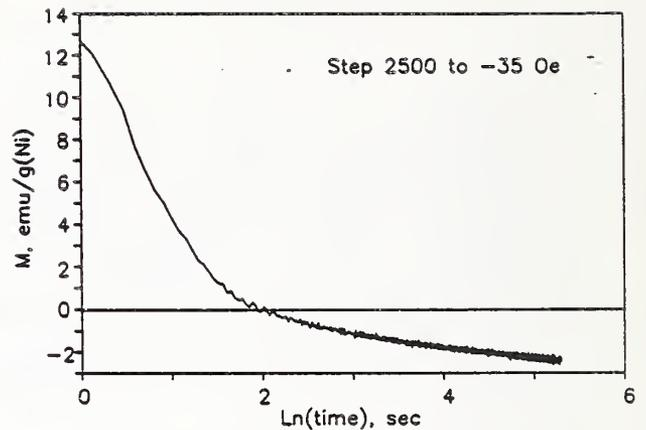

Fig. 2. Magnetic aftereffect in a [111]-textured Cu/Ni compositionally-modulated alloy. Magnetization vs. natural logarithm of the time after reducing the applied field.

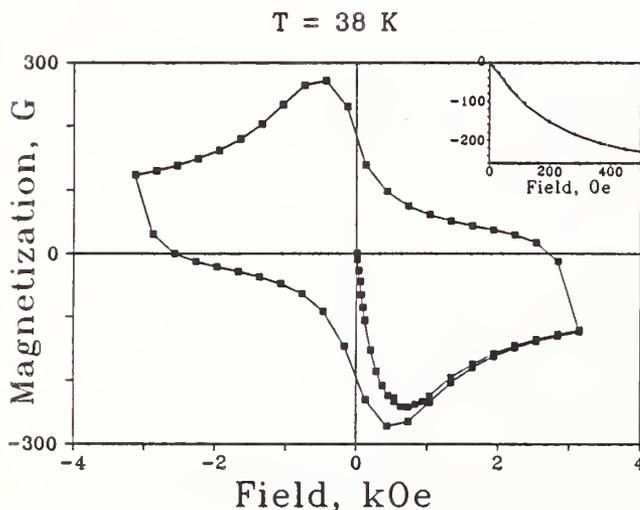

Fig. 3. Hysteresis loop for a sample of $Ba_2YCu_3O_{7-x}$ measured in the vibrating sample magnetometer at 38 K. The data points are shown as squares. The inset shows the virgin curve. From such data, critical currents and critical fields are obtained and help determine the influence of varying process parameters on the quality of the superconducting material.

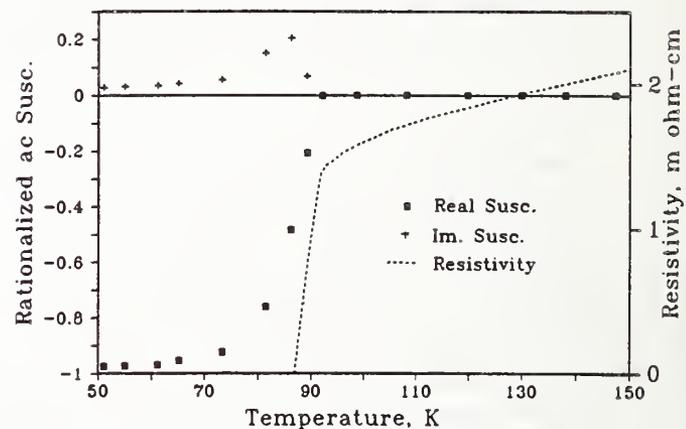

Fig. 4. Measured ac magnetic susceptibility and electrical resistivity for $Ba_2YCu_3O_{7-x}$. The temperature where $\approx \frac{1}{2}$ the material is superconducting (as determined from the real part of the susceptibility), the zero in resistivity, and the peak in the imaginary part of the susceptibility, all occur at approximately the same temperature.

PUBLICATIONS

Metallurgical Processing Group

Bendersky, L. A.; Biancaniello, F. S.; TEM observation of icosahedral, new crystalline and glassy phases in rapidly quenched Cd-Cu alloys. Scripta Met. 21; 531; 1987.

Bendersky, L. A.; Biancaniello, F. S.; Boettinger, W. J.; Perepezko, J. H.; Microstructural characterization of rapidly solidified Nb-Si alloys. J. Mat. Sci. and Eng. 89; 151; 1987.

Bendersky, L. A.; Biancaniello, F. S.; Boettinger, W. J.; Perepezko, J. H.; Microstructure of rapidly solidified Nb-Si alloys. Mats. Sci. and Eng. 89; 151; 1987.

Bendersky, L. A.; Biancaniello, F. S.; Schaefer, R. J.; Phase separation in $Al_{70}Si_{17}Fe_{13}$ alloy. J. Mat. Res.; in press.

Bendersky, L. A.; Graves, J. A.; Biancaniello, F. S.; Perepezko, J. H.; Boettinger, W. J.; Pathways for microstructural development in TiAl. Proceedings of Sixth International Conference on Rapidly Quenched Metals; Montreal, Canada; J. Mat. Sci. and Eng.; 1987; in press.

Bendersky, L. A.; Kaufman, M. J.; Boettinger, W. J.; Biancaniello, F. S.; Solidification of an 'amorphous' phase in rapidly solidified Al-Fe-Si alloys. Proceedings of Sixth International Conference on Rapidly Quenched Metals; Montreal, Canada; J. Mat. Sci. and Eng.; 1987; in press.

Bendersky, L. A.; Ridder, S. D.; On the glass formation in system forming icosahedral quasicrystals. Mat. Res. Soc. Symp. Proc.; Vol. 80; 349; 1987.

Bendersky, L. A.; Schaefer, R. J.; Formation of quasicrystals. Physical 140A; 298; 1986.

Blendell, J. E.; Handwerker, C. A.; Shen, C.; Dang, N.-D.; Diffusion-induced grain boundary migration in ceramics. Interfaces in ceramics; J. Pask, ed.; Materials Science Research; Plenum Press; 1987; in press.

Boettinger, W. J.; Microstructural variations in rapidly solidified alloys. Proceedings of Sixth International Conference on Rapidly Quenched Metals; Montreal, Canada; J. Mat. Sci. and Eng.; 1987; in press.

Boettinger, W. J.; Bendersky, L. A.; Biancaniello, F. S.; Cahn, J. W.; Rapid solidification and ordering of B₂ and L₂₁ phases in the NiAl-NiTi system. Proceedings of Sixth International Conference on Rapidly Quenched Metals; Montreal, Canada; J. Mat. Sci. and Eng.; 1987; in press.

Boettinger, W. J.; Bendersky, L. A.; Coriell, S. R.; Schaefer, R. J.; Biancaniello, F. S.; Microsegregation in rapidly solidified Ag-15 wt% Cu alloys. J. Cryst. Growth 80; 17; 1987.

- Boettinger, W. J.; Bendersky, L. A.; Schaefer, R. J.; Biancaniello, F. S.; On the formation of dispersoids during rapid solidification of an Al-Fe alloy. *Met. Trans. A*; 1987; in press.
- Boettinger, W. J.; Coriell, S. R.; Microstructure formation in rapidly solidified alloys. *Proceedings of NATO Advanced Research Workshop on Rapid Solidification Technologies*; P. R. Sahm, H. Jones, C. M. Adam, eds.; NATO ASI Series E-N0114; Martinus-Nijhof; Dordrecht; p. 81; 1986.
- Boettinger, W. J.; Voorhees, P. W.; Dobbryn, R. C.; Burdette, H. E.; A study of the coarsening of liquid-solid mixtures using synchrotron radiation microradiography. *Met. Trans. 18A*; 487; 1987.
- Coriell, S. R.; McFadden, G. B.; Voorhees, P. W.; Stability of a planar interface during solidification of a multicomponent system. *J. Cryst. Growth 82*; 295; 1987.
- Hackney, S. A.; Biancaniello, F. S.; Directional invariance of grain boundary migration in the Pb-Sn cellular transformation and the Turnbull hysteresis. *Scripta Met. 20*; 1417; 1986.
- Hackney, S. A.; Biancaniello, F. S.; Experimental indications of a low undercooling instability in the cellular mechanism of discontinuous precipitation. *Scripta Met. 21*; 371; 1987.
- Handwerker, C. A.; Diffusion induced grain boundary migration in thin films; in *Diffusion in Thin Films*. Gupta, D.; Ho, P., eds. Noyes Publications; 1987; in press.
- Handwerker, C. A.; Morris, P. A.; Coble, R. L.; Effects of chemical inhomogeneities on grain growth and microstructure in Al_2O_3 . *J. Amer. Cer. Soc.*; 1987; in press.
- Handwerker, C. A.; Vaudin, M. D.; Blendell, J. E.; Equilibrium crystal shapes and surface phase diagrams at surfaces in ceramics. *Proceedings of Conference on Interface Science and Engineering*; Lake Placid, NY. *J. de Physique Colloque*; 1987; in press.
- Johnson, W. C.; Voorhees, P. W.; Elastic interaction and stability of misfitting cuboidal inhomogeneities. *J. Appl. Phys. 61*; 1610; 1987.
- Johnson, W. C.; Voorhees, P. W.; Phase equilibrium in two phase coherent solids. *Met. Trans. 18A*; 1213; 1987.
- Kaysser, W. A.; Sprissler, M.; Handwerker, C. A.; Blendell, J. E.; The effect of a liquid phase on the morphology of grain growth in alumina. *J. Amer. Cer. Soc. 70*[5]; 339; 1987.
- Laria, V. J.; Johnson, W. C.; Voorhees, P. W.; Growth of a misfitting coherent precipitate. *J. Mat. Res.*; 1987; in press.
- McAlister, A. J.; Bendersky, L. A.; Schaefer, R. J.; Biancaniello, F. S.; Transformation of the icosahedral phase in rapidly quenched Al-rich Al-Mn alloys. *Scripta Met. 21*; 103; 1987.

- McFadden, G. B.; Coriell, S. R.; Thermosolutal convection during directional solidification. II. flow transitions. *Phys. Fluids* 30 (3); 659; 1987.
- McFadden, G. B.; Voorhees, P. W.; Boisvert, R. F.; Meiron, D. I.; A boundary integral method for the simulation of two-dimensional particle coarsening. *J. Sci. Computing* 1; 117; 1986.
- Perepezko, J. H.; Boettinger, W. J. Kinetics of resolidification. Surface alloying by ion electron and laser beams; L. E. Rehm, S. T. Picraux, K. H. Wiedersich, eds.; ASM; Metals Park, OH; 51; 1987.
- Ridder, S. D.; Biancaniello, F. S.; Process control during high pressure atomization. Proceedings of Sixth International Conference on Rapidly Quenched Metals; Montreal, Canada; *J. Mat. Sci. and Eng.*; 1987; in press.
- Rottman, C.; Theory of phase transitions at internal interfaces. Proceedings of Conference on Interface Science and Engineering; Lake Placid, NY. *J. de Physique Colloque*; 1987; in press.
- Rottman, C.; Thermal fluctuations in low-angle grain boundaries, *Acta Met.*; 1986; in press.
- Schaefer, R. J.; The metallurgy of quasicrystals. *Scripta Met.* 20; 1187; 1986.
- Schaefer, R. J.; Biancaniello, F. S.; Gahn, J. W.; Formation and stability range of G phase in the Al-Mn System. *Scripta Met.* 20; 1439; 1986.
- Schaefer, R. J.; Bendersky, L.; Formation of quasicrystals in rapidly solidified Al alloys. *Mat. Res. Soc. Symp. Proc.*; Vol. 58; 217; 1986.
- Schaefer, R. J.; Bendersky, L.; Biancaniello, F. S.; Nucleation and growth of aperiodic crystals in aluminum alloys. Proceedings of International Workshop on Aperiodic Crystals. *Journal de Physique, Coll. C3, Tome 47*; 311; 1986.
- Schaefer, R. J.; Bendersky, L. A.; Shechtman, D.; Boettinger, W. J.; Biancaniello, F. S.; Icosahedral and decagonal phase formation in Al-Mn alloys. *Met. Trans.* 17A; 2117; 1986.
- Schaefer, R. J.; Bendersky, L. A.; Shechtman, D.; Boettinger, W. J.; Biancaniello, F. S.; Metallurgy of phase relationships of icosahedral Al-Mn. *Met. Trans.* 17A; 2117; 1986.
- Schaefer, R. J.; Bendersky, L. A.; Shechtman, D.; Boettinger, W. J.; Biancaniello, F. S.; Icosahedral and decagonal phase formation in Al-Mn alloys. *Met. Trans.* A; 1986; in press.
- Vaudin, M. D.; Handwerker, C. A.; Blendell, J. E.; Electron microscopy studies of diffusion induced grain boundary migration in ceramics. Proceedings of Conference on Interface Science and Engineering; Lake Placid, NY. *J. de Physique Colloque*; 1987; in press.

Voorhees, P. W.; McFadden, G. B.; Boisvert, R. F.; Meiron, D. I.; Numerical simulation of morphological development during late stage phase separation in two dimensions. Acta Met.; 1987; in press.

Voorhees, P. W.; Schaefer, R. J.; In situ observation of particle motion and diffusional interactions during coarsening. Acta Met. 35; 327; 1987.

Corrosion and Wear Group

Anderson, D. B.; The NACE-NBS Corrosion Data Program. Proc. 1987 Tri-Services Corrosion Conference.

Bertocci, U.; Leigh, S.; Van Orden, A.C.; Yang, G.; Statistics of pit initiation: analysis of current transients during passive film breakdown. Mat. Res. Soc. Symp. Proc.; Vol. 84; 1987 Materials Research Society.

Bertocci, U.; Pugh, E. N.; Modelling of the potential at the tip of a transgranular stress-corrosion crack in the alpha-brass-ammonia system. Conf. Proc. National Physical Lab, Teddington, Middlesex, UK; Oct. 1-3, 1984; Corrosion Chemistry Within Pits, Crevices and Cracks; p 187-201; Edited by A. Turnbull.

Bertocci, U.; Statistics of localized breakdown noise. Proc. of NACE International Conf. on Localized Corrosion 1987.

Bertocci, U.; Pugh, E. N.; Modelling of electrochemical processes during transgranular stress corrosion cracking of copper-base alloys. Proc. International Congress on Metallic Corrosion; in press.

Blau, P. J.; A model for run-in and other transitions in sliding friction. ASME Journal of Tribology; Vol. 109 (1987); p 537-544.

Blau, P. J.; Whinton, E. P.; Abrasive break-in modeling of steel, aluminum, and PMMA. Submitted to WEAR 1987.

Blau, P. J.; Doyle, E. D.; Metallographic evidence for the nucleation of subsurface microcracks during unlubricated sliding of metals. WEAR 1987; Vol. 117; p 381-387.

Cassagne, T. B.; Kruger, J.; Pugh, E. N.; The role of the oxide film in the transgranular stress corrosion cracking of copper. ASTM Proc. on Environmentally-Assisted Cracking: Science and Engineering; in press.

Craig, B.; Jones, R. H.; Kamdar, M. H.; Ricker, R. E.; Environmentally induced cracking. Metals Handbook; Vol.13; Corrosion; ASM International; Metals Park, OH; 1987; in press.

Czichos, H.; Ruff, A. W.; Results of the Versailles Advanced Materials and Standards (VAMAS) interlaboratory study on west test materials. VAMAS Bulletin, 1987; in press.

Early, J. G.; Smith, J. H.; Weldability of a leaded carbon steel. NBSIR-87-3598; June 1987.

Escalante, E., Whintont, E.; Qiu, F.; Measuring the rate of corrosion of reinforcing steel in concrete. Federal Highway Administration; NBSIR 86-3456; October 1986.

Escalante, E.; The effect of soil resistivity and soil temperature on the corrosion of galvanically coupled metals. Galvanic Corrosion of Metals; ASTM STP 978; July 1987.

Escalante, E.; Corrosion testing in soil. Metals Handbook, Ninth Edition; Vol. 13; September 1987.

Escalante, E.; Concepts of underground corrosion. The Effects of Soil Characteristics on Corrosion; ASTM STP; in press.

Fraker, Anna C.; Corrosion of metallic implants for prosthetic devices. American Soc. for Metals Handbook; Corrosion; Vol. 13; 1987.

Freeman, R. W.; Salkind, A. J.; Viswanathan, V.; Hall, D. E.; Lipka, S. M.; Impregnation and performance of fiber mat nickel electrodes. Electrochemical Society Extended Abstracts; Vol 87-1; 1987.

Hall, D. E.; Electrodeposited metal coatings on graphite fibers. Proc. Symp. Electrodeposition Theory, Technology and Practice; D. R. Turner and L. T. Romankiw, Editors; The Electrochemical Society; 1986.

Interrante, C.; Escalante, E.; Fraker, A.; Kaufman, M.; Liggett, W.; Shull, R.; Evaluation and compilation of DOE waste package test data. Biannual Report Covering the Period December 1985 to July 1986. NUREG/CR-4735; Vol. 1; March 1987.

Interrante, C.; Escalante, E.; Fraker, A.; Harrison, S.; Ricker, R. E.; Ruspi, J.; Shull, R.; Evaluation and compilation of DOE waste package test data. Biannual Report Covering the Period August 1986 to January 1987. NUREG/CR-4735; Vol. 2; September 1987.

Ives, L. K.; Peterson, M. B.; Whintont, E. P.; Mechanisms of galling and abrasive wear. Proc. of the Fossil Energy Materials Conference; Oak Ridge, TN; May 1987; in press.

Ives, L. K.; Peterson, M.; Ruff, A. W.; Harris, J. S.; Boyer, P.A.; Wear due to printing inks. NBSIR 87-3574; Report to US Bureau of Printing and Engraving; 1987.

Lipka, S. M.; Hall, D. E.; Porous nonsintered nickel coated graphite fiber electrode structures. Electrochemical Society Extended Abstracts; Vol. 87-1; 1987.

Peterson, M. B.; Ives, L. K.; Bhansali, K. J.; A literature review of the galling process. Metal Transfer and Galling in Metallic Systems; AIME; New York, NY; 1987; in press.

- Peterson, M. B.; Advances in tribomaterials 1937-1987-2002. Proc. of International Conference on Lubrication-Lubrication 50 Years On; I.Mech.E.; London, UK; 1987.
- Polvani, R. S.; Ruff, A. W.; Robbins, J. C.; Dynamic microindentation of RDX: effect of rate on plasticity and fracture. NBS Report to Office of Naval Research; 1987.
- Polvani, R. S.; Ruff, A. W.; Whitenton, E. P.; A dynamic micro-indentation apparatus for materials characterization. Journal of Testing and Evaluation; ASTM; in press.
- Ricker, R. E.; Contributions to the book: Metals Handbook Ninth Edition; Vol. 12; Fractography. Publ. ASM International; Metals Park, OH; 1987.
- Ricker, R. E.; The influence of environment on the fatigue properties of aluminum alloys. Modeling Environmental Effects on Crack Growth Processes; R. H. Jones and W. W. Gerberich, eds.; American Institute of Mining, Metallurgical and Petroleum Engineers; New York, NY; 1986; p 371-380.
- Ricker, R. E.; Duquette, D. J.; The role of hydrogen in corrosion fatigue of high purity Al-Zn-Mg exposed to water vapor. Metall. Trans. A; submitted 1987.
- Ruff, A. W.; Myshkin, N. K.; Lubricated wear behavior and surface-active media effects of composition-modulated nickel-copper coatings on steel. Journal of Tribology; submitted 1987.
- Ruff, A. W.; Standard practice for pin-on-disk wear testing of materials. ASTM Committee G-2; Committee Draft submitted 1987.
- Shen, M. C.; Cheng, H.; Peterson, M. B.; A computer analysis of lubrication of dynamically loaded journal bearings including the effects of asperity contacts. Transactions ASLE Meeting; Anaheim, CA; May 1987.
- Sung, Pei; Fraker, Anna C.; Corrosion, repassivation and corrosion fatigue behavior of the surgical implant alloy, Co-Cr-Mo. Environmental Degradation of Engineering Materials; The Pennsylvania State University; Vol. III; p 471-480; 1987.
- Sung, Pei; Fraker, Anna C.; Corrosion and degradation of a polyurethane/Co-Ni-Cr-Mo pacemaker lead. Journal Applied Biomaterials; December 1987; in press.
- Swanson, P. A.; Ives, L. K.; Whitenton, E. P.; Peterson, M. B.; A study of the galling of two steels using two test methods. Wear of Materials - 1987; K. C. Ludema, ed.; ASME; New York, NY; 1987; p 49-58.
- Smith, J. H.; Evaluation of cracking in aluminum cylinders. NBSIR-86-3492; March 1987.

Smith, J. H. Evaluation of bolts. Special report to U.S. House of Representatives Committee on Energy and Commerce; December 22, 1986.

Vasudevan, A. K.; Liu, J.; Ricker, R. E.; Mechanism of stress corrosion crack growth resistance of Al-Li-Cu alloys: role of grain boundary precipitates. Environmental Degradation of Engineering Materials III; M. R. Louthan, Jr., R. P. McNitt, and R. D. Sisson, Jr., eds.; The Pennsylvania State University, University Park, PA; 1987; p 321.

Verink, E. D.; Kolts, J.; Rumble, J.; Ugiansky, G. M.; Corrosion data program workshop summary. Materials Performance; Vol. 26; No. 4; 1987.

Whitenton, E. P.; Peterson, M. B.; Ives, L. K.; Method for quantitative measurement of galling damage. Metal Transfer and Galling in Metallic Systems; AIME; New York, NY; 1987; in press.

Metallurgical Structure Group

Bennett, L. H.; McAlister, A. J.; Vegard's law. Encycl. of Mat. Sci and Eng.; Meyer, M. B.; Editor; Pergamon Press, N. Y.; 1986; 5241.

Burton, B. P.; Davidson, P. M.; Short-range order and frustration in omphacite. Physics and Chemistry of Minerals; in press.

Burton, B. P.; Davidson, P. M.; Order-disorder in omphacite pyroxenes: a model for coupled substitution in the point approximation. American Mineralogist; 72; 337; 1987.

Burton B. P.; Reply to discussion of the above publication by R. E. Cohen; American Mineralogist; 1987; in press.

Burton, B. P.; Davidson, P. M.; Multicritical phase relations in minerals. Advances in Physical Geochemistry. S. Ghose, Ed.; Springer-Verlag; in press.

Capobianco, C. B.; Burton, B. P.; Davidson, P. M.; Navrotsky, A.; Structural and calorimetric studies of order-disorder in $\text{CdMg}(\text{CO}_3)_2$. Journal of Solid State Chemistry; in press.

Clark, J. B.; Nayeb-Hashemi, A. A.; The Mg-Sc (magnesium-scandium) system. Bull. Alloy Phase Diagrams 7(6); 514; 1986.

Clark, J. B.; Nayeb-Hashemi, A. A.; The Be-Mg (beryllium-magnesium) system. Bull Alloy Phase Diagrams 8(1); 57; 1987.

Clark, J. B.; Nayeb-Hashemi, A. A.; The Ca-Mg (calcium-magnesium) system. Bull. Alloy Phase Diagram 8(1); 58; 1987.

Clark, J. B.; Nayeb-Hashemi, A. A.; The Mg-Po (magnesium-polonium) system. Bull. Alloy Phase Diagrams 8(2); 116; 1987.

Clark, J. B.; Nayeb-Hashemi, A. A.; The Mg-Rh (magnesium-rhodium)

- system. Bull. Alloy Phase Diagrams 8(2); 117; 1987.
- Clark, J. B.; Nayeb-Hashemi, A. A.; The Mg-Co (magnesium-cobalt) system. Bull. Alloy Phase Diagrams 8(4); 352; 1987.
- Clark, J. B.; Nayeb-Hashemi, A. A.; The Ce-Mg (cerium-magnesium) system. Bull. Alloy Phase Diagrams; in press.
- Clark, J. B.; Nayeb-Hashemi, A. A.; The La-Mg (lanthanum-magnesium) system. Bull. Alloy Phase Diagrams; in press.
- Clark, J. B.; Nayeb-Hashemi, A. A.; The Nd-Mg (neodymium-magnesium) system. Bull. Alloy Phase Diagrams; in press.
- Kikuchi, R.; Burton, B. P.; Calculation of some oxides using cluster variation method. Physical B and C; in press.
- McAlister, A. J.; The Al-Pd (aluminum-palladium) system. Bull. Alloy Phase Diagrams 7(4); 368; 1986.
- McAlister, A. J.; Bendersky, L. A.; Schaefer, R. J.; Biancanello, F. S.; Transformation of the icosahedral phase in rapidly quenched Al-rich Al-Mn alloys. Scripta Met; 21; 103; 1987.
- McAlister, A. J.; Murray, J. L.; Schaefer, R. J.; Bendersky, L. A.; Biancanello, F. S.; Moffat, D. L.; Stable and metastable equilibria in the Al-Mn system. Met. Trans; 18A; 385; 1987.
- McAlister, A. J.; The Al-Tl (aluminum-tellurium) system. Bull. Alloy Phase Diagrams; in press.
- McAlister, A. J.; The Ag-Al (silver-aluminum) system. Bull. Alloy Phase Diagrams; in press.
- McAlister, A. J.; The Al-Mn (aluminum-magnesium) system. Bull. Alloy Phase Diagrams; in press.
- Yoon, D. N.; Shapiro, A. J.; Investigation of grain boundary migration in ternary Mo-Ni alloys. 1987; submitted for publication.

Electrodeposition Group

- Beauchamp, C. R.; Mathematical modeling of the deposition of alloys on moving fibers. Proc. 1987 AESF; Chicago, IL; July 1987.
- Goldman, A. I.; Long, G. G.; Bennett, L. H.; Lashmore, D. S.; Kuriyama, M.; Observations of two structurally distinct states in glassy Ni-P using EXAFS; submitted J. Electrochem. Soc.; June 1987.
- Johnson, C. E.; Kelley, D. R.; Mullen, J. L.; Lashmore, D. C.; Chromium: a wear resistant coating in the printing industry. Proc. of 1987 AESF International Chromium Colloquium; San Diego, CA; in press.

Johnson, C. E.; Kelley, D. R.; Mullen, J. L.; Lashmore, D. C.;
Electrodeposition of wear resistant coatings. NBSIR; in press.

Lashmore, D. S.; Dariel, M. P.; Electrodeposited Cu-Ni textured
superlattices. J. of the Electrochem. Soc.; in press.

Stafford, G. R.; Turner, C.; The electrodeposition of aluminum from
molten salts. Proc. of 1987 AESF; Chicago, IL; July 1987.

Stafford, G. R.; The electrogenerative partial oxidation of propylene.
Electrochimica Acta, 32; 1137; 1987.

Nondestructive Characterization Group

Blendell, J. E.; Chiang, C. K.; Freiman, S. W.; Fuller, Jr., E. R.;
Drescher-Krasicka, E.; Johnson, W. L.; Ledbetter, H. M.; Bennett, L. H.;
Swartzendruber, L. J., Marinenko, R. B.; Myklebust, R. L.; Bright, D. S.;
Newbury, D. E.; Processing-property relations for Ba_2YCuO_{7-x} high T_c
superconductors. Advanced Ceramic Materials, 2, No.3B; 512-529; July
1987.

Blendell, J. E.; Chiang, C. K.; Freiman, S. W.; Fuller, Jr., E. R.;
Drescher-Krasicka, E.; Johnson, W. L.; Ledbetter, H. M.; Bennett, L. H.;
Swartzendruber, L. J., Marinenko, R. B.; Myklebust, R. L.; Bright, D. S.;
Newbury, D. E.; The relationship of electrical, magnetic, and mechanical
properties to processing in high T_c superconductors. American Chemical
Society Symposium Series, High T_c Superconductors; in press.

Clough, R. B.; Biancaniello, F. S.; Wadley, H. N. G.; Measurement of
fiber fracture and fiber-matrix interface shear strengths in metal matrix
composites. Proc. of Conf. on Nondestructive Testing and Evaluation of
Advanced Materials and Composites; H. Mindlin et al. ed., Battelle Mem.
Inst., Columbus, OH; 1987.

Clough, R. B.; Wadley, H. N. G.; Biancaniello, F. S.; Fracture
mechanisms in single crystal composites. J. Acoustic Emission, Vol J;
569; 1986.

Clough, R. B.; The energetics of AE source characterization. Materials
Evaluation, Vol. 45; 556; 1987.

Clough, R. B.; Wadley, H. N. G.; Mehrabian, R.; Acoustic emission
studies of electron beam surface modification of aluminum. Met. Trans B;
1987; in press.

Kahn, A. H.; Gefen, Y.; Mester, M. L.; Wadley, H. N. G.; Eddy current
measurement of density during hot isostatic pressing. Review of Progress
in Quantitative NDE; Vol 7; D.O. Thompson and D.E. Chimenti, eds.; in
press.

Kahn, A. H.; Mester, M. L.; An eddy current system for the measurement
of aluminum rod during extrusion processing. Review of Progress in
Quantitative NDE; Williamsburg, VA.; June 1987.

- Linzer, M.; Sato, T.; Ikeda, O.; Hatsuzawa, T.; Real-time evaluation of wear particles using electromagnetic forced rotation and laser scattering. *Wear* 115; 273-284; 1987.
- Norton, S. J.; Linzer, M.; Backprojection reconstruction of random source distributions. *J. Acoust. Soc. Amer.* 81; 977-985; 1987.
- Norton, S. J.; Three-dimensional seismic inversion of velocity and density-dependent reflectivity. *Geoph. J. Roy. Astr. Soc.* 88; 393-415; 1987.
- Norton, S. J.; Fast magnetic resonance imaging with simultaneously oscillating and rotating field gradients. *IEEE Trans. Med. Imaging MI-6*; 21-31; 1987.
- Norton, S. J.; Computing ray trajectories between two points: a solution to the ray linking problem. *J. Opt. Soc. Am.*; in press.
- Norton, S. J.; Mossbauer Imaging. *NBS J. Research*; in press.
- Norton, S. J.; Mossbauer imaging. *Nature*; in press.
- Norton, S. J.; Iterative seismic inversion. *Geophys. J. Roy. Astr. Soc.*; in press.
- Norton, S. J.; Tomographic reconstruction of two-dimensional vector fields: application to flow imaging. *J. Acoust. Soc. Amer.*; in press.
- Simmons, J. A.; Turner, C. D.; Wadley, H. N. G.; Vector calibration of ultrasonic and acoustic emission transducers. *J. Acoust. Soc. Amer.*; in press.
- Wadley, H. N. G.; Simmons, J. A.; Microscopic origins of acoustic emission. *NDT Handbook, Vol. 5*; P.M. McIntyre, ed.; ASNT Press, Section 3; in press.
- Wadley, H. N. G.; Simmons, J. A.; Drescher-Krasicka, E.; Rosen, M.; Clough, R. B.; Hsieh, T.; Hirschman, K.; Biancanello, F. S.; Composite materials interface characterization. *NBS Internal Report*, in press.
- Wadley, H. N. G.; Rogers, C. D.; Internal discontinuity sensor needs for steel: Workshop proceedings; in press.
- Wadley, H. N. G.; Interfaces: the next NDE challenge. *Review of Progress in QNDE, Vol. 7*; D. O. Thompson and D. E. Chimenti, eds.; in press.
- Wadley, H. N. G.; Cook, J. R.; Ellerbrock, D. F.; Dishun, T. R.; Boyd, D. M.; Hot charging and direct rolling of continuous cast steel: in-process characterization and control. *Proc. of Iron Making and Steel Making Conference of the Iron and Steel Society of the AIME, March 29-April 1, 1987; Pittsburgh, PA.*

Wadley, H. N. G.; Rath, B. B.; Wolf; S. M.; Parrish, P. A.; eds.; Proceedings of conference on intelligent processing of materials and advanced sensors. 1987; in press.

Wadley, H. N. G.; Alers, G. A.; Noncontact ultrasonics applied to sensor needs for hot metal processing in the steel industry. Proc. of Conf. on Intelligent Processing of Materials and Advanced Sensors. H. N. G. Wadley, B. B. Rath, S. M. Wolf, and P. A. Parrish, eds.; 1987; in press.

Wadley, H. N. G.; Rosen, M.; Elkind B. J.; Ultrasonic sensor for controlling surface modification. Proc. of Conf. on Intelligent Processing of Materials and Advanced Sensors; H. N. G. Wadley, B. B. Rath, S. M. Wolf, and P. A. Parrish, eds.; 1987; in press.

Wadley, H. N. G.; Alers, G. A.; A pulsed laser/electromagnetic acoustic transducer approach to ultrasonic sensor needs for steel processing. Review of Progress in Quantitative NDE; 6A; 627; D. O. Thompson and D. E. Chimenti, eds.; Plenum Press; New York; 1987.

Wadley, H. N. G.; Nature and characteristics of sensors for intelligent processing of materials. J. of Metals; 30(10); 49-53; October 1986; and in Proc. of Conf. on Intelligent Processing of Materials and Advanced Sensors; H. N. G. Wadley, B. B. Rath, S. M. Wolf and P. A. Parrish, eds.; 1987; in press.

Magnetic Materials Group

Atzmony, U.; Swartzendruber, L. J.; Bennett, L. H.; Dariel, M. P.; Lashmore, D. S.; Rubinstein, M.; Lubitz, P.; Magnetization and magnetic aftereffect in textured Ni/Cu compositionally-modulated alloys. J. Mag. Magn. Matls.; in press.

Atzmony, U.; Norton, S. J.; Swartzendruber, L. J. and Bennett, L. H.; Mossbauer imaging: Experimental result. Nature; in press.

Bennett, L. H.; Long, G. G.; Kuriyama, M. and Goldman, A. I.; Local atomic structure in transition metal/metalloid glasses: Ni-P. Structure and Bonding in Noncrystalline Solids; G. E. Walrafen and A. K. Revesz (Plenum Publishing Corporation, New York, 1986) p. 385.

Bennett, L. H.; Kuriyama, M.; Long, G. G.; Melamud, M.; Watson, R. E. and Weinert, M.; Local atomic environments in periodic and aperiodic Al-Mn alloys. Phys. Rev. B 34, 8270 (1986).

Bennett, L. H.; Lashmore, D. S.; Dariel, M. P.; Kaufman, M. J.; Rubinstein, M.; Lubitz, P.; Zadok, O. and Yahalom, J.; Magnetic properties of electrodeposited copper-nickel composition modulated alloys. J. Mag. Magn. Matls. 67, 239 (1987).

Bennett, L. H.; Cahn, J. W.; Schaefer, R. J.; Rubinstein, M. and Stauss, G. H.; Icosahedral symmetry vs. local icosahedral symmetry in Al-Mn alloys from NMR. Nature 326, 372 (1987).

- Bennett, L. H. and Watson, R. E.; Symmetry and supersymmetry in crystals. *Phys. Rev. B* 35, 845 (1987).
- Bennett, L. H. and Watson, R. E.; Disclinations: Their relation to the anisotropies of rare-earth hard magnets. *Scripta Metall.* 21, 573 (1987).
- Dariel, M.; Bennett, L. H.; Lashmore, D. S.; Lubitz, P.; Rubinstein, M.; Harford, M. Z.; Lechter, W. L.; Properties of electro-deposited Co-Cu Multilayers. *J. Appl. Phys.* 61, 4067 (1987).
- Massalski, T. B.; Murray, J. L.; Bennett, L. H. and Baker H., eds.; Binary alloy phase diagrams. American Society for Metals, Metals Park, Ohio, 1986).
- Melamud, M.; Bennett, L. H. and Watson, R. E.; Where are the iron atoms and iron moments in RFe_nAl_{12-n} ? A Wigner-Seitz analysis. *J. Appl. Phys.*
- Melamud, M.; Swartzendruber, L. J.; Bennett, L. H.; Cullen, J.; Wun-Fogel, M.; Moment distribution in amorphous magnetic ribbons. *J. Appl. Phys.* 61, 3644 (1987).
61, 4246 (1987).
- Moorjani, K.; Bohandy, J.; Adrian, F. J.; Kim, B. F.; Shull, R. D.; Chiang, C. K.; Swartzendruber and Bennett, L. H.; Superconductivity in bulk and thin films of $La_{1.85}Sr_{0.15}CuO_{4-x}$ and $Ba_2YCu_3O_{7-y}$. *Phys. Rev. B* 36, 4036 (1987).
- Rubinstein, M.; Bennett, L. H.; Chien, C. L. and Xiao, G.; Magnetism and the observation of NMR lines in hexagonal Al_4Mn and icosahedral Al-Mn alloys. *J. Appl. Phys.* 61 4364 (1987).
- Stauss, G. H.; Rubinstein, M.; Frieble, E. J.; Bennett, L. H. and Schaefer, R. J.; Nuclear magnetic resonance powder patterns in Al_6Mn , Al_4Mn , and $Al_{12}Mn$ polycrystals. *Phys. Rev. B* 35, 2700 (1987).
- Swartzendruber, L. J.; Bennett, L. H. and Ettetdgui, H.; Initial susceptibility studies of rapidly solidified Monel. *Phys.* 61, 3991 (1987).
- Watson, R. E.; Melamud, M. and Bennett, L. H.; Disclinations and magnetism in rare earth-transition metal hard magnets. *J. Appl. Phys.* 61, 3580 (1987).
- Wong-Ng, W.; Roth, R. S.; Swartzendruber, L. J.; Bennett, L. H.; Chiang, C. K.; Beech, F. and Hubbard, C. R.; X-Ray powder characterization of $Ba_2YCu_3O_{7-x}$. *Advanced Ceramic Materials*, 2, 565 (1987).

INDUSTRIAL AND ACADEMIC INTERACTIONS

The research programs of the Metallurgy Division are designed and carried out in support of industrial and scientific needs. Specialized facilities within the Division, including metals processing and nondestructive evaluation, attract scientists from both academic and industrial organizations for cooperative research efforts. Interactions with industry, universities, and professional organizations are viewed as an important element of our work with collaborative programs, consulting and general involvement with outside groups being a long standing practice. For example, the Metallurgy Division has been working for more than 70 years with the steel industry to improve the durability and performance of alloys.

In 1987, the Division performed collaborative research with many private organizations through its Research Associate and Guest Scientist programs and other arrangements. Representative examples of such interactions include:

INDUSTRY

1. ALCOA

A cooperative program with the Alloy Technology Division of ALCOA (Dr. A. K. Vasudevan) and the Corrosion and Wear Group of the Metallurgy Division of NBS (R. Ricker) investigating the stress corrosion cracking behavior of Al-Li and Al-Li-Cu alloys is in progress. The objective of the first phase of this effort is to evaluate the influence of grain boundary precipitate size distribution on the intergranular stress corrosion cracking behavior of these alloys. Samples with identical tensile properties but with the grain boundary precipitate size distribution varying were prepared at ALCOA and tested at NBS.

2. ALCOA

Research has been published on the mechanism of dispersoid formation in Al-Fe-Ni alloys. This research was initiated at the suggestion of G. Hildeman of Alcoa and made use of information supplied by Alcoa.

3. Aluminum Association

The first phase of the cooperative project of NBS and the Aluminum Association has been brought to a successful conclusion with the execution of a plant demonstration of the eddy current sensor developed for measuring temperature of extruded aluminum products during processing. The Aluminum Association and NBS have agreed to continue the project for a second year with the objectives of measuring temperatures in more complex shapes and of obtaining information on the non-uniformity of temperature profiles. Mr. Michael L. Mester will continue as Research Associate for the Aluminum Association.

4. American Iron and Steel Institute

The Nondestructive Characterization Group has continued a strong collaboration with the American Iron and Steel Institute (AISI) during FY 87. The interaction began in 1983 with the signing of a memorandum of understanding and agreement to research and develop ultrasonic approaches for internal temperature distribution and pipe/porosity sensors for control of steel processing. The work on the pipe/porosity has essentially been completed with the successful evaluation of a prototype system in FY 86. The sensor was the recipient of an IR-100 award in FY 87. Research continues with the temperature sensor toward developing imaging approaches for solidifying bodies.

5. ASM International (American Society for Metals)

The technical activities of the joint NBS/American Society for Metals Data Program for alloy phase diagrams are centered at NBS. The editor and associate editor of the Bulletin of Alloy Phase Diagrams are J. B. Clark and B. Burton (both of NBS). Three category editors of the program are working at NBS: J. B. Clark, L. J. Swartzendruber and A. J. McAlister, for Mg-, Fe-, and Al- alloys, respectively.

6. Battelle Columbus Laboratories

A joint activity is underway to prepare a wear atlas from selected literature and research findings at Battelle Columbus Laboratories and NBS. Battelle (W. Glaeser) and NBS (A. W. Ruff) are evaluating 250 publications in wear and friction to select authoritative findings that relate wear and friction with material properties and surface morphology. The findings will be published as an atlas under a co-operative effort that also includes the West German Bundesanstalt fur Materialprufung.

7. Crucible Materials Corp., General Electric Co., and Hoeganaes Corp.

An industry-NBS consortium has been initiated to conduct research on automated measurement and control of powder particle size distributions produced by atomization. Scientists from Crucible Materials, General Electric, and Hoeganaes, which all are companies strongly interested in control of rapidly-solidified alloy powders, are collaborating in this consortium work with NBS scientists. In this research, the NBS Metallurgy Division's high pressure inert gas atomization system is being used to develop real-time measurements and feedback systems to allow control of size distributions in atomized rapidly solidified powder.

8. Deere and Company

A Research Associate Program with Deere and Company (P. A. Swanson) and NBS (L. K. Ives) is concerned with investigating problems connected with the measurement of galling damage and the development of tests to evaluate alloys used in agricultural and industrial equipment where galling wear is a serious problem.

9. FIBA, Inc. and Union Carbide Corporation

A collaborative effort is underway between FIBA, Inc. (P. Horrigan), Union Carbide Corporation (R. Tripolet), and NBS (J. H. Smith) to evaluate use of acoustic emission techniques for use in the periodic inspection of large steel pressure vessels. NBS is in the process of developing specific procedures and test criteria to permit the use of acoustic emission techniques for this application.

10. General Electric Company

A collaborative program with General Electric Company (D. Williams and S. Miller) has been pursued to apply advanced photographic techniques to study the break-up of molten alloys into fine droplets during gas atomization.

11. Luxfer USA, Inc

A collaborative effort between NBS (J. H. Smith) and Luxfer USA, Inc. (G. Waite) is ongoing to determine the extent of cracking in seamless aluminum compressed gas cylinders and to develop a reliable test method for inspecting the cylinders in service.

12. Martin Marietta Corporation

Ward L. Johnson and Haydn N. G. Wadley are collaborating with John Ahearn at Martin Marietta to explore the possibility of detecting threading misfit dislocations at Si-GaAs thin film interfaces using internal friction methods. If successful, it will be considered as a potential sensor approach for controlling interfacial dislocations during molecular beam epitaxy of thin film compound semiconductors on silicon substrates.

13. National Association of Corrosion Engineers (NACE)

The NACE-NBS Corrosion Data Center at NBS (D. Anderson) continues to provide the scientific and technical coordination to the joint program initiated in 1985. The program objective is to collect, evaluate and disseminate corrosion data on engineering materials in computerized format. NACE has assigned two full time Research Associates to support the data center activities. Program tasks are aimed at producing PC software for distribution by NACE. Two software programs have been completed, both based on extensive NACE data surveys. Additional software development programs relate to economics of material selection

for corrosive environments and corrosion thermodynamics. The program is structuring a central data base for compilation of numerical data from a variety of sources which, in turn, will serve as basis for distributed programs emphasizing specific environments, materials and applications. The program is being enhanced by a new activity to introduce expert system concepts.

14. National Physical Laboratory, Delhi, India - S. P. Singhal

Roger B. Clough established a three year collaborative effort on measuring AE spectra from composite failure.

15. Union Carbide Corporation and Taylor-Wharton, Inc.

A collaborative effort is underway between the Linde Division of Union Carbide Corporation (M. Rana), Taylor-Wharton, Inc. (K. Miller), and the Corrosion and Wear Group (J. H. Smith) to develop criteria for the safe design and fabrication of high strength steel, seamless pressure vessels. Criteria have been developed, based on fracture mechanics principles, to permit the use of new, higher strength steels for the construction of pressure vessels without reducing the level of safety of these vessels.

16. Welding Research Council (WRC)

An interpretive report for the Pressure Vessel Research Committee on Effects of Hydrogen in Steels is being prepared by C.G. Interrante of NBS for publication as a WRC Bulletin.

17. Zimmer Company

A collaborative study with Zimmer Company, Warsaw, Indiana was carried out by Anna C. Fraker to determine mechanical properties of the surgical implant alloy, Ti-6Al-4V. Transmission electron microscopy was conducted to investigate microstructural changes caused by small variations in oxygen content and other minor compositional constituents.

INDUSTRY/UNIVERSITY

1. BHABHA Atomic Research Center (Government of India)
University of Poona/University of Roorkee

A cooperative project is underway with the BHABHA Atomic Research Center (Dr. C. K. Gupta), the University of Poona (Dr. A. P. B. Sinha) and the University of Roorkee (Dr. M. L. Mehta). This project is part of the Indo-US Physical, Materials and Marine Sciences Collaboration Program and the objective of this project is to study the influence of nitrogen content on the stress corrosion cracking behavior of stainless steels (alloy 316L). NBS has provided material for this study and complementary experiments will be conducted at the various institutions.

2. National Bureau of Standards Metals Processing Laboratory

The Metals Processing Laboratory of the National Bureau of Standards contains facilities for preparation of special samples not readily obtainable elsewhere. Scientists from industry and universities can come to NBS to help prepare samples for independent or collaborative research. During the past year investigators from Cominco, Metcut, Lockheed, Bureau of Mines, Air Force Materials Laboratory, Johns Hopkins University, University of California, and University of Wisconsin have participated in interactions in this program.

3. Rhone Poulenc, Inc./University of Lyon, France

Under the sponsorship of the French company Rhone Poulenc, Inc., and in cooperation with the University of Lyon (Professor Mazille), a French graduate student (R. Rothea) spent sixteen months at NBS to study the use of acoustic emission to detect, and possibly identify, different corrosion and stress corrosion processes on stainless steels.

UNIVERSITIES

1. Applied Physics Laboratory, The Johns Hopkins University

A collaborative effort is underway between the Applied Physics Laboratory of the Johns Hopkins University (K. Moorjani) and NBS (R. Shull) to prepare and investigate the magnetic behavior of composite materials having nanocrystalline-sized grains.

2. Cornell University

Roger B. Clough is discussing collaborative effort with Prof. S. L. Phoenix on statistical analysis of fiber composite failure.

3. Iowa State University

Theoretical work on the inclusion of non-equilibrium interface conditions into alloy dendritic growth theory has been published in collaboration with Professor R. Trivedi of Iowa State University.

4. Johns Hopkins University

Studies on the mechanism of transgranular stress corrosion cracking are being pursued in cooperation with Johns Hopkins University (Dr. J. Kruger). The experimental part is being carried out at NBS by a graduate student (T. Cassagne), and the staff of the Corrosion and Wear Group is involved both in the experiment and in the analysis of the results.

5. Johns Hopkins University

A collaborative effort with Johns Hopkins University (D. Shechtman) which resulted in the discovery of an entirely new class of materials, quasicrystals, is continuing in order to investigate the processing conditions which produce these special alloys.

6. Rensselaer Polytechnic Institute

A joint research program on interface interactions in Si-Ge multilayers has been initiated with K. Rajan of Rensselaer Polytechnic Institute. The effects of stresses at sharp interfaces is being investigated for applications to composite systems.

7. University of Maryland

The University of Maryland (R. W. Armstrong) and NBS (R. Polvani) have collaborated on a study of ignition of energetic materials. Theory can be used to show dislocation motion is a likely cause for "hot spot" formation and subsequent ignition. However, the competition between plasticity and cleavage deformation that occurs in RDX, a typical energetic material, is a major complication for this theory. The NBS Dynamic Microindentation Instrument is a tool uniquely suited for studying the effect of load and rate on the location of the ductile-brittle transition in RDX type materials.

8. University of Wisconsin at Madison

Collaboration with Professor J. Perepezko (U. of Wisconsin) and his graduate students has resulted in the publication of two scientific papers on microstructure development in TiAl and the thermal decomposition of quasicrystals in Al-Mn alloys.

TECHNICAL/PROFESSIONAL COMMITTEE LEADERSHIP ACTIVITIES

ACTIS Technical Advisory Committee

M. B. Peterson

American Association for Crystal Growth

S. R. Coriell, Executive Committee

American Electroplaters Society

Alloy Deposition Handbook

D. S. Lashmore, Editor

American Institute of Mining, Metallurgical and Petroleum Engineers

The Metallurgical Society

J. B. Clark, The Physical Metallurgy Committee

J. B. Clark, The Physics and Chemistry of Materials Committee

R. Ricker, Committee on Corrosion and Environmental Effects

American Society for Metals (ASM International)

Materials Science Division

R. Ricker, Committee on Corrosion and Environmental Effects

NDT Committee

H. N. G. Wadley

Subcommittee on Metallurgical Reactions and Electromigration in
Electronic Devices

C. A. Handwerker, Chairman

Washington, DC Chapter - Executive Committee

R. Ricker, Chairman, Educational Committee

A. W. Ruff, Chairman, Program Committee

American Society for Testing and Materials

B7: Light Metals and Alloys; Aluminum Alloy Ingots and
Castings

B7.07.09: Conversion Coatings on Aluminum

D. S. Lashmore, Chairman

B8: Electrodeposited Coatings

B8.01: Terminology, Editing Public Relations and Metrication

WG.05: D. S. Lashmore, Metrication Chairman

B8.06: Chemical Conversion Coatings

D. S. Lashmore, Subcommittee Chairman

B8.10.03: General Test Methods for Microhardness

C. E. Johnson, Liaison to EO4

E3: Chemical Analysis of Metals

E3.07: Acoustic Emission

R. C. Clough

- E7: Nondestructive Testing
Joint Task Group on Acoustic Emission; System Calibration
J. A. Simmons, Chairman

- E24: Fracture Testing
C. G. Interrante, Member of Executive Committee
- E24.05: Terminology for Fracture Testing
C. G. Interrante, Co-Chairman

- E49 Computerization of Material Property Data
- E49.02.5: Corrosion Data Formats
D. B. Anderson, Chairman

- F4: Medical and Surgical Materials and Devices
- F4.G1: Joint Section on Corrosion of Implants
A. C. Fraker, Co-Chairperson

- F7: Aerospace Industry Methods
- F7.04: Hydrogen Embrittlement Testing
C. G. Interrante, Chairman, Task Group on Terminology

- G1: Corrosion of Metals
D. B. Anderson, Liason to ASTM Committee E-49

- G1.03.1: Corrosion Data Formats Task Group
D. B. Anderson, Chairman

- G1.06: SCC and Corrosion Fatigue
R. Ricker

- G1.10: Corrosion of Metals in Soil
E. Escalante

- G1.10.1 Measurement of pH of Soil
E. Escalante, Task Group Leader

- G1.10.2: Measurement of Soil Resistivity
E. Escalante

- G1.11: Electrochemical Measurements in Corrosion
R. Ricker

- G1.14: Corrosion of Steel in Concrete
E. Escalante

- G2: Erosion and Wear
- G2.2: Solid Particle Erosion
A. W. Ruff, Task Group Leader

- G2.9: Executive Subcommittee Task Group on Operations
A. W. Ruff, Chairman

ASTM Committee on Light Metals

R. D. Shull, Member

W. J. Boettinger, Member

ASTM Committee on Nondestructive Testing

L. J. Swartzendruber, Member

L. H. Bennett, Member

ASTM Standing Committee on Terminology

C. G. Interrante, Technical Committee Representative

ASM INTERNATIONAL

Alloy Phase Diagram Data Committee

J. B. Clark, Chairman

Materials Science Division Council

J. B. Clark

American Institute of Mining, Metallurgical and Petroleum Engineers

The Metallurgical Society

J. B. Clark, The Physical Metallurgy Committee

J. B. Clark, The Physics and Chemistry of Materials Committee

American Society of Mechanical Engineers

Tribology Division, Executive Committee

A. W. Ruff

Research Committee on Tribology

M. B. Peterson, Chairman

A. W. Ruff

Wear of Materials Conference Steering Committee

A. W. Ruff

Department of Energy ECUT Tribology Program

M. B. Peterson, Chairman, Advisory Panel

Electrochemical Society

Editorial Committee

U. Bertocci, Division Editor

Electrodeposition Division

D. S. Lashmore, Secretary-Treasurer

Industrial Electrolytic Division

D. E. Hall, Executive Committee

Publicity Committee

D. E. Hall

Sensors Symposium Organizing Committee

D. E. Hall

Federation of Materials Societies

S. R. Coriell, Trustee

Instrument Society of America

S. J. Norton, Session Organizer, 1986 Annual International Meeting

International Advisory Committee and Program Committee for International
Conference on Rapidly Quenched Metals

W. J. Boettinger, Member

International Institute for the Science of Sintering

P. W. Voorhees, Corresponding Member

International Organization for Standardization

TC164: Mechanical Testing

1. Terminology

C. G. Interrante, Delegate

International Standards Organization

TC107: Metallic and Other Non-Organic Coatings

C. E. Johnson, Delegate

D. S. Lashmore, Delegate

2: Methods of Inspection and Coordination of Test
Methods

C. E. Johnson, Delegate

D. S. Lashmore, Delegate

3: Electrodeposited Coatings and Related Finishes

C. E. Johnson, Delegate

D. S. Lashmore, Delegate

Maryland Institute of Metals

W. J. Boettinger, Executive Board Member

Materials Science and Engineering

L. H. Bennett, Associate Editor

National Association of Corrosion Engineers (NACE)

Baltimore-Washington Chapter Executive Committee

R. Ricker, Membership Committee Chairman

Corrosion '86 Symposium on New Electrochemical Techniques

R. Ricker, Reviewer

CORROSION - The Journal of Science and Engineering

R. Ricker, Journal Reviewer

Review Board for the Journal: Materials Performance

R. Ricker

T.1 Corrosion Control in Petroleum Production

T.1D Corrosion Control by Chemical Treatment

R. Ricker, Unit Committee

- T.1D.26 The Role of Bacteria in Corrosion
 R. Ricker, Task Group
- T.3 Corrosion Science and Technology Committee
T.3E R. Ricker, Unit Committee on SCC and Corrosion Fatigue
- T.3K Corrosion and Other Deterioration Phenomenon Associated
 with Concrete
 E. Escalante
- T.3L R. Ricker, Unit Committee on Electrochemical Techniques
- T.3.2 Formats for Computerized Corrosion Information
 D. B. Anderson, Chairman

1986 Conference on Magnetism and Magnetic Materials

- L. H. Bennett, Member, Local committee
L. H. Bennett, Local Treasurer

National Research Council

- Transportation Research Board Evaluating Corrosion Effects in
Steel Bridges
E. Escalante, Panel Member

Office of Energy-Related Inventions, National Bureau of Standards

- L. H. Bennett, Reviewer of Invention Disclosures
J. H. Smith, Reviewer of Invention Disclosures

Read Research Conferences

- Organizing Committee
D. S. Lashmore, Member

Society for Automotive Engineers

- Committee on Automotive Trim
D. S. Lashmore, Invited Member

Society for Biomaterials Standards

- A. C. Fraker, Chairperson, Representative

Society of Automotive Engineers/American Society of Testing and Materials
Unified Numbering System for Metals and Alloys

- L. H. Bennett, NBS Representative

Versailles Advanced Materials and Standards

- Subcommittee on Wear
A. W. Ruff, U.S. Representative

EXTERNAL RECOGNITION AND AWARDS

M. P. Peterson: 1987 Mayo D. Hersey Award of the American Society for
Mechanical Engineers

M. Linzer and H. N. G. Wadley: IR-100 Award for "Ultrasonic Pipe Porosity
Sensor"

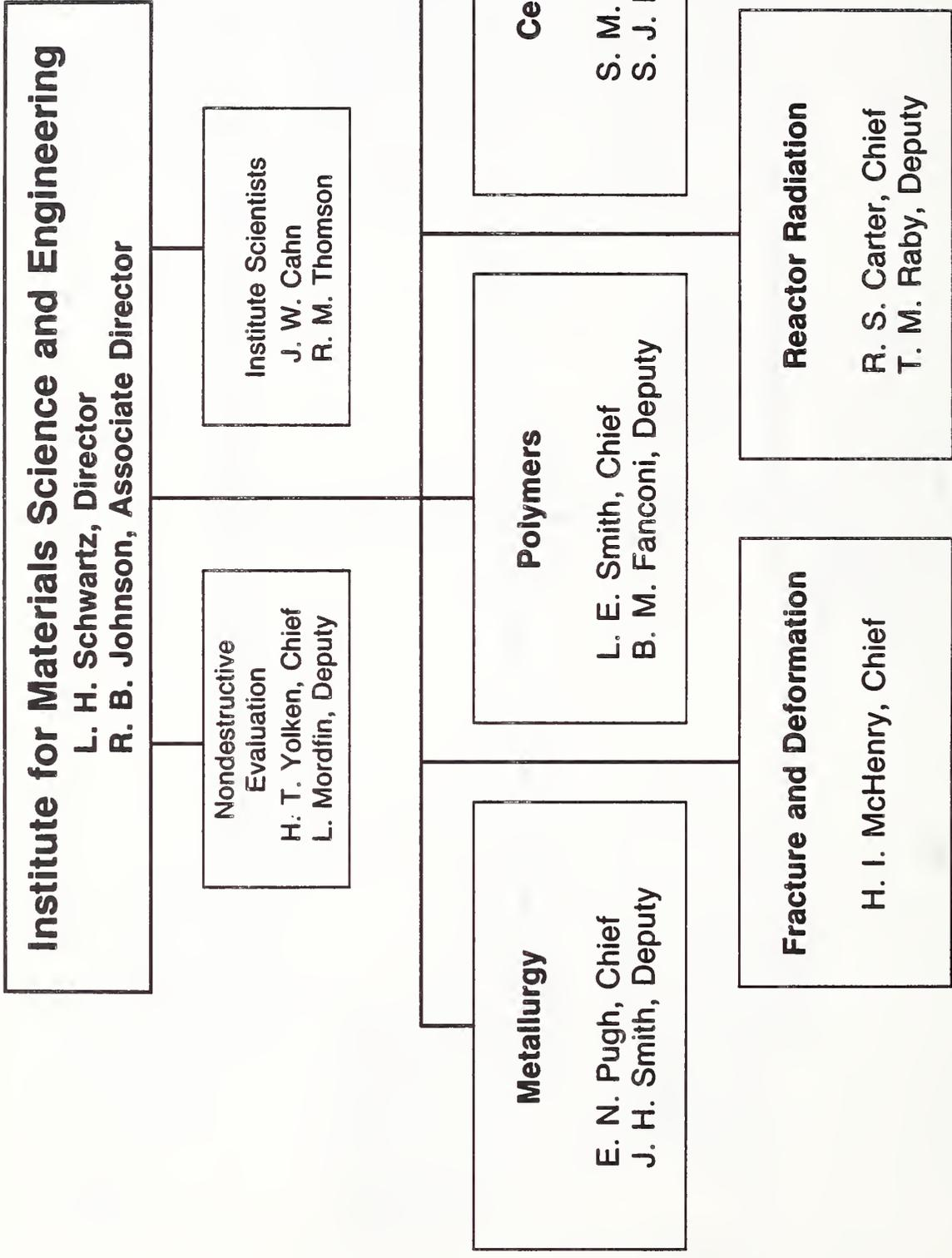

| | | | |
|--|--|---|--|
| U.S. DEPT. OF COMM. BIBLIOGRAPHIC DATA SHEET (See instructions) | 1. PUBLICATION OR REPORT NO. NBSIR 87-3615 | 2. Performing Organ. Report No. | 3. Publication Date October 1987 |
| 4. TITLE AND SUBTITLE Metallurgy Division Annual Report 1987 NBSIR 87-3615 | | | |
| 5. AUTHOR(S) | | | |
| 6. PERFORMING ORGANIZATION (If joint or other than NBS, see instructions) NATIONAL BUREAU OF STANDARDS U.S. DEPARTMENT OF COMMERCE GAITHERSBURG, MD 20899 | | 7. Contract/Grant No. 8. Type of Report & Period Covered | |
| 9. SPONSORING ORGANIZATION NAME AND COMPLETE ADDRESS (Street, City, State, ZIP) | | | |
| 10. SUPPLEMENTARY NOTES <input type="checkbox"/> Document describes a computer program; SF-185, FIPS Software Summary, is attached. | | | |
| 11. ABSTRACT (A 200-word or less factual summary of most significant information. If document includes a significant bibliography or literature survey, mention it here) <p>This report summarizes the FY 1987 activities of the Metallurgy Division of the National Bureau of Standards. The research centers upon the structure-processing-properties relations of metals and includes alloys and on the methods of their measurement. The activities also include the generation and evaluation of critical materials data. Efforts comprise studies of metallurgical processing, corrosion and wear, chemical metallurgy, electrodeposition, nondestructive characterization and magnetic materials.</p> <p>The work described also includes three cooperative programs with American professional societies and industry: the American Society for Metals (ASM) - NBS Alloy Phase Diagram Program, the National Association of Corrosion Engineers (NACE) - NBS Corrosion Data Program, the American Iron and Steel Institute (AISI) - NBS Steel Sensor Program, and the Aluminum Association.</p> <p>Work in support of other government agencies includes a major program to assist the Nuclear Regulatory Commission in addressing the critical national problem of disposing of high level nuclear waste in geologic repositories.</p> <p>The scientific publications, committee participation, and other professional interactions of the 72 full-time and part-time permanent members of the Metallurgy Division and its 40 guest researchers are identified.</p> | | | |
| 12. KEY WORDS (Six to twelve entries; alphabetical order; capitalize only proper names; and separate key words by semicolons) Annual report; industrial interactions; Metallurgy Division; metals, publications; technical activities | | | |
| 13. AVAILABILITY <input checked="" type="checkbox"/> Unlimited <input type="checkbox"/> For Official Distribution. Do Not Release to NTIS <input type="checkbox"/> Order From Superintendent of Documents, U.S. Government Printing Office, Washington, D.C. 20402. <input checked="" type="checkbox"/> Order From National Technical Information Service (NTIS), Springfield, VA. 22161 | | 14. NO. OF PRINTED PAGES 107 15. Price \$ 18.95 | |

