

Reference

NBS
Publi-
cations

-2495



A11106 048284

Conservation and Substitution Technology for Critical Materials Volume I

Proceedings of Public Workshop sponsored by
U.S. Department of Commerce/National Bureau of Standards
and U.S. Department of the Interior/Bureau of Mines

15-17 June 1981

Vanderbilt University
Nashville, TN

April 1982

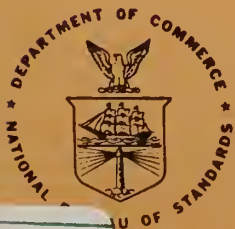

DEPARTMENT OF COMMERCE
NATIONAL BUREAU OF STANDARDS

QC
100
.U56
32-2495
V.1
1982

NATIONAL BUREAU
OF STANDARDS
LIBRARY
MAR 15 1983

NBSIR 82-2495

**CONSERVATION AND SUBSTITUTION
TECHNOLOGY FOR CRITICAL MATERIALS
VOLUME I**

Proceedings of Public Workshop sponsored by
U.S. Department of Commerce/National Bureau of Standards
and U.S. Department of the Interior/Bureau of Mines

15-17 June 1981

Vanderbilt University
Nashville, TN

General Chairman:

Allen G. Gray
American Society for Metals
Adjunct Professor of Metallurgy
Vanderbilt University

Workshop Coordinator:

Robert T. Nash
School of Engineering
Vanderbilt University
Nashville, TN

April 1982

U.S. DEPARTMENT OF COMMERCE, Malcolm Baldrige, *Secretary*
NATIONAL BUREAU OF STANDARDS, Ernest Ambler, *Director*

TABLE OF CONTENTS

VOLUME I	<u>Page</u>
I. Foreword	F 1
II. Table of Contents	TC1

Workshop Keynote Address

- (1) OPPORTUNITIES IN CONSERVATION AND SUBSTITUTION TECHNOLOGY FOR CRITICAL MATERIALS, Allen G. Gray, American Society for Metals P 1

Current Activities in Substitution

- (2) TECHNICAL ACTIVITIES AT THE NATIONAL BUREAU OF STANDARDS RELATED TO SUBSTITUTION AND CONSERVATION, John B. Wachtman, Jr., Center for Materials Science, National Bureau of Standards. P 2
- (3) CURRENT ACTIVITIES IN SUBSTITUTION, UNITED STATES DEPARTMENT OF INTERIOR, BUREAU OF MINES, Ralph C. Kirby, Mineral Resources Technology Division. P 3
- (4) NASA'S ACTIVITIES IN CONSERVATION OF STRATEGIC AEROSPACE MATERIALS, Joseph R. Stephens, NASA--Lewis Research Center. P 4
- (5) CHARGE TO WORKSHOP IN RELATION TO MATERIALS POLICY LEGISLATION (PL 96-479), John B. Wachtman, Jr., National Bureau of Standards. P 5

Chromium--Substitution and Conservation

- (6) CONSERVING CHROMIUM, David C. Goldberg, Westinghouse Electric Corporation. P 6
- (7) COMPUTER SYSTEMS FOR DEVELOPING CHROMIUM FREE STEELS FOR HARDENABILITY, Dale H. Breen, International Harvester Co. P 7
- (8) SUBSTITUTIONS FOR CHROMIUM IN STEELS FOR COIL SPRINGS, S. T. Furr, Bethlehem Steel Corp. P 8
- (9) AN UPDATE ON FE-MN-AL STEELS AS A REPLACEMENT FOR NI-CR STAINLESS STEELS, Samir K. Banerji, Foote Mineral Co. P 9
- (10) SUBSTITUTE STAINLESS STEELS WITH LESS CHROMIUM, Joseph A. Douthett, Armco, Inc. P10
- (11) SUBSTITUTION OF MODIFIED 9CR-1MO STEEL FOR AUSTENITIC STAINLESS STEELS, Vinod Sikka, Oak Ridge National Laboratory. P11

Cobalt--Substitution and Conservation

- (12) COBALT, A VITAL ELEMENT IN THE AIRCRAFT ENGINE INDUSTRY, Joseph R. Stephens, NASA--Lewis Research Center. P12
- (13) REDUCTION OF COBALT IN GAS TURBINE ENGINES, Dennis J. Evans, Pratt & Whitney Aircraft Group. P13
- (14) ROLE OF COBALT IN ASTROLOY (SUPERALLOY), John K. Tien and Robert N. Jarrett, Columbia University. P14
- (15) PROGRESS IN REDUCTION OF COBALT IN MAR-M247, Michael Nathal, Case Western Reserve University/NASA--Lewis Research Center P15
- (16) SUBSTITUTION FOR COBALT IN HIGH SPEED STEELS--ROLE OF PROCESSING INNOVATION, Walter T. Haswell, Jr., Colt Industries, Crucible Inc. P16
- (17) SUBSTITUTION FOR COBALT IN MAGNETIC ALLOYS, Thomas D. Schlabach, Bell Telephone Laboratories P17
- (18) BORONIZING AS A SUBSTITUTE FOR COBALT BEARING ALLOYS, Stanley R. Scales, Hughes Tool Co. P18

Titanium--Substitution and Conservation

- (19) TECHNOLOGICAL OPPORTUNITIES FOR A MORE STABLE SUPPLY OF TITANIUM, Harris M. Burte, Air Force Materials Laboratory P19
- (20) ISOSTATIC PRESSING OF COMPLEX SHAPES FROM TITANIUM AND TITANIUM ALLOYS, Stanley Abkowitz, Dynamet Technology Inc. P20
- (21) BENEFITS OF TITANIUM IN AIRFRAMES AND COMPROMISES IN SUBSTITUTION, Donald G. Goehler and Lew Wingert, Boeing Commercial Airplane Co. P21

Tantalum--Substitution and Conservation

- (22) TANTALUM AND OTHER CRITICAL ELECTRONIC MATERIALS, Thomas D. Schlabach, Bell Telephone Laboratories. P22
- (23) TANTALUM IN HIGH TEMPERATURE ALLOYS, James A. Ford and Robert B. Herchenroeder, Cabot Corporation. P23

Technological Opportunities for
Conservation of Critical Metals Utilizing
Metallurgical Coating Systems

- | | | |
|------|--|-----|
| (24) | A PRESENTATION AT THE "WORKSHOP ON CONSERVATION AND SUBSTITUTION TECHNOLOGY FOR CRITICAL MATERIAL," David S. Duvall, Pratt & Whitney Aircraft Group. | P24 |
| (25) | POTENTIAL FOR HARD FACING APPLICATION TECHNOLOGY TO CONSERVE CRITICAL METALS, Steve J. Matthews, Cabot Corporation. | P25 |
| (26) | POTENTIAL FOR CLADDINGS TO CONSERVE CRITICAL METALS, James M. Glazebrook, Lukens Steel Co. | P26 |
| (27) | CONSERVATION OF CRITICAL METALS UTILIZING SURFACE ALLOYING, Ray J. Van Thyne, Dilex Systems | P27 |
| (28) | ELECTRON BEAM IRRADIATION APPLIED TO CONSERVATION OF CRITICAL MATERIALS, Joe E. Jenkins, Leybold-Heraeus Vacuum Systems, Inc. | P28 |
| (29) | APPLICATION OF THERMAL SPRAYING PROCESSES TO CONSERVE CRITICAL MATERIALS, Edward R. Novinski, METCO, Inc. | P29 |

Opportunities for Conservation and Substitution of
Critical Metals Utilizing Rapid Solidification
Technology and Near Net Shape Processing

- | | | |
|------|---|-----|
| (30) | OPPORTUNITIES FOR CONSERVATION AND SUBSTITUTION OF CRITICAL METALS UTILIZING RAPID SOLIDIFICATION TECHNOLOGY AND NEAR NET SHAPE PROCESSING, Arden L. Bement, Jr., TRW, Inc. | P30 |
| (31) | POTENTIAL OF RAPID SOLIDIFICATION FOR REDUCTION OF CRITICAL ELEMENT CONTENT OF JET ENGINE COMPONENTS, Joseph Moore and Colin Adam, Pratt & Whitney Aircraft Group. | P31 |
| (32) | POTENTIAL OF RAPID SOLIDIFICATION FOR WROUGHT P/M ALUMINUM ALLOYS, Walter S. Cebulak, Aluminum Company of America. | P32 |
| (33) | POTENTIAL FOR NEAR NET SHAPES, J. Stanley Mosier and Peter G. Bailey, General Electric Company | P33 |
| (34) | OUTLOOK FOR AS-HIP'ED NEAR NET SHAPES, John Moll, Colt Industries, Crucible Research Center. | P34 |

Technological Opportunities to More Fully Utilize
Metals with Domestic Sources or Near Domestic
Sources as Substitutes for Critical Metals

- (35) TECHNOLOGICAL OPPORTUNITIES TO MORE FULLY UTILIZE METALS WITH DOMESTIC SOURCES OR NEAR DOMESTIC SOURCES AS SUBSTITUTES FOR CRITICAL METALS, Horace N. Lander, Molybdenum Co. P35
- (36) MOLYBDENUM AS A SUBSTITUTE FOR CRITICAL METALS, Ralph M. Davison, Climax Molybdenum Co. P36
- (37) NICKEL AS A SUBSTITUTE FOR METALS IN CRITICAL SUPPLY, Robert J. Johnson, International Nickel Co. P37
- (38) TUNGSTEN--A NEWLY NONCRITICAL METAL, C. C. Clark, AMAX Tungsten. P38
- (39) NEW APPLICATIONS OF VANADIUM IN STEELS TO SAVE COST, ALLOYING AND ENERGY, P. L. Mangonon, Foote Mineral Co. P39
- (40) NEW RECLAMATION PROCESS FOR CRITICAL METALS, William J. Boesch, Special Metals, Inc. P40

Role of Composites in Substitution, Conservation
and Displacement of Critical Materials

- (41) THE ROLE OF COMPOSITES IN SUBSTITUTION, CONSERVATION, AND DISPLACEMENT OF CRITICAL MATERIALS, Alfred E. Brown, Celanese Corp. P41
- (42) ROLE OF COMPOSITES IN SUBSTITUTION, CONSERVATION, AND DISPLACEMENT OF MATERIALS AND POTENTIAL FOR SUBSTITUTION IN MILITARY AND COMMERCIAL AEROSPACE, Richard N. Hadcock, Grumman Aerospace Corp. P42
- (43) POTENTIAL FOR SUBSTITUTION IN ALL USES OTHER THAN AIRCRAFT? AEROSPACE, John P. Riggs, Celanese Corp. P43

Substitution Preparedness--
Information Stockpile on Substitution Technology

- (44) SUBSTITUTION PREPAREDNESS--INFORMATION STOCKPILE ON SUBSTITUTION TECHNOLOGY, A. O. Schaefer, Metal Properties Council. P44
- (45) INFORMATION ANALYSIS CENTERS AND SUBSTITUTION TECHNOLOGY, Harold Mindlin, Battelle Columbus Laboratories. P45
- (46) INFORMATION AS AN ESSENTIAL ASPECT OF CONSERVATION, H. David Chafe, American Society for Metals. P46
- (47) FACTORS INFLUENCING A NATIONAL MATERIALS SUBSTITUTION INFORMATION DATA BASE, Maurice A. H. Howes, ITT Research Institute. P47

- (48) INFORMATION REQUIREMENTS WHEN FACED WITH A MATERIAL SHORTAGE, Bruce E. Boardman, Deere & Company. P48
- (49) SUBSTITUTION PREPAREDNESS--THE INFORMATION STOCKPILE ON SUBSTITUTION TECHNOLOGY, John Rumble, National Bureau of Standards. P49
- (50) REQUIREMENTS FOR AN INFORMATION STOCKPILE ON SUBSTITUTION TECHNOLOGY, Frank M. Richmond, Universal-Cyclops Specialty Steel Div. P50
- (51) SUBSTITUTION PREPAREDNESS--ROLE OF COLLEGES AND UNIVERSITIES, Ellis D. Verink, Jr., University of Florida. P51
- (52) SUMMARY AND OVERVIEW OF WORKSHOP, N. E. Promisel, Consultant and Allen G. Gray, General Chairman. S 1
- (53) SUMMARY OF FINDINGS SF1
- (54) SUMMARY OF RECOMMENDATIONS R 1
- (55) PROCESS EMPLOYED TO DEVELOP THE FINDINGS AND RECOMMENDATIONS PRI
- (56) WRITTEN SUBMISSION TO WORKSHOP, James I. Mueller, President, American Ceramic Society. W 1

FOREWORD

As is noted in the Charge to Workshop (pg. P5) presented by John B. Wachtman Jr., of Department of Commerce/National Bureau of Standards, which cosponsored the event with Department of the Interior/U. S. Bureau of Mines, this Public Workshop was held to assist in the preparation of a report to Congress required by a law passed in October 1980, the National Materials and Minerals Policy, Research and Development Act of 1980. As stated by Dr. Wachtman, the Act requires separate reports from the Department of Commerce (DOC) and the Department of Defense (DOD), both due for delivery to the Congress on 1 October 1981. The Act also assigns other responsibilities to the Department of the Interior and to the President's Office of Science and Technology.

The Workshop was held principally to develop information for the report required by the Department of Commerce, but should also be useful to the other agencies in their responsibilities. The DOC report is supposed to identify a materials needs case related to national security, economic well-being, and industrial productivity, to assess critical materials needs, and to recommend programs to meet these needs.

The United States is highly vulnerable to problems in supply of critical and strategic materials and it is recognized that there is a whole spectrum of options for responding to such crises. While a number of supply oriented options are under study by various groups, the focus of this Workshop was on the technical options.

The Workshop was developed with the premise that the availability of technology for substitution, conservation and displacement is among the most viable options for reducing this country's vulnerability to cut-off in supply of critical materials. Likewise, consideration was given to the development of the concept of "substitution preparedness" which would provide for stockpiling

of information on substitution and on the technology for conservation and displacement with advanced materials.

Thus the Workshop goals were:

1. Define technical opportunities for substitution, conservation and displacement of four selected critical imported materials -- chromium, cobalt, tantalum and titanium.
2. Identify requirements for an "Information Stockpile."
3. Consider the potential for advanced materials, for metallurgical coating systems, and for fuller use of domestic or near domestic resources. Explore views on federal actions that would be desirable to facilitate the development of these potentials.

This report includes the formal papers presented at Workshop sessions. During the Workshop information was obtained from the participants and the attendees employing a process referred to as brainwriting. Through this procedure, written responses to carefully developed questions were obtained for each session during the Workshop. Immediately following the Workshop, all the findings and candidate recommendations developed in the brainwriting process were sent to the 180 people who attended for evaluation. The summary of findings and recommendations from the brainwriting process is presented in the report. Likewise, an overview/summary of the Workshop is presented and a written submission from the President of the American Ceramic Society is included.

Allen G. Gray
General Chairman of Workshop

OPPORTUNITIES IN CONSERVATION AND SUBSTITUTION TECHNOLOGY
FOR CRITICAL MATERIALS

Allen G. Gray
American Society for Materials

KEYNOTE ADDRESS

Opportunities in Conservation and Substitution
Technology for Critical Materials

By

Dr. Allen G. Gray
Technical Director
American Society for Metals
Metals Park, Ohio 44073

General Chairman of Workshop and
Adjunct Professor of Metallurgy
Vanderbilt University

Presented at

Public Workshop on Conservation and
Substitution Technology for Critical Materials

Sponsored By

U.S. Department of Commerce/National Bureau of Standards
U. S. Department of the Interior/Bureau of Mines

Vanderbilt University
Nashville, Tennessee
15 June 1981

It's not news to those of you who are participating in this Workshop that the United States is heavily dependent on foreign sources for supplies of key materials that are essential to the nation's defense and for the operation of its vital industries. For example, this country imports almost 100 percent of the strategic aerospace metals, cobalt, chromium, columbium, tantalum and manganese.

Over-all the U. S. is dependent on foreign sources for 22 of the 27 metals considered vital to this country's economy. The problem affects U. S. industry over-all as much as aerospace and potential defense needs. However, until recently there has been all too little awareness of our enormous dependence on foreign sources of critical nonfuel minerals.

Aside from the fact that without chromium we cannot make an efficient durable gas turbine engine, the metal has many important industrial applications: oil refineries, petrochemicals, conventional and nuclear power plants, tanker trucks, industrial machinery and all stainless steels.

The essential nature of critical and strategic metals requires that all options to provide supplies or alternatives must be pursued. On the supply side, effective steps are being taken to strengthen the strategic stockpile and develop domestic resources. The development of alternatives requires that viable materials technology options derived from substitution, conservation, enhanced performance, coating systems and reclamation be available at reasonably acceptable costs.

It should be noted that the need for high performance alloy steels, stainless steels and superalloys requiring the strategic aerospace metals is increasing as demands have grown for higher durability, plus higher performance fuel efficient aircraft turbine engines. An example is the prospect for increased requirements for tantalum in single crystal turbine blades which will be discussed in a Workshop session.

Likewise, it should be pointed out that a transfer of aerospace high temperature technology will be a major asset in the development of this country's alternative energy programs including coal gasification and liquefaction, even deep well exploitation of domestic oil resources. It's significant that extensive tests on alloys for these uses conducted by the Metal Properties Council have shown that a minimum chromium content of 25% is required for long term service.

This adds emphasis to the strategic importance of chromium which is among the critical metals considered in the Workshop Program. Chromium continues to appear more critical than the other critical metals, and seems less secure than ever before. Unless we develop alternative materials technologies, a cutoff of oil supply and chromium supply would attack this country on two fronts.

As a sidelight on this issue, I might say that in an article in TIME magazine entitled, "Strategic Metals, Critical Choices," published last year, I was quoted as Technical Director, American Society for Metals, that "A cutoff of our chromium supply could be even more serious than a cutoff in our oil supply. We do have some oil but almost no chromium."

The pursuit of our most important national goals dictates that we be concerned about materials availability and that we implement an enlightened National Materials Policy which requires the development of alternatives and contingency plans which include the technology available for substitution and conservation in the event of a materials crisis.

Although the public is coming to understand that the U. S. faces a serious and growing difficulty in assuring a supply of critical materials that are essential for the nation's defense and for the operation of its vital industries, historically the U. S. has addressed the issue of critical materials policy only after shortages have affected manufacturing capabilities.

The theme of this Workshop is that technology is among the most viable options for reducing this country's vulnerability to

the potential of foreign minerals cartels. Also the message is clear that the time to start to develop these technologies for improved materials performance and processing, substitutions, conservation, coatings systems and reclamation is now.

I believe we will all agree that the best time to develop options to deal with our vulnerability is to decide with a cool calculated logic what to do when we have no immediate emergency or short supply. This is what E. F. Andrews, Vice President, Materials and Services, Allegheny International Inc., and a long time supporter of a National Materials Policy, told executives of forge companies recently at their annual meeting.

This workshop is offered as a contribution to the national effort on the issue of materials dependency. It's encouraging that the Reagan Administration has informed itself of the problem and appears to be prepared to take effective steps to deal with it.

Hearings were held in the U. S. Senate earlier this year on the National Materials and Minerals Policy Research and Development Act of 1980 (P.L. 96-479) (signed by President Carter on Oct. 21, 1980) to assess progress being made in dealing with the nation's critical shortages of strategic materials. At these hearings one of the questions that was raised was: What steps are required, or are we prepared to take, if the nation were confronted with a military or economic interruption of foreign supplies of strategically important minerals and materials?

The objective of the Workshop is to provide input for a report on materials needs that the Secretary of Commerce is required to present to Congress before October 1981, as well as to point out future directions for study and action in meeting critical materials

challenges. The report is part of the requirements specified by the recently enacted National Materials Policy, Research and Development Act of 1980 (P.L. 96-479), and Dr. John Wachtman of National Bureau of Standards will comment on this specifically.

At this point, I would like to emphasize the importance of developing a substitution potential for critical materials, since I have been a strong proponent of efforts to foster the substitution initiative in testimony on the National Materials Policy Bill in the U. S. Senate in July last year, and in the U. S. House of Representatives shortly after the bill was introduced.

In my testimony I proposed that the United States should embark on an organized effort to foster and support research and development programs that will advance the practical application of substitution technology to reduce the impact of supply interruptions in critical metals, particularly chromium and cobalt.

Likewise, it's evident that a plan should be developed to document known substitution technologies and "stockpile" this information. The final session of this Workshop will be devoted to viewpoints and discussion on what form this information stockpile should take to provide optimum value in "substitution preparedness."

As R & D programs are developed to plug gaps and create new options for substituting for critical metals, this technological information would be added to the information stockpile.

As a spokesman for "substitution preparedness," which is how I referred to my recommendations in the Congressional testimony, I emphasized that it is essential that appraisal and recording of substitution procedures in specific applications be as complete as available information allows.

Needs for additional information should be identified and defined so that research and development projects can be assigned to gather data required to expand capabilities in those areas which appear to be sound and achievable with available means,

It should be noted that leadtime is very short in an emergency situation. Thus a stockpile of information on substitution technology is also a stockpile of time, and a valuable yet relatively low cost supplement to the commodity stockpile.

Substitution programs should be an important part of strategic materials planning for individual manufacturing firms. In presentations before company management groups concerned with strategic materials planning, I have encouraged the development of substitution programs and pointed out that the objectives of a national initiative on substitution can be applied to internal (company) substitution R & D programs.

My recommendations for materials substitution and conservation initiatives, included as a part of my testimony in U. S. Senate hearings last July, are summarized below:

1. Find out just how much we know about substitutes for the most critical strategic metals, particularly chromium, cobalt, manganese, columbium, tantalum and platinum group metals.
2. Appraise the reliability of the information that is available on substitutes for these critical metals and determine what research is needed to round out available data so that the substitute materials can be used with full confidence.

3. Document known substitution technologies and stockpile this information in a form that can be utilized immediately by industry and defense in an emergency. This is "Substitution Preparedness."
4. Identify basic research programs needed to create new options for substituting for these most critical metals and as this information is developed, add it to the substitution information stockpile. Avoid waiting for a crisis.
5. Structure research to have substitution as its only goal. Research priority would be determined on basis of probability of need, and probability of success. (This enhances substitution preparedness.)
6. Develop ways to improve awareness, interaction and communications in substitution technology through workshop/conferences as we are doing in this public workshop which includes representatives from government, industry and universities. Likewise, provide universities with information and encouragement needed to utilize more substitution and resource availability information in materials selection courses.
7. Emphasize research to utilize substitutes with wide distribution and with domestic and near domestic sources such as vanadium, molybdenum, tungsten and nickel. Expand research to develop manganese-aluminum alloy systems to substitute for chromium stainless steels on the basis of long term availability of manganese through ocean mining.

8. Recognize that the government has an important stake in replacements and that the nation as a whole and its security depend upon imports of critical metals. Realize that industry is involved in solving near term problems and has increasingly turned to application type work and that if government leaves the task of substitution research totally to industry it probably will not get done.
9. Accept the fact that the government has justification to assume leadership in supporting research to develop enhanced substitution and conservation potentials and in sponsoring work to gather, store and deliver reliable information on substitutes and conservation measures for critical materials in a form that can be applied immediately by defense and industry in an emergency cutoff.

Regarding the final point, although there are good reasons for individual business firms to underwrite work on substitutes for metals critical to their existence, I would like to comment on the rationale for government support.

An important consideration is to realize that the tendency is for industry not to address a critical supply situation until a material is unavailable and a crisis has developed. Then it's likely that before anything can be done the situation would be beyond the critical stage.

For example, as long as chromium is available and is relatively economical, as it is today, there's no incentive to substitute for it in heat treatable steels. But since substitution appears possible

in this instance, and we will hear more about this in the Workshop, it makes good sense to conduct research and "stockpile" information now on the production and heat treatment of chromium-free steels for production of important engineering components. The data could be drawn on immediately in a chromium emergency.

It should be noted that about 10% of chromium used annually in this country goes into two grades of constructional alloy steels, the 8600 series and the 4600 series. These steels are typically used to produce such things as gears and shafts. In this application, chromium is both highly effective and cost efficient.

However, technology can be developed through research to substitute other alloying elements for chromium. In an emergency this would release 10% of chromium for uses where substitution is not available, such as in jet engine alloys. This information would be equivalent to having 10% more chromium in the stockpile available for essential uses, and should be weighed against the cost of actually adding 10% more chromium to the strategic stockpile.

It should be noted that new tools are available today for studying substitution and interchangeability of alloying elements. Computer systems provide new approaches to the design of steels and alloys with specific properties for substitution applications and we will hear about these techniques in the Workshop Program.

Substitution is one important approach to meeting the challenges of strategic critical metals. There is, of course, an underlying need to understand and develop other options to survive any threatened metals cartel, including processing technology for high

performance, optimized use of material properties in design, net shapes, reinforced plastics, utilization of domestic resources, surface modified metals and reclamation.

Processing innovations will play a major role in advancing both substitution and conservation technology. For instance, high speed steels without cobalt utilizing increased quantities of molybdenum and tungsten are being produced by hot isostatic pressing (HIP) of powders, and we will hear about this in the Workshop Program.

Hot isostatic pressing will make increasingly important contributions to conservation by reducing the amount of strategic raw materials required to produce a component. Likewise, the process enables the optimum utilization of alloying elements in design.

Rapid solidification technology (RST) holds promise for the development of materials with higher performance as well as conservation of critical elements as we will hear in the Workshop. Some of the potentials that relate to critical materials, if this new technology can be moved forward, are exciting:

1. Cobaltfree, high creep strength, nickel base superalloys for turbine airfoils.
2. An appreciable increase in incipient melting point of nickel base superalloys.
3. Oxidation/corrosion resistant iron-aluminum alloys and perhaps manganese-aluminum alloys as substitutes for chromium stainless steels.
5. Laser glazing to produce layers with different alloy compositions.

It also should be noted that RST promises to improve aluminum and titanium alloys as well as superalloys as we will hear in the Workshop.

Earlier it was noted that research efforts should be aimed at developing materials technologies to utilize to the fullest extent domestic and near domestic metal resources. (Incidentally, it appears that the Soviets are giving much consideration to this.) A workshop session is being devoted to these more available resources including molybdenum, nickel, vanadium and tungsten. Likewise, consideration is being given to titanium supply and improved utilization of what's available.

Also as I indicated earlier, manganese is of interest in the long term as a resource in alloy systems utilizing aluminum to substitute for chromium stainless steels. The long term potential for abundant supplies of manganese from ocean mining of nodules suggests research support for alloy designers in this area. The Workshop Program will explore future directions for manganese alloy research. In April 1978, Metal Progress published the article "An Austenitic Stainless Steel Without Nickel and Chromium" which stirred up a lot of interest. The author of this article is with us for a workshop presentation. In the current May issue of Metal Progress, an article along similar lines points out that the replacement of nickel by manganese and chromium by aluminum yields a Fe-Mn-Al alloy that is ideal for cryogenic applications.

Enhanced activity is being generated in conservation of strategic elements by recycling and reclamation of critical metals. This workshop will focus on a new process for reclamation of critical metals back to quality of the virgin metals.

Application of existing and developing technology for metallurgical coating systems offers a great potential to save critical metals. In fact, in developing the Workshop Program I arrived at the feeling that an entire workshop could be devoted to opportunities for conservation utilizing surface modification technologies.

I will touch briefly on some of these technologies which will be considered. Hard facing as a method of effective wear and corrosion control is receiving increasing attention to impart essential surface properties with minimum use of chromium and cobalt. A tremendous potential exists for design of hard facing into fabrication of original equipment in a conscientious effort to conserve critical metals and make components last longer.

Likewise, designing with available clad steels and other clad materials can economize on critical materials compared to use of solid high alloy products. Clad materials properly applied can provide all the advantages of a solid critical alloy composition.

Surface modified metals offer many possible substitutes in applications requiring solid alloys containing strategic metals like chromium and cobalt. Several techniques are available or are in the development stage including ion implantation, laser and electron beam high rate fusion, spraying and surface coating with ceramics.

The concept behind surface modification is basically to put the properties of the critical metal where they are required rather than making the entire component from a critical metal alloy. New techniques are available for surface alloying as we will hear. High rate surface fusion provides rapid solidification rates which give

valuable surface properties. Ion implantation with chromium or cobalt provides the basis metal with greater corrosion and wear resistance. Design goals can be achieved with implanted ions.

In the future we will see more composite metal components in addition to polymer based composites which we will consider specifically in the workshop.

We hope this workshop will stimulate the business sector to take a more active role in dealing with the realities of critical metals. This includes the establishment of vigorous materials management policies and programs that cover availability, conservation, substitution, reclamation and the minimal use of critical strategic materials.

Critical material requirements should be considered in new product and process developments and in long term planning. Specific technical responses should include research in cooperation with customers and suppliers which focuses on systems based on available metals and alloys with only small additions of critical materials. Also, work should be pushed to enhance the mechanical properties of less critical alloys in an effort to meet performance requirements for alloys containing strategic elements as well as to explore the use of advanced materials and coating systems which will displace or reduce the over-all need for critical metals.

Finally, it is most important that this type of information on critical materials issues be discussed openly at all levels of the company and especially at corporate levels where the discipline of assignments can be established.

As I said earlier this is a "technology" workshop with the message that technology can provide answers (some say the best answers) for reducing this country's vulnerability to the potential of cutoff of supplies of critical metals.

An important reality, however, is that technology cannot provide quick fixes in most cases. It takes time and considerable investment to develop, quantify and establish designer confidence in a new material or even a modified alloy. These observations were among those made by Dr. Arden Bement, a participant in the workshop, in a talk "Strategic Minerals - A Resource Crisis" before the New York Chamber of Commerce and Industry and Council on Economics and National Security.

However, Dr. Bement went on to conclude, "An overriding reality is that technological solutions will come much faster than the political and social solutions necessary for the peaceful international sharing of the finite resources of our planet."

One final note which helps to emphasize the objectives we have set for the workshop comes from an address I heard in New York about two weeks ago. The occasion was the annual meeting of the American Iron and Steel Institute and the speaker was Eugene A. March, Group Vice President, Colt Crucible Industries Inc., on the subject, "Needed: A National Strategic Metals Policy."

Mr. March stated: "The severity of the critical materials problem is such that we must tackle it on both fronts: Decrease demand to the extent we can through substitution and conservation, and increase the supply to the extent we can through exploration, research and the astute practice of international politics."

I believe we will all agree that this workshop will provide a better understanding and point out future directions for study and action on one of the fronts deemed so important by Mr. March.

Let me say that in behalf of the sponsors, the U. S. Department of Commerce/National Bureau of Standards and the U. S. Department of the Interior/Bureau of Mines, we sincerely appreciate your participation in this important program to provide input to the materials policy direction as well as point out future directions for study and actions.

As I indicated earlier, Dr. Wachtman will talk about this and I am sure we will all look forward to Mr. Milbergs' comments on "Developing a Policy Framework on Materials Issues" at the workshop dinner.

TECHNICAL ACTIVITIES AT THE NATIONAL BUREAU OF STANDARDS
RELATED TO SUBSTITUTION AND CONSERVATION

J. B. Wachtman
Center for Materials Science

Technical Activities at the National Bureau of Standards
Related to Substitution and Conservation

Workshop on Conservation and Substitution Technology
for Critical Materials

Vanderbilt University
June 17, 1981

John B. Wachtman, Jr.
Director, Center for Materials Science
National Bureau of Standards

The Center for Materials Science carries out a comprehensive materials research program of about \$23 million per year including about \$8 million per year received from other Federal agencies for technical support of their programs.

Slide 1 (P2-5). This work relates to processing, properties, and durability of engineering materials. In addition, it addresses nondestructive evaluation throughout the processing and use of engineering materials. I cannot possibly give a complete overview in fifteen minutes, but I would like to give you a feeling for the character of our program and some examples of work relating to substitution for critical materials or conservation of critical materials.

Slide 2 (P2-6). Our overall program has an impact on critical materials in two principal ways. First, it assists in the development of new, advanced materials which can displace critical materials in some applications. Second, it assists in the conservation of conventional materials through helping to reduce processing losses, improve design, and extend lifetime.

Slide 3 (P2-7). The special character of our work is its orientation toward measurement technology, accurate data, and physical models needed for effective utilization of materials. Let me give an example of our work in each of these three areas.

Slide 4 (P2-8). In the area of measurement technology we are developing improved measurement methods to assist in safe, but not excessively conservative design with structure, containers, etc., involving alloys containing critical materials. Shown here is a procedure for measuring the value of the J-integral, a measure of toughness useful in design based on elastic-plastic fracture mechanics. Current work here is focused on pipeline steels, pressure vessel steels, ship steels, and steels for cryogenic applications.

Slide 5 (P2-8). In the area of data, we measure and provide many types. Also, we operate a number of data centers which evaluate data from the literature and in some cases provide calculated estimates. One which is important to development of substitute alloys is the Alloy Phase Diagram Center operated in conjunction with the American Society for Metals.

Slide 6 (P2-10). We are currently editing ASM's quarterly, Bulletin of Alloy Phase Diagrams, and developing computer programs to aid in evaluation, plotting, and display of diagrams. Shown here is a display of one section of the iron-chromium-nickel diagram.

Slide 7 (P2-11). Turning to the area of basic understanding, expressed in the form of models to support development of improved materials or improved use of materials, consider this example of a fracture map for silicon carbide which is a candidate material for replacing superalloys at high temperatures in some applications. This map, built up by piecing together individual theories and experiments shows that five different types of mechanical behavior take place in different regions of the space of temperature and stress intensity factor.

Slide 8 (P2-12). Additional examples of materials substitution or displacement can depend on advances in processing or advances in reliability. Let us take one example from metals, polymeric composites, and ceramics.

Slide 9 (P2-13). We are going to hear a good deal later in this meeting about the potential of rapidly solidified alloys to replace critical materials in some applications. The properties of rapidly solidified alloys depend on the special structures and microstructures which can be developed. We are attempting to improve conventional theory and check it by experiment to trace out regions of concentration and velocity favoring particular microstructures. Hopefully, this will have predictive power and aid in production of improved materials.

Slide 10 (P2-14). Organic-matrix composites are also a very promising material for greater use and we are going to hear more about them later in the Workshop. Problems with delamination, especially during impact loading do exist. One approach to reduce this problem through the use of rubber-modified epoxy resins is under study in our laboratory and at the Naval Research Laboratory. In these materials the rubber is present as tiny particle inclusions in the epoxy matrix. Slide 11 (P2-15). A localized stress-relief zone is produced which blunts cracks and flaws in the material. Slide 12 (P2-16). Fracture energy values have been measured on the original resin (205) and the rubber-modified resin (F-185). These show large increases in fracture energy both for the neat resin and in composites.

Slide 13 (P2-17). Concerning the field of ceramics as substitutes, I have already mentioned silicon carbide and a fracture map representation of its different regions of mechanical behavior. Different types of safe-life design methodology can be used for these regions. Here is a design diagram for regions of slow crack propagation. Using the method summarized by this diagram, a minimum safe life can be assured for each combination of proof stress and operating stress.

Slide 14 (2-18). Many uses of critical materials as alloying elements are to enhance the corrosion-, fracture-, or wear-resistance of engineering materials. We have work on conservation by increasing durability of all these types while using less critical materials. Let us take one example concerning corrosion and two examples concerning wear.

Slide 15 (P2-19). A new, low-noise instrument developed at NBS allows one to measure the frequency spectrum of microvolt level fluctuations in voltage which we have found to correlate well with localized corrosion; i.e., pitting. Here are results on a new alloy $\text{Fe}_{32}\text{Ni}_{36}\text{Cr}_{14}\text{P}_{12}\text{B}_6$ produced by rapid solidification. When in crystalline form localized corrosion occurs

unless an applied voltage is raised to a critical level. The same composition, when quenched to a glassy form, does not undergo localized corrosion even under conditions causing localized corrosion in crystalline material.

Slide 16 (P2-20). Here are results showing how nickel-phosphorus coatings on 0.2 tool steel can be varied to give much lower wear rates than either uncoated tool steel or a conventional coating. The lowest rate of dry sliding wear is produced by an electroless coating technique but this is a relatively expensive procedure. Conventional electroplating produces a relatively soft coating. By careful adjustment of the electroplating conditions a very hard, wear-resistant coating can be produced. It is particularly interesting to notice that pulsed electroplating gives a harder coating than conventional direct current electroplating, both in the as-plated and heat-treated conditions.

Slide 17 (P2-21). Our final example concerns another aspect of wear resistance. There are two-phase alloys with a hard carbide phase. For certain conditions of dry abrasive wear, the alloys with coarse carbides are much more wear resistant at the same hardness value of the alloy.

NBS MATERIALS SCIENCE

- Processing Science
- Non-Destructive Evaluation
- Structure Properties Science
- Durability Science

NBS PROGRAM IMPACT IN CRITICAL MATERIALS

Measurement and Science Base for:

- Development of Advanced Materials
- Conservation of Conventional Materials

NBS PROGRAM OUTPUT

- Measurement Technology
- Essential Data
- Basic Understanding

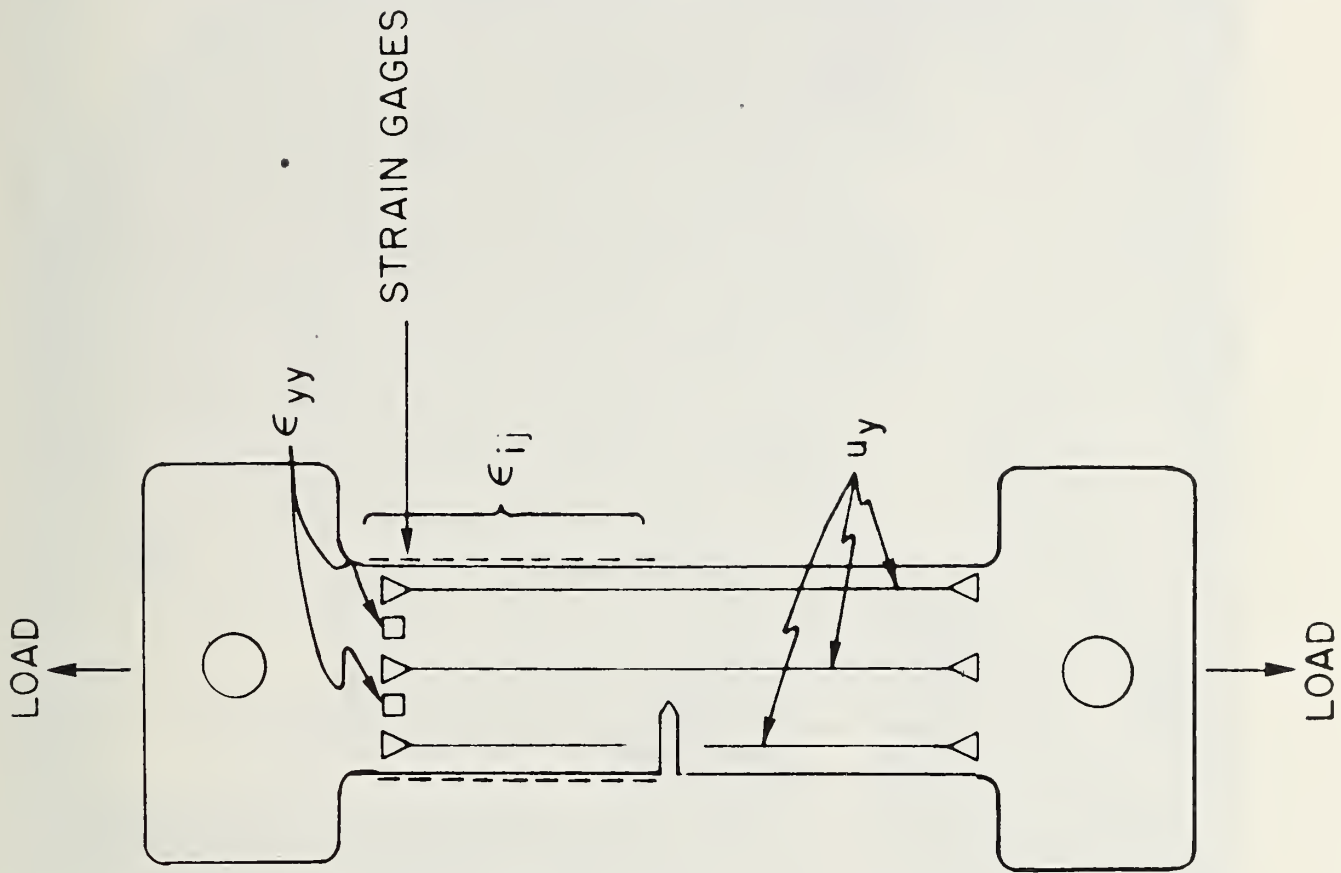

$$J = \int_r w dy - \bar{T} \cdot \frac{\partial \bar{u}}{\partial x} dx$$

$$W = \int_0^\epsilon \sigma_{ij} d\epsilon_{ij}$$

$$\bar{T} = E \epsilon_{yy} \hat{y}$$

$$\bar{u} = \text{LVDT displacement}$$

NBS MATERIALS DATA CENTERS

- Diffusion Data for Metallic Alloys
- Critically Evaluated, Computerized Alloy Phase Diagrams
- Phase Diagrams for Ceramics Processors and Users



SILICON CARBIDE (NC 203) IN AIR

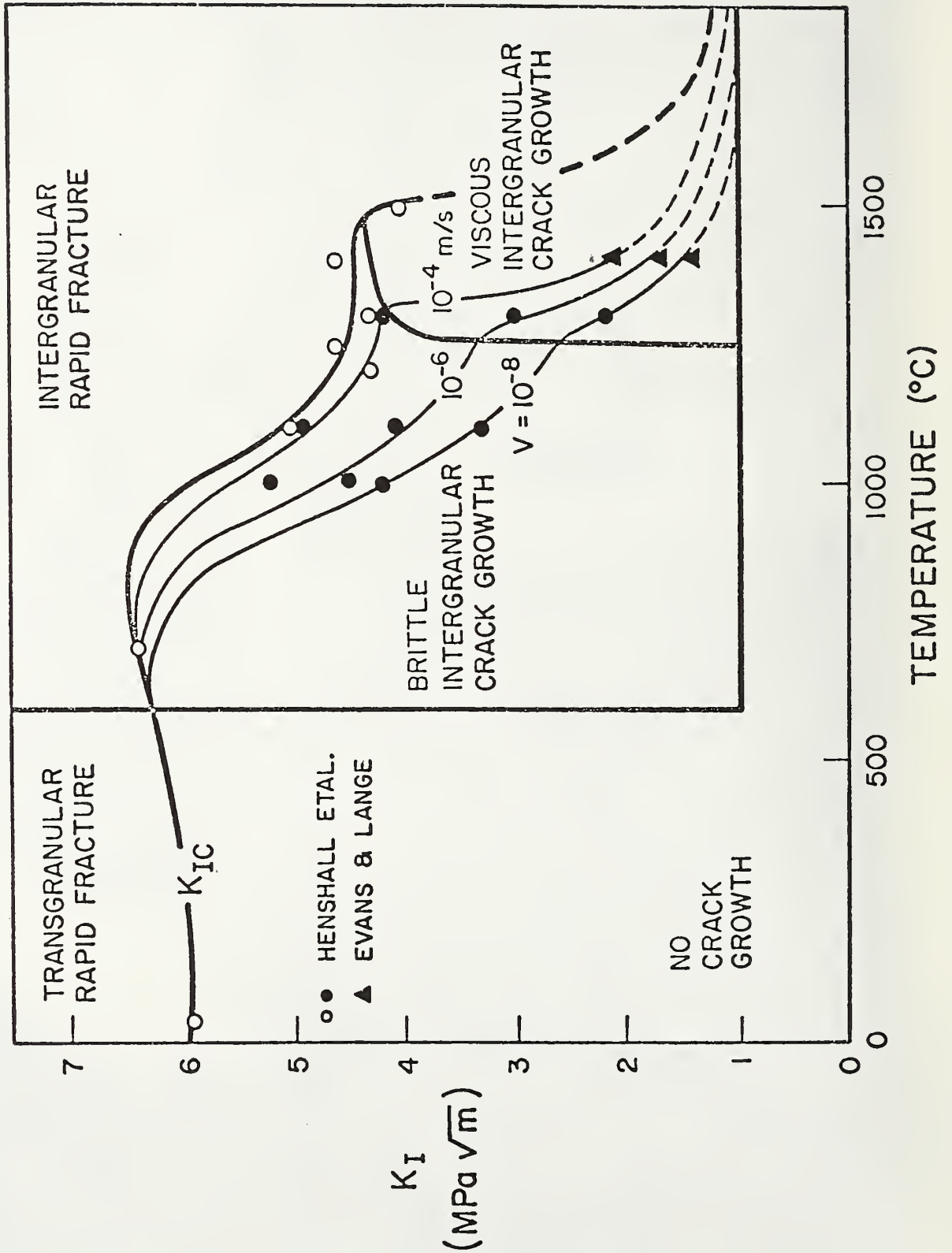

MATERIALS SUBSTITUTION & DISPLACEMENT

- Metals
- Organic Composites
- Ceramics

EFFECTS OF RAPID SOLIDIFICATION ON ALLOY HOMOGENEITY

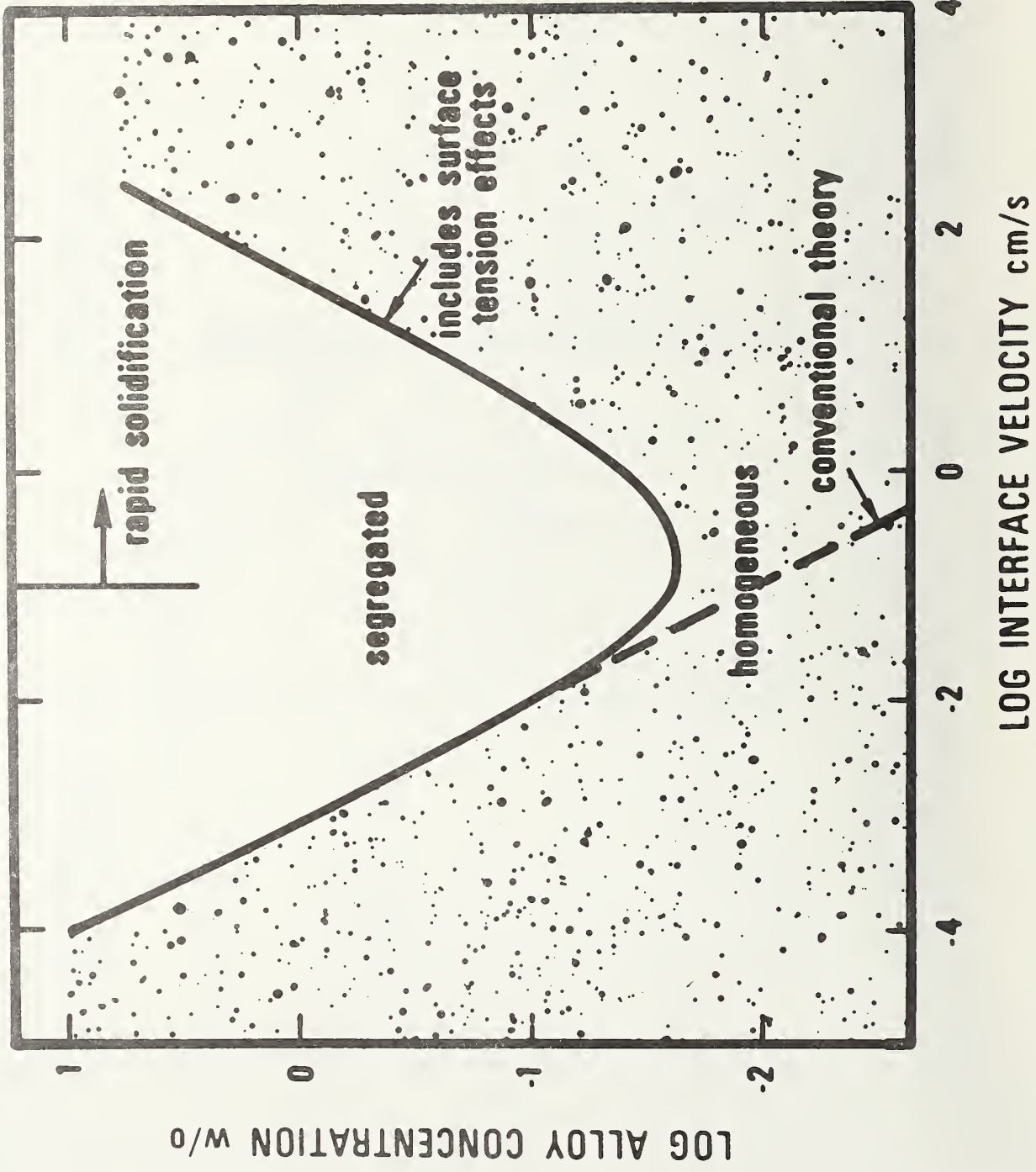

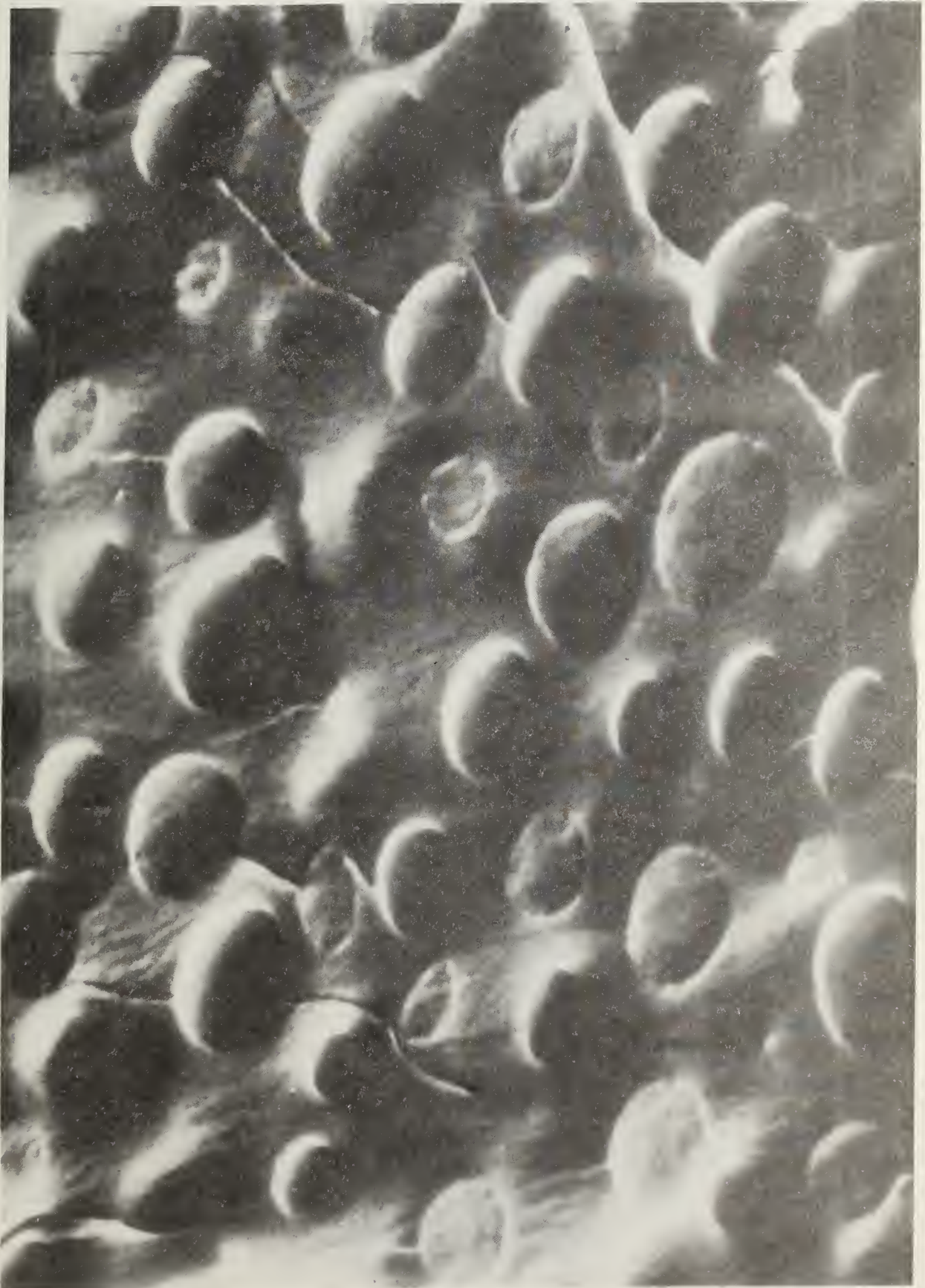



FRACTURE ENERGY

G_{Ic} , kJ/M²

MODULUS
GPa

FIBER VOL
%

MATERIAL

NEAT RESIN
0.27
5.1

2.8
2.2

0
0

205 RESIN
F-185 RESIN

INTERLAMINAR

1.0
4.4

31.6
24.0

59.9
59.7

205/GLASS CLOTH
F-185/GLASS CLOTH

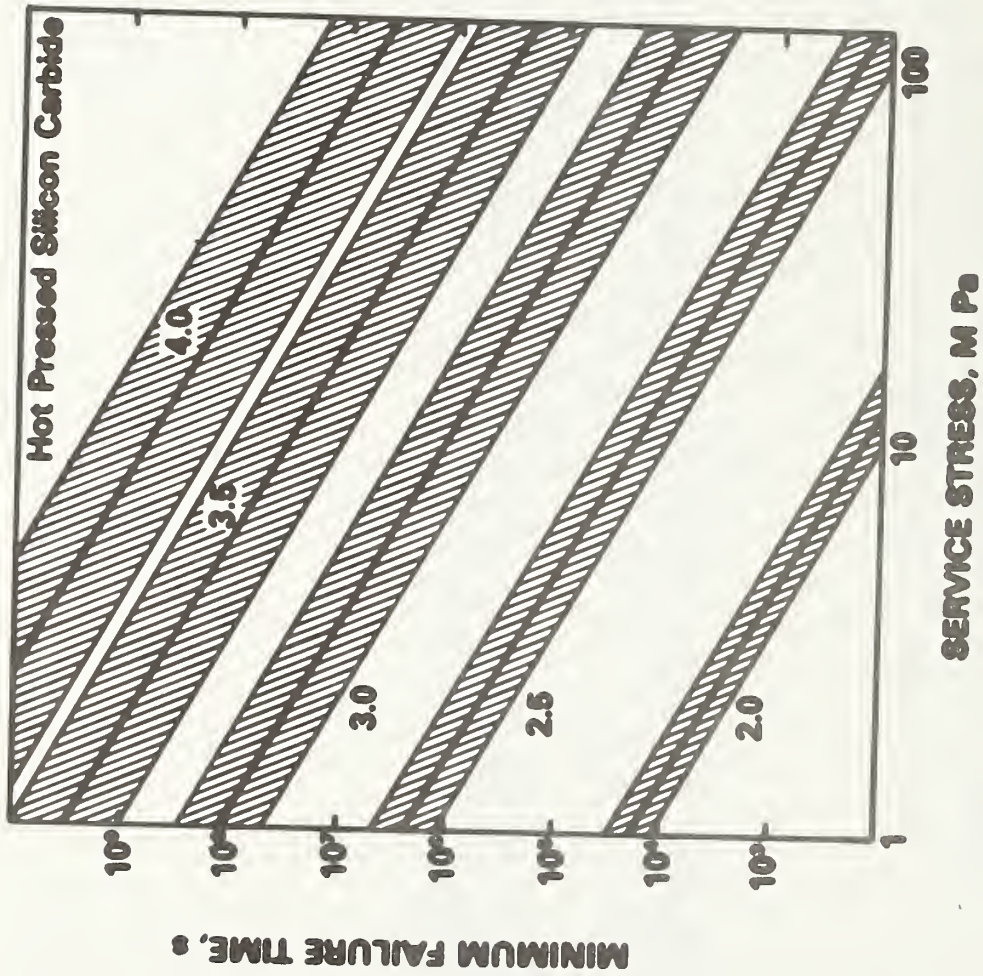
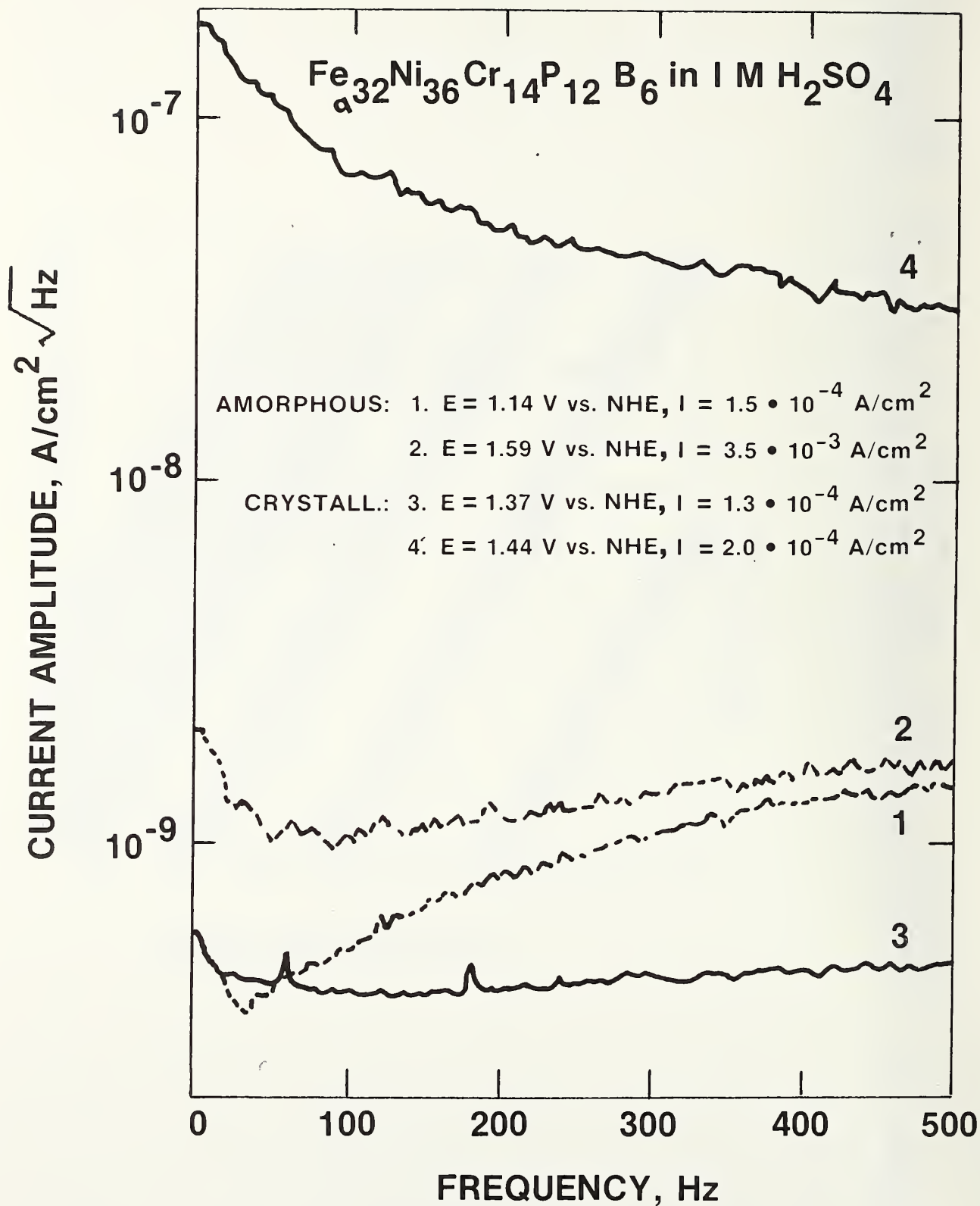

Figure 18. Design diagram based on proof testing: silicon carbide, 1400°C (Wiederhorn et al, ref. 95).

MATERIALS CONSERVATION

Corrosion	}	Metals
Fracture		Ceramics
Wear		Polymers



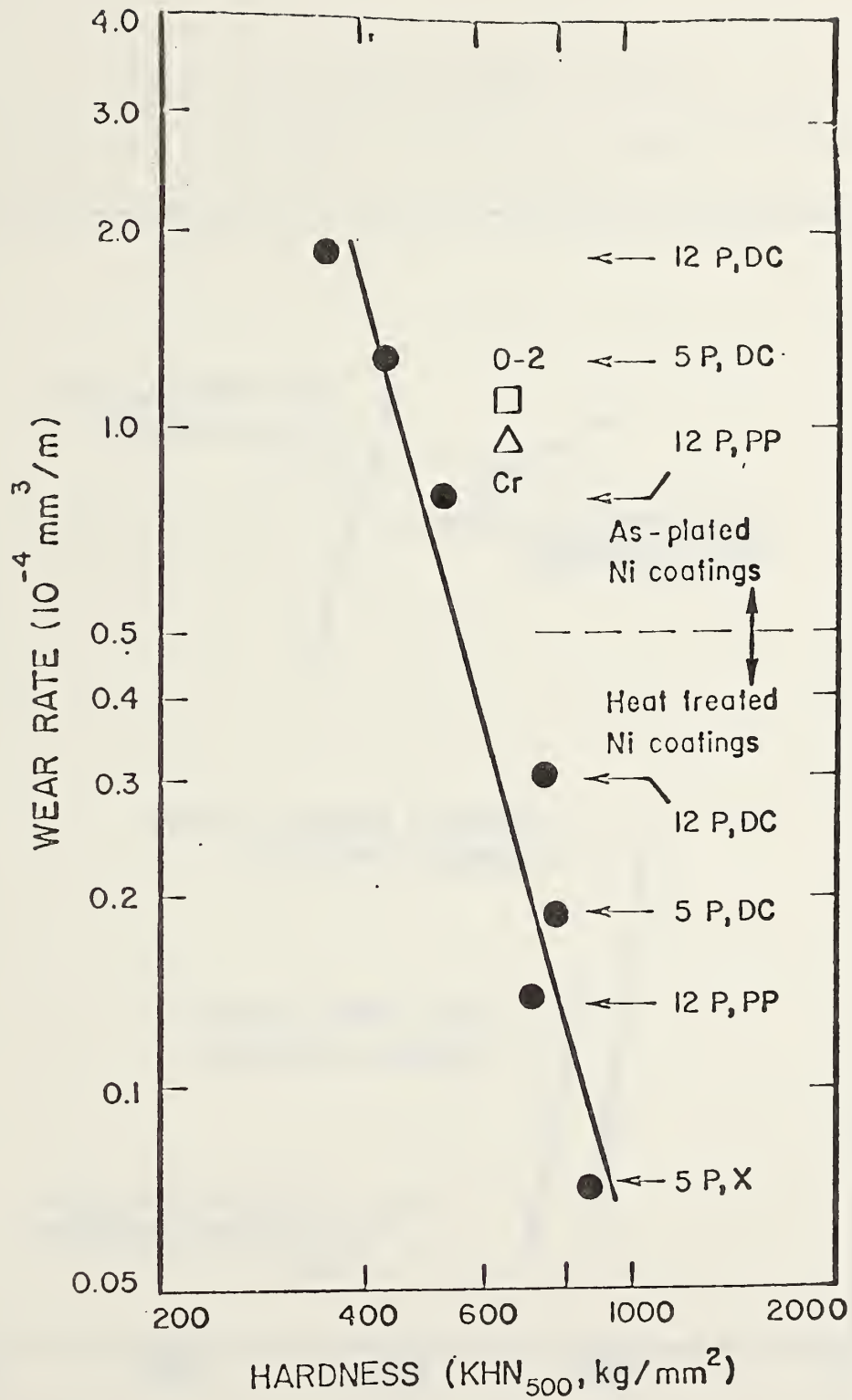
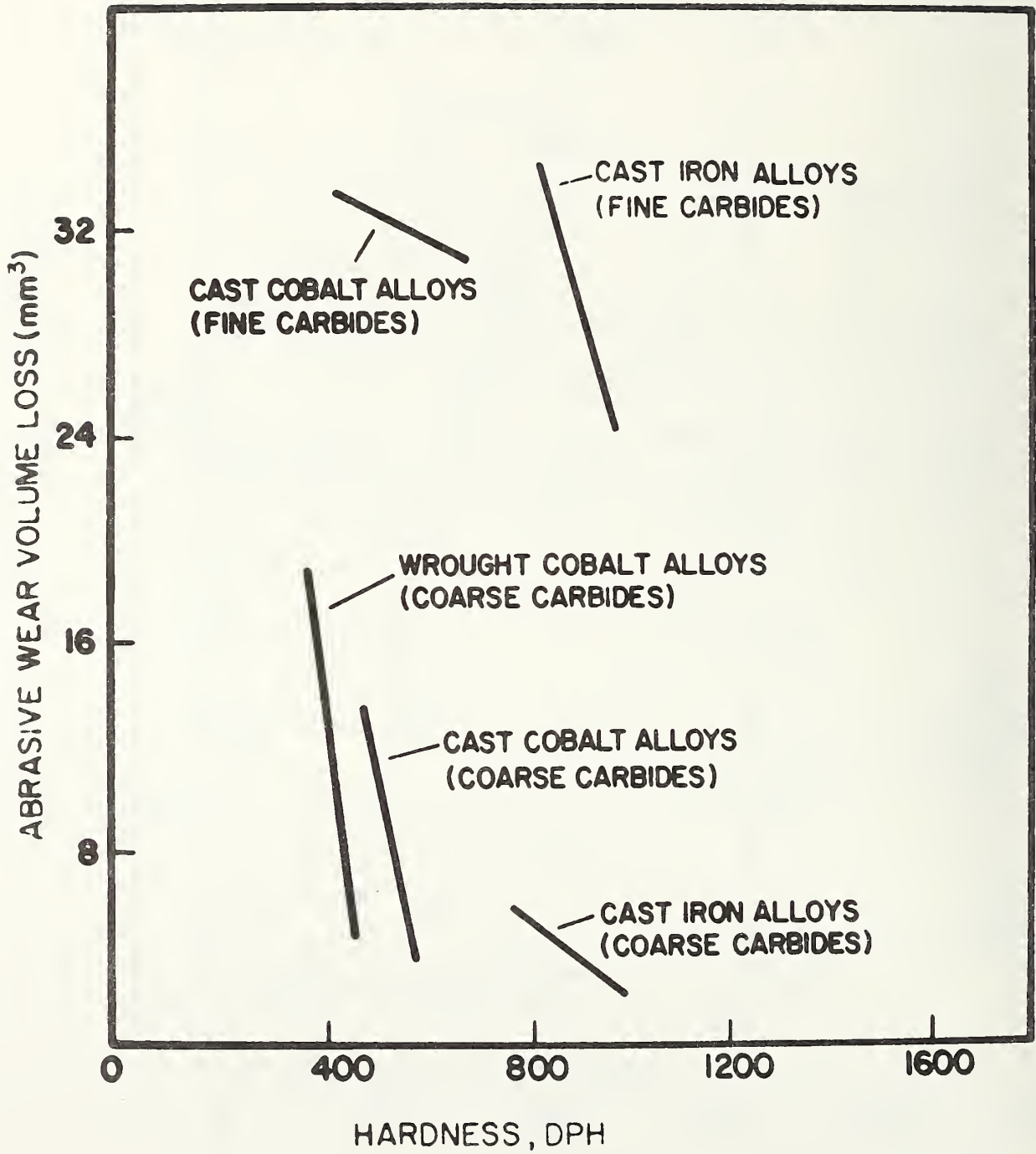

Fig. 14. Observed relation between wear rate (mm^3/m) and Knoop hardness (kg/mm^2) for the coatings studied. For the Ni-P coatings, the wear rate shows a dependence on $H^{-3.6}$.



CURRENT ACTIVITIES IN SUBSTITUTION
UNITED STATES DEPARTMENT OF INTERIOR, BUREAU OF MINES

Ralph C. Kirby
Minerals Resources Technology Division

CURRENT ACTIVITIES IN SUBSTITUTION

UNITED STATES DEPARTMENT OF THE INTERIOR
BUREAU OF MINES

Ralph C. Kirby
Director
Mineral Resources Technology Division

Presented at
Workshop on
Conservation and Substitution Technology
for Critical Materials

June 15-17, 1981
at
Vanderbilt University
Nashville, Tennessee

For seven decades the Bureau of Mines of the Department of the Interior has been the Federal Government's primary agency for research in minerals and mineral raw materials. Its mission, Figure 1, is to help ensure the continued viability of the domestic minerals and materials economy, and to help ensure the maintenance of an adequate minerals base for the United States.

The fundamental program for minerals and materials R&D resides in the Mineral Resources Technology program. It is aimed at anticipating and providing solutions to the technological aspects of national minerals problems; helping to ensure the availability of the critical and strategic mineral resources upon which our industrial economy is built. The program, Figure 2, should help:

- * provide technology for an adequate supply of minerals for the United States,
- * for conserving and making the best use of what we have,
- * and if we need it and don't have it, doing something to get it.

The Mineral Resources Technology program addresses the functions that span the entire Bureau of Mines portion of the mineral cycle except land rehabilitation, as shown in Figure 3. One usually associates the Bureau's R&D efforts with mineral supply problems or the raw materials end of the mineral cycle. However, the Bureau has made many contributions to materials development, and to materials recycling.

Although this conference is on conservation and substitution for critical materials, the Bureau of Mines uses a broader definition of substitution that includes the substitution of one resource for another. In certain cases some resources can serve as substitutes or alternatives for others. The substitution of nonmagnetic taconites for the "direct-shipping" iron ores is one example.

In the late 1950's, the Bureau's analysis of the domestic iron ore situation, Figure 4, suggested that technology to process non-magnetic taconites would be more than desirable in 15 or so years. Bear in mind, of course, the import picture suggested then does not obtain now. In fact, in 1980, we imported only 22% of our iron ore needs. But to help solve the predicted problem, we started pioneering work to concentrate fine-grained hematites in 1957.

As the high-quality "direct-shipping" iron ore was depleted from the great iron ranges of Michigan and Minnesota, magnetic separation technology to enrich the lower-grade magnetic ores was developed.

However, vast tonnages of nonmagnetic ores lay untouched and worthless. In the laboratory, and then in the pilot plant shown in Figure 5, the Bureau of Mines developed the technology to recover the nonmagnetic ore. The problem was that, when the ore was ground finely enough to liberate the iron, too much iron was rejected with the waste. We developed technology to selectively flocculate or clump the fine particles of iron together so that they would not be carried away with the waste.

Based on the patents that resulted from Bureau research and on cooperative development, the Tilden plant started production in 1974 at a capital cost of \$200 million, employing 600 people. Through the array of 150 flotation cells shown in Figure 6, each with 500 cubic foot capacity, passed material that made 4 million tons of iron ore pellets per year. The capacity of the plant has since been doubled to produce 8 million tons of pellets from 20 million tons of ore--about 10% of U.S. iron ore output.

Between 1957 and 1970, the Bureau spent about \$2 million for research on the jasperite ores of upper Michigan. Staff analysis reports the value to the economy of the period 1972-1980 was approximately \$1.5 billion.

The elements of the Mineral Resources Technology program (Figure 7) cover both materials supply and materials utilization. This program is concerned with mining more efficiently, extracting more in processing plants, and converting domestic mineral resources to reserves. It addresses two national problems of major concern: the technology needed for an adequate supply of minerals and materials, and the need to improve productivity.

This year, this program is funded at roughly \$26 million, Figure 8, with the largest part going to the sub-program on Mineral Science and Technology. The budget proposed by the previous Administration allowed a 6.8% increase for inflation. The program itself had an increase of \$4.365 million, of which \$900,000 of this was mandated for energy conservation steps at two research centers. The remaining \$3.465 million is distributed as follows (Figure 9):

- * \$1 million is requested to support basic research in minerals crushing and grinding, fine particle processing fundamentals, and thermodynamic and kinetic aspects of cobalt reactions.

- * \$2 million is requested for new materials for energy development

- Research to develop materials that provide adequate, not best, performance with a minimum of critical metals in composition

- Research that will lead to materials adequate for the mining and processing of new domestic energy resources and that can reduce critical materials needs in the equipment and facilities used in the nonfuel minerals industry, particularly for mining and processing equipment.

- * \$0.465 million is requested for solvent extraction and ion exchange of cobalt and to reassess low-grade onshore manganese resources.

In recent weeks the media (Figure 10) has picked up the warning from business and government leaders regarding our heavy dependence on imported strategic minerals. We propose to increase our effort on this important national problem.

But, it should be pointed out that of the 19 materials listed as critical by the Council on International Economic Policy in 1974, Figure 11, the Mineral Resources Technology program is presently conducting research on all but two--mercury and natural rubber. And we've worked on improved mercury processing in the recent past.

Specific proposals for research on critical minerals have resulted from reprogramming of funds by Secretary Watt from the Minerals Environmental Technology Program. This reprogramming (Figure 12) reflects the new Administration's emphasis on Strategic and Critical Minerals and reflects instructions in PL 96-479 (National Materials and Minerals Policy, Research and Development Act of 1980) to "...increase the level of mining and metallurgical research by Bureau of Mines in critical and strategic minerals."

In essence, President Reagan's revision of the 1982 budget proposes a 50% increase for the Mineral Resources Technology Program. Critical and strategic minerals research is distributed among all three subprograms, Figure 13.

Advancing Mineral Science and Technology is the largest subprogram, and includes basic research and all extraction technologies. It covers a broad portion of the technological innovation spectrum--from concept to pilot plant. The following are examples of some of the research on critical materials conducted under this subprogram.

The United States depends on imports for most of its cobalt and nickel supply. However, about 10% of our nickel is smelted as ferronickel from one

deposit in Oregon. There are numerous other nickel-cobalt laterite deposits in southern Oregon and northern California of somewhat lower grade, Figure 14.

Using a novel Bureau-developed process (Figure 15) to treat these laterites, we not only recover nickel in an environmentally acceptable way, but we also recover cobalt as well. The laterite deposits also contain 2% chromium; we are developing the technology for recovering it from the residues after the nickel and cobalt have been leached. The new technology is being perfected in a contract pilot plant in Tucson, Arizona, operated for us by UOP, Inc. (Figure 16).

The largest known cobalt reserve in the United States is in the Blackbird Mountain area of Idaho. It could supply as much as 20% of our cobalt needs for 15 years. Although the deposit has been previously worked, production ceased because of severe metallurgical problems. To help solve these problems, we are working on leaching-electrowinning techniques to recover the cobalt. Copper, present in the ore is also recovered. The ore is leached under pressure to put the cobalt into solution, without releasing arsenic to the environment. Once in solution the metallic copper and cobalt can be extracted by electrowinning (Figure 17).

The sub-program titled Conserving Domestic Mineral Resources is designed to help conserve and make the best use of those mineral resources that we have. It is aimed at getting all mineral values from domestic resources, and at making use of bypassed ore bodies that were initially uneconomical to recover. Recycling is also a major part of this subprogram. The following three projects illustrate the scope of our recycling program with respect to critical materials such as chromium. Our research efforts cover the chemical, metallurgical, and refractories aspects of chromium recycling.

Chromic acid etching solutions are used for brass finishing, etching of printed circuits, anodizing, and preparation of plastics for plating. The solutions are discarded when the etching rate becomes too slow due to chemical reduction of chromic ions and/or contamination of the solution. The Bureau system, (Figure 18), regenerates the solution by electrochemically oxidizing the chromium ions and removing contaminants. Three industrial plants have tested the unit. One has already constructed their own unit. A fourth company is in the process of constructing their own unit.

Research has developed technology to recycle stainless steelmaking particulate wastes such as electric furnace dust, mill scale, grinding swarf, and AOD dust. The waste dusts are pelletized with a small quantity of portland cement before introduction into the furnace. Ten tons of pelletized waste are being introduced into the stainless and specialty steelmaking furnace, Figure 19, to determine melting conditions.

Furnace operations such as shown in Figure 19, require refractories, most of them containing some chromite. The Bureau is investigating methods to recover chromium-bearing refractory grains from used furnace refractories, Figure 20, and reusing them.

A major element of the last of our three subprograms, Developing Domestic Mineral Resources, focusses on both alternative mineral resources and substitute materials.

Searles Lake, California, is a large desert lake in San Bernardino County about 150 miles northeast of Los Angeles. It contains very dilute dissolved tungsten, about 55 ppm in highest concentration. The large volume of lake brine makes Searles Lake a significant resource in relation to current U.S. tungsten reserves. Searles Lake brines are too dilute to process alone for tungsten, but

it could be recovered as a byproduct during commercial processing that produces potassium salts, soda ash, salt cake, and boron chemicals. We are working cooperatively on a cost-sharing basis with the Kerr-McGee Chemical Corporation, which operates the plant.

The key step in the recovery technology is an ion-exchange resin that the Bureau developed specifically for these brines. When the equipment (Figure 21) is scaled up to process the full 1,800 gal/min feed stream of the West end plant, tungsten recovery will be equivalent to about 2 percent of current U.S. consumption. Additional tungsten from the larger Argus plant could increase that figure to 7%.

The shaded area of Figure 22 shows the relative portion of Aluminum raw material, that is bauxite and alumina, that we import. Looking at this another way, the United States builds some of the most technologically advanced military hardware in the world, such as the F-14 fighter plane shown in Figure 23-A. The airframe of the F-14 is made primarily of aluminum. Where other specific material properties are required, steel, titanium, and boron composites are used. Only about 7%--just barely the equivalent of the vertical stabilizers--of the airframe is built from home grown alumina and bauxite (compare the shaded areas of Figures 23-B and 23-C).

To reduce our dependence on imported bauxite as a source of alumina, we are obtaining process technology information from our small pilot or miniplant (Figure 24) in Boulder City, Nevada. Here, a variety of processes for recovering alumina from domestic nonbauxitic resources, such as clay and coal wastes, are being tested. Five alumina-producing companies (Figure 25) are joined with the Bureau in this work on a cooperative, cost-sharing basis.

Improved fabrication methods can reduce the quantity of raw materials needed. About 14,000 lbs. of critical materials are needed to build the engine shown in Figure 26. The fly-away or final weight of the engine is only about 3,000 lbs. The difference is what is lost in the manufacturing processes and machining of parts. For example, a forged titanium hub for a helicopter rotor blade weighs about 1,000 lbs. before machining and 150 lbs. after. The buy-to-fly ratio is about 6.6 to 1. Sikorsky Aircraft Division of United Technologies Corporation believes that through manufacturing research on casting technology the buy-to-fly ratio can be reduced to better than 2:1.

Powder metallurgy technology is another way to reduce the buy-to-fly ratio. Powder can be pressed into most any shape desired, Figure 27. It can then be sintered to make it a single coherent part. There is minimal waste this way from machining, because after sintering the part has nearly its final shape.

The main thrust of our powder metallurgy effort is directed toward obtaining high purity reactive metal powders. Powder metallurgy components of titanium and titanium alloys could be possible substitutes for nickel-and cobalt-based superalloys in low temperature applications. These superalloys are critical to national defense, and yet nickel and cobalt ores are largely imported, whereas the titanium ore, ilmenite, is domestically abundant. Titanium could substitute for some superalloys if titanium powders could be made free of chloride and tungsten impurities, which significantly affect weldability.

Bureau research has shown zinc is a possible substitute for lead-tin and for silver solders in certain applications. More important, however, is the ability of zinc solders to fill a temperature gap, Figure 28, between the melting point of silver solder and the melting point of lead-tin solders. The Bureau's zinc soldering system works well with both aluminum and copper. When

aluminum heat exchangers such as shown in Figure 29 fail in service they are generally discarded as scrap. Old field repair techniques opened more seams than they repaired on aluminum units. The new soldering system makes it possible to repair these units, extending service life. In addition, the higher melting points of the zinc solders permit radiators, Figure 29, to be operated at higher temperatures. Therefore, they can be made smaller, using less metal, and engine efficiency is improved.

Corrosion-resistant steels can be made by substituting elements such as aluminum and molybdenum for the critical material chromium. Figure 30 shows the corrosion resistance of one of the new chromium-free alloys as compared to that of ordinary low carbon steel. Both were oxidized for the same time at 750°C. The new Fe-8Al-6Mo-0.8Zr-0.1C alloy steel is a potential substitute for stainless steels containing critical materials in some applications.

Outreach to industrial, academic and other governmental sectors involved with conservation and substitution of critical materials to obtain input for programming decisions is an important and continuing part of management of the Mineral Resources Technology program. Many of our projects, such as those listed in Figure 31 are done in cooperation with members of the industrial sector. Communication with members of the minerals industry is important to our program. The input is an important segment of our program planning.

BUREAU OF MINES **MISSION**

ENSURE THE CONTINUED VIABILITY OF THE DOMESTIC MINERALS AND MATERIALS ECONOMY AND THE MAINTENANCE OF AN ADEQUATE MINERALS BASE, SO THAT THE NATION'S ECONOMIC, SOCIAL, STRATEGIC AND ENVIRONMENTAL NEEDS CAN BE BETTER SERVED

Figure 1. Mission of the Bureau of Mines of the U.S. Department of the Interior

MINERAL RESOURCES TECHNOLOGY PROGRAM

- **PROVIDES TECHNOLOGY WHICH CAN MAINTAIN AN ADEQUATE SUPPLY OF MINERALS FOR THE UNITED STATES**
- **PROVIDES TECHNOLOGY WHICH CAN ENCOURAGE CONSERVATION AND BEST USE OF DOMESTIC MINERAL SOURCES**
- **PROVIDES TECHNOLOGY WHICH CAN EXTEND THE LIFE SPAN OF DOMESTIC MINERAL RESERVES AND ENCOURAGE SUBSTITUTION OF ABUNDANT MINERALS FOR THOSE WHICH MUST BE IMPORTED**

Figure 2. Mineral Resources Technology Program

BUREAU OF MINES ROLE IN THE MINERAL CYCLE

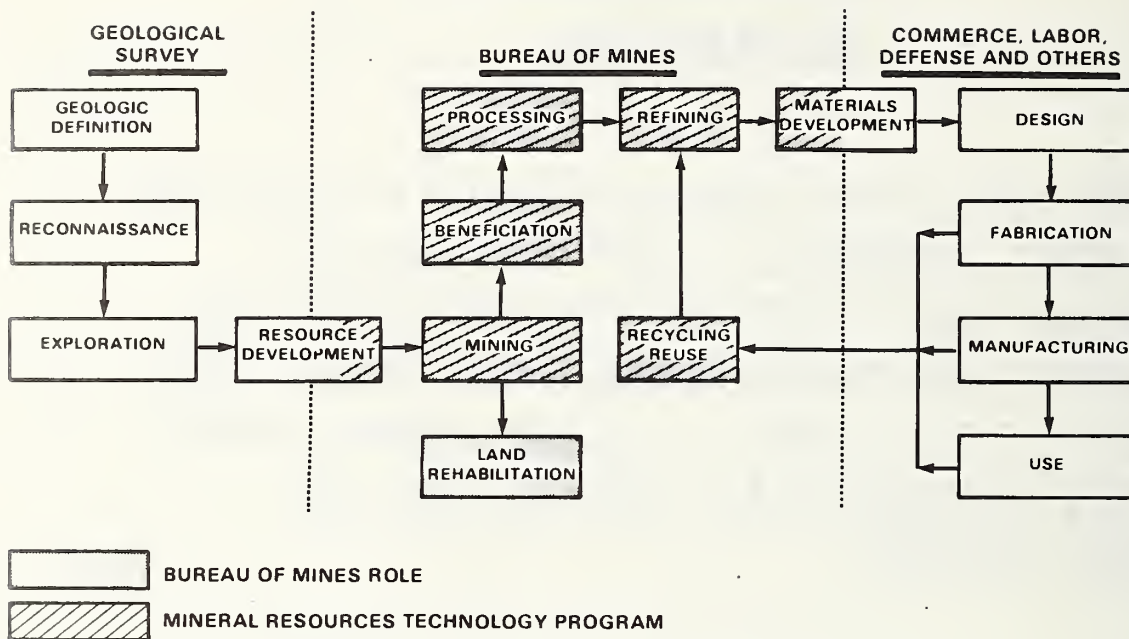

Figure 3. Mineral Cycle Showing Bureau of Mines and Mineral Resources Technology Program Roles

DOMESTIC IRON SUPPLY/DEMAND TO YEAR 2000

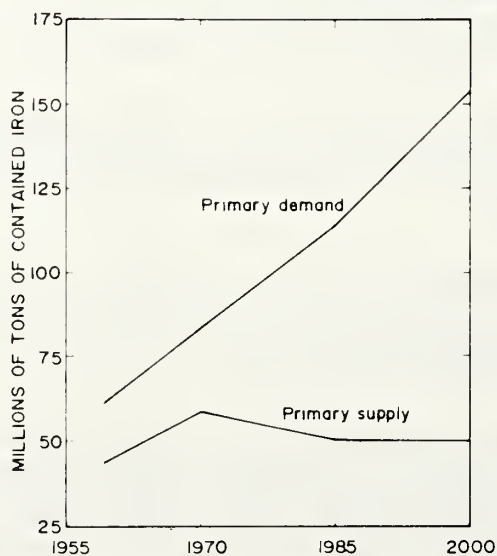

Figure 4. Bureau Analysis of Domestic Iron Ore Situation (1955-2000)

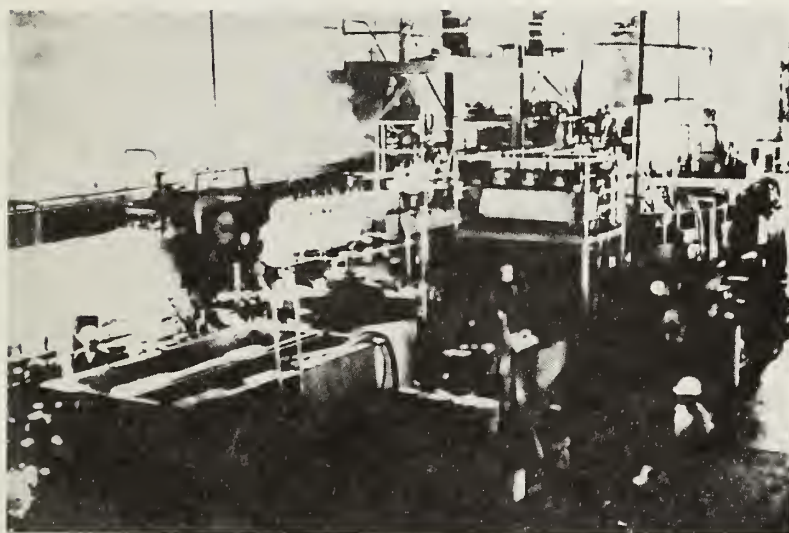

Figure 5. Bureau of Mines Pilot Plant to Recover Nonmagnetic Ore

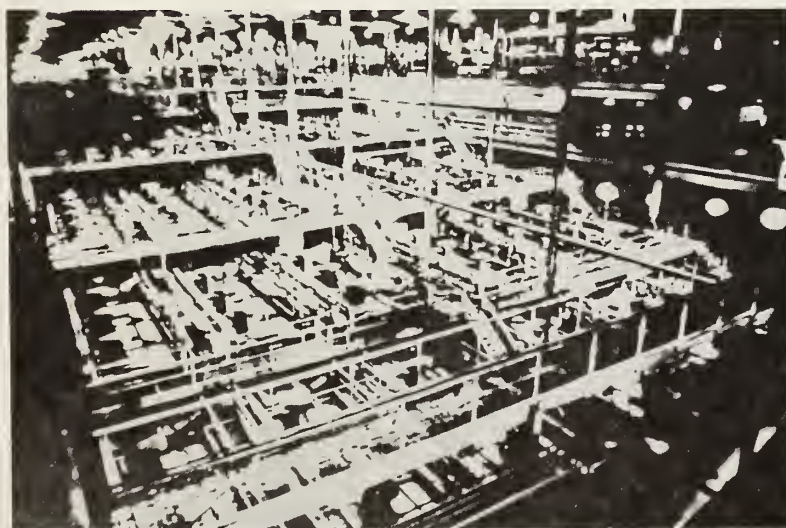

Figure 6. Bureau of Mines Research and Cooperative Development at Work at Tilden Plant

MINERAL RESOURCES TECHNOLOGY

- **Advancing Mineral Science and Technology**
 - Mineral Science Base
 - Efficient Extraction Technology
- **Conserving Domestic Mineral Resources**
 - Maximum Resource Recovery
 - Scrap and Waste Utilization
- **Developing Domestic Mineral Resources**
 - Use of Plentiful Resources
 - Substitutes for Critical and Strategic Minerals

Figure 7. Elements of Mineral Resources Technology Program

FY 82 BUDGET ESTIMATES (\$000)

	FY 81	FY 82		
		Current	Change	Enhanced
Advancing Mineral Sci. and Technology	\$14,143	\$15,021	{ + \$1,000 + 900 }	\$16,921
Conserving Domestic Mineral Resources	5,885	6,283	–	6,283
Developing Domestic Mineral Resources	6,192	6,656	{ + 2,000 + 465 }	9,121
	\$26,190	\$27,960	\$4,365	\$32,325

Figure 8. Mineral Resources Technology 1982 Program Funding

- **Basic Research, \$1.0 Million**
 - **Crushing and Grinding**
 - **Fine Particle Processing**
 - **Cobalt Chemistry**
- **Materials, \$2.0 Million**
 - **Wear- and Corrosion-Resistant Materials**
 - **Erosion/Abrasion-Resistant Materials**
 - **High-Temperature, High-Pressure Equipment**
- **Extractive Technology, \$0.465 Million**
 - **Solvent Extraction of Cobalt**
 - **Reassess Technology for Manganese Recovery from Low-Grade Onshore Resources**

Figure 9. Distribution of Proposed Increases in FY 1982 Budget

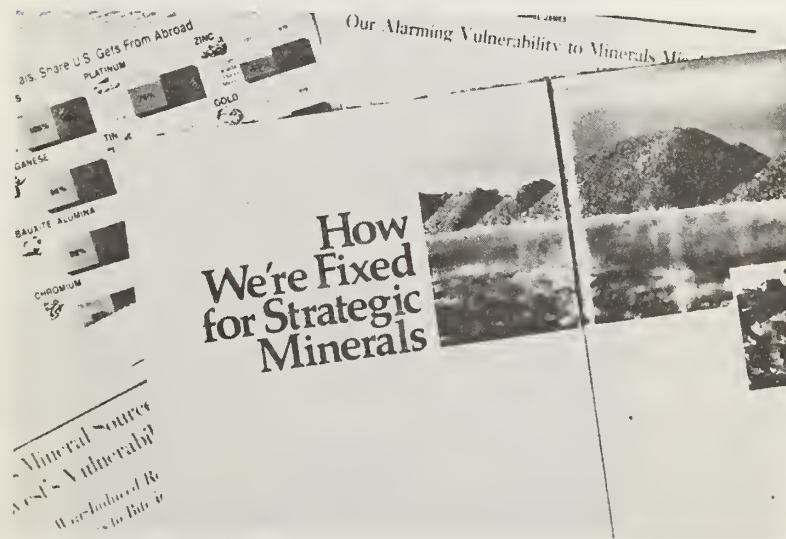

Figure 10. Media Focus on U.S. Dependence on Imported Strategic Minerals

CRITICAL MATERIALS

U.S. Council on International Economic Policy, 1974

- Aluminum
- Chromium
- Platinum
- Iron Ore
- Nickel
- Natural Rubber
- Manganese
- Zinc
- Tin
- Titanium
- Cobalt
- Mercury
- Tungsten
- Lead
- Columbium
- Vanadium
- Fluorspar
- Copper
- Phosphate

Figure 11. Critical Materials Determined by Council on International Economic Policy (19174)

REPROGRAMMING (\$000)

PL 96-479: "...increase the level of mining and metallurgical research by Bureau of Mines in critical and strategic minerals..."

● Increase, \$8,600

— Chromium	\$2,550	— Physical Chemistry	\$1,000
— Cobalt	1,450	— Mining	500
— Manganese	750	— Particulate Mineralogy	500
— Titanium	700	— Process Water	400
— Zinc	250	— Scrap	300
— Tin	200		

Figure 12. Reagan Administration Budget Reprogramming Reflects Public Law 96-479, National Materials and Minerals Policy, Research and Development Act of 1980

FY 82 BUDGET REVISIONS (\$000)

	REQUEST PENDING	PROPOSED AMENDMENT	REVISED REQUEST
Advancing Mineral Sci. and Technology	\$16,921	+ \$4,100	\$21,021
Conserving Domestic Mineral Resources	6,283	+ 1,700	7,983
Developing Domestic Mineral Resources	9,121	+ 2,800	11,921
	<u>\$32,325</u>	<u>\$ 8,600</u>	<u>\$40,925</u>

Figure 13. Distribution of FY 1982 Budget Revisions Among Mineral Resources Technology Subprograms

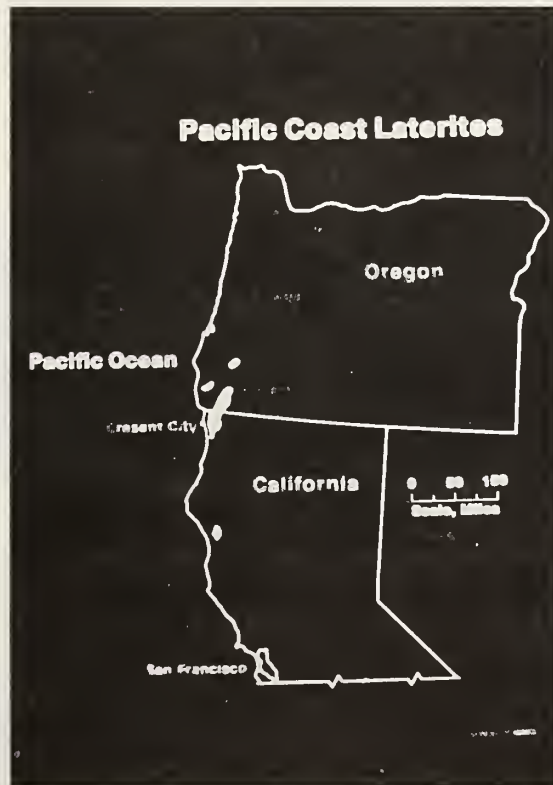

Figure 14. Nickel-Cobalt Laterite Deposits in Southern Oregon and Northern California

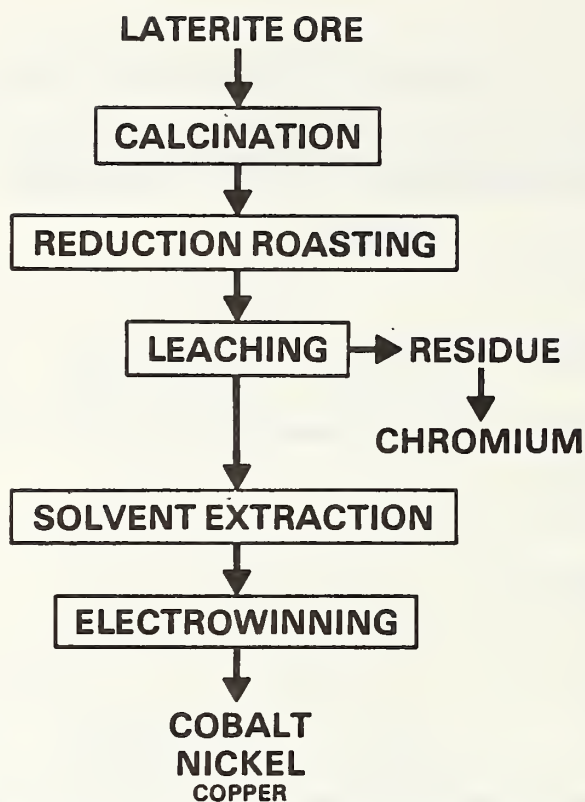

Figure 15. Bureau-Developed Process for Treating Laterites Recovers Nickel as Well as Cobalt

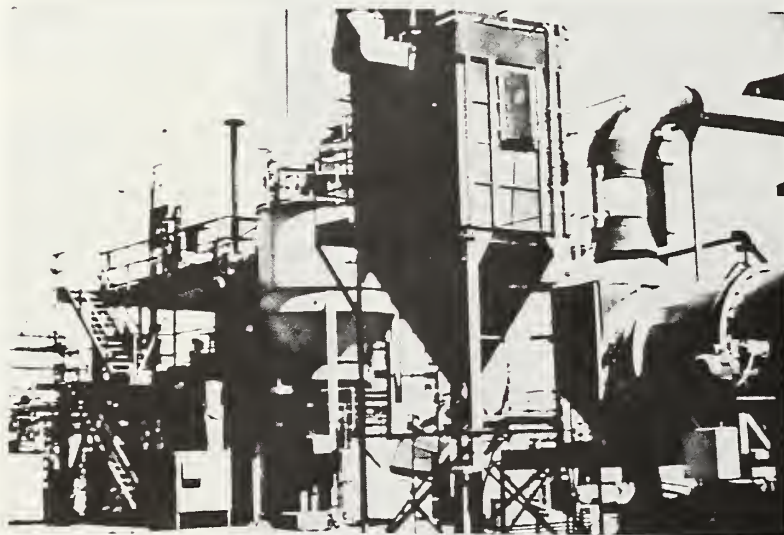

Figure 16. Pilot Plant for Recovering Nickel and Cobalt is Operated by UOP, Inc.



Figure 17. Extraction of Metallic Copper and Cobalt by Electrowinning

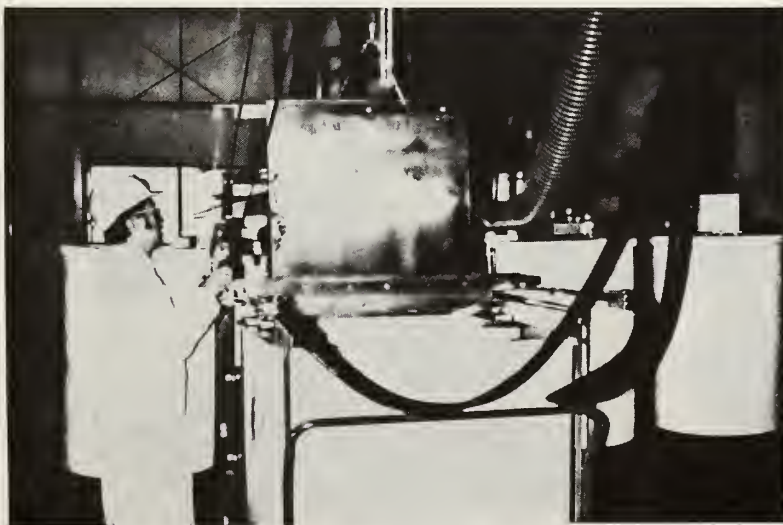

Figure 18. Bureau System for Regenerating Acid Etching Solutions by Electrochemically Oxidizing Chromium Ions and Removing Contaminants

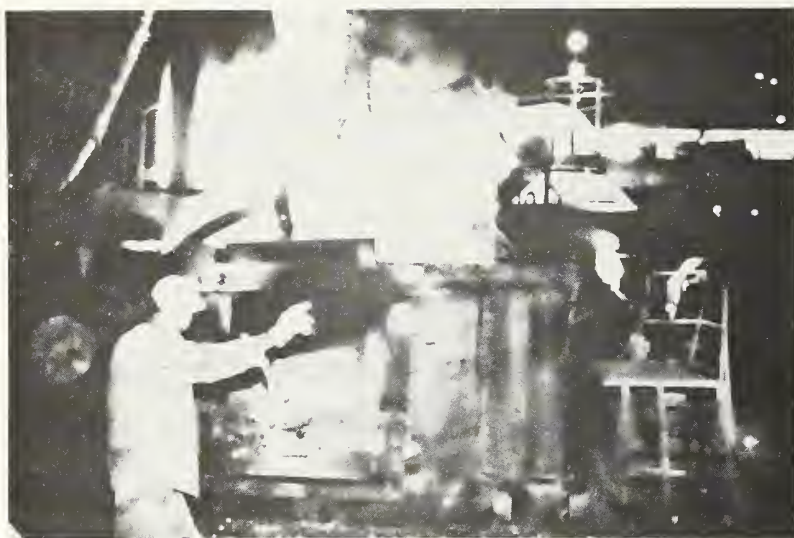

Figure 19. Steelmaking Furnace Used to Determine Melting Conditions of Pelletized Stainless Steelmaking Waste Dusts



Figure 20. Bureau Effort to Recover Chromium-Bearing Refractory Grains From Used Furnace Refractories for Reuse

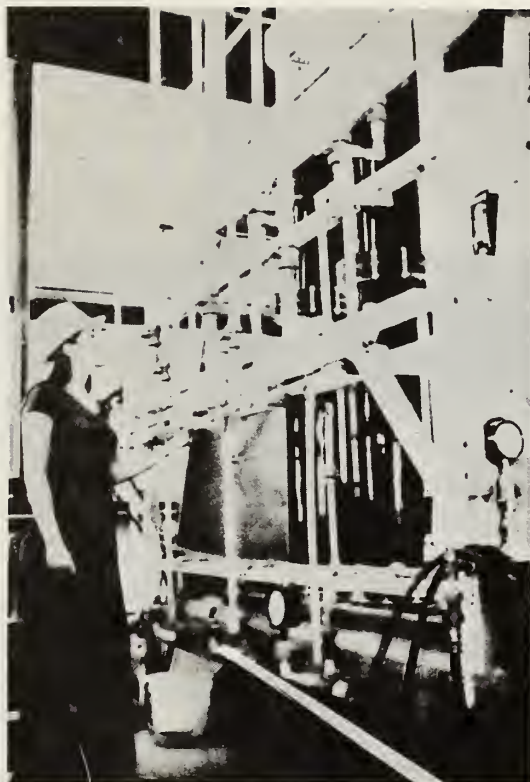

Figure 21. Equipment Used to Recover Tungsten from Searles Lake Brines
Key to this effort is the Bureau-developed ion-exchange resin.

U.S. SOURCES AND USES OF ALUMINUM

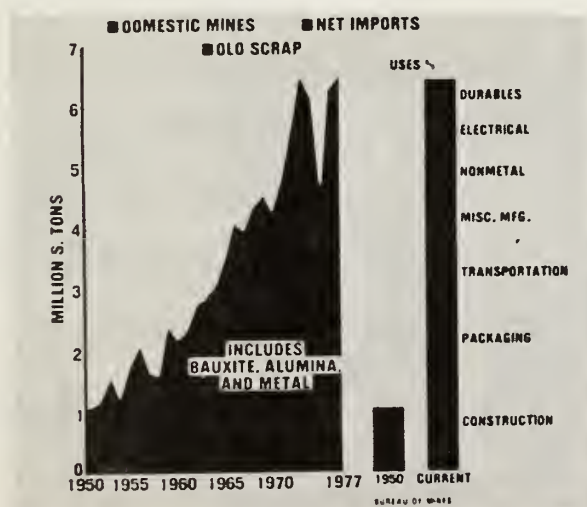

Figure 22. U.S. Sources and Uses of Aluminum



Figure 23-A. F-14 Fighter Plane

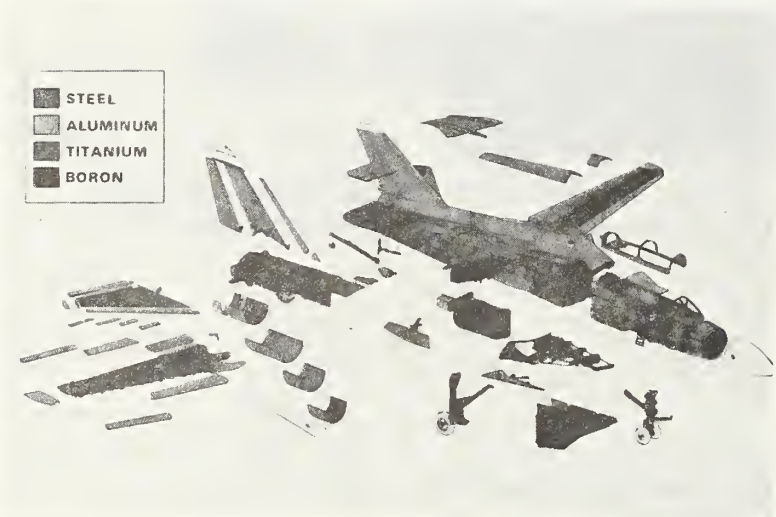

Figure 23-B.
F-14 Airframe With Critical
Materials Composition Shown

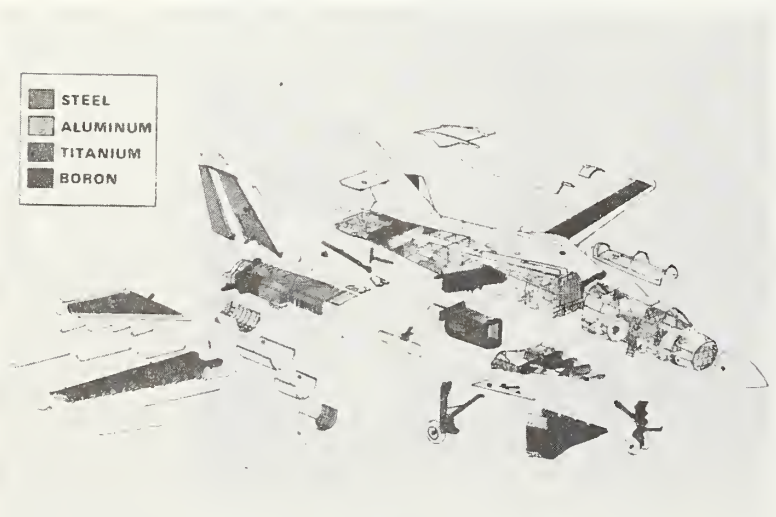

Figure 23-C.
F-14 Showing Home Grown
(Domestic) Alumina and
Bauxite Composition

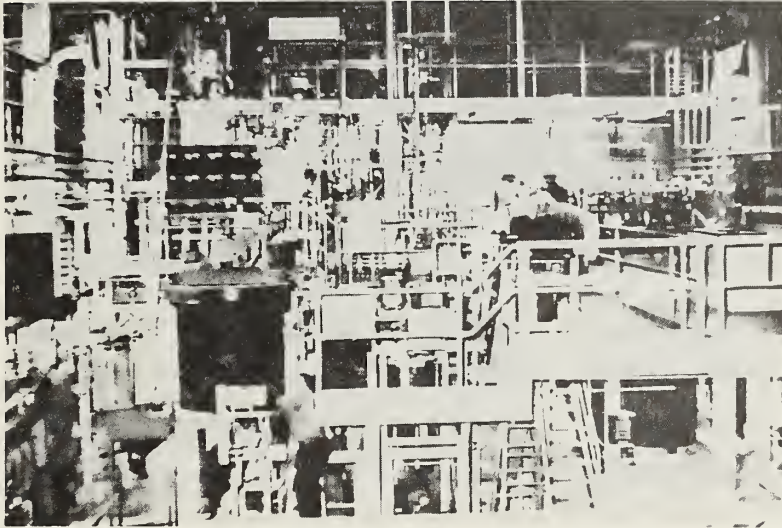
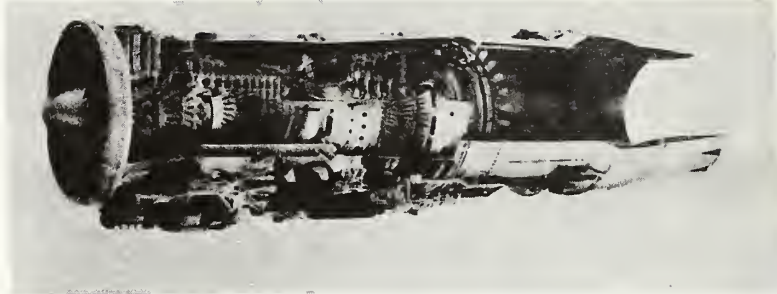

Figure 24. Alumina Miniplant in Boulder City, Nevada

PARTICIPANTS IN ALUMINA MINIPLANT PROJECT

**ALUMINUM COMPANY OF CANADA, LTD.
ANACONDA ALUMINUM
BILLITON INTERNATIONAL METALS
KAISER ALUMINUM AND CHEMICAL CORP.
REYNOLDS METALS COMPANY**

Figure 25. Industry Cooperators in Bureau Alumina Effort



TITANIUM	5,366 LB	NICKEL	5,204 LB
CHROMIUM	1,656 LB	COBALT	910 LB
ALUMINUM	720 LB	COLUMBIUM	171 LB
TANTALUM	3 LB		

Figure 26. Weight of Critical Materials Needed to Build 3,000-lb. Engine



Figure 27. Powder Metallurgy Technology Yields Powder That Can be Pressed Into Most Shapes

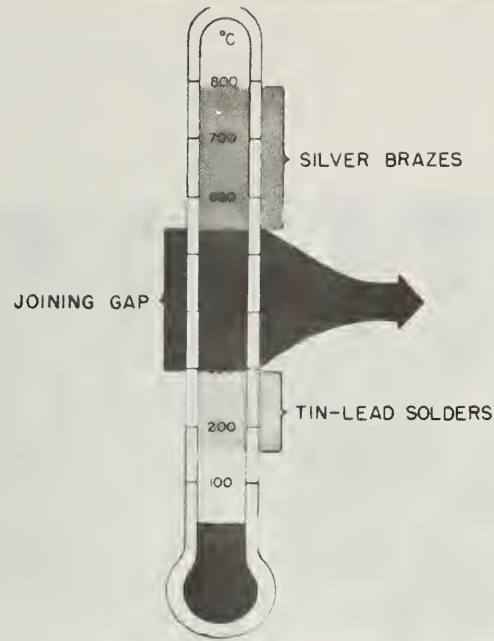

SOLDER/BRAZE JOINING GAP

Rolla Research Center

Figure 28. Solder/Braze Joining Gap

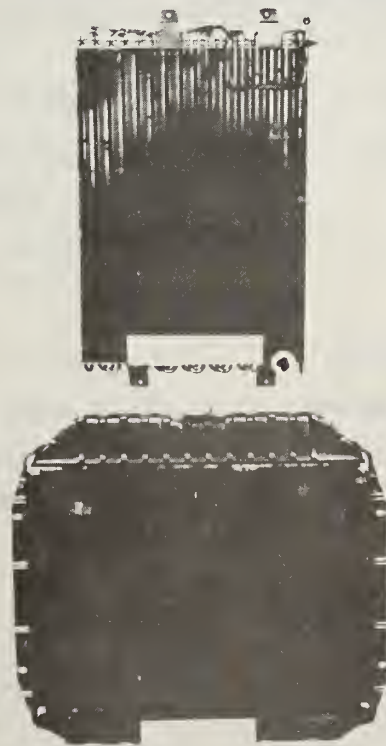

Figure 29. New Soldering System Permits Repairs to Aluminum Units, Extends Service Life



Figure 30. Corrosion Resistance of New Chromium-Free Alloy Compared to That of Ordinary Low Carbon Steel

INDUSTRIAL COOPERATION

Raise Hoist Lead Project Iron Ore Phosphate	Homestake Mining Co. 4 Lead Producers MIFGA, AISI TFI, Florida Inst. of Phosphate Res.
Retractable Bit Borehole Mining Chromic Acid	Longyear Co. Mobil, Agrico Bell Helicopter, Keeler Brass
Recycling	NARI, AFS
Tungsten Sulfur Concrete Alumina Miniplant Corrosion Critical Materials	Kerr-McGee ASARCO, The Sulphur Inst. 5 Alumina Producers Natl. Assn. Corrosion Engrs. ASM

Figure 31. Industrial Cooperators to Bureau of Mines Projects

NASA'S ACTIVITIES IN CONSERVATION OF STRATEGIC AEROSPACE MATERIALS

Joseph R. Stephens
NASA-Lewis Research Center

NASA'S ACTIVITIES IN THE CONSERVATION OF STRATEGIC AEROSPACE MATERIALS

Joseph R. Stephens
Lewis Research Center

SUMMARY

NASA has several activities underway directed at conserving strategic materials used in the aerospace industry. Research efforts involving universities and industry as well as in-house activities at the NASA Lewis Research Center comprise the current COSAM effort - "Conservation of Strategic Aerospace Materials." The primary objective of COSAM is to help reduce the dependence of the United States aerospace industry on strategic metals, such as cobalt, columbium, tantalum, and chromium, by providing the materials technology needed to minimize the strategic metal content of critical aerospace components with prime emphasis on components for gas turbine engines. Thrusts in three technology areas are appropriate for COSAM. These include near-term activities in the area of strategic element substitution; intermediate-range activities in the area of materials processing; and long-term, high-risk activities in the area of "new classes" of high temperature metallic materials. This paper describes in some detail the efforts currently underway and initial results generated to date. Initial emphasis has been placed in the area of strategic element substitution. Specifically, the role of cobalt in nickel-base and cobalt-base superalloys vital to the aerospace industry is being examined in great detail by means of cooperative university-industry-government research efforts. Investigations are also underway in the area of "new classes" of alloys. Specifically, a study has been undertaken to investigate the mechanical and physical properties of intermetallics that will contain a minimum of the strategic metals. Current plans for COSAM also are presented in this paper.

INTRODUCTION

The United States is heavily reliant upon foreign sources for the supply of most strategic metals required by our aerospace industry. With the exception of molybdenum, iron, magnesium, and the rare earths, the United States imports from 50 to 100 percent of such aerospace metals Co, Cb, Ta, Cr, and Mn (ref.1). However, the potential for foreign cartels, political unrest, and production limitation is great and is intensified by steadily declining known reserves. Thus, the United States can expect to be faced with supply shortages and price escalation for many strategic metals. Since these metals are vital to the welfare of the nation's economy, their continued availability at a reasonable cost is a national issue which requires cooperative action between the aerospace industry and appropriate government agencies.

The aerospace industry is currently a major factor in the positive inflow of funds from U.S. exports (Ref. 2). This industry, and within it the aircraft engine industry in particular, relies heavily upon imports for several key strategic metals including cobalt, columbium, tantalum, and chromium. In order to offset or minimize future disruptions in supply, efforts to develop viable options must begin now, since a new material can take from 5 to 10 years of research and development efforts before qualifying for aerospace service.

NASA currently has plans to address the aerospace industry's needs to minimize the use of strategic metals for advanced aerospace systems. COSAM has as its broad objective the reduction of the dependence of the U.S. aerospace industry on strategic metals. This objective can be accomplished by providing the materials technology options needed to allow individual companies to trade-off the material properties of critical components versus cost and availability of their strategic metal content. This paper summarizes NASA's current activities in this area and broadly outlines the plans for COSAM.

STRATEGIC MATERIALS

A definition of strategic materials as used in this paper is given in figure 1. Strategic materials are those predominantly or wholly imported elements contained in the metallic alloys used in aerospace components which are essential to the strategic economical health of the U.S. aerospace industry. As the basis for what are considered strategic metals, we will focus on the aircraft engine industry's needs. Based on a survey of the ASME Gas Turbine Panel and a subsequent survey of a number of aerospace companies, the elements listed in figure 1 were considered to be the most strategic with respect to the aerospace industry. As a result of prioritizing by NASA's COSAM planning team supplemented by further discussions with several aircraft engine manufacturers, four elements emerged that were of particular concern. The alloys used to build the critical high temperature components for aircraft propulsion systems require the use of the four metals - cobalt, columbium, tantalum, and chromium. These metals are contained in steels, stainless steels, and superalloys that are used in engine manufacturing. Figure 2 lists these four elements in the high priority category with a brief rationale for this ranking. The remaining five strategic elements evolving from our surveys were given a lower priority and figure 2 also contains a short explanation for this ranking.

The location of these metals in aircraft engine compressors, turbines, and combustors is illustrated in figure 3. The need for such metals has increased as the demands have grown for higher durability plus high performance, fuel efficient aircraft turbine engines. Based on the essential nature of these metals and for the U.S. aircraft industry to maintain its competitive position, it is necessary that supplies be readily available at a reasonably stable cost. To achieve these requirements, domestic sources of key metals are desirable.

Today, we are almost totally dependent on foreign sources for these metals as shown in figure 4. In several of the countries listed in figure 4, recent political disturbances have led to supply interruptions. Therefore, the U.S. aircraft engine industry can be seen to be highly vulnerable to supply instabilities of the essential metals for engine manufacturing. Accompanying supply disruptions or increased demand is an accelerated price increase. Escalated prices during the recent few years are evident for tantalum, columbium, cobalt, and to a lesser degree for chromium, as shown in figure 5. These rapid price increases illustrate the additional vulnerability of the U.S. aircraft engine industry to cost fluctuations. The essential nature of cobalt, columbium, tantalum, and chromium along with their vulnerability to supply instabilities and cost fluctuations combine to cause these metals to be classified as strategic aerospace metals.

The portion of these four metals used in superalloys for the aerospace industry compared to all other U.S. uses is shown in figures 6 through 9. The use of these metals in superalloys as compared to total U.S. consumption in 1979 was: cobalt - 30 percent, columbium - 28 percent, tantalum - 5 percent, and chromium - 3.4 percent. These data reveal that superalloys comprise the largest single use of both cobalt and columbium.

OVERVIEW OF COSAM

COSAM has as its primary objective the reduction of the dependence of the U.S. aerospace industry on strategic metals. COSAM can also provide the industry with some options for making their own property versus availability/cost trade-offs when selecting aerospace alloys. These objectives will be achieved by providing the technology needed to minimize the strategic metal content of critical components in aerospace structures. Initial emphasis will be placed on the aircraft engine industry. COSAM initially is focused on conservation of the strategic metals cobalt, columbium, tantalum, and chromium. Strategic metals such as titanium, the precious metals, tungsten, and others may be brought into COSAM as it progresses.

Along with prioritizing the strategic elements that were identified, the role that the NASA's COSAM effort should encompass was also evaluated. Options that were considered are listed in figure 10. All of these options could contribute to the conservation of strategic materials and minimization of U.S. aerospace industry vulnerability. However, within the scope of our program a decision was reached based on LeRC traditional roles and expertise to focus on the three areas noted in figure 10. These areas consist of strategic element substitution, process technology, and alternate materials. Contributions to the other areas may benefit from COSAM through cooperative programs with other governmental agencies such as in the area of scrap reclamation or through cooperation with technical societies in establishing a critical material index. Having selected a list of four high priority strategic elements and having defined the areas of emphasis for COSAM and specific objectives, a technology approach was adopted as shown in figure 11. Conservation, as well as reduced dependence on strategic metals, will be achieved in the

area of strategic element substitution by systematically examining the effects of replacing cobalt, columbium, and tantalum with less strategic elements in current, high use engine alloys. This will help guide future material specifications if one or more of these metals becomes in short supply. Conservation through process technology will be achieved by advancements in those net-shape and tailored-structure processes that minimize strategic material input requirements. This will lower total usage. And in the longer term, development of alternate materials that replace most strategic metals with those highly available in the U.S. could lead to a substantial reduction in the U.S. dependence on foreign sources. Both of the later two technology areas will help conserve the four strategic metals Co, Cb, Ta, and Cr.

EARLY COSAM ACTIVITIES

COSAM efforts began in FY'80. Efforts on planning and organizing are still underway. In addition to the planning activities, several small research activities have been initiated. These research activities focus on two of the three major thrusts of COSAM - strategic element substitution and development of alternate materials. Special emphasis of these initial efforts is on developing a fundamental understanding of the role of strategic elements in current aircraft engine alloys so that effective alloying element substitution can be conducted. Similarly, in the development of alternate materials, a basic understanding of materials properties and alloying concepts is being emphasized. Consequently, university grants play a major part in COSAM. In addition, cooperative programs with industry augmented by in-house research at the NASA Lewis Research Center comprise the approach used in these initial projects. This cooperative approach will continue to be followed in COSAM and industry, universities, and government in-house research will each play a key role. The subsequent paragraphs will describe in some detail early COSAM research efforts.

Strategic Element Substitution

Four metals were mentioned previously as being classified as high priority strategic metals. Cobalt was selected from these four metals for the early COSAM strategic element substitution research. The basis for selecting cobalt was twofold. First, the largest single use of cobalt in the U.S. is in superalloys for jet engine applications as was shown in figure 9 (Ref. 3). Many of the other applications indicated in figure 9 are also important to the nation's economy and security as well. Secondly, the specific roles that cobalt plays in nickel-base superalloy fabrication and performance has not been clearly established. Most superalloys currently in use were developed at a time when cobalt was plentiful and inexpensive. Literature results (Ref. 4) are conflicting as to the role that cobalt plays in nickel-base superalloys in important areas such as phase stability, γ' partitioning, strength, fabricability, and oxidation and hot corrosion resistance. Because of these uncertainties, there exists a strong possibility that the strategic element cobalt can be substantially reduced or possibly eliminated from several superalloys without sacrifice of the key properties for which these alloys were selected for engine service.

Four nickel-base and one cobalt-base superalloys were selected for this investigation. The five alloys are listed in figure 12 along with their typical applications in the aircraft engine industry, the forms in which the alloys are used, and remarks as to why they were selected for this activity. Applications include turbine disks, turbine blades, and combustors. A variety of product forms are represented by the applications of the five alloys as noted in figure 12. The selection of the five alloys was based primarily upon the considerations given in this figure. Waspaloy* was selected because it represents the highest tonnage of cobalt now in commercial aircraft engines. Selection of Udimet-700* was based on the fact that this alloy is used in the as-cast, as-wrought ingot, as-wrought powder, and as-HIP powder metallurgy fabricated conditions. The potential for determining the impact of cobalt on both conventionally-cast as well as on single crystal turbine blades was the reason for selecting Mar-M247*. Rene' 150* was chosen because it is one of the most advanced directionally solidified alloys. The wrought, sheet alloy HA-188* was selected because it represents one of the largest uses of a cobalt-base alloy in aircraft engines.

The primary purpose of the cobalt strategic element substitution research is to determine the fundamental role of cobalt in a wide variety of nickel-base superalloys and in a high-use cobalt base superalloy. A secondary purpose is to develop the methodology to explore the roles of other strategic elements in similarly chosen alloys so as to have maximum impact on a wide range of users.

Figure 13 shows the participants in this COSAM effort on cobalt strategic element substitution. These initial research efforts are planned for a three-year period and consist of cooperative programs involving universities, industry, and NASA Lewis Research Center. Nominal compositions of the five alloys given in figure 13 indicate that cobalt content ranges from 10 percent in Mar-M247 to 39 percent in HA-188. In addition, the γ' phase ranges from 20 percent in Waspaloy to 65 percent in Rene' 150. The first phase in each research effort will involve substituting the less strategic element, nickel, for cobalt in incremental steps to a zero cobalt content. The effect of this substitution on properties and phases present, such as γ' , will make up the major portion of the research effort in the first year of each program element. Efforts in subsequent years will be directed at identifying and optimizing alloying elements as substitutes for cobalt in the five alloys so as to maintain the key properties of these alloys.

The cooperative nature of the research being conducted on Waspaloy and Udimet-700 is illustrated in figure 14. The role of industry as represented by Special Metals Corporation is outlined. Their primary role is to characterize and optimize fabrication and heat treating procedures for the reduced

*Trademarks

Waspaloy	United Technologies Corporation
Udimet	Special Metals Corporation
Mar-M	Martin Marietta Corporation
Rene'	General Electric Corporation
HA	Cabot Corporation

cobalt Waspaloy and Udimet-700 alloys. The university role in this effort is also shown in figure 14. Columbia University will be involved with mechanical property characterization, structural stability, microstructural features, and theoretical formulations to identify future alloy modifications if required for the second phase of the project. Purdue University will be primarily responsible for microstructural and microchemistry characterization of the reduced cobalt content alloys. To round out the program, NASA Lewis Research Center will be involved in further mechanical and physical metallurgy characterization of the alloys as shown in figure 14. The output of this cooperative effort is expected to be a clearer understanding of the role of cobalt in nickel-base superalloys.

Some preliminary results on the effects of reducing cobalt in Waspaloy, a 13 percent cobalt alloy, are shown in figure 15 (Ref. 5). Tensile strength appears to be insensitive to the amounts of cobalt in the alloy. However, rupture life decreased with decreasing amount of cobalt in Waspaloy. Further testing will be required to better characterize this apparent effect.

Similar effects of cobalt on the rupture life of Mar-M247 have been determined as shown in figure 16 (Ref. 6). A possible contributing cause to this reduction in rupture life is the decrease in amount of γ' in this alloy with decreasing cobalt content as shown in figure 17. Also shown in figure 17 is the change in γ' composition. As cobalt is removed from the alloy, the largest change in the composition of γ' is the increase in tungsten content. Further studies are underway to clarify the role of cobalt in this alloy.

The research efforts on Udimet-700 and Rene' 150 parallel the previously described efforts on Waspaloy and Mar-M247. It is anticipated that these studies will lead to an understanding of the fundamental role of cobalt in a variety of conventional and directional nickel-base superalloys. These results should provide an improved technical base to develop modified superalloys in later stages of COSAM, as illustrated in figure 18.

Alternate Materials

Research in this area must be considered to be high risk and long range, but it has the potential of a high payoff in terms of significantly reducing the nation's dependence on strategic materials. As an example of alternate materials, intermetallic compounds are currently being investigated for possible structural applications. Initial efforts are centered on nickel and iron aluminides. Successful development of this type of alternate material offers the possibility of partially or totally replacing all the strategic materials in components where intermetallic compounds can be utilized.

Intermetallic compounds are of interest because of their potential high temperature strength as shown in figure 19 (Ref. 7). It can be seen in this figure that nickel aluminides have the strength capability of competing with current nickel-base alloys. However, a possible disadvantage of this type of material is that simple binary aluminide compounds have shown a lack of room temperature ductility (Fig. 20). The factors which influence the high ductile-

to-brittle transition temperature of nickel aluminide ($\sim 600 + ^\circ\text{C}$) are currently being investigated. A NASA grant with Dartmouth University is aimed at understanding the fundamental deformation mechanisms in nickel aluminide. From these investigations, methods of improving the low temperature ductility of nickel aluminide may be suggested. An accompanying in-house research project at NASA Lewis Research Center is focusing on the high temperature mechanical properties of aluminides. These studies can provide a fundamental basis for more extensive research to develop these nonstrategic, alternate materials as shown in Figure 21.

COSAM PLANS

Future COSAM efforts can build on the fundamental understanding from the early research for cobalt substitution, as was shown in figure 18. Major efforts will be devoted to developing, and if warranted, to scaling-up low or no-cobalt nickel base superalloys for fabrication into various components. Demonstration of continued promise could also lead to verification in engine tests by major engine producers. Similar efforts will also be conducted for other strategic metals such as columbium and tantalum.

In the area of alternate materials, much more work will be required to develop materials such as intermetallic compounds. As was shown in figure 21, initial efforts will focus on fundamental studies aimed at improving low temperature ductility and high temperature strength of FeAl and NiAl intermetallics. Complete property characterization will follow on more promising compositions. Reiterations of these basic steps will be required to further optimize the alternate materials and make them viable candidates as structural materials for aircraft engines. Scale-up and rig testing of promising compositions for blades and vanes will follow. The development of alternate materials will help conserve the strategic metals Co, Cb, Ta, and Cr.

A third area of the COSAM consideration involves conservation through improved materials processing technology. Although none of these activities have been initiated, plans have been made for investigating processing technology in such areas as advanced melting techniques, tailored fabrication, advanced coatings, joining techniques, and fabrication efficient processes. A reduction in strategic material usage should result from these processing technologies. For example, early efforts on near-net-shape fabrication of a turbine disk (Ref. 8) have been shown to be able to reduce input material weight compared to conventional casting/forging practice and further gains appear possible. Improved processing technology will also help conserve the strategic metals Co, Cb, Ta, and Cr.

CONCLUDING REMARKS

This paper has presented NASA's COSAM efforts and planning. The primary points are summarized below:

1. Advancements in materials technologies are needed to provide the aerospace industry with alternative materials options in the event of future strategic metal shortages or excessive price increases.
2. The primary role of NASA's COSAM efforts will be to address strategic material problems within the aerospace industry. COSAM should make contributions to a national data base that will benefit many other domestic industries as well.
3. COSAM was designed to involve cooperative research efforts with industry (alloy producers, component fabricators, and engine manufacturers), with universities, and with government research facilities (primarily the Lewis Research Center).

REFERENCES

1. Mineral Commodity Summaries 1979. Bureau of Mines, U.S. Department of the Interior, 1979.
2. "Aerospace Review and Forecast 1979/80", Aerospace, Vol. 18, No. 1, Winter, 1980, p. 4.
3. Mineral Industry Surveys, Bureau of Mines, U.S. Department of the Interior, December 1979.
4. Tien, J. K.; Howson, T. E.; Chen, G. L.; and Xie, X. S.: "Cobalt Availability and Superalloys", Journal of Metals, October 1980, pp. 12-20.
5. Maurer, G. E.; Jackman, L. A.; and Domingue, J. A.: "Role of Cobalt in Waspaloy", Superalloys 1980, J. K. Tien, ed., ASM, Metals Park, OH, 1980, pp. 43-52.
6. Nathal, M.: "The Role of Cobalt in a Nickel Base Superalloy". Presented at the AIME Annual Meeting, February 22, 1981, Chicago, IL.
7. Schulson, E. M.: "The Ductility of Polycrystalline NiAl", Presented at NASA Lewis Research Center, September 1979.
8. Dreshfield, R. L.; and Miner, R. V., Jr.: "Applications of Superalloy Powder Metallurgy for Aircraft Engines", 1980 International Powder Metallurgy Conference, Washington, DC, June 22-27, 1980.

FIGURE 1

COSAM BACKGROUND

STRATEGIC MATERIALS

● DEFINITION: THOSE PREDOMINANTLY OR WHOLLY IMPORTED ELEMENTS CONTAINED IN THE METALLIC ALLOYS USED IN AEROSPACE COMPONENTS WHICH ARE ESSENTIAL TO THE STRATEGIC ECONOMIC HEALTH OF THE U. S. AEROSPACE INDUSTRY

● SURVEY RESULTS

A. S. M. E. GAS TURBINE PANEL SURVEY

STRATEGIC ELEMENTS IDENTIFIED

Cb, Co, Cr, Ta, AND W

NASA AEROSPACE COMPANY SURVEY

(ADDITIONAL ELEMENTS)

Mn, Pd, Pt, Sn

CS-81-1712

FIGURE 2

STRATEGIC ELEMENT FOCUS

HIGH PRIORITY

- Co SUPERALLOYS LARGEST SINGLE USER (30% OF TOTAL)
- Cb SUPERALLOYS LARGEST SINGLE USER (28% OF TOTAL)
- Cr CRITICAL TO ENVIRONMENTAL RESISTANCE OF ENGINE COMPONENTS
- Ta CRITICAL TO ADVANCED ENGINE ALLOYS

LOWER PRIORITY

- W NEW U. S. MINES ON STREAM, PROJECTED SELF-SUFFICIENCY BY 1985
- Mn WIDELY USED IN STEEL INDUSTRY, HOWEVER POTENTIAL LOW COST ALTERNATIVE TO Ni
- Pd, Pt USED FOR ELECTRICAL/ELECTRONIC APPLICATIONS
- Sn USED FOR AI AIRFRAME ALLOYS AND IN SOME Ti ENGINE ALLOYS

CS-81-1711

FIGURE 3

STRATEGIC METALS ARE CRITICAL TO TURBINE ENGINES

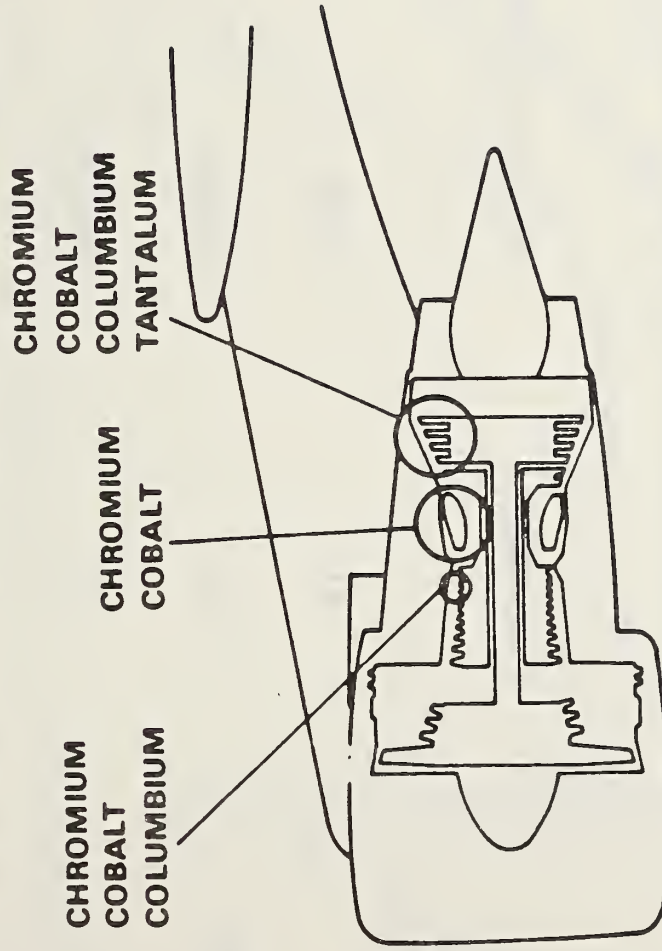

NEEDED FOR PERFORMANCE AND LONG LIFE

- COBALT – HIGH TEMPERATURE STRENGTHENER
- COLUMBIUM – INTERMEDIATE TEMPERATURE STRENGTHENER
- TANTALUM – OXIDATION RESISTANCE
- CHROMIUM – CORROSION RESISTANCE

CS-81-1713

FIGURE 4

U. S. AEROSPACE IS VULNERABLE TO SUPPLY INSTABILITIES

METAL	% IMPORTED	MAJOR FOREIGN SOURCE
COBALT	97	ZAIRE
COLUMBIUM	100	BRAZIL
TANTALUM	97	THAILAND
CHROMIUM	91	SOUTH AFRICA, ZIMBABWE

CS-87-4354

FIGURE 5

U.S. AEROSPACE IS VULNERABLE TO COST FLUCTUATIONS

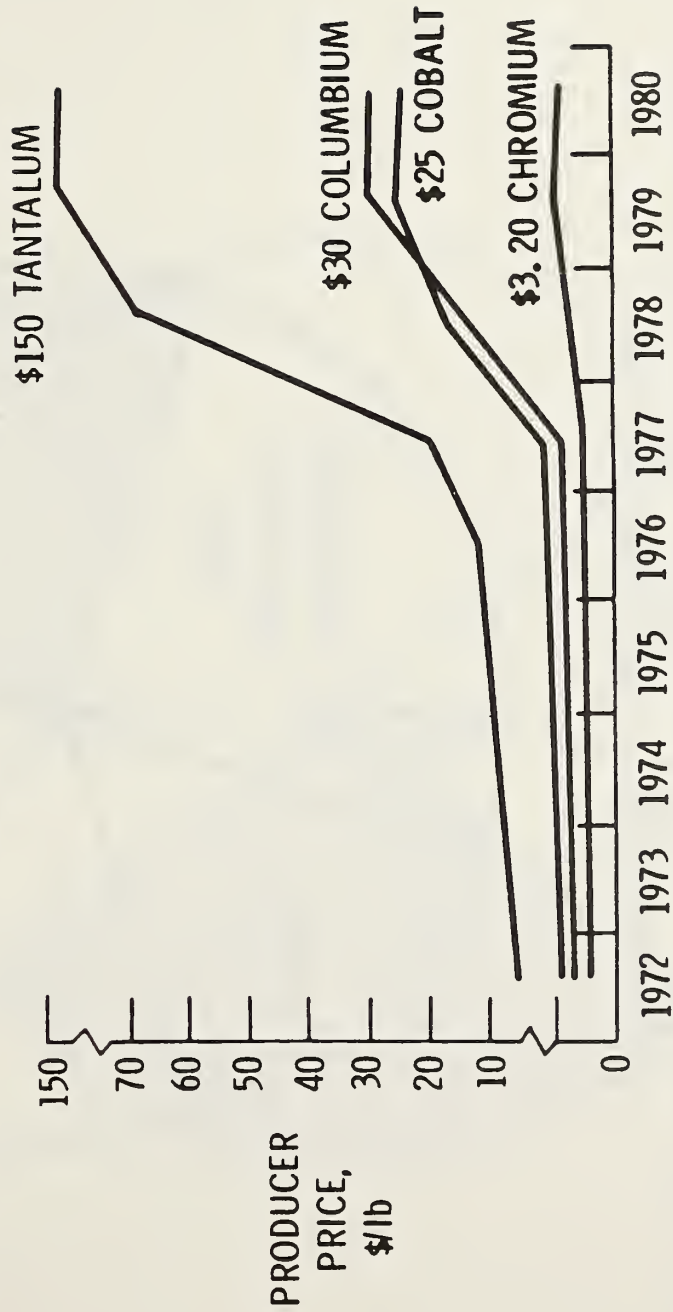

CS-80-4360

FIGURE 6

UNITED STATES 1979 CONSUMPTION OF COBALT
20.3 MILLION lb TOTAL CONSUMPTION

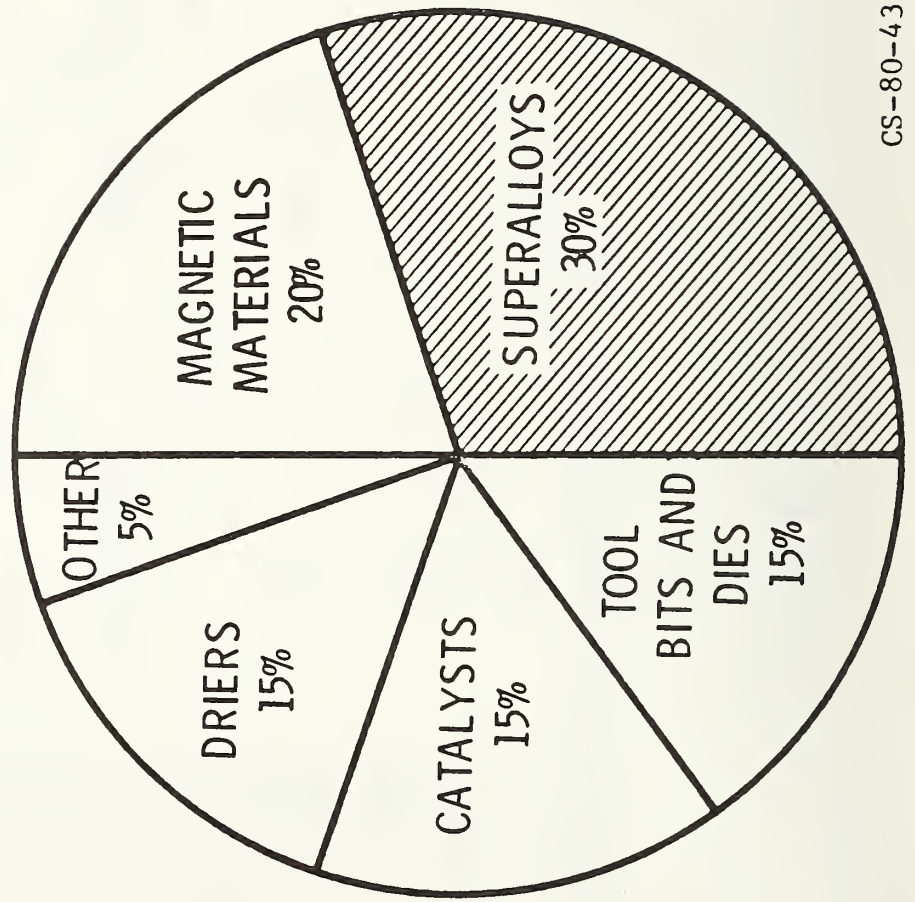

CS-80-4355

FIGURE 7

U.S. CONSUMPTION OF COLUMBIUM, 1979

(TOTAL POUNDS - 6.3 MILLION)

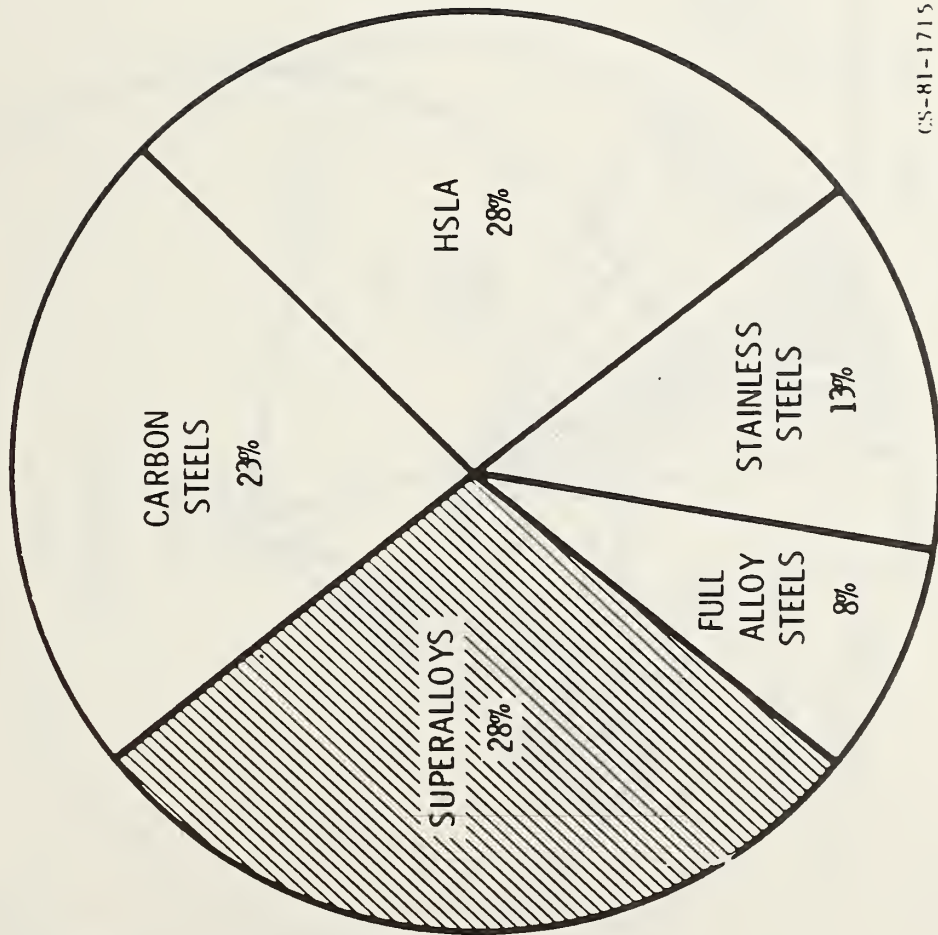

CS-81-1715

FIGURE 8

U.S. CONSUMPTION OF TANTALUM, 1979
(TOTAL POUNDS - 1.7 MILLION)

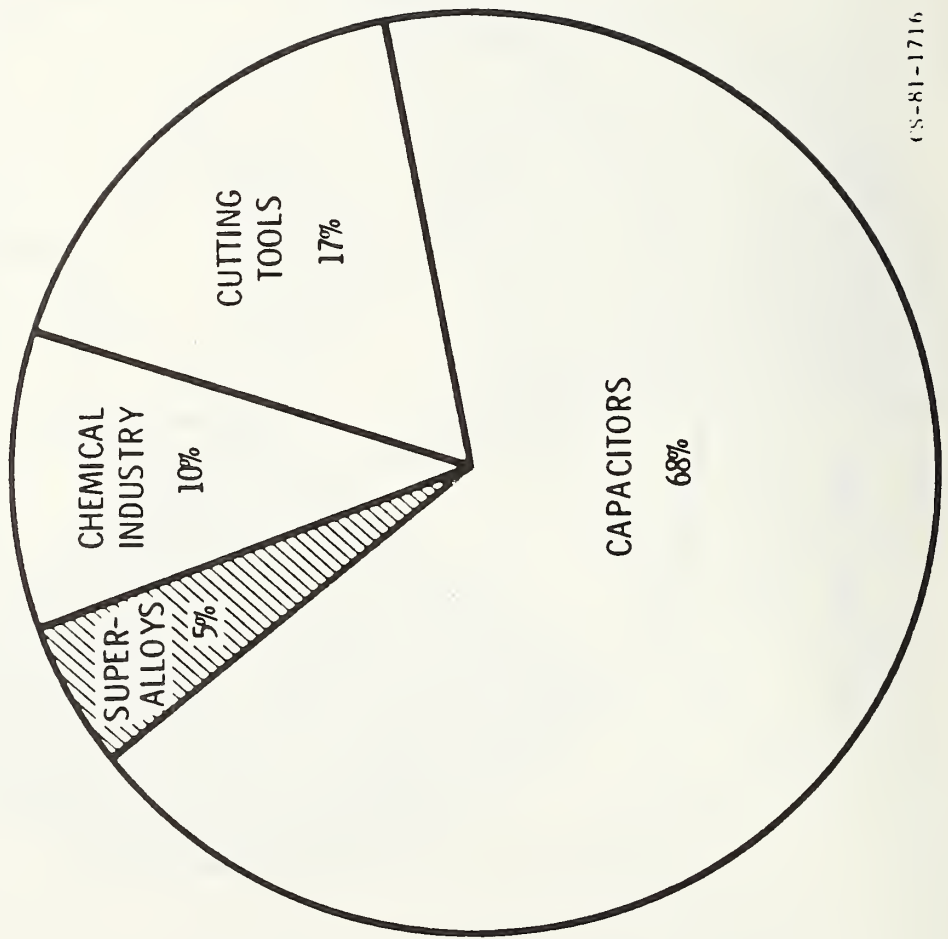

CS-81-1716

FIGURE 9

U.S. CONSUMPTION OF CHROMIUM, 1979
(TOTAL POUNDS CHROMIUM FERROALLOYS 1.0×10^9)

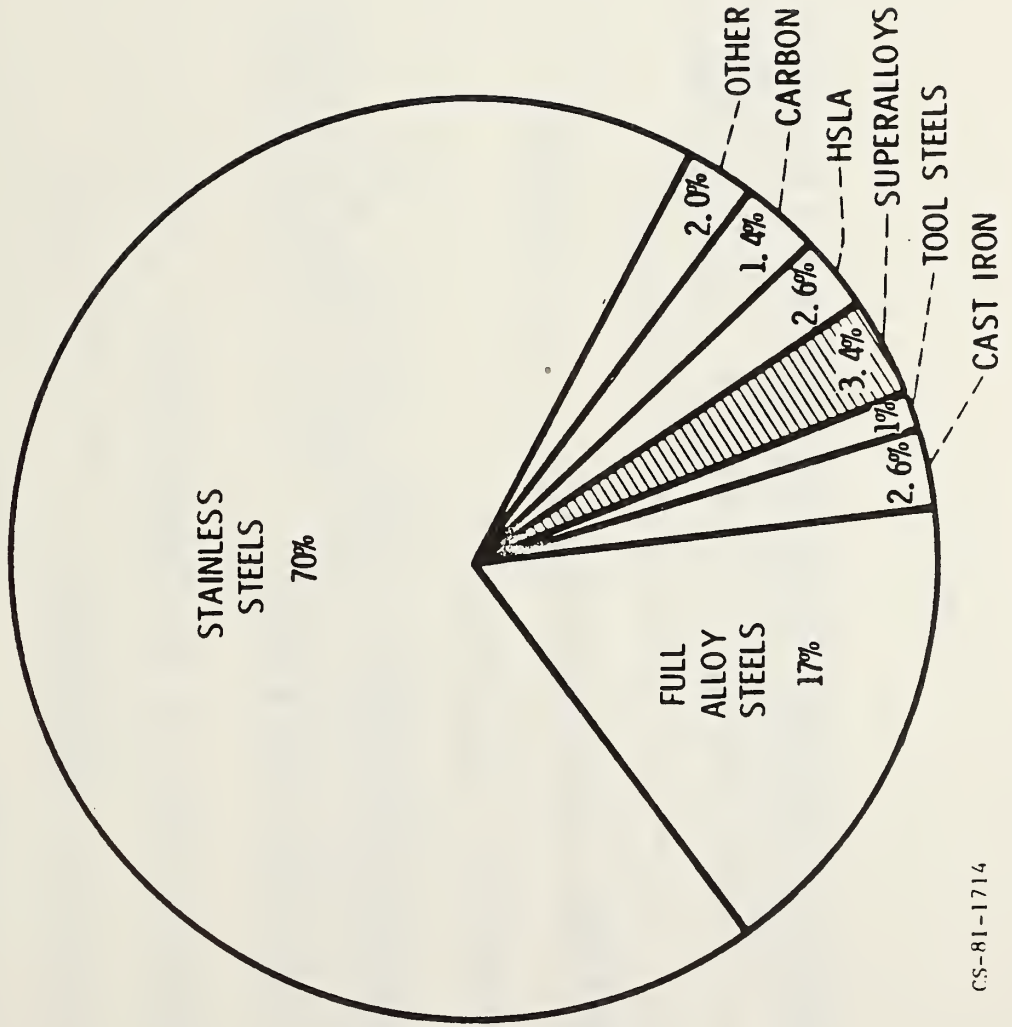

CS-81-1714

FIGURE 10

OPTIONS CONSIDERED IN PREPARATION FOR
STRATEGIC MATERIALS SHORTAGE

- EXPAND EXPLORATION
- IMPROVED RECOVERY
- STRATEGIC MATERIAL SUBSTITUTION ✓
- SCRAP RECLAMATION
- REDUCED WASTE IN PROCESSING ✓
- ALTERNATE MATERIALS ✓
- STOCKPILING
- CRITICAL MATERIAL INDEX

FIGURE 11

COSAM

PROGRAM OBJECTIVE AND APPROACH

OBJECTIVE:

- PROVIDE TECHNOLOGY OPTIONS WHICH WILL SUPPORT THE AEROSPACE INDUSTRY IN MAKING STRATEGIC ECONOMIC DECISIONS AIMED AT SIGNIFICANTLY REDUCING STRATEGIC METAL CONSUMPTION
 - Co, Cb, Ta, Cr, AND OTHERS AS IDENTIFIED

APPROACH:

- DEVELOP UNDERSTANDING OF ROLES OF Co, Cb, Ta, AND Cr IN CURRENT SUPERALLOYS
- IDENTIFY SUBSTITUTES AND LOW STRATEGIC METAL CONTENT ALLOYS
- DEVELOP PROCESS TECHNOLOGY THAT WILL MINIMIZE STRATEGIC METAL INPUT AND WASTE
- IDENTIFY ALTERNATE MATERIALS AND PROCESSES THAT HAVE HIGH LONG TERM POTENTIAL IN REDUCING STRATEGIC METAL USAGE (HIGHER RISK APPROACH)

CS-81-1710

FIGURE 12

SUPERALLOYS SELECTED FOR INITIAL COSAM ACTIVITIES

ALLOY	TYPICAL ENGINE APPLICATION	FORM	REMARKS	
WASPALOY	TURBINE DISK	FORGED	HIGHEST USE WROUGHT ALLOY IN CURRENT ENGINES	
UDIMET-700 (LC) ASTROLOY (RENÉ 77)	TURBINE DISK TURBINE DISK LP BLADES	FORGED AS-HIP- POWDER CAST	SIMILAR ALLOYS USED IN VARIOUS FORMS AND APPLICATIONS	
MAR-M247	TURBINE BLADES	CAST		CONVENTIONALLY-CAST, D.S. AND SINGLE CRYSTAL
RENÉ 150	TURBINE BLADES	DS-CAST		HIGHLY COMPLEX DIRECTIONALLY-CAST ALLOY
HA-188	COMBUSTORS	WROUGHT	HIGH USE COBALT-BASE SHEET ALLOY	

FIGURE 13

ELEMENTS OF INITIAL COSAM ACTIVITIES

PARTICIPANTS	ALLOY	NOMINAL COMPOSITION											γ'
		Ni	Cr	Cc	Mo	W	Ta	Re	Al	Ti	Hf		
COLUMBIA UNIV PURDUE UNIV SPECIAL METALS NASA-LEWIS	WASPALLOY	58	20	13	4	--	--	--	1.3	3	--	--	20%
COLUMBIA UNIV PURDUE UNIV SPECIAL METALS NASA-LEWIS	UDIMET-700	53	15	19	5	--	--	--	4.3	3.5	--	--	40%
CASE-WESTERN RESERVE UNIV TELEDYNE NASA-LEWIS	MAR-M247	60	8	10	.6	10	3	--	5.5	1	1.4	55%	
NASA-LEWIS	RENÉ 150	59	5	12	1	5	6	3	5.5	--	1.5	65%	
(TBD)	HA-188	22	22	39	--	14	--	--	--	--	--	--	

CS-80-4369

FIGURE 14

COOPERATIVE PROGRAM TO DETERMINE FUNDAMENTAL ROLE OF COBALT IN WASPALLOY AND U-700

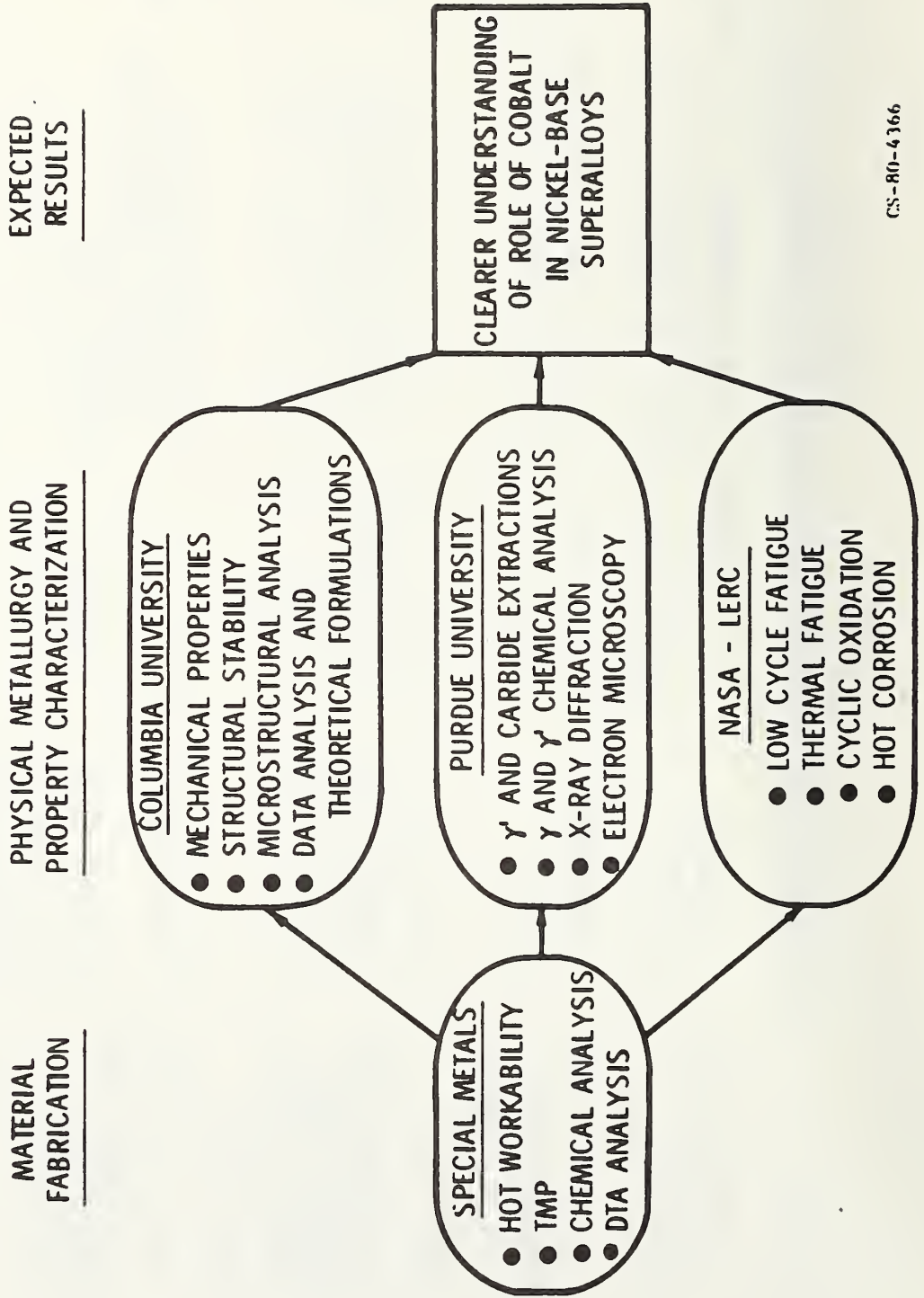
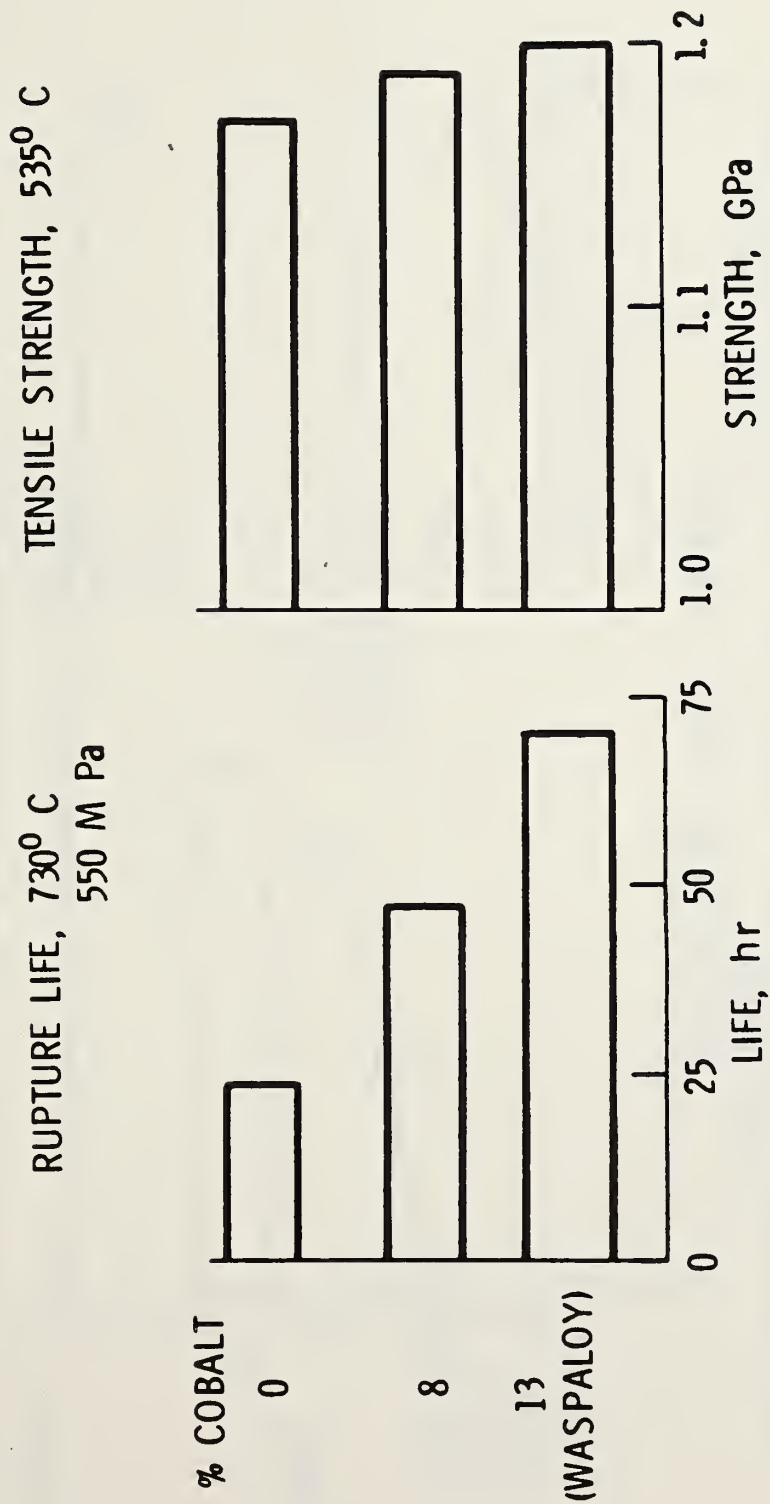

FIGURE 15

PRELIMINARY RESULTS OF REDUCING COBALT IN WASPALOY



CS-80-4357

FIGURE 16

PRELIMINARY RESULTS OF REDUCING COBALT IN MAR-M247
RUPTURE LIFE, 870°C; 360 MPa

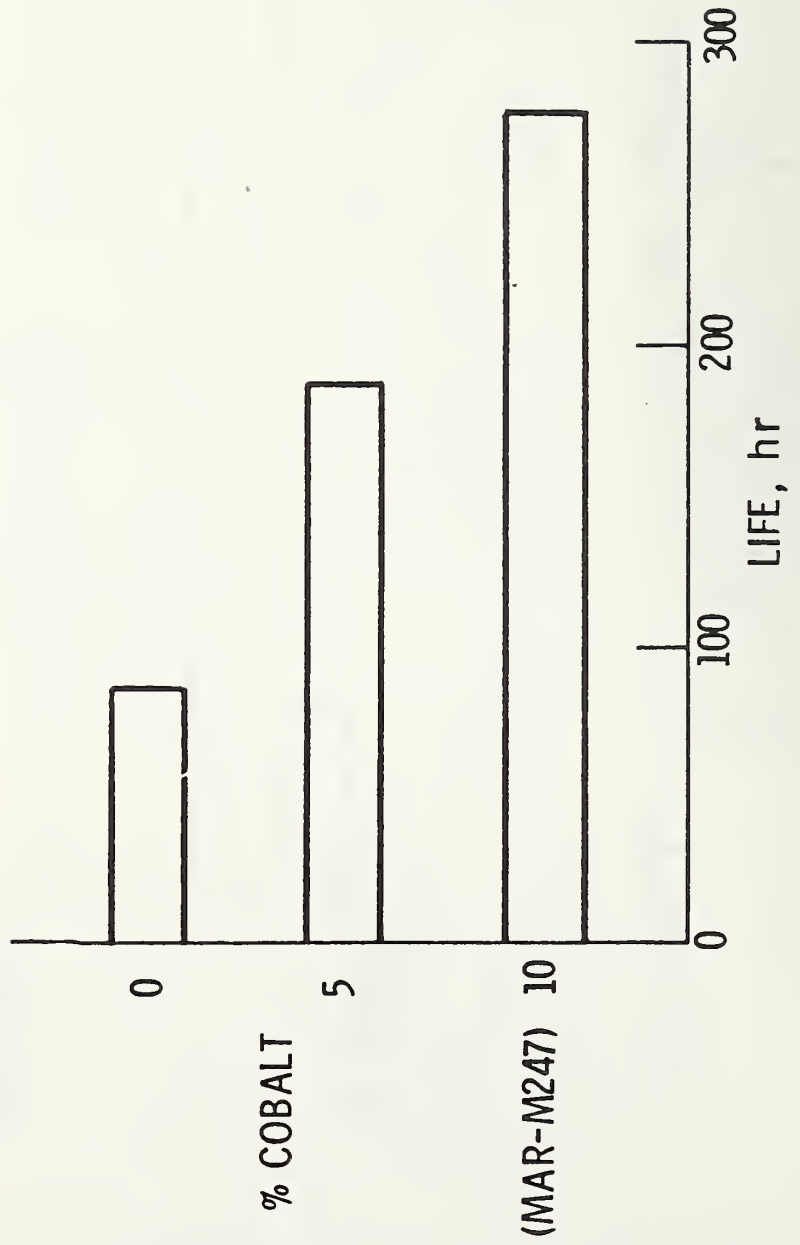
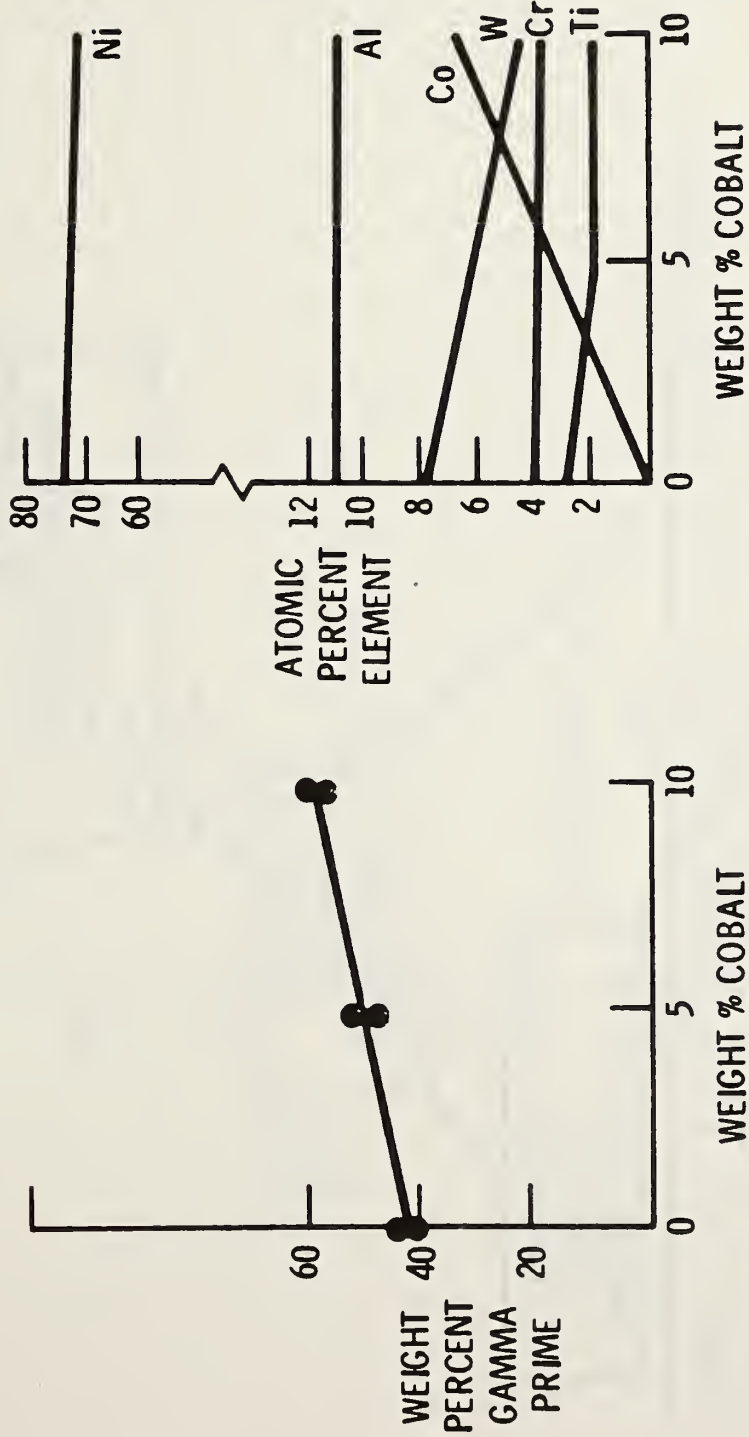

FIGURE 17

AMOUNT AND COMPOSITION OF GAMMA PRIME AS A FUNCTION OF COBALT CONTENT IN MAR-M247



CS-31-1709

FIGURE 18

PLANNED FLOW OF COSAM STRATEGIC ELEMENT SUBSTITUTION RESEARCH

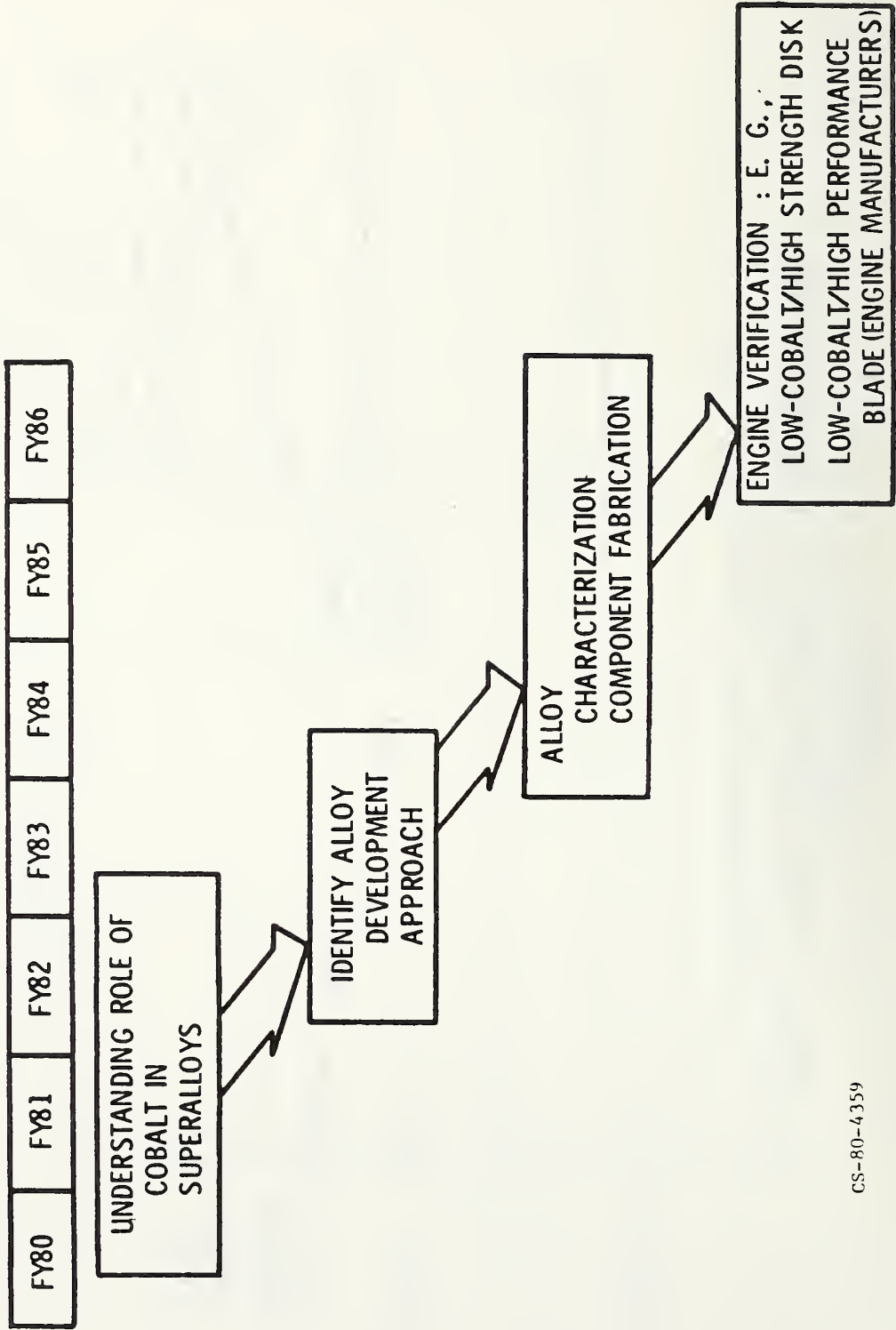

CS-80-4359

FIGURE 19
 TYPICAL STRENGTHS OF ALUMINIDES AND SUPERALLOYS

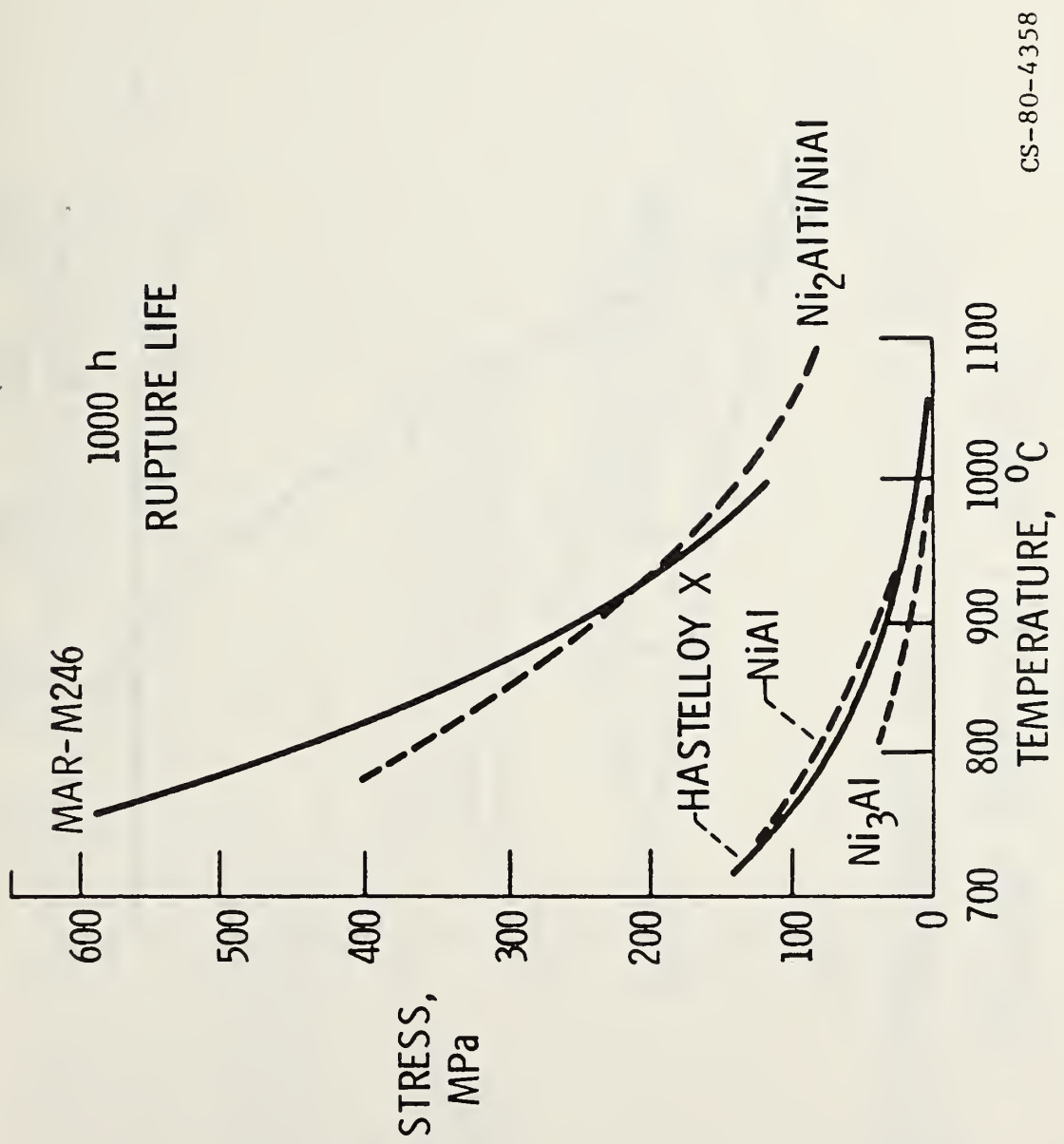

CS-80-4358

FIGURE 20

TYPICAL DUCTILITY VALUES FOR ALUMINIDES AND SUPERALLOYS

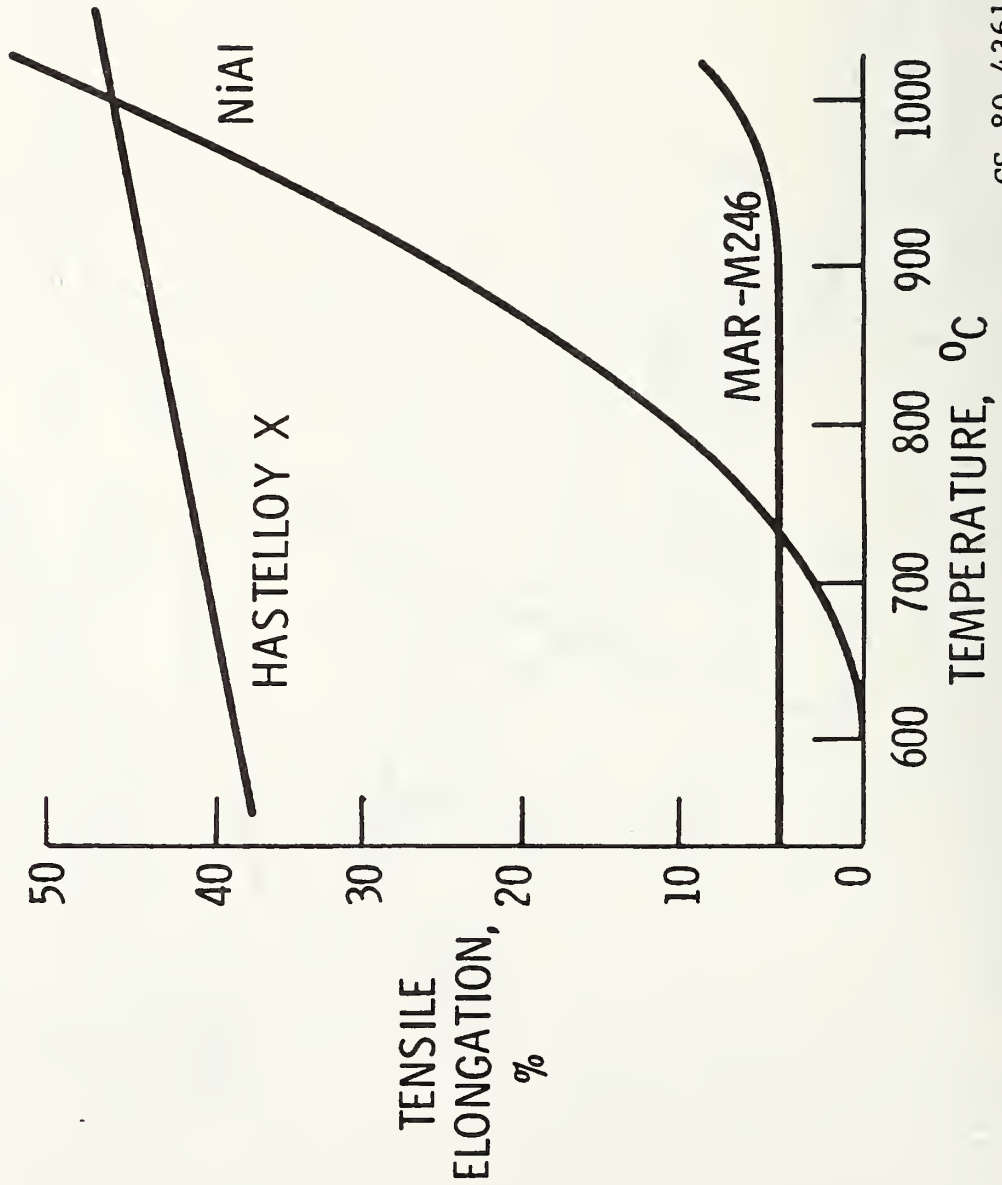

CS-80-4361

FIGURE 21

PLANNED FLOW OF COSAM ALTERNATE MATERIALS RESEARCH

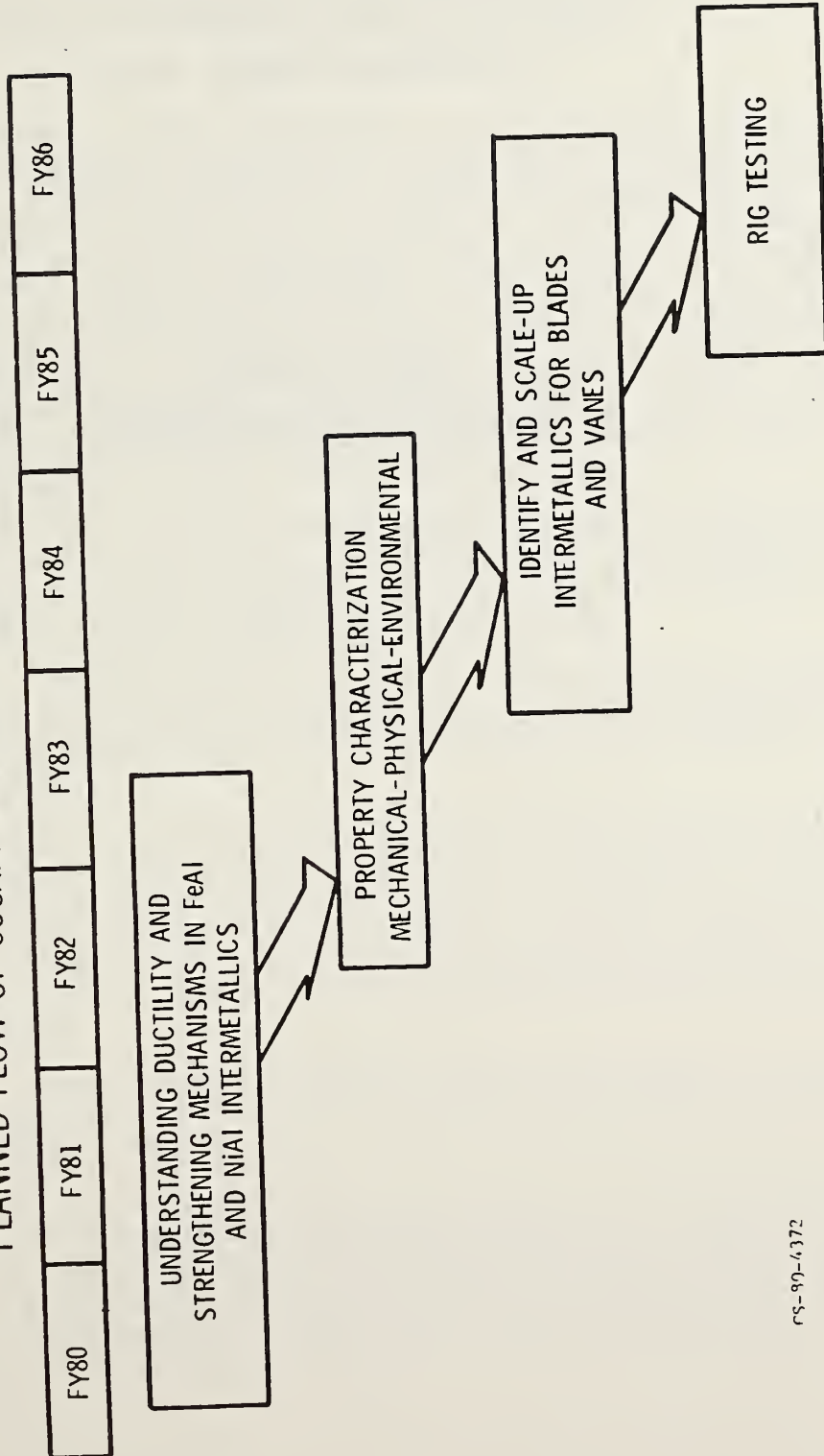

CS-90-6372

CHARGE TO WORKSHOP IN RELATION MATERIALS
POLICY LEGISLATION (PL 96-479)

John B. Wachtman
National Bureau of Standards

Workshop on Conservation and Substitution Technology
for Critical Materials

Vanderbilt University
June 17, 1981

John B. Wachtman, Jr.
Director, Center for Materials Science
National Bureau of Standards

Charge to Workshop

This workshop is being held primarily to assist in the preparation of a report to Congress required by a new law passed last October, the National Materials and Minerals Policy, Research and Development Act of 1980. This Act gives assignments for separate reports to the Departments of Commerce (DOC) and Defense (DOD) both due for delivery to Congress on October 1, 1981. It also assigns other responsibilities to the Department of Interior and to the President's Office of Science and Technology. Some ten agencies are assisting us with this DOC report, indeed the Department of Interior is a cosponsor of the present workshop. The present workshop is being held especially to develop information for the report required by the Department of Commerce, but should be very useful to the other agencies in their responsibilities also.

Slide 1 (P5-4). To give a broad perspective on the present workshop, let's take an overall look at the two reports which the Act requires. The DOD report is supposed to address critical material needs relative to defense and to identify items to meet their needs.

The DOC report is supposed to identify a specific materials needs case related to national security, economic well-being, and industrial productivity, to assess critical materials needs and to recommend programs to meet these needs.

Slide 2 (P5-5). The DOC report is narrower than the DOD report in one area and broader in another. It is narrower in the sense of being a case study. We selected the aerospace industry for the case study. With the aid of industry representatives and other experts, we held a workshop in Gaithersburg, Maryland on February 9-10, and selected six specific materials to typify the range of problem and opportunities associated with the critical materials problem.

The DOC report is broader than the DOD report in being explicitly concerned with industrial productivity and economic well-being as well as national security.

Slide 3 (P5-6). The DOC report will analyze the issues associated with supplies of all these materials including supply in all forms and stages of use; i.e., including parts and assemblies, not just raw materials. We want to know what policy options are available to the Government and which ones it should pursue. That is, what should the Government do or stop doing or what combination of these.

Slide 4 (P5-7). We clearly recognize that there are a whole spectrum of ways to respond to a supply problem, depending on the nature and severity of the problem. One set of supply oriented options would include increased domestic mining, increased stockpiling of materials, and a foreign policy directed more strongly toward security of supplies. These options are under study by the Department of Commerce team but are not the focus of the present workshop. We are concerned here with the second class of options; the technical options. These include substitution which we consider in two categories. First, substitution which taken place naturally as technology advances and the economics of new materials and processes leads to their use. We are calling this economically favorable displacement or just displacement. The second kind of substitution takes place in an emergency and may cause higher cost or lowered but adequate performance. We are calling this emergency substitution or sometimes just substitution for short.

Our present workshop is designed to get at opportunities and recommendations in this area of displacement, substitution, and conversion. We do not want to spend any time at this meeting on discussion of mining, stockpiling of materials, and the like because they are being treated by other parts of the Commerce team. We do want to get your ideas on where the most promising technical opportunities are for reducing our vulnerability to problem associated with critical imported materials, especially through the development of advanced materials. Bob Nash has prepared some questions which we hope you will help us with in the so-called "brain writing" sessions.

Slide 5 (P5-8). Many other agencies are assisting the Department of Commerce in preparing its report. We have asked two of these, the Department of Defense and the Department of Interior, which are named in the Materials Act of 1980 in connection with the Department of Commerce responsibility, to give brief summaries of their Research and Development program relating to critical materials. We have also asked for a presentation from the National Aeronautics and Space Administration because of its obvious importance to the Aerospace Industry. The other agencies listed on this slide have representatives here also in most cases. We appreciate their help and look forward to their active participation in the Workshop.

PL 96-479

DOD REPORT:

- 1) ASSESS CRITICAL MATERIALS NEEDS RELATED TO NATIONAL SECURITY.
- 2) IDENTIFY STEPS TO MEET NEEDS.

DOC REPORT:

- 1) IDENTIFY SPECIFIC MATERIALS NEEDS CASE RELATED TO NATIONAL SECURITY, ECONOMIC WELL-BEING, AND INDUSTRIAL PRODUCTION.
- 2) ASSESS CRITICAL MATERIALS NEEDS IN THAT CASE AND RECOMMEND PROGRAMS.
- 3) CONTINUE TO ASSESS ADDITIONAL CASES.

DOC REPORT

O **NARROWER IN FOCUS: A SPECIFIC CASE**

-- WE HAVE SELECTED THE AEROSPACE INDUSTRY

-- WITHIN AEROSPACE, AS EXAMPLES:

1) CHROMIUM

4) TANTALUM

2) COBALT

5) , RAPID SOLIDIFICATION TECHNOLOGY

3) TITANIUM

6) COMPOSITES

O **BROADER IN ANOTHER SENSE**

-- ECONOMIC

-- INDUSTRIAL, AS WELL AS

-- SECURITY

DOC REPORT

- o ISSUES ASSOCIATED WITH SUPPLIES OF SIX MATERIALS
- o POLICY OPTIONS
- o PROGRAM RECOMMENDATIONS

CLOSE COORDINATION

- 1) FEDERAL EMERGENCY MANAGEMENT AGENCY
- 2) DEPARTMENT OF THE INTERIOR
- 3) DEPARTMENT OF DEFENSE
- 4) CENTRAL INTELLIGENCE AGENCY
- 5) NATIONAL AERONAUTICS AND SPACE ADMINISTRATION
- 6) DEPARTMENT OF ENERGY
- 7) DEPARTMENT OF STATE
- 8) DEPARTMENT OF TRANSPORTATION
- 9) NATIONAL SCIENCE FOUNDATION

WORKSHOP GOALS

MAIN GOALS:

DEFINE TECHNICAL OPPORTUNITIES FOR

- DISPLACEMENT
- CONSERVATION
- SUBSTITUTION

OF IMPORTED MATERIALS

IDENTIFY TARGETS FOR "INFORMATION STOCKPILE"

SUBSIDIARY GOAL:

CONVEY VIEWS ON FEDERAL ACTION THAT WOULD BE DESIRABLE TO FACILITATE THE DEVELOPMENT OF ADVANCED MATERIALS.

CONSERVING CHROMIUM

David C. Goldberg
Westinghouse Electric Corporation

June 1981

CONSERVING CHROMIUM

D. C. Goldberg
Westinghouse Electric Corp.

In preparing this overview talk I have drawn heavily on the NMAB-NAS study "Contingency Plans for Chromium Utilization" issued in 1978 as the data base, the summary, and the recommendations contained in it are as valid today as it was at that time.

Another excellent resource was the book "World Mineral Trends and U.S. Supply Problems," Resources for the Future, R-20, December 1980. The authors of this book highlighted the mineral chromium as one having an undue vulnerability to supply disruptions and subsequent economic impact.

It is a well known fact that, with the exception of Russia, no developed country, which has a large market for materials dependent on chromium, has large deposits of chromite. These countries have had to import such large quantities of chromite that the supply-demand scenario can, at various times, reach "crisis" situations. Given the current trend of increasing U.S. dependency on the continuing availability of South African chrome ores, it is significant that the current administration is fostering an environment, both through its actions and deeds, that is considerably more favorable for developing a strategic minerals policy that will go beyond the long prevailing and inadequate "emergency" concept. We also see the United States Senate and House moving forward on implementing the provisions of National Materials and Minerals Policy,

Research and Development Act of 1981 (P.L. 96-479) signed by President Carter on October 21, 1980.

The long range commitment to a strategic minerals policy was emphasized when Secretary of Interior James Watt recently told the House Mines and Mining Subcommittee (March 26, 1981) that a strategic minerals policy is "not simply the establishment of emergency government action" but "policies that protect American jobs and investments, improve our balance of trade, revitalize the Nation's economy, and provide for the security of foreign mineral imports." He also told the Senate Energy and Minerals Subcommittee the following week that "it is imperative to take a national strategic view of the land use in the focus of mineral requirements 20 years or more down the road."

These statements plus administration actions* are aimed at ending South Africa's "polecat status" in the world if they cooperate in achieving an internationally-acceptable settlement for the independence of Southwest Africa. All of these moves provide a climate which could diminish the proportions of our current dependence on mineral supplies from hostile or politically sensitive areas.

It is fitting that Chromium is the first of the metals to be discussed in this three-day workshop as it is probably the one metallic element for which there is not an obvious substitute. The papers to follow, review recent actions in conservation and substitution.

*New York Times News Service - 5/30/81

Before we get into these specifics, I would like to present an overview of recent studies on this important element. Chromium is an element that imparts unique properties to the material(s) to which it is added, but it is not scarce and its price has been relatively low until recently. It plays a vital and almost irreplaceable role in widely disparate commodities, and chromium containing materials are used in a variety of essential military and industrial applications.

I thought it would be a good idea to begin the discussion on an historical note to remind us that the problem we are facing today is not all that new. Certainly, many of the rules of the game have changed. Energy costs and environmental factors have a lot to say about the materials we use today to manufacture goods.

But the basic solutions to the problem — identifying, substituting, recycling, stockpiling, exploring for alternate materials and developing new processes to refine and manufacture materials — have remained pretty much the same.

The United States faces only one type of "major mineral supply problem": an undue vulnerability, of some minerals due to contingencies that might either seriously disrupt supplies or cause a sharp upward movement of prices, with serious economic impacts. This is particularly true for chromium, in the form in which it is consumed by the steel industry (principally ferrochromium).

It is projected that United States consumption of chromite will decline, although at a lesser rate than in the recent past, while world consumption will increase by about 70 percent. United States ferrochromium consumption is expected to increase by approximately 60 percent, more than double in Japan, and quadruple in the Soviet Union. Accordingly, we will see some of the same economic and political measures used in a self-serving manner, to insure their uninterrupted ore supplies.

Chromium also presents no basic resource problem, and it appears as if the present tightness in mining capacity will diminish over the balance of the century. There may be some difficulty, however, in maintaining an adequate supply of refractory-type ore, owing to concentration in the Philippines. Ferrochromium is likely to become increasingly concentrated in southern Africa.

Chromium exemplifies the problem of long-term exposure to supply contingencies, which occurs when there is physical concentration of supply in areas (South Africa) that are unusually subject to politically motivated supply disruptions. Higher energy costs and environmental problems have driven United States ferrochromium processing to South Africa also, thus adding to our vulnerability to a supply interruption.

Chromium is also exposed to short term contingencies of embargoes and racial conflicts in the countries of chromium origin. The ample supply of chromite ore offsets the impact but is still a potential problem with respect to the ferrochromium. Given the global political situation,

the possibility of forming a chromium cartel that could produce severe economic penalties and industrial disruptions by interrupting United States chromium imports is of serious concern.

Although chromium is found in various minerals, the ore known as chromite is the sole commercial source. Historically, chromite has been classified into three general categories: metallurgical, chemical, and refractory. Technological advances permitted considerable interchangeability among the various grades, particularly in respect to the chemical grade, which can be used in all industries. The principal substitution has been to chemical for metallurgical. Refractory (high alumina) ore has tended to dominate its market.

Because of complacency, materials research has not received the proper level of attention and funding it deserves. Increased awareness of materials during periods of war resulted in increased funding of research. Out of this effort, of course, came synthetic rubber, new electrical insulating materials, a host of new alloys, polyester fibers, polyethelene, revolutionary molding compounds and other materials.

In many areas of materials research, we are going to have to run very fast just to stand still — just to hold on to the quality of life we enjoy today. This is particularly true in the metals area.

I think the future of materials research work will be devoted to the development and refinement of alternate materials, and to the exploration of ways in which we can make more effective use of the materials we do have.

Expenditures in materials research and development in this country peaked in the 1960's. While current dollar annual expenditures in the field are five times what they were in the 1950's when viewed from the perspective of inflation, investment in materials research has actually been on the decline for several years. As is the case with so many other areas of research, we have definitely seen a decline in innovative risk taking in the past 10 years. As a result, R&D in the field has been much more selective and cautious.

It is true that when we realize we have a severe shortage, R&D has been funded. Cobalt shortages, for example, have provided the economic incentives for industry to seek substitutions. The electrical industry uses cobalt to make magnets, but we are learning to make rather remarkable magnets without cobalt.

When R&D has not been funded, we are in trouble. Chromium is perhaps the classic example. We as a nation are behind the times in chromium substitution research. This is largely because of the research climate that exists today in this country — a climate that is burdensome to industry, and quite different from the cooperative climate that exists between industry and government in countries such as Japan and West Germany.

Government policy has been channeling resources into energy research, which is obviously vital to our well-being. But government, industry and the universities have all virtually ignored materials research.

It is clear that in order to ward off an impending materials crisis, we must make materials research a national priority. Materials research has been largely directed to knowing more about the materials we have. But little has been done to search for replacements and to explore totally innovative ideas.

Our government has been for years shooting itself in the foot insofar as the health of our domestic mineral industries is concerned. In order to stimulate the necessary domestic supply of critical materials, the government will have to get its act together in the form of a national materials policy.

For too long uncoordinated government policies on land use, environment, stockpiling, taxes, and depreciation allowances have been made without weighing their adverse effect on domestic mining and processing of critical materials. We now see ferro-alloy plants shutting down in the United States and opening in South Africa, and a copper refinery shut down here and the operation moved to Japan, making us more rather than less dependent on foreign sources. Even our foreign policy has at times jeopardized the flow of critical materials. All of these policies must be changed so that full recognition of critical materials concerns is given, hence the need for an overall national materials policy that becomes a factor in our foreign policy negotiations.

The same rationale, I believe, applies to materials. The only way to prevent the formation of an OMEC is to develop new materials, and new materials processes, that will decrease the bargaining power of the sub-Saharan nations.

Like the energy problem the materials problem ultimately boils down to a basic problem of supply and demand. It is fundamentally a problem of economics that is addressed in both short and long term planning of business and government working in partnership.

And since when it comes to materials, the United States is a have-not nation, ingenuity is the only card we have to play.

Our mineral resources, after all, are finite on our planet. Our challenge today is to get smarter about the minerals and materials we do have. We have to learn how to extract these minerals more efficiently from nature. We have to learn how to produce materials from these minerals using less energy. And we have to learn how to recover more of the materials we use in society.

These are all challenges for technology. Government policies can help. Certainly economic and energy factors will play key roles in our future material consumption habits.

But technology remains the driving force required to transform the finite resources of our planet into economic realities.

The efforts of technology, however, must be supported by prudent government planning and increased public awareness.

From the conclusions of the various authoritative studies made on chromium in recent years, it is clearly apparent that a supply disruption of several years would create serious — both short and long term — economic problems. When this is viewed in terms of where the world's chromite supply will be located in the next century, I feel it is necessary to initiate programs with respect to exploration, stockpiling, recycling, substitution, and alloy development at an accelerated rate.

WORLD CHROMIUM ORE RESOURCES

Country	Known Ore Reserves		Known Potential Ore	
	Million Short Tons Ore	% World	Million Short Tons Ore	% World
South Africa	1,194	62.4	2,333	76.5
Rhodesia	626	32.7	626	20.5
USSR	24	1.2	25	0.8
Philippines	5	0.3	< 1	< 0.05
Turkey	2	0.1	6	0.2
All other	<u>63</u>	<u>3.3</u>	<u>58</u>	<u>2.0</u>
Total	1,914	100.0	3,049	100.0

DEPLETION TIMES FOR KNOWN CHROMIUM ORE RESOURCES

Country	Known Chromium Ore Resources (million short tons)	1973 Chromium Ore Production (million short tons)	Depletion Time at 1973 Production (years)
South Africa	3,527	1.85	1,906
Rhodesia	1,252	0.61	2,052
USSR	49	2.13	23
Philippines	6	0.65	9
Turkey	8	0.63	13
All Other	<u>121</u>	<u>1.58</u>	77
Total	4,963	7.45	666

NOTE: Based on data from the Institute of Geological Sciences, 1975.

CHROMIUM

- IMPARTS UNIQUE PROPERTIES
- IRREPLACEABLE IN STAINLESS STEEL AND HRA
- NO CHROMIUM-FREE SUBSTITUTES FOR CRITICAL APPLICATIONS
- U.S. COMPLETELY DEPENDENT ON IMPORTS
- NO TECHNOLOGICAL ACTION IDENTIFIED TO U.S. VULNERABILITY OF LONG TERM EMBARGO

CHROMIUM CONSUMPTION IN THE UNITED STATES
 BY PHYSICAL FORM IN 1964 & 1976
 (1,000 SHORT TONS CONTAINED CHROMIUM)

	1964	1976
Metal Production		
High-carbon ferrochrome	83 (21%) ^a	159 (44%)
Low-carbon ferrochrome	104 (27%)	54 (15%)
Ferrochrome silicon	32 (8%)	26 (7%)
Other	<u>10</u> (3%)	<u>9</u> (3%)
Subtotal	229 (59%)	248 (69%)
Refractories	114 (29%)	46 (13%)
Chemicals	<u>45</u> (12%)	<u>64</u> (18%)
Total	388 (100%)	358 (100%)

NOTE: Data from U.S. Bureau of Mines 1964 and 1976.

^a The figure in parentheses indicated the percentage of total U.S. chromium consumption.

RELATIVE IMPORTANCE OF METALS UTILIZING CHROMIUM IN 1964 & 1976

1964 Metal	Percent ^a	1976 Metal	Percent ^a
Steel		Steel	
Stainless	70.9	Stainless	69.8
Other alloys	<u>24.2</u>	Tool	1.2
Subtotal	95.1	High-strength low- alloy and electric	3.7
		Other alloy	16.2
		Carbon	<u>1.4</u>
		Subtotal	92.3
Iron castings	1.7	Iron castings	2.6
High-temperature alloys	2.2	Superalloys	2.5
Nickel and other alloys	<u>1.0</u>	Other alloys	1.7
Total	100.0	Miscellaneous	<u>0.9</u>
		Total	100.0

NOTE: Data from U.S. Bureau of Mines, 1964 and 1976.

^a Contained chromium as a percentage of U.S. metallurgical consumption.

KEY USES OF CHROMIUM IN ALLOYS (1974)

Material Group	Average Chromium Content (%)	Use of Metallurgical Chromium (%)
Stainless steels ^a	16.4	72
Alloy steels	1	14
High-temperature special alloys and Ni-Co-base alloys	18	7
Tool steels	6	2
Alloy cast irons	< 1	2
Miscellaneous (wear resisting alloys, welding, hard facing alloy, others)	--	3

NOTE: Data from American Iron and Steel Institute 1975.

^a Austenitic stainless steels contain an average of 17.9 percent chromium; ferritic stainless steels, 15.2 percent; and martensitic stainless steels, 12 percent.

PROCESS RELATED

- PROCESS CHANGES OFFER SAVINGS - 100,000 TONS/YEAR
- DUPLEXING MINIMIZES SLAG LOSSES
- SURFACE COATING HAS PROMISE
- CONTINUOUS STRAND CASTING, HIP, NEAR-NET-SHAPE CAST PREFORMS OFFER SAVINGS
- ALLOY AND LOW-ALLOY STEEL INDICATE A PROMISING AREA FOR CHROMIUM RECYCLING
- ISOTHERMAL FORGING, CHIPLESS MACHINING, PM PREFORMS, SCRAP RECOVERY HAVE POTENTIAL
- JOINING VERSUS MECHANICAL FASTENING
- STOCKPILE PROBLEM
- RECYCLING

PROSPECTS FOR CHROMIUM SAVINGS BY PROCESSING IMPROVEMENTS

Processing Step	Potential Savings - Category 1 ^a		Potential Savings - Category 2 ^b	
	1,000 Short Tons Chromium Per Year	% of 1977 Metallurgical Consumption	1,000 Short Tons Chromium Per Year	% of 1977 Metallurgical Consumption
Melting and refining	19	5.9	0	0
Casting	3	0.9	6	1.9
Mill product fabrication and manufacturing processing	0	0	9	2.8
Joining	<u>0</u>	<u>0</u>	<u>1.4</u>	<u>0.4</u>
Total	22	6.8	16.4	5.1

^a Technically feasible now.

^b Potentially feasible after 10 years of research and development.

PROSPECTS FOR CHROMIUM SAVINGS BY RECYCLING OF INDUSTRIAL WASTES

Source of Waste	Potential Chromium Savings ^a	
	1,000 Short	Percent of 1977
	Tons per Year	Segment Consumption
<u>Metallurgical</u>		
Ferroalloy slags	1.0	0.3
Stainless steel furnace dusts	2.5	0.8
Stainless steel grinding swarfs	2.0	0.6
Stainless steel mill scale	3.6	1.1
Stainless pickle liquor	0.8	0.2
Ferroalloy flue dusts	3.5	1.1
ECM and EDM sludges	1.3	0.4
Subtotal	<u>14.7</u>	<u>4.5</u>
<u>Refractories</u>		
Foundry sand	21	34
Chrome-bearing refractories	<u>19</u>	<u>31</u>
Subtotal	40	65
<u>Chemicals</u>		
Etching wastes	1.0 ^b	1.5
Plating wastes	2.0 <u> </u>	2.9
Catalysts	0.7	1.0
Chromate and dichromate, leather tanning, paint pigments, and textiles	0.4	0.6
Subtotal	<u>4.1</u>	<u>6.0</u>
Total	58.8	13.0

SUBSTITUTION RELATED

- 370,000 TONS/YEAR IN CHROMIUM SAVINGS IDENTIFIED
- END USE STAINLESS STEEL REQUIREMENTS INDICATE:
 - 10% COULD BE REPLACED WITHOUT DEGRADATION (32M LBS)
 - 50% MIGHT BE REPLACED WITH HIGH PROBABILITY OF SUCCESS (160M LBS)
 - 40% CANNOT BE REPLACED WITHOUT MAJOR IMPROVEMENTS
- HARDENABILITY IN WROUGHT AND CAST STEELS
- TOOL STEELS IRREPLACEABLE
- NON-FERROUS NOT A PROBLEM EXCEPT IN HTA AND CRA
- CERAMIC INDUSTRY OFFERS POTENTIAL WITH MODEST EFFORT
- CHEMICAL INDUSTRY MIXED

DESIGN RELATED

- DESIGN TEAM - BEST TECHNICAL APPROACH
- KEY CRITERIA - RECYCLING, AESTHETICS RELIABILITY
AVAILABILITY, LIFE CYCLE, ETC.
- INNOVATION AND ATTITUDE CAN IMPACT CONSUMPTION
- DESIGN FACTORS - NDE, SPECIFICATIONS
- INSTITUTIONS HAVE A MAJOR ROLE

RECOMMENDED ACTIONS

COMMODITY STOCKPILING

R&D TO IMPROVE RECYCLING

GUIDELINES FOR ENERGY CONSUMPTION CUTBACKS

STOCKPILING RELIABLE INFORMATION ON MATERIALS SUBSTITUTION

EXPANSION OF POTENTIAL FOR SUBSTITUTION TECHNOLOGY

"BRAIN WRITING"

- WHAT — IN ADDITION TO STOCKPILING — CAN BE DONE TO MINIMIZE THE LACK OF SUCH CRITICAL MATERIALS AS CHROMIUM?
- WHAT ARE THE OBSTACLES IN EXISTING LAWS AND REGULATIONS THAT PREVENT OR IMPAIR THE NATION'S PREPARING FOR CURTAILMENT OF FOREIGN SUPPLIES OF CHROMIUM?

COMPUTER SYSTEMS FOR DEVELOPING CHROMIUM
FREE STEELS FOR HARDENABILITY

Dale H. Breen
International Harvester Co.

COMPUTER SYSTEMS FOR DEVELOPING CHROMIUM
FREE STEELS FOR HARDENABILITY

Dale H. Breen
International Harvester Co.

Good morning, Gentlemen:

It's a pleasure for me to be a participant in this work shop and conference concerning strategic alloys. The subject that I am going to discuss, substitution based on hardenability, is indeed an appropriate one to be in this conference although it addresses only a small segment of the problem. I will have a number of exhibits (attached) that I'm going to use to help me demonstrate to you a cost motivated technology that we have used at the International Harvester Company for some time. The technology has broader inferences than that, however, and that is the purpose of my being here, to explain how it is applicable to threatened shortages of strategical alloys.

Fig. 1 shows a condition that has already been well-defined in the literature so I'll not dwell in this area. It demonstrates the location of our chrome resources and shows, in this instance, that the Western Hemisphere doesn't have very much. As can be seen, the seven million one-hundred thirty thousand short tons represents only a very small fraction of the world total. Fig. 2 summarizes the condition of the Eastern Hemisphere and the countries that are in that portion of the world. As you can see, their hemispheric total reserve of a billion eight hundred and thirty-four million three hundred and eighty thousand tons is quite a high fraction of the world total. Also one can see that it is mainly concentrated in South Africa and Southern Rhodesia but Russia also has a significant amount. It is not my purpose here to get into the political aspects of this but the very least one can say is that there is potentially a problem in obtaining chromium.

Now to move into the area that I want to address, that is, in the application of chrome-bearing steels for ground vehicles. There are many, many tons of steels used in structural applications, such as gears and shafts. Referring to Fig. 3, they are designated as chrome, chrome vanadium, nickel-chrome, nickel-chrome-moly-vanadium, chrome-moly and so forth as shown. These carry SAE or AISI numbers, such as the straight chrome steels which are the 5100 series, the nickel-chrome-moly steels are 4000 and 8600 type steels and so forth. The object of Fig. 3, though, is to show how many tons of chromium are required to make these steels based on 1978 production. This tonnage represents somewhere in the order of 10 to 12% of the total chromium used domestically. None of these steels are heat resistant or stainless steels. These are steels primarily for use in structural applications such as gears and shafts (refer Fig. 4). The technology associated with the engineering of such components is quite developed and very sophisticated. Fatigue strength, wear resistance and dimensional control are very important. They are applied in ground vehicles of all sorts. Automobiles, of course, highway trucks, earth-moving equipment, locomotives, etc. all use these type of steels in relatively high tonnage.

Now, another important factor is that the single most important aspect in their applications is their hardenability characteristics. They are generally purchased to standard hardenability bands rather than chemistry. To explain further, the point I want to make now is that worldwide, steels are bought and sold to hardenability bands (refer Fig. 5) and that hardenability is one of the most significant criteria

related to their performance in applications. Hardenability is the ease with which they may be hardened. This will be defined more explicitly later but the point I want to make is that there are standards, and that the standards are defined in terms of hardenability. Now I'd like to dwell in the area of semantics a minute because I am going to go in two different directions. When I talk substitution technology, I talk about two different concepts; replacement steels and alternate steels (refer Fig. 6). A replacement steel is a steel, by my definition, that has all of the essential hardenability characteristics of the steel it is going to replace. In other words, the hardenability bands are identical. The chemistry will be different because it's a different steel but the hardenability bands will be essentially the same. An alternate steel on the other hand, may be successful in a given application, but it will be a different hardenability steel. The hardenability that it would have, however, would be adequate for the application. I'm going to remind you of this difference as we proceed and give specific examples.

First though, I am going to talk in terms of substitution in general. I'd like to give a little bit of background on where we've been historically on substitution and a little bit of background about hardenability. This portion won't be "in-depth", just enough to allow us to follow through some of the subsequent reasoning. Fig. 7 is a very significant graph related to substitution. It shows the usage of the alloy steels types that we are considering over a period of seventy years. You can see here starting back in the 1900 era that the straight nickel steels were

very popular. They gave way in popularity to the chrome-vanadium steels, and the nickel-chrome steels. A very significant point on this graph is the area where the nickel-chrome-moly steels became popular. These are 8600 steels that have been the standard of the industry in the types of application we are discussing since the early 1940's. These Ni-Cr-Mo steels are really substitution steels. They were at that time referred to as national emergency, NE, steels. Nickel was in short supply and nickel-bearing steels simply had to be replaced. So this shows we have been successful in this endeavor of making substitutions before. It was quite painful though. The literature of the era says that it was done with a great deal of fear and trepidation. In addition, the implication of this graph is that many of the changes that have occurred have been promoted by catastrophes (e.g.) World War I, World War II and the Korean emergency. All caused changes in the approach to using steels due to a lack of access to certain alloying constituents. We at International Harvester Company have studied this system, seen that it works when it has to, and decided that it could work when least cost was the principal driving force. So we have developed a systematic program which I am going to describe for you that addresses the issue of substitution where least cost is the goal. But before we leave this chart (Fig. 7) I'd like to quickly talk in terms the horizontal axes, the time line, and some of the technologies that allow us to make the substitutions that will be described subsequently; i.e., the technology base. For instance, in the mid 1925's Harry McQuaid did his famous work on grain size. He established a grain size measuring method and demonstrated the

effect of grain size on hardenability. In the early 1930's, Edgar Bain began to unravel some of the intricacies of transformations and we learned a lot more about hardening rationale. In the late 1930's, Walter Jominy developed the end-quench test which is the major tool in use for measuring hardenability. It has been used since that time on a worldwide basis as the criteria for buying and selling steels. During this period also Marcus Grossman developed the basis of our quantitative substitution system. He developed multiplying factors for each individual alloy to enable the calculation of hardenability. Subsequent to that, in the late 40's there was a considerable amount of work building on Grossman's earlier work. For instance, Kramer, Segal and Brooks and others published additional quantitative data. Then there was a dry spell until the late 1950's when Girardi and Jatzak provide multiplying factors for individual elements for high carbon steels and carburizing steels. They pointed out that alloy effects were different at low carbon levels than at high carbon levels for the same alloying element. For instance, if one were trying to calculate expected response in the case portion of a carburized part, he would be very much in error if he only considered base material hardenability factors. Then there wasn't much done till the late 1960's when Doane did some more work on multiplying factors. A considerable number of people, Kirkaldy and others, and ourselves, have developed regression equations to calculate hardenability and then, in addition, our own work in applying a separable computer program to design least cost alloys. This then reviews the background and the way this technology has developed over a long period of time.

I'd like to, before I go any further, bring out one of the major problems related to substitution. To bring it into focus, refer to Fig. 8. I picked up this headline, "Pass the Aspirin: We're changing materials," out of a trade magazine, but it reflects the general attitude in the industry, i.e., the engineering and manufacturing community. Once a material has been proven, the engineer likes to stick with it. He doesn't like to make changes. He will, if that material performs exceptionally well and it develops a warm spot in his heart, even use it in places where it shouldn't be used. His concern is legitimate. He has something that works. The design art is so complex that he just doesn't like to touch things once they are working well. In these days of consumerism, the possibility of product litigation and call backs it's proper to proceed with caution. Handling this attitude will be discussed later.

I would like now to describe a case history of our use of this technology and I am sure, through this experience, you will be able to see how it is applicable to the chromium situation. The system we use is based on the concept that if hardenability remains the same, the same microstructure will result on heat treatment and performance characteristics will be equal. Our system is called the CHAT system (refer Fig. 9), an acronym meaning Computer Harmonized Applications Tailoring, and it is a quantitative system for the design and selection of heat treatable alloy steels. It has two parts. The AT part, Application Tailoring, which I am going to discuss last but I'd like to define first (refer Fig. 10), is a formalized approach used to determine the hardenability levels

required to develop strength gradients required for given applications. That is the system we would use to determine the metallurgical requirements for a given design. The CH portion (Fig. 11), which will be emphasized, is the computer selection of the least cost steel analysis which will meet the minimum hardenability level called for by Application Tailoring. If a part has already been Application Tailored and the hardenability band requirements are set, then one can use the CH process to develop the least cost replacement composition that will have those hardenability characteristics.

Let's review quickly some elementary aspects of hardenability. This is an end-quench bar (Fig. 12). It is heated then quenched on one end to measure hardenability. The dark end is being quenched. So one end is fast cooled and the other slow cooled. After it's completely cooled to room temperature, flats are ground in the longitudinal direction and hardness indentations are made along the length of the bar. The hardness readings are then plotted against distance as is demonstrated in Fig. 13. I want you to keep in mind that many parts made from the steel grades are machined out of low carbon steel and then placed into carburizing furnaces, carbon diffused into the surface and then quenched so that they are in effect two different steels; high carbon on the surface and low carbon in the core. Near the quenched end the steel is harder and then becomes softer towards the slow cooled end. Now, Grossman's work said that this curve in Fig. 13 could be predicted on the basis of multiplying factors for the alloying elements that were involved in the particular piece of steel. He calculated what's called a D_I . We'll not explore D_I

in depth. It's defined as the ideal critical diameter but that's not relevant for our purpose. Let's think of it in terms of an index number for hardenability. Anyway, the D_I is a function of carbon and alloy content and can be calculated using multiplying factors. Referring still to Fig. 13, initial hardness is a function of carbon and the distance hardness is a function of carbon and alloy content. The rapidity of drop off relates to D_I . High D_I 's, high alloy contents are characterized by small changes in hardness with distance and low D_I 's drop off closer in as is shown. Fig. 14 shows two different groups of steels. They're grouped by base carbon level. The higher carbon level will start with a higher surface hardness. A low D_I will drop off faster and a high D_I will be harder farther out on the bar. A lower carbon steel would start at a lower hardness but could have similar D_I . So its hardenability could be the same, i.e., harden to the same distance but have a lower initial hardness and lower distance hardness due to being lower in carbon. The concept I am establishing is that the hardenability of steel can be calculated, not only by this method, but by other methods as well.

Now what we would like to point out though is, that steels are not simple chemistries, but are ranges. They're made day after day as 140 to 240 ton heats and chemistries and hardenabilities vary from heat to heat and within the heat. Mills have agreed, however, on the basis of experience to meet hardenability band specifications. This particular band (refer Fig. 15) is labeled EX 6 but it's the same band as 8622H. EX 6 was one of the early replacement steels we developed and it has exactly the same

hardenability characteristics as 8622 so I am going to use it for my example. Now you can see, taking the mid-range chemistry, that the calculated hardenability splits the band pretty well. But when one takes the chemistry extremes that are allowed, we're inaccurate on both sides of the band. This, of course, relates to the manner in which hardenability bands are established. The principal reason is that the chemistry is seldom all low side or all high side in practice; hence, it's really a statistical problem. We've looked into this area by examining the statistical distribution (refer Fig. 16) of individual alloy elements in a number of heats. We decided to try to calculate the range based on some variation in sigma in this case $\pm 2\sigma$. We recognize though that the variation in $\pm 2\sigma$ chemistry may give different range of multiplying factors depending on what percent of element is involved (refer Fig. 17). I mention this factor as a matter of information. But when we applied ± 2 sigma concepts, we were able to do a fairly reasonable job of calculating the hardenability band for the 8622 and Ex 6 (refer Fig. 18). Now I'd like to point out something here, the D_{IB} for mid-range is 2.3. The D_{IB} , $\pm 2\sigma$, is then 1.6 to 3.1. As yet, we haven't considered the D_{IC} . The D_{IC} is the hardenability at high carbon levels, say .90 carbon. This low carbon steel (.22%) is going to be carburized, so we have to know what the hardenability is at high carbon and D_{IC} 's have to be matched. You might keep that in mind, i.e., there's another curve set like this that represents the D_I in the high carbon region. Just keep in mind the 4.8 from Fig. 18 because it is involved in my example of a replacement steel which was developed during the nickel shortage in 1969. Remember a replacement steel has exactly the same

hardenability characteristics, both case, D_{IC} , and core, D_{IB} . Our objective is to use the principles of CHAT to design a least cost steel with no nickel. I want to describe the CHAT concept in more detail first, however. In CHAT, of course, one of the basic concepts is relative hardenability efficiency, defined as the log of multiplying factor divided by cost. It's simply how much kick in hardenability is involved and how much does it cost. Figs. 19 and 20 are some curves that give relative hardenability efficiencies of some common alloy elements used. You see the manganese is very attractive in terms of low carbon base hardenability, chromium is also, moly and nickel aren't as efficient. If these data were updated with recent changes in price of moly, moly would not look even this attractive. In the high carbon region as you can observe silicon is much more attractive, chrome is even better than manganese at certain levels of alloying element, etc. This is the type of information that's in our computer program. We are in effect saying to the computer, here are the hardenability requirements, give us the chemistry that would provide these hardenabilities, both case and core, at least cost. In this example, Fig. 21, we did just that. At the same time, we restricted Ni. The composition of the new low Ni steel is also shown. It's a little lower chrome, higher moly, significantly higher manganese, but you notice that the D_{IB} is essentially the same, and the D_{IC} , at 4.7 is essentially the same. So you would expect this alloy steel to perform just as well in the applications we had in mind for as the other steel. But the engineering community doesn't agree with this sort of thing. If you assign another number to a steel, to them that's a different steel even though you made

only minor changes. That's where the "Pass the Aspirin" concept comes in. It's really a fixed concept in the minds of most engineers. So we have to do some test work to provide data to show equivalency. I'm going to review for you quickly the results of some test work on this steel. Ex 16, by the way, is also called Equalloy. The EX designation comes from SAE. Before I go into that though, I'd like to show where one can be led astray. We have been talking about D_{IB} and D_{IC} and I told you that Ex 15, Ex 16 type were the same in both case and core hardenability as the steels they replace. I showed you the core hardenability previously, but now here's the results of a test in the high carbon region on this steel compared to 8622H (refer Fig. 22). This demonstrates the similarity in case hardenability to 8622. The other alloy here, Ex 10, has identical base hardenability characteristics as 8622 but significantly different hardenabilities in the high carbon regions. Now this would be a disaster if the requirements on a gear, for instance, was a cooling equivalent of 12/16" on an end-quench test. Only 50 Rockwell would be achieved on the surface in the carburized regions with this steel whereas you would be getting the high hardness you'd expect in Ex 16, giving the high fatigue and wear resistance characteristics, needed for gears. So one has to recognize that both of these characteristics, D_{IB} and D_{IC} , are important. Our motivation as I said has been cost. As you can see (Fig. 23), chromium is a very attractive material for these types of applications. Molybdenum has been changing drastically in cost since 1975. Consequently, we have designed another group of steels with low molybdenum to replace our high tonnage Equalloy applications. Since 1969 we have used these low nickel steels and then recently, the last

couple years, we've switched over to a lower molybdenum type steel referred to as Econalloy. As indicated, cost has been the motivating factor and, believe it or not, these small changes in alloying elements amount to multi-million dollar a year savings in the tonnages we use.

But now I would like to show you some of the information that one has to develop, engineering type information, to convince people that these changes can be made. Referring to Fig. 24, the dotted line regions are the L10 and L90 lines for failure due to profile degradation of gears and the straight lines encapsulate the L10 and L90 for bending failure of gears. This data represents fifteen years of testing of steels like 8620H. This represents how we think the standard performs in terms of torque vs. cycles to failure. So on a new steel like the Equalloy or Ex 15, 16 steels we generate this type of data for comparison. We use a rig like that shown in Fig. 25. It is called a four-square dynamometer. The dotted points in Fig. 24 show then how the new steel performs in comparison to the standard. Another type of test we run is a chassis dynamometer test. Shown in Fig. 26 is a chassis dynamometer. This test simulates the shock loads the rear axle might experience if the vehicle was being "frogged" from a mud hole after being stuck. The performance bogey was 40,000 cycles in this case. The new steel EX 18 was equivalent to if not better than the old steel (refer Fig. 27). Now statistically this approach may be in trouble, but they're equivalent as far as I can see. Fig. 28 shows data from four-square type testing for the new lower moly steels that we're just now introducing. In this instance we tested at two different carbon levels. You can see the performance was very

similar. In addition to evaluating manufacturing characteristics such as machinability and distortion we do vehicle tests at proving grounds and in customer service. This should give a little bit of an idea of what we have to go through to convince the "Pass the Aspirin" group that substitution can be done. We believe, within limits, that the performance will be equivalent if the carbon content, microstructure and residual stress are very close to what was in the parts to be replaced. I'd hasten to add that we're certainly aware that there are limitations. We have been working with low alloys and the changes we're making are relatively small. One of the limitations is that we don't know exactly how large of changes can be made and at what alloy level the alloy per se begins to affect performance. We know that it does take some insight when using the system. Changes shouldn't be made by novices. The areas where we need additional knowledge relate to influence of alloy on fracture toughness and fatigue. We have made fracture toughness evaluations on the steels I just described. For instance, they all, the 8600 and the Equalloy steels have a K_{IC} value in the high carbon region of about 15.5 Ksi square root inches. I'm not sure exactly what that means for a gear, but they're about the same. There's room for research, consequently, one should proceed with caution and be sympathetic with the "Pass the Aspirin" guy and generate the data that's necessary to provide the confidence that allows moving from one steel to another.

Now I've discussed replacement steels, where we talked about having exactly the same hardenability characteristics but with a different chemistry. Now I'd like to touch briefly on the concept of alternate steels. Alternate steels are when a substitution is made with a different hardenability steel but the steel still is adequate for the application. Now what this requires is that some Application Tailoring be done, ATing as we call it. I am going to use as an example hypoid pinions of the type shown in Fig. 29. These are the sophisticated type of rear axle drive gears used in trucks. One of the things that we have to design against for these applications is the possibility of the degradation shown in Fig. 30 happening. In heavy loaded off-highway applications, these gears are stressed quite highly. The thing that causes that type of degradation is the stress gradient along the tooth profile not being supported by enough subsurface strength (refer Fig. 31). So what has to be accomplished is to establish what strength gradient is required, convert that into hardness gradient required and then select the hardenability steel and carburizing combination that will provide that critical strength. We have gone into a considerable amount of study on these gears, including knowing exactly what cooling rates are going to be in production heat treat. This we do by running "mock" carburized samples of different steels of known hardenability and determine what we call Jominy Equivalent Conditions, JEC. After extensive studies, we know that we have to have a minimum of strength gradient as shown here, Fig. 32, for these components. The next step is to take this information and turn that into metallurgical terminology required by the computer (refer Fig. 33). D_{IB} requirements, for

instance, of the base material 3.9 to 6.8 inches. That will give the hardness range required in the core area. The D_{IC} of 6.8 inches minimum will give the hardenability needed to provide the hardness characteristics specified in the high carbon region of the case. This information is placed into the CH part of the computer then the computer program develops the least cost alloy composition (Fig. 34). What I would like to point out (refer Fig. 35) then is that here are base H-bands for two different steels, the new design steels which we call IHRM 20 which will make this part and give us the strength gradient required, and the older steel 4820H, a high nickel steel, that had lower hardenability and lower carbon, would also make the part, but was much more expensive. These steels will both make adequately performing parts but they're entirely different chemistries and different hardenabilities. The new steel chemistry is shown here (refer Fig. 36). This is what the computer provides. Note we're down from $3\frac{1}{2}\%$ nickel to the .20 and .40 nickel level. As a matter of fact, for your interest, noting the molybdenum content here of .25 to .35, we are now designing low molybdenum steel because of the increase in the price of molybdenum. It will be a CH steel since it will have the exact same hardenability, it'll be a replacement steel. We've used this steel for about five years now successfully. Fig. 37 is a summary of what this did for the Company, saved half a million dollars, cut down carburizing time and conserved 90,000 pounds of nickel per year.

That's the end of my story. In summary, I'd like to say I've discussed a technology that with some care in application can develop replacement

steels. If engineers and metallurgists work together they can develop alternate steels. This technology is applicable to the chromium situations. Chromium being a very attractive alloy in terms of hardenability and cost will always be in these types of steel but the restraint can be placed on the computer to keep it out and if one does this it'll end up with steels that are more expensive but they would be least cost without chromium. They would probably contain significant amounts of molybdenum which is available on a domestic basis. I've pointed out that the engineering community, the users of these steels, do not favor making substitutions and that it's necessary to prove up the steels in engineering and manufacturing type tests before they can be accepted.

I thank you for your attention.

IDENTIFIED WORLD CHROMITE ORE RESOURCES¹
(THOUSAND SHORT TONS)

COUNTRY	HIGH Cr, HIGH Fe, & HIGH Al	
	RESERVES	OTHER
WESTERN HEMISPHERE		
UNITED STATES	50	6,100
BRAZIL	6,800	5,750
CANADA	-----	2,900
CUBA	280	1,200
GREENLAND	-----	11,000
OTHER	-----	200
HEMISPHERE TOTAL	7,130	27,150
WORLD TOTAL	1,866,000	2,965,000

¹ ADAPTED FROM US GEOLOGICAL SURVEY, PROF. PAPER 820, 1973

1

IDENTIFIED WORLD CHROMITE ORE RESOURCES¹

COUNTRY	HIGH Cr, HIGH Fe, & HIGH Al	
	RESERVES	OTHER
EASTERN HEMISPHERE		
FINLAND	11,000	5,600
GREECE	100	100
INDIA	7,800	6,700
IRAN	1,700	1,100
MADAGASCAR	5,600	5,600
PHILLIPPINES	5,280	2,760
SOUTHERN RHODESIA	616,000	616,000
SOUTH AFRICA	1,156,000	2,256,000
TURKEY	5,600	5,600
USSR	23,100	24,200
OTHER	2,200	2,200
HEMISPHERE TOTAL	1,834,380	2,925,860
WORLD TOTAL	1,866,000	2,965,000

¹ ADAPTED FROM US GEOLOGICAL SURVEY, PROF. PAPER 820, 1973

2

1978 ALLOY STEEL PRODUCTION

AISI CLASS.	TONS MFG.	ESTIMATED SAE GRADE	Cr RANGE FOR SAE GRADES %	TONS OF Cr REQUIRED
Cr	1,472,913	5000-5100	.70- .90	11,783.3
Cr-V	59,299	6100	.65- .95	474.4
Ni-Cr	137,247	3100-9300	.90-1.25	1,468.5
Ni-Cr-Mo-V	256,091	43BV00	.40- .60	1,280.5
Cr-Mo	2,687,512	4100	.80-1.10	25,531.4
Cr-Mo-V	149,059	SPECIAL STEELS	.60- .90	1,117.9
Ni-Cr-Mo	2,042,176	4300-8600	.45- .65	11,231.9
Si-Mn	176,084	9200	.60- .80	1,232.6
TOTALS	6,980,381 = 66.8%			54,120.5

3



4

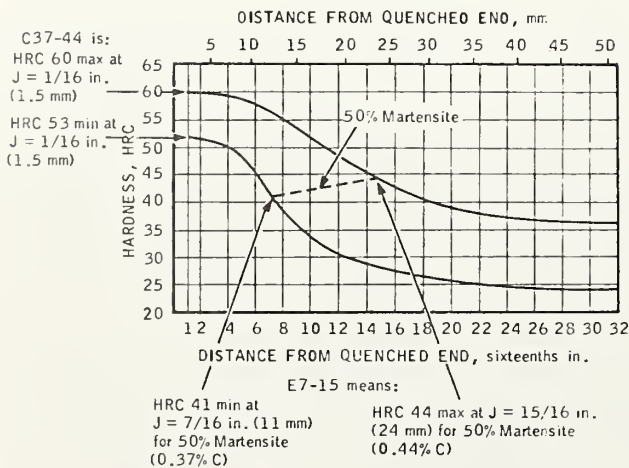

SUBSTITUTION:

- (A) REPLACEMENT
- (B) ALTERNATE

. 8640H hardenability band and classifying system (Sponzilli, Sperry, and Lytell).

5

P7-18

6

HISTORY OF ALLOY STEEL USAGE

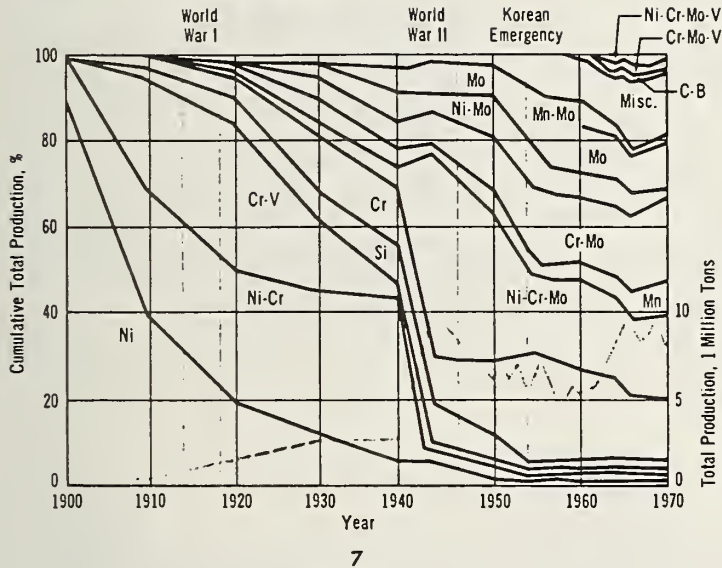

**Pass the Aspirin —
We're Changing Materials**

8

IN CHAT SYSTEM

COMPUTER HARMONIZED APPLICATION TAILORED

Quantitative System
For Design And Selection
Of Heat Treatable Alloy Steels

9

C H A T

APPLICATION TAILORED

A FORMALIZED APPROACH USED TO DETERMINE
THE MINIMUM HARDENABILITY LEVEL REQUIRED
TO PRODUCE THE DESIRED HARDNESS AND
STRENGTH PROPERTIES FOR A GIVEN APPLICATION

10

C H A T

COMPUTER HARMONIZED

COMPUTER SELECTION OF THE LEAST COST
STEEL ANALYSIS WHICH WILL MEET THE
MINIMUM HARDENABILITY LEVEL CALLED FOR
BY APPLICATION TAILORING

11

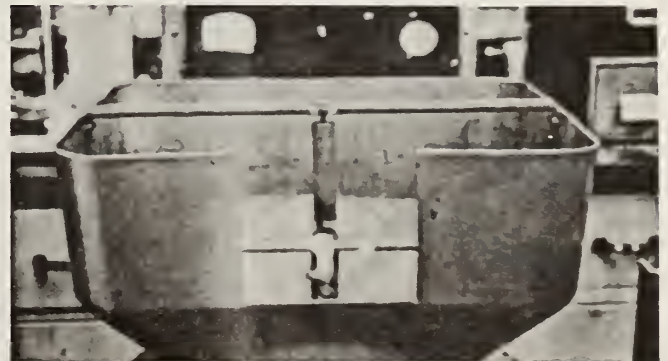

P7-19

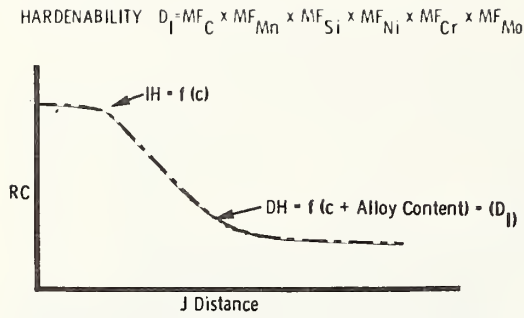

13

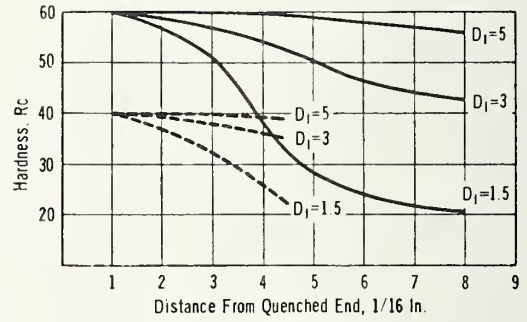

14

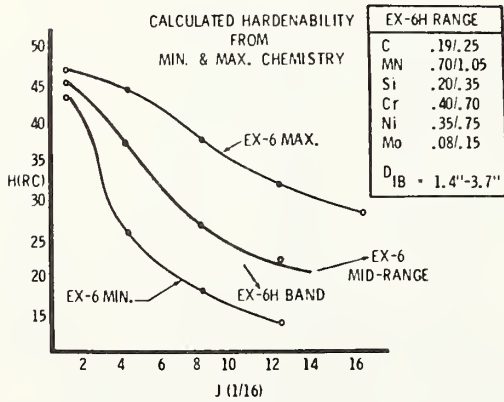

15

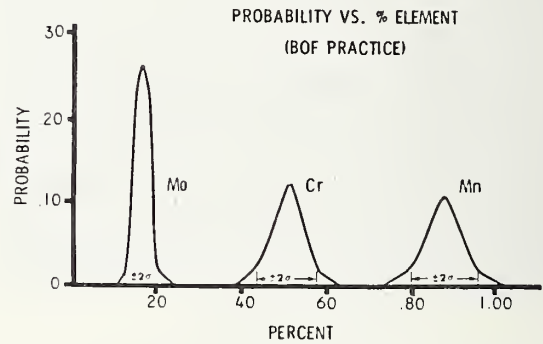

16

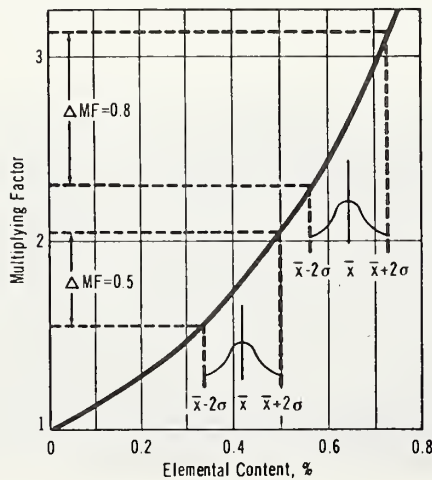

17

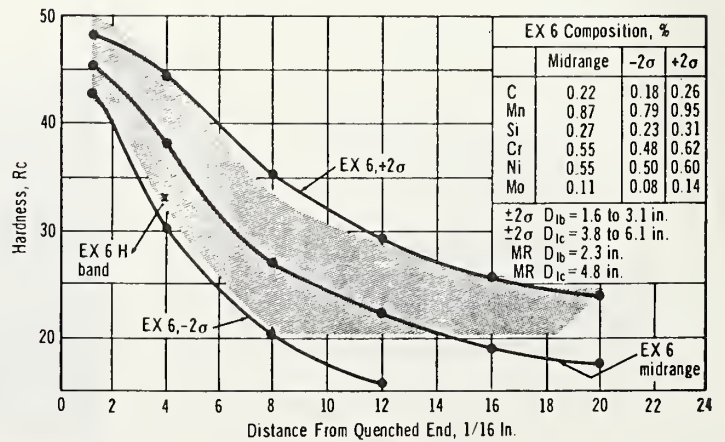

18

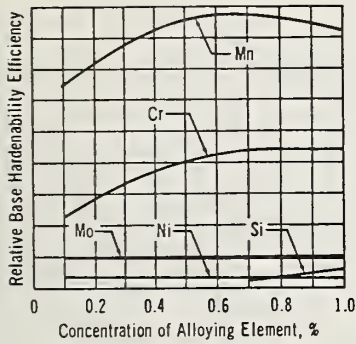

19

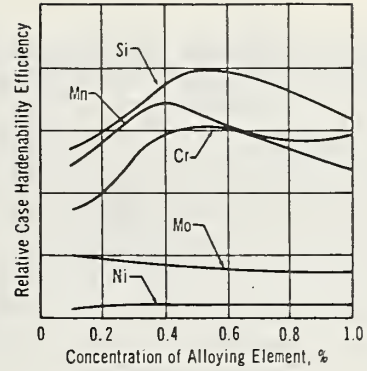

20

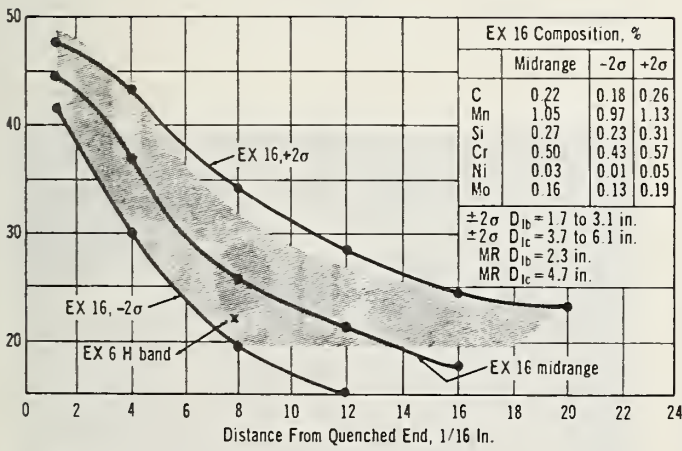

21

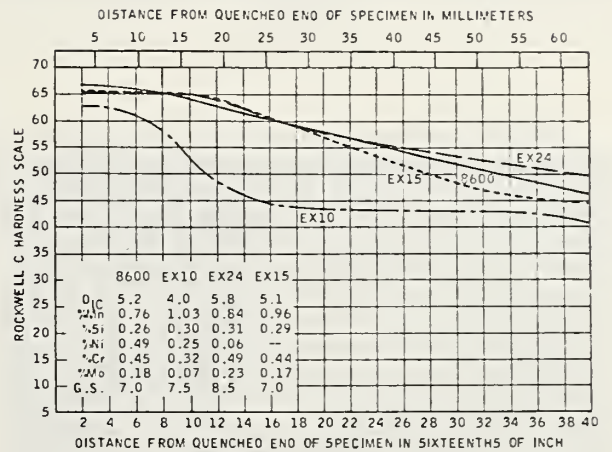

0.90% C case hardenability comparison (low-side chemistry).

22

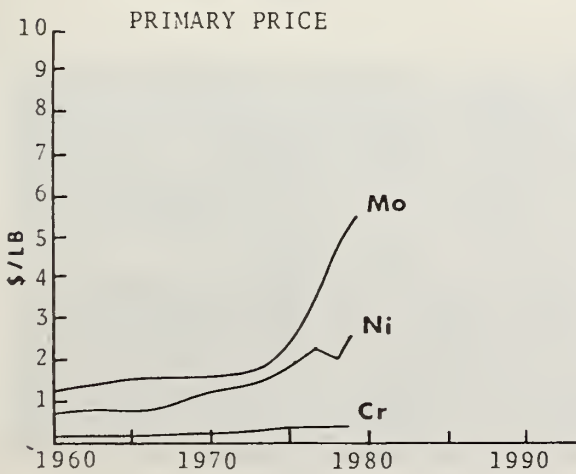

23

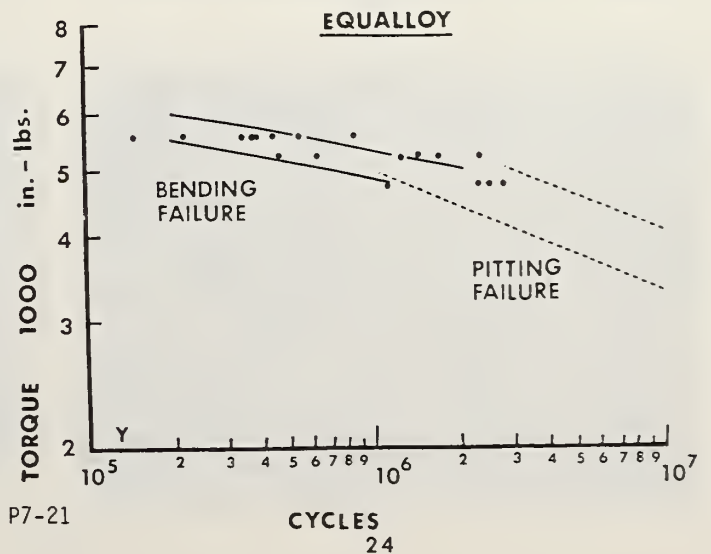

P7-21

EQUALLOY

24

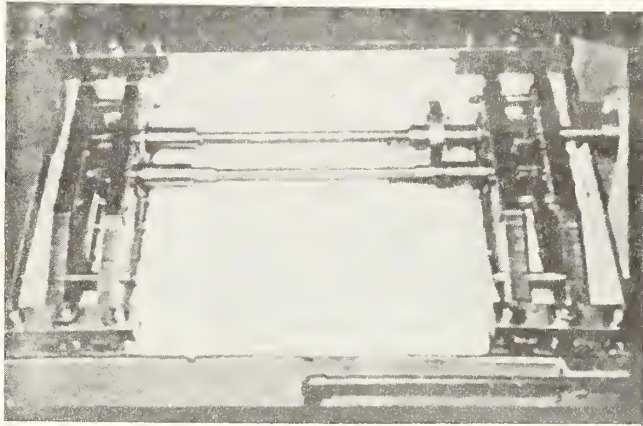

25

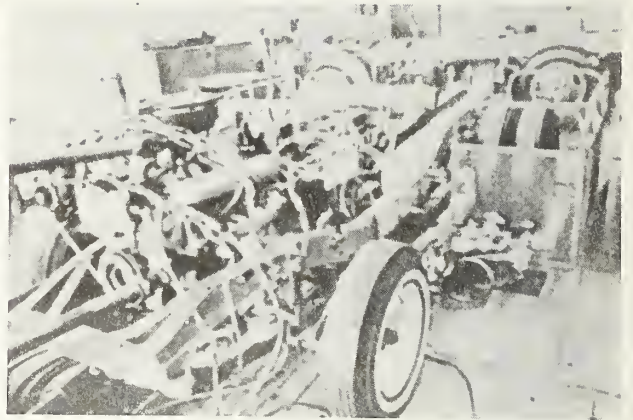

26

PRONY BRAKE DYNAMOMETER TEST OF 18 INCH RING GEAR

TEST IDENTIFICATION	STEEL TYPE	LOAD APPLICATIONS*	GEAR CONDITION	REMARKS
HEAD 1603	EX-18	40 000	ONE TOOTH BROKEN, TWO TEETH CRACKED	POOR RADIUS "BLEND" IN FILLET
HEAD 1604	EX-18	40 000	NO FAILURES	
HEAD 1576	EX-18	35 018	THREE TEETH BROKEN	

*SHAFT IS INERTIA LOADED TO A SHEAR STRESS OF 110 000 PSI

27

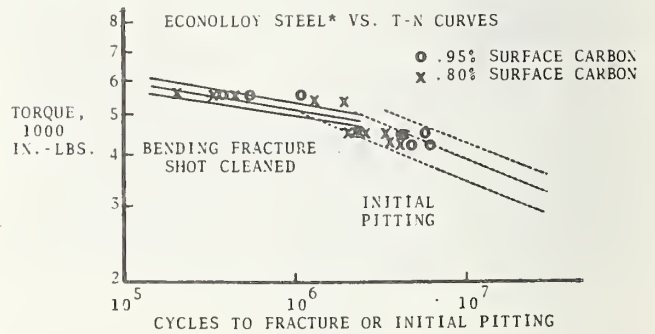

28



29



30

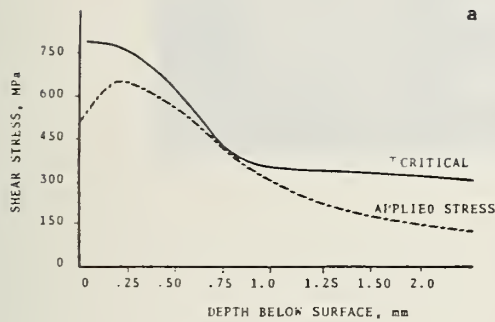

31

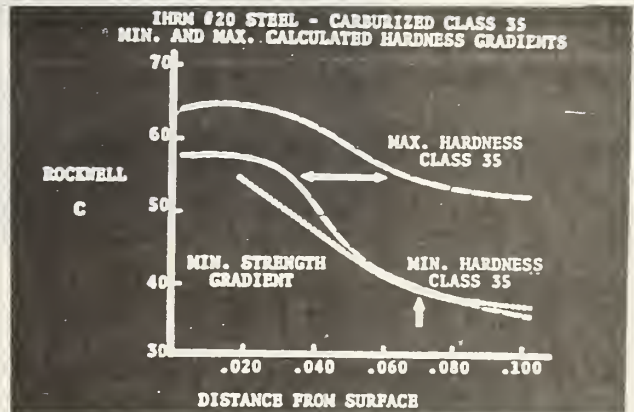

32

AT - APPLICATION TAILORING

- Determine Operational Jec Range
 - Severity and Variability of Quench (J5 - J9)
- Set Base Carbon
 - .26 - .31% Carbon
 - Max. Core Hardness RC 52
- Calculate Hardenability
 - D IB (Core 3.9 - 6.8 inches)
 - D IC (Case 6.8 inches Min.)
- Select Carburizing Cycle
- Check Stress/Strength Compatibility



33

CH - COMPUTER HARMONIZING

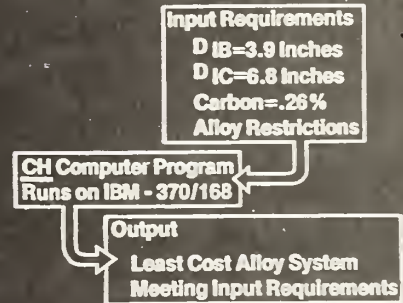

34

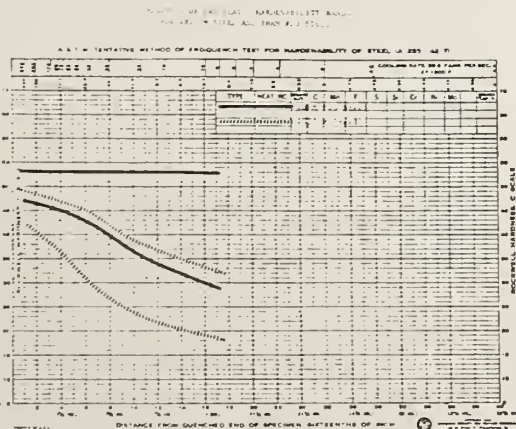

35

OPTIMIZED COMPOSITION

IHRM #20 Research Material

- Carbon .26 - .31%
- Manganese 1.00 - 1.30%
- Sulphur .02 - .04%
- Phosphorus .035% Max.
- Silicon .20 - .35%
- Chromium .90 - 1.35%
- Nickel .20 - .40%
- Molybdenum .25 - .35%

36

SUBSTITUTIONS FOR CHROMIUM IN STEELS FOR COIL SPRINGS

S. T. Furr
Bethlehem Steel Corp.

Laboratory Studies of Low-Chromium and Chromium-Free Steels for Suspension Coil Springs

SUBSTITUTIONS FOR CHROMIUM IN STEELS FOR COIL SPRINGS

S. T. Furr
Bethlehem Steel Corp.
Bethlehem, PA

BECAUSE OF THE CHANGING political conditions in the world, American industry must do its homework well in advance to prepare for the very real possibility that some of the key alloying elements will be even harder to obtain -- and more costly -- than is now the case. Chromium is a good example of an element with potential supply problems, since 90% of the chromium used in this country is imported from South Africa, Turkey and the USSR. If the supply of this important element becomes tight, one of the tasks facing the steel and automotive industries in this country will be to move to spring steels in which chromium can be replaced or reduced in content.

The need to develop a data bank of current information as well as new knowledge about alloy substitution in heat-treatable steels was stressed at a recent congressional hearing by Allen G. Gray, Technical Director of the American Society of Metals (1)*. In addition to

permitting us to step in with substitutes in the event of a tightened supply, such knowledge could provide a spin-off benefit in identifying more-efficient alloys for noncrisis use.

STEELS FOR HOT-FORMED COIL SPRINGS

Over the years a number of alloys have been used for hot-formed coil springs. It will be useful to review these grades since some may be potential substitutes for the chromium-containing grades and others may offer guidance in the design of new alloys. The chemical ranges of the grades of most interest are listed in Table 1. Chromium-containing AISI 5160 (0.70-0.90% Cr) and modified 5160 (0.45-0.65% Cr) are at the top of the list in terms of wide use, followed by three more alloy steels and two carbon steels.

* Numbers in parentheses designate references at end of paper.

ABSTRACT

AISI 5160 and modified 5160, the most commonly used steels for automotive suspension coil springs, contain chromium. In the event this metal becomes hard to get, our industries should have the information basis for introducing spring steels with less or no chromium. This

paper reviews existing spring-steel grades and summarizes a laboratory study aimed at finding new alloys with an optimum combination of properties. New alloy approaches that are potentially competitive with 5160 and modified 5160 during normal times are identified as well as substitutes that could be used during an emergency.

Except for AISI 1095 and AISI 6150, the maximum carbon for these spring steels is about 0.65%, which is apparently considered the safe upper limit for spring steels with good hardenability. Higher carbon will increase the danger of quench cracking for those bars small enough to through-harden.

The third grade listed in Table 1 is AISI 9260, a chromium-free grade containing 1.8-2.2% silicon, that was commonly used for automotive coil springs for many years. In fact, both 9260 and a chromium-vanadium grade, 6150, were recommended in the 1939 edition of the Metals Handbook (2) for use in highly stressed applications. While steels with a large silicon content, as in the case of AISI 9260, have a reputation for excellent load-loss resistance, they may also have relatively poor surface quality, i.e., excessive seams, pits and decarburization (3). To be able to provide satisfactory fatigue life, springs manufactured from as-rolled bars must have good surface quality. Modified 5160 is a successful compromise combining the good load-loss resistance of the silicon steel (9260) with the good surface quality of the chromium steel (5160). The successful development of modified 5160 shows that a silicon addition of about 1% provides good load-loss resistance without impairing surface quality.

Another chromium-free steel was AISI 4068 (4). As compared with 5160 (Table 1), the 4068 grade contains 0.20-0.30% molybdenum rather than chromium.

Although AISI 1095, a carbon steel, is not used for automotive suspension springs, it is the most popular grade for other hot-formed coil-spring applications (5). One reason that alloy rather than carbon steels are recommended for automotive applications is that the alloy steels have better hardenability. Because of low hardenability, quenched and tempered 1095 bars of various sizes show a wide range of yield strengths even though the surface hardness is the same. Alloy steel bars show less scatter since they through-harden. For these reasons, 1095 is satisfactory for coil springs manufactured from small-diameter bars where hardenability is adequate, or for springs manufactured from large-diameter bars operating at low

stress where some hardenability can be safely sacrificed (6).

An example of a successful attempt to increase the hardenability of carbon steel enough for automotive applications is AISI 15B62 (7), Table 1. Increased hardenability is obtained from a relatively high manganese content and a boron addition. AISI 15B62 was successfully used during this decade as a substitute for 5160, and its use was discontinued only because of economic reasons. However, if other alloys for spring steels become less available, AISI 15B62 could again be considered. The technical success of 15B62 demonstrates that the manganese level of spring steels can be at least as high as 1.4%.

The logical next step after this brief review of various spring steels that are or have been on the market is to consider how the requirements for spring steels may change in the future. The most important trend is the decreasing size of automobiles. Spring steels for smaller cars may need less hardenability and more load-loss resistance. The reason for less hardenability is that the bar diameter will continue to decrease as the size of coil springs is scaled down in proportion to the decrease in automobile size.

The need for spring steels with better load-loss resistance could occur as a result of an effort to improve small-car ride characteristics, which are inherently rougher than those of large cars. There are several ways to design a spring to soften the ride. One approach that may be used in the future is to design variable-rate springs (8). The present approach is to decrease the spring rate in constant-rate springs. However, the changes in coil-spring geometry, i.e., larger coil diameter and smaller bar diameter, needed to decrease the spring rate also increase the operating stress and consequently the danger of load loss. The problem of increased load loss due to decreased spring rate was dealt with by adopting the modified 5160 grade in 1977 as a replacement for 5160 in springs with low spring rates. A sagging spring can pose a significant problem by causing the bumper height to fall below the standard height required in federal specifications (9).

TEST PROGRAM

Together with certain directions of interest expressed within the automotive industry, this survey of spring steels provided guidance in formulating the objective and design of our test program.

The test program consisted of comparing 5160 and modified 5160 with other standard

TABLE 1 - Chemical Ranges for Standard Spring Steels

Grade	C	Mn	Si	P	S	B	A
						ppm	ppm
AISI 5160	0.56-0.64	0.75-1.00	0.10-0.40	0.010-0.015	-	-	-
Std 5160	0.58-0.64	0.75-1.00	0.20-1.10	0.010-0.015	-	-	-
AISI 9260	0.56-0.64	0.75-1.00	1.8-2.2	-	-	-	-
AISI 6150	0.48-0.53	0.70-0.90	0.15-0.35	0.005-0.010	-	-	0.1
AISI 4068	0.63-0.70	0.75-1.00	0.10-0.30	-	0.20-0.30	-	-
AISI 1095	0.80-1.03	0.30-0.50	0.00-0.30	-	-	-	-
AISI 15B62	0.53-0.66	1.10-1.40	0.40-0.60	-	-	0.0005	-

grades as well as experimental alloys in order to determine the best alloy-development approaches for the design of low-chromium or chromium-free spring steels.

The most important characteristics required for spring steels are good surface quality for satisfactory fatigue life, good load-loss resistance to avoid sagging, and sufficient hardenability to through-harden the bar and thereby produce a consistently high yield strength. The alloys evaluated and method of analysis are described below.

MATERIALS - The compositions of the bars tested in this program are listed in Table 2. These materials come from a variety of sources. Some were produced from commercial heats and others from laboratory heats. Some were tested during the past year and others ten years ago. For example, the Code at the top of the list, T54, represents bars rolled in 1969 from a 150-lb laboratory induction furnace heat of 15B62. The third alloy, Code C, represents bars rolled from a commercial open hearth heat of 1566 melted in 1977. Some of the experimental heats were fairly large. For example, the F1 and F2 bars were rolled on a commercial bar mill from experimental ten-ton electric furnace heats in 1971. In general, the bars studied in this program were less than 3/4 inch (19 mm) in diameter.

However, experimental bars hot-rolled from experimental heats 01, 02, 05 and 06 were about 1-1/8 inch (29 mm) in diameter.

The first five codes listed in Table 2 are chromium-free carbon steels. AISI 15B62 (Codes T54 and 33) is the only standard spring steel in the group. As compared with 15B62, 1566 (Code C) contains less manganese and silicon and no boron. Codes 01 and 02, which are experimental alloys containing copper, have more manganese than 15B62 but about the same amount of silicon. The primary reason for adding copper to a carbon steel is to obtain improved resistance to atmospheric corrosion. Code 02 actually contains slightly more manganese and silicon than are allowed for a carbon grade. The maximum limits for a carbon steel are 1.65% Mn and 0.60% Si.

The rest of the materials listed in Table 2 are alloy steels. There is a good representation of standard grades -- four samples of 5160, one of 6150, three of 9260, and three of modified 5160. Codes F1 and F2 are experimental 1% Si steels similar in composition to modified 5160, except that the chromium level is reduced from about 0.55 to 0.35%. Code F2 also contains a higher carbon content (0.80%) than is typical for an alloy steel. Codes F and S are experimental alloys containing small chromium and

TABLE 2 - Chemical Composition of Steels Tested in This Program

Code	Grade	C	Mn	P	S	Si	Cr	Al	Other Elements
T54	15B62	0.60	1.20	0.013	0.015	0.53	0.05	0.005	0.003 B
33	15B62	0.60	1.25	0.010	0.021	0.50	0.06	0.041	0.001 B
C	1566	0.60	1.03	0.012	0.026	0.20	0.09	0.027	-
01	Exp.	0.57	1.50	0.017	0.013	0.48	<0.01	0.013	0.25 Cu
02	Exp.	0.66	1.71	0.016	0.013	0.68	<0.01	0.022	0.33 Cu, 0.016 N
53	5160	0.61	0.71	0.013	0.016	0.18	0.77	0.05	-
5	5160	0.66	0.91	0.021	0.027	0.29	0.84	0.035	-
D	5160	0.60	0.92	0.008	0.019	0.36	0.87	0.042	-
A1	5160	0.60	0.79	0.008	0.017	0.23	0.79	0.036	0.05 Mo
18	6150	0.51	0.71	0.007	0.025	0.27	0.95	0.052	0.29 V
54	9260	0.62	0.85	0.005	0.006	2.02	0.08	0.08	-
58	9266	0.68	0.84	0.006	0.005	2.07	0.14	0.03	0.04 Mo, 0.13 Ni
9	9260	0.65	1.00	0.013	0.021	1.87	0.08	0.037	-
A	Mod. 5160	0.61	0.92	0.016	0.015	0.93	0.56	0.040	0.03 Mo
B	Mod. 5160	0.62	0.87	0.015	0.015	0.97	0.54	0.031	-
H	Mod. 5160	0.58	0.90	0.010	0.020	0.95	0.54	0.015	-
F1	Exp.	0.61	0.91	0.009	0.017	0.97	0.35	0.080	-
F2	Exp.	0.80	0.91	0.010	0.015	0.90	0.36	0.036	-
F	Exp.	0.69	1.15	0.012	0.013	0.62	0.12	0.016	0.11 Mo
S	Exp.	0.61	0.88	0.012	0.012	0.99	0.09	0.022	0.05 Mo
05	Exp.	0.67	1.44	0.020	0.019	0.97	<0.01	0.036	-
06	Exp.	0.64	1.55	0.016	0.016	1.11	<0.02	0.040	-
95	Exp.	0.89	1.18	0.017	0.009	1.07	0.04	0.025	-

molybdenum additions. In addition to these elements, Code F contains about 0.60% Si and Code S contains about 1% Si. Codes 05, 06 and 95 are chromium-free alloys also containing about 1% Si. Codes 05 and 06 are 0.65% C alloys with 1.44 and 1.55% Mn, respectively. Code 95 is a 0.89% C alloy with 1.18% Mn.

PROCEDURE - The steels were tested in the laboratory for hardenability and load-loss resistance but not for fatigue life, because results from dynamic tests of laboratory specimens do not necessarily correlate with the results from the dynamic tests of springs. The fatigue life of springs is dependent on the surface quality of the spring round, since the maximum stress is at the surface. Defects and decarburization on the surface of the spring can be traced to steel mill, spring-making processes and testing environment, but a laboratory study cannot duplicate these mill, manufacturing and service conditions. However, since our survey of spring steels had shown that poor surface quality in production is, in most cases, associated with large amounts of silicon, we were able to minimize the potential risk of surface problems by limiting the silicon content of the experimental steels to about 1%.

In the final analysis, the practicality of experimental grades that look promising on the basis of laboratory hardenability and load-loss tests must be proven in actual tests of coil springs and in-service trials.

Hardenability - Hardenability was determined with the Jominy test according to the procedure outlined in SAE J406b. The Jominy specimens were quenched from 1600 F (870 C). Test specimen size depended on bar diameter. If bar diameter was less than one inch (25.4 mm), a one-half size specimen was used. If bar diameter was greater than one inch (25.4 mm), both one-half-size and standard specimens were machined for testing. When available, mill Jominy data from cast specimens were obtained for comparison with laboratory results. The hardenability parameter (J 55) used to compare the various materials is the distance from the quenched end of the Jominy to the position on the bar where the hardness is 55 Rockwell C, i.e., the as-quenched hardness required at the center of a spring round (10).

Load-Loss Resistance - The relative potential load-loss resistance was determined via the Bauschinger torsion test (11). The test specimen, shown in Figure 1, was prepared as follows. Specimens were rough-machined 0.050 inch oversize

out of as-rolled bars. The oversize specimens were austenitized at 1600 F (870 C), then oil-quenched and tempered to 50 Rockwell C, the hardness specified for automotive suspension springs. After oil quenching and tempering, the specimens were ground to size.

Torsion tests were performed on a standard torsion testing machine with a 10,000 in-lb (1130 N-m) capacity. A torsion test is performed by simply twisting the specimen at a relatively slow speed. In this program the rate of twist was 15 degrees per minute. For some of the specimens the shear stress at a three-degree offset was determined from the torque-twist diagrams recorded during testing (12). For a torsion specimen of the dimensions given in Figure 1, a three-degree-offset yield strength in shear is approximately equivalent to the 0.2% offset yield strength in tension.

The Bauschinger torsion test measures the "Bauschinger Effect," i.e., the weakening of metal when it is strained in the reverse direction after a plastic strain in a forward direction. The conventional torsion test reveals the torque-twist diagram, which is a measure of the stress-strain curve of the material in one direction of twist only. For this study we measured the Bauschinger effect using the "actual Bauschinger twist" (ABT), which measures the difference in strain between the forward-twist and reverse-twist curves at 75% of the maximum torque (Figure 2).

Relating Load-Loss Resistance to the Bauschinger Torsion Test - Since springs are energy-storage devices, spring steels must have considerable resilience, i.e., a large energy-storage capacity. Resilience is the ability of a material to recover its original size and shape after deformation caused by stress. The most logical parameter for measuring the resilience of spring steels is the modulus of hyperelastic resilience, because this parameter measures the energy-storage capacity after a preset. Since the final step in spring making is cold setting, the focus is on resilience after plastic strain.

The Bauschinger torsion test serves to predict the potential load-loss resistance of spring steels, since a larger Bauschinger effect means increased hyperelastic resilience, hence improved resistance to load loss. As shown in Figure 3 from our earlier work (11), the better spring steel, 9260, has a larger Bauschinger effect than 5160.

Chishima (13) recently verified the utility of the Bauschinger torsion test. He compared a high-silicon steel, SAE 9254

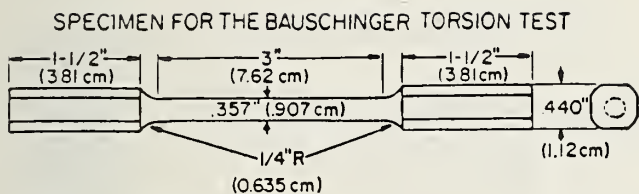

Fig. 1 - Torsion specimen used in the experimental program

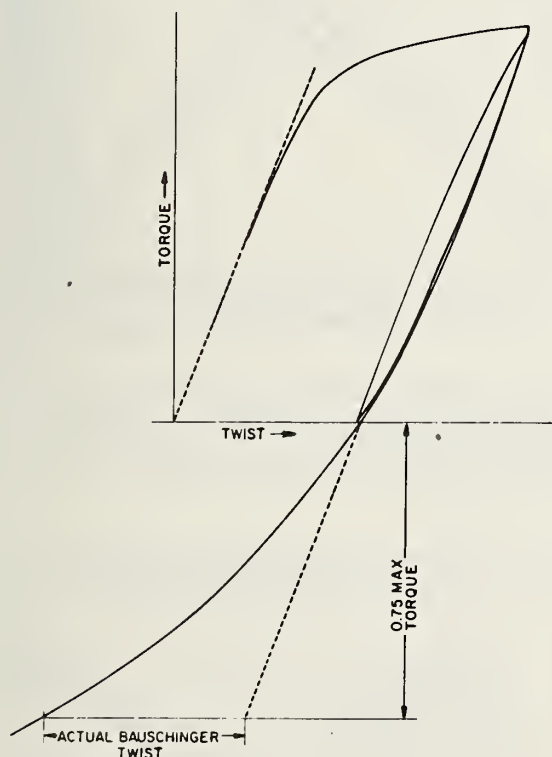

Fig. 2 - Torque-twist diagram showing how the actual Bauschinger twist is defined

(14), and Japanese SUP 9, which is similar to 5160, in the torsion test as well as in static and dynamic tests of coil springs. The 9254, with its larger Bauschinger effect, did indeed show much better load-loss resistance.

RESULTS AND DISCUSSION

THE EFFECT OF COMPOSITION ON LOAD-LOSS RESISTANCE - In Figures 4 to 8 the ABT curves for 5160 and 9260 from Figure 3 are compared with ABT data for modified 5160 and other standard and experimental steels. For all of these steels the Bauschinger effect increases with increasing plastic strain.

ACTUAL BAUSCHINGER TWIST

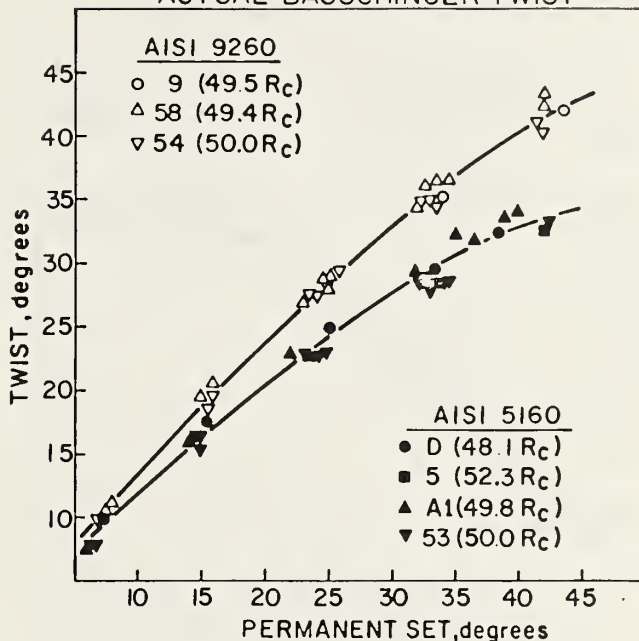

Fig. 3 - Comparison of the Bauschinger effect of AISI 5160 and 9260 spring steels

As shown in Figure 4, the ABT data for modified 5160 fall between the ABT curves for 5160 and 9260. This observation correlates with service experience, since modified 5160 is used in place of 5160 in highly stressed springs susceptible to load loss. The ABT for these standard spring steels increases with increasing silicon content -- 5160 at 0.18-0.36% Si, modified 5160 at 0.93-0.97% Si, and 9260 at 1.87-2.07% Si. The inherent reason for this relationship will be discussed below.

The ABT values for the other steels are grouped according to potential load-loss resistance. For example, alloys compared with 5160 and 9260 in Figure 5 have about the same potential load-loss resistance as 5160. Alloys with larger ABTs and even better potential load-loss resistance are compared in Figures 6 to 8.

The ABT data plotted in Figure 5 were determined for 1566 (Code C), 15862 (Code T54), 6150 (Code 18), and an experimental carbon steel (Code 01). The silicon range of these alloys is 0.18-0.53%, and the carbon range is 0.51-0.63%. Alloys with about the same carbon content have about the same Bauschinger effect as long as the silicon level is fairly low.

Figure 6 gives the ABT for alloys F1, F and 02, similar in carbon content

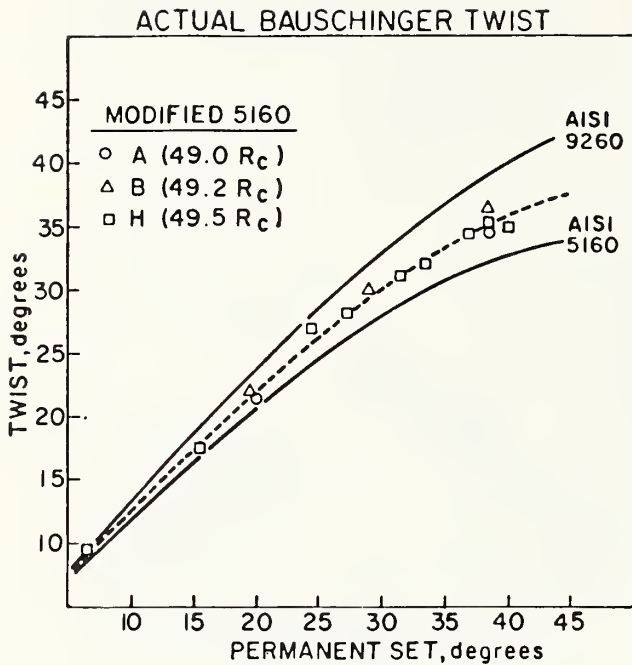

Fig. 4 - Comparison of the 5160 and 9260 actual-Bauschinger-twist (ABT) curves from Fig. 3 with ABT data for modified 5160 steels

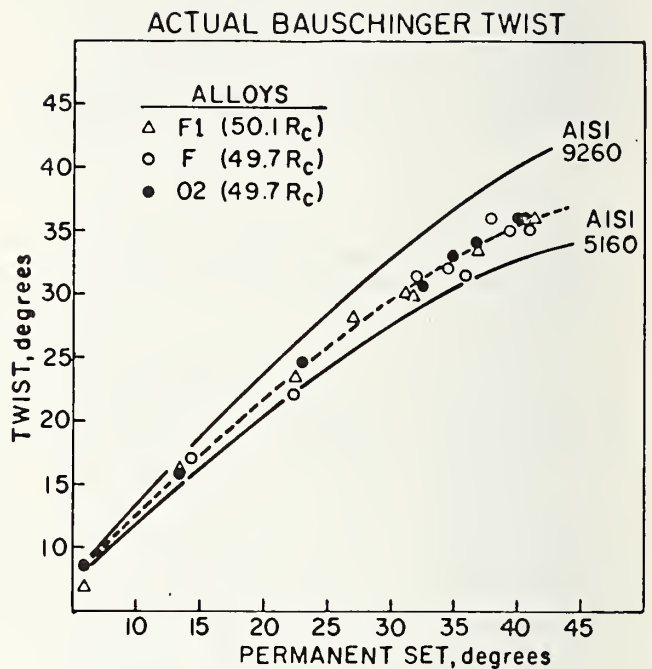

Fig. 6 - Comparison of the 5160 and 9260 ABT curves with ABT data for three alloys with the same potential load-loss resistance as modified 5160 (see Fig. 4)

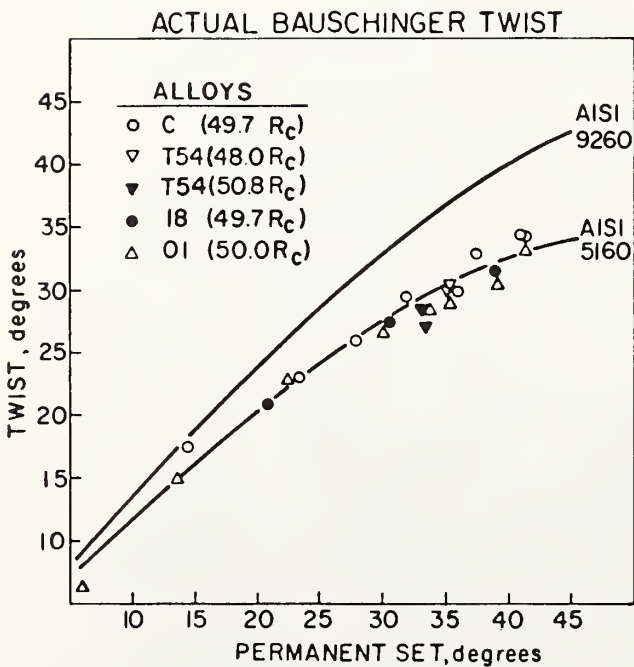

Fig. 5 - Comparison of the 5160 and 9260 ABT curves with ABT data for 1566 (Code C), 15B62 (Code T54), 6150 (Code 18), and an experimental carbon steel (Code O1)

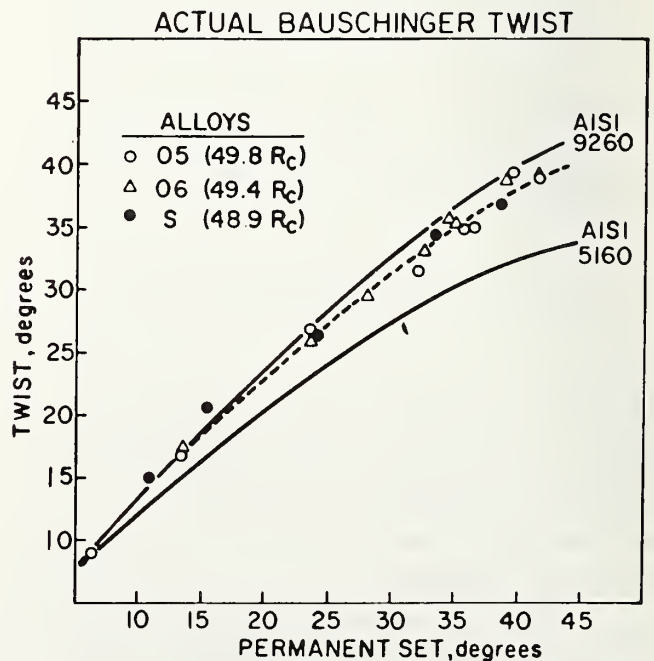

Fig. 7 - Comparison of the 5160 and 9260 ABT curves with ABT data for three alloys with almost the same potential load-loss resistance as 9260

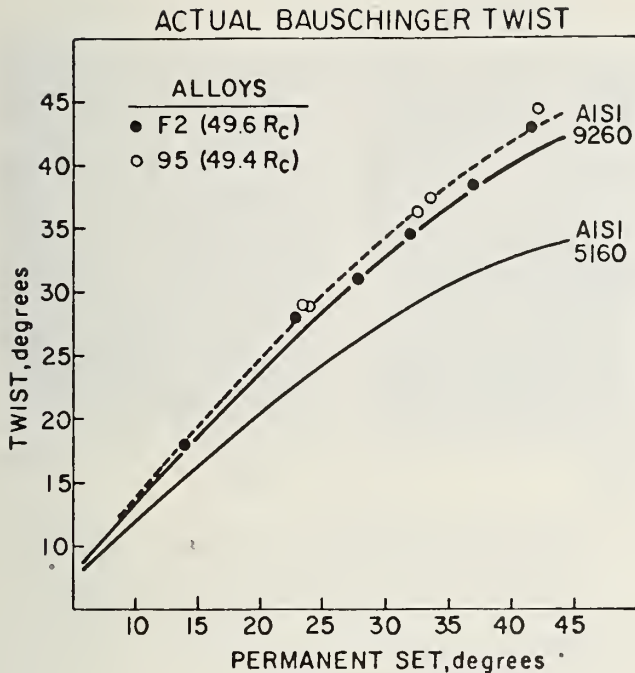

Fig. 8 - Comparison of the 5160 and 9260 ABT curves with ABT data for two alloys with a slightly better potential load-loss resistance than 9260

(0.61-0.69%) to the steels in Figure 5 but with more silicon. Comparing Figures 4 and 6, one sees that these alloys have the same Bauschinger effect as the modified 5160 alloys. The Code F1 and modified 5160 alloys contain about 1% Si and 0.35-0.56% Cr. Codes F and O2 contain 0.62 and 0.68% Si, respectively, and no more than 0.12% Cr. Given the evidence that silicon enhances the Bauschinger effect, the fact that 0.62-0.68% Si steels with little or no chromium have the same ABT as 1% Si steels with chromium indicates that chromium decreases the Bauschinger effect.

The adverse effect of chromium on the potential load-loss resistance of 1% Si steels is confirmed by the data illustrated in Figure 7. Alloys O5, O6 and S, which have the same amount of silicon as in modified 5160 but little or no chromium, exhibit an ABT larger than that for modified 5160 and almost as large as that for 9260, the spring steel with the best load-loss resistance.

According to the data in Figure 8 for codes F2 and 95, another element that increases the Bauschinger effect is carbon. Alloy F2 contains 0.80% C and alloy 95 contains 0.89% C. The ABTs for these experimental steels are actually

slightly larger than that for 9260 (15). The excellent potential load-loss resistance obtained by increasing the carbon content explains, at least in part, the popularity of high-carbon steels such as 1095 for coil-spring applications.

To summarize to this point, the Bauschinger effect increases with increasing plastic strain. In quenched and tempered steels three elements influence the Bauschinger effect. Carbon and silicon increase the Bauschinger effect, but chromium in the range of 0.35-0.56% reduces this effect in 1% Si alloys. Since a larger Bauschinger effect means better load-loss resistance, these results provide the basis for the design of new spring steels.

THE INHERENT CAUSE FOR DIFFERENCES IN THE LOAD-LOSS RESISTANCE OF SPRING STEELS - A simple model (16, 17) can be used to explain the effect of microstructure on the Bauschinger effect and thus account for the positive influence of plastic strain and of carbon and silicon on load-loss resistance. The microstructure of quenched and tempered steels consists of strong, noncoherent cementite particles embedded in a ductile ferrite matrix. If the steel is subjected to plastic strain, dislocations accumulate at the matrix-carbide interface. When the stress in the forward direction causing the strain is released, the dislocations produce micro-residual back stresses in the matrix balanced by larger forward stresses in the carbides. The existence, after plastic strain, of microresidual back stresses in the ferrite matrix of a quenched and tempered steel was demonstrated by Wilson using X-ray diffraction (18).

Such interphase stresses are established in a spring by presetting, the final step in spring making. When the spring is deflected in service (the same direction as the preset), the interphase residual stresses reduce the actual magnitude of the applied stress because the applied and residual stresses are in opposing directions. Consequently, if a coil spring is protected by large interphase microresidual stresses, it will show relatively low load loss in service.

The relative intensity of the interphase residual stresses can be measured with the Bauschinger torsion test. The twist in the forward direction, equivalent to the preset of a spring, produces the back stresses. The twist in the reverse direction reveals the stresses, since microresidual back stresses add to the applied stress to cause yielding at a lower apparent stress than in the forward direction. Thus, with a larger Bauschinger

effect being a measure of a material's ability to develop large microresidual interphase stresses necessary for good load-loss resistance, the Bauschinger torsion test can be used to predict the potential load-loss resistance of spring steels.

The magnitude of the back stresses depends on the number of dislocations accumulated at the carbides and therefore increases with increasing plastic strain and a larger volume fraction of carbides (16). This model explains our results showing that the Bauschinger effect increases with increasing plastic strain and carbon content.

The effect of silicon on back stresses is explained by its effect on carbide size. This alloying element slows down the growth of carbides during tempering by affecting the transformation processes (19,20). According to Fisher's analysis (21), a combination of decreasing carbide size and a larger carbide volume increases the magnitude of the interphase stresses.

We verified that the carbides in a 1% Si steel are finer than the carbides in 5160 by inspecting extraction replicas from samples quenched and tempered to about 50 Rockwell C. As can be seen from the electron micrographs in Figure 9, clouds of small carbides were extracted from the 1% Si steel and relatively large rod-shaped carbides were extracted from 5160. The carbides from both steels were identified as cementite on the basis of X-ray diffraction patterns obtained from a Debye-Scherrer camera. Although both films showed the same diffraction pattern, the films were different in appearance. Because the carbides are smaller, the X-ray film for the 1% Si steel showed fewer lines that tended to be broader and more diffuse (22).

The simple model explained above and supported with metallographic evidence is consistent with the empirical results

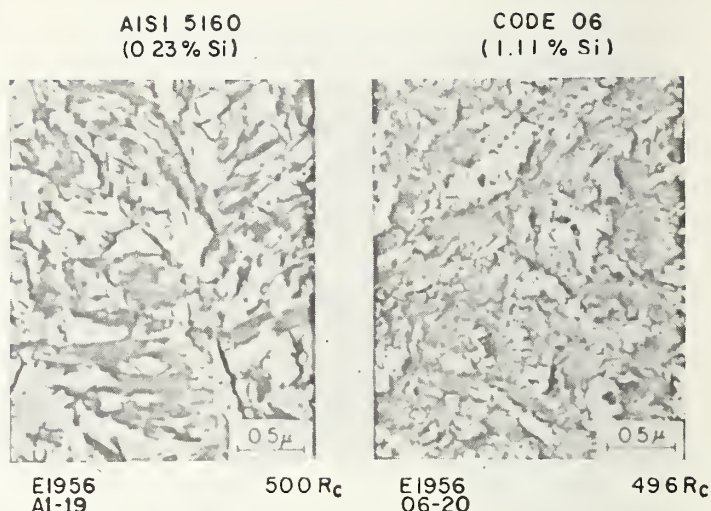

Fig. 9 - Electron micrographs of carbides extracted from 5160 and Code 06. Carbides were extracted with cellulose-acetate replicas from specimens etched for 45 sec. in nital. Original magnification was 30,000X

obtained from the Bauschinger torsion test and with the correlations between the laboratory test and service ratings of spring steels.

HARDENABILITY - The hardenabilities of the most commonly used spring steels, 5160 and modified 5160, are compared in Table 3. The J 55 for these steels was determined from one-half size and standard (cast) specimens. The J 55 for one-half-size specimens tends to be larger than that for standard specimens, because the cooling rate at the same position on the two bars is different (23). However, a comparison of data from either specimen shows that the hardenability of these standard grades is about the same.

The hardenability values of ten alloys with less chromium than 5160 or modified 5160 are shown in Table 4. The alloys are divided into three groups on the basis of

TABLE 3 - Hardenability of AISI 5160 and Mod. 5160

Code	Grade	C	Mn	Si	Cr	Other Elements	J55, 1/16 in (mm)	
							1/2 Size Specimen	Standard Specimen
S	5160	0.66	0.91	0.29	0.84	-	13-1/2 (21)	-
D	5160	0.60	0.92	0.36	0.87	-	11-1/2 (18)	8-1/2 (14) *
Al	5160	0.60	0.79	0.23	0.79	0.05 Mo	13 (21)	-
A	Mod. 5160	0.61	0.92	0.93	0.56	0.03 Mo	22 (35)	>8 (>13) *
B	Mod. 5160	0.62	0.87	0.97	0.54	-	14 (22)	7-1/2 (12) *
H	Mod. 5160	0.58	0.90	0.95	0.54	-	13 (21)	9 (14) *

* Cast

TABLE 4 - Hardenability of Low-Chromium and Chromium-Free Alloys

Code	Grade	Potential Load-Loss Resistance	C	Mn	Si	Cr	Other Elements	J55, 1/16 In (mm)	
								1/2 Size Specimen	Standard Specimen
C	1566	About	0.60	1.03	0.20	0.09	-	3-1/2 (6)	3 (5)*
01	Exp.	Same as	0.57	1.50	0.48	<0.01	0.25 Cu	5-1/2 (9)	5 (8)
33	15B62	5160	0.60	1.25	0.50	0.06	0.001 B	-	8 (13)*
F1	Exp.	About	0.61	0.91	0.97	0.35	-	11-1/2 (18)	-
F	Exp.	Same as	0.69	1.15	0.62	0.12	0.11 Mo	11-1/2 (18)	-
02	Exp.	Mod. 5160	0.66	1.71	0.68	<0.01	0.33 Cu, 0.016 N	14 (22)	11 (18)
S	Exp.	Better	0.61	0.88	0.99	0.09	0.05 Mo	7 (11)	-
05	Exp.	Than	0.67	1.44	0.97	<0.01	-	7-1/2 (12)	6-1/2 (10)
06	Exp.	Mod. 5160	0.64	1.55	1.11	<0.02	-	10-1/2 (17)	8-1/2 (14)
F2	Exp.		0.80	0.91	0.90	0.36	-	11-1/2 (18)	-

* Cast

TABLE 5 - Yield Strength of Carbon and Alloy Steels

Code	Grade	Base	Tempering Temperature F (C)	Hardness Rockwell C	3-deg Offset Yield Strength psi (MPa)
C	1566	Carbon	680 (360)	49.7	127,700 (881)
01	Exp.	Carbon	680 (360)	50.0	131,200 (905)
02	Exp.	Carbon	745 (396)	49.7	128,400 (885)
A1	5160	Alloy	765 (407)	49.8	128,500 (886)
H	Mod. 5160	Alloy	780 (416)	50.4	130,800 (902)
F	Exp.	Alloy	765 (407)	49.7	129,200 (891)
05	Exp.	Alloy	780 (416)	49.8	127,300 (878)
06	Exp.	Alloy	790 (421)	49.4	128,300 (885)

potential load-loss resistance, and within each group are listed in the order of increasing hardenability. For example, the first group consists of three alloys, 1566 (Code C), an experimental alloy (Code 01), and 15B62 (Code 33), that have about the same load-loss resistance as 5160. In the case of 15B62, Code 33 was used to determine hardenability and Code T54 to determine load-loss resistance. The hardenability of 15B62 is better than that of Code 01, which, in turn, has better hardenability than 1566. A comparison of Tables 3 and 4 shows that 15B62 has about the same hardenability as 5160 and modified 5160.

The next group of alloys, Codes F1, F and 02, has about the same potential load-loss resistance as modified 5160. The third group, Codes S, 05, 06 and F2, has even better potential load-loss resistance. The hardenability of these steels is about the same or slightly less than those of the currently used spring steels.

Because the trend in usage is toward spring rounds with smaller diameters, alloys with less hardenability than 5160 and modified 5160 are potential substitutes for these chromium-containing grades.

YIELD STRENGTH - One reason for heat-treating coil springs to high hardness is to obtain high yield strength. As can be seen in Table 5, a number of carbon and alloy steels do not differ significantly from one another in yield strength, when heat treated to about the same surface hardness. Presumably, all of these steels had enough hardenability to through-harden our test specimens.

Yield strength is an important parameter for spring applications, because it is a measure of the modulus of elastic resilience, which is the internal energy to stress the material to the proportional limit. In contrast to the modulus of hyperelastic resilience, which correlates with the Bauschinger effect, the modulus of elastic resilience measures the energy-

storage capacity of a material before plastic strain.

Although high yield strength means high resilience, experience has shown that yield strength cannot by itself rate various spring steels for load-loss resistance. For example, 5160 (Code A1) and modified 5160 (Code H) have the same yield strength but different service ratings (Table 5). Given the problem that ratings cannot be based directly on yield strength data, it is useful it have a method such as the Bauschinger torsion test that can be translated into load-loss resistance.

LOW-CHROMIUM AND CHROMIUM-FREE SPRING STEELS

The selection of replacements for the standard chromium-containing grades depends on the requirements of the spring application and on the availability of chromium. For example, if the supply is short and action must be taken quickly, the most logical substitutes are 15B62 for 5160 and a grade such as F1 for modified 5160 or 5160. The advantage of 15B62 is that it is already a proven grade for automotive suspension coil springs. Our laboratory studies correlate with this service experience by showing that 15B62 (Codes T54 and 33) has the same potential load-loss resistance as 5160 (Figure 5) and about the same hardenability (Tables 3 and 4).

Code F1 is an attractive replacement, because the similarity of its composition to modified 5160 makes it a low-risk substitute. The laboratory work supports this selection by showing that F1, with about 0.2% less Cr, has the same potential load-loss resistance (Figures 4 and 6) and only slightly less hardenability (Tables 3 and 4) than modified 5160.

Chemical ranges of 15B62 as a substitute for 5160, and of a grade based on F1 as a substitute for modified 5160 or 5160 are as follows:

Tabulation A. Ready Substitutes

	<u>C</u>	<u>Mn</u>	<u>Si</u>	<u>Cr</u>	<u>B min</u>
15B62	0.55 0.66	1.10 1.40	0.40 0.60	-	0.0005
F1-Type	0.56 0.64	0.75 1.00	0.70 1.10	0.25 0.40	-

If work on replacement alloys begins while the supply of chromium is still adequate, there will be time to perform actual trials of experimental alloys to find the best new steels. The first step is to decide how much hardenability and

load-loss resistance are needed. The load-loss requirement will depend on the spring design. The amount of hardenability will depend on the size of the round and severity of the quench (10).

Current service experience is a good guide to the amount of load-loss resistance needed. For example, if the load-loss resistance of 5160 is good enough for the application, the best choice for a replacement could be a carbon steel similar to Codes O1 and O2, since these experimental grades have about the same or slightly better potential load-loss resistance than 5160 (Figures 5 and 6). If more load-loss resistance is needed, the best choice could be an alloy steel with about 1% Si, similar to Codes O5 and O6. These alloys have a better potential load-loss resistance than modified 5160 (Figures 4 and 7). The main source of hardenability in these steels is manganese with some help from silicon. Assuming that the maximum possible hardenability is required for the application, the chemical ranges would be as follows:

Tabulation B. Projected Substitutes

	<u>C</u>	<u>Mn</u>	<u>Si</u>	<u>Cu</u>
Carbon	0.57 0.67	1.35 1.65	0.40 0.60	0.20 0.40
Alloy	0.56 0.64	1.30 1.60	0.70 1.10	-

If less hardenability is required, less manganese would be needed.

Although the steels in Tabulation A could quickly move into use if there is a chromium availability problem, those in Tabulation B would, of course, have to be proven in actual tests of coil springs.

ACKNOWLEDGEMENTS

The author would like to thank his colleagues at Bethlehem Steel for many helpful discussions. He is particularly indebted to J. J. McCarthy for the design of the new carbon grade. B. S. Mikofsky's help in manuscript preparation is gratefully acknowledged.

REFERENCES

1. A. G. Gray, "Materials Policy, Research and Development Act of 1979 (H.R. 2743) Including Comments on Substitution Technology for Critical Materials," Testimony at Hearings of Subcommittee on Natural Resources and Environment in Joint Action with the

Subcommittee on Science, Research and Technology of the Committee on Science and Technology of the U.S. House of Representatives, June 28, 1979.

2. Metals Handbook, 1939 Edition, ASM, "Composition and Heat Treatment of Large Helical Springs," pp. 985-986.

3. E. T. Bittner, "Alloy Spring Steels," Trans. ASM, Vol. 40, 1948, pp. 263-280.

4. Metals Handbook, Edited by T. Lyman, 1948 Edition, ASM, "The Composition and Heat Treatment of Steel Springs," pp. 640-647.

5. Metals Handbook, Edited by T. Lyman, Eighth Edition, ASM, Metals Park, Ohio (1961), "Steel Springs," pp. 170-171.

6. Metals Handbook, Edited by B. P. Bardes, Ninth Edition, ASM, Metals Park, Ohio (1978), "Steel Springs," (J. H. Maker), pp. 297-303.

7. R. F. Kern, "Carbon Steel Spring Elements," U.S. Patent 3,689,329 (Sept. 5, 1972). Assigned to Caterpillar Tractor Company.

8. A. R. Solomon, "Coil Spring Design, An Analytical View," Paper 790410 presented at SAE Congress and Exposition, Detroit, March 1979.

9. F. Borik, V. A. Bišs, and Y. E. Smith, "Sag Resistance of Si-Mo and Si-Cr Spring Steels," Paper 790409 presented at SAE Congress and Exposition, Detroit, March 1979.

10. R. F. Kern, "Selecting Steels for Heat-Treated Parts: Part 1 - Direct Hardenable Grades," Metal Progress, Vol. 94, Nov. 1968, pp. 61-73.

11. S. T. Furr, "Development of a New Laboratory Test Method for Spring Steels," Journal of Basic Engineering, ASME Trans. Vol. 94, Series D, 1972, pp. 223-227.

12. G. E. Dieter, "Mechanical Metallurgy," McGraw-Hill, New York (1961), pp. 273-281.

13. K. Chishima, M. Ohhara and K. Uchibori, "On Anti-Creep Property

of High Stress Coil Springs Made of SAE 9254," Paper 10 presented at JSSR (Society of Spring Research of Japan), Osaka, Japan, Nov. 1978.

14. F. P. Zimmerli, Discussion of "An Investigation of Tempered Chromium-Silicon Spring Steel," by H. J. Elmendorf, Trans. ASM, Vol. 40, 1948, pp. 298-299.

15. S. T. Furr, "Helical Spring Steel and Method," U.S. Patent 3,847,678 (Nov. 12, 1974). Assigned to Bethlehem Steel Corporation.

16. R. M. Jamieson and J. E. Hood, "Bauschinger Effect in High-Strength Low-Alloy Steels," Journal of the Iron and Steel Institute, Vol. 209, 1971, pp. 46-48.

17. D. V. Wilson, "Reversible Work Hardening in Alloys of Cubic Metals," Acta Metallurgica, Vol. 13, 1965, pp. 807-814.

18. D. V. Wilson and Y. A. Konnan, "Work Hardening in a Steel Containing a Coarse Dispersion of Cementite Particles," Acta Metallurgica, Vol. 12, 1964, pp. 617-628.

19. J. Gordine and I. Codd, "The Influence of Silicon up to 1.5 wt-% on the Tempering Characteristics of a Spring Steel," Journal of the Iron and Steel Institute, Vol. 207, 1969, pp. 401-407.

20. R. M. Hobbs, G. W. Lorimer and N. Ridley, "Effect of Silicon on the Microstructure of Quenched and Tempered Medium-Carbon Steels," Journal of the Iron and Steel Institute, Vol. 210, 1972, pp. 757-764.

21. J. C. Fisher, E. W. Hart and R. H. Pry, "The Hardening of Metal Crystals by Precipitate Particles," Acta Metallurgica, Vol. 1, 1963, pp. 336-339.

22. B. D. Cullity, "Elements of X-Ray Diffraction," Addison-Wesley, Reading, Massachusetts (1956), pp. 93-99.

23. Isothermal Transformation Diagrams, Third Edition, United States Steel, Pittsburgh, Pennsylvania (1963), pp. 172-173.

AN UPDATE ON FE-MN-AL STEELS AS A REPLACEMENT
FOR NI-CR STAINLESS STEELS

Samir K. Banerji
Foote Mineral Co.

AN UPDATE ON FE-MN-AL STEELS*

Samir K. Banerji
Foote Mineral Co.
Route 100
Exton, PA. 19341

Introduction

An idea was put forth by the author a few years ago to look into the potentials of an Fe-Mn-Al alloy system as a replacement for the austenitic Ni-Cr stainless steels in some non-critical applications (1,2). That generated quite a bit of interest around the world and even sparked some early investigations in some laboratories. Preliminary results from some of these investigations and information from some additional literature which has come to my attention since the publication of my earlier papers (1,2) are summarized here. However, before proceeding to that a brief account of the criticality of the chromium situation is presented to emphasize the relevance of pursuing this idea of developing austenitic stainless steels without chromium and nickel. Although the situation regarding Ni is not so critical, its replacement by Mn is feasible and attractive from an economic and weight-reduction viewpoint.

Criticality of the Chromium Situation

Our vulnerability regarding the chromium situation is well known. A comprehensive review on the "Contingency Plans for Chromium Utilization" has been published by the National Materials Advisory Board (NMAB) of the National Academy of Sciences (3). U.S. is totally dependent on imports for all its chromium needs. About 95% of the world reserves of the chromium ore are located in only two countries: South Africa and Rhodesia (see Table I). The NMAB report cited above (3) states that in the past, U.S. has imported its chromium from several widely separated geographic locations (see Table II) but it is estimated that these secondary sources may soon be exhausted or

*To be presented at Workshop on "Conservation and Substitution Technology for Critical Materials", Nashville, Tennessee, June 15-17, 1981

become insignificant. U.S. chromium deposits are small and virtually no prospects exist for the discovery of any significant new U.S. deposits. There is little evidence to suggest the existence of significant chromium deposits outside of those geographic areas presently known. Therefore, it is feared that at the current rate of consumption, within 25-75 years the world will depend completely on South Africa and Rhodesia. This is an awesome fact and yet we have done very little in terms of substitution, conservation, reclamation and recycling of chromium.

It is obvious that a chromium embargo or a cartel will virtually strangle the nation and pose a grave threat to the national security because "no substitutes exist or are likely to be developed for chromium in the high-strength steels, high-temperature metals, and corrosion-resisting alloys that are essential in the manufacture of jet engines, petrochemical and power plant equipment, and various other critical products (3)". This constitutes about 35% of the total U.S. chromium usage which is essential and, therefore, the remaining 65% of all the chromium used is actually non-essential and replaceable. Figure 1 shows that about 65-70% of the total U.S. chromium use is in metallurgical applications and the remainder being in refractories and chemicals. Table 3 shows the details of Cr consumption under each major use classification and also the possibilities of savings in each application. This Table also shows that it is technically feasible to replace about 26% of the total U.S. chromium use almost immediately and another 40% can be saved after 10 years of research and development. A crash program could obviously accelerate this future potential saving.

As indicated in Table 3 the largest single use of chromium is in stainless and heat-resisting steels, constituting greater than 50% of all chromium consumption in the U.S. Therefore, conservation and substitution of chromium in

this category will provide the maximum savings in terms of tonnage. About 40% of chromium used in these steels is irreplaceable but about 60% of it can be replaced. It is technically feasible to replace about half of that (30%) chromium almost immediately. However, very little has actually been done in this respect. It should be realized by all that in a large number of applications of stainless steels they are "over-designed" for the purpose. This is so because we live in a wasteful society and have been spoiled by the ready availability of chromium so far at a relatively low cost. This plus the outstanding versatility of austenitic stainless steels have made us choose this path of least resistance. Chromium-free or low-chromium substitutes could easily be used in decorative applications, automotive trims, flatware, kitchen utensils, sporting goods, home appliances etc. where traditional high-chromium stainless steels are used unnecessarily. A recent article by Watson(4) states "we could dispense with stainless steel sinks in our homes, and use aluminum in place of stainless steel for our pots and pans. Stainless steel used in dairies, food preparation plants and restaurant kitchens as well as for the transportation of food could be replaced, but not easily or cheaply". Such ideas have to propagate widely and expeditiously. Certainly, no substitution or conservation program is going to be easy or cheap but knowing the criticality of the chromium situation every effort must be made to save any and every ounce of chromium from non-essential applications to direct it toward those essential uses where chromium is absolutely irreplaceable. Table 4 shows the various end uses of stainless steels and the chromium savings possible in each category. Note that chromium-containing stainless steels used in ordnance and accessories, mining, petroleum, natural gas etc. are irreplaceable but in most other categories large fractions of the chromium use can be replaced.

Some of the technologies available for immediate substitution and con-

servation of chromium in stainless and heat-resisting steels are, for example, clad and coated products, replacement of higher Cr steels with existing lower Cr stainless steels in non-critical applications, and using alternate materials such as aluminum, titanium, zinc, copper, brass, plastics etc. wherever possible. As mentioned earlier such measures could immediately save about 30% of the Cr used in stainless steels. The other 30% of the replaceable Cr in stainless and heat-resisting steels will require some research and development efforts as indicated in Table 3. These efforts will include developing chromium-free or low-chromium substitute steels. Again, it must be reiterated that such substitute materials may be good only in non-severe or non-critical applications. It should also be realized that such substitutes may not be as universal and versatile as the present day high chromium stainless steels and one may need to develop specific alloys for specific purposes. The remainder of this paper will deal with one such idea of a chromium-free alloy which appears to have good potentials of replacing austenitic stainless steels in some non-critical applications.

The Fe-Mn-Al Alloys

In previous papers (1,2) it was shown that it is feasible to replace chromium with aluminum, and nickel with manganese and carbon, and yet produce an austenitic alloy, with better mechanical properties than the conventional Ni-Cr austenitic stainless steels. Such alloys can have good oxidation and sulfidation resistance and moderate corrosion resistance. Since the publication of those papers several other references were found in the literature on this subject. These are briefly summarized below.

Summary of Additional Literature on the Fe-Mn-Al System

1) Fe-Mn-Al Precipitation - Hardening Austenitic Alloys by G. L. Kayak (ref.5)

This and the subsequent several Russian papers deal with the "Fermanal"

or 9G28Yu9(0.9%C,28-29%Mn,9%Al) type steels with or without Mo, W, and Cb(Nb) which are about 12-15% lighter than common steels with a density of about 6.7-6.8 g/cm³. They discuss the mechanical and magnetic properties, aging and precipitation kinetics, oxidation and some corrosion resistance of these Fe-Mn-Al steels. This particular paper by Kayak (5) mentions use of these steels in aviation and automotive industries for critical and heavily loaded parts e.g. springs, gears, landing gears etc. He found an optimum composition of 25-30%Mn, 8-10%Al, about 1%C, bal. Fe to get an austenitic structure and good physicochemical properties. Figure 2 shows the mechanical properties of such an alloy as a function of aging temperature. A typical age-hardening peak is observed around 550°C after 16 hours of aging. Increasing the aluminum content and decreasing the manganese and carbon contents results in ferrite phase in the microstructure impairing the plasticity and magnetic properties of the alloy as reflected by permeability studies shown in Table 5. The increased permeability after aging in alloys containing only 23.7%Mn or greater than 10% Al was believed to be due to the precipitation of iron-aluminum carbides and a breakdown of the austenitic structure. The alloys with 28-30% Mn and about 8% Al were completely non-magnetic and austenitic even after aging for 20 hours at 600°C. The oxidation resistance of the alloy was found to depend mainly on the aluminum concentration and very little on the manganese content, which actually impaired it slightly. Alloys with more than 8%Al showed a weight gain of 6-12.5 g/m² in air at 700°C and 500 hours. The 1Kh17N2 (17%Cr, 2%Ni) stainless steel and the 20KhM (Cr-Mo) boiler steel showed weight gains of 6.2 g/m² and 118 g/m², respectively under same conditions. This illustrated the good oxidation resistance of these Fe-Mn-Al alloys.

- 2) Phase Composition, Structure, and Properties of Low-Density Steel 9G28Yu9MVB
by M. F. Alekseenko et. al. (ref.6)

This paper discusses the development of a magnetic method for the quantitative phase analysis of "Fermanal" type alloys in the as-quenched condition and after aging. It was determined that the age-hardening is caused by the precipitation of a complex carbide of the $(\text{Fe,Mn})_3\text{AlC}_x$ type. This is consistent with the work of James (7) who used electrolytic extraction and x-ray diffraction techniques for the identification of this phase. The amount of this hardening phase was maximum at about 550°C aging temperature resulting in a peak hardness (Fig. 3) and strength (5) and minimum ductility (Fig. 2, ref. 5) and impact strength, Fig. 3. Above this aging temperature they believed that the $(\text{Fe,Mn})_3\text{AlC}_x$ phase starts to dissolve causing the strength to drop and ductility to increase. However, the toughness may or may not recover because it depends not only on the amount of the hardening phase but also on the grain size and the presence and size of precipitates at the grain boundaries. Based on this study these authors recommended that for optimum mechanical properties the Al content of the alloy should be limited to a maximum of 9.2% with carbon not exceeding 0.92% and a fine-grained fully austenitic structure should be obtained after quenching.

The work of James (7) on a Fe-9Al-9.5Mn-0.96C-6.77Ni alloy also showed similar precipitation of a mixed carbide phase $(\text{FeMn})_3\text{AlC}$ with a cubic structure. This precipitation occurred in a cellular form at austenite grain boundaries as well as twin boundaries. The peak hardening in this case occurred at about 600°C aging temperature in both the as-rolled and solution treated condition, Fig. 4a. Kinetically, a sharp increase in hardness occurred after only 15 minutes of aging with the peak hardness achieved in 2 hours for the as-rolled material compared to 4 hours in the solution-annealed condition, Fig. 4b. This alloy showed a severe embrittlement as a result of aging and the gain in strength was offset by the loss in ductility and toughness.

3) Phase Transformation Kinetics in Steel 9G28Yu9MVB by G. S. Krivonogov et. al. (ref.8)

This paper takes a deeper look into the kinetics of austenite decomposition in these steels as a result of aging over a wide range of time and temperature. Quantitative magnetic methods for phase analysis, electron microscopy and x-ray crystallography are used to show that the decomposition of the as-quenched austenite occurs in two stages upon aging. The first step (at aging temperatures below 700°C) involves the precipitation of a finely dispersed coherent K-phase at $450\text{--}550^{\circ}\text{C}$ which has an ordered f.c.c. structure with $\text{Fe}_3\text{AlC}_{0.66}$ composition and is oriented in the $\langle 100 \rangle$ crystallographic direction. This is the dispersion hardening phase which can be used to achieve the required combination of mechanical properties with the matrix still being austenite. With increasing aging temperature these K-phase particles grow, their number density drops, and their coherency with the matrix is lost. Above 650°C large K-phase precipitates are observed only at the grain boundaries. The second stage occurs around $650\text{--}750^{\circ}\text{C}$ when the austenite which is now depleted in carbon and aluminum and rich in manganese breaks down into ferrite and a brittle beta-manganese phase. The K-phase is simultaneously enriched in Mn and C by redistribution of the alloying elements and can contain up to 15-25%Mn after prolonged aging at $650\text{--}750^{\circ}\text{C}$. This is the $(\text{FeMn})_3\text{AlC}_x$ phase mentioned earlier (6). At aging temperatures of $750\text{--}850^{\circ}\text{C}$ this precipitate forms in the first stage of decomposition. In the second stage, the beta-manganese is not formed at these temperatures, instead more of the $(\text{FeMn})_3\text{AlC}_x$ phase precipitates and austenite transforms to ferrite rich in Mn and Al. Prior plastic deformation of the austenite substantially accelerates the second stage. Plastic deformation after aging destroys the ordered structure of the carbide phase and this type of treatment can be used to produce ultra-high-strength sheets with tensile strength of $170\text{--}180 \text{ Kg/mm}^2$.

4) Structural and Phase Changes in Steel 9G28Yu9MVB During Aging by L. I. Lysak

et. al. (ref.9)

This is practically the same paper as ref.(8). It again shows the age-hardening peak around 550°C being related to the amount of finely dispersed coherent K-phase. The loss in coherency, growth, and reduced number of these precipitates explains the decrease in hardness and strength at higher aging temperatures. Plastic deformation of the quenched austenite again accelerates the kinetics of aging.

5) Nature of Age Toughening of Fe-Mn-Al-C Alloys by N. A. Storchak and A. G. Drachinskaya (ref.10)

This is again a very similar paper to references (8) and (9). The same observations were confirmed by x-ray diffraction methods using single crystals of the 9G28Yu9MVB steel grown by the recrystallization annealing method at 1000-1100°C.

6) State of the Surface Layer and Corrosion Resistance of Steel 9G28Yu9MVB by V. P. Batrakov et. al. (ref.11)

First, the mechanical properties of the cold-rolled sheets, and quenched (from 1050°C) and aged (at 500-600°C for 10-20 hrs.) bars of this steel are provided. At normal test temperatures the cold-rolled sheets (50% reduction) have a tensile strength of 140-150 Kg/mm², 0.2% yield strength of 130-140 Kg/mm² with 10-12% elongation. The bars have a tensile strength of 110-120 Kg/mm², 0.2% yield strength of 100-105 Kg/mm², 35% elongation, 55% reduction in area and impact toughness, $A_H=7-9$ Kgm/cm². The stress-rupture strength, $\sigma_{100}^{500} \sim 70$ Kgm/cm² is reported. The use of this steel at temperatures up to 500°C is recommended.

The general corrosion behavior was measured in wet, tropical, and salt mist atmospheres. Specimens were degreased, etched, and passivated before placing them in the test chamber. The wet chamber was maintained at 20-25°C and 95-98% relative humidity. The tropical atmosphere test comprised of holding

for 8 hours at 50°C and 95-98% relative humidity, 12 hours at 20+5°C and 95-98% humidity, and 4 hours at 20+5°C and air purging. The salt mist chamber was held at 20-25°C with 95-98% relative humidity and periodic spray of a 3% NaCl solution. Maximum corrosion occurred in the salt mist environment. The practice of iron shot blasting to remove the scale after hot rolling and quenching before cold rolling displayed friable corrosion products at the points of impingement after only 7 days. In this condition the steel showed an unacceptably high corrosion rate (5-10mm/yr.).

Elimination of shot blasting, and deep chemical etching to a depth of 100-300 μ to remove the scale in hot rolled and quenched sheets provides satisfactory corrosion rates (0.01-0.1mm/yr.) after cold rolling and passivation. Examination of the surface layer formed in this steel when it is exposed to high temperatures revealed the reasons for this corrosion behavior. Electron microprobe analysis revealed a ferritic surface layer depleted in Mn and Al by factors of 4 and 2, respectively compared to the bulk composition when the steel is exposed at 1100°C for 1 hour. The thickness of this outer layer is about 20-25 microns under these conditions, Fig. 5. Metallographic and magnetometric studies confirmed this outer layer to be ferritic and also showed that this ferrite phase actually extends deep into the metal along the austenite grain boundaries. Figure 6 shows a plot of the depth of penetration of ferrite at the grain boundaries from the metal surface as a function of time at three different exposure temperatures, determined by metallographic and saturation magnetization ($4\pi I_s$) methods. Note that the depth of the two-phase layer actually extends as deep as 350-400 microns after 1 hour exposure at 1100°C or about 500 microns at 1150°C. The total ferrite content of the specimen does not exceed 6-8% as estimated from the saturation magnetization. Therefore, satisfactory corrosion resistance is attainable only if the two-

phase layer is removed completely, otherwise pitting corrosion occurs where the ferritic grain boundaries intersect the outer surface.

For best results the scale and the two-phase surface layer of the hot rolled and quenched steel should be etched away in 20% HNO_3 at room temperature for 30-40 minutes or by 40% KOH + 2% potassium permanganate at 120°C for 1-2 hours followed by 5 minutes in 20% HNO_3 at room temperature. After cold rolling the steel should be pickled and passivated in a solution of CrO_3 (150 g/liter) + H_3PO_4 (100 ml/liter). For more severe environments further protection against corrosion can be achieved by depositing paint and varnish coatings on specially prepared surface which can be attained by galvanic or phosphate coating, or metal spraying with aluminum. For zinc or cadmium galvanic coating the surface can be prepared by etching in 20% HNO_3 for 2-3 minutes followed by chemical degreasing and pickling in 4-5% solution of orthophosphoric acid for 30-90 seconds. Such systems of paint and varnish coatings based on epoxy-polyamide or silicone enamels, combined with phosphating or spraying with aluminum ensure protection from corrosions at operating temperatures up to 500°C . Again, it is emphasized that for good adhesion of paint and varnish coatings it is essential to remove the two-phase surface layer completely.

One very interesting feature of this steel is that it was found to be not susceptible to stress corrosion cracking. Pure bend specimens stressed to 80% of the yield stress were tested in the salt mist and tropical chambers. Some specimens were only degreased and others were degreased, etched, and passivated. No effect of stress on the overall corrosion was observed. Despite the presence of pitting, no stress corrosion cracking was detected after 90 days of testing in these atmospheres.

7) Aluminum-Manganese-Iron Alloys by R. E. Cairns, Jr. and J. L. Ham, ref. (12)

This 1963 patent is a much detailed work along the lines reported earlier

by the authors (13) and referenced in my previous papers (1,2). The principal objective of this invention was to provide low density, oxidation resistant, cold-ductile austenitic alloys from non-strategic materials having good mechanical properties at room and elevated (1200°F) temperatures. It was also the object of this work to achieve good workability so that the alloys can be fabricated by normal steel processing techniques. These properties were satisfactorily achieved in the patented alloys with following composition: 20-40%Mn, 7-16%Al, 0.15-1.1%C, 0-10%Ni, and bal. substantially iron. The forgeability of these alloys are reported to be very good and a wide temperature range of 2000-2300°F could be used without harmful effects. The machinability of the alloys containing more than 15% austenite was comparable to normal stainless steels. The composition of some specific alloys, the percentage of austenite in those alloys, and their mechanical properties at room temperature and 1200 F after different heat treatments are shown in Table 6. The improvement in room temperature ductility with increasing austenite content in the alloy is clearly shown in Fig. 7.

The density of these alloys are approximately 15% lower than those of common stainless steels and much lower than those of high temperature super-alloys. The oxidation resistance of these alloys in general are quite good as shown in Table 7 and compared with a stainless steel (310), a cobalt-base alloy (S-816), and a nickel base alloy (Udimet 500). Note that increasing Mn content does impair the oxidation resistance of the alloy somewhat. In cold rolling no difficulty was encountered in 80-100% austenitic alloys and normal steel processing techniques could be used. 80% cold reduction was achieved with 20% per pass. The alloy containing 40% austenite could be cold reduced 66% using the above schedule. The strain-aging characteristics of these alloys were shown by annealing the cold rolled sheets (0.1") for 1 hour in the temper-

ature range 700 -1000°C after different degrees of cold reduction. A minimum of about 20% cold reduction is necessary to observe the strain-age-hardening phenomenon which occurs around 700°C annealing temperature, for example, see Fig. 8 for alloy #213 containing 10.2%Al, 34.4%Mn and 0.76%C. Therefore, the mechanical properties shown in Table 6 really reflect the solution-annealed properties and not the maximum attainable values.

8) Iron Aluminum Alloys by W. H. Richardson (ref.14)

This 1965 patent describes a family of Fe-Mn-Al alloys very similar to those patented by Cairns and Ham (12). The object here being the development of alloys possessing good ductility, high strength, corrosion resistance and low density, combined with high electrical resistivity and low magnetic permeability. The range of composition of these alloys are: 18-40%Mn, 4-14%Al, 0.15-2%C, with at least one of the following additional elements 0.5-12%W, 0.1-5%Mo, 0.5-15%Ni, 0.5-5%Co, 0.1-2%Cb, 0.5-15.9%Cr, up to 5%Ti, Cu, V, or Zr, or up to 1% B or Ce, up to 1.5% impurities (P,S,Si), the balance being iron. These alloys can be produced by the conventional electric furnace steelmaking methods or by induction melting. Both continuous casting or conventional ingot casting can be used. The "Durville" casting process gave excellent result. The preferred soaking temperature of ingots or billets prior to hot working is recommended to be 1100^o-1200^oC for one-half hour per inch of thickness or cross sectional area. They can then be hot worked satisfactorily by any of the conventional hot working processes such as rolling, forging or extruding. Table 8 shows the various alloys used in this work. The mechanical properties of hot-rolled (from 1100-1200^oC) bars were measured. The ductility and impact properties could be improved considerably by a solution-annealing treatment at 800^o-1250^oC after hot rolling. Alternatively, similar improvement in properties could be achieved by finishing the hot working operation in the solution

annealing temperature range and then quenching from that temperature, thus, eliminating the need for subsequent solution anneal. Further hardening can be produced by aging at 400-700°C and any combination of strength and toughness properties can be achieved by adjusting the time and temperature of aging.

The solution annealed (at 800-1250°C) and quenched alloys are amenable to cold working and tensile strengths higher than 200,000 psi are achievable after 40-50% cold reduction. The cold rolled materials also respond to strain-age hardening in the temperature range of 400°-700°C. In this conditions, hardness values as high as 600-700 V.P.N. may be achieved making the alloys suitable for severe wear and abrasion resistant applications. Intermittent corrosion tests in 5% NaCl solution showed a corrosion rate of 49.8 mg/cm²/day in a 15 day test for an Fe-8.6Al-19.7Mn-1.02C alloy. A 7 day test on an Fe-6.1Al-30.6Mn-0.56C alloy showed a corrosion rate of 60.1 mg/cm²/day. Addition of Cr and/or Ni to such alloys reduced the corrosion rates by about an order of magnitude. Alloys of this invention containing less than 7%Al are not susceptible to embrittlement during prolonged aging at 500-600°C and they also possess very good impact properties at sub-zero temperatures.

These alloys could be modified by adding some Ni and dropping the Mn but still maintaining the predominantly austenitic structure. Such modified alloys could contain 4-14%Al, 8-18%Mn, 3-15%Ni, 0.6-1.2%C, bal. Fe. The mechanical properties and heat treatment response of these Ni-modified, low-Mn steels are quite similar to the Ni-free, high-Mn steels described above. All these steels are predominantly austenitic but may contain a small amount of ferrite depending on processing and heat treatment condition. Consequently, they are essentially non-magnetisable alloys even though they may be weakly attracted by a magnet under certain conditions.

9) New Cryogenic Materials: Fe-Mn-Al Alloys by J. Charles et. al., ref.(15)

This latest paper on this subject has investigated the mechanical properties of these alloys at liquid nitrogen (-196°C or -320°F) temperature as well as at room temperature. The base alloy studied was Fe-30Mn-5Al with increasing amounts of carbon and silicon. They observed a high degree of dendritic segregation or coring in the small ingots weighing only 2.6 lbs. Special thermomechanical treatments were used for mechanical working of these small ingots which involved 33% cold reduction, homogenization at 1150°C for 48 hours, another 33% cold reduction, recrystallization at 925°C for 25 minutes. An ASTM grain size of 4 was achieved this way. The effect of carbon on the mechanical properties at both room temperature and -196°C are shown in Fig. 9. The low temperature properties are excellent with impact strengths of more than 32 ft-lb./in². Another set of alloys containing Fe-30Mn-5Al-0.3C with increasing amounts of Si showed the important hardening effect of Si at both room temperature and -196°C , Fig. 10, with no loss in ductility or toughness. The exceptionally high low temperature ductility and toughness of these Fe-Mn-Al steels down to -196°C make them very attractive candidates for cryogenic applications such as liquified natural gas containers, pipelines etc.

10) Mn-Al Steel Developed by Ford Motor Co., (ref.16)

A very brief mention of this work exists in the 10th edition of Materials Handbook. The steel composition was 30%Mn, 9%Al, 1%Si, 1%C and had a tensile strength of 120 ksi with 18% elongation. It work hardened rapidly and the cold-rolled material responded to strain-aging to achieve a tensile strength of 300 ksi and yield strength of 290 ksi. The alloy was reported to have high resistance to oxidation and sulfur gases up to 1400°F .

11) U.S. Seeking New Kinds of Stainless Steels - by P. Weintraub, ref. (17)

This report appeared in the American Metal Market/Metal Working News about

one and a half years ago. Apparently there is some work sponsored by the U.S. Bureau of Mines currently in progress at the Massachusetts Institute of Technology to use the huge amounts of Mn nodules found at the ocean beds and develop manganese-base alloys which might replace "chromium-laden" steels. These alloys could contain up to 40%Mn, 10%Al, balance Fe. They could contain some chromium for more corrosive environments. The report says "it's possible that experiments will reveal the use of chrome has been more or less habitual rather than necessary in a large number of cases". This point has been emphasized earlier. Yet, the feeling regarding Cr-substitution in many circles is that of "waste of time and money" and "not do-able". The same feeling prevails in the steel industry which has "no great impetus for activity" in this vitally important area because they "see no imminent shortage of chromium on the horizon". Personally, this attitude is simply appalling to me. The article ends in a message which needs to be repeated over and over again: "nobody wants to depend upon new and expensive technology . . . but we would rather rely on new technology than a foreign supply of chrome".

Some Low-Chromium Substitutes

In addition to developing totally new chromium-free materials such as those described above, the possibilities of reducing the chromium content of existing stainless steels are also promising. NASA-Lewis Research Center performed some work on reducing the chromium content of 304 stainless steel which is the largest single stainless steel grade in use comprising over 30% of all the stainless steel consumed in the U.S.(18). A minimum of 12% Cr was found to be necessary to retain the corrosion and oxidation resistance comparable to 304SS. Some of the alloys explored in this study are shown in Table 9. The last two austenitic alloys shown in this table exhibited

oxidation resistance comparable to 304SS in high temperature (870°C or 1600°F) cyclic oxidation tests, Fig. 11. Tests in copper sulfate-sulfuric acid solution show that the corrosion resistance of these alloys is also comparable to the standard 304SS. To compensate for the reduced chromium content, 3.65%Si in one of these alloys and 2% each of Al and Mo in the other were added. The presence of these ferrite forming elements necessitated an increase in the Ni content of these alloys to 10% and also an addition of 5.1%Mn in the Al-Mo modified steel. The tensile properties of these alloys in the temperature range of -321° to 1000°F were also comparable to the commercial 304SS. Although these alloy compositions are not fully optimized yet, they clearly represent the potential of 33% savings of chromium in currently used 304 stainless steels. These low chromium modifications of 304SS could be used successfully in heat exchangers, chemical process equipments, cryogenic containers, automobile trims and a large variety of other applications where stainless steels are currently used.

Another family of stainless steels based on the Fe-Mn-Al-Cr system have apparently been developed on a laboratory scale at Fulmer Research Institute Limited, U.K. (19). Typically these alloys could contain about 10-15%Mn, 4-5%Al, 8-11%Cr, bal. Fe with yield stresses reaching about 600Mn/m^2 (90ksi) for 15%Mn alloys. They exhibit good oxidation and sulfidation resistance up to 1000°C and are superior to 18/8 stainless steels. Figure 12 shows their behavior in aggressive sulfide-bearing environments compared with the Cr-rich oxidation resistant materials(20). These alloys can be processed by production forming routes similar to 304SS although higher forces are necessary for equivalent deformations but no intermediate annealing is required. Some of the industrial applications of these steels could include naptha reforming

plants, gas and oil burners, automobile exhaust systems, desalination equipment etc.

Review of Some Preliminary Work Spurred by the 1977-78 Papers

The publication of these papers (1,2) by the author on Cr-and Ni-free stainless steels did attract quite a bit of attention. A large number of inquiries were received concerning various properties and utility of the Fe-Mn-Al alloys proposed in these papers. Since very little information was available in the literature at that time and since I was not and I am still not actively pursuing a research and development program on this subject, most of those inquiries remained unanswered. Now, 3-4 years later they are still largely unanswered. However, I was fortunate enough to be in a position to provide some samples of these alloys to those who were interested in doing some exploratory work of their own. Some of them have now reported the preliminary findings of their work. Others, who were more stimulated by the idea of the Fe-Mn-Al system made their own alloys for their investigations. Some of them have also reported their early results. Some of these preliminary results are quite encouraging and some are rather discouraging. Also, some of these efforts are quite thorough and some are rather tentative. Therefore, it should be remembered that some of the negative results may not necessarily be a true reflection of the alloy but may simply be due to a lack of committment, time, interest, funding, manpower etc. on the part of the investigator to undertake a comprehensive and more systematic study. All these preliminary results were reported to me privately and have not been published yet. Although it is a great pleasure for me to provide a brief summary of these early results, it is not my intent to "let the cat out of the bag" or deprive the original investigators of their recognition. It is only hoped that this brief

exposure of their work will be beneficial in providing added stimulus to them and others in further exploring the full potentials of these Fe-Mn-Al alloys. - - - A joint program (21) was initiated between Foote Mineral Co. and Sandia Laboratories to investigate the hot working characteristics of Fe-Mn-Al alloys with the eventual goal of using these materials for nuclear waste containment. The chemical composition of the alloys for this initial study are shown in Table 10. Ninety-five pound ingots were melted under argon atmosphere using a combination of high-carbon ferromanganese and electrolytic manganese and stock aluminum. The examinations for macro segregation in the ingots showed that the chemical compositions were remarkably homogeneous from one end of the ingot to the other as determined by qualitative emission spectroscopy. This was confirmed by quantitative chemical analysis. Microsegregation was examined by measuring the dendritic arm spacing as a function of distance from the as-cast wall. Attempts were also made to identify the chemistry of the various as-cast constituents using x-ray and microprobe analysis techniques. The dendritic arm spacing measurements were grouped between $1-2 \times 10^{-3}$ in. without any evidence for microsegregation. The results of these macro and microsegregation are in contrast to those of Charles et. al. (15).

Microprobe examination indicated that all of the alloys were 2-phase in the as-cast state. One of these phases, both appearing austenitic by x-ray analysis, tended to Mn rich, the other Fe rich. Probe analysis indicated the Al and C were uniformly distributed. Further, Si also was uniformly distributed, except for the S4 alloy, where there was some tendency for the Si to be associated with the Mn rich phase.

Homogenization: Homogenization temperatures were established by holding samples for 4h at temperatures between 900 and 1200°C followed by air cooling. Table 11 presents the final homogenization temperatures selected for further study.

S1, S2, S4, and S6 all responded in a similar fashion, that is above 1050-1100°C the alloy was single phase, all memory of the cast structure having been eliminated by the homogenization treatment. S5 was single phase at 1050°C, 2-phase ($\gamma + \delta$) at 1100°C and still retained the as-cast structure at 1000°C. Finally, numerous attempts to achieve a single phase austenite in S3 were unsuccessful. It was two-phase up to 1200°C. S3 was therefore dropped from the program.

Hot Ductility: The hot ductility of the as-cast and homogenized Fe-Mn-Al alloys was evaluated using a Gleeble test at an effective strain rate of 20 sec⁻¹.

Although this test procedure is rather crude, it does allow one to examine the influence of test temperature on the ductility and thereby select an ingot breakdown temperature. Figure 13a-e summarize the results. All of the alloys exhibit better hot ductility following homogenization. Apparently, the low ductilities of S1, S4, S5, and S6 in the as-cast condition at temperatures greater than 1100°C is associated with a tendency for the failure to follow the interface between the Mn and Fe rich phases. The behavior of S2 is anomalous in that regard and is not understood at this time.

Based on these results, the following ingot breakdown procedure is suggested.

1. All alloys to be homogenized per Table 11.
2. Ingot breakdown with starting temperatures (°C):

S1	900
S2	1025
S4	900
S5	950
S6	1025

These temperatures assume some adiabatic heating during deformation. The actual ingot breakdown according to the above schedule and extruding of bars will now be pursued.

- - - Contrary to all the evidence in the literature regarding the workability of Fe-Mn-Al alloys, a domestic steel company had considerable difficulty in

cold rolling an Fe-30Mn-8Al-1C alloy (22). They attempted to cold roll a $\frac{1}{2}$ " thick hot-rolled piece and surface ground for another purpose. No solution annealing or homogenization was performed prior to cold rolling attempts. In this condition it could not be cold rolled. So, it was hot rolled to 0.1" thickness from 2150°F but edge cracking was experienced. The edges were trimmed and then the cold rolling of the 0.1" thick material down to 0.05" could be performed successfully. It is believed that if the original material had been solution annealed and quenched prior to attempting the cold rolling operation it would have been successful. The fast cooling rate of the 0.1" thick material after the intermediate hot rolling may have simulated the solution anneal and quenching treatment, thus, making the subsequent cold rolling down to 0.05" possible. As mentioned earlier the properties of this type of alloys are very sensitive to heat treatment and state of prior mechanical working which must be kept in mind during processing of these materials.

- - - The Defence Metallurgical Research Laboratory in India has undertaken some work on the austenitic 32Mn-9.6Al-1C-Fe alloys to characterize its mechanical properties, deep drawability, oxidation and corrosion resistance (23). Structural characterization is also being carried out to understand the mechanism and kinetics of aging. The room temperature mechanical properties of hot worked solution annealed and aged specimens showed the typical age-hardening peak at about 600°C aging temperature in agreement with previous observations of other workers (5-10). This peak strength corresponds with a minimum in ductility which is still quite high. The Erichsen cup test for deep drawability showed identical cup depths for the Fe-Mn-Al alloys and 304 stainless steel for 1.45mm thick sheets. In 0.63mm thick sheets these alloys showed higher cup depths than 304 although the load requirement for the Mn-Al steel in both cases was about 30% higher.

100 hour oxidation test data showed these steels to be marginally inferior at 700°C, and substantially inferior at 900°C to 304SS. Corrosion rates of half immersed samples of these alloys in 7.5% NaCl were approximately double compared to 304SS. In 50% HCl the results were considerably poorer than 304. However, no attempts to etch away the two-phase surface layer or any other surface preparations were made yet as suggested by Batrakov et. al. (11). The corrosion results after such surface treatment will be of interest. Compositional modifications are also being planned to improve the corrosion and high temperature oxidation resistance.

The cast, homogenized, and aged samples showed the presence of the austenite phase only. The cold-rolled samples and samples cooled to liquid nitrogen temperatures also showed the austenite phase only. In the as-cast condition the alloy was magnetic but in the homogenized and solution treated condition it was non-magnetic. Aging between 500-800°C caused the alloy to be magnetic again. Currently, work is in progress to study the kinetics of aging at various temperatures. Thorough investigation of the microstructural details and correlation with the properties is also underway.

- - - A "Femnal 30" alloy containing Fe-30Mn-8Al-0.8C also showed its oxidation resistance being limited above about 600°C (24). This alloy was also found to be unable to resist oxidation/sulfidation attack by multi-component gas mixtures (H₂S/H₂O/H₂) at 1800°F. The alloy disintegrated after about 100 hours of testing. However, resistance at lower temperature has not been investigated. The preliminary results of an ongoing work on resistance to sulfidation in a reducing atmosphere of H₂+1 vol.% H₂S show this alloy to be the most resistant material presently available, being 10 times more resistant than the 300 series stainless steels. This is believed to be due to the formation of a "peg-like" duplex scale, consisting of an outer layer of MnS with an inner layer of Al₂S₃,

which is highly resistant to spallation.

Thile it is too early to speculate, such alloys do seem very promising as sulfidation resistant materials in reducing atmospheres. At present this Femnal 30 alloy is being tested in a pilot plant oil gasifier in the U. K.

- - - Some early results of corrosion tests in the as-rolled condition of an "Anodinox T-04" alloy (Fe-36.5 Mn-7.4 Al-0.13C) were very poor in 10% H_2SO_4 , 1%HCl, 65% HNO_3 , and 20% CH_3COOH (25). A polarization curve in 10% H_2SO_4 showed no passivation region for this alloy for a current density up to 1 A/ cm^2 . Again, it must be remembered that the alloy was tested in the as-rolled condition with no removal of the Al-impoverished two-phase surface layer. It is hoped that the fully austenitic homogenized alloy after the removal of the scale and the two-phase surface layer will give improved results. Some modification of the composition are also planned.

- - - A small foundry in Italy produced some cast test bars of an alloy consisting of Fe, 35.4%Mn, 9.75%Al, 1.7%Si, 0.79%C. The corrosion resistance of these test bars in chlorinated media were found to be very poor compared to 316SS. However, no further details of the test, the surface condition of the test bars and their heat treatment are known (26).

- - - The preliminary results from a large oil company in the U.S.A. indicate that these Fe-Mn-Al alloys have very good corrosion resistance in carbonic acid media (27). The alloys tested were essentially Fe-30Mn-8Al-1C with or without 1.5%Si. These alloys were about 15-20 times more corrosion resistant in this medium compared to C-steels and were nearly equivalent to 9Cr- or 9Cr- Mo steels. The silicon-containing alloy was even more corrosion resistant. Therefore, these alloys may have some promise in routined non-severe "sweet environments" of oil field applications.

- - - A company in the business of composite materials performed some preliminary

tests with these alloys to explore the feasibility of using these steels for high temperature composite material matrices which could replace some Cr-containing high temperature superalloys (28). The composition of the alloys tested were Fe, 30%Mn, 8-10%Al, 0.5-1.25%C, 0-1.5%Si. First, they were able to produce 10-12 mils thick sheets of these alloys. These were subjected to standard vacuum diffusion bonding process. The initial small scale test of bonding tungsten fibers to these alloys was successful. The next planned step was the bonding of SiC filament reinforcement. The results of that are not known.

Summary

It is quite clear that there are some conflicting observations and experiences about the behavior of these Fe-Mn-Al alloys. The mechanical properties and aging characteristics are known and consistent to a certain extent. Some scattered and preliminary information on some of the other properties have emerged over the last 3-4 years although the lack of systematic and concerted efforts in many cases make some of this information rather tentative. In addition, the data-base on many other important engineering properties such as machinability, weldability, creep, fatigue etc. are totally non-existent. However, the available knowledge on these alloys, albeit meager, do point to the future potentials of these materials at least in some specific applications. It is clear that thorough and systematic studies of this new class of materials are required. They represent one possibility of chromium-free substitutes, perhaps in some selected non-critical applications. If the chromium situation is serious enough, which I believe it is, we cannot afford to ignore or discount it without serious and concerted efforts to evaluate its potentials.

Acknowledgements

The author is grateful to A. Gray of the American Society of Metals for

continued encouragement and Foote Mineral Company for continued support of the ideas presented here.

References

- 1) S. K. Banerji; "An Austenitic Stainless Steel Without Nickel and Chromium", Metal Progress, p. 59, April (1978).
- 2) S. K. Banerji; "An Austenitic Stainless Steel Without Nickel and Chromium", Trans. Indian Inst. Met., Vol. 30, N. 3, p. 186, June (1977).
- 3) "Contingency Plans for Chromium Utilization", Publication #NMAB-335, National Academy of Sciences, Washington, D.C. 20418, (1978).
- 4) G. A. Watson; "Chromium-Today and Tomorrow", Iron and Steel Maker, p. 19, May (1980).
- 5) G. L. Kayak; "Fe-Mn-Al Precipitation-Hardening Austenitic Alloys", Metal Science and Heat Treatment, 2, p. 95, (1969) - in English, translated from Metallov. i Term. Obra. Metallov., No. 2, p. 13, Feb. (1969).
- 6) M. F. Alekseenko, G. S. Krivonogov, L. G. Kozyreva, I. M. Kachanova, and L. V. Arapova; Metal Science and Heat Treatment, 14, (3-4), p. 187, (1972) - in English, translated from Metallov. i Term. Obra. Metallov., No. 3, p. 2, March (1972).
- 7) P. J. James; "Precipitation of the Carbide $(FeMn)_3AlC$ in an Fe-Al Alloy", J. Iron & Steel Inst., p. 54, Jan. (1969).
- 8) G. S. Krivonogov, M. F. Alekseyenko, and G. G. Solov'yeva; "Phase Transformation Kinetics in Steel 9G28Yu9MVB", Phys. Met. & Metallog., (4), p. 86, (1975) - in English-translated from Fiz. Metal. Metalloved., 39, No. 4, p. 775, (1975).
- 9) L. I. Lysak, M. F. Alekseyenko, A. G. Drachinskaya, N. A. Storchak, and G. S. Krivonogov; "Structural and Phase Changes in Steel 9G28Yu9MVB During Aging", Metallogizika, 59, No. 4, p. 29, (1975) - in Russian.
- 10) N. A. Storchak and A. G. Drachinskaya; "Nature of Age Toughening of Fe-Mn-Al-C Alloys", Fizika Metallov. i Metalloved., 44, (2), p. 373, (1977) - in Russian, avail. in English as "Strengthening of Fe-Mn-Al-C Alloys During Aging", Phys. of Met. & Metallog., 44, No. 2, p. 123, (1978).
- 11) V. P. Batrakov, M. F. Alekseenko, L. A. Filimonova, G. S. Krivonogov, L. G. Kozyreva, V. G. Sapozhnikova, and V. A. Molotova; "State of the Surface Layer and Corrosion Resistance of Steel 9G28Yu9MVB", Prot. Met., 10, (5), p. 487, (1974) - in English - translated from Zashchita Metallov., 10, (5), p. 533, Sept.-Oct. (1974).
- 12) R. E. Cairns, Jr. and J. L. Ham; "Aluminum-Manganese-Iron Alloys", U.S. Patent No. 3,111,405, Nov. 19 (1963).
- 13) J. L. Ham and R. E. Cairns, Jr.; "Manganese Joins Aluminum to Give Strong Stainless", Product Engineering, 29, (52), p. 50, 22 Dec. (1958).

- 14) W. H. Richardson; "Iron-Aluminum Alloys", U.S. Patent No. 3,193,384, July 6 (1965).
- 15) J. Charles, A. Berghezan, A. Lutts, and P. L. Dancoisne; "New Cryogenic Materials: Fe-Mn-Al Alloys", Metal Progress, p. 71, May (1981).
- 16) "Manganese-Aluminum Steel"; Materials Handbook, G. S. Brady, 10th Edition, p. 497, McGraw-Hill.
- 17) P. Weintraub; "U.S. Seeking New Kinds of Stainless Steels", American Metal Market/Metal Working News, p. 8, 24 Dec. (1979).
- 18) B. H. LeCerf; "Chromium Substitutes Worth A Second Look", Iron Age, p. 42, 29 May (1978).
- 19) "New Family of Manganese Stainless Steels" - in Mn News, published by Manganese Centre, 17 Avenue Hoche, 75008 Paris, France
- 20) P. L. Dancoisne; "Research and Development of Manganese", Materiaux & Techniques, Special Issue - Manganese, p. 127, Dec (1977), Paris, France.
- 21) H. J. Rack and S. K. Banerji, unpublished work, (1980).
- 22) J. C. Jasper, private communication, (1979).
- 23) M. L. Bhatia, R. Sivakumar, and Narasimha Rao, private communication, (1981).
- 24) P. Tomas, private communication, (1981).
- 25) F. J. M. Boratto, private communication, (1980).
- 26) R. Boscarelli, private communication, (1980).
- 27) M. T. Orillion, private communication, (1981).
- 28) J. F. Dolowy, Jr., private communication, (1979).

Table 1 World Chromium Ore Resources - ref.(3)

Country	Known Ore Reserves		Known Potential Ore	
	Million Short Tons Ore	% World	Million Short Tons Ore	% World
South Africa	1,194	62.4	2,333	76.5
Rhodesia	626	32.7	626	20.5
USSR	24	1.2	25	0.8
Philippines	5	0.3	< 1	< 0.05
Turkey	2	0.1	6	0.2
All other	<u>63</u>	<u>3.3</u>	<u>58</u>	<u>2.0</u>
Total	1,914	100.0	3,049	100.0

TABLE 2 U.S. Chromium Imports from Various Sources, 1963-1976 (1,000 short tons)

Year	USSR	Turkey	South Africa	Rhodesia	Philippines	Other	Total
1963	64	25	186	89	47	23	434
1964	103	32	134	110	51	29	459
1965	91	51	163	110	61	29	505
1966	112	59	280	65	77	48	641
1967	113	35	164	49	43	23	427
1968	125	49	147	--	38	23	382
1969	118	56	141	--	44	24	383
1970	170	79	137	--	48	35	469
1971	112	107	141	8	36	27	431
1972	154	40	109	40	29	59	431
1973	82	41	126	51	44	44	388
1974	103	40	142	47	58	42	432
1975	120	53	147	101	48	111	580
1976	61	61	172	67	37	101	499

NOTE: Based on data from U.S. Bureau of Mines 1963-1975 and 1976.

* 1979 Total import 450,000 tons

* 2000 proj. import 840,000 tons

} I&SM, May 1980 - ref.(4)

TABLE 3 Prospects for Chromium Savings by Materials Substitution and Redesign (1,000 short tons) - ref.(3)

End Use	Consumption Forecast for 1977	Potential Chromium Savings	
		Category 1 ^a	Category 2 ^b
<u>Metallurgical</u>			
Wrought stainless and heat-resisting steels	232	69.6 (30%) ^c	69.6 (30%)
Tool steels	6	0 (0%)	0 (0%)
Wrought alloy steels	43	6.5 (15%)	30 (70%)
Cast alloy steels	14	1.4 (10%)	8.4 (60%)
Alloy cast irons	8	0.8 (10%)	4.8 (60%)
Nonferrous alloys	14	0 (0%)	0.7 (5%)
Other	6	1.8 (10%)	1.8 (50%)
Subtotal	323	80.1 (24.8%)	115.3 (35.7%)
<u>Refractories</u>			
Chrome and chrome-magnesite brick	10	7.5 (75%)	2.5 (25%)
Magnesite-chrome brick	14	4.0 (28%)	8.0 (56%)
Granular chrome-bearing materials	27	5.0 (18.5%)	20.0 (74%)
Granular chromite	10	4.0 (40%)	4.0 (40%)
Subtotal	61	20.5 (33.6%)	34.5 (56.6%)
<u>Chemicals</u>			
Pigments	18	4.5 (25%)	9.0 (50%)
Metal finishing	15	7.5 (50%)	2.3 (15%)
Leather tanning	11	0 (0%)	11.0 (100%)
Drilling muds	3	0 (0%)	0 (0%)
Wood treatment	4	2.0 (50%)	2.0 (50%)
Water treatment	4	0 (0%)	2.0 (50%)
Chemical manufacture	5	0 (0%)	2.5 (50%)
Textiles	2	1.0 (50%)	1.0 (50%)
Catalysts	< 1	0 (0%)	0 (0%)
Other	5	1.0 (20%)	3.0 (60%)
Subtotal	68	16.0 (23.5%)	32.8 (48.2%)
Total	452	116.6 (25.8%) ^d	182.6 (40.3%) ^d

^a Technically feasible now.

^b Potentially feasible after 10 years of research and development.

^c Number in parentheses indicates percent saving of consumption forecast for each end use category.

^d Percent saving of total for all categories.

TABLE 4 Example of Possible Chromium Savings in Stainless Steel (tons) - ref. (3)

SIC Number	SIC Code	U.S. Chromium Demand in 1972	Possible Chromium Savings	Chromium Use After Savings
25	Furniture and fixtures	2,400	2,280 (95%) ^a	120
33	Primary metal industries	13,000	11,700 (90%)	1,300
34	Fabricated metal products	61,000	30,500 (50%)	30,500
35	Machinery, except electrical	40,000	20,000 (50%)	20,000
36	Electrical machinery, equipment and supply	10,000	4,000 (40%)	6,000
37	Transportation equipment	19,500	18,100 (93%)	1,400
38	Instruments and related products	2,800	560 (20%)	2,240
39	Misc. manufacturing industry	8,000	7,600 (95%)	400
19	Ordnance and accessories	1,250	0 (0%)	1,250
11, 12, 13, 14	Mining, petroleum, natural gas	170	0 (0%)	170
15, 16, 17	Building construction, contractors	9,400	4,700 (50%)	4,700
13	Crude petroleum, natural gas	330	0 (0%)	330
	Total	167,850	99,440	68,530

NOTE: Data from U.S. Department of Commerce, Standard Industrial Classifications, 1972.

^a The figures in parentheses indicate the percentage of possible chromium savings in that category.

TABLE 5. Permeability of Fe-Mn-Al Alloys after Quenching and after Quenching + Aging 20 h at 600°C - ref. (5)

Composition, %			Permeability, G/Oc	
C	Mn	Al	quenched	quenched + aged 20 h at 600°C
0.93	23.7	8.2	1,008	1,900
0.96	28.2	8.3	1,009	1,046
0.95	30.1	7.9	1,007	1,040
0.97	30.5	10.6	1,038	3,860
0.96	34.1	10.1	1,017	2,450

Table 6: Composition and Mechanical Properties of some Fe-Mn-Al Alloys - ref.(12)

Alloy No.	Percent Al	Percent C	Percent Mn	Percent Other	Percent Austenite	Test Temp. ¹	Heat Treat. ²	Tensile Sgth.	Yield Sgth.	Percent E	Percent R. A.
133	16.4	0.02		Mo-2.5	0	RT		110,000		10	
						1,200		50,000	20,000	55	90
131	14.5	0.04		Ti-2.9	0	RT	2,000Q	34,000	33,000	0	0
						1,200	1,450Q	47,250	45,000	14	46
						RT	2,000Q	92,500	79,500	2	5
136	9.4	0.05	20.6		10	RT	1,450Q	107,750	78,000	30	60
						1,200	2,000Q	33,750	33,750	0	0
						1,200	1,450Q	17,000	16,500	187	99
172	15.3	1.08	28.3		20	RT	2,000Q	168,000	132,000	4.5	2.4
						1,200	2,000Q	74,250	12,000	166	98
						RT	2,000Q	141,000		14	14
173	12.2	0.67	25.2		40	RT	2,000FC	111,000	96,000	2.5	3
						1,200	1,450Q	130,500	69,450	3.5	4
						1,200	2,000Q	55,750	45,000	22	24
179	7.0	0.03	39.3		100	RT	2,000Q	71,750	28,800	55	72
						1,200	2,000FC	72,000	22,500	57	72
						1,200	2,000Q	41,250	18,000	88	66
196	16.5	0.55	10.4	Mo-2.8	0	RT	1,450Q	75,000	69,000	0	0
						1,200	2,000FC	84,900	45,000	0.5	0.3
						1,200	1,450Q	62,500	12,000	62	65
210	14.6	0.02		MM-0.22	0	RT	2,000Q	116,250	102,750	1.0	2.0
						1,200	2,000FC	110,000		1.5	1.0
						1,200	2,000Q	29,500	21,000	92	87
213	10.2	0.76	34.4		100	RT	2,000Q	109,000	55,000	73	71
						1,200	2,000FC	110,750	81,000	72	82
						1,200	2,000Q	60,500	40,500	34	32
214	7.5	0.79	37.0		100	RT	2,000Q	115,000	51,000	62	73
						1,200	2,000FC	115,750	54,750	66	71
						1,200	2,000Q	63,750	33,000	65	64
226	10.0	0.27	33.8	Ni-2.3	60	RT	2,000Q	119,000	65,500	45	51
						1,200	2,000FC	97,750	49,600	25	30
						1,200	2,000Q	38,600	27,600	51	41
227	12.5	0.30	33.0	Ni-4.3	70	RT	2,000Q	118,500	63,750	45	52
						1,200	2,000FC	110,500	55,300	35	32
						1,200	2,000Q	40,600	30,000	37	31
228	9.3	0.34	35.4	Ni-6.4	80	RT	2,000Q	123,000	63,250	43	39
						1,200	2,000FC	114,000	52,500	35	32
						1,200	2,000Q	49,000	36,000	31	31

¹ RT=Room Temperature; 1200=1200° F.
² The number is the temperature in degrees F. that the alloy was held at prior to cooling. The suffix describes the manner in which the alloy was cooled: Q=hot oil quench; FC=furnace cool.
³ Sheet Specimen NAVORD Report 4237 "Applications, Properties and Fabrication of Thermanol Type Alloys."

Table 7. Oxidation Test Results on Mn-Al Steels of Table 6 - ref.(12)

(Depth of oxide penetration in inches)

Alloy No.	1,500°F. - 100 hours	2,200°F. - 46.5 hours
133.....	.0005	.0005
134.....	.0005	.0005
136.....	.0005	.0015
172.....	.0005	.0005
173.....	.0005	.002
196.....	.0005	.001
210.....	.0005	.0005
213.....	.0065	.014
214.....	.0155	.047
226.....	.001	.0075
227.....	.002	.0035
228.....	.004	.005
310 stainless steel.....	.0005	.0025
S-816 (cobalt base).....	.0005	.0625
U-500 (nickel base).....	.0005	.0025

Table 8. Composition of Mn-Al Steels used in ref. (14)

Example	Al	Mn	C	Cb	Ni	Other
1.....	9.45	21.1	1.04	0.30
2.....	10.1	23.5	1.0	0.92
3.....	10.61	24.5	1.1	0.63
4.....	10.95	23.5	1.12	0.77
5.....	9.32	21.6	0.93	0.54
6.....	9.12	25.0	0.98	0.19
7.....	9.95	25.0	1.04	0.70
8.....	9.94	24.7	1.01	3.37 W.
9.....	6.93	21.0	0.86	6.64 W.
10.....	9.69	24.5	1.12	0.20	0.52 W.
11.....	9.23	28.7	1.0	5.4 W.
12.....	9.32	22.0	0.92	11.9 W.
13.....	10.52	25.5	1.16	4.60 W.
14.....	10.39	26.7	0.76	0.60 Mo.
15.....	9.80	24.9	0.94	0.81	3.25 Mo.
16.....	8.00	24.7	1.0	Nil	9.85
17.....	8.4	27.8	1.0	14.98
18.....	8.53	27.2	1.08	0.56	5.63
19.....	8.21	27.1	0.44	Nil	11.0	4.9 Cr. 10.48 Ti.
20.....	10.10	24.4	0.53	Nil	3.5 Cr.
21.....	8.00	24.8	0.99	0.63	10.13 Cr.
22.....	7.75	24.2	0.64	15.9 Cr.
23.....	10.10	23.1	1.04	0.64	2.10 Co.
24.....	9.14	24.4	0.96	Nil	1.55 Co.
25.....	9.01	25.8	0.86	2.1 Co.
26.....	9.49	23.6	0.98	0.70	0.26 Va.
27.....	9.64	27.4	0.92	Nil	0.71 B.
28.....	8.00	24.4	0.82	Nil	0.92 Ti.
29.....	9.92	24.7	0.86	0.60	0.64 Cu.
30.....	9.34	24.0	0.95	0.74	2.24 Cu.
31.....	10.37	24.4	0.82	Nil	2.0 Zr.
32.....	10.78	24.8	1.18	1.2
33.....	10.37	24.8	1.20	Nil	0.4 Co.
34.....	9.45	25.1	0.93	0.70

Table 9. (ref. (18))

Composition of Modified 304 Stainless Steel Alloys.								
Ferritic—1st Generation, Austenitic—2nd Generation								
Alloy	Nominal Chemical Composition, wt. %							
	Cr	Ni	Mn	Si	Al	Mo	C	Fe
304 Stainless Steel	18	8	1.1	0.65	—	—	0.06	Bal.
12% Cr-Si (Ferritic)	12	8	1.1	2.65	—	—	0.06	Bal.
12% Cr-Al-Mo (Ferritic)	12	8	1.1	0.65	2	2	0.06	Bal.
12% Cr-Si (Austenitic)	12	10	1.1	3.65	—	—	0.06	Bal.
12% Cr-Al-Mo (Austenitic)	12	10	5.1	1.65	2	2	0.06	Bal.

Table 10. Chemical Composition of Foote-Sandia Alloys -ref. (21)

<u>Alloy</u>	<u>% C</u>	<u>% Mn</u>	<u>% Al</u>	<u>% Si</u>
S-1	0.93	29.6	7.98	0.09
S-2	0.57	29.6	8.03	0.05
S-3	0.17	29.7	7.77	0.01
S-4	0.99	29.7	7.71	1.49
S-5	0.59	29.2	7.59	1.52
S-6	1.00	29.6	7.87	0.73

Table 11. Homogenization Temperatures for Fe-Mn-Al Ingots* of Table 10.

<u>Alloy</u>	<u>Temperature (°C)</u>
S1	1050
S2	1050
S3	----
S4	1050
S5	1050
S6	1100

*Homogenization time: 4h - air cool.

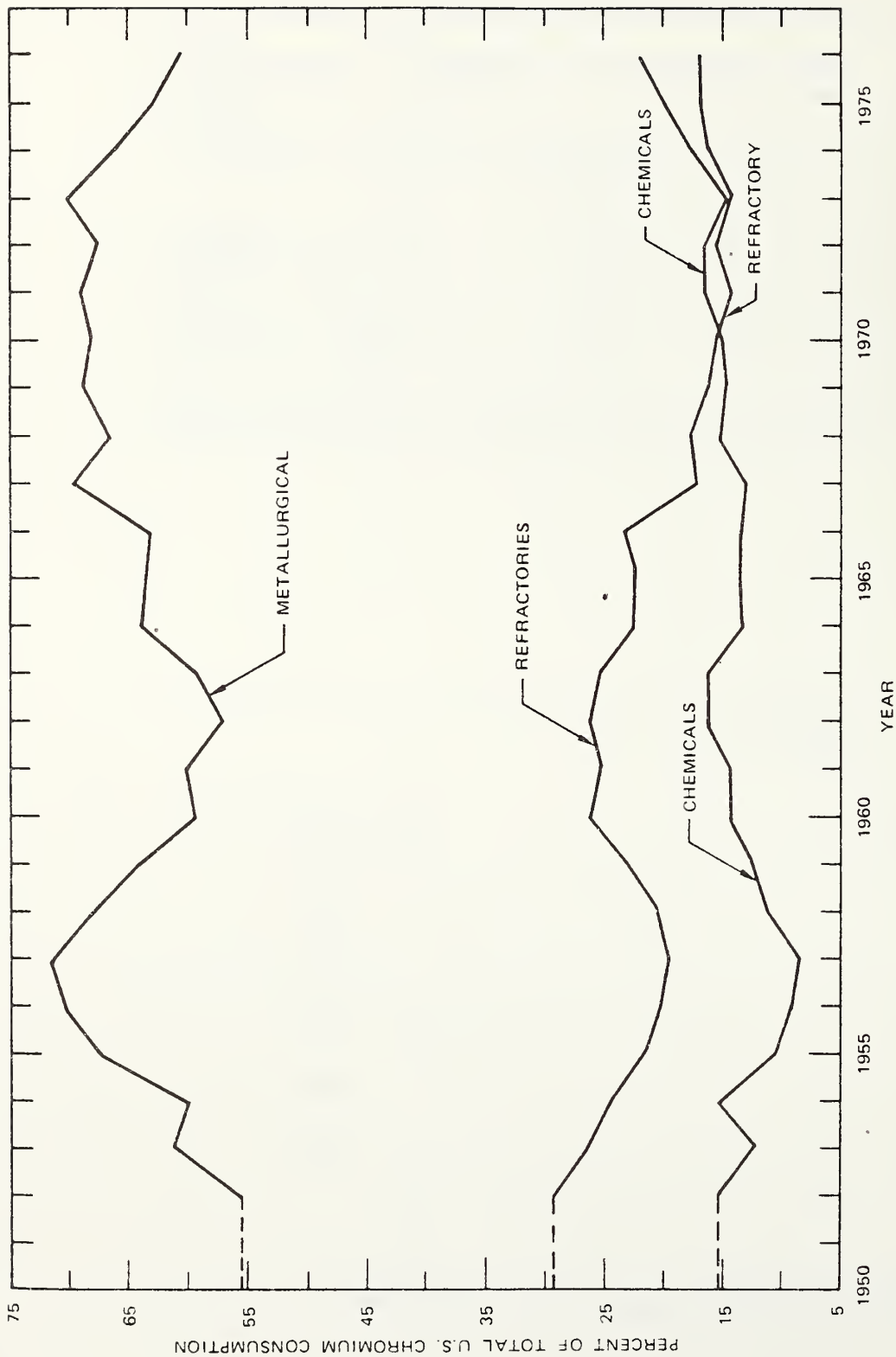

FIGURE 1 Historical Trends in the Relative Importance of Chromium Usage in Metallurgical, Chemical, and Refractory Applications (based on data from the U.S. Bureau of Mines 1950-1974, 1975, 1976) - ref.(3)

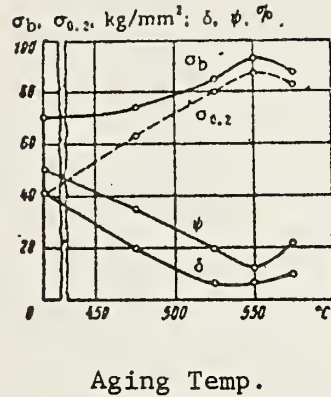

Fig. 2. Mechanical properties of an alloy with 27.5% Mn, 9.1% Al, and 0.92% C as a function of aging temperature (16 h). - ref. (5)

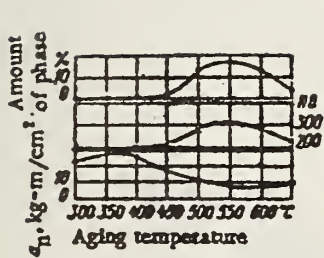

Fig. 3a

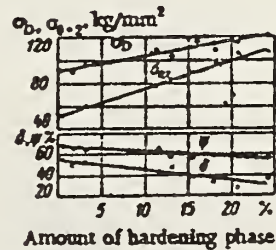

Fig. 3b

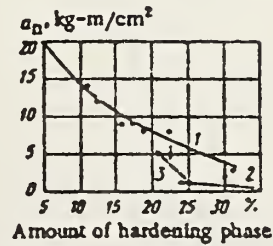

Fig. 3c

Fig. 3a) Variation of mechanical properties and amount of hardening phase with aging temperature (8 h) for steel 9G28Yu9MVB.

Fig. 3b) Variation of mechanical properties with amount of hardening phase for steel 9G28Yu9MVB.

Fig. 3c) Variation of toughness with amount of hardening phase in steel 9G28Yu9MVB:

1) grain size grade 4, 0.85% C; 2) grade 4, 0.95% C; 3) grade 1, 0.85% C.

- ref. (6)

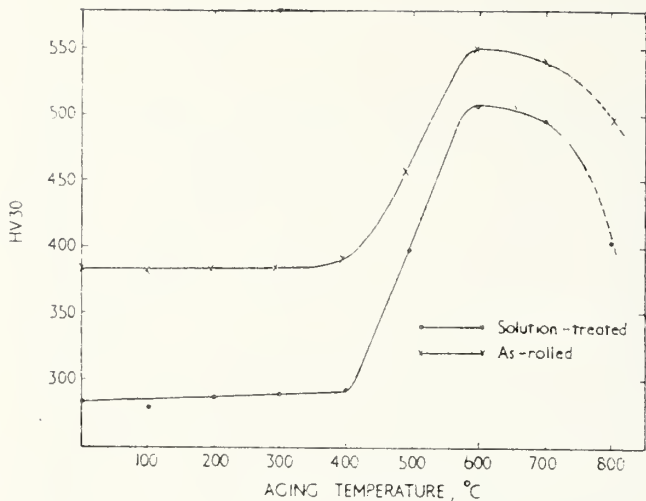

(a)

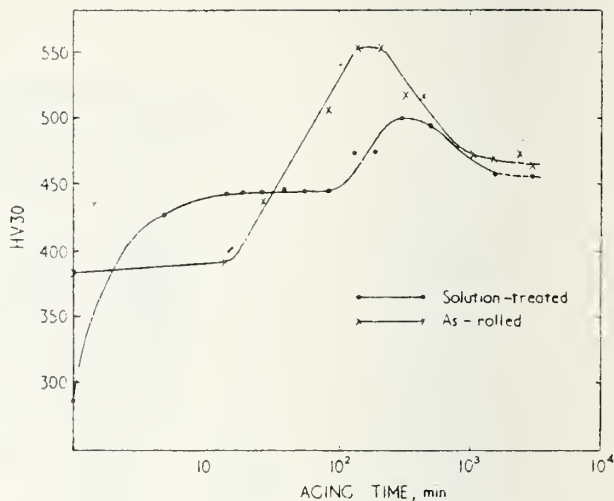

(b)

Fig. 4 Hardness versus a) aging temperature (4 hrs.) and b) aging time (at 600°C) for solution treated (1100°C, WQ) and as-rolled Fe-9Al-9.5Mn-.96C-6.77Ni alloy - ref. (7).

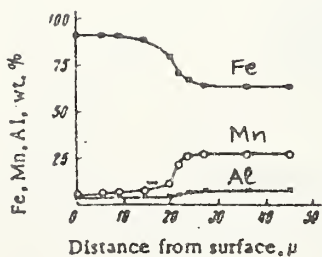

Fig. 5. Fe, Mn, and Al contents vs depth of surface layer of a cold-worked specimen of steel 9G28Yu9MVB after heating in a furnace atmosphere at 1100°C for 60 min. - ref. (11)

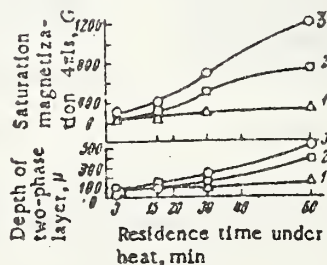
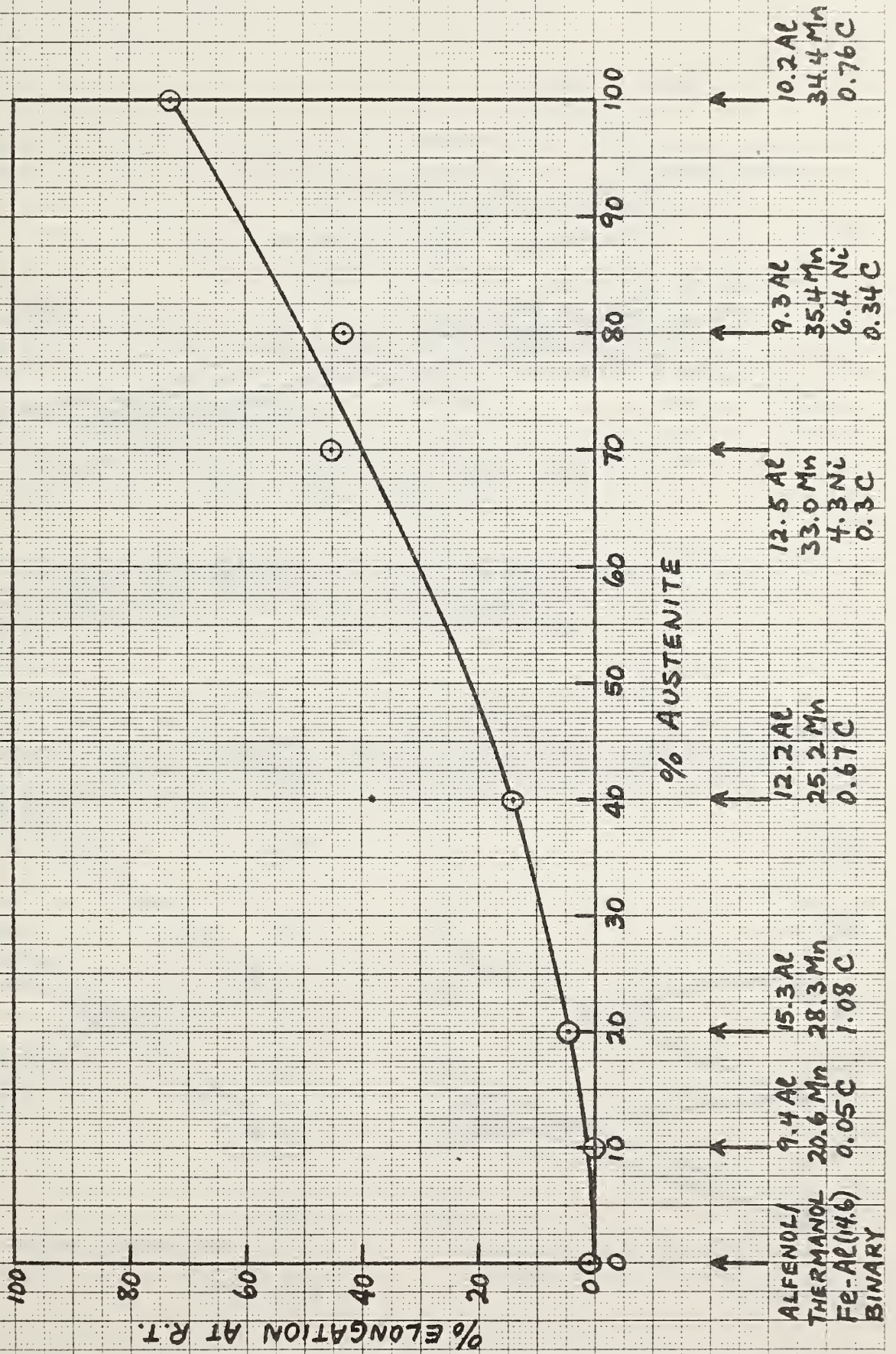

Fig. 6. Kinetics of growth of two-phase surface layer of steel 9G28Yu9MVB at (°C): 1) 1050; 2) 1100; 3) 1150. - ref. (11)

Fig. 7 Room temperature ductility of Fe-Mn-Al alloys as a function of austenite content of the alloy - ref. (12)



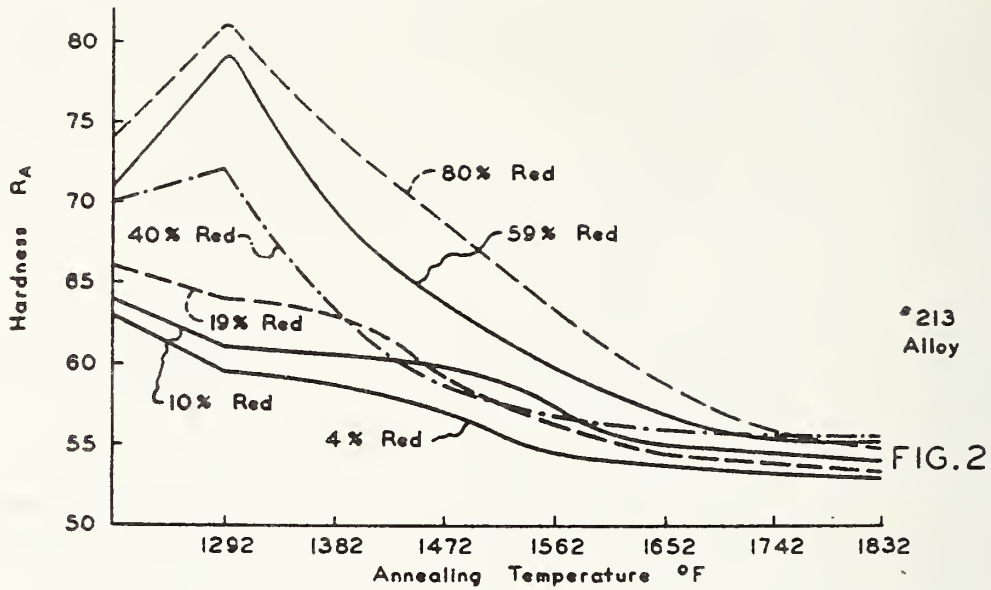

Fig. 8. Strain-Age-Hardening characteristics of cold-rolled Fe-10.2Al-34.4Mn-0.76C alloy (#213) after different amounts of cold reduction - ref.(12)

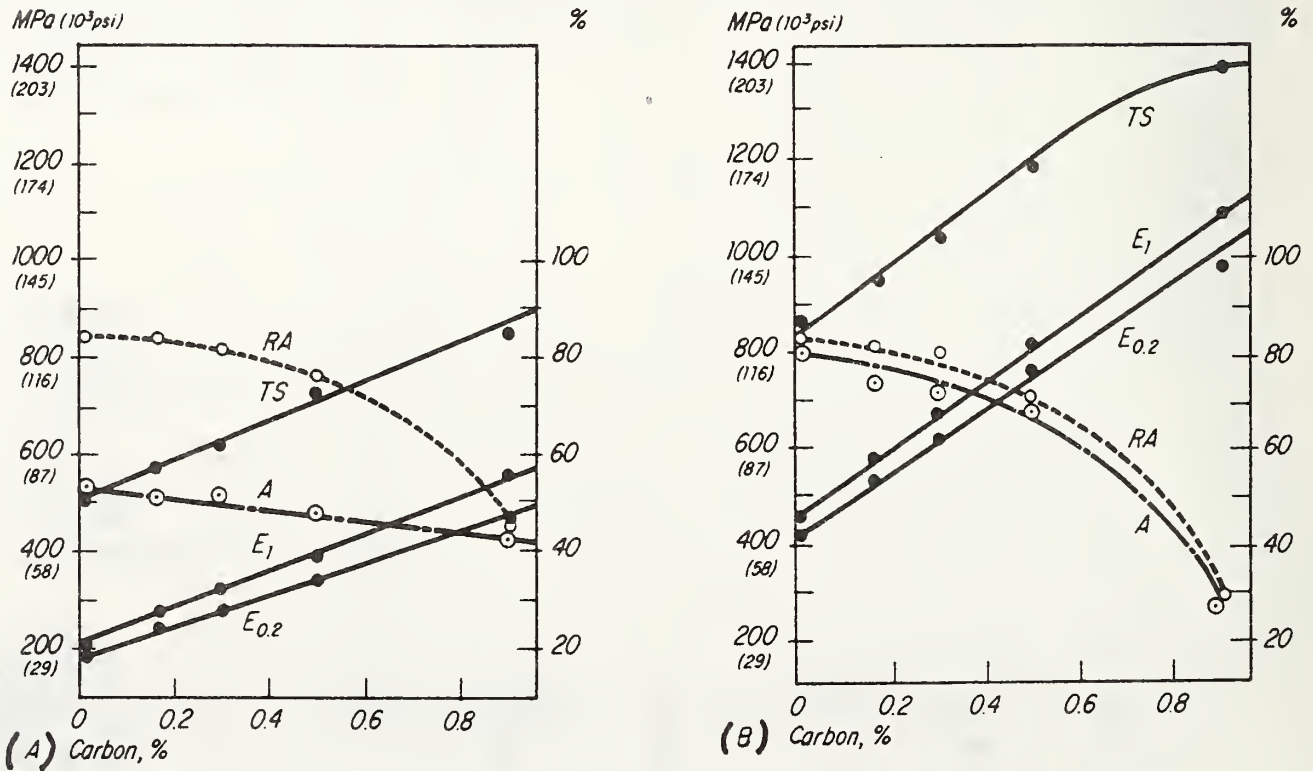

Fig. 9. The effect of carbon on the mechanical properties of Fe-30Mn-5Al alloys. Note that the properties at room temperature(A) are lower than those at liquid nitrogen temperature(B). TS=tensile strength; E_1 and $E_{0.2}$ =yield strength (1 and 0.2% offsets); RA=reduction in area; A=elongation. -ref.(15)

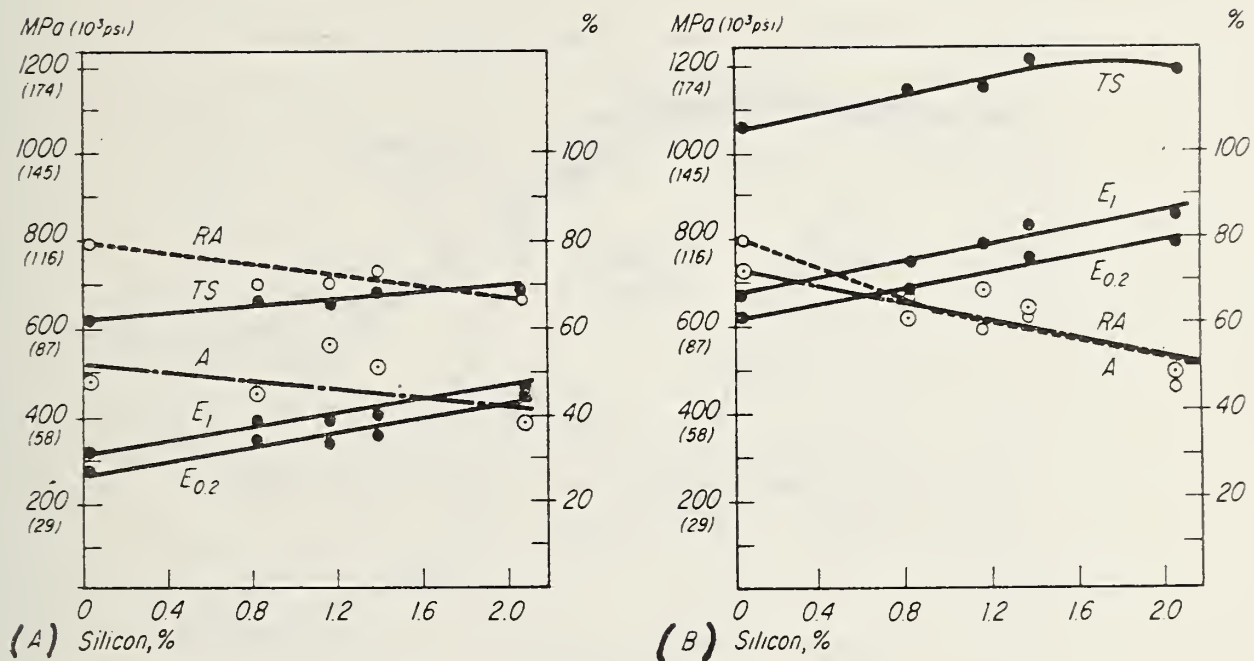

Fig. 10. The hardening effect of silicon in Mn-Al steels is shown at room temperature(A) and liquid nitrogen temperature(B). Again, better results are obtained at cryogenic temperatures. TS=tensile strength; E₁ and E_{0.2}=yield strength(1 and 0.2 offsets); RA=reduction in area; A=elongation. -ref.(15)

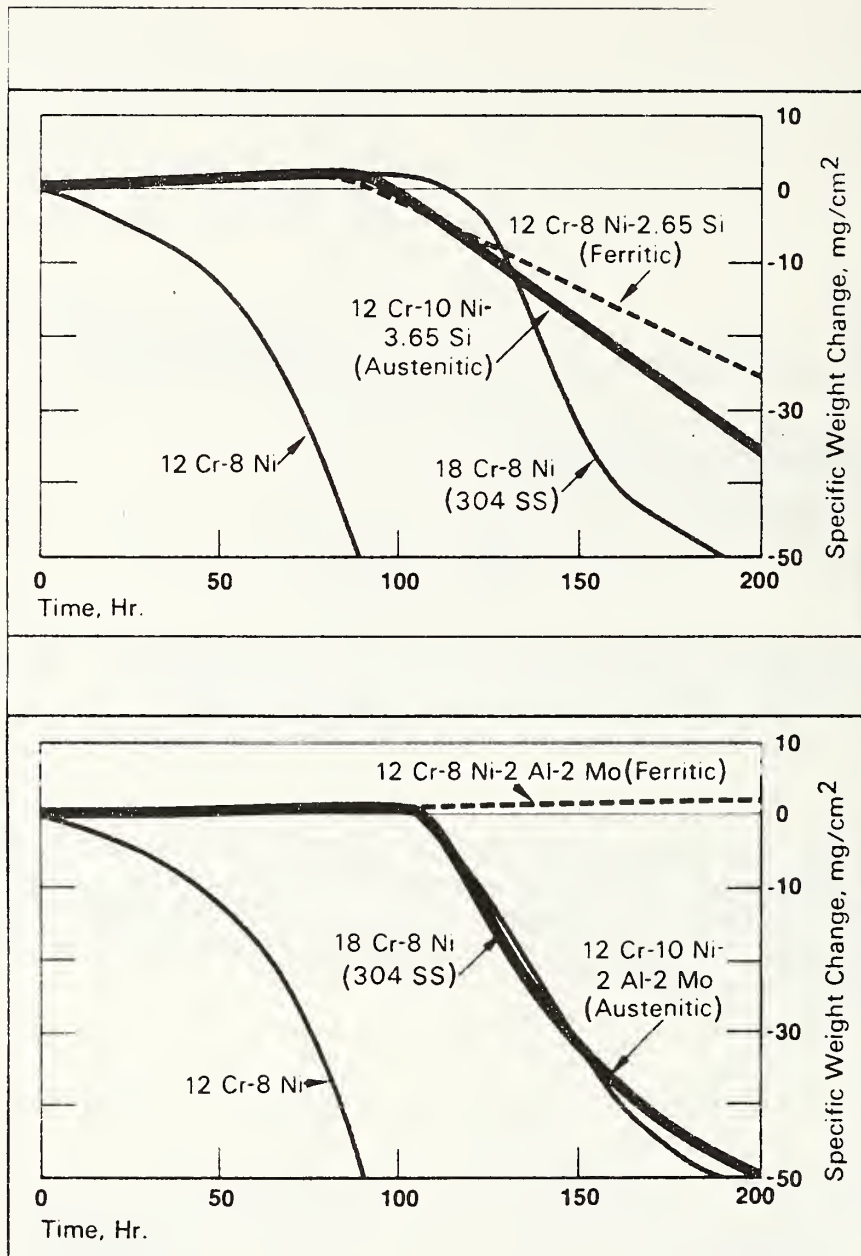

Fig. 11. Specific weight change data for modified 304 SS alloys. Cyclic oxidation temperature, 870°C. -ref. (18)

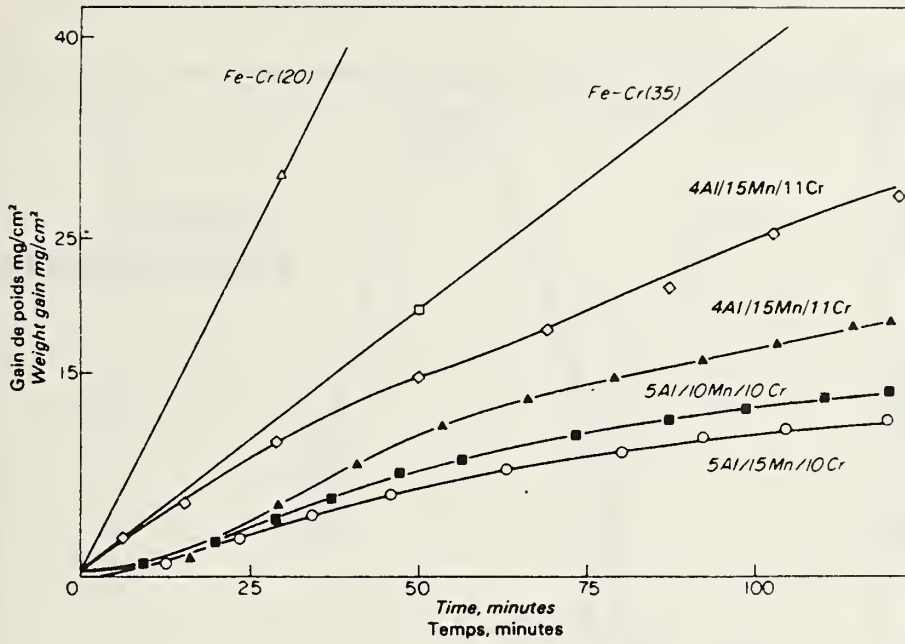

Fig. 12. Beneficial effect of aluminium and manganese on the sulphidation behaviour of stainless steels at 900°C. -ref. (20)

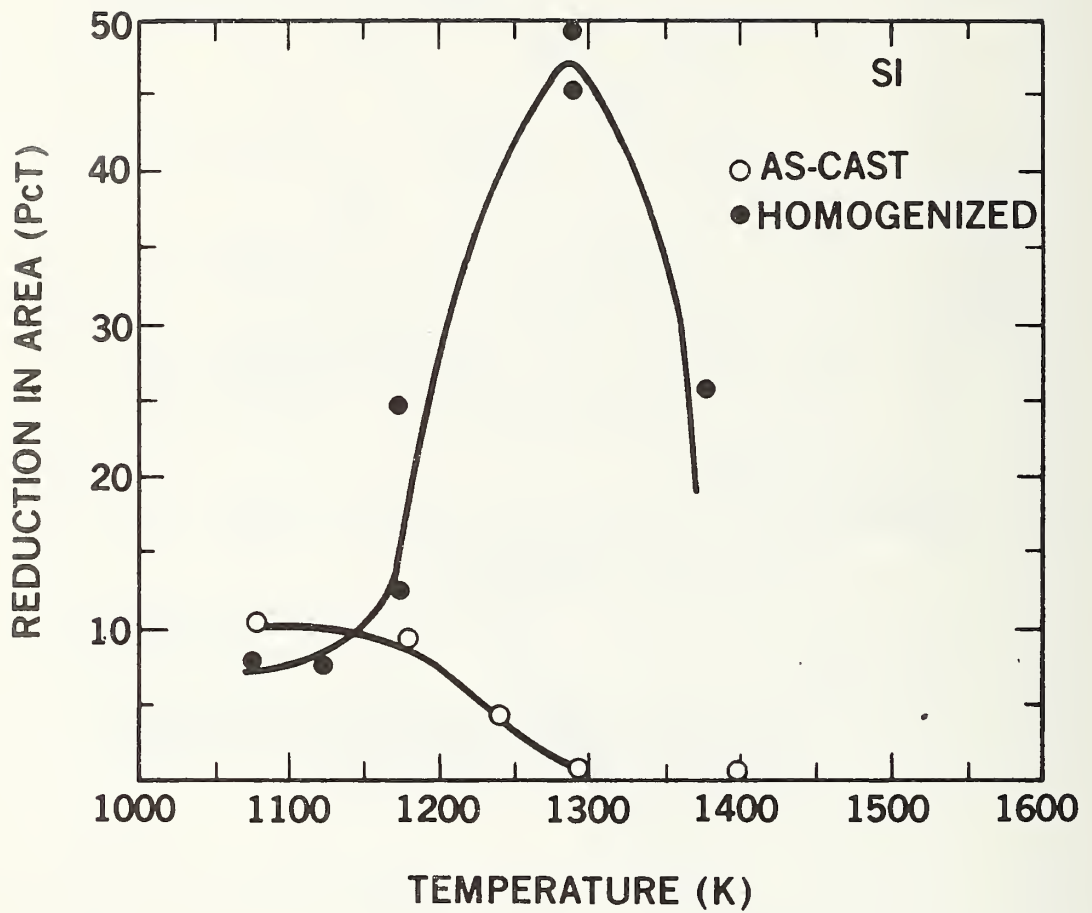

FIG. 13(A). HOT DUCTILITY TEST RESULTS FOR ALLOY S-1 - REF. (21)

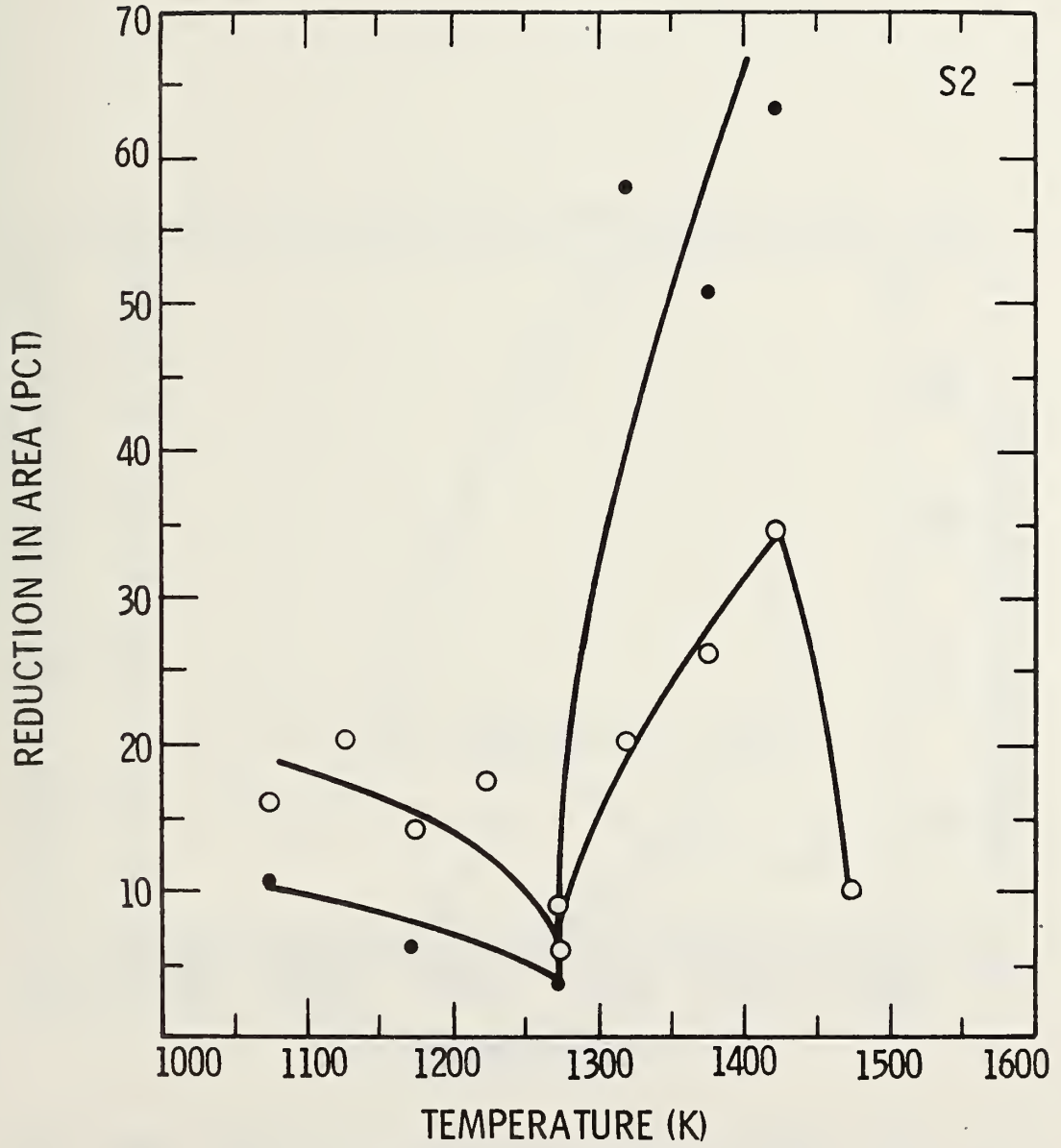

FIG. 13(B). SAME AS (A) FOR ALLOY S-2 - REF. (21)

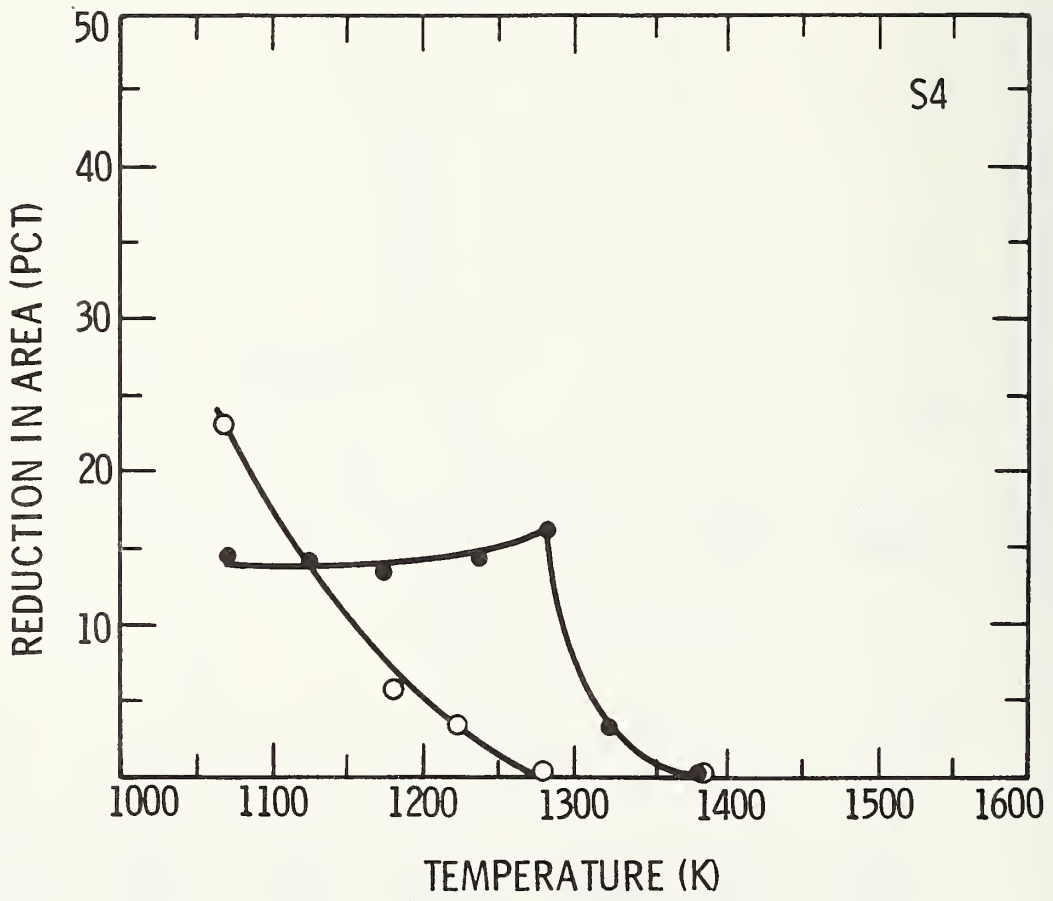

FIG. 13(c). SAME AS (A) FOR ALLOY S-4 - REF. (21)

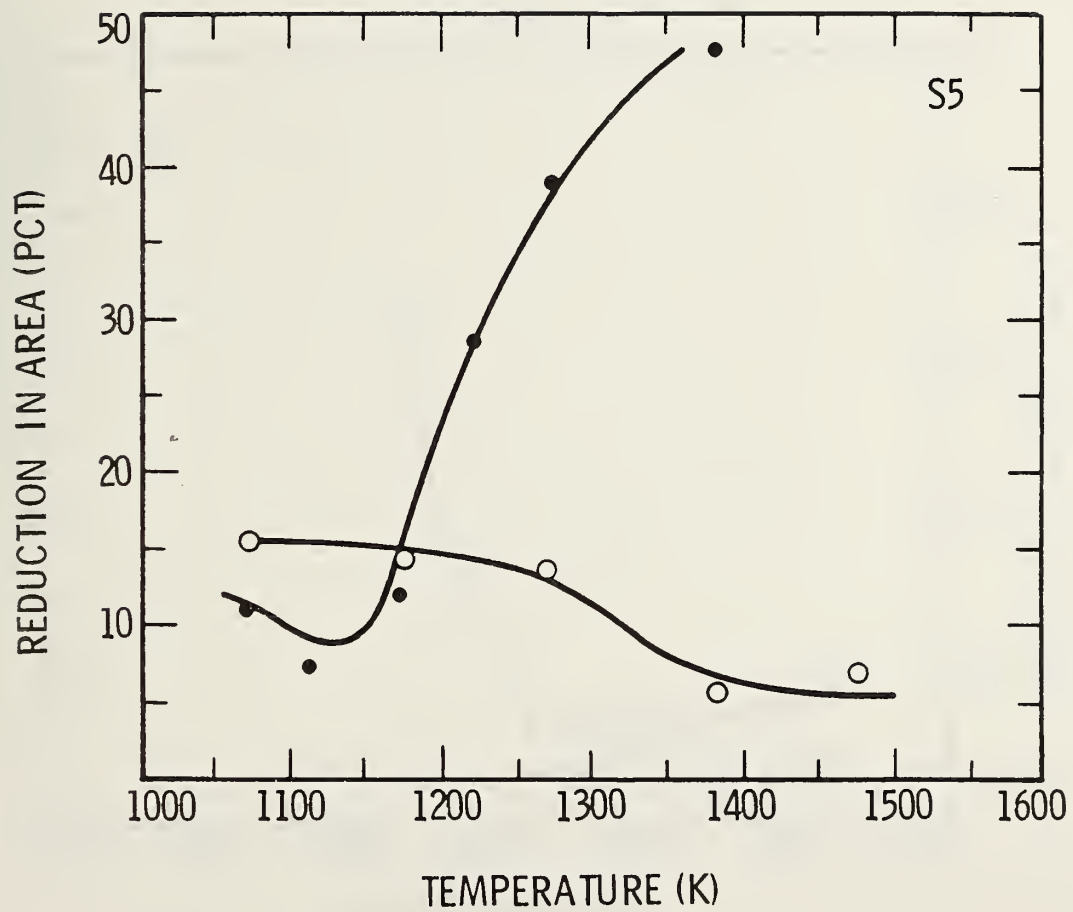

FIG. 13(D), SAME AS (A) FOR ALLOY S-5 - REF. (21)

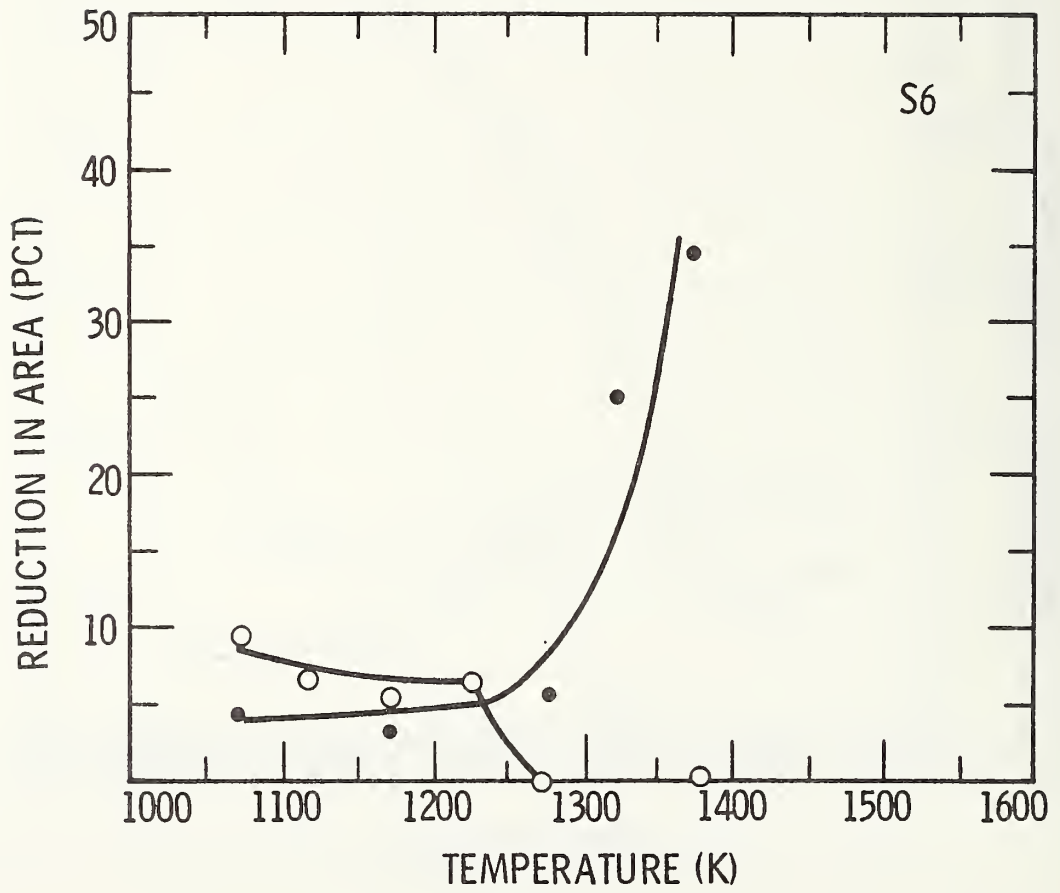

FIG. 13(E). SAME AS (A) FOR ALLOY S-6 - REF. (21)

SUBSTITUTE STAINLESS STEELS WITH LESS CHROMIUM

Joseph A. Douthett
Armco Inc.

SUBSTITUTE STAINLESS STEELS WITH LESS CHROMIUM

BY

JOSEPH A. DOUTHETT
SENIOR RESEARCH ENGINEER
ARMCO INC.

TO BE PRESENTED AT THE

WORKSHOP ON CONSERVATION AND
SUBSTITUTION TECHNOLOGY FOR
CRITICAL MATERIALS

JUNE 15-17, 1981
VANDERBILT UNIV. - NASHVILLE

(ORAL & WRITTEN
PRESENTATIONS)

STEEL ANALYSTS PREDICT THE STAINLESS INDUSTRY TO BE ONE OF THE FASTER GROWING SEGMENTS OF THE AMERICAN STEEL MARKET. AS A STAINLESS PRODUCER, ¹ WE AT ARMCO ARE KEENLY AWARE OF THE DEPENDENCE WE AS A COMPANY AS WELL AS A NATION HAVE ON FOREIGN SOURCES OF SUPPLY FOR OUR CHROMIUM. WE HAVE SEEN THE CHARTS ² SHOWING OUR GREATER THAN 90% RELIANCE ON COUNTRIES LIKE SOUTH AFRICA, RUSSIA AND ZIMBABWE. WE VIEW WITH ALARM, ³ PROJECTED U.S. DEMANDS FOR CR WHICH WILL MORE THAN DOUBLE BY THE YEAR 2000. OUR PREDICAMENT IS FURTHER EMPHASIZED BY COMPARING THE U.S. VS. THE WORLD DEMAND FOR CR AGAIN THROUGH 2000 ⁴. WITH NO RESERVES, WE WILL STILL ATTEMPT TO CONSUME OVER 20% OF THE PREDICTED WORLD NEED. WITH SOME METALS, A SECONDARY SUPPLY SOURCE COMES IN THE WAY OF RECYCLED SCRAP. ⁵ WITH CR ONLY 10 % OF OUR U.S. SUPPLY CAN BE GAINED VIA THIS ROUTE.

BEING A CR "HAVE-NOT" NATION, WE NATURALLY LOOK TO WHO CONTROLS THE AVAILABLE SUPPLY. A TABLE ⁶ OF LEADING PRODUCERS POINTS OUT THE RATHER PRECARIOUS LOCATIONS OF RICH DEPOSITS. OUR NEEDED CR IS CONTROLLED BY "UN" COUNTRIES: ⁷

UNSTABLE
UNFRIENDLY
UNDERDEVELOPED

SUCH COUNTRIES ARE PRIME CANDIDATES TO CARTEL THE WORLD'S CHROMIUM. RUSSIA IS PRESENTLY ACTIVELY PROMOTING SUCH A PLAN TO TURKEY AND ZIMBABWE.

THE STAGE FOR SUCH A CARTEL IS EVEN FURTHER SET BY REVIEWING STEEL ALLOYING ELEMENT PRICE TRENDS FOR THE LAST 5 YEARS. ⁸ OF THE COMMON ELEMENTS, ALL HAVE OUTSTRIPPED CR. LIKE 30¢/GALLON GASOLINE, LOW PRICED READILY AVAILABLE CR DESTROYS THE INCENTIVE TO DEVELOP ALTERNATIVES. THE ECONOMIC IMPORTANCE OF CR IS FURTHER EMPHASIZED ^a BY REVIEWING THE COST/LB. OF COMMON STEEL MELT ADDITIONS. FOR WHAT IT DOES FROM A CORROSION AND OXIDATION RESISTANCE STANDPOINT, CR IS THE MOST COST EFFECTIVE STEEL ALLOYING ELEMENT AVAILABLE. AS BUREAU OF MINES EXPERT JOHN MORNING ¹⁰ PUT IT, "THERE IS NO KNOWN SUBSTITUTE FOR CHROMIUM IN STAINLESS STEELS". TO REPLACE CR IT WOULD MOST LIKELY COST THE CONSUMER MONEY. WITH NO IMPENDING CUTOFF, CUSTOMERS WILL NOT PAY MORE SIMPLY TO CONSERVE CR, EVEN IF THE PROPERTIES OF A REPLACEMENT ALLOY ARE EQUIVALENT.

DUE TO ECONOMICS AND LACK OF AN AVAILABLE SUBSTITUTE, AMERICAN INDUSTRY HAS BEEN CONDUCTING PROGRAMS OF PARTIAL REPLACEMENT FOR CR. LET'S REVIEW SOME OF THESE INDUSTRY APPROACHES AND THEN CHECK SEVERAL ARMCO IDEAS.

NASA ¹¹ HAS EXAMINED PARTIAL CR REPLACEMENT WITH MN, SI, AL, AND MO. WHILE 33% OF THE CR CAN BE SAVED, THE ALLOYS HAVE DEFINITE PRODUCTION AND ECONOMIC PROBLEMS. HOWEVER, SUCH ALLOYS DO PERMIT SHIFTING THE STRATEGIC METAL PROBLEM FROM CR TO AL, MN, MO, OR NI.

R. A. LULA OF ALLEGHENY LUDLUM REVEALED A SERIES OF CR CONSERVING AUSTENITICS ¹² THAT ALLOWED 35% OF THE CR IN T304 TO BE REPLACED BY MN AND N. ECONOMICALLY, A PROMISING TRADE OFF ALTHOUGH QUESTIONABLE FROM A CORROSION STANDPOINT.

MR. LULA FURTHER STATED IN HIS 1979 "METAL PROGRESS" ARTICLE THAT STAINLESS CLAD HAD POTENTIAL. ¹³ NOTE HERE THE CR AND NI SAVINGS THAT T304 CLAD ONTO 409 WOULD GIVE. A 409 CORE ALSO GREATLY ELIMINATES EDGE CORROSION SEEN WITH MOST COATED OR CLAD STEELS. CLADDING ECONOMICS STILL REMAINS A PROBLEM AS WOULD WELDING.

PARTIAL CR ¹⁴ REPLACEMENTS HAVE BEEN AND ARE PRESENTLY BEING STUDIED AT ARMCO. A GREAT DEAL OF EFFORT HAS BEEN EXPENDED ON CR CONSERVING ALLOYS FOR THE AUTOMOTIVE INDUSTRY. AS A STAINLESS PRODUCER, DETROIT IS AN EXCITING BUT UNNERVING PLACE TO VISIT. LET ME SHOW YOU.

STAINLESS STEEL FIRST FOUND AN AUTOMOTIVE HOME IN THIS THE CATALYTIC CONVERTER. ¹⁵ JUST ABOUT ANY CAR MADE IN THE 70'S HAS ONE. THERE MAY BE FROM 8-20# OF STAINLESS PREDOMINATELY 12%CR T409 IN YOUR CONVERTER. MULTIPLY ¹⁶ THIS BY THE NUMBER OF VEHICLES AND YOU HAVE A SINGLE INDUSTRY CONSUMING 11,000 TONS OF CR ANNUALLY.

HOWEVER, IT SEEMS THE CONVERTER WAS JUST THE START OF THE STAINLESS INVASION OF THE AUTOMOTIVE EXHAUST SYSTEM. ¹⁷ NOW, DETROIT FACES SHAVING WEIGHT TO MEET MANDATED FUEL ECONOMIES. SMALL ENGINES MAY RUN HOTTER. HERE COMES MORE POTENTIAL STAINLESS APPLICATIONS. SHEET METAL MANIFOLDS ARE PREDICTED TO GO ACROSS THE BOARD IN SEVERAL YEARS. THESE MANIFOLDS MAY BE TUBULAR ¹⁸ OR STAMPED. ¹⁹

THE ALL STAINLESS EXHAUST ²⁰ IS UNDER STUDY. TWO CAR MODELS AT G.M. WILL GO TO A PREDOMINATELY 409 MUFFLER NEXT YEAR. MEDIUM OR HEAVY DUTY GASOLINE TRUCKS ²¹ NOW OR WILL NEED CATALYTIC CONVERTERS. PARTICULATE TRAPS ²² ARE BEING DESIGNED FOR DIESEL ENGINES.

THUS, TO MAKE A LONG STORY SHORT, STAINLESS CONSUMPTION IN DETROIT COULD MORE THAN DOUBLE WITHIN THE NEXT 5 YEARS. NOW CARS ARE CRITICAL TO OUR DAILY LIVES, BUT DO NOT REQUIRE THE CR AS CRITICALLY AS DO OUR AIRCRAFT ENGINES OR PETROLEUM REFINERIES. CHROMIUM MAY HELP IMPROVE OUR CARS M.P.G. RATING BUT WHAT IF DUE TO A LACK OF CR WE CAN'T REFINE THE OIL TO MAKE THE GASOLINE.

AS A STEEL CORPORATION, WE ARE TORN. ²³ PART OF US WANTS TO SELL DETROIT, THE COUNTRY'S BIGGEST STEEL USER ALL THE STAINLESS IT WANTS. THE OTHER PART OF US LOOKS DOWNSTREAM AND URGES CR CONSERVING ALTERNATIVES BE DEVELOPED. BOTH SCENARIOS ARE BEING PURSUED.

WHEN DETROIT CAME LOOKING FOR TRUCK CONVERTER MATERIALS ²⁴ MORE OXIDATION RESISTANT THAN 409, PAST STAINLESS TECHNOLOGY SAID ADD MORE CR. HOWEVER, BY USING AL IN SMALL QUANTITIES, OUR OBJECTIVE WAS MET WHILE CONSERVING CR. ADDING AL TO A STAINLESS IS NOT AS EASILY DONE AS CR. ²⁵ WHILE AL DRAMATICALLY IMPROVES OXIDATION RESISTANCE, IT IS DELETERIOUS TO OTHER ESSENTIAL PROPERTIES. A BALANCE MUST BE STRUCK. THE RESULT OF SEVERAL YEARS OF RESEARCH IS A FAMILY OF "SR" (SCALE RESISTANT) ALLOYS.

THESE 2 MATERIALS ²⁶ KNOWN AS 6 AND 12SR ARE DESIGNED TO REPLACE 12 AND 18CR ALLOYS RESPECTIVELY. THE .6%CB ADDITION DRAMATICALLY IMPROVES SHORT TIME CREEP OR SAG RESISTANCE. LIGHTER GAUGE COMPONENTS CAN THEREBY BE DESIGNED.

NOTE THIS BAR CHART SUMMARY ²⁷ OF 6SR AND 12SR CYCLIC OXIDATION RESISTANCE. THESE CR-AL FERRITICS EFFECTIVELY FILL THE GAP BETWEEN 409 AND 18CR ALLOYS. AS FOR CREEP ²⁸ OR SAG RESISTANCE AT TEMPERATURES UP TO 1600F, THESE NEW ALLOYS FAR OUTDISTANCE THEIR PREVIOUS FERRITIC COUNTERPARTS.

WHY DO WE EXPECT THESE ALLOYS TO GO AND NOT THE NASA CR-AL-SI-MO ALLOYS REFERRED TO EARLIER? COST EFFECTIVENESS. ²⁹ THESE ALLOYS WILL GIVE COMPARATIVE PROPERTIES COMPARED TO MORE COSTLY AND HIGHER CR PREDECESSORS.

BESIDES TRUCK CONVERTERS AND LIGHTER GAUGE AUTO CONVERTERS, HERE'S A DIESEL ³⁰ APPLICATION WHERE THE 12%CR-AL ALLOY REPLACED AN 18%CR-10%NI AUSTENITIC WITH NO THICKNESS CHANGE.

THE ABOVE ALLOYS WILL CONSERVE NOT REPLACE CR. AN ALLOY IDEA WHICH COMES MUCH CLOSER IS NP454 ³¹ (NP STANDING FOR NEW PRODUCT). NP454 IS AN ALUMINIZED HOT DIP STEEL WHERE THE SUBSTRATE INSTEAD OF BEING A LOW C STEEL IS A LOW ALLOY VERSION. ADDING CR, AL, TI TO THE BASE METAL INCREASES THE COATED PRODUCT'S UPPER OXIDATION LIMIT TO 1500F VERSUS 1250F. ³² SUCH AN ALLOY COULD REPLACE 409 IN SOME EXHAUST APPLICATIONS AT A LOWER COST AND A SIGNIFICANT SAVINGS IN CR. ALUMINUM COATING ³³ LOW ALLOY AND STAINLESS BASE METALS MAY BE AN ANSWER TO OXIDATION PROBLEMS

WITHOUT INVESTING IN NEW CAPITAL EQUIPMENT.

WHILE ADDING AL AND SI TO STAINLESSES, ³⁴ HOW ABOUT AN AUSTENITIC. IN1212 IS AN INTERNATIONAL NICKEL ALLOY DESIGNED TO CONSERVE CR AND REPLACE T309 OR T310 STAINLESS. OXIDATION TESTS ³⁵ SHOW THIS MATERIAL A PROMISING HIGH TEMPERATURE CANDIDATE.

WHILE CONSERVING CR IN T304, LET'S TRY A DIFFERENT APPROACH BY OFFERING A COMPLETELY REDESIGNED COMMODITY AUSTENITIC STAINLESS. NP599 ³⁶ IS A 16%CR, 8%Mn, 2.25%Ni AUSTENITIC WHICH USES Mn, N AND CU TO REPLACE COSTLY Ni WHILE QUIETLY CONSERVING 2%CR. WHILE NOT QUITE AS CORROSION RESISTANT AS T304 ³⁷, NP599 OFFERS BETTER STRENGTH AND A COST INDUCEMENT. THE OBJECTIVE OF NP599 IS NOT TO OFFER A LOWER CORROSION RESISTANT T304 BUT TO PROVIDE A COST EFFECTIVE MATERIAL ALTERNATIVE TO APPLICATIONS WHERE T304 IS ALREADY AN OVER-DESIGN. CR CONSERVATION IS AN UNWRITTEN SIDE BENEFIT.

HOW ABOUT A CORROSION HEAVY WEIGHT? ³⁸ ARMCO'S NITRONIC 50 EFFECTIVELY COMPETES FROM A CORROSION AND PRICE STANDPOINT WITH MUCH HIGHER Ni, Mo AUSTENITICS BY USING N TO AID IN PITTING RESISTANCE. REPLACING Mo WITH N ALSO LIMITS THE AMOUNT OF Ni NEEDED AS N IS A POWERFUL AUSTENITE STABILIZER.

FINALLY, ³⁹ I GIVE YOU NITRONIC 60, A 4% Si AUSTENITIC DEVELOPED FOR GALLING AND WEAR TESTS. TESTS LIKE THESE ⁴⁰ INDICATE THAT SOME APPLICATIONS MAY ALLOW US TO USE AN Fe BASE STAINLESS FOR HIGH Co MATERIALS.

THIS PRETTY MUCH SUMMARIZES THE KIND OF MATERIAL CONSERVATION RESEARCH BEING DONE AT ARMCO. ⁴¹ PERHAPS IT'S APPARENT THAT IN A TIME OF READILY AVAILABLE CR, THE ONLY CONSERVING THAT CAN BE DONE IS A PARTIAL REPLACEMENT IN STAINLESS ALLOYS OR THE DEVELOPMENT OF LOW CR COATED MATERIALS. HOWEVER, FOR THESE TO BE EFFECTIVE, A COST ADVANTAGE INDUCEMENT MUST BE BUILT-IN. WHILE MATERIAL INERTIA FIGHTS US IN EXISTING MARKETS, LET'S HOPE EMERGING HIGH ALLOY MARKETS CAN BE GUIDED TOWARD STRATEGIC MATERIAL CONSERVING ALLOYS.



U.S. IMPORT RELIANCE FOR SOME IMPORTANT METALS

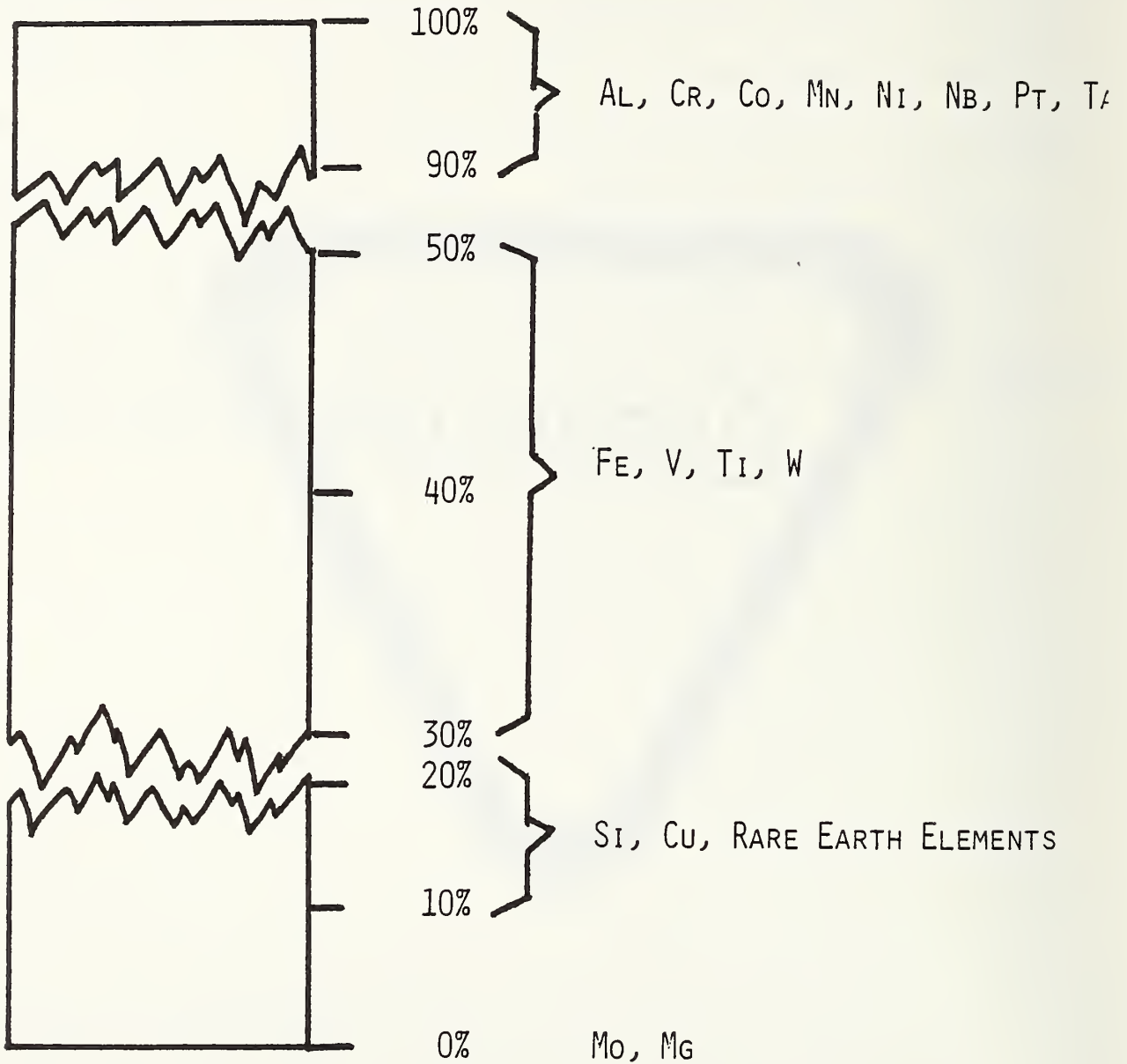

SOURCE: CANNON MUSKEGON CORP.

PROJECTED U.S. DEMAND FOR CR

<u>YEAR</u>	<u>DEMAND (1000 TONS)</u>
1976	461
1985	670
2000	1100

SOURCE: US BUREAU OF MINES

CUMULATIVE U.S. AND WORLD DEMAND/RESERVES FOR CR
YEAR 1976-2000

(MILLION TONS)

	<u>U.S.</u>	<u>WORLD</u>
DEMAND	20	87
RESERVES	<.1	830

SOURCE: U.S. BUREAU OF MINES

SCRAP AS A SECONDARY SOURCE
OF THE U.S. METAL SUPPLY

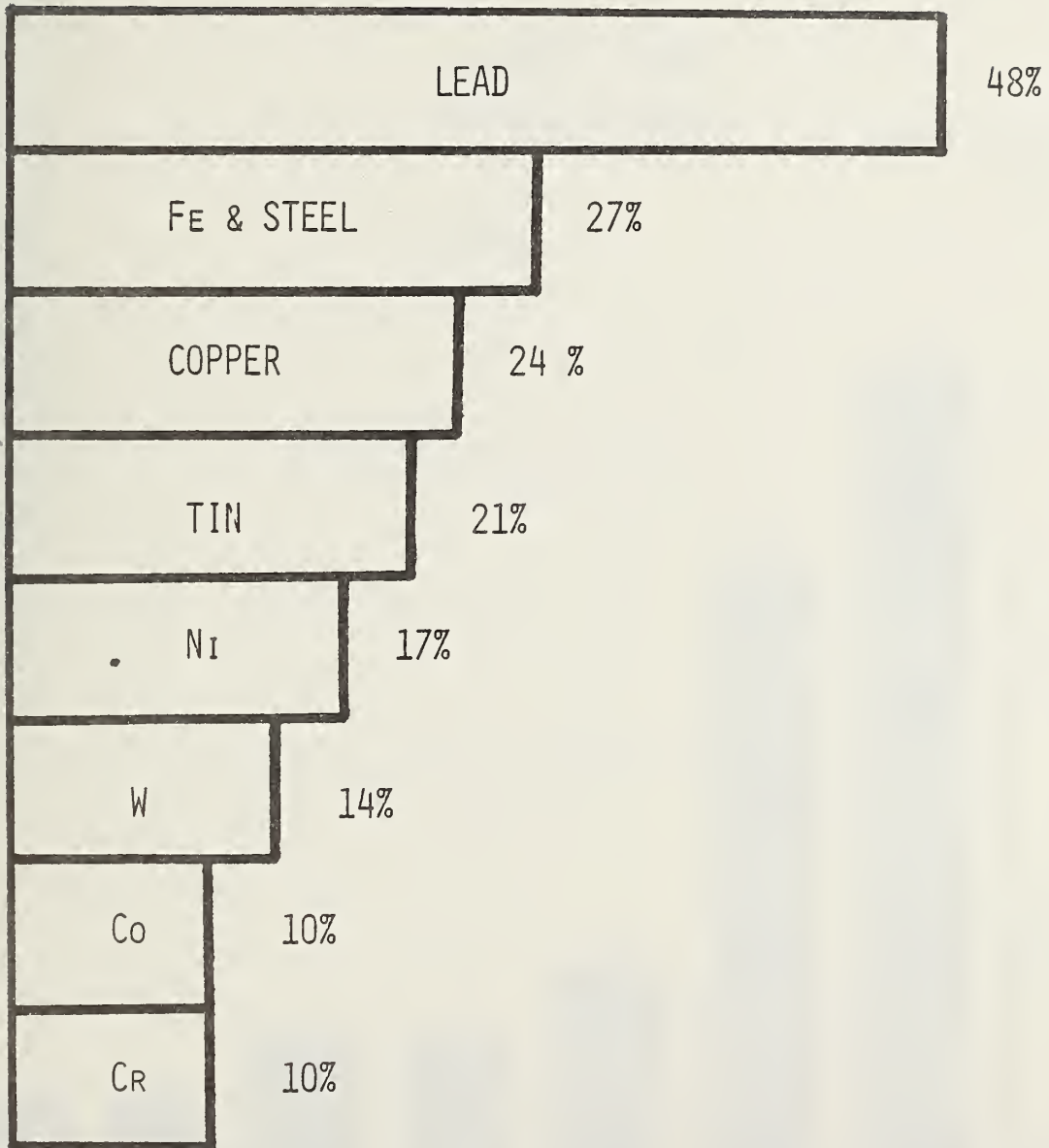

SOURCE: NETSCHERT, "JOURNAL OF METALS", MARCH 81

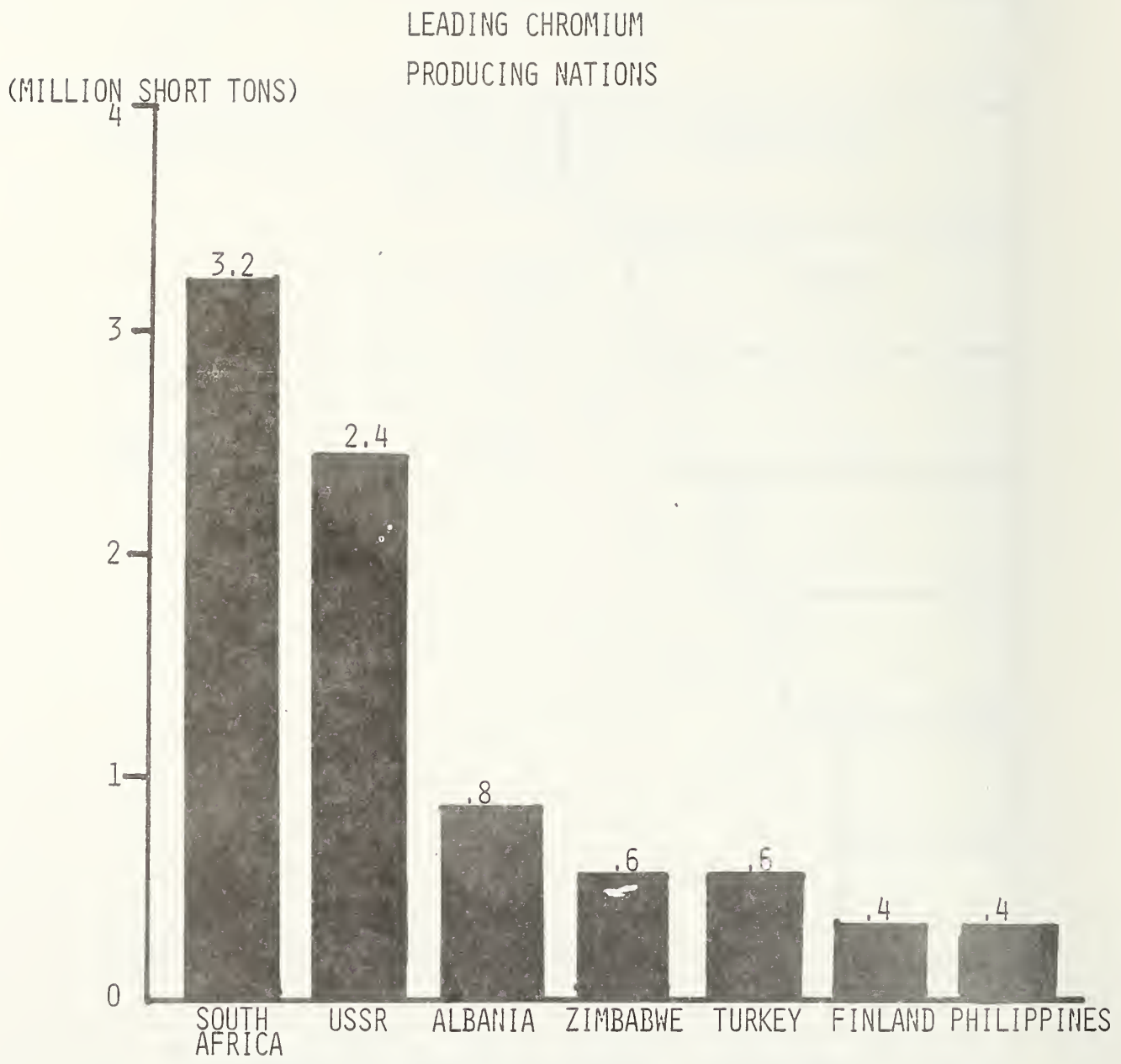

SOURCE: B. NETSCHERT, "JOURNAL OF METALS", MARCH 81

" UN "

UNSTABLE

UNFRIENDLY

UNDERDEVELOPED

METAL PRICE TRENDS 1975-1980

	<u>% INCREASE</u>
CR	112
MN	115
CU	145
NI	146
FE	153
TI	290
MO	310
CO	625

Reliance vs Cost

<u>Mineral or Metal</u>	<u>Import Reliance*</u>	<u>Raw Matl** Cost/lb</u>
Columbium	100%	\$ 6.20
Manganese	97%	\$.40
Cobalt	95%	\$21.00
Aluminum	93%	\$.73
Chromium	91%	\$.50
Nickel	78%	\$ 3.40
Titanium	42%	\$ 1.50
Iron	29%	\$.05
Copper	20%	\$.85

* A. G. Gray, "Metal Progress", Feb. 50

** Approx. Cost As Additions To Steel

**“There is no known substitute
for chromium in
Stainless Steel.”**

Lower Cr T304 Alloys*

NASA

Alloy	%Cr	%Ni	%Mn	%Si	%Al	%Mo
Regular T304	18	8	1.1	.6	—	—
12 Cr-Si (Ferritic)	12	8	1.1	2.6	—	—
12 Cr-Al-Mo (Ferritic)	12	8	1.1	.6	2	2
12 Cr-Si (Aust.)	12	10	1.1	3.6	—	—
12 Cr-Al-Mo (Aust.)	12	10	5.1	1.6	2	2

*B. LeCarré, "Iron Age", May 23, 1970

Lower Cr T304 Alternatives*

<u>Alloy</u>	<u>%C</u>	<u>%Mn</u>	<u>%N</u>	<u>%Ni</u>	<u>%Cr Savings</u>
Regular T304	.06	1.7	.05	8.75	—
16% Cr Alloy	.07	3.1	.075	"	13.5%
14% Cr Alloy	.07	5.3	.075	"	25 %
12% Cr Alloy	.07	4.8	.15	"	35 %

*Lula, "Metal Progress", Oct. 79

Conserving Cr & Ni by Cladding*

Clad	T304	Composite	Savings vs T304	
<u>Thickness</u>	<u>Thickness</u>	<u>Cr Content</u>	<u>Cr</u>	<u>Ni</u>
.100"	.0016"	11.08%	40 %	98.5%
.100"	.0032"	11.23%	37.5%	96.5%
.100"	.0065"	11.46%	36 %	93.5%

409 is the core material.

*Lula, "Metal Progress", Oct. 79

**ARIMCO
ALTERNATES**



1981

Automotive Usage

409 Stainless

100,000 Tons Metal Consumed

11,000 Tons Cr Consumed



P10-25

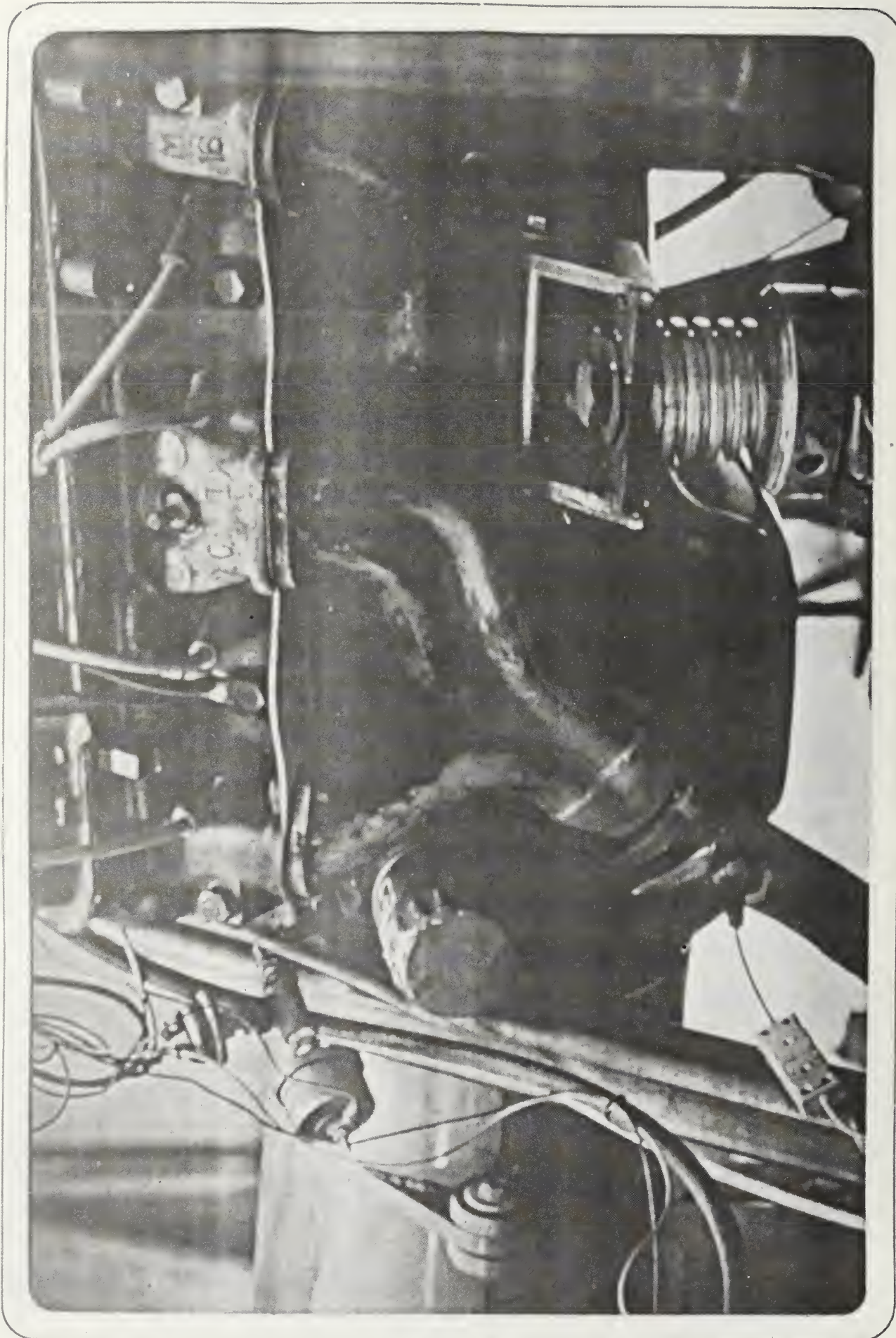

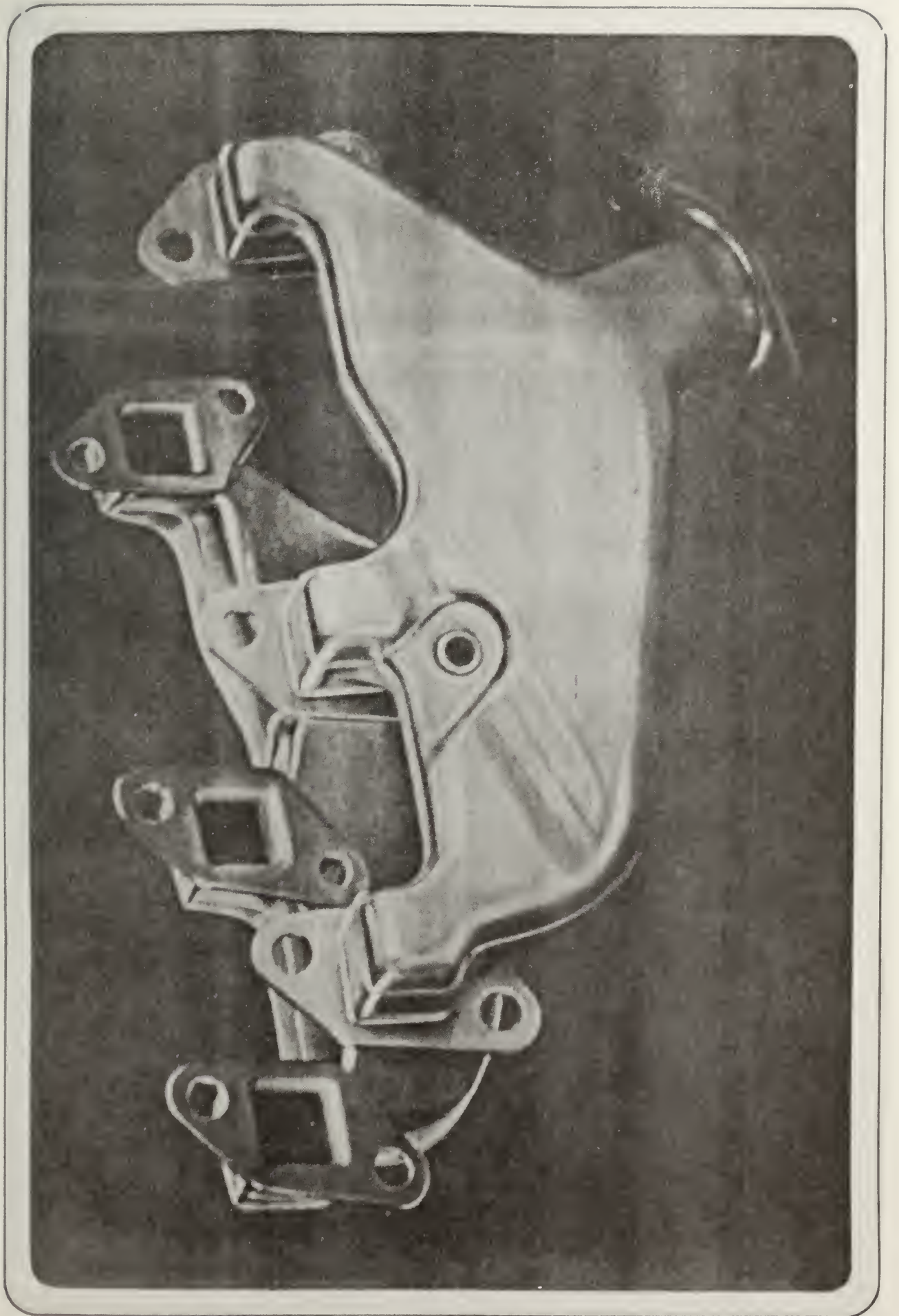

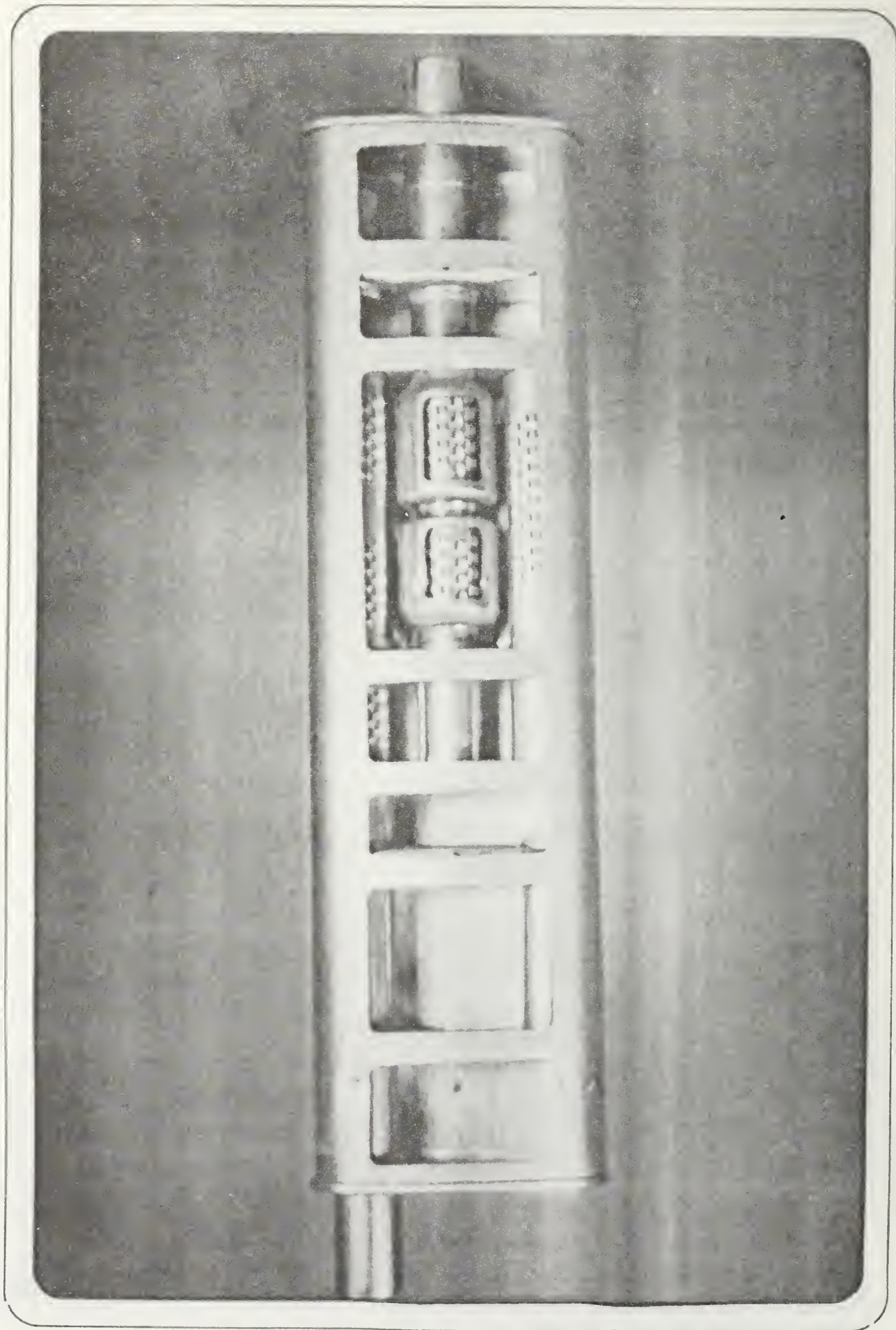

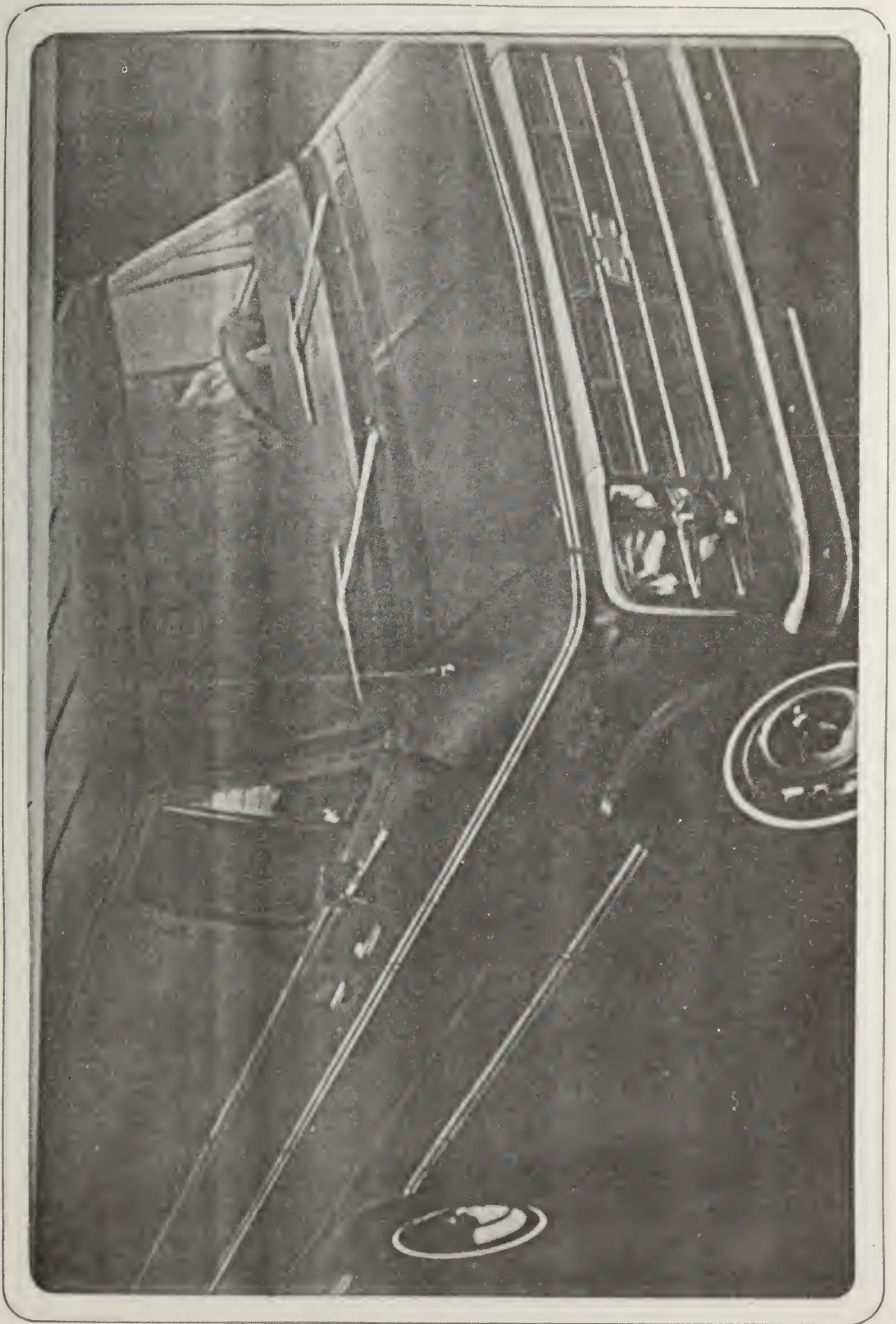

P10-29

Artist's Concept of Diesel Particulate Trap

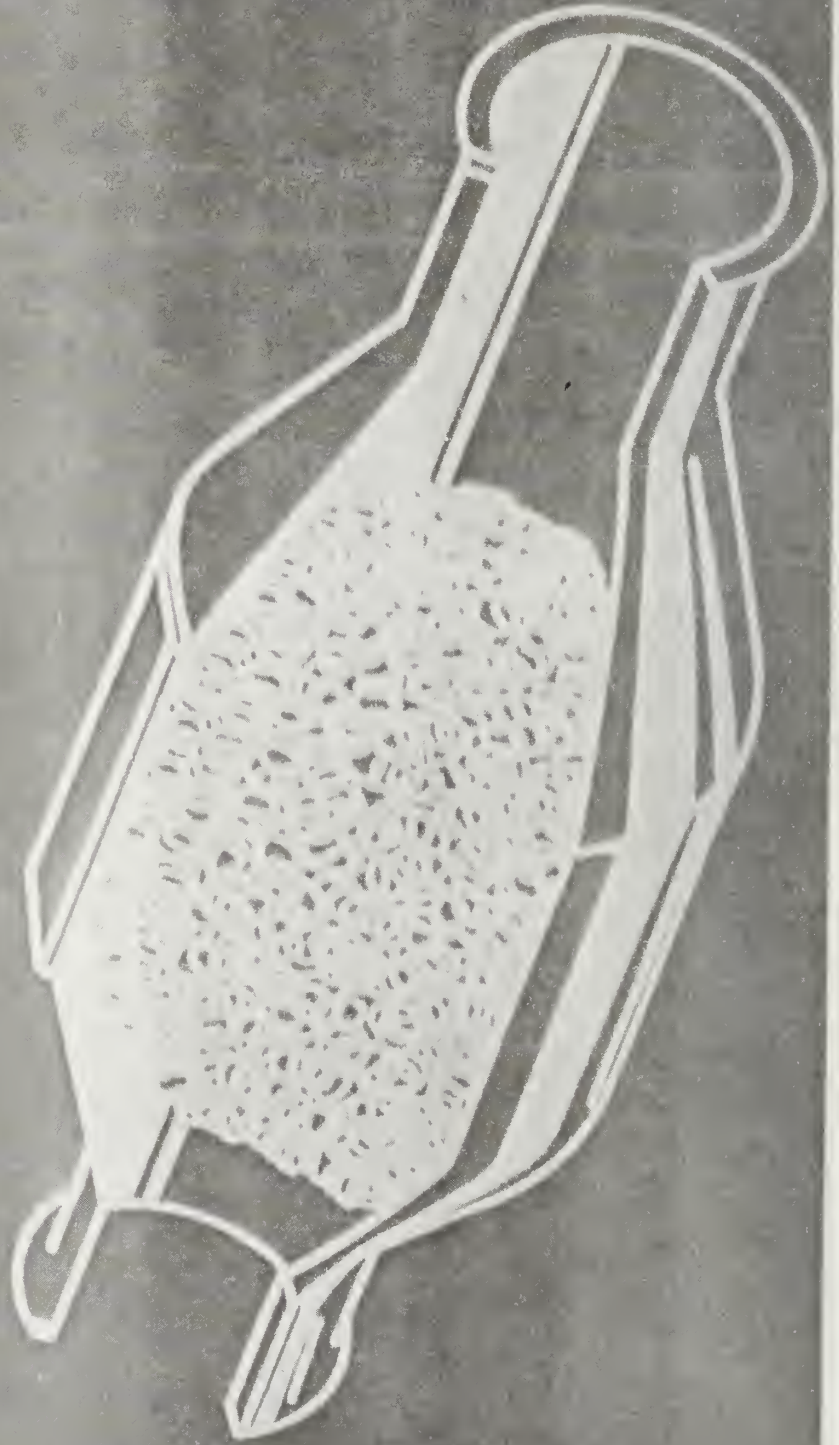

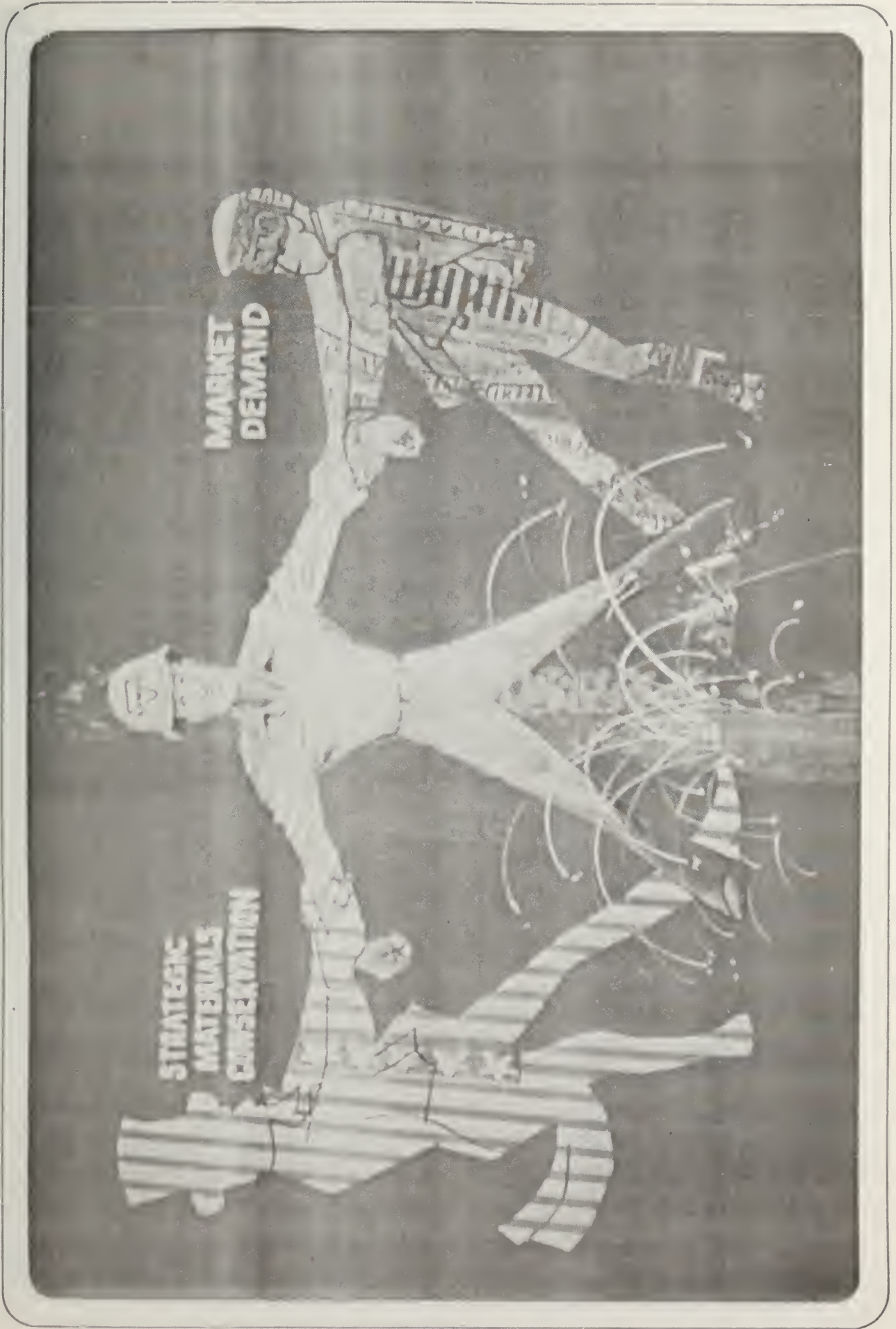

Effect of Chromium Content
on Scaling Resistance
of Chromium-Iron Alloys
(At 1300°C)

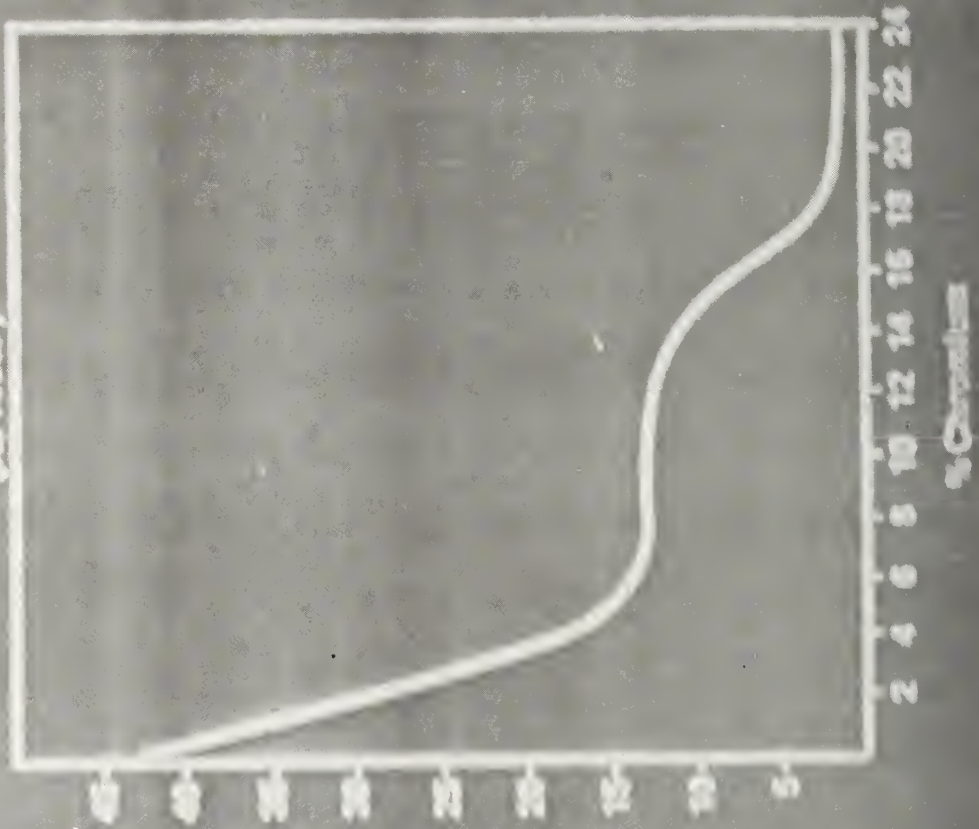

Scaling -
% weight loss

% Chromium

Al in Stainless Steels

Oxidation Resistance

+++

Corrosion Resistance

0

Formability

—

Toughness

Weldability

Producibility

+ positive effect

0 no effect

— negative effect

"SR" Alloys Chemistry

	<u>%C</u>	<u>%Cr</u>	<u>%Al</u>	<u>%Ti</u>	<u>%Cb</u>	<u>%Mo</u>
6SR	.02	6.6	1.2	.3	.6	—
409	.04	11.0	—	.4	—	—
12SR	.02	12.0	1.2	.3	.6	—
18Cr-2Mo	.02	18.5	—	.3	.7	2.25

Alloy Comparisons Oxidation Resistance

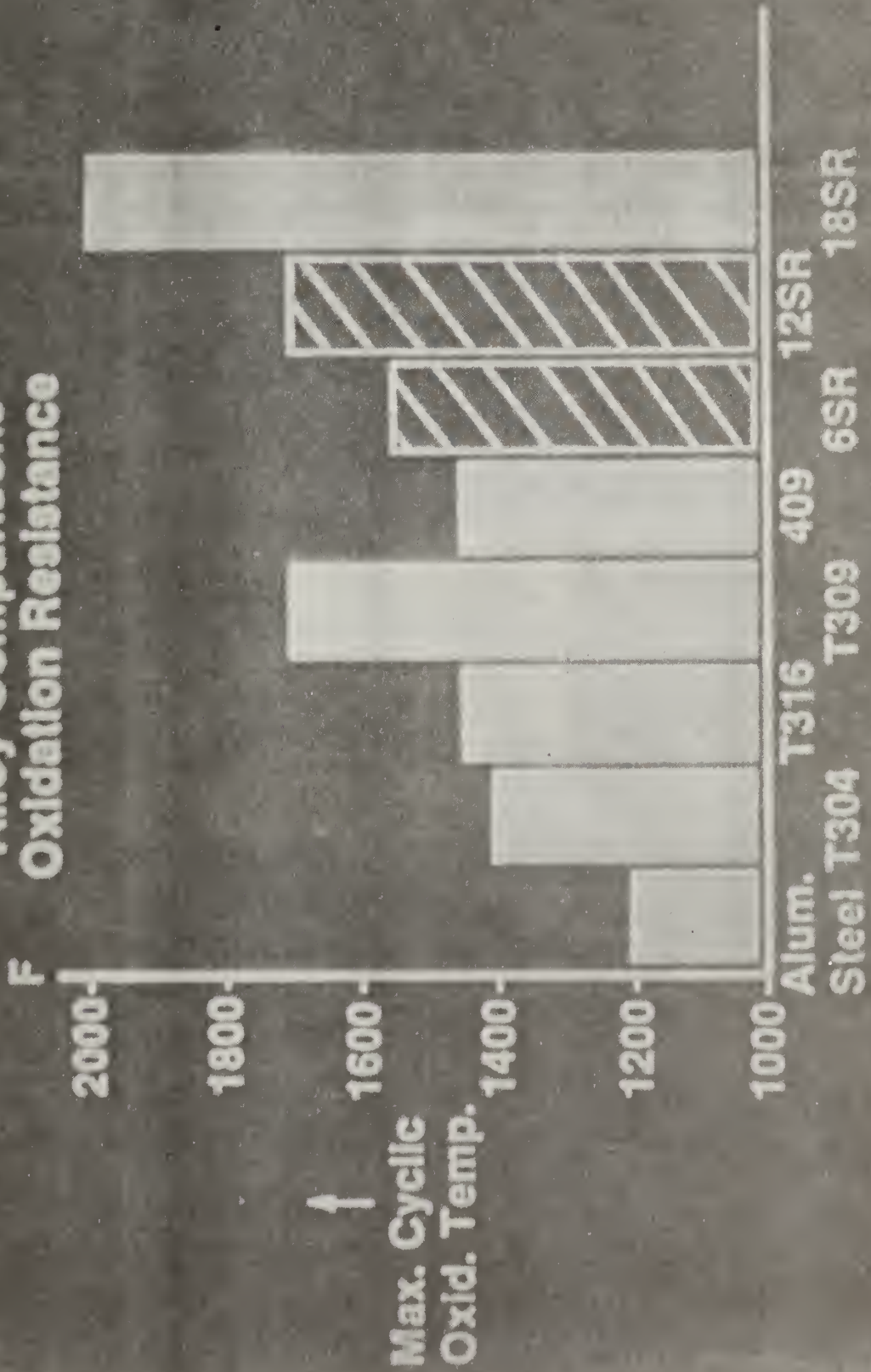

Alloy Comparisons Sag or Creep

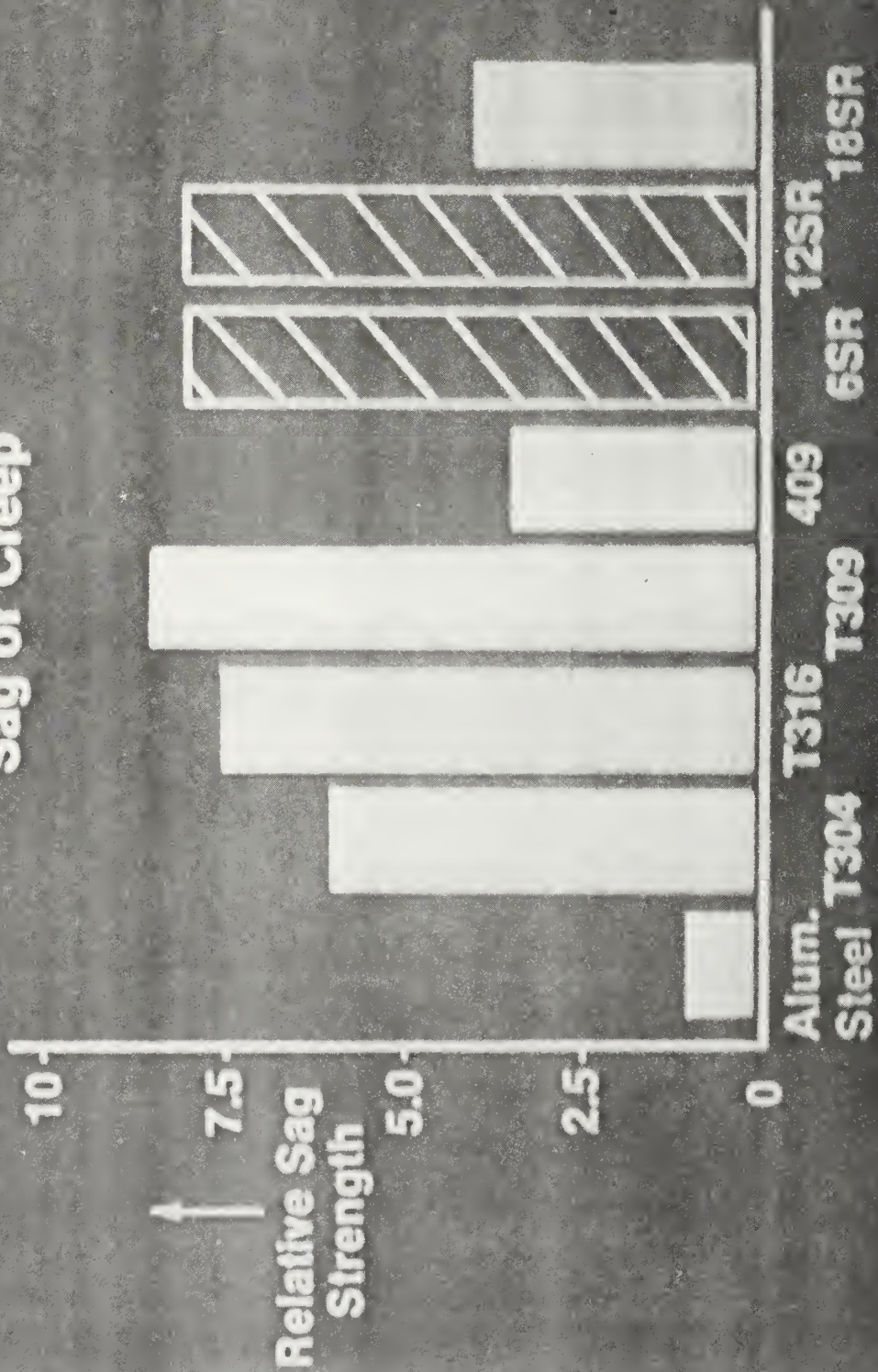

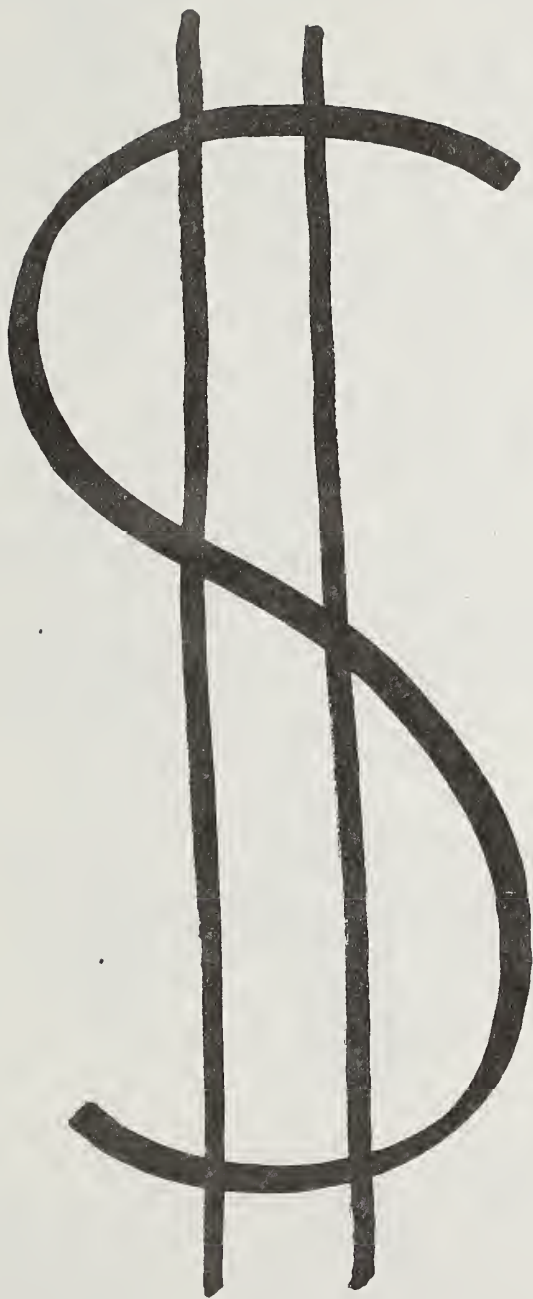



P10-38

Low Alloy Aluminized Steel

	<u>%C</u>	<u>%Cr</u>	<u>%Si</u>	<u>%Al</u>	<u>%Ti</u>
NP454	.04	2.0	.6	1.7	.4
409	.04	11.0	.5	—	.4

CYCLIC OXIDATION TESTS - K60U-F

CYCLE: 25 MINUTES IN ELEMENT 5 MINUTES OUT

1954-4
1954

1954-4
1954

1954-4
1954



50 CYCLES

250 CYCLES

550 CYCLES

Oxidation Temp. vs. Alloy

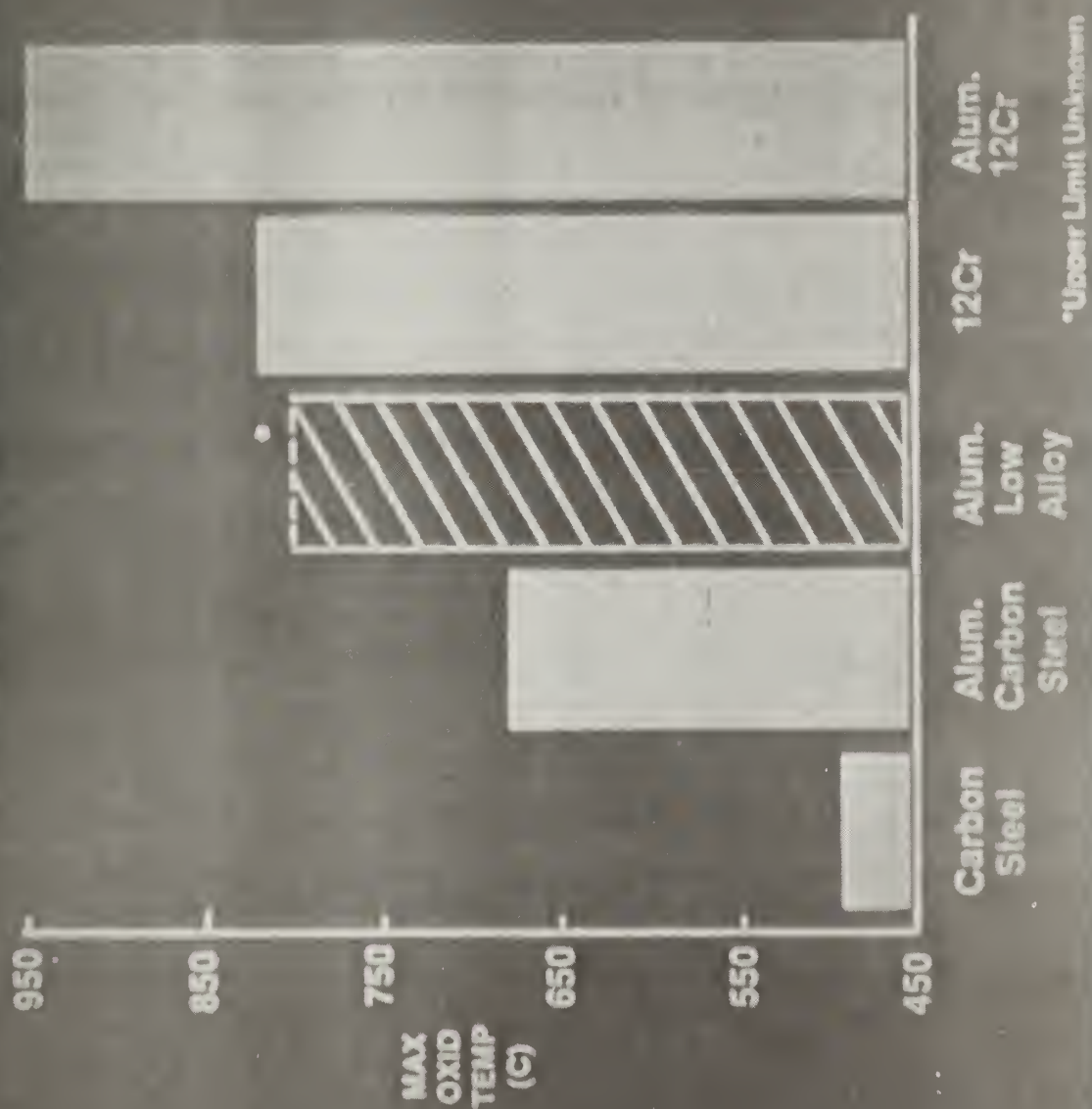

High Temperature Cr-Ni Stainless

	<u>%C</u>	<u>%Cr</u>	<u>%Ni</u>	<u>%Si</u>	<u>%Al</u>
IN1212	.07	12.5	12.5	2.0	1.75
T304	.06	18.0	9.0	.5	—
T309	.10	22.5	13.5	.5	—
T310	.06	25.0	20.0	.5	—

OXIDATION RESISTANCE

Descaled Weight Loss, MG/CM²

Gasoline Engine Exhaust (102 Hrs. Cyclic¹)

1500°F

1800°F

T-304 196 (60 Hrs. Only)

489 (18 Hrs. Only)

T-309 81

108

T-310 57

67

IN-1212 1

20-92

TYPICAL CHEMISTRY

NP599

COMMODITY AUSTENITIC

	<u>%C</u>	<u>%MN</u>	<u>%SI</u>	<u>%CR</u>	<u>%NI</u>	<u>%CU</u>	<u>%N</u>
NP599	.035	8.0	.50	16.0	2.25	.75	.20
T304	.060	1.5	.50	18.3	8.50	.20	.03

NP599 vs. T304

	<u>NP599</u>	<u>T304</u>
STRENGTH	✓	
CORROSION RESISTANCE		✓
COST	✓	
CR CONSERVATION	✓	

✓ - DENOTES COMPARATIVE ADVANTAGE

Substitutions for Mo & Ni

	<u>%Cr</u>	<u>%Mn</u>	<u>%Ni</u>	<u>%Mo</u>	<u>%Cu</u>	<u>%N</u>
UDM904L	20	1.5	25	4.25	1.75	—
Al-6X	20	1.5	25	6.0	—	—
Nitronic 50	22	5.0	13	2.2	—	.30
317Lt	19	1.5	14	4.0	—	.06

TYPICAL COMPOSITION

Armco Nitronic 60

Carbon	0.10% Max.
Manganese	7.00-9.00
Silicon	3.50-4.50
Chromium	16.00-18.00
Nickel	8.00-9.00
Nitrogen	.08-.18

WEAR RESISTANCE OF NITRONIC 60

0.5 INCH (1.27 CM) CROSSED CYLINDERS
SELF-MATED
315 RPM (276 CM/SEC)
15 LBS (173 KG) LOAD
DRY

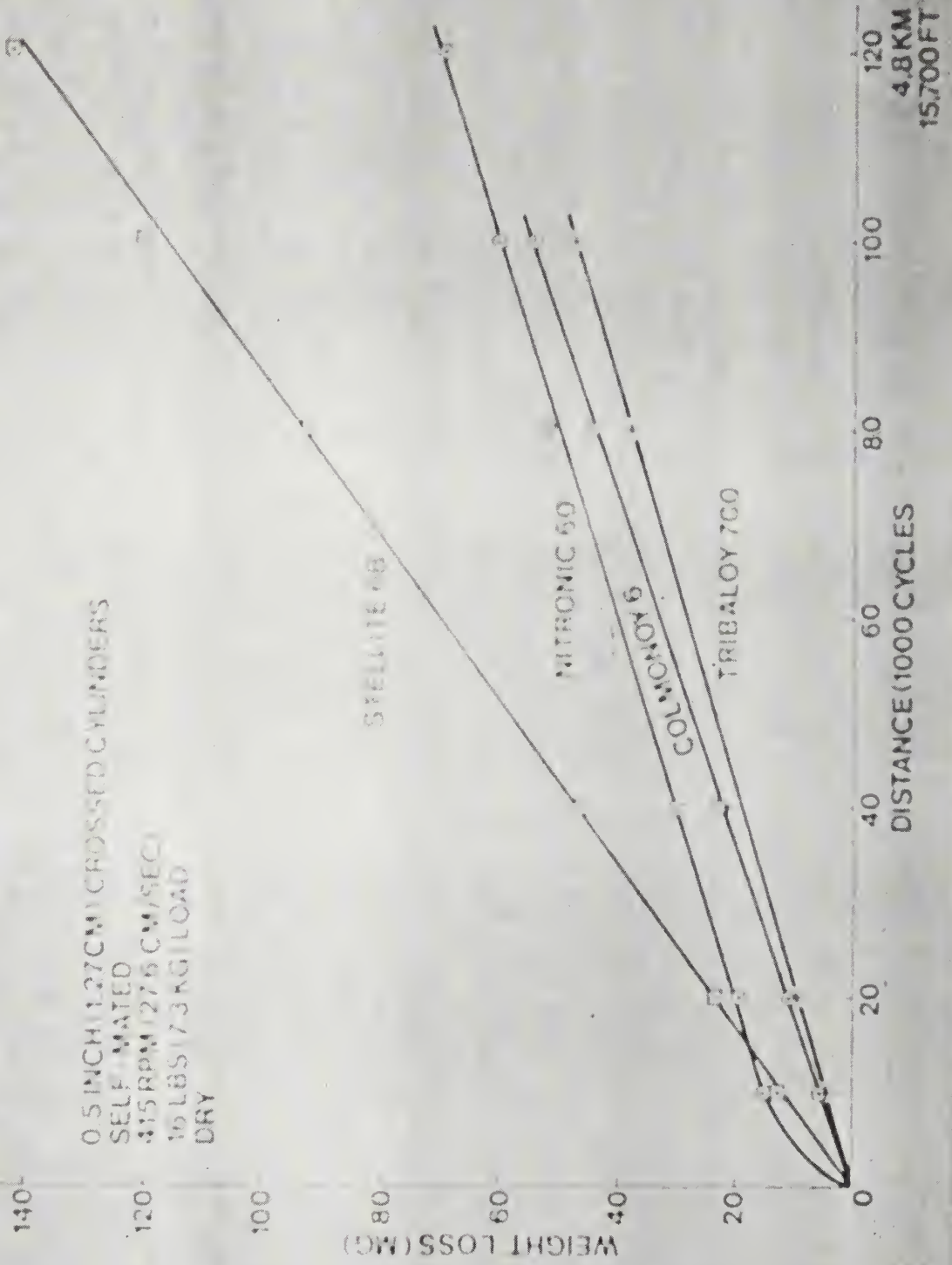

- **Producible**

- **Consumer Usability**

- **Cost Effectiveness**

SUBSTITUTION OF MODIFIED 9CR-1MO STEEL
FOR AUSTENITIC STAINLESS STEELS

Vinod Sikka
Oak Ridge National Laboratory

SUBSTITUTION OF MODIFIED 9 Cr-1 Mo STEEL
FOR AUSTENITIC STAINLESS STEEL*

V. K. Sikka

Paper to be presented at
Workshop on Conservation and Substitution
Technology for Critical Materials

Vanderbilt University
Nashville, Tennessee

June 15-17, 1981

*Research sponsored by the Office of Reactor Research and
Technology, U.S. Department of Energy, under Contract W-7405-eng-26
with the Union Carbide Corporation.

By acceptance of this article, the
publisher or recipient acknowledges
the U.S. Government's right to
retain a nonexclusive, royalty-free
license in and to any copyright
covering the article.

SUBSTITUTION OF MODIFIED 9 Cr-1 Mo STEEL
FOR AUSTENITIC STAINLESS STEEL*

V. K. Sikka

ABSTRACT

This paper describes the current program to develop a high strength ferritic-martensitic steel. The alloy contains Fe-9% Cr-1% Mo with small additions of V and Nb and is known as modified 9 Cr-1 Mo. Its elevated-temperature properties and design allowable stresses match those of type 304 stainless steel for temperatures up to 600°C and exceed other ferritic steels by factors of 2 to 3. The improved strength of this alloy will permit its use in place of stainless steels for many applications. We expect this possible substitution to reduce the demand for imported chromium.

INTRODUCTION

Chromium is an essential constituent in alloys used in oil refining, petrochemical plants, conventional and nuclear power plants, tanker trucks, gas turbines, industrial machinery, and all stainless steel applications where high elevated-temperature strength and corrosion resistance are required. Yet our major sources of supply are South Africa and the Soviet Union, and in 1980 we imported 91% of the chromium we required. The United States is currently following a policy of stockpiling critical elements; however, the stockpile of chromium is

*Research sponsored by the Office of Reactor Research and Technology, U.S. Department of Energy, under Contract W-7405-eng-26 with the Union Carbide Corporation.

180,000 tons short¹ of a stockpile goal of 1.35 million tons. The long-term solution to the critical element (Pt group, Cr, Co, Mn, and Ta) shortage is increased metallurgical research that will lead to the development of alloys that will reduce the shortage of these strategic materials. The purpose of this paper is to present the status of development of a modified 9 Cr-1 Mo alloy that can be substituted for stainless steels in many applications and, therefore, will reduce the consumption of chromium.

BACKGROUND

The 300 series austenitic stainless steels are the most common structural materials for elevated temperature service. Typically, they contain 18% Cr and 8% Ni, and they provide good air and steam oxidation resistance. However, they do have problems with stress corrosion cracking in media containing halides. Ferritic steels on the other hand contain much lower chromium and nickel than to stainless steels and are relatively free from stress-corrosion cracking. They do have less oxidation resistance to air and steam. However, there are many applications where ferritic steels of the 9 Cr-1 Mo type would be acceptable if they had sufficient elevated-temperature strength. If their strength were improved, ferritic steels would also provide better resistance to thermal stresses because of their lower expansion coefficient and higher thermal conductivity. Most of all, using an alloy of this type instead of stainless steels would produce a

substantial saving of chromium. The following section describes the properties of the modified 9 Cr-1 Mo alloy and compares them with those of type 304 stainless steel.

RESULTS AND DISCUSSION

Modified 9 Cr-1 Mo steel is strengthened by small additions of vanadium and niobium. The recommended ranges for various elements are as follows:

C	Mn	Si	P	S	
0.08—0.12	0.30—0.50	0.2—0.5	0.02 max	0.01 max	
Cr	Ni	Mo	V	Nb	N
8—9	0.2 max	0.85—1.05	0.18—0.25	0.06—0.10	0.03—0.07

The alloy is currently recommended for use in the normalized and tempered condition (1038°C for 1 h, air cool to room temperature, 760°C for 1 h followed by air cool to room temperature). However, work in progress shows that the desirable elevated-temperature strength may also be obtained in the isothermally annealed condition (1038°C for 1 h, fast cooled to 704°C, held for 24 h, then air cooled to room temperature).

The alloy has been commercially melted by air induction and argon-oxygen deoxidation (AOD) and refined by the electroslag remelting (ESR) process. Ingots have been fabricated into tube, plate, and bar. The fabrication processes used include hot forging, hot rolling, hot extrusion, hot rotary piercing, centrifugal casting followed by cold pilgering and cold drawing. No problems have been encountered during any of these melting and fabrication procedures.

Specimens from commercial heats have been tensile, creep, Charpy impact, and fatigue tested. Tensile data were used to specify the room-temperature values of 414 MPa (60 ksi) and 586 MPa (85 ksi) for yield and ultimate tensile strength, respectively. The request for inclusion of specifications for this alloy in the ASTM Standards book is currently under review by the appropriate committees.

The average and minimum curves defined by average values and average values minus two standard deviations for yield and ultimate tensile strength of standard and modified 9 Cr-1 Mo alloy are plotted as a function of test temperature in Figs. 1 and 2. A minimum curve for modified 9 Cr-1 Mo based on room-temperature specified values are also plotted in these figures. The ASME Code Case N-47 minimum value curve for type 304 stainless steel is also shown for comparison. These curves show the following:

1. The yield strength for both standard and modified 9 Cr-1 Mo steel is significantly above type 304 stainless steel up to 700°C.
2. The ultimate tensile strength of both standard and modified 9 Cr-1 Mo steel is higher than that of type 304 stainless steel for temperatures up to 550°C.
3. The modified alloy shows higher yield and ultimate tensile strength than the standard alloy over the entire temperature range.

The standard 9 Cr-1 Mo data used in Figs. 1 and 2 come from the United Kingdom (UK) and are on material in the normalized and tempered condition. In the United States the annealed condition is typical for standard 9 Cr-1 Mo. Data on modified 9 Cr-1 Mo steel are for the normalized and tempered condition listed above.

Figure 3 illustrates the variation in estimated average 10^4 -h rupture strength with temperature for various materials. Shown for comparison are average values for type 304 stainless steel that were used in the analysis² to calculate the minimum values now given in Code Case N-47. (This time was chosen because it is the longest time for which verifiable strengths can be calculated for all data sets.) The modified 9 Cr-1 Mo alloy is comparable in creep strength to type 304 stainless steel for temperatures up to about 625°C. Above 625°C it begins to fall below the stainless steel in strength. The 12 Cr-1 Mo-V-W-0.2 C (HT9) maintains a strength comparable to stainless steel only up to about 550°C before it drops off to lower values. The 2 1/4 Cr-1 Mo and annealed standard 9 Cr-1 Mo are lowest in strength, and the UK normalized and tempered standard 9 Cr-1 Mo is intermediate. Above about 675°C, however, all these ferritic steels except modified 9 Cr-1 Mo converge to about the same low strength value. Even as high as 700°C the modified alloy remains intermediate between the stainless steel and the other ferritics.

Fatigue data on modified and standard 9 Cr-1 Mo alloy are compared with the average curve for type 304 stainless steel in Fig. 4. The modified 9 Cr-1 Mo data were obtained in both air and vacuum. This figure shows that the high-cycle fatigue properties of modified 9 Cr-1 Mo are an order of magnitude better than those of type 304 stainless steel. Because of its lower thermal expansion and higher thermal conductivity, the advantage of modified 9 Cr-1 Mo alloy over type 304 stainless steel under thermal fatigue conditions is expected to be even better.

A very important consideration in the use of a given alloy is its design allowable stresses (S_0). For a ferritic steel, S_0 is given as the lowest of the following four stress values at a given temperature:

1. Tensile: one-fourth of the tensile strength at temperature, which is defined as the smaller of (a) the specified minimum tensile strength at room temperature or (b) a value 10% greater than the minimum tensile strength at temperature.
2. Yield: five-eighths of the minimum yield strength at temperature.
3. Rupture: (a) 0.67 of average rupture stress for 100,000 h or (b) 0.8 of minimum rupture stress for 100,000 h.
4. Secondary (or minimum) creep rate: the average secondary creep rate for 0.01% creep per 1000 h (equivalent to 1%/100,000 h).

The estimated allowable stresses based on the criteria listed above are plotted in Fig. 5. This figure includes values for 2 1/4 Cr-1 Mo, standard 9 Cr-1 Mo, and type 304 stainless steel. It shows that modified 9 Cr-1 Mo steel has higher allowables than the other ferritic materials over the entire temperature range from 427 to 704°C. The modified alloy is also estimated to have allowable stresses equal to or greater than those of type 304 stainless steel to about 600°C. For a given design stress, modified 9 Cr-1 Mo alloy can be used about 75°C higher than other ferritics and thus has an excellent chance of replacing type 304 stainless steel.

To gain commercial experience with modified 9 Cr-1 Mo alloy, we have installed tubes in two conventional utility power plants. At a Tennessee Valley Authority power plant the modified tubes replaced

type 321 stainless steel tubes and have operated successfully since May 1980. At a fossil plant of American Electric Power, the modified alloy replaced type 304 stainless steel, and these tubes have been in operation since April 1981.

Work is continuing in the areas of mechanical properties, physical properties, weldability, and thermal aging effects. Initially we expect to obtain approval of modified 9 Cr-1 Mo in Sections I and VIII (for nonnuclear applications) of the ASME Code by 1982 or 1983. The nuclear application of this alloy will require a substantially larger data base and thus ASME Code approval for Section III is not expected until 1985.

SUMMARY

Although chromium is a critical element in many materials applications, over 91% of the chromium used by the United States is imported. To minimize our dependence on foreign sources of supply requires alloys that use less chromium than do present alloys such as stainless steels. This paper has outlined the development of a modified 9 Cr-1 Mo alloy, which uses half of the chromium and a trace amount of nickel compared with stainless steel, but has elevated-temperature properties matching those of type 304 stainless steel up to 600°C. The design allowable stresses of this alloy are factors of 2 to 3 higher than those of other ferritic steels in the temperature range of 500–700°C. For a given design stress, the modified alloy can be used at 75°C higher than other ferritic alloys that have from 2.2 to 12% Cr. Improved elevated-temperature strength along with excellent physical properties of this modified alloy are expected to make it quite resistant to thermal fatigue.

Data on the modified 9 Cr-1 Mo alloy presented in this paper show that there may be many applications where it could replace stainless steel and thereby reduce the need for imported chromium.

REFERENCES

1. F. Warshofsky, "Strategic Minerals the Invisible War," *Reader's Digest*, Feb. 1981, pp. 81-85.
2. R. A. Moen and L. D. Blackburn, Hanford Engineering Development Laboratory, Private Communication, 1974.

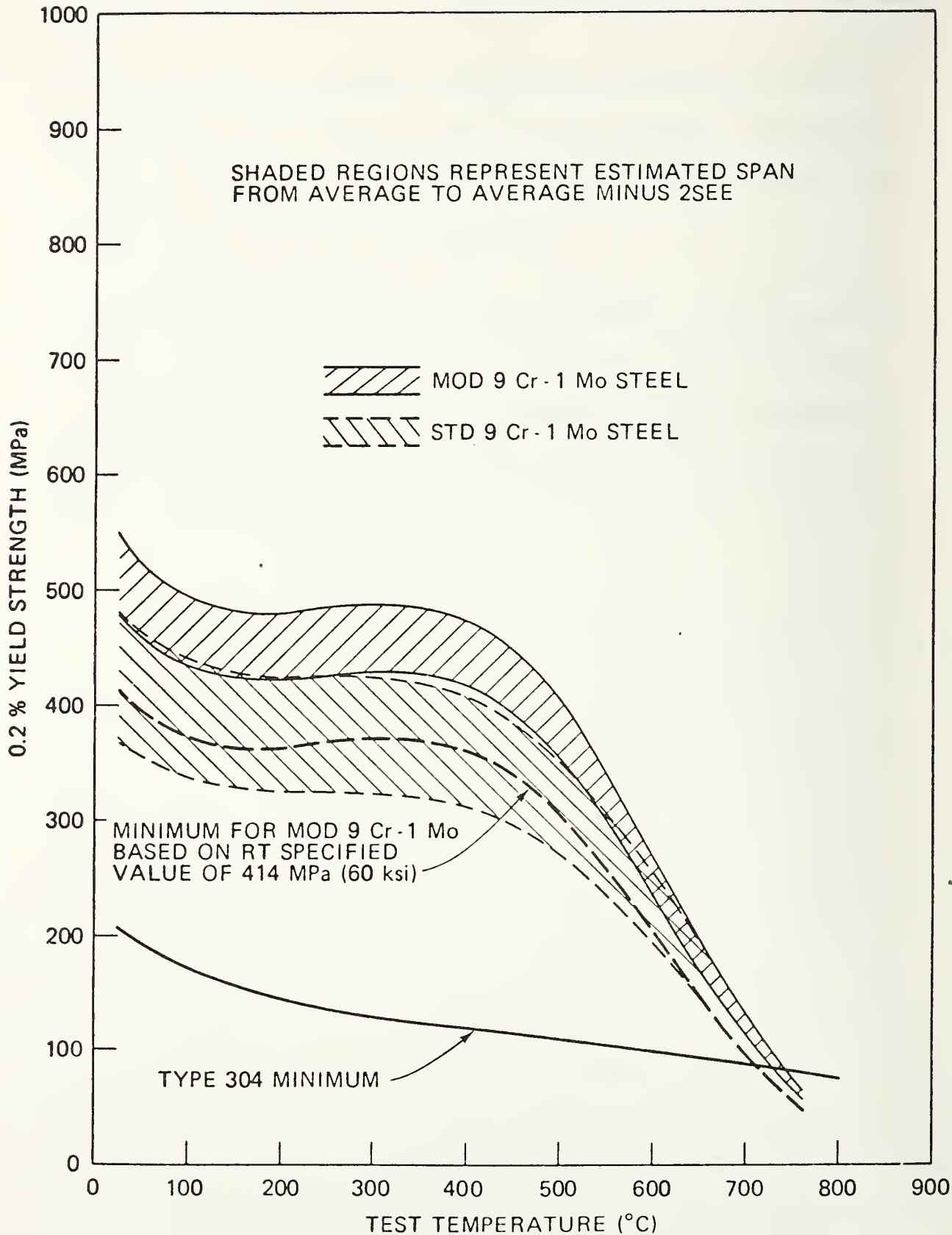

Fig. 1. Comparison of 0.2% yield strength curves for standard and modified 9 Cr-1 Mo and type 304 stainless steel.

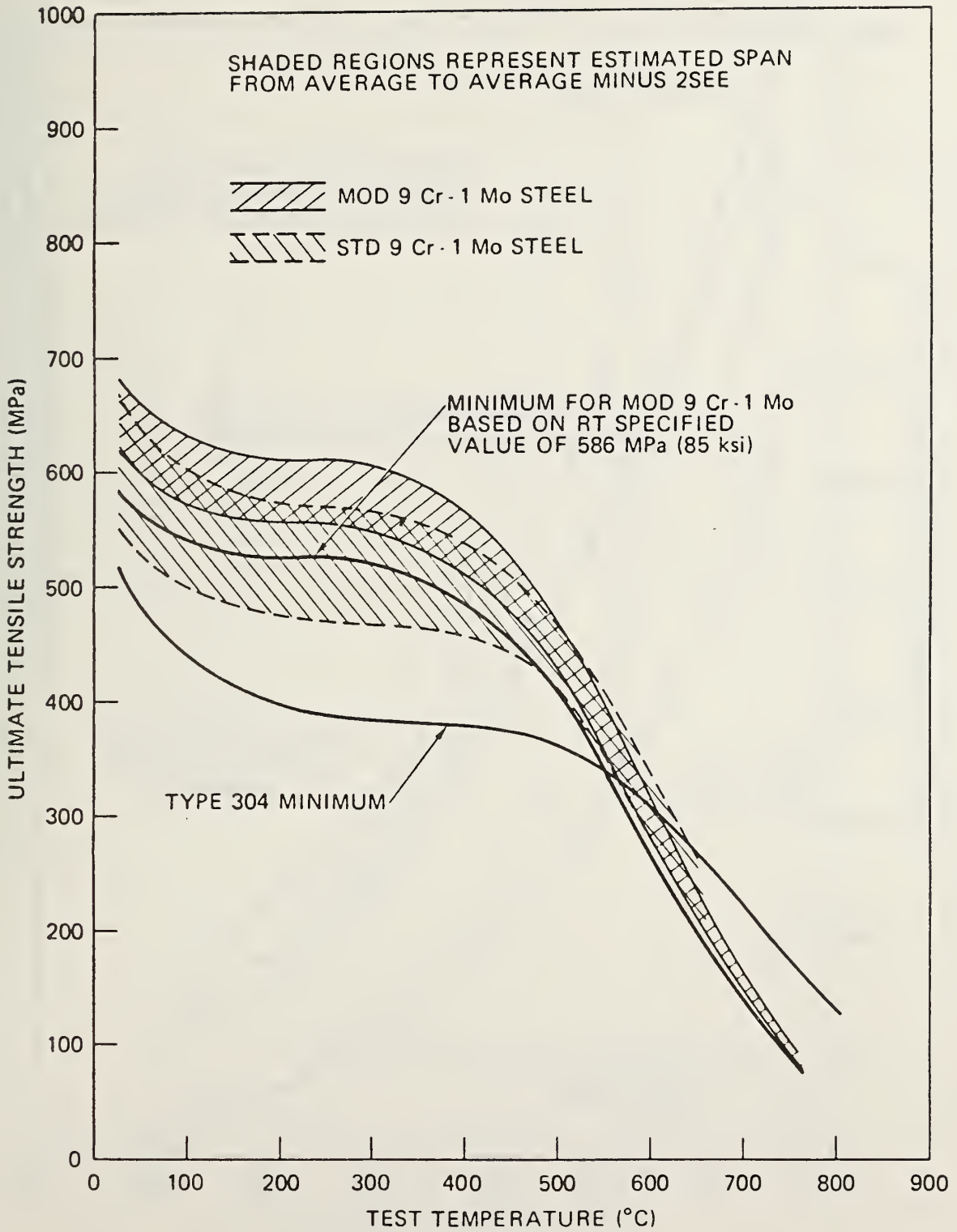

Fig. 2. Comparison of ultimate tensile strength curves for standard and modified 9 Cr-1 Mo and type 304 stainless steel.

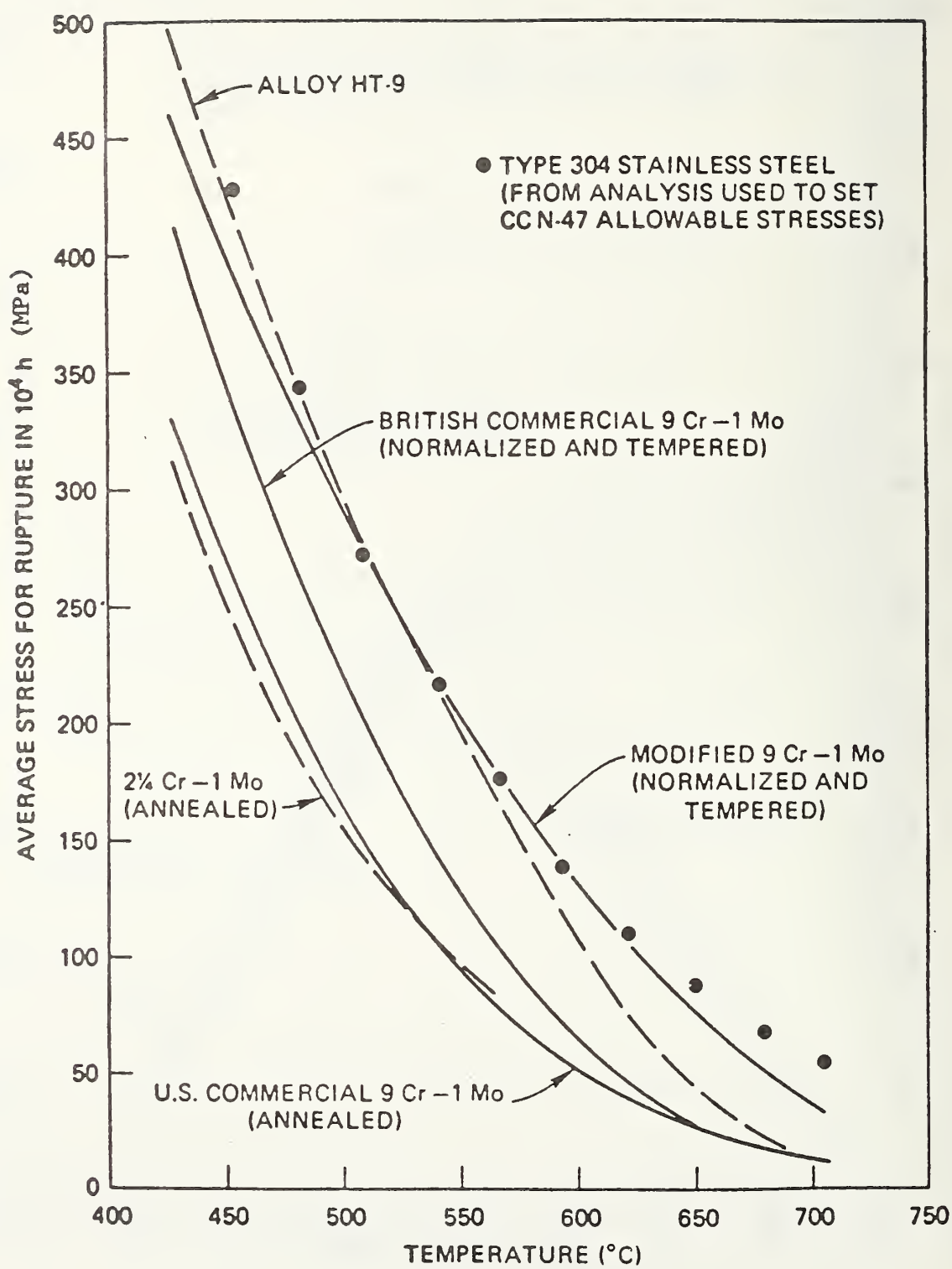

Fig. 3. Variation of 10^4 -h creep-rupture strength with temperature for several materials.

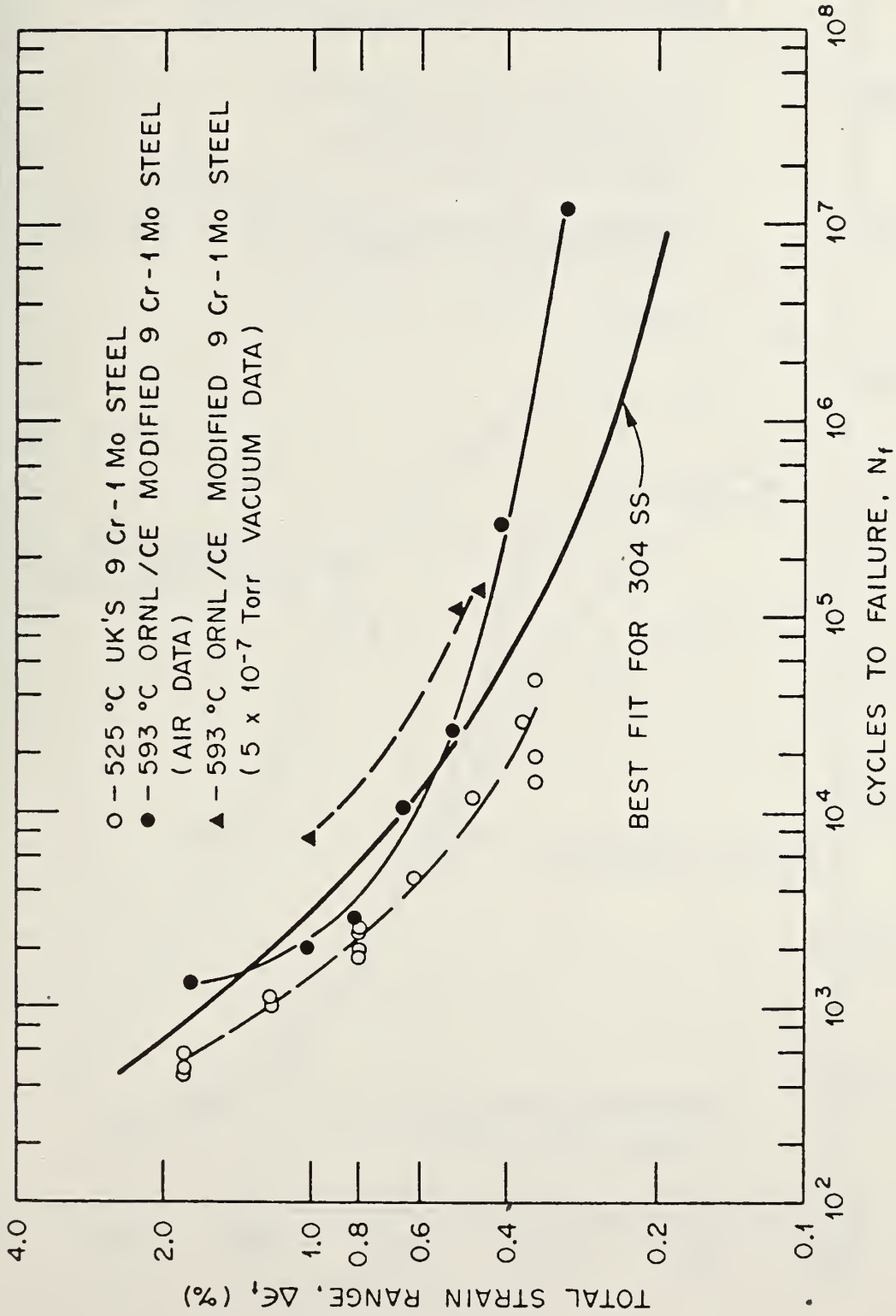

Fig. 4. Comparison of continuous cycling fatigue data on modified 9 Cr-1 Mo steel with standard 9 Cr-1 Mo steel and type 304 stainless steel.

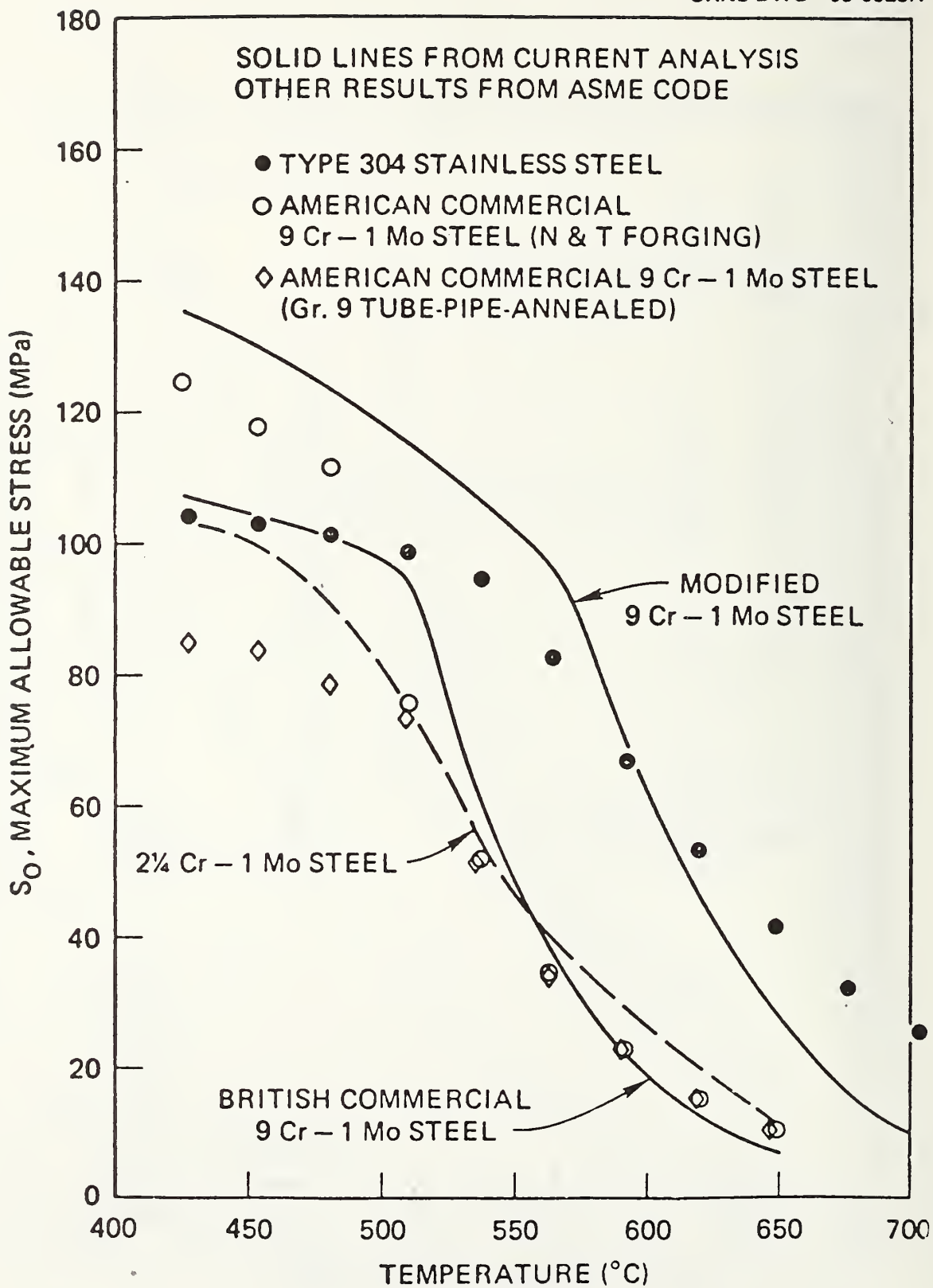

Fig. 5. Variation of estimated design allowable stress intensity, S_0 , with temperature for several materials.

COBALT, A VITAL ELEMENT IN THE AIRCRAFT ENGINE INDUSTRY

Joseph R. Stephens
NASA-Lewis Research Center

CONSERVING COBALT

Cobalt, A Vital Element In The Aircraft Engine Industry

Joseph R. Stephens
NASA Lewis Research Center
Cleveland, OH 44135

Cobalt Session Keynote Paper

for

Department of Commerce's
Workshop on Conservation and Substitution
Technology for Critical Materials
(June 15-17, 1981)

ABSTRACT

Recent trends in the United States consumption of cobalt indicate that superalloys for aircraft engine manufacture require increasing amounts of this strategic element. Superalloys consume a lion's share of total U.S. cobalt usage which was about 16 million pounds in 1980. In excess of 90 percent of the cobalt used in this country was imported, principally from the African countries of Zaire and Zambia. Early studies on the roles of cobalt as an alloying element in high temperature alloys concentrated on the simple Ni-Cr and Nimonic alloy series. The role of cobalt in current complex nickel-base superalloys has not been well defined and indeed, the need for the high concentration of cobalt in widely used nickel-base superalloys has not been firmly established. This paper will review the current cobalt situation as it applies to superalloys and describe briefly the opportunities for research to reduce the consumption of cobalt in the aircraft engine industry--a field of research being addressed by NASA's COSAM (Conservation of Strategic Aerospace Materials) Program.

INTRODUCTION

Periodically the United States metallurgical industry is faced with shortages of strategic materials that are critical to the economical health of our country. In the early 1970's the potential reduction of chromium supply, brought about in part by U.S. government sanctions against Rhodesia (now

Zimbabwe), led to a number of studies¹, workshops², and research efforts^{3,4}. NASA Lewis Research Center's research efforts focused on reducing chromium in 304 stainless steel which constitutes the largest single use of chromium in this country. Results indicated that substituting aluminum and molybdenum for a portion of the chromium produced an austenitic alloy with comparable properties to that of 304 stainless steel and with the potential of conserving one-third the chromium in this alloy³.

In the late 1970's another strategic metal shortage occurred in this country which had a major impact on superalloy producers. Because of political instabilities in Zaire, cobalt supply to the United States was disrupted. Producer cobalt supply to alloy melters in 1978 and 1979 was put on an allotment of 70 percent of 1977 usage. In addition to these disruptions, a titanium sponge shortage plagued U.S. alloy producers in the late 1970's.

Recent developments indicate that official policies of the United States are now taking materials shortages seriously. The National Materials Policy Act⁵ was passed into law during 1980. This Substitution Workshop, sponsored by the Department of Commerce, is in direct response to this Act and a report of this Workshop and other activities will be delivered to the Congress by the Department of Commerce later this year. It is interesting to note that the Department of Commerce chose the aerospace industry as its case study of strategic materials. We at NASA Lewis Research Center have formulated the COSAM (Conservation of Strategic Aerospace Materials) Program⁶ with special interest on the four strategic elements cobalt, columbium, tantalum, and

chromium. Initial research efforts, underway since early 1980, are concentrated on determining the role of cobalt in superalloys. Superalloys constitute the single largest U. S. usage of cobalt. Therefore, the papers presented in this two-part session on cobalt are very timely and of extreme interest to the United States economy. An indication of the importance placed on cobalt by the current administration is the recent announcement that \$100 million would be used to build-up the U. S. stockpile⁷. Cobalt was singled out as the first commodity to be purchased under this plan.

This paper will present the cobalt situation in the U.S. as it exists now, describe the role of cobalt in nickel-base alloys, and describe the initial COSAM Program on cobalt which was undertaken in 1980.

GEOGRAPHICAL CONSIDERATIONS

In planning and establishing our COSAM Program, strategic materials were defined as those predominantly or wholly imported elements contained in the metallic alloys used in aerospace components which are essential to the strategic economical health of the U.S. aerospace industry. Cobalt was identified as being within this definition of a strategic material. The United States imports over 90 percent of the annual consumption of cobalt. Figure 1 shows the leading producers of cobalt. The African countries of Zaire and Zambia are noted to be the leading cobalt producers. Also listed in figure 1 are the sources of U.S. imported cobalt in 1980⁸. Zaire and Zambia supply over 70 percent of the U.S. imports. This producer and supplier

situation places the United States in an extremely vulnerable position if supplies are cutoff for any length of time. An example of this occurred in 1978 and 1979 because of the political disruptions that Zaire experienced in those years.

The objective of the COSAM Program is to provide technology options which will support the aerospace industry in making strategic economic decisions aimed at significantly reducing strategic metal (such as cobalt) consumption. This Workshop along with other activities will help focus attention on our non-fuel strategic material situation.

ECONOMICAL CONSIDERATIONS

Most of you are aware of the price increase in cobalt that has taken place since 1977. Cobalt metal that was selling at around \$5.50 per pound in 1977 increased to over \$30.00 per pound during 1979 with spot prices as high as \$55.00 per pound. A historical rule-of-thumb has been that the price of cobalt is typically higher than that of nickel by a factor of two to three times. In 1980 that factor was in excess of seven times.

It is interesting to compare the price increase in cobalt with that of oil, a commodity that most of us are concerned with. The average prices for the year 1972 were chosen as a basis of comparison since this was just before oil prices skyrocketed. The price of cobalt was \$2.45⁹ per pound while OPEC oil sold for \$2.28 per barrel¹⁰. Figure 2 shows that OPEC oil experienced a rapid rise in price during 1974 and again in 1979 and 1980. Interestingly enough, cobalt price increase has kept pace with that of oil over the past

eight years. Just as oil price increases have influenced the use pattern of this commodity, the price of cobalt has brought about changes the use pattern of this commodity as well. Some of the trends in cobalt usage will be discussed in a latter section of this paper.

Even though the changes in prices of oil and cobalt have been similar over the last eight years, the response by the American public and press has been quite different. There has been a strong demand for conservation of and substitution for oil, but the cobalt situation has received only minor attention. The reason is the difference between the place of oil and cobalt in the economy. A cutoff of oil for a few months could severely cripple our economy particularly in the area of transportation and home heating. In contrast the average consumer would not even know a cutoff of cobalt had occurred unless it extended for a prolonged length of time.

A second reason is the tremendous demand for oil in this country compared to most any other commodity. Annual consumption of oil is compared to that of cobalt in figure 3 along with two other mineral commodities. Oil¹¹ is consumed by a factor of over five orders of magnitude compared to cobalt⁸. Iron ore, the largest used nonfuel mineral commodity, is overshadowed by oil consumption. With the volume of oil imported (over one-half of consumption) a significant effect on the balance-of-payments exists with a slight increase in price. In contrast, with the relative small amount of cobalt imported (even though over 90 percent is imported), a price increase comparable to that of oil has a negligible effect on the balance-of-payments. These factors suggest that the concentrated users of cobalt must take the lead in identifying effective substitutes for cobalt that will permit the United States to remain competitive in the world market.

USAGE CONSIDERATIONS

Primarily because of the spiraling cost of cobalt, the United States has experienced a decline in cobalt usage since 1978. Figure 4 shows that 20 million pounds of cobalt were consumed in 1978 and that in 1980 usage was down to 16 million pounds, a 20 percent reduction in usage in only 2 years. During this same time period the use of cobalt to produce superalloys, primarily for aircraft engines, increased from 4 million pounds in 1978 to 7.2 million pounds in 1980. This change represents an 80 percent increase in cobalt usage in superalloys in only two years. The numbers are from the Department of Interior's Mineral Industry Surveys¹².

The importance of cobalt to superalloy production is illustrated in figure 5. It should be noted that 45 percent of the 16 million pounds of cobalt consumed by the United States in 1980 went for superalloy production. So even though total U.S. usage is down, superalloy usage continues to grow. The shift away from cobalt usage has been achieved primarily by the magnetic materials industry and by the manufacturers of tool bits and dies. This has been accomplished by utilizing ferrite magnets and development of cobalt-free cutting tools.

The increased usage of cobalt in superalloys can be attributed largely to the increased orders of aircraft engines which is the predominate superalloy market. Airlines have announced orders for new planes to supplement their current fleets, and the new engines will require large amounts of the strategic metal cobalt. Since the aircraft industry is a major factor on the

positive side of the U.S. balance-of-payments,¹³ a healthy aircraft industry is of utmost importance to the United States. Because of this, the NASA COSAM Program, industry efforts, and other activities underway are essential to assure that if the cobalt supply is disrupted, viable substitutes and alternatives are available to aircraft engine designers and producers.

METALLURGICAL CONSIDERATIONS

Cobalt is used in a variety of both cobalt-base and nickel-base superalloys. The largest usage in terms of pounds consumed, however, is in nickel-base alloys. Several nickel-base and cobalt-base superalloys are listed in figure 6 which shows the range of cobalt content in these alloys. Figure 6 also shows that cobalt is found in cast, wrought, and powder metallurgy alloys. One of the largest consumers of cobalt is Waspaloy, a wrought alloy used in aircraft engine turbine and compressor disks. These components are heavy (thus consuming significant quantities of cobalt) but are vital to today's high-temperature aircraft turbine engines.

In a recent publication by Tien, et al.,¹⁴ a review of the existing literature on the role of cobalt in superalloys was presented. In addition an empirical model of the role of cobalt in superalloys was discussed at some length. A summary of the various roles of cobalt on mechanical and physical properties of superalloys observed by a number of investigators is presented in figure 7. Based on a high-temperature torsion test, cobalt additions in the advanced Nimonic series of alloys was reported to improve hot-workability.

Figure 8, from the paper by Heslop¹⁵ (test temperature not stated), illustrates that there is a linear dependence of the number of twists to failure and the cobalt content of the Nimonic alloy.

Cobalt has been reported by Habraken and Coutsouradis¹⁶ to improve oxidation/corrosion resistance of high temperature alloys. This conclusion was based in part on the work on simple composition cobalt-chromium binary alloys compared to similar composition iron or nickel-base alloys.

The primary role of cobalt in nickel-base superalloys of interest to aircraft engine producers is its beneficial effect on high-temperature strength properties. Figure 7 shows that cobalt's beneficial effect on stress-rupture strength has been noted by Urbain¹⁷ for Nimonic and Inconel alloys. More recently similar results have been noted by Maurer¹⁸ (Waspaloy), Nathal¹⁹ (MAR-M247), and Tien²⁰ (Udimet 700) where cobalt was systematically removed in incremental steps from these three complex composition superalloys. The latter two research efforts are part of the NASA COSAM Program and will be presented during this Cobalt Session of the Workshop.

A summary of Urbain's observations is presented in figure 9. Stress-rupture strength against temperature is shown for Nimonic 80A and Nimonic 90 (an alloy of similar composition to that of Nimonic 80A but with 17 percent cobalt added). An improvement in stress-rupture strength of these wrought alloys is noted as a result of the cobalt addition. A similar effect is noted in figure 9 for the cast alloys Inconel 713C (no cobalt) and Inconel 717C (similar composition, but with 8 percent cobalt added).

Creep curves for reduced cobalt Waspaloy-type alloys, based on the work of Maurer, are shown in figure 10. It should be noted that cobalt increases rupture life, decreases minimum creep rate, and (negatively) reduces creep ductility in Waspaloy at 730⁰C.

The effect of cobalt on microstructure of nickel-base superalloys is summarized in figure 11. It should be noted that most of this research has been reported by Heslop on simple composition nickel-chromium-cobalt (60:20:20) ternary alloys. With the exception of the work by Lund²¹, et al., very little work has been reported on complex composition superalloys. For example, stacking faults were observed in the nickel-chromium-cobalt alloys, while for a binary Ni-Cr alloy (80:20) stacking faults were not observed. This lead to the conclusion that cobalt reduces the stacking fault energy in nickel-base alloys. The effect of cobalt on aluminum and titanium solubility in the nickel-chromium-cobalt system is shown in figure 12. The microstructural influences of cobalt listed in figure 11 are interrelated to the changes in mechanical and physical properties of the nickel-base superalloys. However, the specifics of this interrelationship have not been elucidated at this point in time.

SUPERALLOY FUNDAMENTAL RESEARCH

As was brought out in the preceding section of this paper, much of the research aimed at determining the role of cobalt in nickel-base superalloys

has been conducted on simple binary and ternary alloys. As part of the NASA COSAM Program, the determination of the role of cobalt in today's more complex nickel-base superalloys has been undertaken.

Five (four nickel-base and one cobalt-base) superalloys have been selected for the COSAM investigation. The five alloys are listed in figure 13 along with their typical applications in the aircraft engine industry, the forms in which the alloys are used, and remarks as to why they were selected for the COSAM activity. Applications include turbine disks, turbine blades, and combustors. A variety of product forms are represented by the applications of the five alloys, as noted in figure 13. The selection of the five alloys was based primarily upon the considerations given in this figure. Waspaloy^{*} was selected because it represents the highest tonnage of cobalt in commercial aircraft engines. Selection of Udimet-700^{*} was based on the fact that this alloy is used in the as-cast, as-wrought ingot, as-wrought powder, and as-HIP powder-metallurgy fabricated conditions. The potential for determining the impact of cobalt on both conventionally-cast as well as on single crystal turbine blades was the reason for selecting MAR-M247^{*}. Rene' 150^{*} was chosen because it is one of the most advanced directionally-solidified turbine blade alloys. The wrought, sheet alloy HA-188^{*} was selected because it represents one of the largest uses of a cobalt-base alloy in aircraft engines.

*Trademarks

Waspaloy	United Technologies Corporation
Udimet	Special Metals Corporation
MAR-M	Martin Marietta Corporation
Rene'	General Electric Corporation
HA	Cabot Corporation

The primary purpose of the cobalt strategic element substitution research is to determine the fundamental role of cobalt in a wide variety of nickel-base superalloys and in a high-use cobalt-base superalloy. A secondary purpose is to develop the methodology to explore the roles of other strategic elements in similarly chosen alloys so as to have maximum impact on a wide range of users.

Figure 14 shows the current participants in the COSAM activities on cobalt strategic element substitution. These initial research efforts are planned for a three-year period and consist of cooperative programs involving universities, industry, and NASA Lewis Research Center. Nominal compositions of the five alloys given in figure 14 indicate that cobalt content ranges from 10 percent in MAR-M247 to 39 percent in HA-188. In addition the γ' phase ranges from 20 percent in Waspaloy to 65 percent in Rene' 150. The first phase in each research effort will involve substituting the less-strategic-element nickel for cobalt in incremental steps to a zero cobalt content. The effects of this substitution on properties and phases present, such as γ' , will make-up the major portion of the research effort in the first year of each program element. Efforts in subsequent years will be directed at identifying and optimizing alloying elements as substitutes for cobalt in the five alloys so as to maintain the key properties of these alloys.

The cooperative nature (government-industry-academia) of the research being conducted on Waspaloy and Udimet-700 is illustrated in figure 15. The role of industry, as represented by Special Metals Corporation, is outlined. Their primary role is to characterize and optimize fabrication and heat

treating procedures for the reduced cobalt Waspaloy and Udimet-700 alloys. The university role in this effort is also shown in figure 15. Columbia University will be involved with mechanical property characterization, structural stability, microstructural features, and theoretical formulations to identify future alloy modifications if required for the second phase of the project. Purdue University will be primarily responsible for microstructural and microchemistry characterization of the reduced cobalt content alloys. To round out the program, NASA Lewis Research Center will be involved in further mechanical and physical metallurgy characterization of the alloys as shown in figure 15. The output of this cooperative effort is expected to be a clearer understanding of the role of cobalt in nickel-base superalloys to help point the directions for future development of new/modified superalloys.

The research efforts on MAR-M247 and Rene' 150 parallel the previously described efforts on Waspaloy and Udimet-700. It is anticipated that these projects will lead to an understanding of the fundamental role of cobalt in a variety of conventional and directional nickel-base superalloys. These results should provide an improved technical base to guide the identification of high potential modified superalloys in the planned COSAM Program.

CONCLUDING REMARKS

From the literature survey of the information on world cobalt producers and the United States dependence on imports for over 90 percent of the cobalt consumed in this country, it is clear that cobalt is truly a strategic metal. Furthermore, the increase in the use of cobalt for superalloys, which are used

primarily for aircraft gas turbine engines, indicates the vital nature of cobalt to this industry. Of particular concern is the impact that would result to the aerospace industry if cobalt supplies were cut off for an extended length of time.

A review of the literature indicates that the role of cobalt in nickel-base superalloys is not clearly defined and the minimum amount required has not been established. These factors give rise to the need for research to determine the roles of cobalt in superalloys and to identify effective alloying substitutes for cobalt. From these basic research studies, alloys may be identified that minimize or eliminate the need for cobalt in nickel-base superalloys, thus providing non-strategic element alternatives to aircraft engine producers in the event of a cobalt crisis. The initial efforts now underway in the NASA COSAM Program should help meet this national need.

REFERENCES

1. "Contingency Plans for Chromium Utilization", NMAB-335, National Materials Advisory Board, National Academy of Sciences, Washington, D. C., 1978.
2. "Summary Report on Air Force Chromium Workshop", (AD-B015411L) Air Force Materials Lab, Wright-Patterson AFB, OH, Dec. 17, 1974.
3. Stephens, J. R.; Barrett, C. A.; and Chen, W. Y. C.: "Corrosion/Oxidation Behavior of Stainless Steels of Reduced Chromium Content", Reviews on Coatings and Corrosion, Vol. 3, No. 4, 1979, pp. 211-252.
4. Dunning, J. S.: "Iron-Based Alloys Strengthened by Ternary Laves Phases", Bureau of Mines, RI 8411, 1980.
5. "National Materials and Minerals Policy, Research and Development Act of 1980", Public Law No. 96-479.
6. Stephens, J. R.: "NASA's Activities in the Conservation of Strategic Aerospace Materials", NASA TM 81617, Presented at 1980 Fall Meeting of the American Society for Metals, Cleveland, OH, October, 1980.
7. "GSA Seeks Cobalt Proposals", American Metal Market/Metalworking News, April, 1981.
8. "Mineral Commodity Summaries", 1981, Bureau of Mines, Department of the Interior, Washington, D. C., 1981.
9. "Cobalt, Mineral Commodity Profiles", Bureau of Mines, Department of the Interior, Washington, D. C., October 1979.
10. "Weekly Petroleum Status Report", DOE/EIA-0208(81/18), Energy Information Administration, Department of Energy, May, 1981.

11. Netschert, B. C.: "U.S. Dependence on Imported Non fuel Minerals: The Threat of Mini-OPECs?", *Journal of Metals*, March, 1981, pp. 31-38.
12. "Mineral Industry Surveys, Cobalt in 1978, 1979, and 1980", Bureau of Mines, Department of Interior, Washington, D. C.
13. "Aerospace Review and Forecast 1979/80", *Aerospace*, Vol. 18, No. 1, Winter, 1980, p. 4.
14. Tien, J. K.; Howson, T. E.; Chen, G. L.; and Xie, X. S.: "Cobalt Availability and Superalloys", *Journal of Metals*, October 1980, pp. 12-20.
15. Heslop, J.: "Wrought Nickel-Chromium Heat-Resisting Alloys Containing Cobalt", *Cobalt*, No. 24, September 1964, pp. 128-137.
16. Habraken, L.; and Coutsouraclis, D.: "Tentative Synthesis on the Role of Cobalt in High-Strength Alloys", *Cobalt*, No. 26, March 1965, pp. 10-24.
17. Urbain, M.: "Cobalt in Steels and Alloys", *Cobalt*, No. 12, September 1961, pp. 11-24.
18. Maurer, G. E.; Jackman, L. A.; and Domingue, J. A.: "Role of Cobalt in Waspaloy", *Superalloys 1980*, J. K. Tien, ed., ASM, Metals Park, OH, 1980, pp. 43-52.
19. Nathal, M.: "The Role of Cobalt in a Nickel Base Superalloy", Presented at the AIME Annual Meeting, February 22, 1981, Chicago, IL.
20. Tien, J. K.: "Role of Cobalt in Astroloy", *Workshop on Conservation and Substitution Technology for Critical Materials*, June 15, 1981, Nashville, TN.

21. Lund, C. H.; Woulds, M. J.; and Hockin, J.: "Cobalt and Sigma - Participant, Spectator or Referee?", International Symposium on Structural Stability in Superalloys, Seven Springs, PA, 1968, pp. 25-46.

FIGURE 1

LEADING COBALT PRODUCERS
(MILLION POUNDS)

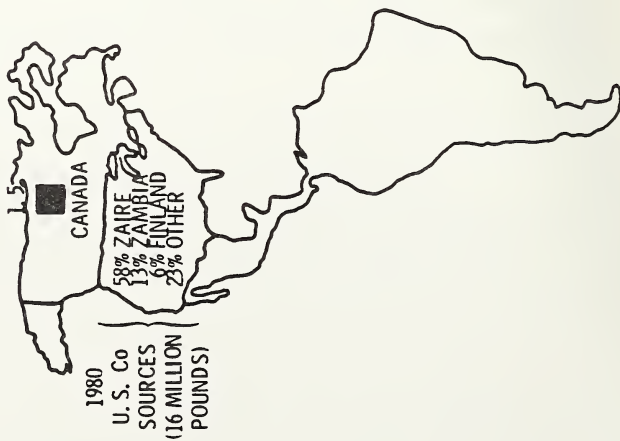
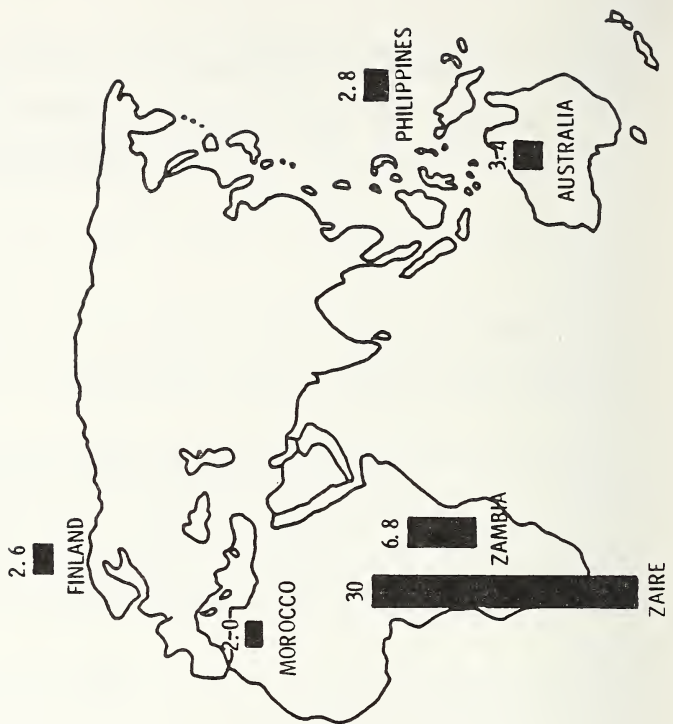

FIGURE 2

PRICE TREND COMPARISON OF COBALT AND OPEC OIL 1972-1980

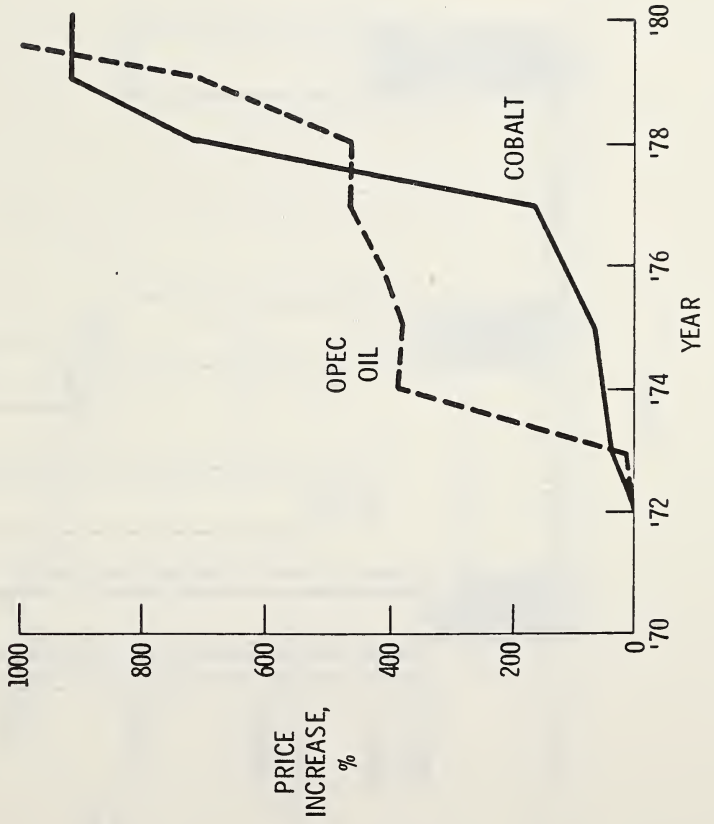

FIGURE 3

1980 UNITED STATES CONSUMPTION OF SELECTED COMMODITIES

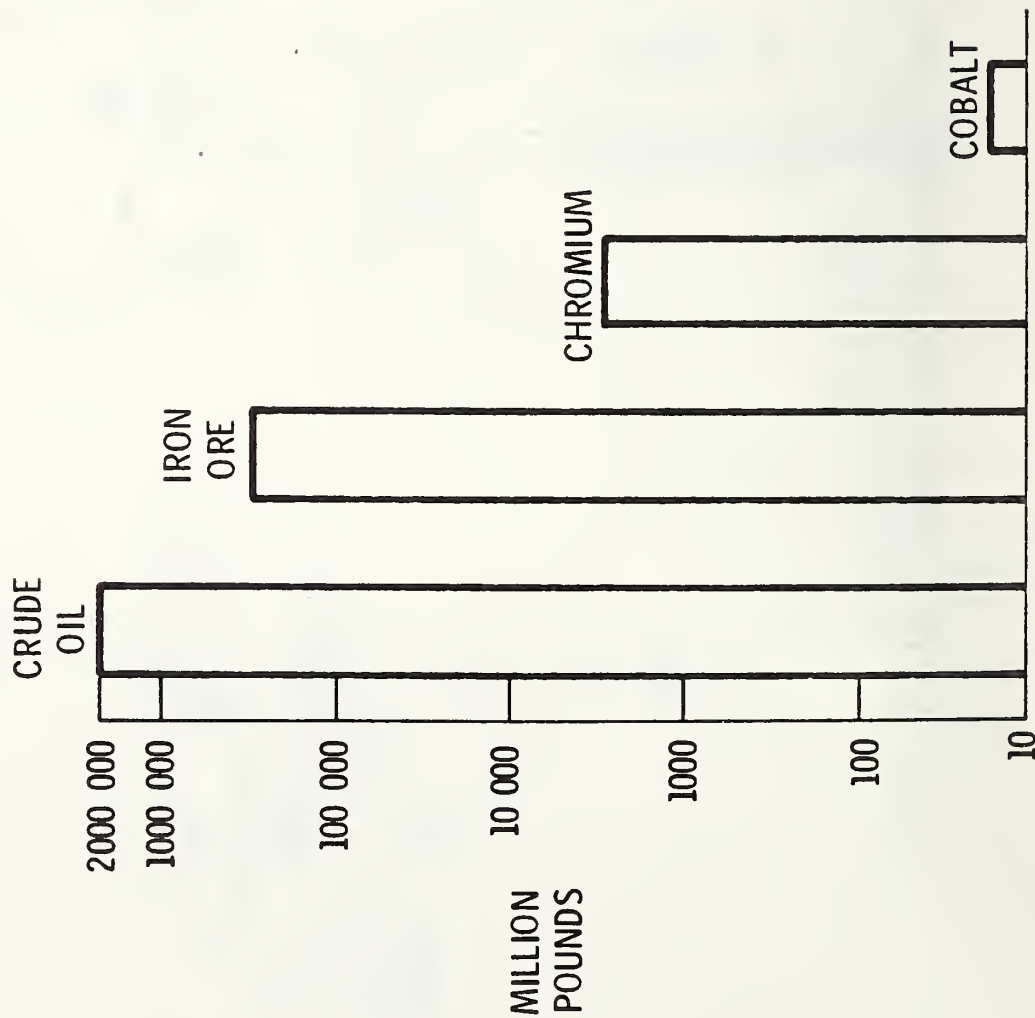

FIGURE 4

RECENT TRENDS IN U.S. AND AEROSPACE COBALT USAGE

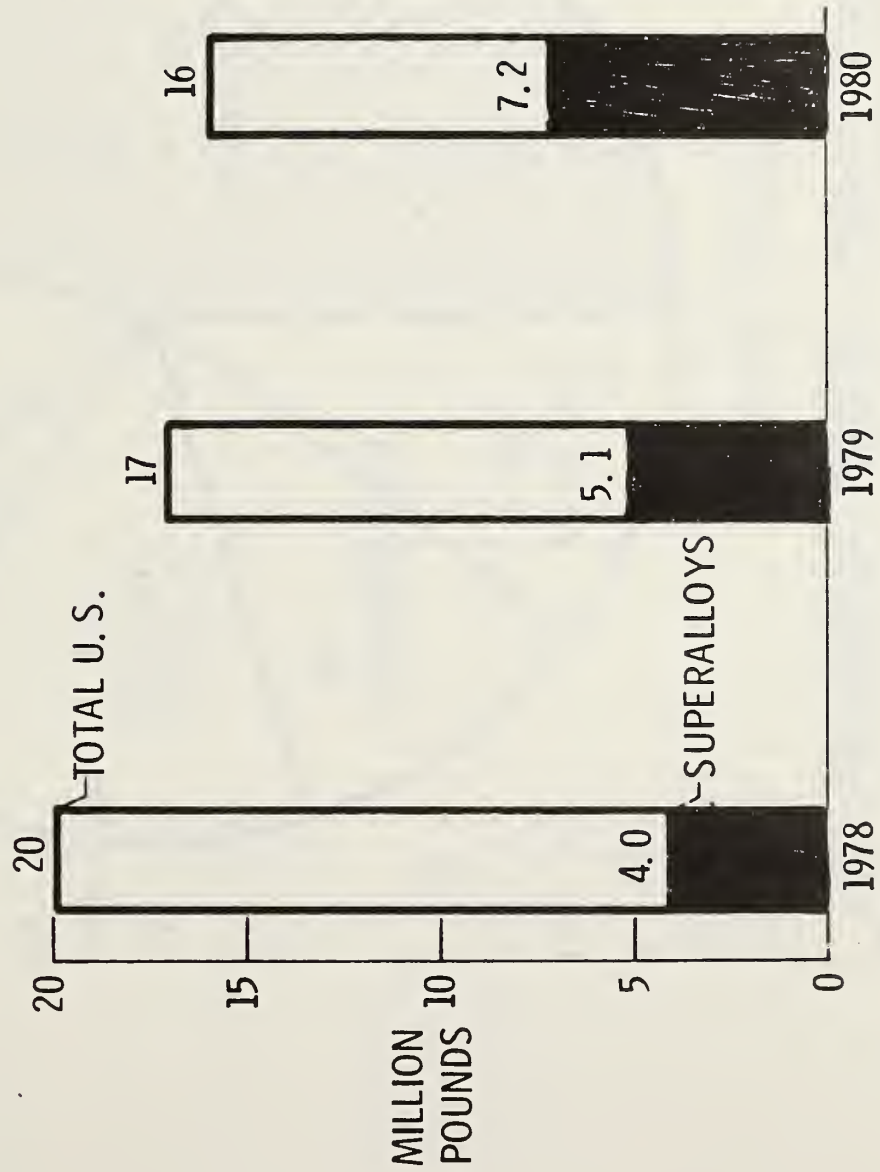

FIGURE 5

DISTRIBUTION OF 1980 U.S. COBALT CONSUMPTION

(16 MILLION POUNDS)

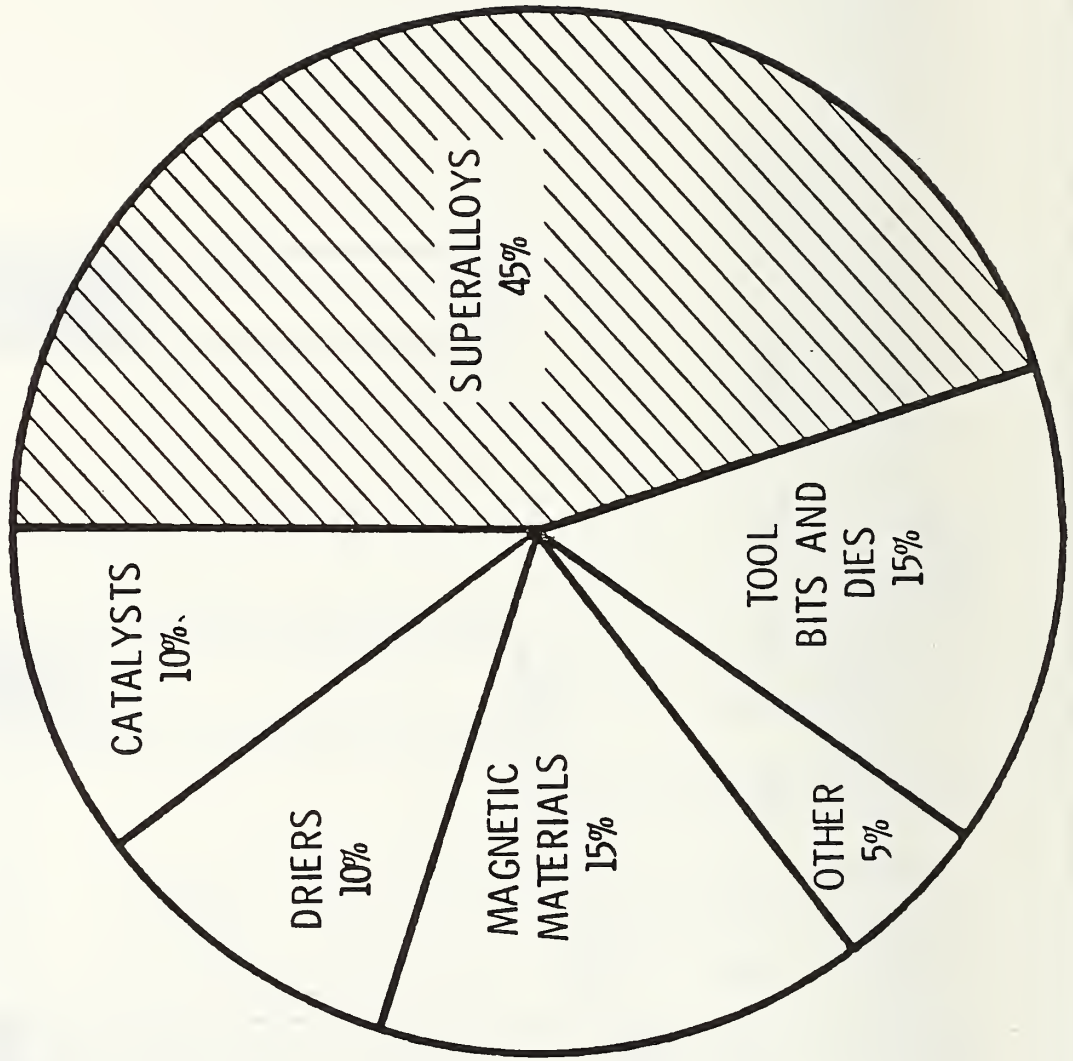

FIGURE 6

COBALT CONTENT OF TYPICAL SUPERALLOYS

<u>ALLOY DESIGNATION</u>	<u>CAST</u>	<u>% COBALT NOMINAL</u>
HS - 31		55
MAR-M509		55
IN - 100		15
B - 1900		10
IN - 738		8
	<u>WROUGHT</u>	
L - 605		55
S - 816		45
HA - 188		39
U - 700		19
WASPALLOY		14
MAR-M247		10
	<u>POWDER METALLURGY</u>	
1056		19
U - 700		19
R - 95		8

FIGURE 7

COBALT'S ROLE IN SUPERALLOYS
MECHANICAL/PHYSICAL PROPERTIES

<u>COBALT</u>	<u>ALLOY SYSTEM</u>	<u>AUTHOR</u>
<u>APPARENT EFFECT</u>		
IMPROVES HOT WORKABILITY	NIMONIC SERIES	HESLOP
INCREASE OXIDATION/CORROSION RESISTANCE	COBALT - BASE	HABRAKEN & COUTSOURADIS
INCREASE STRESS-RUPTURE LIFE	NIMONIC SERIES INCONEL SERIES WASPALLOY MAR-M247 UDIMET 700	URBAIN URBAIN MAURER NATHAL TIEN

FIGURE 8

COBALT EFFECT ON HOT-WORKABILITY (ADVANCED NIMONIC ALLOY)

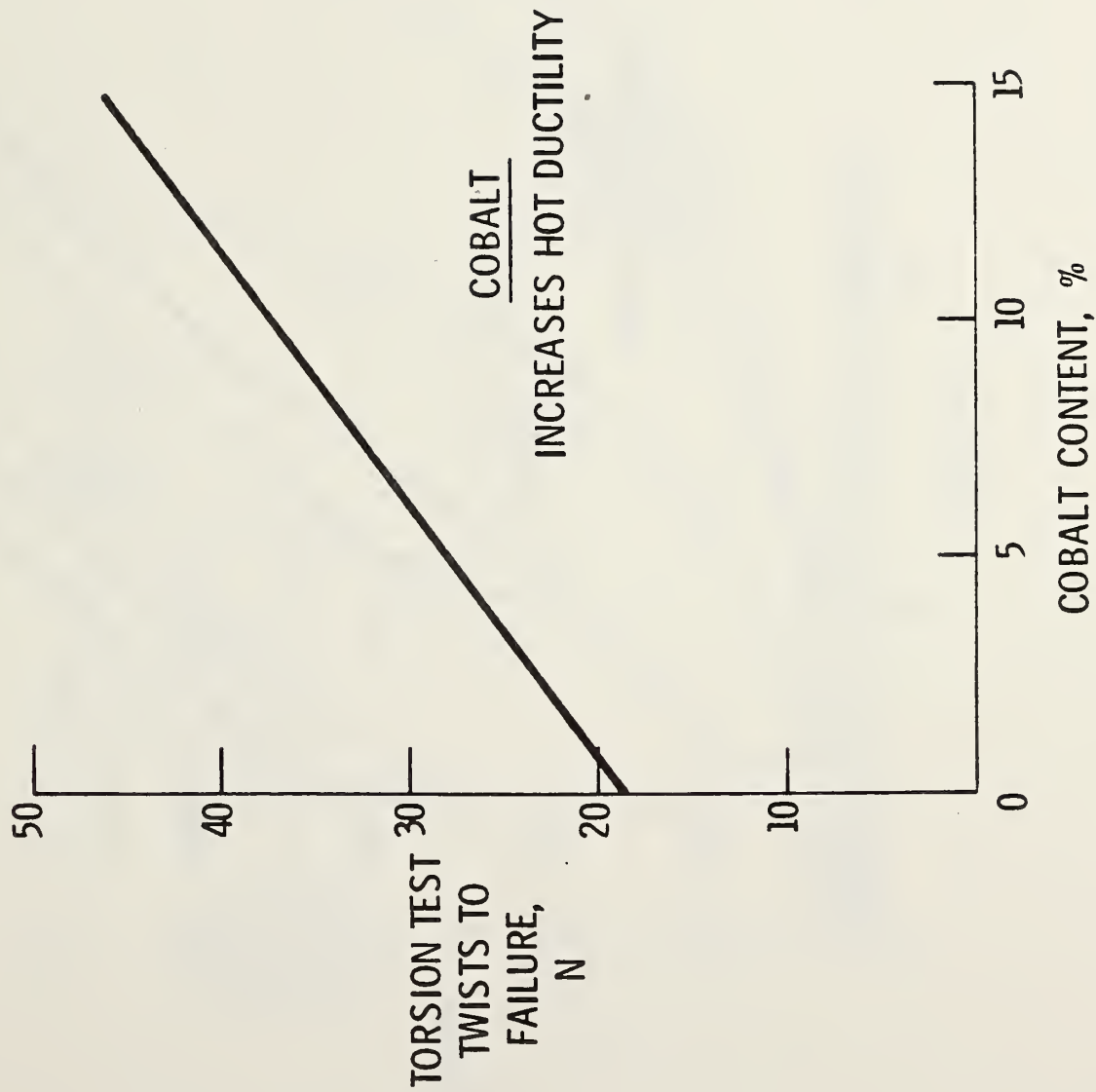

FIGURE 9

COBALT EFFECT ON RUPTURE STRENGTH

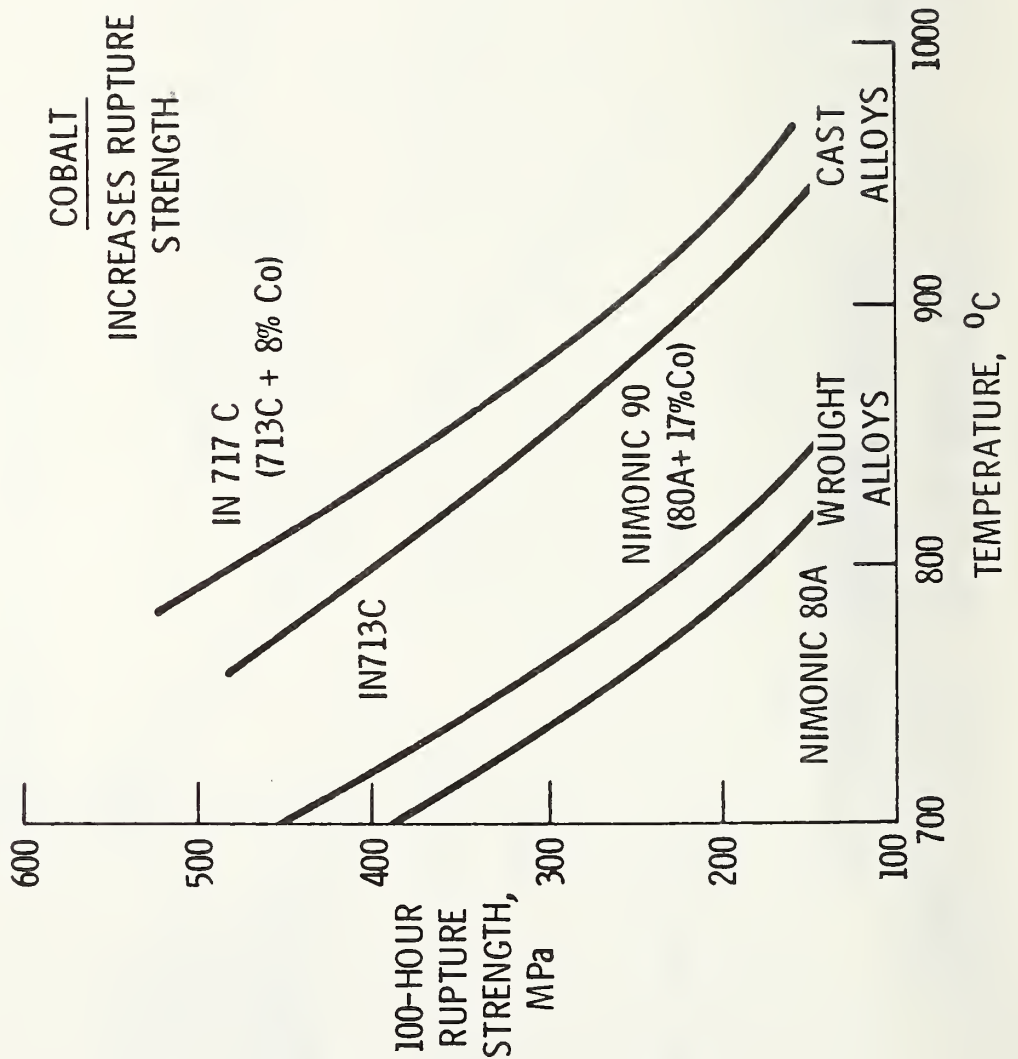
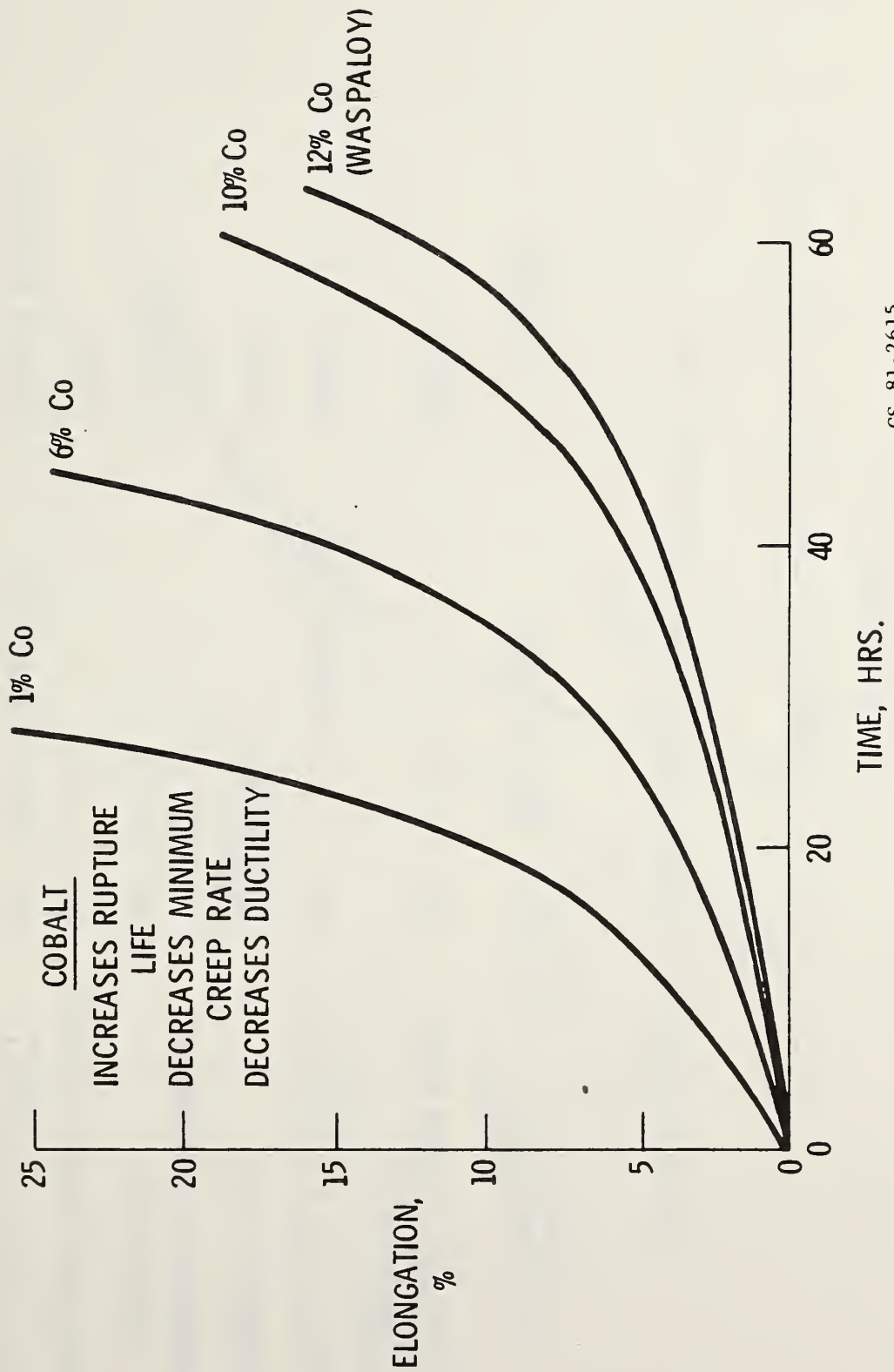

FIGURE 10

COBALT'S EFFECT ON CREEP OF WASPALOY

730°C - 550 MPa



CS-81-2615

FIGURE 11

COBALT'S ROLE IN SUPERALLOYS MICROSTRUCTURE

<u>COBALT APPARENT EFFECT</u>	<u>ALLOY SYSTEM</u>	<u>AUTHOR</u>
DECREASE STACKING FAULT ENERGY	Ni - Cr - Co	HESLOP
REDUCE Al & Ti SOLUBILITY	Ni - Cr - Co, NIMONIC SERIES	HESLOP
INCREASE γ' v/o	Ni - Cr - Co	HESLOP
INCREASE γ' SOLUTIONING TEMPERATURE	Ni - Cr - Co	HESLOP
INCREASE CARBON SOLUBILITY	Ni - Cr - Co	HESLOP
SUBSTITUTE FOR Ni IN $M_{6}C$	Ni - BASE SUPERALLOYS	SABAL & STICKLER
INCREASE ALLOY STABILITY (σ)	MAR - M421	LUND, ET.AL.

FIGURE 12

COBALT EFFECT ON TITANIUM-ALUMINUM SOLUBILITY

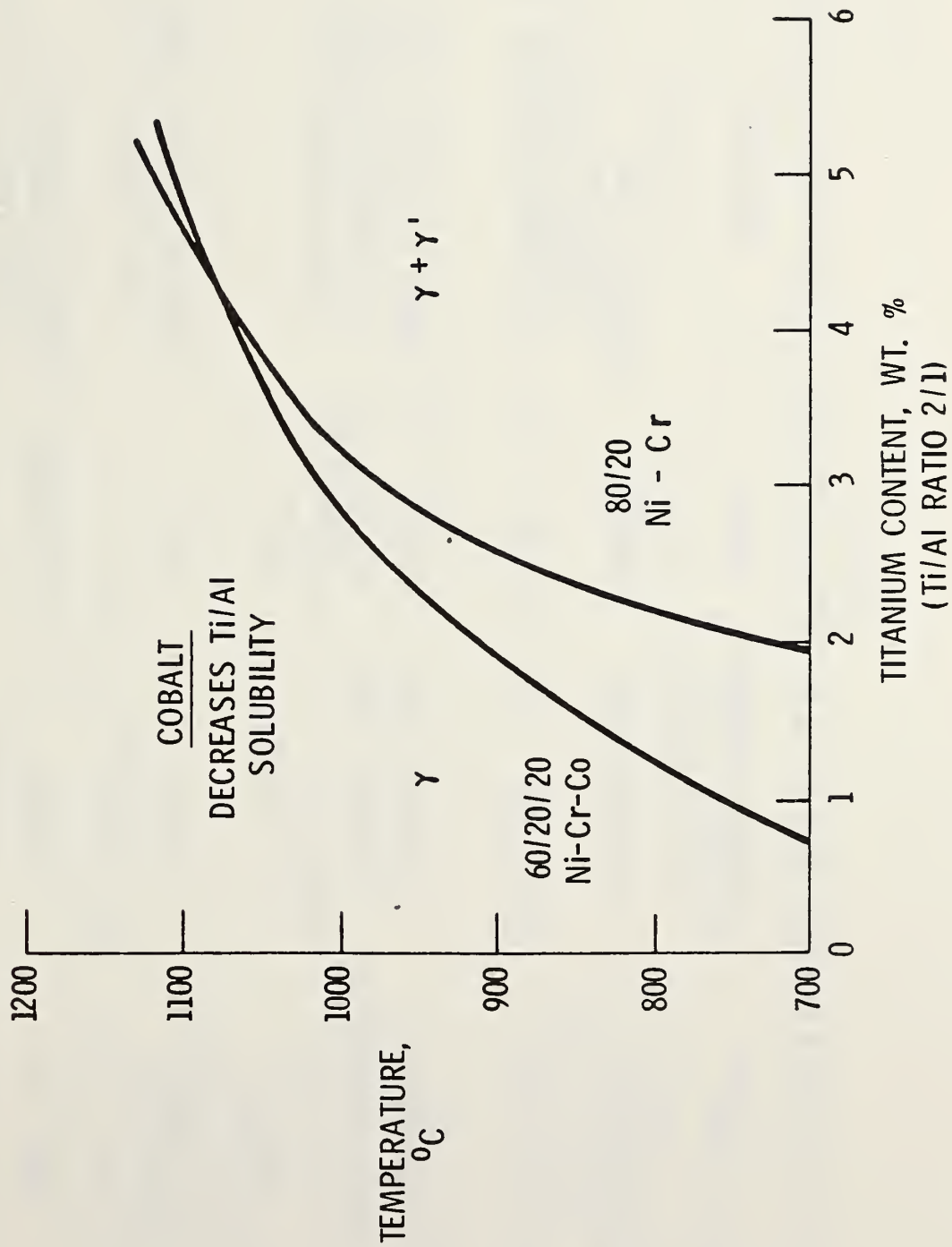

FIGURE 13
 SUPERALLOYS SELECTED FOR INITIAL COSAM ACTIVITIES

ALLOY	TYPICAL ENGINE APPLICATION	FORM	REMARKS	
WASPALLOY	TURBINE DISK	FORGED	HIGHEST USE WROUGHT ALLOY IN CURRENT ENGINES	
UDIMET-700 (LC) ASTROLOY (RENÉ 77)	TURBINE DISK TURBINE DISK LP BLADES	FORGED AS-HIP- POWDER CAST	SIMILAR ALLOYS USED IN VARIOUS FORMS AND APPLICATIONS	
MAR-M247	TURBINE BLADES	CAST		CONVENTIONALLY-CAST, D.S. AND SINGLE CRYSTAL
RENÉ 150	TURBINE BLADES	DS-CAST		HIGHLY COMPLEX DIRECTIONALLY-CAST ALLOY
HA-188	COMBUSTORS	WROUGHT	HIGH USE COBALT-BASE SHEET ALLOY	

FIGURE 14

ELEMENTS OF INITIAL COSAM ACTIVITIES

PARTICIPANTS	ALLOY	NOMINAL COMPOSITION											γ'
		Ni	Cr	Cc	Mo	W	Ta	Re	Al	Ti	Hf		
COLUMBIA UNIV PURDUE UNIV SPECIAL METALS NASA-LEWIS	WASPALLOY	58	20	13	4	--	--	--	1.3	3	--	--	20%
COLUMBIA UNIV PURDUE UNIV SPECIAL METALS NASA-LEWIS	UDIMET-700	53	15	19	5	--	--	--	4.3	3.5	--	--	40%
CASE-WESTERN RESERVE UNIV TELEDYNE NASA-LEWIS	MAR-M247	60	8	10	.6	10	3	--	5.5	1	1.4	55%	
NASA-LEWIS	RENÉ 150	59	5	12	1	5	6	3	5.5	--	1.5	65%	
(TBD)	HA-188	22	22	39	--	14	--	--	--	--	--	--	

CS-80-4369

FIGURE 15

COOPERATIVE PROGRAM TO DETERMINE FUNDAMENTAL ROLE OF COBALT IN WASPALLOY AND U-700

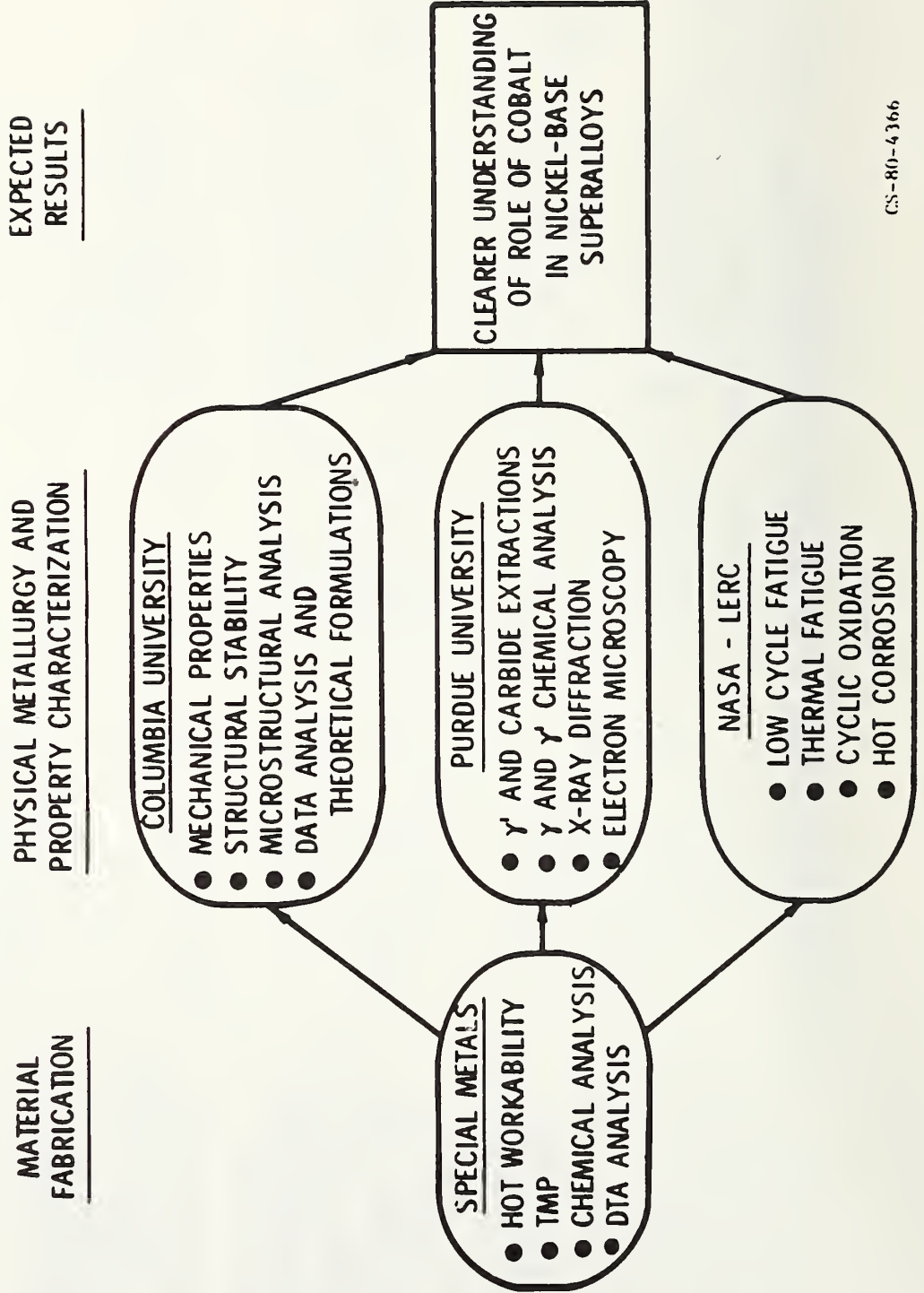

REDUCTION OF COBALT IN GAS TURBINE ENGINES

Dennis J. Evans

Pratt & Whitney Aircraft Group

REDUCTION OF COBALT IN GAS TURBINE ENGINES

BY

DENNIS J. EVANS

PRATT AND WHITNEY AIRCRAFT GROUP
COMMERCIAL PRODUCTS DIVISION
EAST HARTFORD, CT

INTRODUCTION

When gas turbine engines were initially developed, many of the highly stressed rotating or structural components were fabricated from high strength steels or, where increased temperature capability was required, simple nickel-based alloys containing chromium, and to a lesser extent aluminum or titanium and carbon were used. The earliest of the "superalloys" to be used were Hastelloy B (Ni-30%Mo-5%Fe-.12%C) and Haynes Stellite Alloys 21 and 31, both cobalt based casting alloys⁽¹⁾. Because of insufficient production capacity for refining cobalt ores, an acute shortage of the metal occurred in the United States at the time of the Korean conflict. This shortage spurred development of nickel-based substitutes for the high-cobalt alloys and, when alloyed with aluminum and titanium to form the strengthening compound gamma-prime (Ni₃Al, Ti), led to such compositions as Waspaloy and Udimet 500.

Nonetheless, these alloys still contained 10 to 20 percent by weight of cobalt, and consumed large quantities thereof, being widely used in disks, blades, and to a lesser extent in vanes. Still preferred for use in vanes were the cobalt-based alloys which possess superior thermal shock resistance. Thus, with the advent of commercial jet travel, the consumption of cobalt in superalloys for use in gas turbines increased to the point where in the late 1970's, it was the largest application for cobalt, exceeding even magnetic materials and tool or die uses. The alloy Waspaloy achieved such widespread utilization that it represents the highest tonnage use of cobalt in gas turbines⁽²⁾.

The political disturbance in Zaire, source of a majority all of the nation's cobalt supply' served to sharply focus attention on the critical nature of this element and its source of supply. Sharp cutbacks in material availability, combined with increased demand, led to dramatic price escalations beginning in 1977. Only recently has price stability been restored, but at a level many times that in effect in 1975. Many efforts were begun by industry, government and university researchers to find ways of reducing use of cobalt in gas turbine engines. This paper will discuss three approaches which have been successful in reducing consumption of cobalt-alloy substitution, alloy modification and process development.

Cobalt Applications in Gas Turbines

Three major sections of the gas turbine engine utilize the majority of cobalt. These are the high pressure compressor, combustion chamber liners, and the high pressure turbine. These areas are those portions of the engine where highly stressed components operate at temperatures of about 850°F and above - reaching to nearly 2200°F in nozzle guide vanes in the turbine section. Such operating temperatures preclude the use of iron-based alloys and, until just recently, all but the most creep resistant of titanium alloys.

The high pressure compressor utilizes static and rotating airfoils, usually forged from nickel-based alloys with varying amounts of cobalt. Also found are wrought disk alloys, used to hold the blades. Similar wrought alloys are found in the disks in the turbine section, and examples of these materials are grouped in Table I, together with their respective cobalt contents, under the heading "disk alloys".

In the turbine airfoil area, where the highest temperatures are encountered, the materials are usually cast, and consist of both cobalt and nickel-based materials. Typical examples of this category of "cast airfoil alloys" are given in Table I, where it may be seen that Inconel 713 is unique in being cobalt-free. Such was the case for Inconel 718 in the disk alloys. The category of "other wrought alloys" has been reserved for those materials typically processed into sheet, rod or bar forms for fabrication into combustor liners, flame holders and other components exposed directly to the combustion process, and thus requiring optimal corrosion, creep and thermal shock resistance. The primary alloy used in such applications is Hastelloy X, so that consumption of cobalt in these components is not so large as in disks and airfoils.

TABLE I

COBALT CONTENT OF TYPICAL TURBINE ALLOYS

Cast Airfoil Alloys

MARM 302	57.6% Cobalt
MARM 509	55.3
Rene 150	12.0
MARM 200 (Hf)	10.0
Inco 713	0

Disk Alloys

IN100, MERL 76	18.5
Astroloy	17.0
Waspaloy	13.5
Rene 95	9.0
Inco 718	0

Other Wrought Alloys

L605 (Haynes 25)	53.4
HA 188	39.0
Hastelloy X	1.5

Alloy Substitution

One of the earliest examples of alloy substitution to reduce cobalt usage is the replacement of X-40 (Stellite 31) low pressure turbine blades with nickel-base alloy blades. The Stellite 31 composition contains 56% (by weight) of cobalt, plus 25.5% Cr, 10.5% Ni, 7.5% W, 0.5% C. In the early 1960's, the cost of parts made from this air-melted cobalt alloy was less than for nickel alloys which required the more costly vacuum melting and casting practice. As can be seen in the cost trend information of Figure 1, the cobalt price escalation of 1977 caused nickel alloy blade castings to now be less costly than those of X-40.

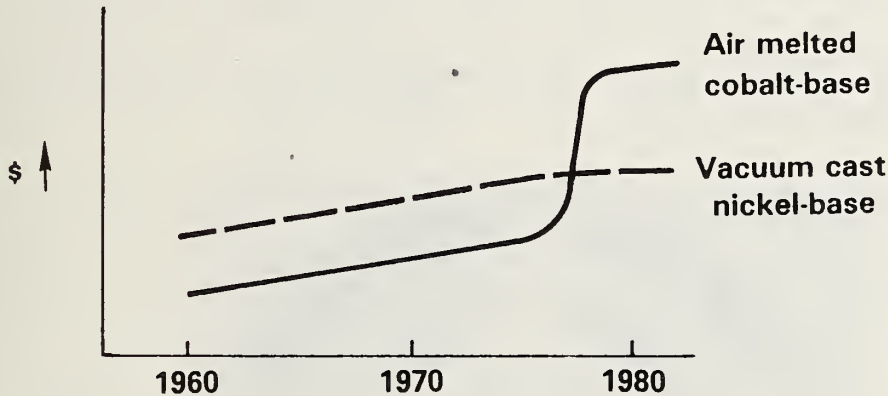

Figure 1 Cobalt Price Increase Reversed the Relative Costs of Nickel- and Cobalt-Based Cast Airfoils

A review of potential replacement alloys was made, with a total of five identified. Considerable experience had been gained in each of the nickel alloys considered - Waspaloy (13% Co) and Udimet 700 (18%) in wrought form, and IN100 (15%), B1900 (10%) and Inco 713C (0% Co) in cast form. The cobalt content of all these alloys was significantly less than that of X-40; however, the complete absence of cobalt in Inco 713C, combined with the acceptable level of mechanical properties (Table II) and in excess of 100 million part-hours service experience led to the selection of Inco 713C as a substitute for X-40.

TABLE II

Comparison of Mechanical Properties Between X-40 and Inco 713C

Property	Temp, °F	X-40	IN713C
0.2% YS	1200	60 ksi	103 ksi
%EL	1200	8%	5%
Notched HCF (10^7)	1200	24 ksi	31 ksi
Impact Strength	1200	7.0 ft-lb.	7.5 ft-lb.
0.1% Creep, 100 hr.	1400	20 ksi	60 ksi
Rupture, 100 hr.	1400	31.5 ksi	72 ksi

A major step taken toward reduced cobalt consumption through alloy substitution was the decision to incorporate Inconel 718 as a wrought disk material to replace Waspaloy. Containing 13.5% cobalt, Waspaloy represents the largest use of cobalt in commercial gas turbines. Millions of engine operating hours of successful experience have been accumulated in a large number of engine models. Because little experience in Inconel 718 wrought disks existed at Pratt and Whitney, an extensive process and material evaluation program was undertaken.

Working closely with raw material suppliers and major forging vendors, two components were selected for material and process qualification. One was a thin, compressor disk, while the other was the high pressure turbine disk for the JT8D (Figure 2). Multiple heats of raw material were evaluated in each configuration for each supplier to ensure that the disks could be processed repeatably, in a controlled manner.

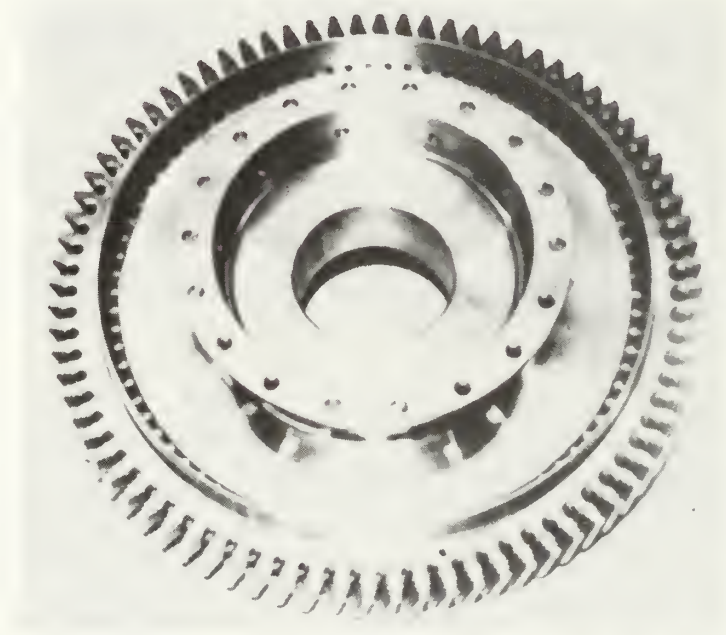

Figure 2 Typical High Pressure Turbine Disk Used to Evaluate Inconel 718 Substitution

Extensive mechanical property specimen tests were conducted to generate design allowables data in the area of tensile, creep, stress-rupture and fatigue. As seen in Figure 3, the tensile strength of Waspaloy is not significantly larger than that of Inconel 718, and the latter material has a significantly improved yield strength relative to Waspaloy. The acceptability of the tensile strength has been demonstrated through overspeed testing of full scale disks. Stress-rupture capability is of importance in components operating at elevated temperatures such as the rims of turbine disks. Inasmuch as the critical areas operate at 1100-1150°F, the wide margin in rupture capability at 1250°F (Figure 4) is not a serious drawback for most applications. In addition, results of specimen and component fatigue tests have verified the suitability of Inconel 718 for use.

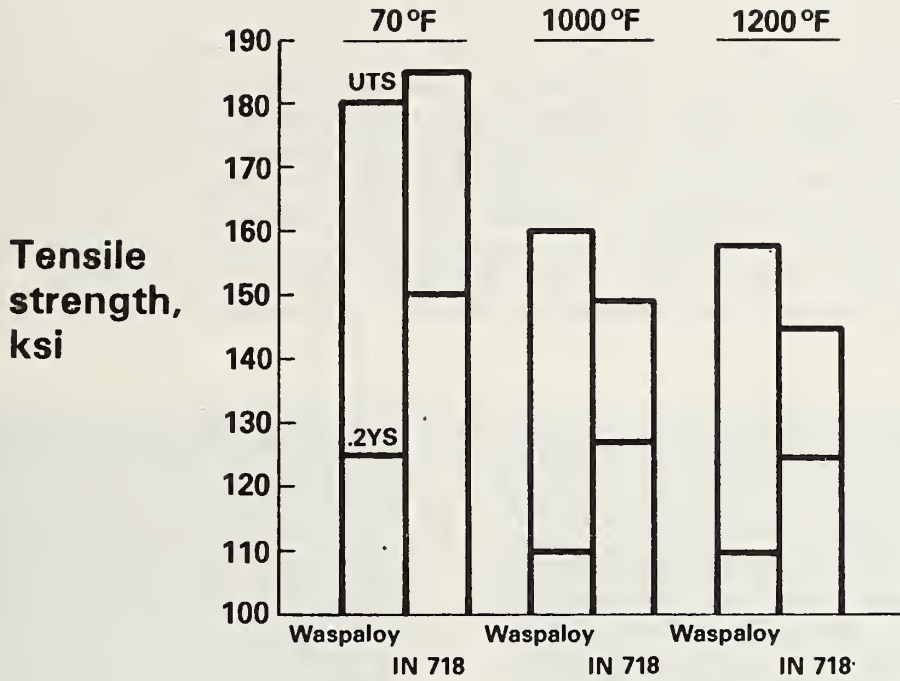

Figure 3 Tensile Strengths of Waspaloy and Inconel 718

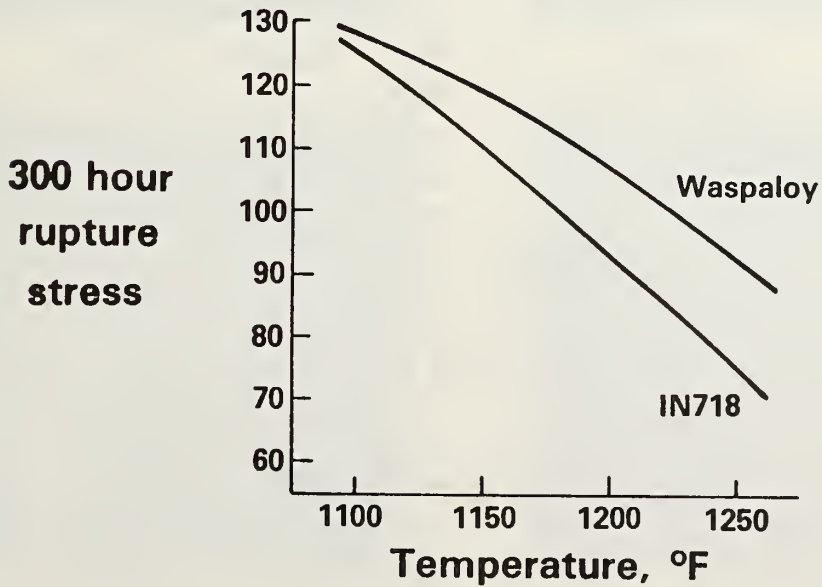

Figure 4 Comparison of Typical Stress-Rupture Properties of Waspaloy and Inconel 718

Alloy Modification

As seen in the previous section, at temperatures above about 1200°F, the stress-rupture capability of Inconel 718 is sufficiently inferior to that of Waspaloy that certain disks cannot be designed to make optimum use of Inconel 718. Better rupture capability is required. Studies both at Pratt and Whitney Aircraft and Special Metals Corporation (3) have been directed at lower cobalt modifications of Waspaloy. The objective of this research has been to define an alloy composition with adequate design properties, especially elevated temperature stress-rupture, while achieving reductions in cobalt content.

Several laboratory-sized heats of Waspaloy were prepared, with direct substitution of nickel for cobalt. Variations of cobalt content were made from the nominal 13.5% down to 8, 4, and 0% cobalt. Also varied was the amount of carbon, since work of Betteridge, et. al. (4), on Nimonic 90 indicated an effect of cobalt on carbon solubility. After forging to small, flat cylindrical shapes, which were then heat treated, an evaluation of tensile and stress-rupture properties was made. While little effect on tensile properties over the range of temperatures from 70-1200°F was noted, a strong dependence of rupture life on cobalt content was noted at both 1200 and 1350°F (Figure 5).

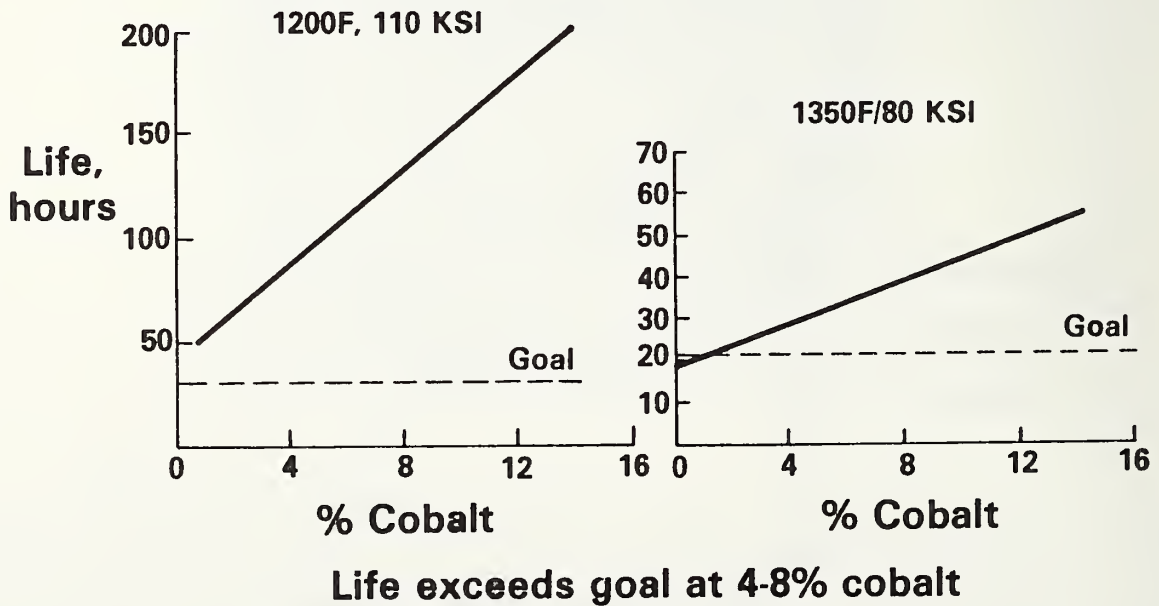
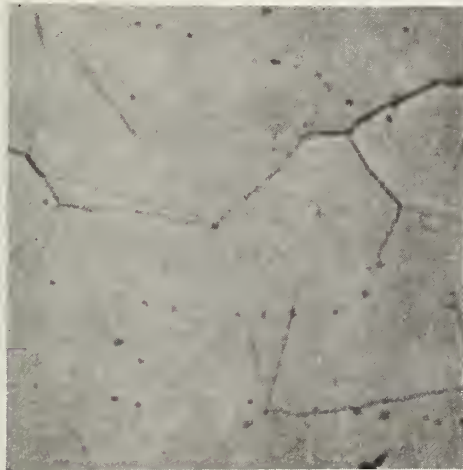

Figure 5 Effects of Carbon Content on Stress-Rupture Properties of Waspaloy

Examination of the microstructure variations resulting from modifying the nominal Waspaloy composition by replacing cobalt with nickel showed much the same trends as had been seen in the comparison of Nimonic 90 and Nimonic 80A⁽⁴⁾. With successive reductions in cobalt content, additional carbide precipitation was noted (Figure 6). This served to reduce grain size, which may have contributed to rupture life decreases. More detailed microstructural examination⁽⁵⁾ led to observation of changes in gamma-prime morphology, size and distribution, as well as changes in stacking fault energy which undoubtedly played strong roles in affecting high temperature properties. Additional work in this area is in progress under a NASA-sponsored program⁽⁶⁾.



13.5% Co (Nominal)



8% Co

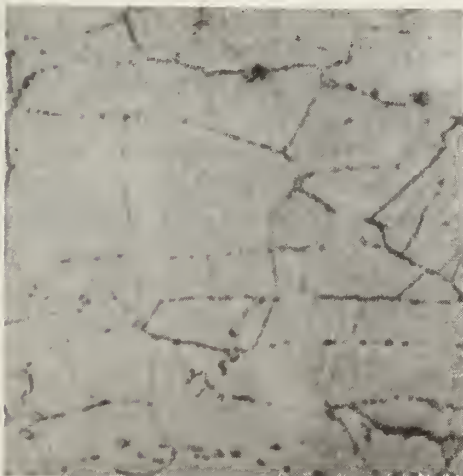

4% Co

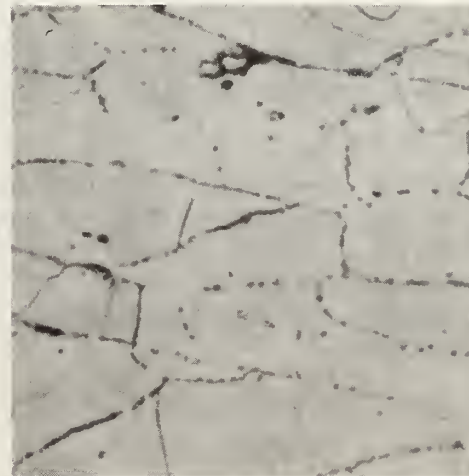

0% Co

Figure 6 Reducing Cobalt Content in Waspaloy Tends to Increase Carbide Precipitation

Net Shape Processing

The final method of reducing cobalt consumption has only recently begun to be fully explored. Use of near-net shape processing approaches such as powder metal disk fabrication by hot isostatic pressing and/or close-tolerance, isothermal forging offers new avenues of reducing use of cobalt in gas turbine components. As seen in the schematic disk cross section of Figure 7, considerable amounts of raw material are utilized in producing a conventional (non-isothermal) closed-die forging, compared with the finish-machined part.

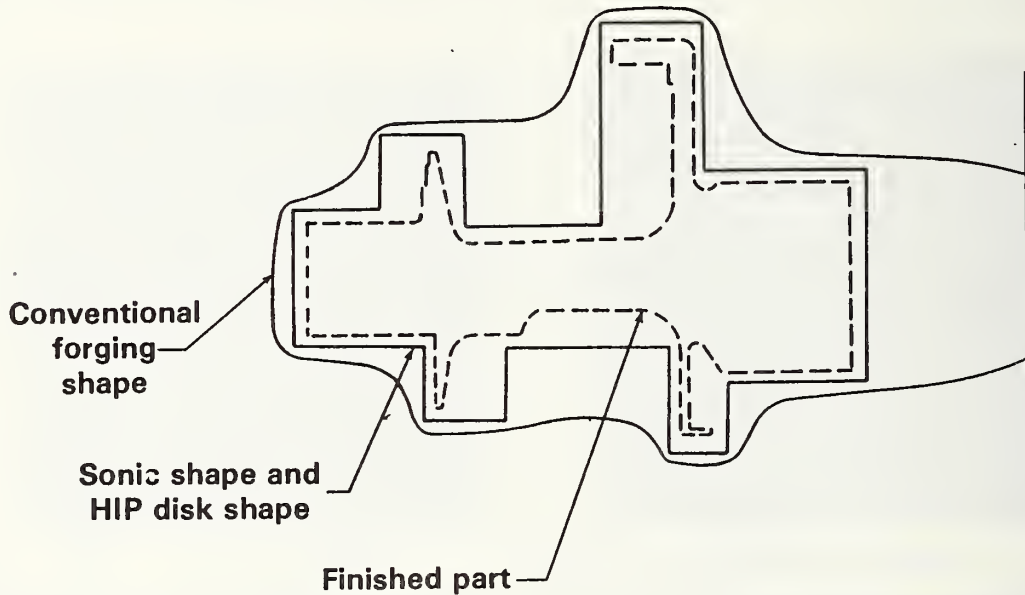

Figure 7 Cross Section of Typical Turbine Disk Forging Outline, with Near Net Sonic Shape and Finished Part Outlines

By fabricating disks to the square-cut, rectilinear configuration in which the ultrasonic inspection for quality control is conducted, significant amounts of raw material, and thus cobalt, may be conserved. In fact, as seen in Table III, it may be possible to use an alloy with a higher percentage of cobalt, and by appropriate net-shape processing, (7,8) achieve reductions of cobalt of 10% or more.

TABLE III

COBALT REDUCTION THROUGH NET SHAPE PROCESSING

<u>Alloy</u>	<u>Iput Wt.</u>	<u>% Co</u>	<u>Wt. Co</u>
Waspaloy	360 lbs.	13.5	48.6
Astroloy	250	17.0	42.5

Cobalt Savings = 6.1 lbs (12.5%)

Waspaloy	880	13.5	118.8
MERL 76	575	18.5	106.4

Cobalt Savings = 12.4 lbs (10.4%)

Future Opportunities

As can be seen from the examples cited in the foregoing section, substantial progress has been made in reducing the use of cobalt in gas turbines. One major area remaining, however, is the first stage turbine vanes, sometimes referred to as nozzle guide vanes. Cast from cobalt-based alloys such as MarM509, these components can account for up to 40 pounds of cobalt in a typical engine. The cobalt alloys are used because of their high melting points, resistance to thermal shock, and their good corrosion resistance. Inasmuch as these properties are required mainly in the airfoil section of the vane-that portion directly in the path of the hot combustion gases-it may be possible to fabricate vanes using the critical materials only in selected areas. Such a concept was discussed by Dr. J. R. Stephens⁽²⁾ of the Lewis Research Center of NASA in his presentation at the 1980 Fall Meeting of the American Society for Metals. Dr. Stephens is the program manager for NASA's COSAM (Conservation of Strategic Aerospace Materials) effort, which is presently supporting cooperative research efforts in industry, university, and government aimed at understanding the role of strategic elements and assessing methods for minimizing their use. Tailored fabrication of airfoils may be one such approach to future reduction of cobalt, and other critical materials in gas turbine engines.

REFERENCES

1. Cobalt Monograph, ed. by Centre d' Information du Cobalt, Brussels, 1960, pp. 255, 256.
2. Stephens, J. R.; NASA Technical Memorandum 81617, "NASA's Activities in the Conservation of Strategic Aerospace Materials," prepared for the 1980 Fall Meeting of the American Society for Metals, Cleveland, OH, October 28-30, 1980.
3. Maurer, G. E., L. A. Jackman, and J. A. Domingue, "Role of Cobalt in Waspaloy," Superalloys 1980, J. K. Tien, et. al., Editors, ASM, Metals Park, OH, 1980, pp. 43-52.
4. The Nimonic Alloys, ed. by W. Betteridge and J. Heslop, Crane, Russak & Co., New York, 1974, p. 78.
5. AFOSR Contract F49620-80-C-0048, "Reduction of Strategic Elements in Turbine Disk Alloys," March 1980.
6. NASA Grant NAG3-57, "Role of Cobalt in Nickel-Base Superalloys," J. K. Tien, Columbia University, New York, New York.
7. NASA CR-135409, "Manufacture of Low Carbon Astroloy Turbine Disk Shapes by Hot Isostatic Pressing," R. D. Eng and D. J. Evans, March 1978.
8. Contract F33615-77-C-5187, "Manufacturing Process for Production of Near Net Shapes by Hot Isostatic Pressing of Superalloy Powder," Interim Report 14, February 1981.

ROLE OF COBALT IN ASTROLOGY (SUPERALLOY)

John K. Tien and Robert N. Jarrett
Columbia University

"Role of Cobalt in Astroloy (Superalloy)"

John K. Tien and Robert N. Jarrett
Columbia University

Presented at the Public Workshop on
Conservation and Substitution Technology
for Critical Materials, 15-17 June 1981

1. Nickel-base superalloys are the single largest user of cobalt in the United States.
2. The role of cobalt in superalloys is not well understood.
3. Data and experience base do not exist to warrant the amount of cobalt currently in nickel-base superalloys in the United States.
4. Most of these alloys contain between 10-20% cobalt by weight.
5. Many Soviet and Chinese superalloys contain almost no cobalt.
6. In the past cobalt price was comparable to, and at times even less than, the price for nickel. This might have been a major driving force in the copious introduction of cobalt in the nickel-base superalloys in the United States.
7. Columbia University (in conjunction with NASA-Lewis Research Center, Purdue University and Special Metals Corporation) is in the first year of a three-year program to understand the role of cobalt in nickel-base superalloys in order to effect the prudent substitution of cobalt with such less critically strategic elements as nickel.
8. The alloys chosen for research concentration are Udimet 700 (Astroloy) with nominally 17-19% cobalt content and Waspaloy with 15% cobalt (the compositions of alloys found in Table I).

9. Data Obtained so far strongly indicate cobalt has little effect on the tensile strengths and ductility of either alloy; see, for example, Figs. 1 and 2.

10. High temperature creep and stress rupture resistances are found to be lowered as cobalt is removed from the alloys. However, this decrease does not become significant until, for example, more than half the cobalt is removed from the fine grained Udimet 700 studied; see, for example, Fig. 3 and Fig. 4.

11. Detailed and very fine spot size microchemistry determinations in the scanning-transmission electron microscope show that cobalt rests mostly in the continuous matrix part of the alloy and not in the strengthening precipitates; see, for example, Fig. 5 and Fig. 6. This can explain why removing cobalt does not result in brute strength loss. The decrease in creep and stress rupture resistances at very low cobalt levels can be due to cobalt's influence on the stacking fault energy of the matrix. This decrease is not expected in every nickel-base superalloy, since many nickel-base superalloys are not as dependent on their matrices as Udimet 700 and Waspaloy.

12. Results also show heat treatment can affect and under certain conditions nullify cobalt's influence.

13. Tests in progress include determining the role of cobalt on fatigue, thermal fatigue, oxidation and hot-corrosion, and other properties relevant to the use of superalloys in jet engines and other critical applications.

14. A comprehensive report on the findings of this program is expected by early 1982.

TABLE I COMPOSITIONS OF THE ALLOYS STUDIED (IN W/O)

HEAT No.	NI	Co	CR	Mo	TI	AL	C	B	FE
D5-1884	72.1	< .1	15.1	5.0	3.5	4.12	.06	.025	.11
D5-1885	67.7	4.3	15.1	4.9	3.6	4.14	.07	.024	.15
D5-1886	63.6	8.6	15.0	5.1	3.5	4.05	.06	.022	.11
D5-1932	59.6	12.8	14.7	5.0	3.6	4.10	.06	.023	.12
D5-1933	55.2	17.0	14.9	5.0	3.6	4.08	.06	.028	.11

O < 10 PPM

N < 16 PPM

S < 20 PPM

BI, IH < 0.1 PPM

PB, TL, CA < 0.2 PPM

FIGURE 1 - Ambient Temperature Tensile Properties of Astroloy

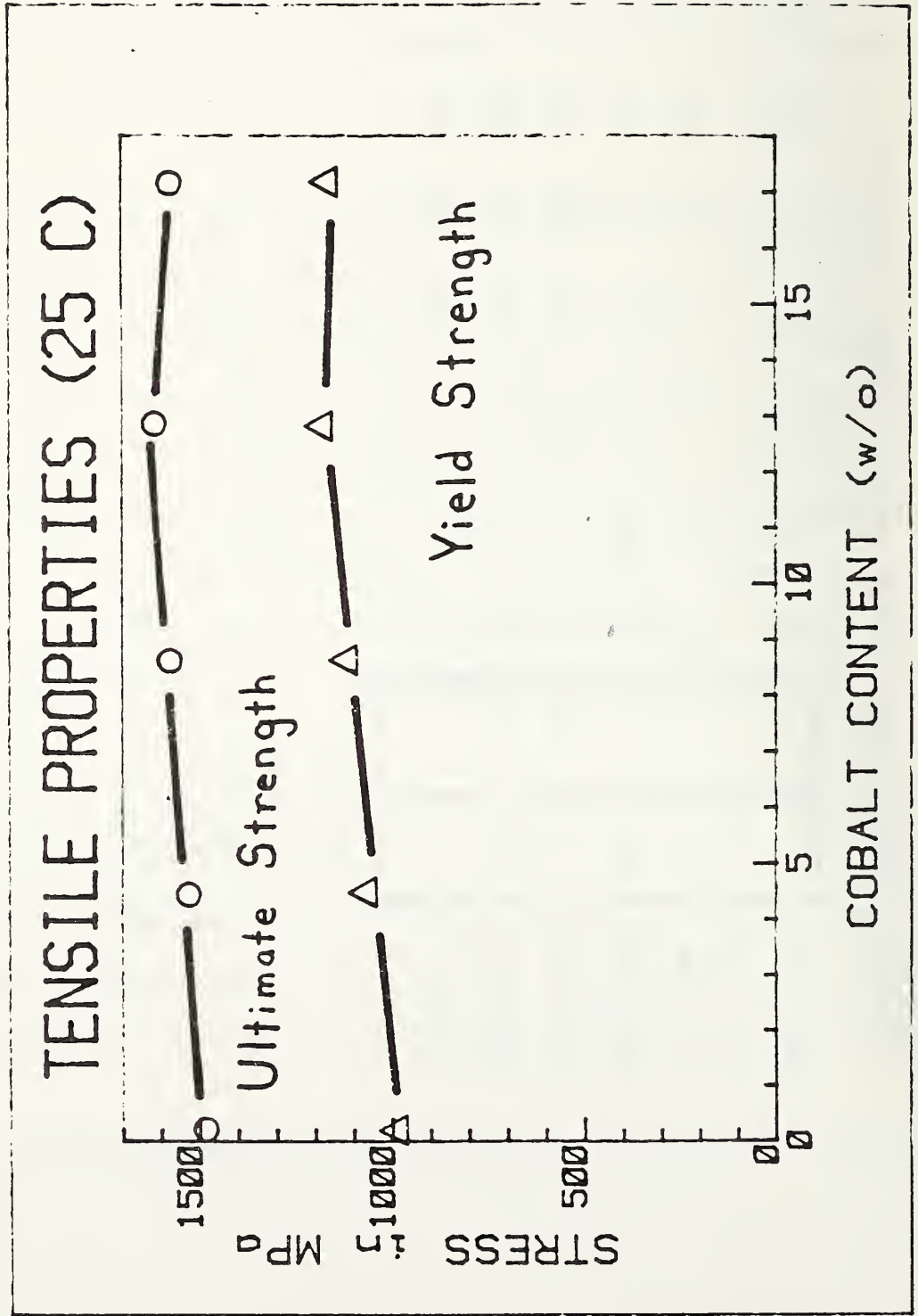

FIGURE 2 - Ambient Temperature Tensile Ductility of Astroloy

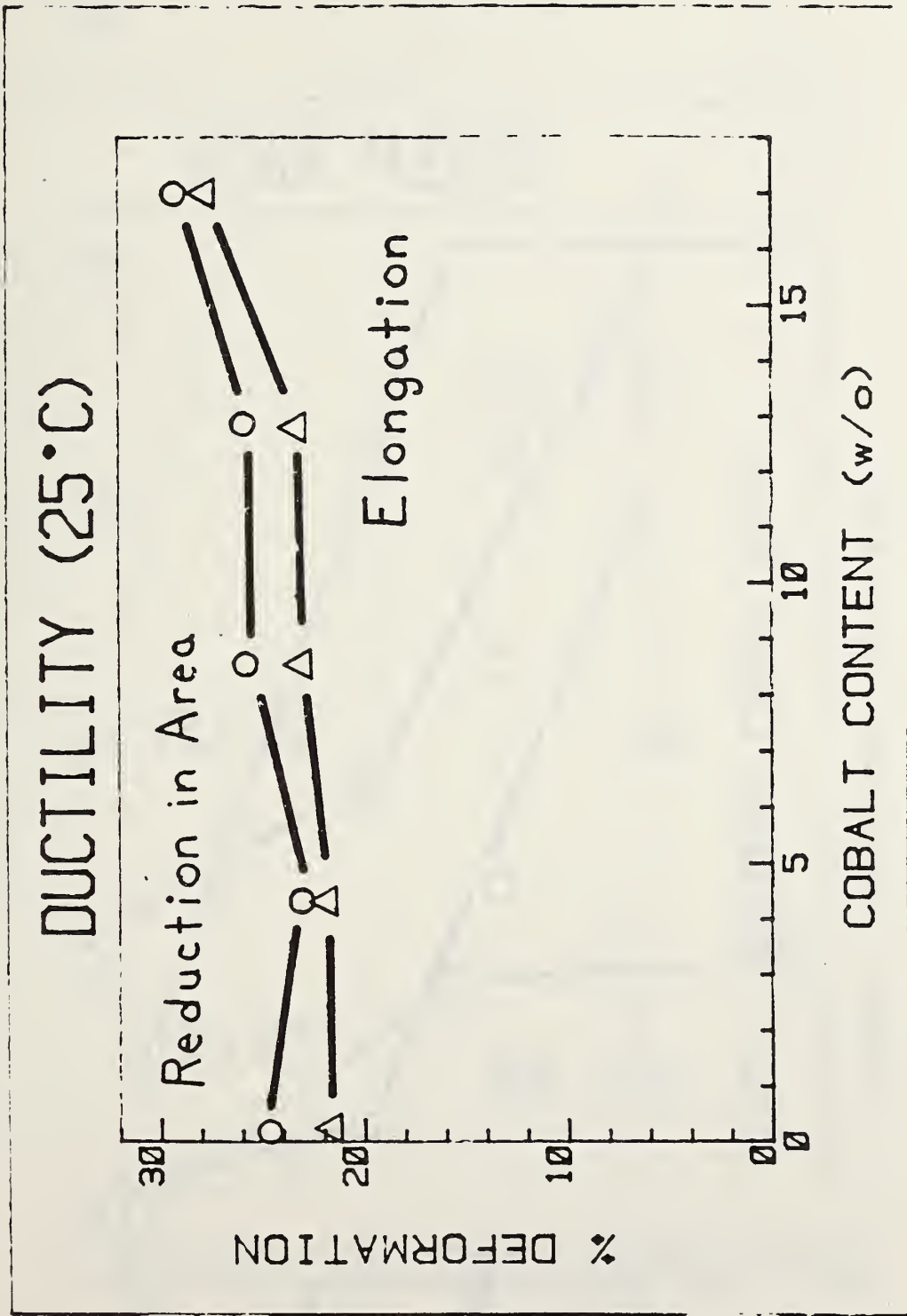

FIGURE 3 - Creep of Cobalt Modified Astroloy

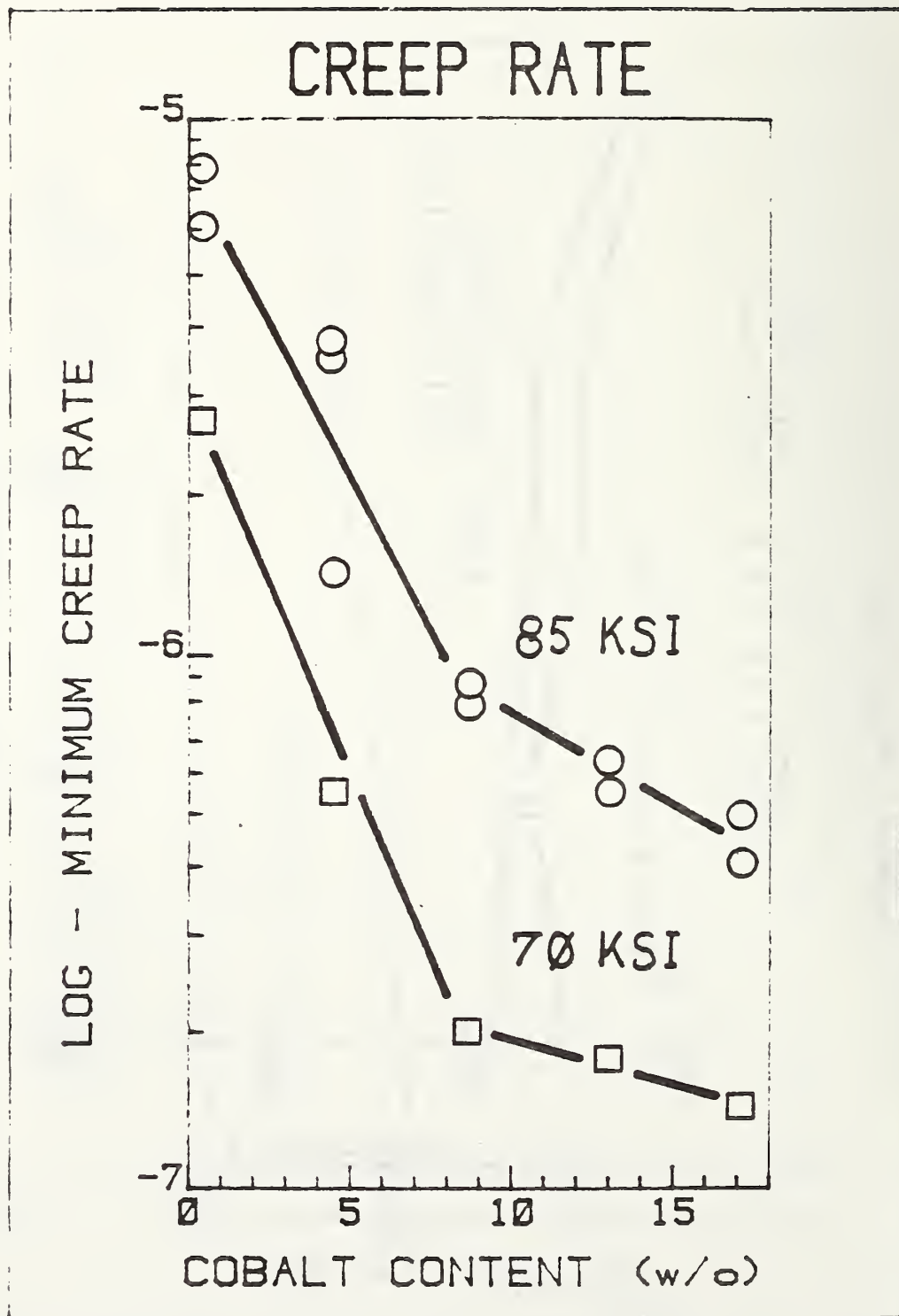

FIGURE 4 - Stress Rupture of Cobalt Modified Astroloy

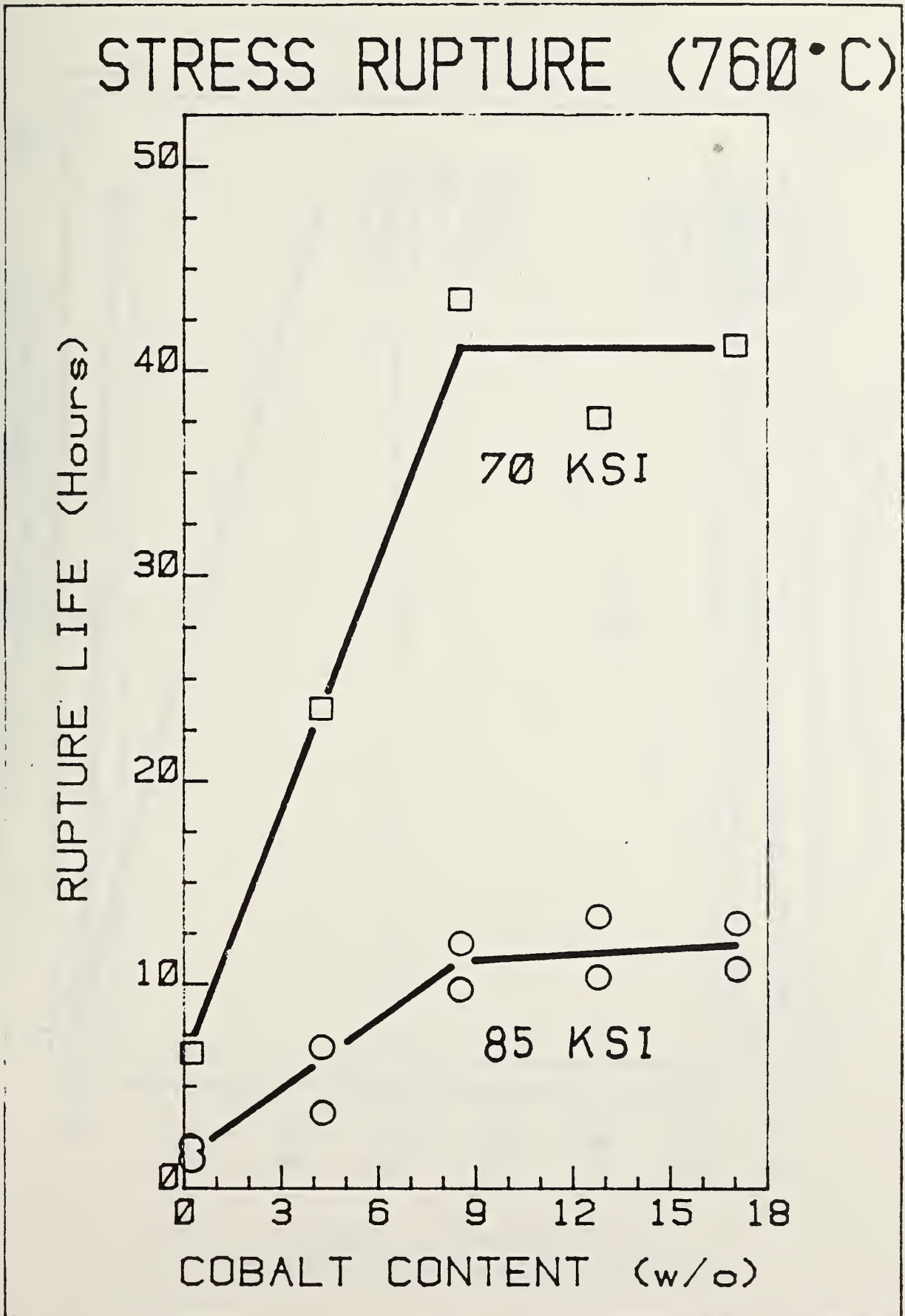

FIGURE 5 - STEM/EDAX Analysis of the Matrix
in Modified UDIMET 700

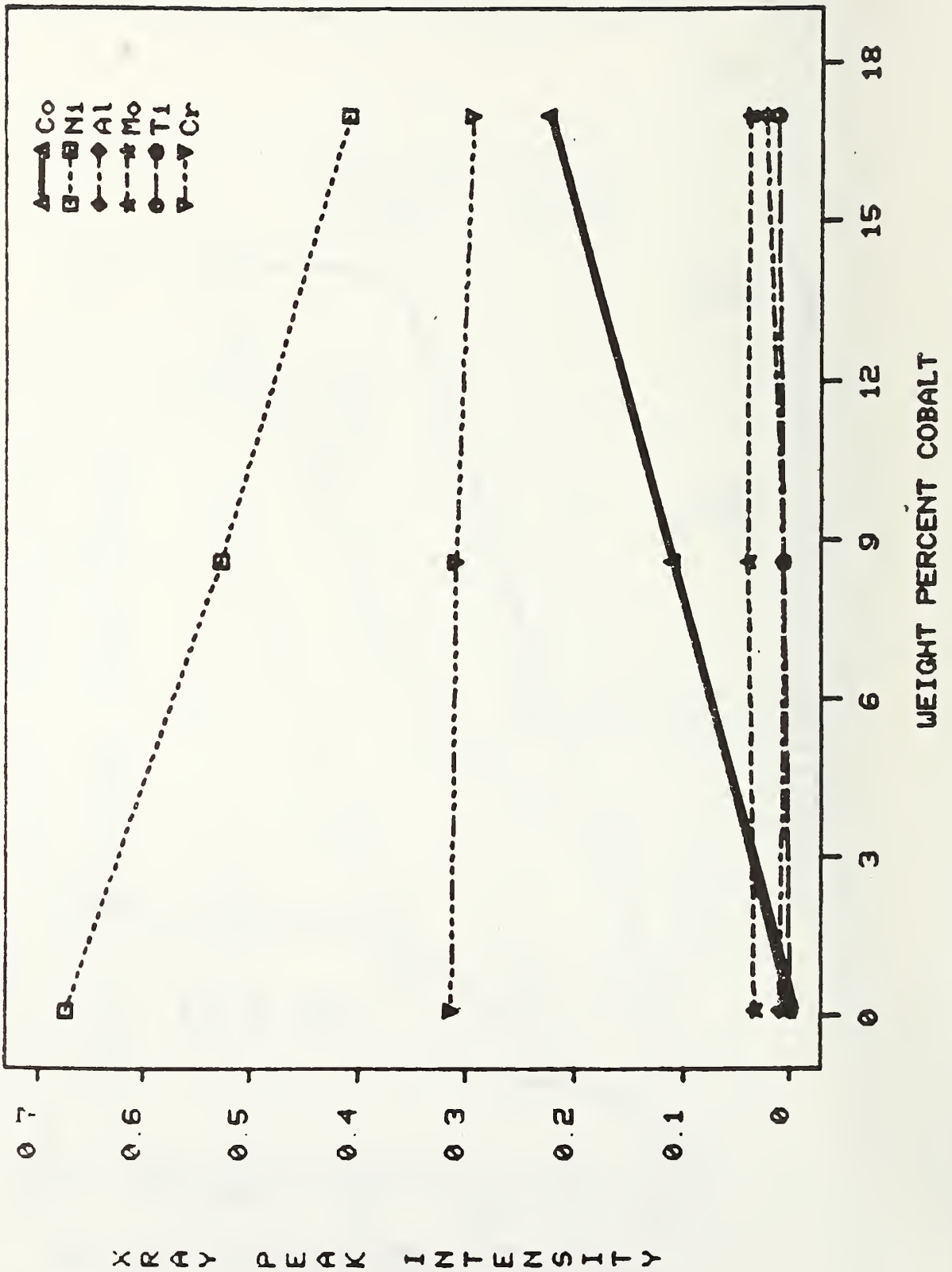
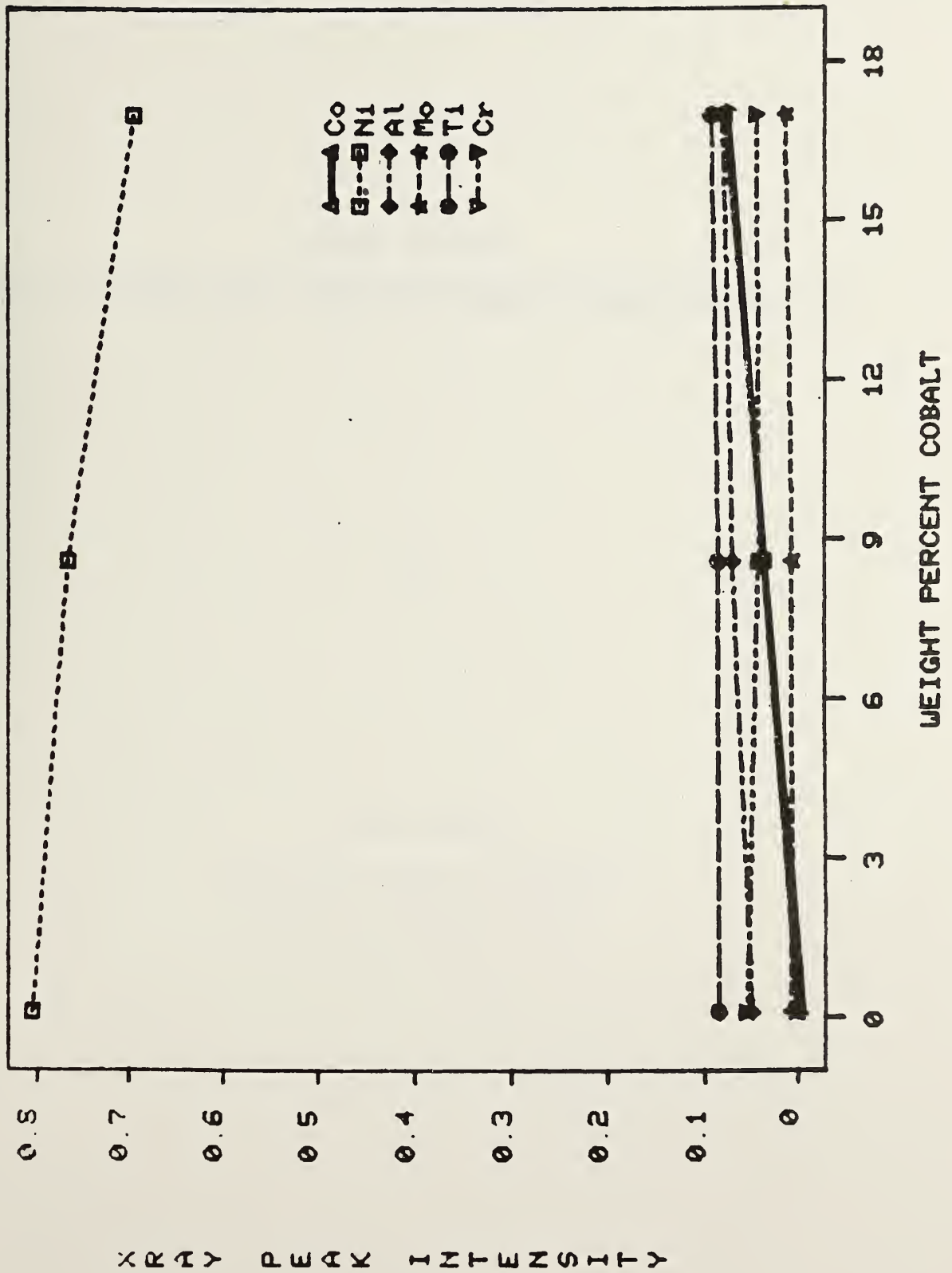

FIGURE 6 - STEM/EDAX Analysis of the Fine Gamma
Prime in Modified UDIMET 700



PROGRESS IN REDUCTION OF COBALT IN MAR-M247

Michael Nathal

Case Western Reserve University-NASA Lewis Research Center

Progress in Reduction of Cobalt in Mar-M247

by

Michael Nathal

Case Western Reserve University

NASA Lewis Research Center

INTRODUCTION

This work was funded by NASA Lewis Research Center.

The purpose of this investigation was to determine the influence of Co on the microstructure and mechanical properties of Mar-M247, a nickel-base superalloy. As one can see from the composition of Mar-M247, Figure 1, superalloys are complex alloys, consisting of as many as a dozen elemental additions to the nickel base. Throughout the years, an understanding of the role of most of these elements has been reached. The role of Co, however, is not well understood. Recent increases in price and limitations of supply provide considerable incentive for understanding cobalt's functions, with the goal of eliminating or reducing its role in superalloys.

The approach used in this study was to establish the properties of equiaxed grained castings of the standard 10 percent Co version of Mar-M247, along with 0 and 5 percent Co versions. Nickel was substituted for Co to produce the low Co alloys. Grain size and heat-treatment were kept constant prior to mechanical testing. Tensile tests were performed between 649°C and 982°C. Stress-rupture tests were performed between 760°C and 982°C.

RESULTS

Microstructure

Figure 2 shows that Co has a significant effect on the microstructure of Mar-M247. The figure on the left shows that the weight fraction of γ' , as determined by electrolytic phase extraction, decreases from 59 to 41 percent as Co is removed. The figure on the right shows that the amount of carbides is also a function of Co. The weight fraction of carbides increases from 2 to 3 percent as Co is removed. This increase in the amount of carbides promotes the formation of a carbide film along the grain boundaries of the 0 and 5 percent Co versions.

The composition, as well as the amounts, of the phases are also a function of Co level, as illustrated in Figure 3. The figure on the left shows the composition of the γ' phase as a function of Co level in the bulk alloy. Important features of this figure is the increase in W and Ti contents in the γ' as Co is removed. Tungsten increased from 5 to 8 atomic percent, and Ti from 2 to 3 atomic percent as Co was removed. The figure on the right shows the composition of the γ phase. Note the decreases in the Cr and Al concentrations in the γ as Co is removed from Mar-M247.

These changes in composition would serve to change the solid solution hardening of the γ and γ' phases. The increases of W and Ti in the γ' would increase the strength of the γ' , mainly through increasing the APB energy. The Cr and Al decreases in the γ would serve to weaken the matrix phase.

Because Co is a weak solid solution hardener of Ni, the reduction in Co content is not expected to alter the strength of either the γ or γ' . Thus, as Co is removed from Mar-M247, the γ' phase becomes stronger, but the γ matrix becomes weaker.

Tensile Properties

The summary of the tensile tests is presented in Figure 4. All three alloys exhibit typical temperature dependence, with the yield strength remaining fairly constant, followed by a rapid drop-off near 800°C. Note that the 5 percent Co alloy showed a 12 KSI increase in yield strength over the other two alloys, and the very small differences between the 10 percent Co and the 0 percent Co versions of Mar-M247. Also of interest is the negative shift in the peak strength temperature as Co is removed. This shift is consistent with the increases in W and Ti concentration in the γ' discussed earlier.

Replotting the yield strength as a function of Co level, Figure 5, again shows the peak in strength at the 5 percent Co level. This peak is on the order of 10 percent of the total yield strength, and is evident only at temperatures below 760°C. Also evident from Figure 5 is the very small differences in strength between the 0 and 10 percent Co versions of Mar-M247.

In addition to the yield strength, the ultimate tensile strength exhibited similar temperature and alloying dependence. Tensile ductility, as illustrated in Figure 6, was not a strong function of Co level.

Stress-Rupture Properties

Figure 7 is a summary of the stress-rupture tests, performed at 760, 871, and 982°C.

In this plot of applied stress as a function of Larson-Miller Parameter, a reduction in life is evident at all temperatures. Rupture ductility was not a strong function of Co, as illustrated in Figure 8.

Figure 9 shows the stress-rupture behavior at 871°C as a function of Co level in Mar-M247. Rupture life is seen to decrease from 110 to 40 hours at 60 KSI, and from 265 to 90 hours at 52 KSI as Co is removed. These data are consistent with the reduction in γ' volume fraction discussed earlier, but Figure 10 shows that the creep behavior is not so simply related. This plot shows that the minimum, or steady-state creep rate, remains constant as Co level is reduced from 10 to 5 percent, before increasing rapidly as further Co is removed. This behavior is unusual, for alloys that exhibited a decrease in rupture life, as shown in Figure 9, would be expected to exhibit a corresponding increase in creep rate. This is seen to be true for the 0 percent Co alloy, where both the creep rate and rupture life are affected. But this is not true for the 5 percent Co alloy, which exhibited a creep rate equal to that of the 10 percent Co alloy. Another way to analyze these data is to examine the creep curves produced, as in Figure 11. In this figure, it is seen that both the 5 and 10 percent Co versions exhibit essentially the same creep behavior until late in the test, when the 5 percent Co alloy enters third stage creep earlier. The 0 percent Co alloy shows both the reduced rupture life and increased creep rate compared to the 10 percent Co alloys.

This behavior can be rationalized in terms of the microstructural changes in Mar-M247. One feature expected to be of importance in creep resistance is the γ' volume fraction, which was observed to decrease from 59 to 41 percent as Co was removed, Figure 2. Such a reduction would be expected to increase the creep rate and decrease the rupture lives of the alloys, This is seen to be true for the 0 percent Co alloy, but not for the 5 percent Co alloy, and other factors must be considered. Another feature considered to be of importance in determining creep-resistance is grain boundary morphology. As mentioned earlier, the 0 and 5 percent Co alloys exhibited a continuous grain boundary film, while the 10 percent Co alloy exhibited discrete carbide particles decorating the grain boundary. It is postulated here that the presence of the grain boundary carbide film causes an increase in creep crack initiation and propagation.

Concluding Remarks

In summary, the removal of Co did not significantly alter the tensile properties of Mar-M247. The creep-rupture properties, however, were more significantly affected. Removal of 5 percent Co reduced rupture life but did not affect minimum creep rate. Removal of all 10 percent Co deleteriously affected both creep rate and rupture life.

In light of these results, I believe that potential exists for use of low Co versions of Mar-M247 in gas turbine engines, with modification. Two modifications that seem to be promising are: 1. lowering the carbon content to eliminate the carbide morphology problem, 2. using the alloys in single crystal form, also to eliminate the grain boundary carbide morphology problem.

MATERIAL: EQUIAXED GRAINED MAR-M247

Ni Co Cr Al Ti W Ta Hf Mo C

BAL. 10 8.5 5.5 1.0 10 3 1.5 0.8 .15

**NI SUBSTITUTED FOR CO TO PRODUCE
0% AND 5% CO VERSIONS**

**APPROACH: TENSILE TESTS BETWEEN 650°
AND 980°C. STRESS-RUPTURE TESTS
BETWEEN 760° AND 980°C.**

Figure 1.

Figure 2.

AMOUNTS OF PRECIPITATES IN MAR-M247

AS A FUNCTION OF COBALT CONTENT

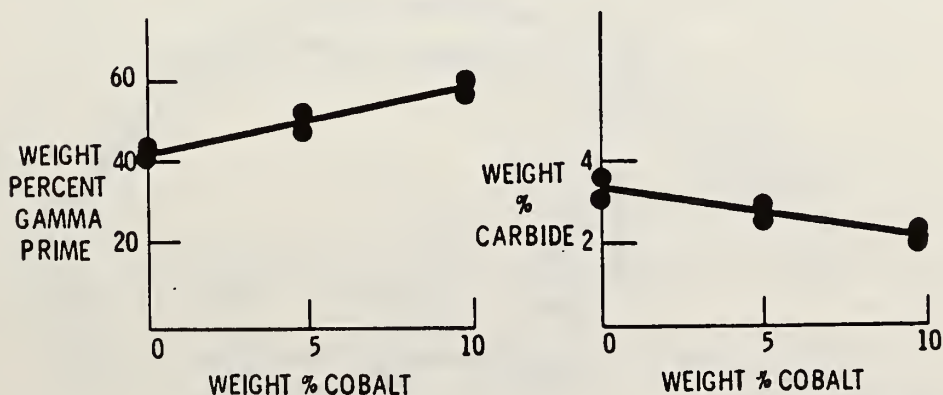

CS-81-734

COMPOSITION OF GAMMA AND GAMMA PRIME AS A FUNCTION OF COBALT CONTENT IN THE BULK ALLOY

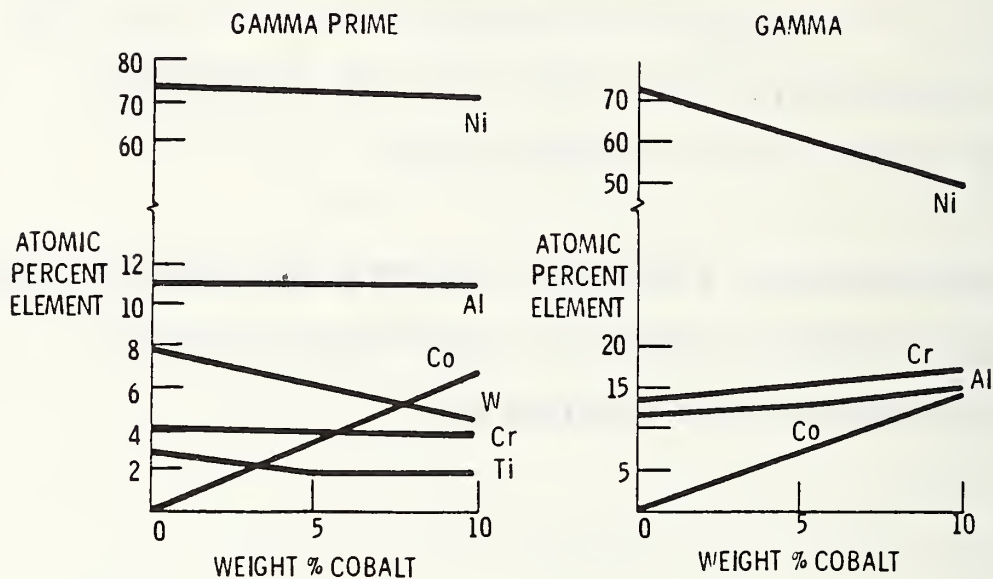

CS-81-733

Figure 3.

Figure 4.

YIELD STRENGTH OF MAR-M247 WITH SEVERAL COBALT LEVELS.

AS A FUNCTION OF TEMPERATURE

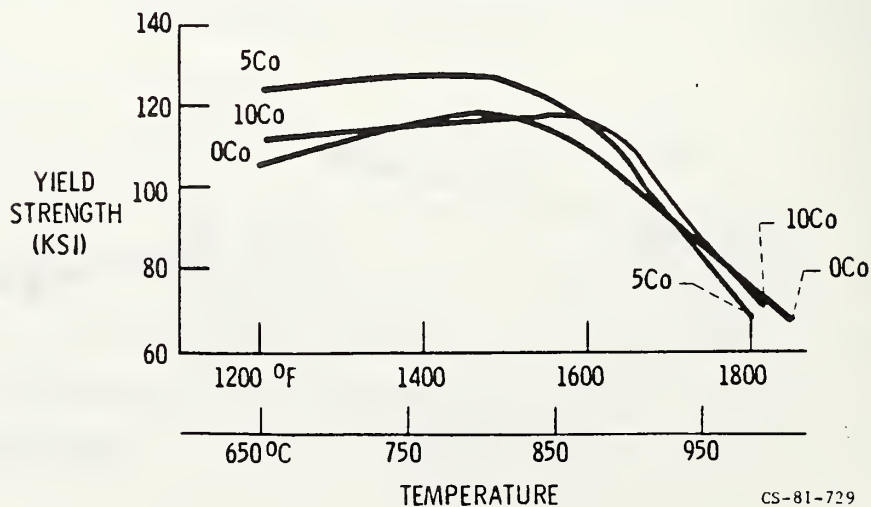

CS-81-729

YIELD STRENGTH OF MAR-M247 FROM 649° C (1200° F) TO 982° C (1800° F)

AS A FUNCTION OF COBALT CONTENT

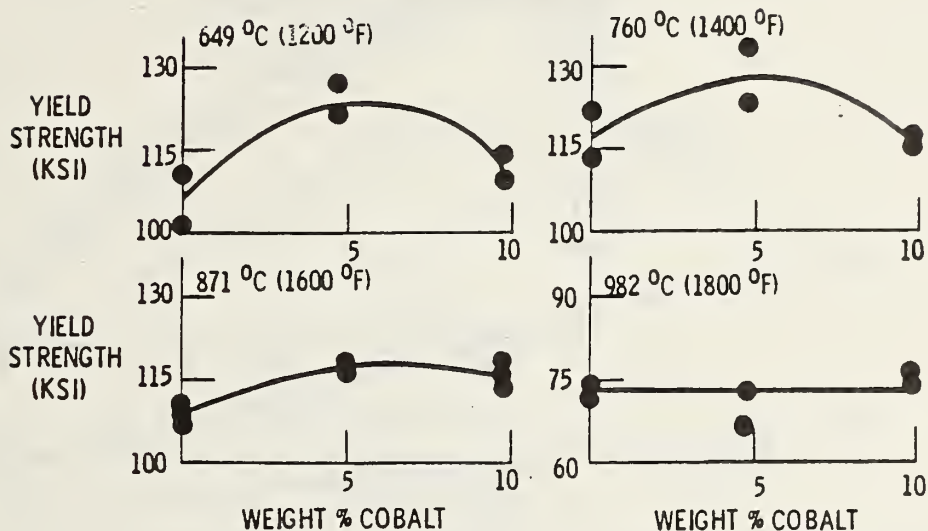

Figure 5.

CS-81-739

Figure 6.

TENSILE DUCTILITY OF MAR-M247 FROM 649° C TO 982° C

AS A FUNCTION OF COBALT CONTENT

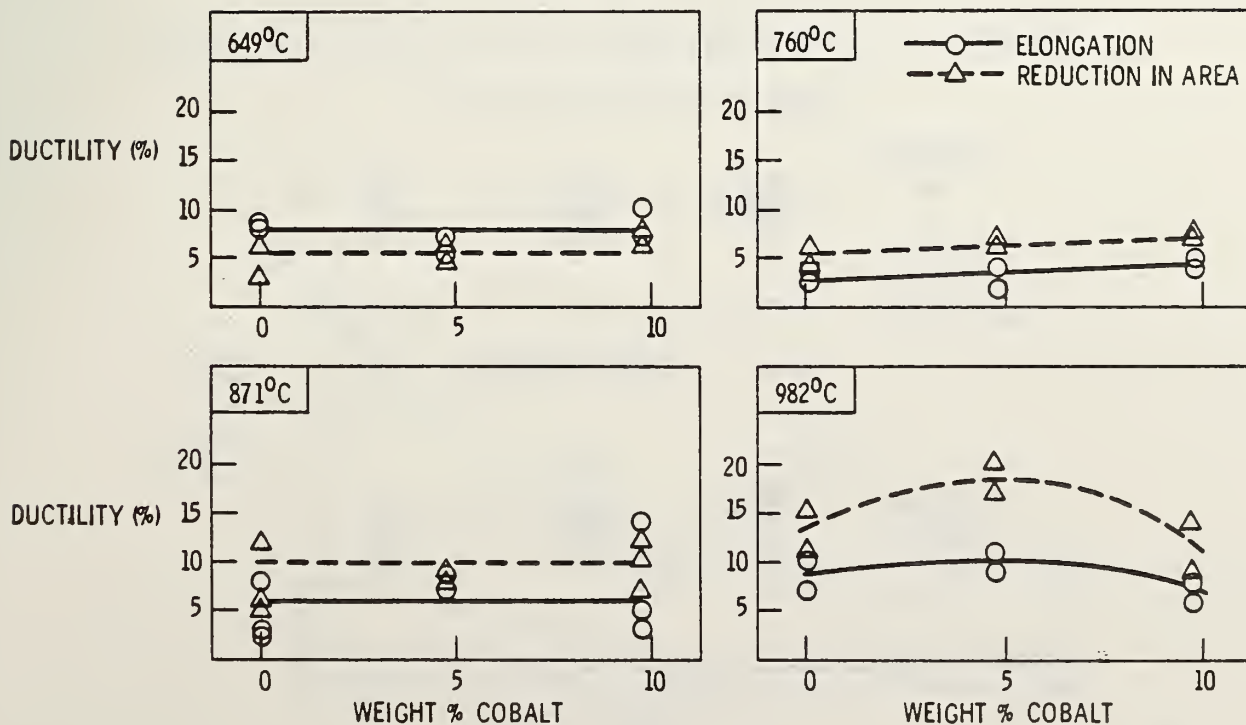

CS-81-2592

LARSON MILLER PLOT FOR MAR-M247

WITH 3 COBALT LEVELS

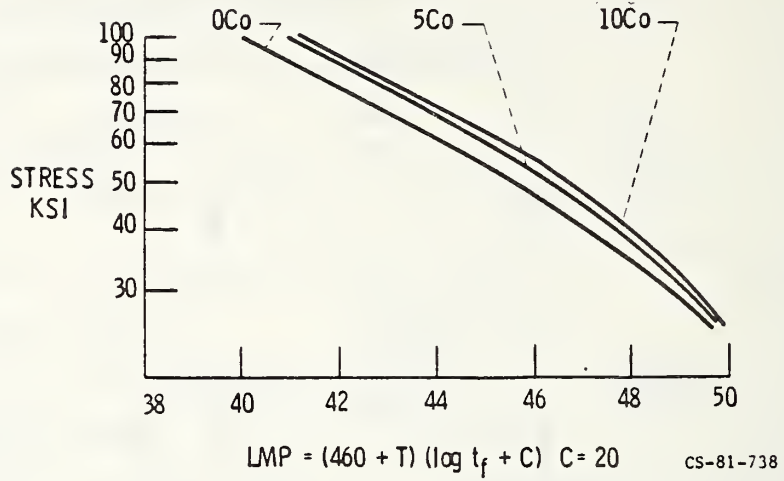
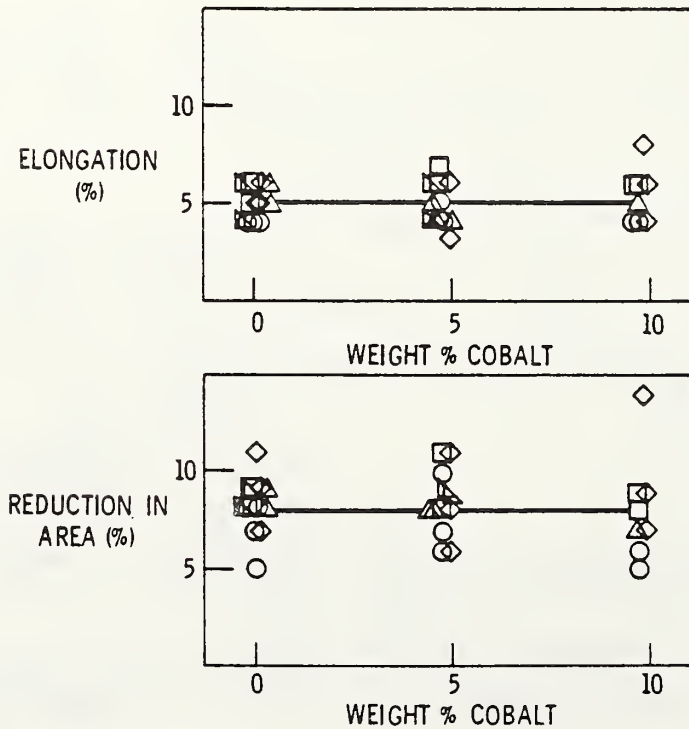

Figure 7.

Figure 8.

STRESS-RUPTURE DUCTILITY OF MAR-M247

AS A FUNCTION OF COBALT CONTENT



CS-81-2593

STRESS-RUPTURE LIFE OF MAR-M247

AT 871° C (1600° F)

AS A FUNCTION OF COBALT CONTENT

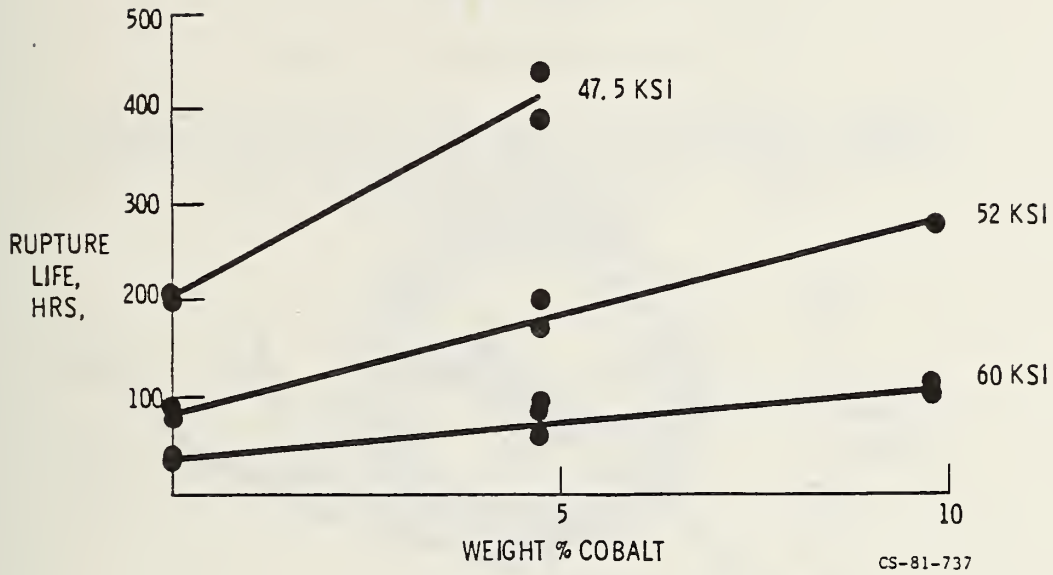
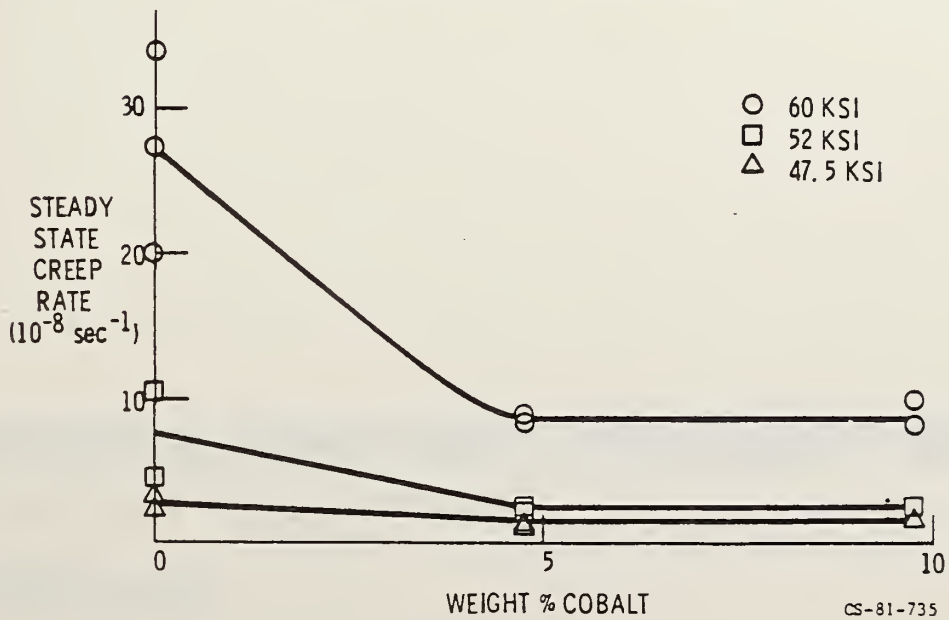

Figure 9.

Figure 10.

STEADY STATE CREEP RATE OF MAR-M247 AT 871° C (1600° F)

AS A FUNCTION OF COBALT CONTENT



MODEL CREEP CURVES FOR MAR-M247 WITH DIFFERENT COBALT CONTENTS

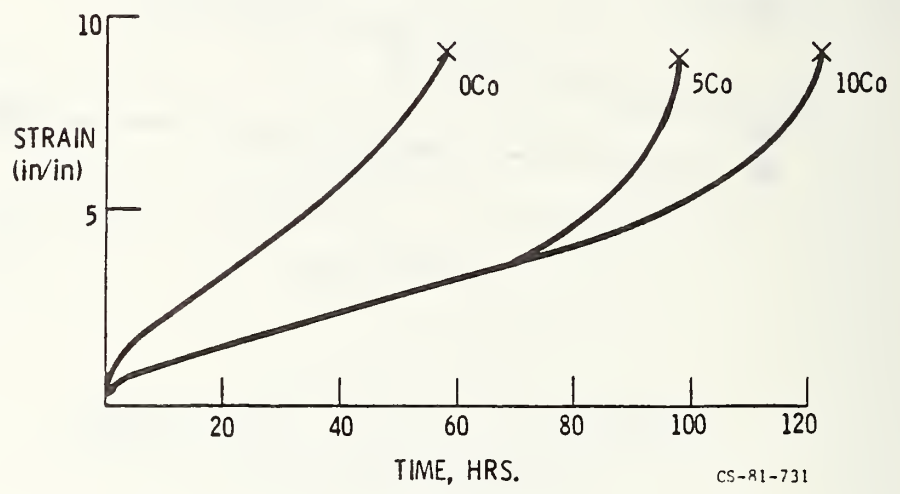

Figure 11.

REDUCTION OF STRATEGIC ELEMENTS IN
TURBINE DISK ALLOYS

FINAL REPORT

March 1, 1980-February 28, 1981

UNITED STATES AIR FORCE OFFICE OF SCIENTIFIC RESEARCH
BUILDING 140
BOLLING AIR FORCE BASE, D.C. 20332



PREPARED BY:

C. C. LAW, L. S. LIN, AND M. J. BLACKBURN
MATERIALS ENGINEERING & RESEARCH LABORATORY

8-767-4931

PRATT & WHITNEY AIRCRAFT GROUP

Government Products Division

P O Box 2691
West Palm Beach Florida 33402



SUBSTITUTION FOR COBALT IN HIGH SPEED STEELS-
ROLE OF PROCESSING INNOVATION

Walter T. Haswell Jr.
Colt Industries/Crucible Inc.

CONSERVING COBALT

SUBSTITUTION FOR COBALT IN HIGH SPEED STEELS -
ROLE OF PROCESSING INNOVATION

W. T. Haswell
Colt Industries/Crucible Inc.

SUBSTITUTION FOR COBALT IN HIGH SPEED STEELS -
ROLE OF PROCESSING INNOVATION

The Crucible Particle Metallurgy process was developed by the Crucible Material Research Laboratory and has been commercially applied to the production of specialty steels at the Crucible Specialty Metals Division in Syracuse, New York since 1970. This process enables us to produce a superior quality product in standard analysis high speed steels and also provides great opportunity for new alloy development based on the virtual elimination of segregation made possible by the CPM process.

In mid-1978, the Katanganese invasion of Zaire seriously disrupted the cobalt supply to the rest of the world. Cobalt became a scarce and expensive metal. The United States imports about 97% of its cobalt supply. This cobalt scarcity threatened to interrupt the production of cobalt-containing high speed steels which are primarily used in machining difficult-to-machine superalloys and titanium used by the aircraft and aerospace industries.

At Crucible, we immediately started a research program to determine if through the unique segregation control of the CPM process we could develop alloys offering equivalent metallurgical properties and cutting tool performance to the cobalt-containing conventional super high speed steels. This has been successfully accomplished and two new cobalt-free super high speed steels, Rex 25 and Rex 20, are now commercially available.

The Crucible Particle Metallurgy (CPM) Process

Before discussing the development of cobalt-free HSS, a brief description of the CPM process is necessary. The principal elements of the process are shown schematically in Figure 1. The basic process

Particle Metallurgy Processing

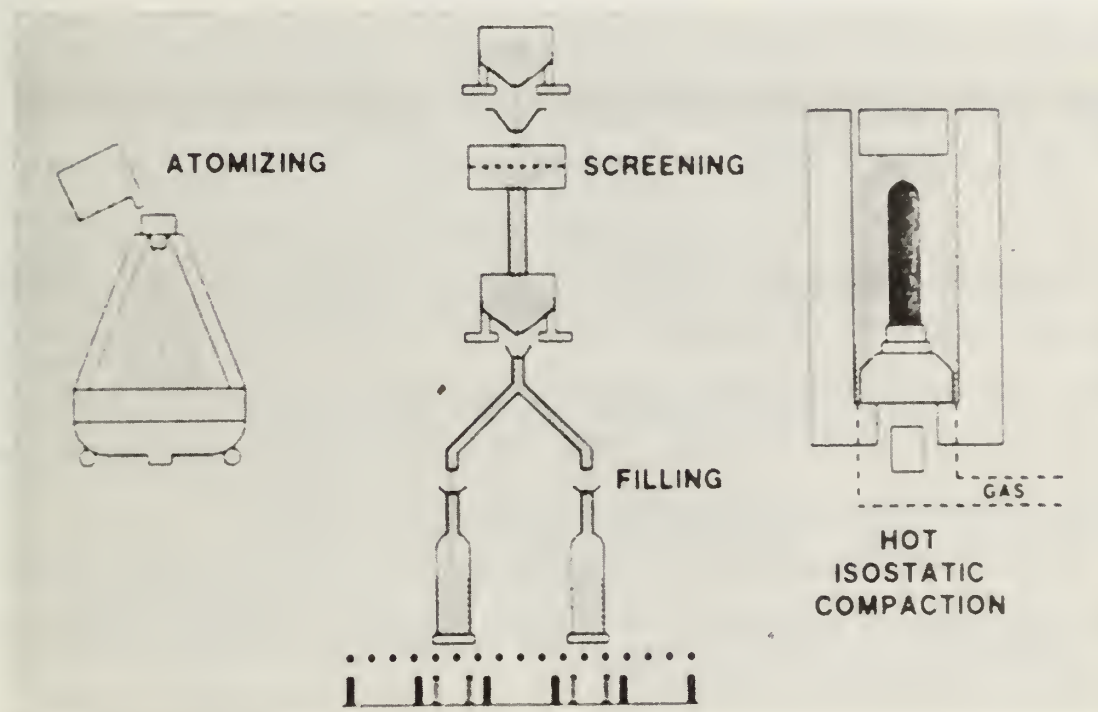
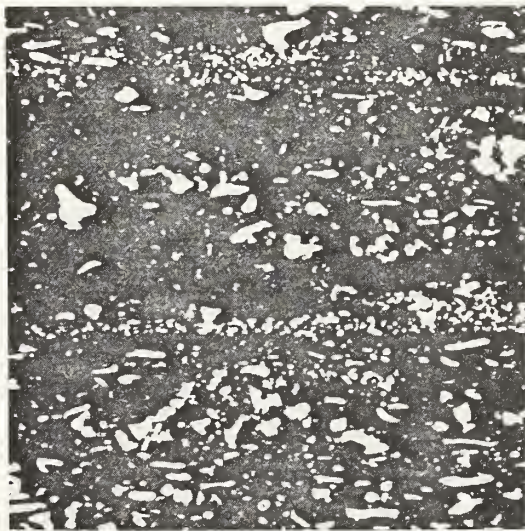

Figure 1 - Particle Metallurgy Processing

consists of induction melting and atomizing pre-alloyed particles, screening and canning these particles, and finally hot isostatic pressing to full density. The induction heat of the desired chemical composition is melted and the molten stream is poured into an atomizing chamber where high pressure gas jets disperse the molten stream into spheroidal droplets which are rapidly quenched to ambient temperature. The powder is removed from the atomizing chamber, dried and screened to obtain the desired size fraction. It is then poured into cylindrical steel cans which are evacuated and sealed. The cans are subsequently heated to a specific temperature and hot isostatically compacted to achieve a fully dense product. The compacts are processed to the desired billet and bar sizes on conventional mill facilities.

Typical microstructures of conventional and CPM T15 high speed steel are shown in comparison with conventionally produced product of the same composition. Figure 2.

Figure 2



Conventional Product



CPM Product

Primary carbides in microstructure of T15.
Photomicrographs taken at mid-radius location
on longitudinal sections of 2-in.-dia. bars.
Hardened condition .250X.

The outstanding features observed are the homogeneity, particularly in contrast to the segregation found in conventional ingot cast HSS, and a fine uniform primary carbide distribution. The primary carbide size distributions in CPM and conventionally produced T15 have been measured. Virtually all carbides in CPM HSS have a diameter less than about 3 μm , whereas those in the conventional product cover the entire size range to $\sim 34 \mu\text{m}$ with a median size of 6 μm .

The principal advantages of PM HSS and the CPM process may be summarized as follows:

- (a) Superior grindability in the hardened condition.
- (b) Improved toughness.
- (c) Faster response to hardening heat treatment and better cross-sectional uniformity of hardness.
- (d) More uniform size change (less out-of-roundness) through heat treatment.
- (e) The ability to make more highly alloyed steel compositions than is possible with conventional ingot cast product.

CPM Rex 25 and CPM Rex 20 Alloy Development

Our alloy development program began with a review of the existing high speed tool steel compositions to note the various combinations of elements which are contained in currently available commercial grades. The compositions were examined in two groups - the high tungsten versions or the T series, and the high molybdenum versions or the M series. Because of the wide compositional range represented by these alloys, a common denominator was sought for comparison and analysis purposes. The tungsten equivalency concept has been a popular means of comparing HSS compositions and thus, in our review, we used the relationship:

Tungsten equivalency, $W_{eq} = \%W + 2 (\% Mo)$.

It was also realized that vanadium played an important part in the alloy design concept, but for simplicity, our discussion will be limited to the combination of W and Mo in the W_{eq} concept. Table I shows the various grades which make up the T series. Beginning with the grandfather of high speed steel, T1, which contains 18W-4Cr-1V and proceeding down the list to T15, it can be noted that 20% W represents the upper limit of W_{eq} which is contained in these alloys. Experience has shown that this W_{eq} level is the maximum which can be produced by conventional ingot practice to obtain a sufficient yield to allow the grade to be marketed profitably. Table II shows the various compositions which comprise the M series. Although there are many more grades in the M series than in the T series, we again note that the maximum tungsten equivalency contained in these grades is still only at the 20.5% level present in M33, M42 and M47.

Table I. Compositions of Tungsten-Type High Speed Steels

Type	<u>Weight Percent</u>						
	<u>C</u>	<u>W</u>	<u>Mo</u>	<u>Cr</u>	<u>V</u>	<u>Co</u>	<u>Weq.*</u>
T1	0.75	18.00	-	4.00	1.00	-	18
T2	0.80	18.00	-	4.00	2.00	-	18
T4	0.75	18.00	-	4.00	1.00	5.00	18
T5	0.80	18.00	-	4.00	2.00	8.00	18
T6	0.80	20.00	-	4.50	1.50	12.00	20
T7 ⁺	0.75	14.00	-	4.00	2.00	-	14
T8	0.75	14.00	-	4.00	2.00	5.00	14
T9 ⁺	1.20	18.00	-	4.00	4.00	-	18
T15	1.50	12.00	-	4.00	5.00	5.00	12

Table II. Compositions of Molybdenum-Type High Speed Steels

Type	<u>Weight Percent</u>						
	<u>C</u>	<u>W</u>	<u>Mo</u>	<u>Cr</u>	<u>V</u>	<u>Co</u>	<u>Weq.*</u>
M1	0.80	1.50	8.00	4.00	1.00	-	17.5
M2	0.85;1.00	6.00	5.00	4.00	2.00	-	16
M3 Class 1	1.05	6.00	5.00	4.00	2.40	-	16
M3 Class 2	1.20	6.00	5.00	4.00	3.00	-	16
M4	1.30	5.50	4.50	4.00	4.00	-	14.5
M6	0.80	4.00	5.00	4.00	1.50	12.00	14
M7	1.00	1.75	8.75	4.00	2.00	-	19.25
M10	0.85;1.00	-	8.00	4.00	2.00	-	16
M15 ⁺	1.50	6.50	3.50	4.00	5.00	5.00	13.5
M30	0.80	2.00	8.00	4.00	1.25	5.00	18
M33	0.90	1.50	9.50	4.00	1.15	8.00	20.5
M34	0.90	2.00	8.00	4.00	2.00	8.00	18
M35 ⁺	0.80	6.00	5.00	4.00	2.00	5.00	16
M36	0.80	6.00	5.00	4.00	2.00	8.00	16
M41	1.10	6.75	3.75	4.25	2.00	5.00	14.25
M42	1.10	1.50	9.50	3.75	1.15	8.00	20.5
M43	1.20	2.75	8.00	3.75	1.60	8.25	18.75
M44	1.15	5.25	6.25	4.25	2.25	12.00	17.75
M45 ⁺	1.25	8.00	5.00	4.25	1.60	5.50	18
M46	1.25	2.00	8.25	4.00	3.20	8.25	18.5
M47	1.10	1.50	9.50	3.75	1.25	5.00	20.5

* Weq = Tungsten Equivalency, $Weq = \%W + 2(\%Mo)$.

+ AISI types formerly listed.

The most undesirable characteristic of conventionally produced high alloy tool steels is the high degree of alloy and carbide segregation which occurs during ingot solidification. This inherent segregation is not only detrimental to the hot workability and fabrication of these alloys, but also results in a reduction in mechanical properties and tool performance. An increase in the carbon and alloy content above the levels contained in the currently available tool steel grades results in an intensification of the segregation problem and an intolerably low product yield after hot working. The Crucible Particle Metallurgy or CPM process was developed to minimize alloy segregation in standard high alloy tool steel grades, but as mentioned above, a more significant feature of the CPM process is its use in the production of more highly alloyed grades than can be made by conventional practices. The resultant CPM product is hot worked on conventional mill facilities and the carbide size and distribution are controlled to develop optimized structures which offer significant performance advantages.

Two prominent cutting tool grades used in machining the very difficult-to-machine superalloys and titanium alloys used by the aircraft and aerospace industries are T15 and M42 which contain 5 and 8% cobalt respectively. Because of their importance in the machining of materials used in our national defense effort, development of Cobalt-free alternatives for these grades appeared highly desirable from both a strategic materials and a marketing standpoint. Before our alloy development program was initiated, the function of cobalt in high speed steels was considered to enable us to better define the alloy design concepts and property objectives which would have to be satisfied by a new alloy. Although the exact mechanism whereby cobalt enhances the

properties of HSS has not been explained completely, certain general property characteristics are normally attributed to the addition of 5 to 8% cobalt to HSS. In Roberts, Hamaker and Johnson's book, "Tool Steels,"⁶ some of the beneficial effects of cobalt in HSS are listed as follows:

1. Cobalt increases the solidus temperature thereby permitting the use of high austenitizing temperatures to achieve greater solutioning of alloying elements.
2. Cobalt enhances the secondary hardening reaction which results in a 1 to 2 HRC hardness advantage in the fully heat treated condition.
3. Cobalt enhances the hot hardness and temper resistance characteristics and thus allows a tool to retain a sharp cutting edge at higher machining speeds that generate heat.

Thus, the objectives of the initial phase of our alloy development program were to formulate a composition that would have room and elevated-temperature hardness as well as temper resistance characteristics equal to those of T15. If these objectives were successfully met, then impact and bend fracture strength, wear resistance and finally tool performance properties would be compared. Although, at this point, we realized that a cobalt-free HSS with these characteristics could only be produced by our CPM (particle metallurgy process) because of the anticipated necessity of increasing alloy content by a notable amount, small laboratory ingots of various compositions were made to expedite the hardening response and temper resistance studies. Basically, our approach concentrated on the substitution of higher tungsten equivalency levels for cobalt. One series of compositions began with a cobalt-free T15 composition for a base alloy and molybdenum was progressively added up to a tungsten equivalency level

of about 34%. Samples of CPM Rex T15 were also included in our studies to serve as a comparison base. The variation of heat treated hardness and 1200F temper resistance with tungsten equivalency is shown in Figure 3. The cobalt-free T15 analysis shows the predicted drop in attainable hardness and temper resistance; however, both attainable heat treated hardness and temper resistance showed a maximum value at a tungsten equivalency of about 25%; hence, our designation of CPM Rex 25 for the optimized composition of this alloy development program. Rex 25 heat treated hardness and temper resistance is comparable to that of CPM Rex T15. Further alloy development work was conducted on Rex 25 using CPM heats until the carbon and alloy contents were optimized. The final CPM Rex 25 composition is shown in Table III along with that of CPM Rex T15.

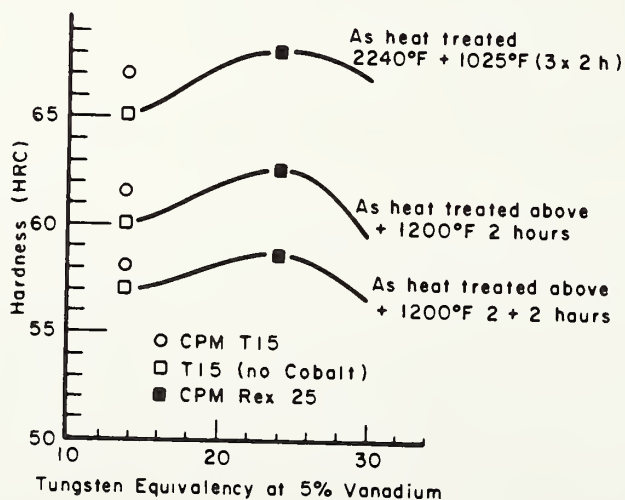

Figure 3 - Effect of Weq on Attainable Hardness and 1200F Temper Resistance of CPM Rex 25.

Table III. Compositions of CPM Rex 25 and CPM Rex T15

	Weight Percent					
	C	Cr	V	W	Mo	Co
CPM Rex 25	1.80	4.0	5.0	12.5	6.5	None
CPM Rex T15	1.55	4.0	5.0	12.25	None	5.0

CPM Rex 25 was produced at the Specialty Metals Division in Syracuse, NY, and processed to bar product to obtain material for laboratory property comparison with CPM Rex T15. The results of these comparisons are shown in the next four tables. Tables IV and V show the results of temper resistance and hot hardness comparisons for specimens which were heat treated to full hardness. These results show that CPM Rex 25 and CPM Rex T15 are equivalent in both temper resistance and hot hardness. Table VI shows the C-notch impact and bend fracture strength values obtained on CPM Rex 25 in three heat treated conditions, along with values obtained on CPM and conventional T15. Both the C-notch impact and the bend fracture strength of CPM Rex 25 are slightly lower than those of CPM T15, but are notably higher than those of conventional T15 and were considered acceptable for this alloy.

Table IV. Temper Resistance of CPM Rex 25 and CPM Rex T15.

	HARDNESS (HRC) AFTER INDICATED EXPOSURES				
	As Heat Treated (2250F, 1025F/3x2 hr)	Heat Treated + 1100F/2 hr		Heat Treated + 1200F/2 hr	
		1100F/2+2+4 hr	1100F/2+2+4 hr	1200F/2+2+4 hr	1200F/2+2+4 hr
CPM Rex 25	68	66.5	65.5	62.5	55
CPM Rex T15	67	65.5	64.5	61	54.5

Table V. Hot Hardness (HRC) of CPM Rex 25 and CPM Rex T15

	Room Temp. Before Test	Test Temperature			Room Temp. After Test
		1000F	1100F	1200F	
CPM Rex 25	67.8	57.8	54.0	48.4	64.3
CPM Rex T15	66.7	57.1	54.2	48.2	63.4

Table VI. C-Notch Impact and Bend Fracture Strengths of CPM Rex 25 and T15

Response to Heat Treatment and Properties -

	Aust. *	HRC	C-Notch Impact Strength (ft-lb)	Bend Fracture Strength (ksi)
	Temp. (F)			
CPM Rex 25	2250	68	9.5	531
CPM Rex 25	2200	66.5	12.5	623
CPM Rex 25	2150	66	11	627
CPM Rex T15	2250	67	14	678
Conv. T15	2250	66	4	312

* 4 minute soak in salt bath and oil quenched. Triple tempered at 1025F.

Because of the favorable laboratory test results obtained on CPM Rex 25, test material was supplied to about 30 toolmakers for use in tool tests involving 14 different types of tools. The tests which have been completed have shown CPM Rex 25 performance to be comparable or superior to that of conventional and CPM Rex T15. The highly favorable field test results along with a growing number of requests for bar stock resulted in the commercialization of Rex 25 in December, 1979. Results have been very encouraging and we are fully convinced that another cobalt supply interruption would not present a problem for the full replacement of T15 with CPM Rex 25.

Table VII. CPM Rex 25 Typical Field Test Results.

		<u>Tool Manufacturer</u>			Drill
Application:	Lab test drilling 1/2" holes in 1-1/4" thick 4340 at HRC 31/33.				
Results:		<u>1st Test</u>	<u>2nd Test</u>	<u>3rd Test</u>	
	CPM Rex M-	28	31	-	
	M42	17	23	-	
	CPM Rex 25	37	42	40	
		<u>Tool Manufacturer Laboratory Testing</u>			End Mills
Application:	Profile milling 4340 at BHN 285				
Results:	Inches milled:	130"			
	Wear land:				
		T-15:	0.011"		
		CPM Rex 25:	0.008"		
		<u>Test by an Aircraft Engine Manufacturer</u>			End Mills
Application:	Production milling A286 high temperature alloy with 1/2", 4 flute end mill.				
Results:	CPM Rex 25 tool life performance 200% better than M42.				

When the CPM Rex 25 development effort progressed to the point where laboratory properties obtained in the initial CPM experimental compositions were favorable, a development program was begun on a cobalt-free alternative for M42 using the same principles and procedures as those used in the Rex 25 program. As producers of both CPM and conventional M42, we knew that such a development would be even more significant than one which provided a cobalt-free alternative for T15 because the M42 market is notably greater than that for T15. Consequently, successful development of this grade would result in a substantial reduction in cobalt usage in HSS.

A simplistic view of our design concept for this program would be the addition of W to a 10%Mo-1%V base. Again, a series of small laboratory ingots were made to obtain material for a rapid assessment of the heat treatment response and temper resistance characteristics of various compositions. A cobalt-free version of M42 was included in our experimental alloy series and shows the anticipated cobalt effect. Throughout all of our studies, specimens of CPM Rex M42 were included to serve as a comparative base for the experimental alloys. Figure 4 shows the effect of Weq on the hardening response and temper resistance at 1200F.

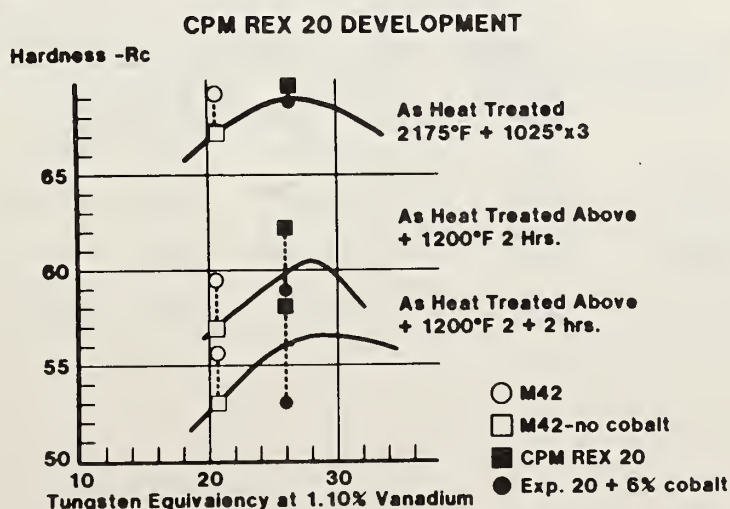

Figure 4 - Effect of Weq on Attainable Hardness and 1200F Temper Resistance of CPM Rex 20.

These results are similar to those obtained on Rex 25 except that the maximum hardness was obtained at a slightly higher Weq level. A maximum hardness and temper resistance was obtained which was equal or superior to that of CPM Rex M42. However, in our studies of the microstructures of CPM versions of the Exp. 20 (1.10V) compositions, we noted that the grain size of Exp. 20 was coarser than we normally find in CPM product. Therefore, CPM alloys with 2% V were produced and evaluated. The higher vanadium version showed the desired grain size refinement. As shown in Figure 4, the heat treatment response and temper resistance of the 2% V version was comparable or superior to that of M42.

To determine if it was possible to improve these properties, 6% cobalt was added to the Exp. 20 (1.10%V) base. It is interesting to note that properties were not improved and thus the cobalt effect has apparently been eliminated at this high Weq level. Additional compositions were evaluated in CPM form and the optimized CPM Rex 20 composition shown in Table VIII was selected.

Table VIII. Composition of CPM Rex 20 and CPM M42

	Weight Percent					
	<u>C</u>	<u>Cr</u>	<u>V</u>	<u>W</u>	<u>Mo</u>	<u>Co</u>
CPM Rex 20	1.30	3.75	2.00	6.25	10.50	None
CPM Rex M42	1.10	3.75	1.10	1.5	9.5	8.0
CPM Exp. 20	1.24	3.75	1.10	6.30	10.00	None

A production heat of the CPM Rex 20 composition was melted and rolled to bar to obtain material for property comparisons with CPM and conventional M42. Table IX shows the 1100 and 1200F temper resistance and Table X the hot hardness comparisons between CPM Rex 20 and M42. These results show that our objective to attain properties comparable to those of CPM Rex M42 has been fully satisfied.

Table IX. Temper Resistance of CPM Rex 20 and M42

Hardness (HRC) After Indicated Exposures

	As Heat Treated Hardness (HRC) 2175°/ 1025/3x2 hr.	1100F		1200F	
		2 hrs.	2+2 hrs.	2 hrs.	2+2 hrs.
CPM Rex 20	67.5	66	65.5	60.0	57.0
CPM Rex M42	67.5	65.5	65.0	59.0	55.5
Conv. M42	67.5	65.0	65.0	59.0	55.0

Table X. Hot Hardness of CPM Rex 20 and M42

Hot Hardness (HRC) at Indicated Temperature

	Room Temp. Before Test	Test Temperature			Room Temp. After Test
		1000F	1100F	1200F	
CPM Rex 20	67.5	58.2	56.0	47.5	63.8
CPM Rex M42	67.0	58.4	56.0	48.0	63.0
Conv. M42	66.5	58.5	56.1	48.0	62.2

Table XI shows the Charpy C-notch impact and the bend fracture strength results. CPM Rex 20 and CPM Rex M42 were equal in both properties and both were notably superior to conventional M42. In addition, results are shown for the initial CPM Exp. 20 composition which contains 1.1% V. The beneficial effects of the higher vanadium content in the finalized CPM Rex 20 composition are obvious.

Table XI. C-Notch Impact and Bend Fracture Strengths of CPM Rex 20, M42 and Exp. 20

Response to Heat Treatment and Properties

	<u>Aust.* Temp.°F</u>	<u>HRC</u>	<u>C-Notch Impact Strength (ft-lb)</u>	<u>Bend Fracture Strength (ksi)</u>
CPM Rex 20	2175	67.5	12	581
CPM Rex M42	2175	67.5	12	581
Conv. M42	2175	67.5	5	372
CPM Exp. 20	2175	67.5	9	426

*1 minute soak in bath and oil quenched. Triple tempered at 1025F.

As a result of these favorable laboratory test results, CPM Rex 20 test material was provided to various toolmakers for performance valuations. These field cutting tool tests were very successful in that CPM Rex 20 provided equal or superior performance to M42.

Table XII: CPM Rex 20 Typical Field Test Results

Tool Manufacturer Laboratory Testing

Application: End milling D2 tool steel, annealed
1/2" diameter, 4 flute end mills

Results:	<u>Length of Cut to .010" Wear Land</u>
CPM Rex 20	325 inches
Conventional M42	225 inches

Production Test by Form Tool User

Application: Turning AISI S5 Tool Steel
3" diameter circular form tool

Results:	<u>Parts/Hour</u>	<u>Parts/Tool Grind</u>
CPM Rex 20	30	200
Conventional M43	30	100

Tool Manufacturer Laboratory Testing

Application: Drilling AISI 4150, 1/2" thick at Rc 33 hardness
1/4" drills

Results:	<u>Average Holes Drilled</u>
CPM Rex 20	155
Conventional M42	84

The highly favorable field test results along with a growing number of requests for bar stock resulted in the commercialization of CPM Rex 20 in March, 1981.

Results have been very encouraging and we feel that another cobalt supply interruption or increased cost would not present a problem in the replacement of M42 and other cobalt-containing high speed steels with cobalt-free Rex 20 or Rex 25.

The Crucible Particle Metallurgy process has made it possible to develop a new metallurgical principle on which a U.S. patent number has been issued. This new alloying concept has led to the commercial development of two cobalt-free super high speeds - CPM Rex 25 and Rex 20. The new grades are equivalent or comparable to their cobalt-bearing counterparts in the following properties:

1. Hardening response and attainable hardness.
2. Temper resistance.
3. Hot hardness.
4. Charpy C-notch impact strength.
5. Bend fracture.
6. Field cutting tool performance test.

REFERENCES

1. W. T. Haswell, Jr., W. Stasko, and F. R. Dax, "Cobalt-Free CPM High Speed Steels," The Metallurgical Society of AIME paper, 1980.
2. E. J. Dulis and T. A. Neumeyer, "Particle-Metallurgy of High-Speed Tool Steel," pp 112-118 in Materials for Metal Cutting, The Iron and Steel Institute, London, Publication 126, 1970.
3. A. Kasak and E. J. Dulis, "Powder-Metallurgy Tool Steels," Powder Metallurgy, 21 (2) (1978) pp 114-123.
4. A. Kasak, G. Steven and T. A. Neumeyer, "High-Speed Tool Steels by Particle Metallurgy," SAE Paper 720182, 1972, pp 2-5.
5. John T. Berry, "High Performance High Hardness High Speed Steels," Climax Molybdenum Company, Greenwich, CT. 1970.
6. G. A. Roberts, J. C. Hamaker, Jr. and A. R. Johnson, "Tool Steels," pp 710-713, American Society for Metals, Metals Park, Ohio, 1962.

The material contained in this paper is intended for general information only and should not be used in relation to any specific application without independent study and determination of its applicability and suitability for the intended application. Anyone making use of this material or relying thereon assumes all risk and liability arising therefrom.

W. T. Haswell
6/3/81

SUBSTITUTION FOR COBALT IN MAGNETIC ALLOYS

Thomas D. Schlabbach
Bell Telephone Laboratories

Substitution for Cobalt in Magnetic Alloys

by

T. D. Schlabach
Bell Telephone Laboratories
Murray Hill, New Jersey 07974

The magnetics industry has been more successful perhaps than any other in reducing its dependence on cobalt through the use of substitutes that contain less or even no cobalt. This is reflected in the fact that cobalt demand in this area fell from nearly 25% of all cobalt demand in 1977 to 15% in 1980 according to U.S. Bu Mines data. Since most of the magnetic use of cobalt is in Alnico V, the solution to our cobalt usage problem lay principally in finding substitutes for this alloy and, happily, several were available. Beyond the permanent magnet alloys represented by the Alnicos, however, cobalt finds wide use in other magnetically soft and semi-hard alloys for which substitutes were also desired and were less obvious. Nonetheless, several promising substitutes have been found in these categories that contain no cobalt, are easier to process and that offer substantial cost reductions with little or no sacrifice in performance.

1. Cobalt Substitution in Permanent Magnets

For many loudspeaker and magneto applications, particularly in consumer markets, product redesign to use cobalt-free hard ferrites ($\text{BaO} \cdot 6\text{Fe}_2\text{O}_3$) was possible and done. Other possibilities for special use included cobalt rare-earth magnets and Mn-Al-C, though the latter is not available commercially (1). Other promising permanent magnet alloys include the low-cobalt Chromindur alloys, the Fe-Mn and the Fe-Mo-Ni alloys shown in Table I that were developed at Bell Laboratories for telecommunications use. Their use in these applications provides a convenient means for discussing their properties and processing.

2. Magnetic Alloy Substitution in Telephone Receivers

Telephone receivers account for the largest single use of magnetic alloys and cobalt in the Bell System and the current ring-armature receiver used is shown schematically in Figure 1. Until recently, the permanent magnet in this design was Remalloy (Fe-20Mo-12Co) but developments started in 1975 led to its replacement by the Fe-28Cr-10.5Co alloy known as Chromindur II. These Chromindur alloys, like Alnicos, transform spinodally but, unlike Alnicos, are ductile. They can be processed to exhibit anisotropic magnetic

properties by magnetic field aging, as is done with Alnicos, or, more conveniently, by deformation aging. The latter processing in the Fe-33Cr-11.5Co alloy, known as Chromindur III, leads to a maximum energy product (BH_{max}), which exceeds that of Alnico V at less than half its cobalt content.

In general, the Chromindurs offer magnetic properties equivalent to the Alnicos at a third to a half their cobalt content while combining good ductility and ease of processing with low cost.

Another important magnetic part of the receiver is the ring armature currently made from 2V-Permendur having the composition and properties shown in Table III. To perform properly, the armature must have a high maximum permeability (μ_{max}), low coercive force (H_c) and good elastic properties. The ability to substitute the Fe-6-12Ni alloys for the 2V-Permendur in this application is due to the development of a two-phase, low-temperature heat treatment that markedly improves the soft magnetic properties of Fe-rich, Fe-Ni alloys. These Fe-Ni alloys are also much easier to process than 2V-Permendur and much cheaper (2).

3. Reed Switches

Next to station apparatus, telecommunication's most important use of cobalt-containing magnetic alloys is found in reed switches that contain externally actuated contact elements held in a sealed glass envelope. These remanent reed sealed contacts currently use either Type 27 Remendur or Nibcolloy as the reed element; both of which in Table II are seen to have high cobalt contents. When the Fe-8Mn or Fe-7Mo-5Ni alloys are processed to exhibit an extremely fine-grained, elongated and aligned, two-phase structure they can offer very high remanence (B_R), a desired range of coercivity and high squareness (B_R/B_S). These characteristics combined with good glass sealing and surface quality make these alloys very attractive replacements for the standard semi-hard magnetic alloys (3,4). These substitution possibilities are currently being explored.

4. PMT Memory

The permanent magnet twister (PMT) memory is a random-access, semi-permanent, nondestructive readout memory used in electronic switching systems. It stores information in the form of small Vicalloy permanent magnets whose properties are given in Table I. Like many other standard permanent magnet alloys, Vicalloy has a high cobalt content and is a candidate for substitution. As can be seen in Table I, both the Fe-16Mn and Fe-20Mo-5Ni provide equal or higher energy products in alloys that are easier to process, contain no cobalt and are much cheaper.

These alloys are in the same families as those described in Table II though processed in a different manner to obtain permanent magnet properties (3,4). Beyond memories, these new permanent magnet alloys are suitable for speedometers, hysteresis motors, flag displays and anti-theft tags for stores and libraries.

5. Summary

The foregoing shows that the magnetics industry has been able to respond quickly and effectively to the challenge posed by uncertainties in the availability and cost of cobalt. This has been made possible by our deep understanding of magnetics and sophisticated thermomechanical processing of alloys, and further developments to eliminate or reduce our use of cobalt in magnetic materials may be anticipated. On the other hand, the unique properties conferred on magnetic alloys by cobalt make its continued use assured at a reasonable level.

6. References

1. Chin, G. Y., et al., "Impact of Recent Cobalt Supply Situation on Magnetic Materials and Applications," IEEE Trans. Magn. MAG-15: 1685-91 (1979).
2. Jin, S., et al., "Ferritic Fe-Ni Alloys for Potential Substitution of 2V-Permendur in Telephone Receivers," Presented at Int'l. Magnetics Conf., Grenoble, France, May 13, 1980.
3. Jin, S., and Tiefel, T. H., "High Remanence Square-Loop Fe-Ni and Fe-Mn Magnetic Alloys" IEEE Trans. Magn. MAG-16: 1062-64 (1980).
4. Jin, S., and Tiefel, T. H., "New Ductile Fe-Mo-Ni Magnet Alloys" to be pub. J. Appl. Phys. March 1981.

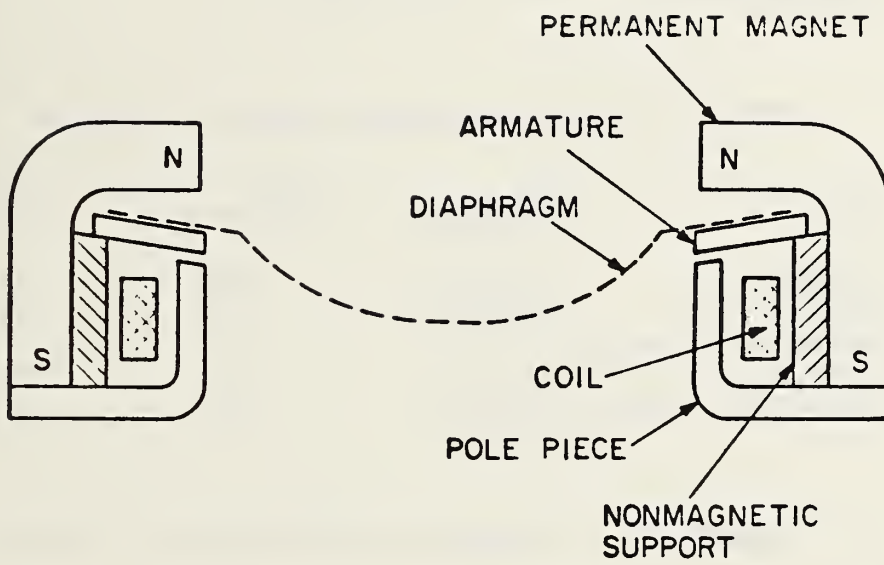

Fig. 1. Schematic illustration of the cross-sectional view of the U-type telephone receiver.

TABLE I. New Permanent Magnet Alloys

Alloy	B_R (Gauss)	H_C (Oersted)	$(BH)_{max}$ MG·Oe
Fe-28Cr-10.5Co	9,800	400	1.6
Fe-33Cr-11.5Co*	12,000	780	5.3-6.3
Fe-33Cr-7Co*	12,000	480	3.4-4.5
Alnico V (24Co)	12,000	720	5.0
Fe-16Mn	10,000	270	1.7
Fe-20Mo-5Ni*	10,500	210	1.1
Vicalloy I (52Co)	9,000	300	1.0

*Anisotropic

TABLE II. New Semi-hard Magnetic Alloys

Alloy	B_R (Gauss)	H_C (Oersted)	B_R/B_S
Fe-8Mn	18,000	28	0.96
Fe-7Mo-5Ni	19,200	30	0.97
Type 27 Remendur (49Co)	18,000	30	0.90
Nibcolloy (85Co)	15,000	20	0.95

TABLE III. Improved Soft Magnetic Alloys

Alloy	μ_{max}	H_C (Oersted)	B_{30} (Gauss)	ρ ($\mu\Omega$ -cm)
Fe-6~12Ni	2,000	1.2	17	20
	~6,000	~2.7	17	25
2V-Permendur (49Co)	4,500	2.0	20	26

BORONIZING AS A SUBSTITUTE FOR COBALT BEARING ALLOYS

Stanley R. Scales
Hughes Tool Co.

BORONIZING AS A SUBSTITUTE FOR COBALT BEARING ALLOYS

BY

STANLEY R. SCALES

HUGHES TOOL COMPANY

I. INTRODUCTION:

ROTARY DRILLING CURRENTLY IS THE STANDARD PROCEDURE FOR MAKING HOLES IN THE EARTH'S CRUST. ROTARY DRILLING IS USED FOR OIL, GAS, AND WATER WELLS, FOR BLAST HOLES IN THE MINING INDUSTRY, AND FOR HOLES MADE FOR OTHER PURPOSES. CONTRIBUTING SIGNIFICANTLY TO THE SUCCESS OF ROTARY DRILLING HAS BEEN USE OF ROLLING CONICAL CUTTER ROCK BITS. FIGURE 1 IS A BOTTOM VIEW OF A SOFT FORMATION ROCK BIT WITH THREE CONES HAVING HARDFACED STEEL TEETH. THE CONES ARE ALSO CARBURIZED, HARDENED, AND TEMPERED. THE RING GAUGE IN THE FIGURE SHOWS HOW WELL THREE CONES FILL THE HOLE BEING DRILLED AND PROVIDE THE MAXIMUM AMOUNT OF RELATIVELY LARGE TEETH AND BEARING CAPACITY.

FOR MANY YEARS, ANTI-FRICTION ROLLER BEARINGS, AS SHOWN IN FIGURE 2, HAD ADEQUATE LIFE FOR ROCK BITS WITH STEEL TOOTH CONES. IN 1951, THE FIRST ROLLING CONE ROCK BITS WITH CEMENTED TUNGSTEN CARBIDE TEETH WERE MARKETED. FOR SUCH BITS, THE TEETH WERE CYLINDERS WITH HEMISPHERICAL CUTTING END, AS SHOWN IN FIGURE 3. THE CYLINDRICAL PORTION OF EACH TUNGSTEN CARBIDE TOOTH IS PRESSED INTO A DRILLED AND REAMED HOLE IN A NON-CARBURIZED LOCATION. ANTI-FRICTION ROLLER BEARINGS USUALLY ARE NOT ADEQUATE FOR THE LONGER WEAR LIFE OF TUNGSTEN CARBIDE TEETH. JOURNAL BEARING, TUNGSTEN CARBIDE TOOTH BITS, AS SHOWN IN FIGURE 4, WERE INTRODUCED TO THE DRILLING INDUSTRY IN 1970-72, FOR THE FIRST TIME GIVING THE OILFIELDS A BEARING THAT LASTED AS LONG AS THE CARBIDE TEETH. THE CONES FOR SUCH BITS WERE INLAID WITH A SOFT, ANTI-GALLING, SILVER ALLOY IN THE GROOVES AND THE HOLES, AS SHOWN IN FIGURE 5, TO PROVIDE A SOLID FILM LUBRICANT.¹

THE BEARING PINS, AS SHOWN IN FIGURE 6, WERE HARDFACED WITH A COBALT BASE ALLOY, OXYACETYLENE TORCH APPLIED.

BECAUSE THE PERFORMANCE OF JOURNAL BEARING TYPE, CARBIDE TOOTH BITS WAS OUTSTANDING, INCREASED PRODUCTION WAS FORECAST AND HUGHES METALLURGISTS INITIATED WORK AIMED AT FINDING SUBSTITUTES FOR THE SILVER ALLOY AND THE COBALT BASE ALLOY. COPPER ALLOY, GTAW APPLIED, HAS REPLACED SILVER ALLOY IN MOST CONES OF THIS TYPE WITH SLIGHTLY IMPROVED PERFORMANCE; AND BITS WITH BORONIZED BEARING PINS HAVE REPLACED SOME THAT PREVIOUSLY USED COBALT BASE ALLOY HARDFACED BEARING PINS.²

II. BORONIZING OF BEARING PINS:

THE RESULTS OF LABORATORY BEARING MACHINE TESTS AND SURFACE TREATMENT TESTS REVEALED THAT:

1. A CARBURIZED AND BORONIZED STEEL JOURNAL SURFACE ON A BEARING PIN, IF PROCESSED SO AS TO HAVE A SMOOTH SURFACE AND TO HAVE THE CARBURIZED CASE CONVERTED TO TEMPERED MARTENSITE, PERFORMS SUPERIOR TO A SMOOTH HARD ALLOY JOURNAL SURFACE.^{3,4}
2. A CARBURIZED STEEL SURFACE CAN BE COMPOUND BORONIZED IN A MANNER SIMILAR TO COMPOUND CARBURIZING. FIGURE 7 SHOWS THE RESULTS OF TESTS USED TO DETERMINE THE EFFECT OF TIME ON PACK BORONIZED CASE DEPTH AT THREE DIFFERENT TEMPERATURES.

FOLLOWING ARE THE PATENTED STEPS THAT CAN BE USED TO PROVIDE THE BEARING PIN OF A ROCK BIT LEG (HEAD SECTION) WITH A CARBURIZED AND BORONIZED JOURNAL SURFACE, TYPICAL MATERIAL BEING SAE EX30 STEEL:

1. COPPER PLATE THE HEAD SECTION EXCEPT FOR THE MACHINED BEARING SURFACES OF THE BEARING PIN. THE COPPER PLATE PREVENTS CARBURIZATION OF NON-BEARING SURFACES.
2. GAS CARBURIZE THE BEARING SURFACES OF THE HEAD SECTION BEARING PIN.
3. GRIND OR OTHERWISE POLISH THE CARBURIZED BEARING SURFACES AS NECESSARY TO ASSURE THE DESIRED FINAL FINISH.
4. CUP PACK BORONIZE THE BEARING PIN FOR ABOUT 0.005IN.(0.13MM) BORONIZED CASE DEPTH USING A MIXTURE OF POWDERED BORON CARBIDE AND POWDERED GRAPHITE, WITH AN ENERGIZER ADDED. SEE FIGURES 8 AND 9.
5. UNPACK AND CLEAN THE HEAD SECTION, THEN QUENCH HARDEN AND TEMPER IT. FIGURE 10 SHOWS A FINISHED BORONIZED HEAD SECTION READY FOR ASSEMBLY.

THE MICROSTRUCTURE OF THE JOURNAL SURFACE OF THE BEARING PIN OF A HEAD SECTION SO PROCESSED IS SHOWN IN FIGURE 11. THE EXTREMELY HARD BORONIZED CASE IS SUPPORTED BY A HARD, STRONG, TOUGH HEAT TREATED CARBURIZED CASE.

KNOOP MICROHARDNESS MEASUREMENTS (100G LOAD) ON THE BORIDE PHASES SHOW THE PRIMARY Fe_2B PHASE TO BE 1550-1900 KHN AND THE TWO PHASE BORO-CARBIDE ZONE TO BE 1150-1450 KHN. IN CONTRAST, THE CARBURIZED CASE OF STEEL AT 60 HRC HAS A MICROHARDNESS OF APPROXIMATELY 730 KHN.

III. PERFORMANCE:

A JOURNAL BEARING TEST HAS BEEN IN USE IN OUR LABORATORY FOR A NUMBER OF YEARS TO MEASURE THE GALLING RESISTANCE OF MATERIAL PAIRS IN A LUBRICATED ENVIRONMENT. IN THIS TEST, A BUSHING OF HARDENED AISI 4815 STEEL ROTATES ON A SHAFT MADE FROM HARDENED SAE EX30 STEEL. THE DIAMETER AND CONTACT LENGTH OF THE SHAFT ARE SIMILAR IN DIMENSIONS TO THE JOURNAL BEARING OF A 7-7/8 IN. (200MM) DIAMETER ROCK BIT. THE INSIDE DIAMETER OF THE BUSHING IS CARBURIZED AND HARDENED (60 HRC) AND MAY HAVE SOFT METAL INLAYS. THE SHAFT SURFACE IS THE TEST MATERIAL UNDER CONSIDERATION.

TESTS ARE CONDUCTED WITH LUBRICATED SURFACES USING A PRESSURIZED LUBRICATION SYSTEM. LOADS AND RPM'S MAY BE ADJUSTED TO PRODUCE DIFFERENT PV (PRESSURE-VELOCITY) VALUES. AT A CONSTANT RPM SETTING, LOADS ARE INCREASED AT HOURLY INTERVALS WHILE MONITORING THE TORQUE NECESSARY TO ROTATE THE BUSHING. WHEN INITIAL SEIZURE (GALLING) STARTS, THERE IS AN INCREASE IN THE TORQUE OF THE SYSTEM. TESTS ARE CONDUCTED UNTIL CRITICAL SEIZURE (LOCKUP OF THE BUSHING AND SHAFT) OCCURS.

TABLE I SHOWS THE RESULTS OF PV TESTS CONDUCTED WITH SHAFTS (1) CARBURIZED AND HARDENED (60 HRC), (2) CARBURIZED, BORONIZED, AND HARDENED, AND (3) HARDFACED WITH A COBALT BASE ALLOY, STELLITE 190 (60 HRC). THESE RESULTS REPRESENT A LARGE NUMBER OF TESTS CONDUCTED OVER A PERIOD OF SEVERAL YEARS. THE CARBURIZED STEEL-CARBURIZED STEEL COMBINATION PRODUCES THE POOREST RESULTS. THE BORONIZED STEEL SHAFT EXHIBITS, WITH BOTH CARBURIZED AND INLAY TYPE BUSHINGS, SLIGHTLY BETTER PV RESULTS THAN STELLITE 190 RUN WITH A SILVER ALLOY INLAY BUSHING.

SUMMARY:

THE USE OF BORONIZING FOR THE BEARING SURFACES OF JOURNAL BEARING TYPE ROCK BIT HEAD SECTIONS HAS BEEN A SUCCESSFUL REPLACEMENT FOR COBALT BASE ALLOY APPLICATIONS.

FIGURE 12 SHOWS A BORONIZED HEAD SECTION AND A COPPER ALLOY INLAID, CARBIDE TOOTH CONE REMOVED FROM A ROCK BIT AFTER 111 HOURS OF SERVICE.

REFERENCES:

1. J. R. WHANGER, U. S. PATENT 3,235,316, FEB. 15, 1966.
2. H. C. DILL AND S. R. SCALES, METALLURGICAL DEVELOPMENTS AID BITS, TOOL JOINTS, OIL AND GAS JOURNAL (AUGUST 29, 1977).
3. S. R. SCALES, U. S. PATENT 3,922,038, NOV. 25, 1975.
4. S. R. SCALES, U. S. PATENT 4,012,238, MAR. 15, 1977.

TABLE I

PRESSURE-VELOCITY (PV) TESTS FOR JOURNAL BEARING SHAFTS

SHAFT BUSHING PAIR	PV AT INITIAL SEIZURE	
	PSI-FT/MIN	MPA-M/S
CARBURIZED STEEL - CARBURIZED STEEL	0.49×10^6	17.2
BORONIZED STEEL - CARBURIZED STEEL	0.76×10^6	26.6
BORONIZED STEEL - SILVER ALLOY INLAY	0.84×10^6	29.4
STELLITE 190* - SILVER ALLOY INLAY	0.58×10^6	20.3

ALL CONTACT SURFACES GROUND TO A ROUGHNESS OF 32×10^{-6} IN.
(8×10^{-4} MM) RMS OR BETTER.

*NOMINAL COMPOSITION:

3.37%C, 26%Cr, 0.8%Si, 14%W, 6%MAX.Fe, 1%MAX.Mo, 2%MAX.Ni,
1%MAX.Mn, BALANCE Co.

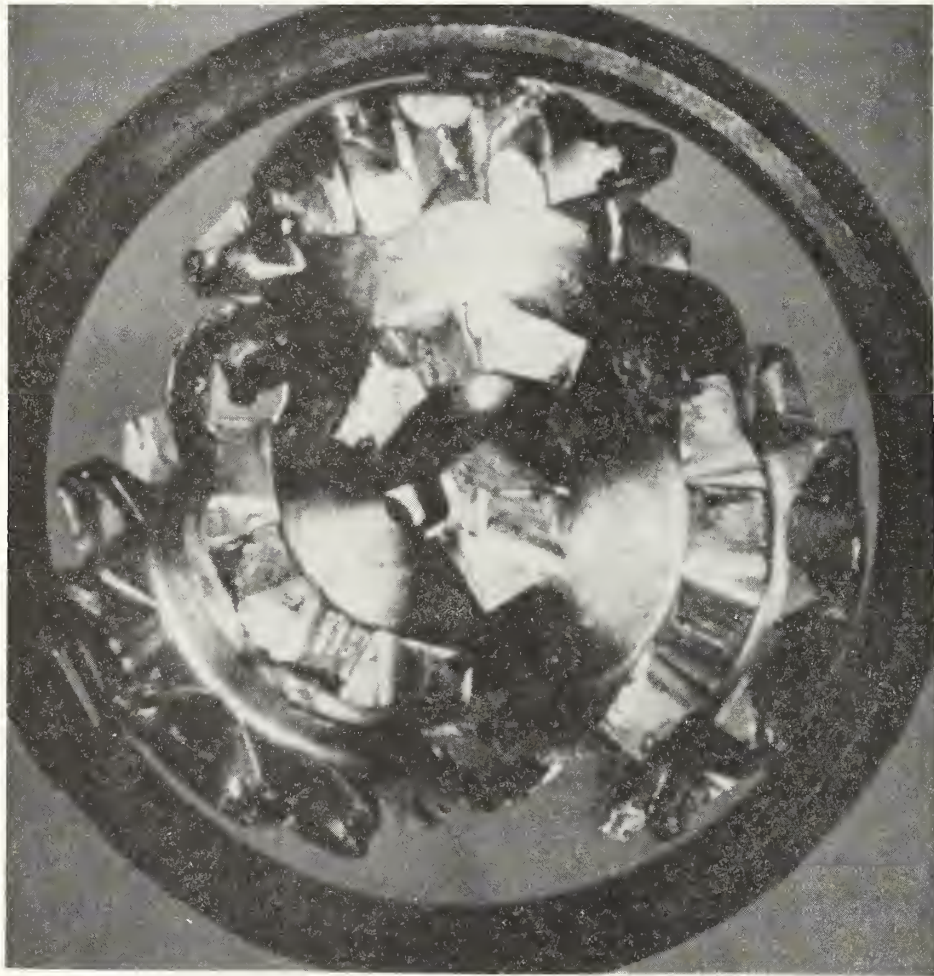

Figure 1

Bottom View Of Three-Cone, Soft Formation Rock Bit With Ring Gauge
To Show How Well Three Cones Fill The Hole Being Drilled.

Gauge Diameter 200 mm (7-7/8 in.)

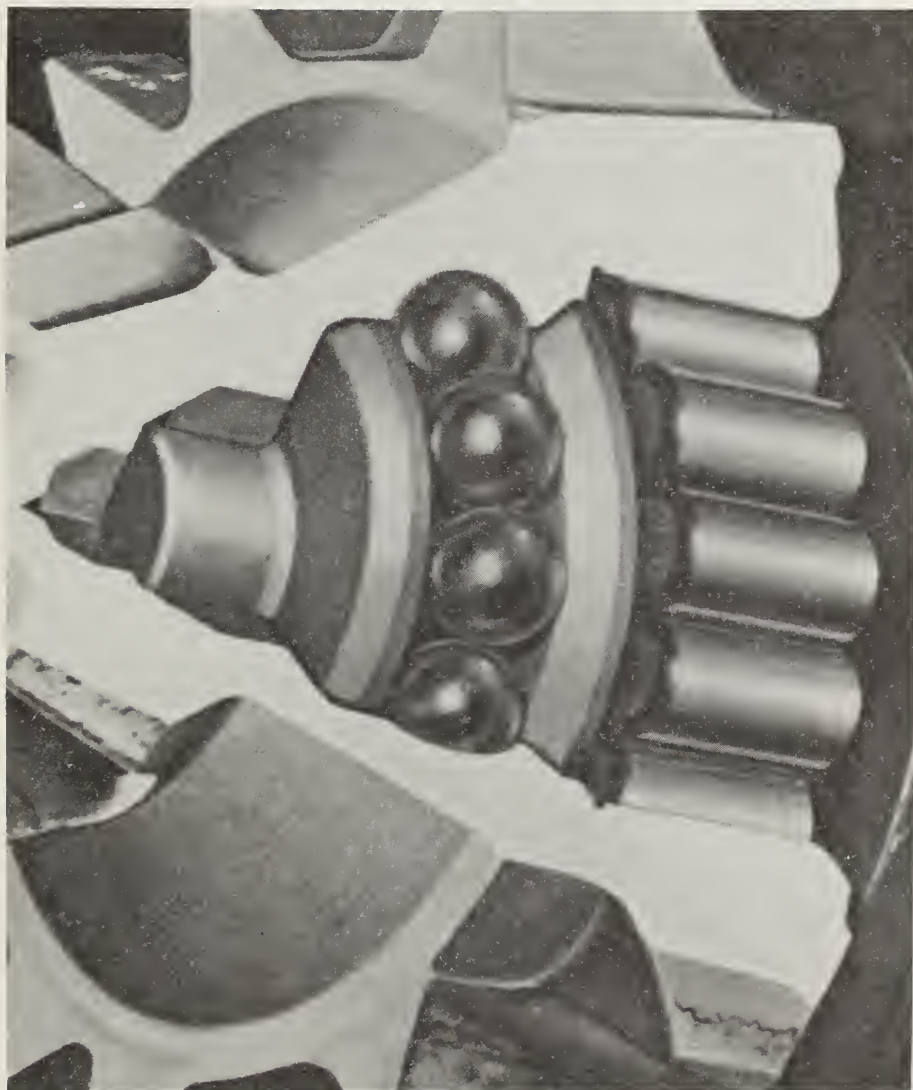

Figure 2

Typical Roller Bearing For Ball Bearing Retained Steel Tooth Rock Bit Cone



Figure 3

Tungsten Carbide Tooth, Hard Formation Bit Manufactured About 1960.

Note The Cemented Carbide Jet Nozzles Introduced In 1953.

Gauge Diameter 220 mm (8-3/4 in.)

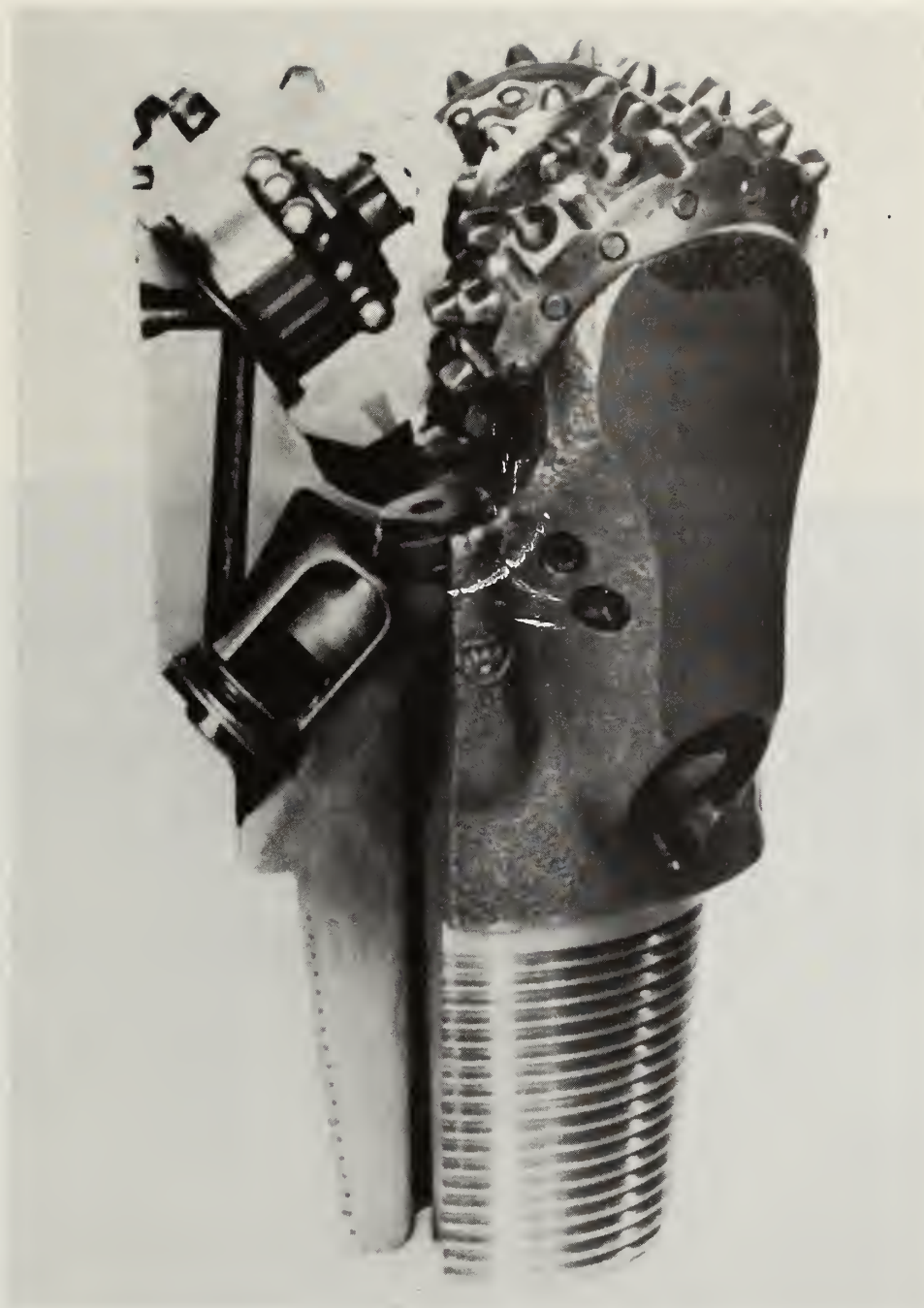

Figure 4

Tungsten Carbide Tooth, Medium Formation Bit Manufactured About 1972. One Bit Third Has Been Sectioned To Show Journal Bearing For Ball Retained Cone. Gauge Diameter 200mm (7-7/8 in.).



Figure 5

Tungsten Carbide Tooth, Journal Bearing Type Rock Bit Cone With Soft, Antigalling, Alloy Inlays In Bearing Surfaces.



Figure 6

Bearing Pin Portion Of Head Section Used For Tungsten Carbide Tooth, Journal Bearing Type Rock Bit Showing Cobalt Base Alloy Application On Bearing Surfaces.

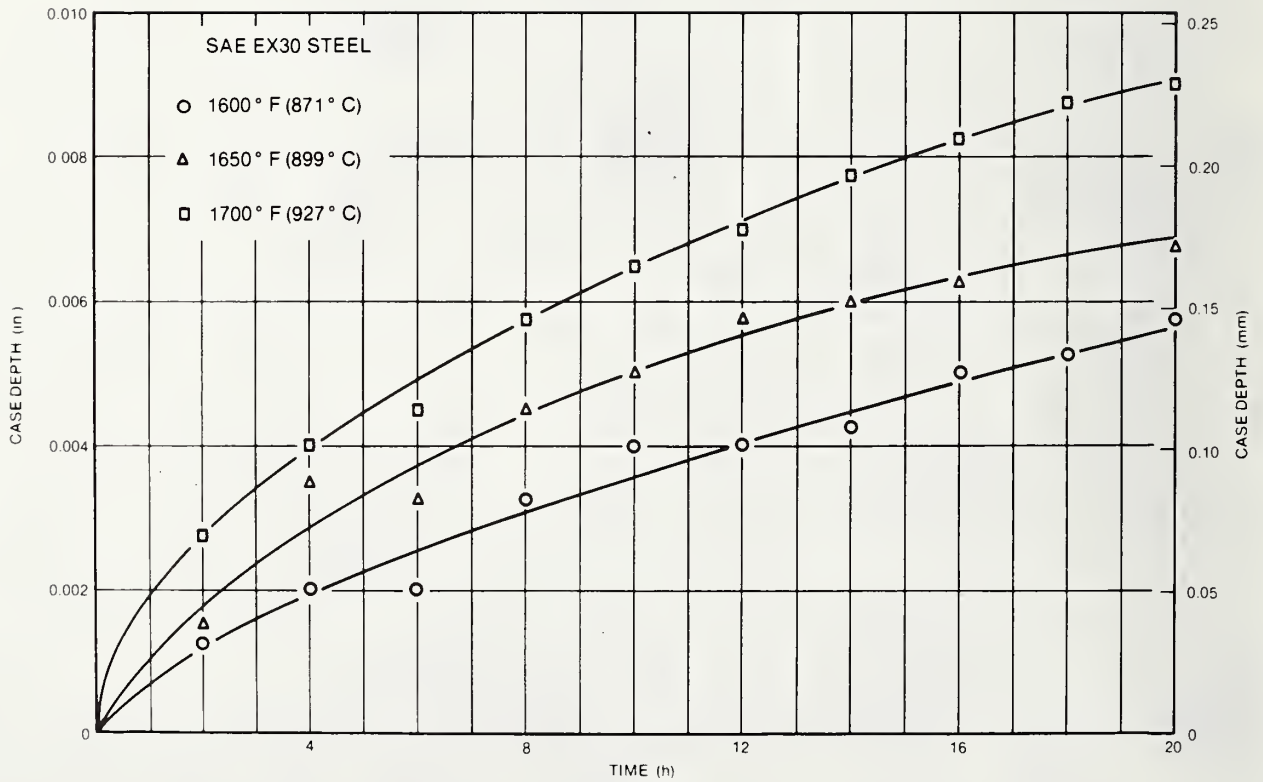

Figure 7

Boronized Case Depth As A Function Of Time And Temperature For Carburized SAE EX30 Steel.



Figure 9
Head Section Of Figure 1 With Cup Packed, Ready For Boronizing.

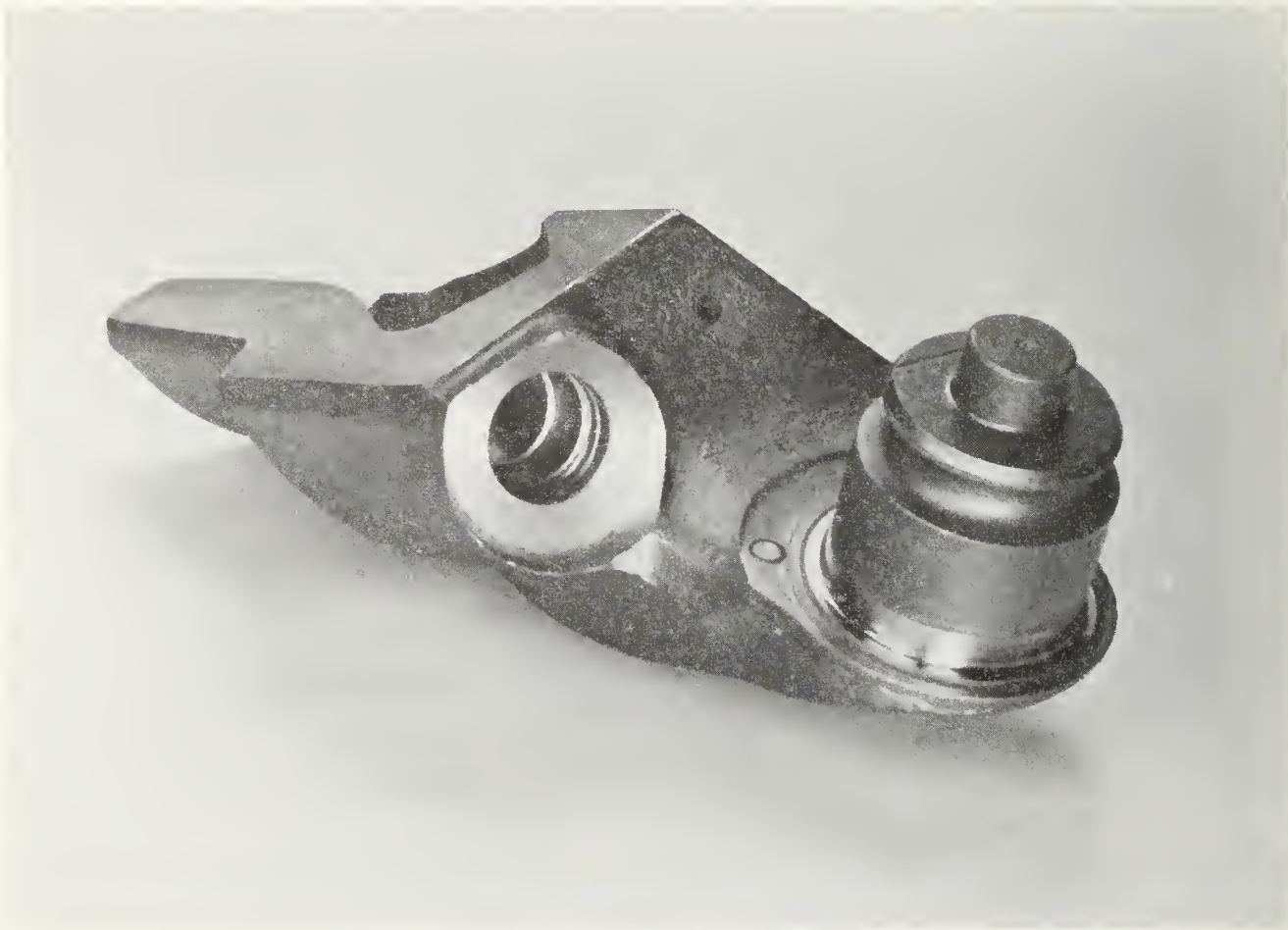

Figure 10

Head Section After Gas Carburizing, Pack Boronizing, Quenching, Tempering, And
Finish Machining.



Figure 11

Microstructure Of The Boronized Case On Carburized SAE EX30 Steel.

500X

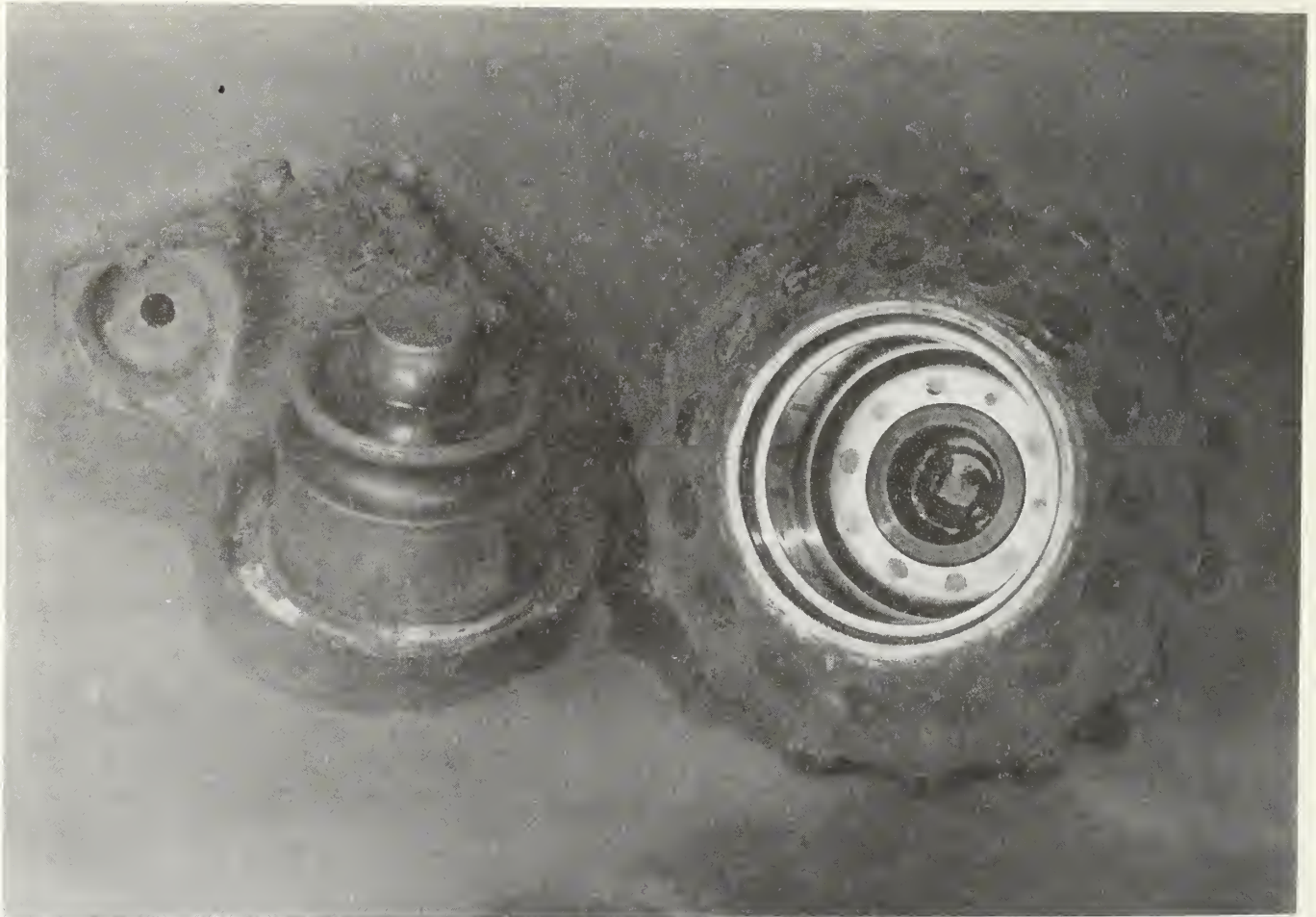

Figure 12

Head Section And Cone From "Hughes" J22 Bit Which Drilled 264 Meters (1201 Feet) Of Sand And Shale In 111 Hours At 20,250 Kg. (45,000 Pounds) Weight And 46 RPM. Cone Inlays Were GTAW Applied Copper Alloy. Bearing Pin Was Pack Boronized.

Gauge Diameter 251mm (9-7/8 in.)

P18-18

TECHNOLOGICAL OPPORTUNITIES FOR A MORE
STABLE SUPPLY OF TITANIUM

Harris M. Burte
Air Force Materials Laboratory

TECHNOLOGICAL OPPORTUNITIES FOR A MORE
STABLE SUPPLY OF TITANIUM

Harris M. Burte
Director Metals and Ceramics Division
AFWAL Materials Laboratory

The concern about disruptions or potential disruptions of the availability of titanium components in the United States is different than for most of the other materials being considered at this workshop. There is no shortage of titanium reserves in the world; it is an abundant material. Nor is there a shortage of titanium reserves in the United States. Although the raw material for producing titanium metal is now primarily imported, the amount of titanium tetrachloride produced from indigenous sources for conversion to titanium dioxide pigment far exceeds the amount of titanium tetrachloride which is converted into metal. Yet there is a concern about increases in the cost of titanium metal and long lead times for the procurement of some products such as forgings. There is fear that imbalances between supply and demand may continue to periodically reoccur. What is the problem?

Fluctuations in the world market - between different users and uses for titanium metal* and even potentially between metallurgical and pigment use are a normal part of a competitive system. This workshop is not intended to deal with these; rather it asks if there are problems unique or generic to the titanium industry where technological advances may help insure a more stable supply.

From its inception in the early 1950's, the growth of the titanium industry has had sharp ups and downs which have to now been tied to the fortunes and mix of products in the aerospace industry. As the need for jet engines grows or declines due to the overall needs of the military or commercial aircraft market so has the outlet for a considerable fraction of titanium production. As specific aircraft systems which use large amounts of titanium (in addition to the engine) go into production (such as the F14 or F15) or are cancelled (such as the SST or B1) periodic shortages or excesses of capacity may occur. The expansion of titanium usage in the non-aerospace market seems to have been relatively steady to the point where it has become a significant fraction of production, but here too the possibilities for the future introduce significant uncertainties. As the price of titanium components goes up will they maintain their hard won position in the chemical industry and in heat exchangers? Will major new uses evolve for energy production or conversion, or in new marine systems? How good are projections of future aerospace usage?

The inability to accurately forecast future demand may lead to recurring periods of over capacity or shortage in the future, as in the past. Is there

* "Titanium" as used here also refers to titanium base alloys.

one particular portion of the industry which is most sensitive to this situation? The "titanium" industry can be viewed as encompassing four major functions*:

- mining and conversion to a chemical precursor such as purified titanium tetrachloride.
- reduction to titanium metal.
- consolidation, e.g., arc melting to ingot.
- production of sheet, plate, tubing, forgings, etc. and conversion or assembly of these into finished products.

There seems to be general agreement that the first of these is not now, nor is likely to become the bottleneck to titanium metal production. Titanium tetrachloride incident to the production of pigment can be used for metal with little extra effort. Which of the next three is the source of which current shortages has been the subject of much controversy. At the precursor workshop to this one (1) all were advocated with some fervor by representatives of different segments of the industry. Minkler (2) suggests that from the viewpoints of capital intensity and construction lead time, and since they have utility for only one purpose, facilities for reducing tetrachloride to metal are and will be the key step. A panel of the National Materials Advisory Board is currently making an assessment of "US titanium production capability throughout the industrial complex from the source of raw materials to the finished mill products" (3). A generally accepted identification of current and potential future bottlenecks is obviously necessary and, although the stated purpose of this workshop is to address technological options, I have included the following question for the discussion period to see if consensus can now be reached:

"What aspect of titanium production - reduction, melting (consolidation), or mill shape fabrication (including forging) - is most likely to encounter future inadequacies which can result in significant shortages or price increases?"

From an overall viewpoint, will the "boom and bust" cycle continue, or will the shakeouts of the past lead to an industry which is inherently conservative and where new capacity tends to lag spurts in demand?

If history is any guide, and considering the uncertainties of use projections, periodic periods of shortage in titanium capacity is a reasonable future likelihood. There are two non-competitive approaches to try to ameliorate such a situation. In the first the Government can decide if it is in the national interest (e.g., for purposes of national defense) to modify the current marketplace and/or how it operates to provide the stability

*This categorization, although useful, does not fit all situations. Casting for example, can combine consolidation with production of components.

or risk indemnification that will allow supply capacity to stay equal to or above needs. For example, the initial growth of the titanium industry in the 1950's was due to Government encouraged financing, with loans and stock-pile purchase contracts (2). Under the current Defense Production Act, the Government can direct production towards specific uses or can provide incentives to creating additional capacity. Some have suggested direct "Government purchases and/or guaranteed prices for certain metals such as cobalt and titanium" (4). Additional options that are also currently mentioned include (5):

- replenishing the critical materials stockpile.
- modification of tax laws to remove disincentives to capital investment or to provide special incentives in selected areas.
- multi-year procurement for DoD programs.
- increased fully funded advance procurement for DoD programs.

The second approach considers the technological opportunities that exist or might be developed to cope with the situation, and the identification of those is the primary purpose of this workshop. They include the recognition and development of conservation and substitution options to permit a temporarily inadequate titanium production capacity to be optimally applied. From this point of view the options may be similar in nature (if different in detail) to those presented for many of the other materials being discussed here. They also, however, include opportunities which might lead to less capital intensive production processes, to lower cost titanium components and/or to expanded uses of titanium. The former might reduce the risk of establishing new titanium capacity against anticipated growth of need. The latter two by providing an expanded base for the industry reduce the impact of the ups and downs in the less predictable portion of the market, and also permit the most cost-effective uses to be more easily supplied during times of shortage.

The expanded use of titanium in the areas it has already penetrated - aerospace, heat exchanger tubing and chemical process equipment - will perhaps be paced in the next decade more by reduction in cost than by the development of higher performance alloys. In fact, if price escalation increases at its recent rate, titanium may lose many of its hard won markets. Titanium is also being considered or evaluated for a broad range of new applications (6). These include steam turbines, ocean thermal energy conversion, deep sea submersibles, geothermal energy and others. Successful penetration of such existing or potential markets may often require improved materials as well as low cost processes.

Just as the nature of the concern about titanium is different from that of many of the other materials being considered at the workshop, so will

the types of technological opportunities which exist. Thus the primary question I have posed for the discussion session is:

"What specific technological developments might lead to significant reductions in the cost of titanium components and/or expansion in its non-aerospace use"?

I will now try to provide an outline of the different types of technological development opportunities mentioned above and to illustrate with some examples of current or recent activity. I will indicate several papers in other sessions which should interact with or contribute to ours, and I will try to set a stage for our next two speakers. I will also offer a few personal opinions about promising directions for R & D to stimulate your response to the question posed above.

Substitution. Competition between materials or materials/design options has been characteristic of the rapid expansion of materials technology in the last several decades, and can be expected to continue (7). Titanium is no exception; its relative role will not necessarily remain static. If new competing materials replace it because they offer improved cost-effectiveness they will do so irrespective of periodic shortages. Other competing materials which involve some penalty will, in principal, come into use only during times of shortage or anticipated shortage. Selective use of such materials, for applications which involve the least penalty, could help mitigate the overall impact of shortages and the subsequent paper in this session on "Benefits of Titanium in Airframes and Compromises in Substitution" should provide additional insight into such options. In my opinion it would not be desirable to develop competing/substitute materials for titanium merely to hedge against periodic shortages; the goals should be to surpass titanium for specific uses and the efforts including expensive scale up and field evaluation should be justifiable on this basis. The materials which result would find specific uses on their own merits, and thus might be sufficiently developed for other less effective use (involving some penalties) in the event of titanium shortages. Some of the approaches which are now being or might be explored, which involve competition with present-day titanium technology, are:

- development of improved high temperature aluminum alloys using rapidly solidified powder and/or mechanical alloying approaches. (See the paper on "Potential for Rapid Solidification for Aluminum Alloys" in Session III B).
- development of high temperature advanced composites such as graphite filaments in processable polyimide matrices (see the papers in Session V).
- improved design and use of advanced composites for ambient temperature high load intensity applications.

development of high fracture toughness high strength steels for critical high load intensity applications.

It should of course be recognized that titanium technology need not sit still, and the goals of the above activities should take this into consideration. Further, the competing approaches may involve their own jeopardy to materials shortages or price increases which, in a specific case, may incur more risk than titanium.

Conservation. With titanium sponge approaching ten dollars a pound the economic impetus for conservation becomes evident. Further, if, as many have suggested, reduction (spongemaking) capacity is most likely to be the bottleneck in future shortages, conservation allows a limited supply to satisfy more usage. However, as in the case of substitutes, I do not believe that the development of conservation options can be justified solely as a hedge against possible periodic shortages. Rather the cost of the R&D and implementation of such options should be justified by the return on investment irrespective of shortage considerations. The range of application of the technology so developed can then be extended if shortages develop. Among the approaches, which have been or might be explored are:

- near net shape processing - isothermal forging (see the paper on "Potential for Near Net Shapes" in Session 111 B).
- progress is being made in developing casting processes (and post casting treatments) and defining attractive uses for the products; the long range potential of developing new, compatible alloy/mold material combinations should be reexplored.
- near net shape processing - powder metallurgy - recent work in my own laboratory (8) indicates that reliable properties can be attained by a combination of attention to cleanliness and control of the microstructure in the final component. The paper on "Advantages in Materials and Energy Utilization for Powder Metallurgy Titanium" in this session will explore this subject further (see also the paper on "Outlook for As-HIP'ed Near Net Shapes" in Session 111B).
- retirement for cause; the development of life prediction methods to predict the growth of cracks under actual use conditions, of reliable nondestructive inspection methods and of probabilistic decision models should permit the safe use of components (such as engine discs) well beyond the current practice of retiring an entire population at the lifetime when the first one will have an unacceptable risk of failure.
- variable property components; the development of a variety

of metallurgical synthesis methods will permit the production of "one horse shay" components such as compressor discs with dual microstructures to yield high fatigue strength at the hub and high yield strength at the rim (9).

- repair technologies.
- recycling; a closer evaluation of what impurity buildup or other contamination is permissible for what uses would permit more progress, as would the development of alloys/microstructures which are inherently more tolerant to some contamination (which may be inevitable).

Although several of the approaches above do involve a significant "conservation" aspect, they also contribute in other ways to cost reduction. In fact, these other aspects may be their more important justification, i.e., the reduction in machining cost for near net shape processes or the overall cost reduction possible if casting a complex shape can provide acceptable properties. Similarly, saving the overall manufacturing cost of most components is a more important aspect of "retirement for cause" than the value of the sponge or other materials contained in them.

Cost Reduction. The prime impediment to significant expansion in the use and range of applicability of titanium is cost, both the cost of sponge, and of mill forms and final products. The aerospace experience (10) is illustrative; initial performance driven designs of many aircraft often specify much more titanium than the final "cost affordable" product. Technological opportunities for significant cost reduction can thus play the key role in expanding the market for titanium and reducing the relative effect of inability to accurately predict need in certain portions of the market. In some cases such cost reductions may be necessary if existing applications are to be retained against the competitive pressure of evolving substitutes.

- Several of the approaches listed previously under Conservation have already been identified as important more for their overall cost reduction than for just the cost of the titanium saved. The potential of powder metallurgy or casting remains to be fully explored.
- The extractive metallurgy (including reduction) of titanium warrants considerably more long range/innovative R&D attention than it has received in the last two decades. Reducing the capital intensity and the energy cost of titanium are specific goals to be kept in mind (2). Reduction of titanium tetrachloride directly to usable powder, and of mixed chlorides or other precursors to alloy powders is a particularly intriguing approach. There have been hints in the literature, but I feel it has not received the attention it warrants. If attainable,

it might offer the hope of low cost, high quality input to the powder metallurgy fabrication approach discussed elsewhere (4).

- Are there approaches to producing large, high performance titanium components which do not require the large capital investment of heavy presses?
- Are there approaches for significantly reducing the cost of machining titanium?
- For aerospace applications significant effort has been expended and progress is being made (10). The development of approaches such as superplastic forming and diffusion bonding attempts to exploit certain metallurgical characteristics of titanium and to minimize the influence of others. Similar strategies should be continued, and perhaps exploited to a wider range of possible uses including the non-aerospace market.

Titanium metallurgy is an active field in which significant progress is being made. It offers many opportunities in addition to the few I have mentioned. For example, I believe that rapid solidification approaches (see Session III B), in particular, will open broad new vistas. I commend you all to a rededication of your energy, particularly to the longer range, more innovative possibilities which may emerge today or in your future thinking.

I hope that the outline given above, and the possibilities suggested will stimulate your input during the audience participation portion of the work shop which will follow.

REFERENCES

1. "Working Group on Critical Engineering Materials", Public Workshop on Critical Materials Needs of the Aerospace Industry, Feb 9-10, 1981.
2. W. M. Minkler, "Titanium in 1980", Journal of Metals, pp 41-44, April 1981.
3. NMAB Newsletter, Jan 1981.
4. Chemical and Engineering News, pg 20, May 11, 1981.
5. Testimony Before House Appropriations Committee, 13 Nov 1980.
6. D. Eylon (ed) "Titanium and Energy", TMS-AIME Publication, in press.
7. H. M. Burte, "The Nature of The Competition Between Emerging Materials" Materials and Society 2, pp 145-150 (1978).
8. D. Eylon & F. H. Froes "High Integrity Titanium Alloy Shapes by Powder Metallurgy", presented at Symposium on Titanium and Its Alloys for Surgical Implants.
9. H. M. Burte and H. L. Gegel in "Process Modeling - Fundamentals and Applications to Metals", pp 1-26, ASM Materials/Metalworking Technology Series (1980).
10. N. G. Tupper, J. K. Elbaum and H. M. Burte, "Opportunities for Cost-Affordable Titanium Aerospace Structures" Journal of Metals pp 7-13, Sept 1978.
11. F. H. Froes, D. Eylon, G. E. Eichelman, and H. M. Burte, "Developments in Titanium Powder Metallurgy", Journal of Metals, pp 47-54, Feb 1980.

ISOSTATIC PRESSING OF COMPLEX SHAPES
FROM TITANIUM AND TITANIUM ALLOYS

Stanley Abkowitz
Dynamet Technology Inc.

ISOSTATIC PRESSING OF COMPLEX SHAPES

FROM TITANIUM AND TITANIUM ALLOYS

Stanley Abkowitz
Dynamet Technology Inc.
Burlington, Massachusetts

The technology of cold isostatic pressing of powder metal into complex shapes with enhanced mechanical properties is discussed. The application of cold isostatic pressing, followed by vacuum sintering to produce complex titanium alloy shapes with properties equal to or exceeding those of castings in heavy to thin sections is demonstrated.

The significant economic and technical advantages of combining cold isostatic pressing (CIP) with hot isostatic pressing (HIP) to produce full density titanium alloy components are shown. The capabilities for production of complex powder metal shapes such as impellers, and the mechanical properties of these shapes achieved when manufactured from titanium powder and alloy powder additions are demonstrated. Both cost and energy saving advantages of the process are discussed.

Introduction

Cold isostatic pressing (CIP) of metal powders differs from conventional mechanical pressing in several ways that offer specific advantages.

- (1) Since hydrostatic (water-oil) pressure is applied uniformly on all surfaces of the part to be consolidated, the density achieved is of significantly greater uniformity.
- (2) With this uniform pressure the size of the part to be compacted is limited only by the dimensions of the pressure chamber.
- (3) Since the mold material is elastomeric (as opposed to punch and die hard tooling) no lubricant need be added to the powder to minimize galling and die wear.
- (4) With the elimination of lubricant no pre-sinter for lubricant removal is necessary and no contamination occurs.
- (5) With the use of elastomeric tooling, complex shapes beyond the capabilities of conventional pressing are feasible.

In the past, isostatic pressing was employed to compact ceramic materials at relatively low pressures and to form simple billets of difficult to melt metals such as tungsten and beryllium. More recently the technology has progressed to the manufacture of complex shapes from a variety of metals.

The greatest economic advantages of isostatic pressing lie in its application to metals that are relatively expensive and which are rather difficult to machine (since the process requires less input material and reduces the extent of machining required). Certainly one of the metals that fulfills these characteristics is titanium and its alloys.

As-Sintered Properties and Forging Preforms

Intensive developmental efforts of recent years (1) (2) have shown that titanium and its alloys could be cold compacted and vacuum sintered to achieve satisfactory density and useful mechanical properties. This was accomplished using inexpensive elemental powders in combination with master alloy powders as opposed to the more expensive pre-alloyed powders, which in addition to their high cost are not readily cold compactable.

The tensile properties achieved with commercially pure titanium and Ti-6Al-4V alloy are reviewed in Table I as follows:

TABLE I. MECHANICAL PROPERTIES OF AS-SINTERED
AND SINTERED PLUS FORGED TITANIUM

<u>C. P. Titanium (.12% Oxygen)</u>		
	<u>As-Sintered (94% dense)</u>	<u>Forged Preform (100% dense)</u>
UTS	62,000 psi (430 MPa)	66,000 psi (455 MPa)
YS	49,000 psi (340 MPa)	53,000 psi (365 MPa)
Elong.	15%	23%
R.A.	23%	30%
<u>Ti-6Al-4V (.12% Oxygen)</u>		
	<u>As-Sintered (94% Dense)</u>	<u>Forged Preform (100% dense)</u>
UTS	120,000 psi (830 MPa)	133,500 psi (920 MPa)
YS	107,000 psi (740 MPa)	122,000 psi (840 MPa)
Elong.	5.0%	11.0%
R.A.	8.0%	24.7%

The as-sintered properties represent a 94% of theoretical density product produced by isostatic pressing at 60,000 psi (415 MPa) followed by vacuum sintering at 2250°F (1232°C) for 3 hours. An improvement in properties is achieved by forging a 94% dense preform. The as-sintered tensile properties compare well with those properties achieved by conventional casting and offer an economic process for like applications. Where higher density and higher mechanical properties are required, forging the pre-shaped P/M preform may be employed. Other metal working techniques which have been proven to fully densify the as-sintered preform are rolling and extrusions. Typical forging preforms and a finished forged part are shown in Fig. 1 and Fig. 2.

By designing the elastomeric tooling in conjunction with a mandrel, cored shapes can be produced with configurations pressed and sintered close to size. The large titanium valve ball of Fig. 3 and the titanium alloy liner of Fig. 4 were produced by isostatic pressing around a mandrel which was removed from the cold pressed compact prior to vacuum sintering. The rotor cannister shown in Fig. 5 demonstrates the producibility of very thin walls (.035 inch/.90 mm). These parts are subsequently finish machined to final dimensions.

In the above applications the components possess the desirable mechanical properties and corrosion resistance in the as-sintered condition. It is interesting to point out that in addition to the considerable material and machining time saved by the preformed shape, further savings are offered in the finish machining operations which still must be performed. This is due to the improved machinability of the P/M material as indicated in Fig. 6. At 100 hole "tool life" the cutting speed for annealed Ti-6Al-4V improves from 25 feet per minute for the wrought product to 60 feet per minute for the P/M material (3).

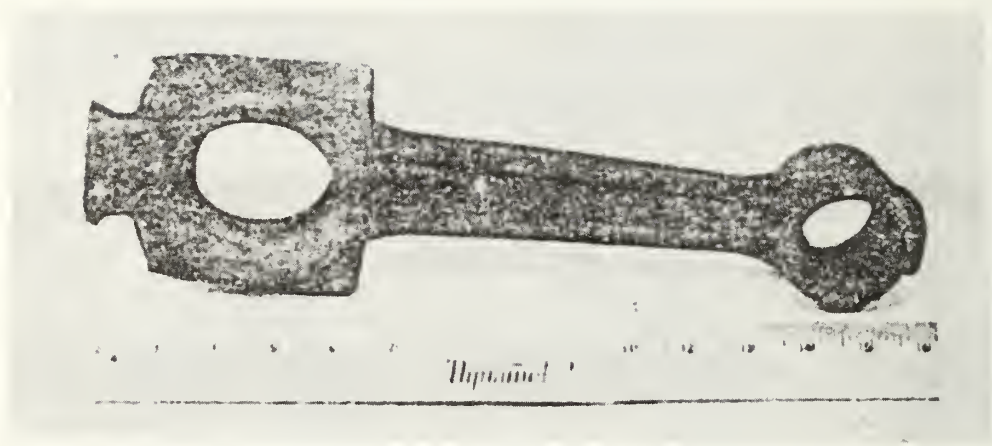
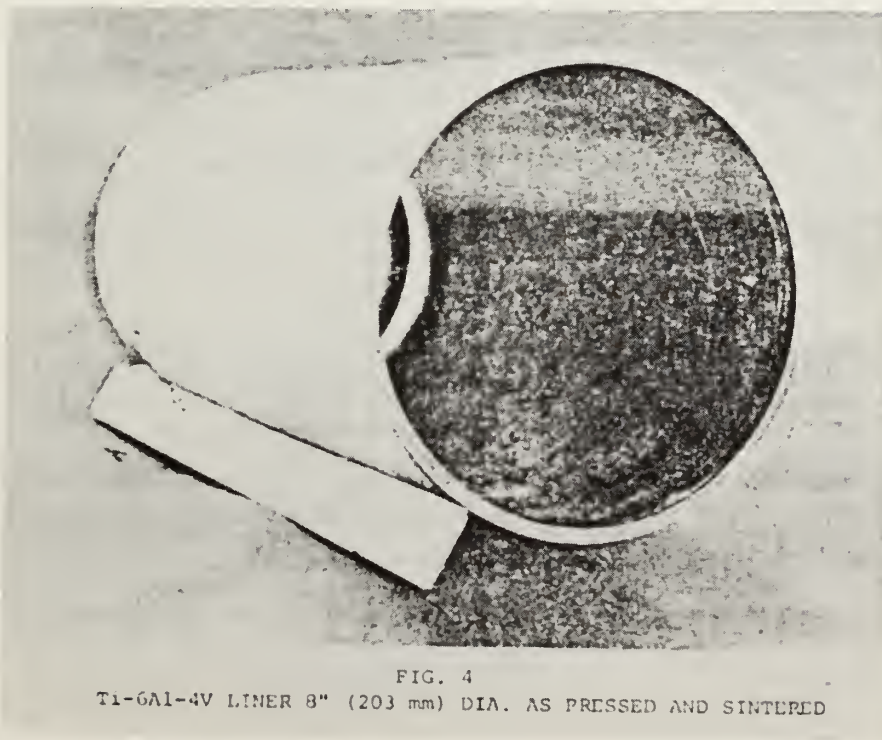
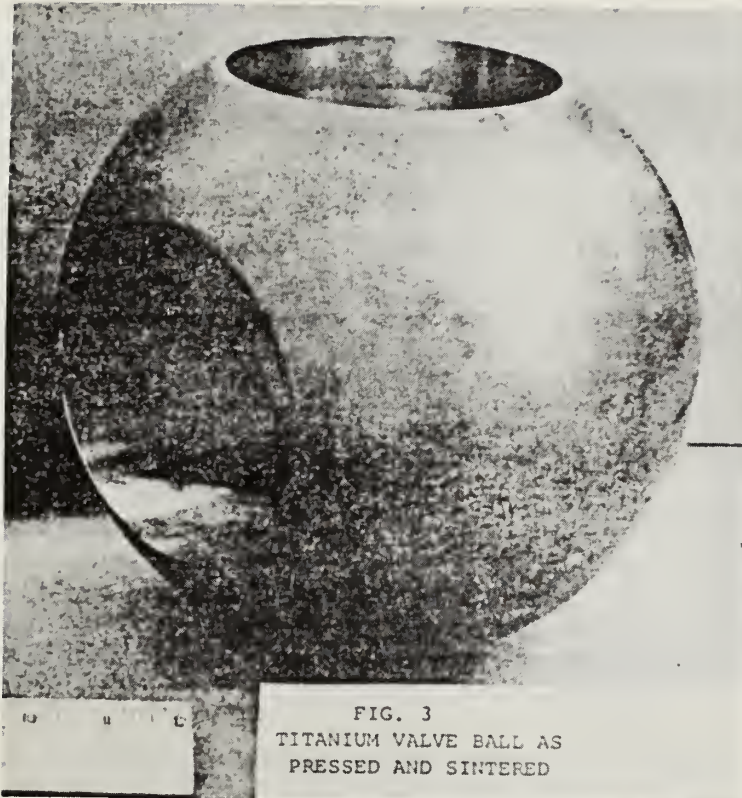

FIG. 1
TITANIUM ALLOY CONNECTING ROD AS PRESSED
AND SINTERED FORGING PREFORM



FIG 2
TITANIUM COMPRESSOR BLADE FORGING P/M Ti-6Al-4V PREFORM
AND FINISHED FULL DENSITY FORGING



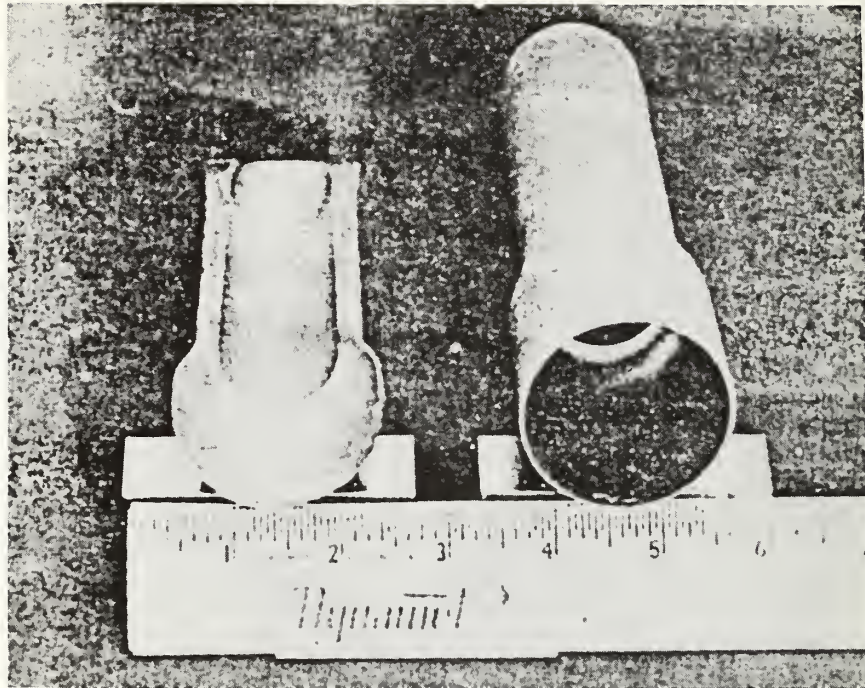

FIG. 5

Ti-6Al-4V ROTOR CANNISTER AS PRESSED AND SINTERED

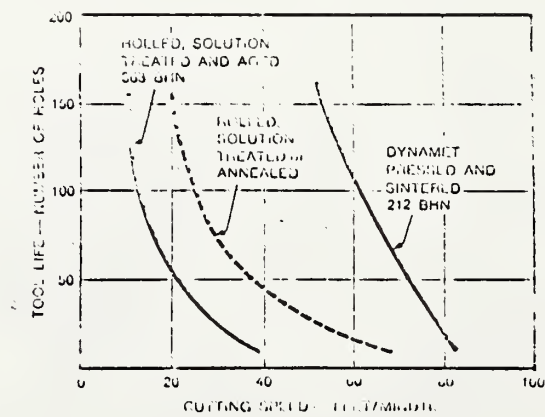

FIG. 6

MACHINABILITY STUDY ON P/H
TITANIUM 6AL-4V ALLOY

Subsequent Hot Pressing

For certain applications where full density is required, the hot working operations of forging, extrusion, or rolling can be performed on P/M preforms, but where deformation is not required, hot isostatic pressing (HIP) can be used to produce fully dense shapes (6). This is demonstrated by the microstructures of Figs. 7A and 7B which show the change in porosity of Ti-6Al-4V.

The chemical analysis and mechanical properties achieved after HIP are shown in Table II below and compare favorably with conventional 100% dense wrought product.

TABLE II. MECHANICAL PROPERTIES & CHEMICAL ANALYSIS
OF A Ti-6Al-4V SINTERED AND HIP PREFORM

<u>TENSILE TEST AT ROOM TEMP.:</u>		<u>CHEMICAL ANALYSIS:</u>	
Tensile P.S.I.	132,797 (916 MPa)	Iron	.085
Yield .2% offs.	120,024 (828 MPa)	Vanadium	4.07
Elongation in 4D	13.0%	Aluminum	5.97
Reduction Area	26.0%	Carbon	.035
		Hydrogen - Core	.0018
		Nitrogen	.0109
		Oxygen	.1978

This combination of cold isopressing, sintering and hot isostatic pressing is a highly economical technique for achieving maximum density, particularly for titanium alloys. The procedure is often referred to as CHIP. The prior cold isostatic pressing and sintering permits use of elemental master alloy powder which is significantly less expensive than pre-alloyed powder, as well as the use of elastomeric tooling during cold compaction to shape rather than expensive and expendable hard tooling used for canning pre-alloyed powders. In this manner, the sintered preform can be HIP as inexpensively as commercial titanium castings are currently densified. Rotating beam fatigue endurance limits at 10^7 of 52,000 psi (360 MPa) have been obtained with Ti-6Al-4V processed by this technique.

Complex Shapes

The technology of both CIP and CHIP processing permits significant advantages in the manufacture of complex shapes such as impellers. Figs. 8 and 9 show the detail that can be achieved in the complex configuration of a radial impeller. Cost savings in the manufacture of such shapes can be as high as 70% compared to conventional machining from billet or rough forging, even where subsequent machining might be required. Fig. 9 indicates the potential (with recent developments in tooling) for production of multi-holed structures and perforations in both thin and thick sections. The titanium alloy disc shown has over 1000 holes and is 3/16 inch (4.76 mm) thick. Heavier sections with square, triangular, or any shaped hole could readily have been incorporated into the tooling.

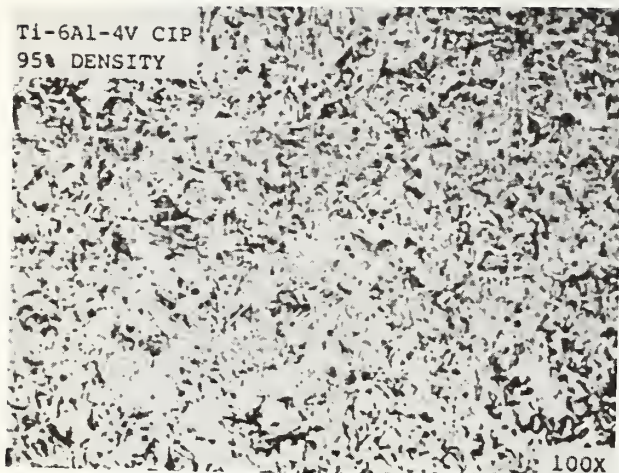

FIG. 7A
MICROSTRUCTURE Ti-6Al-4V
AS PRESSED AND SINTERED

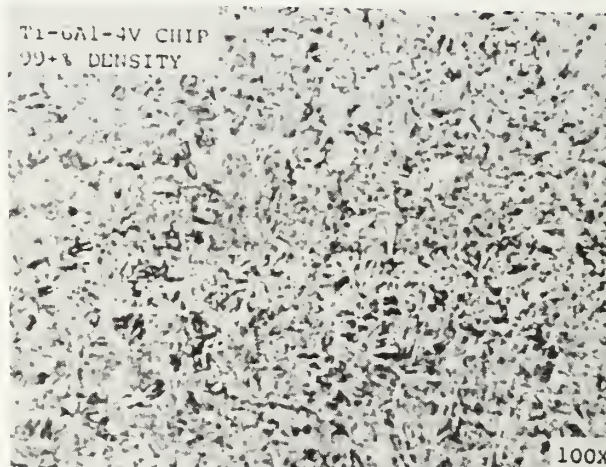

FIG. 7B
MICROSTRUCTURE Ti-6Al-4V
COLD ISOSTATIC PRESSED
AND SINTERED FOLLOWED
BY HIP



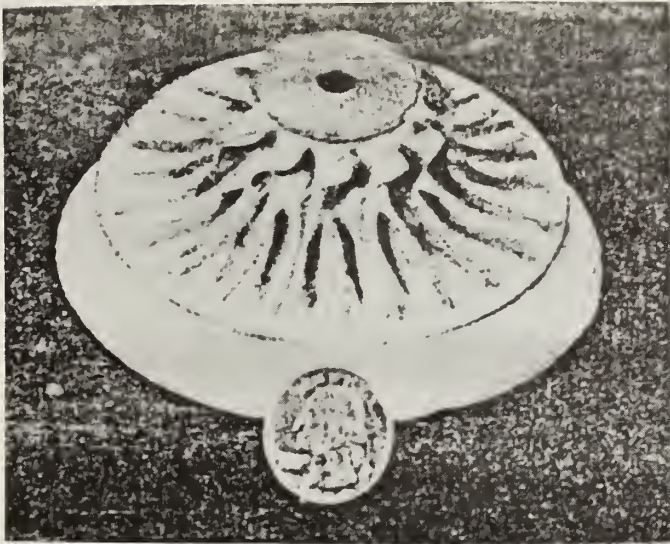

FIG. 8
Ti-6Al-4V
RADIAL ROTOR

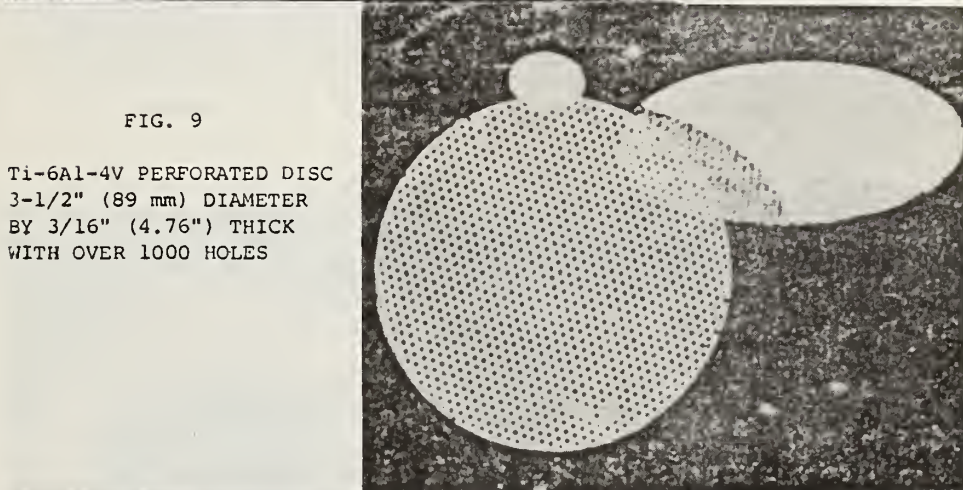

FIG. 9
Ti-6Al-4V PERFORATED DISC
3-1/2" (89 mm) DIAMETER
BY 3/16" (4.76") THICK
WITH OVER 1000 HOLES



FIG. 10
Ti-6Al-4V NOZZLE PREFORM AS ISOPRESSED AND AFTER VACUUM SINTERING

Cost and Energy Savings

Cost saving applications have emerged for isostatic pressing from industries as diverse as instant photography and missile manufacture. Fig. 10 illustrates a Polaroid titanium nozzle section where very expensive machining operations were previously employed. The use of isostatic pressing with a detailed hard mandrel produced a net shape for the internal configuration and thus eliminated the major costs of machining these components.

In the missile wing configuration shown in Fig. 11 which is currently under development, similar cost savings are foreseen with the advantageous application of elastomeric tooling in combination with mandrel technology.

One component currently in production at the rate of 300 parts per month is a titanium alloy Dome Housing for the Sidewinder Missile (See Fig. 12). This item had been machined from a billet blank weighing over 5 lbs. The final shape is machined to close tolerances and a very thin wall of .025 inch (.635 mm). Application of isostatic pressing and vacuum sintering to this component resulted in a preform blank weighing 1-1/4 lbs. and significantly reduced the amount of finish machining necessary. In addition, the final machining required was on a free machining material, thus enabling the close tolerances to be more readily achieved.

In many cases the cost of the P/M preform might well exceed the cost of the billet stock, with significant eventual cost savings still achieved in reduced finish machining. In the specific case of the housing however, the cost of the preform is only 60% the cost of billet, with additional still better savings in finish machining costs.

Both cost savings and energy savings can be obtained through the process described here. Previous manufacture of the Dome Housing from "mill product" required the use of 5 lbs. of material which had to be extracted from ore, reduced and refined, melted and forged.

Since the P/M process starts with powder produced in the manner of sponge, and since the preform blank uses only one fourth as much material, the energy requirements for extraction, reduction and refining are reduced to 25% of the energy needed for conventional processing. In contrast to the significant energy required to vacuum double arc melt and forge to billet 5 lbs. of material is the much reduced energy to press and vacuum sinter only 1-1/4 lbs. to preform shape. Finally, even finish machining to final dimensions of both the wrought and P/M preform results in still additional energy savings due to the free machining aspect of the material.

Other Materials

The technology above has been applied to materials other than titanium ⁽⁴⁾ ⁽⁵⁾. Stainless steels, tool steels, aluminum alloys, copper, nickel, Hastelloy C and the refractory metals among others have all shown technical promise and economic advantage with these processes. Increasing commercial acceptance and significant utilization of this technology is anticipated in the immediate future.

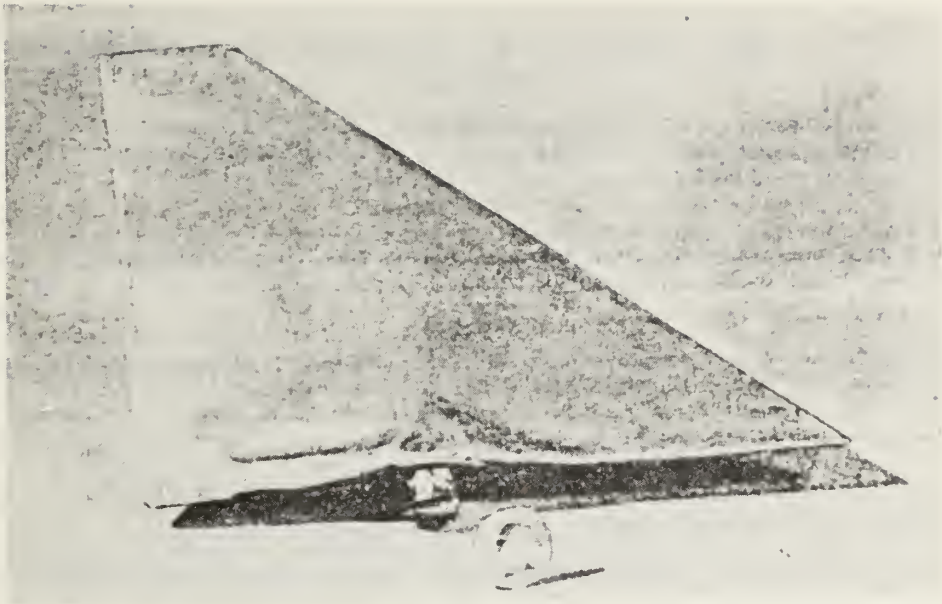

FIG. 11

Ti-6Al-4V MISSILE WING ISOSTATICALLY PRESSED AND VACUUM SINTERED

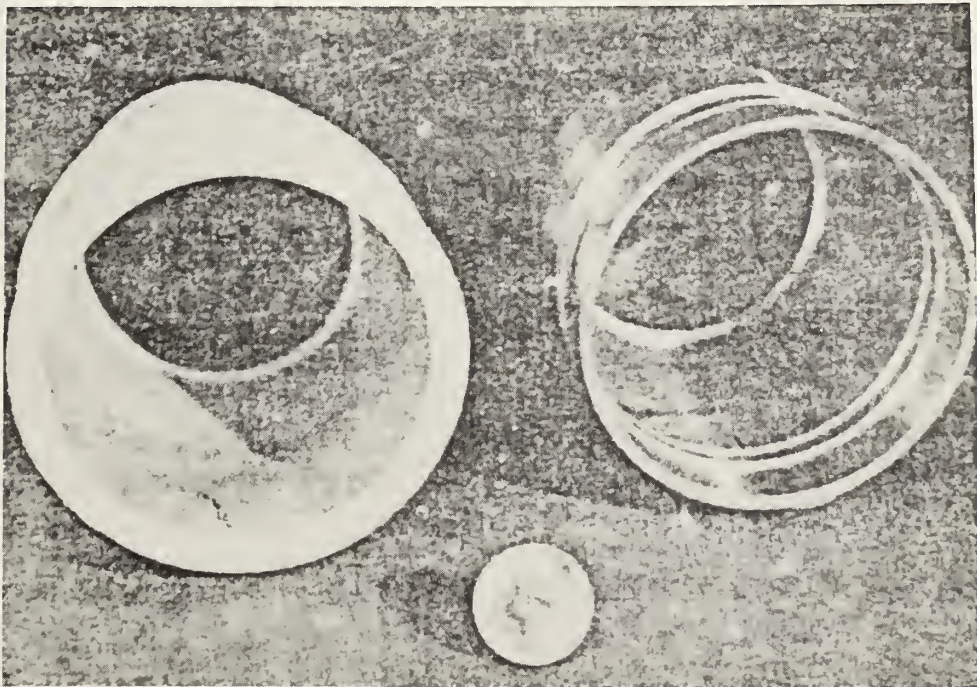

FIG. 12

Ti-6Al-4V ALLOY DOME HOUSING PREFORM LEFT
FINISHED MACHINED COMPONENT RIGHT

References

- (1) S. Abkowitz, J. M. Sierjiej, and R. D. Regan "Titanium P/M Preforms, Parts and Composites". Proceedings of 1970 international Powder Metallurgy Conference, Vol. 4, Pages 501-511.
- (2) S. Abkowitz "Cost Savings in the Application of P/M Titanium and P/M Aluminum Alloys". 1974 National Powder Metallurgy Conference Proceedings, Vol., 30, Pages 85-101.
- (3) Metcut Report to Dynamet Technology "Drilling Pressed and Sintered Titanium 6Al-4V". Metcut Report No. 1023-12894-1, February 1969.
- (4) "Developments in Titanium and Aluminum P/M Technology", Precision Metal Magazine, September 1974, Pages 44-48.
- (5) "Cold Pressing Opens the Door to Complex Shapes", Iron Age Magazine, May 9, 1977, Pages 39-41.
- (6) S. Abkowitz, "Isostatic Pressing of Complex Shapes from Titanium and Other Materials" 10th National SAMPE TECHNICAL CONFERENCE, Kiamasha Lake, New York, 1978.

BENEFITS OF TITANIUM IN AIRFRAMES AND
COMPROMISES IN SUBSTITUTION

Donald G. Goehler and A. Lew Wingert
Boeing Commercial Airplane Co.

BENEFITS OF TITANIUM IN AIRFRAMES AND
COMPROMISES IN SUBSTITUTION

Donald D. Goehler and A. Lew Wingert
Manager, 757 Materials Technology
Boeing Commercial Airplane Company

ABSTRACT

The Boeing Company has used titanium from the time it became commercially available to enhance the performance of our products. Each new product has used more titanium than earlier products, and it is expected that this trend will continue. Supersonic cruise vehicles will require that substantial amounts of their airframes be fabricated from titanium to optimize their efficiency. Substitution of other metal alloys for titanium in existing and some future application extracts a penalty in performance.

INTRODUCTION

Titanium has been the subject of research, development, and application at The Boeing Company since the late 1940s. Its properties of high strength, low density, and corrosion resistance make it very desirable as an airframe material. Initial efforts by our manufacturing department to make airplane parts, however, were marked by high cost and limited success. The titanium industry was encouraged to invest private capital in equipment and techniques that would give us raw material forms that we could easily shape into parts for air vehicles. We invested our own research money and participated in government research to form, weld, fasten, cast, and machine titanium. Slowly, commercially pure titanium, then Ti-6Al-4V, found increasing applications, as shown in Figure 1. Starting with the WS-110A

(eventually called the B-70), then the supersonic transport, Boeing encouraged the titanium industry to build additional production capacity using their own capital. Figure 2 shows the results of program cancellations on titanium production and shows why that industry has difficulty funding expansions.

These airplane programs, even though cancelled, made us more familiar with the characteristics of titanium. We learned that strength at elevated temperature was unmatched by any other metal of the same or lower density. Its corrosion resistance, comparable to stainless steel, meant that parts could be used in corrosive environments, such as landing gears, without special plating processes. We also remained firmly convinced that titanium was right for any supersonic cruise air vehicle.

Although we still use commercially pure titanium for ducts and tubes, our interest and major uses turned to the alloys of titanium, particularly Ti-6Al-4V, which has served as a workhorse for the aerospace industry since the late 1950s. Its moderately high strength, 120,000 psi ultimate tensile, made it competitive with the high-strength aluminum alloys in a strength/density comparison. In the middle 1960s, we applied Ti-6Al-6V-2Sn at 160,000 psi ultimate tensile strength, which allowed titanium to compete directly with ultra-high-strength steel alloys in landing-gear applications. Our newest airplane, the 757, is applying Ti-10V-2Fe-3Al at 180,000 psi ultimate tensile strength, which exceeds the strength/density of ultra-high-strength steels (Figure 3). Substituting this alloy for Ti-6Al-4V in our main landing gear beam saved approximately 125 pounds per airplane.

To illustrate the expanded use of titanium at Boeing, the amount of titanium in the airframe of the 727 is less than 1 percent (1300 pounds), whereas there is 4-1/2 percent (11,000 pounds) titanium in a 747 airplane. When you include the engines, we buy about 72,000 pounds of titanium raw material for every 747 we build. The 757 will have 6-1/2% titanium in

its airframe when it rolls out in December, 1981.

From the above, it can be seen that titanium technology is a vital tool for Boeing when building competitive products in a world aerospace market. Our own up and down requirements, the supply complexities, and our need to reliably build products on schedule cause us to examine the process of decision making when selecting or substituting materials.

THE MATERIAL SELECTION PROCESS

Thousands of highly trained people, with the best tools in the world, highly experienced in the many complex disciplines required to thrive in a high-technology, worldwide enterprise, spend about 4 years to develop, sell, design, procure, build, test, and deliver a new airplane. In production, some components, like the 747 main landing gear beam (Ti-6Al-4V), must be ordered 4 years before we install them in the airplane. Therefore, the decisions about what materials we use to build a Boeing airplane must be made reflecting all of the business opinion and supply questions, as well as airplane design efficiency.

When it is decided what materials we will use, it requires fast footwork and shrewd negotiations all over the world by our procurement specialists to ensure that those materials, meeting our specifications, arrive in time to build the planes.

Decisions regarding whether or not to use titanium must reflect the following realities:

- o Supply--today and 4 or 5 years ahead
- o Cost--measured by cost to save a pound of weight
- o Facilities--forging, foundry, and machining capacities
- o Design problems--can other materials do the job for the same weight?

Supply

The key to the supply of titanium lies in sponge production. When Russia withdrew their supply, our ability to support ingot production became tight. The supply of ingot material is very close to the market demand. By importing some ingot and forgings, we are just meeting demand. It is our speculation that the industry can supply our current and projected needs IF no new substantial demand is established. It is highly probable that airlines will want more aircraft fuel efficiency. Our fuel-efficient engines require titanium. We can apply titanium to build lighter airframes, but if a military or other government program establishes priority requirements on the existing titanium capacity, perhaps we should use another approach to save weight, in order to protect our supply of engines. Figure 4 illustrates that nonaerospace products are beginning to take a larger slice and that steadily increasing demand will probably continue putting even more pressure on the supply part of the formula.

Cost

Currently, a 747 costs \$70 million to an airline. We have to build and test that airplane to their satisfaction for something less than that in order to remain in business. We are today competing with whole groups of nations, as well as other aerospace businesses, making our costs especially sensitive in the decision process. Our way of deciding is to have our various experts process the decisions on the basis of real cost to save a pound of weight. Material selections must be made very early in the design process, when little is known about part geometry, making those decisions very difficult. Government titanium research (AFML, U.S. Navy, U.S. Army, NASA funded) has developed and offered technology to our industry, leading

to lower, more competitive costs per pound. These activities must continue. If, however, the material itself is prioritized out of existence to us in the commercial world, the cost per pound evaluation becomes meaningless.

Facilities

When we build an airplane at Boeing, we accomplish about 35% of the total job. Our subcontractors and suppliers throughout the world do the rest. Foundries, forge shops, machine shops, etc., and their production capacities are an important part of any successful formula. In 1979, the lead time to procure a large titanium forging was 155 weeks--nearly 3 years. This is devastating when trying to support a production program to guarantee delivery dates.

Design Problem

Some parts of an airplane have to be titanium. Engines, as mentioned, must use substantial amounts of titanium. The basic fuel-efficient engines are P&W-JT9, GE-CF6, and RR-RB211. Even our Airbus competitor uses these engines and most, if not all, of the titanium in these engines comes from U.S. capabilities (about 2,000 pounds per engine). In elevated-temperature design applications (300 to 800°F), titanium performance cannot be duplicated. In room-temperature applications, some of the higher strength titanium alloy applications cannot be duplicated, but other parts can be designed in steel, with only slightly higher weight. For subsonic aircraft, most of the airframe can be, and is, designed best with aluminum alloys. An increasing trend is to use graphite/epoxy composite hardware to replace aluminum and fiberglass. Interestingly, this increases the amount of titanium used for fittings and fasteners, since titanium is very compatible

with graphite.

The design part of the formula works out in summary like this:

1. Engines must be designed in titanium.
2. Supersonic cruise air vehicles must be designed in titanium.
3. Certain parts of heavily loaded subsonic or transonic air vehicles should be designed in titanium alloys.
4. Some parts of subsonic air vehicles and other products will perform better with titanium, depending on economic considerations.

To illustrate point 4, let's look at the 747. To replace only the titanium parts that could be aluminum or steel would add approximately 10,000 pounds to the airplane. This means that to fly the long-range segments of air routes for which most airlines use the 747, they would have to take out over 50 seats or leave behind 10,000 pounds of revenue cargo.

The design part of the formula, in what we see of the future, weighs heavily toward expanded use of titanium. There is, however, only a finite amount of "fast footwork" available to our procurement people when the other realities of the total equation are considered.

NEEDS

Paramount to Boeing is the need to establish a steady supply of the various forms of titanium alloys as we need them. Our current commercial airliner needs center on billet for forgings with smaller amounts of sheet, strip, and bar. Increasingly, castings are becoming important, due in large measure to the success of Air Force research and successful experience in engines. Federal research in titanium needs to be continued in the direction of higher strength alloys and lower cost and new ways of fabrication. Powder metallurgy and superplastic forming/diffusion bonding are fields where federal research has paid off, putting the U.S. well ahead

of the rest of the world. Research in substitute metal systems which could be used with no weight, cost or performance penalties needs to be encouraged.

CONCLUSIONS

- o The availability of titanium is tight, but adequate, for today's requirements.
- o Boeing will continue to expand its use of titanium and to use technological advancements as they emerge.
- o A new supersonic cruise vehicle or major military production buildup without a pound-for-pound increase in titanium raw material capability (primarily sponge capacity) would adversely affect our ability to compete in the world commercial and military market.
- o Titanium technology, as led by federal research agencies and private investments, has put this country well ahead of the rest of the world. These activities need to be continued.
- o Research in substitution technology needs to consider titanium.

RECOMMENDATIONS

- o Clearly establish that any expansion of military programs that will use titanium requires an investment in titanium sponge production by government or industry with tax credits or other monetary encouragement.
- o Bring stockpiles of titanium up to required levels by exercising a planned expansion with purchases during industrial slumps and bartering on international trade.
- o Insure that any research in substitution technology will consider titanium and titanium alloys.

Titanium Usage by Model

Commercial Aircraft Mill Product Requirement

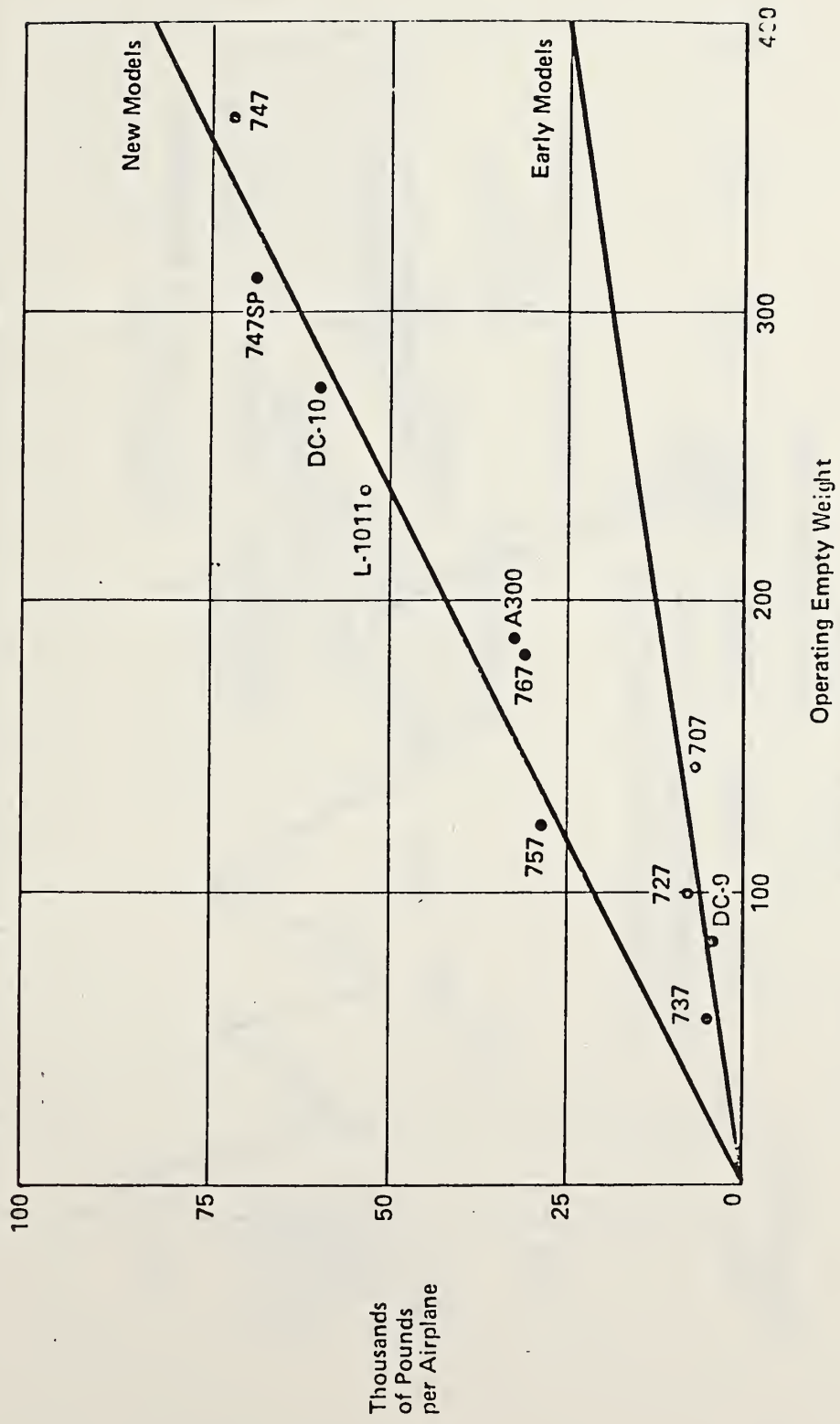

FIGURE 1

Titanium Mill Product Shipments 1964 - 1981

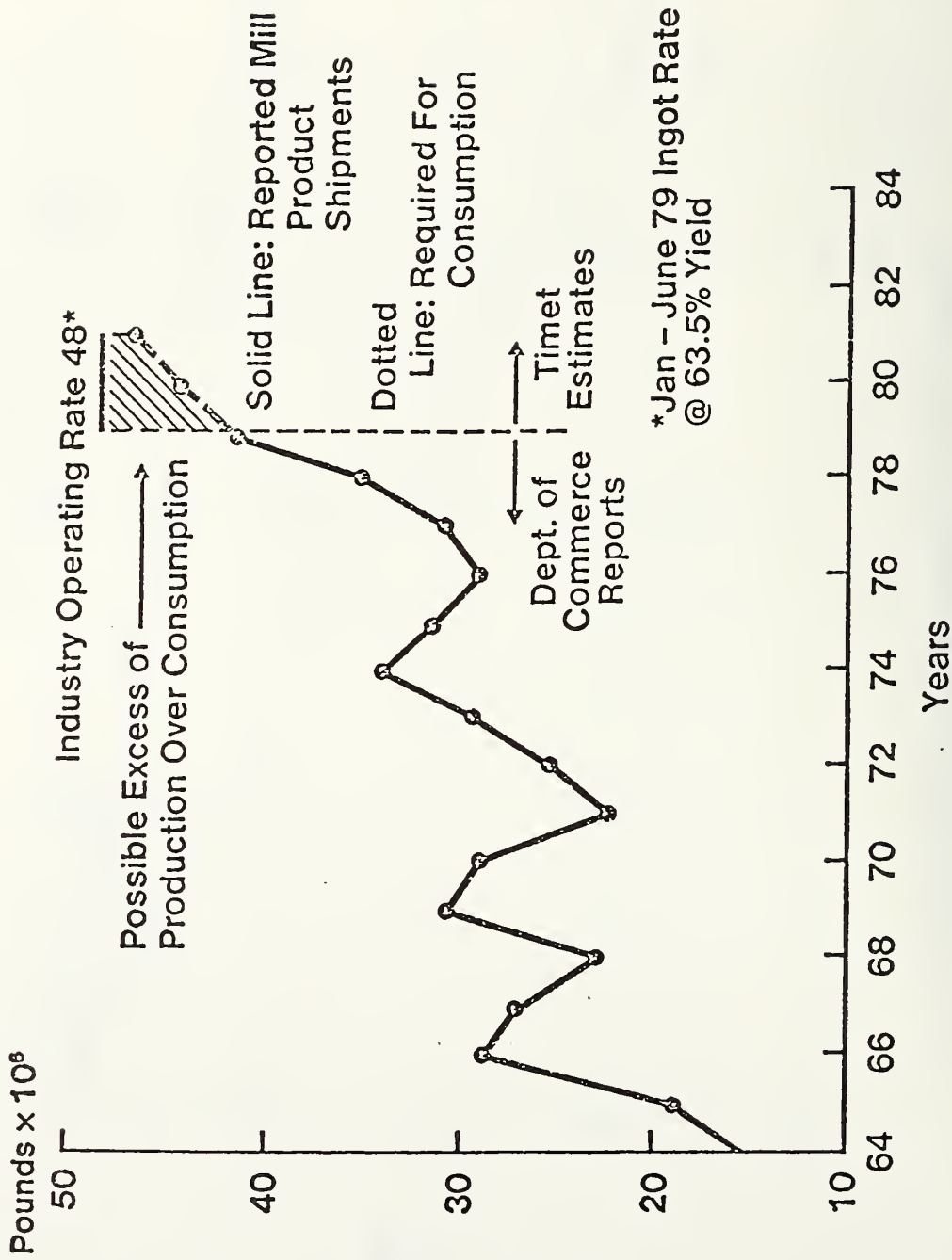

FIGURE 2

Structural Materials Trends

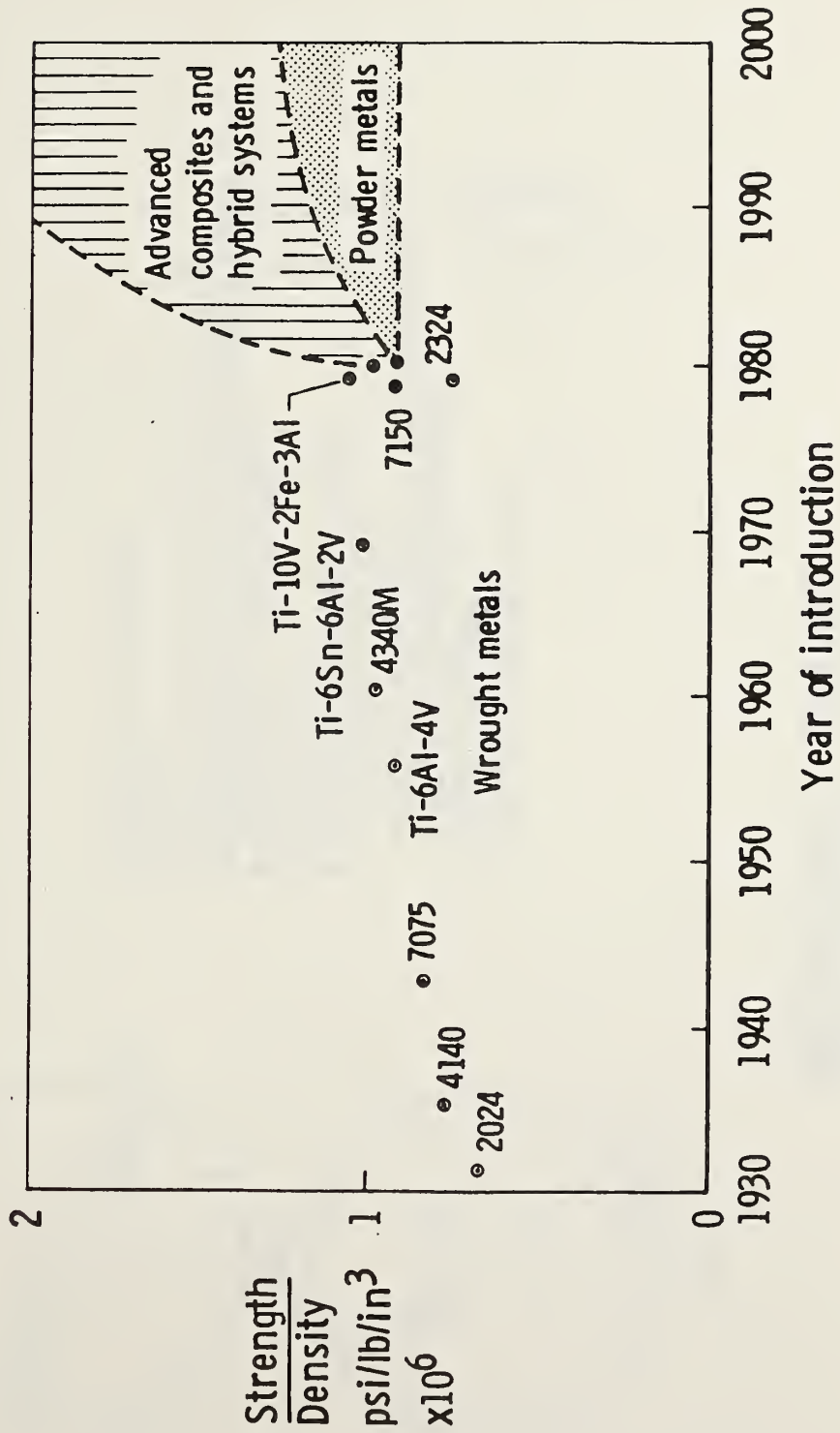

FIGURE 3

INDUSTRIAL USAGE



FIGURE 4

TANTALUM AND OTHER CRITICAL ELECTRONIC MATERIALS

Thomas D. Schlabach
Bell Telephone Laboratories

Tantalum and Other Critical Electronic Materials

by

T. D. Schlabach

Bell Telephone Laboratories

Murray Hill, New Jersey 07974

1. Introduction

The electronics industry is a strong contributor to our economy and to our technological leadership in the world. In 1979, it had sales of \$81 billion and a trade surplus of nearly \$5 billion while employing 1.5 million workers according to the Electronics Industries Association and as shown in Table 1. Its use of materials ranges from gross to atom-by-atom additions in products that are very expensive compared to most other products so that starting material costs are seldom overriding. Nevertheless, the issues of materials conservation and substitution are very important to this industry and can present it with exceedingly difficult problems. These problems will be reviewed here for several materials considered critical to our industry.

2. Electrical-Electronic Demand and Import Levels

The criticality of an element to an industry includes its level of use, its substitutability and the vulnerability of its supply sources to interruption. Table 2 gives the

percent demand in the electrical-electronic sector for 23 of the most important elements to this industry and Table 3 shows their import levels. Those that combine a high level of use with high import level include tantalum, gallium and strontium though the latter has large and diversified foreign sources. Those that combine moderate to high use and import level with difficulty of substitution include the platinum-group metals, tin, mercury and gold. The remaining are less critical by these criteria though supply interruption of them can cause, and has, substantial problems. Three elements on this list; namely cobalt, nickel and tungsten, are dealt with elsewhere in this workshop and will not be treated further here.

3. Tantalum

Tantalum, by virtue of its large electronic use as seen in Table 4 and its high import level, is a critical element to the electronics industry and a strategic element to the U.S. Imports of tantalum-containing concentrates and tin slags provided 97 percent of U.S. apparent consumption which amounted to nearly 1.5 million lbs. in 1980. Only 3 percent of supply comes from recycling though secondary production from run-around scrap is substantial. Worldwide resources are judged adequate to meet projected world needs through the year 2000 by the U.S. Bu Mines though highly dependent on Zaire and Nigeria if U.S.S.R. resources are excluded. The dependency of a good portion of tantalum supplies on tin

slags, something like one-third, could portend future supply problems because, while tantalum growth is estimated by the U.S. Bu Mines at 4%/yr. out to the year 2000, tin growth is estimated at only 1%/yr. High recent prices for tantalum has encouraged supply expansion in Brazil, Canada and Australia.

4. Capacitors

The principal electronics use for tantalum is in capacitors where it competes with the other types shown in Table 5 which lists U.S. sales for all except captive capacitor production. Because tantalum solid electrolytic capacitors exhibit high reliability, long life and high specific capacitance per gram combined with low noise and dissipation factor, they have grown to command more than two-thirds of the total electrolytic capacitor market (1). Aluminum electrolytic capacitors have made significant inroads, however, in low impedance and consumer applications by technical improvements and by their lower costs. At the same time, notable improvements continue to be made in the capacitance ratings of tantalum powders to increase their efficiency through increased specific surface area. These ratings, expressed as a capacitance-voltage product per gram, are expected to increase from 5000 in 1980 to 10,000 in 1985 in production capacitors. Laboratory samples have been reported to exceed this value already and even higher values are distinctly possible. The monolithic ceramic capacitors

are enjoying the fastest growth because of their use with silicon integrated circuitry.

The substitution possibilities for tantalum capacitors offered by aluminum electrolytics and monolithic ceramics combined with continued improvements in capacitor-grade tantalum powder have decreased growth estimates in this area from 7 percent to 4 percent. These changes together with higher production capabilities being brought on stream by higher tantalum prices improve the supply situation for tantalum over the near term. Beyond this, research has been conducted on niobium, hafnium and titanium as possible substitutes in solid electrolytic capacitors without notable success to date. This effort could be renewed if needed.

5. Elements Presenting Difficult Substitution Problems

The elements shown in Table 6 are among those for which substitution is very difficult, if not impossible, by virtue of their unique properties and applications, and for two of these we are heavily import dependent (2). Platinum-group metals are essential for certain electrical contact uses and indirectly essential in providing crucibles and other equipment for the growth of single crystals and glasses. For these uses there are no satisfactory substitutes. Mercury is essential for wetted contacts and, again, no satisfactory substitutes exist though designs continue to be miniaturized and the stockpile contains nearly 3 years demand. Tin is essential to solders although its use in electrical

applications has decreased 30 percent over the past decade due to lower tin contents in solders and the higher level of interconnection on silicon chips and hybrid integrated circuits. Further, large holdings are in the stockpile and for tins major use in containers viable substitutes exist that could free a large fraction of tin demand.

Mercury is the only one of these three for which worldwide reserves appear inadequate to meet the world's cumulative demand out to the year 2000. The fact that platinum-group metals come principally from the Republic of South Africa and the U.S.S.R. raises questions concerning our vulnerability to supply interruption.

6. Gold Conservation and Substitution

Gold presents a different problem in conservation and substitution arising from its high cost and the fact that it confers a degree of reliability in electronic devices and apparatus that is unmatched. This led naturally to the use of large amounts of gold in electronics and to intensive efforts now to conserve and substitute for gold whenever possible. Since most of this use is in the form of electro-deposited coatings, conservation steps have included selective area plating, thinner coatings and composite structures with gold or gold alloy cladding. Beyond this, substitution possibilities are being intensively examined for contacts and some of these are listed in Table 7 where they are compared to gold. Other cheaper, precious metal alloys are one

obvious possibility and base metal contacts are another. Composites of the kind shown are a more radical departure but being explored in certain less critical applications. Even metallic conducting compounds have received attention. In all of these cases, there is an attempt to match a substitute material with the particular requirements for that application in the hope that it can prove adequate.

7. Germanium

Germanium, gallium and indium are three elements critical to some of our newest electronics technologies and for this reason it is appropriate to examine their supply-demand status. They are used currently in comparatively small amounts and, while they do not pose strategic problems, there is some concern about the adequacy of their short-term supply.

Germanium is obtained as a by-product concentrate from zinc mining and potentially huge, but untapped, resources exist in coal flyash where germanium concentrations of several 100 ppm are common. In 1980, the apparent U.S. consumption of germanium was 77,000 lbs. with imports equal to 17 percent of this demand according to the U.S. Bu Mines. The major use of germanium is in infra-red optical systems which accounted for some 53 percent of uses in 1980 (see Table 8). Under electronics, semiconductor use peaked in 1967 but germanium used as GeO_2 in optical fibers for lightwave communications is an emerging application

estimated to require 11,000 lbs./yr. starting in 1981. These fibers with germania-silica cores exhibit very low optical signal attenuation and provide a low-cost, high information-carrying capacity transmission medium. Interest in lightwave communications is growing rapidly throughout the world and will displace a certain fraction of copper use in communications. Because of substantial growth in germanium usage in both optics and electronics, some shortage may appear in 1981 but there is every prospect of adequate supplies in 1982 and thereafter to meet the projected growth of 5%/yr. through 1990.

8. Gallium

Like germanium, gallium is obtained as a by-product in the production of aluminum and zinc and is potentially recoverable from coal flyash. Bauxite, the most important source, contains 30-90 ppm gallium (3). U. S. consumption of gallium was reported at 9,500 kg in 1980 by the U.S. Bu Mines with imports supplying 70 percent of this demand and recycling none. Gallium's predominant uses are electronic (see Table 9) and require for the most part six nines purity material. These uses include: 1) light-emitting diodes, 2) other infra-red sources and detectors, 3) amplifiers and oscillators in high-frequency systems, 4) bubble memory substrates, 5) photovoltaic devices, and 6) superconductors. These and other gallium uses are anticipated to grow at 6%/yr. through 1990 but beyond that growth is highly depen-

dent on the availability and large-scale commercialization of gallium arsenide photovoltaic systems for the direct conversion of sunlight to electricity. Far smaller, but important emerging uses of gallium are as sources and detectors in lightwave communications systems and as bubble memory substrates. These are both areas having very high growth rates. It appears that there will be sufficient world-wide production capacity and gallium resources to meet anticipated world needs out to the year 2000.

9. Indium

Indium is obtained as a by-product of zinc production and its supply is determined by this. World production of indium was estimated at 1.6 million troy oz. in 1980 by the U.S. Bu Mines and imports were 0.3 million troy oz. Modest recycling occurs. U.S. production and consumption figures are not available. Forty percent of indiums uses are in the electric-electronic sector (see Table 10) and include: solders, contact coatings, transparent and conducting coatings on glass, infra-red detectors and sources, and photovoltaic devices. As with gallium, the market having the largest potential use is that of photovoltaics for energy conversion. Infra-red sources and detectors, based on InGaAsP, for lightwave systems and transparent conducting coatings on glass are two important and growing areas. While U.S. reserves to meet U.S. demand out to the year 2000 appear inadequate, world reserves to meet world needs appear

adequate. In a number of its uses, indium has available substitutes.

10. New Technologies and New Material Use Patterns

While it is vital to establish material conservation and substitution possibilities for our critical and strategic materials, none of these is likely to be more important than the new technologies developed to perform needed functions in wholly novel ways. These so-called functional substitutions (4) offer the greatest opportunity for profoundly altering, and often reducing, our use of materials and energy though they are not solutions that can be rapidly and simply implemented. The system-like nature of these solutions require substantial time for success and implementation. Nonetheless, numerous information- and energy-related technologies are underway, some of which are noted here, that offer marked material and energy savings and that can ease the problems facing us in this area.

11. References

1. Bernard, W. J., "Developments in Electrolytic Capacitors," J. Electrochem. Soc., 174: 403C-409C (1977).
2. Schlabach, T. D., "Critical Materials and Substitution Strategies in the Communications Industry," Metal Prog. 117(2): 57-62 (1980).
3. Rosi, F. D., "A Survey of the Market, Supply, and Availability of Gallium," Mats. and Society 4: 349-365 (1980).
4. Chynoweth, A. G., "Electronic Materials: Functional Substitutions:" Science 191 725-732 (1976).

TABLE 1

U.S. ELECTRONICS INDUSTRY, 1979

Factory Sales	\$80.6 billion (+ 14%)
U.S. Gov't.	\$20.2 billion (+ 14%)
Exports	\$16.7 billion (+24%)
Imports	\$11.7 billion (+ 10%)
Employment	1,464,000 (+ 11%)

EIA 1980

TABLE 2

ELECTRICAL-ELECTRONIC DEMAND.
PERCENT U.S. TOTAL DEMAND, 1980.

>90	Y, Ga
51-90	Sr, Pb, Ta, Cu, Be, Hg
26-50	Cd, Ge, Au, Se, Pd, Ag
10-25	Sb, Sn, Ni, Co, Al, Pt, Zn, W, In

TABLE 3

IMPORTS FOR ELECTRONIC ELEMENTS.
PERCENT APPARENT U.S. CONSUMPTION, 1980.

>90	Sr, Ta, Pt, Pd, Co, Bauxite
51-90	Ga, Cd, Sb, Sn, Ni, Zn, W
26-50	Hg, Au, Se, In
10-25	Cu, (Ge)
<10	Y, Pb, (Be), Ag

TABLE 4

TANTALUM, 1980

Mine Production: Canada, Brazil, Australia

Reserves: Zaire, Nigeria, Thailand

Uses:	Electronic	66%
	Machinery	26%
	Transportation	8%

Substitutes: Capacitors, Al, Ceramics;
Superalloys + Carbides, Nb

TABLE 5

CAPACITORS, FACTORY SALES (MILLIONS) 1979.

Type	Units	\$
Tantalum Electrolytic	899	262
Aluminum Electrolytic	205	185
Ceramic Dielectric	4,371	352
Film Dielectric	621	214
Other	60	38
Total	6,156	1,050

EIA 1980

TABLE 6

CRITICAL METALS, 1980

METAL	CONSUMPTION, PERCENT			GSA STOCKPILE, months demand
	elec.	Imp.	sec.	
Pt-Group	24	87	16	9
Hg	52	49	21	31
Sn	15	85	25	46

TABLE 7

CONTACT PROPERTIES OF VARIOUS MATERIALS

METALS	RESISTIVITY microhm-cm	DENSITY g/cm ³	COST = vol. rel Au
Au	2.35	19.3	100
Au (plated hard)	4.5	17.5	90
Pd	10.8	12.1	19
Pd-40Ag	42.0	11.3	11
Sn	11.4	7.3	0.04
COMPOSITES			
Ag-Epoxy	100	1.5	4
Graphite-Polymer	10 ³ -10 ⁴	1.5	0.02
COMPOUNDS			
RuO ₂	50	7.0	1.4

TABLE 8

GERMANIUM, 1980

Plant Production: W. Europe, U.S., U.S.S.R.

Reserves: U.S., Africa, W. Europe

Uses:	Instruments + Optics	53%
	Electronics	41%
	Other	6%

Other Resources: Coal

Substitutes: Semiconductors, Si, Ga, In;
Optics, Zn, Se

TABLE 9

GALLIUM, 1980

Production: U.S., Switzerland, Canada

Reserves: India, Surinam, U.S.

Uses: Electronics	93%
R+D	7%
Dental Alloys	<1%

Other Resources: Coal, Kaolin

**Substitutes: Semiconductors, Si, Ge, In;
Displays, Liquid Crystals**

TABLE 10

INDIUM, 1980

Refinery Production: Japan, U.S.S.R., Canada

Reserves: Canada, U.S., U.S.S.R.

Uses: Electronic	40%
Solders + Coatings	40%
Research + Other	20%

**Substitutes: Semiconductors, Si, Ge, Ga;
Reactors, Hf; Solders, Bi**

TANTALUM IN HIGH TEMPERATURE ALLOYS

James A. Ford and Robert B. Herchenroeder
Cabot Corporation

Tantalum in High-Temperature Alloys

James A. Ford and
Robert B. Herchenroeder

Cabot Corporation

Workshop on Conservation and Substitution
Technology for Critical Materials

June 15-17, 1981

Vanderbilt University
Nashville, Tennessee

Tantalum in High-Temperature Alloys

Robert B. Herchenroeder

INTRODUCTION

In this presentation, three aspects of tantalum (Slide 1) will be considered: (1) background, covering general information on uses of tantalum, past production, estimates of future production, and division of tantalum among customers; (2) the main topic of the presentation which is the role of tantalum in superalloys and the possibilities of substitution of other elements; and (3) the possible "sleeping giant" consumer of this critical material, the chemical process industry.

BACKGROUND

Slide 2 shows the sources of tantalum concentrates in the past three years and indicates a near doubling of imports in this time period.

Slide 3 reviews the growth pattern of tantalum and tantalum mill products from 1976 through 1980 and gives an estimate of consumption of these products through 1985. Note, the next five years appear to be a repeat of the past five years.

Slide 4, similar to the previous one, but for tantalum remelt, predicts almost a 70 percent increased use of tantalum for alloying in the period of 1980 through 1985.

Combined (Slide 5), the overall prediction is a drop in consumption of mill products and remelt stock for 1981 and then a continual growth of about 50 percent through 1985.

Note this series of graphs does not include tantalum consumed for capacitors, but it does include lead in wires associated with capacitors. The data are for U.S. production and consumption only.

During 1980, about 853,000 pounds of tantalum powder were used for capacitors. Combining this with the other available data (Slide 6) it is shown that only about 11.5 percent of the total consumed was used for alloying.

Slide 7 is a condensed listing of the applications for tantalum and its alloys showing widely diversified consumers. Applications range from heat exchangers to exotic electronic instruments.

Finally, in the way of background, Slide 8 lists a number of elements which might be considered as substitutes for tantalum in superalloys. Since cost also is indicative of availability, the list, indirectly, suggests how suitable these elements would be for substitution in case of emergency. Costs are for sponge, anodes, or high grade scrap.

The Role of Tantalum in High-Temperature Alloys

Utilization of tantalum as a significant alloying agent is still in its infancy. A review of the compositions listed in Slide 9 shows most superalloys containing tantalum do so at levels of < 4 w/o. As indicated on Slide 9, it is this group of alloys which are currently being commercially utilized. Despite much publicity about alloys containing > 4%, i.e., as much as 12 w/o tantalum, these high tantalum alloys are still in the experimental and developmental stages and do not currently constitute a significant drain on available supplies of tantalum; they may in the future.

Tantalum is used in commercial alloys of today (Slide 10) to improve strength, surface integrity, and metallurgical stability. The penalties associated with its utilization are mainly cost and increased density of components. However, a \$4-12/per pound increase in metal cost and perhaps a 10% penalty in increased density is more than offset by as much as a doubling of rupture strength (Slide 11),¹ improved long-term ductility, and better corrosion resistance.

The improvements in alloy properties (Slide 12), because of tantalum additions, are related to solid solution strengthening, carbide stability, carbide morphology, gamma prime stability, constitution and morphology, improved castability, i.e., less freckling, and neutral or beneficial effects on corrosion resistance compared to adverse contributions by other possible alloying agents like hafnium, zirconium, and columbium.

Solid solution strengthening is achieved simply because the tantalum atom is larger than that of the nickel (or cobalt or iron) base, and therefore, strains the lattice when it is dissolved in the matrix. If this were the only consideration, other elements such as molybdenum or tungsten could readily be substituted.

Carbide stability is a major reason and consideration for alloying with tantalum. This is especially true for cobalt-base alloys such as 509 which

contains about 4 w/o tantalum. Tantalum monocarbides (TaC) tend to form as primary carbides during solidification of the molten alloy. With appropriate solidification techniques, the form, size, and distribution of the TaC can be controlled to yield spherical, script, or whisker formations.

In the case of alloy 509, the MC (M for metal because rarely are the carbides pure TaC) form typically as Chinese script (Slide 13) and remain in that form even though the alloy is held at high temperatures for prolonged periods.

The NiTaC eutectic alloys are a superb example of advanced utilization of TaC. These alloys containing 6-11 w/o tantalum, perhaps 0.04 w/o carbon, plus other typical alloying elements of cobalt, chromium, aluminum, titanium, and/or vanadium, are slowly unidirectionally solidified in such a manner that nominally 1 micron whisker is continuously grown along the longitudinal axis of the casting yielding a natural fiber reinforced part. (Scredon² gives a brief report of this.) Some of the characteristics of parts made from NiTaC eutectics are listed on Slide 14.

It is reported that researchers have attempted to achieve similar results utilizing other carbides than TaC, but with little success. Possibly, partial replacement of tantalum in the NiTaC with another element could be successful, but this is hypothetical.

As mentioned, the major reason for the use of tantalum as an MC former is its stability. Slide 15 lists the predicted ranking of metal monocarbides based upon the delta-free energy of the metal plus carbon reactions at 1400°K (slightly lower than the temperature of formation of primary carbides).³

Empirically it has been determined (also Slide 15) that both tantalum and columbium monocarbides form in preference to TiC.

Based on this intelligence, it would seem that columbium, a cheaper and more plentiful element, could logically be substituted for tantalum in these high-temperature alloys, but this is not so. In practice, the evolution has been from columbium to tantalum.

As mentioned, columbium carbide does not have an optimum morphology. Further, even though the simple thermodynamic calculations suggest TaC and CbC ΔG_R are close, i.e., -33610 and -32707 calories, respectively; other factors influence the systems. Slide 16 illustrates these.

The refractory metal monocarbides are seldom pure. The MC, containing a preponderance of columbium, frequently and typically break down and dissolve initially in the matrix. Depending upon the alloy system and temperature and time lapse, the columbium may combine with the γ' frequently displacing chromium which then in turn combines with the available carbon to form $M_{23}C_6$ or M_6C which usually precipitates in a detrimental manner. It may combine with other elements of the alloy to form sigma, Laves, or other topologically closed packed phases; but, almost without exception, the columbium does not recombine to form CbC and the second state of the alloy is less desirable than that of the first.

Hafnium, another possible substitution for tantalum, based on Gibb's free-energy considerations, has been successfully used in gamma prime strengthened alloys for 10 to 15 years. This element does form a stable carbide and is used in amounts of 0.5 to 2% to control the morphology of grain boundary carbide precipitation. Typical alloys are B-1900 + Hf and Mar-M-247, which have enhanced ductility as a result of the addition. Unfortunately, supplies of hafnium are as limited as those of tantalum and substitution of it for tantalum is not a good choice for that reason.

With respect to tantalum's effect on γ' , it is generally accepted that the element improves the high-temperature stability of the phase because it tends to partition in like percentages in both the matrix and gamma prime. It does not alter significantly the equilibrium of the matrix as does most other components of the γ' .

With the advent of single crystal technology for gas turbine blades, tantalum promises to be a major alloying element in the next generation of alloys. Without grain boundaries, carbon, hafnium, and boron (grain boundary strengthening elements) can be eliminated and tantalum, chromium, and tungsten can be increased as has been done in PWA alloy 454 to improve strength and oxidation resistance.

Copley, et. al.⁵ slide 17 explains that in addition to the others attributes of tantalum, tantalum significantly reduces the tendency toward "freckling"* in castings.

Mr. Gell and co-workers at Pratt & Whitney Aircraft are reported to have said "...this element (tantalum) alone among the third series transition elements confers both high levels of creep strength and oxidation resistance."

Frequently, the substitution or replacement of tantalum for columbium in an alloy results in marked improvement of oxidation and hot corrosion resistance. If one compares the oxidation resistance of WI 52 (a cobalt-base alloy containing 2 w/o Cb) with that of Mar-M-509 (a cobalt-base alloy containing 4 w/o Ta) this aspect is readily noted.

Slide 18 clearly shows that while tantalum may not improve oxidation resistance per se, it does not degrade resistance as does columbium. This is from work done in the Technology laboratories during the development of HAYNES alloy No. 556. The base composition was modified as indicated with varying amounts of columbium, tantalum, and lanthanum.

* freckling in alloys results when elements such as columbium, tungsten, chromium, and molybdenum segregate during casting to form distinctive, separate bodies in the solidified alloy.

Fryburg, et. al.⁶ (Slide 18) noted that those alloys containing high tantalum are more resistant to hot corrosion attack than those with lesser amounts.

A proposed mechanism of NaSO₄-induced corrosion of B-1900 alloy is that the protective Al₂O₃ scale at 900°C is dissolved by liquid Na₂MoO₄ which is formed by the reaction



Once the Al₂O₃ protective scale is penetrated, corrosion attack is swift.

When significant amounts of tantalum are present as in TRW VIA with 9 w/o tantalum, it is thought that the Na₂SO₄ reacts with Ta₂O₅ to form preferentially NaTaO₃, a solid, according to the reaction



In this instance, the MoO₃ volatilizes; the Al₂O₃ protective scale remains in tact.

Substitution of other elements in lieu of tantalum on the basis of oxidation resistance and surface stability is not attractive. Columbium causes spallation of both Cr₂O₃ and Al₂O₃ scales. Molybdenum forms liquid or gaseous MoO₃ which can be most harmful especially in static atmospheres.

Zirconium, while beneficial in small quantities, reacts with mold materials, collects along grain boundaries where it oxidizes preferentially, and forms undesirable intermetallics when utilized in any substantial amount (> .5 w/o).

Tantalum is a unique element which beneficially affects many aspects of superalloys. In general, substitution of one or more elements for tantalum in the new generations of superalloys would incur meaningful penalties with respect to almost all aspects of the resulting alloy's performance.

In effect, the current and promised new era of cast superalloys would have to revert to the technologies of the late 1960s and performance of equipment utilizing these superalloys would be materially impaired.

Tantalum Potential in CPI

Perhaps the largest eventual consumer of tantalum will be the chemical process industry (CPI). As such, it can be a major factor in availability during a shortage of this potentially critical material. During 1981, a down year, it is anticipated that about 60,000 pounds of tantalum will be used in CPI. Much of the future growth of mill products is expected to be in CPI applications.

From basic electrochemical determinations (Slide 20) one would expect that tantalum, a relatively active material chemically, would have poor aqueous corrosion resistance, but this is not the case in actual practice (see Slide 21). Tantalum and its "sister" element columbium tend to form thin amorphous films that provide superb corrosion resistance through passivity to most acid combinations.

The near perfect resistance of tantalum to acids, as indicated, coupled with the high cost of construction and maintenance of chemical plants, pleads well the case of tantalum. Tantalum as a thin cladding on less corrosion-resistant materials becomes more cost effective each day.

In considering critical needs along with possible shortages, one should anticipate the likely high demands which will be associated with CPI.

Summary

Tantalum is a unique alloying element for superalloys which affects numerous aspects of an alloy's performance, including strength, surface integrity, fatigue life, metallurgical stability, and castability.

The use of this element for alloying has been retarded and remains at a relatively low level because of cost and density penalties, but the advantages achievable through new technologies such as directional solidification more than counter these adverse effects. Use should increase dramatically. Cost of tantalum in relation to total cost of an advanced design cored and directionally solidified aircraft airfoil is insignificant.

Because of the special characteristics of this element for imparting beneficial effects to alloys it is virtually impossible to substitute another element and retain similar life expectancies from the parts made there from.

The chemical process industry will probably contribute to the shortage and consumption of tantalum in the immediate future and this should be considered in any plans for allocating this element.

References

1. N. N. Burova, et. al., "Structural Characteristics of Nickel Alloys with Tantalum," Metal Science and Heat Treatment, May-June, 1979.
2. S. Scredon, "Next Generation Superalloy is Cast into Blade by G.E.," AMM-MN, August 18, 1980.
3. Barin, Knacke, and Kubaschewski, "Thermochemical Properties of Inorganic Substances," Springer-Verlag, 1977.
4. Atlas of Microstructures, ASM Handbook, 8th Ed., Vol. 7.
5. S. Copley, et. al., "The Origin of Freckles in Unidirectionally Solidified Castings," Met. Trans., Vol. 1, No. 8, 1970, p. 21.
6. G. C. Fryburg, et. al., "Mechanism of Beneficial Effect of Tantalum in Hot Corrosion of Nickel-Base Superalloys," J. Elec. Chem. Soc., July, 1977.

SLIDE 1

TANTALUM IN HIGH-TEMPERATURE ALLOYS

THREE TOPICS OF DISCUSSION

1. USES AND DISTRIBUTION OF TANTALUM.
2. ROLE OF TANTALUM IN SUPERALLOYS.
3. THE "SLEEPING GIANT" CONSUMER - CPI

RBHH

6/81

SLIDE 2

I. SUPPLIES

U. S. IMPORTS OF TA CONCENTRATES, LBSX10⁻³

<u>COUNTRY</u>	<u>1978 (%)</u>	<u>1979 (%)</u>	<u>1980 (%) Est.</u>
AUSTRALIA	122 (9)	229 (15)	370 (15)
BRAZIL	174 (12)	179 (12)	550 (22)
CANADA	667 (47)	679 (44)	573 (23)
CHINA	-	-	102 (4)
RWANDA	123 (9)	131 (9)	NA
ZAIRE	160 (11)	75 (5)	NA
ALL OTHERS	183 (13)	239 (16)	881
	<hr/> 1429	<hr/> 1532	<hr/> 2476

U. S. BUREAU OF MINES DATA

RBHH

6/81

TANTALUM and TANTALUM ALLOY MILL PRODUCTS

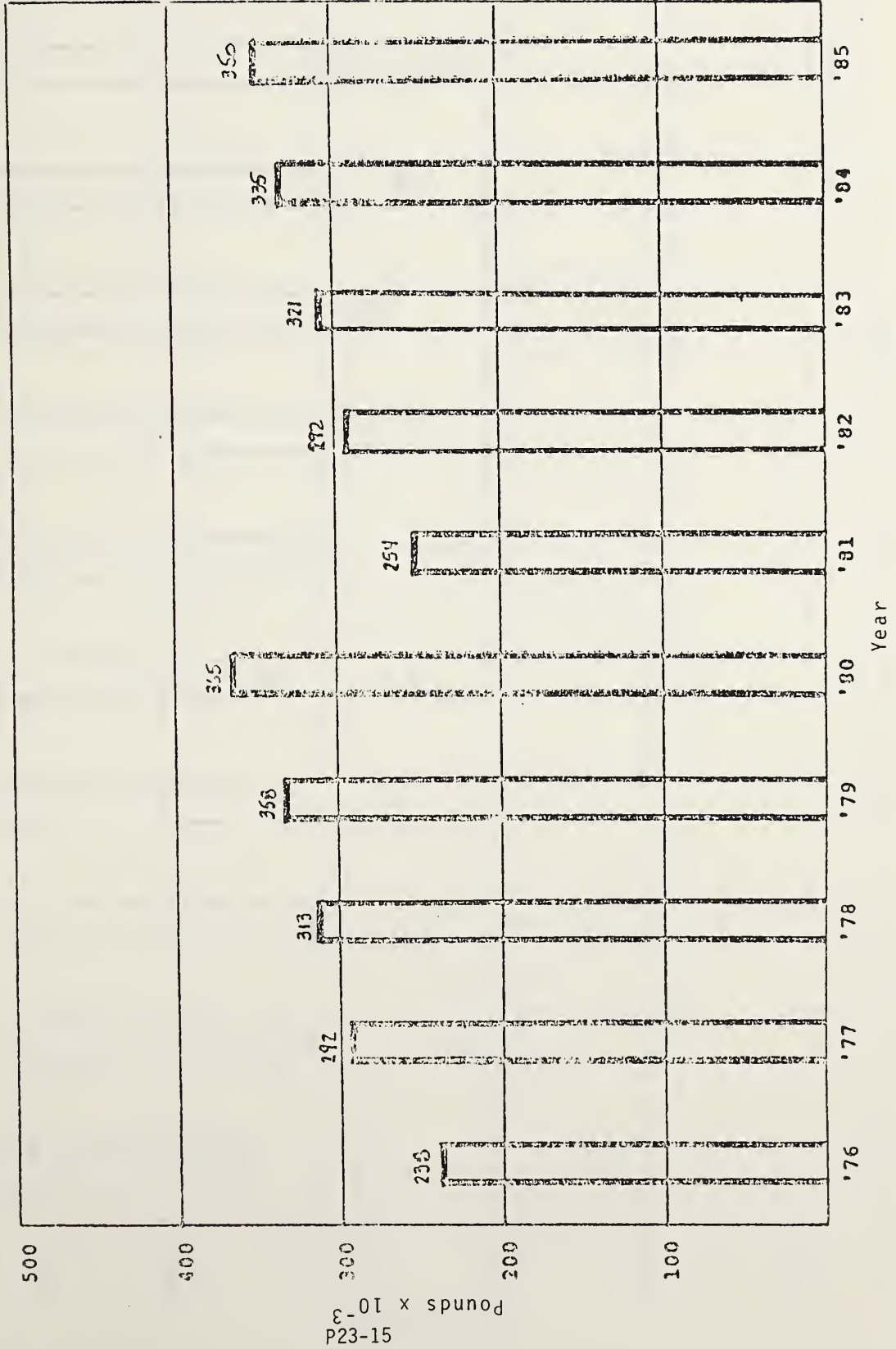

Producer Report Data

TANTALUM Recycle Material (Ta additions for high temperature alloys)

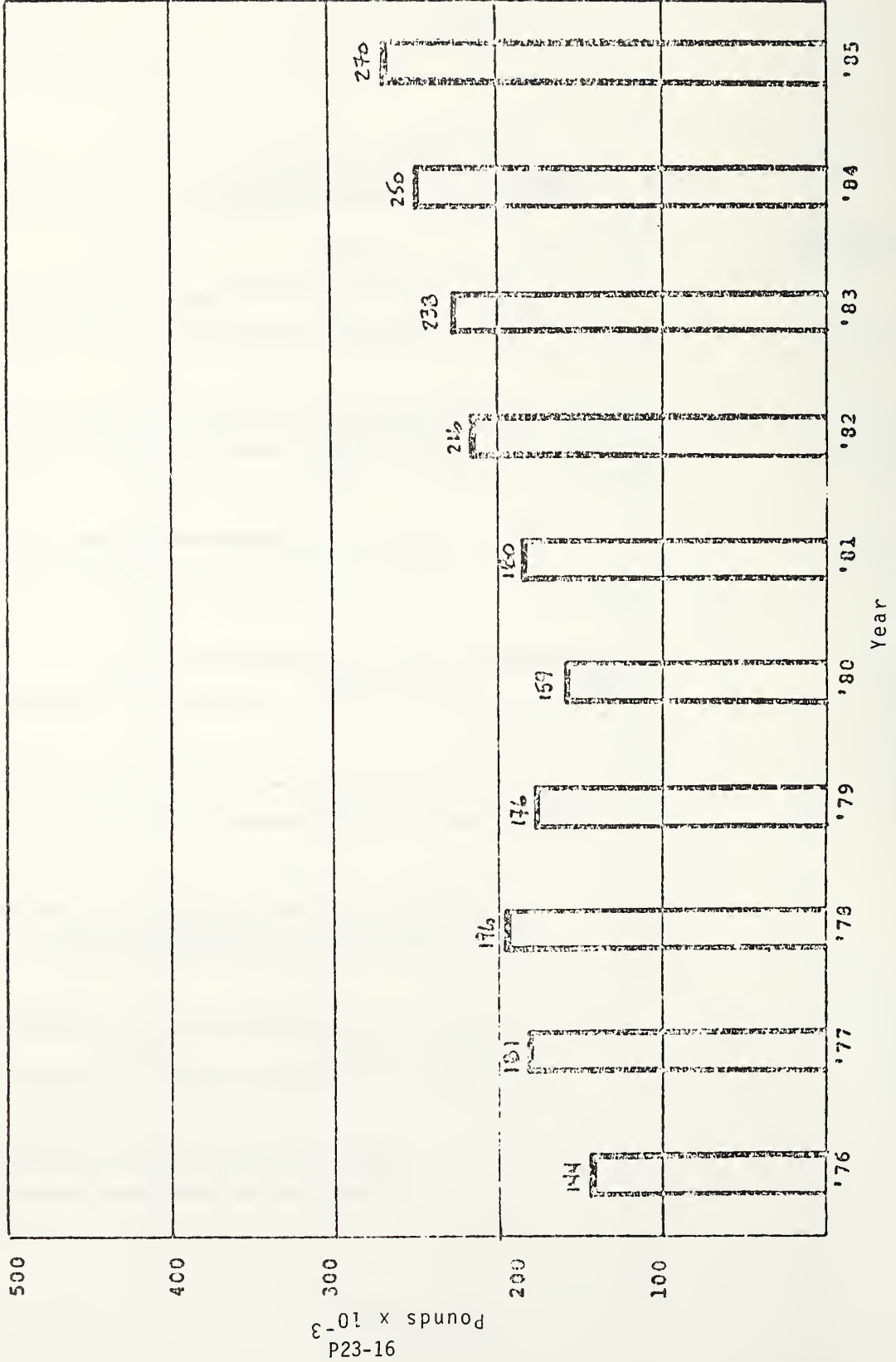

Slide 5

TOTAL TANTALUM (Mill Products + Ta Remelt)

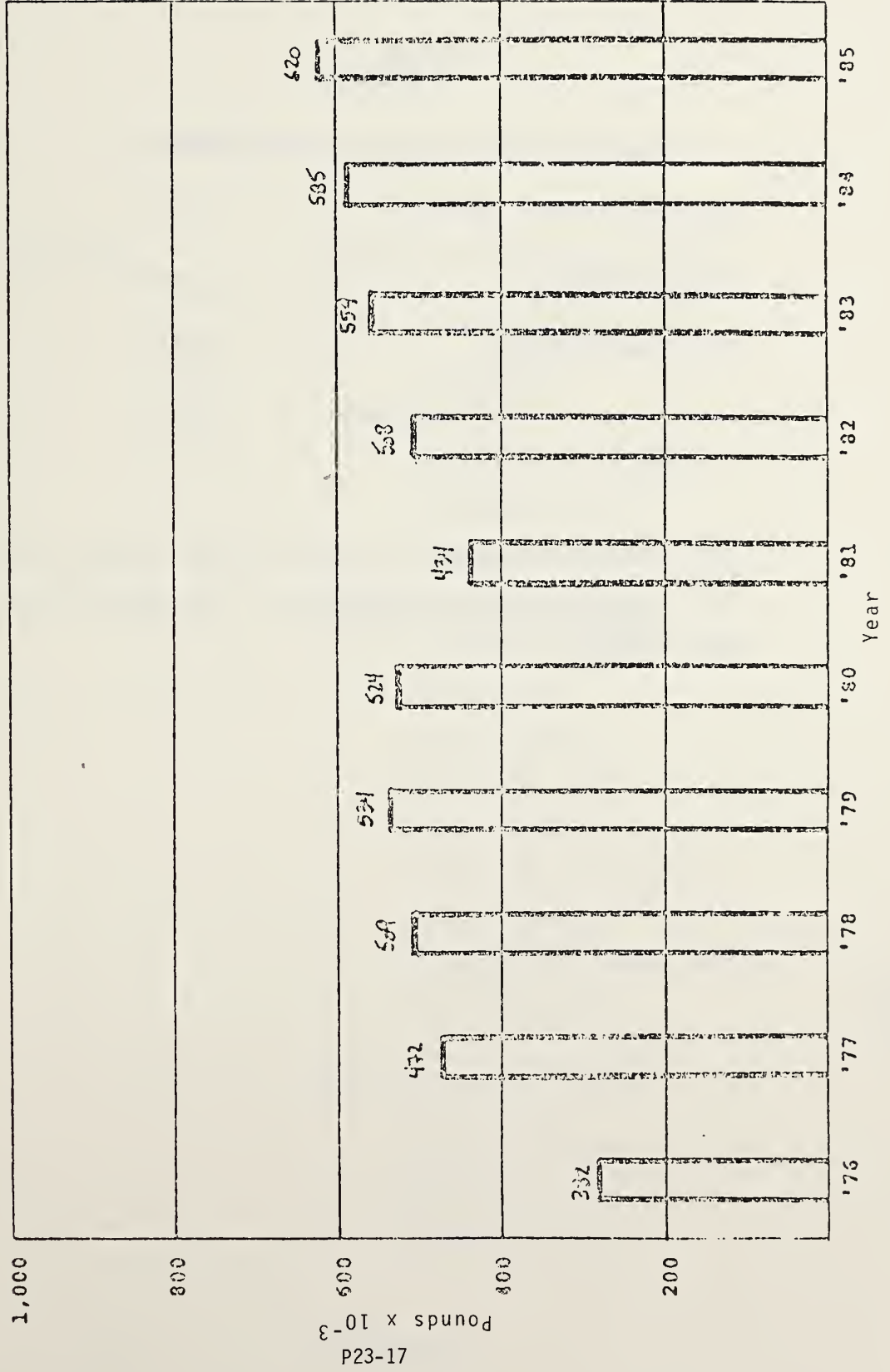

SLIDE 6

	<u>1000 LBS.</u>	<u>PERCENT</u>
TANTALUM AND MILL PRODUCTS	365	26.5
TANTALUM REMELT	159	11.5
CAPACITOR POWDERS	853	61.9
TOTAL	<u>1377</u>	<u>99.9</u>

NOTE: ASSUMING 2.5 W/O TA CONTENT FOR THE AVERAGE CONTENT OF A TANTALUM-CONTAINING SUPERALLOY, THIS MEANS 6,360,000 POUNDS WERE PRODUCED IN 1980.

RBHH

6/81

SLIDE 7

TANTALUM AND TANTALUM ALLOY PRODUCTS

PURE METAL:

EQUIPMENT FOR CHEMICAL INDUSTRY

HEAT EXCHANGERS

CONDENSERS

HEATERS

DISTILLATION COLUMNS

REACTION VESSELS

HARDWARE

ELECTRICAL & ELECTRONICS

CAPACITORS

HALOGEN LAMPS

INFRA-RED LAMPS

POWER SOURCES

LITHIUM BATTERY SEALS

X-RAY HARDWARE

CATHODIC PROTECTION SYSTEMS

VAPOR DEPOSITION

HIGH TEMPERATURE FURNACES

HEATING ELEMENTS

SHIELDS

SUPPORT HARDWARE

SLIDE 7 (CONT.)

TA-2-1/2%W ALLOY

EQUIPMENT FOR CHEMICAL INDUSTRY

SAME APPLICATIONS AS PURE METAL

ELECTRICAL & ELECTRONICS

X-RAY HARDWARE

HIGH TEMPERATURE FURNACES

SAME AS PURE METAL

TA-90%W ALLOY

HIGH TEMPERATURE FURNACES

SAME AS PURE METAL

AEROSPACE

RBHH

6/81

SLIDE 8

RELATIVE COST OF MATERIALS*

	<u>DOLLARS/POUND</u>
TANTALUM	85
HAFNIUM	85
COLUMBIUM	25
ZIRCONIUM	12
TITANIUM	7.25
VANADIUM	4.60

* SPONGE OR HIGH GRADE SCRAP

RBHH

6/81

Slide 9

SUPERALLOYS CONTAINING TANTALUM

<u>Alloy Designation</u>	<u>Ni</u>	<u>Cr</u>	<u>Co</u>	<u>Mo</u>	<u>W</u>	<u>Ta</u>	<u>Cb</u>	<u>Al</u>	<u>Ti</u>	<u>C</u>	<u>B</u>	<u>Zr</u>	<u>Other</u>
Nickel-Base (Cast)													
*B-1900	64	8	10	6	-	4	-	6	1	0.1	0.015	0.10	
*B-1900+Hf	63	8	10	6	-	4	-	6	1	0.1	0.015	0.10	1 Hf
PWA 454	62	10	5	-	4	12	-	5	1.5	-	-	-	
IN 162	73	10	-	4	2	2	1	6.5	1	0.12	0.02	0.1	
*IN 738	61	16	8.5	1.7	2.6	1.7	0.9	3.4	3.4	0.17	0.01	0.1	
*IN 792	61	12.4	9	1.9	3.8	3.9	-	3.1	4.5	0.12	0.02	0.1	
M22	71	5.7	-	2.0	11.0	3.0	-	6.3	-	0.13	-	0.6	
MAR-M-246	60	9	10	2.5	10	1.5	-	5.5	1.5	0.15	0.015	0.05	
*MAR-M-247	60	8.2	10	0.6	10	3	-	5.5	1.0	0.16	0.02	0.09	1.5Hf
MAR-M-432	50	15.5	20	-	3	2	2	2.8	4.3	0.15	0.015	0.05	
TAZ 8A	68	6	-	4	4	8	2.5	6	-	0.12	0.004	1	
TAZ 8B (DS)	64	6	5	4	4	8	1.5	6	-	0.12	0.004	1	
TRW-NASA VIA	61	6.1	7.5	2	5.8	9	0.5	5.4	1.0	0.13	0.02	0.13	0.5Re, .4Hf

* Highest commercial application

RBHH
6/81

Slide 9 (Cont.)

SUPERALLOYS CONTAINING TANTALUM

<u>Alloy Designation</u>	<u>Ni</u>	<u>Cr</u>	<u>Co</u>	<u>Mo</u>	<u>W</u>	<u>Ta</u>	<u>Cb</u>	<u>Al</u>	<u>Ti</u>	<u>C</u>	<u>B</u>	<u>Zr</u>	<u>Other</u>
Cobalt-Base (Cast)													
HAYNES 1002	16	22	Bal	-	7	3.8	-	0.2	0.2	0.6	-	0.3	1.5Fe, 0.7Mn 0.4Si, 0.05L
MAR-M-302	-	22	58	-	10	9	-	-	-	0.85	0.005	0.2	
*MAR-M-509	10	23.5	55	-	7	3.5	-	-	0.2	0.6	-	0.5	
<u>Nickel and Iron Base Wrought</u>													
*HAYNES alloy 556	20	22	18	3	2.5	0.9	0.1	0.3	-	0.1	Bal Fe, 1.5Mn, 0.4Si, 0.02La		
AF2-IDA	59	12	10	3	6	1.5	-	4.6	3	0.35	0.014	0.1	1Fe

* Highest commercial application

SLIDE 10

BENEFITS AND PENALTIES OF
TANTALUM IN SUPERALLOYS

BENEFITS:

IMPROVED STRENGTH
(PERHAPS DOUBLE)

IMPROVED SURFACE INTEGRITY
(.5 TO .1 CORROSION RATE)

ENHANCED METALLURGICAL STABILITY
(70%+ RETAINED DUCTILITY)

PENALTIES:

COST (\$4-12/LB. OF METAL)

INCREASED DENSITY (UP TO 10%)

RBHH

6/81

SLIDE 21

CORROSION RATES (MILS PER YEAR)

	<u>CB</u>	<u>TA</u>	<u>II</u>	<u>ZR</u>	<u>C-276</u>	<u>B-2</u>	<u>304/316</u>
10% HCL (BOILING)	0.2	NIL	6672	0.3	228	7	91.080
40% H2SO4 (50°C)	0.2	NIL	586	NIL	0.7	0.1	246.000
10% HNO3 (BOILING)	NIL	NIL	-	NIL	17	19,309	2
10% (NAOH) (R.T.)	0.7	0.4	0.6	NIL	NIL	NIL	NIL
40% KOH (R.T.)	4	15	NIL	NIL	NIL	NIL	NIL
10% HCOOH (BOILING) (FORMIC)	NIL	NIL	128	NIL	3	0.2	8
10% HOCOCOOH (BOILING) (OXALIC)	0.9	NIL	3857	NIL	4	-	222

Slide 11

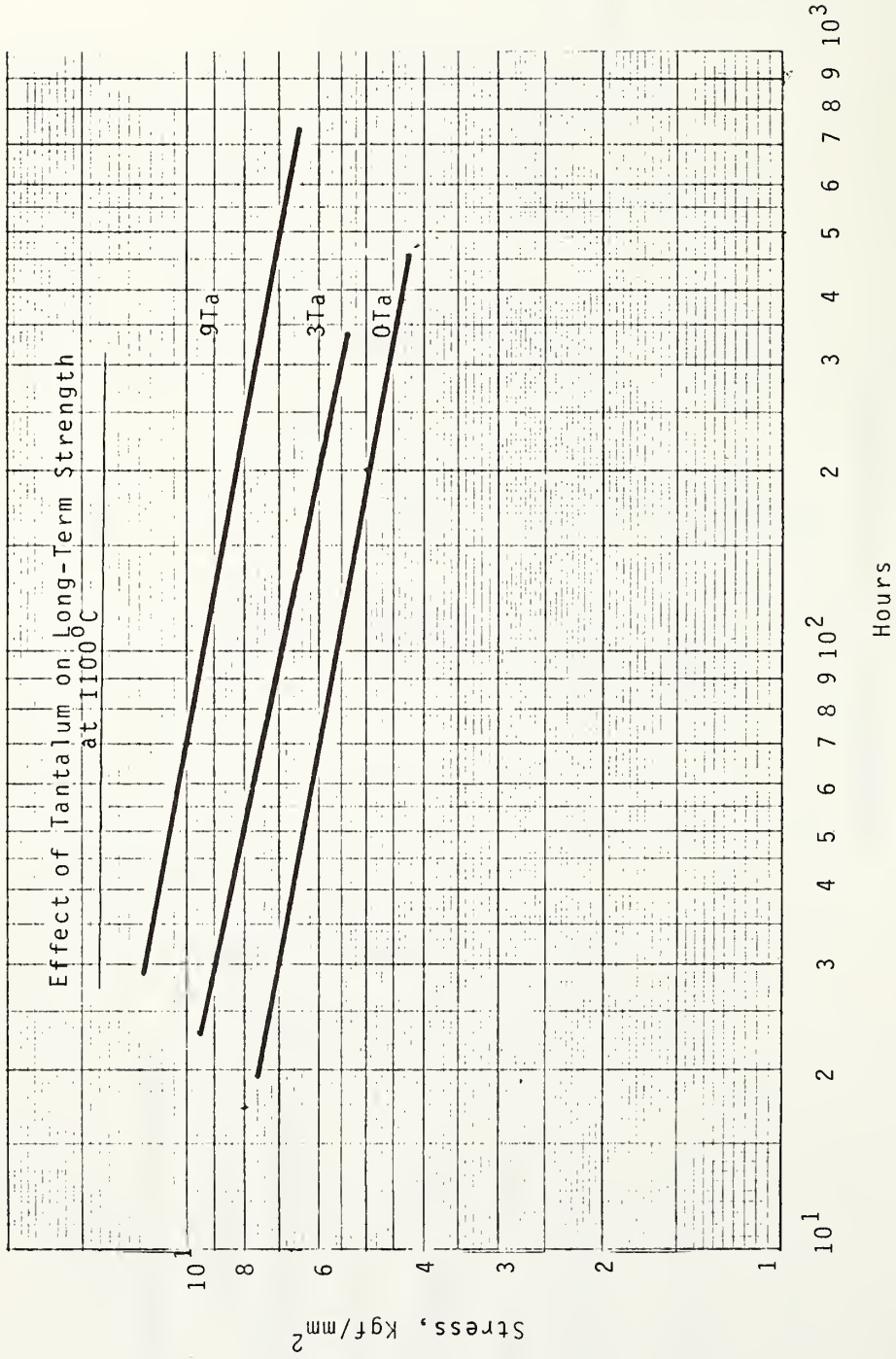

After N. N. Buroya and
S. B. Maslennykov

SLIDE 12

REASONS FOR TANTALUM BENEFITS

SOLID SOLUTION STRENGTHENING

CARBIDE STABILITY

CARBIDE MORPHOLOGY

GAMMA PRIME STABILITY CONSTITUTION AND
MORPHOLOGY

LESS FRECKLING

BENEFICIAL OR NEUTRAL EFFECTS ON CORROSION

RBHH

6/81

SLIDE 13

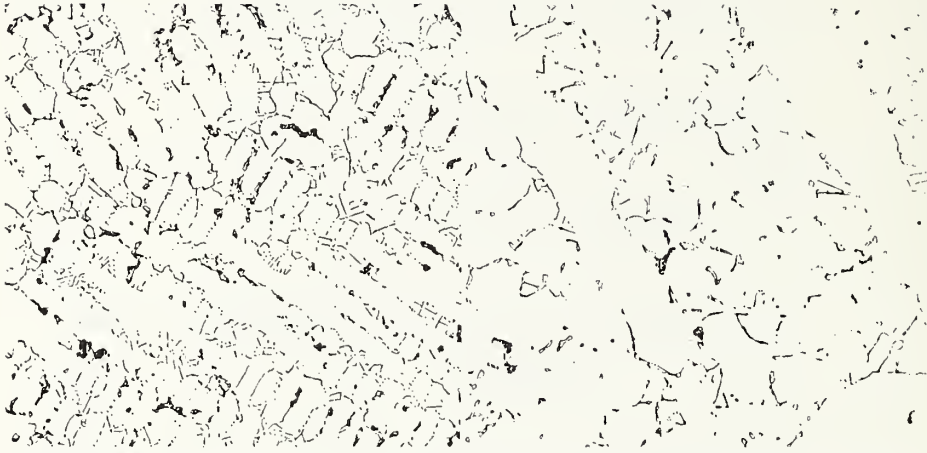

Kalling's reagent

100x

1590 MAR-M 509, as cast. The structure consists of MC particles in script form and M₂C₃ particles in eutectic form (gray areas) and precipitate form in the dendritic alpha solid-solution matrix (face-centered cubic).

Electrolytic: 5% phosphoric acid

500x

1591 Same as 1591, but at a higher magnification, to reveal morphology of MC script particles, primary eutectic particles (M₂C₃), and precipitated M₂C₃ (shadowy constituent) in the alpha (fcc) matrix.

SLIDE 14

NITAC EUTECTICS²

(6-11 TA .04C + Co, CR, AL, V)

1. OXIDATION RESISTANCE COMPARABLE TO R80.
2. OPERATION ~ 250°F HIGHER TEMPERATURE RESULTS
IN 1% INCREASE IN FUEL COUPLED WITH 17% INCREASE
IN THRUST.
3. NOMINALLY 1 MICRON WHISKER ORIENTED ALONG
LONGITUDINAL AXIS.
4. REPORTEDLY AS MUCH AS 20 LONGER LIFE IN LOW
CYCLE FATIGUE.
5. 30% HIGHER ENDURANCE STRESS AT HIGH CYCLE FATIGUE.
6. RESEARCHERS ARE REPORTED TO BE EVALUATING
Cb, CR, AND Mo WITHOUT APPRECIABLE SUCCESS.

RBHH

6/81

SLIDE 15

THERMODYNAMIC PREDICTION OF STABILITY

	<u>$\Delta G_R - \text{CAL.}$</u>
$\text{HF} + \text{C} \rightarrow \text{HFC}$	-52723
$\text{ZR} + \text{C} \rightarrow \text{ZRC}$	-43895
$\text{TI} + \text{C} \rightarrow \text{TIC}$	-40088
$\text{TA} + \text{C} \rightarrow \text{TAC}$	-33610
$\text{NB} + \text{C} \rightarrow \text{NBC}$	-32707
$\text{V} + \text{C} \rightarrow \text{VC}$	-21335
$\text{W} + \text{C} \rightarrow \text{WC}$	-8310

EMPIRICALLY ORDER OF FORMATION

HFC, ZRC, TAC, CBC, TIC, VC, WC

RBHH

6/81

SLIDE 16

MC TYPICALLY NOT PURE, I.E., TIC, TAC, ETC., WITH OTHER "M" ATOMS SUBSTITUTING FOR ONE ANOTHER.

EXAMPLE:

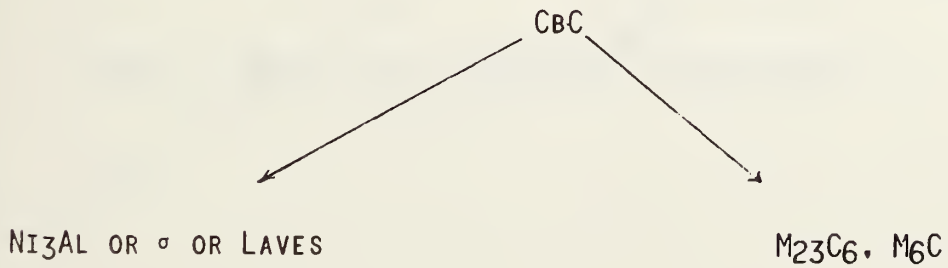
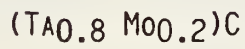

RBHH

6/81

SLIDE 17

IMPROVED CASTABILITY⁵

STEVE COPLEY, ET. AL., REPORTS TANTALUM SIGNIFICANTLY
REDUCES TENDENCY OF "FRECKLING" IN CASTINGS.

METALLURGICAL TRANSACTION, VOL. 1, No. 8, 1970.

RBHH

6/81

Slide 1818

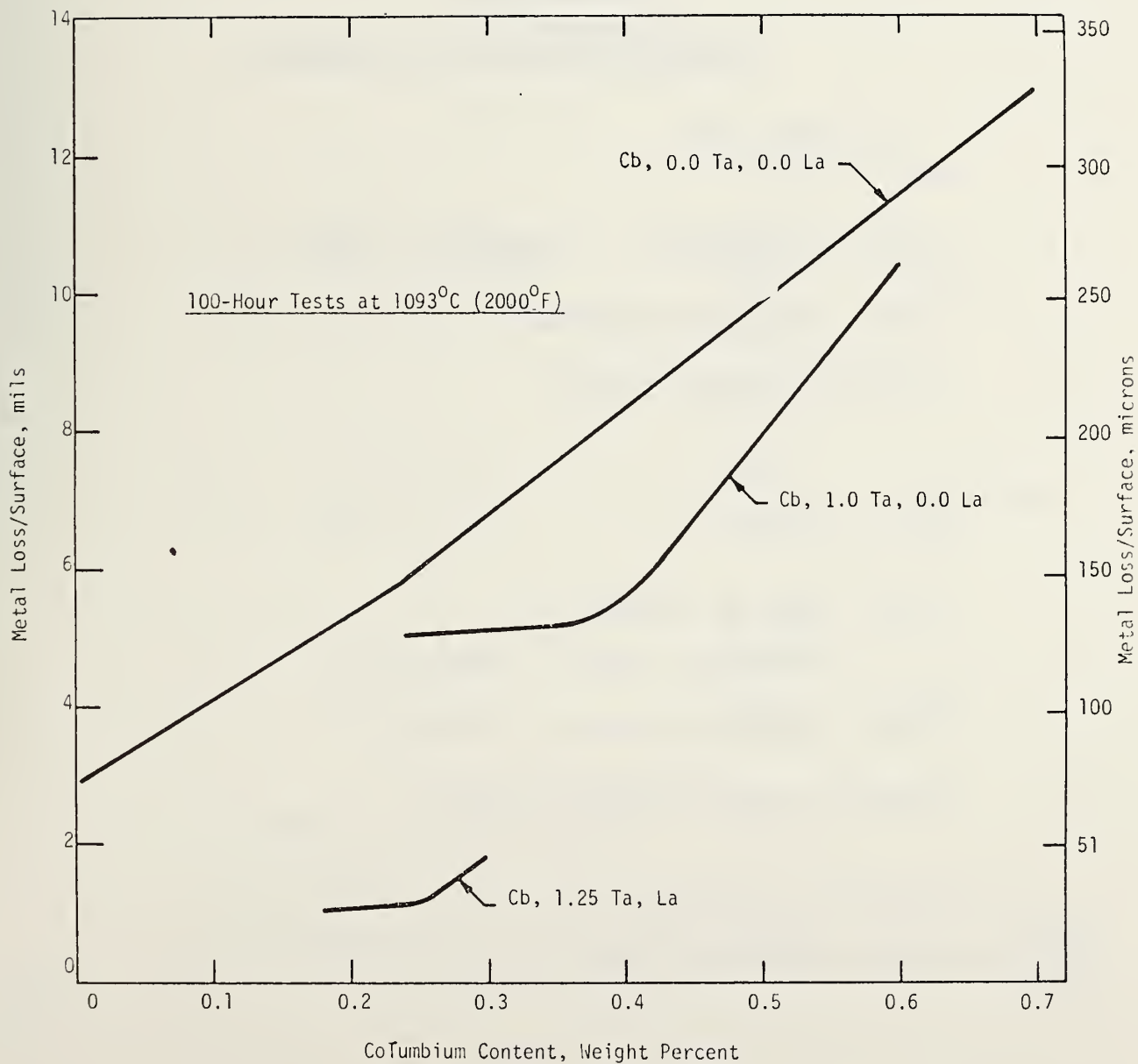

DYNAMIC OXIDATION DATA VS COLUMBIUM CONTENT

SLIDE 19

TANTALUM INFLUENCE ON HOT CORROSION⁶

CASE I - No TA



Na_2MoO_4 DISSOLVED Al_2O_3 SCALE

SUBSTRATE CORRODES SEVERELY

CASE II - 9 TA

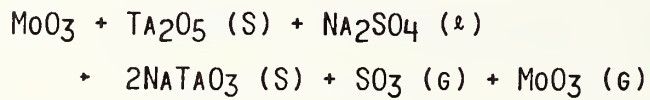

NATAO_3 IS SOLID AND DOES NOT FLUX Al_2O_3

SUBSTRATE REMAINS PROTECTED BY Al_2O_3

RBHH

6/81

SLIDE 20
ELECTROCHEMISTRY

STD. OXID. POT.

CB	+	$CB^{+++} + 3E^{-}$	+1.10V	
TA	+	$TA^{+++++} + 5E^{-}$	+0.85V	ACTIVE
CB	+	$CB^{+++++} + 5E^{-}$	+0.65V	
NI	+	$NI^{++} + 2E^{-}$	+0.25V	
MO	+	$MO^{+++} + 3E^{-}$	+0.20V	LESS ACTIVE
PD	+	$PD^{++} + 2E^{-}$	-0.98V	
AU	+	$AU^{+++} + 3E^{-}$	-1.50V	NOBLE

IN THEORY TA IS QUITE ACTIVE!

IT IS PRESUMABLY THE SPECIAL PROPERTIES OF "AMORPHOUS" FILM THAT PROVIDES EXCELLENT CORROSION RESISTANCE THROUGH PASSIVITY.

RBHH

6/81

SLIDE 22

TRADEMARKS

MAR-M	MARTIN MARIETTA CORPORATION
HAYNES	CABOT CORPORATION
HASTELLOY	CABOT CORPORATION
MULTIMET	CABOT CORPORATION
INCONEL	INCO FAMILY OF COMPANIES
INCOLOY	INCO FAMILY OF COMPANIES
RENE'	GENERAL ELECTRIC COMPANY
UDIMET	SPECIAL METALS CORPORATION
UNITEMP	UNIVERSAL CYCLOPS CORPORATION

RBHH

6/81

PARTITIONING IN TRW VIA ALLOY¹

	<u>C</u>	<u>CR</u>	<u>CO</u>	<u>MO</u>	<u>W</u>	<u>CB</u>	<u>TI</u>	<u>AL</u>	<u>IA</u>	<u>ZR</u>
ALLOY	.13	6	7.5	2	6	0.5	1.0	3.4	9.0	0.15
GAMMA PRIME	-	3.6	7.0	1.7	3.2	0.1	0.6	11.5	11.0	-

HE B

ALLOY 0.5 0.02

GAMMA PRIME 0.3 -

RBHH
6/81

U.S. DEPT. OF COMM. BIBLIOGRAPHIC DATA SHEET <i>(See instructions)</i>	1. PUBLICATION OR REPORT NO. NBSIR 82-2495	2. Performing Organ. Report No.	3. Publication Date April 1982
4. TITLE AND SUBTITLE CONSERVATION AND SUBSTITUTION TECHNOLOGY FOR CRITICAL MATERIALS--Proceedings of Public Workshop sponsored by U.S. Department of Commerce/National Bureau of Standards and U.S. Department of Interior/Bureau of Mines. VOLUME I.			
5. AUTHOR(S) Allen G. Gray			
6. PERFORMING ORGANIZATION <i>(If joint or other than NBS, see instructions)</i> NATIONAL BUREAU OF STANDARDS DEPARTMENT OF COMMERCE WASHINGTON, D.C. 20234		7. Contract/Grant No.	8. Type of Report & Period Covered
9. SPONSORING ORGANIZATION NAME AND COMPLETE ADDRESS <i>(Street, City, State, ZIP)</i> Department of Commerce Department of the Interior National Bureau of Standards and Bureau of Mines Washington, DC 20234 Washington, DC 20241			
10. SUPPLEMENTARY NOTES <input type="checkbox"/> Document describes a computer program; SF-185, FIPS Software Summary, is attached.			
11. ABSTRACT <i>(A 200-word or less factual summary of most significant information. If document includes a significant bibliography or literature survey, mention it here)</i> The United States is highly vulnerable to problems in supply of critical and strategic materials and it is recognized that there is a whole spectrum of options for responding to such crises. While a number of supply oriented options are under study by various groups, the focus of this Workshop was on the technical options. The Workshop was held principally to develop information for the report required by the Department of Commerce, but should also be useful to the other agencies in their responsibilities. The DoC report is supposed to identify a materials needs case related to national security, economic well-being, and industrial productivity, to assess critical materials needs, and to recommend programs to meet these needs.			
12. KEY WORDS <i>(Six to twelve entries; alphabetical order; capitalize only proper names; and separate key words by semicolons)</i> Critical materials; strategic materials; conservation; substitution; chromium; cobalt; titanium; tantalum.			
13. AVAILABILITY <input checked="" type="checkbox"/> Unlimited <input type="checkbox"/> For Official Distribution. Do Not Release to NTIS <input type="checkbox"/> Order From Superintendent of Documents, U.S. Government Printing Office, Washington, D.C. 20402. <input checked="" type="checkbox"/> Order From National Technical Information Service (NTIS), Springfield, VA. 22161		14. NO. OF PRINTED PAGES 488	15. Price \$34.50

