



A11103 430440

Reference

NIST
PUBLICATIONS

FILE COPY
DO NOT TAKE

NBSIR 81-2324 (R)

Boiling Tests of Non-Asbestos-Based Thermal Insulation Used in Air-Conduit Underground Heat Distribution Systems

U.S. DEPARTMENT OF COMMERCE
National Bureau of Standards
National Engineering Laboratory
Center for Building Technology
Washington, DC 20234

September 1981

Prepared for:
Naval Facilities Engineering Command
U.S. Navy
Washington, DC 20390

Directorate of Civil Engineering
U.S. Air Force
Washington, DC 20330

Office of Chief of Engineers

ny
ton, DC 20314

QC

100

456

81-2324

1981



NBSIR
DC 100
USG
81-2324
1981

NBSIR 81-2324

**BOILING TESTS OF NON-ASBESTOS-BASED
THERMAL INSULATION USED IN AIR-CONDUIT
UNDERGROUND HEAT DISTRIBUTION SYSTEMS**

T. Kusuda
W. M. Ellis

U.S. DEPARTMENT OF COMMERCE
National Bureau of Standards
National Engineering Laboratory
Center for Building Technology
Washington, DC 20234

September 1981

Prepared for:
Naval Facilities Engineering Command
U.S. Navy
Washington, DC 20390

Directorate of Civil Engineering
U.S. Air Force
Washington, DC 20330

Office of Chief of Engineers
U.S. Army
Washington, DC 20314



U.S. DEPARTMENT OF COMMERCE, Malcolm Baldrige, *Secretary*
NATIONAL BUREAU OF STANDARDS, Ernest Ambler, *Director*



ABSTRACT

Non-asbestos-based thermal insulation around steam carrier pipes is commonly used in conduit underground heat distribution systems for many of the Tri-service installations. When the conduit fails, the insulation is expected to undergo severe boiling action due to the possible ingress of underground water. If the insulation is properly fabricated, it should withstand the prolonged boiling such that its thermal performance would be restored when the ground water is drained and the system dried.

Several selected insulation systems were boiled in an open tank as well as in the conduit to test their ability for retaining the original insulation capability.

Although most of the calcium silicate-based insulation systems fell off the carrier pipe under the open tank boiling within 72 hours, they were able to withstand 96 hours of continuous boiling in the conduit. When drained and dried, these systems restored their thermal insulation performance to within 10 percent of the original value.

Key words: boiling test; conduit system; pipes; thermal insulation; underground heat distribution systems.

PREFACE

This report summarizes the test results of open-tank and in-conduit boiling tests on non-asbestos-based thermal insulation used in the Tri-Service-type air-conduit underground heat distribution systems. Systems of several selected manufacturers were listed at the request of the Tri-Service committee on underground heat distribution systems since 1976, results of which have been reported in seven successive NBS Letter Reports, as listed below.

Boiling test of calcium silicate insulation for underground heat distribution systems.

Conduit boiling test of the insulation in underground heat distribution systems.

- Part I : Kaylo System
- Part II : Thermo-12 System
- Part III: Pabco System
- Part IV : Wesolite System
- Part V : Eagle-Picher System
- Part VI : Celotemp-1500 System

Also included in this summary report are the results of the last series of tests, where the conduit boiling continued up to 64 days.

Commercial names are used in this report to identify for the sponsor the specific materials tested. Such identification does not imply recommendation or endorsement by the National Bureau of Standards, nor does it imply that the materials or equipment identified are necessarily the best available for the purpose.

TABLE OF CONTENTS

	<u>Page</u>
1. OPEN TANK BOILING TEST	1
1.1 Introduction	1
1.2 Boiling Test Apparatus	2
1.3 Open-Tank Boiling Tests	2
1.3.1 Kaylo Insulation	2
1.3.2 Pabco Super Caltemp Insulation	3
1.3.3 J-M Thermo-12 Insulation	3
1.4 Summary of the Open Tank Boiling Test	4
2. CONDUIT BOILING TEST	30
2.1 Introduction	30
2.2 Description of Test Apparatus	30
2.3 Test Procedure	38
2.4 Tri-Service Evaluation Criteria	39
2.5 Test Results	40
2.5.1 Kaylo-10 System	40
2.5.2 Thermo-12 System	40
2.5.3 Pabco System	48
2.5.4 Wesolite System	55
2.5.5 Epitherm System	55
2.5.6 Celotemp System	64
3. SIXTY-FOUR-DAY CONDUIT BOILING TEST	73
4. COMPARISON WITH CALCULATED PIPE HEAT TRANSFER FACTORS	101
5. REFERENCES	105

LIST OF TABLES

	<u>Page</u>
Table 1. Sixty-four-day Conduit Boiling Test of Six Insulation Materials	74
Table 2. Comparison Between the Calculated and Measured Heat Transfer Factor C	104

LIST OF FIGURES

Figure 1. A schematic of the open-tank boiling test apparatus	5
Figure 2. KAYLO #1 system before the boiling	6
Figure 3. Pipe side view of KAYLO #1 specimen before boiling	7
Figure 4. Conduit side view of KAYLO #1 specimen before boiling	8
Figure 5. KAYLO #1 system after 5 hours boiling	9
Figure 6. KAYLO #2 specimen before boiling	10
Figure 7. Conduit side view of KAYLO #2 specimen before boiling	11
Figure 8. Pipe side view of KAYLO #2 specimen before boiling	12
Figure 9. KAYLO #2 system after 72 hours boiling and 24 hours drying ...	13
Figure 10. KAYLO #2 after 72 hours boiling and 24 hours drying	14
Figure 11. PABCO #1 system before boiling	15
Figure 12. A close-up of PABCO #1 system before boiling	16
Figure 13. Conduit side view of PABCO #1 specimen	17
Figure 14. Pipe side view of PABCO #1 specimen	18
Figure 15. PABCO #1 system after 1 hour boiling	19
Figure 16. PABCO #2 system before the boiling	20
Figure 17. Conduit side view of PABCO #2 specimen	21
Figure 18. Pipe side view of PABCO #2 specimen	22
Figure 19. PABCO #2 system after 3 hours boiling	23
Figure 20. A close-up of PABCO #2 system after 3 hours boiling	24
Figure 21. J/M system before the boiling	25
Figure 22. Conduit side view of J/M specimen before boiling	26
Figure 23. Pipe side view of J/M specimen before boiling	27
Figure 24. J/M system after 72 hours boiling and 24 hours drying	28
Figure 25. Close-up of J/M system after 72 hours boiling and 24 hours drying	29
Figure 26. A schematic diagram of conduit boiling test for underground heat distribution system	32
Figure 27. The thermal conditioning box for the conduit boiling test apparatus	33
Figure 28. Baffle plates along the air passage to obtain uniform temperature around the test underground conduit system	34

LIST OF FIGURES (Continued)

Page

Figure 29.	Header plates for the underground conduit insulation boiling tests: one for the electric heating (left) to measure pipe heat loss; the other for the steam heating (right) to provide boiling	35
Figure 30.	Instrumentation and power control panel for the insulation boiling test	36
Figure 31.	Immersion electric heaters for the heat loss test	37
Figure 32.	Heat loss and temperature data during the test for Kaylo-10 insulation	41
Figure 33.	Longitudinal distribution of the conduit surface temperature before and after the Kaylo-10 boiling tests	42
Figure 34.	Kaylo-10 insulation after the boiling tests shows severe erosion due to the boiling action	43
Figure 35.	The joint of Kaylo-10 insulation jacket was eroded out by the boiling action of water outside the carrier pipe	44
Figure 36.	Crumbs of Kaylo-10 insulation found in the conduit space after the carrier pipe and insulation jacket were removed	45
Figure 37.	Heat loss and temperature data during the boiling test of Thermo-12	46
Figure 38.	Longitudinal distribution of the conduit temperature before and after the Thermo-12 boiling test	47
Figure 39.	Thermo-12 insulation removed from the conduit after boiling for 192 hours and drying	49
Figure 40.	The waterline during the conduit boiling of the Thermo-12 system	50
Figure 41.	Heat loss and temperature data during the boiling test of Pabco system	51
Figure 42.	Longitudinal distribution of the conduit surface temperature before and after the Pabco boiling tests	52
Figure 43.	The insulation damage due to 192 hours conduit boiling test and subsequent drying (Pabco System)	53
Figure 44.	The Pabco thermal insulation system immediately after removal from the conduit where it underwent 192 hours boiling and subsequent drying tests	54
Figure 45.	Heat loss and temperature data during the test for Wesolite ...	56
Figure 46.	Longitudinal distribution of the conduit surface temperature before and after the boiling tests for Wesolite system	57
Figure 47.	Wesolite on pipe after removal from conduit after 96 hours of boiling	58
Figure 48.	Close-up of opening at joint after conduit boiling of Wesolite	59
Figure 49.	Wesolite after boiling showing deterioration at the bottom of pipe below the water level	60
Figure 50.	Condition of Wesolite after removal from pipe after boiling ..	61
Figure 51.	Heat loss and temperature data during the test of Epitherm ...	62
Figure 52.	Longitudinal distribution of the conduit surface temperature before and after the boiling test of Epitherm	63

LIST OF FIGURES (Continued)

	<u>Page</u>
Figure 53. Epitherm on pipe after removal from conduit after 96 hours of boiling	65
Figure 54. Close-up of Epitherm at the bottom of the pipe after boiling (below the water level)	66
Figure 55. Close-up of Epitherm at the top of the pipe after boiling (above the water level)	67
Figure 56. Heat loss and temperature data during the test of the Celotemp system	68
Figure 57. Longitudinal distribution of the conduit surface temperature before and after the boiling test (Celotemp system)	69
Figure 58. Insulation on the pipe after removal from conduit after 96 hours of boiling (Celotemp system)	70
Figure 59. Insulation after boiling showing deterioration at the bottom of the pipe below the water level (Celotemp system)	71
Figure 60. Crumbs of insulation found in the conduit space after the carrier pipe and insulation jacket were removed (Celotemp system)	72
Figure 61. Celotemp 1500 after 8 days of boiling	75
Figure 62. Celotemp 1500 after 16 days of boiling	76
Figure 63. Thermo-12 after 16 days of boiling	77
Figure 64. Thermo-12 after 24 days of boiling	78
Figure 65. Thermo-12 after 32 days of boiling	79
Figure 66. Thermo-12 after 64 days of boiling	80
Figure 67. Epitherm 1200 after 8 days of boiling	81
Figure 68. Epitherm 1200 after 16 days of boiling	82
Figure 69. Epitherm 1200 after 24 days of boiling	83
Figure 70. Epitherm 1200 after 32 days of boiling	84
Figure 71. Epitherm 1200 after 64 days of boiling	85
Figure 72. Wesolite "D" after 8 days of boiling	86
Figure 73. Wesolite "D" after 16 days of boiling	87
Figure 74. Wesolite "D" after 24 days of boiling	88
Figure 75. Wesolite "D" after 32 days of boiling	89
Figure 76. Wesolite "D" after 64 days of boiling	90
Figure 77. Super Caltemp after 16 days of boiling	91
Figure 78. Super Caltemp after 24 days of boiling	92
Figure 79. Super Caltemp after 32 days of boiling	93
Figure 80. Super Caltemp after 64 days of boiling	94
Figure 81. Kaylo-10 after 16 days of boiling	95
Figure 82. Kaylo-10 after 24 days of boiling	96
Figure 83. Kaylo-10 after 32 days of boiling	97
Figure 84. Kaylo-10 after 64 days of boiling	98
Figure 85. End view of plywood box used to house the conduit	99
Figure 86. Inside of plywood box showing baffles to regulate air flow ...	100
Figure 87. Cross-sectional view of the Tri-service "air conduit" underground heat distribution system	102

UNIT CONVERSION

The text is written using English units to be consistent with the current U.S. practice in underground heat distribution engineering. The units most frequently appearing in the text have the following conversion multipliers to SI units:

1 inch	0.254 cm
1 ft	0.305 m
1 psig	6.89 kPa above 101.2 kPa
1 Btu/h.ft ² .F	1.728 W/m.K
1 Btu-in/h.ft ² .F	0.144 W/m.K
1 lb/ft ³	16.028 kg/m ³
1 °F	(F-32)/1.8°C

1. OPEN-TANK BOILING TEST

1.1 INTRODUCTION

At the request of Tri-Services* engineers, the Thermal Engineering Section of the National Bureau of Standards conducted laboratory boiling tests on several commercial brands of asbestos-free calcium silicate insulation. Most of the calcium silicate insulations tested over the past few years have satisfied the boiling and drying requirement when the asbestos was used as a binder for the calcium silicate, but because of the recent ban of the use of asbestos material, synthetic fibre type binder is now being used throughout industry. Since some difficulties have been experienced in the field on this new type of insulation material, the Tri-Services requested NBS to conduct the boiling test on the new types of calcium silicate insulation. The purpose of the investigation was to clarify misgivings as to the performance of asbestos-free calcium silicate insulation in the "air conduit system**" when the conduit is flooded, due mostly to the ingress of ground water.

According to the Tri-Services Guide Specification (TS-15P28) the insulation material in the conduit system should withstand the boiling and should be able to assume the pre-boiling thermal resistance value after the ground water is drained off. In order to assure this requirement, the Tri-Services, with the cooperation of NBS, previously developed a laboratory boiling test procedure for the acceptance of the conduit system insulation. [Specification for Heat-Distribution System, March 24, 1958]. The Tri-Service/NBS test procedure is summarized as follows:

The test insulation specimen is installed around 4-inch pipe immersed in a water tank with the top of the insulation being 2 inches below the water surface. The insulation is then boiled for 72 hours by maintaining 125 psig of steam in the pipe.

If portions of the insulation fall off of the pipe, if the insulation becomes eccentric at the center lines of the pipe, if the longitudinal or circumferential joints open up significantly, or if cracks or ruptures occur in the insulation wide enough that the pipe surface can be seen, the insulation will have failed the test.

When the pipe insulation withstands the boiling test, the tank will be drained and the wet insulation will be dried with steam at 350° (125 psig) for 24 hours. A representative cross section of the insulation will be taken and put into an oven at 215°F until its weight becomes constant.

* TRI-Services represent Naval Facilities Engineering Command; Directorate of Civil Engineering, U.S. Air Force; and Office of Chief of Engineers, U.S. Army.

** The "air conduit system" is one of the Tri-service approved underground heat distribution pipe systems whereby thermal insulation around the carrier pipe is protected by a metallic conduit with an airspace.

Three commercial types of calcium silicate insulation were tested in this investigation: Owens-Corning "Kaylo," Pabco "Super Caltemp," and Johns-Manville "J-M Thermo-12."

1.2 BOILING TEST APPARATUS

Since the original boiling test facility constructed in 1961 at the old NBS site in Washington, D.C. was no longer available at the present Gaithersburg campus, a new facility was built, and is shown in figure 1 with the following components being identified:

A steel tank (1), 10 ft long, 20 in wide, 24 in deep, 1/2 in thick, is mounted on dolly wheels with a drain in the bottom and with fill and overflow connections on one end. A constant water level float assembly (2) was used during the test. A piece of 8-ft long, 4-in pipe (3) was installed inside of the tank. The 125 psig steam is supplied to this pipe through the 1-in diameter line (4). Also installed onto this 4-in pipe are a 1/2-in vent line (5) at the outlet end of the pipe, and a pressure gage (6) at the inlet end. Two condensate traps (7), (8) were used on the outlet of the steam pipe; one small trap (7) is for use when the tank was not filled with water (or when the insulation is not boiling), and a larger trap (8) is for use when the tank was filled with water (or when the insulation is boiling). Another condensate trap (9) was used at the inlet of the steam supply to the 4-in test pipe in order to supply dry steam to the test pipe.

The three condensate lines from these traps (7), (8), and (9) were separately introduced into the condensate cooler (10) by coiled copper tubings. Cold tap water was used as a coolant. A platform scale (13) was used to weigh the amount of condensate during testing of insulation. Water from the condensate cooler, the condensate collection can (11), and overflow from the boiling tank was dumped into the floor drain inside of Building 226. The sump pump (12) was used when the gravity drains for condensate collection (11) would not take care of all of the condensate and cooling water.

In addition, copper constantan thermocouples were used to measure the pipe surface temperature, insulation surface temperature, tank water temperature, and ambient air temperature.

1.3 OPEN-TANK BOILING TESTS

1.3.1 Kaylo Insulation

Two Owens-Corning "Kaylo" specimens were tested in the first test -- the insulation was tied onto the 4-in pipe with 16-ga. bare copper wire on 9-in centers, as shown in figure 2. A one-half-section piece is shown (both sides) in figures 3 and 4, and figure 5 shows the results after 5 hours of boiling. This insulation started to crack off of the pipe after about 30 minutes of

boiling. The density of this batch of insulation was 13.58 lb/ft³ and had a moisture content* of 6.3 percent.

The second test specimen of "Kaylo" insulation was installed on the 4-in pipe with 32-ga. stainless steel straps 1/2 in wide on 9-in centers, as shown in figure 6. One half section is shown (both sides) in figures 7 and 8. The result of 72 hours boiling and 24 hours drying is shown in figures 9 and 10. The top section of the center piece was about 60 percent off of the pipe, the bottom section was broken, and the straps had cut into the insulation as shown. The piece at the trap end of the pipe was broken, but did not fall off of the pipe. The density of the second batch of insulation was 13.69 lb/ft³ and the moisture content was 6.9 percent.

Representatives of Owens-Corning witnessed the installation of the second insulation test specimen to confirm that the installation procedure used in the test was the same as that used in the actual application.

1.3.2 Pabco Super Caltemp Insulation

For the first test with Pabco insulation, 1/2-in wide stainless steel bands, were strapped around the pipe on 18-in centers, as shown in figures 11 and 12. One half section piece (both sides) is shown in figures 13 and 14. This insulation started to break off of the pipe after approximately 20 minutes of boiling and all of it came off within one hour. The results are shown in figure 15. The density of this insulation was 13.79 lb/ft³ and the moisture content was 5.9 percent.

The second test of Pabco insulation was conducted with the insulation installed on the 4-in pipe with 32-ga. stainless steel straps 1/2 in wide on 9-in centers instead of 18 inch, as shown in figure 16. One half section (both sides) is shown in figures 17 and 18. The results of 3 hours boiling are shown in figures 19 and 20. The density of this insulation was 14.40 lb/ft³ and the moisture content was 3.4 percent.

1.3.3 J-M Thermo-12 Insulation

The insulation specimen tested came with canvas covering, which was removed before the test. This insulation was installed on the pipe with 32-ga. stainless steel straps 1/2-in wide on 9-in centers, as shown in figure 21. One half section piece is shown (both sides) in figures 22 and 23. The results of 72 hours of boiling and 24 hours of drying after the water was drained from the tank are shown in figures 24 and 25. Figure 24 shows that the straps have cut into the insulation about 1/2 in or more. Figure 25 shows a closeup of a crack of approximately 5/16-in width in the inlet end piece of insulation. The straps cut into the insulation. All of the individual pieces of the insulation remained intact after testing, with only one section broken. The density of the insulation was 13.31 lb/ft³ and the moisture content was 3.0 percent.

* Throughout the text, the "moisture content" is defined as amount of moisture percent of the dry weight material.

1.4 SUMMARY OF THE OPEN TANK BOILING TEST

All three of the commercial asbestos-free calcium silicate thermal insulations for the underground heat distribution system tested for this investigation failed during the boiling test in the open tank.

The Tri-Services Committee evaluated the test results and determined that the open tank boiling is probably too severe, and advised NBS to repeat the boiling test inside the conduit.

NBS INSULATION BOILING TEST

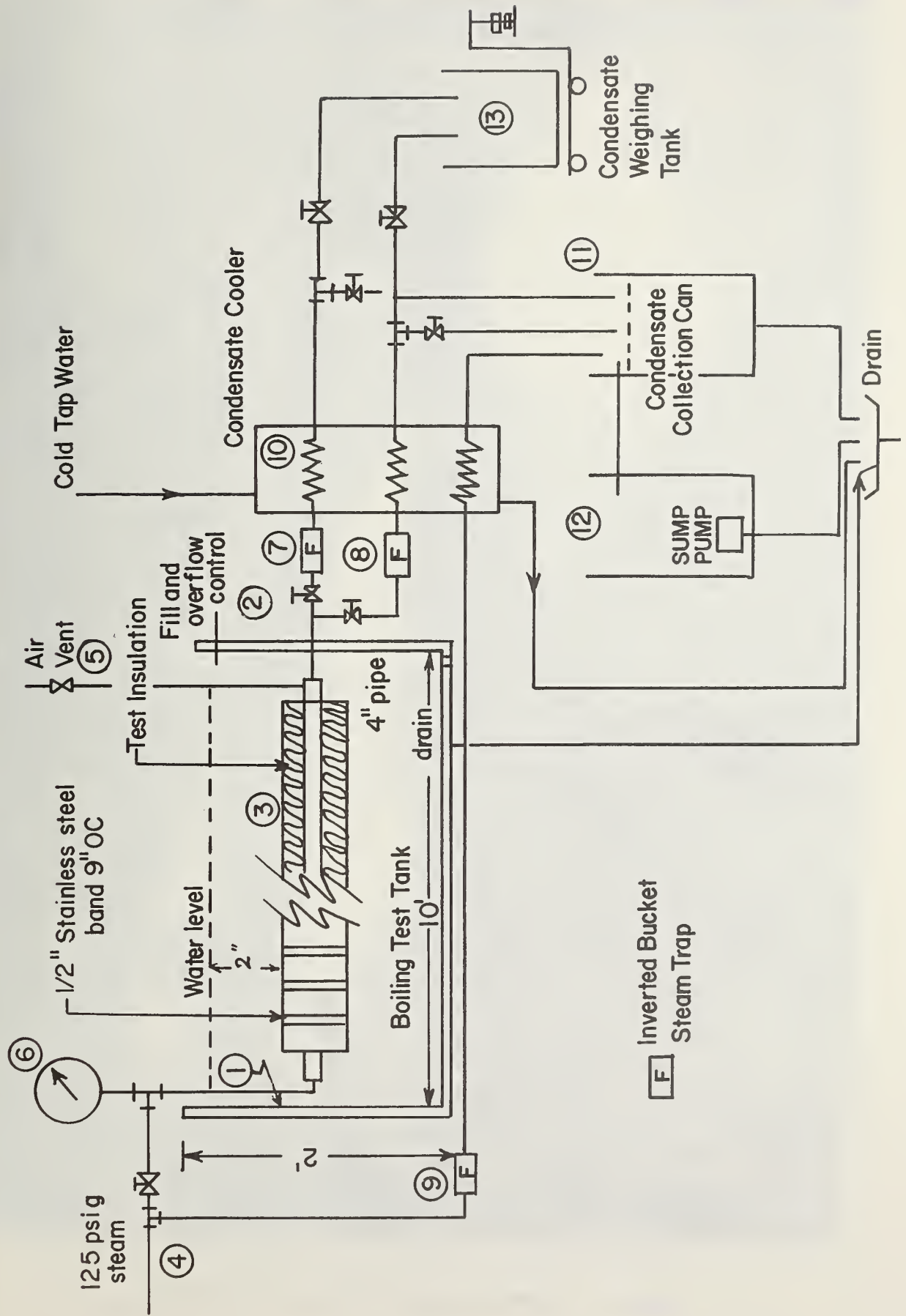

Figure 1. A schematic of the open tank boiling test apparatus

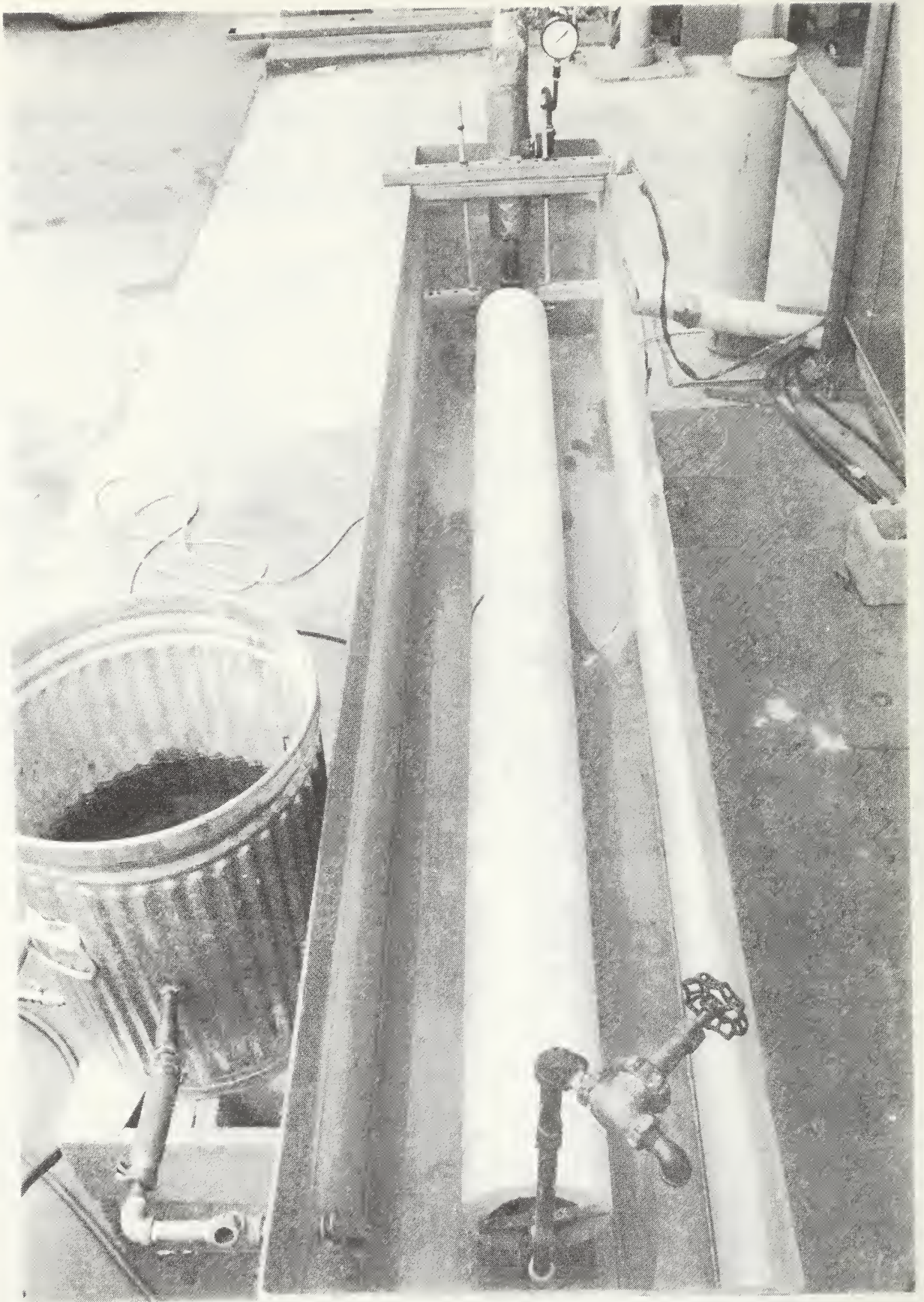

Figure 2. KAYLO #1 system before the boiling.



Figure 3. Pipe side view of KAYLO #1 specimen before boiling .



Figure 4. Conduit side view of KAYLO #1 specimen before boiling

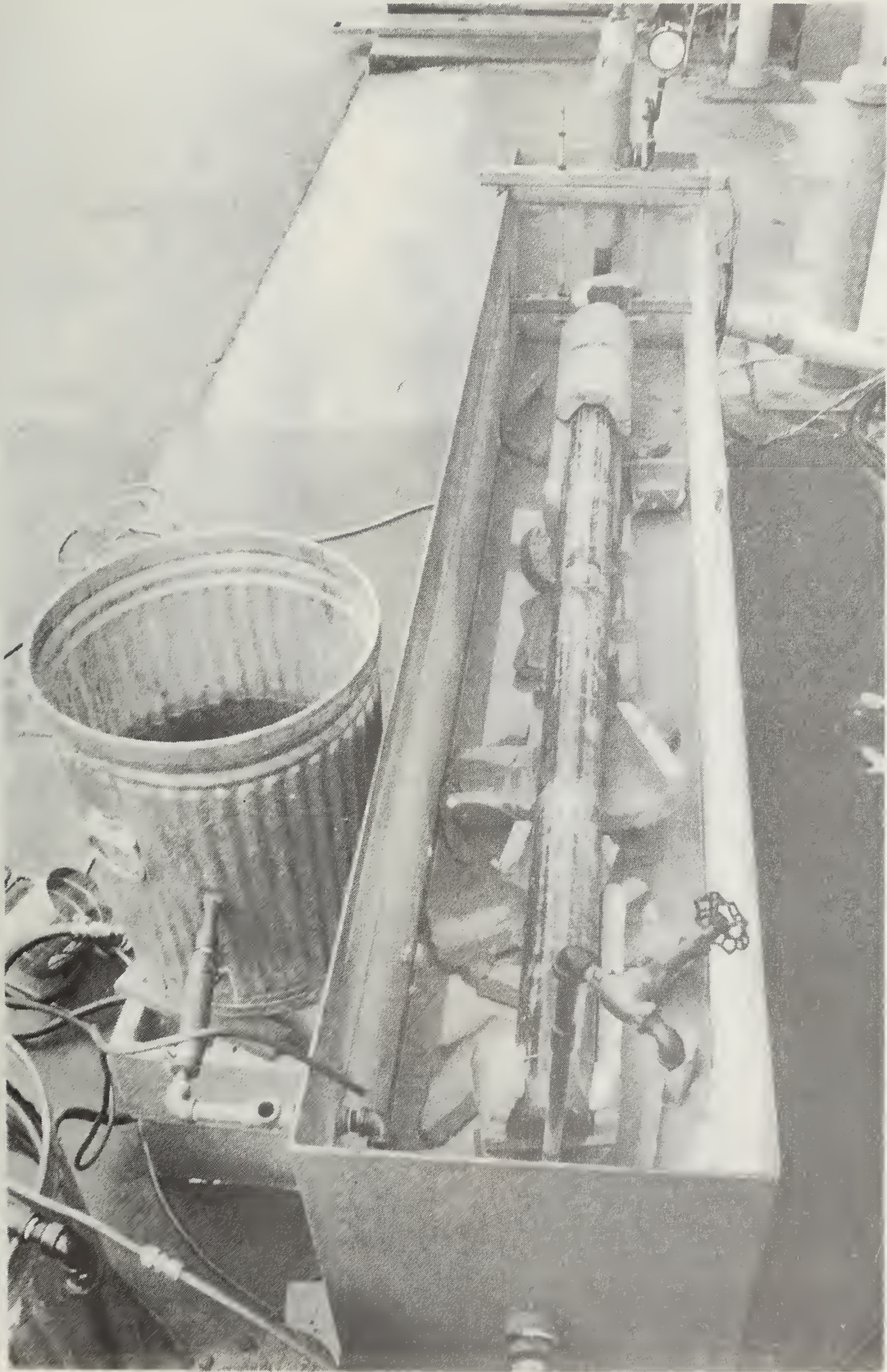

Figure 5. KAYLO #1 system after 5 hours boiling

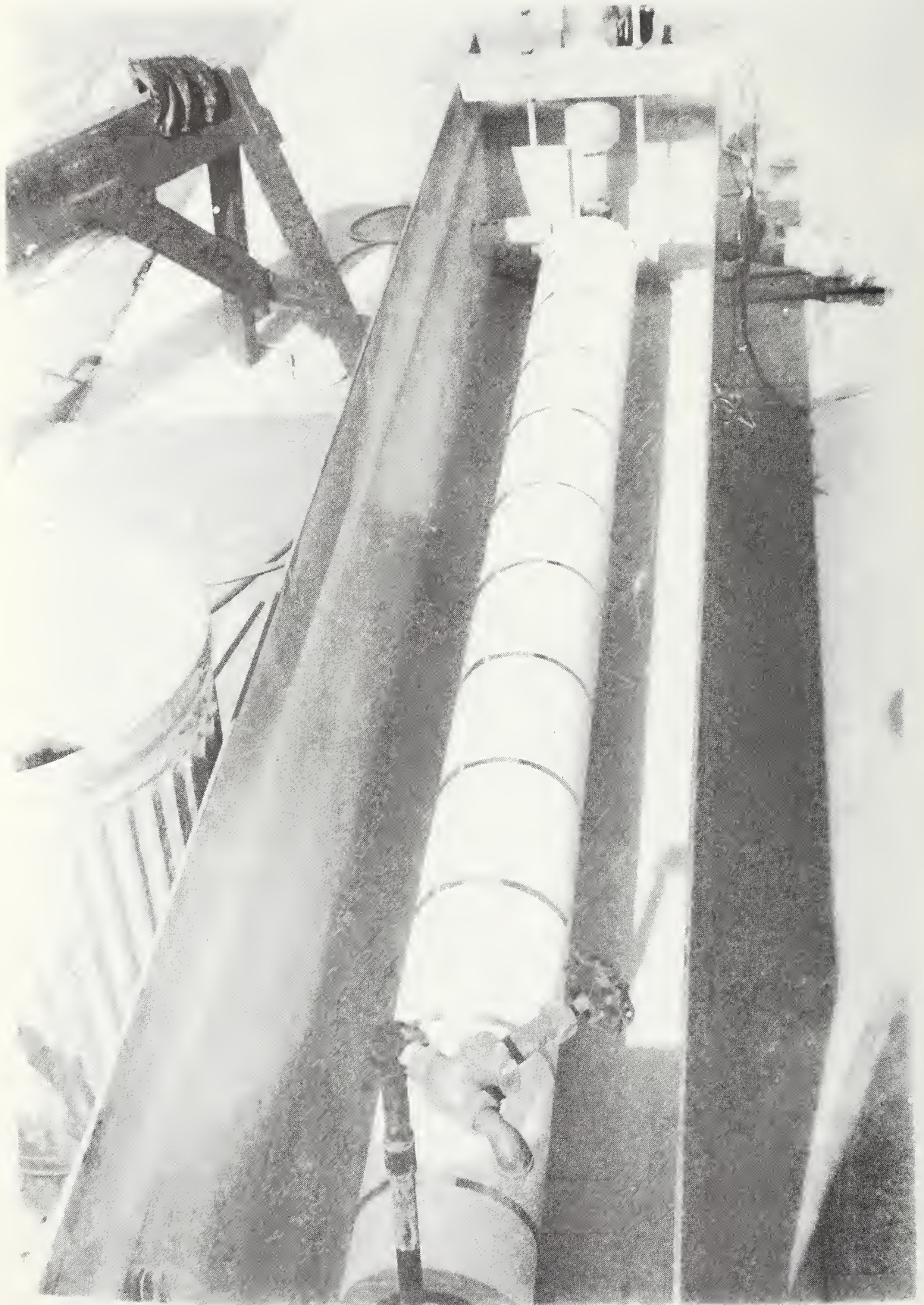

Figure 6. KAYLO #2 specimen before boiling

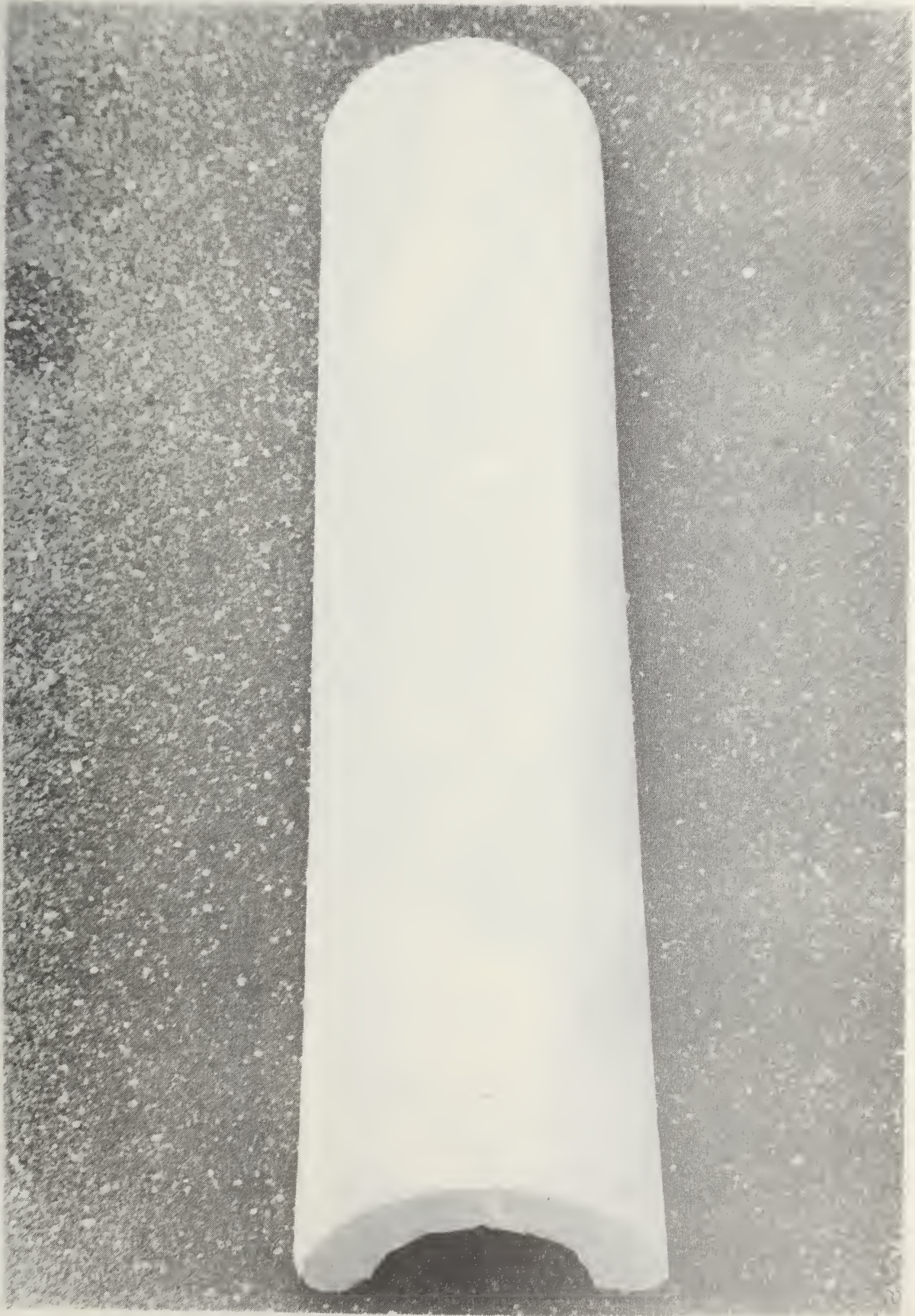

Figure 7. Conduit side view of KAYLO #2 specimen before boiling

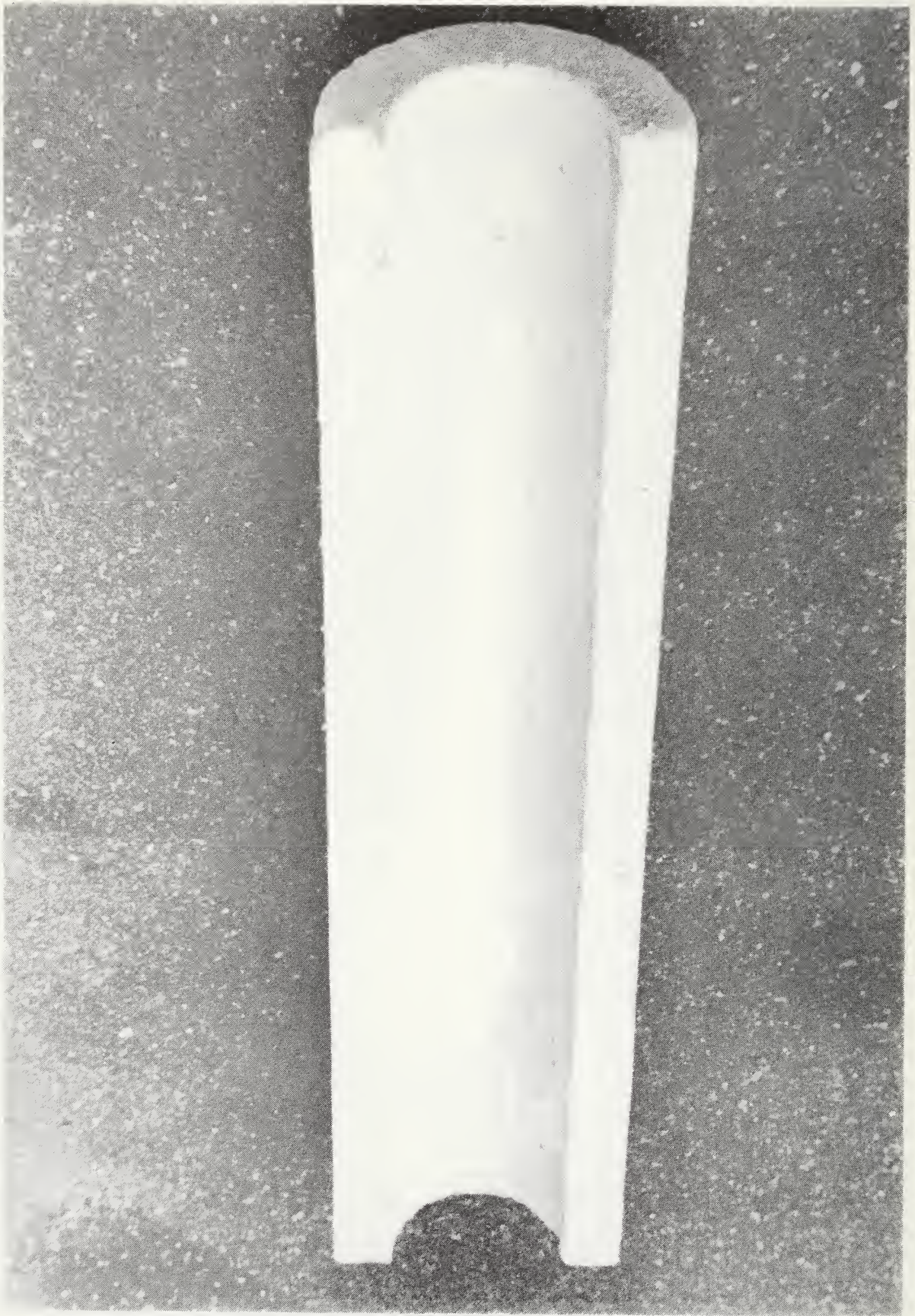

Figure 8. Pipe side view of KAYLO #2 specimen before boiling.



Figure 9. Kaylo #2 system after 72 hours boiling and 24 hours drying.

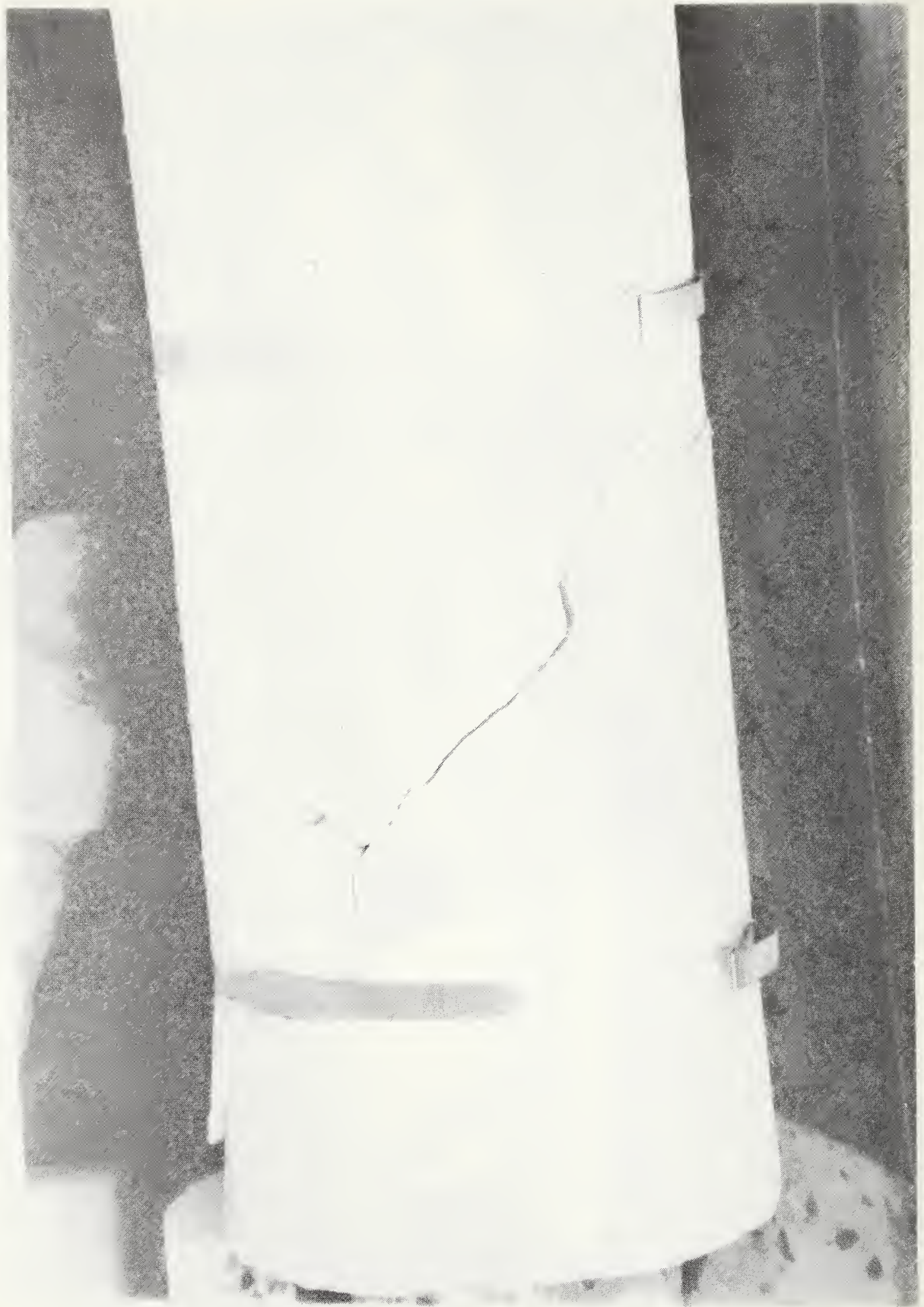

Figure 10. KAYLO #2 after 72 hours boiling and 24 hours drying

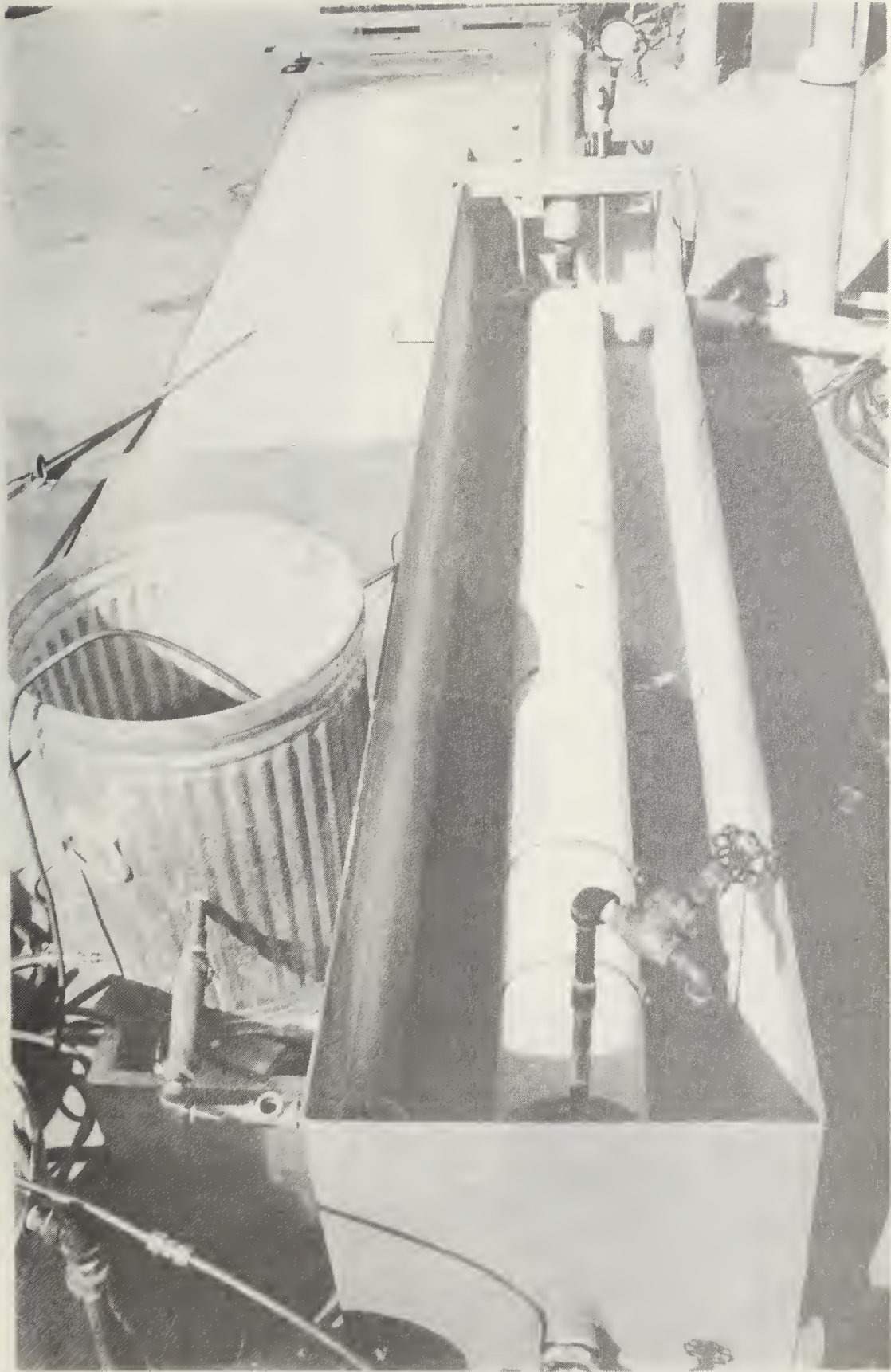

Figure 11. PABCO #1 system before boiling



Figure 12. A close-up of PABCO #1 system before boiling



Figure 13. Conduit side view of PABCO #1 specimen

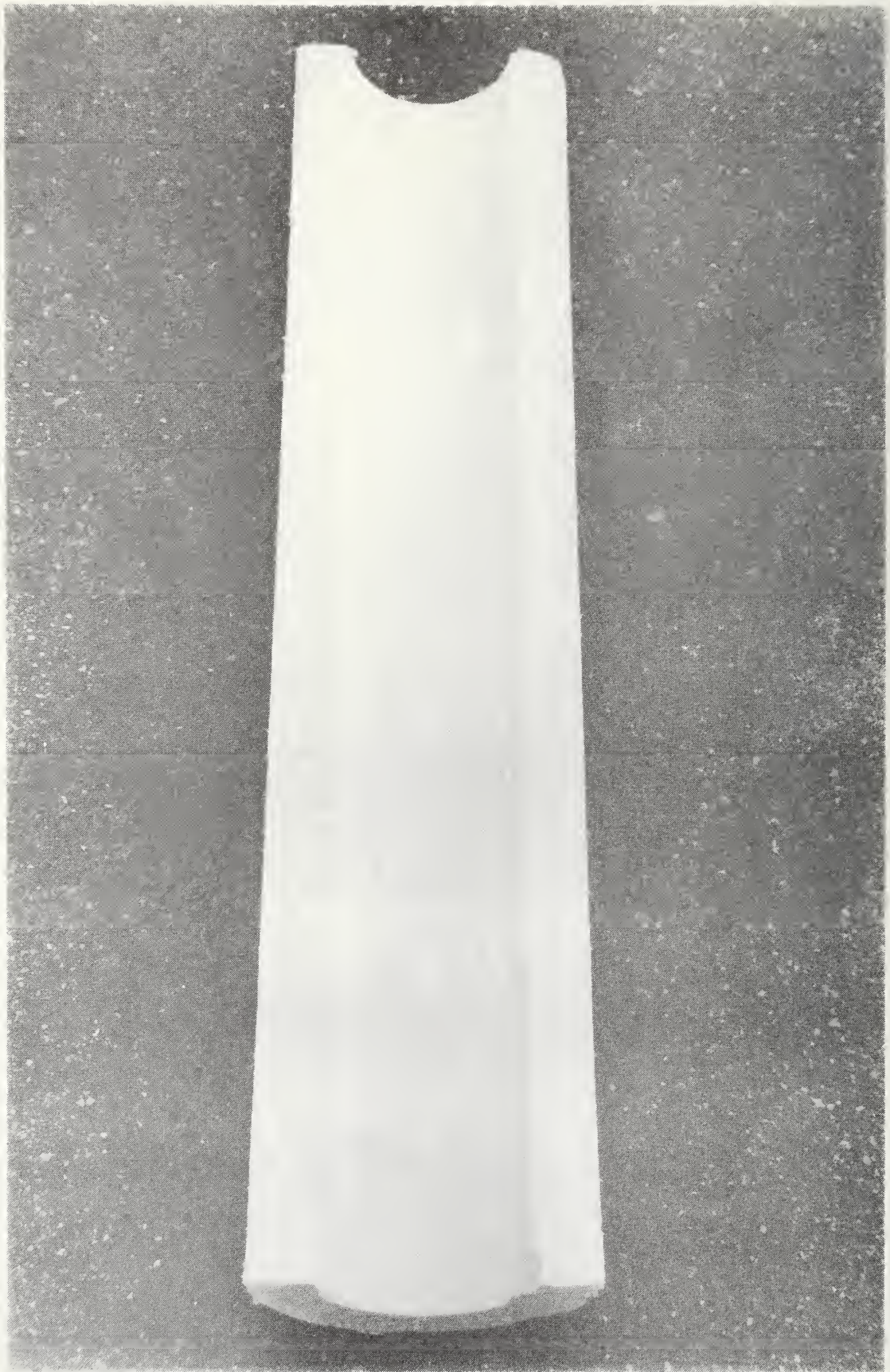

Figure 14. Pipe side view of PABCO #1 specimen



Figure 15. PABCO #1 system after 1 hour boiling

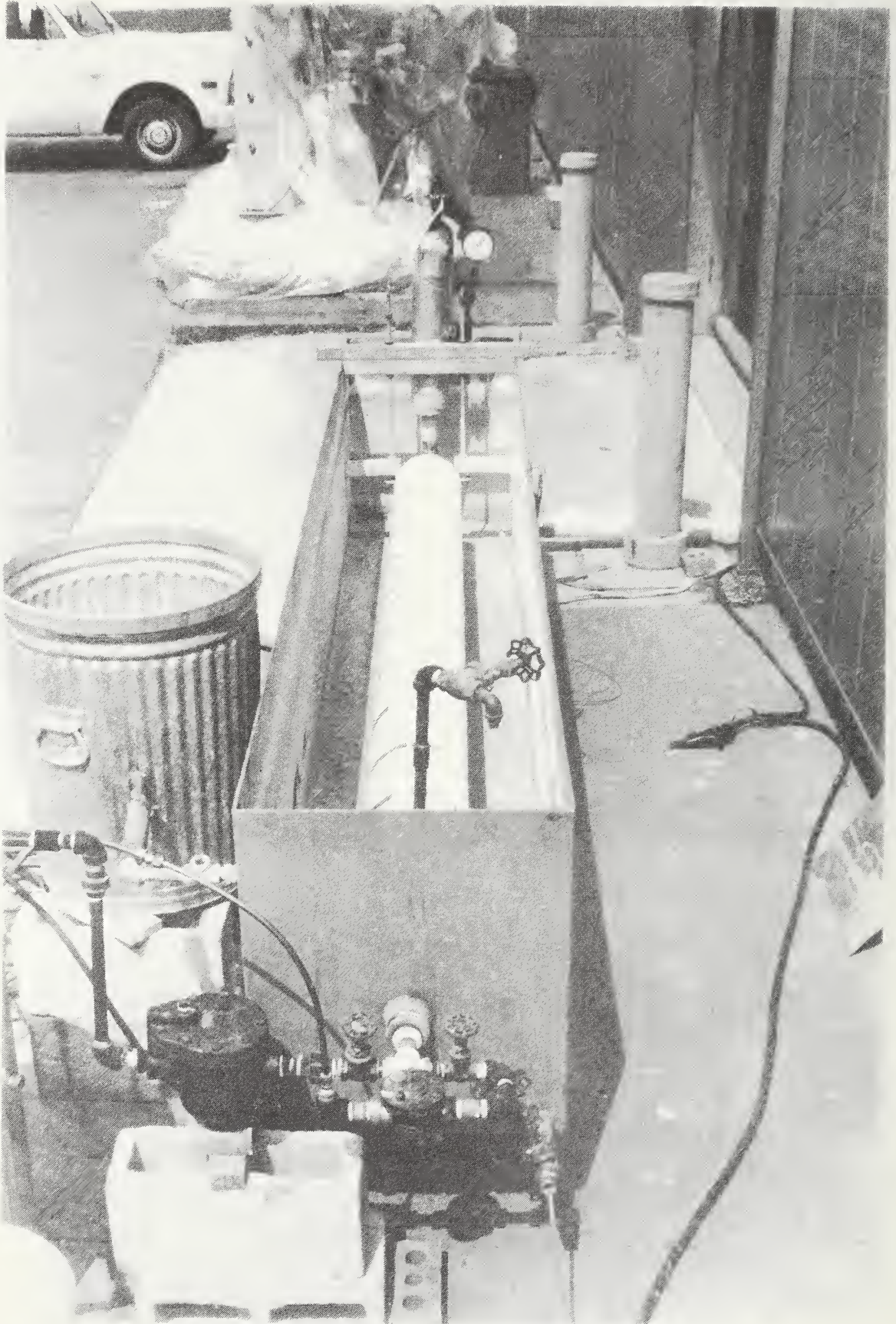

Figure 16. PABCO #2 system before the boiling



Figure 1/. Conduit side view of PABCO #2 specimen

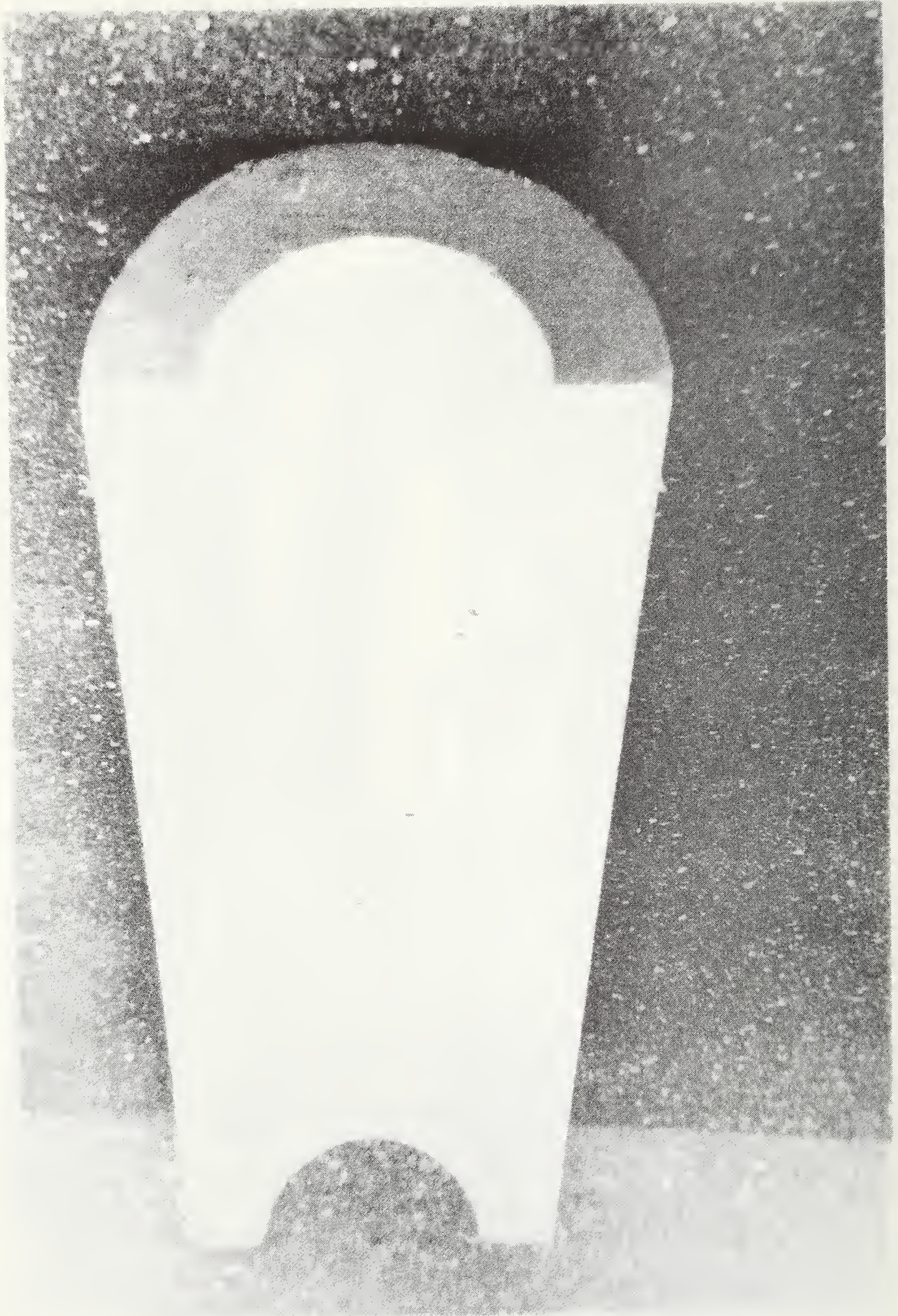

Figure 18. Pipe side view of PABCO #2 specimen



Figure 19. PABCO #2 system after 3 hours boiling

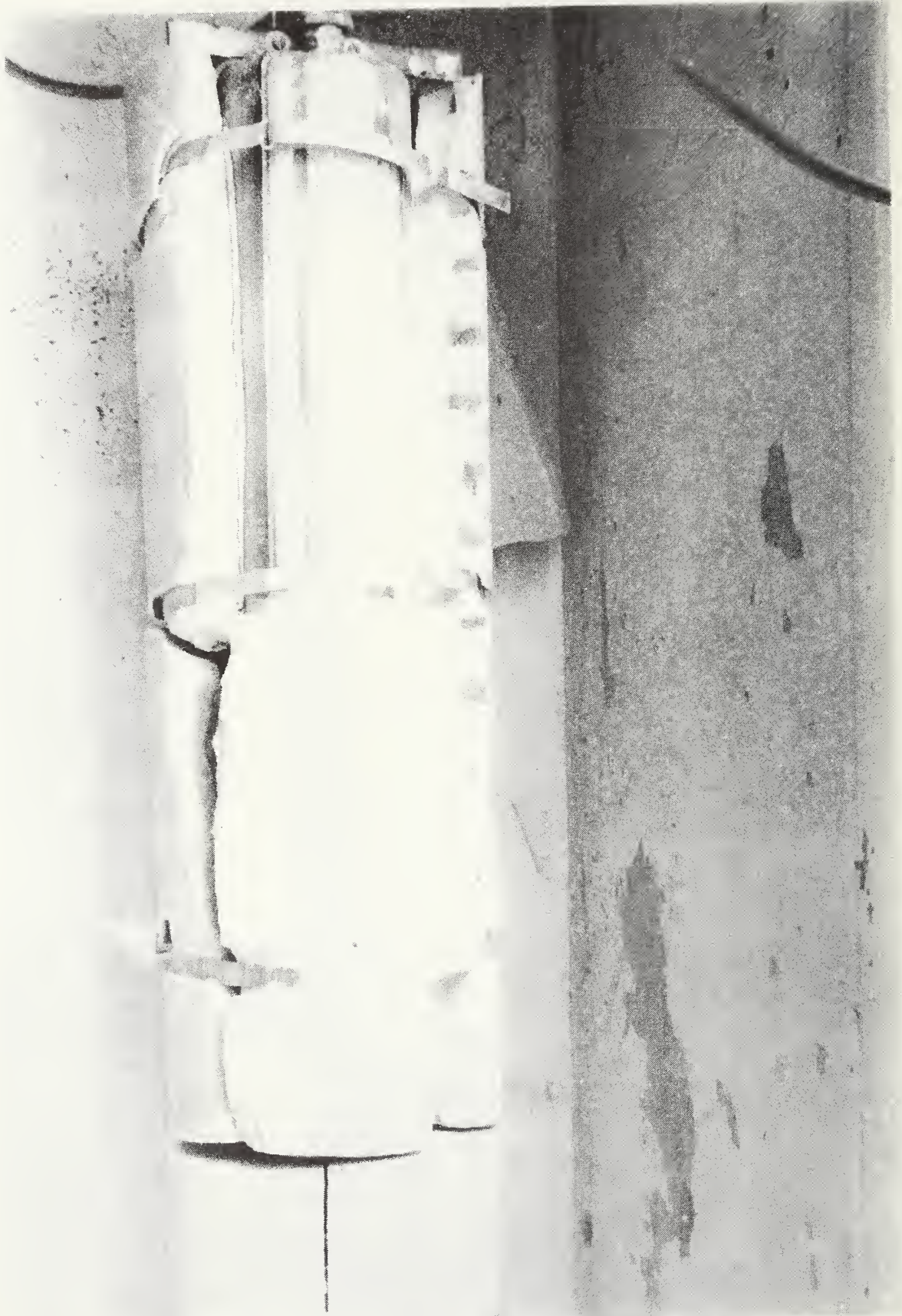

Figure 20. A close-up of PABCO #2 system after 3 hours boiling

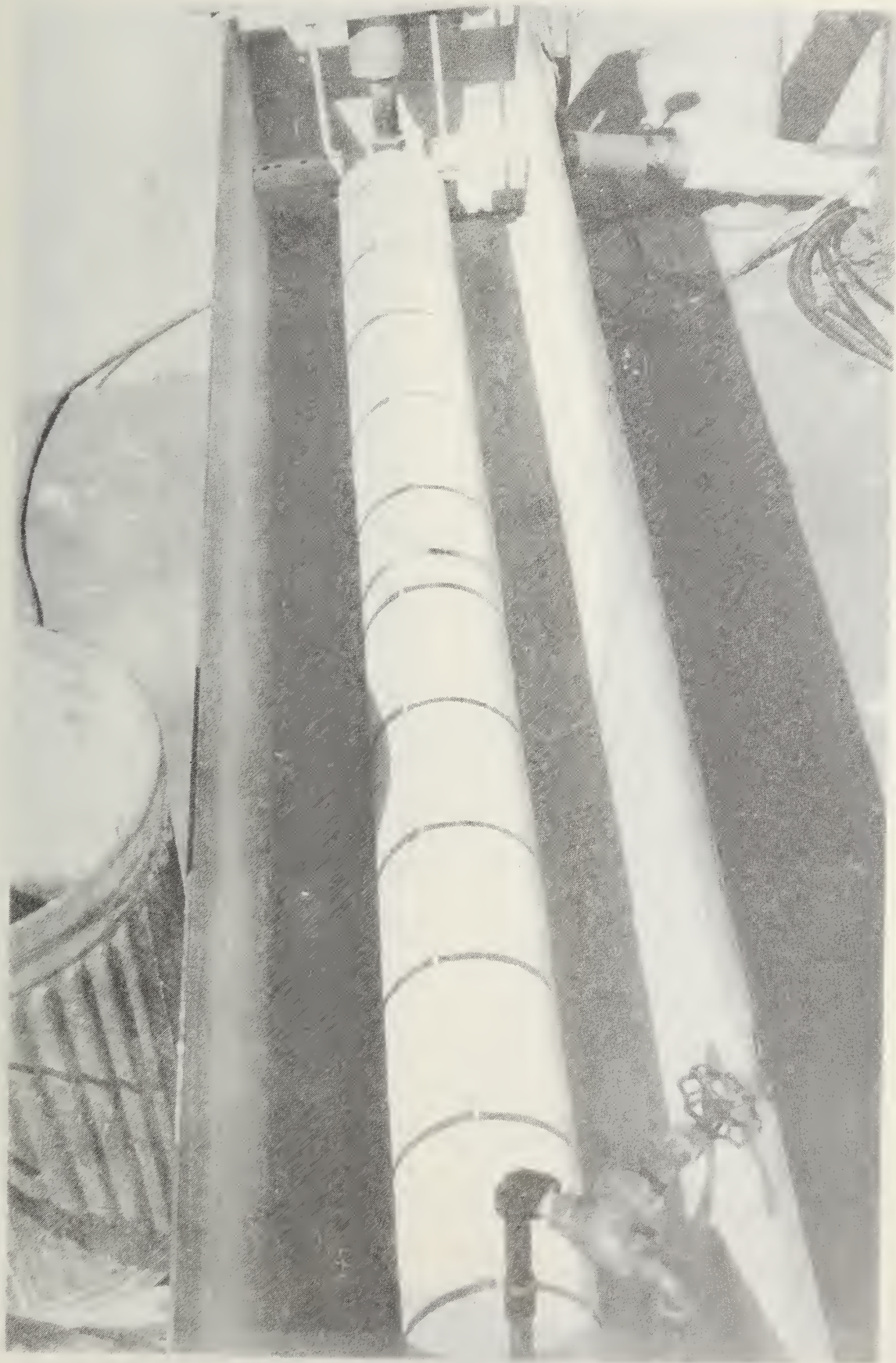

Figure 21. J/M system before the boiling

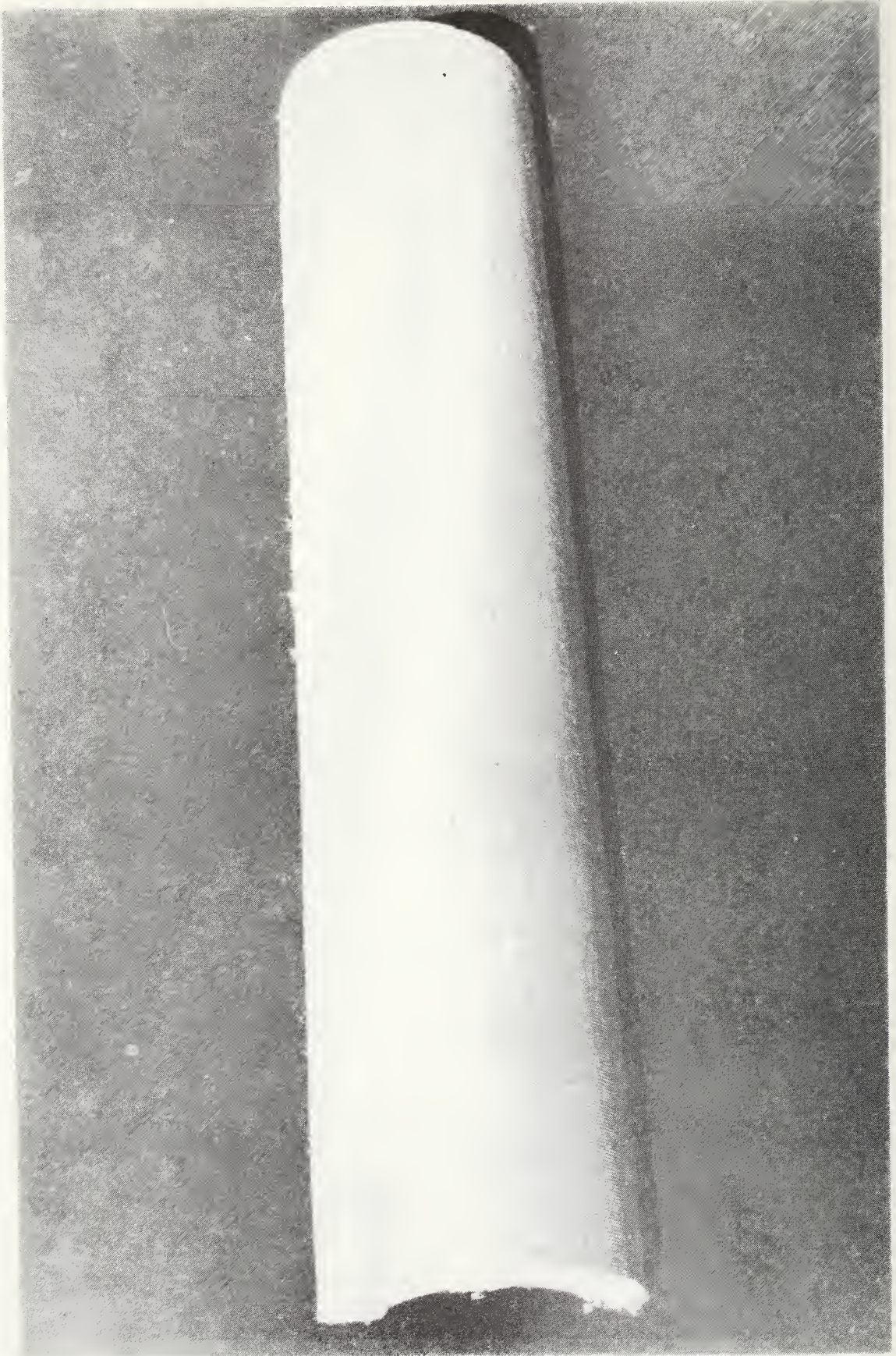

Figure 22. Conduit side view of J/M specimen before boiling



Figure 23. Pipe side of J/M specimen before boiling

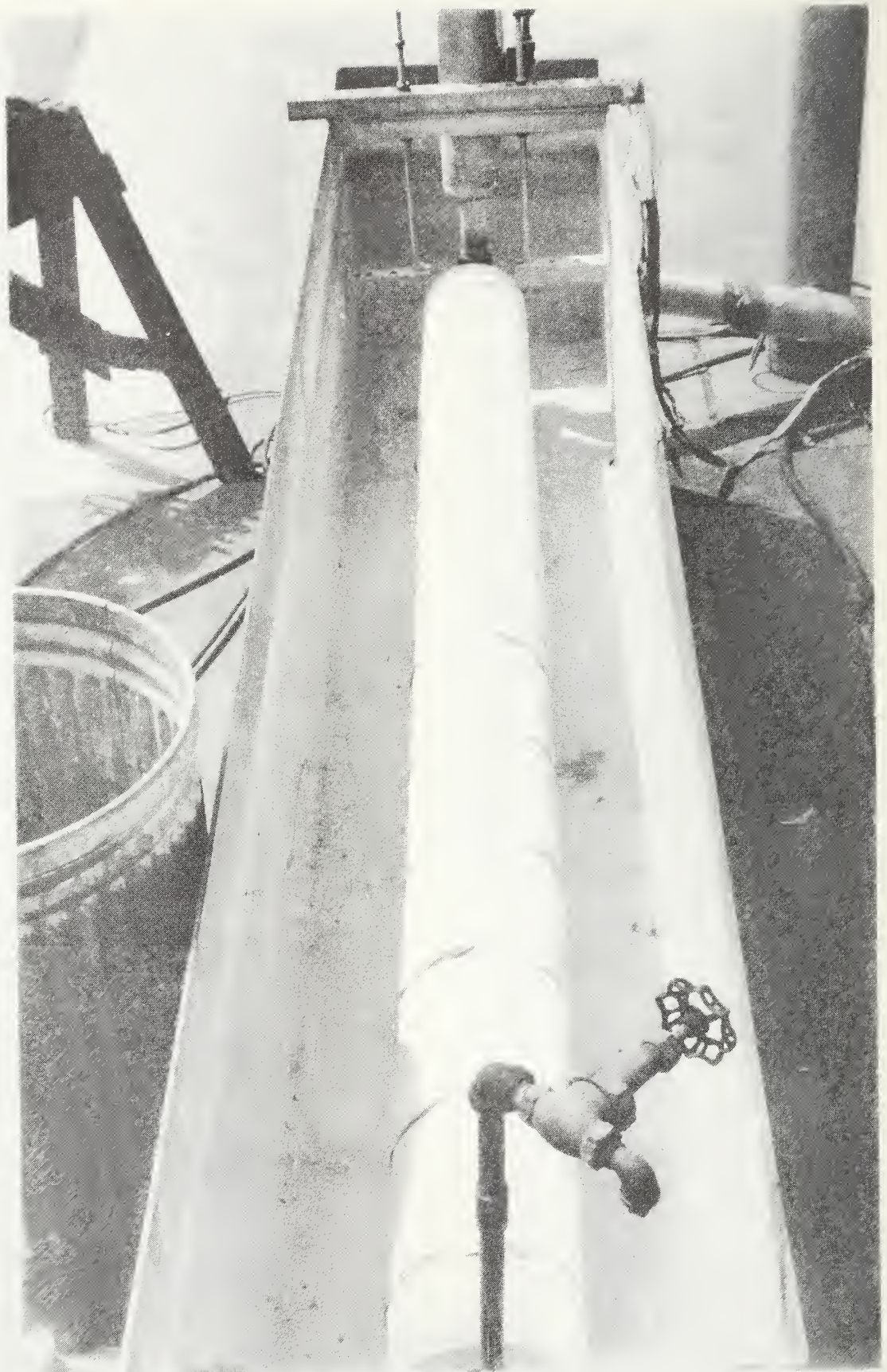

Figure 24. J/M system after 72 hours boiling and 24 hours drying

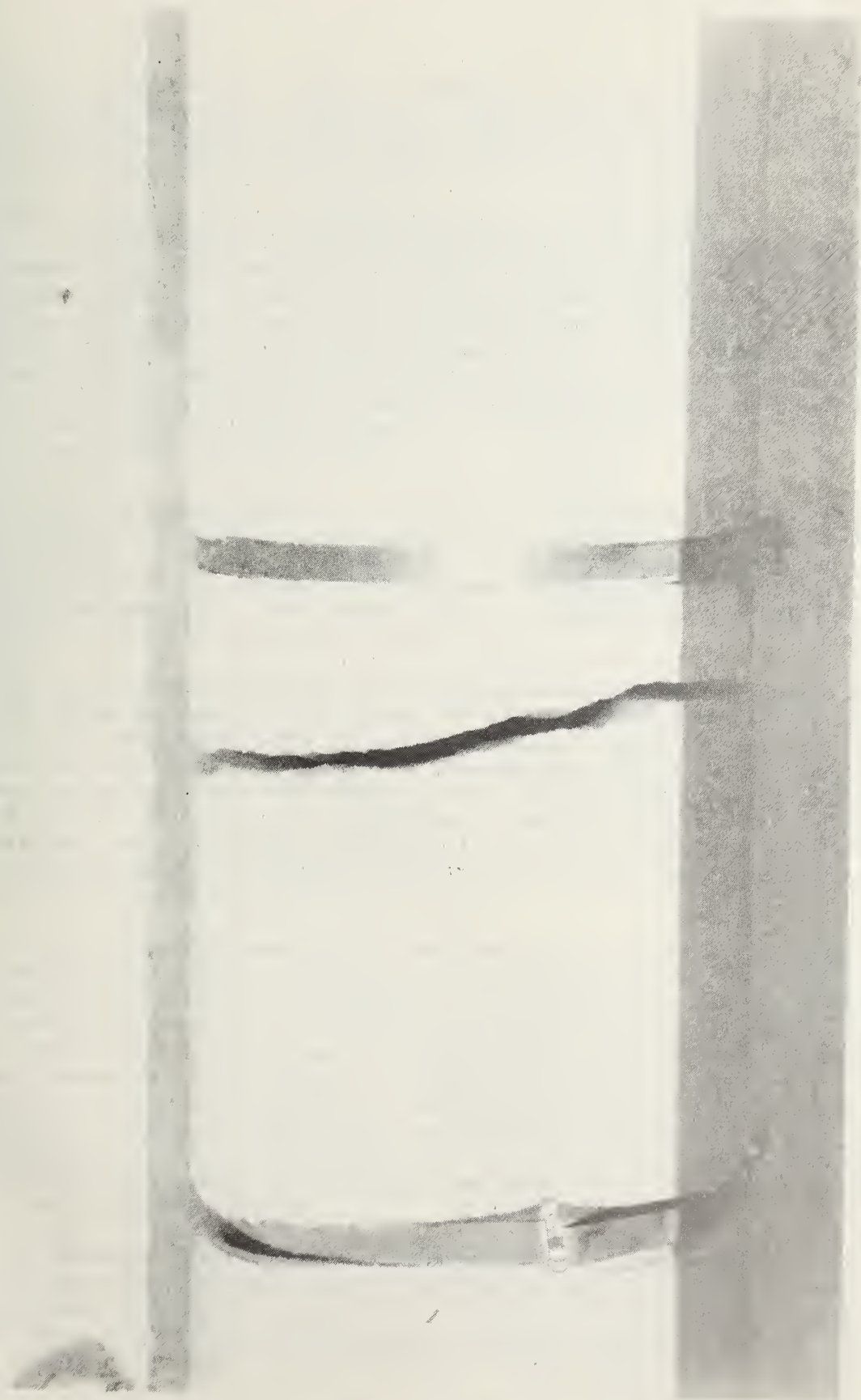

Figure 25. Close-up of J/M system after 72 hours boiling and 24 hours drying.

before and after the boiling. Special consideration was given to the fabrication of the test apparatus in such a manner that the temperature around the conduit is uniform and that the carrier pipe with the insulation can readily be removed from the conduit for inspection after the boiling test.

The apparatus used for the boiling test is illustrated diagrammatically in figure 26. It consisted of a reinforced plywood box for supporting and enclosing the conduit specimen, immersion electric resistance heaters for determining the heat transfer rate, a steam supply system and the necessary piping, pressure and level gages, and controls for temperature and water level in the pipe. The plywood box measuring 4 ft wide x 4 ft high x 19 ft long (shown in figure 27) was used to maintain a stable temperature around the pipe similar to that encountered in the underground environment. Nine baffle plates, as shown in figure 28, were installed in the plywood box to obtain uniform airflow and temperature around the conduit system.

The conduit specimen was supported in a level position along the longitudinal axis of the box and protruded through holes cut in each end of the box to fit the heater plates. The conduit extended about 3 inches beyond either end of the box. The conduit was wrapped with a blanket of glass fiber insulation 1/2-in thick and fastened at the lapped joints to simulate the thermal resistance of approximately 2 ft of earth cover.

The ends of the conduit were closed with flanged metal plates and secured with bolts. The joints between the end plates and the exterior of the 4-in steam pipe were fitted with gland seals to prevent leakage. Holes for 1-in pipe were provided at the top and bottom of each of the end plates, and one of the end plates was provided with two additional holes for 1/2-in pipe, for attachment of a sight glass. The 1-in pipe connections at the top and bottom of the end plates were used for filling and draining, for venting of steam, and for attachment of a pressure gage, as required. The details of the end plates and the openings in them are illustrated in figure 29.

The 4-in steam pipe was operated as a closed boiler with immersion electric heating elements during the periods when the heat transmission rate of the specimen was being measured. Conventional pipe flanges were attached to the threaded ends of the 4-in pipe. Steel plates 3/4-in thick were bolted to the flanges at each end. Each of these plates was drilled and tapped to receive a two-element immersion electric heater located along the center line of the pipe. In addition, holes for 1/4-in pipe were drilled and tapped at the top and bottom of each of the steel plates such that they were approximately tangent to the interior surface of the 4-in pipe. A third hole was provided near the top of the pipe in either end to establish the water level when the pipe was being used as an electric boiler.

Each of the immersion electric heaters consisted of two hairpin elements of 6 ft length each with a maximum capacity of 3,000 watts (6000 W per heater). The four elements were wired to provide individual control and each element was connected to a separate watt-hour meter through a disconnect switch, as shown in figures 30 and 31.

NBS INSULATION BOILING TEST (CONDUIT BOILING)

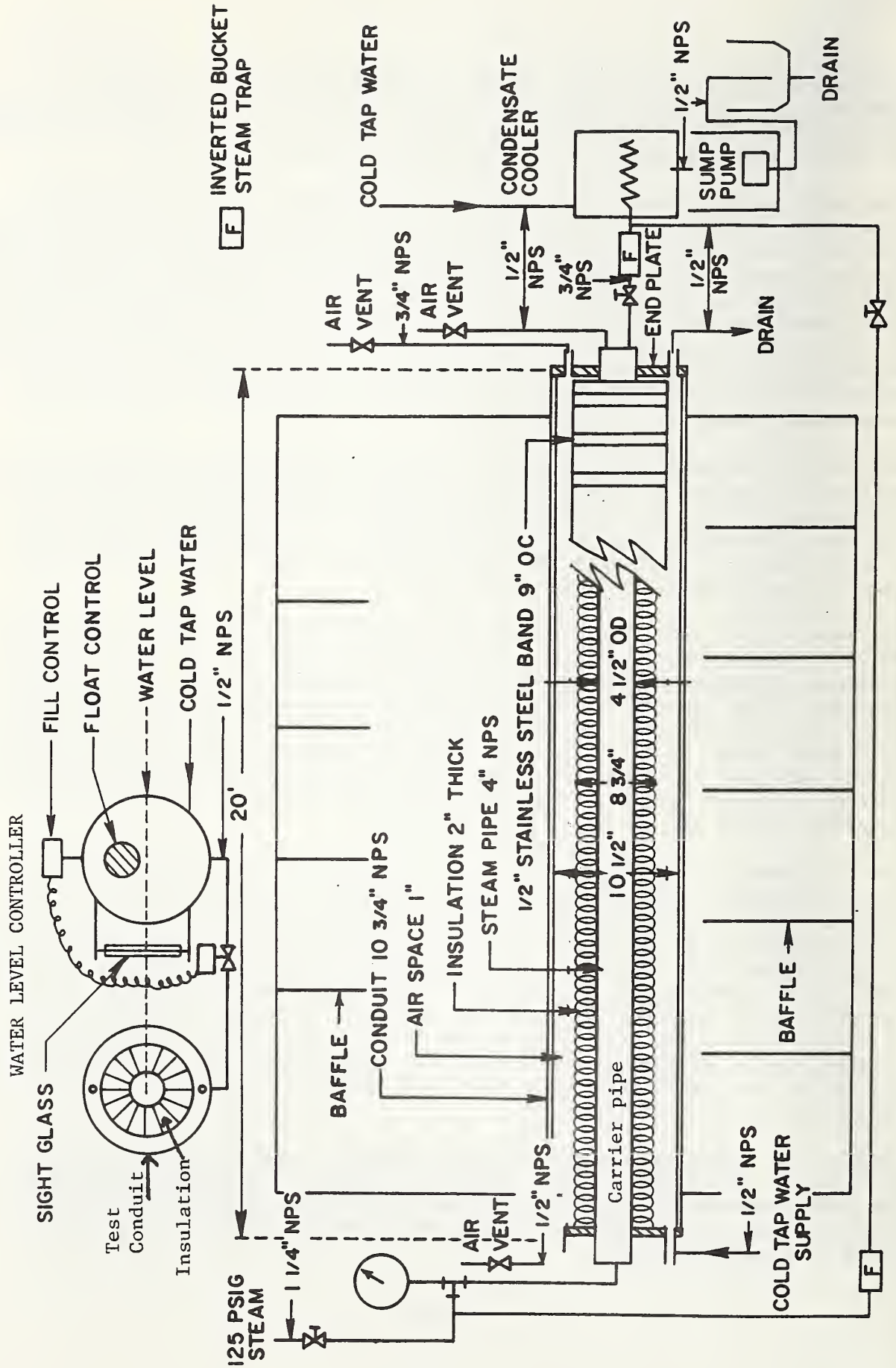

Figure 26. A schematic diagram of conduit boiling test for underground heat distribution system.

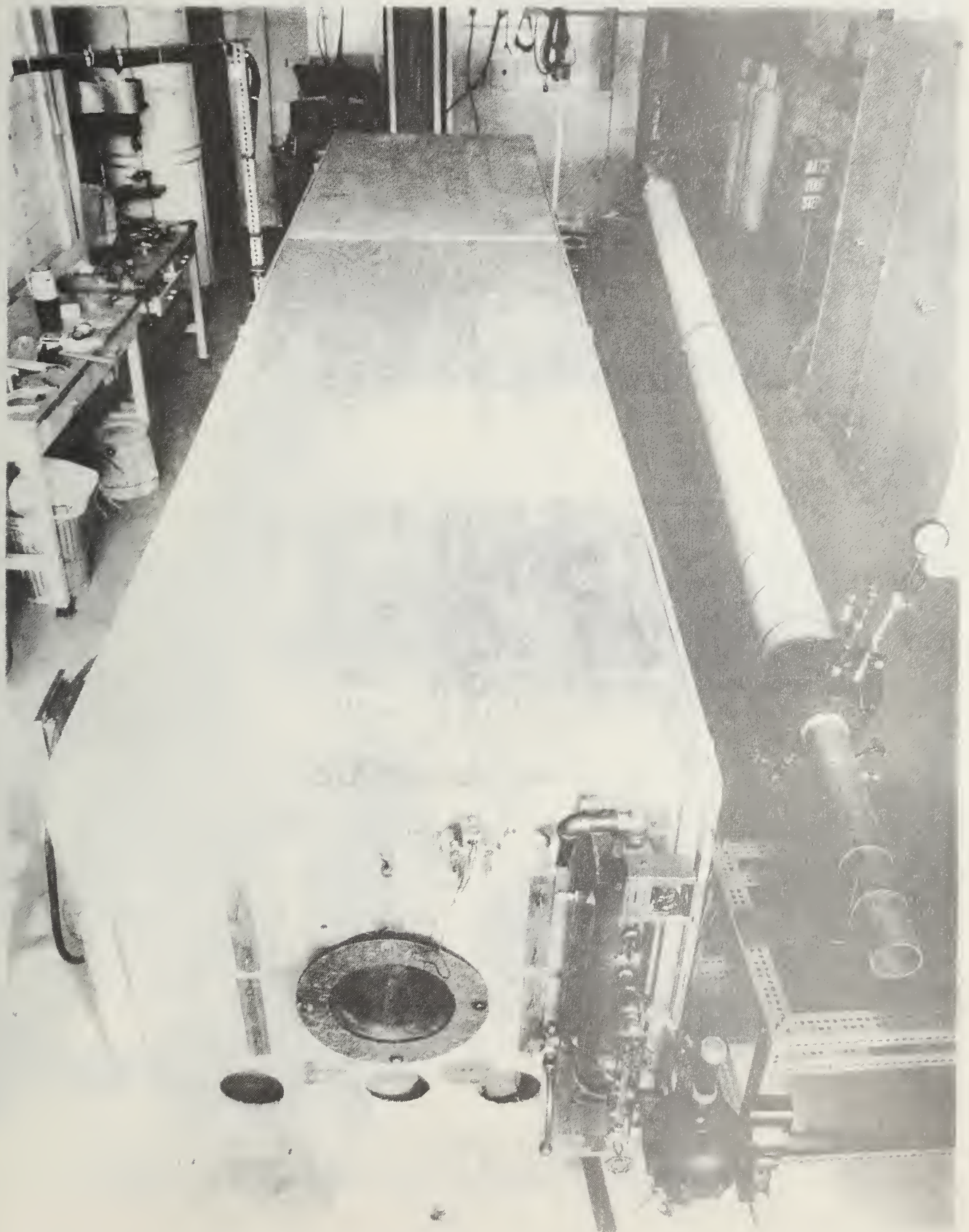

Figure 27. The thermal conditioning box for the conduit boiling test apparatus.

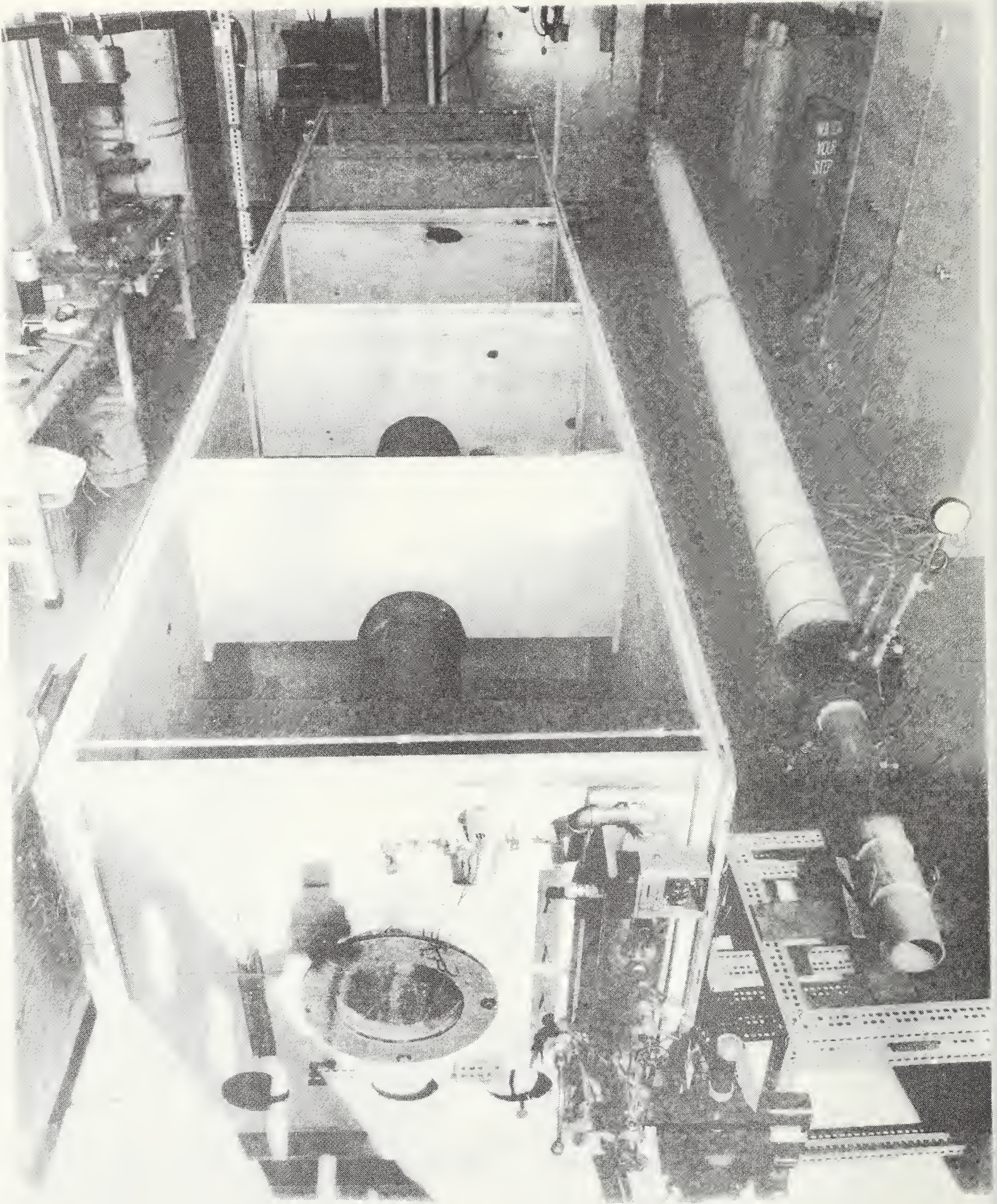
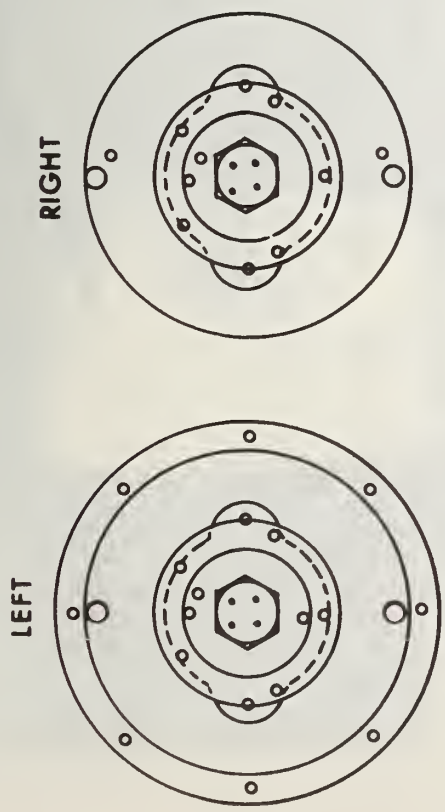
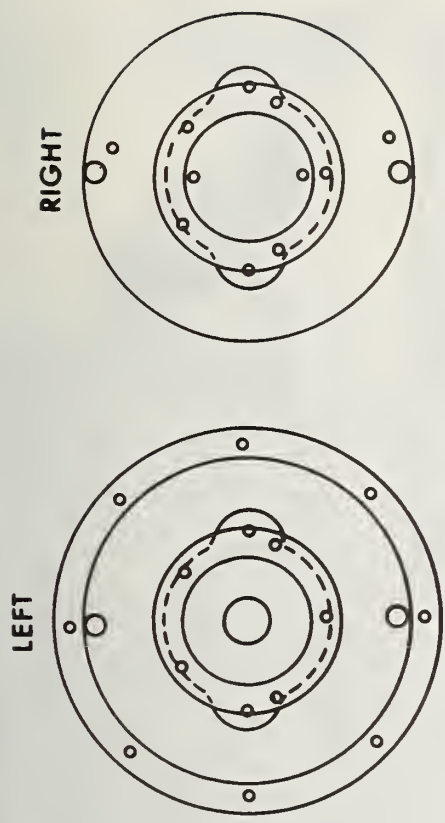

Figure 28. Baffle plates along the air passage to obtain uniform temperature around the test underground conduit system.

AN APPARATUS FOR STUDYING THE EFFECT OF BOILING ON PIPE INSULATION



END VIEW, ELECTRIC HEATING



END VIEW, STEAM HEATING

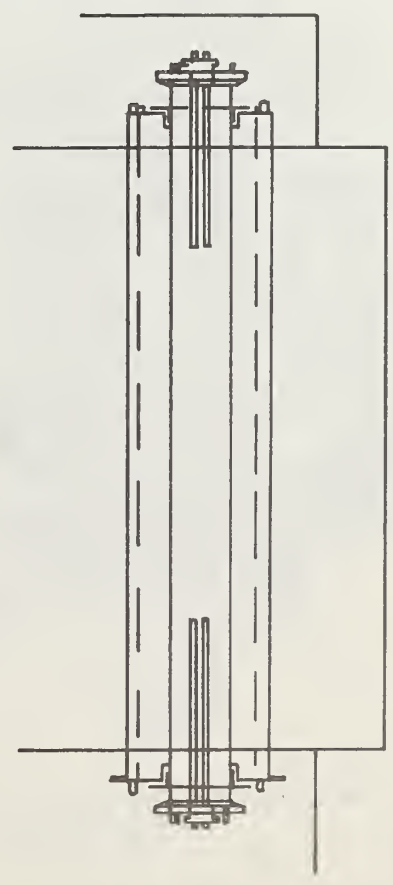

SIDE VIEW, ELECTRIC HEATING

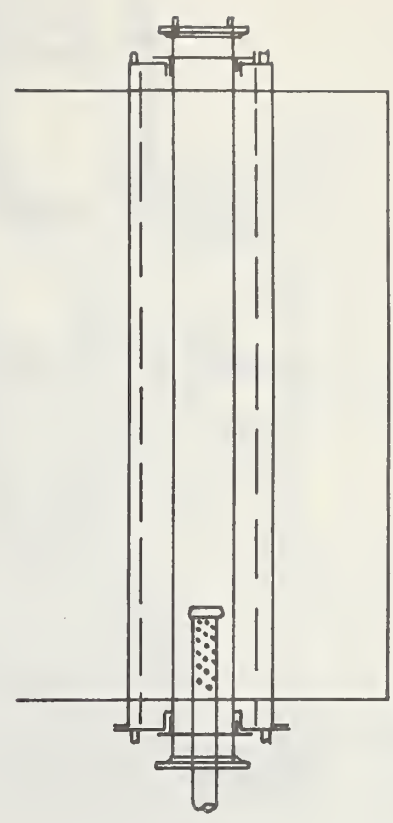

SIDE VIEW, STEAM HEATING

Figure 29. Header plates for the underground conduit insulation boiling tests: one for the electric heating (left) to measure pipe heat loss; the other for the steam heating (right) to provide boiling.

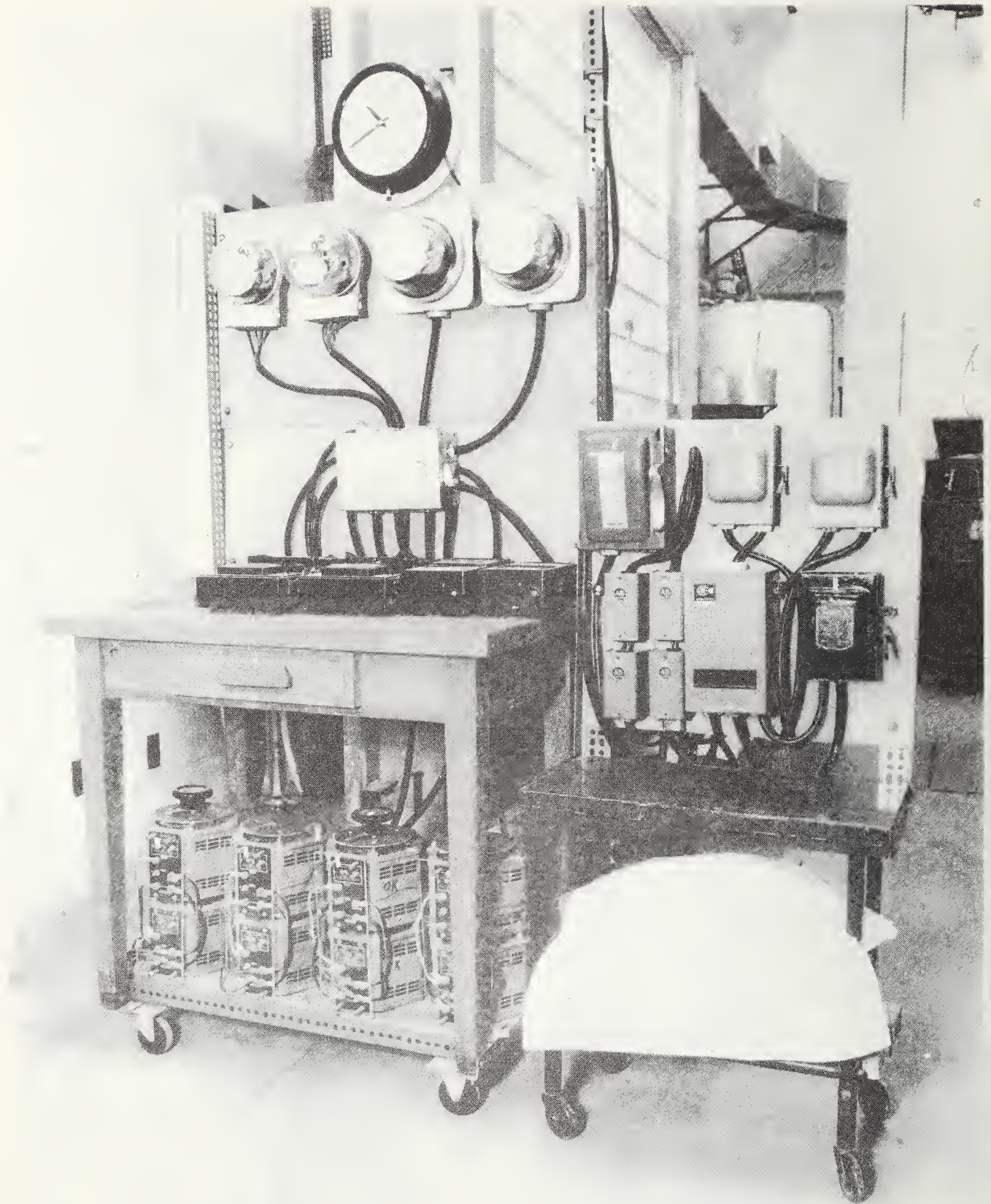

Figure 30. Instrumentation and power control panel for the insulation boiling test.

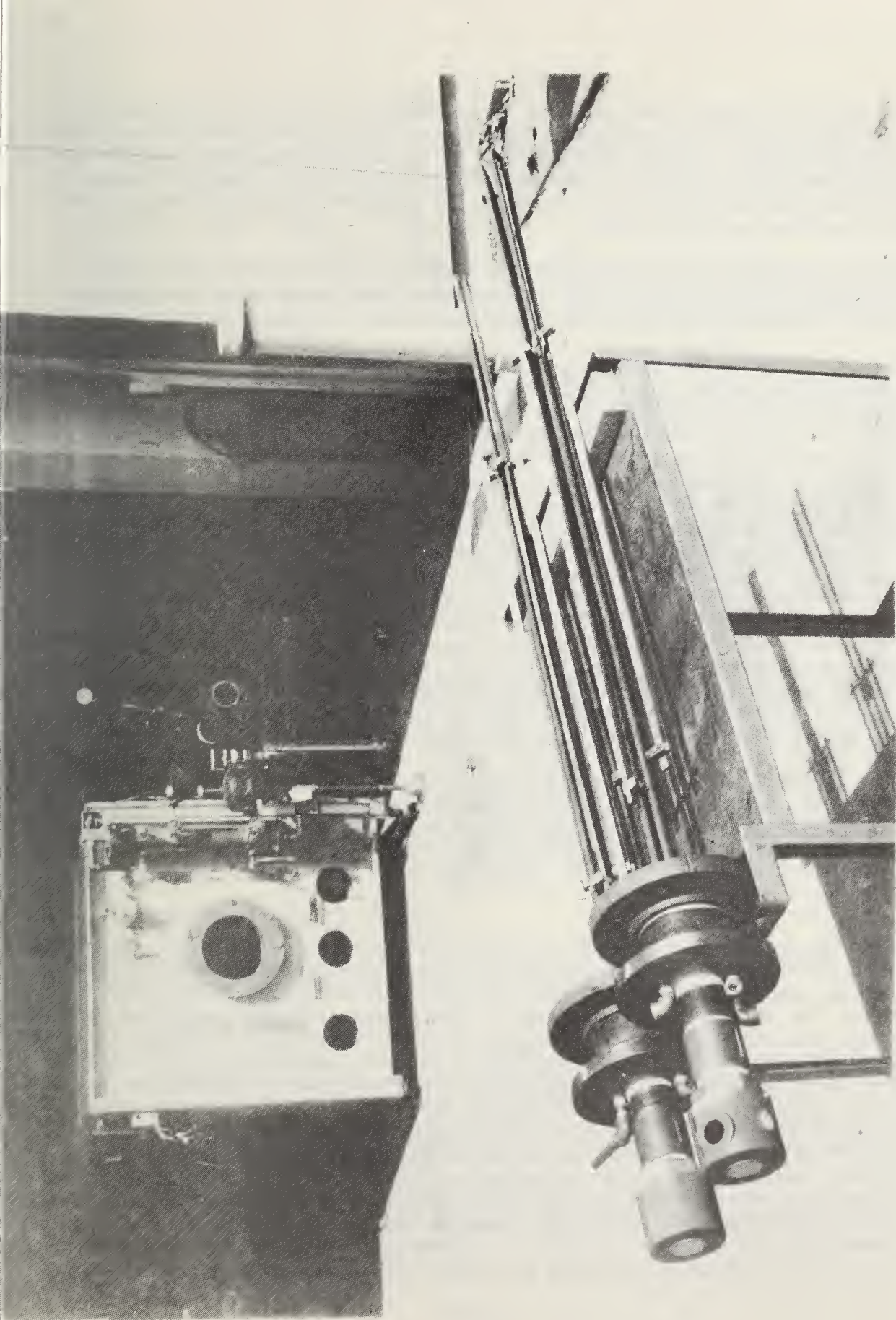

Figure 31. Immersion electric heaters for the heat loss test.

The electric heaters were actuated by a pressure controller connected to the 4-in pipe. The power supply was arranged so that either 230 volts or 115 volts could be applied to the heating elements. A second pressure controller served as a safety device and was used to disconnect all of the electric heaters by means of a magnetic switch if the pressure reached a preselected value above the operating pressure level.

Additional plywood boxes were built around the ends of the conduit that protruded through the main box. These boxes were filled with vermiculite insulation during the heat loss measurement test, to minimize the end heat loss.

A steam supply of 125 psig was connected to the 4-in test pipe during the boiling cycle, since the electric heaters were of inadequate capacity for this purpose. For the boiling period, the steel plates containing the electric immersion heaters were replaced by two other steel plates. One of these two plates was drilled at its center and fitted with a 1 1/4-in steam supply pipe. This supply pipe extended into the 4-in steam pipe about 18 in and projected about 6 in beyond the steel plate on the outside. The inner end of the 1 1/4-in pipe was capped, and several 1/4-in holes were drilled through the sides of this 18-in segment to make the total opening area to be the same as that of the cross section area of the 1 1/4-in pipe. The other end of the 1 1/4-in pipe was connected to the steam supply. The steel plate on this end of the 4-in pipe was provided with a hole for a 1/4-in pipe at the top, and a second hole for a 3/4-in pipe at the bottom. The upper connection was used as an air vent and as a connection for a pressure gage. The 3/4-in pipe connection was used to drain condensate. The condensate pipe was connected to a steam trap and to a water-cooled heat exchanger to cool the condensate to room temperature. The ends of the conduit were not insulated during the boiling cycle.

All insulation specimens were provided in the shape of 3-ft-long half cylinders of 2-in thickness, and were held around the 4-in carrier pipe by 1/2-in wide 32-gage stainless straps, wrapped around the insulation at 9-in on-center distances, as seen in figures 26 and 27.

2.3 TEST PROCEDURE

At the beginning of a test the 4-in pipe was operated as a closed steam boiler. The electric energy consumption of the immersion heaters was used to determine the heat transmission rate of the insulation before and after boiling. To prepare for this test, all openings in the conduit flanges except one vent were closed, and the 4-in pipe was completely filled with water, leaving one of the openings in the end flange at the top of the pipe open for the air venting. When the pipe had been filled with water, the vent was closed and the electric heaters were energized at a low rate of heat input. One of the openings, about a half inch from the top of the pipe, was opened slightly through a valve, and water was allowed to escape slowly as it expanded and as the steam pressure built up. When the steam began to escape from this opening, it was assumed that the water level had reached the level of the opening and the valve was closed completely. The steam pressure was then raised to 125 psig to attain a steam pipe temperature of 350°F. A thermocouple clamped to the 4-in pipe at one end was used as an indicator for setting the pressure control for the

electric heating elements. Thereafter, the pressure in the steam pipe was kept constant, and the energy input to the electric heaters was measured at regular intervals (twice during the working hours). The heat transmission test was terminated when the heat transfer rate, as measured by the electric energy used, became steady for 24 hours.

After the steady-state heat loss of the specimen was determined, the electric heaters were removed and the alternate steel end plates were bolted to the flanges on the 4-in steam pipe, thus permitting the boiler to provide steam for the system.

The steam trap and heat exchanger were connected to the outlet end of the 4-in pipe. The insulation space of the conduit was filled with water to saturate the insulation, after which enough water was drained out to lower the level to the half-full mark, as indicated by the sight glass.

Steam from the boiler was admitted to the 4-in pipe to raise the gage pressure to approximately 125 psig as rapidly as possible. The steam pressure was maintained essentially constant for a period of 192 (or 96) hours, during which the water in the insulation space boiled vigorously. The steam produced in the insulation space was allowed to escape from one of the vents in the end plate, and cold water was fed into the insulation space to maintain a constant water level.

At the end of 192 or 96 hours of boiling, the water was drained from the annular space between the conduit and carrier pipe, and compressed dry air was introduced into the conduit for 48 hours with 125 lbs of steam in the 4-in pipe to dry out the insulation. After the 48-hr drying period, the steam boiler and steam trap were disconnected from the 4-in pipe, and the alternate steel plates containing the electric resistance heaters were again attached to the pipe. As before, the 4-in pipe was operated again as a closed steam boiler at a pressure of 125 psig, to determine the post-boiling heat loss. The heat loss test was continued until a new value for steady-state heat transfer rate was obtained.

2.4 TRI-SERVICE EVALUATION CRITERIA

The Tri-Service criteria specify that any one or more of the following kinds of damage to the insulation constitute cause for rejection.

- (1) Portion fallen from the pipe.
- (2) Eccentricity of the insulation relative to its original position.
- (3) Significant opening of the longitudinal or circumferential joints.
- (4) Significant erosion of the insulation of the joints.
- (5) Cracks or rupture in the insulation revealing the pipe surface.
- (6) Physical or chemical changes in the insulation which are likely to impair its function.
- (7) Spalling or delamination of the insulation.
- (8) More than 10 percent increase of heat loss after the boiling and drying.

2.5 TEST RESULTS

2.5.1 Kaylo-10 System

The heat loss before the 192-hr boiling test was 611 watts, and after the boiling test it was 747 watts, based on at least 24 hours of steady conditions. Temperatures and heat transfer during the test are shown in figure 32. The surface temperature distribution profiles along the conduit during the heat loss tests before and after boiling tests are shown in figure 33.

The insulation removed from the conduit after boiling for 192 hours and drying is shown in figure 34. It can be seen at each end of sections that the insulation scaled and flaked away from the pipe. At some of the joints, between the insulation segments, the boiling action created large enough holes so that the bare pipe could be seen (figure 35).

Some of the insulating material that came off during the boiling collected in the bottom of the conduit, as shown in figure 36.

The insulation was weighed after boiling and there was a loss in weight of about 3 lbs (3.6 percent of the initial weight, 84.25 lb).

The longitudinal average conduit surface temperatures for pre- and post-boiling tests obtained from figure 33 are 144.1°F and 157.9°F, respectively. The large temperature at the ends and a mid-point temperature hump shown in figure 33 is due to the pipe support. Assuming the pipe temperature to be 350°F and pipe length at 20 ft, the overall pipe heat transfer factor of C in the unit of Btu/h.ft.F is:

$$C = \frac{(3.413) (611)}{(20) (350-144.1)} = 0.506 \text{ before the boiling}$$

and

$$C = \frac{(3.413) (747)}{(20) (350-157.9)} = 0.632 \text{ after the boiling.}$$

The pipe heat transfer factor for this particular underground system, therefore, increased more than 20 percent, which exceeded the Tri-Service criteria of ten percent. The system is considered to have failed the Tri-Service boiling test.*

2.5.2 Thermo-12 System

The heat loss before the 192-hr boiling test was 656 watts, and after the boiling test it was 674 watts, based on at least 24 hours of steady conditions. Temperatures and heat transfer during the test are shown in figure 37. The surface temperature distribution profiles along the conduit during the heat loss tests before and after boiling tests are shown in figure 38.

* The same test is repeated later for new insulation specimens, which met the Tri-Service criteria.

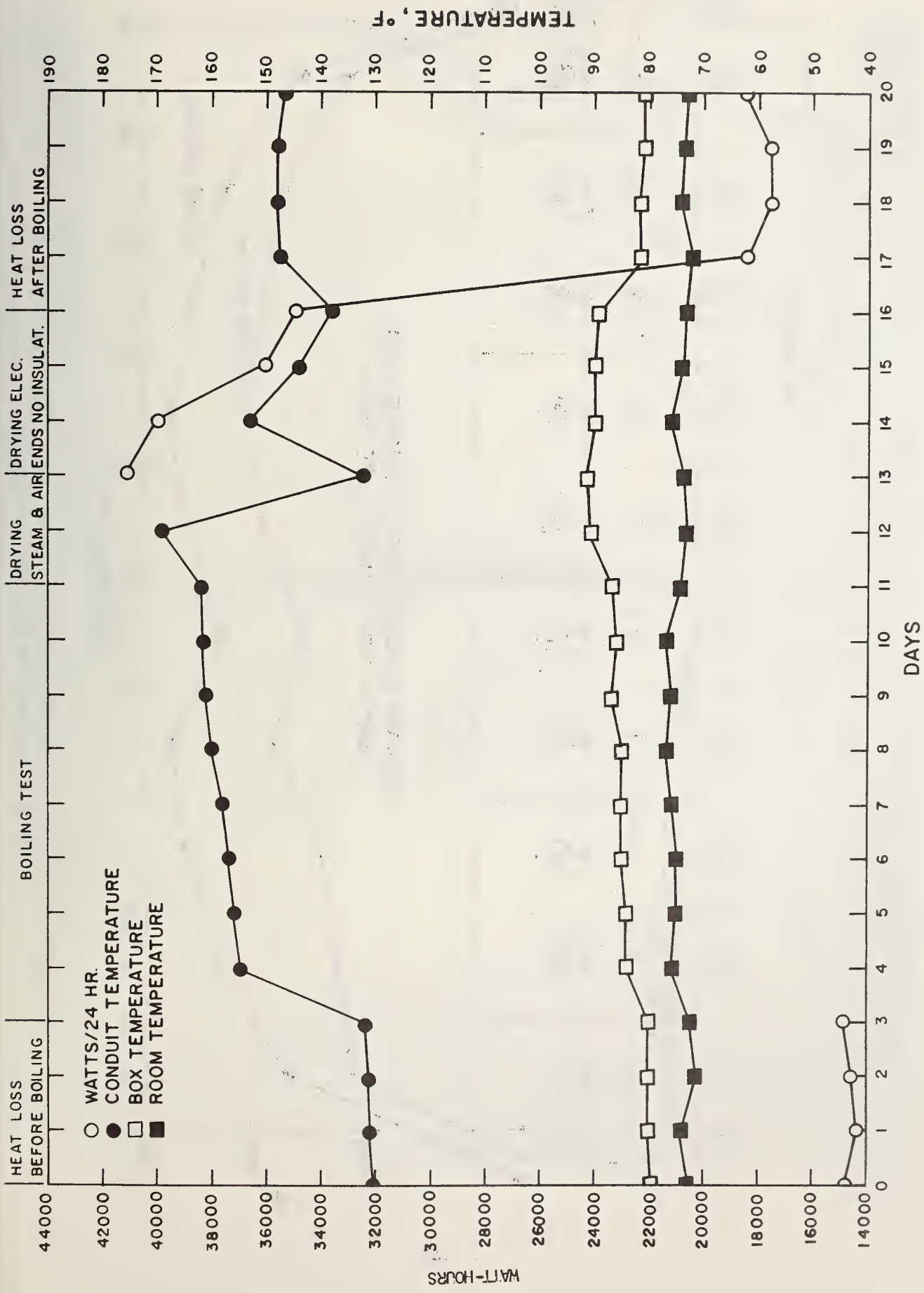

Figure 32. Heat loss and temperature data during the test for KAYLO-10 insulation.

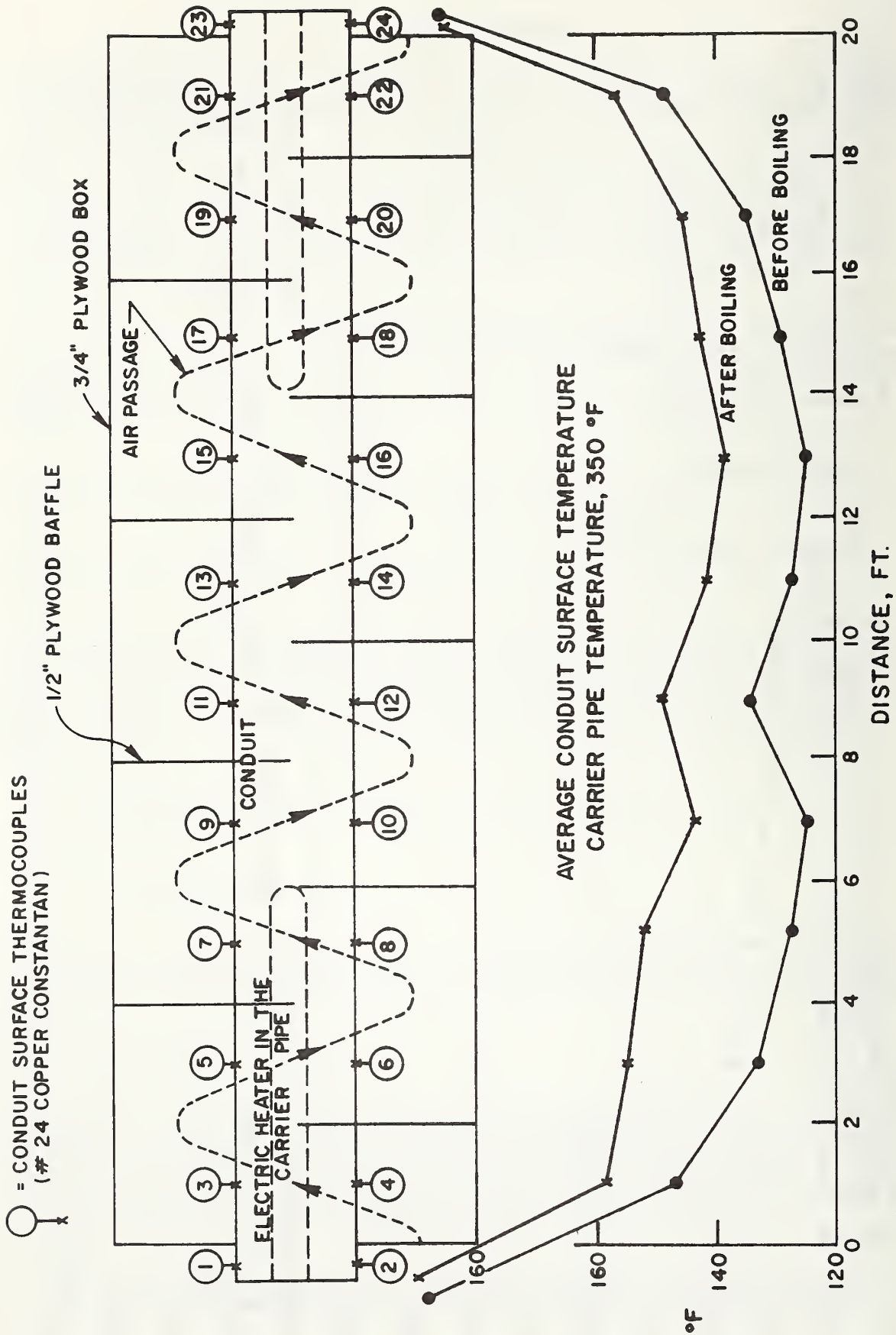

Figure 33. Longitudinal distribution of the conduit surface temperature before and after the KAYLO-10 boiling tests.

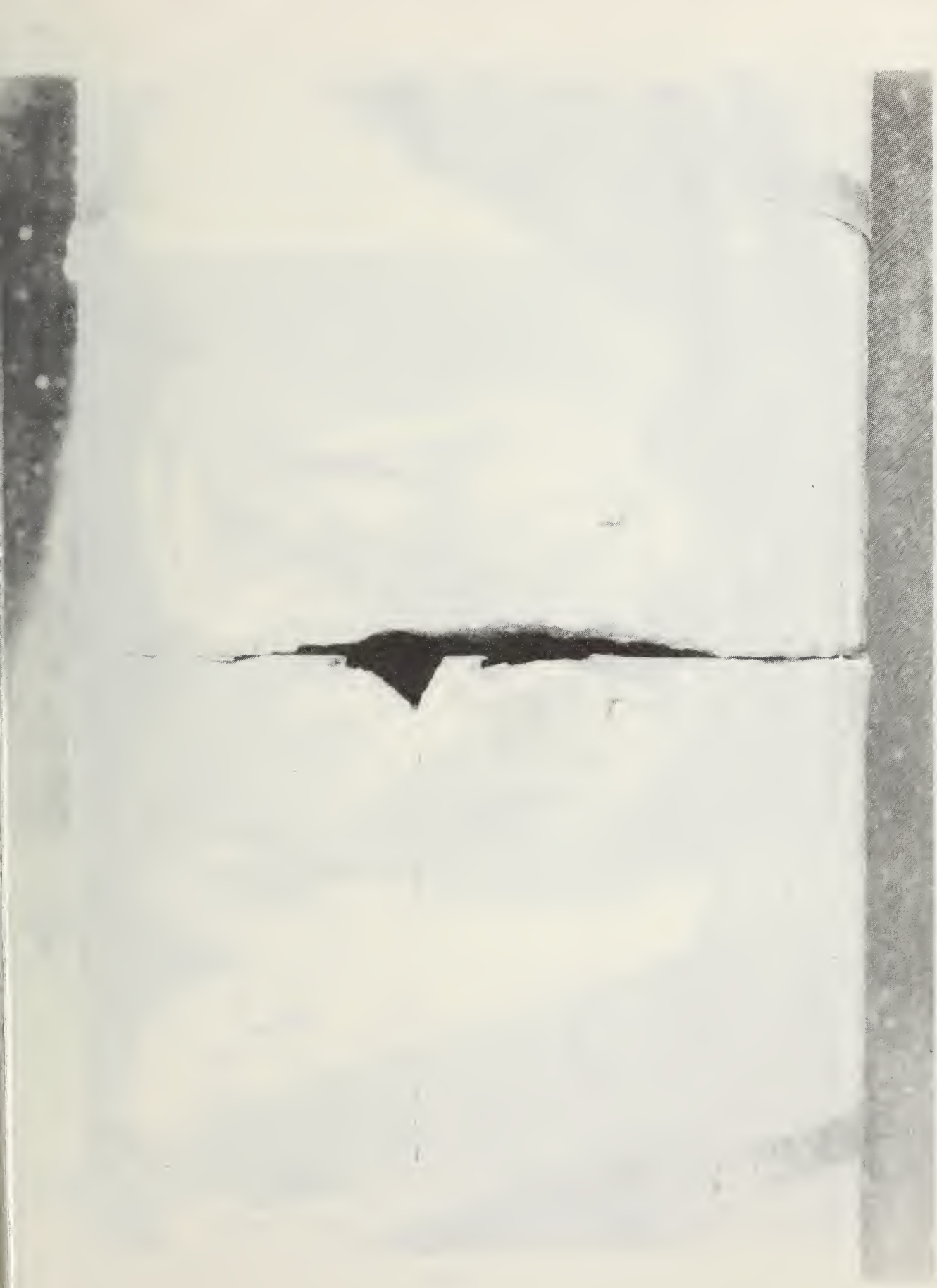

Figure 35. The joint of KAYLO-10 insulation jacket was eroded out by the boiling action of water outside the carrier pipe.



Figure 34. KAYLO-10 insulation after the boiling tests shows severe erosion due to the boiling action.



Figure 36. Crumbs of KAYLO-10 insulation found in the conduit space after the carrier pipe and insulation jacket were removed.

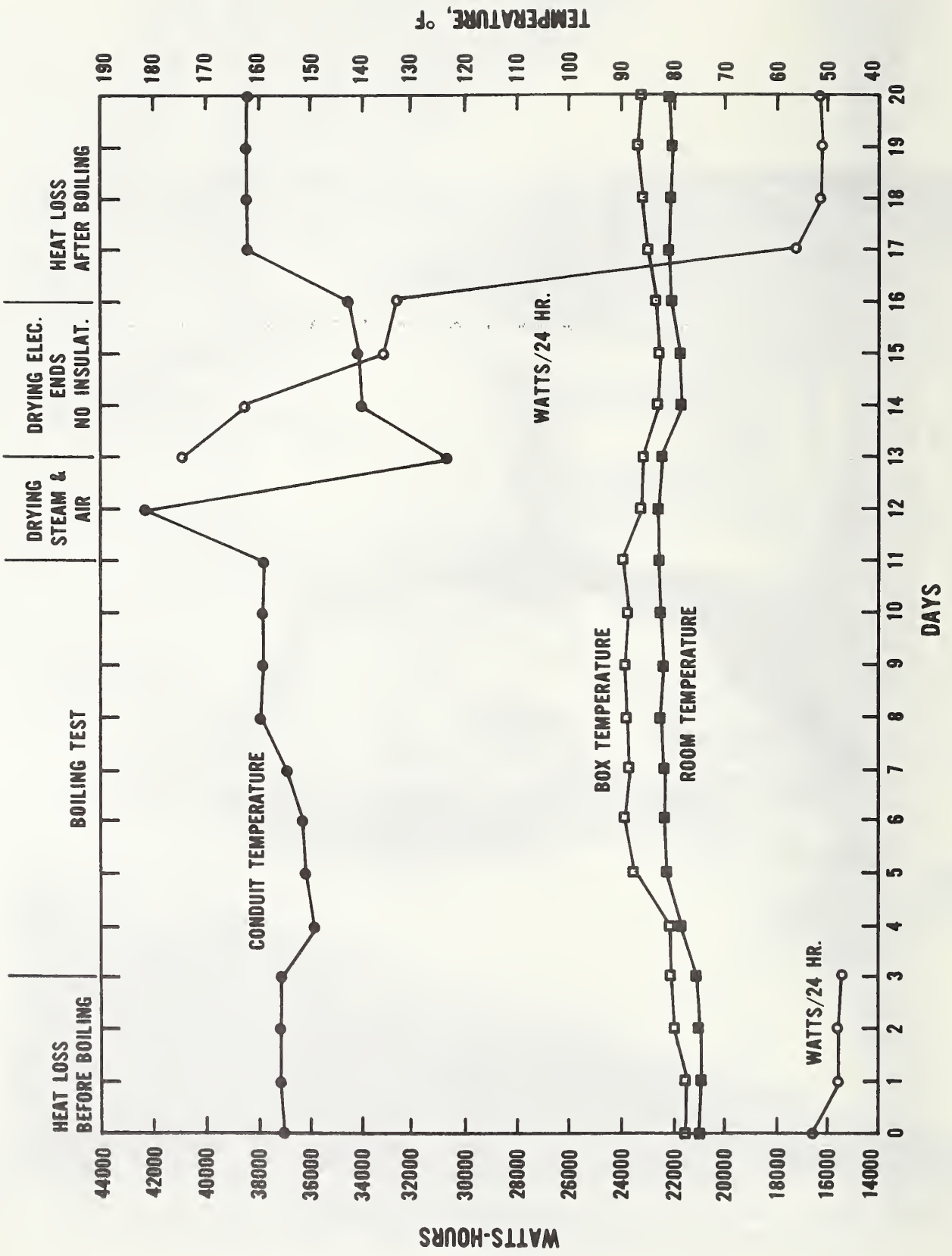

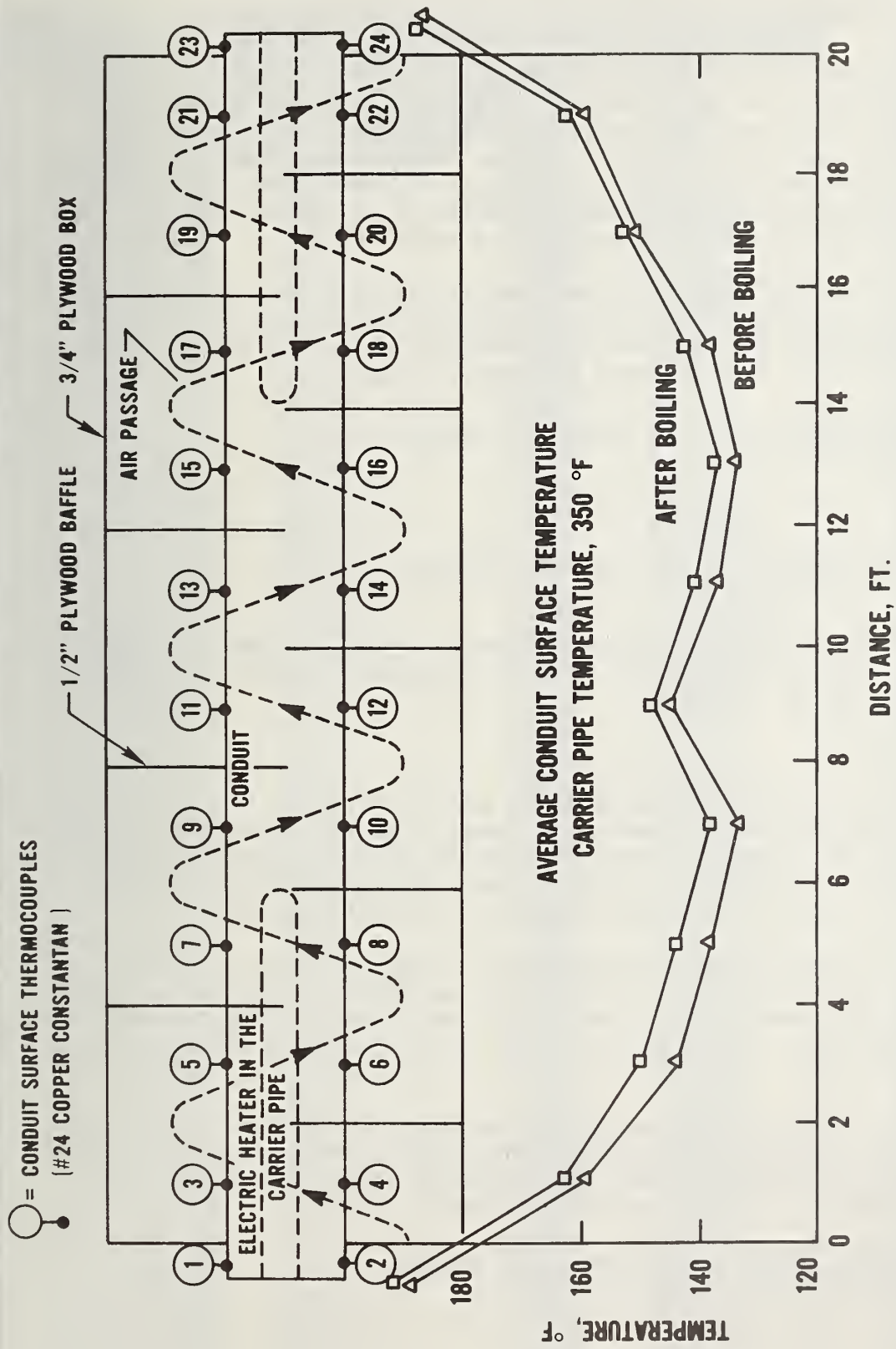

Figure 38. Longitudinal distribution of the conduit temperature before and after the Thermo-12 boiling test.

The insulation removed from the conduit after boiling for 192 hours and drying is shown in figure 39. It can be seen at each end of the sections that the insulation scaled and flaked away slightly from the pipe, which would cause the heat loss rate to increase; also in figure 39 are shown cracks in the insulation that indicate that with continued boiling the insulation could break and fall off of the pipe. Figure 40 shows the waterline during boiling, the bands cut into the insulation, and pitting along the water line.

The longitudinal average conduit surface temperatures for pre- and post-boiling tests obtained from figure 38 are 155.4°F and 160.6°F, respectively. Assuming the pipe temperature to be 350°F and pipe length at 20 ft, the overall pipe heat transfer factor of C in the unit of Btu/h.ft.F is:

$$C = \frac{(3.413)(656)}{(20)(350-155.4)} = 0.575 \text{ before the boiling}$$

and

$$C = \frac{(3.413)(674)}{(20)(350-160.6)} = 0.607 \text{ after the boiling.}$$

The pipe heat transfer factor for this particular underground system, therefore, increased less than 10 percent. The system is considered to have passed the Tri-Service boiling test criteria.

2.5.3 Pabco System

The heat loss before the 192-hr boiling test was 670 watts, and after the boiling test it was 689 watts, based on at least 24 hours of steady conditions. Temperatures and heat transfer during the test are shown in figure 41. The surface temperature distribution profiles along the conduit during the heat loss tests before and after boiling tests are shown in figure 42.

The insulation removed from the conduit after boiling for 192 hours and drying is shown in figure 43. It can be seen that a few portions of insulations were inflated upward against the conduit and cracked. This inflated and cracked condition can be observed on each of five sections along the 20-ft test pipe (figure 44).

The longitudinal average conduit surface temperatures for pre- and post-boiling tests obtained from figure 42 are 155.4°F and 160.6°F, respectively. Assuming the pipe temperature to be 350°F and pipe length at 20 ft, the overall pipe heat transfer factor of C in the unit of Btu/h.ft.F is:

$$C = \frac{(3.413)(670)}{(20)(350-159.8)} = 0.601 \text{ before the boiling}$$

and

$$C = \frac{(3.413)(689)}{(20)(350-161.9)} = 0.625 \text{ after the boiling.}$$

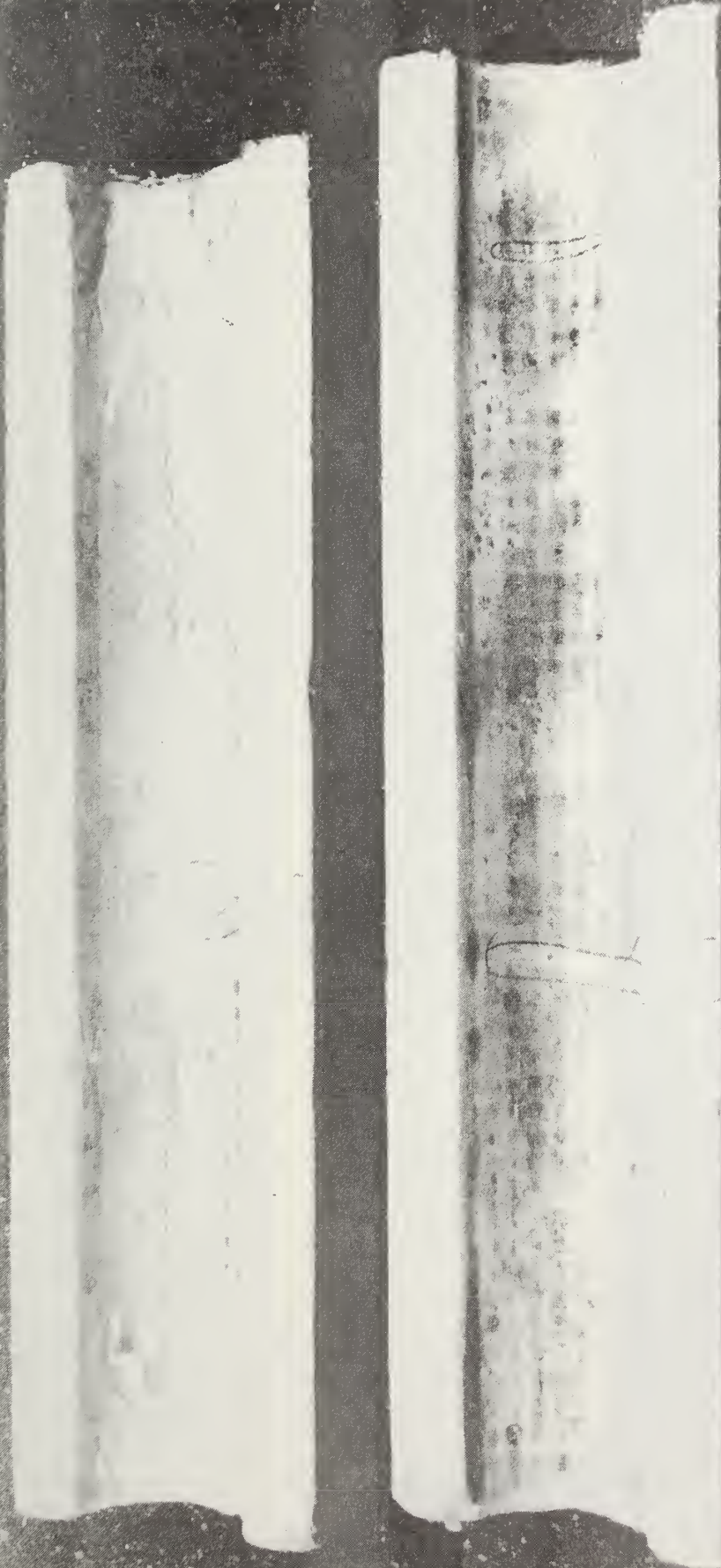

Figure 39. Thermo-12 insulation removed from the conduit after boiling for 192 hours and drying.

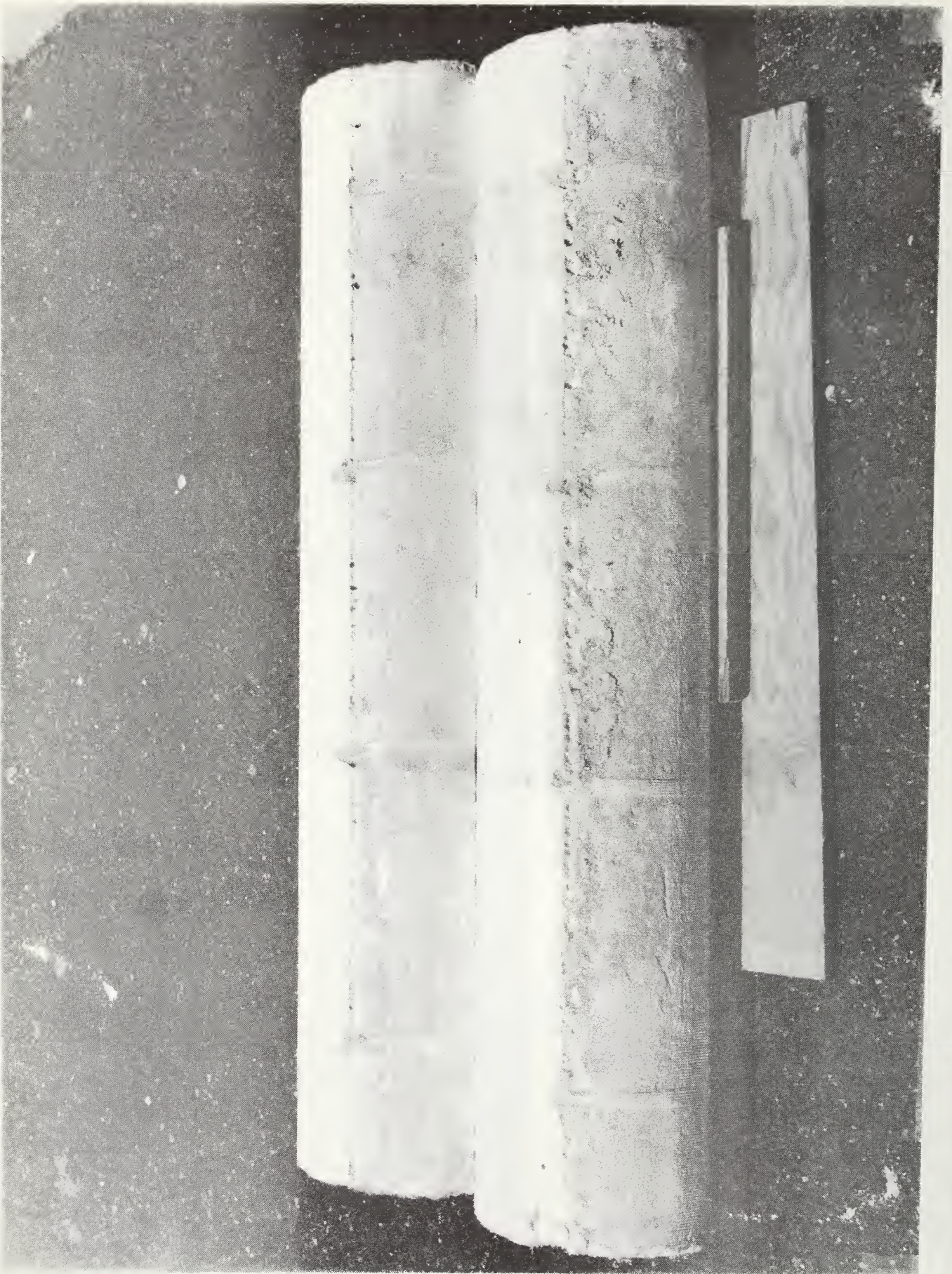

Figure 40. The waterline during the conduit boiling of the Thermo-12 system.

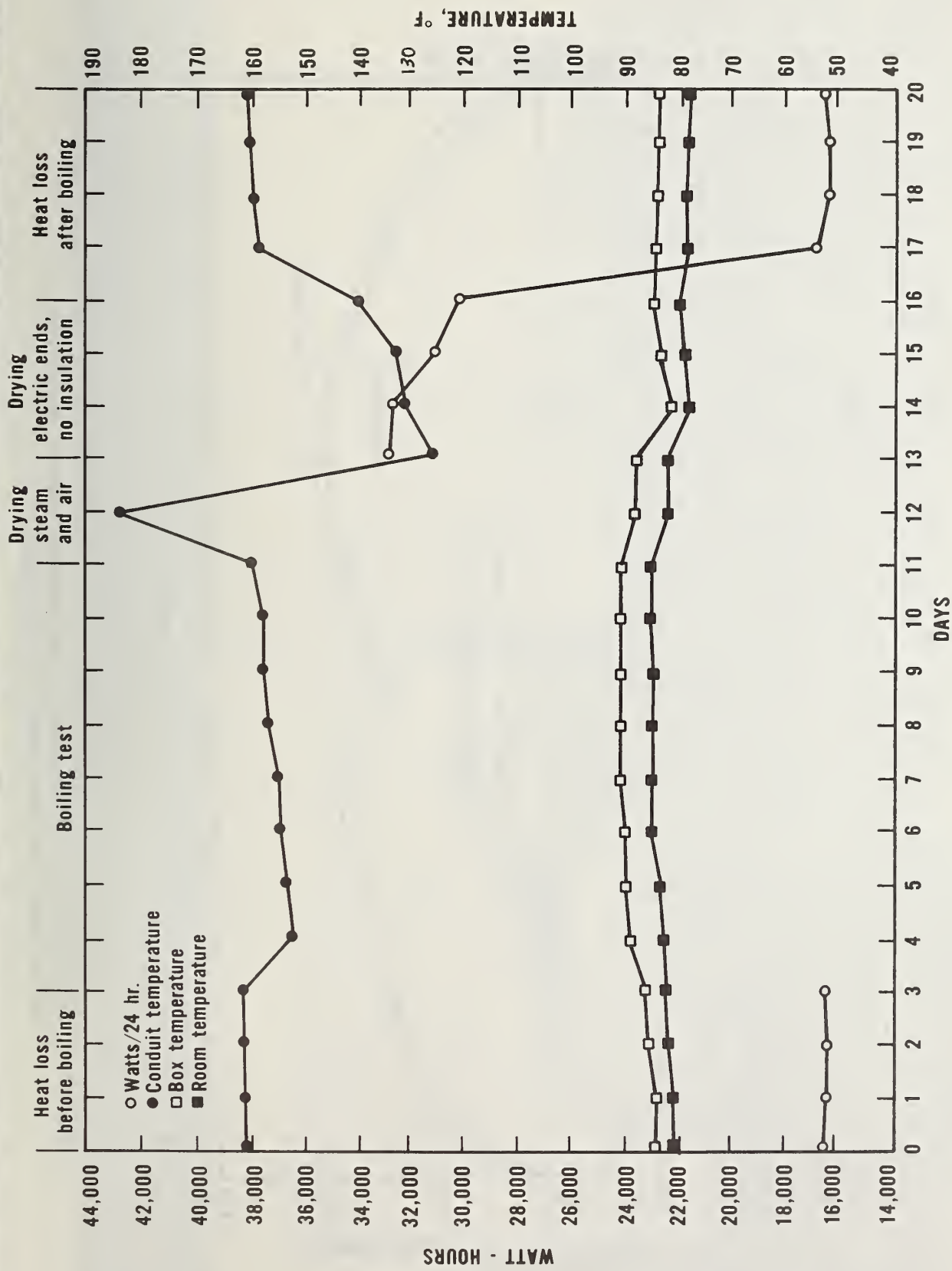

Figure 41. Heat loss and temperature data during the boiling test of PABCO system.

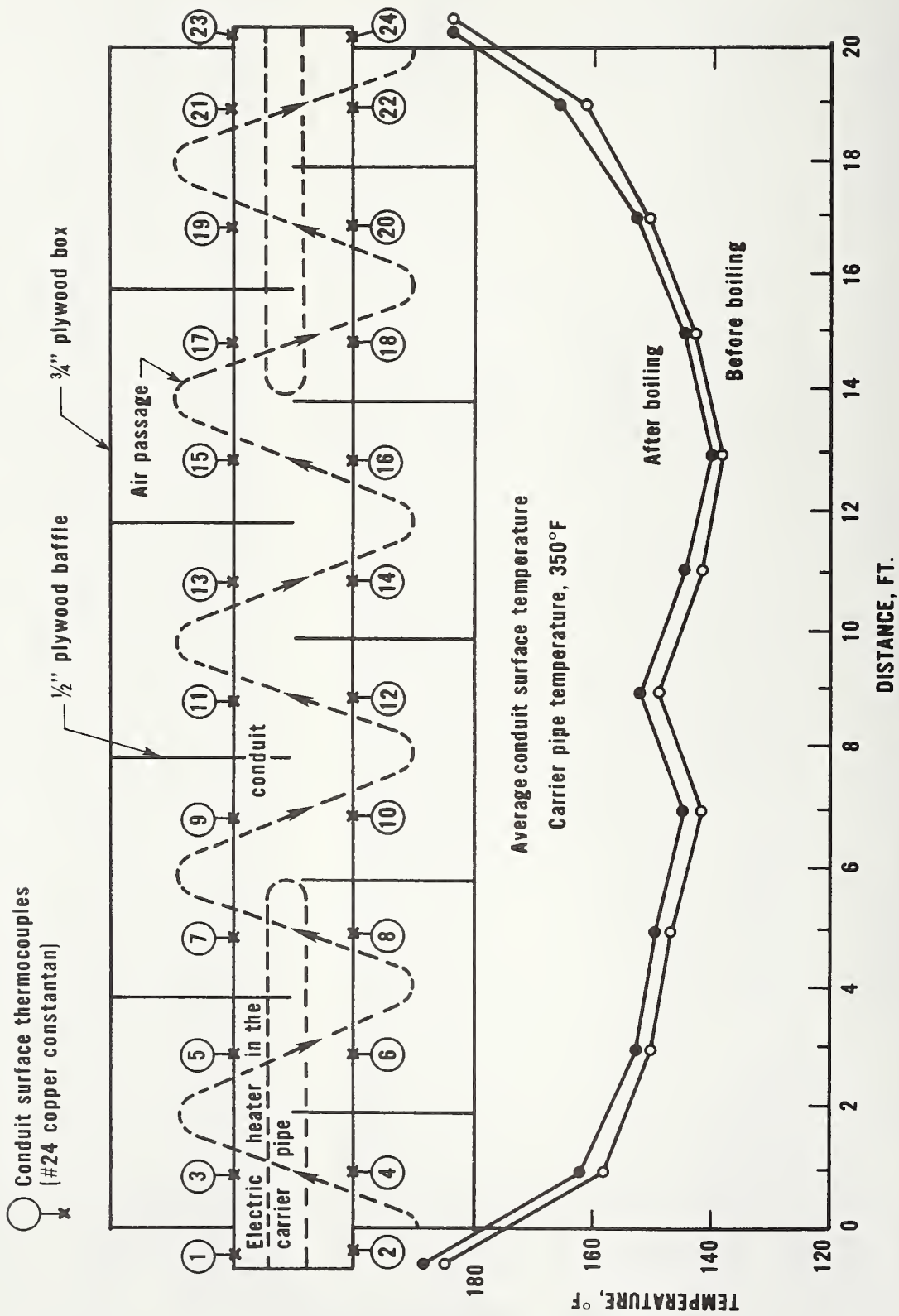

Figure 42. Longitudinal distribution of the conduit surface temperature before and after the PABCO boiling tests.

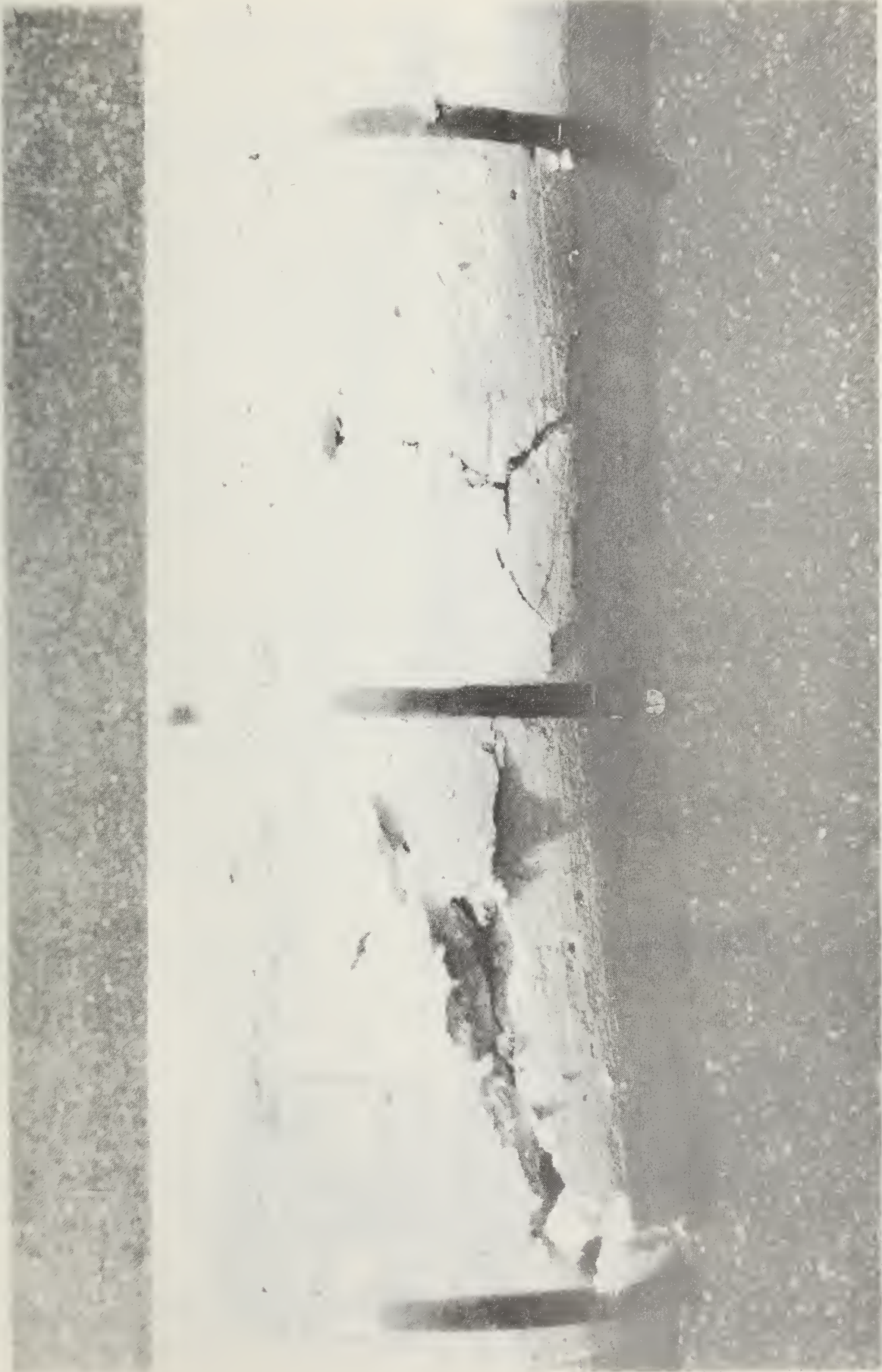

Figure 43. The insulation damage due to 192 hours conduit boiling test and subsequent drying (PABCO system).



Figure 44. The PABCO thermal insulation system immediately after removal from the conduit where it underwent 192 hours boiling and subsequent drying tests.

The pipe heat transfer factor for this particular underground system, therefore, increased less than 10 percent. The system is, however, considered to have failed to meet the TRI-service criteria on account of the physical damage incurred during the boiling.*

2.5.4 Wesolite System

The heat loss before the 96-hr boiling test was 746 watts, and after the boiling test it was 781 watts, based on at least 24 hours of steady conditions. Temperatures and heat transfer during the test are shown in figure 45. The surface temperature distribution profiles along the conduit during the heat loss tests before and after boiling tests are shown in figure 46.

The insulation removed from the conduit after boiling for 96 hours and drying is shown in figure 47. It can be seen at a number of places that the insulation had openings at the joints. Figures 48 and 49 show close-ups of the openings and also the deterioration of the insulation below the water level during boiling. The insulation at the top (above water level) of the pipe was very easy to crumble and could not be taken off the pipe without breaking up (figure 50).

The longitudinal average conduit surface temperatures for pre- and post-boiling tests obtained from figure 46 are 149.6°F and 150.4°F, respectively. Assuming the pipe temperature to be 350°F and pipe length at 20 ft, the overall pipe heat transfer factor of C in the unit of Btu/h.ft.°F is:

$$C = \frac{(3.413) (746)}{(20) (350-149.6)} = 0.635 \text{ before the boiling}$$

and

$$C = \frac{(3.413) (781)}{(20) (350-150.4)} = 0.667 \text{ after the boiling.}$$

The pipe heat transfer factor for this particular underground system, therefore, increased less than 10 percent. The system is considered to have failed the Tri-service criteria on account of the physical damages incurred during the boiling. A water repellent was added later to help correct the crumbling and loss of hardness in the insulation after this test had been completed.

2.5.5 Epitherm System

The heat loss before the 96-hr boiling test was 634 watts, and after the boiling test it was 656 watts, based on at least 24 hours of steady conditions. Temperatures and heat transfer during the test are shown in figure 51. The surface temperature distribution profiles along the conduit during the heat loss tests before and after boiling tests are shown in figure 52.

* The PABCO later conducted a separate boiling test at a private laboratory following the NBS test procedure and successfully met the Tri-service criteria.

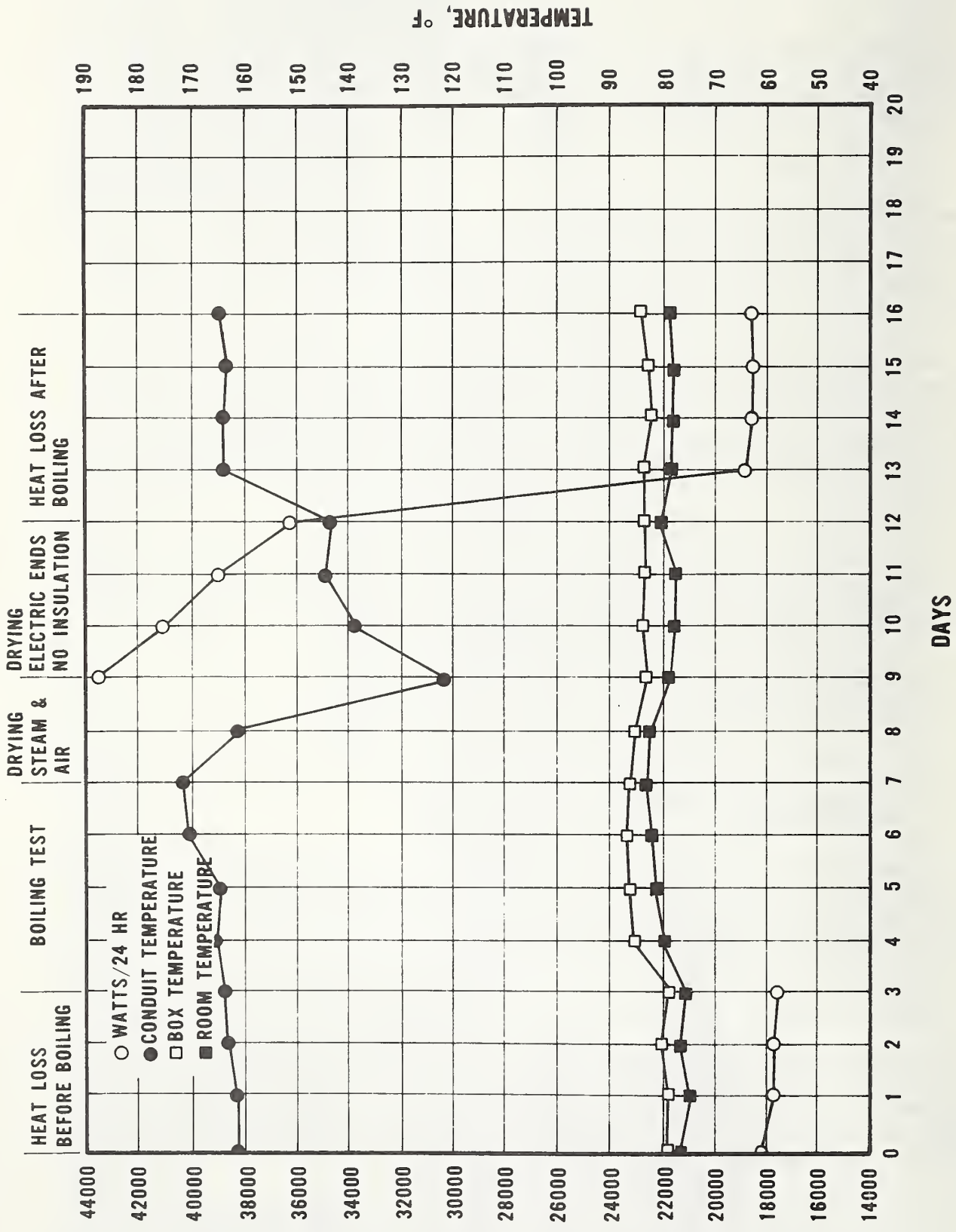

Figure 45. Heat loss and temperature data during the test for Wesolite.

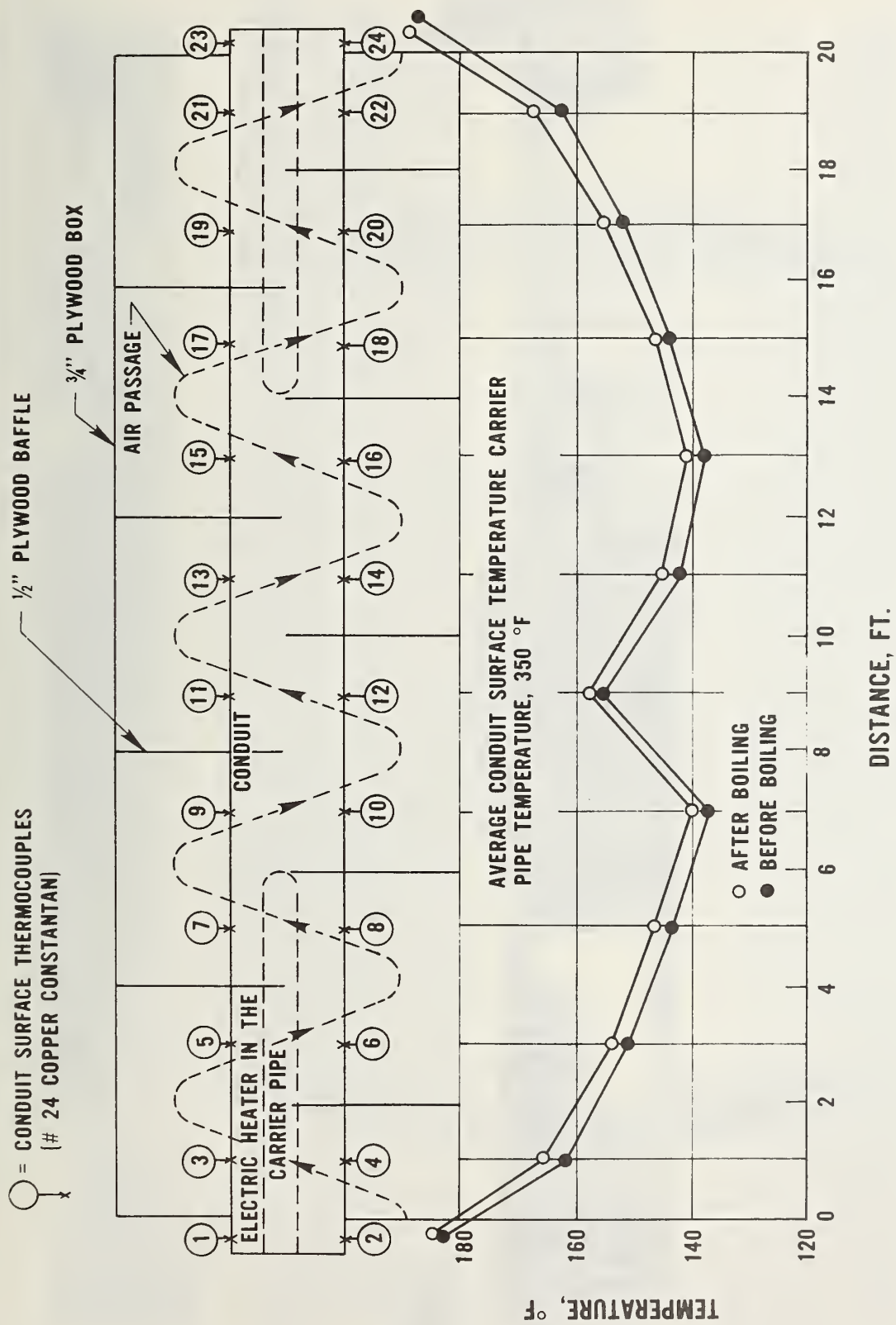

Figure 46. Longitudinal distribution of the conduit surface temperature before and after the boiling tests for Wesolite system.

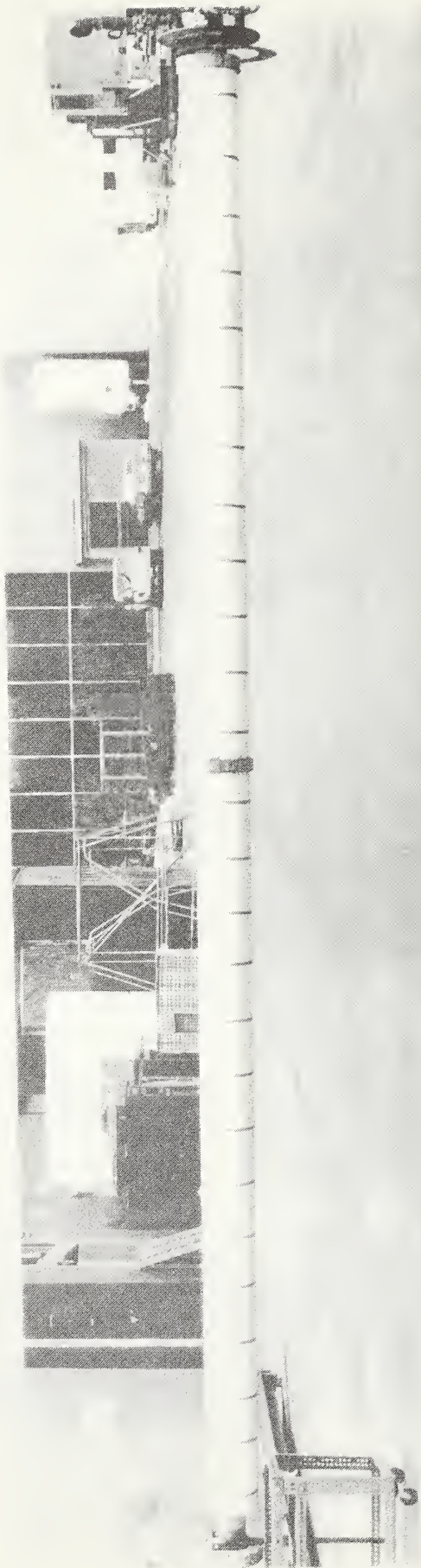

Figure 47. Wesolite on pipe after removal from conduit after 96 hours of boiling.



Figure 48. Close-up of opening at joint after conduit boiling of Mesolite.

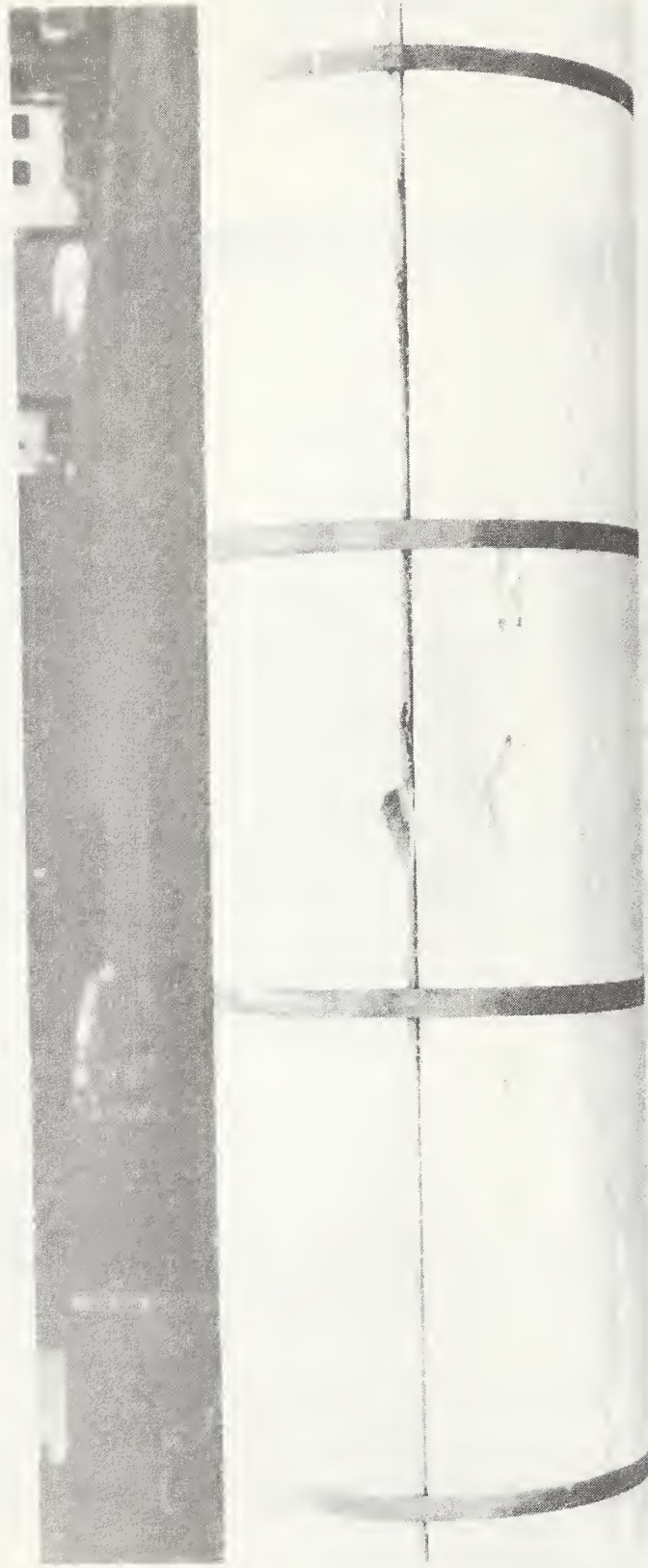
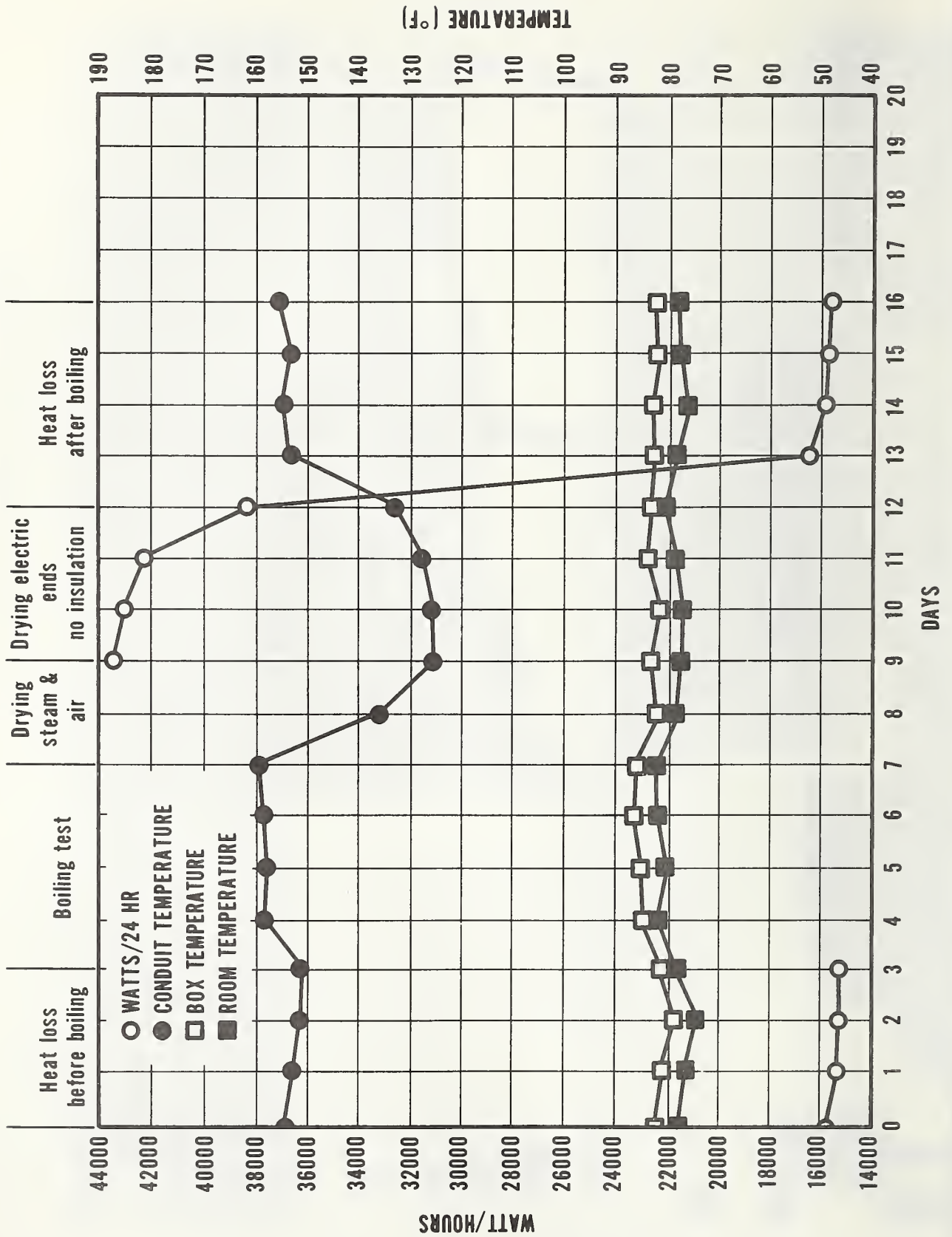

Figure 49. Wesolite after boiling showing deterioration at the bottom of pipe below the water level.



Figure 50. Condition of Wesolite after removal from pipe after boiling.



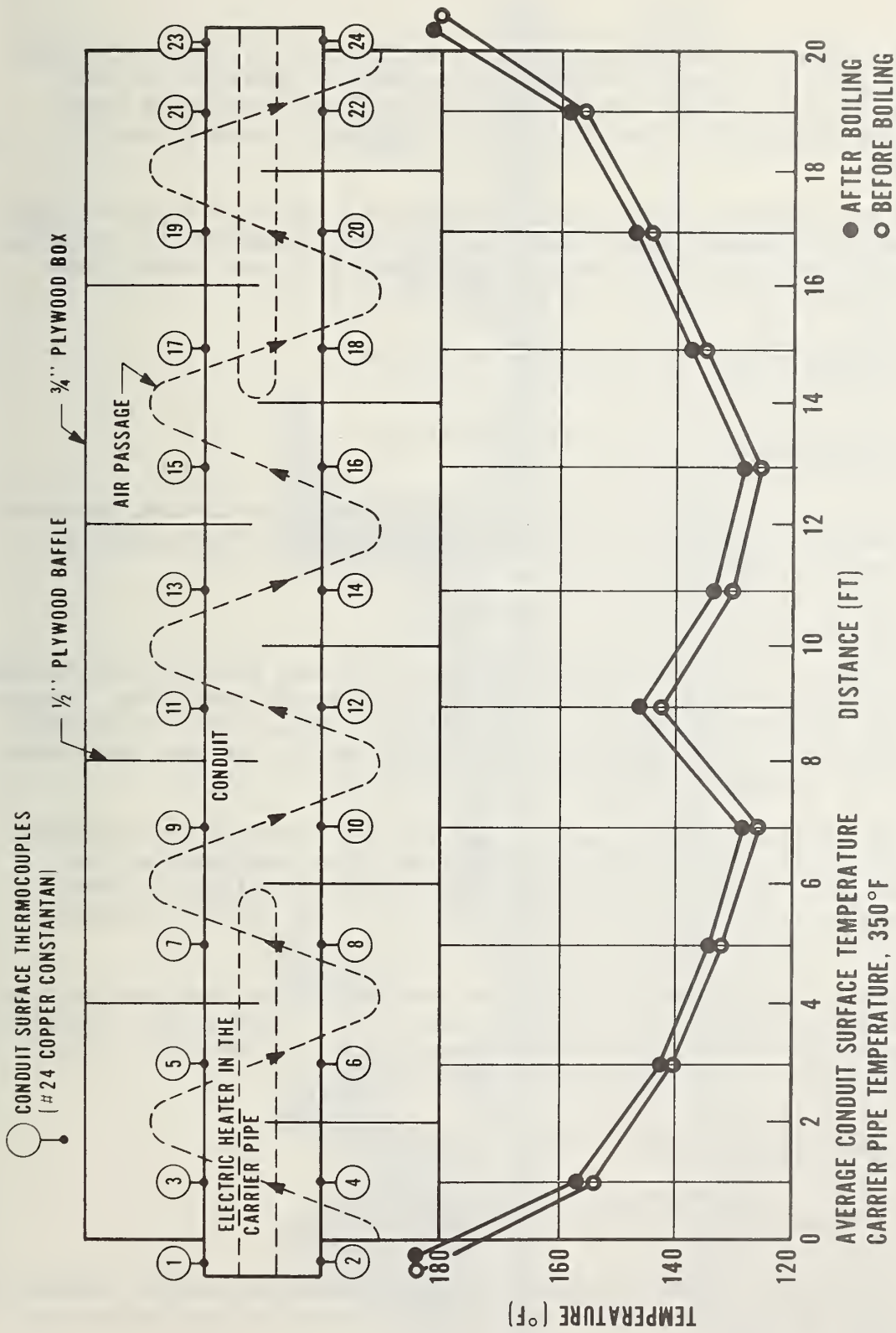

Figure 52. Longitudinal distribution of the conduit surface temperature before and after the boiling test of Epitherm

The insulation removed from the conduit after boiling for 96 hours and drying is shown in figure 53. Figure 54 shows close-up of the insulation at the bottom of the pipe (below the water level) after boiling. Figure 55 shows close-up of the insulation at the top of the pipe (above the water level) after boiling.

The longitudinal average conduit surface temperatures for pre-and post-boiling tests obtained from figure 52 are 139.2°F and 140.1°F, respectively. Assuming the pipe temperature to be 350°F and pipe length at 20 ft, the overall pipe heat transfer factor of C in the unit of Btu/h.ft.°F is:

$$C = \frac{(3.413) (634)}{(20) (350-139.2)} = 0.472 \text{ before the boiling}$$

and

$$C = \frac{(3.413) (656)}{(20) (350-140.1)} = 0.490 \text{ after the boiling.}$$

The pipe heat transfer factor for this particular underground system, therefore, increased less than 10 percent. The system is considered to have passed the Tri-Service boiling test.

2.5.6 Celotemp System

The heat loss before the 96-hr boiling test was 725 watts, and after the boiling test it was 782 watts, based on at least 24 hours of steady conditions. Temperatures and heat transfer during the test are shown in figure 56. The surface temperature distribution profiles along the conduit during the heat loss tests before and after boiling tests are shown in figure 57.

The insulation removed from the conduit after boiling for 96 hours and drying is shown in figure 58. Figure 59 shows close-up of the insulation at the bottom of the pipe (below the water level) after boiling. Figure 60 shows crumbs of insulation found in the conduit space after the carrier pipe and insulation jacket were removed.

The longitudinal average conduit surface temperature for pre- and post-boiling tests obtained from figures 57 are 149.6°F and 157.7°F, respectively. Assuming the pipe temperature to be 350°F and pipe length at 20 ft, the overall pipe heat transfer factor of C in the unit of Btu/h.ft.°F is:

$$C = \frac{(3.413) (725)}{(20) (350-149.6)} = 0.617 \text{ before the boiling}$$

and

$$C = \frac{(3.413) (782)}{(20) (350-157.7)} = 0.694 \text{ after the boiling.}$$

The pipe heat transfer factor for this particular underground system, therefore, increased more than 10 percent. The system is considered to have failed the Tri-Service boiling test.



Figure 53. Epitherm on pipe after removal from conduit after 96 hours of boiling.

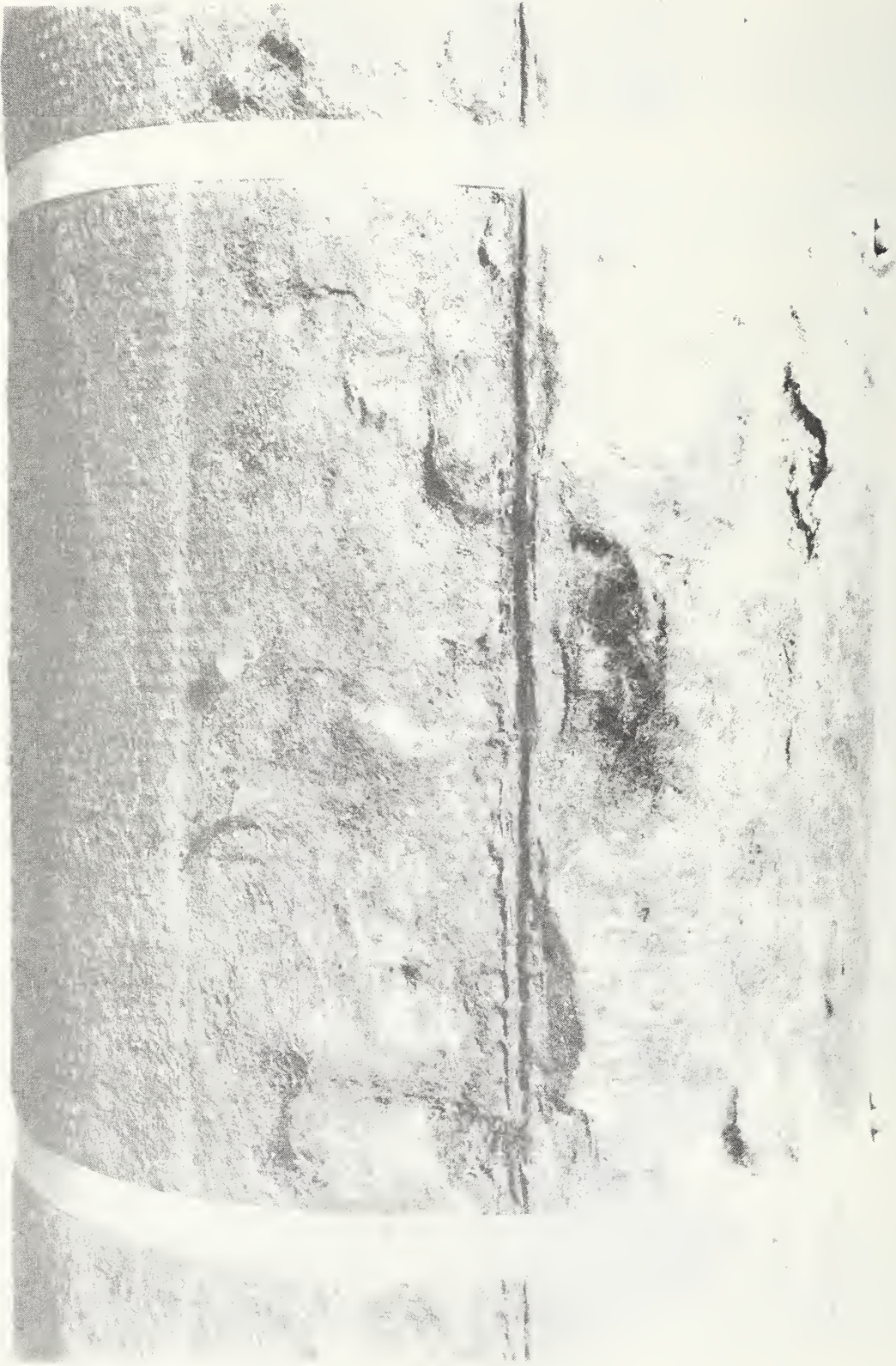

Figure 54. Close-up of Epitherm at the bottom of the pipe after boiling (below the water level).

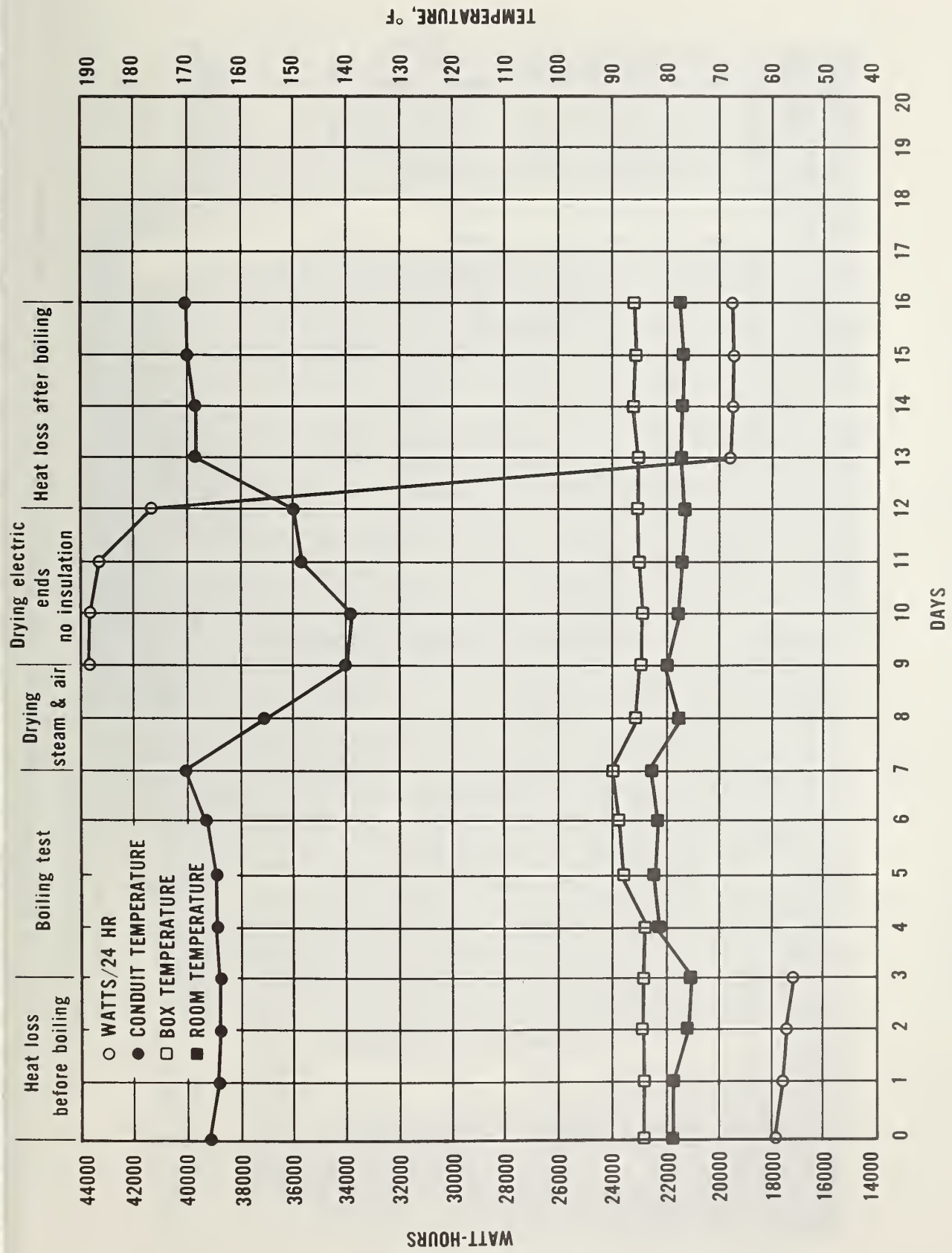

Figure 56. Heat loss and temperature data during the test of the Celotemp system.



Figure 55. Close-up of Epitherm at the top of the pipe after boiling (above the water level).

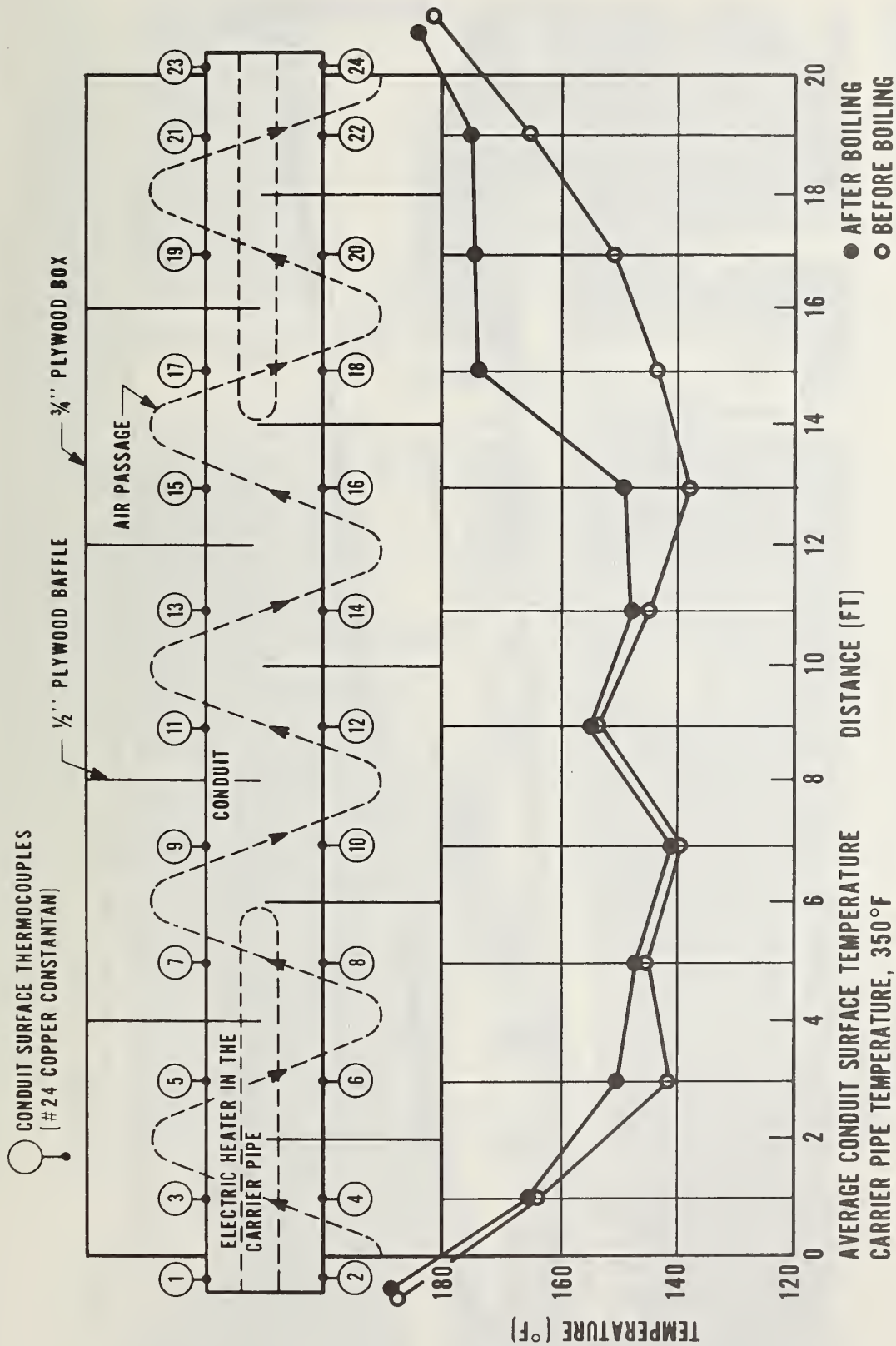

Figure 57. Longitudinal distribution of the conduit surface temperature before and after the boiling test (Celotemp system).



Figure 58. Insulation on the pipe after removal from conduit after 96 hours of boiling.
(Celotemp system).

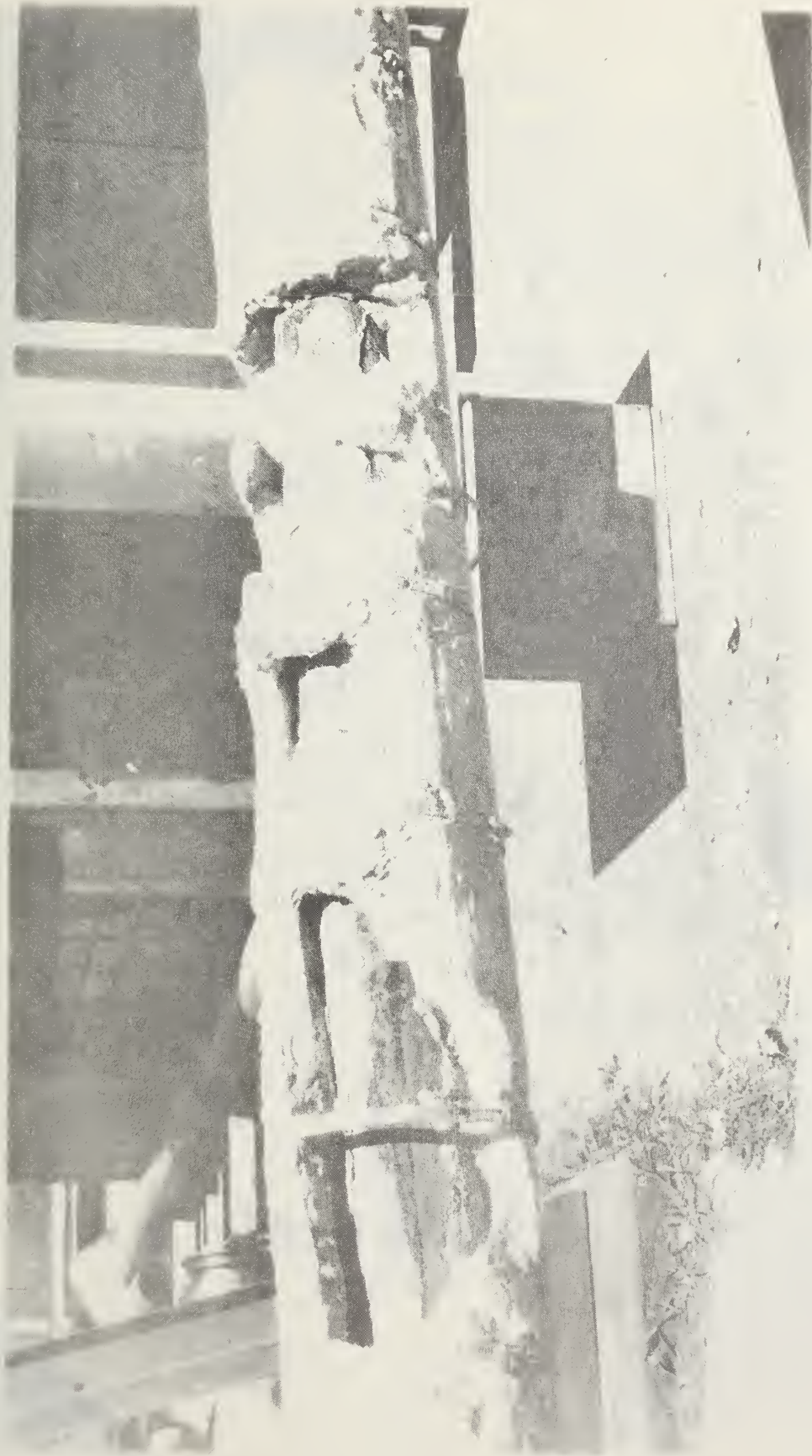

Figure 59. Insulation after boiling showing deterioration at the bottom of the pipe below the water level (Celotemp system).



Figure 60. Crumbs of insulation found in the conduit space after the carrier pipe and insulation jacket were removed (Celotemp system).

3. SIXTY-FOUR-DAY CONDUIT BOILING TEST OF INSULATION

Six different brands of high temperature asbestos-free pipe insulation were installed on the 4-in, 20-ft pipe inside of 10.75-in RIC-WIL conduit. The test was conducted in the same conduit boiling apparatus as described in section 2, except that the conduit was filled to the half-full mark with water and controlled at this level during this 64 days of boiling. The steam pressure in the 4-in pipe was 50 psi, and this caused the water in the conduit to boil during the test.

The purpose of this test was to determine the effect of long periods of boiling on the insulation inside of the conduit. This test was run for 8 days and was stopped to remove the 4-in pipe and insulation from the conduit for examination and for taking photographs. This same procedure was repeated for three more 8-day periods of boiling (32 days total). At the end of 32 days of boiling, the same procedure was repeated for an additional 32 days, a total of 64 days of boiling of the insulation on the 4-in pipe inside of the conduit.

The results of this test are shown on Table 1 with references to photographs. The samples are identified in the photographs by the following numbers:

1. Celotemp 1500, Celotex Corp. Expanded perlite. Figures 61 and 62.
2. Thermo-12, Johns-Manville Co., Calcium silicate. Figures 63-66.
3. Epitherm 1200, Eagle-Picher Co., Mineral wool. Figures 67-71.
4. Wesolite "D", Wesolite Co., Perlite/sodium silicate. Figures 72-76.
5. Super Caltemp, Pabco, Calcium silicate. Figures 77-80.
6. Kaylo-10, Owens/Corning, Calcium silicate. Figures 81-84.

Table 1. Sixty-four-day Conduit Boiling Test of Six Insulation Materials

Insulation Material	Days Boiling			
	8	16	24	32
Celotemp 1500 Celotex Corp. Expanded perlite	Started breaking apart Figure 61	Final run insulation 50% off of pipe. Figure 62	---	---
Thermo-12 Johns-Manville Calcium silicate	No physical damage visible to insulation.	Started to show damage. Figure 63	Increased damage apparent. Figure 64	Continuous damage apparent. Figure 65
Epitherm 1200 Eagle-Picher Mineral wool	Slight damage apparent Figure 67	Slightly increased damage. Figure 68	Damage at support on end. Figure 69	Slight increased damage. Figure 70
Wesolite "D" Wesolite Co. Perlite/sodium silicate	Damage below water level. Figure 72	Joint opening slightly Figure 73	Slight damage at joint. Figure 74	Damage at end of section. Figure 75
Super Caltemp Pabco Calcium silicate	No physical damage visible to insulation.	Cracks visible in insulation. Figure 77	No increase in damage visible. Figure 78	Damage below water level. Figure 79
Kaylo-10 Owens/Corning Calcium silicate	No physical damage visible to insulation.	Slight damage visible. Figure 81	Damage at joint visible. Figure 82	Joint starting to open up. Figure 83
				64



Figure 61. Celotemp 1500 after 8 days boiling.



Figure 62. Celotemp 1500 after 16 days of boiling.

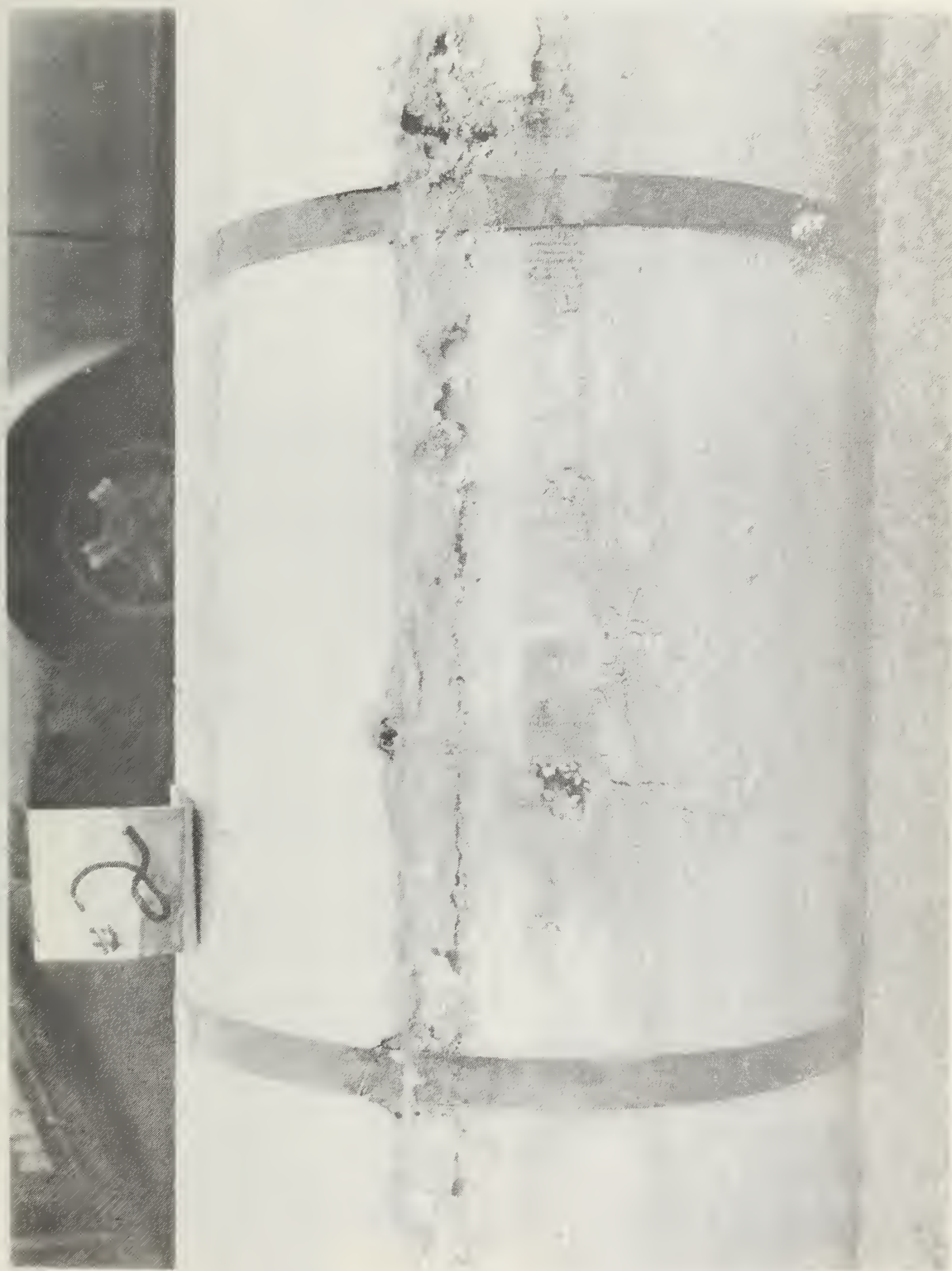

Figure 63. Thermo-12 after 16 days of boiling.



Figure 64. Thermo-12 after 24 days of boiling.



Figure 65. Thermo-12 after 32 days of boiling.



Figure 66. Thermo-12 after 64 days of boiling.



Figure 67. Epitherm 1200 after 8 days of boiling.



Figure 68. Epitherm 1200 after 16 days of boiling.

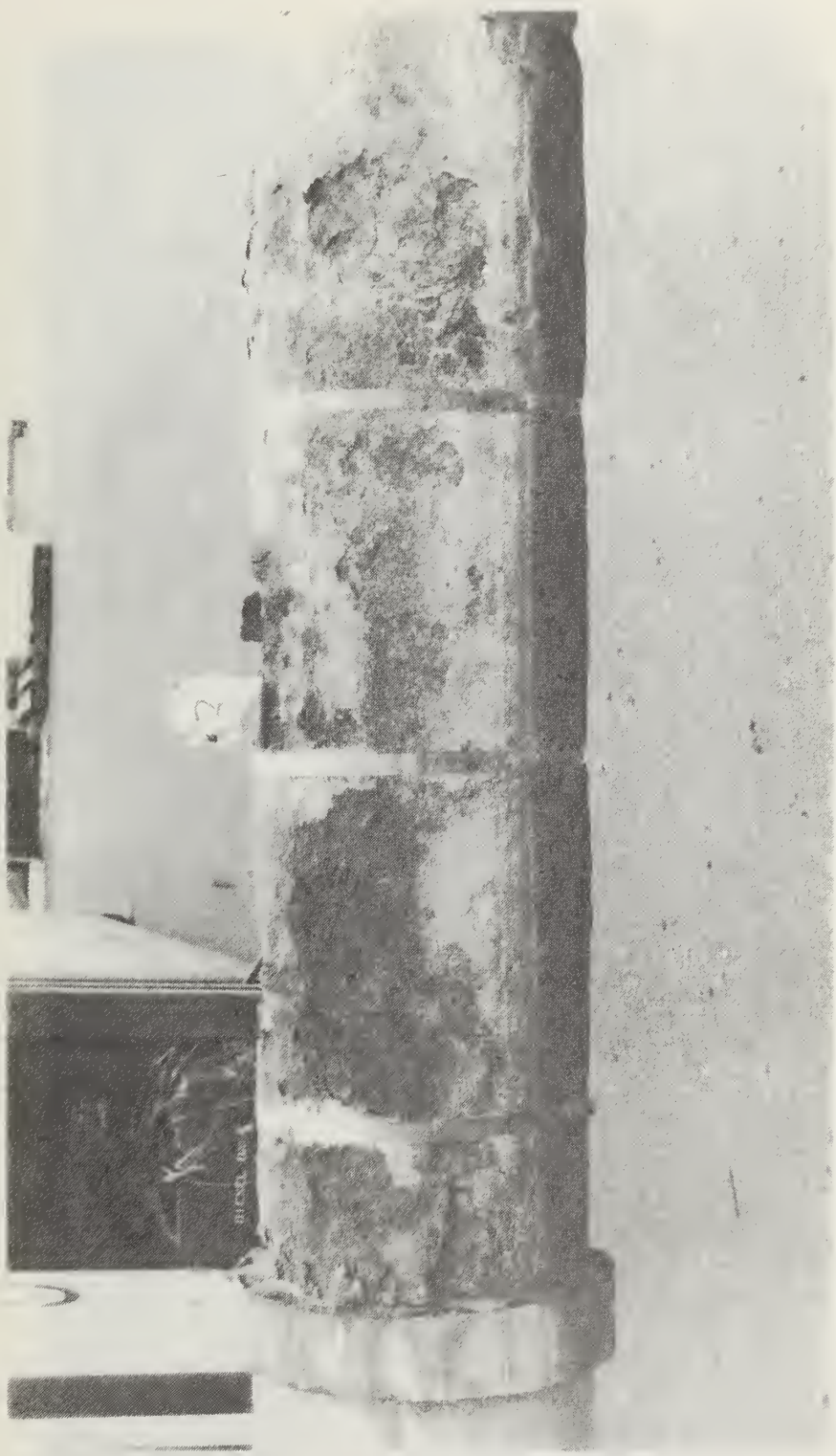

Figure 69. Epitherm 1200 after 24 days of boiling.

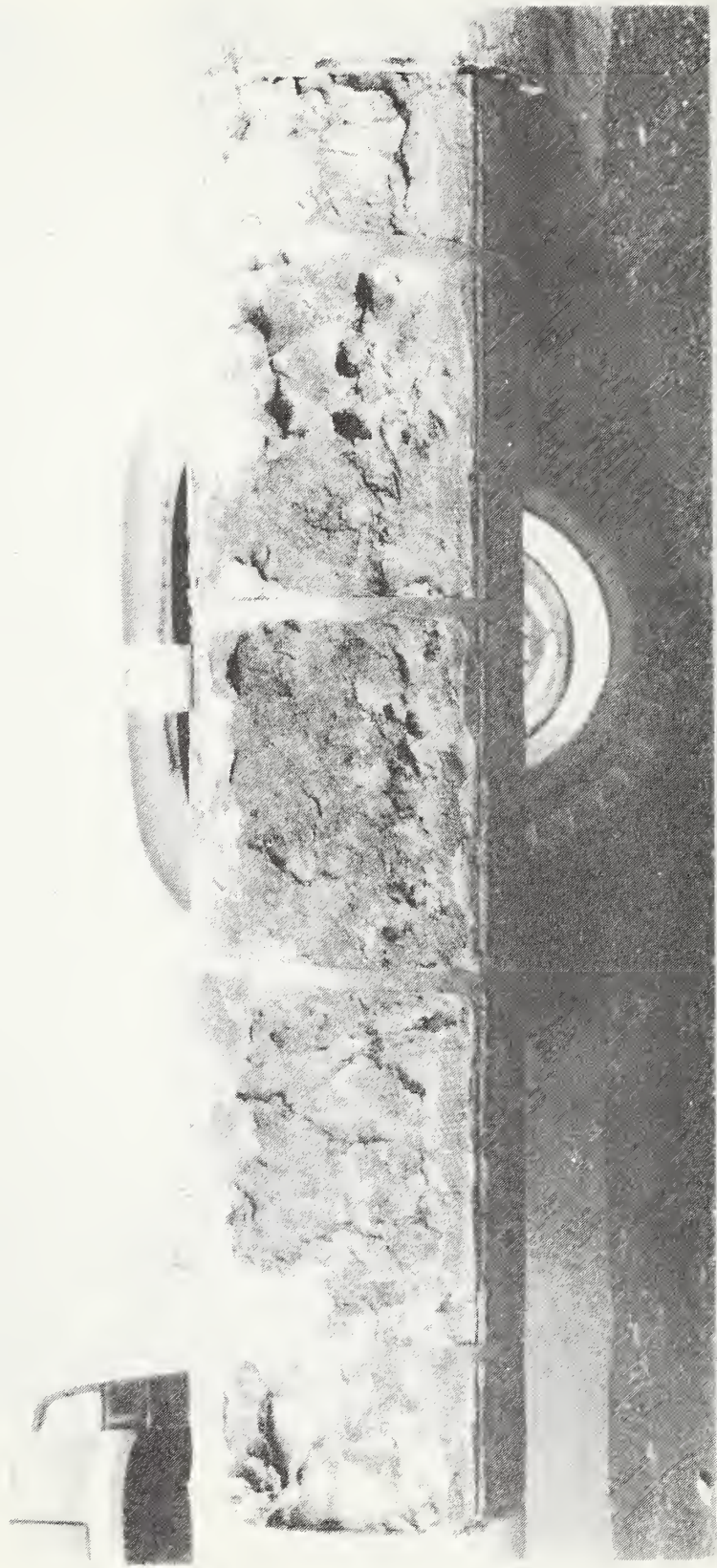

Figure 70. Epitherm 1200 after 32 days of boiling.



Figure 71. Epitherm 1200 after 64 days of boiling.

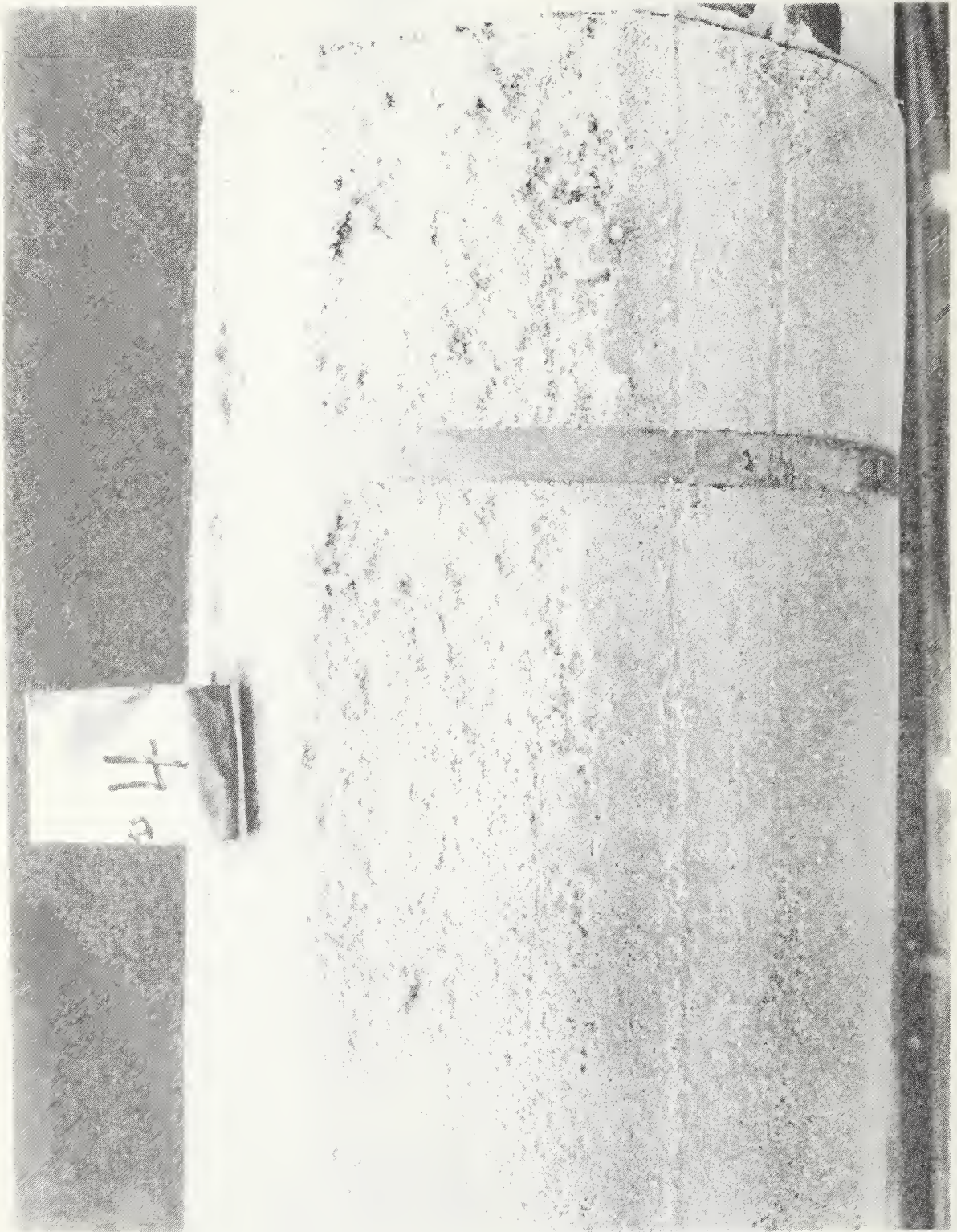

Figure 72. Wesolite "D" after 8 days of boiling.

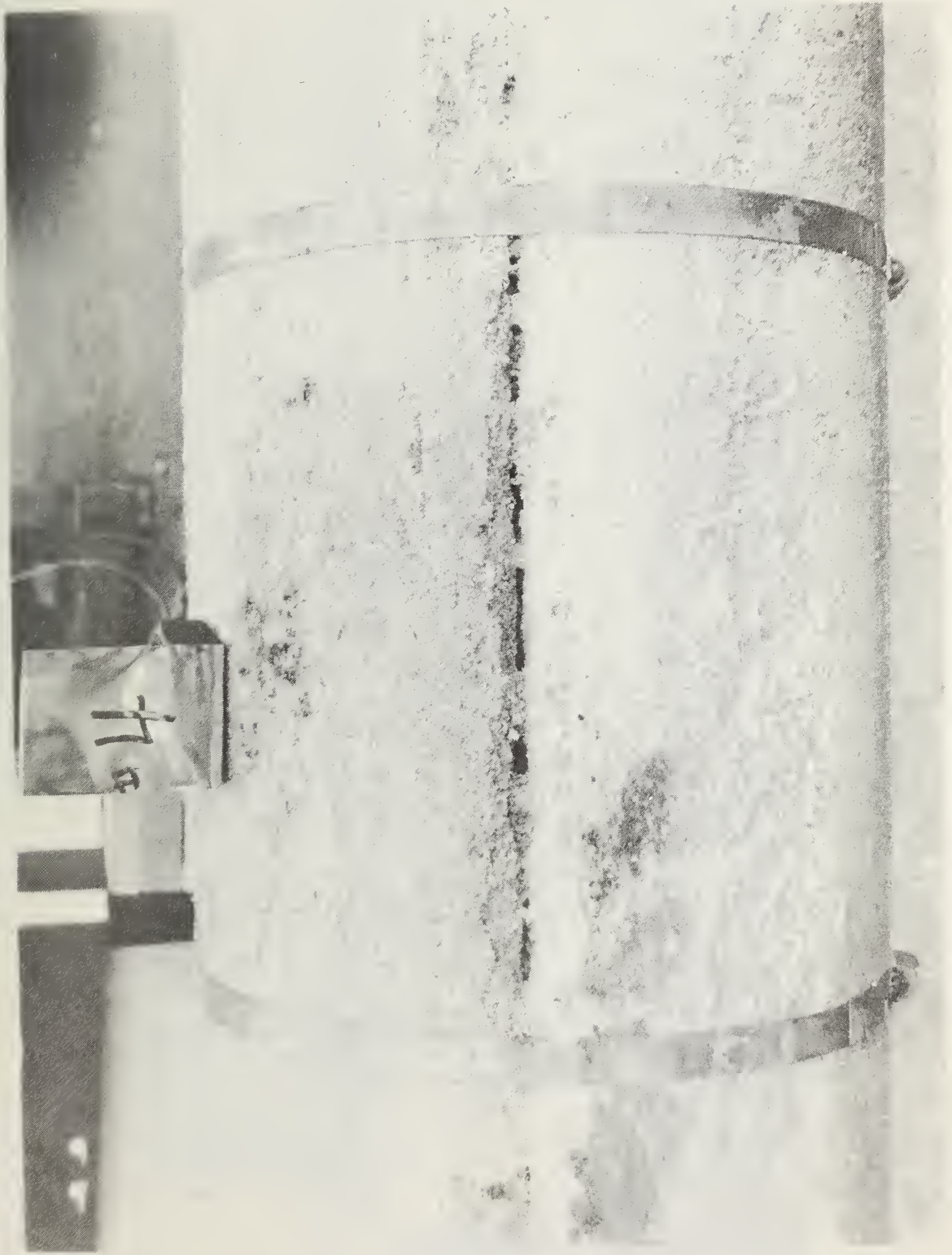

Figure 73. Mesolite "D" after 16 days of boiling.



Figure 74. Wesolite "D" after 24 days of boiling.



Figure 75. Wesolite "D" after 32 days of boiling.



Figure 76. Wesolite "D" after 64 days of boiling.

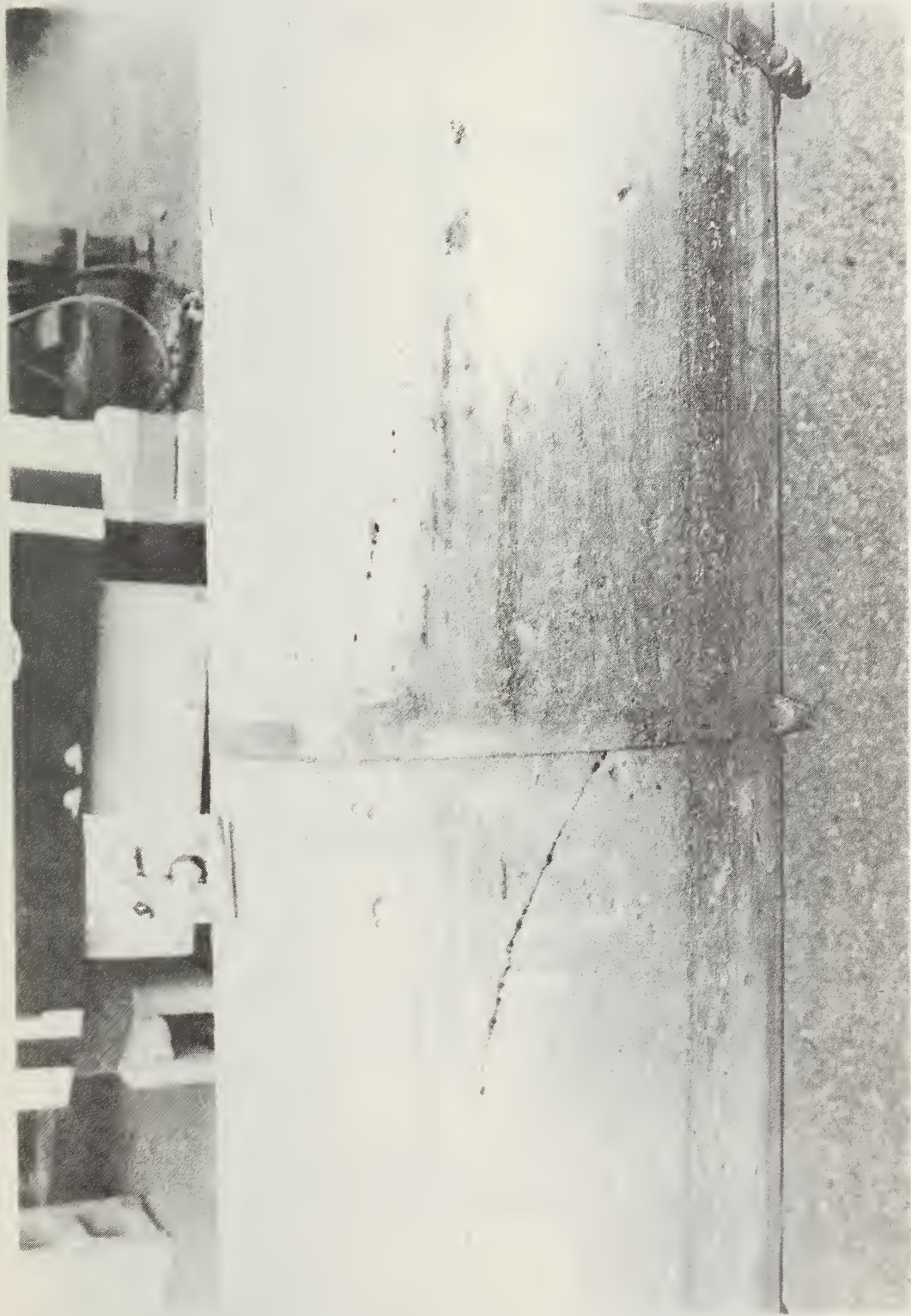

Figure 77. Super Caltemp after 16 days of boiling.



Figure 78. Super Caltemp after 24 days of boiling.

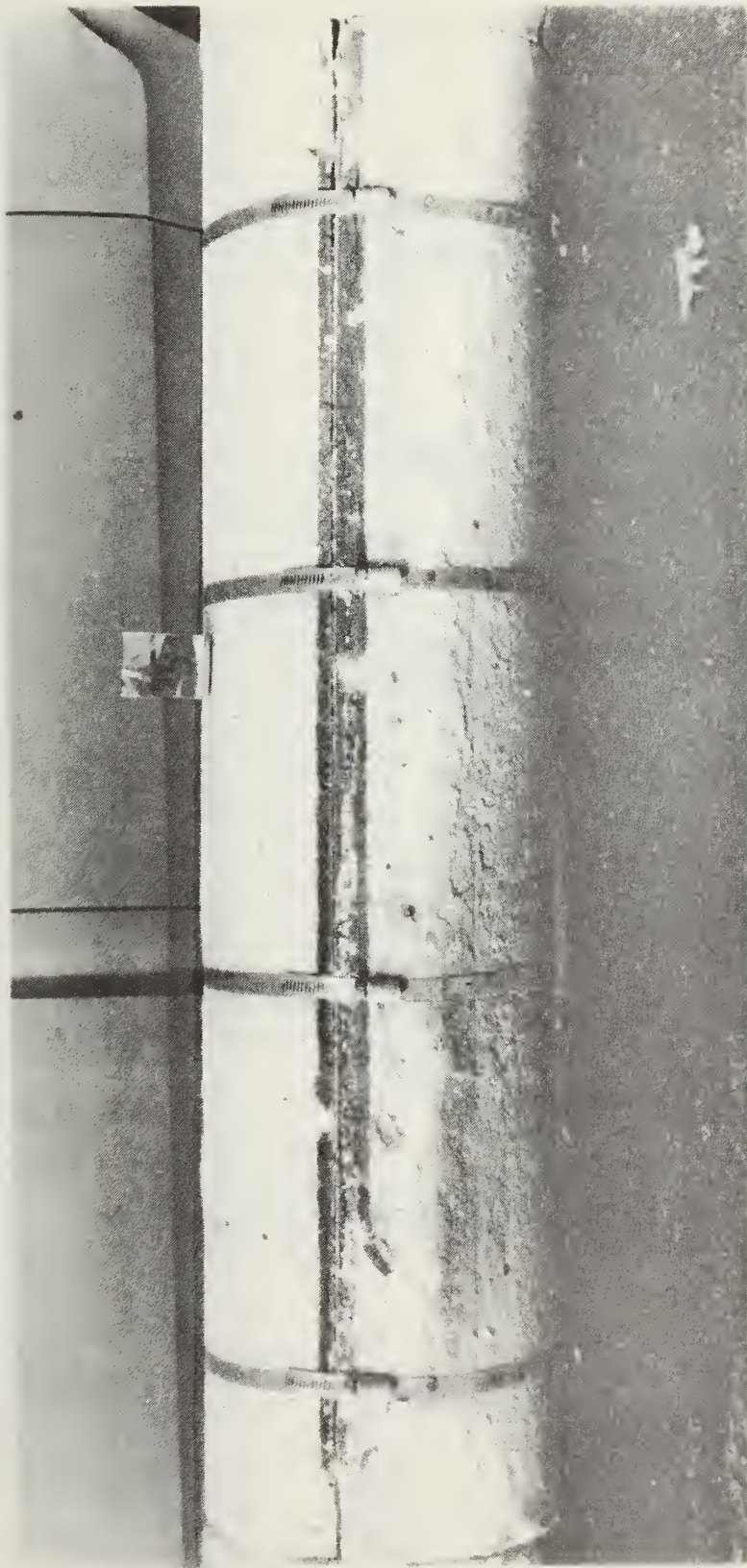

Figure 79. Super Caltemp after 32 days of boiling.



Figure 80. Super Caltemp after 64 days of boiling.

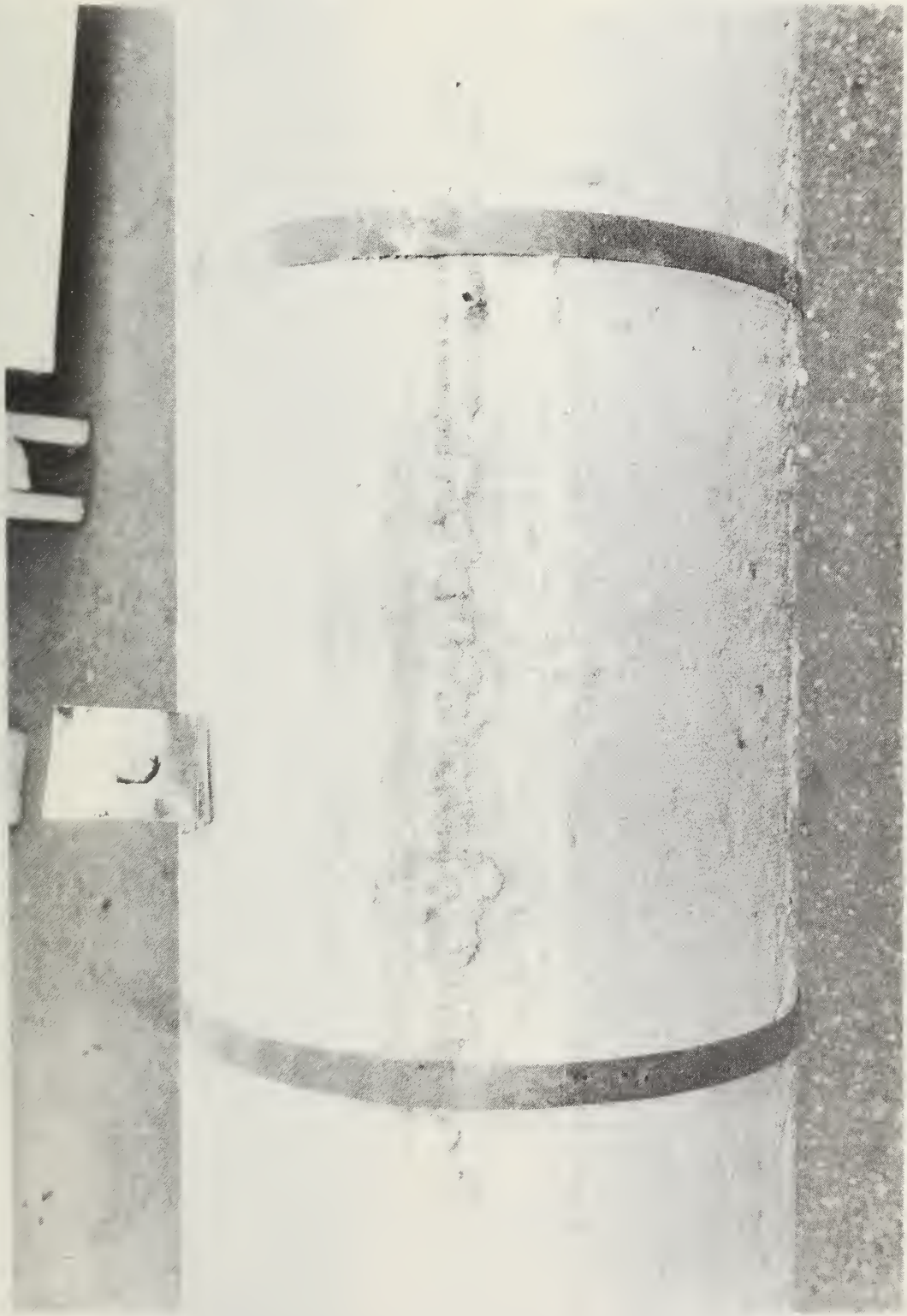

Figure 81. KAYLO-10 after 16 days of boiling.

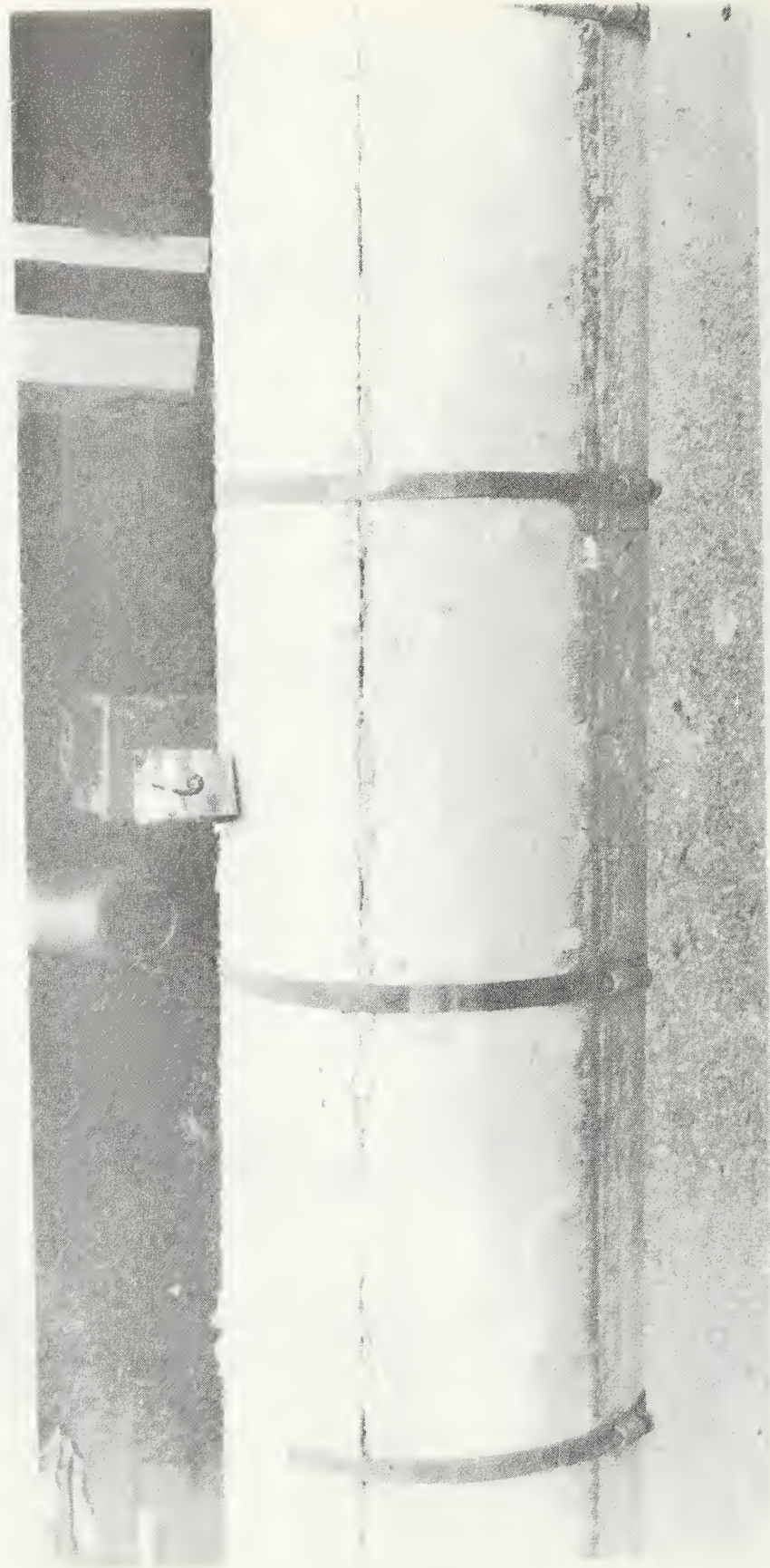

Figure 82. KAYLO-10 after 24 days of boiling.

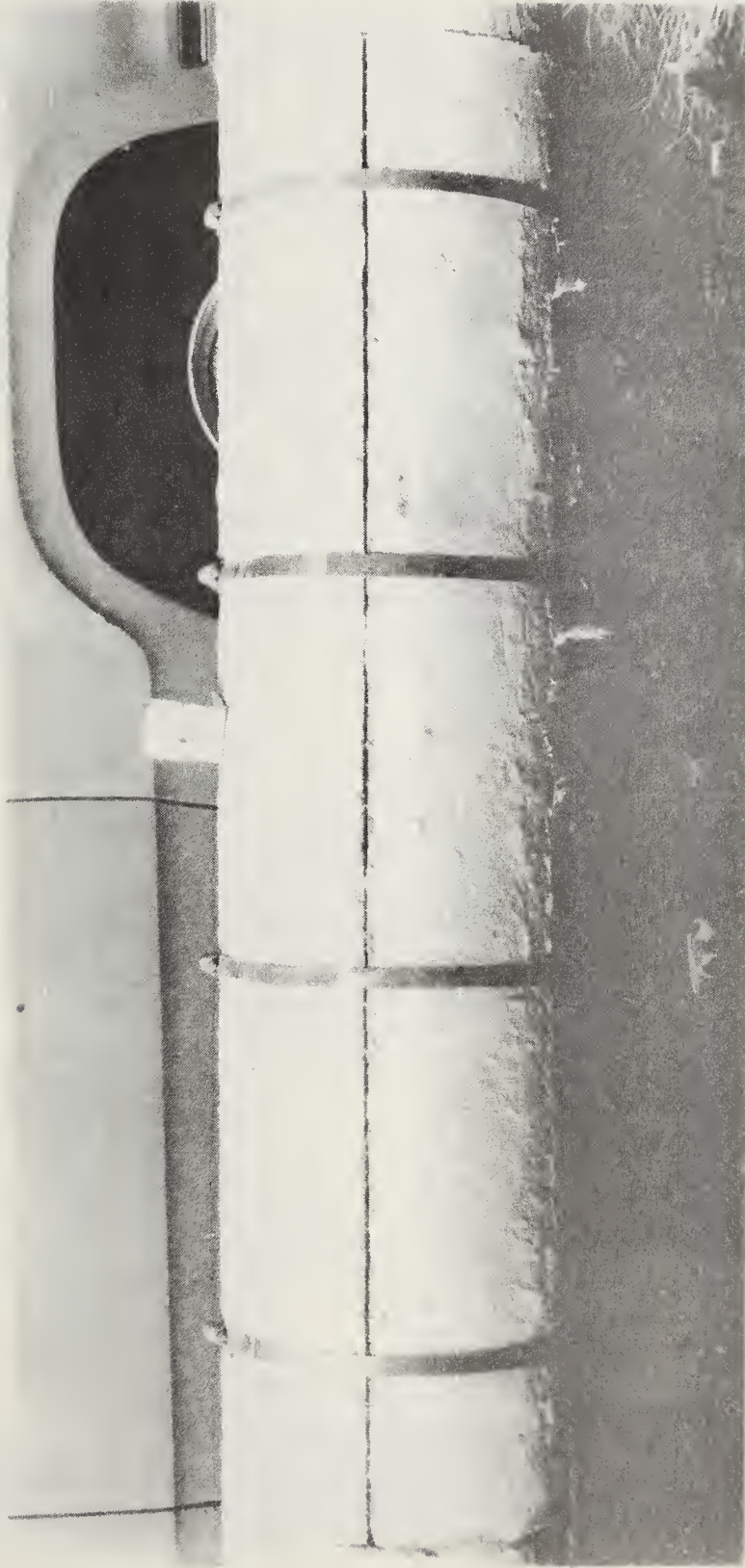

Figure 83. KAYLO-10 after 32 days of boiling.

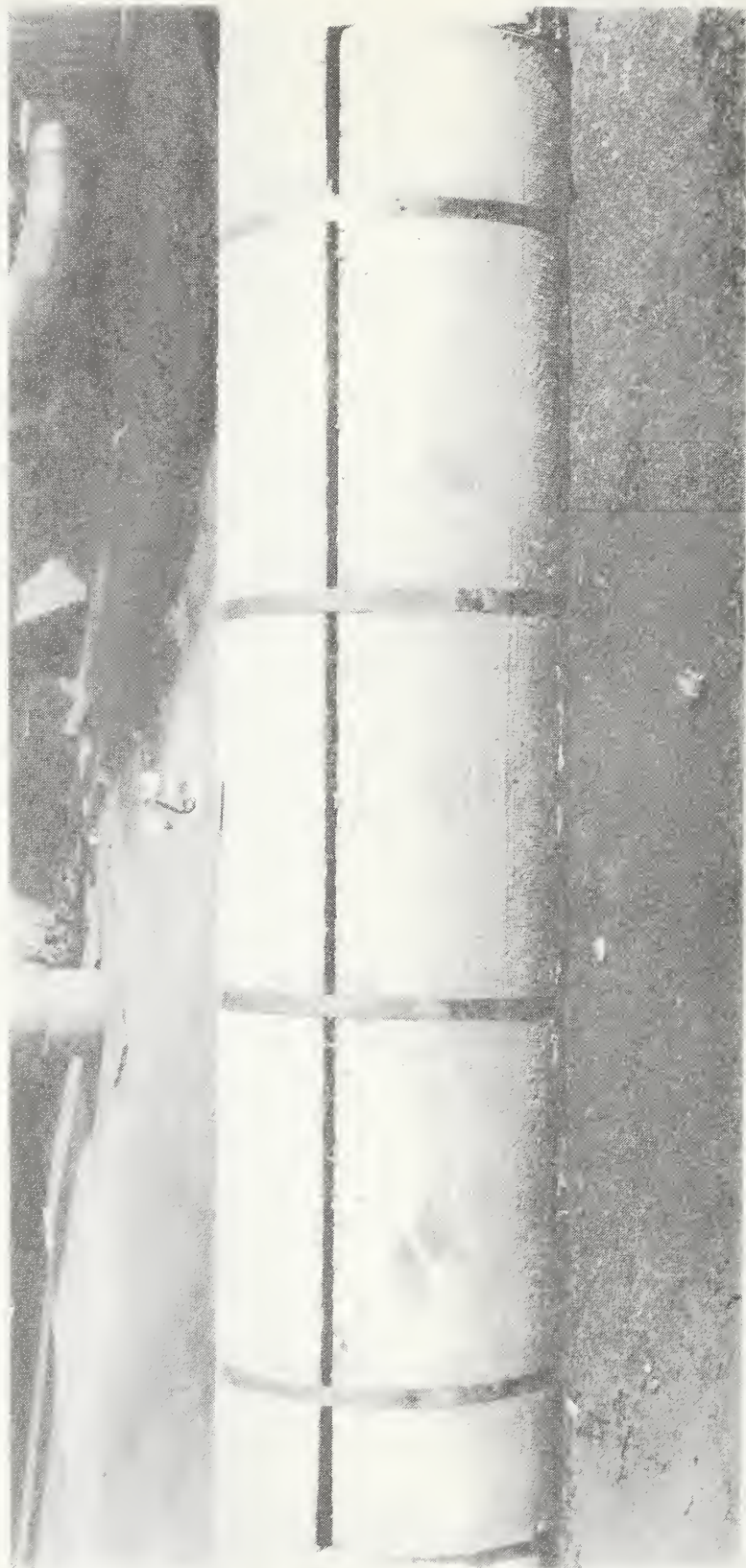

Figure 84. KAYLO-10 after 64 days of boiling.

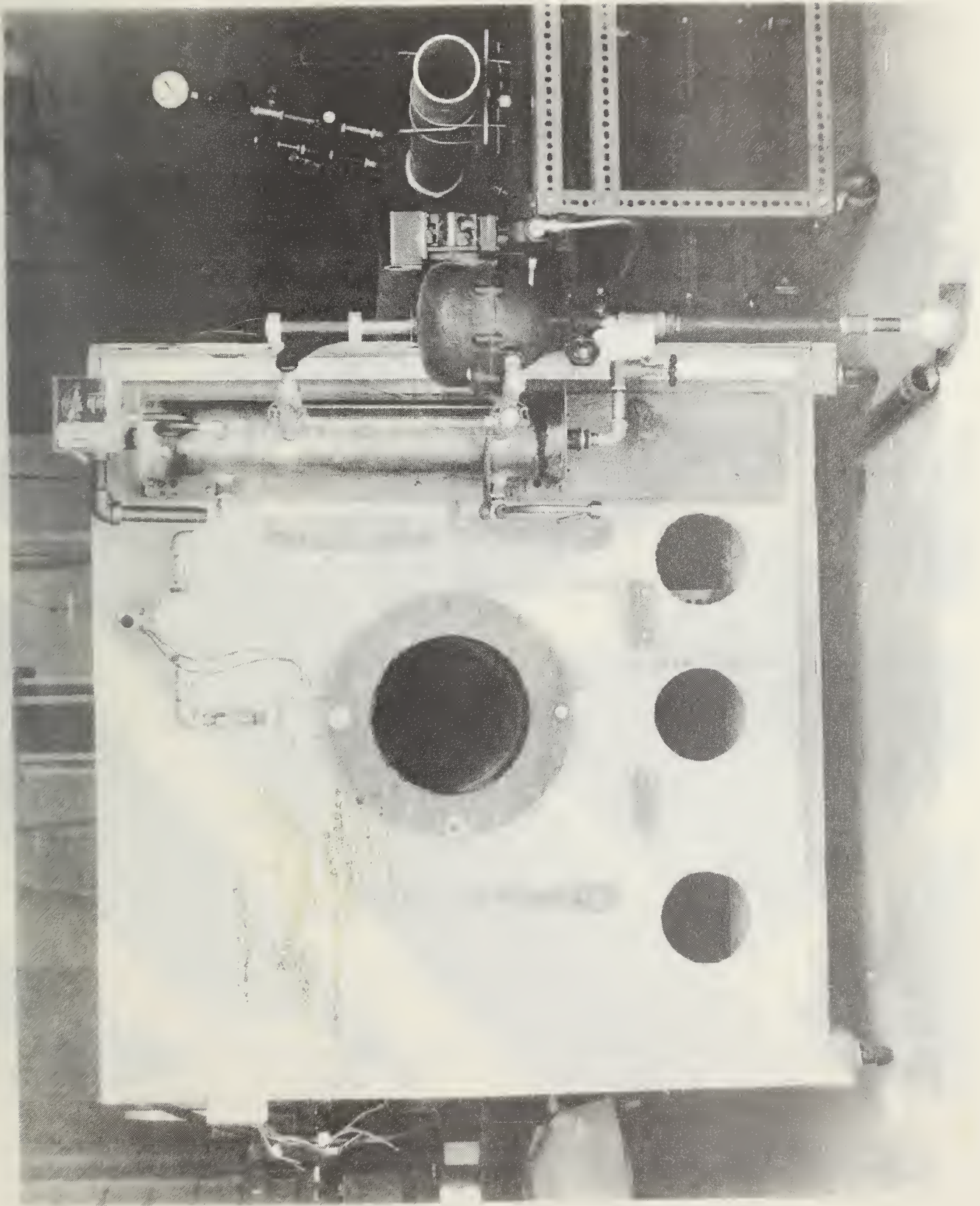

Figure 85. End view of plywood box used to house the conduit.

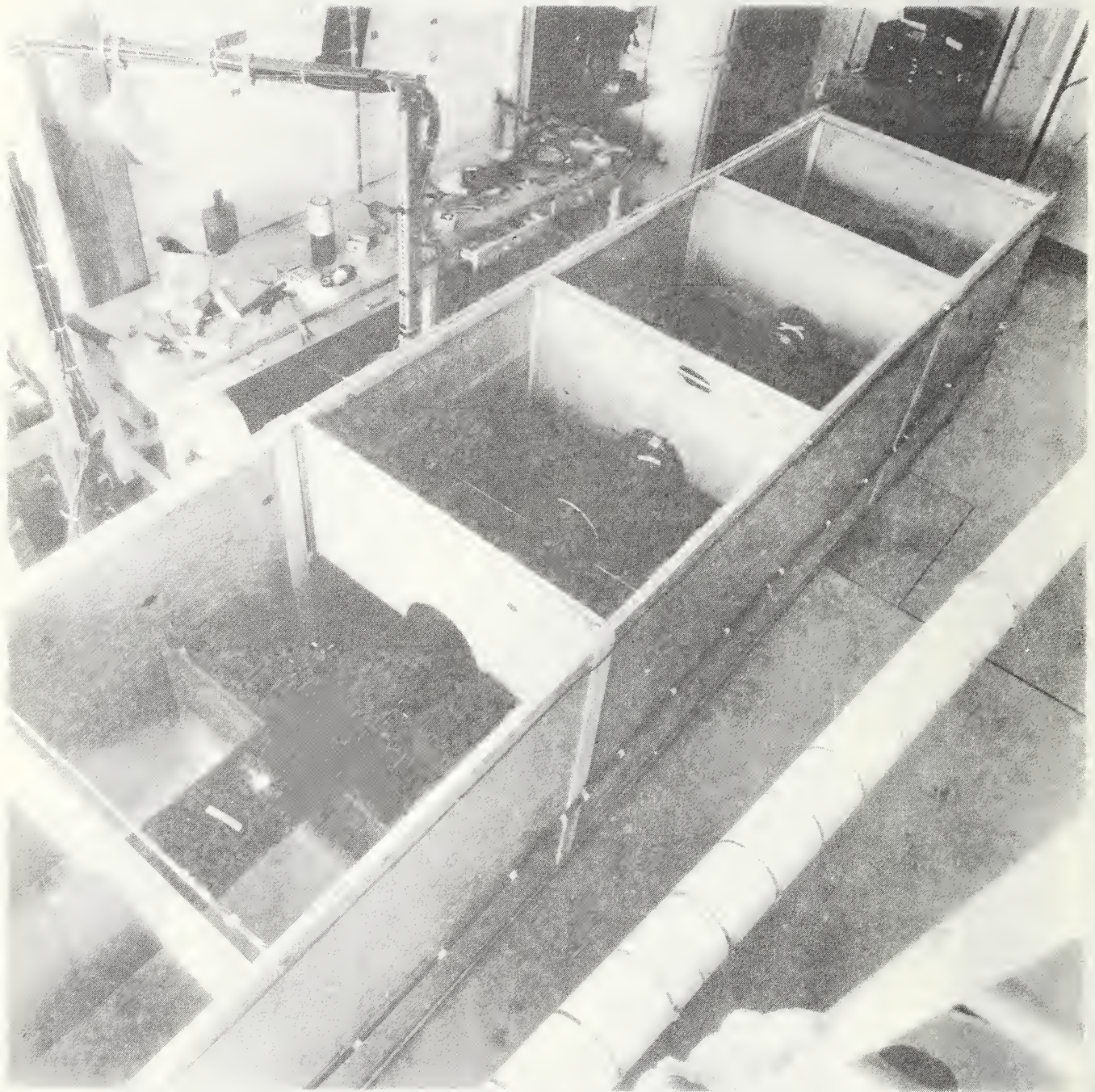

Figure 86. Inside of plywood box showing baffles to regulate air flow.

4. COMPARISON WITH CALCULATED PIPE HEAT TRANSFER FACTORS

While the previous section dealt with the experimental measurement of overall pipe heat transfer factor C , this section compares the measured data with the theoretical values determined by the standard pipe heat conduction calculation procedure.

Referring to figure 87, which depicts a cross section of the "air conduit system," the following notations and data are used to calculate the pipe heat transfer factor C :

- D = outside diameter of the carrier pipe, inch
- t_1 = pipe wall thickness, inch
- t_2 = thickness of calcium silicate insulation, inch
- t_3 = thickness of air space between the conduit and insulation, inch
- t_4 = thickness of conduit wall, inch
- T_1 = steam temperature, °F
- T_2 = temperature at the interface of carrier pipe and calcium silicate insulation, °F
- T_3 = temperature at the outside surface of the calcium silicate insulation, °F
- T_4 = temperature at the inside surface of the conduit wall, °F
- T_5 = temperature at the outside surface of the conduit wall, °F
- Q = overall pipe heat transfer, Btu/h ft
- C = overall pipe heat transfer factor, Btu/h ft, °F
- h = heat transfer coefficient at the conduit air space, Btu/hr ft² °F
- k_p = thermal conductivity of carrier pipe (test pipe) wall, Btu-in/h ft² °F
- k_I = thermal conductivity of calcium silicate insulation, Btu-in/h ft² °F
- k_c = thermal conductivity of conduit Btu-in/h.ft² °F

Using these notations, it is possible to write a steady-state heat conduction equation as follows:

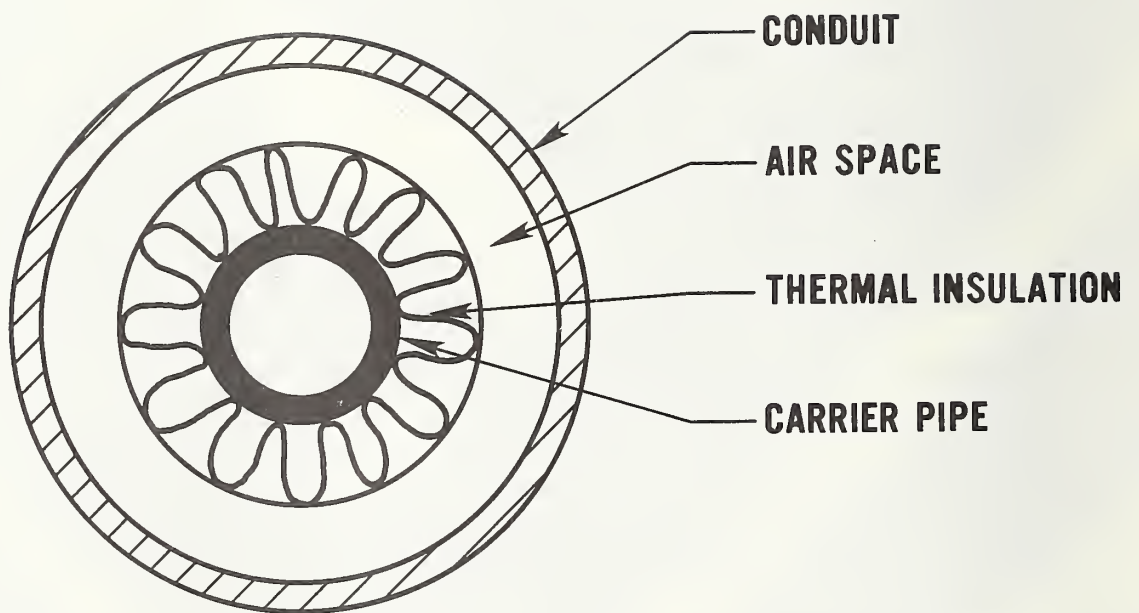

Figure 87. Cross-sectional view of the Tri-service "air conduit" underground heat distribution system.

$$\begin{aligned}
Q &= \frac{2\pi k_p (T_1 - T_2)}{12 \ln \left(\frac{D}{D-2t_1} \right)} \\
&= \frac{2\pi k_p (T_1 - T_2)}{12 \ln \left(\frac{D + Dt_2}{D} \right)} \\
&= \frac{\pi (D+2t_2) (h) (T_3 - T_4)}{12} \\
&= \frac{2\pi k_c (T_4 - T_5)}{12 \ln \left\{ \frac{D + 2t_2 + 2t_3 + 2t_4}{D + 2t_2 + 2t_3} \right\}} \\
&= C(T_1 - T_5)
\end{aligned}$$

Rearranging the above equations, the overall pipe heat temperature factor C is calculated by:

$$\begin{aligned}
\frac{1}{C} &= \frac{6}{\pi} \left\{ \frac{\ln \left(\frac{D}{D-2t_1} \right)}{k_p} + \frac{\ln \left(\frac{D+2t_2}{D} \right)}{k_I} + \frac{2}{h(D+2t_2)} \right. \\
&\quad \left. + \ln \left(\frac{D + 2t_2 + 2t_3 + 2t_4}{D + 2t_2 + 2t_3} \right) / k_c \right\}
\end{aligned}$$

For this particular test system, manufacturer's data^{*/} indicate that:

$$\begin{aligned}
D &= 4.5 \text{ in} \\
t_1 &= 0.25 \text{ in} \\
t_2 &= 2 \text{ in} \\
t_3 &= 1 \text{ in} \\
t_4 &= 0.25 \text{ in.}
\end{aligned}$$

Assuming the handbook values for thermal conductivities

$$k_p = 360 \text{ Btu-in/hr ft}^{2\circ\text{F}}$$

$$k_c = 360 \text{ Btu-in/hr ft}^{2\circ\text{F}}$$

$$h = 3 \text{ Btu/hr ft}^{2\circ\text{F}}^{**/}$$

^{*/} Ric-Wil publication of 1971 entitled "Prefabricated Insulation Piping System" p. 23.

^{**/} Approximate value based on unreported NBS test.

$$\frac{1}{C} = 1.9098 \left[\frac{0.117}{360} + \frac{0.636}{k_I} + \frac{0.232}{3} + \frac{0.02}{360} \right] = 0.000727 + \frac{1.2146}{k_I}$$

By using manufacturers' value of k_I , theoretical values of C were calculated and compared against measured values, as shown in table 2.

The measured heat transfer factor C is considerably higher than that anticipated from the standard heat conduction calculation, mainly for two reasons:

1. The conduit system has several pipe supports that act as thermal bridges, bypassing the insulation.
2. As shown in the conduit surface temperature distribution, as indicated in figures 34, 39, 43, 47, 53 and 58, there is a large amount of end heat loss.

These two factors, especially the end heat loss factor, are very critical when the test pipe is short -- so much so that they could overshadow the effect of the deterioration of pipe insulation due to the boiling test. Moreover, the 10 percent degradation criterion would favor the test system having higher total heat loss caused by the thermal bridge effect, because it would permit the acceptance of a larger heat loss increase through the insulated section of the test pipe. Although the estimation of the heat loss due to the thermal bridge and the end heat loss is very critical, the data shown in table 2 are so scattered that it is difficult to perform an error analysis.

Table 2. Comparison Between the Calculated and Measured Heat Transfer Factor C*

System Name	Manufacturer's data of $k_I@300^\circ\text{F}$	Calculated C	Measured C	
			before boiling	after boiling
Kaylo	0.46	0.379	0.506	0.632
Thermo 12	0.44	0.362	0.575	0.606
Pabco	0.45	0.370	0.601	0.625
Wesolite	0.44	0.362	0.635	0.667
Epitherm	0.39	0.321	0.472	0.490
Celotemp	0.52	0.424	0.617	0.694

* Calculated from the pipe to the exterior surface of the conduit.

5. REFERENCES

- [1] Seldon D. Cole and Paul R. Achenbach, "Effect of Boiling of the Insulation in Underground Heat Distribution Systems," NBS Report 7449, February, 1962.
- [2] TRI-Services, "Procedures for Establishing Acceptability of Underground Heat-Distribution Conduit Systems," Department of the Army, Corps of Engineers; Department of the Navy, Bureau of Yards and Docks; Department of the Air Force, Directorate of CE, July 1, 1964.

U.S. DEPT. OF COMM. BIBLIOGRAPHIC DATA SHEET (See instructions)	1. PUBLICATION OR REPORT NO. NBSIR 81-2324	2. Performing Organ. Report No.	3. Publication Date November 1981
4. TITLE AND SUBTITLE BOILING TESTS OF NON-ASBESTOS-BASED THERMAL INSULATION USED IN AIR-CONDUIT UNDERGROUND HEAT DISTRIBUTION SYSTEMS			
5. AUTHOR(S) Dr. T. Kusuda and W. M. Ellis			
6. PERFORMING ORGANIZATION (If joint or other than NBS, see instructions) NATIONAL BUREAU OF STANDARDS DEPARTMENT OF COMMERCE WASHINGTON, D.C. 20234		7. Contract/Grant No. 8. Type of Report & Period Covered	
9. SPONSORING ORGANIZATION NAME AND COMPLETE ADDRESS (Street, City, State, ZIP) <input type="checkbox"/> Tri-Services: Naval Facilities Engrg. Council, USN, Washington, DC 20390 Directorate of Civil Engrg., USAF, Washington, DC 20330 Office of Chief of Engrs., US Army, Washington, DC 20304			
10. SUPPLEMENTARY NOTES <input type="checkbox"/> Document describes a computer program; SF-185, FIPS Software Summary, is attached.			
11. ABSTRACT (A 200-word or less factual summary of most significant information. If document includes a significant bibliography or literature survey, mention it here) <p>Non-asbestos-based thermal insulation around steam carrier pipes is commonly used in the conduit underground heat distribution systems for many of the Tri-service installations. When the conduit fails, the insulation is expected to undergo severe boiling action due to the possible ingress of underground water. If the insulation is properly fabricated, it should withstand the prolonged boiling such that its thermal performance should be restored when the ground water is drained and the system dried.</p> <p>Several selected insulation systems were boiled in an open tank as well as in the conduit to test their ability for retaining the original insulation capability.</p> <p>Although the calcium silicate-based insulation system fell off the carrier pipe under the open tank boiling within 72 hours, most of the systems were able to withstand 96 hours of continuous boiling in the conduit. When drained and dried, these systems improved their thermal insulation performance to within 10 percent of the original value.</p>			
12. KEY WORDS (Six to twelve entries; alphabetical order; capitalize only proper names; and separate key words by semicolons) boiling test; conduit system; pipes; thermal insulation; underground heat distribution systems.			
13. AVAILABILITY <input type="checkbox"/> Unlimited <input checked="" type="checkbox"/> For Official Distribution. Do Not Release to NTIS <input type="checkbox"/> Order From Superintendent of Documents, U.S. Government Printing Office, Washington, D.C. 20402. <input type="checkbox"/> Order From National Technical Information Service (NTIS), Springfield, VA. 22161		14. NO. OF PRINTED PAGES 15. Price	



