

NBSIR 78-870

**EVALUATION OF LOW-LOSS/LOW-REFLECTION
TWO-PORT DEVICES OR ADAPTERS BY
AUTOMATED MEASUREMENT TECHNIQUES**

Ramon L. Jesch

Electromagnetics Division
Institute for Basic Standards
National Bureau of Standards
Boulder, Colorado 80302

December 1977

NBSIR 78-870

**EVALUATION OF LOW-LOSS/LOW-REFLECTION
TWO-PORT DEVICES OR ADAPTERS BY
AUTOMATED MEASUREMENT TECHNIQUES**

Ramon L. Jesch

Electromagnetics Division
Institute for Basic Standards
National Bureau of Standards
Boulder, Colorado 80302

December 1977



U.S. DEPARTMENT OF COMMERCE, Juanita M. Kreps, Secretary

Sidney Harman, Under Secretary

Jordan J. Baruch, Assistant Secretary for Science and Technology

NATIONAL BUREAU OF STANDARDS, Ernest Ambler, Acting Director

CONTENTS

	<u>Page</u>
ABSTRACT-----	i
1. INTRODUCTION-----	1
2. INSTRUMENTATION-----	2
3. MEASUREMENT METHOD-----	3
4. VERIFICATION OF MEASURED SCATTERING PARAMETERS-----	4
5. EXPERIMENTAL RESULTS OF DATA BASE-----	7
6. CONCLUSIONS-----	9
7. REFERENCES-----	11

EVALUATION OF LOW-LOSS/LOW-REFLECTION TWO-PORT DEVICES OR ADAPTERS
BY AUTOMATED MEASUREMENT TECHNIQUES

R. L. Jesch

With the addition of a hardware modification on the National Bureau of Standards (NBS) Automatic Network Analyzer (ANA) and the incorporation of diagnostic procedures in the adapter software program, accurate values of adapter scattering parameters can now be obtained up to 12.4 GHz. Measurement results that verify the adapter scattering parameters are given along with a data base that was accumulated at 8 to 10 GHz for three 7mm to Type N female adapters from different manufacturers. Statistical methods were applied to this measurement data and an inference made about this family group of adapters.

Key words: Adapter; data base; maximum efficiency; power meters; reflection coefficient; scattering parameters; test set.

1. INTRODUCTION

In response to a request from the Department of Defense Calibration Coordination Group (DoD/CCG) R. F. Measurements Working Group, the National Bureau of Standards, in 1973, undertook a project to reduce to practice a proposed theoretical method [1] for characterizing adapters by automated measurement techniques. The work performed during the period May 1973 to September 1973 was reported in NBSIR 73-350, "Adapter Evaluation by Automated Measurements" [2].

That report described the basic theory, equations, instrumentation, and procedure required to evaluate adapters by automated techniques. Further, it showed that in automating the manual measurement technique for adapter efficiency that the entire set of scattering parameters required for adapter evaluation could be obtained with little further effort.

The present report, which is the final report on CCG project 72-72B, covers the work performed from July 1974 to February 1976. It reviews the instrumentation and measurement method that is required to obtain the adapter scattering parameters. One goal of the work to be reported here was to verify measured scattering parameters with known standards and evaluate the characteristics of a selection of adapters, e.g., 14mm and 7mm to type N and 7mm to WR-90. Another goal was to start to accumulate a data base for 7mm to type N female adapters at 8 to 12.4 GHz. The final goal of this project, to develop an algorithm that showed how to correct the measurements taken where the adapter was connected to a device, such as bolometer, attenuator, etc., was never completed because of reduced funding for the adapter evaluation project for FY 76.

2. INSTRUMENTATION

Existing, commercially available automated measurement systems are generally designed around the reflectometer concept and include a complex ratio detector as shown in figure 1.

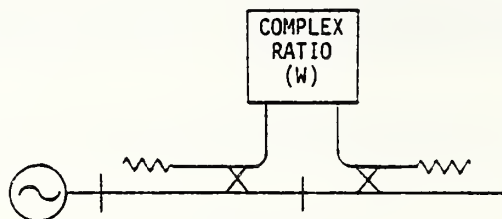

Figure 1. Basic test set.

The performance of the complex ratio detector generally falls substantially short of what is required to achieve state-of-the-art accuracy on low-loss/low-reflection two-port devices or adapters. To achieve these accuracy goals, it was necessary for the National Bureau of Standards to replace the test set of figure 1 by that shown in figure 2. (The addition of the two power meters, of 0.1% accuracy, is the key feature which permits a measurement of the absolute levels at the sidearms in addition to the response of the existing complex

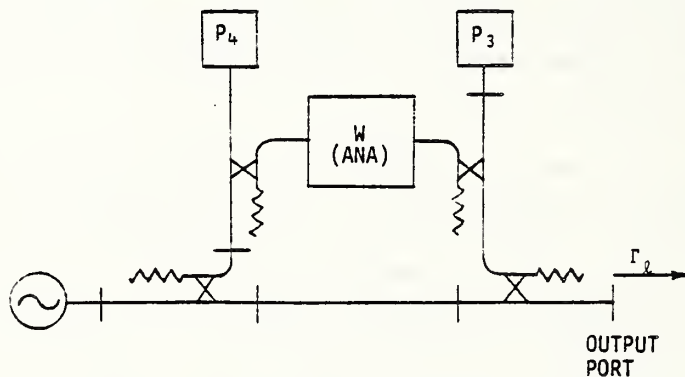

Figure 2. Test set for adapter evaluation.

ratio detector which is retained primarily for phase information.) This hardware modification and a complete description of the mathematical theory and its reduction to measurement practice were described by Engen [3].

Although the power meters P_3 , P_4 provide an absolute level indication, it is only their ratio which is of interest in adapter evaluation. In short, the power meters permit an order of magnitude, or more, improvement in the accuracy with which the magnitude of the

complex ratio is measured [3]. Although the dynamic range over which this improvement is realized is only 20 dB or so, this is more than adequate for the immediate application.

3. MEASUREMENT METHOD

The well-known relationship between the complex ratio, w , and the reflection coefficient, Γ_λ , at the output port is given by,

$$w = \frac{a\Gamma_\lambda + b}{c\Gamma_\lambda + 1} \quad (1)$$

where a , b , c are complex constants which characterize the measurement system. The relationship between P_3 , P_4 , and w may be written,

$$|w|^2 = K \frac{P_3}{P_4} \quad (2)$$

where K is a real constant. The evaluation of a , b , c is generally referred to as a calibration of the system and is basic to automated measurements. The parameter, K , can be easily evaluated by comparing the values $|w|^2$ and P_3/P_4 for several values of w and averaging. Provided that Γ_λ is such that P_3 and P_4 are within the dynamic range of power meter operation, $|w|^2$ is determined from (2), and the only role of the complex ratio detector is to provide the argument. As $|\Gamma_\lambda|$ becomes small, however, P_3 also becomes small, and it is necessary to obtain both magnitude and phase from the complex ratio detector.

The calibration of the measurement system is conducted at the output port (see fig. 3)

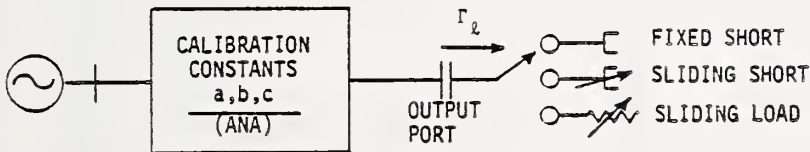

Figure 3. System calibration procedure.

using a fixed short circuit, a sliding short circuit, and a sliding low-reflection load to determine the calibration constants a , b , c . The adapter calibration is performed in the same manner as before with the adapter connected to the measurement system and the calibration conducted at the output port (see fig. 4) of the adapter using a fixed short, sliding short and load in the type of transmission line or waveguide which terminate the adapter to be measured. The new calibration constants a' , b' , c' include both the measurement system plus the adapter.

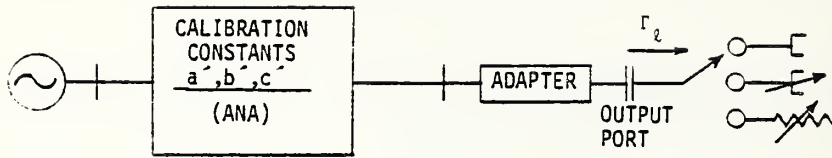

Figure 4. Adapter calibration procedure.

The design of the hardware and software for the adapter measurement system is arranged to measure the scattering parameters of any adapter or two-port device regardless of input and output connections. Accordingly, in order to measure a coax-to-waveguide adapter, a coaxial fixed short, sliding short and load are used for the initial system calibration while a waveguide fixed short, sliding short and load are used for the adapter calibration. The system also provides for measuring S_{11} only, the magnitude and phase of reflection coefficient, for a termination. This type of measurement is performed immediately after the system calibration.

The scattering parameters for the adapter are obtained by mathematically extracting the calibration constants of the measurement system from the calibration constants of the adapter calibration and are related by equations (3), (4), and (5).

$$S_{11} = \frac{b' - b}{a - b'c} \quad (3)$$

$$S_{22} = \frac{a'c - ac'}{a - b'c} \quad (4)$$

and

$$S_{12}^2 = \frac{a' - bc'}{a - b'c} + S_{11}S_{12}. \quad (5)$$

The assumption is made that $S_{12} = S_{21}$. The software is designed to lead an operator through the measurement procedure without his having a knowledge of the basic theory.

4. VERIFICATION OF MEASURED SCATTERING PARAMETERS

The original adapter software that was developed for the initial adapter evaluation project, in 1973, lacked certain important features making it extremely difficult to properly analyze and to systematically eliminate certain calibration and measurement errors. This deficiency was overcome by developing and incorporating diagnostic procedures for

measuring and analyzing the adapter measurement system for power drift, phase error, and detector error. Also, the capability of this new program to correct the detector error for both magnitude and phase ultimately increased the measurement accuracy of S_{11} and S_{22} .

A number of measurements were taken to examine and verify the scattering parameters with known standards. Test results are given in Tables 1, 2, and 3 that show the effects of adding the diagnostics. These results show a significant improvement in repeatability between the same efficiency measurements and the other scattering parameters, i.e., S_{11} and S_{22} . Briefly, the design of the hardware and software for the adapter measurement system is arranged to determine the scattering parameters of any one-port device and of any adapter or relatively low-loss two-port device by measuring the magnitude and phase of the input reflection coefficient with various terminations on the output as described in Section 3 on the measurement method.

Shown below in Table 1 are S_{11} measurement results of an S-band (WR-284) flat short circuit and a 14 mm flat short circuit taken between 2.4 and 4 GHz. These results demonstrate the high degree of measurement accuracy that is possible with the power meters that are used in the adapter measurement system for measuring complex ratios. The estimated reflection coefficient value of both short circuits is $0.997 \angle -180^\circ$. This value was extrapolated from test results that compared open-circuit measurements with quarter-wavelength short circuit primary reference standards that were evaluated at fixed frequencies.

TABLE 1

<u>S-Band Flat Short Circuit</u>		<u>14 mm Flat Short Circuit</u>	
<u>FREQ</u>	<u>Mag--S11--ANG</u>	<u>FREQ</u>	<u>MAG--S11--ANG</u>
2400.	.99703 - 179.89	2400.	.99730 - 179.94
2500.	.99710 - 179.93	2500.	.99732 - 179.93
2600.	.99702 - 179.99	2600.	.99732 - 179.95
2700.	.99710 - 179.93	2700.	.99738 - 179.90
2800.	.99712 - 180.00	2800.	.99727 - 179.90
2900.	.99707 - 179.92	2900.	.99733 + 179.99
3000.	.99703 - 179.99	3000.	.99728 - 179.93
3100.	.99688 - 179.94	3100.	.99738 + 179.99
3200.	.99687 - 179.95	3200.	.99728 - 179.93
3300.	.99706 - 179.99	3300.	.99726 - 179.97
3400.	.99701 - 179.92	3400.	.99724 - 179.90
3500.	.99681 - 179.91	3500.	.99724 - 179.97
3600.	.99690 - 180.00	3600.	.99738 - 179.92
3700.	.99685 - 179.93	3700.	.99735 - 179.96
3800.	.99703 - 179.92	3800.	.99742 - 179.93
3900.	.99652 - 179.98	3900.	.99747 - 179.91
4000.	.99664 - 179.92	4000.	.99762 - 179.93

In order to obtain a good indication of the validity of the calibration procedure and the precision to which the impedance standards can be connected and disconnected, a special test was designed. The same procedure for measuring adapters is followed for this special test but without the adapter being inserted. This special test consists of measuring a nonexistent adapter which the computer program print-out refers to as a "phantom two-port"

and gives the degree to which $|S_{11}| = 0$, $|S_{22}| = 0$, and Max. Eff. = 1. Table 2 shows the test results that were obtained for S_{11} , S_{22} and Max Eff. between 4.5 and 7.5 GHz using 14 mm precision components. Similar results at these and other frequencies are rarely achieved the first time the adapter measurement system is calibrated which indicates a poor connection or insufficient system warm-up time.

TABLE 2
PHANTOM TWO-PORT

<u>FREQ</u>	<u>MAG--S11--ANG</u>		<u>MAG--S22--ANG</u>		<u>MAX. EFF.</u>
4500.	.00011	144.04	.00075	249.13	1.00000
5500.	.00053	-78.19	.00092	126.48	1.00000
6500.	.00083	176.62	.00089	-36.46	.99999
7500.	.00025	-76.34	.00137	-40.22	1.00000

A reciprocal but nonsymmetric test device to simulate an adapter was constructed using a WR-90 waveguide tuner and a 20 dB variable attenuator set for a minimal 3 dB value. The test device was measured at three X-band frequencies (9.2, 9.3, and 9.4 GHz) to determine:

- a. The correctness of the calculation procedure, and
- b. the accuracy of the measurement method for obtaining the adapter parameters, i.e., S_{11} , S_{22} , and maximum efficiency.

The parameters of the test device were measured in one direction, then ports 1 and 2 were reversed and the parameters remeasured under the same conditions. As a check on the accuracy, $|S_{11}|$ forward should equal $|S_{22}|$ reverse, $|S_{22}|$ forward should equal $|S_{11}|$ reverse, and Max. Eff. forward should equal Max. Eff. reverse. Results shown in Table 3 indicate measurement agreement in S_{11} and S_{22} that varies within 0.0003 to 0.0019 in magnitude and 0.00006 to 0.0012 in Max. Eff. The angles, ϕ_{11} and ϕ_{22} , become indeterminate as the magnitude gets smaller.

TABLE 3

Forward (Tuner + Attenuator)

<u>FREQ.</u>	<u>MAG--S11--ANG</u>		<u>MAG--S22--ANG</u>		<u>MAX. EFF.</u>
9200.	.24320	-26.58	.08274	83.72	.45770
9300.	.22908	-55.60	.07647	51.12	.45898
9400.	.20869	-81.45	.06798	12.96	.45838

Reverse (Attenuator + Tuner)

9200.	.08428	82.67	.24510	-25.83	.45892
9300.	.07687	49.68	.22755	-55.32	.45814
9400.	.06839	19.08	.21024	-82.98	.45932

5. EXPERIMENTAL RESULTS OF DATA BASE

An adequate data base of various kinds of adapters must be accumulated, analyzed, and applied to important measurement situations. These data enable one to derive limit-of-error data on measurements of devices made through and interconnected by means of these adapters.

We begin to accumulate a data base on 7 mm to type N female adapters at 8 to 12.4 GHz using adapters from different manufacturers. This adapter type was requested by the project sponsor. The characteristics of a selection of other adapters, e.g., 14 mm and 7 mm to type N, 7 mm to WR-90, were also investigated, but only at a few spot frequencies.

Test results for three 7 mm to type N female adapters from different manufacturers are given in Tables 4, 5, and 6. The test results show the mean and standard deviations (sd) for the magnitudes of S_{11} , S_{22} , and the maximum efficiency that were determined from measurement runs taken at 8 to 10 GHz. The adapters were measured in one direction only. The column for S_{11} represents the results for the 7 mm connector used as the input side while the column for S_{22} represents the results for the type N female connector used as the output side. A plot of the magnitudes of S_{11} and S_{22} , taken from Tables 4, 5, and 6, is given in figure 5. Shown below in Table 4 are the mean and sd for the parameters that were determined from six measurement runs. The sd for S_{11} varied between a low of 0.00071 and a high of 0.00168. The sd for S_{22} varied between a low of 0.00255 and a high of 0.00525. The sd for the maximum efficiency varied between a low of 0.00188 and a high of 0.00485.

TABLE 4

Adapter A

Freq. GHz	Mag. S ₁₁ (7 mm side)		Mag. S ₂₂ (Type N side)		Max. Efficiency	
	Mean	sd	Mean	sd	Mean	sd
8.0	.00221	.00071	.00743	.00525	.99390	.00485
8.2	.00125	.00077	.00670	.00255	.98816	.00188
8.4	.00176	.00128	.00309	.00322	.98819	.00254
8.6	.00250	.00151	.00301	.00286	.98851	.00325
8.8	.00338	.00168	.00284	.00276	.98812	.00276
9.0	.00412	.00158	.00412	.00302	.98933	.00322
9.2	.00492	.00156	.00358	.00319	.99008	.00390
9.4	.00547	.00143	.00481	.00294	.98914	.00376
9.6	.00593	.00143	.00584	.00328	.99130	.00356
9.8	.00612	.00139	.00382	.00331	.99204	.00298
10.0	.00594	.00102	.00299	.00269	.99478	.00421

Shown in Table 5 are the mean and sd for the parameters that were determined from three measurement runs. The sd for S₁₁ varied between a low of 0.00076 and a high of 0.00124. The sd for S₂₂ varied between a low of 0.00039 and a high of 0.00162. The sd for the maximum efficiency varied between a low of 0.00047 and a high of 0.00834.

TABLE 5

Adapter B

Freq. GHz	Mag. S ₁₁ (7 mm side)		Mag. S ₂₂ (Type N side)		Max. Efficiency	
	Mean	sd	Mean	sd	Mean	sd
8.0	.03175	.00076	.03063	.00091	.98777	.00285
8.2	.03198	.00066	.02960	.00162	.98397	.00391
8.4	.03310	.00062	.03051	.00086	.98691	.00131
8.6	.03455	.00084	.03055	.00119	.99043	.00834
8.8	.03400	.00076	.03062	.00141	.98749	.00270
9.0	.03390	.00111	.02941	.00079	.98593	.00122
9.2	.03354	.00112	.02748	.00106	.98608	.00047
9.4	.03273	.00095	.02422	.00111	.99031	.00114
9.6	.03139	.00123	.02638	.00011	.98908	.00047
9.8	.03024	.00124	.02516	.00079	.98885	.00142
10.0	.02794	.00043	.02362	.00039	.99186	.00295

Shown below in Table 6 are the mean and sd for the parameters that were determined from three measurement runs. The sd for S₁₁ varied between a low of 0.00674 and a high of 0.01338. The sd of S₂₂ varied between a low of 0.00321 and a high of 0.01196. The sd of the maximum efficiency varied between a low of 0.00222 and a high of 0.00961.

TABLE 6
Adapter C

Freq. GHz	Mag. S ₁₁ (7 mm side)		Mag. S ₂₂ (Type N side)		Max. Efficiency	
	Mean	sd	Mean	sd	Mean	sd
8.0	.01594	.00674	.01901	.00360	.99114	.00767
8.2	.01606	.00721	.01785	.00321	.98340	.00222
8.4	.01611	.00814	.01430	.00757	.98740	.00282
8.6	.01593	.01044	.01560	.00456	.99171	.00726
8.8	.01441	.01071	.01478	.00996	.98909	.00233
9.0	.01289	.01200	.01280	.01196	.98640	.00428
9.2	.01165	.01309	.01334	.00927	.98683	.00414
9.4	.01064	.01338	.01297	.00912	.98788	.00538
9.6	.01074	.01240	.01632	.00645	.99186	.00794
9.8	.01097	.01174	.01518	.00487	.99071	.00935
10.0	.01059	.01028	.01602	.00507	.99107	.00961

Some of the measurement runs for all three adapters were taken close in time--within a two-day period, while the other runs were taken about three weeks later. Some of the measurement runs used the same ANA calibration while the others were each preceded by a separate ANA calibration. The main point is that despite this variation in method and time span, the results are remarkably consistent. The magnitudes of S₁₁ and S₂₂ for the adapter from Table I are about an order of magnitude better than for the other two adapters in Tables II and III. The maximum efficiency for all three adapters is about the same. There is of course a difference in evaluating the statistical properties of a single adapter and in evaluating the characteristics of a selection of adapters from a family group. An adequate data base of adapters from a family group must be accumulated before making inferences from the measurement data about that family group by application of statistical methods.

6. CONCLUSIONS

A technique has been presented that gives a complete description of an adapter or other low-loss two-port device in terms of its scattering parameters. Test results show the accuracy of the measurement method for obtaining these scattering parameters. Previously, accurate values of the adapter scattering parameters were not attainable on existing automated measurement systems.

A partial data base was accumulated and tabulated on 7 mm to type N female adapters. The reduced level of funding for FY 76 left this particular goal incomplete, in addition to leaving one of the most important aspects of this project unfinished; Resolve the question of how the scattering parameters of an adapter should be used when the adapter is connected to a device, such as a bolometer, attenuator, etc. This is of importance in each of the two cases: First, when it is desired to measure the device properties by means of a measuring system (ANA, etc.) whose terminal connectors differ from those of the devices. Second, when

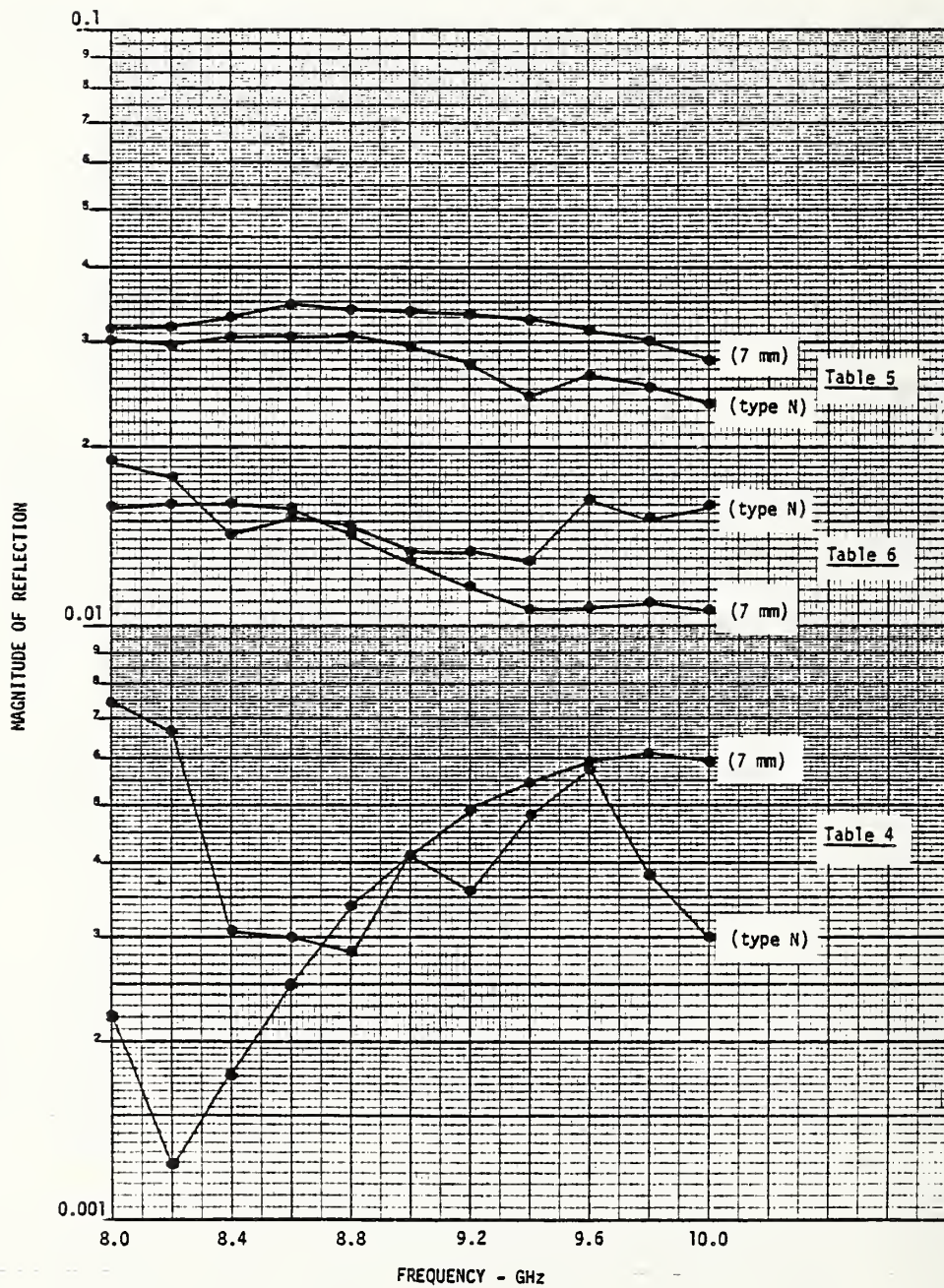

Figure 5. Plot of the magnitudes of S_{11} and S_{22} .

it is desired to use that device in conjunction with a system whose terminal connectors differ from those of the device.

7. REFERENCES

- [1] Engen, G. F., An extension to the sliding short method of connector and adapter evaluation, J. Res. Nat. Bur. Stand., (U.S.) 75C, (Eng. & Instr.), Nos. 3 & 4, 177-183, (July-December 1971).
- [2] Jesch, R. L., Engen, G. F., Weidman, M. P., Adapter evaluation by automated measurement, NBSIR 73-350, 14 pages (December 1973).
- [3] Engen, G. F., Calibration technique for automated network analyzers with application adapter evaluation, IEEE Trans. Microwave Theory Tech., MTT-22, No. 12, 1255-1260, (December 1974).

U.S. DEPT. OF COMM. BIBLIOGRAPHIC DATA SHEET	1. PUBLICATION OR REPORT NO. NBSIR 78-870	2. Gov't Accession No.	3. Recipient's Accession No.
4. TITLE AND SUBTITLE Evaluation of Low-Loss/Low-Reflection Two-Port Devices Or Adapters by Automated Measurement Techniques		5. Publication Date December 1977	6. Performing Organization Code
7. AUTHOR(S) Ramon L. Jesch		8. Performing Organ. Report No.	
9. PERFORMING ORGANIZATION NAME AND ADDRESS NATIONAL BUREAU OF STANDARDS DEPARTMENT OF COMMERCE WASHINGTON, D.C. 20234		10. Project/Task/Work Unit No. 2761462	11. Contract/Grant No. CCG 72-72B
12. Sponsoring Organization Name and Complete Address (Street, City, State, ZIP) Department of Defense Calibration Coordination Group Newark, Ohio 43055		13. Type of Report & Period Covered Final July 1974 to February 1976	14. Sponsoring Agency Code
15. SUPPLEMENTARY NOTES			
<p>16. ABSTRACT (A 200-word or less factual summary of most significant information. If document includes a significant bibliography or literature survey, mention it here.)</p> <p>With the addition of a hardware modification on the National Bureau of Standards (NBS) Automatic Network Analyzer (ANA) and the incorporation of diagnostic procedures in the adapter software program, accurate values of adapter scattering parameters can now be obtained up to 12.4 GHz. Measurement results that verify the adapter scattering parameters are given along with a data base that was accumulated at 8 to 10 GHz for three 7mm to Type N female adapters from different manufacturers. Statistical methods were applied to this measurement data and an inference made about this family group of adapters.</p>			
<p>17. KEY WORDS (six to twelve entries; alphabetical order; capitalize only the first letter of the first key word unless a proper name; separated by semicolons)</p> <p>Adapter; data base; maximum efficiency; power meters; reflection coefficient; scattering parameters; test set.</p>			
<p>18. AVAILABILITY <input type="checkbox"/> Unlimited</p> <p><input checked="" type="checkbox"/> For Official Distribution. Do Not Release to NTIS</p> <p><input type="checkbox"/> Order From Sup. of Doc., U.S. Government Printing Office Washington, D.C. 20402, SD Cat. No. C13</p> <p><input type="checkbox"/> Order From National Technical Information Service (NTIS) Springfield, Virginia 22151</p>		<p>19. SECURITY CLASS (THIS REPORT)</p> <p>UNCLASSIFIED</p>	<p>21. NO. OF PAGES</p> <p>16</p>
		<p>20. SECURITY CLASS (THIS PAGE)</p> <p>UNCLASSIFIED</p>	<p>22. Price</p> <p>\$4.00</p>