

Reference

NBS  
Publi-  
cations



~~A11101 726803~~

A11104 237586

**NBSIR 78-1502**

# **Smoke Measurements in Large and Small Scale Fire Testing**

---

Richard W. Bukowski

Center for Fire Research  
National Engineering Laboratory  
National Bureau of Standards  
Washington, D.C. 20234

October 1978

Final Report

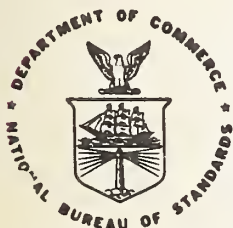

**S. DEPARTMENT OF COMMERCE**

**NATIONAL BUREAU OF STANDARDS**

QC

100

U56

78-1502



APR 17 1979

NOT ACC. REC.

Q2005

1056

10.18.80

NBSIR 78-1502

**SMOKE MEASUREMENTS IN LARGE AND SMALL SCALE FIRE TESTING**

Richard W. Bukowski

Center for Fire Research  
National Engineering Laboratory  
National Bureau of Standards  
Washington, D.C. 20234

October 1978

Final Report

NBS Interagency Report NBSIR 78-1502

**U.S. DEPARTMENT OF COMMERCE, Juanita M. Kreps, Secretary**

**Dr. Sidney Harman, Under Secretary**

**Jordan J. Baruch, Assistant Secretary for Science and Technology**

**NATIONAL BUREAU OF STANDARDS, Ernest Ambler, Director**



## CONTENTS

	Page
LIST OF FIGURES . . . . .	iv
Abstract . . . . .	1
1. THE NEED FOR COMPARABLE MEASUREMENTS OF SMOKE . . . . .	1
2. THEORY OF OPTICAL MEASUREMENTS . . . . .	3
3. CURRENT PHOTOMETER DESIGNS . . . . .	5
4. PROTOTYPE PHOTOMETER: DESIGN DESCRIPTION AND DISCUSSION . . . . .	8
5. THE NEED FOR A REFERENCE IONIZATION CHAMBER . . . . .	12
6. FUTURE NEEDS . . . . .	14
7. REFERENCES . . . . .	16

## LIST OF FIGURES

		Page
Figure 1.	NBS extinction beam photometer and six-channel control . . . . .	18
Figure 2.	Light scattering and extinction by a particle . . . . .	19
Figure 3.	Theory of optical smoke measurements . . . . .	20
Figure 4.	Typical photometer design . . . . .	21
Figure 5.	Variation of optical density with wavelength for typical black and white smokes . . . . .	22
Figure 6.	NBS extinction beam photometer light source . . . . .	23
Figure 7.	NBS extinction beam photometer receiver . . . . .	24
Figure 8.	Typical schematic - two-channel amplifier . . . . .	25
Figure 9.	Circuit for converting percent transmittance to optical density or optical density per unit length . . . . .	26
Figure 10.	Test results - photometer calibration with neutral density filters . . . . .	27
Figure 11.	Relative sensitivity of various detection principles for constant mass concentration . . . . .	28
Figure 12.	Reference ionization chamber based on a commercial detector . . . . .	29
Figure 13.	Hosemann reference ionization chamber . . . . .	30
Figure 14.	The separated ionization chamber . . . . .	31
Figure 15.	The Cerberus measuring ionization chamber . . . . .	32
Figure 16.	Mie scattering by polydisperse spheres compared with diffraction, refraction, and reflection as a function of scattering angle . . . . .	33
Figure 17.	The Sinnott-Gravatt multiple scattering instrument . . . . .	34
Figure 18.	Japanese computer fire tests-success percentages . . . . .	35

# SMOKE MEASUREMENTS IN LARGE AND SMALL SCALE FIRE TESTING

Richard W. Bukowski

## Abstract

The extinction beam photometer is the most widely used instrument for taking smoke measurements in fire testing. Most existing designs were found to be inaccurate and unreliable for measurements where smoke detection performance is evaluated due to the low levels of smoke present at activation. Accordingly, a new extinction beam photometer design was developed which will provide the stability and accuracy necessary for these measurements. The paper describes the new design and proposes its adoption as an industry standard.

The paper also discusses the need for a reference ionization chamber instrument and a reference measurement which relates to gas sensing fire detectors.

Key words: Fire testing; ionization chamber; light extinction; light scattering; Mie scattering; Rayleigh scattering; smoke measurements.

## 1. THE NEED FOR COMPARABLE MEASUREMENTS OF SMOKE

As demonstrated by the old saying "where there's smoke there's fire," the interrelationship between smoke and fire has always been recognized. As pertains to safety to life, smoke is also recognized as perhaps the most important by-product of a fire; since reduction of visibility and associated panic is the most common and earliest occurring factor which prevents people involved in a fire from escaping the fire area. Of course, eye irritation from smoke is an important factor

in visibility which cannot be measured by these instruments. Thus, the relationship between these measurements and human visibility are only valid for non-irritating smokes, or where a self-contained breathing apparatus with full face mask is used.

The importance of smoke measurements in fire testing has greatly increased since the development of the smoke detector as a fire protection device. The phenomenal increase in the use of smoke detectors over the last few years, especially in residential applications, has resulted in a large increase in the number of people making smoke measurements in research, product development, and product testing and approval.

The level of sophistication of the smoke aerosol measurements depends on the amount of detail one needs in terms of the smoke properties. If, for example, one were interested in the size distributions of a variety of smokes, one might use an electrical aerosol analyzer, a cascade impactor, an optical particle counter, and/or a condensation nuclei counter. These are sophisticated, expensive instruments requiring some care in operation as well as expertise in reducing the data. Such instruments are not the concern of this paper; instead, the interest is in inexpensive, reliable smoke measurements that provide some measure of the smoke hazard. The primary measurement technique described here is the measurement of light attenuation.

Since, on the surface, the measurement of smoke by the attenuation of light appears to be rather straightforward, most people making these measurements build their own photometers. There are as many different designs as there are people building them, and often these designs make only minimal attempts to take into account the well-defined theory of light attenuation by aerosols.

Since fire itself is an extremely complex physical and chemical phenomenon, a vast amount of data are necessary to attempt to understand the burning process. Of necessity, this data comes from many different sources, so measurements of the various parameters of fire must be



comparable among these sources. The only way to achieve this comparability is to minimize the number of variables in instrument design which can affect the measurements. For this reason, NBS has developed a reference extinction beam photometer for smoke measurements. This photometer and a six-channel amplifier are shown in figure 1.

## 2. THEORY OF OPTICAL MEASUREMENTS

The theories defining the attenuation of a beam of light by suspended aerosol particulates have been fairly well defined since the late 19th and early 20th centuries. Theories by such familiar names as Lambert-Beer, Mie, and Rayleigh clearly define the extinction phenomena. The following represents a simplified discussion of these theories.

The extinction phenomenon is simply the removal or attenuation of light in a transmitted beam by a suspension of particles. As shown in figure 2, a suspension of particles will always remove light from an illuminating beam by scattering, and also by absorption if the particles are made of absorbing material. The amount of light removed from the illuminating beam is a function of the optical characteristics of the particle, the number of particles, the size of the particles, and the wavelength of the light. The extinction beam photometer measures only the reduction in transmitted light, independent of whether it is reduced by absorption and/or scattering. For dark, large spherical particle smokes where absorption predominates, the Lambert-Beer law governing the extinction phenomenon can be expressed by the formula: [1]<sup>1</sup>

$$\frac{f}{f_0} = \exp(-4\pi M tK/\lambda) \quad (1)$$

where:  $\frac{f}{f_0}$  is the transmittance (ratio of the transmitted to the incident light flux)

$M = M_0 (1-i k)$  is the complex refractive index

---

<sup>1</sup>Numbers in brackets refer to the references at the end of this paper.

$t$  = is the path length through the aerosol  
 $K$  = is the absorption coefficient  
 $\lambda$  = is the wavelength

Since, for other than very black smokes, the absorption coefficient of most smoke particulates is low, the primary phenomenon controlling the extinction of light in most smoke measurements is scattering. Let us now discuss the factors which govern the scattering phenomena.

Scattering of light by particulates is strongly affected by the relationship between the light wavelength and the particle diameter. Figure 3 shows particle size ranges for the three scattering regions encountered in smoke aerosol measurements for visible light [2]. For particles whose diameter is one order of magnitude smaller than the wavelength or less, the scattering phenomena is defined by Rayleigh. For very small, nonabsorbing, spherical particles ( $k=0$ ), where scattering is entirely in the Rayleigh region, the Lambert-Beer law can be written in the form: [3]

$$\frac{f}{f_0} = \exp \left[ - \frac{2 \pi^5 d^6}{3 \lambda^4} \left( \frac{M^2 - 1}{M^2 + 2} \right)^2 Nt \right] \quad (2)$$

where:
 

- $d$  is the particle diameter
- $M$  is the index of refraction
- $N$  is the particle number concentration

In the Rayleigh scattering regime the scattering efficiency is directly proportional to the sixth power of the particle diameter and inversely proportional to the fourth power of the wavelength. It is because of this fourth order wavelength dependence that optical smoke measurement devices using visible light will not respond to particles below a few tenths micron. The use of longer wavelength light in the red or infrared regions such as from lasers or light emitting diodes further reduces the efficiency of scattering in the Rayleigh region.

For particles whose diameter is greater than one order of magnitude larger (actually this boundary varies from  $4\lambda$  to  $100\lambda$  as a function of refractive index, but is generally from  $4\lambda$  to  $20\lambda$  for most smokes) than the wavelength of the incident light (in the Bricard region), the scattering efficiency approaches a limit of two, not one as one might think. The reason this is so is because of diffraction effects at the edges of the particle. That is, a large particle removes from the beam twice the amount of light intercepted by its geometric area. The geometric cross-sectional area of the particle blocks one unit of light, and a portion of the beam not intercepted by the sphere forms a plane wave front from which a region corresponding to the cross-sectional area of the sphere is missing. The diffraction pattern within the shadow area of the particle results in the loss of the second unit of light from the beam. The intensity distribution of the light within this diffraction pattern depends on the shape of the perimeter and size of the particle relative to the wavelength of the light and is independent of composition, refractive index, or the reflective nature of the surface. The total amount of energy appearing in the diffraction pattern is equal to the energy of the beam intercepted by the geometric cross section of the particle.

Mie theory explains the phenomena of scattering taking place where the particle diameter and wavelength of light are of the same order of magnitude. Expressions for scattering and extinction in the Mie region are obtained by solving Maxwell's equations for the regions inside and outside the sphere and are found to be a function of the particle diameter and complex index of refraction alone. Due to the complexity of the governing equations, the calculations must be carried out numerically with the results tabulated for specific values of refractive index.

### 3. CURRENT PHOTOMETER DESIGNS

Most photometers used for smoke density measurement employ the same basic design, represented in figure 4. They use a light source (usually a tungsten filament lamp) in a direct optical line with a light-receiving

element. The light source and receiver are rigidly mounted some known distance apart and are enclosed in a darkened testing chamber or shielded in some way to reduce the influence of ambient light.

The light source is normally operated from a highly stable, constant voltage source at somewhat less than rated voltage. The output of the cell is normally monitored with a high quality meter of proper impedance so as to operate the cell within its linear range.

In most cases the photometer is adjusted at the beginning of each test so that the meter reading is some specific value. This facilitates the use of a chart for conversion to whatever smoke density units are being used without having to calculate the values each time. This adjustment is normally made by varying the voltage applied to the lamp, and is a major source of error in design and operation.

Adjusting the voltage across the lamp changes the filament color temperature and thus changes the wavelength distribution of the light being produced. Since light scattering intensity is an exponential function of the wavelength of the light, this results in major variations in the readings obtained under different voltages even when using the same photometer. In order to eliminate variations in readings from a single photometer or variations between photometers it is imperative that tungsten filament light sources be operated at the same filament color temperature. Figure 5 shows the variation in apparent optical density with changing light wavelength (using an adjustable monochromatic source) for white and black smokes (at constant particle concentration) as developed at the British Fire Research Station [4]. From this data, a change in wavelength from 1.0  $\mu\text{m}$  to 1.5  $\mu\text{m}$  results in a 50% reduction in apparent optical density for white smoke and a 30% reduction for black smoke. This difference is reasonable since the extinction reading for white smoke would be more dependent on scattering and the reading for black smoke would be more dependent on absorption.

Another method of assuring a constant wavelength light would be to use an essentially monochromatic source, such as a light-emitting diode, laser, or a tungsten filament lamp with an optical filter passing one frequency. Because of their very low light output, light emitting diodes can only be used in very short path lengths (a few inches). Lasers produce sufficient light output, but cost prohibits their use where a large number of photometers are necessary and would prohibit their use in large scale testing where damage to the laser would be possible from the test fire. Thus, the only practical solutions would be operation with white light at a constant color temperature or use of monochromatic light.

Since the intensity of the light source cannot be adjusted to a specific starting point without changing the filament color temperature, the sensitivity adjustment should be made by controlling the output of the light receiving element. This can easily be done by adjusting the gain of an amplifier in the output circuit. The use of a linear amplifier would be necessary in this case.

While operation of the light source at a reduced voltage is advantageous in increasing lamp life, it is imperative that the lamp be operated with direct current since reduced voltage alternating current applied to a tungsten filament lamp results in filament notching, which can actually reduce life. In addition to reducing life, this notching effect can result in a change in the light wavelength output due to the creation of "hot spots" on the filament.

The light source and receiver used should be matched for spectral response and the receiver should be operated in the linear region of its response curve. The light beam should be highly collimated and should be as small in diameter as possible to reduce the effect of multiple scattering, especially in side lobes. The light receiver should be designed with lenses so as to have as narrow a viewing angle as possible, which will reduce the effect of ambient light. Where high ambient light levels are unavoidable, chopping techniques can be used to make the output insensitive to the ambient signal. Care must also be taken to eliminate

lamp filament projection on the light receiver, which produces nonlinearities in the output. This reduction in accuracy is caused by the filament projection causing dark areas on the receiver during clear conditions which gradually disappear as the light is diffused through the smoke.

#### 4. PROTOTYPE PHOTOMETER: DESIGN DESCRIPTION AND DISCUSSION

Once the problems with existing photometers had been identified, modifications were undertaken to eliminate these problems. This has resulted in the following design.

The light source selected is a number 1810 lamp with a T-3/4 bulb and a miniature bayonet base. This lamp is rated 6.3 volts, 0.40 amps, 1.5 candela, 3000 hour life. The lamp is mounted behind a +20 diopter, double convex collimating lens and is focused to produce maximum light on the receiver. The lamp is operated at 5 volts dc (which gives a 2425°K color temperature), [5], regulated by use of a 7805, series pass regulator mounted at the lamp. The regulator is mounted at the lamp so as to reduce variations in voltage due to cable length. A photograph of the light end of the instrument is figure 6.

The light receiver chosen is a 1P39 phototube (with a filter to correct its spectral response to the standard CIE curve for the human eye response peaking at 550 NM) mounted just ahead of the focal point of a +10 diopter plano-convex lens. The inside of the housing containing the phototube is painted optical black to minimize internal reflections. Figure 7 shows the instrument receiver.

A typical two-channel amplifier schematic is shown in figure 8. The output of the phototube is connected by means of a shielded cable to a FET input, linear, operational power amplifier (40 J) which is operated as a current to voltage converter with an adjustable gain of approximately  $10^6$ . The control panel contains a zero, and coarse and fine span adjustments. The zeroing is done with the operational

amplifier null connection. The coarse and fine span adjustment consists of two potentiometers in series serving as the feedback resistance of the amplifier. A 10-turn potentiometer was selected for the fine adjust to reduce adjustment criticality.

The system is designed to provide an adjusted 1.000 volt signal in clear air conditions. While higher voltages can be obtained if desired, increasing the gain of the operational amplifier results in increased effect of ambient light on the reading.

While the use of 1.000 volt reference signal will give an output in percent transmittance over the beam path length, it is sometimes more convenient to have an output directly in the final engineering units, such as optical density. For this purpose a second amplifier stage may be added using a commercially available Log ratio amplifier. The schematic for this amplifier stage is shown in figure 9.

The voltage transfer equation for this circuit is:

$$e_{out} = \frac{1}{t} \text{LOG} \frac{e_{ref}}{e_{sm}} \quad (3)$$

where:

- $e_{out}$  = circuit output voltage in proper engineering units
- $e_{ref}$  = set to the clear air photometer voltage
- $e_{sm}$  = output of the photometer amp.
- $t$  = conversion circuit gain set to equal the reciprocal of the path length by eq. 4

Comparing this with the equations for optical density, it can be seen that the photometer output is converted directly to optical density per unit length or unit optical density (where  $t=1$ ). For optical density where  $t \neq 1$ , a fixed value resistor ( $R_d$ ) is used. The value of resistance is calculated from:

$$R_d = 16.7 (1/t) - 1 \text{ (K}\Omega\text{)} \quad (4)$$

where  $t$  is the beam path length in the desired units. For unit optical density (or where  $t=1$ ) the lv/decade pin is connected to the output pin.

To use the circuit, the output of the smoke meter amplifier is connected to the  $e_{sm}$  terminals and  $e_{ref}$  is set to 1.000 volts (or whatever reference voltage is used). The output ( $e_{out}$ ) is then in the proper engineering units. The Log ratio module is calibrated using the calibrate potentiometer and a neutral density filter of known optical density.

It has been found that once the lamps have been "burned in" for approximately 24 hours, they need only be warmed up for approximately one hour to obtain stable operation. Full-scale output variation appears to be less than  $\pm 1$  millivolt per volt.

Three photometers of one meter length and a three-channel amplifier using this design were built for evaluation. The meters were calibrated using gelatin (Wratten) filters in the range of 0.1 to 1.0 optical density. Tests showed that all three meters read precisely the same with each filter when placed in the same position along the one meter length. The results for the calibration are shown in figure 10. The stability of the system allows its use without drift error to one millivolt accuracy. This results in accurate measurements to within  $\pm 0.0004$  optical density per meter (due to the low output variation).

In working with the initial prototypes, it was found necessary to use a shielded cable between the control and the phototube when running cable lengths over about one meter. This is due to the high impedance of the phototube and the high amplifier gain.

It was also found necessary to operate the lamp circuit from a pure dc supply which never drops lower than 10 volts. Although the series pass regulator would give rough regulation from a full-wave-rectified, unfiltered power supply, the switching times of the regulator were so



short that whenever the supply fell below 10 volts dc, regulation was lost and an imperceptible flicker was obtained which caused instability in the output. This should be avoided either by operating from a pure dc supply or using a capacitor smoothed, full-wave-rectified supply of a high enough voltage such that the circuit output voltage never falls below 10 volts. Since the regulators are capable of handling an input voltage as high as 35 volts dc, a 28 volt, full-wave-rectified supply with a large smoothing capacitor is capable of operating the system satisfactorily.

The 200-volt bias supply for the phototubes does not require as critical a regulation as the lamp supply. It is necessary, however, to use a fairly large smoothing capacitor to minimize ripple which injects a 60 Hz noise in the amplifier output. The effect of this noise may be significant if the output device does not have a 60 Hz rejection filter.

The phototube also has the advantage of more thermal stability than any other type of receiving device. The 1P39 is rated as stable to temperatures as high as 70°C. Above this temperature the output increases sharply, doubling every 3 to 5°C [6]. At about 190°C, the cathode begins to decompose by driving off cesium. This decomposition is only partially reversible, so any tube which may have exceeded 190°C should be replaced.

Keeping the 1P39 below 70°C can be accomplished in several ways, depending on the peak expected temperature and exposure time. For short exposures, insulation of the receiver box will slow the heat transfer enough to maintain the tube below the critical temperature. For higher peak temperatures or longer exposure times, purging the receiver box with cool air or nitrogen may be necessary. If you are unsure of your methods, it is good practice to place a thermocouple on the rear of the tube to indicate the time at which the tube has exceeded its critical temperature. Readings taken after this point should be disregarded.

If a silicon cell is used as a receiver, it must be operated into an effective short circuit to maintain thermal stability. Where long

cable runs are made, this would necessitate use of a preamplifier in the receiver box. The critical temperature for the cell and amplifier must then be determined, and similar steps must be taken to keep the receiver temperature below this value.

A particular advantage to the design proposed above is that the entire photometer (exclusive of control) can be built at moderate cost. Thus, it is no great concern if one of these photometers is destroyed during a full-scale test. This allows positioning of the photometer in the most advantageous locations without concern for its protection.

An additional point about this particular design is that the light source chosen, when operated at 5 volts, has an estimated life of nearly five years [7]. Thus it is possible to let the lamps run continuously without worry of burning out bulbs.

##### 5. THE NEED FOR A REFERENCE IONIZATION CHAMBER

As was stated earlier, optical measurement methods can be used to measure particulates only down to the few tenths micron range, due primarily to the fourth order dependence on the particle diameter to wavelength ratio. In tests where the smoke measurement is only being used to approximate vision obscuration and thus the potential for escape through the fire or smoke filled areas, these light extinction measurements are sufficient. If, however, quantitative evaluation of the response of ionization type smoke detectors is desired, smoke measurements down at least one more order of magnitude in particle diameter are necessary. This is true simply because changes in the numbers of particles in the 0.01 to 0.1 micron range would grossly affect the ionization detector response without resulting in significant changes in the reading of the photometer. The recognition of this fact has resulted in the development of a number of instruments using ionization chamber sensors to make measurements in this lower size range. The theoretical relative sensitivity of scattering, extinction, and ionization chambers as a function of particle size for constant mass concentration is given in figure 11 [8].

Many manufacturers of ionization type smoke detectors have produced units with analog output signals which can be read on meters. One such device is shown in figure 12. While these devices all give relative readings, they typically relate well only to the exact detector from which they are made. The reason for this is that the sensing chambers in commercially produced detectors are optimized for cost and ease of manufacture, and are not designed to perform strictly according to ionization theory. Such critical design parameters as electrode spacing, chamber volume, source strength, uniformity of ionization and electric fields, and effects of outside air currents are not, and cannot be, as closely controlled as is necessary in a measuring instrument, due to cost considerations. Thus, these devices are not acceptable as precision laboratory instruments.

Because of these facts, several attempts have been made to design reference instruments. The first such instrument which we have identified was designed by Dr. Hosemann at Aacher University [9] and is shown in figure 13. While Dr. Hosemann and his colleague Dr. Krause have had good results with this chamber, attempts to reproduce it have not been so successful. In fact, critical alignment of internal parts has resulted in a situation where, when disassembled for cleaning, Dr. Krause must personally reassemble and calibrate the chamber to get it to operate properly.

Mr. Peter Burry at the British Fire Research Station at Borehamwood, England developed a chamber commonly known as the separated charge chamber [10]. A schematic representation of this chamber is shown in figure 14. While he found that his chamber was reproducible and noncritical in assembly, experimentation showed that its inherent sensitivity was much too high. This resulted in a total loss of chamber current at particle concentration levels below those normally encountered in detector testing. This chamber is now being used for measuring particulate concentrations of air pollution and background particle levels in non-fire situations.

These problems with the earlier two reference chambers led Dr. Andreus Scheidweiler of Cerberus AG in Mannedorf, Switzerland to

develop a third instrument, shown in figure 15. Early results of tests conducted with this instrument seem to indicate that the problems of the earlier two have been solved. The instrument is reproducible and non-critical and will operate properly at particulate concentrations normally encountered in smoke detector testing. Copies of this instrument have been purchased by Krause at Aachen, Burry at Borehamwood, and ourselves; and it is currently being evaluated as to its suitability as a reference instrument. At this point we feel that this device shows great promise, but we are not yet ready to propose its adoption as an industry standard. Details of the operation of this device are given in reference 11, a paper by Dr. Scheidweiler.

## 6. FUTURE NEEDS

Use of a reference ionization chamber in conjunction with a reference extinction beam photometer will allow a fairly good approximation of mass median particle size and number concentration, and should allow good quantitative correlation to the operation of most smoke detectors. Therefore, using these two instruments in concert gives much more information than either one alone. The question arises as to whether the use of additional instruments is advisable. There is one other important parameter of the particulate cloud relating to photoelectric detectors which these two instruments do not quantify. This is the angular scattering intensity (at a given angle). Figure 16, for example, shows such an angular scattering intensity distribution for polydisperse spheres with a refractive index of 1.33 [12] and compares the distribution predicted by Mie theory to the sum of the diffraction, refraction and reflection components.

Photoelectric detectors look at the light scattered from the smoke particles at a specific angle. With the extinction beam photometer light scattered at any angle does not reach the receiver. As the refractive index of an aerosol changes, the intensity at any given angle can change without affecting the total scattered light and thus not affect the photometer. Therefore, it is theoretically possible to expose a photoelectric detector to smokes from two different sources which give the same reading on both the extinction beam photometer and ionization chamber

but cause different results in the detector response. Even though this is theoretically possible, photoelectric detectors, in general, do seem to correlate well to the extinction beam photometer for most cases. It is hoped that this effect is not important enough to warrant the addition of scattering readings as these would have to be taken at the exact angle used by the detector optics. Since scattering angles in commercially available detectors vary from  $90^\circ$  to less than  $27^\circ$  from forward, this would involve a multiplicity of readings and greatly increase the complexity of the instrument. Such an instrument has been developed at the National Bureau of Standards for research on smoke aerosol characteristics and is shown in figure 17.

One possible future need might be a reference gas detector. In the last few years, gas sensing fire detectors have been proposed. While current units do not seem to be suitable for general applications, there is some evidence that they may be quite effective in some special applications, such as detecting fires in electronic equipment. Figure 18 summarizes the results of tests of three types of fire detectors in computers in Japan [13]. This figure gives success percentages for ionization, photoelectric, and gas detectors located inside a computer, in the subfloor, and on the ceiling of a test room. A number of computer fire simulations were conducted, and success was defined as detection occurring before an error was generated in the computer program due to the fire. Newer gas detection principles, or better information on application of existing principles such as these Japanese tests, may result in more general acceptance of gas sensing fire detectors. One of the biggest stumbling blocks, however, is the lack of general information on gaseous species and concentrations in fire testing. Without this information it is impossible to determine what gases and what concentrations of these gases must be detected for satisfactory performance. Thus, if an instrument such as a total hydrocarbon analyzer were added to the instrumentation of many full-scale fire tests, relative data could be obtained which may demonstrate certain areas of application in which gas sensing fire detectors could be used.

In conclusion, it is felt that the rapidly growing amount of large and small scale fire testing being conducted in this and other countries could be of much greater overall benefit if standardized instrumentation were used which allows proper comparison of tests conducted by different parties. Such comparisons would alleviate the need for duplicate testing and allow a much more rapid attainment of an understanding of the fire phenomena.

#### 7. REFERENCES

- [1] Hodkinson, J. R., The optical measurement of aerosols, Aerosol Science, edited by C. N. Davies, Academic Press, London, 1966, Chap. 10, 290.
- [2] Hodkinson, J. R., The optical measurement of aerosols, Aerosol Science, edited by C. N. Davies, Academic Press, London, 1966, Chap. 10, 316.
- [3] Cadle, Richard D., The Measurement of Airborne Particles, John Wiley and Sons, 1975, Chap. 4, 236.
- [4] Fire Research, Annual Report of the British Fire Research Station, 1971, 63.
- [5] G. E. Miniature Lamp Division, private communication.
- [6] Kissinger, G. D., RCA Electronic Components, Phototube Applications Section, private communication.
- [7] G. E. Miniature Lamp Catalog 3-6253, Revised 12/72, 4.
- [8] Purt, G., Specific fire risk factors and their significance for automatic fire detection, Fourth International Fire Protection Seminar, Zurich, 1973.

- [9] Hosemann, J. P., Considerations in testing smoke detectors, Symposium on Problems of Automatic Fire Detection, 1971 Aachen Conference, Aachen, Germany, Oct. 4-6, 1971.
- [10] Burry, P., The separated ionization chamber, Proceedings of the Symposium on Fire Detection for Life Safety, National Academy of Sciences, 1977.
- [11] Scheidweiler, A., The ionization chamber as a smoke dependent resistance, NFPA Fire Technology, May 1976.
- [12] Hodkinson, J. R., The optical measurement of aerosols, Aerosol Science, edited by C. N. Davies, Academic Press, London, 1966, Chap. 10, 325.
- [13] Report of computer fire tests, Joint Group on Computer Fire Protection, J. of the Japanese Association of Fire Science and Engineering, Vol. 24, No. 3, 1974 (In Japanese; English translation available from the author of this paper).

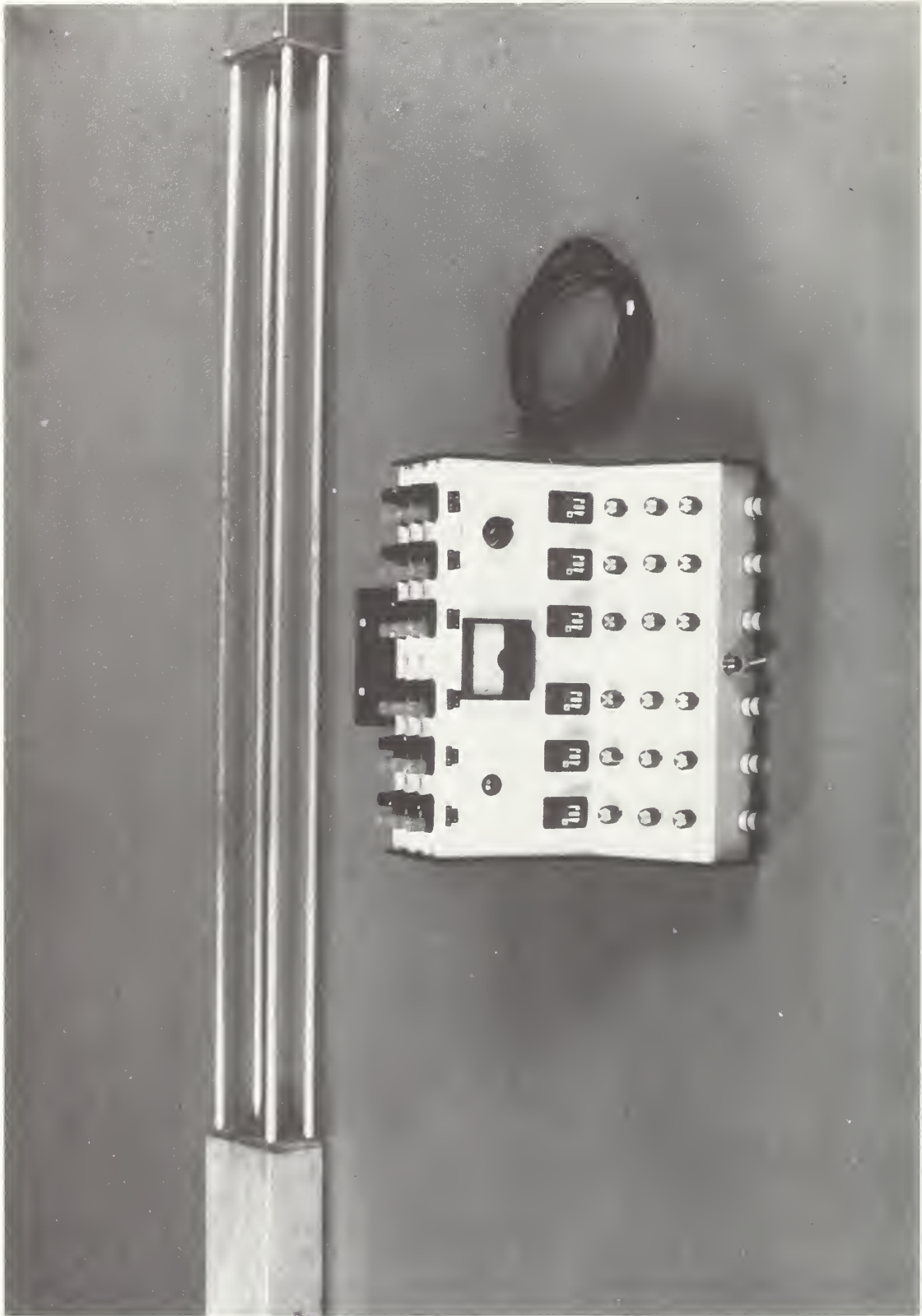

Figure 1. NBS extinction beam photometer and six-channel control



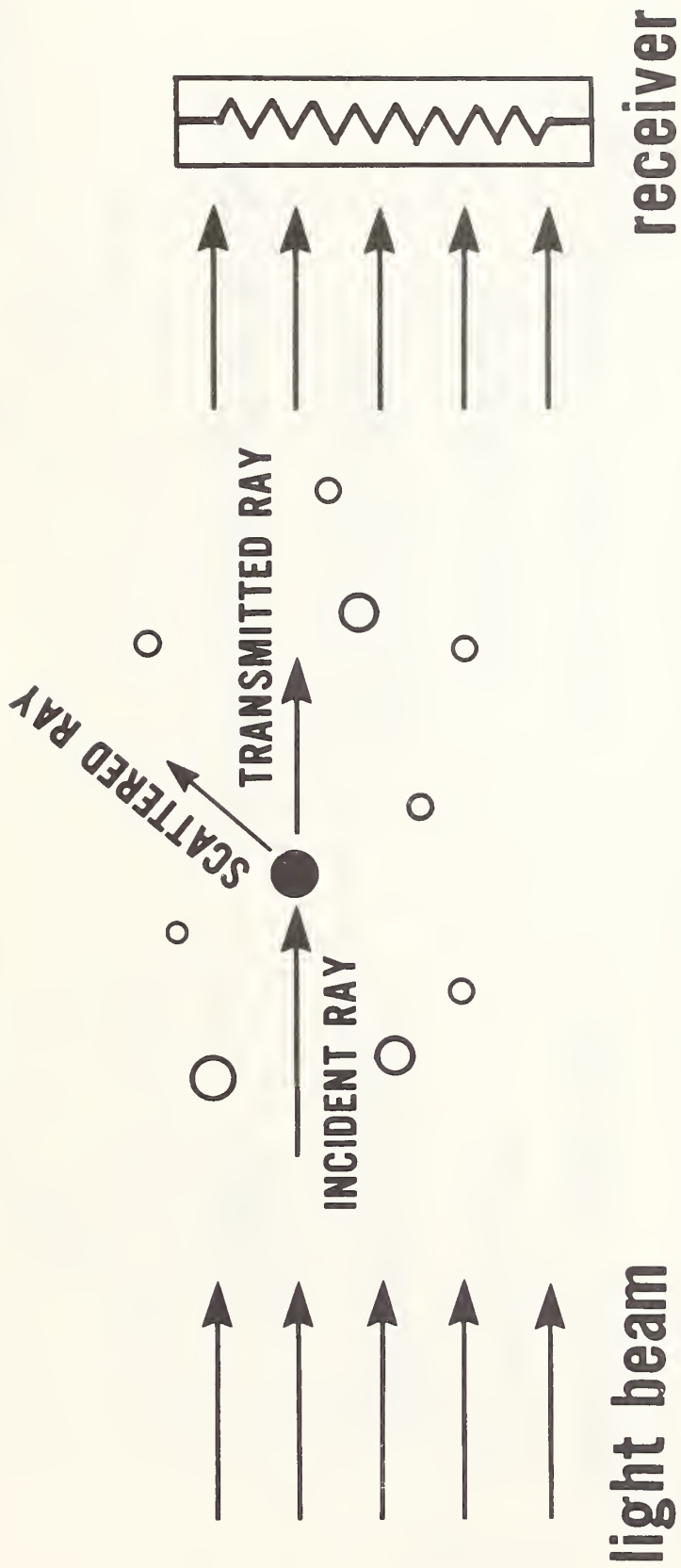

Figure 2. Light scattering and extinction by a particle

<b>FOR VISIBLE LIGHT</b>	<b>(<math>\lambda \approx 0.5 \mu\text{m}</math>)</b>
<b>PARTICLE DIAMETER</b>	<b>APPLICABLE THEORY</b>
$d < 0.05 \mu\text{m}$	Dipole (Rayleigh)
$0.05 \mu\text{m} < d < 2 \mu\text{m}$	Intermediate (Mie)
$d > 2 \mu\text{m}$	Absorption-Diffraction (Bricard)

Figure 3. Theory of optical smoke measurements

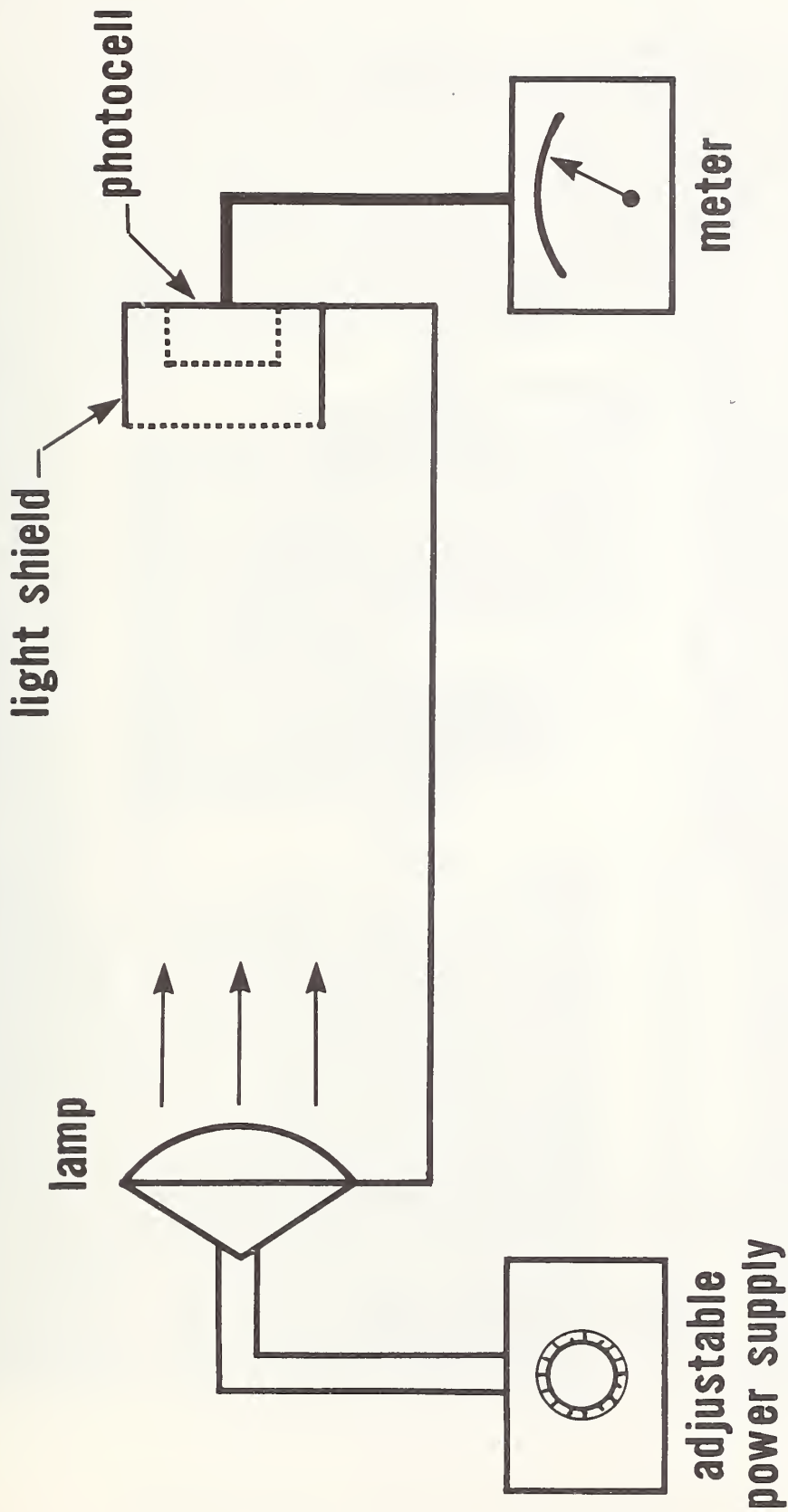

Figure 4. Typical photometer design

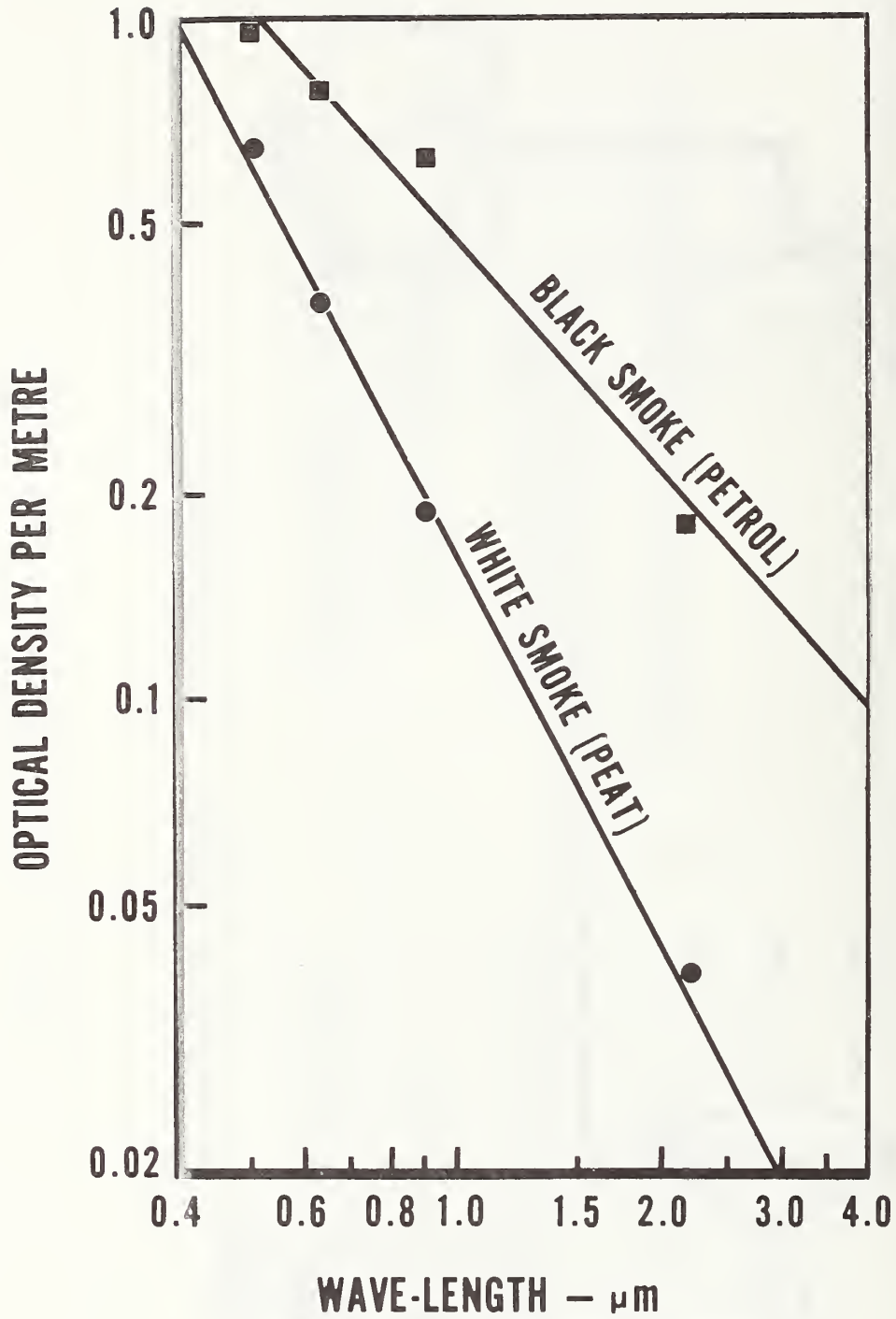

Figure 5. Variation of optical density with wavelength for typical black and white smokes

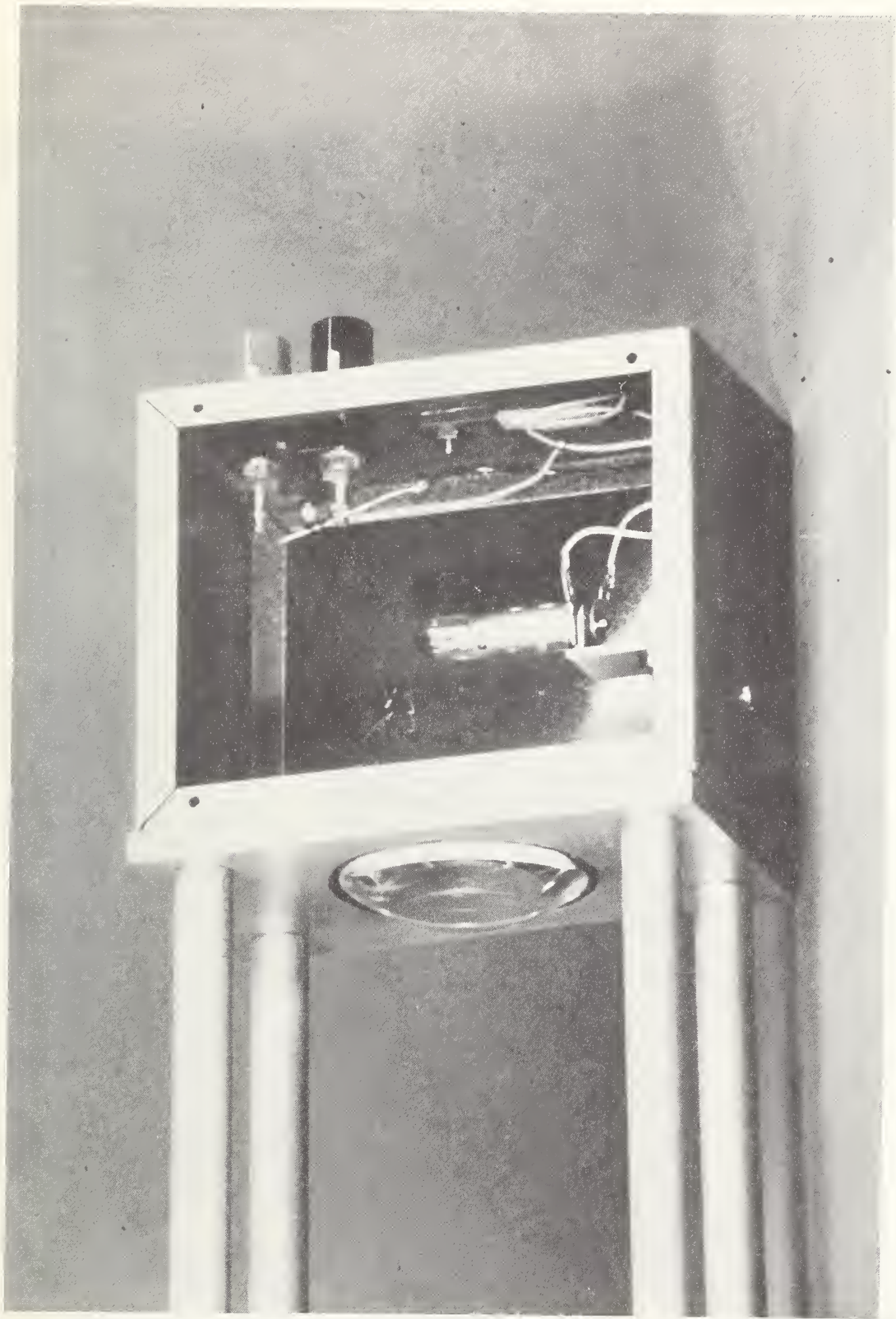

Figure 6. NBS extinction beam photometer light source

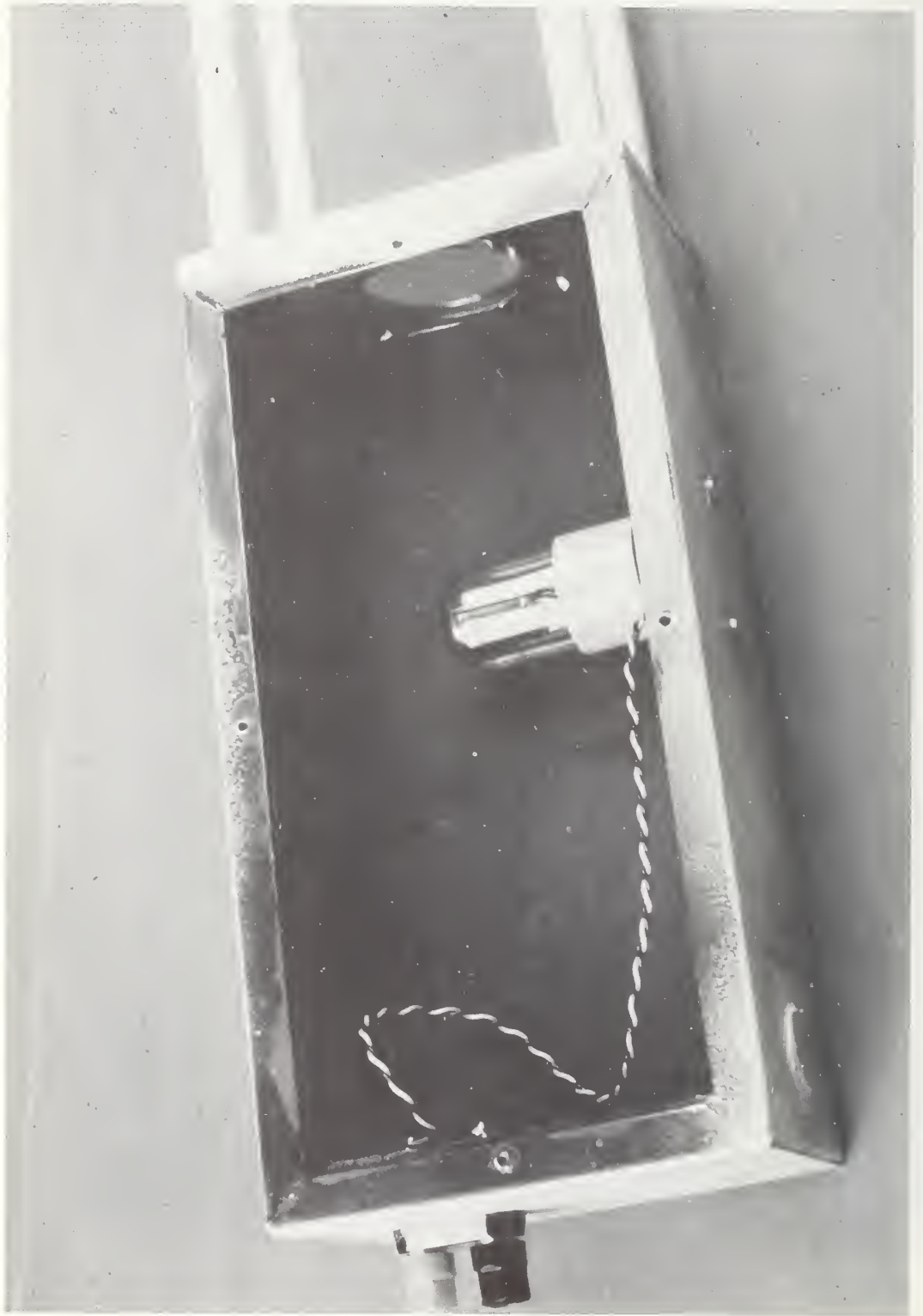

Figure 7. NBS extinction beam photometer receiver

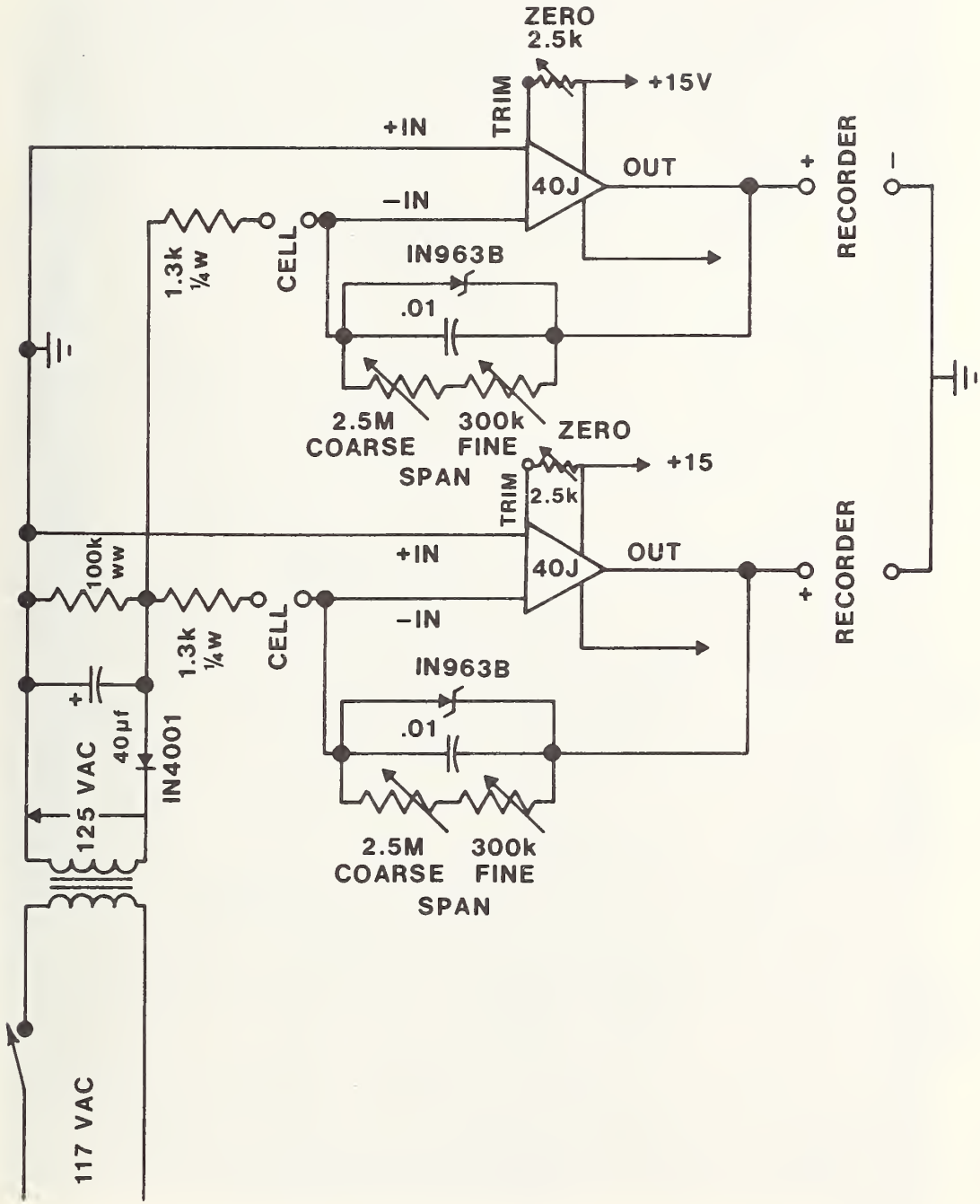

Figure 8. Typical schematic - two-channel amplifier

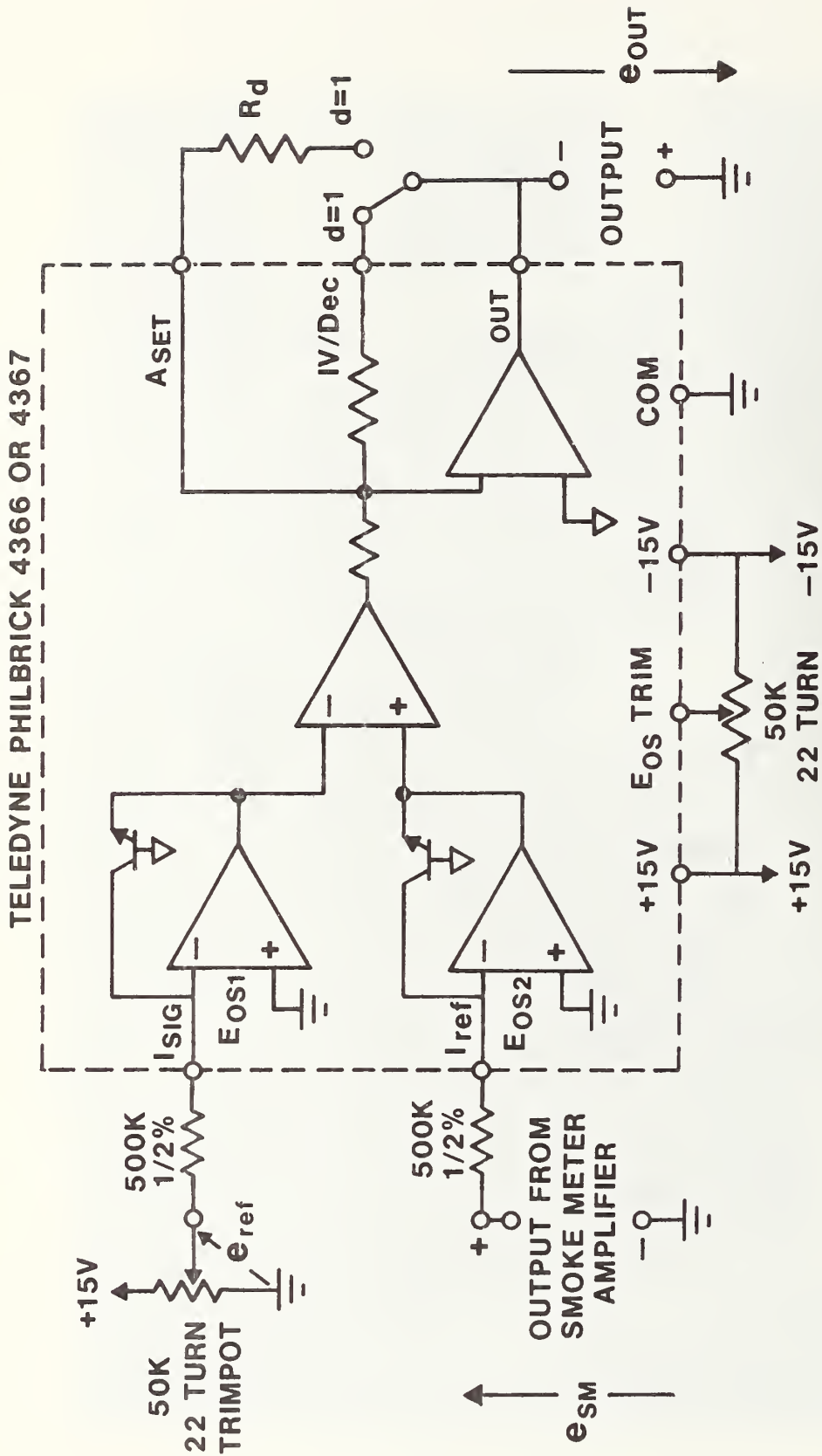

Figure 9. Circuit for converting percent transmittance to optical density or optical density per unit length



# PHOTOMETER CALIBRATION

FILTER (Optical Density NOM)	CALIBRATED READINGS* (Volts NOM)	METER 1 (Volts)	METER 2 (Volts)	METER 3 (Volts)
NONE	1.000	1.000	1.000	1.000
0.1	0.796	0.796	0.796	0.796
0.2	0.626	0.626	0.626	0.626
0.3	0.480	0.480	0.480	0.480
0.4	0.398	0.398	0.398	0.398
0.6	0.231	0.231	0.231	0.231
0.8	0.153	0.153	0.153	0.153
1.0	0.093	0.093	0.093	0.093

\* Transmittance of filter at 550 NM (Peak spectral sensitivity for CIE curve)

Figure 10. Test results - photometer calibration with neutral density filters

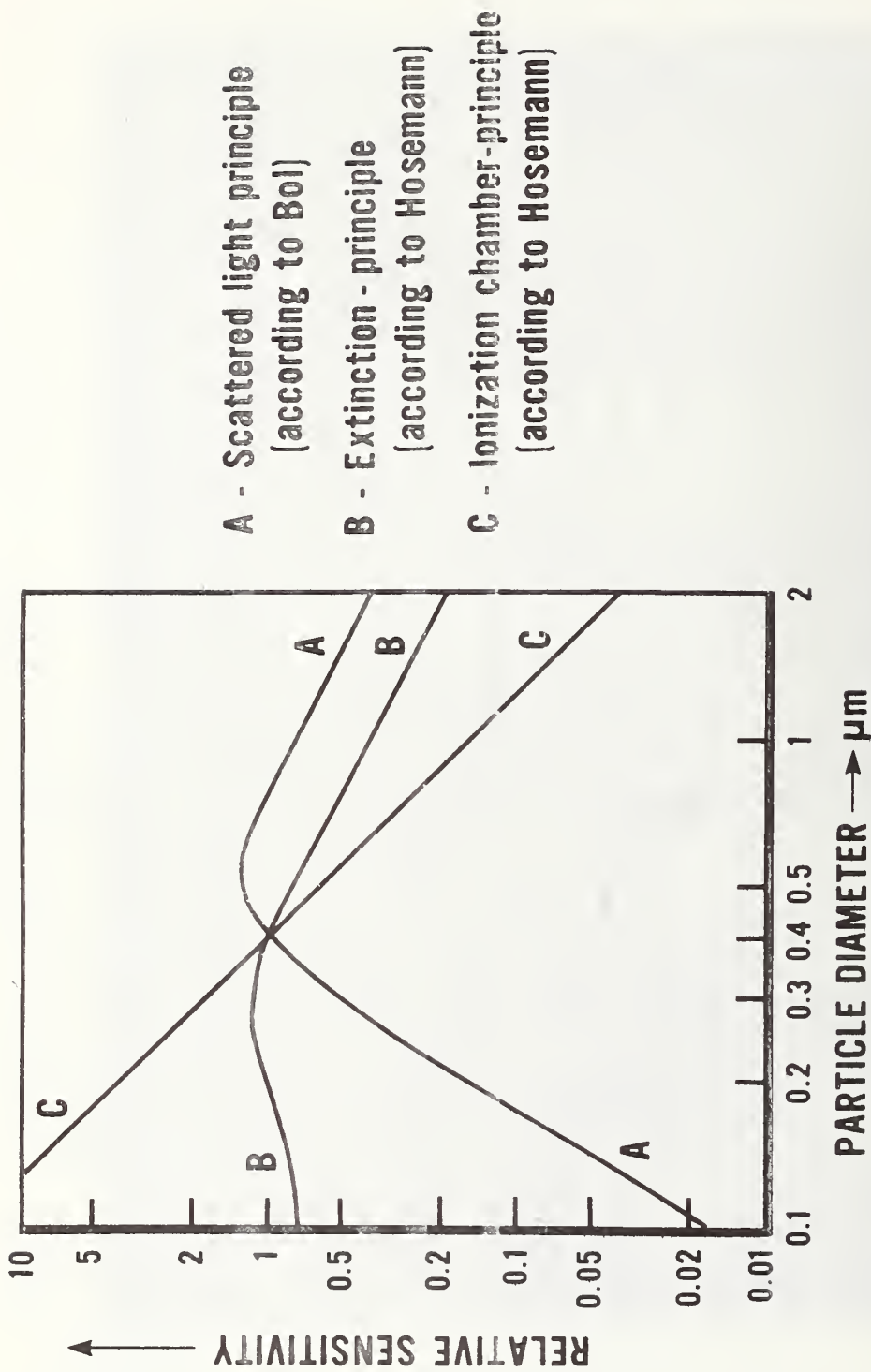

Figure 11. Relative sensitivity of various detection principles for constant mass concentration

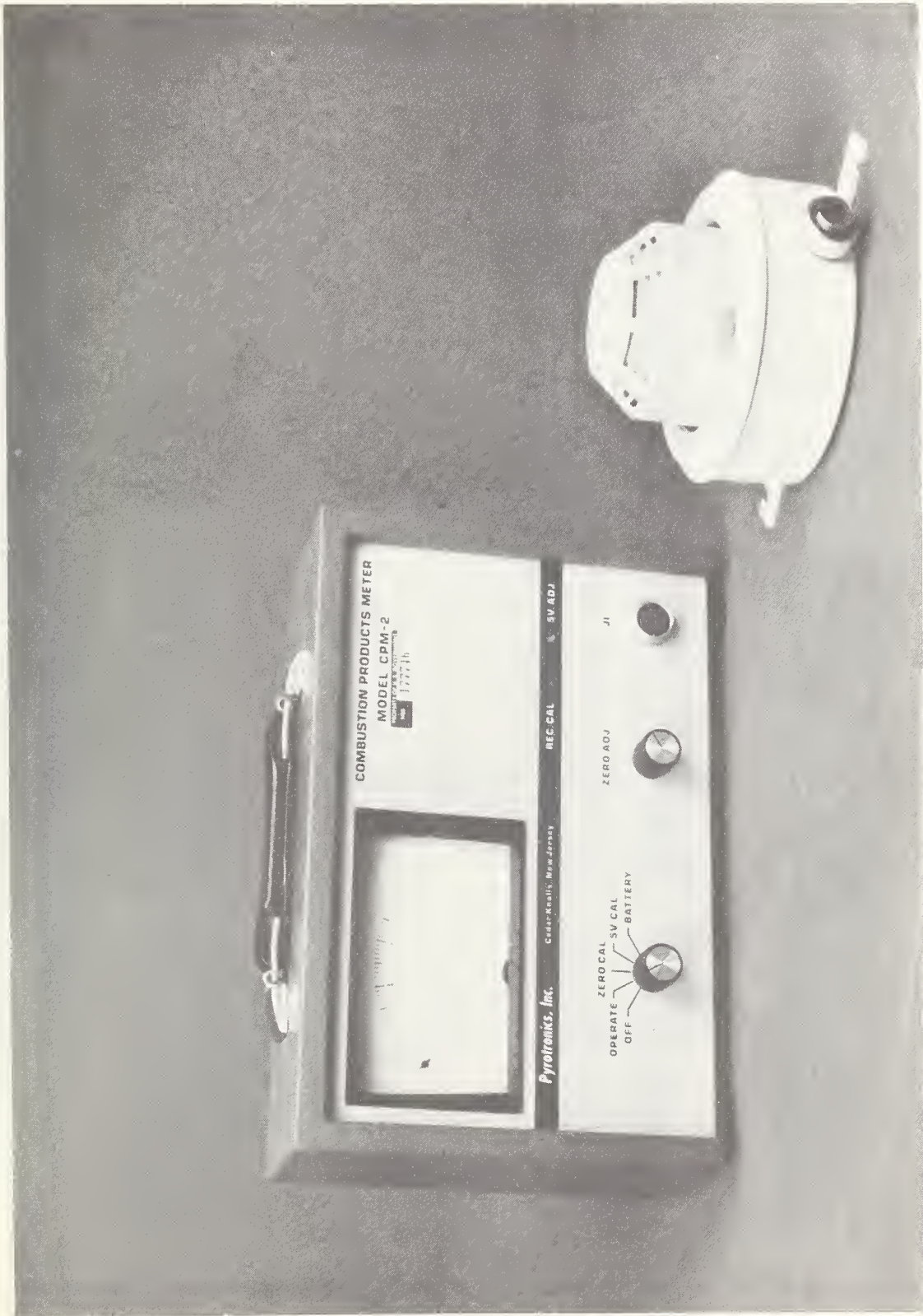

Figure 12. Reference ionization chamber based on a commercial detector

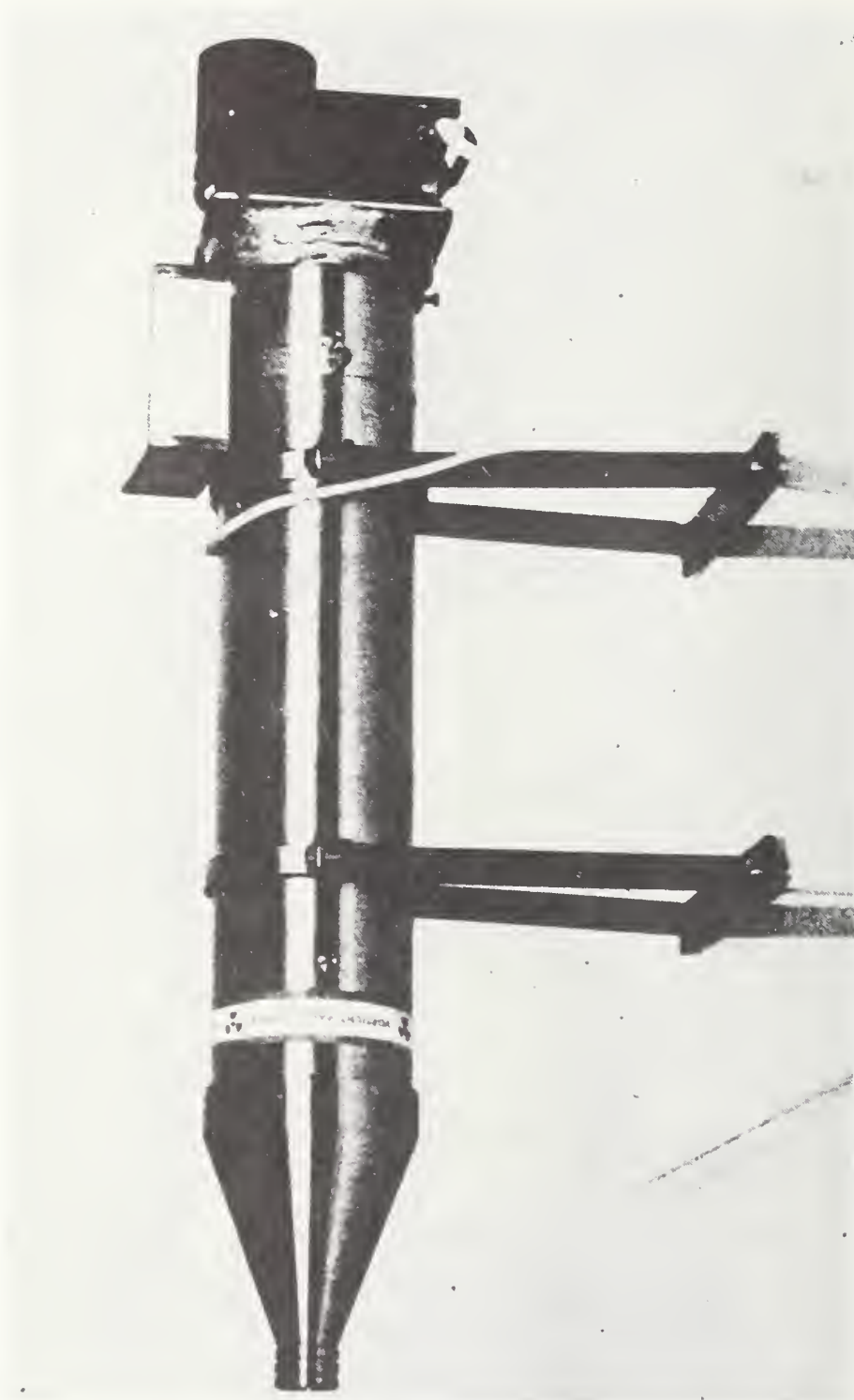

Figure 13. Hosemann reference ionization chamber

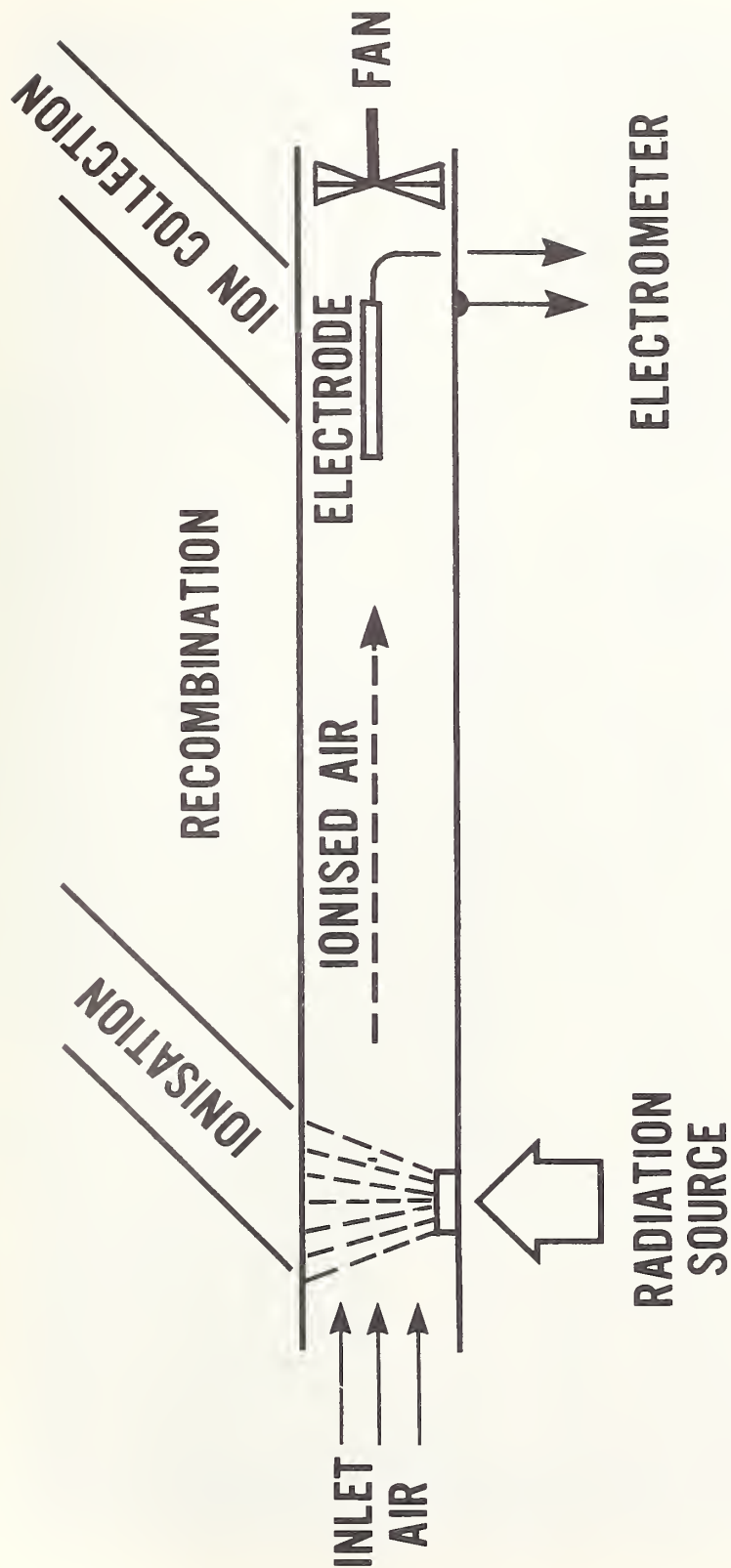

Figure 14. The separated ionization chamber

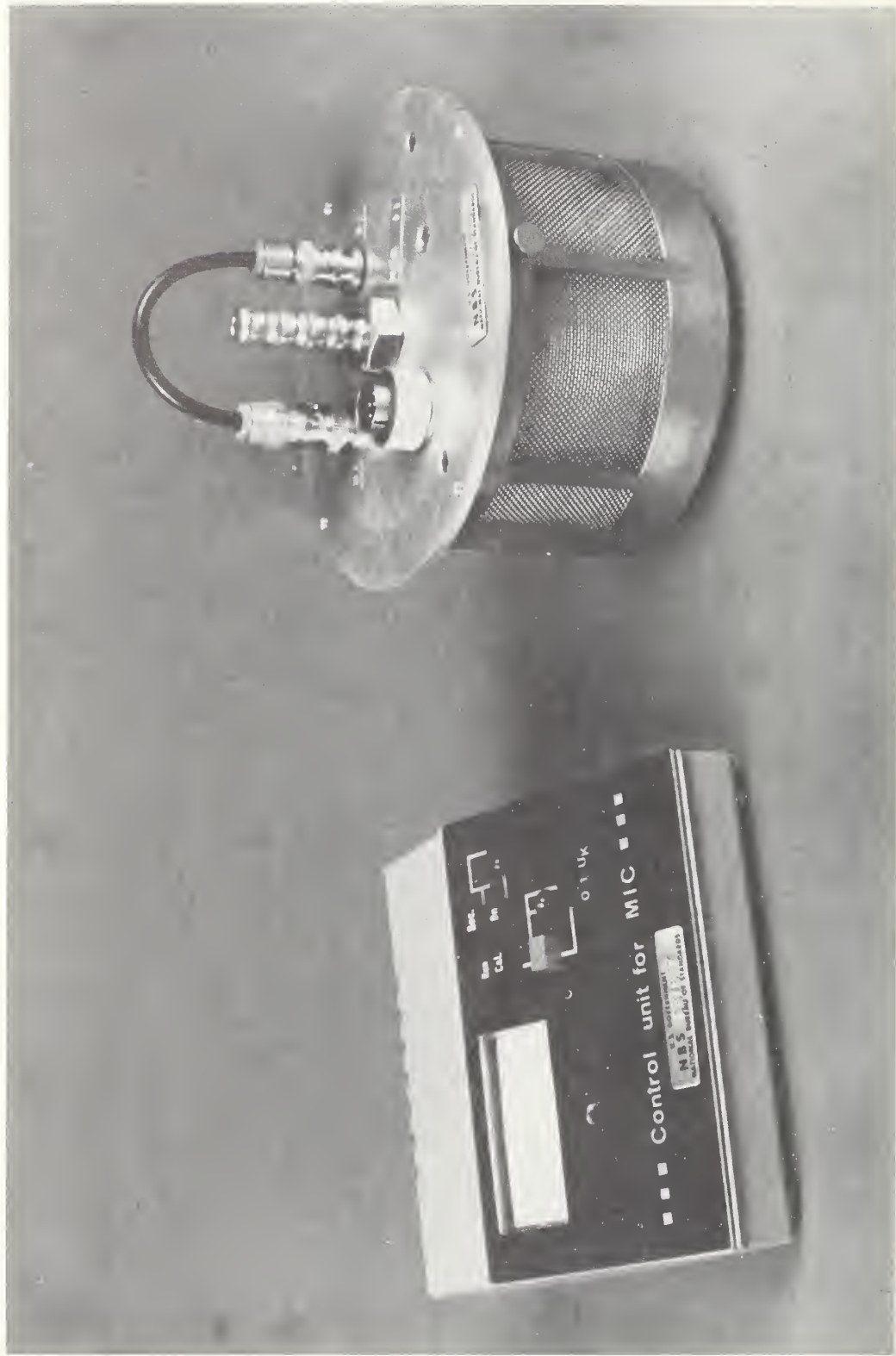

Figure 15. The Cerberus measuring ionization chamber

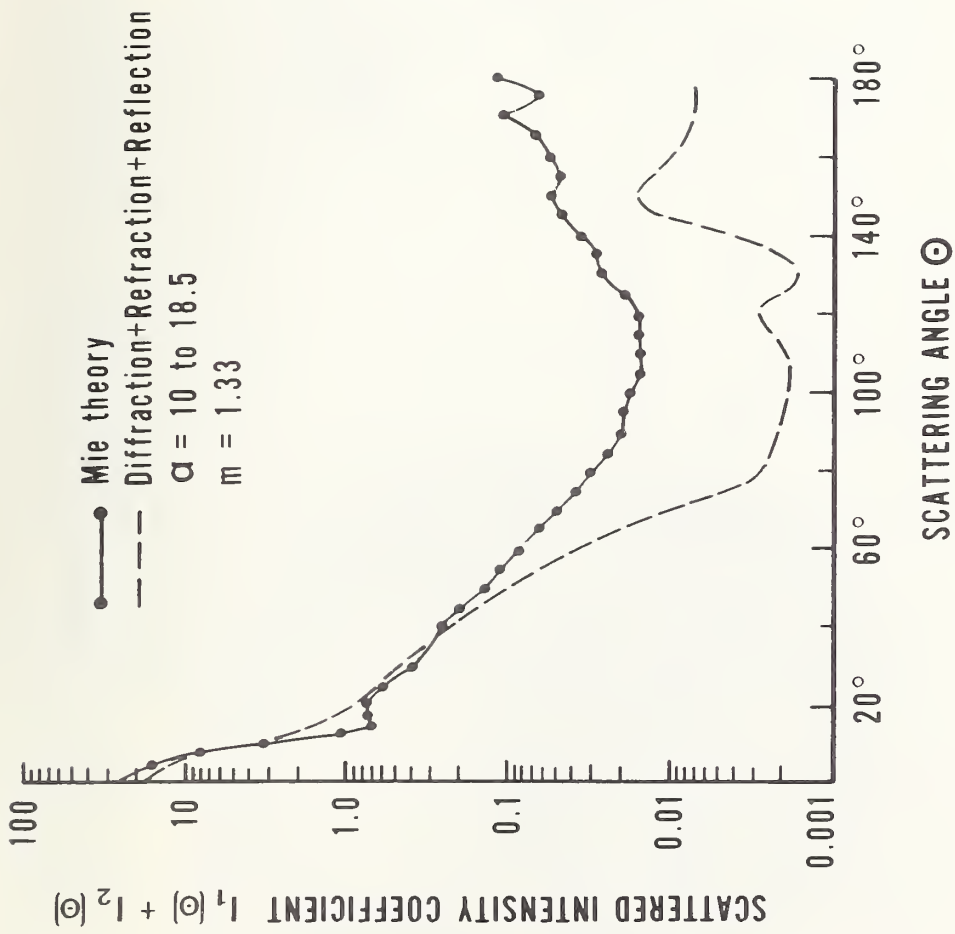

Figure 16. Mie scattering by polydisperse spheres compared with diffraction, refraction, and reflection as a function of scattering angle

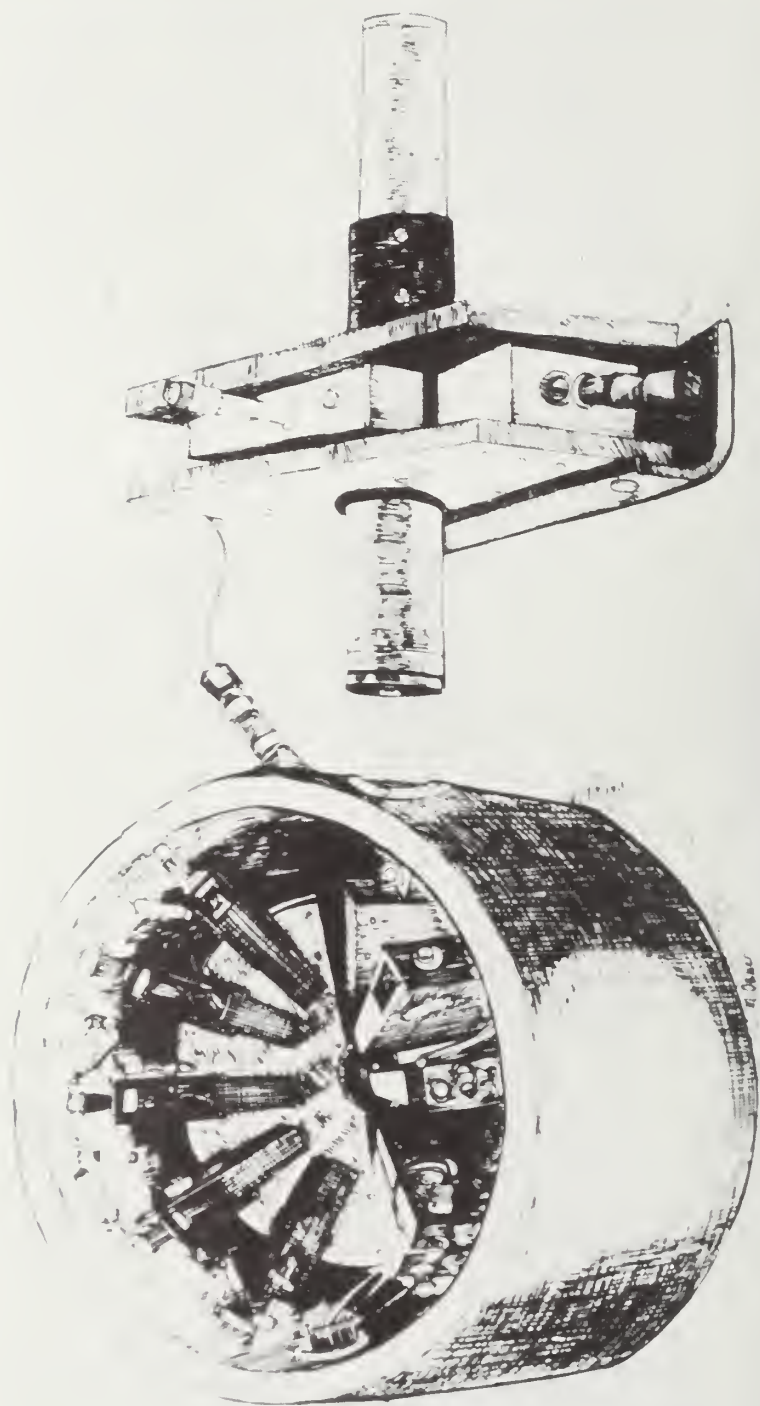

Figure 17. The Sinnott-Gravatt multiple scattering instrument



		DETECTOR LOCATIONS								
		INSIDE MACHINE		UNDER FLOOR		ON CEILING				
FIRE LOCATIONS		I	P	G	I	P	G			
	EQUIPMENT FIRES	60	60	50	30	10	10	40	30	10
	UNDERFLOOR FIRES	0	100	75	100	100	50	25	100	0
	ALL FIRES	37	79	58	63	42	26	53	63	32

NOTE: I, P, G, ARE IONIZATION, PHOTOELECTRIC & GAS DETECTORS

Figure 18. Japanese computer fire tests-success percentages

U.S. DEPT. OF COMM. <b>BIBLIOGRAPHIC DATA SHEET</b>	<b>1. PUBLICATION OR REPORT NO.</b> NBSIR 78-1502	<b>2. Gov't Accession No.</b>	<b>3. Recipient's Accession No.</b>
<b>4. TITLE AND SUBTITLE</b> SMOKE MEASUREMENTS IN LARGE AND SMALL SCALE FIRE TESTING		<b>5. Publication Date</b> October 1978	<b>6. Performing Organization Code</b>
<b>7. AUTHOR(S)</b> Richard W. Bukowski		<b>8. Performing Organ. Report No.</b>	
<b>9. PERFORMING ORGANIZATION NAME AND ADDRESS</b> NATIONAL BUREAU OF STANDARDS DEPARTMENT OF COMMERCE WASHINGTON, D.C. 20234		<b>10. Project/Task/Work Unit No.</b> 4928677 (7528677)	<b>11. Contract/Grant No.</b>
<b>12. Sponsoring Organization Name and Complete Address (Street, City, State, ZIP)</b> Same as No. 9		<b>13. Type of Report &amp; Period Covered</b> Final Report	<b>14. Sponsoring Agency Code</b>
<b>15. SUPPLEMENTARY NOTES</b>			
<b>16. ABSTRACT (A 200-word or less factual summary of most significant information. If document includes a significant bibliography or literature survey, mention it here.)</b> The extinction beam photometer is the most widely used instrument for taking smoke measurements in fire testing. Most existing designs were found to be inaccurate and unreliable for measurements where smoke detection performance is evaluated due to the low levels of smoke present at activation. Accordingly, a new extinction beam photometer design was developed which will provide the stability and accuracy necessary for these measurements. The paper describes the new design and proposes its adoption as an industry standard.  The paper also discusses the need for a reference ionization chamber instrument and a reference measurement which relates to gas sensing fire detectors.			
<b>17. KEY WORDS (six to twelve entries; alphabetical order; capitalize only the first letter of the first key word unless a proper name; separated by semicolons)</b> Fire testing; ionization chamber; light extinction; light scattering; Mie scattering; Rayleigh scattering; smoke measurements.			
<b>18. AVAILABILITY</b> <input checked="" type="checkbox"/> Unlimited  <input type="checkbox"/> For Official Distribution. Do Not Release to NTIS  <input type="checkbox"/> Order From Sup. of Doc., U.S. Government Printing Office Washington, D.C. 20402, SD Cat. No. C13  <input checked="" type="checkbox"/> Order From National Technical Information Service (NTIS) Springfield, Virginia 22151		<b>19. SECURITY CLASS (THIS REPORT)</b>  UNCLASSIFIED	<b>21. NO. OF PAGES</b>
		<b>20. SECURITY CLASS (THIS PAGE)</b>  UNCLASSIFIED	<b>22. Price</b>



