



NBSIR 77-1295

Tests on Insulative Barriers as A Method of Protecting Neoprene Core Mattresses

J. N. Bresse

Center for Fire Research
Institute for Applied Technology
National Bureau of Standards
Washington, D.C. 20234

November 1977

Final Report

Prepared for
**Naval Ship Engineering Center
Naval Sea Systems Command
Department of the Navy
Washington, D.C. 20362**

TESTS ON INSULATIVE BARRIERS AS A METHOD OF PROTECTING NEOPRENE CORE MATTRESSES

J. N. Breese

Center for Fire Research
Institute for Applied Technology
National Bureau of Standards
Washington, D.C. 20234

November 1977

Final Report

Prepared for
Naval Ship Engineering Center
Naval Sea Systems Command
Department of the Navy
Washington, D.C. 20362



U.S. DEPARTMENT OF COMMERCE, Juanita M. Kreps, *Secretary*

Dr. Sidney Harman, *Under Secretary*

Jordan J. Baruch, *Assistant Secretary for Science and Technology*

NATIONAL BUREAU OF STANDARDS, Ernest Ambler, *Acting Director*

CONTENTS

	Page
LIST OF TABLES	iv
LIST OF FIGURES	v
ABSTRACT	1
1. INTRODUCTION	1
2. MATERIALS	2
3. TEST METHODS	2
3.1 Preliminary Ignition Study	2
3.2 Heat Release Rate Calorimeter	2
3.3 Small Scale Compartment Test	3
4. TEST RESULTS	4
4.1 Preliminary Ignition Study	4
4.2 Heat Release Rate Calorimeter	4
4.3 Small Scale Compartment Test	4
4.4 Other Observations	5
5. CONCLUSIONS	6
6. ACKNOWLEDGMENTS.	6
7. REFERENCES	7

LIST OF TABLES

	Page
Table 1. Insulating Materials and Some Physical and Thermal Properties	8
Table 2. Test Results - Heat Release Rate Calorimeter	9
Table 3. Test Results - Small Scale Compartment Timed Observations	10
Table 4. Test Results - Small Scale Compartment Representative of Maximum Compartment and Sample Temperatures	11
Table 5. Test Results - Small Scale Compartment Extreme Gas Concentrations	12

LIST OF FIGURES

	Page
Figure 1. Thermal Conductivity of Insulating Materials	13
Figure 2. Preliminary Ignition Study Apparatus	14
Figure 3. Sample Construction for Heat Release Rate Calorimeter Showing Location of Thermocouple on Surface of Core	15
Figure 4. Front and Plan Views of Small Scale Compartment Showing Location of Samples, Burner Troughs, and Instrumentation	16
Figure 5. Method of Insulating Neoprene Cores with One or Two Layers of Insulation	17
Figure 6. Cutaway Showing Pattern for Insulating Neoprene Cores with More Than Two Layers and Showing Locations of Sample Thermocouples	18
Figure 7. Mattress Sample Holder for Small Scale Compartment	19
Figure 8. Maximum One Minute Average Heat Release Rate versus Insulation Thickness	20
Figure 9. Surface Temperature of Neoprene versus Time from Heat Release Rate Test	21
Figure 10. Maximum Temperatures Developed in the Compartment	22
Figure 11. Time to Reach Maximum Surface Temperature on the Neoprene Specimen in the Compartment versus Thickness of Insulation	23
Figure 12. Exposed Cross Section of Neoprene Core Protected by Six Layers of Insulation	24

TESTS OF INSULATIVE BARRIERS AS A METHOD OF PROTECTING NEOPRENE CORE MATTRESSES

J. N. Breese

Abstract

Tests were performed to determine the value of noncombustible insulative barriers as a method of protecting neoprene (chloroprene) mattress cores from igniting and contributing to a shipboard fire. The mattress systems were tested in the heat release rate calorimeter and in a quarter scale model compartment. Thicknesses of up to 44 mm (1-3/4 in) of ceramic fiber and glass fiber insulation were used to protect the cores. Although the insulation reduced the rate of heating of the core, it also served to raise interior temperatures by the effect of heat "trapping" to a point where the core could continue to decompose and smolder after all exterior heat supply had been removed.

Key words: Compartment fires; fire-retardants; insulation; mattresses; shipboard; thermal conductivity.

1. INTRODUCTION

Comparison tests of neoprene and fire retardant treated polyurethane mattresses, previously performed for the Naval Ship Engineering Center (NAVSEC) by NBS, showed the neoprene to be superior to the polyurethane in a fire situation [1]¹. However, in berthing compartment tests also performed for NAVSEC by NBS it was observed that the neoprene mattress still contributed to the fire when piloted by severe flame impingement or high local thermal exposure [2]. Methods were sought for eliminating or reducing the mattress involvement and NBS was asked by NAVSEC to test the use of noncombustible insulative barrier systems completely surrounding the mattress core as a possible solution.

The following is a discussion of the materials used, testing performed, test results and observations, and conclusions.

2. MATERIALS

Neoprene (chloroprene) mattress cores, cotton ticking covers and insulative barrier materials were provided by the sponsor. The Navy mattress supplied for the tests consisted of a 76-mm (3-in) core of neoprene, density 63.5 kg/m³ (4.0 lb/ft³), covered with a fire-retardant cotton ticking.

¹ Numbers in brackets refer to the literature references listed at the end of this report.

The protected mattress assembly consisted of the neoprene core and the insulative barrier under the fire retardant cotton ticking. The barrier materials consisted of refractory and glass fiber blankets or felts. Table 1 is a summary of the kinds of barrier materials used, their thickness, and associated physical and thermal properties. Figure 1 is a plot of thermal conductivity versus temperature for the different materials. Both table 1 and figure 1 use data provided by the manufacturer. No verification tests were run on the thermophysical properties.

3. TEST METHODS

The testing schedule consisted of preliminary ignition testing, followed by tests in the heat release rate calorimeter, and in a small scale model compartment.

3.1. Preliminary Ignition Study

In the preliminary ignition study, the objective was to find the surface temperature at which flaming combustion was maintained. A 120 x 165-mm (4-3/4 x 6-1/2 in) sample of the neoprene core was exposed to thermal radiation from a 460 x 300-mm (18 x 12-in) gas fired radiant panel. The distance between the sample and the panel could be varied thus varying the irradiance on the sample from 1 to 5 W/cm². The distance was adjusted to the point at which self-sustained flaming of the specimen would just occur in the absence of a pilot flame. A 0.254-mm (0.001 in) diameter chromel-alumel thermocouple was placed on the exposed surface of the sample to monitor the surface temperature at the critical point of ignition. In order to check the dependence of the critical temperature on the thickness of the sample, three different thicknesses, 25, 50 and 75 mm (1, 2, and 3 in), were used. Figure 2 is a picture of the preliminary ignition study apparatus.

3.2. Heat Release Rate Calorimeter

The heat release rate calorimeter was set at an irradiance of 6 W/cm² [3]. The samples were constructed by protecting the 115 x 150 x 25 mm (4-1/2 x 6 x 1 in) neoprene cores on the exposed side by the appropriate thickness of insulation up to 25 mm (1 in). The whole sample was then wrapped in the fire retardant cotton ticking (see figure 3).

In addition to measuring the heat release rate, a thermocouple was placed at the center of the exposed side of the neoprene surface in contact with the insulation in order to monitor the temperature rise of the interface between the core and the insulation (see figure 3).

3.3. Small Scale Compartment Test

The purpose of the small scale compartment test was to observe the performance of the insulative barrier when the mattress system was exposed to an open flame impinging on the mattresses.

The compartment was a quarter-scale model of a 3.1 x 3.1 x 2.4-m (10 x 10 x 8 ft) room made of a noncombustible ceramic fiber board of 25 mm (1 in) thickness and 244 to 288 kg/m³ (15.2 to 18.0 lb/ft³) density. This model was based on the scaling rules developed in the Navy berthing compartment study [2]. The enclosure was intended to provide the radiation feedback from the walls and the ceiling that might occur in an actual compartment fire. Three mattress samples were constructed for each test. They were positioned on sample holders in the right-rear corner of the compartment such that they were spaced 25 mm (1 in) from the back wall, 25 mm (1 in) from the right wall, and also 25 mm (1 in) from each other. This arrangement provides considerable interaction between the mattresses and the walls similar to that which they might have in a tiered bunk fire. The holders supported the samples 75 mm (3 in) above the floor of the compartment and a small alcohol burner trough was positioned under each sample (see figure 4).

The samples were constructed by surrounding a 215 x 215 x 75 mm (8-1/2 x 8-1/2 x 3 in) neoprene core with the insulation and covering the whole sample with fire retardant cotton ticking. Two methods of attaching the insulation to the neoprene core were used. When only one or two layers of insulation were used, the core was wrapped in one or two large blankets and pinned in place while the ticking was being put in place (see figure 5). When more than two layers were used, individual pieces were cut for the top, bottom, sides, and ends and were held in place with straight pins until the ticking could be put in place (see figure 6).

The sample holders were made from 3-mm (1/8-in) dia. steel rod. These rods were welded together into a lightweight frame so that the mattress sample was held securely 75 mm (3 in) above the floor of the compartment. See figure 7 for design and dimensions.

Under each sample holder was placed a 20 x 205-mm (3/4 x 8-in) aluminum foil trough containing 75 ml of 95% methyl alcohol. The flames from the burning alcohol impinged on the mattress through the open grillwork of the sample holder and exposed the samples for nearly 10 minutes.

During the test, CO and O₂ concentrations and the interior and doorway temperatures of the compartment were continuously monitored. In addition, the temperatures on the surface and at the center of the neoprene core of the middle mattress were also monitored. HCN and HCl measurements were taken at 2 minutes, at 4 minutes, at the time the alcohol flame extinguished, and at other selected times.

4. TEST RESULTS

4.1. Preliminary Ignition Study

The minimum temperature required for sustained flaming for the three thicknesses, 25, 50 and 75 mm (1, 2 and 3 in), was generally the same and averaged about 650°C. However, even when the surface temperature was below that at which sustained flaming occurred, the neoprene smoldered, giving off dark smoke and fumes. Note that these results were based on only a few experiments and comparatively rough measurements.

4.2 Heat Release Rate Calorimeter

Table 2 presents a summary of the results from the heat release rate calorimeter tests. The maximum one minute average heat release rate is plotted against the insulation thickness in figure 8. While the thermal properties as well as the thickness of the insulation will have some bearing on the performance, no systematic study of these parameters was carried out for this report. It is evident from the results of the tests that the insulating barrier has the effect of reducing the rate of heat release, i.e. the thicker the barrier, the lower the rate. The maximum one-minute heat release rate was reduced by 50% with a 13-mm refractory fiber insulating layer. At the same time, since the neoprene core underwent a slower, more even heating, the temperature at which the neoprene became involved was lowered with more insulation. While the bare neoprene specimen supported a flame in the preliminary tests when the surface temperature reached 650°C, the specimen covered with the ticking in the calorimeter began to release heat when its surface temperature reached 570°C. As insulation was added the critical temperature was reduced. Figure 9 shows the temperature of the thermocouple on the surface of the neoprene versus time for each sample.

4.3. Small Scale Compartment Test

A summary of test results for the small scale compartment tests are presented in tables 3, 4, and 5. The maximum temperature of the thermocouple on the surface of the neoprene and the maximum air temperature one inch below the ceiling of the compartment are shown as a function of insulation thickness in figure 10. The time to reach the maximum surface thermocouple temperature is shown in figure 11.

The un-insulated samples ignited almost immediately after the alcohol was ignited, and continued to add to the fire for as long as there was direct flame impingement on them and there was still uncombusted fuel available. However, they did not sustain flaming after the alcohol flame died out.

The samples insulated with 1 layer of material "B," 6 mm (1/4 in) thick, took longer before bursting into flame, but the additional interior heat build-up caused by heat trapping precipitated a more severe fire when it finally occurred. The samples also sustained flaming well past the time when the alcohol burned out.

Samples with 1 layer of material "C," 10 mm (3/8 in) thick, burned in generally the same way as the 6 mm samples, stopping, however, just short of flashover. A slightly larger or more severe exposure would probably have caused flashover to occur. In addition the insulation melted and formed a hard shell when cooled.

With 2 layers of material "A" 13 mm (1/2 in) thick, the fire was less severe. After 5 minutes the flames had extended to touch the ceiling of the compartment but soon died back. When the alcohol burned out the samples would not sustain flaming, but the neoprene cores did continue to smolder. Some high temperatures were reached in the core itself and the neoprene was ultimately completely consumed.

Although the samples protected by 4 layers of material "B," 25 mm (1 in) thick, did not exhibit flaming of the neoprene, they did not protect the neoprene cores sufficiently to prevent high inner-core temperatures and their total consumption by smoldering.

Figure 12 is a photograph of the exposed cross section of mattress core taken from the samples with 6 layers of insulation "D." Although this particular mattress system produced the lowest compartment temperatures and the lowest neoprene core temperatures, the insulation allowed an internal heat build-up to the point where the neoprene could be consumed by glowing combustion without any outside heating after the initial exposure by the alcohol flame.

4.4. Other Observations

Six layers was the greatest amount of insulation used. Although substantially more would be required to sufficiently protect the neoprene core, some other characteristics of a mattress protected by six layers of insulation are of interest.

Six layers of 6 mm (1/4 in) insulation nominally provides a 38 mm (1-1/2 in) thickness. The actual thickness in test 6 was 44 mm (1-3/4 in). Since both sides of the 76 mm (3 in) thick neoprene mattress would be insulated, the protected mattress would be nominally 150 mm (6 in) thick, or twice as thick as the unprotected mattress. In addition the protected mattress would be 2-1/4 to 3 times as heavy as the unprotected mattress.²

² The unprotected mattress weighs about 6.4 kg (14 lb) and the insulated mattresses have been calculated to weigh from 14.2 to 20.9 kg (31 to 46 lb).

With six or more layers of insulation, the mattress becomes increasingly rigid, losing much of the natural cushioning of the neoprene.

5. CONCLUSIONS

Neoprene mattress cores protected with several types of noncombustible insulative barriers did not perform significantly better than the unprotected cores except when at least 13 mm (1/2 in) of insulation was used. At that thickness the contribution to the fire was greatly reduced. However, the neoprene was still completely consumed by smoldering. The smoke and toxic products were released at a lower rate but over a much longer time. Greater thicknesses of insulation would be required for protection against more severe fires. Because of the heat trapping, the effect of insufficient insulation thickness is to increase rather than decrease the contribution of the mattress to fire growth in the compartment under the test conditions studied. There did not appear to be any appreciable difference in performance between the refractory fiber and glass fiber insulations used in these tests. When enough insulation is used to prevent the neoprene from becoming involved, the mattress loses much of its resiliency and its size and weight may be prohibitive. Because of the relatively low melting point of the glass fiber insulation, and the high core temperatures reached, the glass fiber insulation tended to soften and fuse; when cooled, a hard, solid shell was formed making it still more difficult to extinguish the glowing mattress cores. Based on the results of the present tests, the use of low density noncombustible insulative barriers does not appear to be a promising method of upgrading the fire performance of the neoprene mattresses.

6. ACKNOWLEDGMENTS

Appreciation is expressed to Mr. Roy Lindauer who constructed the small scale compartment and sample holders.

This project was sponsored by the Naval Sea Systems Command, Department of the Navy, under the direction of Mr. Allan Winer, Technical Agent for the Material and Application Office of the Naval Ship Engineering Center.

7. REFERENCES

- [1] Parker, William J., Comparison of the Fire Performance of Neoprene and Flame Retardant Polyurethane Mattresses, Nat. Bur. Stand. (U.S.), NBSIR 73-177 (April 1973).
- [2] Lee, B.T. and Parker, W.J., Naval Shipboard Fire Risk Criteria - Berthing Compartment Fire Study and Fire Performance Guidelines, Nat. Bur. Stand. (U.S.), NBSIR 76-1052 (September 1976).
- [3] Parker, W.J. and Long, M.E., Development of a Heat Release Rate Calorimeter at NBS, In: Ignition, Heat Release, and Noncombustibility of Materials, ASTM STP 502, American Society of Testing and Materials, (1972) 135-151.

Table 1. Insulating Materials and Some Physical and Thermal Properties

Material	Description	Single Layer Thickness (mm)	Density (kg/m ³)	Specific Heat (J/gK) *	Thermal Conductivity at 260 °C (mW/mK) *	Melting Point (°C)
A	refractory fiber felt	6 (1/4 in)	64	1.1	66	1793*
B	refractory fiber felt	6 (1/4 in)	96	1.1	58	1793*
C	glass fiber blanket	10 (3/8 in)	112	.79	72	---**
D	needled glass fiber blanket	6 (1/4 in)	117	1.1	68	---**

* These values provided by the manufacturers.

** Glass has no definite melting point but softens around 800 °C.

Table 2. Test Results - Heat Release Rate Calorimeter

Insulating Material	Amount of Insulation	Max. 1 min. Avg. Heat Release Rate (W/cm ²)	Max. Sample Surface Thermocouple Temp. (°C)	Time to Involvement of Neoprene (min:s)	Sample Surface TC Temp. at Time of Neoprene Involvement (°C)
None	-----	10.0	776	0:30	570
B	1 Layer (6mm, 1/4 in)	9.5	825	1:42	480
C	1 Layer (10mm, 3/8 in)	7.5	727	4:00	470
A	2 Layers (13mm, 1/2 in)	5.0	740	3:00	470
B	4 Layers (25mm, 1 in)	3.0	538	7:18	440
D	4 Layers (25mm, 1 in)	3.0	544	6:42	435

Table 3. Test Results - Small Scale Compartment
Observation Times

Test	Insulating Material	Thickness of Insulation	Alcohol Flame Out (min:s)	Mattress Flame Out (min:s)	Flashover (min:s)
1	None	---	8:10	8:10	3:05
2	B	1 Layer (6mm, 1/4 in)	8:05	9:50	5:52
3	C	1 Layer (10mm, 3/8 in)	9:15	12:15	--
4	A	2 Layers (18mm, 1/2 in)	9:25	9:25	--
5	B	4 Layers (25mm, 1 in)	9:40	X	--
6	D	6 Layers* (44mm, 1-3/4 in)**	10:18	X	--

* Only 4 layers of insulation were used in the heat release rate calorimeter for this insulating material due to a restriction on sample thickness.

** Although one layer of this insulation is a nominal 6-mm (1/4-in) thick, an actual measurement of the 6 layers of insulation in place was 44 mm (1-3/4 in).

X No flames were observed coming from the samples.

Table 4. Test Results - Small Scale Compartment Representative
Maximum Compartment and Sample Temperatures

Test	Insulating Material	Thickness of Insulation	Maximum Compartment Air Temperature 1" Below Ceiling (°C)	Maximum Neoprene Surface TC Temperature (°C)	Maximum Surface TC Temperature (min:s)
1	None	---	807	872	4:18
2	B	6mm (1/4 in)	813	849	12:36
3	C	10mm (3/8 in)	740	855	15:42
4	A	13mm (1/2 in)	709	898	16:00
5	B	25mm (1 in)	361	910	34:00
6	D	44mm (1-3/4 in)	203	727*	98:24

* The test was stopped at 98:24 so that the neoprene core could be cut open and examined. The maximum sample temperatures reported here are the temperatures at the time the test was stopped. At that time the temperature rise of the sample showed no indication of abating.

Table 5. Test Results - Small Scale Compartment
Extreme Gas Concentrations

Test	Max CO (%)	Time to Max CO (min:s)	Min O ₂ (%)	Time to Min O ₂	Max HCN*		Max HCl*	
					(ppm/min:s)	(ppm/min:s)	(ppm/min:s)	(ppm/min:s)
1	1.0	2:54	15.7	2:48	200/4:00	240/2:00		
2	N.D.**	N.D.	N.D.	N.D.	120/8:00	800/4:00		
3	0.6	10:12	18.4	10:06	200/11:00	300/10:00		
4	0.7	6:30	N.D.	N.D.	80/4:00	500/4:00		
5	0.5	4:00	17.9	4:00	100/4:00	1000/20:00		
6	0.2	0:36	19.0	4:54	0/10:00	0/10:00		

* HCN and HCl were not continuously monitored. The ppm reported here are only the maximum for the readings taken. For all tests the readings were taken at 2 minutes, 4 minutes, and at alcohol flame out. Other readings were taken at the discretion of the operator.

** No data.

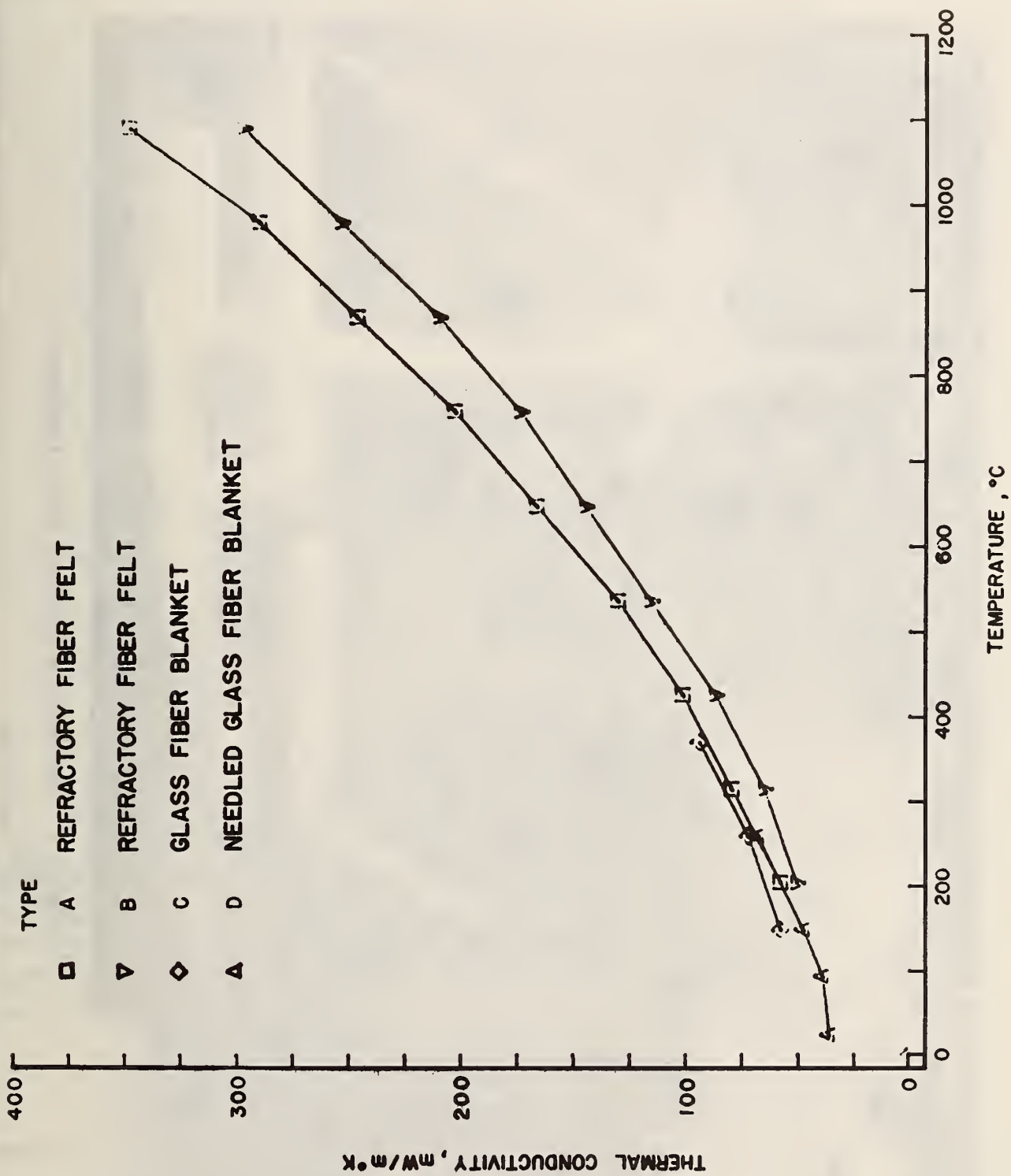

Figure 1. Thermal Conductivity of Insulating Materials

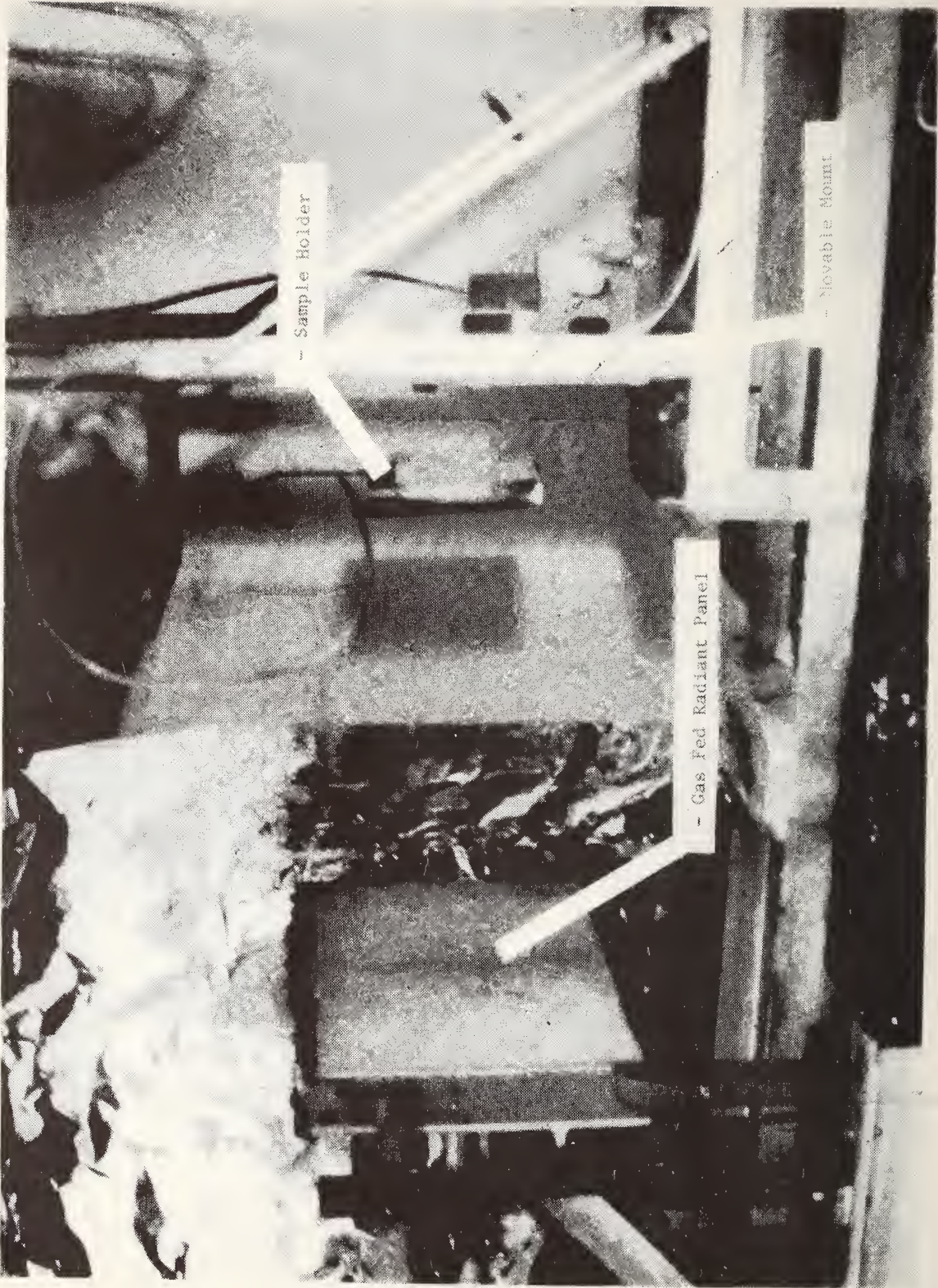
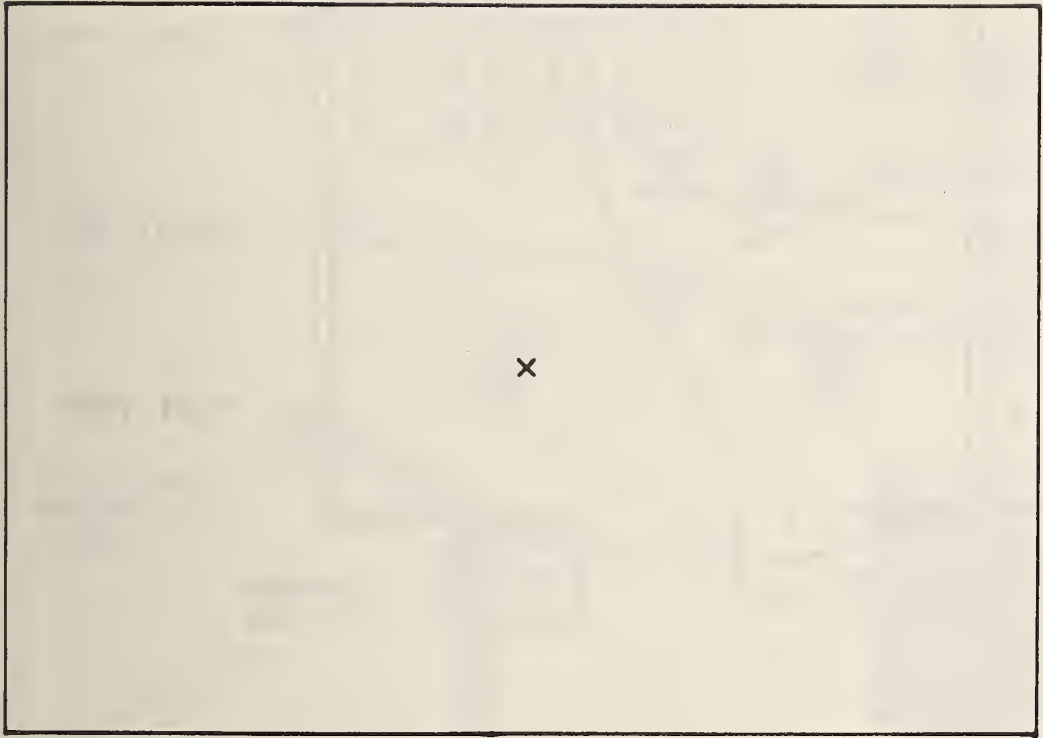
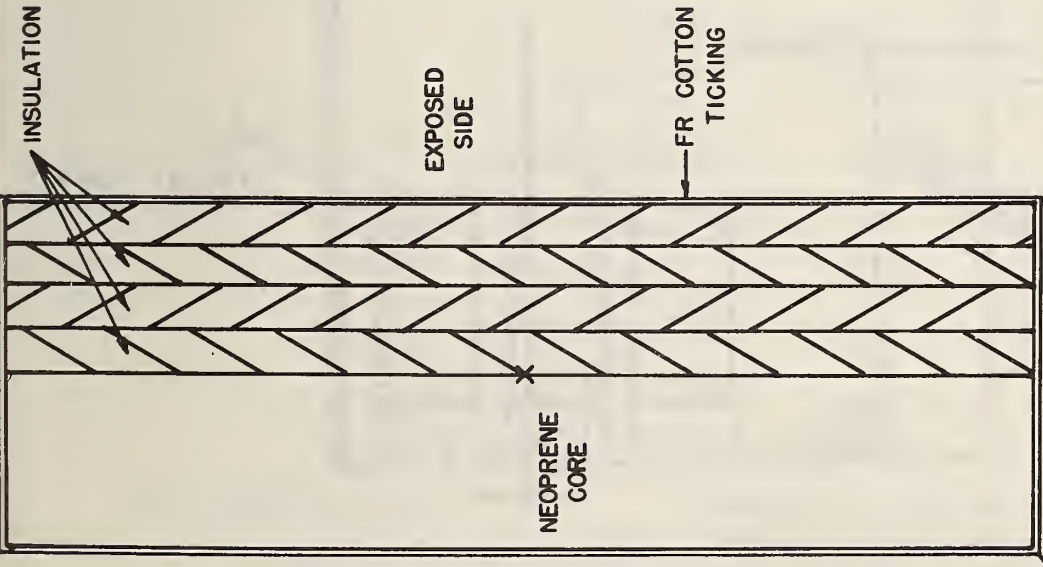

Figure 2. Preliminary Ignition Study Apparatus



FRONT VIEW



SIDE VIEW

X - THERMOCOUPLE BETWEEN CORE AND INSULATION

Figure 3. Sample Construction for Heat Release Rate Calorimeter Showing Location of Thermocouple on Surface of Core

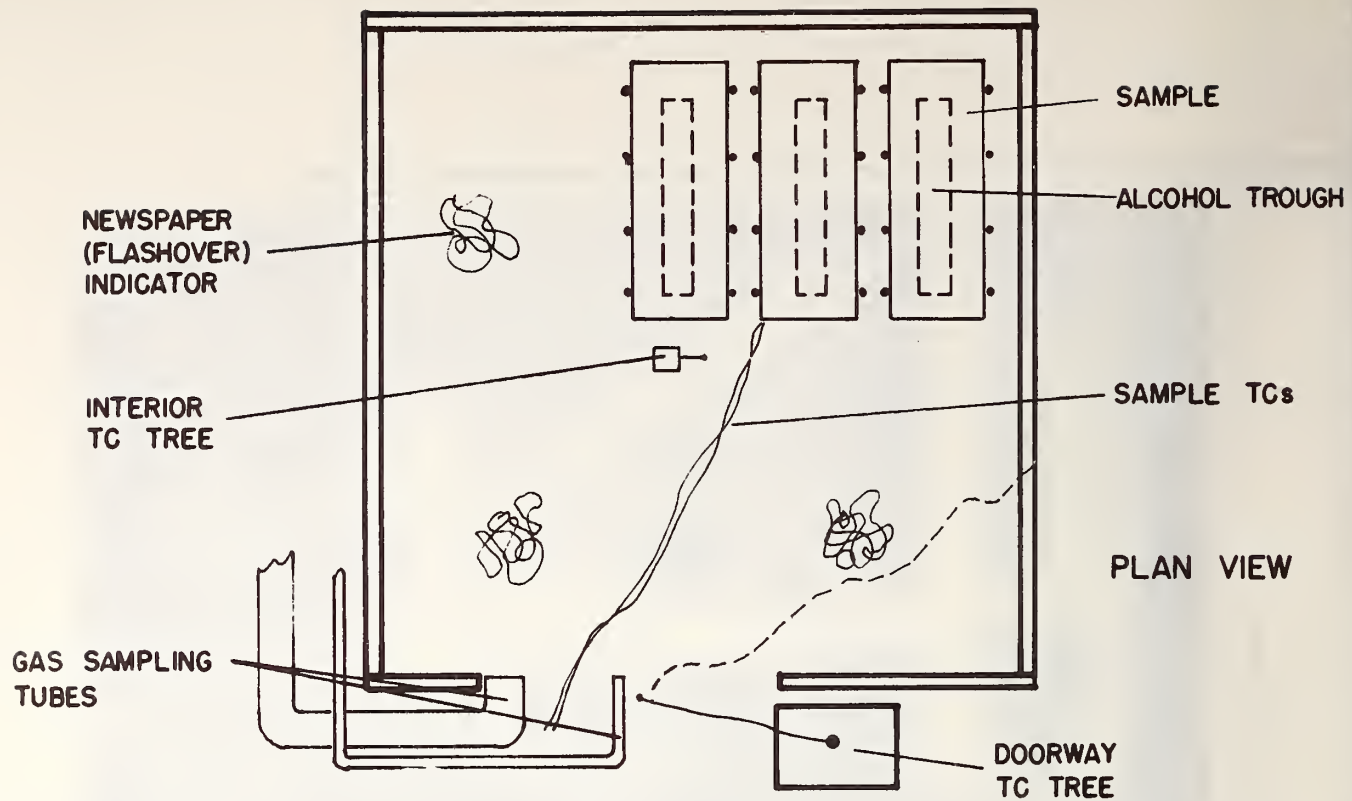
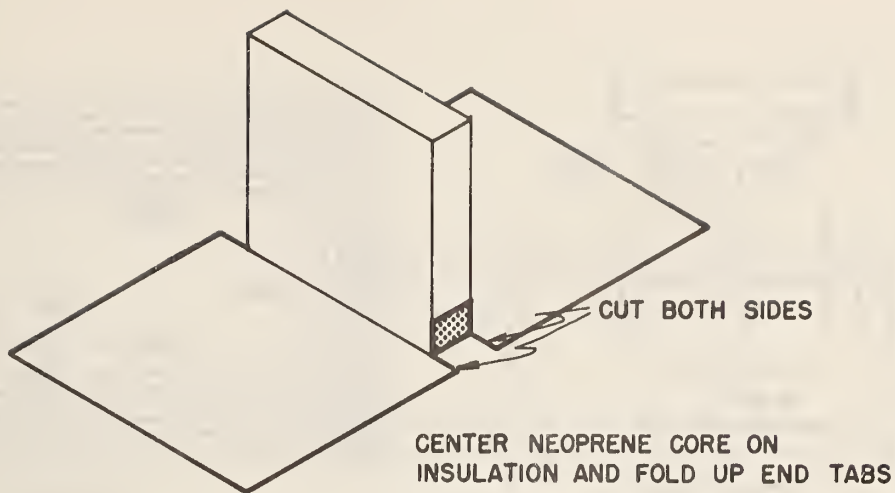
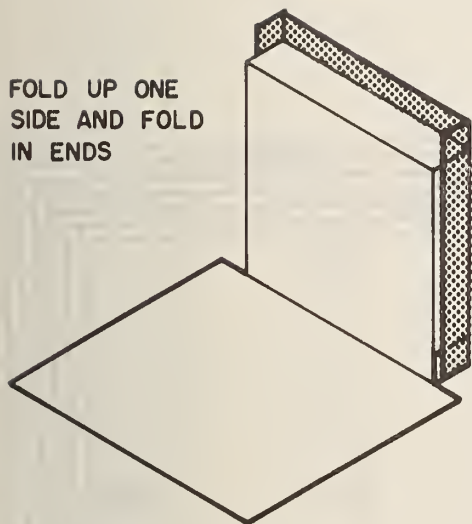

Figure 4. Front and Plan Views of Small Scale Compartment Showing Location of Samples, Alcohol Troughs and Instrumentation



①



②

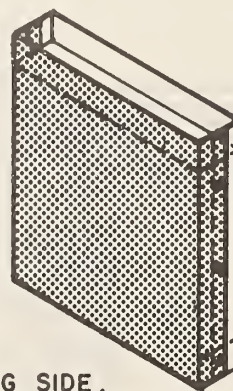

③

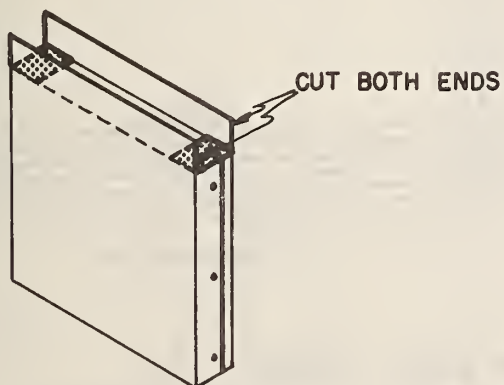

④

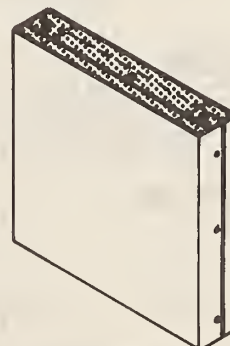

⑤

Figure 5. Method of Insulating Neoprene Cores with One or Two Layers of Insulation

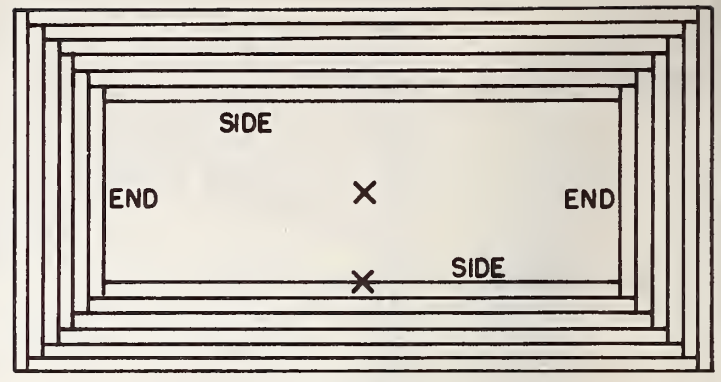
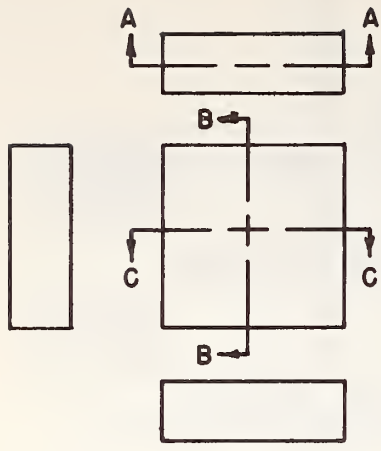

SECTION CC

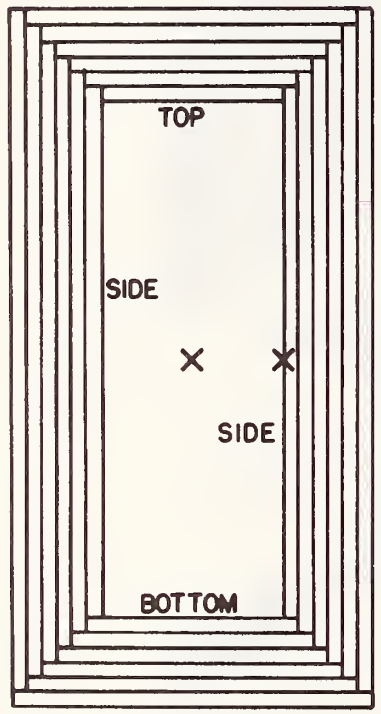

SECTION BB

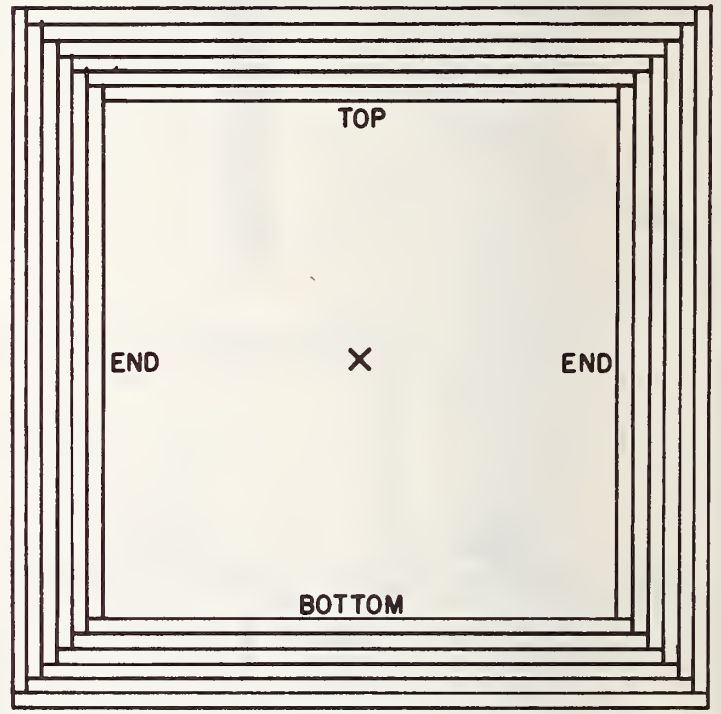

SECTION AA

X - LOCATION OF SAMPLE INTERNAL TCs

Figure 6. Cutaway Showing Pattern for Insulating Neoprene Cores with More Than Two Layers and Showing Locations of Sample Thermocouples

3 mm STEEL ROD
WELDED AT ALL JOINTS

TOP VIEW

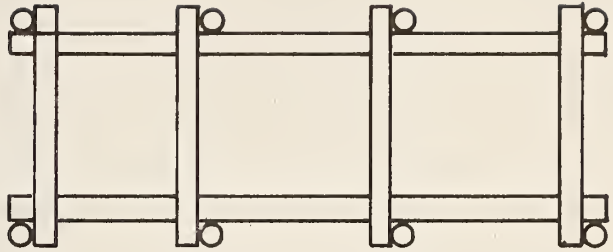

END VIEW

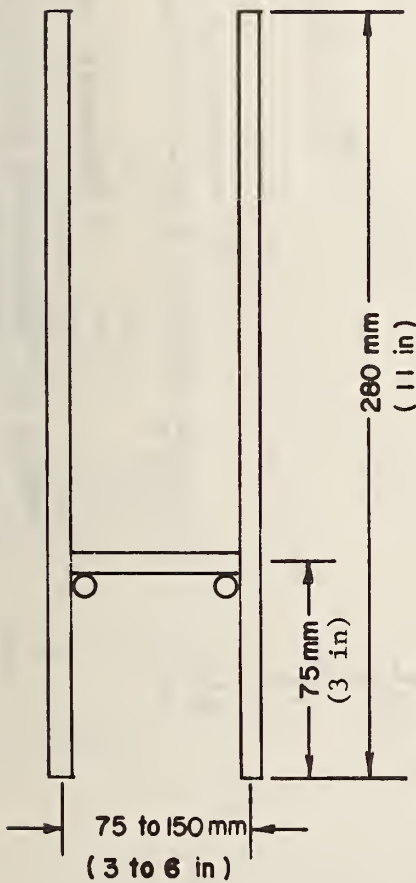

SIDE VIEW



Figure 7. Mattress Sample Holder for Small Scale Compartment

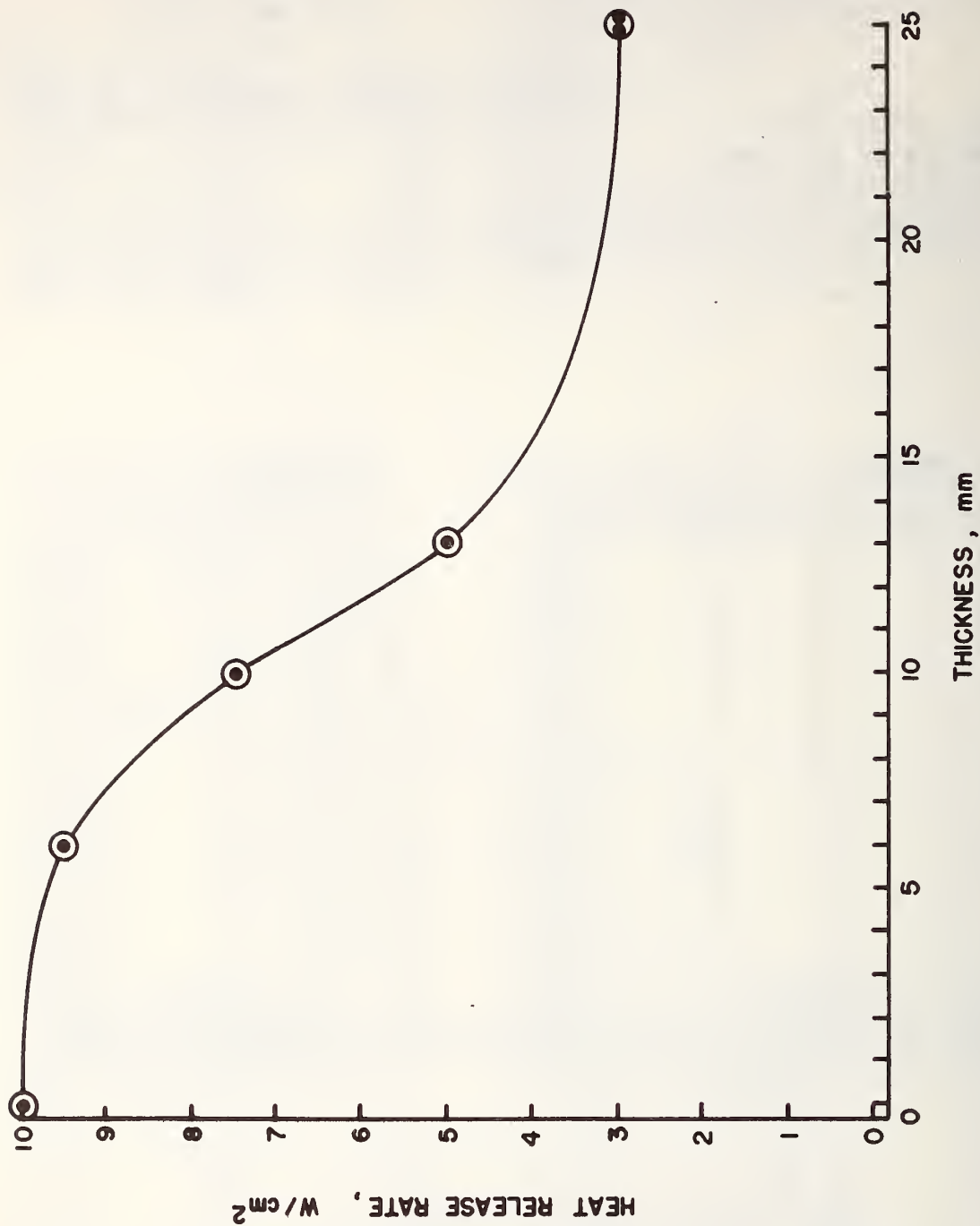

Figure 8. Maximum One Minute Average Heat Release Rate versus Insulation Thickness

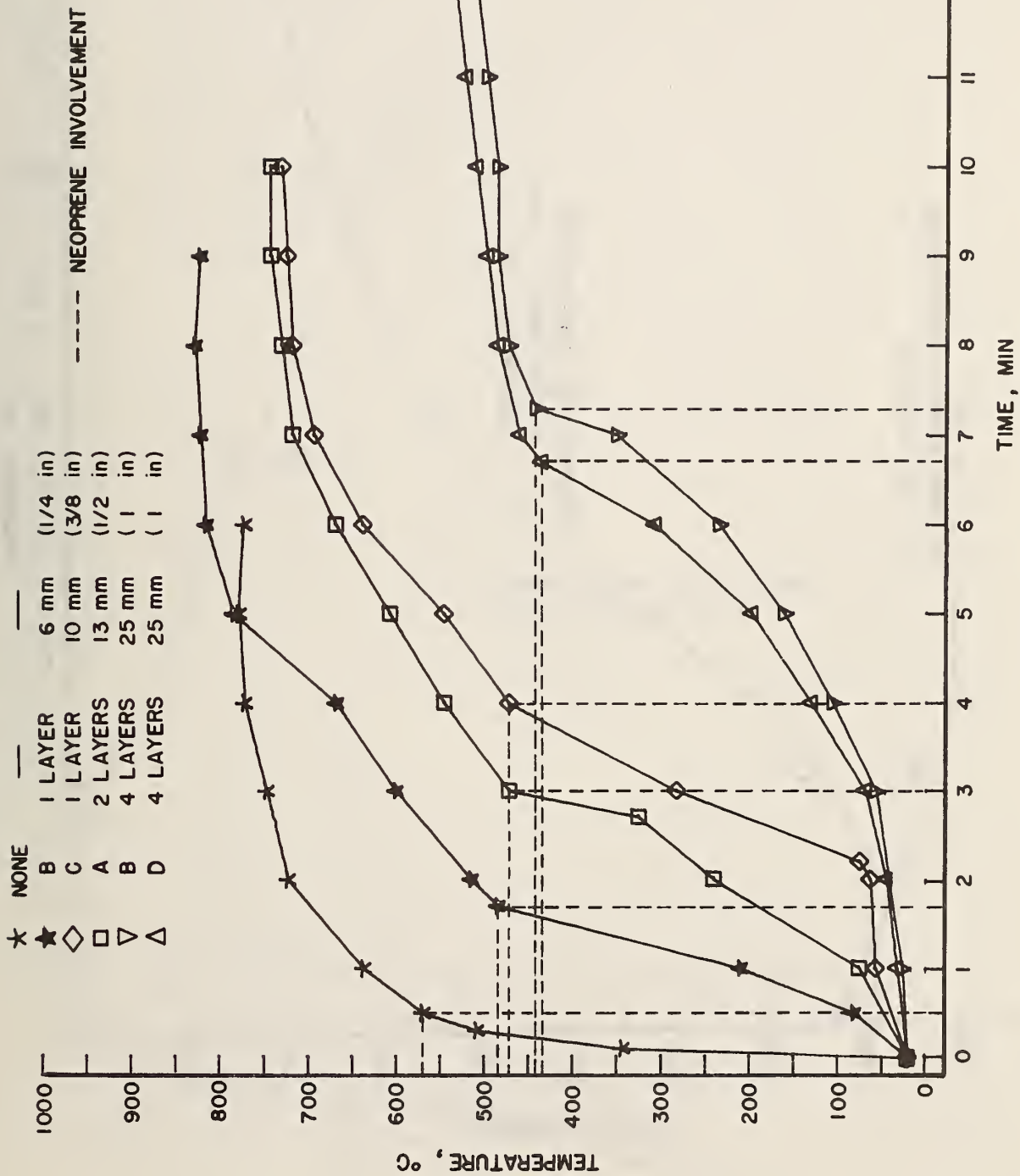

Figure 9. Surface Temperature of Neoprene versus Time from Heat Release Rate Test

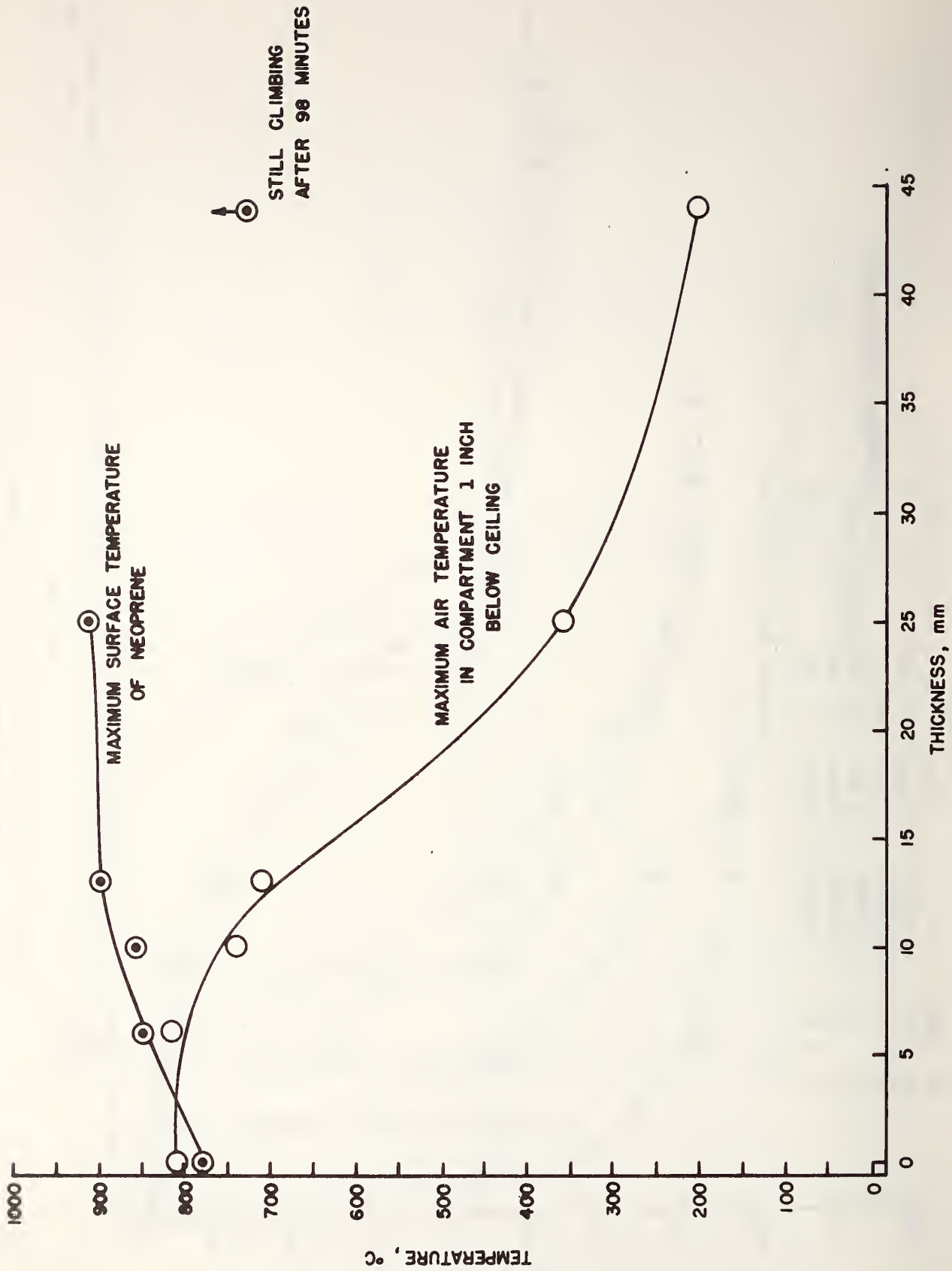

Figure 10. Maximum Temperatures Developed in the Compartment

↑
○
(44, 98.4)*

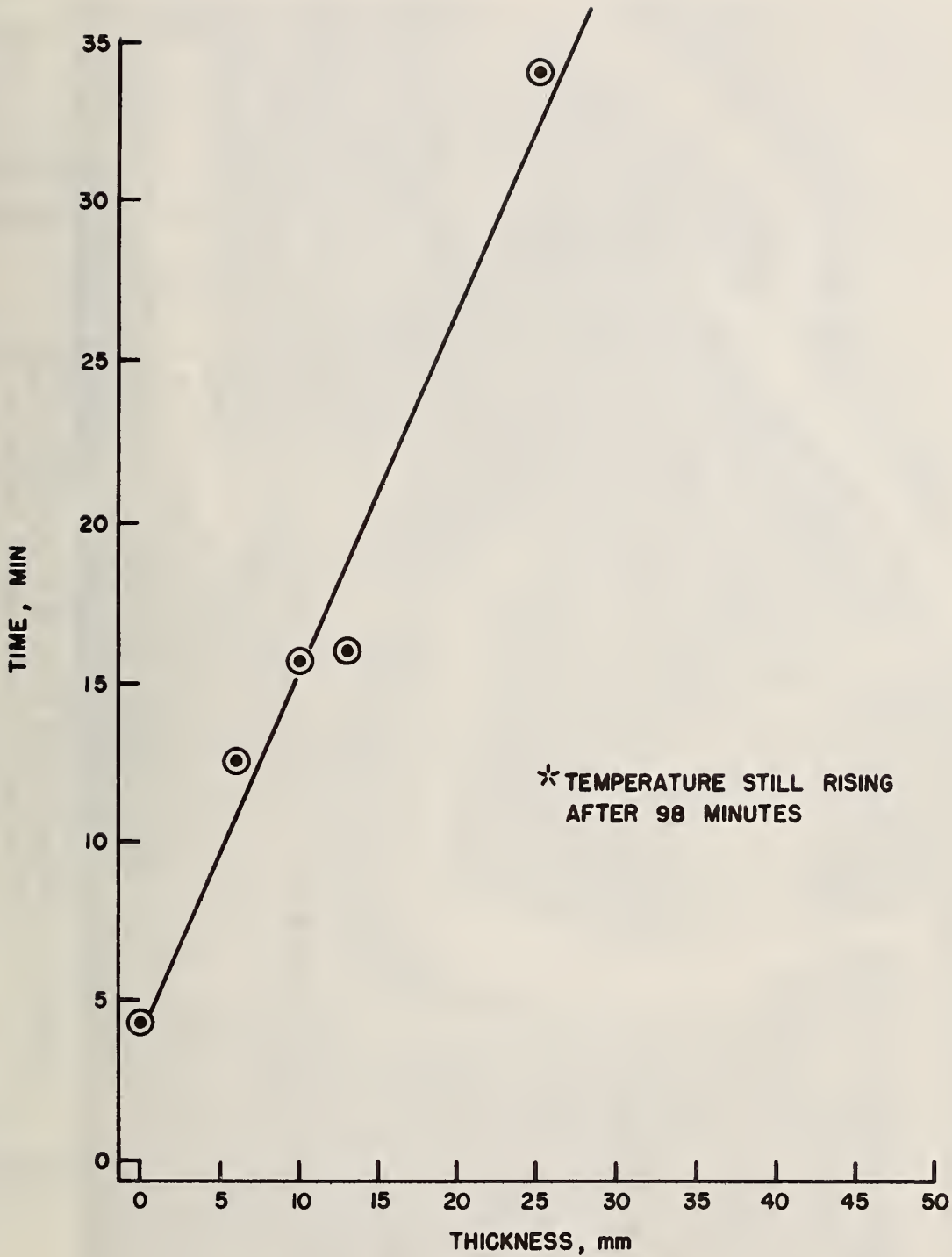

Figure 11. Time to Reach Maximum Surface Temperature on the Neoprene Specimen in the Compartment versus Thickness of Insulation

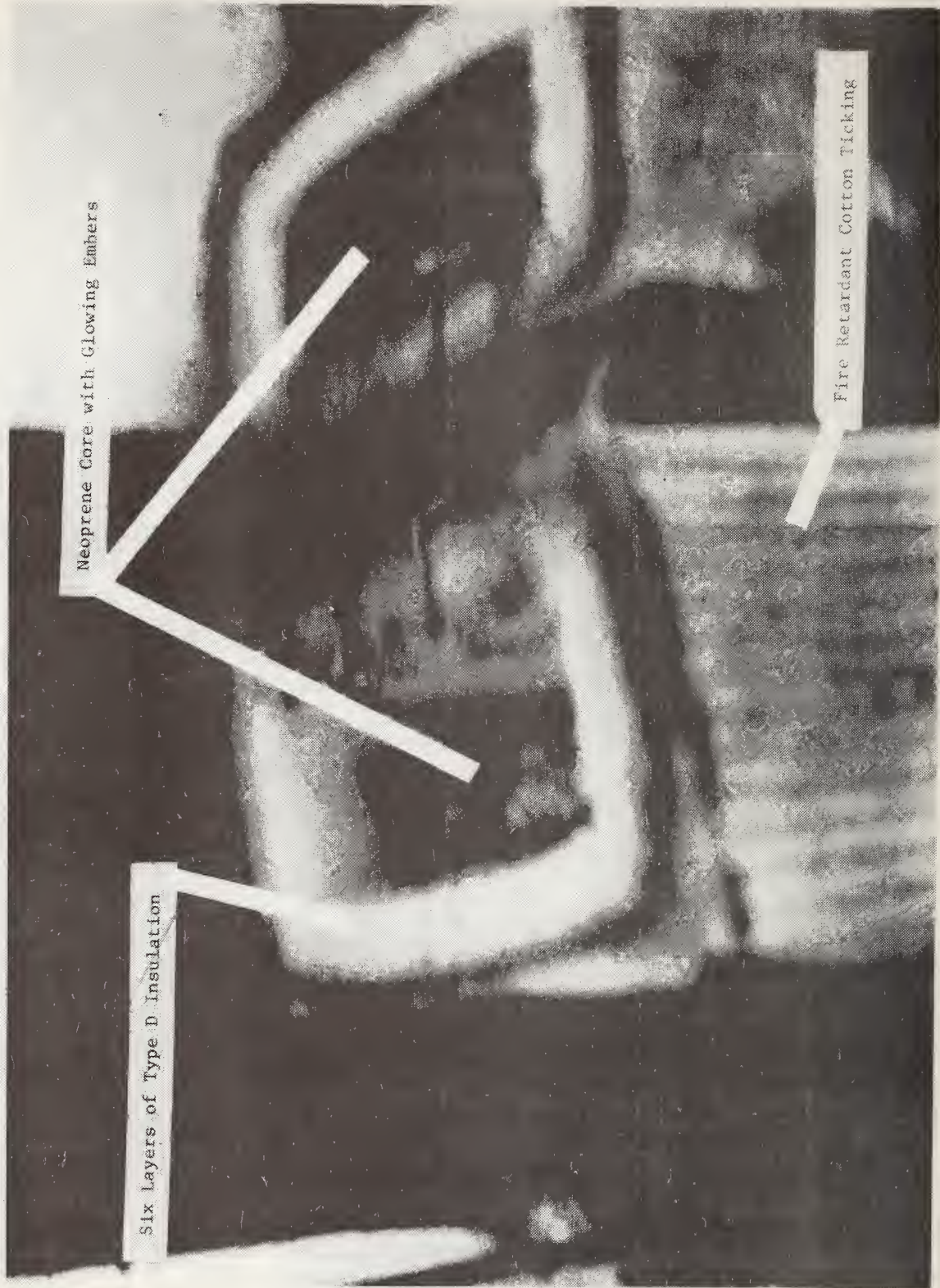

Figure 12. Exposed Cross Section of Neoprene Core Protected by Six Layers of Insulation

U.S. DEPT. OF COMM. BIBLIOGRAPHIC DATA SHEET	1. PUBLICATION OR REPORT NO. NBSIR 77-1295	2. Gov't Accession No.	3. Recipient's Accession No.
4. TITLE AND SUBTITLE Tests on Insulative Barriers as a Method of Protecting Neoprene Core Mattresses		5. Publication Date November 1977	
		6. Performing Organization Code	
7. AUTHOR(S) J. N. Breese		8. Performing Organ. Report No.	
9. PERFORMING ORGANIZATION NAME AND ADDRESS NATIONAL BUREAU OF STANDARDS DEPARTMENT OF COMMERCE WASHINGTON, D.C. 20234		10. Project/Task/Work Unit No. 4926387	
		11. Contract/Grant No.	
12. Sponsoring Organization Name and Complete Address (Street, City, State, ZIP) Naval Ship Engineering Center Naval Sea Systems Command Department of the Navy Washington, D.C. 20362		13. Type of Report & Period Covered Final Report	
		14. Sponsoring Agency Code	
15. SUPPLEMENTARY NOTES			
<p>16. ABSTRACT (A 200-word or less factual summary of most significant information. If document includes a significant bibliography or literature survey, mention it here.)</p> <p>Tests were performed to determine the value of noncombustible insulative barriers as a method of protecting neoprene (chloroprene) mattress cores from igniting and contributing to a shipboard fire. The mattress systems were tested in the heat release rate calorimeter and in a quarter scale model compartment. Thicknesses of up to 44 mm (1-3/4 in) of ceramic fiber and glass fiber insulation were used to protect the cores. Although the insulation reduced the rate of heating of the core, it also served to raise interior temperatures by the effect of heat "trapping" to a point where the core could continue to decompose and smolder after all exterior heat supply had been removed.</p>			
<p>17. KEY WORDS (six to twelve entries; alphabetical order; capitalize only the first letter of the first key word unless a proper name; separated by semicolons) Compartment fires; fire-retardants; insulation; mattresses; shipboard; thermal conductivity.</p>			
<p>18. AVAILABILITY <input checked="" type="checkbox"/> Unlimited</p> <p><input type="checkbox"/> For Official Distribution. Do Not Release to NTIS</p> <p><input type="checkbox"/> Order From Sup. of Doc., U.S. Government Printing Office Washington, D.C. 20402, SD Cat. No. C13</p> <p><input checked="" type="checkbox"/> Order From National Technical Information Service (NTIS) Springfield, Virginia 22151</p>		<p>19. SECURITY CLASS (THIS REPORT)</p> <p>UNCLASSIFIED</p>	<p>21. NO. OF PAGES</p> <p>29</p>
<p>20. SECURITY CLASS (THIS PAGE)</p> <p>UNCLASSIFIED</p>		<p>22. Price</p> <p>\$4.50</p>	

