

**NBSIR 76-979**

# **Intercomparison Procedures for Gage Blocks Using Electromechanical Comparators**

---

J. S. Beers  
C. D. Tucker

Institute for Basic Standards  
National Bureau of Standards  
Washington, D. C. 20234

January 1976

Final

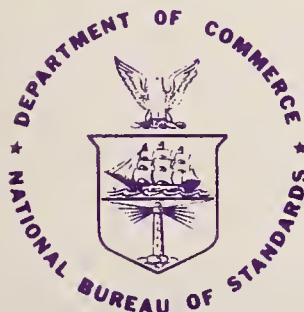

---

**U S. DEPARTMENT OF COMMERCE  
NATIONAL BUREAU OF STANDARDS**



NBSIR 76-979

**INTERCOMPARISON PROCEDURES  
FOR GAGE BLOCKS USING  
ELECTROMECHANICAL COMPARATORS**

J. S. Beers  
C. D. Tucker

Institute for Basic Standards  
National Bureau of Standards  
Washington, D. C. 20234

January 1976

Final

**U.S. DEPARTMENT OF COMMERCE, Rogers C.B. Morton, *Secretary***  
**James A. Baker, III, *Under Secretary***  
**Dr. Betsy Ancker-Johnson, *Assistant Secretary for Science and Technology***  
**NATIONAL BUREAU OF STANDARDS, Ernest Ambler, *Acting Director***



## CONTENTS

	Page
A. Introduction	1
B. The Comparator	1
C. Environment	3
D. Gage Block Requirements	3
E. Temperature Effects and Their Control	4
F. Intercomparison Procedure	5
1. Block Preparation	5
2. Comparator Preparation	5
3. Block Storage	5
4. Thermal Equalization Time	6
5. Temperature Measurement	6
6. Handling Techniques	7
7. Observations	9
8. Temperature and Deformation Corrections	9
G. Computation and Analysis	9
H. Summary	12
References	13
Appendix: Experimental Evidence of Thermal Effects in Long Gage Blocks	14



INTERCOMPARISON PROCEDURES FOR GAGE BLOCKS  
USING ELECTROMECHANICAL COMPARATORS

by

J. S. Beers and C. D. Tucker

A. Introduction

The techniques described here for intercomparing gage blocks with electro-mechanical gage block comparators are the results of considerable experimental work, statistical design and process analysis. Some laboratories will find these techniques ideally suited to their needs while others may wish to modify them, but in either event the Measurement Assurance Program (MAP) described here, in part, and in other papers [1, 2, 3, 7]\* will promote the analysis of measurement requirements and the application of statistical principles.

Length values are assigned to unknown gage blocks by a transfer process from blocks of known length. Briefly, the transfer process is a systematized intercomparison of 4 blocks of the same nominal size, called a "4-1" series, using an electro-mechanical comparator. Two of the blocks are unknowns and two are standards. Such a process is ideally suited to comparing objects with nearly identical characteristics such as gage blocks and the process provides the redundancy needed for statistical analysis. Derived corrections can be applied where such characteristics as coefficient of thermal expansion and resistance to mechanical deformation differ [4]. The method applies to all sizes but special precautions will be described for long gage blocks where temperature effects predominate.

B. The Comparator

There are a number of suitable comparator designs and a typical one is shown schematically in figure 1. An upper stylus and a lower stylus contact the gaging faces of a block supported on an anvil. Each stylus is attached to a differential transformer core. An integrated signal from these two transducers is displayed on a meter graduated in length units (usually microinches). The difference in length between two gage blocks is obtained by inserting the blocks, one at a time, between the stylus tips and taking the difference between the two readings.

---

\*Figures in brackets indicate the literature references at the end of this paper.

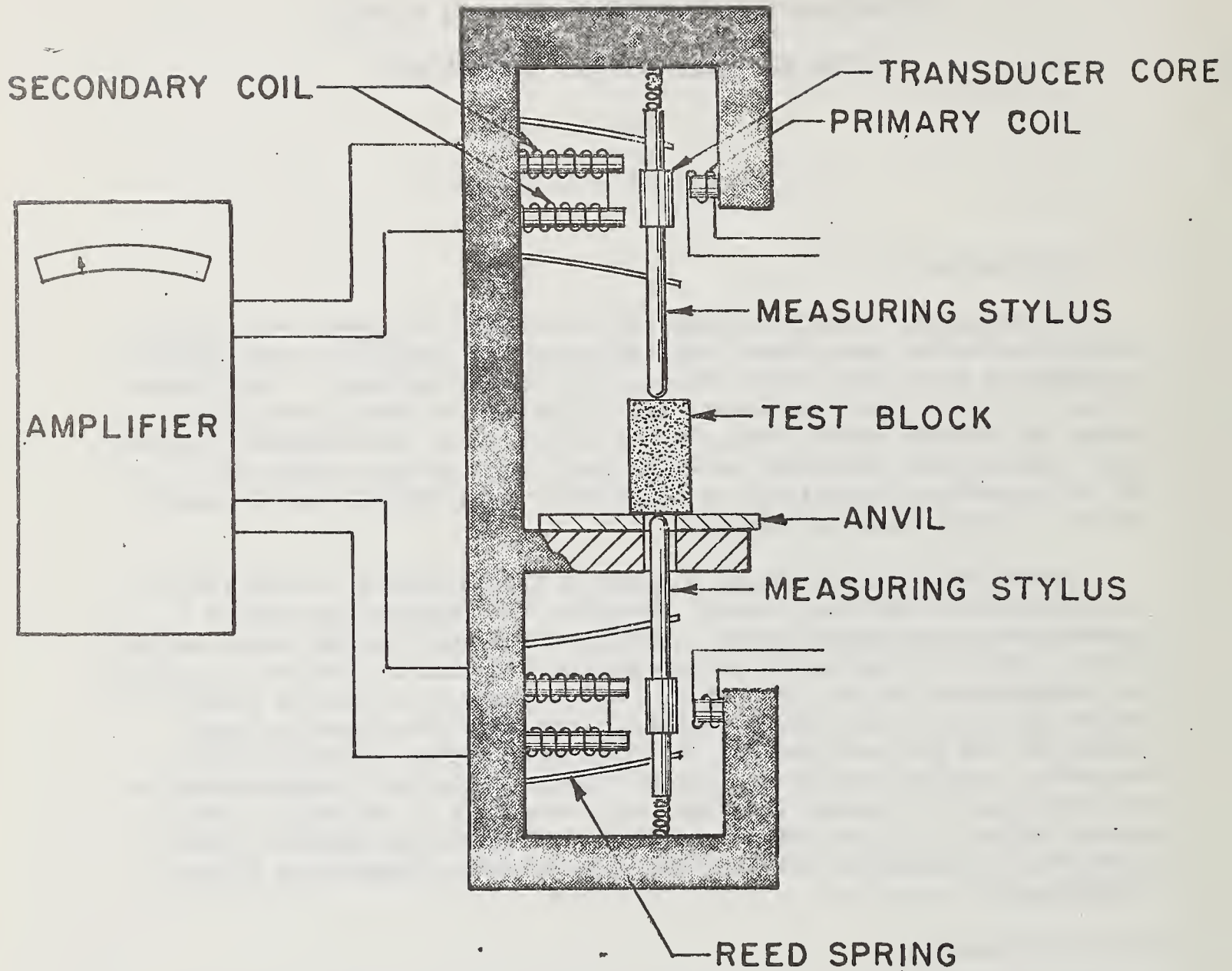

ELEMENTS OF A MECHANICAL  
COMPARATOR OF LENGTHS.

FIGURE 1.



An important comparator feature is the point to point measurement along an axis through the gaging point of the block. Other suitable comparator designs use only one transducer but by various means insure the point to point measurement.

For the most precise measurements, it is important that the defined gage point of the blocks be contacted by the comparator stylus. A metal or plastic bar about 1/4 inch thick is fastened to the anvil (with laboratory wax if no other means is provided) behind the stylus and is positioned to stop the gage blocks so the stylus will contact the gage point. The bar can be L-shaped to position the gage block both laterally and transversely if desired and special configurations can be devised for comparing blocks of different shapes.

### C. Environment

A temperature controlled laboratory is necessary for intercomparisons of the highest precision. The degree of temperature control needed depends on the length of the blocks being compared, differences in coefficients of thermal expansion among the blocks, and the limiting uncertainty required for the unknown blocks. At NBS, blocks in the size range up to 4 inches are intercompared in a temperature controlled laboratory at  $20^{\circ} \pm .25^{\circ}$  Celsius. Blocks longer than 4 inches are intercompared in a laboratory at  $20^{\circ} \pm .05^{\circ}$  Celsius. Relative humidity is held below 50% to prevent corrosion of blocks and instruments.

### D. Gage Block Requirements

Nearly all gage blocks are either square or rectangular in cross section, but a few have a circular cross section. Any of these cross sections are easily handled in intercomparison procedures in sizes up to 4 inches. From 5 to 20 inches, however, the rectangular cross section becomes prone to tipping.

Transferring the length unit to a gage block by intercomparison does not require rigorous constraints on the flatness and parallelism of its gaging faces because the transfer is made only along a single line through the block. Gage block use, however, may be more demanding on the geometry of the gaging faces. A separate paper covers the measurement of flatness and parallelism [6].

Thermal expansion coefficients are generally taken from bulk values and these may vary by as much as 10% from actual values for gage blocks. This problem can be circumvented in the intercomparison process by insuring that blocks being intercompared are as close as possible to  $20^{\circ}$  Celsius.

If non-standard temperatures are used, the coefficients must be known unless the attendant systematic errors are tolerable.

#### E. Temperature Effects and Their Control

A large uncertainty in the comparison process can be introduced by temperature effects. For example, a temperature difference of  $.5^{\circ}\text{Celsius}$  between two one-inch steel blocks will cause an error of nearly 6 micro-inches in the comparison. Two causes of temperature differences between blocks are noteworthy:

(1) room temperature gradients or nearby heat sources such as electronic equipment can cause significant temperature differences between blocks even when they are stored relatively close to each other before comparison and

(2) blocks with different surface finishes on their non-gaging faces can absorb radiant heat at different rates and reach different equilibrium temperatures. The magnitude of these effects is proportional to gage block length. See the appendix at the end of this paper for further discussion of this subject.

A number of remedies have been developed. For short blocks (through 4 inches) the remedies are quite simple. For example, storing the blocks, both standards and unknowns, on a thermal equalization plate of smooth surface and good heat conductivity close to the comparator but away from heat sources. Also, the use of tweezers or tongs to handle the blocks and a systematic, rhythmic block handling technique in the comparison procedure to insure identical thermal environment for each block.

Precautions for long blocks (over 4 inches) are more elaborate. At NBS the comparator is enclosed in an insulated housing partially open on the front to allow handling of the blocks with tongs. Blocks are stored on the comparator anvil and each block is wrapped in 3 layers of Mylar\* reflective film to equalize their thermal characteristics. The laboratory lights remain off except for one lamp well removed from the comparator but giving enough illumination to work by. Heat sources are kept as far away from the comparator as possible and the comparator is located away from other activities where laboratory personnel might congregate. As a further precaution during intercomparisons the operator wears a cape of Mylar reflective film and heavy cotton gloves while handling the blocks with tongs. Finally, as with short blocks, the handling procedure is systematic, rhythmic and quick but not rushed.

---

\*Certain commercial equipment, instruments, or materials are identified in this paper in order to adequately specify the experimental procedure. In no case does such identification imply recommendation or endorsement by the National Bureau of Standards, nor does it imply that the material or equipment identified is necessarily the best available for the purpose.

Temperature problems can be detected in long block intercomparisons by reversing the storage positions of the 4 blocks and repeating the intercomparison after suitable equalization time. Temperature gradients in the storage area will be revealed by a significant change in the differences between blocks. Still another method is to measure the temperature of each block with a thermocouple. A temperature measuring system is described in reference [7]. Where gradients are not a problem, a mercury-in-glass thermometer mounted on the comparator will be adequate.

## F. Intercomparison Procedure

### 1. Block Preparation

The master and test blocks must be thoroughly cleaned, examined, and deburred using procedures in reference [5]. The identification numbers are recorded for inclusion in the test report or records.

Gage blocks longer than 4 inches are wrapped in three layers of Mylar reflective film (available as BSA Rescue Blanket Stock No. 1090) with the reference edge and identity of the block marked on the outside of the wrapping.

### 2. Comparator Preparation

The instrument anvil should be deburred and cleaned. The comparator transducer pressure, magnification and alignment should be checked [5]. Periodic cleaning of the instrument anvil is recommended during the work day to help reduce the number of spurious readings that result from minute particles that can contaminate the anvil surface.

It is necessary, when making preparations to intercompare long gage blocks, that after adjusting the comparator for accepting a particular size gage block that all four blocks in that series be inserted between the probes to insure that all readings will be on scale at that magnification when the intercomparison run is made.

### 3. Block Storage

Short blocks, up to 4 inches in length, are arranged in groups of 4 (2 standards and 2 unknowns) of the same nominal size on a thermal equalization plate next to the comparator. From here they can be moved to the comparator anvil by groups at the time of comparison. There is some thermal advantage for sizes from about 0.3 inch to

4 inches to leaving the blocks on the plate at all times except when the block is being inserted in the comparator for measurement. Alternatively, a group can be moved to the comparator anvil and allowed to equalize there for an appropriate period (see section F4).

The four long gage blocks in a group are stored on the comparator anvil after preparation. Additional long blocks that are to be measured during the day are prepared and placed on a thermal equalization plate next to the instrument. As comparisons of one group of 4 are completed a new size group can be moved from the plate to the anvil and allowed to equalize before comparison. All gage blocks are oriented on the comparator with the top surface uppermost.

#### 4. Thermal Equalization Time

Equalization time varies with block size, treatment and allowable measurement uncertainty. Blocks prepared in advance and kept in the gaging area are placed on the equalization plate, or in the case of long blocks, moved from the equalization plate to the comparator anvil. They may then be intercompared using the following table as a first approximation:

<u>Block Size</u> (inches)	<u>Equalization Time</u> (minutes)
0.1 to 0.250	30
0.300 to 1.000	60
2.000 to 20.000	90

Experiments establishing optimum equalization times should be conducted in your own laboratory because of the many variables involved and differing measurement uncertainty requirements.

#### 5. Temperature Measurement

Temperature measurements are made with a calibrated mercury-in-glass thermometer. The thermometer is mounted on the block storage plate in the case of short blocks and on the instrument anvil for the long blocks. Apply the test described in the last paragraph of Section E to reveal significant temperature differences among the blocks.

In cases where thermocouple measurement of temperature in long

blocks is necessary because of incurable gradients or exceptionally high accuracy requirements, the thermocouple leads should be attached to the instrument column to preclude their interfering with vital parts of the comparator but with enough slack to permit the blocks to be moved on the anvil. The leads are labeled before insertion into the blocks. The thermocouple is inserted halfway down the hole in the block and the hole is plugged at each end with a small piece of polyurethane. A rubber band placed about one-half inch below the top of the block keeps the thermocouple wire in place. Be sure the thermocouple junctions are insulated electrically from the block. Transparent mending tape is sufficient insulation.

## 6. Handling Techniques

The comparison sequence is described in Section F7 but the success of this "4-1" intercomparison is largely dependent upon block handling techniques. These techniques include the insertion of all blocks between the styli in a like manner. The operator should develop a rhythm, after he acquires some experience with the process, that will ensure that each pair of blocks is handled for approximately the same length of time as all other pairs in the series. The time interval to make the sixteen observations should be approximately 2 to 4 minutes for an experienced operator with automatic data recording or an assistant doing the recording.

A camel's hair brush or an air bulb is useful for sweeping or blowing dust particles from the blocks and the anvil just before insertion.

The short blocks are moved about by grasping them with rubber tipped 10-inch tweezers. When handling square style blocks, the tips of a pair of tweezers may be bent to accommodate this configuration.

Gloves may be worn in addition to using tweezers when handling blocks from 0.400 inch through 4 inches. The blocks above the 4-inch size are preferably intercompared on a different instrument situated in a more precisely controlled temperature environment and the operator may wear a Mylar reflective cape as well as gloves.

A special pair of tongs can be made to facilitate handling (see fig. 2) when sliding long blocks (5 to 20 inches) about the an-

RUBBER DIP  $\frac{1}{16}$  APPROX

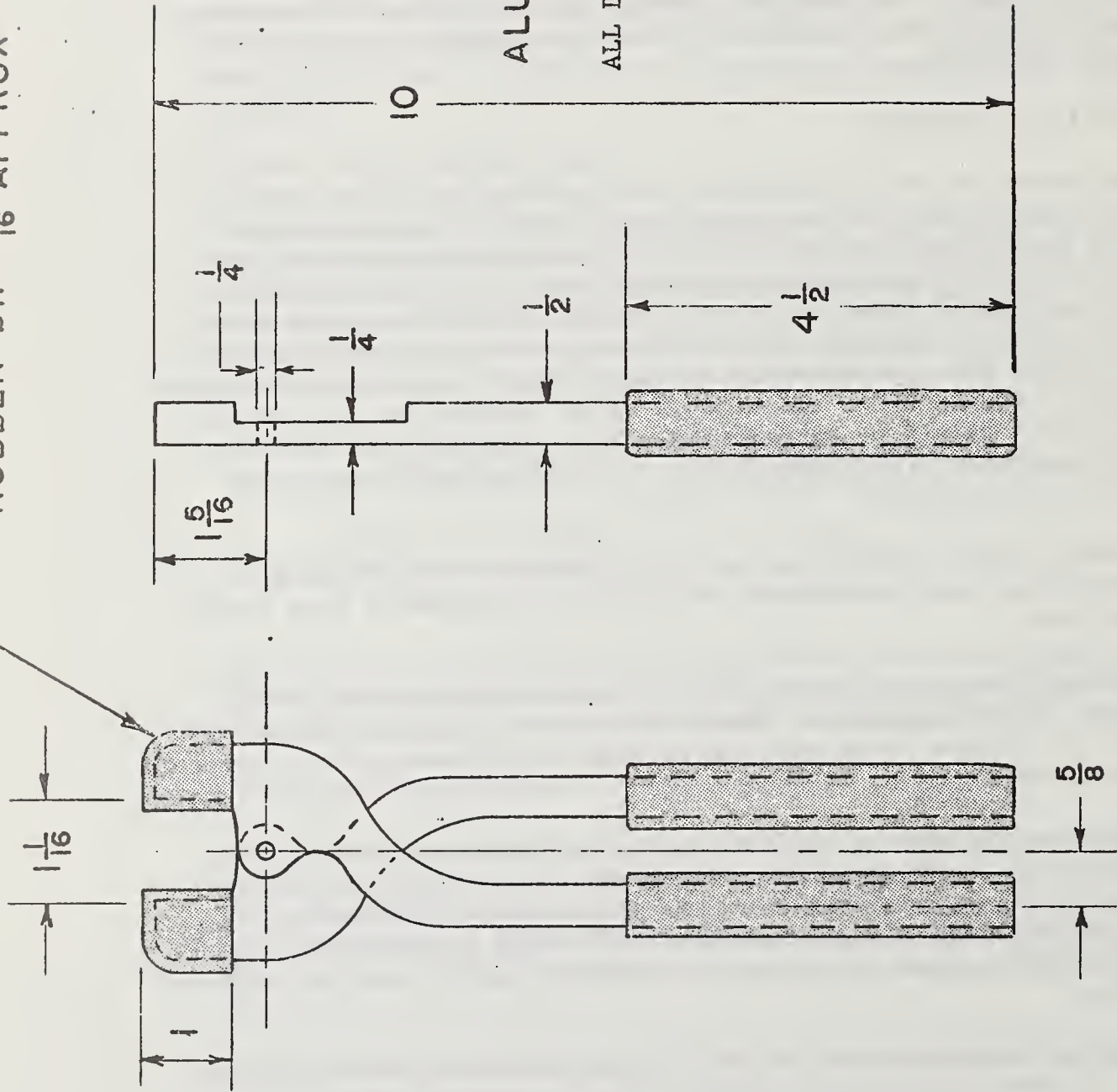

ALUMINUM ALLOY

ALL DIMENSIONS IN INCHES

HOKE BLOCK TONGS

FIGURE 2

vil and between the measuring probes. With these tongs, long blocks should be grasped about one-half inch above the bottom to effect the surest, safest method of moving the blocks.

The anvil stop plays an important part in the seating of the probe on the block surface as well as the positioning of the gage point between the probes. The block is moved tangentially toward the stop allowing one corner to touch the stop and then with an angular motion (which seats the probe on the block surface) proceed to abut the entire edge of the block to the stop.

## 7. Observations

The sequence of observations is from a design series developed to compensate instrument and temperature drifts [3]. The series of readings for each size utilizes two calibrated master blocks,  $S_1$  and  $S_2$ , and two unknown blocks, X and Y. The order of observations is as follows:

$$\begin{array}{ll} A_1 = S_1 - S_2 & A_5 = S_2 - Y \\ A_2 = Y - S_1 & A_6 = Y - S_1 \\ A_3 = X - Y & A_7 = S_1 - X \\ A_4 = S_2 - X & A_8 = X - S_2 \end{array}$$

## 8. Temperature and Deformation Corrections

Deformation corrections for various stylus radii and pressures [4], can be applied to the observations when comparing blocks of different materials if the correction is of sufficient magnitude to be significant.

Temperature corrections are applied to all blocks above 0.350 inch in size when the blocks are of different materials. This size limit can be raised if larger uncertainties are acceptable.

## G. Computation and Analysis

A computer program and discussion of data processing is in reference 3. Figures 3 and 4 show the file format, input and output.

## PRELMY FILE FORMAT

SAME AS PRELMX FILE FORMAT, BUT NOMINAL SIZES MUST AGREE LINE FOR LINE

### REPORT FILE FORMAT (OUTPUT FOR 1108)

LINE 0010 DATE OF OBSERVATIONS  
LINE 0020 TWO INITIALS OF OBSERVER  
LINE 0030 INSTRUMENT USED, FEDERAL #1 OR FEDERAL #2

LINE 0040 TEST NUMBER FOR "X" SET OF GAGE BLOCKS  
LINE 0050 SUBMITTED BY "X" CUSTOMER  
LINE 0060 ADDRESS OF "X"  
LINE 0070 ADDRESS OF "X"  
LINE 0080 SERIAL NUMBER OF SET "X"  
LINE 0090 MAKER OF SET "X"  
LINE 0100 GRADE OF GAGE BLOCKS IN SET "X"

LINE 0110 TEST NUMBER FOR "Y" SET OF GAGE BLOCKS  
LINE 0120 SUBMITTED BY "Y" CUSTOMER  
LINE 0130 ADDRESS OF "Y"  
LINE 0140 ADDRESS OF "Y"  
LINE 0150 SERIAL NUMBER OF SET "Y"  
LINE 0160 MAKER OF SET "Y"  
LINE 0170 GRADE OF GAGE BLOCKS IN SET "Y"

LINE 0180 NOM, SER(X), COR(X), COEF(X), PEN(X), SER(Y), COR(Y), COEF(Y), PEN(Y)  
LINE 0190 (REPEATS THE ABOVE LINE FOR EACH GAGE BLOCK)  
LINE 0200 COLUMN SUMMATION CHECKS VALUES  
LINE 0210 NOM.SIZE, TEMP, WITHIN, TOTAL, DIFF, T-TEST, STD.DEV., F-TEST  
LINE 0220 (REPEATS THE ABOVE LINE FOR EACH GAGE BLOCK)  
LINE 0230 COLUMN SUMMATION CHECK VALUES

#### Key to abreviations:

NOM	= nominal size	TOTAL	= process standard deviation (long term)
SER	= serial no.	DIFF	= measured difference between the two masters
COR	= correction (deviation from nominal size)	T-TEST	= statistical t-test
COEF	= coefficient of expansion	STD.DEV.	= standard deviation of this run
PEN	= penetration correction	F-TEST	= statistical f-test.
TEMP	= temperature		
WITHIN	= within-group standard deviation		

FIGURE 3



XBASIC GAGE6

Computer input data

RUN

STARTING WITH NOM. SIZE !0.130000  
 ENTER NO. OF GAGE BLOCKS !1  
 WRITE IN DATE W/O COMMA !MAY 15 1974  
 TWO INITIALS OF OBSERVER !GC  
 INSTRUMENT F1, F2, OR F3 !F2  
 (1)KEYBOARD OR (2)DATAFILE!1

SIZE .13 INCH X = 111 Y = GDW  
 S. - S.. !53.2,51.5  
 Y - S. !52.6,52.3  
 X ~ Y !50.1,51.8  
 S.. - X !50.9,50.0  
 S.. - Y !50.8,50.9  
 Y - S. !50.8,51.2  
 S. - X !51.3,49.2  
 X - S.. !49.3,50.0

} Observations  
 (in microinches)

ALL SYSTEMS GO  
 THIS CALIBRATION IS NOW COMPLETE  
 NUMBER OF REPEATS = 0  
 TURN ON PUNCH AND TYPE G.

?LIST REPORT

Print-out of results

0010\* MAY 15 1974  
 0020 GC  
 0030 F2  
 0040 XX123  
 0050 C.E. JOHANNSON CO.  
 0060  
 0070  
 0080 515  
 0090 CEJ  
 0100 GRADE A  
 0110 XY123  
 0120 FORD MOTOR CO.  
 0130 DEARBORN MICH.  
 0140  
 0150 132  
 0160 WEBBER  
 0170 GRADE AA  
 0180 .130000 111 -1.315 11.5 .000 GDW .335 11.5 .000  
 0190 .130000 -1.315 11.5 .000 .335 11.5 .000  
 0200 1 0  
 0210 .130000 20.000 .340 .550 1.150 -.167 .527 2.401  
 0220 .130000 20.000 .340 .550 1.150 -.167 .527 2.401

\* See line numbers in Figure 3 for explanation of print-out. Nominal size is in inches. Corrections (deviations from nominal size) and standard deviations are in microinches. Coefficients of expansion are x 10<sup>-6</sup> per degree Celsius.

FIGURE 4

The results of the 4-1 series intercomparison are explained as to statistical handling of data, history of master blocks and predicted lengths in all size ranges in references 1 and 2.

#### H. Summary

The electro-mechanical length comparator can be utilized to transfer length values very precisely. It is useful to understand the various parameters that affect the comparative process, namely, instrumentation, temperature, block handling techniques and intercomparison design. This paper should be used in conjunction with the references on page 13.

## References

- [1] Pontius, P. E., The Measurement Assurance Program - A Case Study, Part I, Short Gage Blocks (0.1 to 4 inches), NBS Monograph 149 (in process).
- [2] Pontius, P. E., The Measurement Assurance Program - A Case Study, Part II, Long Gage Blocks (5 to 20 inches), will be NBS Monograph (in process).
- [3] Cameron, J. M. & Hailes, G. E., Designs for the Calibration of Small Groups of Standards in the Presence of Experimental Drift, NBS Tech Note 844 (1974).
- [4] Bowman, H. A., Beers, J. S., Gage Block Deformation from Electro-Mechanical Comparators, NBSIR (in process).
- [5] Tucker, C. D., Preparations for Gage Block Comparison Measurements, NBSIR 74-523, 1974.
- [6] Beers, J. S. & Tucker, C. D., Gage Block Flatness and Parallelism Measurement, NBSIR 72-239, August 1973.
- [7] Beers, J. S., A Gage Block Measurement Process Using Single Wavelength Interferometry, NBS Monograph 152, in process.

## APPENDIX

### Experimental Evidence of Thermal Effects in Long Gage Blocks

Figures 5 through 9 summarize the results several thermal experiments on long gage blocks. In all cases temperature was measured with thermocouples inserted halfway down the hole in the square-type blocks and the hole was plugged at each end with a small piece of polyurethane foam.

Figure 5 shows the temperature of two blocks, one in the shadow of the other, as they were exposed to a 40 watt heat source 18 inches away. (Note: The average human generates 100 to 125 watts.) As expected, the temperature of the block in the shadow did not rise as much. Both blocks had nearly identical ground finishes on their sides.

In figure 6, two blocks side by side were exposed to the heat source. In this case, one block had a dull finish on its sides and its temperature rose considerably higher than the brighter finished block. The same two blocks were then individually wrapped in reflective Mylar film and exposed to the heat source again. Figure 7 shows the results - almost identical temperature response and a reduced rise.

Further tests were made of the internal temperatures of four 16-inch blocks while they were being intercompared in the normal "4-1" procedure. Each point in figure 8 indicates the maximum temperature rise of any single block during the 3-1/2 minutes it took to make the intercomparisons. There was no covering on the blocks for the points in the first group, one layer of reflective Mylar was on each block during the runs in the second group, and three layers of Mylar were on each block in the last group of runs. In figure 9, the temperature differences among the four blocks are plotted. Maximum temperature difference between any two blocks at the moment of the first comparison is indicated by a dot for each run and the maximum temperature difference between any two blocks at the moment of the last comparison is indicated by a plus sign.

Temperature differences among long blocks being intercompared are by far the largest sources of uncertainty in the process. These experiments show that temperature stability and equality can be greatly improved by wrapping the blocks in reflective film.

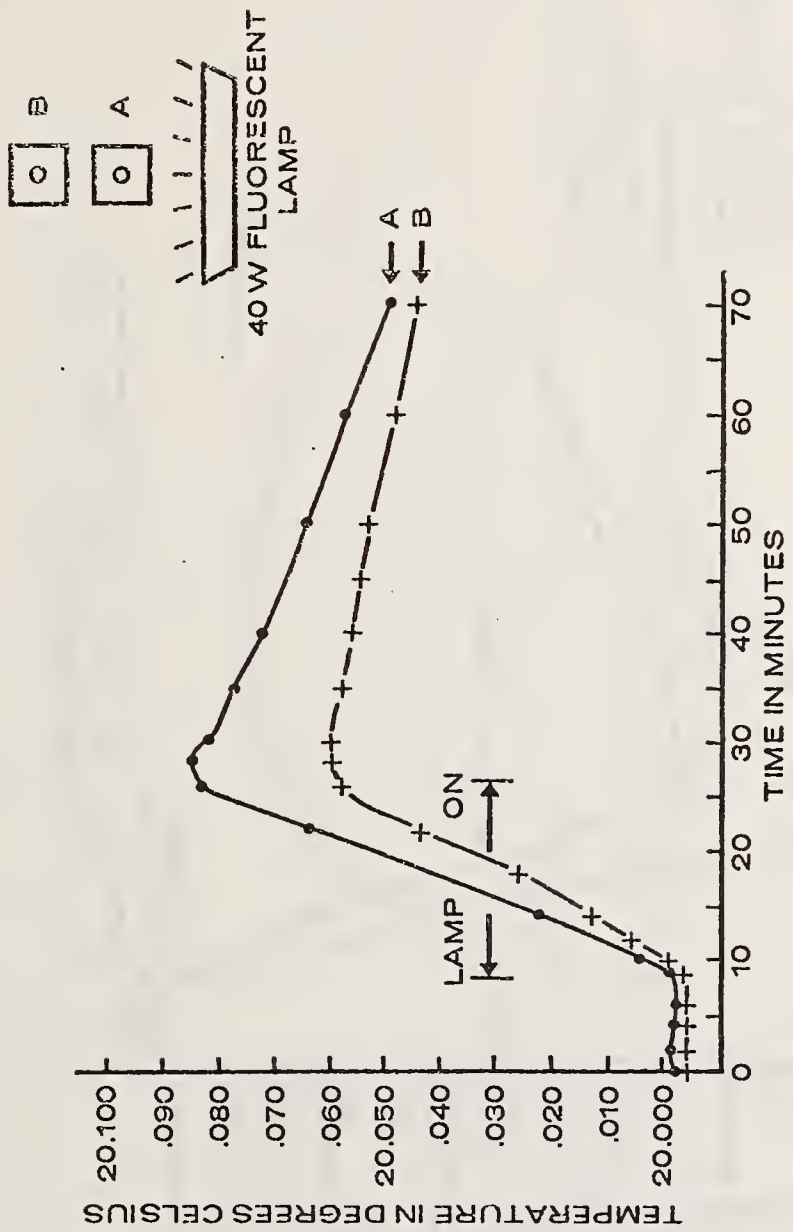

FIGURE 5. TEMPERATURE RESPONSE OF TWO 16-INCH GAGE BLOCKS.

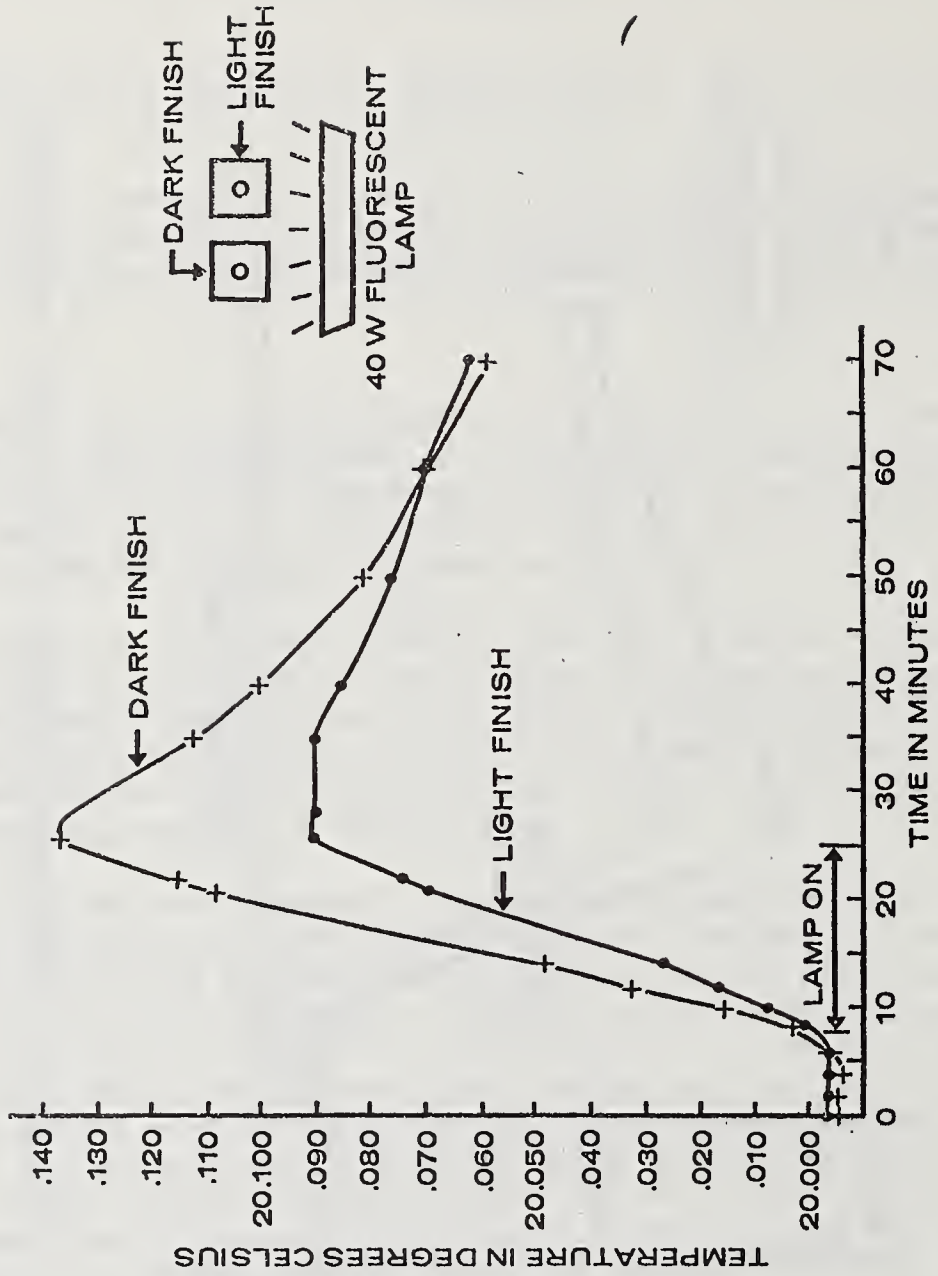

FIGURE 6. TEMPERATURE RESPONSE OF TWO 16-INCH GAGE BLOCKS.

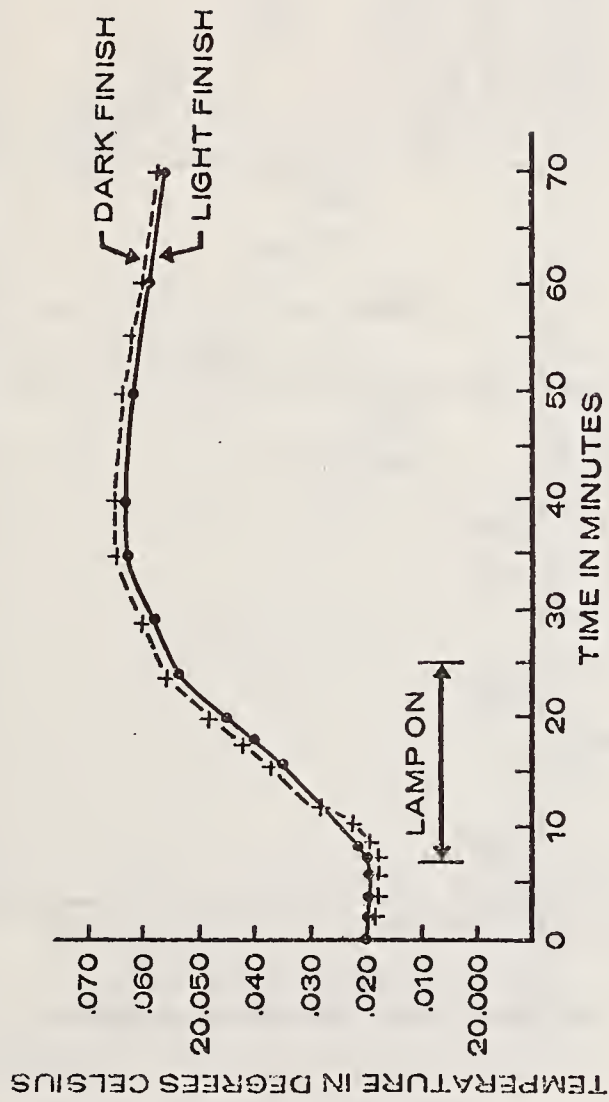

FIGURE 7. TEMPERATURE RESPONSE OF TWO 16-INCH GAGE BLOCKS WRAPPED IN REFLECTIVE FILM.

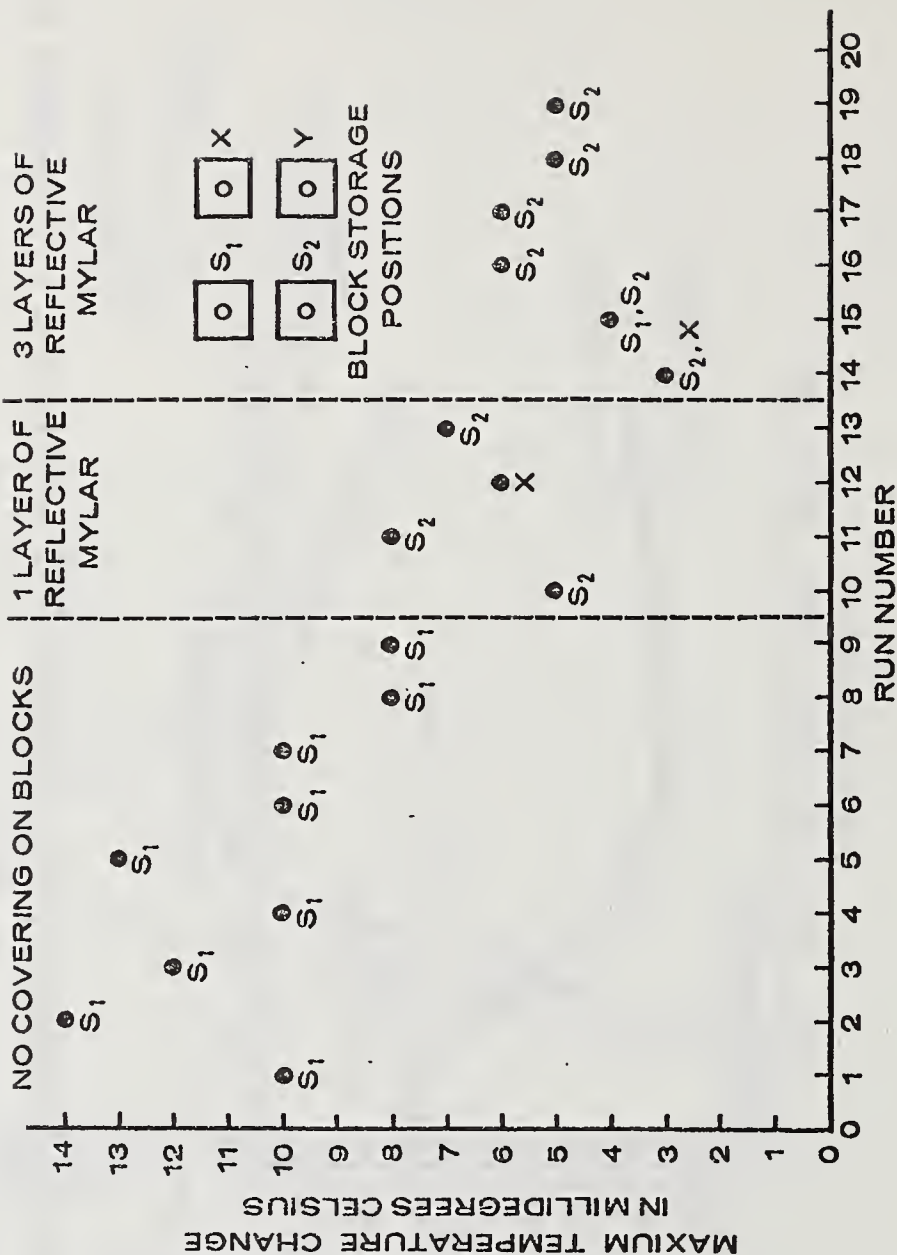

FIGURE 8. TEMPERATURE RESPONSE OF 16-INCH GAGE BLOCKS DURING 3-1/2 MINUTE INTERCOMPARISON PERIODS.



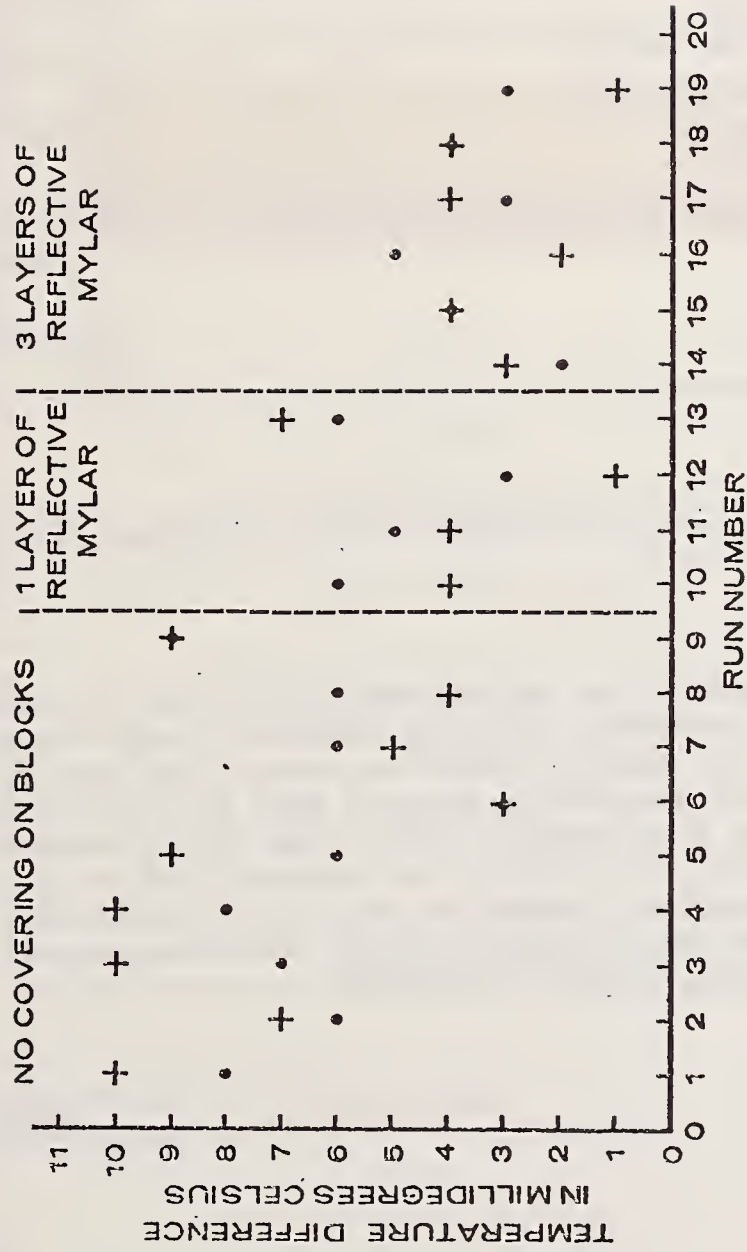

FIGURE 9. MAXIMUM TEMPERATURE DIFFERENCE BETWEEN 16-INCH GAGE BLOCKS AT THE TIME OF (FIRST COMPARISON (o) AND AT THE TIME OF LAST COMPARISON (+).

U.S. DEPT. OF COMM. BIBLIOGRAPHIC DATA SHEET	1. PUBLICATION OR REPORT NO. NBSIR 76-979	2. Gov't Accession No.	3. Recipient's Accession No.	
4. TITLE AND SUBTITLE  INTERCOMPARISON PROCEDURES FOR GAGE BLOCKS  USING ELECTROMECHANICAL COMPARATORS		5. Publication Date January 1976	6. Performing Organization Code	
7. AUTHOR(S) J. S. Beers and C. D. Tucker	8. Performing Organ. Report No.			
9. PERFORMING ORGANIZATION NAME AND ADDRESS  NATIONAL BUREAU OF STANDARDS DEPARTMENT OF COMMERCE WASHINGTON, D.C. 20234		10. Project/Task/Work Unit No. 2131125	11. Contract/Grant No.	
12. Sponsoring Organization Name and Complete Address (Street, City, State, ZIP)  Same		13. Type of Report & Period Covered Final	14. Sponsoring Agency Code	
15. SUPPLEMENTARY NOTES				
<p>16. ABSTRACT (A 200-word or less factual summary of most significant information. If document includes a significant bibliography or literature survey, mention it here.)</p> <p>The widely used procedures for calibrating gage blocks by comparison with blocks of known length generally lack the redundancy needed to evaluate measurement uncertainty or the controls needed to monitor the process on a continuing basis. A detailed description is given here for the systematized intercomparison of groups of four nominally equal gage blocks using an electromechanical comparator. Two of the blocks are unknowns and two are standards. The process provides the redundancy needed for evaluating uncertainty and for continuous monitoring. Gage block thermal effects, equalization time, handling techniques, and observation sequence are described.</p>				
<p>17. KEY WORDS (six to twelve entries; alphabetical order; capitalize only the first letter of the first key word unless a proper name; separated by semicolons)</p> <p>Calibration; comparator, gage blocks; length; measurement process.</p>				
<p>18. AVAILABILITY</p> <p><input checked="" type="checkbox"/> Unlimited</p> <p><input type="checkbox"/> For Official Distribution. Do Not Release to NTIS</p> <p><input type="checkbox"/> Order From Sup. of Doc., U.S. Government Printing Office Washington, D.C. 20402, SD Cat. No. C13</p> <p><input checked="" type="checkbox"/> Order From National Technical Information Service (NTIS) Springfield, Virginia 22151</p>	<p>19. SECURITY CLASS (THIS REPORT)</p> <p>UNCLASSIFIED</p>	<p>21. NO. OF PAGES</p> <p>22</p>	<p>20. SECURITY CLASS (THIS PAGE)</p> <p>UNCLASSIFIED</p>	<p>22. Price</p> <p>\$3.50</p>