



A11107 273264

NBSIR 76-1125
Interim Report
November 1977

Catalog of Artifacts on Display in the NBS Museum

**NIST
PUBLICATIONS**

H.L. Mason, Editor



Special Activities Section
Office of Information Activities
Office of the Associate Director for
Information Programs

U.S. Department of Commerce
National Bureau of Standards
Washington, D.C. 20234

QC
100
.U56
no.76-1112
1977
c.3

NBSIR 76-1125
Interim Report
November 1977

Catalog of Artifacts on Display in the NBS Museum

H.L. Mason, Editor

Special Activities Section
Office of Information Activities
Office of the Associate Director for
Information Programs
National Bureau of Standards
Washington, D.C. 20234



U.S. DEPARTMENT OF COMMERCE, Juanita M. Kreps, *Secretary*
Dr. Sidney Harman, *Under Secretary*
Jordan J. Baruch, *Assistant Secretary for Science and Technology*
NATIONAL BUREAU OF STANDARDS, Ernest Ambler, *Acting Director*

Guide to Artifacts

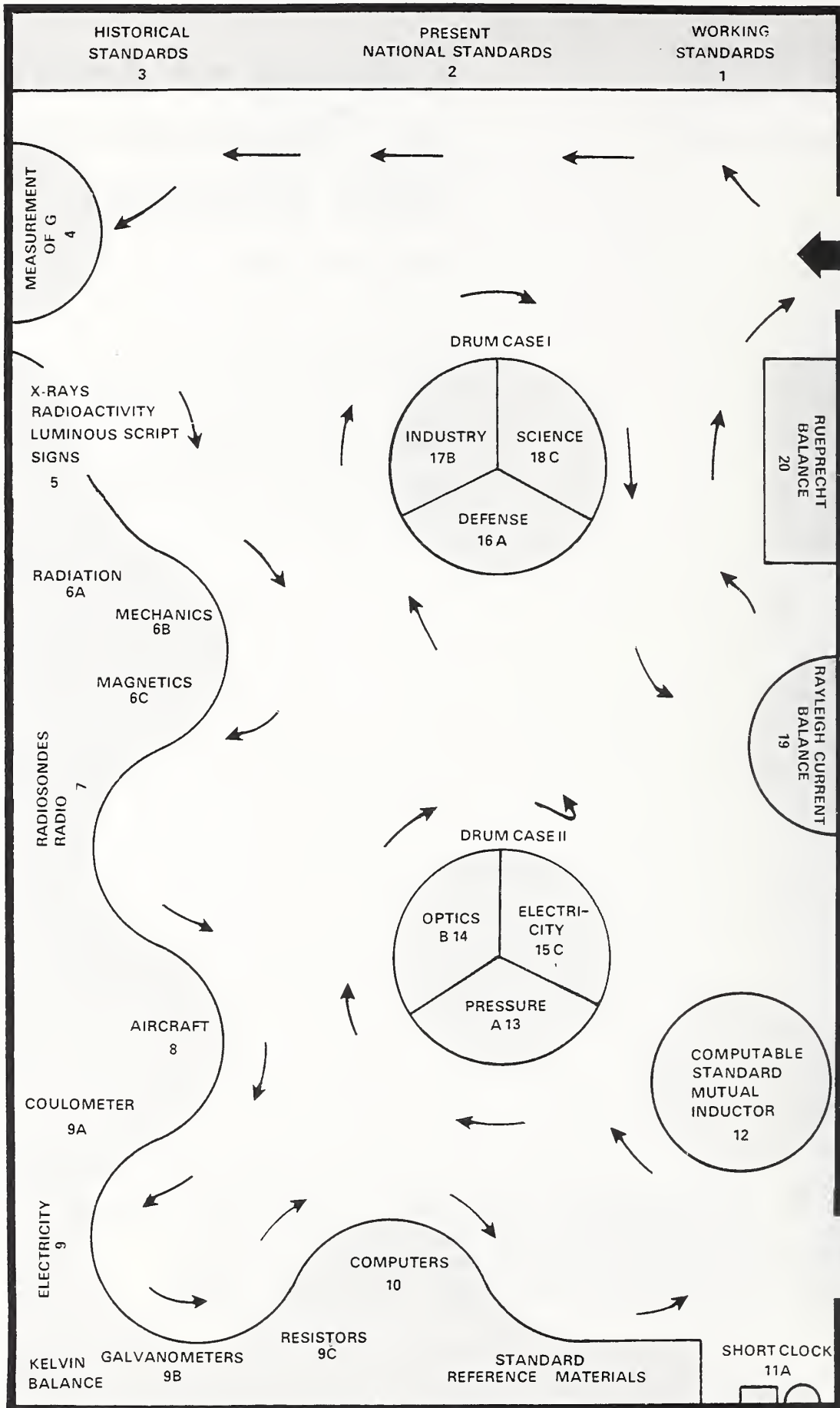

Edge Index

		Introduction	▨
		Museum Displays Atlas	▨
AREA 1	VAULT	Working Standards	▨
AREA 2	VAULT	National Standards	▨
AREA 3	VAULT	Historical Standards	▨
AREA 4		Gravitation	▨
AREA 5	FLAT CASE	Radioactivity & X-Rays	▨
AREA 6	FLAT CASE	Radiation, Mechanics, Magnetics	▨
AREA 7	FLAT CASE	Radio	▨
AREA 8	FLAT CASE	Aircraft	▨
AREA 9	FLAT CASE	Electricity	▨
AREA 10	FLAT CASE	Standard Reference Materials (SRM's)	▨
		Standards Eastern Automatic Computer (SEAC)	▨
AREA 11		Time	▨
AREA 12		Electrical Resistance	▨
AREA 13	DRUM CASE II	Pressure	▨
AREA 14	DRUM CASE II	Electricity	▨
AREA 15	DRUM CASE II	Optics	▨
AREA 16	DRUM CASE I	Defense	▨
AREA 17	DRUM CASE I	Industry	▨
AREA 18	DRUM CASE I	Science	▨
AREA 19		Ampere	▨
AREA 20		Balance	▨



CATALOG OF ARTIFACTS ON DISPLAY IN THE NBS MUSEUM

This museum is designed to preserve and display apparatus and other memorabilia illustrative of the past scientific work of NBS for the information of visitors, for the inspiration of present and future staff members, and as a part of the historic record of the evolution of the science of physical measurement.

Most visitor's casual interest will be satisfied by the cards placed beside the individual items. However, if one really wants to understand the artifact, this catalog will tell how the instrument worked, what its technical purpose was, and what part it played in the long development of scientific achievement at the National Bureau of Standards. For the scientist or engineer who wants further details, these may be found in the references appended, all of which are available in our library. The arrangement by scientific, industrial or historical categories makes it easy to choose the groups which are of particular interest to the visitor.

The Museum's archival repository maintains source materials for all of the items currently on display as well as for over 400 additional artifacts in its custody.



MUSEUM DISPLAY ATLAS

M indicates assigned Museum Number
R indicates Reference Standard

	<u>Museum Number</u>	<u>Page</u>
AREA 1 - VAULT-WORKING STANDARDS		
<u>Pyrometry</u>		
Lamp, tungsten strip	M526	3-4, 5p
<u>Photometry</u>		
Blackbody, platinum, Waidner-Burgess model	M197	6-7, 49-50, 51p
Lamp, carbon filament	M198	8p
Lamp, tungsten filament, vacuum	M227	8p
Lamp, tungsten filament, gas-filled	M228	6, 8p
Lamp, tungsten filament, vacuum	M229A	9p
Lamp, tungsten filament, gas-filled	M229B	9p
Lamp, fluorescent	M230	7, 10p
<u>Electrical Resistance</u>		
Resistor, one-ohm double-walled, Thomas	R7	11, 12p, 43, 44p, 73
<u>Electromotive Force</u>		
Standard cell group, Weston, NBS	M281	13, 14p, 15p
<u>Length</u>		
Meter, Prototype No. 27	R1	17, 18p
Meter, Prototype No. 21	R2	17
Gage Blocks	M569	19, 20p
<u>Temperature</u>		
Thermocouple, platinum-10 percent rhodium vs. platinum	M522	21, 23p
Thermometer, platinum resistance	M523	21, 23p
<u>Frequency</u>		
Quartz Crystal Resonator	M571	25, 26p

AREA 2 - VAULT-NATIONAL STANDARDS

Length

Lamp, krypton 86	M543	30, 31p
------------------	------	---------

Mass

Kilogram, Prototype No. 20, replica	R5	33, 35p
Kilogram, Prototype No. 4, replica	R6	33

Temperature

Triple point cell, water	M524	37, 38p
--------------------------	------	---------

Time and Frequency

Cesium Oven	M375	39, 40p, 41p
-------------	------	--------------

Electric Current

Resistor, one-ohm double-walled, Thomas	R7	11, 12p, 43, 44p, 73
Josephson junction, voltage	M550	45, 46p, 47p

Luminous Intensity

Blackbody, platinum, Waidner-Burgess model	M197	6, 7, 49-50, 51p
--	------	------------------

AREA 3 - VAULT-HISTORICAL STANDARDS

Mass

Pound, troy	M446	55, 57p
Pound, avoirdupois, "Star"	M323	55, 58p
Pound, avoirdupois, Imperial, copy No. 5	M324	55-56, 59p
"Grave" weight	M322	61, 63p
Kilogram/Liter	M448	61, 64p
Kilogram, "Committee"	M319	62, 65p
Kilogram, Silbermann	M321	62, 66p

Electric Current

Voltmeter, silver, Rayleigh	M172	67, 69p
Voltmeter, silver, Kohlrausch	M175	67, 70p
Voltmeter, silver, Richards	M170	67, 71p
Voltmeter, silver, Smith	M171	67, 72p

Electrical Resistance

Resistor, one-ohm, P.T.R.	M334	73, 74, 76p
Resistor, one-ohm, B.A.	M44	73, 74, 75p
Resistor, one-ohm, Rosa	M28	73, 74, 77p
Mercury ohm tubes	M137	78, 79p

Electromotive Force

Standard cell, Clark-Fuessner	M279	81, 82, 83p
Standard cell, Carhart-Clark	M280	81, 84, 85p
Standard cell, Weston-Berlin No. 508	M283	86, 87p
Standard cell, Kahle	M282	88, 89p

Frequency

Oscillator, quartz, Marrison	M373	91, 92p
------------------------------	------	---------

Temperature

Thermometer, mercury-in-glass, Tonnelot	M520A	93, 94p
Thermometer, mercury-in-glass, Baudin M521	M520B,C,	93, 94p

Length

Cubit, Egyptian Royal, model	M444	95, 96p
Scale, Troughton	M316	98, 99p, 100p
Yard, bronze No.11	M317	101, 102p
Yard, Low Moor iron No. 57	M318	103, 104p
Meter, "Committee"	M314	105, 106p
Meter, Arago platinum	M315	107, 108p

Luminous Intensity

Candles, standard, with balance	M269	109, 110p
Flame standard, Carcel	M270	109, 111p
Flame standard, Hefner	M271A,B	109, 112p

AREA 4 - GRAVITATION

Gravitation apparatus, mockup, Heyl	M561	115, 116p
Glass balls for gravitation apparatus, Heyl	M12	115, 117p

AREA 5 - FLAT CASE-RADIOACTIVITY AND X-RAYS

Luminous script signs	M272	121, 122p
Ionization chamber, guarded field, Taylor	M337	123, 124p
Radioactivity counter, Seliger/Cavallo	M340	127, 128p

AREA 6 - FLAT CASE-RADIATION, MECHANICS, MAGNETICS

Thermopoles, Coblentz	M202	129, 130p
Strain gage, Tuckerman	M34	131, 132p, 133d
Strain gage, Whittemore	M36	135, 136p
Magnegage, Brenner	M415	137, 138p
Permeameter, Burrows	M182	139, 140p
Magnetic particle clutch, Rabinow	M2	141, 142p
Magnetic balance, Sanford	M19	143, 144p

AREA 7 - FLAT CASE-RADIO

Electric hygrometer, Dunmore	M33	147, 148p
Radiosonde, Curtiss-Astin	M167	149, 150p
Radiosonde, early type	M163	149, 150p
Radiosonde, tube type	M164	149, 150p
Radiosonde, transistor type	M165	149, 150p
Radio receiver, alternating current	M166	151, 152p
Decremeter, Kolster	M83	153, 154p

AREA 8 - FLAT CASE-AIRCRAFT

Course indicator, two-reed, type C	M86	157, 158p
Course indicator, two-reed, type D	M87	157, 158p
Runway localizer	M84	159, 160p
Glideometer, fog landing	M85	159, 160p
Combined landing instrument	M106	159, 160p

AREA 9 - FLAT CASE-ELECTRICITY

Bridge for resistance thermometry	M290	163, 164p
Electrothermic voltmeter, Hermach	M313	165, 166p
Shunt box, Waidner-Wolff	M393	167, 168p
Resistor, adjustable non-inductive, Agnew	M97	169, 170p
Resistor, one-ohm double walled, Thomas	M42	171, 172p
Coulometer, perchloric acid	M176	173, 174p
Galvanometer, vibrating reed	M98	175, 176p
Galvanometer, adjustable sensitivity, Wenner	M39	177, 178p
Galvanometer, moving magnet, Coblentz	M219	179, 180p, 181d
Galvanometer, remotely tuned, Silsbee	M95	182, 183p
Ammeter, Kohlrausch	M103	185, 186p
Resistor, non-reactive, Curtis	M53	187, 189p
Resistor, non-reactive, Wenner	M454	187, 190p
Resistor, non-reactive, Moon	M52	187, 191p
Resistor, non-reactive, Woven and Card	M50	188, 192p
Current balance, Kelvin	M89	193, 194p, 195d

**AREA 10 - FLAT CASE - Standard Reference Materials (SRMs)
 - Standards Eastern Automatic Computer (SEAC)**

Representative SRMs		199, 200p
Representative SEAC Components	M538	201-202, 203p

AREA 11 - TIME

Clock, Shortt	M516	207, 208p, 209d
Clock, Riefler	M515	210, 211p, 212d

AREA 12 - ELECTRICAL RESISTANCE

Mutual inductor, Wenner	M41	215, 216p
-------------------------	-----	-----------

AREA 13 - DRUM CASE II - PRESSURE

Barometer, U-tube	M462	220, 221p
Vacuum pump, two-stage, Stimson	M414	223, 224p, 225d
Optical Cell, diamond anvil	M325	227, 228p, 229p
Pressure apparatus, tetrahedral anvil	M38	231, 232p

AREA 14 - DRUM CASE II - OPTICS

Spectrometer, Societe Genevoise	M14	236, 237p
Interferometer, Fabry-Perot, NBS	M275	239, 240p, 241d
Wavelength standard, neon	M398	243, 244p
Wavelength standard, mercury-198	M274	243, 244p
Wavelength standard, cadmium	M400	243, 244p

AREA 15 - DRUM CASE II - ELECTRICITY

Capacitor, cylindrical	M30	248, 250p, 251d
Capacitor, parallel plate	M47	248, 252p
Electrodynamometer	M68	253, 254p
Wattmeter, heavy-duty, Brooks	M366	255, 256p
Potentiometer, deflection, Brooks	M24	257, 258p

AREA 16 - DRUM CASE I - DEFENSE

Sound-ranging system, World War I	M480	262, 263p
Naval ordnance studies, World War I	M71,72,77	265, 266p
Proximity fuzes, World War II	M4,5,6	267, 268p
Carbon monoxide detector tubes, Shepherd, World War II	M193	269, 270p
Buoy circuit assembly, Tinkertoy, World War II	M443	271, 272p
Mine, constant depth, World War II	M100	273, 274p
Uranyl nitrate crystals, World War II	M82	275, 276p
Graphite, high purity, World War II	M81	277, 278p

AREA 17 - DRUM CASE I - INDUSTRY

Saccharimeter, Bates	M418	282, 283p
Flexometer, Schiefer	M331	285, 286p
Planoflex, Dreby	M332	287, 288p
Indenter, pyramidal, Knoop	M155	289, 290p, 291d
Contractometer, spiral, Brenner	M416	293, 294p
Printing plate, electroformed	M441	295, 296p

AREA 18 - DRUM CASE I - SCIENCE

Radiation balance, microcalorimeter, Mann	M339	300, 301p
Calorimeter, water	M509	303, 304p
Proving ring, Whittemore-Petrenko	M504	305, 306p
Atomic weight of hydrogen (Palladium used), Noyes M9	M9	309, 310p
Heavy water, Washburn	M11	311, 312p
Omegatron M7	M7	313, 314p

AREA 19 - AMPERE

Coils, Rayleigh current balance	M69	315, 317p
---------------------------------	-----	-----------

AREA 20 - BALANCE

Rueprecht balance	M291	321, 322p, 323d
-------------------	------	-----------------

AREA 1 VAULT

Working Standards



WORKING STANDARD OF PYROMETRY

TUNGSTEN STRIP LAMP

1946

M526

Precise temperature measurements in science and technology are based on the International Practical Temperature Scale of 1968. On this scale, high temperatures (those above the melting point of gold, i.e., 1064 °C) are defined in terms of the Planck radiation law which relates spectral radiance to temperature and wavelength. The instrument used to realize the scale at the National Bureau of Standards is a photoelectric pyrometer, calibrated relative to a gold-point blackbody source. Tungsten strip lamps, such as the one shown here, are calibrated with the pyrometer and serve as convenient secondary standards. This lamp is gas filled and has a ribbon filament 0.075 mm thick, 3 mm wide, and 50 mm long. To increase the reproducibility of observations, the pyrometer is sighted near the notch. The v-bend in the ribbon allows expansion and contraction without twisting or bending as the temperature is changed. Rated at 6 volts/30 amperes, the lamp requires about 14 amperes for a brightness temperature of 1000 °C and about 40 amperes for 2300 °C.

The calibration of tungsten strip lamps at NBS was, for many years, done with a visual optical pyrometer based on the 1923 design of Fairchild and Hoover. In 1966, the High Temperature Measurement Section completed development of the photoelectric pyrometer and a horizontal gold-point blackbody, resulting in a significant improvement in both precision and accuracy. Other national laboratories have also developed photoelectric pyrometers. The accuracy with which tungsten strip lamps are calibrated is indicated by the results of an international comparison completed in 1972. The laboratories participating in this intercomparison included NBS, the Physikalisch-Technische Bundesanstalt in Germany, the National Measurements Laboratory in Australia, and the National Physical Laboratory in England. The maximum difference between the calibrations of the laboratories was a few tenths of a degree from 1064 °C to 1700 °C and 2 °C at 2200 °C. In general, these differences are less than the sum of the uncertainties assigned to the calibrations by any two of the laboratories.

References

- Kostkowski, H. J. and Lee, R. D., Theory and Methods of Optical Pyrometry, Nat. Bur. Stand. (U.S.), Monogr. 41 (1962).
- Lee, R. D., The NBS photoelectric pyrometer and its use in realizing the International Practical Temperature Scale above 1063 °C, Metrologia 2, No. 4, pp. 150-162 (Oct. 1966).

Lee, R. D. and Kostkowski, H. J.; Quinn, T. J. and Chandler, P. R.; Jones, T. P. and Tapping, J.; and Kunz, H., Intercomparison of the IPTS 68 Above 1064 °C by Four National Laboratories, Temperature, Its Measurement and Control in Science and Industry (Instrument Society of America, Pittsburgh, Pa., 1972), Vol. 4, Part 1, p. 377.

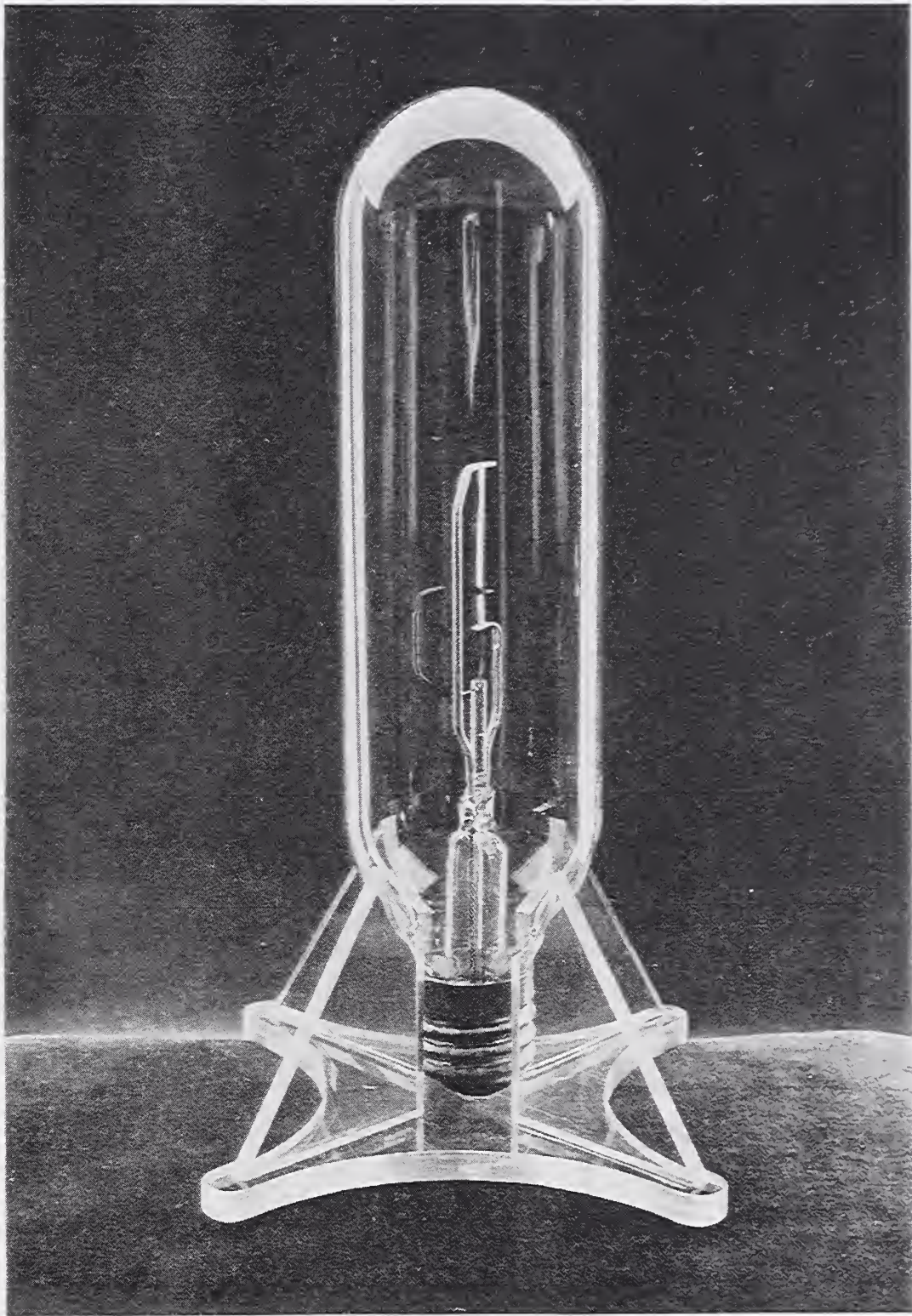

Tungsten Strip Lamp (1946) M526

WORKING STANDARDS OF PHOTOMETRY

As early as 1903, NBS adopted seasoned carbon-filament lamps as photometric working standards, having compared them with the Hefner lamp (M271) of the Reichsanstalt. Using about 4 watts per candle, they operate at a filament color temperature of about 2100 K, hence their light is of nearly the same color as that from the Waidner-Burgess standard blackbody.

In 1906, E. P. Hyde carried to Europe nine 50-volt, 64-watt, horse-shoe filament lamps (similar to M108) which had been standardized for intensity in a specific direction defined by lines etched on the bulb. Another nine taken were 110-volt, 64-watt, oval anchored filament lamps which had been standardized for mean horizontal intensity by the method of rotation. These were intercompared with similar lamps in London, Paris, and Berlin which had been compared with Harcourt (M65), Carcel (M270), and Hefner lamps, respectively. Upon return to NBS, the mean value of intensity of these lamps was found to be within 2 or 3 parts per 1000 of the original value. They were thereupon adopted as the National Reference Standard, and similar lamps were sold to users until the tungsten filament was developed. In 1909 an "international candle" was adopted.

By 1914 two-thirds of the incandescent lamps submitted to NBS for certification had the more efficient tungsten filaments operating at a color temperature of about 2360 K, blue in comparison with carbon-filament standards. In photometry, this color difference was compensated for by the use of a standard blue-glass screen placed in the path of the light from the carbon-filament working standard. Another procedure for coping with the color difference was the use of flicker photometry.

Larger lamps (200, 450, 750 or 1000 watts) have an efficiency of about 0.7 watt per candle, and are argon-filled, with tungsten filaments coiled as a closely wound helix (M228). These lamps operated at a color temperature of about 2850 K. The same blue filter that compensated for the color difference between 2100 K and 2360 K was used to compensate for the color difference between 2360 K and 2850 K.

In 1908 C. W. Waidner and G. K. Burgess, both of NBS, had suggested that a prototype standard of light based on the light emitted from a blackbody immersed in a bath of freezing platinum would have many advantages over the earlier proposal of Violle which was to use light from the surface of the metal.

In 1928, H. T. Wensel, W. F. Roeser, L. E. Barbrow, and F. R. Caldwell at NBS, set up such a standard and compared it with the national reference standard carbon filament lamps which had been assigned values in 1909 in terms of an agreed "international candle." They obtained a value of 58.84 ± 0.20 or -0.09 candles per square centimeter. By international agreement, effective January 1, 1948, a new unit called the "candela" was put into use internationally, having been approved by the General Conference on Weights and Measures (CGPM). The new standard was defined to have a luminance of 60 candela per square centimeter.

This model of the Waidner-Burgess standard of light (M197) shows in cross-section the thoria crucible, metal in the space occupied by the freezing platinum, and a thoria tube (the blackbody) in the center thereof.

Luminous intensity and luminous flux of incandescent lamps can now be referred to tungsten lamps calibrated against the platinum blackbody. Fluorescent tubes up to 96 inches in length have been calibrated against incandescent lamps in large spherical photometers.

References

- Hyde, E. P., Comparison of Units of Luminous Intensity, Bull. Nat. Bur. Stand. 3, 65 (1907).
- Middlekauff, G. W. and Skoglund, J. F., Photometry of the Gas-Filled Lamp, Bull. Nat. Bur. Stand. 12, 587 (1915-16).
- Page, C. H. and Vigoureux, P., Eds., The International System of Units, Nat. Bur. Stand. (U.S.), Spec. Publ. 330 (1972).
- Wensel, H. T., Roeser, W. F., Barbrow, L. E., and Caldwell, F. R., The Waidner-Burgess Standard of Light, Nat. Bur. Stand. (U.S.), J. Res. 6, 1103, RP325 (1931).

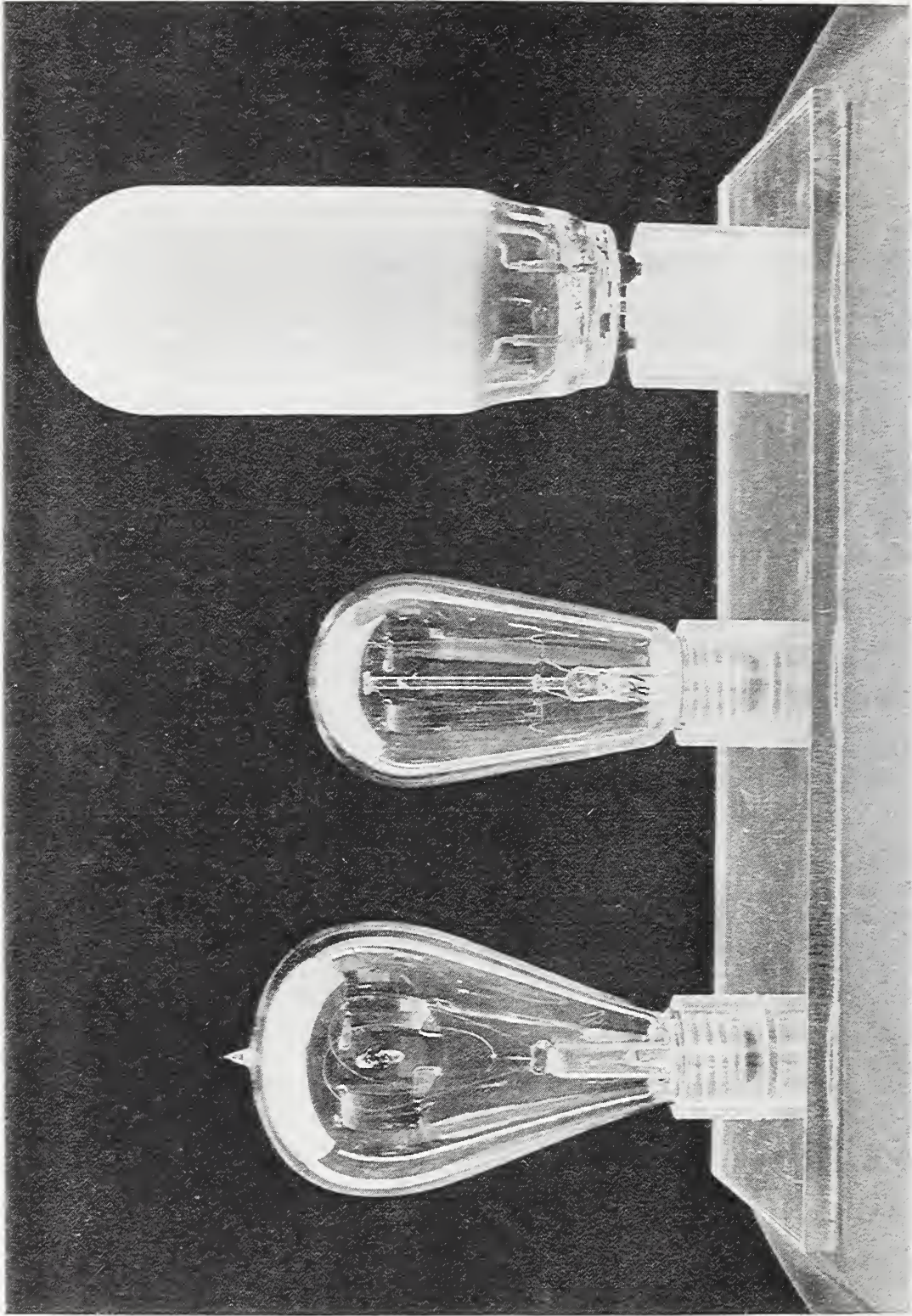

Luminous Intensity Standard Lamps
M198 M227 M228

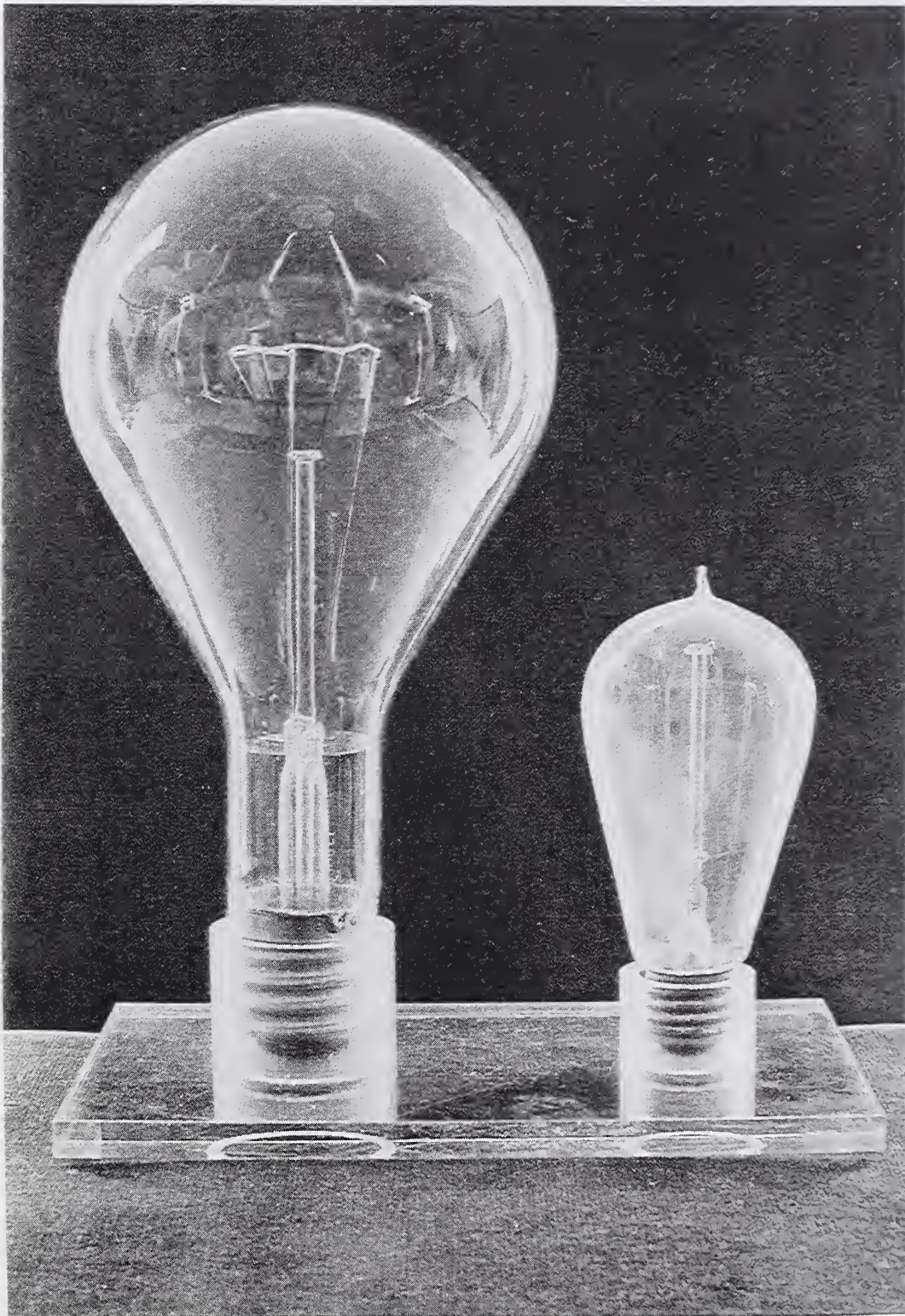

Luminous Flux Standard Lamps (1917 to Present) M229A, 229B

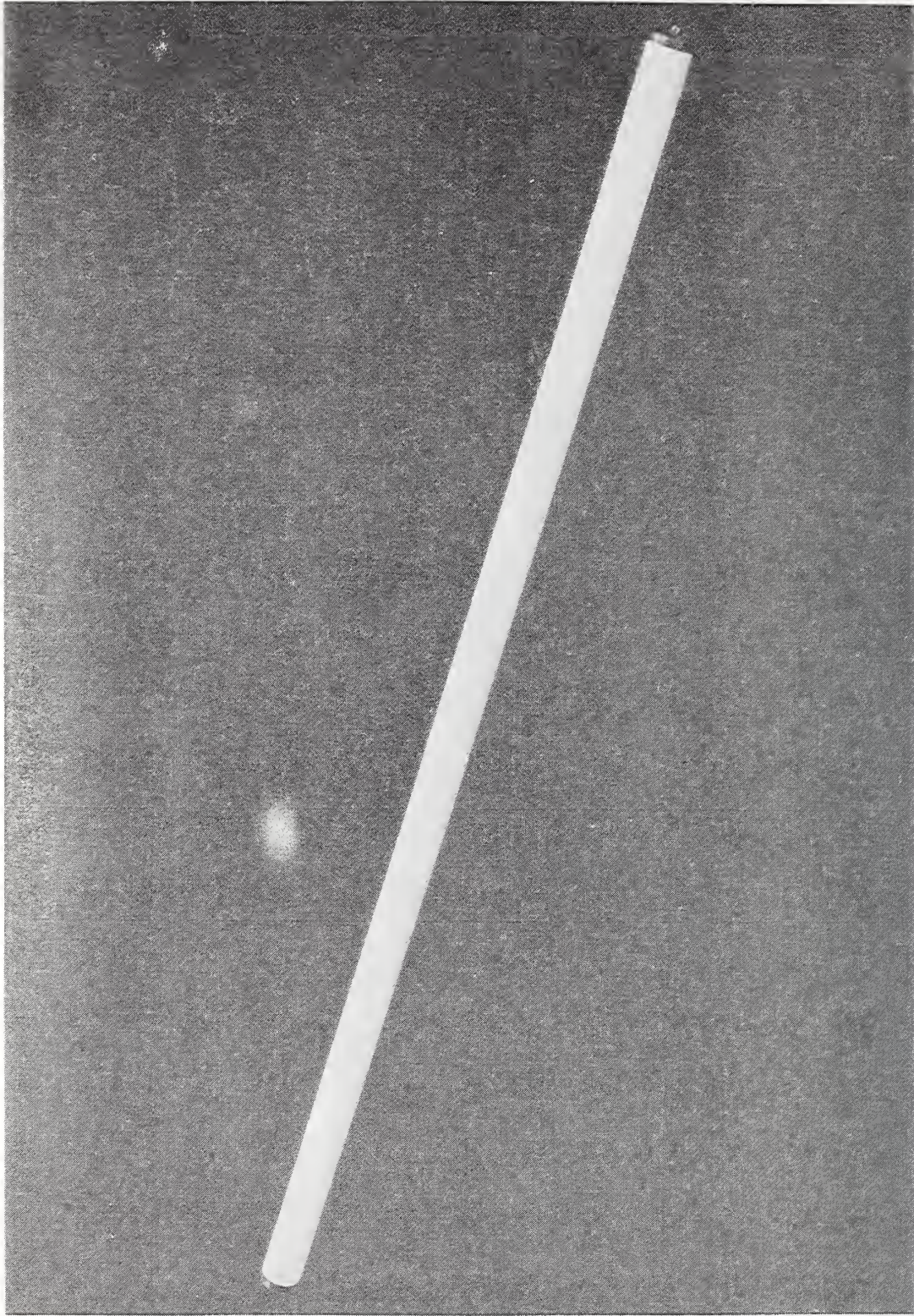

Luminous Flux Standard for Fluorescent Lighting M230

WORKING STANDARD OF ELECTRICAL RESISTANCE

ONE-OHM RESISTOR, DOUBLE-WALLED 1930

R7

In this type of standard resistor developed by J. L. Thomas a single layer of bifilar manganin wire is wound on a mandrel and annealed in a vacuum at red heat. It is then slipped onto a silk-insulated 6-cm brass cylinder with only loose contact between them. This tube is closed by soldering its flanged ends to an outer 7-cm tube. The coil is sealed in place with dry air and the leads for electrical connections are brought out through seals.

Previous to 1910 the U.S. reference standard of electrical resistance was maintained by resistors of the Reichsanstalt type (M293) obtained from Germany. From 1910 to 1930 the standard was a group of 10 one-ohm coils of a design of E. B. Rosa (M28). Between 1930 and 1939 these were gradually replaced by the double-walled type. The maximum net change of the latter group, with respect to the mean of the ten, measured at yearly intervals from 1939 to 1969, has been only one part per million.

References

- Thomas, J. L., A new design of precision resistance standard, Nat. Bur. Stand. (U.S.), J. Res. 5, 295 (Aug. 1930).
- Thomas, J. L., Stability of double-walled manganin resistors, Nat. Bur. Stand. (U.S.), J. Res. 36, 107 (Jan. 1946).
- Wells, T. E., Precision Measurement and Calibration, Vol. 3, Electricity-Low Frequency, Nat. Bur. Stand. (U.S.), Spec. Publ. 300, p. 139-111 (Dec. 1968).

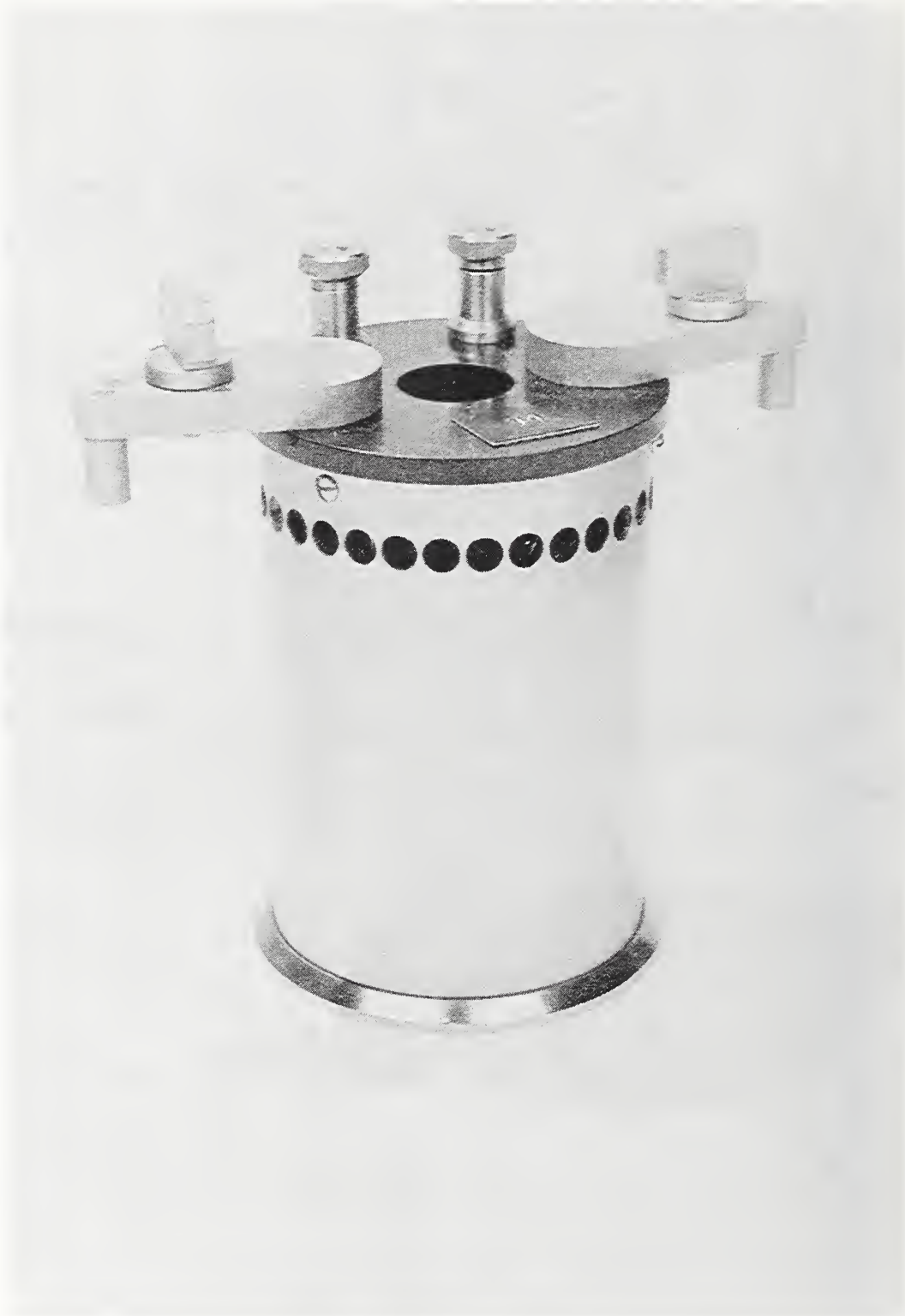

One-Ohm Resistor, Double-Walled (1930) R7

WORKING STANDARD OF ELECTROMOTIVE FORCE

WESTON STANDARD CELL

1905

M281

From 1893 to 1972 the international standard of electromotive force (emf) has been based on an electrochemical "standard" cell. In 1910 scientists from England, France, and Germany met at NBS to construct a large group of Weston standard cells and assign a voltage to them. Using a number of silver coulometers to fix the ampere, and a number of resistors to fix the ohm, they adopted the value 1.0183 volts at 20 °C, using the Ohm's law relation $\text{volt} = \text{ampere} \times \text{ohm}$.

The Weston cell has a positive electrode consisting of a paste of mercury and mercurous sulfate Hg_2SO_4 , the negative electrode being an amalgam containing about 10 percent cadmium, with a saturated solution containing cadmium sulfate $\text{CdSO}_4 \cdot 8/3\text{H}_2\text{O}$ crystals as an electrolyte. The H-form of container used at NBS is made of soda-lime glass with a coefficient of linear expansion approximately that of the platinum lead-wires. The vertical limbs about 16 mm in diameter have constrictions near the base to lock in part of the crystals.

Between 1910 and 1972 the U.S. legal volt was maintained by a group of Weston saturated cells which were held at a constant temperature in an oil bath. The mean electromotive force was assumed to remain constant. As new and stable cells were made they were introduced into the reference group, which grew to 44 cells. In 1969, reflecting improved realization of the ohm and the ampere, the international standard for the Weston cell was fixed at 1.018 328 6 volts. Subsequent check of the U.S. Standard cell group against the Josephson junction (M550) has shown that the group emf has actually been drifting down slightly, but by less than 3 parts in 10,000,000 per year.

References

- Hamer, W. J., Standard Cells: Their Construction, Maintenance, and Characteristics, Nat. Bur. Stand. (U.S.), Monogr. 84 (1965).
- Eicke, W. G. and Cameron, J. M., Designs for Surveillance of the Volt Maintained by a Small Group of Saturated Standard Cells, Nat. Bur. Stand. (U.S.), Tech. Note 430 (Oct. 1967).
- Nat. Bur. Stand. (U.S.), Tech. News Bull. 54, 43 (Feb. 1970).
- Field, B. F., Finnegan, T. F., and Toots, J., Volt maintenance at NBS via $2e/h$: A new definition of the NBS volt, Metrologia 9, 155 (1973).

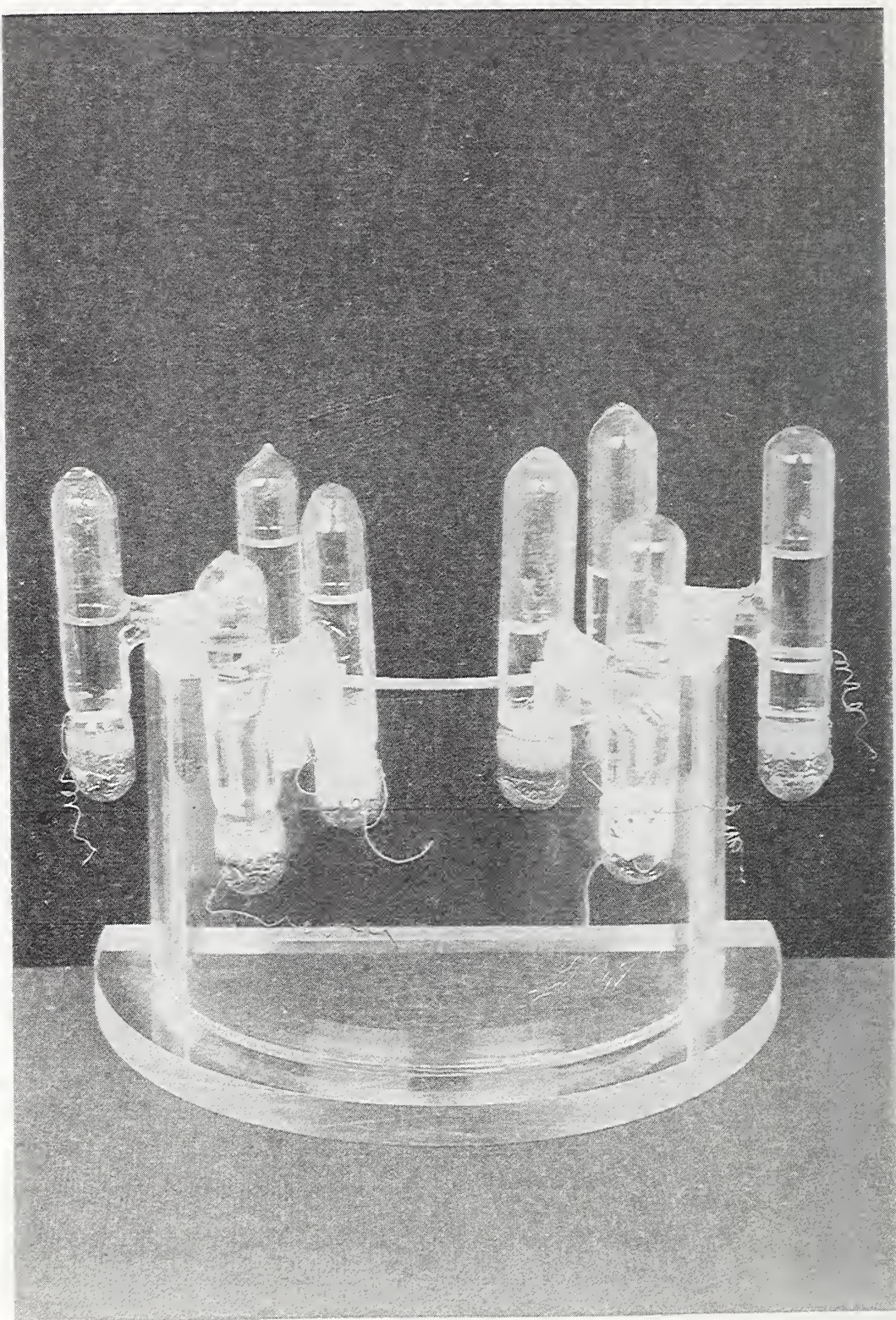

Weston Standard Cell (1905) M281

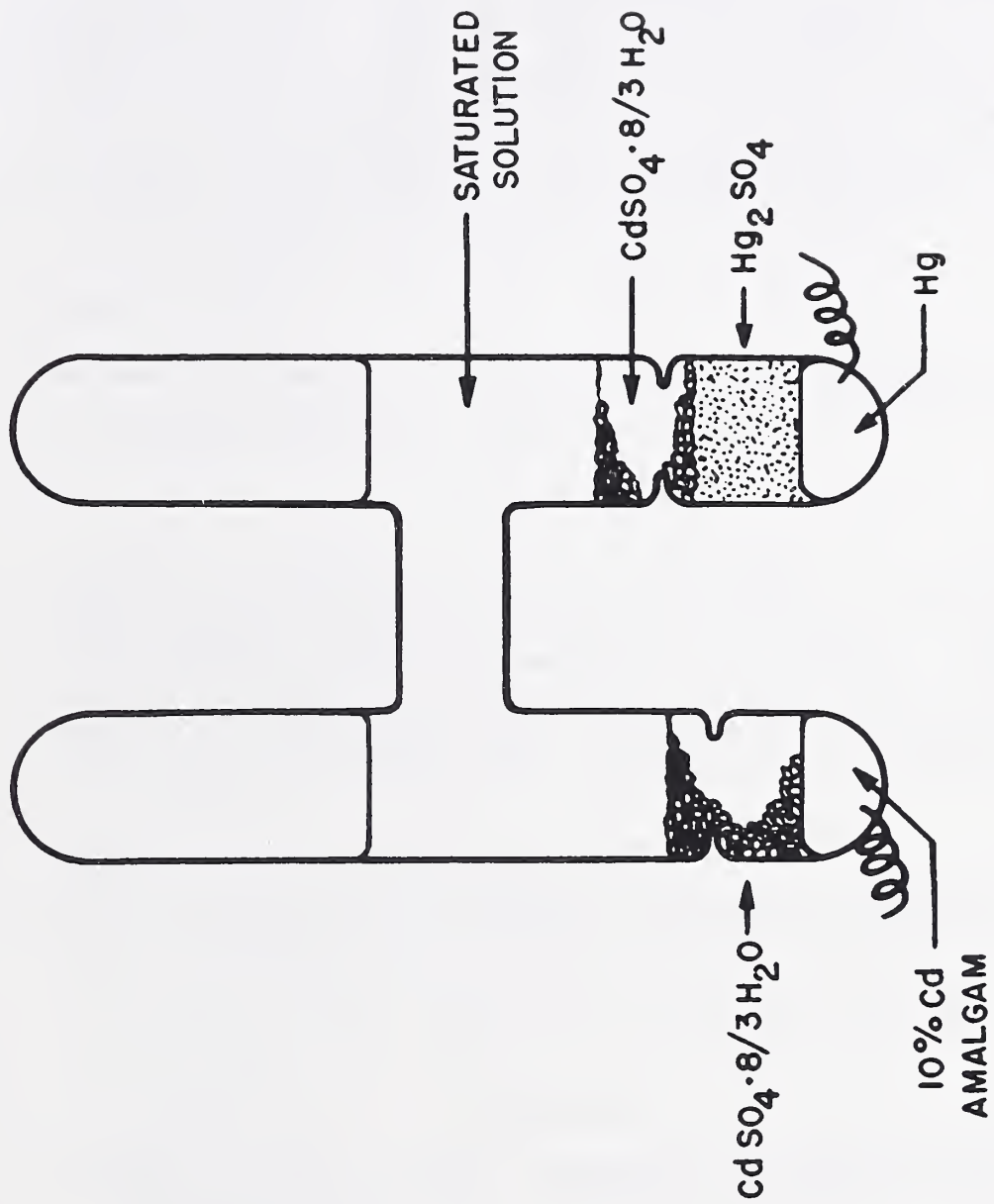

Cross section drawing of the Weston Standard Cell (1905) M281

WORKING STANDARDS OF LENGTH

After the Treaty of the Meter had been signed in 1875, the International Bureau of Weights and Measures (BIPM) at Sèvres made 31 prototype line standards of platinum - 10 percent iridium alloy. These have a modified X-section named for Henri Tresca who devised it. Small elliptical areas on the upper surface of the central rib at each end of the bars are highly polished, and three lines nominally 0.5 mm apart are ruled on these surfaces, the distance between the middle lines of each group defining the standard length. One bar, having the length of the Mètre des Archives, was selected as the International Meter. Intercomparisons between it and the 31 National Prototypes yielded a "probable error" of ± 0.04 micrometer, and the uncertainty at temperatures between 20 and 25 °C was estimated by BIPM to lie between $\pm 0.1 \mu\text{m}$ and $\pm 0.2 \mu\text{m}$.

METER No. 27

1889

R1

National Prototype No. 27 was sent to the United States by Delegate B. A. Gould, and received by President Harrison on January 2, 1890. It was certified to have a length of

$$1 \text{ m} - 1.6 \mu\text{m} + 8.657 \mu\text{m} \cdot T + 0.001 \mu\text{m} \cdot T^2 \pm 0.2 \mu\text{m}$$

with T in degrees centigrade. Recertification at 0 °C gave the values 1 m-1.48 μm in 1922, 1 m-1.47 μm in 1933, and 1 m-1.45 μm in 1957. When the Mendenhall Order in the Report for 1893 (Coast and Geodetic Survey) declared the meter to be a fundamental standard, No. 27 became the U.S. reference standard for all length measurements. It remained the primary prototype in 1960, secondary only to the basic value in terms of the wavelength of krypton 86.

METER No. 21

1890

R2

National Prototype No. 21 is of the same material and design as No. 27. It was received from BIPM later in 1890, certified as

$$1 \text{ m} + 2.5 \mu\text{m} + 8.665 \mu\text{m} \cdot T + 0.00100 \mu\text{m} \cdot T^2 \pm 0.2 \mu\text{m}$$

References

Tittmann, O. H., National Prototypes of the Standard Metre and Kilogramme, Appendix No. 18 - Report for 1890, U.S. Coast and Geodetic Survey.

Judson, L. V., Weights and Measures of the United States, Nat. Bur. Stand. (U.S.), Misc. Publ. 247 (1963).



Meter No. 2/ (1889) RI

Insert shows detailed view of modified X section

In machine shops, these lengths of short workpieces are measured by comparing them with a stack of these accurately ground and polished end standards. Over 100,000 length combinations are obtainable from a set of 81 blocks. An 88-piece set in inch units yields combinations in increments 0.000025 inch. The modern abundance of precision low cost mechanisms could not have been achieved without production methods utilizing interchangeable parts, and this, in turn, could not have been achieved without modern precision gaging methods using gage blocks.

NBS master gage blocks are calibrated in the interferometer using either Hg^{198} or a helium-neon-iodine stabilizer. An average of 4,000 master gage blocks are sent to NBS by industry and government each year for calibration or recalibration. During the era of the space race, as many as 100,000 master blocks were received for measurement assurance.

References

- Beers, J. S., A Gage Block Measurement Process Using Single Wavelength Interferometry, Nat. Bur. Stand. (U.S.), Monogr. 152 (1975).
- Pontius, P. E., Measurement Assurance Program--A Case Study: Length Measurements. Part 1. Long Gage Blocks (5 in to 20 in), Nat. Bur. Stand. (U.S.), Monogr. 149 (1975).
- One Ten-Millionth of an Inch, A talk by Dr. I. C. Gardner before the American Ordnance Association (1955).

WORKING STANDARDS OF TEMPERATURE

The International Practical Temperature Scale of 1968 (IPTS-68) is based on values assigned to eleven temperatures that can be reproduced by equilibria between phases of pure substances (defining fixed points). "Standard" thermometric instruments which meet rather stringent requirements are calibrated at these temperatures. Interpolation between the fixed point temperature is provided by specified formulas that relate the indications of the standard thermometric instruments and the values of temperatures of the IPTS-68.

THERMOCOUPLE, PLATINUM-10 PERCENT RHODIUM vs. PLATINUM M522

This is the standard instrument for the IPTS-68 in the range 903.89 K (630.74 °C) to 1337.58 K (1064.43 °C). Such instruments are calibrated at these temperatures and at an intermediate value, 1235.08 K (961.93 °C). This thermocouple is assembled in a sintered alumina insulating tube having two 1.2 mm bores.

PLATINUM RESISTANCE THERMOMETER M523

This is one form of standard IPTS-68 thermometric instrument used from 90.18 K (-182.97 °C) to 903.89 K (630.74 °C), with a "capsule" type for the range from 13.81 to 90.18 K. Nine defining fixed points provide calibration in the platinum resistance thermometer range, one being the triple point of water at 273.16 K.

The standard platinum resistance thermometer (SPRT) design shown consists of a four-terminal resistance coil, approximately 3 cm long and 0.5 cm diameter, on a mica form. The resistance coil and its four leads are hermetically sealed in the borosilicate glass tube (about 7.5 mm o.d. and 50 cm long); the four gold leads emerge at the top through metal-to-glass seals and connect to copper wires. Usually dry air at about one-third of atmospheric pressure is sealed into these thermometers. The instrument is usually measured with a Mueller thermometer bridge, Type G-2 or G-3.

(The upper limit of the borosilicate glass is about 500 °C. For application up to 630.74 °C, a fused silica or Vycor sheath is used and the thermometer leads are usually platinum).

References

- The International Practical Temperature Scale of 1968, *Metrologia* 5, 35 (1969).
- Evans, J. P. and Wood, S. D., An intercomparison of high temperature platinum resistance thermometers and standard thermocouples, *Metrologia* 7, No. 3, 108-130 (July 1971).
- Riddle, J. L., Furukawa, G. T., and Plumb, H. H., Platinum Resistance Thermometry, Nat. Bur. Stand. (U.S.), Monogr. 126 (Apr. 1973).

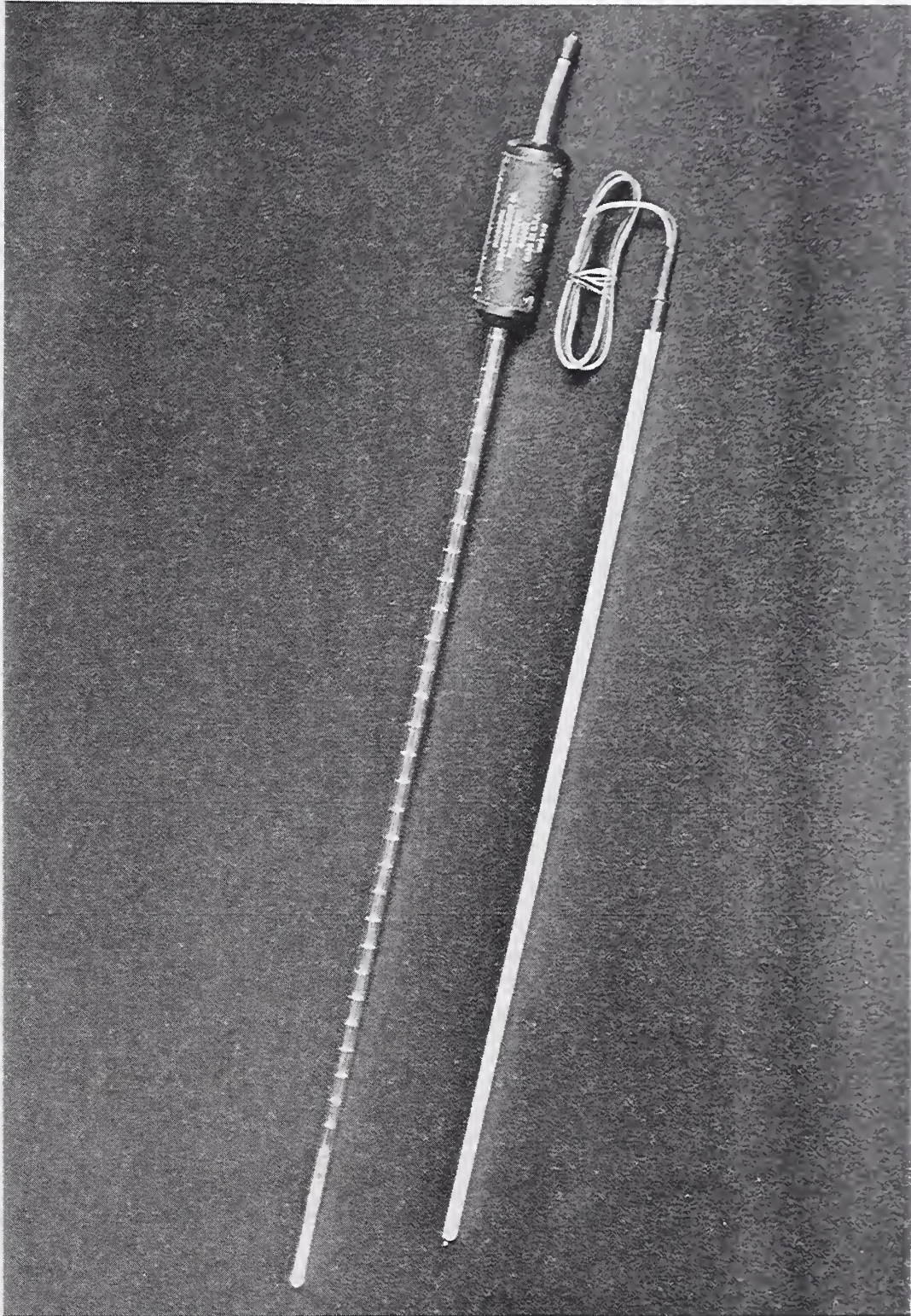

Thermocouple, Platinum vs. Platinum-10 Percent Rhodium M522

Platinum Resistance Thermometer M523

WORKING STANDARD OF FREQUENCY

QUARTZ CRYSTAL RESONATOR

M571

Designed to vibrate millions of times per second at a very stable frequency, quartz crystal resonators are the heart of many modern timepieces. These vibrations function as a "pendulum" for quartz controlled wrist watches and atomic clocks, although a swinging pendulum could never keep pace nor be as accurate as the crystal's stabilized vibrations. A precise 5 MHz, 5th overtone frequency is derived from this working crystal. The physical shape and thickness of a crystal determines its frequency, while its frequency amplitude is determined by the amount of voltage applied to the two flat metallic surfaces coated on the crystal. The crystal is housed in an evacuated glass enclosure. Metal enclosures, backfilled with a protective gas, are also used.

References

Hellwig, H., Frequency Standards and Clocks, A Tutorial Introduction, Nat. Bur. Stand. (U.S.), Tech. Note 616 (Rev. Mar. 1974).

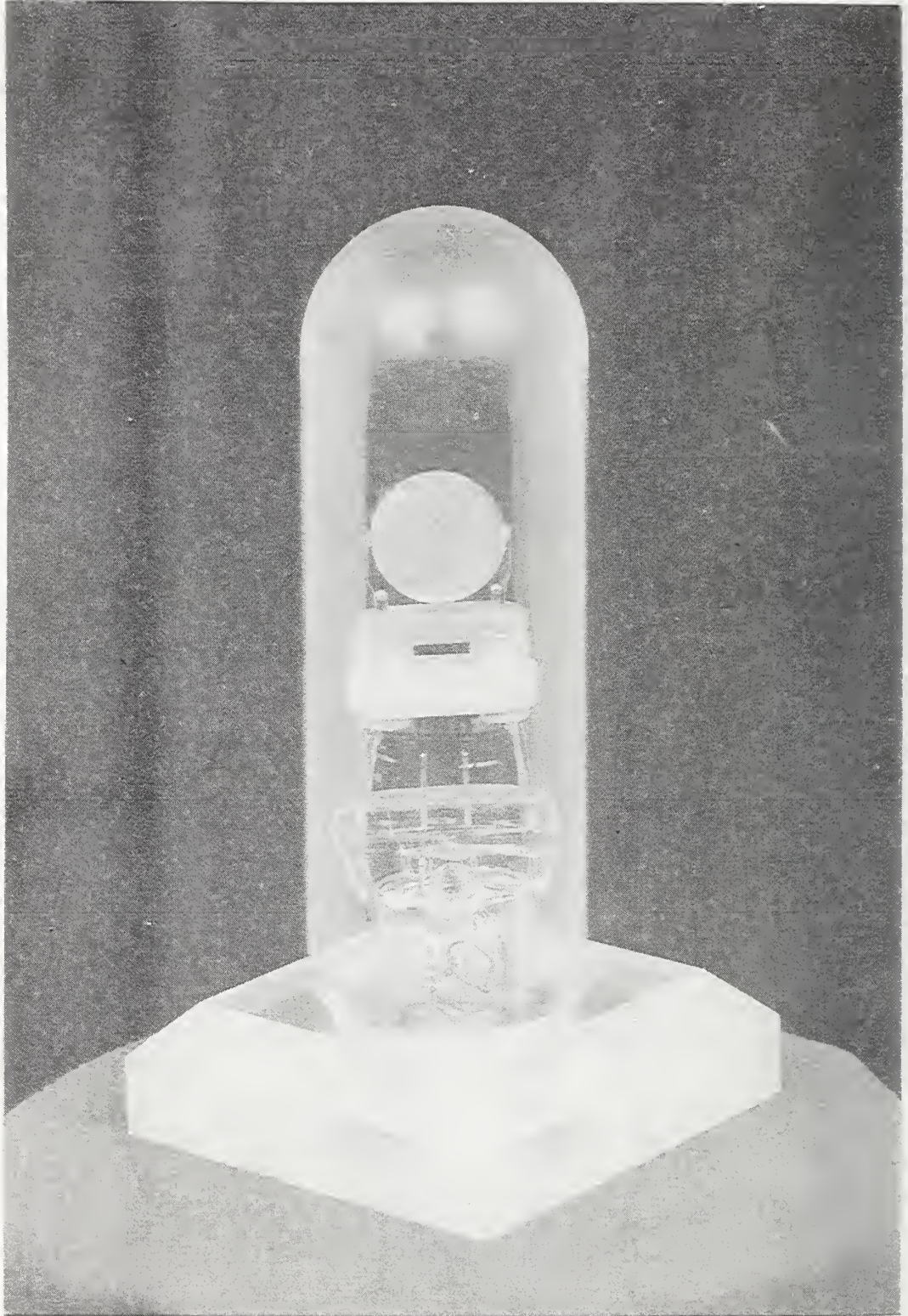

Quartz Crystal Resonator M571

AREA 2 - VAULT

National Standards



FOUR SI UNITS

The International Committee on Weights and Measures, of which the United States has been a member since 1878, currently recognizes seven base units in Le Systè~~m~~e International d'Unités (SI). These are the meter of length, the kilogram of mass, the second of time, the ampere of electric current, the kelvin of thermodynamic temperature, the candela of luminous intensity, and the mole of chemical substance. Four of them--the meter, the kilogram, the second, and the kelvin--are used to define units of measurement for all other physical quantities, whether mechanical, electrical, chemical, optical, thermal, or radio.

Shown here are the national standard of mass (Prototype Kilogram No. 20, under bell jars at right) and representative parts of the equipment used to realize the units for the other three primary quantities. These are (left to right) the krypton-86 lamp for length, the cesium beam oven for time, and the triple-point cell for temperature.

Elsewhere in the museum are displays relating to the ampere, the candela, and the mole; and to many of the derived and supplementary SI units.

References

Page, C. H. and Vigoureaux, P., Eds., The International System of Units, Nat. Bur. Stand. (U.S.), Spec. Publ. 330 (Jan. 1971).

NATIONAL STANDARD OF LENGTH

KRYPTON-86 LAMP

1960

M543

As early as 1829 Babinet proposed defining the meter in terms of the wavelength of light. In 1892 Michelson used his interferometer with cadmium red light, and Barrell has summarized the more precise measurements made in this way between 1892 and 1940. W. F. Meggers at NBS in 1947 developed a source (M274) using the isotope mercury-198, which gives a brilliant green light at room temperature. However, the General Conference on Weights and Measures (CGPM) agreed in 1960 to use a krypton isotope source (M543) operated at 64 K. This is now the U.S. primary standard, replacing the prototype meter bar.

The monochromatic light from this lamp is divided into two beams, each being directed to a mirror from which it is reflected back. The two beams are then recombined. If the distance traveled by the two beams before they are recombined is the same, the waves of light from each will be in phase and will reinforce each other. If one mirror is then displaced along the beam by a quarter wavelength, the waves will interfere destructively. Further motion by a quarter wavelength will again put the two waves in phase. At an observation point in the path, alternate light and dark bands will appear, and the number of times the bands change is a measure of the mirror displacement. The changes may be counted by a photocell, and by the definition adopted by CGPM there are 1 650 763.73 vacuum wavelengths of krypton-86 in one meter.

References

- Michelson, A. A. and Morley, E. W., On the feasibility of establishing a light wave as the ultimate standard of length, *Am. J. Sci.* 38, 181 (1889).
- Cook, H. D. and Marzetta, L. A., An automatic fringe counting interferometer, *Nat. Bur. Stand. (U.S.), J. Res.* 65C (Eng. and Instr.), No. 2 (Apr.-June 1961).
- Page, C. H. and Vigoureux, P., Eds., *The International System of Units (SI)*, *Nat. Bur. Stand. (U.S.), Spec. Publ.* 330, p. 26, 35 (Apr. 1972).

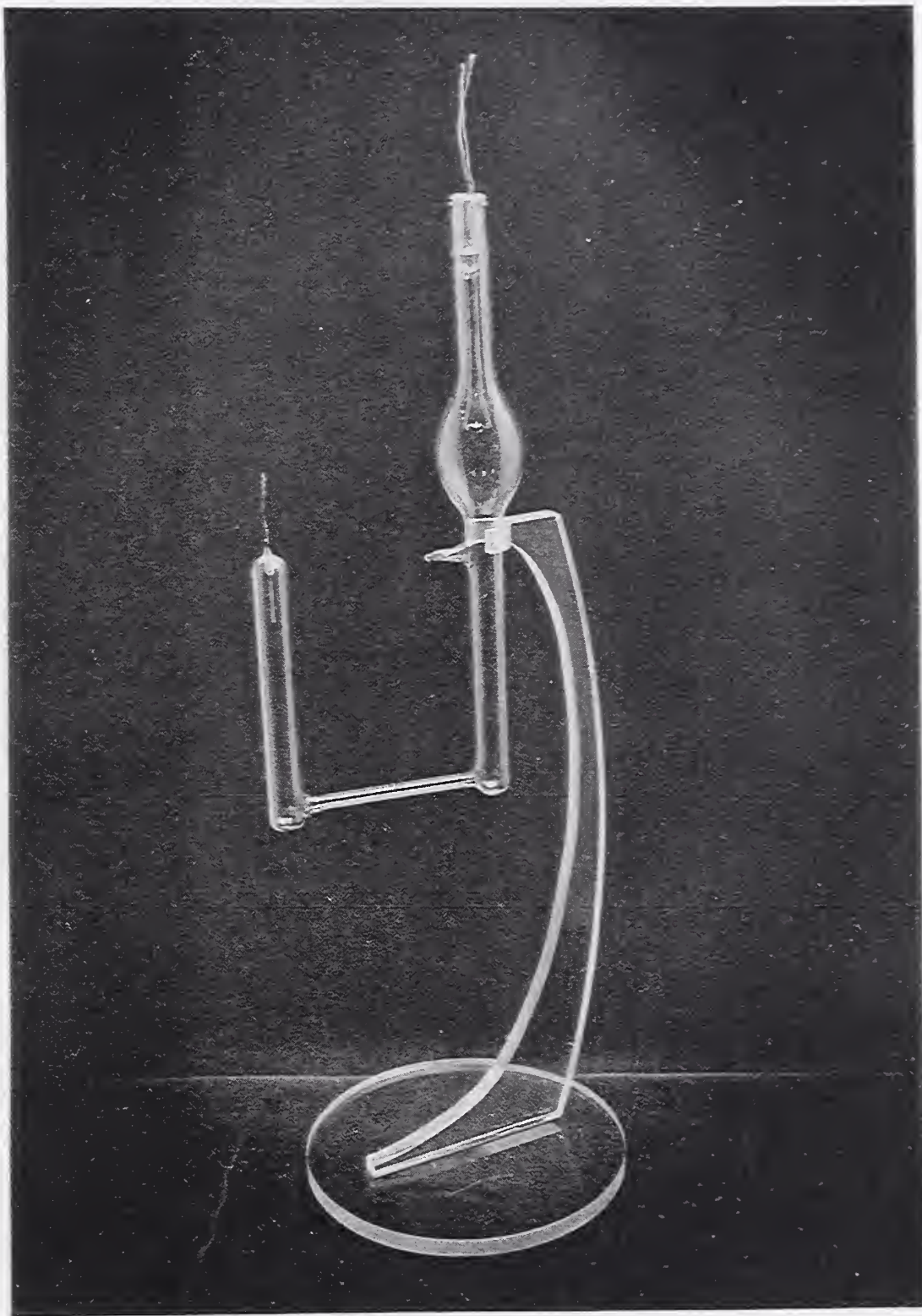

Krypton-86 Lamp (1960) M543

NATIONAL STANDARD OF MASS

After the Treaty of the Meter had been signed in 1875, the International Bureau of Weights and Measures (BIPM) at Sèvres (near Paris) procured 43 prototype kilograms of 90 percent platinum - 10 percent iridium alloy in the form of right circular cylinders of equal diameter and height (approximately 39 mm) with slightly rounded edges.

The volumetric coefficient of expansion of the alloy and the displacement volumes of each of the weights were determined by hydrostatic weighing. One of the group, having essentially the same mass as the Kilogramme des Archives, was selected as the International Prototype Kilogram, and is now maintained at BIPM. The others were either sent to the various member countries as Prototype Kilograms (of which the United States has two) or retained at BIPM for future use.

PROTOTYPE KILOGRAM K²⁰

1889

R5

B. A. Gould, U.S. Delegate to the International Conference of Weights and Measures, himself supervised the packing of Prototype Kilogram K²⁰ on October 27, 1889 for its transport to this country in care of George Davidson of the Coast and Geodetic Survey. On January 2, 1890, President Harrison broke the seals on the case and gave the standard to T. C. Mendenhall, Superintendent of Weights and Measures. Its mass relative to the International Prototype Kilogram was reported as 0.999 999 961 kg. The reported displacement volume at a temperature of 0 °C was 46.402 cm³. Since it was the first of the two prototype kilograms to be received, K²⁰ is sometimes called the national standard of mass. Of the seven base units in Le Système International, the kilogram is the only one currently defined by an artifact.

PROTOTYPE KILOGRAM K⁴

1890

R6

Prototype Kilogram K⁴ was received by the U.S. Coast and Geodetic Survey directly from the International Bureau of Weights and Measures. Its mass relative to the International Prototype Kilogram is 0.999 999 925 kg and its displacement volume at 0 °C is 46.418 cm³.

Since both Prototype Kilograms are in frequent use in the NBS Mass Laboratory, the weights on display are replicas to illustrate the approximate size of the platinum-iridium alloy kilograms. See P. E. Pontius, Mass and Mass Values, NBS Monogr. 133 (1974).

References

Tittman, O. H., National Prototypes of the Standard Metre and Kilogramme, Appendix No. 18 - Report for 1890, U.S. Coast and Geodetic Survey.



Prototype Kilogram K²⁰ (1889) R5
This is a replica. Original in custody of
Mass Standards Laboratory.

INTERNATIONAL STANDARD OF TEMPERATURE

The temperature of the triple point of water (the state of equilibrium between the solid, liquid, and vapor phases) is the single defining fixed point common to the Thermodynamic Temperature Scale and the International Practical Temperature Scale of 1968. It is assigned the value of 273.16 K on both scales.

The triple-point cell (M524) is prepared by cooling the inside of the thermometer well so that water freezes outward from the well and forms a continuous mantle around the well. Usually a mantle of about 4 to 10 mm is frozen. Crushed "dry ice" may be placed directly in the well or a "cold finger" with a suitable heat-conducting fluid may be inserted in the well to freeze the mantle. After freezing the mantle, a very pure ice-and-water interface surrounding the thermometer well is formed by melting a thin layer of ice immediately next to the well. This technique, referred to as an "inner melt," gives a highly reproducible temperature. (The inner-melt temperatures of cells from different sources agree within 0.0002 K.)

It is essential that this inner melt should surround the thermometer well completely. To form the inner melt, the thermometer well is filled with chilled water after a suitable mantle is frozen; then, a glass tube at room temperature is inserted in the well for a period long enough to melt the ice mantle free. When this occurs, the mantle will move free of the well when the cell is given a sudden rotation around its axis.

References

Stimson, H. F., Precision Resistance Thermometry and Fixed Points, pages 133-135 in Precision Measurement and Calibration, Selected NBS Papers on Temperature, J. F. Swindells, Ed., Nat. Bur. Stand. (U.S.), Spec. Publ. 300-2 (Aug. 1968).

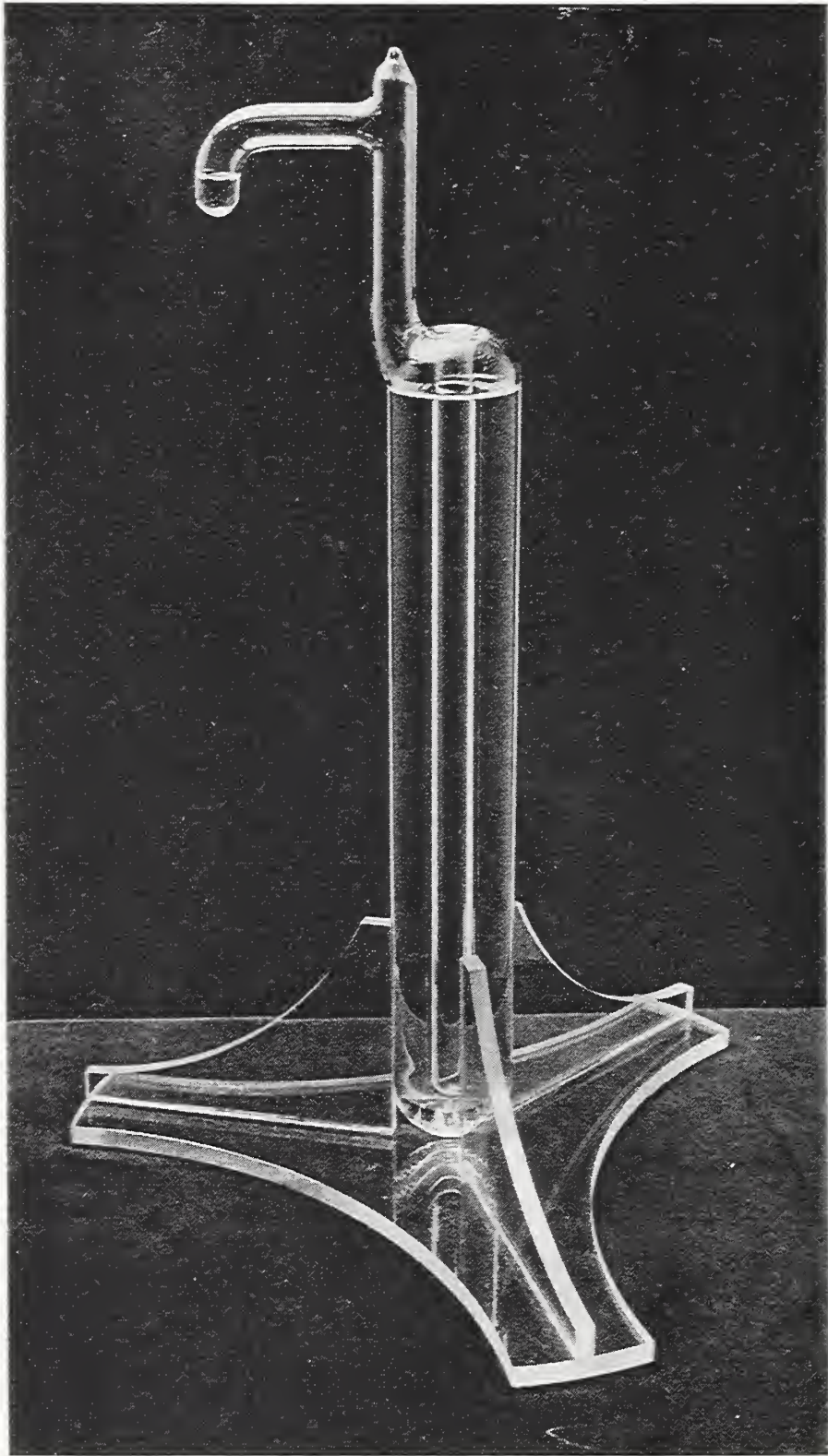

International Standard of Temperature
Triple-Point Cell (1944) M524

NATIONAL STANDARD OF FREQUENCY AND TIME

CESIUM OVEN

1956

M375

In 1967 the International Committee of Weights and Measures declared that the physical measurement of time would be based on a particular transition between energy levels in the atoms of cesium 133. This oven was part of the laboratory frequency standard NBS-II about 1956. In it metallic cesium is heated electrically in a vacuum to about 150 °C. The vaporized atoms effuse through the narrow slit in the front and enter an atomic beam spectrometer about 2 meters long. The beam traverses a steady magnetic field H_A , an oscillating field H_1 , a uniform "C" field with a collimator slit, a second oscillating field H_2 , and a second steady field H_B . These fields act on the magnetic dipole moments of the atoms to effect the desired transition at its natural frequency of 9 192 631 770 Hz (cycles per second), and to establish atomic trajectories which converge toward a detector. The resulting detected beam current goes through a maximum when the frequency of the oscillating fields is swept through the resonance of the cesium transition. A servosystem uses deviations from the maximum to keep the frequency on the cesium resonance.

To provide an atomic time standard, cycles of the frequency as given by NBS-II were counted to give atomic seconds, and these were used to calibrate the seconds of a set of five independent quartz crystal oscillators (similar to M375) each operating continuously as a clock. These oscillator clocks were used to infer the atomic time which NBS-II would have kept had it been running continuously. The time scale so generated was called NBS-A.

References

- Beehler, R. E., Mockler, R. C., and Richardson, J. M., Cesium Beam Atomic Time and Frequency Standards, *Metrologia* 1, No. 3, 114-131 (July 1965); offprinted as pages 95-112 in *Precision Measurement and Calibration, Frequency and Time*, Nat. Bur. Stand. (U.S.), Spec. Publ. 300-5 (June 1972).
- Hellwig, H., *Frequency Standards and Clocks: A Tutorial Introduction*, Nat. Bur. Stand. (U.S.), Tech. Note 616 (Rev. Mar. 1974).

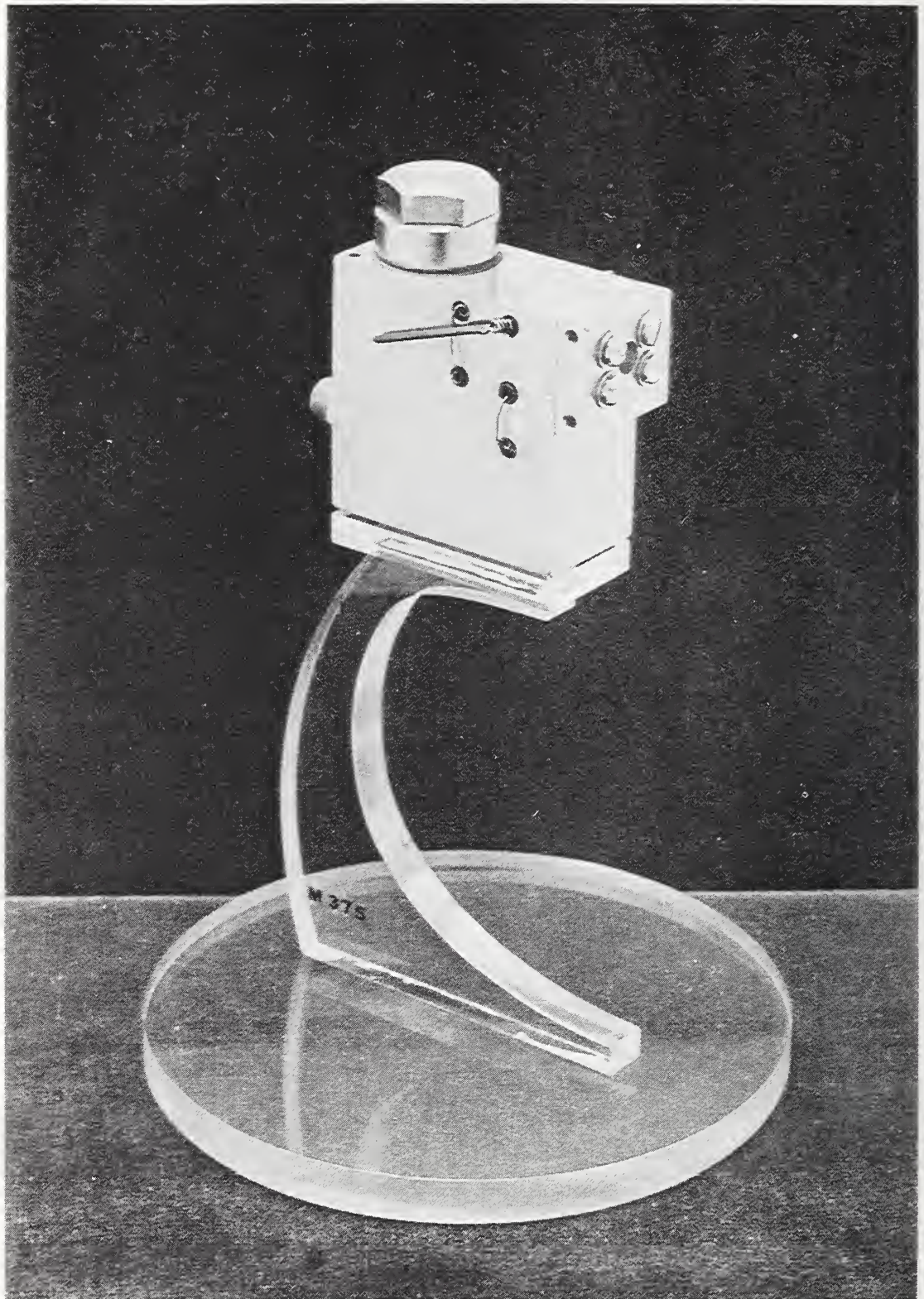

Cesium Oven (1956) M375

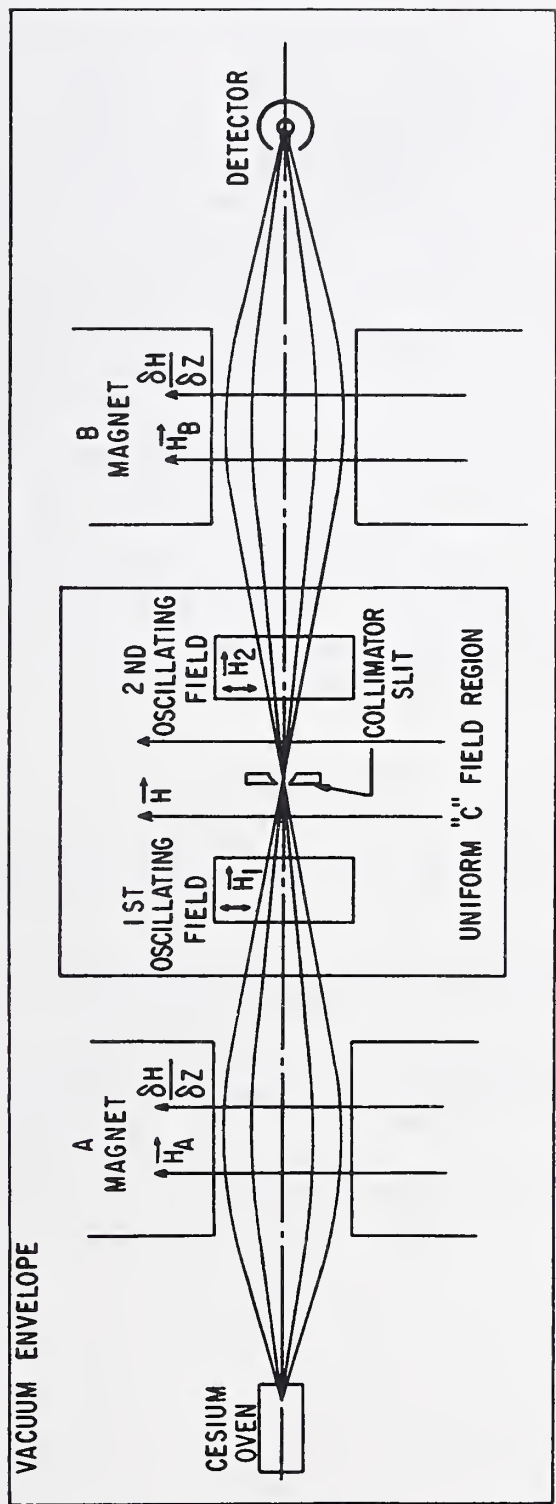

Schematic diagram of beam path of cesium atoms in vacuum chamber of cesium beam frequency standard (1956) M375

NATIONAL STANDARD OF ELECTRICAL RESISTANCE

The International Committee on Weights and Measures (CIPM) voted in 1946 to adopt a system of "absolute" electrical quantities based only on mass, length, and time. The U.S. Congress made this legal in 1949. The British National Physical Laboratory (NPL) derived the absolute ohm by two different methods, the Lorenz rotating inductor and the Campbell mutual inductor. It was derived at NBS in 1938 by H. L. Curtis and associates, using a large self-inductor, and verified in 1949 by J. L. Thomas and associates using the Wenner modification of a Campbell inductor (M41). The experiment involved the construction of an inductor whose value could be computed from its dimensions and the assigned value of space permeability.

In 1956 the Thompson-Lampard theorem in electrostatics made feasible the construction of a calculable capacitor whose configuration is such that only a single length determination is critical. One can compare resistance with a capacitive reactance, knowing the frequency and the permittivity of space. R. D. Cutkosky used this device in 1961, 1967, and again in 1974 to check the value of the NBS unit as maintained by a bank of 1-ohm resistors. The most recent result shows it to be 0.999 999 18 ohms \pm 0.06 ppm.

References

- Glazebrook, R. T., Standards of measurement: Their history and development, Proc. Phys. Soc. 43, Part 4, No. 239 (July 1, 1931).
- Silsbee, F. B., Establishment and Maintenance of the Electric Units, Nat. Bur. Stand. (U.S.), Circ. 475 (June 30, 1949).
- Cooter, I. L., et al., Electrical Standards and Measurements, page 9-1 in Precision Measurement and Calibration, Nat. Bur. Stand. (U.S.), Spec. Publ. 300-3 (Dec. 1968).
- Cutkosky, R. D., New NBS measurements of the absolute farad and ohm, IEEE Trans. Inst. & Meas. IM23, No. 4, 305 (Dec. 1974).

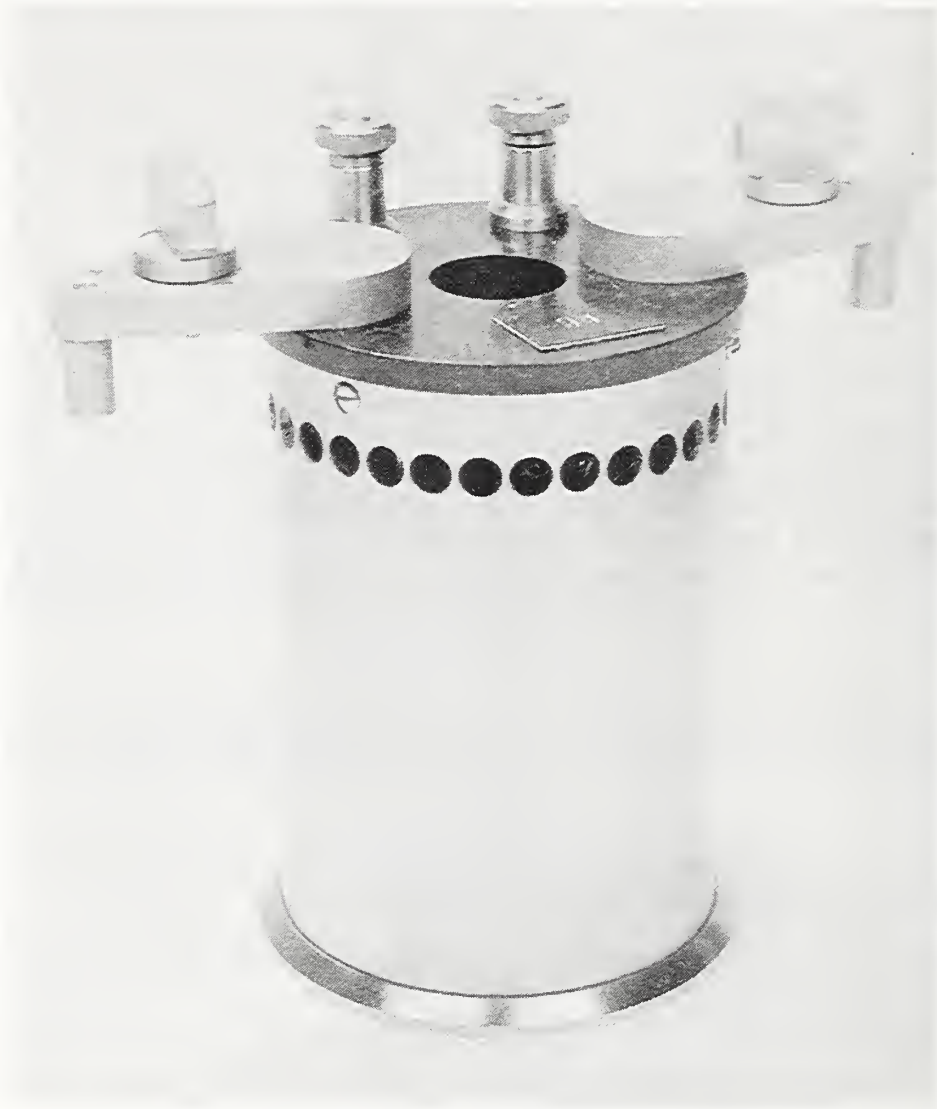

One-Ohm Resistor, Double-Walled (1930) R7

NATIONAL STANDARD OF VOLTAGE

JOSEPHSON JUNCTION

1971

M550

Microelectronic circuit modules like the one displayed have been used since July 1, 1972 as a stable reference for the NBS bank of electrochemical standard cells. The device consists of two superconductor layers separated by a 1 nanometer oxide film. When the module is irradiated at microwave frequencies and cooled to about 1 K in a liquid nitrogen/liquid helium cryostat, electron tunneling across the oxide gives rise to what is known as the ac Josephson effect.

The microwave frequency is related to the voltage applied across the superconductors by the fundamental constant $2 e/h$, where e is the electron charge and h is Planck's constant. For use in maintaining the U.S. legal volt, NBS has adopted the value 483.593 420 terahertz per NBS volt of 1969. Comparisons with the volt standards maintained by National Laboratories in Britain, Australia, and Germany have shown agreement with the NBS volt to within 1 or 2 parts in 10^7 .

References

- Field, B. F., Finnegan, T. F., and Toots, J., Volt maintenance at NBS via $2 e/h$: A new definition of the NBS volt, *Metrologia* 9, 155 (1973).
- Finnegan, T. F., Denenstien, A., Langenberg, D. N., *Phys. Rev. B* 4, 1487 (1971).
- Parker, W. H., Langenberg, D. N., Denenstien, A., Taylor, B. N., *Phys. Rev.* 177, 639 (1969).
- Taylor, B. N., Parker, W. H., Langenberg, D. N., Denenstien, A., *Metrologia* 3, 89 (1967).

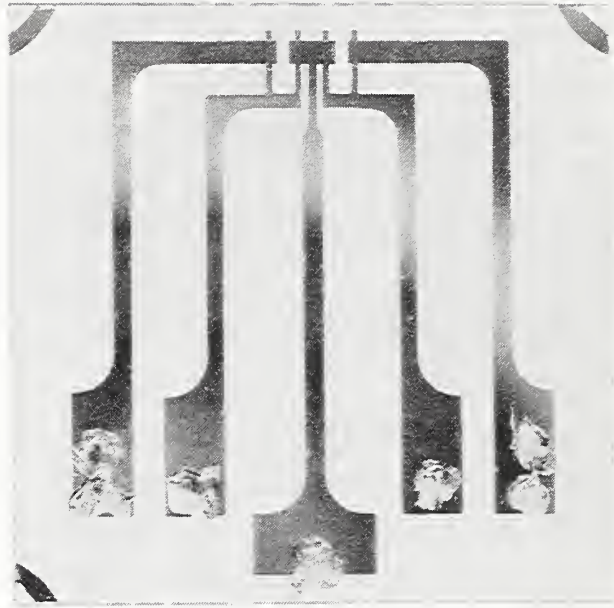

Josephson Junction (1971) M550

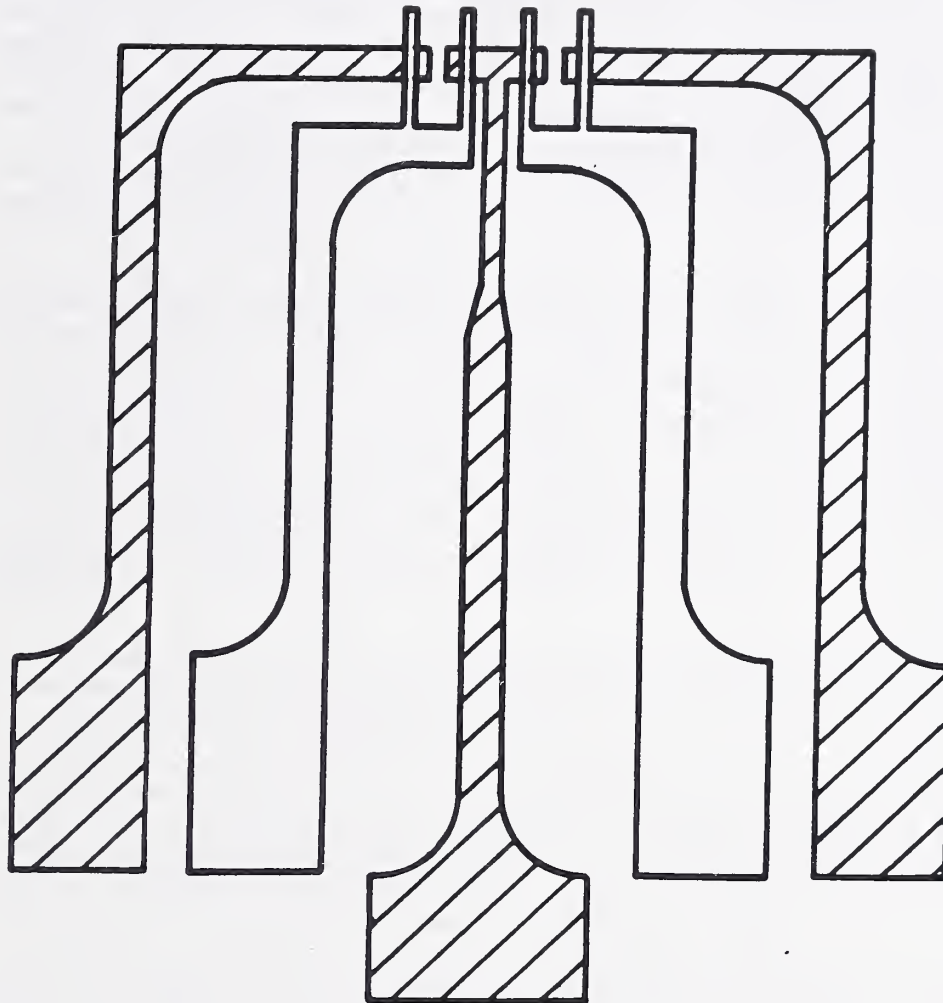

0 5 10mm

Josephson-device geometry (1971) M550

The cross-hatched region indicates the oxidized film which is partially covered by the second film to produce four junctions.

INTERNATIONAL STANDARD OF LIGHT

PLATINUM BLACKBODY

1930

M197

The French physicist Violle in 1881 proposed as a primary standard of luminance the light emitted by 1 sq cm of surface of melted platinum at the temperature of its solidification, about 2045 K. However, studies by Waidner and Burgess of NBS showed that a variation of one degree caused a variation of over 0.5 percent in the intensity of the light. They suggested the use of a blackbody (one which completely absorbs all radiation incident upon it) with the important feature that it be totally immersed in a bath of freezing platinum.

When Wensel and his coworkers undertook to realize the Waidner-Burgess concept, they used as the blackbody a few grams of fused thoria placed at the bottom of a sight tube and viewed through a 1.5 mm opening. Molten platinum of exceptionally high purity (simulated by lead in the cut-away model M197 on display) was contained in a thoria crucible, and uniformity of temperature was achieved by the violent stirring which resulted from heating in a high frequency induction furnace. In terms of the "international candle," maintained at NBS since 1909 by a group of carbon-filament lamps (M198), the luminance was found to be $58.84 + 0.20$ or -0.09 c/cm².

By 1933 the Comité International des Poids et Mesures had appointed a photometry committee and accepted both the blackbody concept and the freezing platinum reference.

The national laboratories of France, Great Britain and the United States agreed in 1937 that a standard platinum blackbody represented 58.9 international candles per square centimeter, and in 1946 CIPM adopted the figure of 60 c/cm². The name "candela" was adopted for the unit of luminous intensity in 1948.

Besides serving as the basis for the photometric system of units, the platinum blackbody standard will make it possible to determine (by the use of Planck's equation and the spectral luminous efficiency values of the Commission Internationale de l'Eclairage) the "mechanical equivalent of light" which will be useful when the blackbody standard is eventually superseded by a radiometric method for defining the unit of light.

References

- Violle, J., Sur l' etalon absolu de lumiere, Ann. Chem. et Phys. (6) 3, 373-407 (1884).
- Waidner, C. W. and Burgess, G. K., The Radiation from and the Melting Points of Palladium and Platinum, Bull. Nat. Bur. Stand. 3, 163-208 (1907).
- Waidner, C. W. and Burgess, G. K., Note on the Primary Standard of Light, Electrical World LII, No. 12, 625-628 (1908).
- Wensel, H. T., Roeser, W. F., Barbrow, L. E., and Caldwell, F. R., The Waidner-Burgess Standard of Light, Nat. Bur. Stand. (U.S.), J. Res. 6, 1105-1117 (1931).
- Announcement of Changes in Electrical and Photometric Units, Nat. Bur. Stand. (U.S.), Circ. 459 (May 1947).

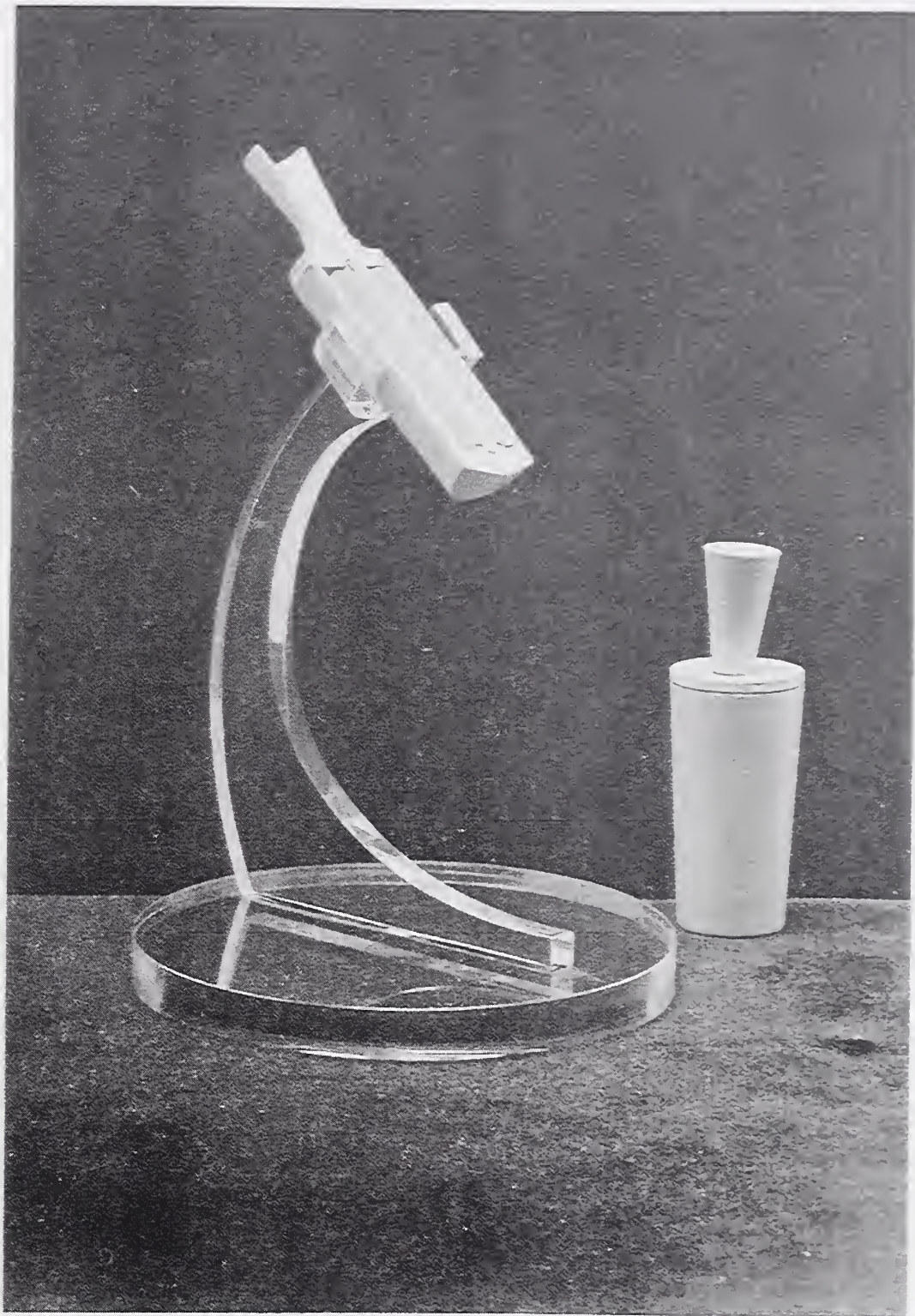

Platinum Blackbody (1930) M197

AREA 3 - VAULT

Historical Standards



HISTORICAL CUSTOMARY STANDARDS OF MASS

TROY POUND

1827

M446

The troy ounce (named for Troyes in France) has been used for the sale of gold, silver and precious stones from 1527 to the present. The troy pound is subdivided into 12 ounces, each of which in turn is subdivided into 480 grains for a total of 5760 grains. To standardize weights of U.S. coinage in 1827, plenipotentiary Albert Gallatin procured for the Philadelphia Mint a troy pound reported to be an "exact copy" of the British standard, the Imperial Troy Pound of 1758. It was a two-piece unplated brass weight, engraved "Pound Troy, 1824, Bate, London." The troy pound on display (M446) is a later copy which proved to be unstable and so was rejected.

"STAR" AVOIRDUPOIS POUND

1830

M323

Both the British and the U.S. avoirdupois pounds widely used in commerce, are subdivided into 16 ounces each of which is further subdivided into 480 grains for a total of 7,000 grains. Each country derived the avoirdupois pound from the troy pound through the ratio 7,000/5760. The cylindrical brass weight displayed (M323) is marked on the top surface of the knob with a star. Although positive identification cannot be made, it appears not unreasonable to assume that this standard is the actual weight "made by Mr. Hassler from the troy pound in the United States Mint, and marked with a star (commonly designated as the star pound)," as referred to by A. D. Bache, Superintendent of Weights and Measures, in his report of December 30, 1856, to the Secretary of the Treasury.

IMPERIAL AVOIRDUPOIS POUND,
Copy No. 5

1856

M324

A gold-plated brass standard of mass, cylindrical in form, with a circumferential groove instead of a knob to facilitate its handling. In 1834 the Imperial Troy Pound of 1758 was destroyed by fire. Using two platinum troy pounds which had been carefully compared with the lost standard, Prof. W. H. Miller of the British Standards Commission constructed a new platinum troy pound and from that a new platinum imperial avoirdupois pound. As a part of this work, gilded bronze copies were distributed to English-speaking nations, and copy No. 5 (M324) was received here in 1856 as a gift from Great Britain to the United States. It was reported that Hassler's "star" pound agreed with this copy within 0.001 grain, or 1 part in 7×10^6 --a truly remarkable achievement.

Comparisons between the two platinum weights and the Kilogram of the Archives have provided the basis for the currently accepted relation:

1 avoirdupois pound = 0.453 592 37 kilogram.

References

Chisholm, H. W., On the Science of Weighing and Measuring, (Macmillan, London, 1877).

Judson, L. V., Weights and Measures Standards of the United States, Nat. Bur. Stand. (U.S.), Misc. Publ. 247 (1963).



Troy Pound (1827) M446



"Star" Avoirdupois Pound (1830) M323



Imperial Avoirdupois Pound, Copy No. 5 (1856) M324

HISTORICAL METRIC STANDARDS OF MASS

1 GRAVE

1793

M322

A cylindrical knob weight, one of six made in 1793 by the French Temporary Commission on Weights and Measures as representing the unit of weight of a proposed system of weights and measures. Originally called the "grave," in 1795 the unit was renamed the "kilogram." This weight is from a set of weights brought to the United States in 1793, and it appears that the set came into the possession of one Andrew Ellicott, at one time an assistant to Major Pierre Charles L'Enfant who planned the city of Washington. The subsequent history of this set of weights is somewhat obscure, but it seems probable that the set remained in private hands, probably within the Ellicott family until 1952, when what remained of the set was donated to the National Bureau of Standards by its owner at that time, Dr. A. Ellicott Douglass of the University of Arizona.

References

Judson, L. V., *Weights and Measures Standards of the United States*, Nat. Bur. Stand. (U.S.), Misc. Publ. 247 (1963).

KILOGRAM/LITER

1791

M448

A hollow gold-plated brass sphere having a mass of approximately 1 kg and a volume of approximately one cubic decimetre. It was thus a physical object having the properties of a kilogram of pure water free from air. This was the first concept for the definition of the metric unit of mass, and the original experiments to achieve this "kilogramme provisionaire" were reported to the Academy of Paris in 1791. The idea had to be abandoned because the precision of weighing, with due regard for the buoyancy of the air, was much better than that with which the water kilogram could be reproduced.

The sphere on display was constructed by Louis A. Fischer of NBS about 1905 to replace one believed to have been made about 1844 by Joseph Saxton of the U.S. Coast Survey. Records in the National Archives indicate that the Saxton sphere was found to leak air.

References

Letter, Lloyd B. Macurdy, November 15, 1973.

A brass standard of mass of cylindrical form with a knob. This standard is one of a group of similar standards made in France in 1799 by the Committee that made the Kilogram of the Archives, whence its designation in the United States as the "Committee Kilogram." This standard was presented by Trallès, the Swiss member of the Committee, to his friend F. R. Hassler in 1805. Hassler, in turn, sold it to a member of the American Philosophical Society in Philadelphia, who deposited it with the Society. Later, the standard was obtained from the Society by Hassler, who made use of it in connection with his standards work for the U.S. Coast and Geodetic Survey.

SILBERMANN KILOGRAM

1852

M321

A gold-plated brass standard of mass of cylindrical form with a knob. This standard was presented to the United States by France in 1852. It was used in the Office of Standard Weights and Measures of the U.S. Coast and Geodetic Survey, particularly in connection with the adjustment and verification of the early metric standards supplied to the States.

References

Judson, L. V., Weights and Measures Standards of the United States, Nat. Bur. Stand. (U.S.), Misc. Publ. 247 (1963).



1 Grave (1793) M322



Kilogram/Liter (1791) M448



Committee Kilogram (1799) M319



Silberman Kilogram (1852) M321

HISTORICAL STANDARDS OF ELECTRIC CURRENT

The silver voltameter, better called a coulometer, was chosen as the official primary standard for the measurement of current by the International Electrical Congress at Chicago in 1893. When a silver anode is suspended in a platinum container of electrolyte, the passage of current deposits crystals of pure silver on the platinum cathode. The principle was used by Poggendorff in 1847. In a systematic study of the device made by Lord Rayleigh in 1884, the anode was wrapped in filter paper to catch the particles of silver slime which might contaminate the deposit (M172). Another form used by F. and W. Kohlrausch and described in 1886 had no septum, but a small glass dish was hung below the anode (M175). Richards and Heimrod in 1899 substituted a porous cup of porcelain for the filter paper (M170). In 1906, F. E. Smith devised a "new form" (M171) in which the disc-shaped anode rests in a shallow glass cup. A movable glass ring, with its lower edge ground to fit the cup, is supported above the cup during the experiment. Its lower edge is below the electrolyte surface, to prevent any floating slime from reaching the outer vessel. At the end of the experiment the ring is lowered onto the cup, and the cup and ring assembly containing the anode and anode slime is removed before the platinum cathode is emptied and weighed.

The London Conference of 1908 adopted specifications for the mercury ohm and the Weston Normal cell, and defined the international ampere as "the unvarying electric current which, when passed through a solution of nitrate of silver in water ... deposits silver at the rate of 0.00111800 of a gramme per second." At the National Physical Laboratory, F. E. Smith made careful determinations of the electrochemical equivalent of silver using several forms of voltameter, and at the Reichsanstalt, W. Jaeger used the porous cup form and another without septum. At NBS, E. B. Rosa and associates began intensive work in 1908 which showed that the filter paper was a source of serious disturbance in the character and weight of the deposit.

Meanwhile, arrangements had been made for Smith, Jaeger, and L. Laporte of the Laboratoire Centrale d'Electricité to meet at NBS as a Special Technical Committee, with Rosa as chairman. They began work in April 1910, using pure electrolytes, and three voltameters - the new form of Smith (M171), a 100 cc size of Richards (M170) and a 300 cc size of Richards. The relative masses of the deposits were respectively 1.00000₀, and 0.99997₇, and 1.00000₉. Further experiments by Smith and Vinal, and by Rosa, Vinal and McDaniel showed agreement within 4 parts in 100,000. A complete specification for materials and procedures was later prepared by the U.S. team.

The classic experiment of Rosa, Dorsey, and Miller in 1910 provided a relation between an international ampere determined by coulometer and an absolute ampere determined by the forces in a current balance such as M69. In 1948 the international ampere was defined as 0.99985 absolute ampere.

References

Rosa, E. B. and Vinal, G. W., The Silver Voltameter - Part I, Bull. Nat. Bur. Stand. 9, 151 (1913); Summary of Experiments, Sci. Pap. Nat. Bur. Stand. No. 285 (1916).

Rosa, E. B., Vinal, G. W., and McDaniel, A. S., The Silver Voltameter - Part II, Bull. Nat. Bur. Stand. 9, 209; Part III, 493; Part IV *ibid* 10, 475 (1914).

Glazebrook, R. T., Dictionary of Physics 2, p. 247, Macmillan, London (1922).

Report to the International Committee on Electrical Units and Standards, U.S. Government Printing Office, Washington, D.C. (Jan. 1, 1912).

Richards, T. W. and Heimrod, G., On the accuracy of the improved silver voltameter, Proc. Am. Acad. Sci. 37, 415 (1902).

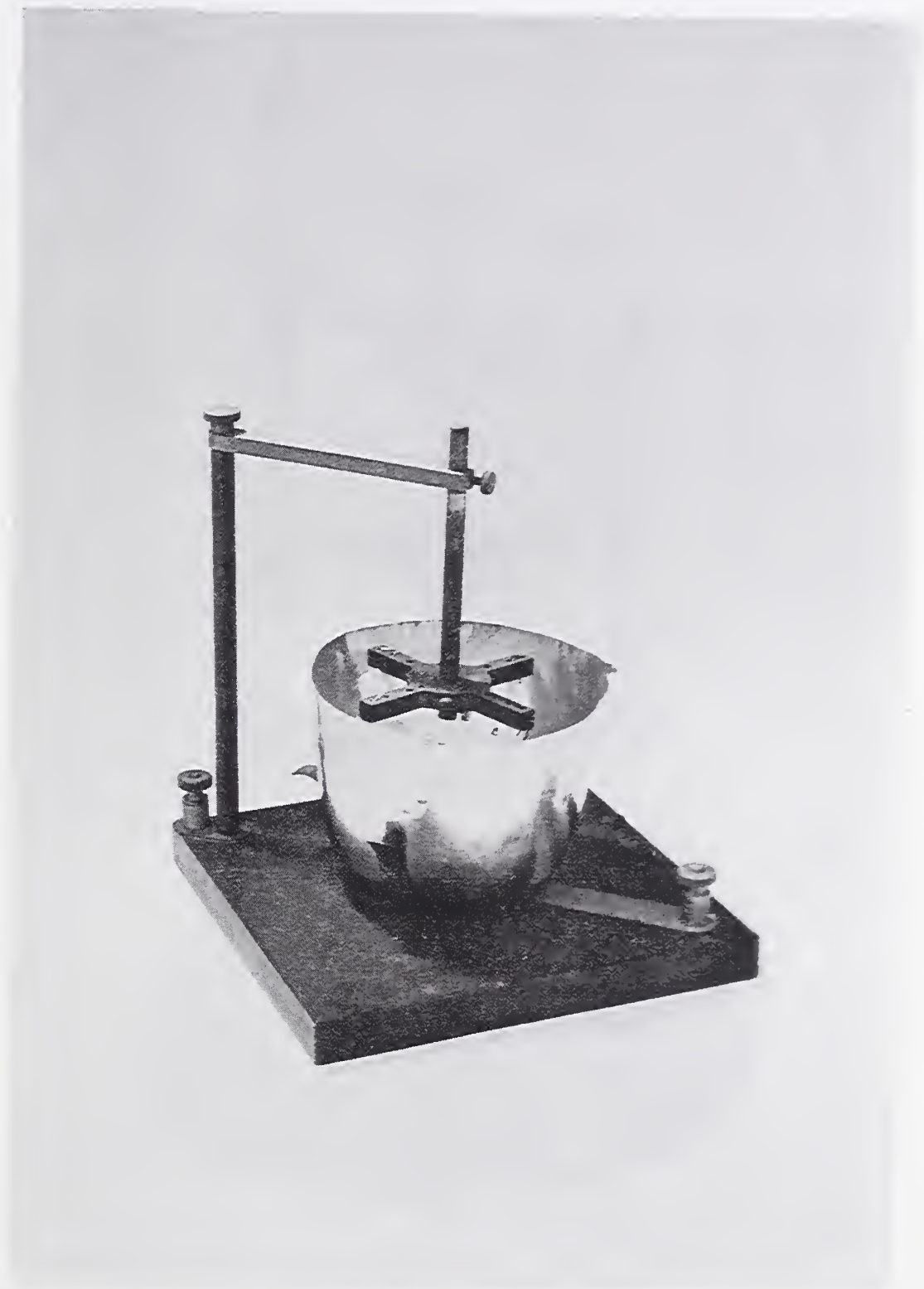

Coulometer, Rayleigh (England) (1884) M172



Coulometer, Kohlrausch (Germany) (1910) M175

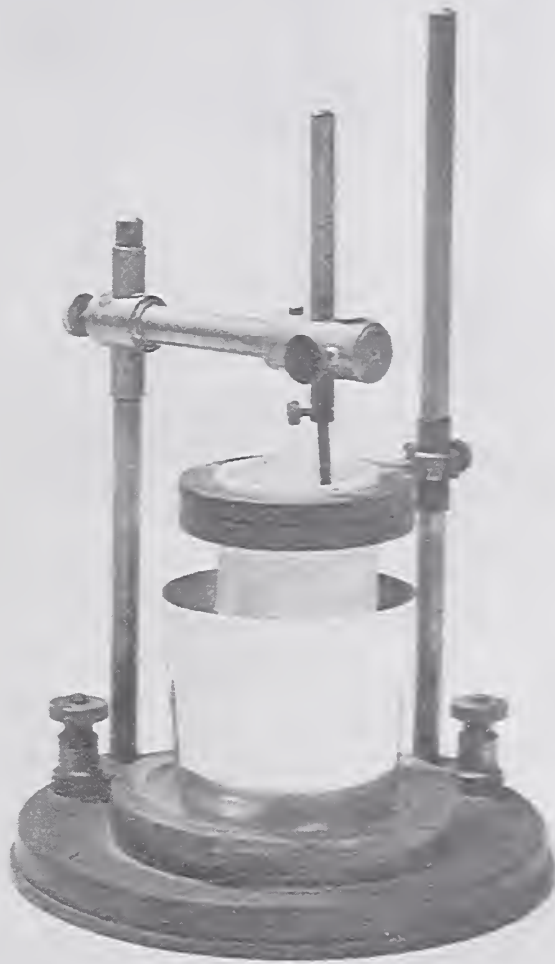

Coulometer, Richards (United States) (1910) M170

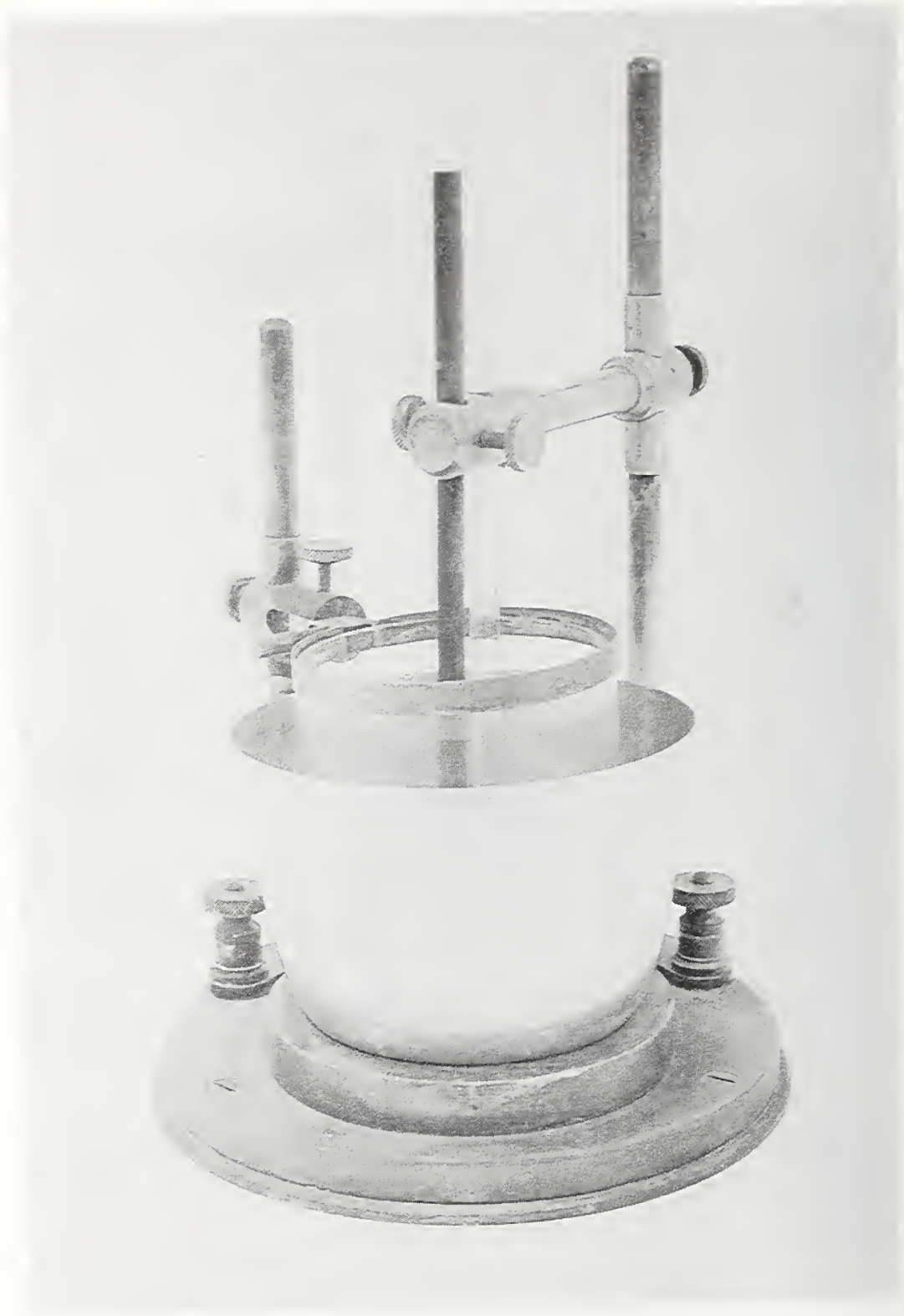

Coulometer, Smith (England) (1910) M171

HISTORICAL STANDARDS OF ELECTRICAL RESISTANCE

In 1861 the British Association for the Advancement of Science appointed a committee for improving the construction of practical standards of electrical measurements. To specify resistance, they constructed in 1863 and 1864 wire-wound resistors known as the B. A. ohm; M51 is of this design. These resistors were manufactured and used over the next couple of decades. However, because of the instability of the resistors they were replaced as primary standards by the "international ohm" defined in the 1880's as the resistance of a specified column of mercury at a specified temperature. This unit was legalized in the United States in 1894. The precise specification adopted by the London Conference of 1908 called for a mass of 14.4521 g at 0 °C, a length of 106.300 cm and a uniform cross section of about 1 mm². In the late 1880's the German Physikalisch-Technische Reichsanstalt (PTR) designed a resistor which is known as the PTR type (M334). These were the first resistors to use manganin wire and were designed so that the coil of insulated wire would be in direct contact with the oil of the bath in which it was placed.

In this country, a group of wire resistors of the PTR pattern, made in Berlin and certified by the PTR, formed the national reference standard up to 1907. E. B. Rosa and H. D. Babcock at NBS had noted that these changed value seasonally, and traced the trouble to the effect of atmospheric humidity. In the design which Rosa then developed (M28) the coil was sealed in a container of very pure dry oil. Between 1911 and 1913, F. A. Wolff and associates at NBS constructed four mercury ohm tubes (M137) to the international specification, and used them to verify five Rosa coils. A group of resistors of the Rosa type was used to maintain the unit of resistance in the USA until they were replaced in the 1930's by a type of resistor designed by J. L. Thomas of NBS. In the Thomas-type resistor (R7, M42) a bifilar manganin coil is formed and heated to red heat in a vacuum before being sealed in dry air between two tubular shells soldered together at their ends. The coil of wire is only loosely in contact with the inner shell. Since 1930 a group of the Thomas 1-ohm resistors has constituted the U.S. reference standard, being intercompared periodically with other national laboratories.

References

- Glazebrook, R. T., Standards of measurement: Their history and development, Proc. Phys. Soc. 43, Part 4, No. 239 (July 1, 1931).
- Silsbee, F. B., Establishment and Maintenance of the Electrical Units, Nat. Bur. Stand. (U.S.), Circ. 475 (June 30, 1949).

This standard resistor, made by Elliott Bros., London, was presented in 1887 by the (British) Institution of Electrical Engineers as a Fahie Premium to A. E. Kennelly (then an associate member) as an award for his paper on "Certain Phenomena Connected with the Imperfect Earth in Telegraph Circuits." It was calibrated at the Cavendish Laboratory as Test No. 193 on March 13, 1896, and certified by R. T. Glazebrook as $R = 1.00028$ legal ohms at $16.9\text{ }^{\circ}\text{C}$ with the statement "1 legal ohm = 1.0112 BA units." It was apparently given to NBS by Professor Kennelly about 1930. When measured at $25\text{ }^{\circ}\text{C}$ by C. Peterson in 1962, in terms of the ohm as then maintained by NBS, its value was found to be 0.999 950 ohms.

ONE-OHM RESISTOR, PTR

1898

M334

This type of the International Ohm, developed by the Physikalisch-Technische Reichsanstalt (PTR), was the first to use manganin wire and was so designed that the insulated coil would be directly in contact with the oil of the bath in which it was placed. Serial 1403, made by O. Wolff of Berlin, was presumably purchased by the Coast Survey and turned over to NBS in 1901. Originally a 2-terminal standard, definite potential terminals seem to have been added later. It was retested at PTR in about 1906 and "carried the ohm" from Potsdam to Washington to establish the U.S. reference standard in 1907. The NBS design of E. B. Rosa (M28) subsequently replaced it.

ROSA OHM

1907

M28

In this type of standard resistor, the coil of manganin wire is wound on a cylinder 30 mm in diameter, then shellacked, dried, and annealed as specified by the PTR. The outer case 40 mm in diameter was filled with pure dry oil, and the hard-rubber top screwed on after the threads had been shellacked. This type was used for primary reference standards of 1 ohm and above from 1908 to 1930. However, the sealing was difficult to maintain, and for use at the highest precision, was replaced in 1930 by the Thomas double-walled type at the 1-ohm level.

References

Rosa, E. B., A New Form of Standard Resistance, Bull. Nat. Bur. Stand. 5, 413 (1908-09).



B.A. Ohm (1887) M44



One-Ohm Resistor, PTR (1898) M334



Rosa Ohm (1907) M28

The prototype mercurial standard resistor by which the International Ohm (the official unit of electrical resistance from 1908 to 1948) is defined, consists of a column of mercury of specified length, mass and temperature. One of these glass tubes, fitted with axial current leads, served to contain the mercury, and could be immersed in an ice bath. A small theoretical correction was applied for the effective resistance in the bulbs at either end which carry the potential leads.

Tubes of this group were used in 1911 and 1912 in independent measurements to verify the values assigned in 1910 to the NBS Rosa ohms, which at that time were the national reference standards of resistance, on the basis of the international intercomparisons then made at NBS by the International Committee on Electrical Units and Standards.

References

Report to the International Committee on Electrical Units and Standards, Nat. Bur. Stand., U.S. Government Printing Office (Jan. 1, 1912).

Wolff, F. A., Shoemaker, M. P., and Briggs, C. A., Construction of Primary Mercurial Resistance Standards, Bull. Nat. Bur. Stand. 12, 375 (1915-16).



Mercury Ohm Tube (1911) M137

HISTORICAL STANDARDS OF ELECTROMOTIVE FORCE

In 1893 the International Electrical Congress chose as a practical standard for electromotive force (emf) an electrochemical cell devised by L. Clark (M280, M279) which was assigned a value of 1.434 volts at 15 °C. This value was derived from the Ohm's law relation, volt = ampere x ohm, the latter units having been already realized. It was legalized in the United States on July 12, 1894. However, between then and 1905 the Weston saturated cadmium sulfate cell (M281) was found to have many advantages. To reach agreement on its precise emf, scientists from England, France, and Germany met at NBS in 1910, with E. B. Rosa of NBS as chairman. As a result of their experiments with a number of resistors, silver coulometers, and Weston standard cells, they adopted 1.0183 as the emf of a Weston Normal Cell at 20 °C, in terms of an international volt. New determinations of the ampere and the ohm led to a value expressed in absolute volts and then adopted in 1948. This value became 1.018 328 6 volts by international agreement in 1969.

References

- Glazebrook, R. T., Standards of measurement: Their history and development, Proc. Phys. Soc. 43, Part 4, No. 239 (London, July 1931).
- Hamer, W. J., Standard Cells: Their Construction, Maintenance, and Characteristics, Nat. Bur. Stand. (U.S.), Monogr. 84 (1965).
- Field, B. F., Finnegan, T. F., and Toots, J., Volt maintenance at NBS via 2 e/h: a new definition of the NBS volt, Metrologia 9, 155-166 (1973).

This Clark standard cell, of the Fuessner type with zinc and mercury-mercurous sulfate electrodes, was manufactured by Hartmann and Braun, Frankfort A/M Germany. It had been certified by the PTR in 1896, presumably for the Office of Weights and Measures, and was taken over by NBS in 1901. The cell is enclosed in a brass case which is filled with a white powder, presumably to absorb liquid in case of leakage and to improve thermal stability. The U.S. national standard of emf was originally maintained by a group of Clark cells from 1906 to 1910.

References

Clark, L., On a standard voltaic battery, Phil. Trans. Roy. Soc. 164, p. 1 (1874).



Clark Standard Cell (1896) M279

This standard cell, No. 88, is of the Carhart-Clark (unsaturated) type with zinc and mercury-mercurous sulfate electrodes one above the other in a single tube. It was manufactured by Queen & Company of Philadelphia.

References

Clark, L., Proc. Roy. Soc. 20, 444 (London, 1872).

Carhart, H. S., Phil. Mag. 28, 420 (1889).



Carhart-Clark Standard Cell (1889) M280

This unsaturated cadmium sulfate standard cell, No. 508, was manufactured by the European Weston Electric Instrument Company, GmbH Berlin. It was probably purchased by the Office of Weights and Measures and transferred to NBS when it was established in 1901.

References

The Weston Standard Cell, *The Electrician* 30, 742 (London, 1893).

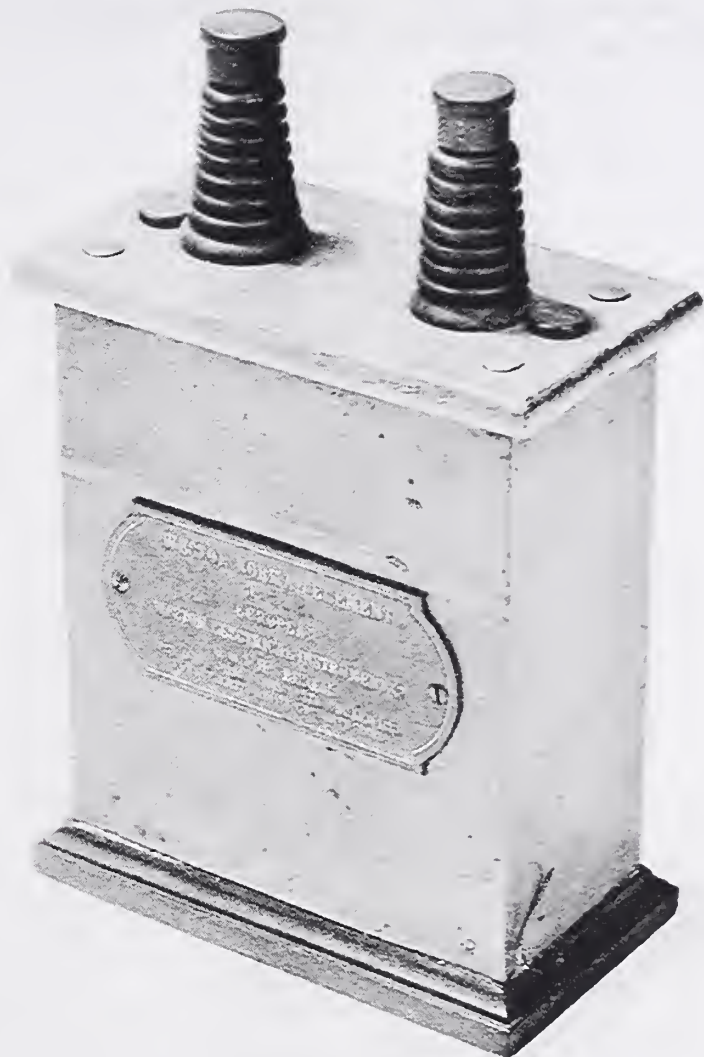

Weston Standard Cell (1901) M283

This saturated cadmium sulfate standard cell, No. 386, was one of a group made at NBS in 1910 for experimental purposes. The inverted Y shape of the container had been suggested by Wright and Thompson, and the use of the ground stopper by Kahle.

References

Wright, C. R. A. and Thompson, C., *Phil. Mag.* V 16, 28 (1883).

Kahle, K., Instructions for preparing Clark standard cells, *The Electrician* 31, 265 (London, 1893).

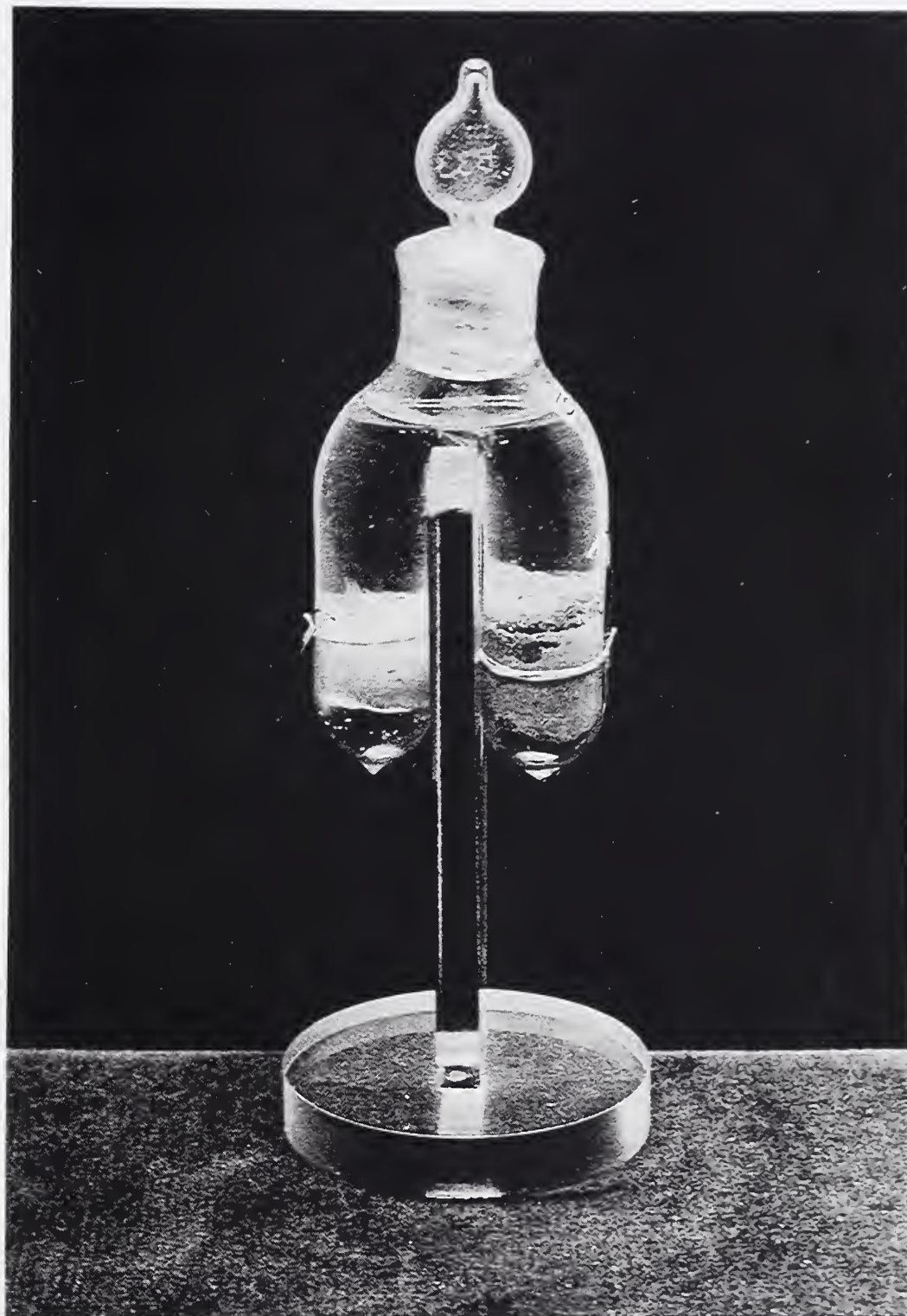

Kahle Standard Cell (1910) M282

HISTORICAL STANDARD OF FREQUENCY

QUARTZ OSCILLATOR
Marrison Type

M373

Within the cylindrical casing is a toroidal plate of quartz, which will resonate at 100,000 Hz (cycles per second) when it is point-supported on a horizontal plug through its center and excited by an external vacuum-tube oscillatory circuit in series. The quartz must be carefully selected, and there must be careful control of ambient temperature, pressure, and humidity. The continuous oscillation of any one of three such units (with a fourth as check) can be fed to a frequency dividing circuit and used to drive a synchronous motor which in turn is geared to a clock.

This piezoelectric system formed part of the national standard reference group from 1929 until 1950. It was possible to obtain accurate time intervals of any length desired, from about one microsecond up to several hours.

References

- Marrison, W. A., A high precision standard of frequency, Proc. IRE 17¹, 1103-1122 (1929).
- Hall, E. L., Eaton, V. E., and Lapham, E. G., The National Primary Standard of Frequency, Nat. Bur. Stand. (U.S.), J. Res. 14, 85, RP759 (Feb. 1935).
- Hellwig, H., Frequency Standards and Clocks: A Tutorial Introduction, Nat. Bur. Stand. (U.S.), Tech. Note 616 (Rev. Mar. 1974).
- Lyons, H., The Atomic Clock, Nat. Bur. Stand. (U.S.), Tech. News Bull. 33, 17 (Feb. 1949) describes microwave signal controlled by ammonia absorption frequency driving quartz oscillator.

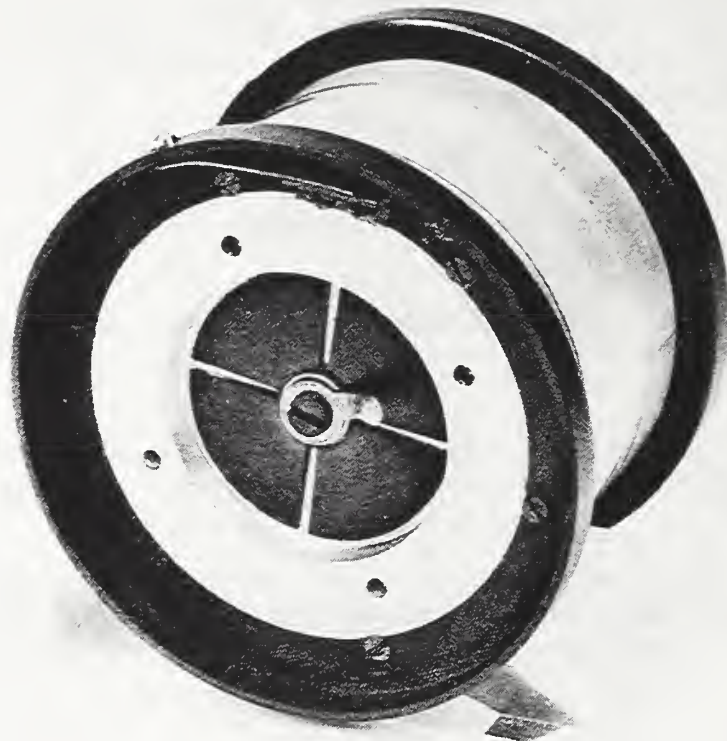

Quartz Oscillator, Marrison Type (c. 1929 to 1950) M373

HISTORICAL TEMPERATURE STANDARDS

The mercurial thermometer No. 4332 (M521) made by Tonnelot of Paris in 1884 was one of six assigned to the United States in 1889 as temperature standards for the range 0 to 100 °C, to accompany the Prototype Meters Nos. 21 and 27 and Prototype Kilograms Nos. 4 and 20. Baudin of Paris constructed the other three shown (M520a, 520b, 520c) between 1900 and 1907. All of these were made of lead-free hard glass, carefully annealed. They were exhaustively studied by C. E. Guillaume of BIPM, and certificates in the National Archives attest their errors of graduation, external and internal pressure coefficients, calibration corrections, and "super corrections" to the "mean verre dur" scale. The graduations are in 0.1 °C intervals, and could be read with a small telescope to 0.001 or 0.002 °C.

Sixteen of these thermometers served as national reference standards for three decades. Eventually they were intercompared with several thermometers of the platinum resistance type (M523). In 1927 the CIPM adopted an International Temperature Scale defined in terms of the standard form of resistance thermometer. This scale was modified in 1948, clarified in 1960, and replaced in 1968 by the present International Practical Temperature Scale (IPTS-68).

References

- Waidner, C. W. and Dickinson, H. C., On the Standard Scale of Temperature in the Interval 0 to 100 °C, Bull. Nat. Bur. Stand. 3, 663 (1907).
- Bussey, J., Liquid-in-glass thermometers, p. 228-255 in book, Temperature, Its Measurement and Control in Science and Industry, Reinhold Publ. Corp. (1941).
- CIPM, The International Practical Temperature Scale of 1968, Metrologia 5, 35 (1969).

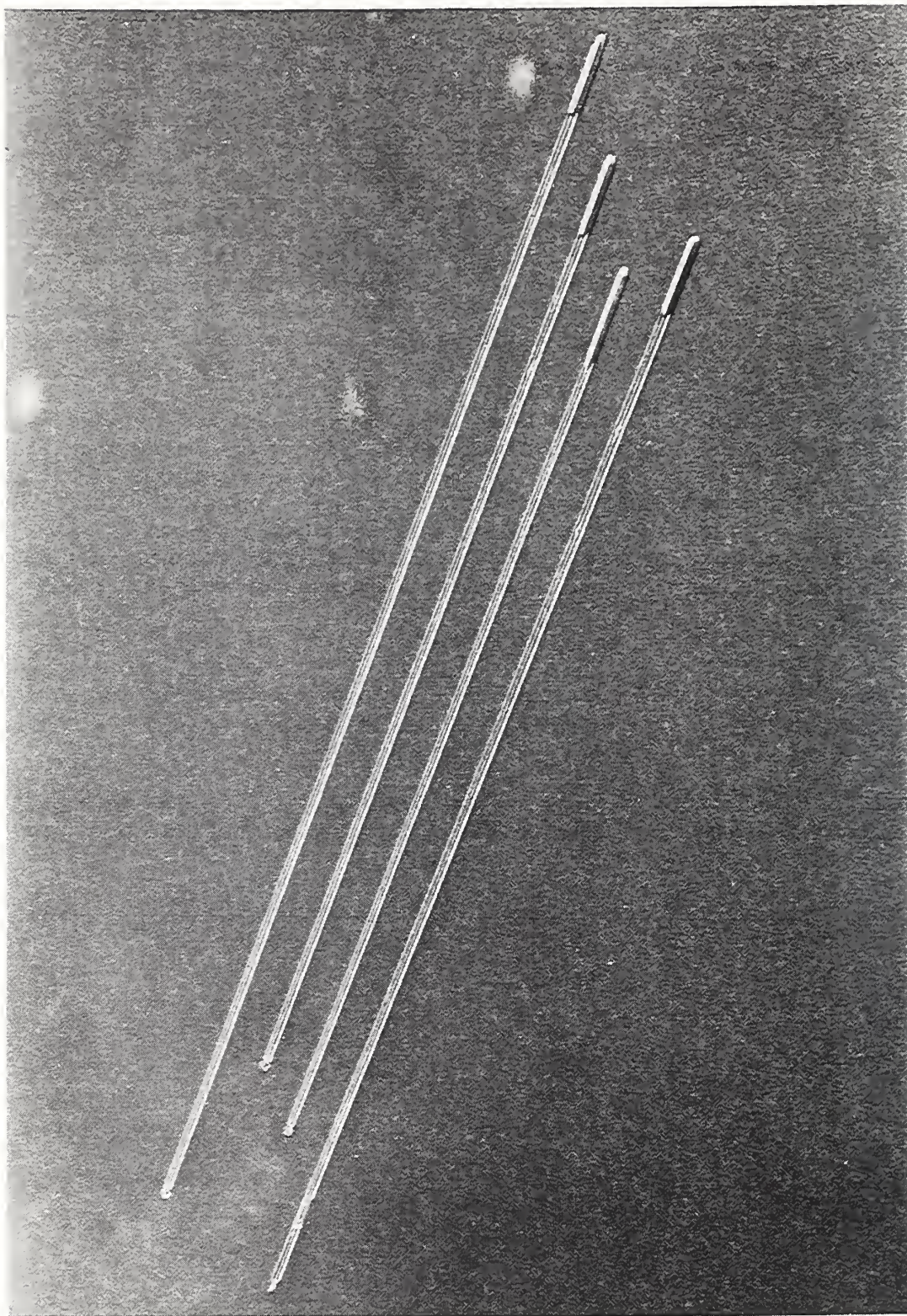

Mercurial Thermometers (1884 - 1907) M520A-B-C, M521

HISTORICAL STANDARDS OF LENGTH

EGYPTIAN ROYAL CUBIT

M444

Five thousand years ago, the Egyptians laid the foundation for all that is embraced by modern linear dimensional control. They produced the first master standard of linear measurement, the cubit, meaning "forearm." This standard was equivalent to the length of the forearm of the Pharaoh Amenhetep I (c. 1550 BC). It was about 52.5 cm (20.63 in) long, and was known as the Royal Cubit. As shown in this replica, the standard was subdivided by scribed lines which divided the cubit into two spans, six palms, and 24 digits (five finger breadths). The digits, in turn, were divided into halves, thirds, quarters and down to sixteen parts.

The Royal Cubit Master was made of black granite and placed in the custody of the royal architect. "Working" cubits made of wood were duplicated from the Royal Cubit and used by artisans in building the Great Pyramid, tombs and temple.

References

Berriman, A. E., *Historical Metrology*, Greenwood Press (1969).

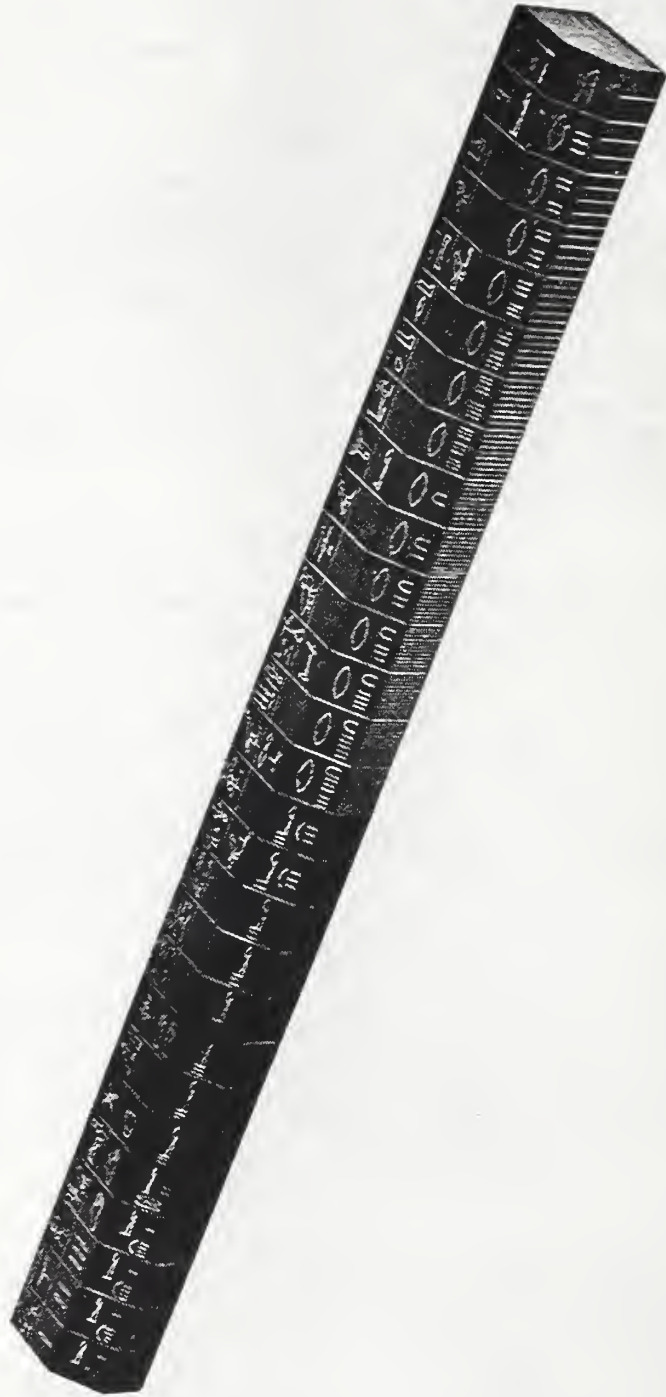

Egyptian Royal Cubit (Replica) (c. 1550 B.C.) M444

U.S. YARD STANDARDS

In this country at the time of the American Revolution, the British imperial yard was a commonly used standard, although there was no official prototype fixing its length. President Washington called attention to the need for "uniformity in weights and measures" in his first annual message to Congress in 1790, and John Quincy Adams submitted an elaborate report in 1821 which reviewed the standards in England and France.

References

Fischer, L. A., History of the Standard Weights and Measures of the United States, Nat. Bur. Stand. (U.S.), Misc. Publ. 64 (1905, 1925).

Judson, L. V., Weights and Measures Standards of the United States, Nat. Bur. Stand. (U.S.), Misc. Publ. 247 (Oct. 1963).

A graduated line-standard of length, commonly designated as an 82-inch bar, made by Troughton of London in 1813 and procured in 1814 for the United States by F. R. Hassler. The bar, 1/2 in by 2 1/2 in in cross section, is made of brass with an inlaid silver strip on which 1/10th-in graduations are engraved. The interval between the 27th and 63d in graduations was selected by the Treasury in 1832 to define the equivalence of the United States Standard Yard to the Imperial Standard Yard of 1760. The Troughton Scale retained its position as the primary reference yard standard of the United States until about 1857.

References

Fischer, L. A., History of the Standard Weights and Measures of the United States, Nat. Bur. Stand. (U.S.), Misc. Publ. 64 (1905, 1925).

Judson, L. V., Weights and Measures Standards of the United States, Nat. Bur. Stand. (U.S.), Misc. Publ. 247 (Oct. 1963).



Troughton Scale (1814) M316
Center view of scale showing the defined U.S. standard yard



Troughton Scale (1814) M316
Enlarged view of center of scale

A bronze line-standard of length, 1 in by 1 in in cross section, having an overall length of 38 in. Near each end of the bar is a cylindrical well with an inserted gold plug, the upper surface of the plug being 1/2 in below the top surface of the bar. The 1-yard defining lines are engraved on the gold plugs. This bar is of the same material and form as the Imperial Yard which was constructed as the British standard in 1855, to replace the one destroyed by a Parliament fire in 1834. It was presented to the United States by Great Britain in 1856. Being more convenient than the Troughton scale, this bronze bar was used as the standard yard of the United States from about 1857 to 1893. It was twice taken to England for recomparison with the Imperial Yard, once in 1876 and again in 1888.

References

- Fischer, L. A., History of the Standard Weights and Measures of the United States, Nat. Bur. Stand. (U.S.), Misc. Publ. 64 (1905, 1925).
- Judson, L. V., Weights and Measures Standards of the United States, Nat. Bur. Stand. (U.S.), Misc. Publ. 247 (Oct. 1963).



Bronze Yard No. 11 (1856) M317

An iron line-standard of length, similar in design and construction to Bronze Yard No. 11. It was presented to the United States by Great Britain in 1856 and was in use in the United States as a standard until 1893, although regarded as secondary in importance to Bronze Yard No. 11.

References

Fischer, L. A., History of the Standard Weights and Measures of the United States, Nat. Bur. Stand. (U.S.), Misc. Publ. 64 (1905, 1925).

Judson, L. V., Weights and Measures Standards of the United States, Nat. Bur. Stand. (U.S.), Misc. Publ. 247 (Oct. 1963).



Low Moor Iron Yard Bar No. 57 (1856) M318

METER BARS

"COMMITTEE METER"

1799

M314

An iron end-standard of length, 9 millimeters by 29 millimeters in cross section, designed to be one forty-millionth part of the length of the earth's meridian. It is one of a group of similar bars made by a Committee of the French Academy of Sciences that made the Meter of the Archives, whence its designation in the United States as the "Committee Meter." This particular bar was presented by Trallès, the Swiss member of the Committee, to his friend F. R. Hassler. Hassler, in turn, sold it to a member of the American Philosophical Society in Philadelphia, who deposited it with the Society. Later the bar was obtained from the Society by Hassler for the use of the U.S. Coast and Geodetic Survey, where it was used as the standard for scientific work in the United States from 1807 to 1893.

References

Judson, L. V., *Weights and Measures Standards of the United States*, Nat. Bur. Stand. (U.S.), Misc. Publ. 247 (Oct. 1963).

The Bureau of Standards: Its History, Activities and Organization, G. A. Weber, Johns Hopkins Press (1925).



"Committee Meter" (1799) M314

A platinum line-standard of length, 5 millimeters by 25 millimeters in cross section. The bar was procured from France by Albert Gallatin, Minister of the United States to France. It derived its designation from the name of the eminent French physicist who certified the length of its graduated interval. It appears that this bar has received essentially no use as a standard in the United States.

References

Fischer, L. A., History of the Standard Weights and Measures of the United States, Nat. Bur. Stand. (U.S.), Misc. Publ. 64 (1905, 1925).

Judson, L. V., Weights and Measures Standards of the United States, Nat. Bur. Stand. (U.S.), Misc. Publ. 247 (Oct. 1963).



Handwritten text, likely an inscription, appearing in a cursive script. The text is mostly illegible due to fading and the angle of the scan.



Arago Platinum Meter (1821) M315
Center view shows inscription

HISTORICAL STANDARDS OF LUMINOUS INTENSITY

STANDARD CANDLES 1889 M269

The London Metropolis Gas Act of 1860 specified two sperm candles of six to the pound, each burning 120 ± 6 grains an hour, for use in flame photometry. This specification was confirmed by the Gas Referees in 1889, but was changed to the Harcourt lamp in 1898.

FLAME STANDARD, CARCEL 1906 M270

Lamps of this type, designed by B. G. Carcel in 1800 to burn colza (rapeseed) oil, were used as prototype standards of luminous intensity at the Laboratoire Central d'Electricité in Paris in 1906. A clockwork pump supplied oil to the wick. Earlier comparisons with Violle's proposed standard (based on the luminous intensity of 1 square centimeter of a platinum surface at its melting point) led to assigning a value of "9.6 bougies décimales" to such a lamp when burning at the rate of 42 grams per hour. The "bougie décimale" had been defined as 1/20 of a "Violle" and had about the same value as the British Parliamentary "candle."

FLAME STANDARD, HEFNER-ALTENECK 1893 M271

The legal standard of candle-power adopted in 1893 by the Physikalisch-Technische Reichsanstalt of Germany is the lamp devised in 1884 by F. von Hefner-Alteneck. A thin German-silver tube exactly 25 mm high, 8 mm internal diameter, and 0.15 mm thick holds a wick of untwisted cotton; the fuel is amyl acetate. The candle-power of the reddish flame depends appreciably on its height, and somewhat on humidity and barometric pressure. In 1909 and again in 1921, its value was agreed to be exactly nine-tenths of the international candle.

References

- Stine, W. M., Photometrical Measurements (Macmillan, N.Y., 1900).
- Palaz, A. (transl. G. W. and M. R. Patterson), A Treatise on Industrial Photometry (Van Nostrand, N.Y., 1894).
- Walsh, J. W. T., Photometry (Constable, London, 1926, 1965).
- Rosa, E. B. and Crittenden, E. C., Flame Standards in Photometry, Bull. Nat. Bur. Stand. 10, 557 (1914); Sci. Paper 222.

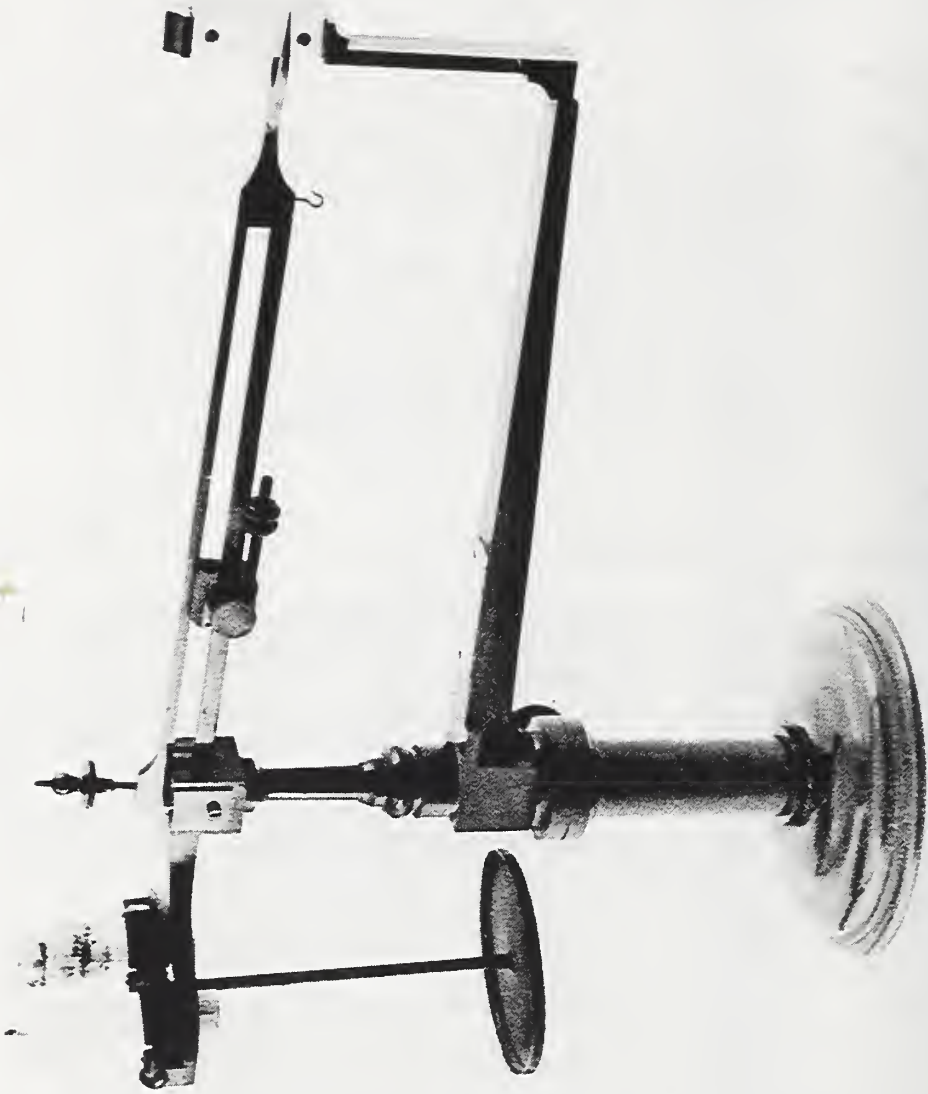

Standard Candles (1889) M269



Flame Standard, Carcel (1906) M270

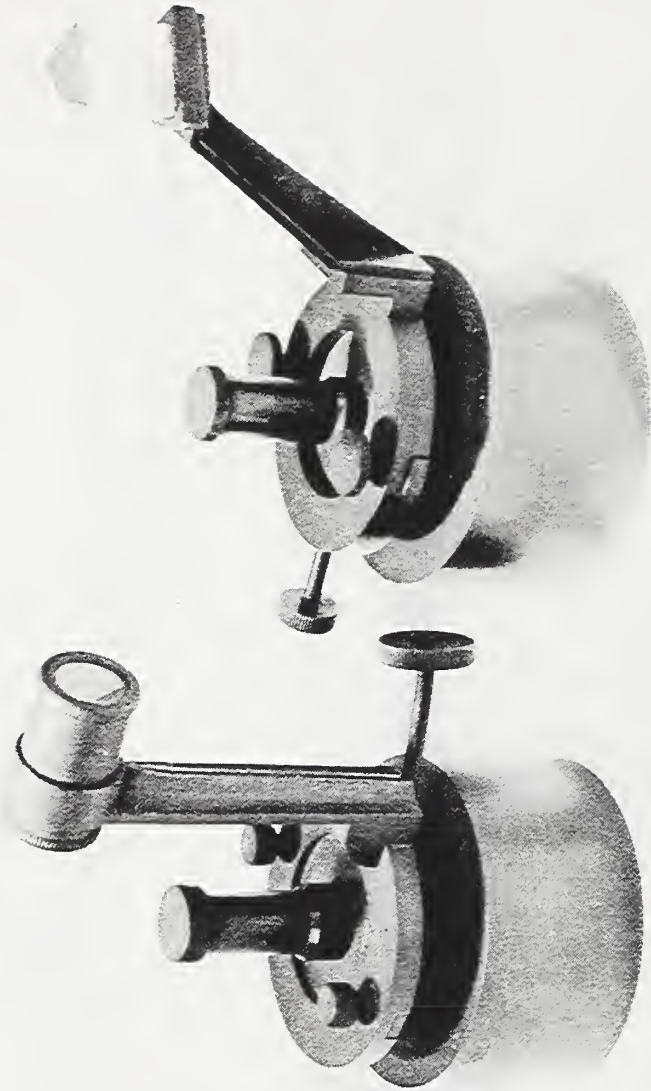

Flame Standard, Hefner-Alteneck (1893) M271

AREA 4
Gravitation 

The factor G in the Newtonian formula $F = G \times Mm/d^2$ is the universal constant of gravitation which enters into the calculations of geologists, astronomers, and planetologists. It was measured in 1798 in a classic experiment by Henry Cavendish, and again by Carl Braun in 1897, using a torsion pendulum apparatus. The experiment was repeated at NBS by Paul Heyl in 1930 and by Heyl and Chrzanowski in 1942, in an effort to improve the then accepted value.

The mockup displayed here shows the 1942 arrangement. Small platinum balls of 87-grams mass were hung from either end of a 20-cm aluminum tube, which was suspended symmetrically by a 0.025 mm filament of annealed tungsten one meter long, forming a torsion pendulum. Cylindrical steel masses weighing about 66 kilograms were mounted symmetrically on a ring rotatable in azimuth so that they could be positioned either "near" to or "far" from the small masses. In the evacuated housing the swing of the pendulum, initially about 4 degrees, could be sustained for nearly 20 hours. With the "near" configuration the average period was 2200 seconds; with the "far" configuration 2920 seconds. These data, together with precise measurements of the spatial geometry, permitted computation of G as $6.673 \pm 0.003 \times 10^{-11} \text{ m}^3 \cdot \text{s}^{-2} \cdot \text{kg}^{-1}$. (The four glass balls (M12) in the case to the left were used in the 1930 experiment.)

In 1974 the value recommended by the International Council of Scientific Unions is 6.6720×10^{-11} , to an uncertainty within 41 parts per million. Of the five major G projects currently going on around the world, two are at NBS, and use improved torsion pendulums. Deslattes, Luther, and Towler at NBS Gaithersburg are working with apparatus devised by Jesse Beams of the University of Virginia. Koldewyn and Faller at Boulder (University of Colorado) are comparing pendulum periods subject to the gravitational pull of the Rocky Mountains, both with and without the effect of nearby large masses of bronze.

References

- Heyl, P. R., A redetermination of the constant of gravitation, Nat. Bur. Stand. (U.S.), J. Res. 5, 1243 (1930).
- Heyl, P. R. and Chrzanowski, P., A new determination of the constant of gravitation, Nat. Bur. Stand. (U.S.), J. Res. 29, 1 (1942).
- Specifications of the Physical World, Dimensions/NBS 58, 3 (Jan. 1974).
- How Big is G , Dimensions/NBS 58, 176 (Aug. 1974).

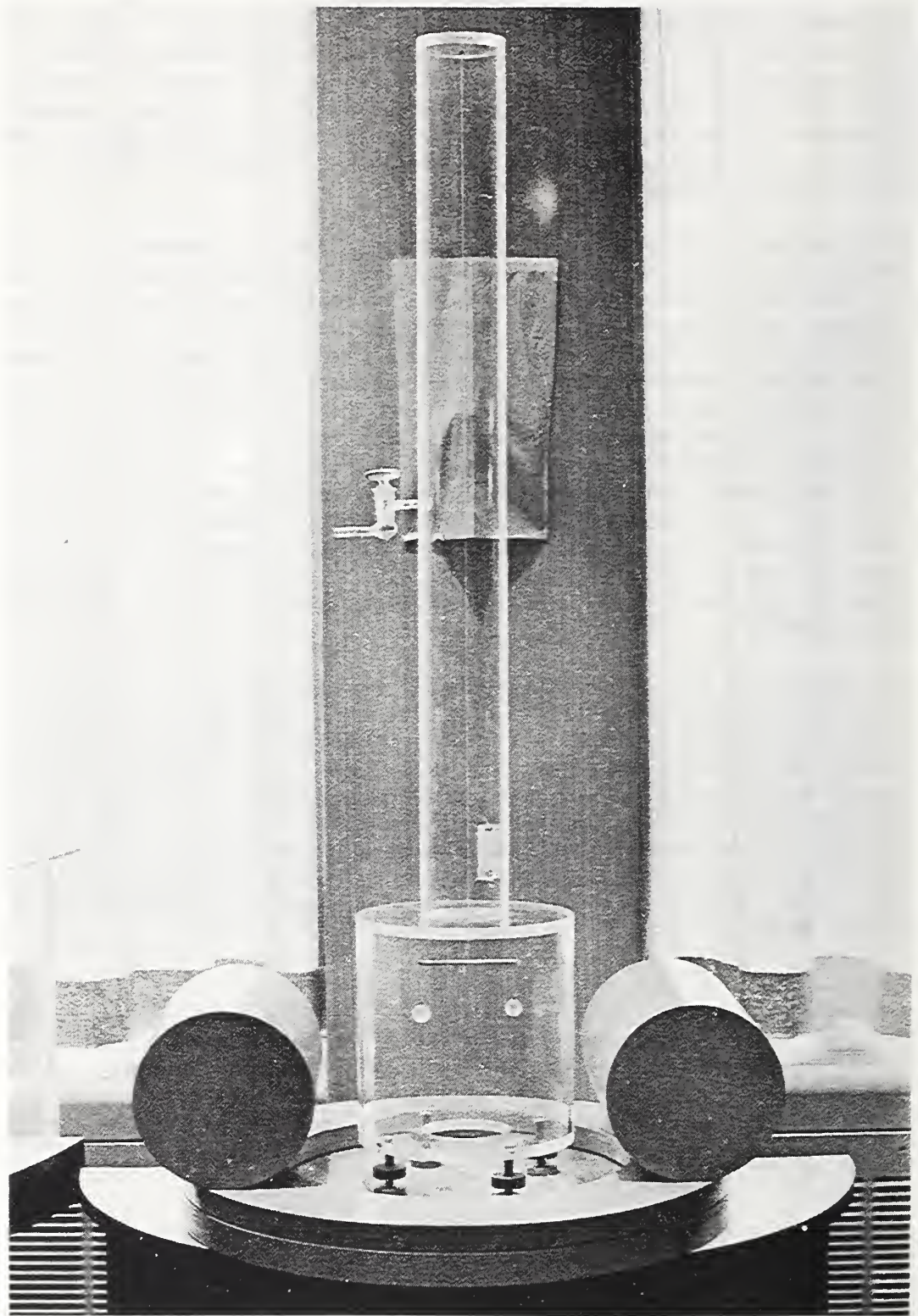

Gravitation Apparatus (Mockup) (1942) M561

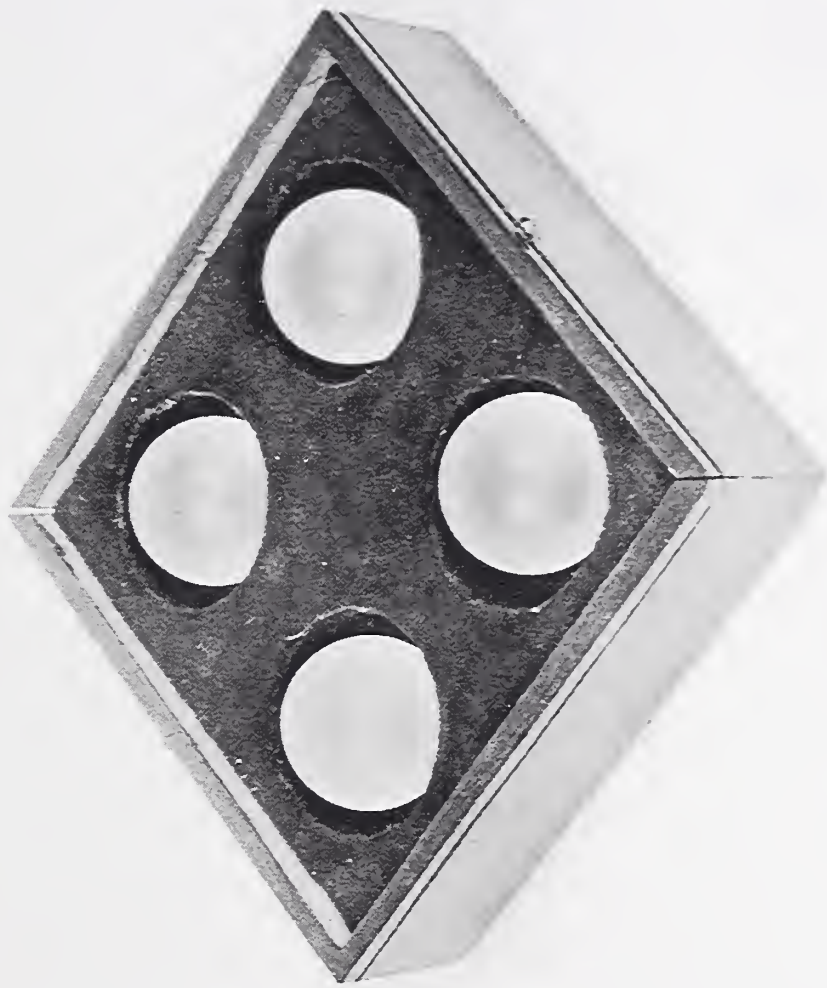

Glass Balls (1930) M12
Used by P.R. Heyl of NBS in 1930 to determine
the universal constant of gravitation.

AREA 5 - FLAT CASE

Radioactivity & X-Rays



Sir William Ramsay of London had just been awarded a Nobel prize for the identification of the rare atmospheric gases--argon, helium, neon, krypton, and xenon. He sent samples to NBS, which was planning a novel exhibit in the Palace of Electricity at the Louisiana Purchase Exposition in St. Louis. Electric discharge tubes containing gas at low pressure (Plücker tubes) had been used by P. G. Nutting for the study of gaseous spectra. His design with 2 cm plate electrodes, which provided a much steadier and brighter light, was used in these signs blown by E. O. Sperling.

About 1930, the neon tube was commercialized and a whole new industry was thus founded.

References

Travers, M. W., The Discovery of the Rare Gases (Edward Arnold & Co., London, 1928).

Cochrane, R. C., Measures for Progress, Nat. Bur. Stand. (U.S.), Misc. Publ. 275, 83 (1966).

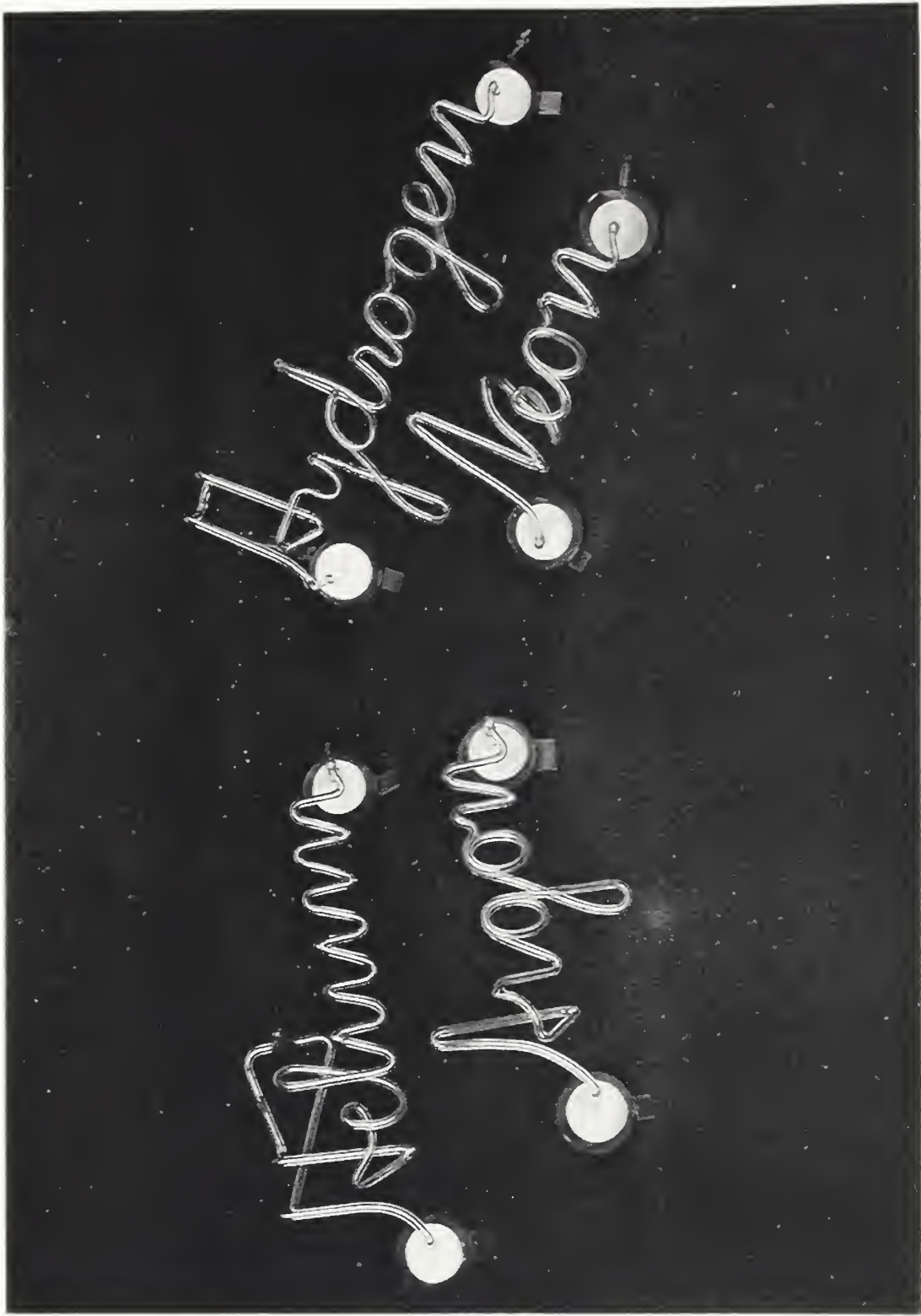

Luminous Script Signs (1904) M272

This lead-lined ionization chamber, for measuring x-radiation in roentgens, was designed by L. S. Taylor to provide a small light-weight secondary standard which could be used for international intercomparisons of x-ray standards. The NBS primary standard at that time had a parallel-plate system and grounded lead shielding box which was large, and consequently heavy and cumbersome. This new free-air chamber design retained the parallel-collection high-voltage plate system but introduced the use of guard wires connected to a potential divider. These provided a uniform gradient in the electric field from the collector-guard plates to the high voltage plate, as a result of which the length of the guard plates and the size of the shielding box could be reduced. The eight vertical guard wires are about 12-mm apart except in the middle where they are 18-mm apart to provide clearance for the x-ray beam. The chamber was mounted on a swivel base and track to permit alinement with the x-ray beam. The beam diameter in the chamber is defined by an 8-mm-diameter lead diaphragm which is mounted in the lead-lined brass tube. The brass tube was fitted with a solenoid-operated lead shutter to fix the x-ray exposure interval.

Such a guarded-field ionization chamber was used in 1931 for the first direct intercomparison of free-air primary standards of the United States, England, and Germany. The comparisons showed the agreement between the standards of the three nations to be within 0.5 percent. Similar chamber designs are still in use.

References

- Taylor, L. S. and Singer, G., An improved form of standard ionization chamber, Nat. Bur. Stand. (U.S.), J. Res. 5, 507 (1930).
- Taylor, L. S., International comparison of x-ray standards, Nat. Bur. Stand. (U.S.), J. Res. 8, 9 (1932).

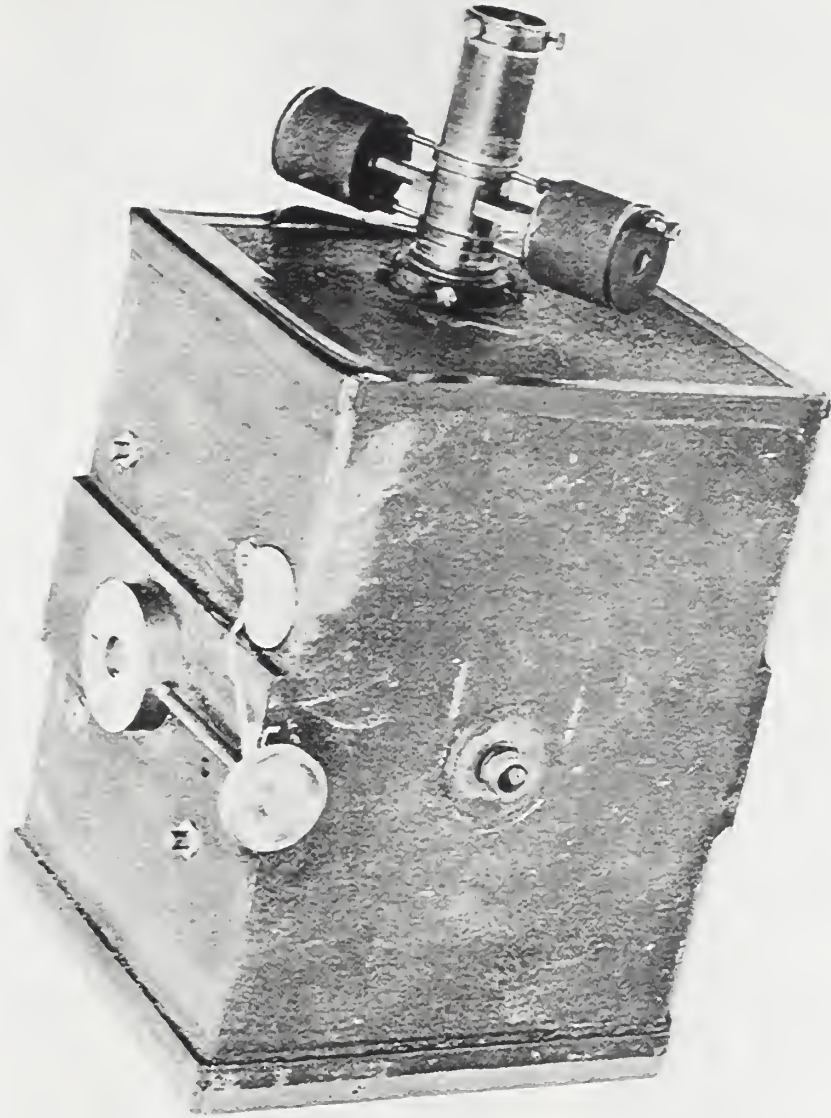

Ionization Chamber, Guarded Field (1928) M337

AREA 6 - FLAT CASE

Radiation, Mechanics, Magnetics





This pillbox design of 4π proportional flow counter was designed and tested by H. H. Seliger and L. M. Cavallo, following a suggestion from C. J. Borkowski of Oak Ridge National Laboratory. It consists of two 2π counters mounted face to face, and separated by a thin stainless steel diaphragm with peripheral holes for the passage of the counter gas (methane). The tubes in the upper half are inlets for the gas, which is withdrawn from the bottom.

The pillbox counter made possible the high-efficiency counting of beta particles from radioactive materials with activities as low as 10 nuclear transitions per second. It was rugged, easily decontaminated, and proved to be stable over long periods of time. It has been used for calibrating sources of ^{14}C , ^{22}Na , ^{24}Na , ^{35}S , ^{60}Co , $^{90}\text{Sr}+^{90}\text{Y}$, and ^{198}Au . A thin deposit of source material was mounted on a Formvar-polystyrene film cemented over a 2-cm hole in the central diaphragm. Operation was in the region of limited proportionality where the gas gain and the electronic gain are about 10^4 and 5×10^3 , respectively.

After some years of use, the pillbox design was superseded by a cylindrical and then by a spherical form of 4π proportional flow counter.

References

Seliger, H. H. and Cavallo, L. M., Absolute standardization of radioisotopes by 4π counting, Nat. Bur. Stand. (U.S.), J. Res. 47, 41 (July 1951).



Radioactivity Counter (1951) M340

From 1908 to 1940, W. W. Coblentz studied the instruments and methods of radiometry, devising various forms of thermopiles and applying them to the measurement of total radiation from the stars, the planets, and various materials. The 10-junction linear thermopile displayed is his #133, constructed in 1923. It is made of 0.08 mm bismuth wire and 0.031 mm tin foil. The target has a continuous surface and a definite area of 10 mm^2 which permits calibration for measurements in absolute units. Its front is coated with lampblack, better to absorb the external radiation; the rear is bright, better to reflect radiation from within the enclosure. To facilitate the joining of these fine wires, Coblentz in 1913 introduced the idea of welding them close together on tiny rectangles of tin rather than directly to each other.

For measuring stellar radiation received through a telescope, increased sensitivity and freedom from convection currents were obtained by enclosing the radiometric element in a strong glass case evacuated to about 0.1 mm mercury. Its lead wires were sealed into the tubular extension, as were platinum electrodes, to be used with an induction coil to test the evacuation. When measurements were to be made at remote observatories, a quartz tube filled with chips of metallic calcium was sealed to the bent neck, and residual gases were removed by heating the tube to redness.

A balanced thermocouple design (viewed from the bright rear) is numbered 244 and dated June 14, 1932. Exposed to solar radiation, its overheating was prevented by a water cell of fused quartz 1 cm thick. To measure the ultraviolet intensity, first one and then the other of the two 4 mm thermocouple discs was covered by a quartz window, while the opposite disc was covered by one or two barium-flint glass filters.

Between 1912 and 1940 Coblentz personally made 264 thermocouples and thermopiles. Some of these were sold to laboratories throughout the United States and Europe.

References

- Coblentz, W. W., Instruments and Methods Used in Radiometry-II, Bull. Nat. Bur. Stand. 9, 7 (1913).
- Coblentz, W. W., A Comparison of Stellar Radiometers and Radiometric Measurements on 110 Stars, Bull. Nat. Bur. Stand. 11, 613 (1915).
- Coblentz, W. W. and Stair, R., Measurement of extreme ultraviolet solar radiation using a filter method, Nat. Bur. Stand. (U.S.), J. Res. 6, 951 (1931).

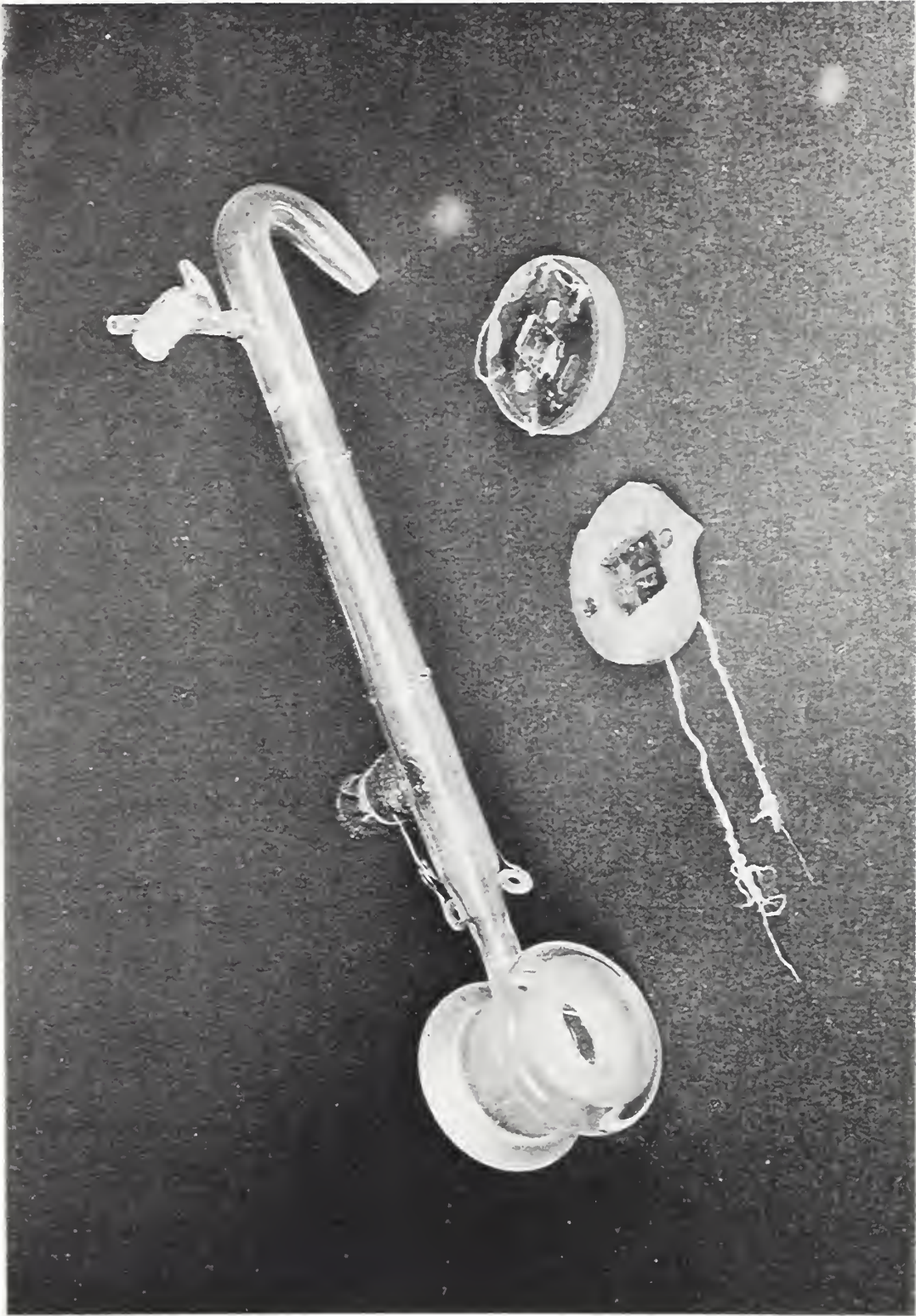

Thermopiles (1923) M202

Because of the sensitivity, the small size, and the light weight of this optical extensometer system designed by L. B. Tuckerman, it is well adapted to measuring deformations on short gage lengths, even on materials such as celluloid sheet or aluminum wire. The gage body on display carries a knife edge at the upper end and would be held to the specimen by a light spring. At the lower end is a Martens lozenge of stellite about $3/4$ in long, carefully machined and polished to a square section 0.2 in on a diagonal. One longitudinal edge of the lozenge bears against the gage body, while the diametrically opposite edge bears against the specimen.

An essential element in the optical system is a Tuckerman auto-collimator (not on display) which originates a collimated light beam. Inside the gage body is fixed a roof prism which doubly reflects the beam and projects it through a 45° prism onto a polished side of the lozenge and back into the collimator eyepiece. As the strained specimen extends or contracts, the lozenge tilts about its contact with the gage body, and the reflected beam strikes a reticule with a scale graduated to read strain directly in inches per inch on a 2-in gage length. Adjustment of the roof prism position is made by the knurled knob on the gage body.

With this system, strain can be measured with sensitivity of one millionth of an inch per inch, and within an accuracy of about 3 millionths. Collimator and body are available commercially. The instrument is still used for precise measurement of Young's modulus and Poisson's ratio, and as a reliable standard for evaluating the more convenient bonded-wire strain gages which provide electrical readout.

References

Tuckerman, L. B., U.S. Pat. 1,736,682.

Tuckerman, L. B., Optical strain gages and extensometers, Proc. Amer. Soc. Testing Mat. 23, 602 (1923).

Wilson, B. L., Characteristics of the Tuckerman strain gage, Proc. Amer. Soc. Testing Mat. 44, 1017 (1944).

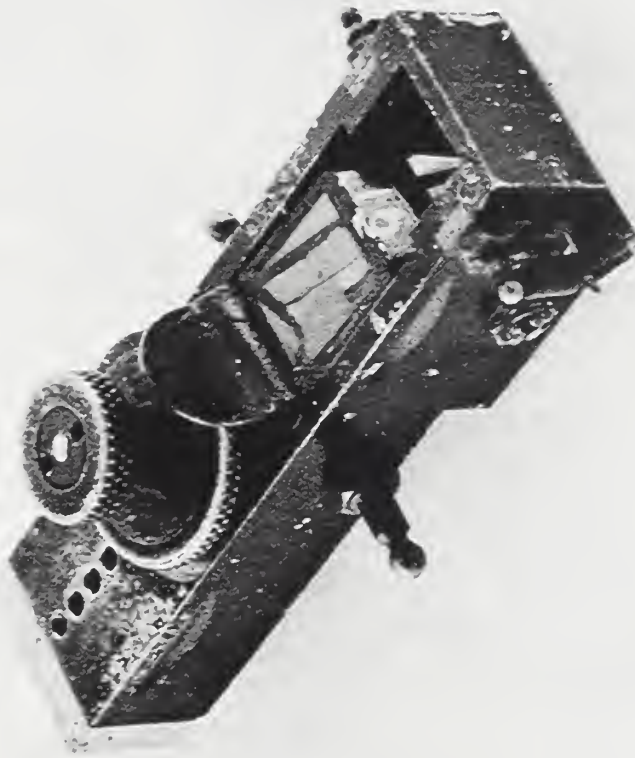

Strain Gage, Tuckerman (1923) M34

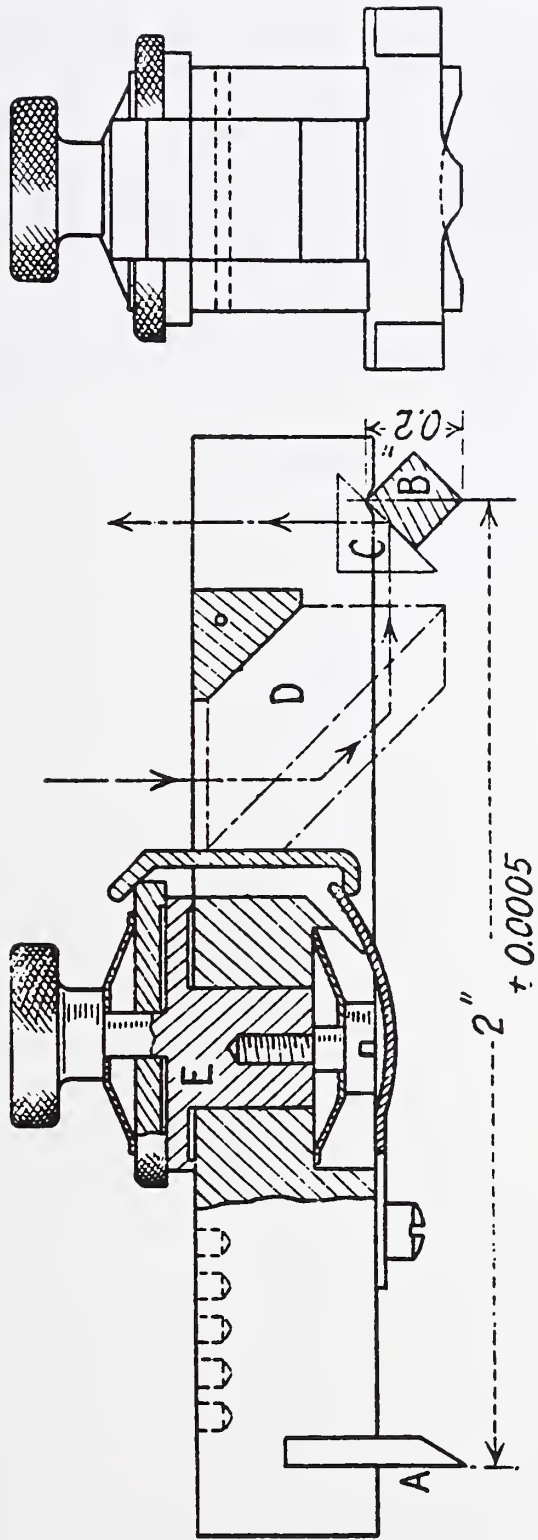

Diagram of Tuckerman Strain Gage (1923) M34



This hand-held device for measuring the elongation of a 10-in gage length in large structural members such as bridge trusses was designed for use under adverse conditions in the field. Its conical gage points, which fit into pairs of small drilled holes, remain perpendicular to the surface of the structure, an advantage not afforded by earlier strain gages. The gage points are carried by a pair of Invar channels coupled by flexure plates which permit small parallel displacements. Their relative motion is measured by a ten-thousandth inch dial indicator.

The design has been made commercially, and is still commonly used when structural strains must be measured at intervals over long periods of time.

References

Whittemore, H. L., The Whittemore strain gage, Instruments I, 299 (1928).



Strain Gage, Whittemore (1926) N36

This device was developed by Abner Brenner for making rapid non-destructive measurements of electroplated nickel coatings on nonmagnetic base metals. It measures the force (about 10^{-2} newton) required to detach one pole of a small permanent magnet from the nickel surface. That force was found to be proportional to the thickness of the coating, to within about 10 percent, for a range of 0.0001 to 0.0025 in (0.0025 to 0.063 mm). The magnet hangs vertically from a horizontal torque arm. A specimen to be tested is placed on the stand, and the platform lowered until the magnet just touches it. Rotation of the arm carrying the outer end of the spiral spring provides a force opposing the magnetic attraction. The bent lever under the torque arm provides for sensitive detachment when the forces balance.

Calibration is accomplished by noting the detachment force required for coatings of known thickness. Although different conditions of electrodeposition were found to affect this force, consistent results were obtained by annealing to 400 °C. The instrument has been used for measuring thicknesses from 0.0001 to 0.080 in (0.0025 to 2 mm) of nickel coatings on steel, and nonmagnetic coatings on steel. It has been produced as a commercial tester for many years.

References

Brenner, A., Magnetic method for measuring the thickness of nonmagnetic coatings on iron and steel, Nat. Bur. Stand. (U.S.), J. Res. 20, 357, RP1081 (1938).

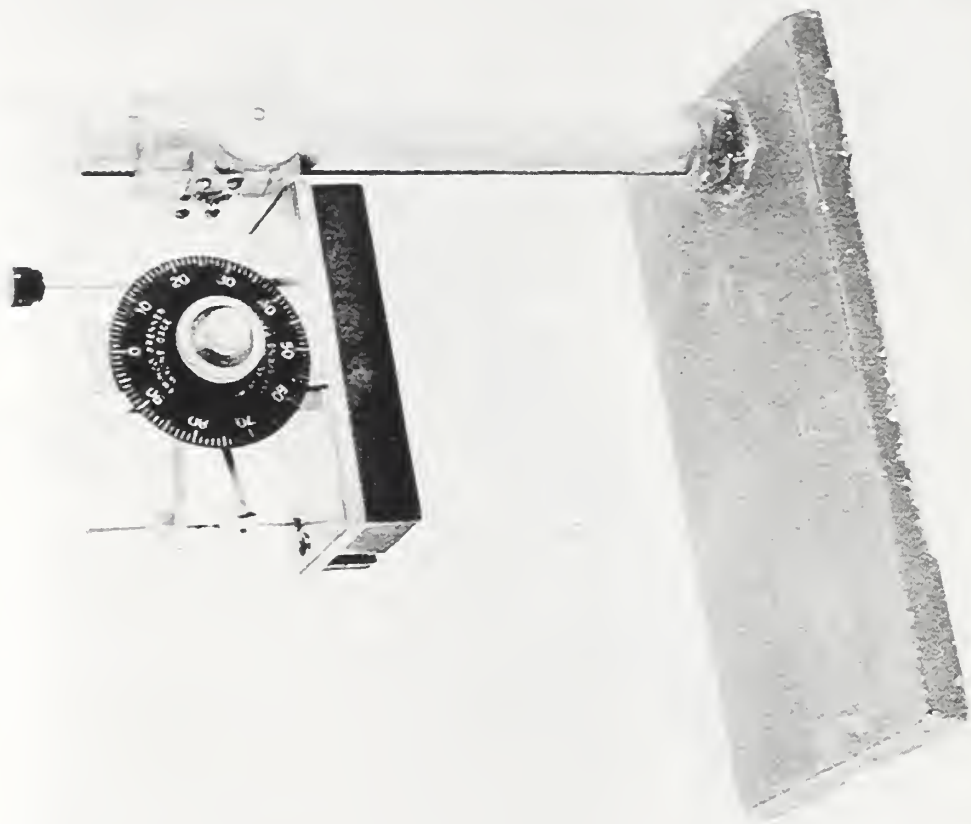

Magnetogage (1937) N415

This instrument for determining the normal magnetic induction curve and the hysteresis loop for a straight round specimen was designed by C. W. Burrows of NBS, utilizing the idea of a distributed and adjustable magnetomotive force. Its magnetic circuit consists of two approximately identical bars 250 mm long, their ends being clamped by brass screws in two connecting yokes of high permeability. Yoke ends are hemispherical to minimize flux leakage into air. The main magnetizing solenoids consist of 10 layers of No. 18 copper wire wound with 7.958 turns per centimeter, to make $H = 10 I$. They extend over the entire length of the two bars between the yokes. A compensating coil with four windings in series is added at the four ends.

The main test coil is wound closely over the middle quarter of the bar chosen as test specimen. On each side of this, midway between it and the yokes, are wound the two halves of a second search coil. A third coil, similar to the first, is wound over the auxiliary bar.

This permeameter was accepted by ASTM for use with magnetizing forces up to 300 oersteds. It was used to measure the properties of standard bars for calibrating other instruments. However, the adjustment procedure is tedious, and the device gives dependable results only when the specimens are known to be magnetically uniform.

References

- Burrows, C. W., The Determination of the Magnetic Induction in Straight Bars, Bull. Nat. Bur. Stand. 6, 31 (1909).
- Harris, F. K., Electrical Measurements, p. 372 (John Wiley & Sons, N.Y., 1952).

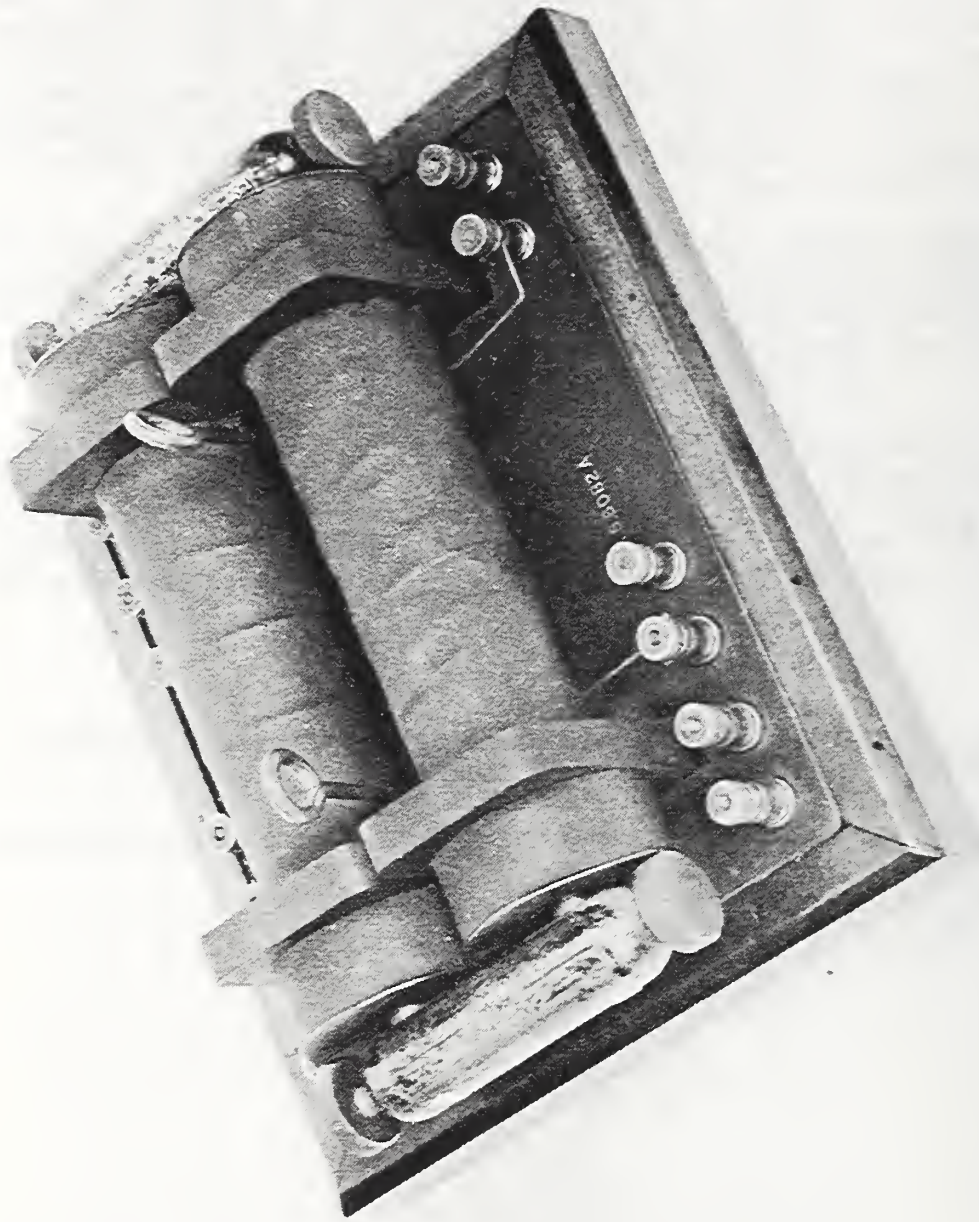

Permeameter (1909) M182

This is the first laboratory model of the variable-torque clutch (or brake) invented by Jacob Rabinow of NBS. The shaft at the bottom carries a shallow chamber 6 mm thick and 120 mm in diameter, made of nickel steel. The shaft at the top carries at its lower end a nickel steel disc 3 mm thick and 90 mm in diameter, which turns freely inside the shallow chamber.

A toroidal electromagnet just inside the chamber circumference is wired to slip-rings mounted atop the chamber.

The chamber is completely filled with a mixture of 8 μ m soft-iron dust particles and light lubricating oil. This offers negligible resistance to relative rotation of disc and chamber. However, as current is supplied to the electromagnet, magnetic flux is set up between the disc and the chamber by way of the particles. As the flux is increased, increasing torque can be transmitted from one shaft to the other.

Because of the simple design, precise torque control, smooth operation, and long life, similar devices have found wide application, ranging from automobile clutches to pilotless aircraft. More than 300 patents now cite the original NBS patent.

References

Rabinow, J., Magnetic fluid torque and force transmitting device, U.S. Patent 2,575,360.

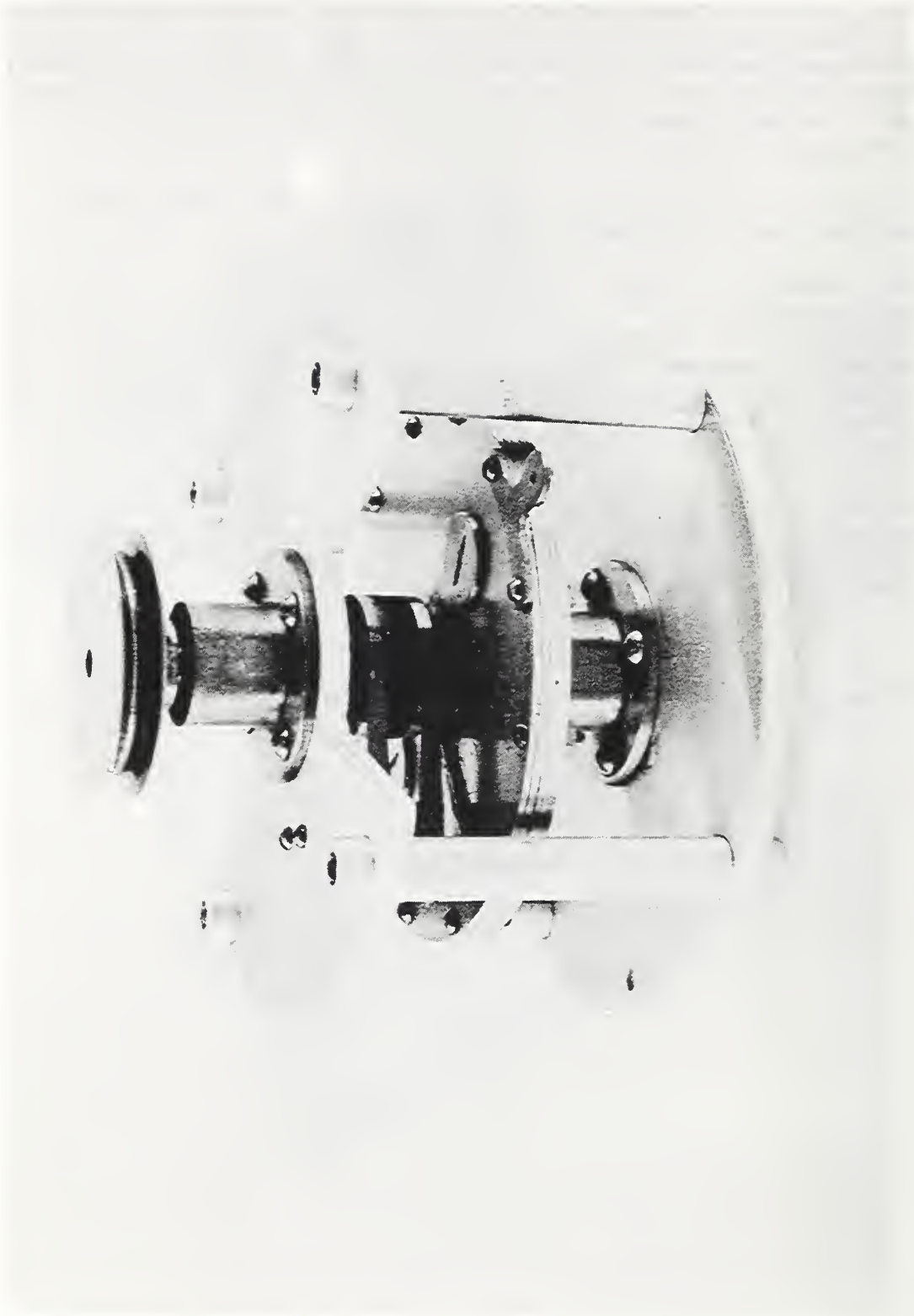

Magnetic Particle Clutch (1947) M2

Stainless (austenitic) steels are extensively used for their resistance to corrosion. In them, the iron exists originally in the nonmagnetic gamma phase. The iron may revert to the paramagnetic form, which is less corrosion resistant in fabrication processes such as welding, or in severe service conditions. Thus magnetic permeability measurements provide a convenient index of corrosion resistance.

This portable device was developed by R. L. Sanford of NBS at the suggestion of P. E. McKinney of the Bethlehem Steel Co. Set on the surface of a structure, it is used to measure the force required to pull one end of a permanent bar magnet away from the surface. A graduated dial indicates the angle through which one end of the helical spring must be turned to accomplish this. The relation between dial readings and magnetic permeability is approximately linear from 1.0 to 2.5.

References

Sanford, R. L., A magnetic balance for the inspection of austenitic steel, Nat. Bur. Stand. (U.S.), J. Res. 10, 321, RP532 (1933).

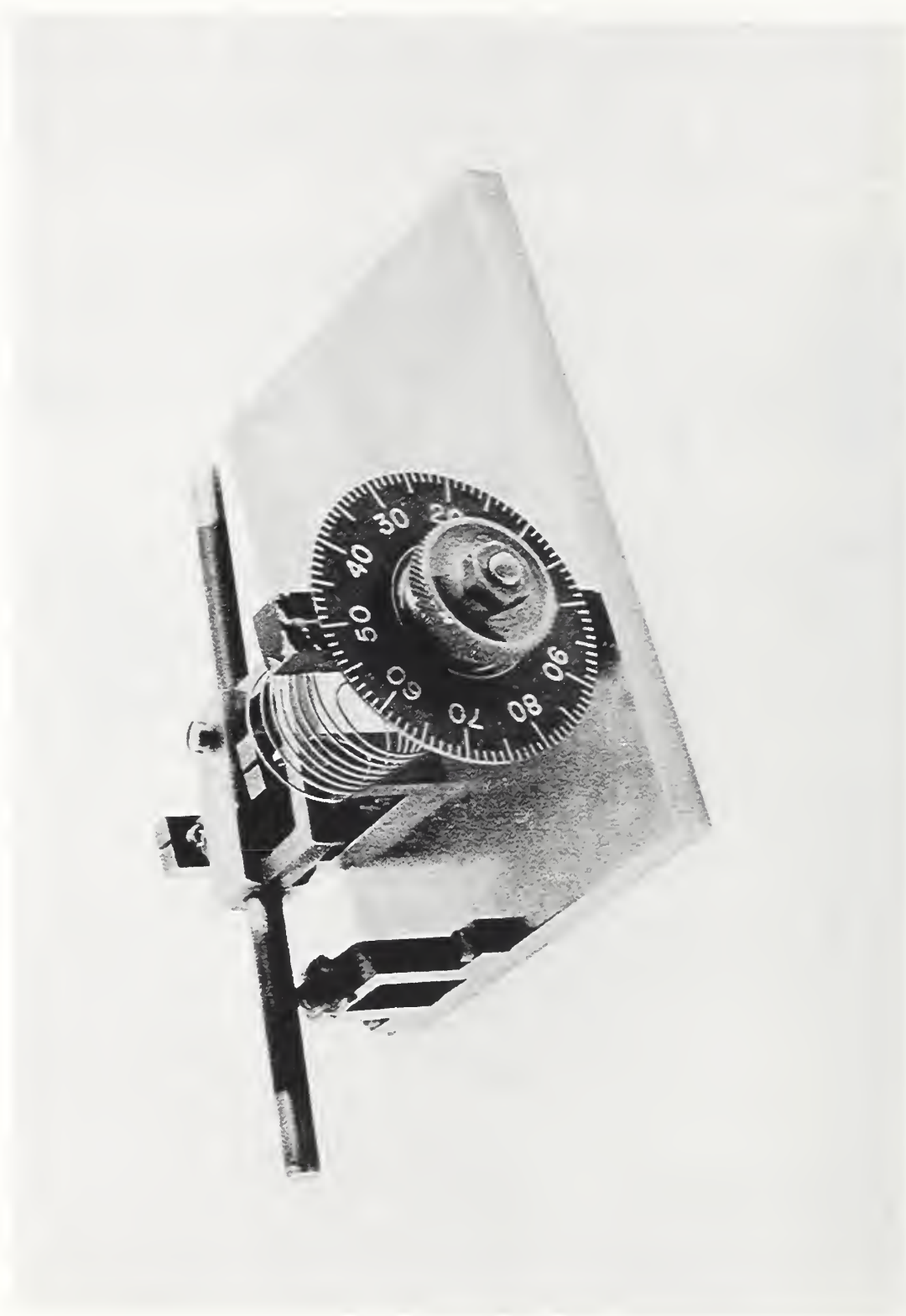

Magnetic Balance (1932) M19

AREA 7 - FLAT CASE - **Radio** 

Early radiosondes used a hair hygrometer for measuring humidity in the upper atmosphere, but the material was too slow to respond to changes with rapid ascent, and would not function at all above about 8000 metres altitude. F. W. Dunmore's work at NBS was aimed at developing a sensing device which would use electrical resistance. His humidity-sensing resistor consists of a short aluminum tube with 0.01-in wall, coated with polystyrene resin and wound with 20 turns of a pair of bare palladium wires. A thin film of partially hydrolyzed polyvinyl acetate and lithium chloride salt absorbs moisture from the air and provides a variable resistance between the wires.

For radiosondes, a three-element unit having 1-, 2- and 3-percent lithium chloride solution was used. With five elements, the range from 10 to 95 percent relative humidity can be covered. Stability has been shown to be within ± 3 percent over a period of several months, with a temperature range from $+30$ °C to -40 °C.

References

Dunmore, F. W., An electric hygrometer and its application to radio meteorography, Nat. Bur. Stand. (U.S.), J. Res. 23, 701 (Dec. 1939).

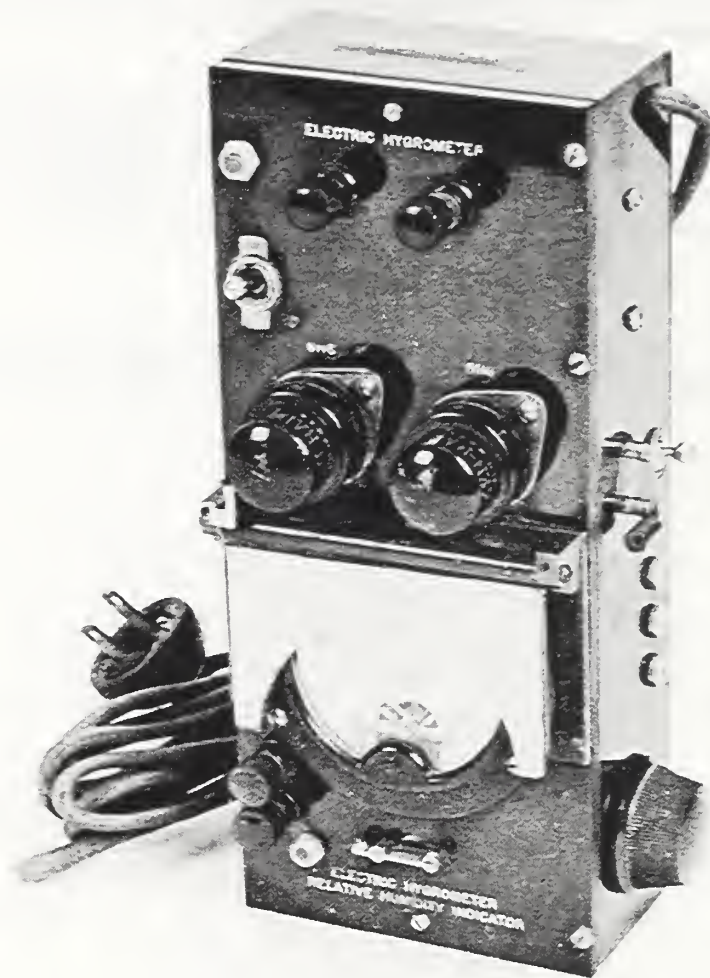

Electric Hygrometer (1938) M33

Practical systems for the study of upper-air phenomena by small radio-equipped sounding balloons were first examined at NBS for the Weather Bureau. A design using the Olland principle and a 5-meter transmitter was proposed in 1935 and later improved by using a light-weight constant-speed dc motor to drive a rotating contact. In each revolution contact was made successively with three double-pronged arms whose angular positions were altered proportionally to temperature, humidity, and pressure by appropriate sensing elements. M167 is an experimental model of such a radio meteorograph recovered after flight.

Beginning in 1936, another design was developed for the Navy Department. This used an ultrahigh transmission frequency (65 MHz, later 403 MHz) and a voltage-controlled negative transductance circuit in which the modulation frequency (20 to 200 Hz) was inversely proportional to the grid-circuit resistance. A barometric diaphragm capsule responding to pressure at ascension rates of 200 to 300 meters per minute drove a contactor across a switching element consisting of 80 metallic strips separated by insulating strips. A reference resistor, switched in at every fifth contact, served as an index mark on this pressure scale. Resistance changes corresponding to temperature were provided by a capillary electrolytic thermometer, while humidity was measured by changes in resistance of a film of lithium chloride (M33).

M163 is an early production model made by Julien P. Friez and Sons about 1937. M164 is an improved type with pulsed carrier at 403 MHz, in use from 1942 to 1962. M165 is a transistorized version using the 403 MHz carrier, used from 1959 on.

In 1975 radiosondes are sent up twice a day from 96 stations of the National Weather Service. In addition to the 403 MHz design, newer types include hypsometers and automatic wind-direction sensing at 1680 MHz.

References

- Curtiss, L. F. and Astin, A. V., *J. Aeron. Sci.* 3, 35 (1935).
- Diamond, H., Hinman, W. S., and Dunmore, F. W., A method for the investigation of upper-air phenomena and its application to radio meteorography, *Nat. Bur. Stand. (U.S.), J. Res.* 20, 369 (Mar. 1938).
- Curtiss, L. F., Astin, A. V., Stockman, L. L., and Brown, B. W., An improved radio meteorograph on the Olland principle, *Nat. Bur. Stand. (U.S.), J. Res.* 22, 97 (Jan. 1939).
- Diamond, H., Hinman, W. S., Dunmore, F. W., and Lapham, E. G., An improved radiosonde and its performance, *Nat. Bur. Stand. (U.S.), J. Res.* 25, 327 (Sept. 1940).



Radiosondes (1935)

- Olland type M167 (top left); Early type M163 (top right); Pulsed type M164 (bottom left); Transistor type M165 (bottom right)

In the early years of radio broadcasting, radio receivers were powered exclusively by batteries. P. D. Lowell and F. W. Dunmore demonstrated at NBS that the inconvenience of batteries could be avoided by using household 110-volt alternating current (ac) instead. Their several circuit modifications of a typical battery receiver (U.S. Pat. 1,455,141) permitted the use of ac house current with small sacrifice in quality of performance. The national transition to ac powered receivers required other inventions and several additional years of development in the radio art, but the example of the Lowell-Dunmore receiver accelerated the transition. Their receiver used three stages of vacuum-tube radio-frequency amplification, a crystal detector, two audiofrequency stages, and a telephone-receiver loudspeaker.

The instrument on display was built in 1923 by the Radio Instrument Co.

References

Lowell, P. D., An electron tube amplifier using 60-cycle alternating current to supply power for the filaments and plates, Nat. Bur. Stand. (U.S.), Sci. Papers 18, 345, RP450 (1922-23).

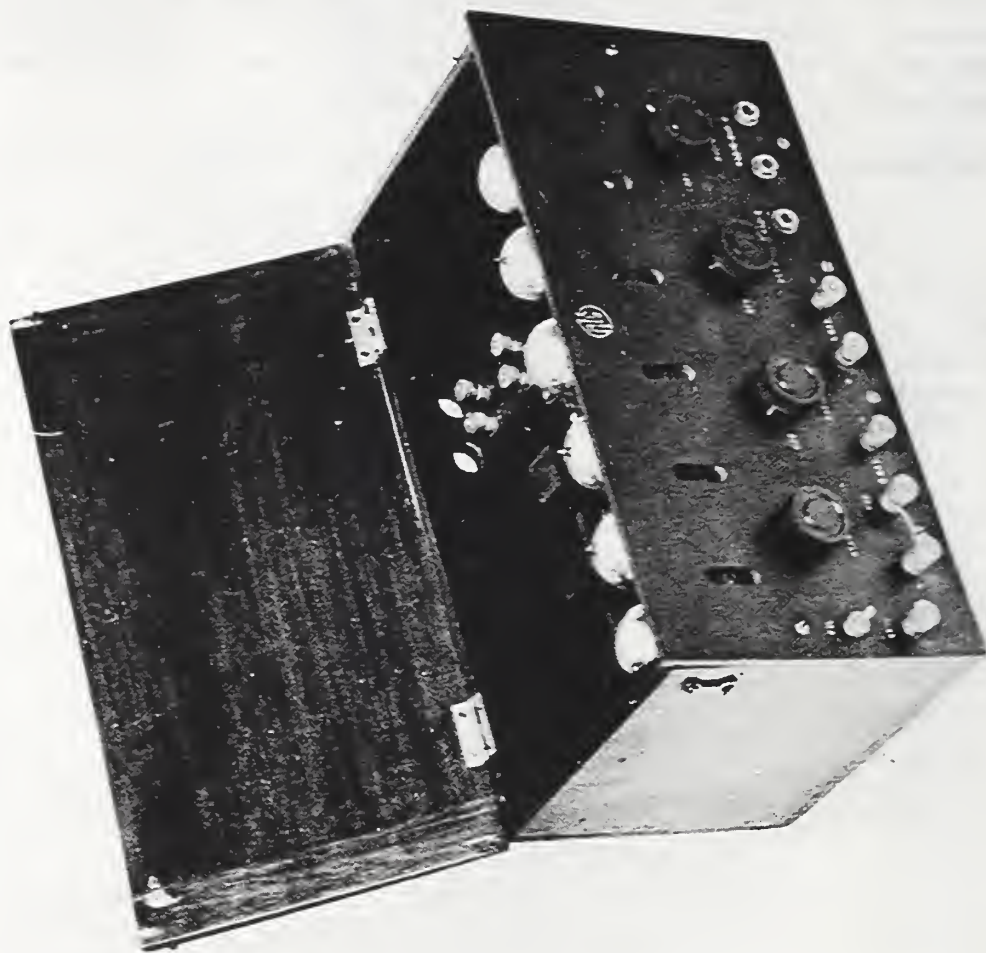

First AC Radio Receiver (1922) M166

Before World War I, "radio" consisted almost solely of wireless telegraphy. The typical spark transmitter emitted a rapid sequence of radiofrequency impulses rather than a continuous wave. The sharper the impulses, the broader the range of frequencies occupied by the emission, and the greater the potential interference with other wireless communication in the same frequency range. To minimize interference, the Department of Commerce enforced regulations limiting the permissible sharpness (the decrement) of the transmitted impulse. F. A. Kolster, working at NBS for Commerce's Bureau of Navigation, developed this instrument, which furnished the transmitter operator with a convenient and reliable means for measuring the emission wavelength (75 to 3000 meters) and for monitoring those transmitter adjustments which fixed the decrement of the impulse.

References

Kolster, F. A., A direct-reading instrument for measuring the logarithmic decrement and wavelength of electromagnetic waves, Nat. Bur. Stand. (U.S.), Sci. Paper 235 (Aug. 1914).

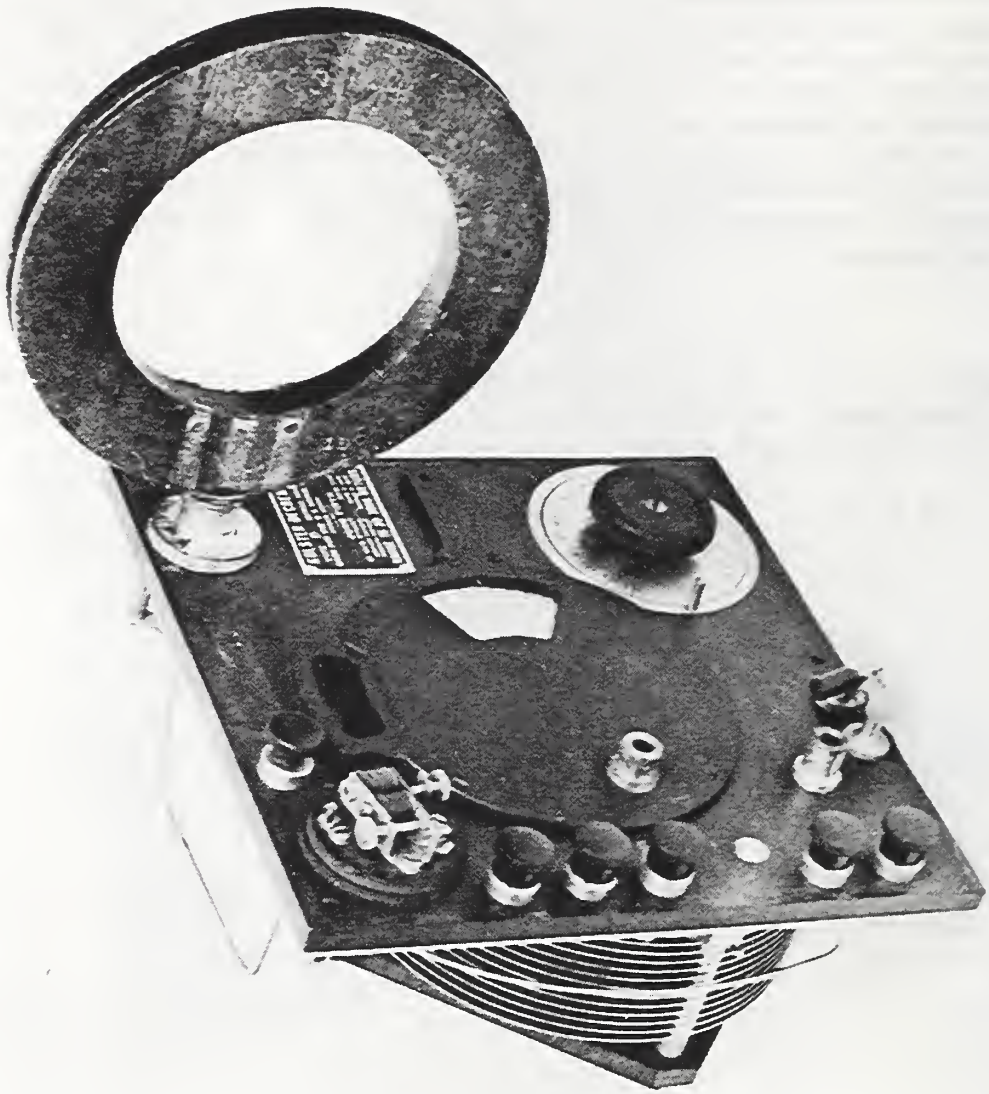

Decremeter (1912) N83

AREA 8 - FLAT CASE Aircraft 

These devices were developed to give an aircraft pilot at a glance a visible indication of whether he was on course as he approached an airfield and if not, which way to turn. A pair of metal reeds were mounted in the center of a coil connected to the airplane radio receiving set. One was tuned to vibrate at 65 hertz and one at 86.7 hertz, and each carried a tiny white vane at its free end. The reeds were excited by a radio beacon developed by NBS and installed on the airfield in College Park, Maryland. Two antennas at right angles sent out waves modulated at 65 and 86.7 hertz respectively, producing in space four channels along which these signals were of equal intensity. When the pilot approached the beacon along one of these channels the vibrating reeds appeared as white lines of equal length. If he flew to the right or left, the right or left line became longer than the other one, indicating that he was off course.

As he flew away from the beacon, the reed housing had to be turned upside down to give the correct indication. In the type C instrument (M86) this was accomplished by a knob and clamp arrangement for TO and FROM. In the type D instrument (M87) the housing was pulled out and plugged in again upside down.

References

- Dunmore, F. W., Design of tuned reed course indicators for aircraft radiobeacon, Nat. Bur. Stand. (U.S.), J. Res. 1, 751 (Nov. 1928).
- Dellinger, J. H., Diamond, H., and Dunmore, F. W., Development of the visual type airway radiobeacon system, Nat. Bur. Stand. (U.S.), J. Res. 4, 425 (Mar. 1930).

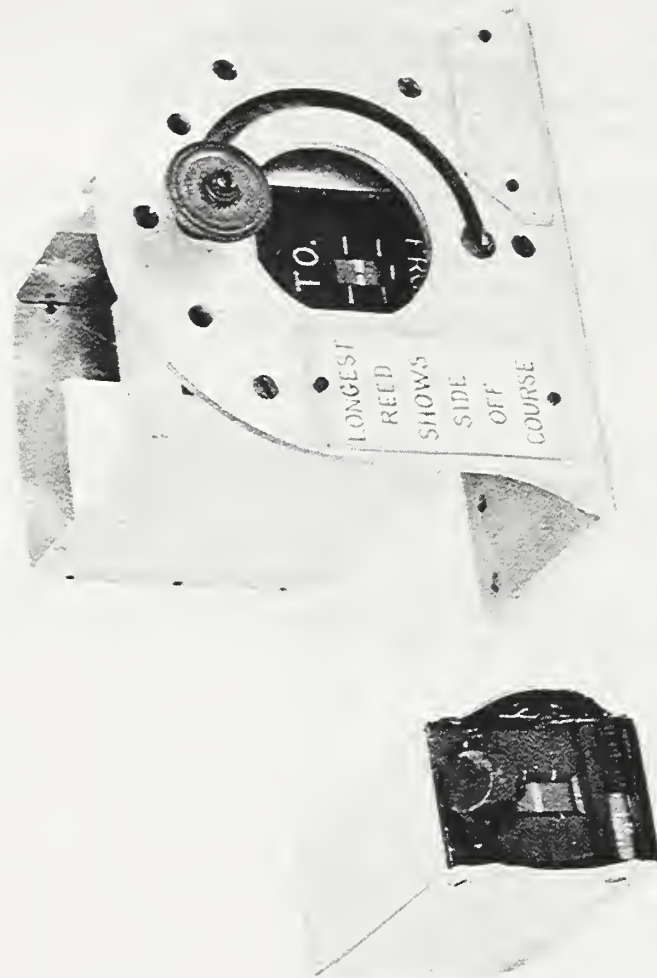

Course Indicator, Two Reed (1928) M86, M87

In 1928 a few radio range beacons had been established for point-to-point flying, but there was urgent need for facilities to permit landings under conditions of poor visibility. The solution developed by an NBS team working for the Aeronautics Division of the Department of Commerce provided for the first time a satisfactory indication of glide path. On the runway, a horizontally polarized radio beam at 100 megahertz was directed at a small angle above the horizontal. On board the plane the signal current in the receiving set was rectified and passed through a dc microammeter. This instrument, called a fog landing glidometer (M85) was turned on its side so that the pointer was horizontal at mid-scale. The pilot flew the plane on a path, approximately parabolic, which kept the received signal at constant intensity as he came in to a landing.

For lateral guidance, a runway localizing beacon was provided. It had 200-watt power and double modulation at 60 and 500 hertz. The two-reed indicator (M87) was replaced by a microammeter of zero-center type, driven by a Dunmore reed converter (M105) and dubbed a runway localizer (M84). Off-course position to right or left was indicated by right or left deflection of the pointer.

In using the final NBS design of a combination instrument (M106) the pilot sought to keep the two pointers crossed within a small circle centered on the dial. Another microammeter, with dial marked from 1 to 5 miles, was operated from the automatic volume control on the signal from the range beacon, and showed him the approximate distance to the point of touchdown.

Many experimental landings were made successfully during 1933 with use of the beacons and indicators of the NBS system, both at College Park, Maryland and at Newark, New Jersey.

References

- Diamond, H. and Dunmore, F. W., A radiobeacon and receiving system for blind landing of aircraft, Nat. Bur. Stand. (U.S.), J. Res. 5, 897 (Oct. 1930).
- Dunmore, F. W., A course indicator of pointer type for the visual radio range beacon system, Nat. Bur. Stand. (U.S.), J. Res. 7, 147 (July 1931).
- Diamond, H., Performance tests of radio system of landing aids, Nat. Bur. Stand. (U.S.), J. Res. 11, 463 (Oct. 1933).

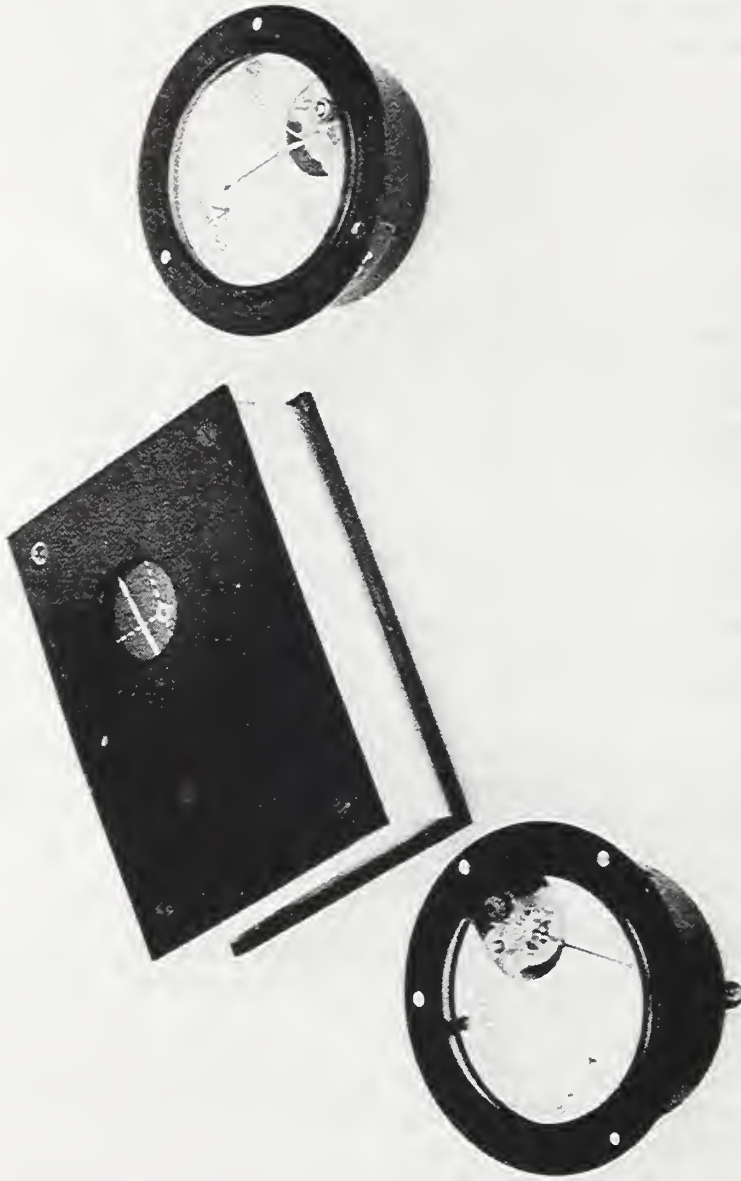

Instrument Landing Devices (1930)
Glidometer M85; Combined Landing Instrument M106; Runway Localizer M84

AREA 9 - FLAT CASE

Electricity



By use of resistance thermometers in favorable circumstances, temperature measurements can be made with an uncertainty of less than 0.001 kelvin; in the measurement of small temperature changes, as in calorimetry, uncertainties of 0.0001 kelvin or less can be achieved. The first Wheatstone bridge used for resistance thermometry at NBS (No. 1648) was designed by Waidner and Wolff in 1901. Experience dictated improvements, and the design of M290 in 1910 by E. F. Mueller required that (a) the coils be hermetically sealed, (b) connecting switches and links as well as coils be immersed in the thermostated oil bath, (c) the operating mechanism be rigidly aligned (substituting marble for hard rubber), (d) the variable resistance arm consisting of six decades (with mercury-cup contacts for links in the first three, and shunted Waidner-Wolff elements for the last three), (e) the construction permit readings to be made with an imprecision within 2 or 3 percent of one step in the last decade.

This instrument, known in the Thermometry Laboratory as the "Marble Top" was constructed by the Leeds and Northrup Co. and delivered in 1912. It was used by Dickinson in combustion calorimetry, in studies of the thermal properties of ammonia, and in many other applications until it was retired in the 1930's.

References

Waidner, C. W., Dickinson, H. C., Mueller, E. F., and Harper, D. R., A Wheatstone Bridge for Resistance Thermometry, Bull. Nat. Bur. Stand. 11, 571 (1915).

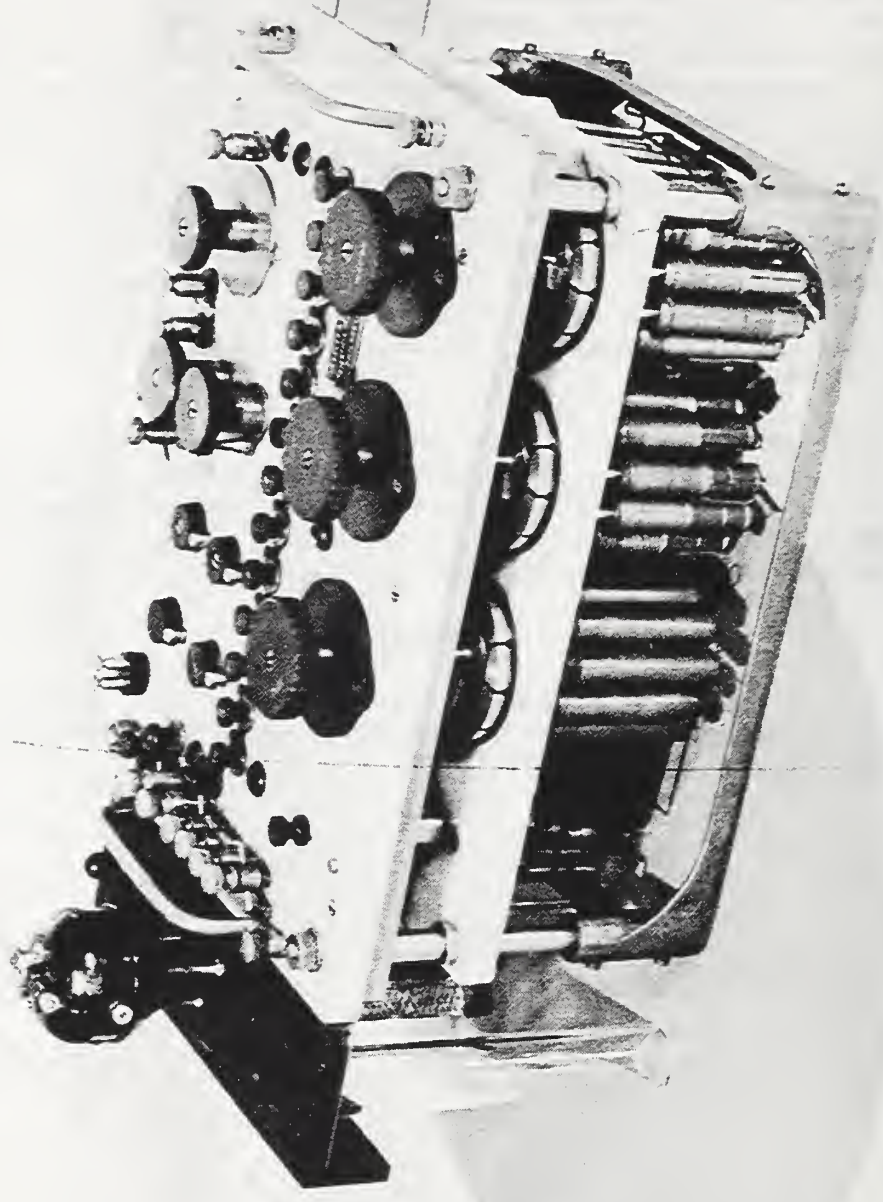

Bridge for Resistance Thermometry (1910) M290

This instrument was the first of a series of ac-dc transfer standards developed by F. L. Hermach, which greatly improved the accuracy of ac measurements at audio frequencies. The thermoconverter element (in the small black box at one end) consists of a straight-wire heater mounted in a ceramic bead with a thermocouple which responds to its temperature rise. The element is housed in an evacuated glass envelope, and is connected in series with a commercially available shielded resistor of 5 decades. The output emf of the thermocouple (6 millivolts for a 20 milliamper heater current) is measured by an elementary form of deflection potentiometer. It is the same to within less than 0.01 percent with the same level of either dc or ac voltage applied to it. It can thus be used with dc standards to measure ac voltages or currents, at frequencies between 25 and 20,000 Hz.

Model A was constructed in 1947, used steadily until 1953, and then intermittently until 1960, when it was superseded by newer models.

References

- Hermach, F. L., A precision electrothermic voltmeter, Trans. AIEE 67, No. 2, 1224 (1948).
- Hermach, F. L., Thermal converters as ac-dc transfer standards, Nat. Bur. Stand. (U.S.), J. Res. 48, 121 (1952).

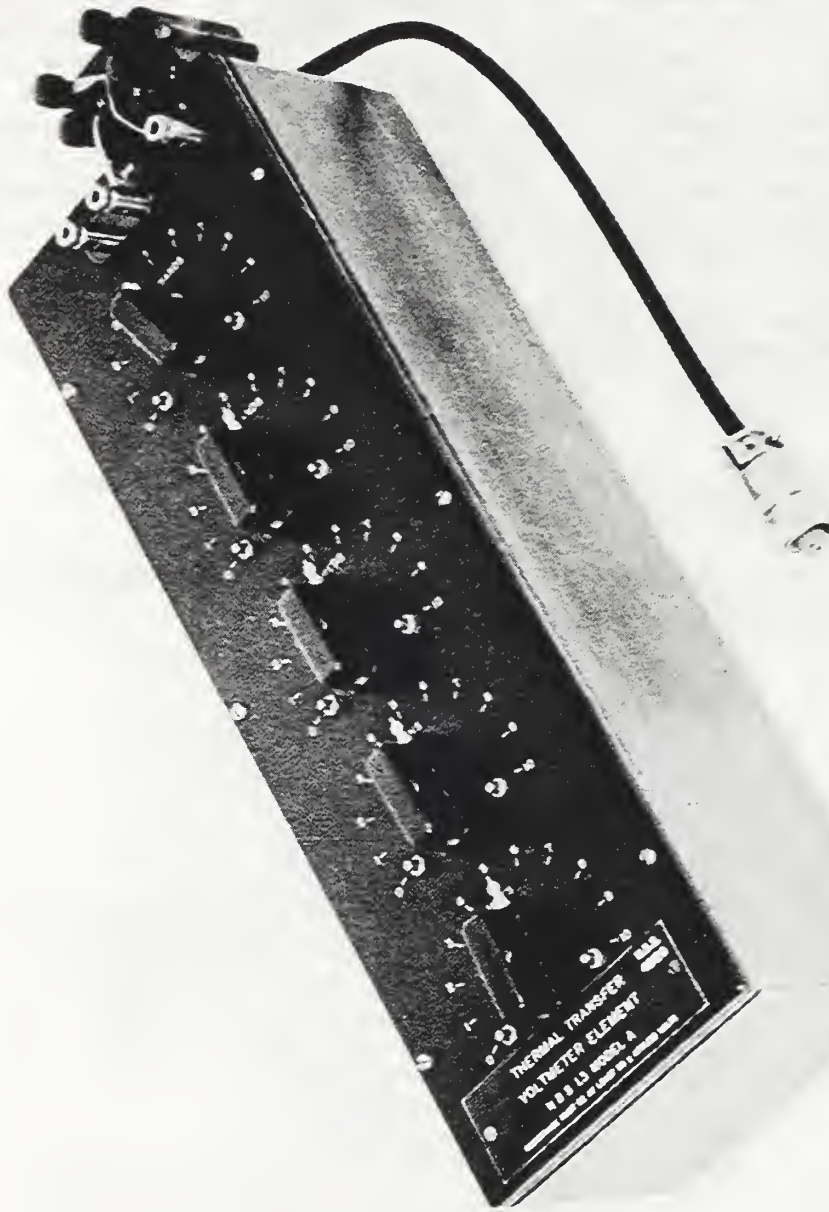

Electrothermic Voltmeter (1947) M313

Each of the four independent circuits in this shunt box consists of a Waidner-Wolff 10-step adjustable element.

The Waidner-Wolff resistance element was devised at NBS by C. W. Waidner and F. A. Wolff in 1902. It consists of a small fixed resistance shunted by a much larger resistance that is variable in ten unequal steps so chosen that the resultant parallel combination is varied in ten equal steps; for the highest step the shunt resistance may be infinite. This arrangement eliminates the effect of switch-contact resistances from the decade, and permits construction of decades whose steps may be as small as 1 micro-ohm or as large as 0.1 ohm. A second advantage of the arrangement is the suppression of parasitic thermal emfs in the circuit.

The instrument was purchased from O. Wolff of Berlin in 1903. It seems probable that in an early application its four circuits were shunted around four graded resistors in one ratio arm of a bridge circuit.

Waidner, C. W. and Dickinson, H. C., Apparatus for platinum resistance thermometry, *Phys. Rev.* 19, 51 (1904).

Mueller, E. F. and Wenner, F., The Waidner-Wolff and other adjustable electrical resistance elements, *Nat. Bur. Stand. (U.S.), J. Res.* 15, 477, RP842 (1935).

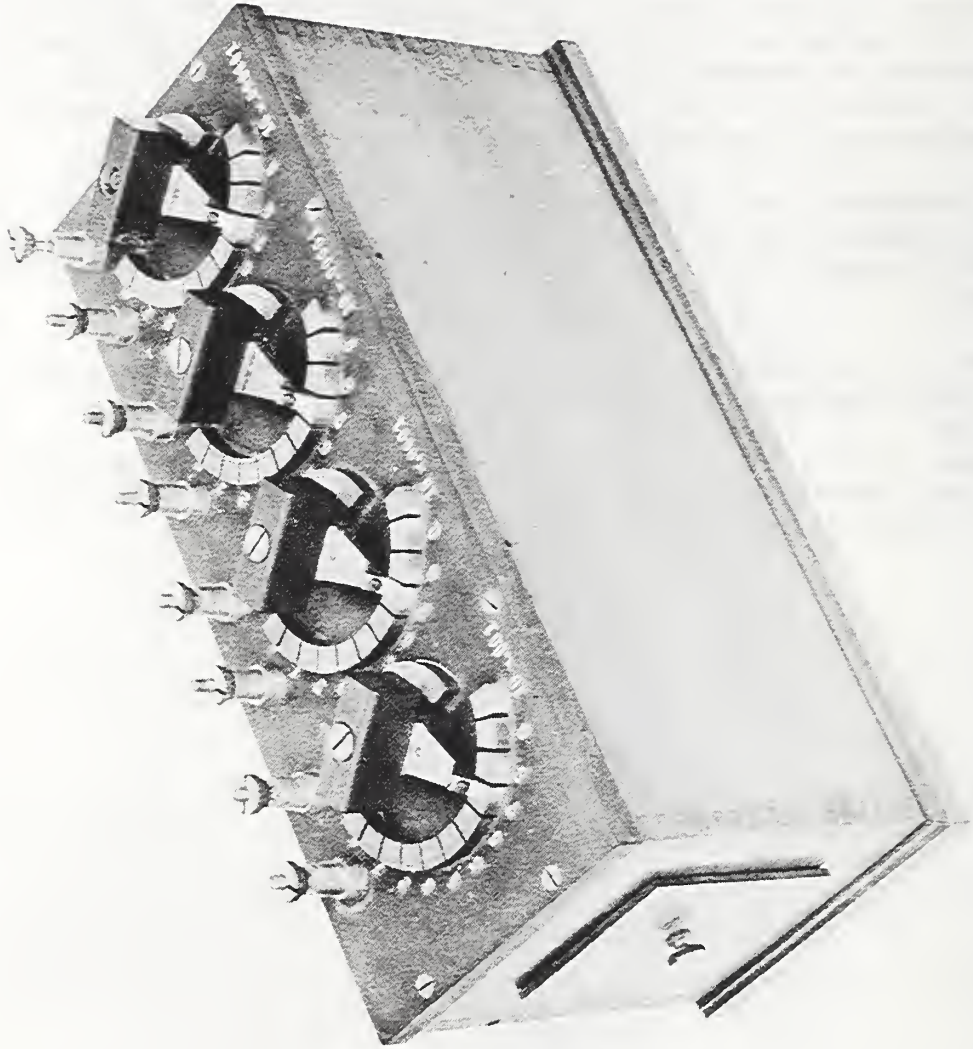

Shunt Box, Waidner-Wolff (1902) M393

This noninductive shunt, with a range of 0.025 to 0.11 ohms, was designed by P. G. Agnew for the secondary circuit of a current transformer under test for ratio and phase angle. Projecting from the two binding posts at the left is a manganin strip folded over thin mica, one of several with fixed values of 0.025, 0.035, 0.045, etc., ohm. Two curved manganin strips separated by thin mica provide adjustable resistance between the two movable arms (potential terminals). The inner one, connected by taps to the 10 numbered studs, gives steps of 0.001 ohm. The outer one, projecting half a millimeter above the other, has a total resistance of 0.001 ohm and by estimating to tenths of its 10 divisions, 0.00001 ohm can be read. Current terminals are located at the right, with connection through a straight copper strip. At 60 hertz the phase angle of the shunt is less than one minute. After its use in the classic study of 1909, the instrument served for calibration testing of current transformers until 1916, when superseded by resistor M96 having wider strips.

References

- Agnew, P. G. and Fitch, T. T., The Determination of the Constants of Instrument Transformers, Bull. Nat. Bur. Stand. 6, 281 (1909-10).
- Agnew, P. G., A Study of the Current Transformer with Particular Reference to Iron Loss, Bull. Nat. Bur. Stand. 7, 428 (1911).

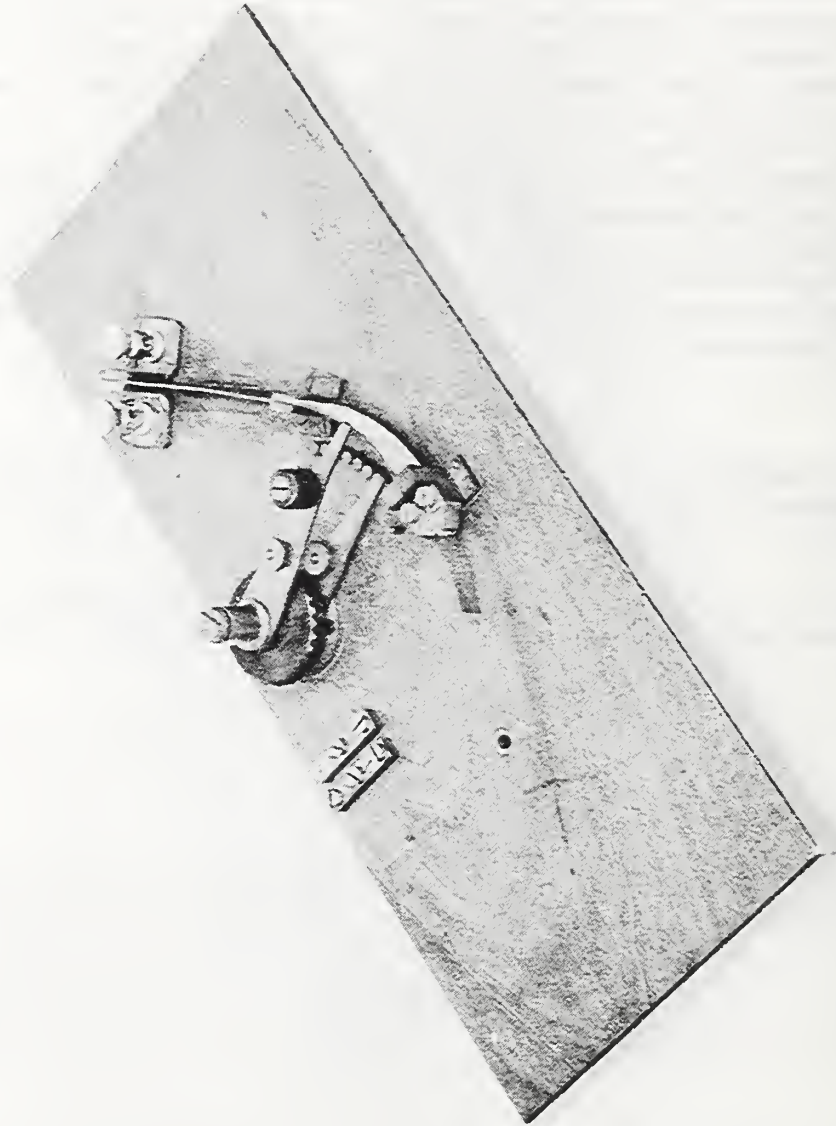

Resistor, Adjustable Noninductive (1909) M97

In this type of standard resistor developed by J. L. Thomas a single layer of bifilar manganin wire is wound on a mandrel and annealed in a vacuum at red heat. It is then slipped onto a silk-insulated 6-cm brass cylinder with only loose contact between them. This tube is closed by soldering its flanged ends to an outer 7-cm tube. The coil is sealed in place with dry air and the leads for electrical connections are brought out through seals.

Previous to 1910 the U.S. reference standard of electrical resistance was maintained by resistors of the Reichsanstalt type (M293) obtained from Germany. From 1910 to 1930 the standard was a group of 10 one-ohm coils of a design of E. B. Rosa (M28). Between 1930 and 1939 these were gradually replaced by the double-walled type. The maximum net change of the latter group, with respect to the mean of the ten, measured at yearly intervals from 1939 to 1969, has been only one part per million.

References

- Thomas, J. L., A new design of precision resistance standard, Nat. Bur. Stand. (U.S.), J. Res. 5, 295 (Aug. 1930).
- Thomas, J. L., Stability of double-walled manganin resistors, Nat. Bur. Stand. (U.S.), J. Res. 36, 107 (Jan. 1946).
- Wells, T. E., Precision Measurement and Calibration, Vol. 3, Electricity-Low Frequency, Nat. Bur. Stand. (U.S.), Spec. Publ. 300, 139-111 (Dec. 1968).

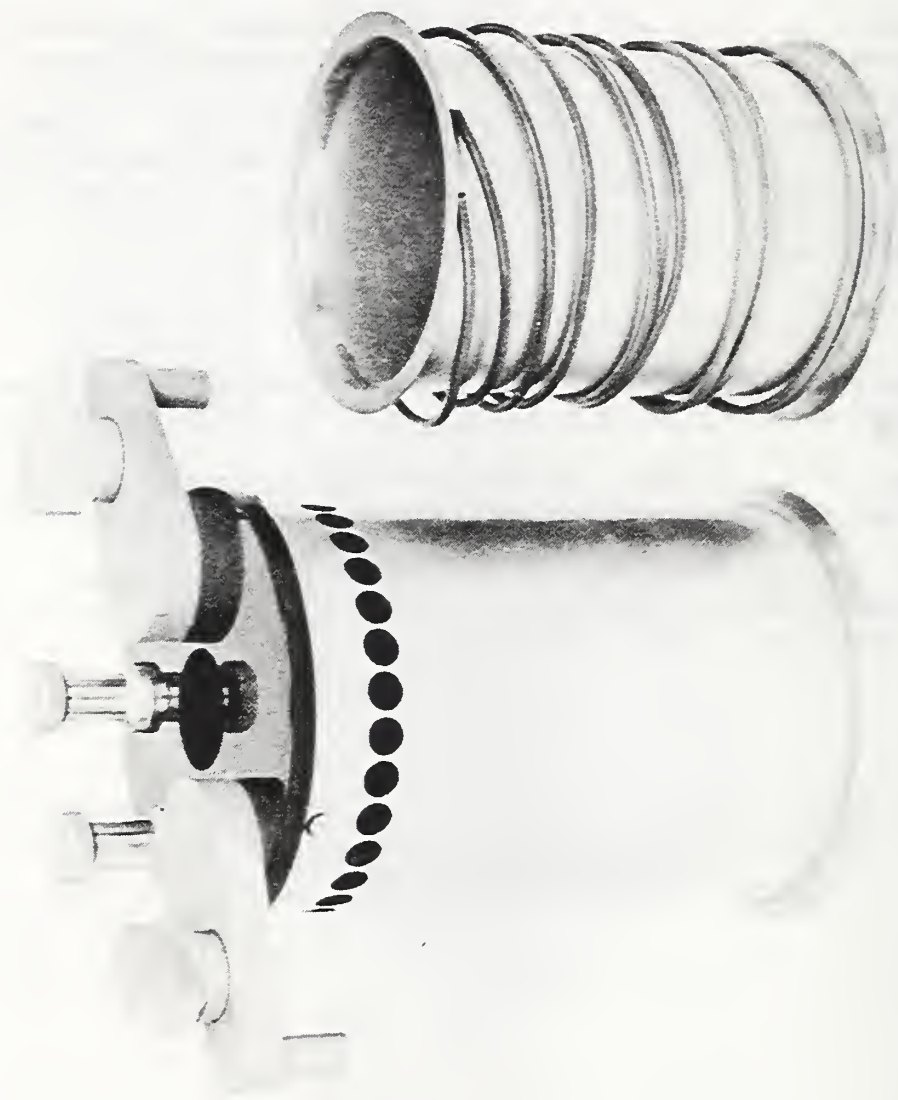

One-Ohm Resistor, Double-Walled (1930) M42

The classic method for determination of the faraday involves the electrolytic deposition of silver on platinum from an aqueous solution of silver nitrate, but it is subject to uncertainty because of possible foreign occlusions in the deposit. The apparatus shown here electrolytically oxidizes a silver anode (shown at the right) in an aqueous perchloric acid solution. The platinum cathode is at the left, and the intermediate beakers and siphons serve to collect any mechanically detached silver particles. In the test tube at the right was placed a reference silver anode for checking the electrolytic potential at the dissolving anode.

Currents of 0.1, 0.2, 0.3, and 0.5 amperes (typically 0.20363887 A) were used in 31 runs under various conditions for durations of 3 hours or more, known to within 1 ppm. The number of ampere-seconds needed to dissolve a given weight of silver was found to be $1.117972 \text{ mg coulomb}^{-1}$ with an overall uncertainty of 19 ppm. With 107.9028 ± 0.0013 for the atomic weight of silver as measured with the mass spectrometer, the faraday was determined to be $96,516.5 \pm 2.4 \text{ coulombs g-equivalent}^{-1}$ (physical scale).

References

- Craig, D. N., Hoffman, J. I., Law, C. A., and Hainer, W. J., Determination of the value of the faraday with a silver-perchloric acid coulometer, Nat. Bur. Stand. (U.S.), J. Res. 64A, 381 (1960).
- Shields, W. R., Craig, D. N., and Dibeler, V. H., J. Am. Chem. Soc. (Sept. 1960).

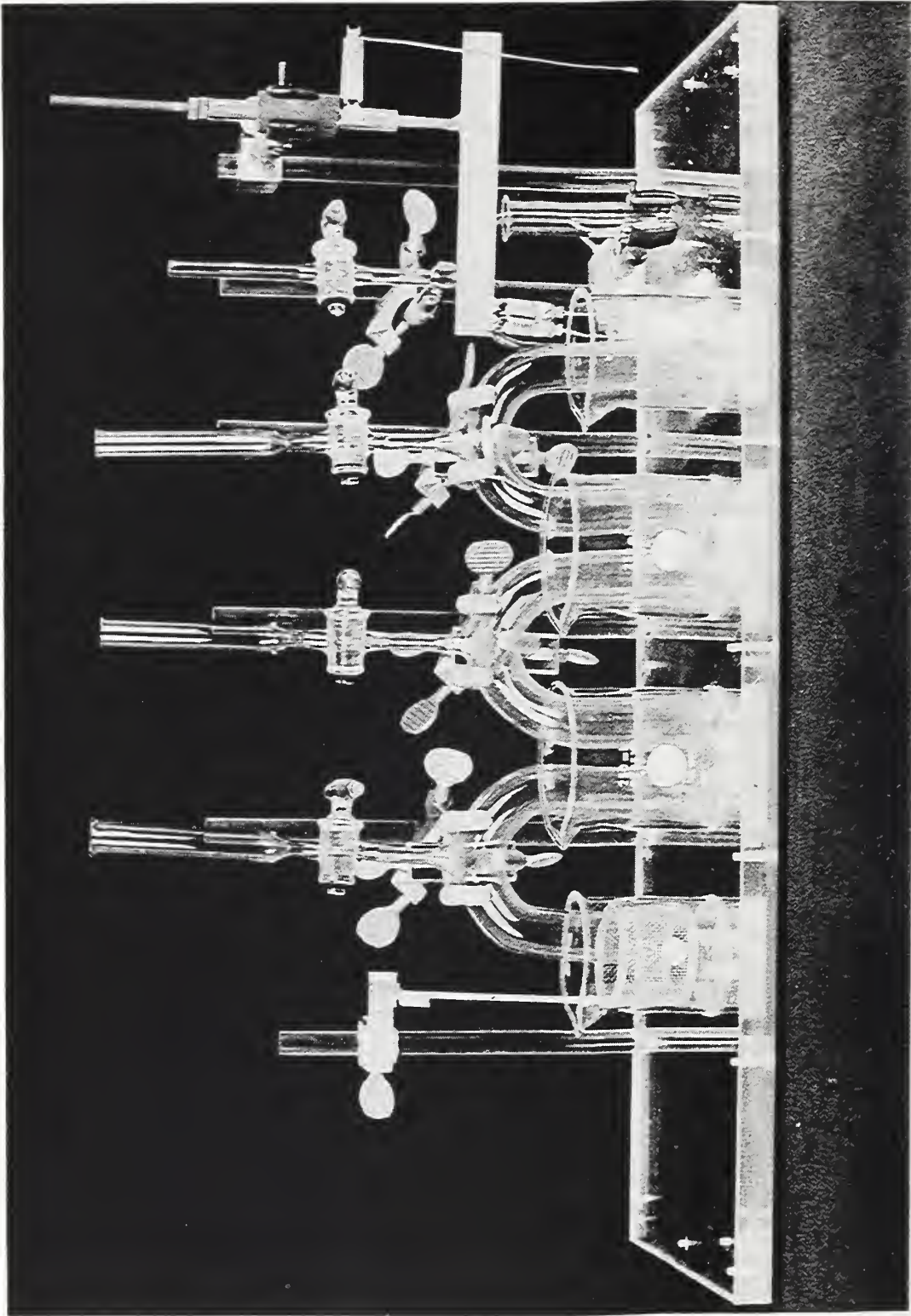

Coulometer, Perchloric Acid (1957) M176

In ac measurements where null methods are employed, maximum sensitivity of the detector is obtainable by tuning the moving element so that its natural period is the same as that of the electrical circuit. In this instrument designed by P. G. Agnew and improved by J. H. Pim and R. D. Wyckoff, the moving element is a fine steel wire polarized by being mounted on one pole of a permanent magnet. A small electromagnet, energized from the circuit in which current is to be detected, carries pole pieces in the shape of truncated pyramids which stand on either side of the free tip of the wire reed. Resonance frequency of the reed, largely dependent on the length and stiffness of the wire, is adjustable through a small range by shifting the position of the electromagnet poles with respect to the tip of the wire.

Resonant vibration of 5 micrometres is easily observable through the microscope, and a current of 0.05 microampere or an emf of 3 microvolts can be detected. Galvanometers of this type were used in all precise calibration of standard voltage transformers at NBS from 1919 until about 1945, when electronic methods were adopted.

References

- Wenner, F., A Theoretical and Experimental Study of the Vibration Galvanometer, Bull. Nat. Bur. Stand. 6, 347 (1909-10).
- Agnew, P. G., A new form of vibration galvanometer, Nat. Bur. Stand. (U.S.), Sci. Papers 16, 37 (1920).

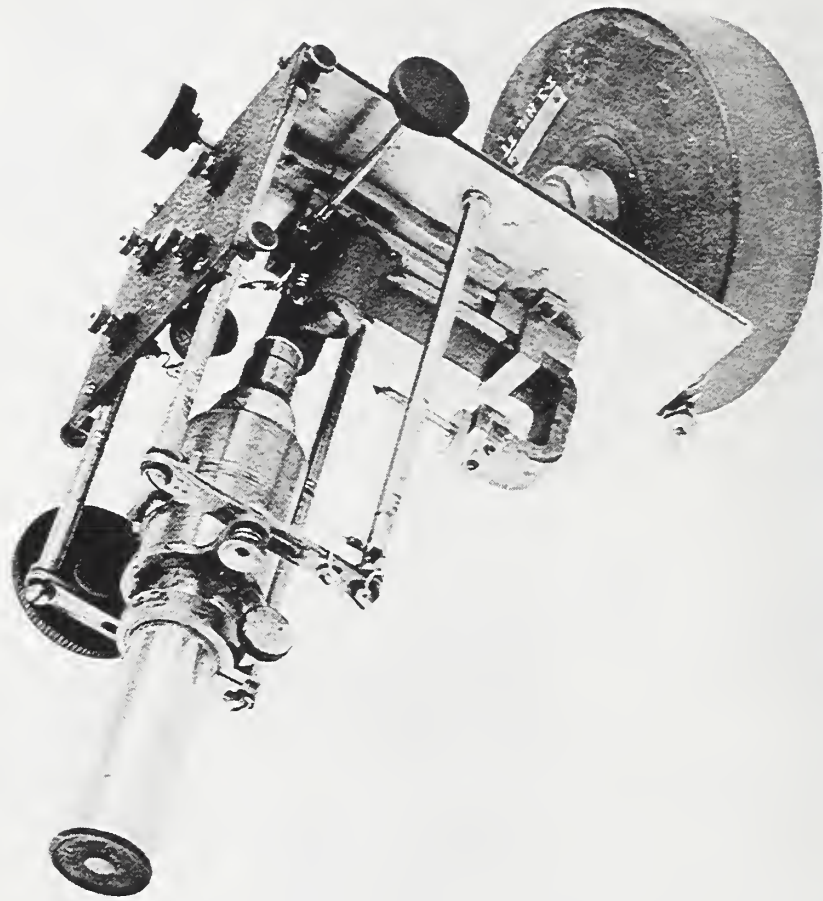

Galvanometer, Vibrating Reed (1919) M98

This taut-suspension galvanometer has its center of gravity displaced behind the axis of rotation determined by the suspension strips, introducing an element of gravity control into the central moment of the moving system. Thus tilting the instrument altered the gravity component of the moment and changed the effective stiffness of the suspensions and hence the sensitivity, period, and external critical damping resistance of the galvanometer. With a sensitivity of 22 mm/ μ v on a scale 150 cm distant, its period is 10 sec and its cdx is 80 ohms.

This galvanometer was designed about 1910 by Frank Wenner, who treated the coil with copper chloride to minimize the magnetic dust inclusions that give rise to zero instability.

Galvanometers of this type, used for a number of years in the resistance laboratory at the old NBS site, are very susceptible to mechanical disturbances; these disturbances, transmitted to the galvanometer wall mount from increasingly heavy neighborhood traffic, finally led to their abandonment.

References

Wenner, F., General Design of Critically Damped Galvanometers, Bull. Nat. Bur. Stand. 13, 211 (1916-17).



Galvanometer, Adjustable Sensitivity (1910) M39

This miniature instrument is one of several constructed by W. W. Coblentz for his work on radiometry. There are two sets of two flat-faced 20-ohm current coils each wound on a special mandrel with 0.07, 0.127, and 0.199-mm pure copper wire. Each has an external diameter of 32 mm and the internal diameter of 2 mm. The needle system, suspended on a quartz fiber from the top of the 8-mm tube, consists of two sets of 6 tungsten steel magnets, $1.2 \times 0.2 \times 0.1$ mm, arranged astatically. The sensitivity achieved was 2.5×10^{-11} ampere for a full period of 36 seconds. The coils are completely covered with chamois to exclude air currents, but the deflection of a mirror mounted on the glass staff between the magnet sets can be viewed through the small window on the right. The set of three soft iron shields shown at the rear (upside down) were used to reduce the effect of external magnetic fields.

There was a considerable demand for these instruments; from 1920 to 1940 they were manufactured by Leeds and Northrup Co. to Coblentz specifications.

References

Coblentz, W. W., Instruments and Methods Used in Radiometry, Bull. Nat. Bur. Stand. 4, 391 (1907-8); 9, 7 (1931).

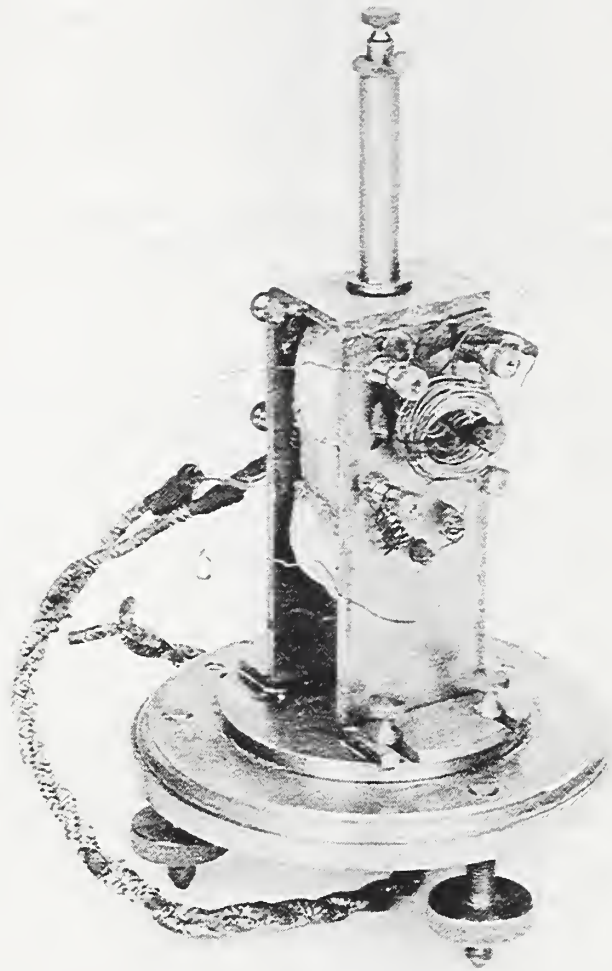

Galvanometer, Moving Magnet (1907) M219

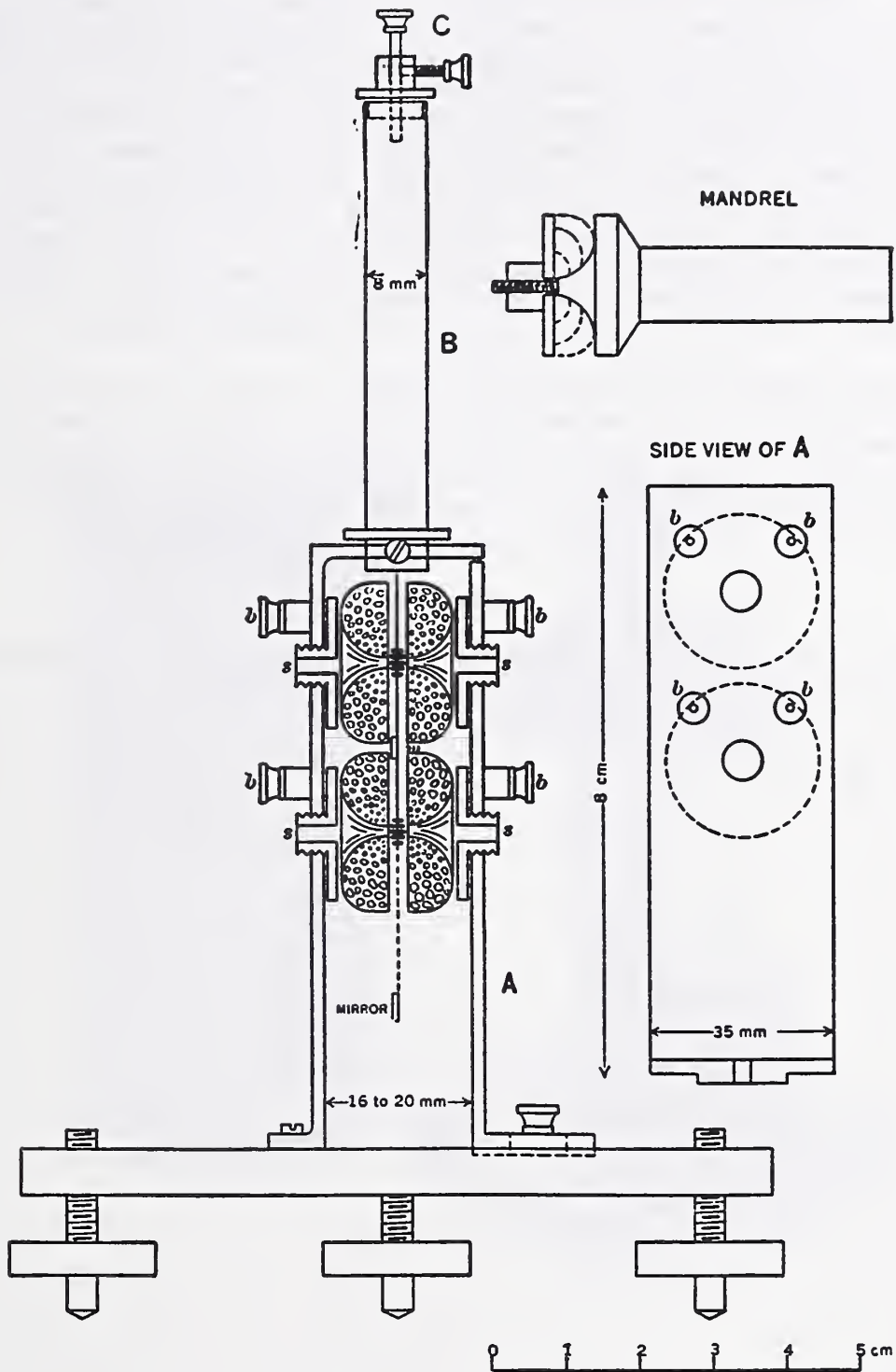

Schematic drawing of Galvanometer, Moving Magnet (1907) M219

This form of vibration galvanometer (D'Arsonval type) was invented by F. B. Silsbee. The moving coil, suspended between shaped polepieces of the large permanent magnet, consists of 10 turns of wire stretched taut between suspensions of copper strip. A rough adjustment of the natural frequency is obtained by adjusting the distance between the clamps which hold the suspensions. A fine adjustment of tuning to resonance with the circuit under study can be accomplished by an observer while he watches the oscillation amplitude of the mirror. The lower end of the lower suspension carries a small soft iron plunger which hangs partly inside a solenoid. Adjustment of the direct current flowing in this solenoid changes the tension and thus the natural frequency.

At resonance the sensitivity is about 0.3 mm per microvolt at a scale distance of one meter. The iron case (set at one side) gives protection from air currents and stray magnetic fields. The instrument was used as an ac detector in the precise calibrations of ratio and phase angle of standard current transformers for 25 hertz, until superseded by an electronic detector about 1935.

References

- Silsbee, F. B., et al., Equipment for testing current transformers, Nat. Bur. Stand. (U.S.), J. Res. 11, 114 (1933).
- Wenner, F., Characteristics of vibration galvanometers, Proc. AIEE 31, 1073 (1912).

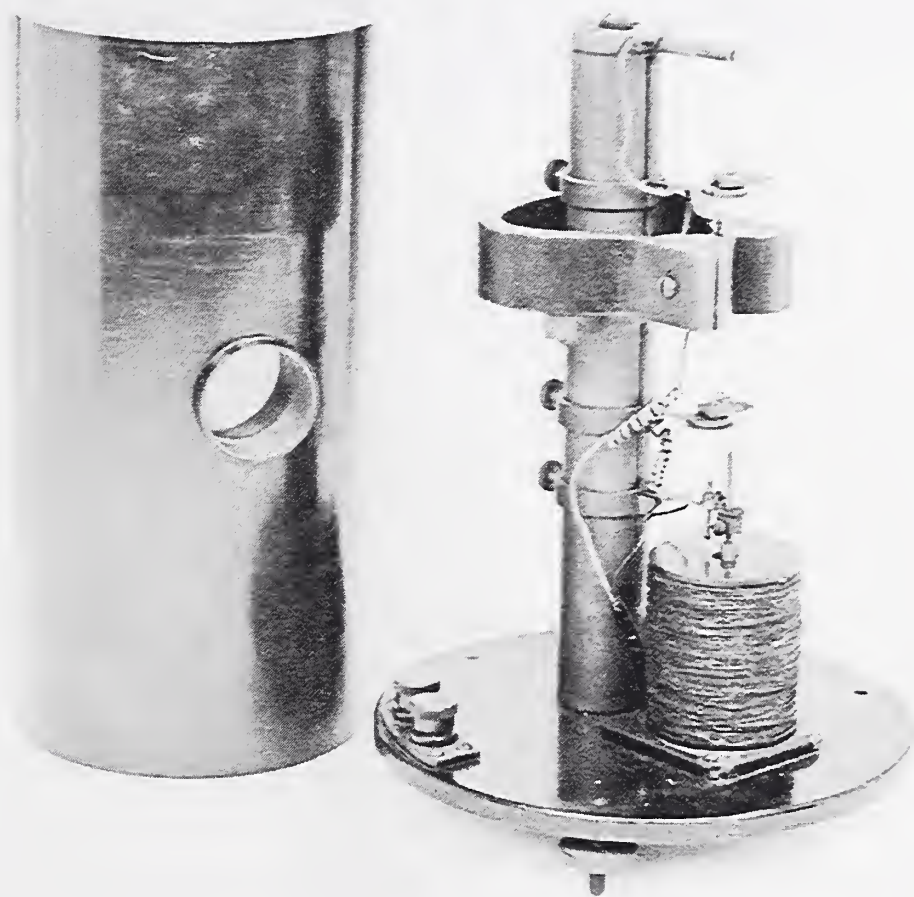

Galvanometer, Remotely Tuned (1933) M95

An early form of this simple dc instrument, which Friedrich Kohlrausch called a spring galvanometer, was described in 1884. A magnetized rod (or a soft iron tube) is suspended by a weak spring, with part of its length extending into a current-carrying coil. As the current is increased, the core is pulled further into the coil, and its position is indicated on a scale marked in amperes. The accuracy claimed was about 10 percent.

The model shown was imported about 1900 by Queen & Co. of Philadelphia, and was later presented to H. B. Brooks of NBS by S. Krasnow of the Georator Co.

References

Kohlrausch, F., Über ein Federgalvanometer für technische Zwecke, Elektrotechn. Zeitschr. 5, 13-20 (1884); Über einen einfachen absoluten Strommesser für schwache electricische Ströme, Ann. Physik, Series 3, Vol. 27, 403-409 (1886).



Ammeter, Kohlrausch (1885) M103

NONREACTIVE RESISTORS

Several NBS staff members were pioneers in developing special windings in which the turns were frequently reversed in direction to minimize inductance or capacitance in resistors used on alternating current. Later, manufacturers developed looms for weaving such resistors.

CURTIS WINDING

1912

M53

These two resistors, each of 1000 ohms, are wound with 0.05 mm manganin wire on a slitted porcelain cylinder so that successive turns lead the current around the form in opposite directions. Thus the inductance is reduced to +30 microhenrys, while the difference of potential between adjacent turns, and hence the effective capacitance, is much smaller than in the more usual bifilar winding.

References

Curtis, H. L. and Grover, F. W., Resistance Coils for Alternating Current Work, Bull. Nat. Bur. Stand. 8, 495 (1912).

WENNER WINDING

1930

M454

This construction by which the inductance can be kept very low was suggested by Frank Wenner. A small flexible core of insulating material about 1 mm diameter is mounted parallel and close to the main rigid ceramic core. After a few turns of resistance wire have been wound around the main core, one turn is looped around the small core. This starts the winding on the main core in the reverse direction.

The resistor can be made much more quickly than the Curtis type (M53), but puts more strain in the wire at the small loops.

MOON WINDING

1935

M52

This resistor is a modification of the Curtis type, in that the direction of winding is reversed at every 12th turn, the wire passing through holes in the grooved insulating form. It is one of a group constructed by Charles Moon to serve as arms in the Maxwell-Wien ac bridge used in his absolute determination of the ohm. The residual inductance is about 60 microhenrys for a 1000-ohm coil.

References

Curtis, H. L., Moon, C., and Sparks, C. M., An absolute determination of the ohm, Nat. Bur. Stand. (U.S.), J. Res. 16, 28 (1936).

WOVEN AND CARD TYPES

1940

M50

In a machine-woven "fabric" tape by the Leeds and Northrup Co. the resistance wire forms the filling, the warp thread being textile. A 10,000-ohm and a 1000-ohm resistor are supported mechanically by being wrapped around insulating cylinders.

The other 1000-ohm coil is of wire wound on a thin flat insulating card.

References

Curtis, H. L. and Grover, F. W., Resistance Coils for Alternating Current Work, Bull. Nat. Bur. Stand. 8, 495 (1912).

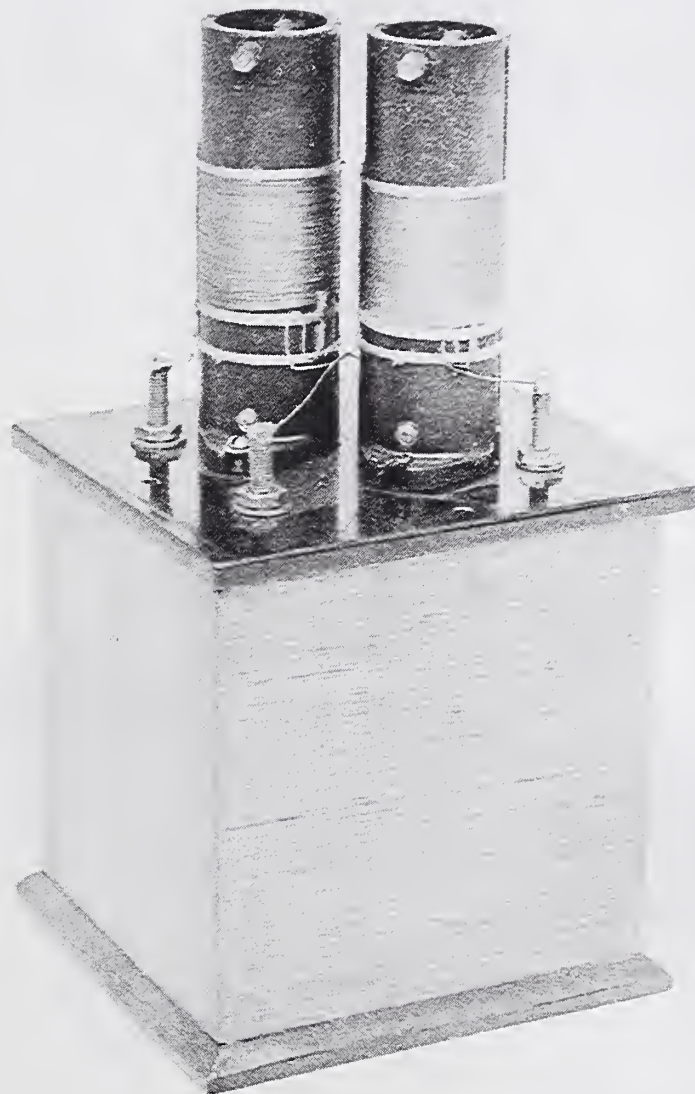

Nonreactive Resistor, Curtis Winding (1912) M53

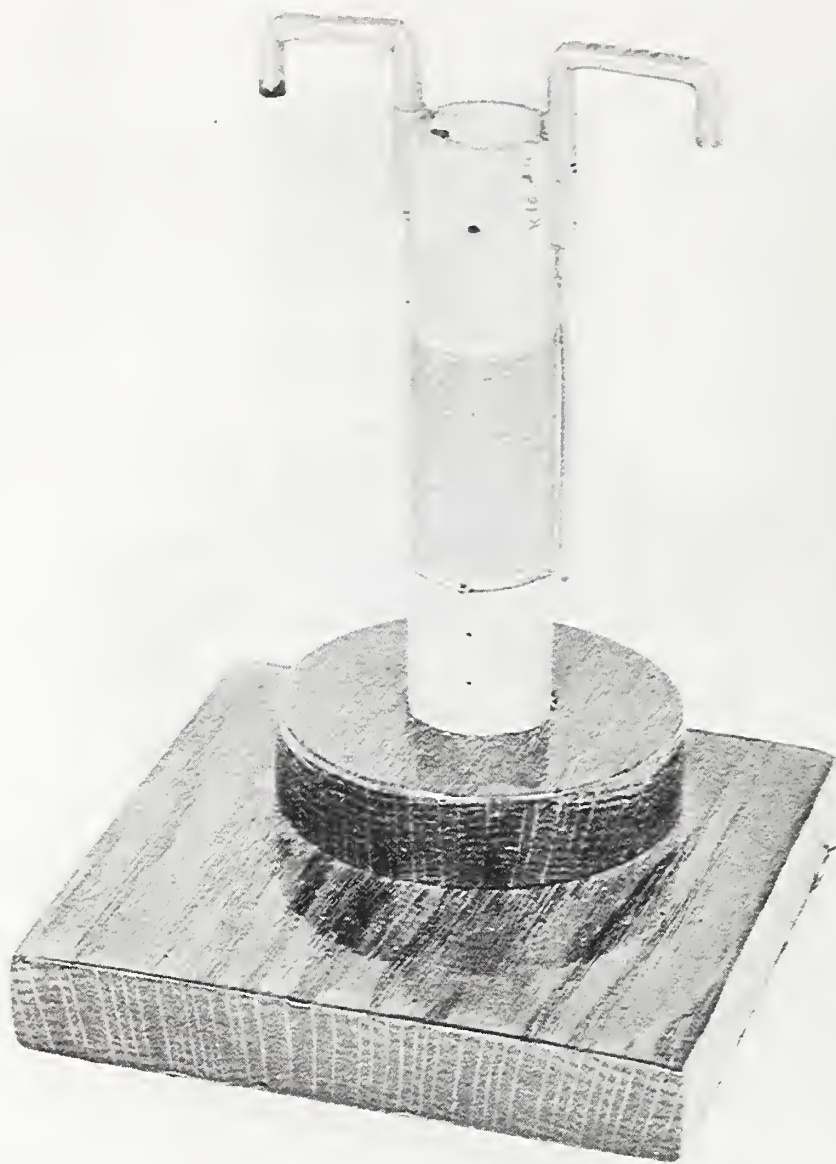

Nonreactive Resistor, Wenner Winding (1930) M454



Nonreactive Resistor, Moon Winding (1935) M52

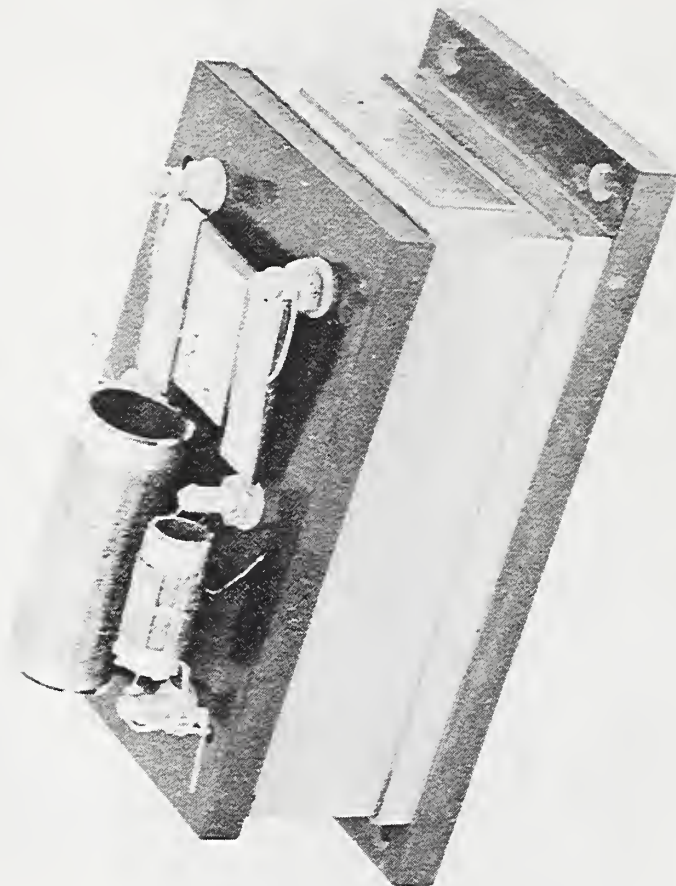

Nonreactive Resistors, Woven and Card Types (1940) M50

This is a secondary standard for use in calibrating ac ammeters up to 500 amperes. It was designed by Lord Kelvin and purchased by NBS in 1902 from Kelvin & White, Glasgow. As described by F. A. Laws, "There are four fixed and two movable coils, the latter being carried at the ends of a balance arm which turns about a horizontal axis. Each movable coil is situated between two fixed coils and all six coils are connected in series. In place of a knife edge, the beam is suspended by a large number of filaments of copper wire, forming a sort of stranded ribbon, which provides a ready means for making the electrical connection to the movable coils. Absence of friction, large radiating surface, and cooling by conduction to the frame are the advantages attained by this means."

A uniformly graduated scale, with its zero at the left end, is attached to the suspended coil system, and carries a shelf on which weights can be placed in the V-shaped trough attached to the right-hand end. When current flows through the six coils the total moment due to the weights can be balanced against the force exerted on the movable coils, which is proportional to the square of the current.

References

Laws, F. A., Electrical Measurements, 1st edition, p. 92 (McGraw Hill, 1917).

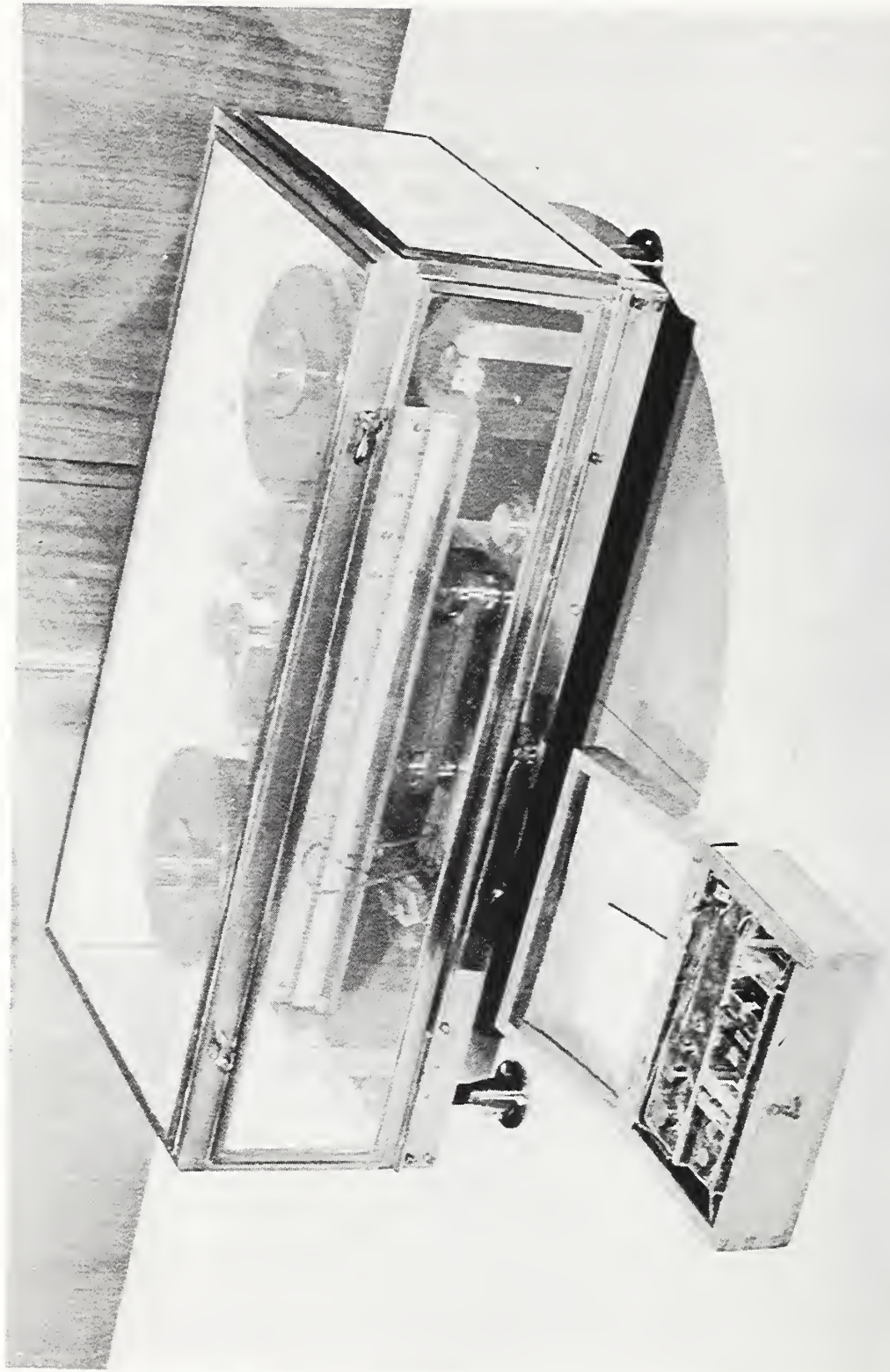

Current Balance, Kelvin (19C2) M89

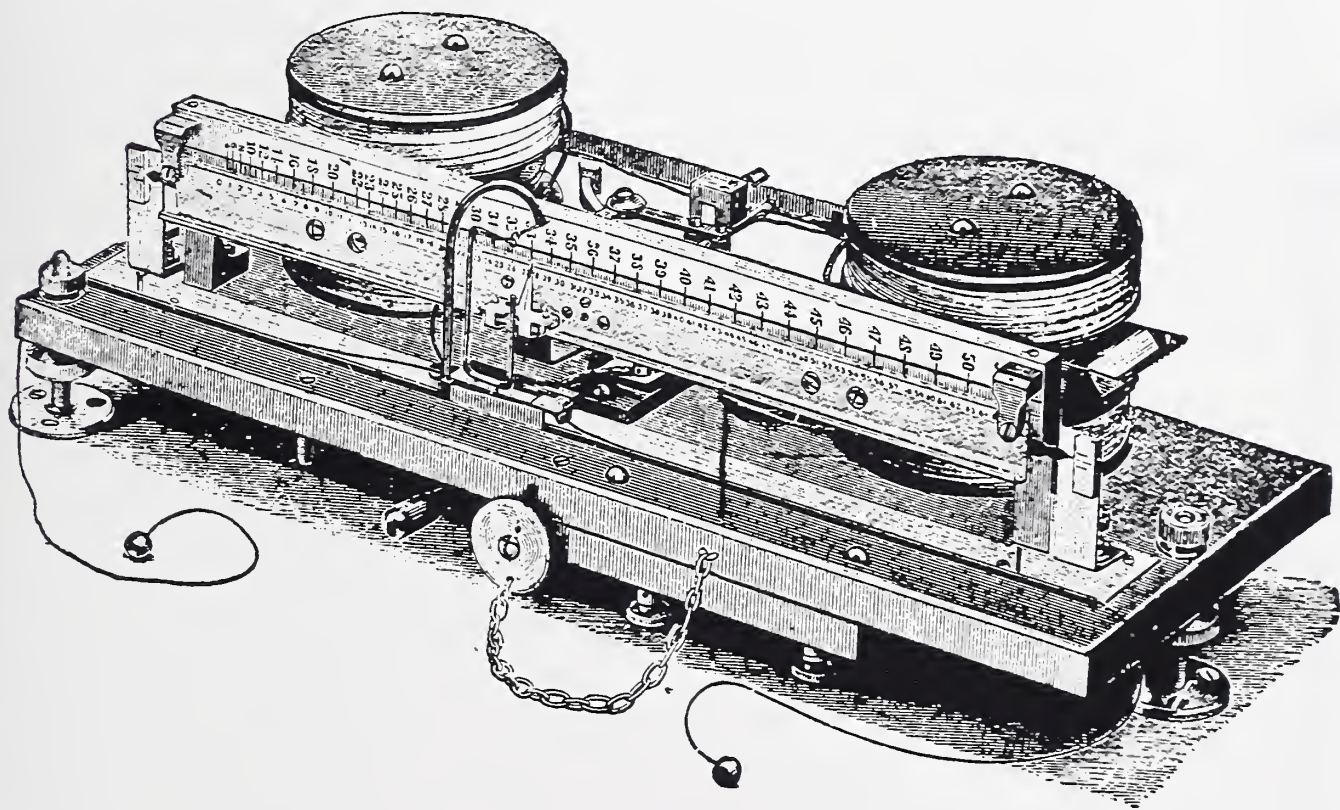
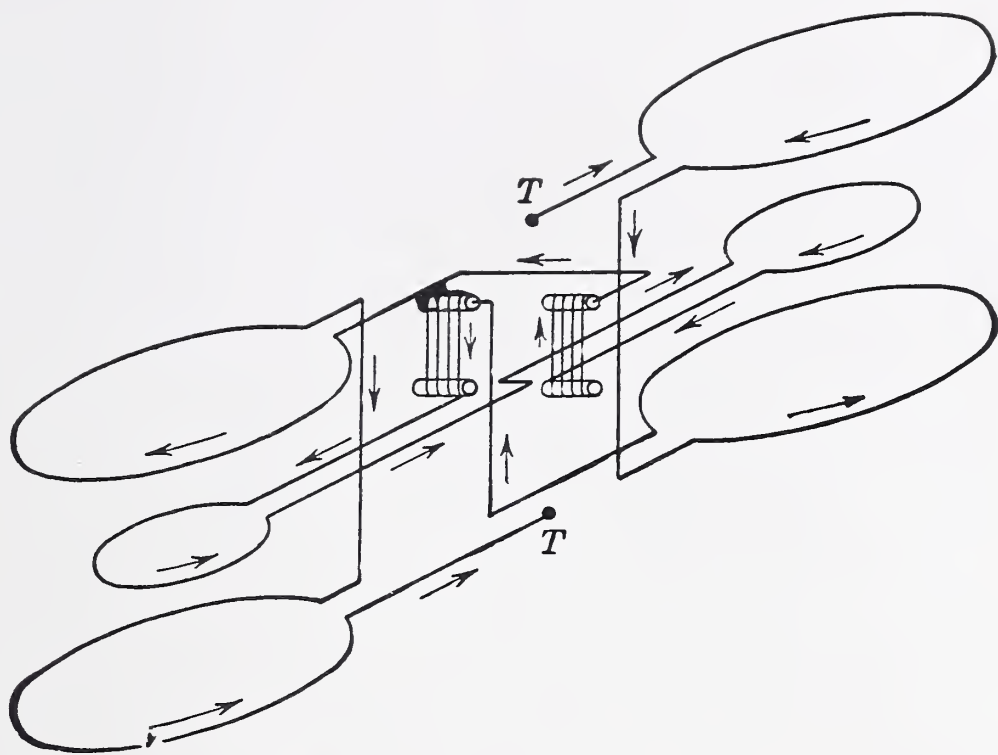

Current Balance, Kelvin (1902) M89

AREA 10 - FLAT CASE

Standard Reference Materials (SRM's)



Standards Eastern Automatic Computer (SEAC)

STANDARD REFERENCE MATERIALS

Standard Reference Materials (SRM's) are well-characterized materials disseminated by NBS to be used to calibrate and evaluate measuring instruments, methods, and systems or to produce scientific data that can be referred readily to a common base. The materials are certified for chemical composition or for a particular physical or chemical property. They are used on-site in science and industry to calibrate instruments and methods used in production and quality control of raw materials, chemicals, metals, ceramics, fuels, and radioactive nuclides in manufacturing processes and in research. Almost 1000 SRM's are available for sale today. One important application is the development of clinical standards. Several billion laboratory tests are performed each year to assist physicians in making diagnoses. NBS has developed more than 20 SRM's for use by clinical chemists to help assure the accuracy of these tests. Another important class of SRM's apply to environmental standards. More than 40 SRM's are now available which provide a common set of accurate standards on which manufacturers and federal, state, and local agencies can base their measurements of potentially harmful air and water pollutants. Over 30,000 SRM's are sold annually.

The SRM effort, initiated in 1906, made the United States the first country with a program of this kind. The first SRM's were transferred to NBS in 1906 by the American Foundrymen's Association. They were a series of irons of certified chemical composition. Several of the original SRM's may be traced through numerous renewals to SRM's in existence today. The SRM number uniquely identifies a particular material and renewals are identified by the letter suffix. Thus 5L represents the 12th renewal of SRM5, Cast Iron C, first issued as Iron C of the American Foundrymen's Association.

References

Catalog of NBS Standard Reference Materials, Nat. Bur. Stand. (U.S.), Spec. Publ. 260 (June 1975).

NBS Annual Report 1906, p. 14; Annual Report 1907, p. 13. The methods of analyses and range of samples were described in NBS C14 (1909), NBS C25 (1910), NBS C26 (1910) and their successive editions.

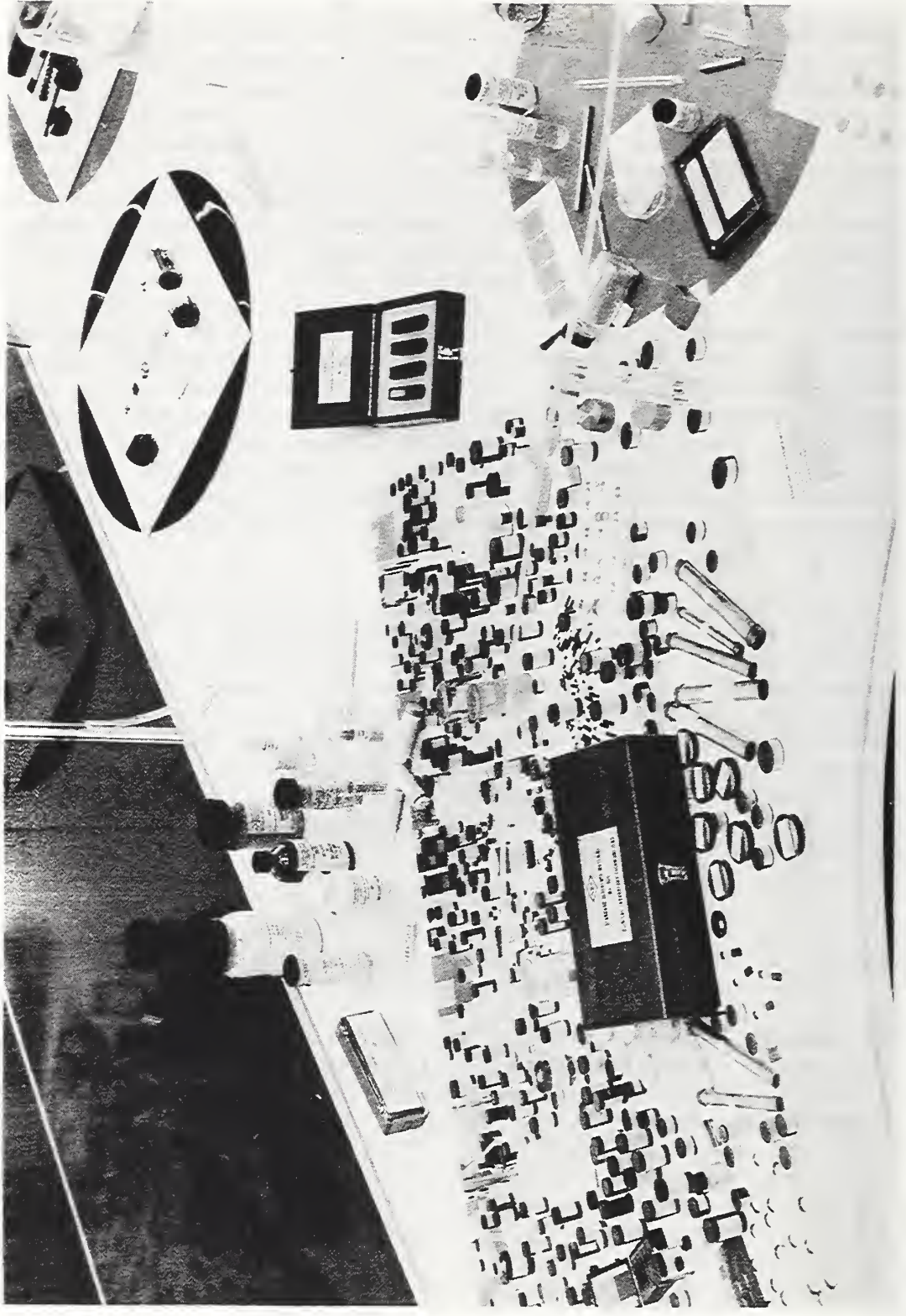

Standard Reference Materials (1906 to Present)

COMPUTER DEVELOPMENT

SEAC (Standards Eastern Automatic Computer)

The design and construction of SEAC was perhaps the major contribution of NBS to the development of computer machinery. Design of this large scale electronic digital computer started in 1948 and construction was completed in May 1950. For the initial two years of its operation, it was the most powerful computer installation readily available to the Government and thus was scheduled for round-the-clock for a full seven day week.

Some of the problems handled by SEAC in its early years were: Solution of partial differential equations by the Monte Carlo method, generation of optimum sampling plans for the Bureau of Census, problems in crystal structure, relative abundance of the elements, wave functions of atoms, lens design, synchrotron design, electric circuit design, transient stresses in aircraft structures, social security accounting procedures, and classified problems for the AEC.

SEAC was a serial computer operating completely in the binary system at a one megacycle rate. It included many innovative ideas, such as the use of 16000 germanium diodes to carry out all logic functions and ac coupling using pulse transformers for highly variable duty factor service. Vacuum tubes were used for power amplification only, rather than as grating devices. The original high speed memory on SEAC was 512 words of 45 binary bits each, which later expanded to 1024 words. The original SEAC is now in the custody of the Smithsonian Institution.

REPRESENTATIVE SEAC COMPONENTS

M538

CRYSTAL CLUSTER AND CURRENT

SEAC was probably the first large scale computer to make extensive use of diode grating. This is the method by which the logic functions of the machine were carried out. The display shows the construction technique. There were perhaps 20 or so versions of this type of cluster.

MERCURY DELAY LINE

Early form of mercury delay line used for memory in SEAC development. Heavy aluminum extruded form was used to retain heat.

ACOUSTIC MEMORY AMPLIFIERS AND GATING CIRCUITS FOR SEAC

This device amplified the small signals coming out of the mercury delay lines. It also permitted the "writing" of new information in the lines. Each line was capable of storing 384 binary bits.

References

Computer Development (SEAC and DYSEAC) at the National Bureau of Standards, Nat. Bur. Stand. (U.S.), Circ. 551 (Jan. 25, 1955).

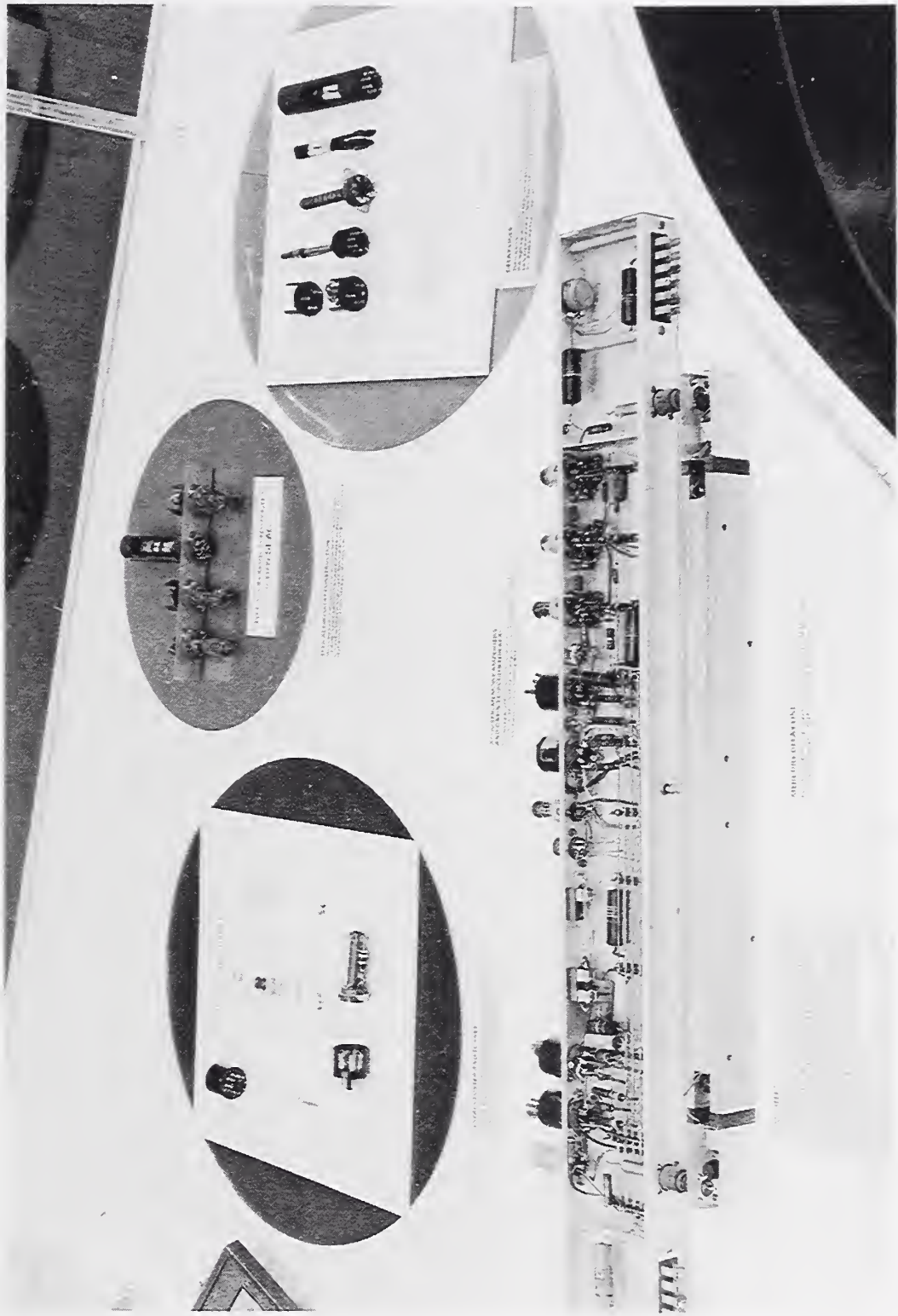

Standards Eastern Automatic Computer (SEAC) Representative components M538

AREA 11 Time 

The mechanical clock designed by W. H. Shortt of the Edinburgh Observatory has two pendulums with one-second periods. The master pendulum swings essentially free in the evacuated chamber on the left. Every 30 seconds, at the instant when the pendulum has reached the left extreme of its swing and begun the return to its position, a small lever descends under the action of gravity and gives the pendulum a gentle impulse. Thus there is negligible interference with the uniformity of its oscillation.

The lever is tripped by a circuit closed by a slave pendulum in the cabinet below the clock faces. It oscillates at a rate a little slower than the free pendulum, but is periodically speeded up to within ± 0.003 seconds of the master by the action of a "hit-and-miss" synchronizer. The synchronizer consists of a very light spring which is attached to the rod of the slave pendulum and which is flexed by striking an electromagnet-positioned stop.

This clock was purchased in 1929 from the Synchronome Co. of London. Having a precision within about 1 ms per day, it quickly supplanted the Riefler Clock (M515) in astronomical observatories, but was in turn replaced within a few years by quartz crystal oscillators similar to M373.

References

- Rawlings, A. L., figure 44, p. 123 in *Science of Clocks and Watches*, 2d edition (Pitman Sons, 1948).
- Hope-Jones, F., Chapter XVII in *Electrical Timekeeping*, 2d edition (N.A.G. Press, 1949).

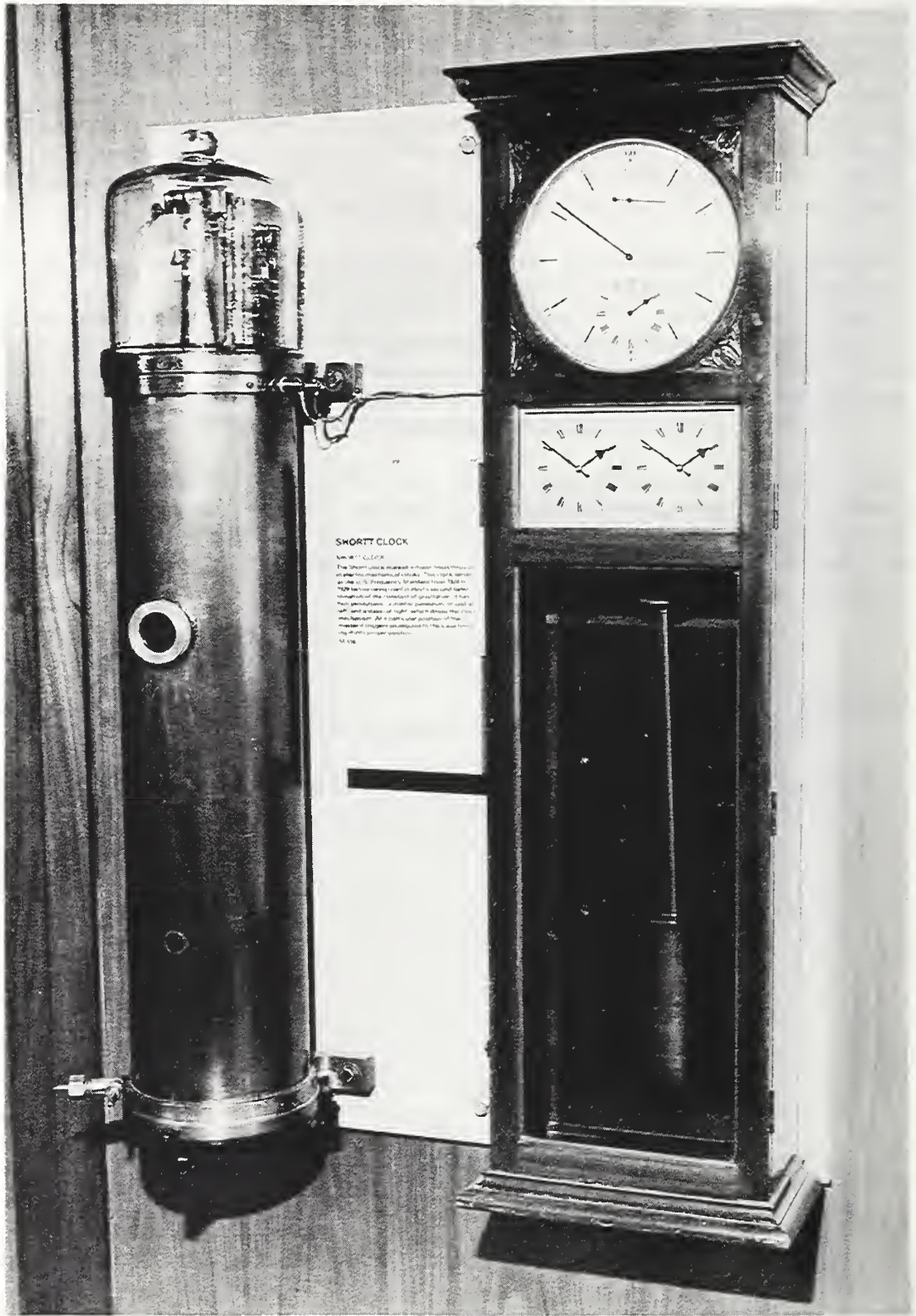

SHORTT CLOCK

QUARTZ CLOCK

The Shortt clock is superior to other quartz clocks in an important characteristic. This quartz resonator has a frequency of 327,662 Hz. This is the same as the frequency of the quartz crystal used in the Shortt clock. A quartz resonator is used in the Shortt clock as a frequency standard. The quartz resonator is a quartz crystal which vibrates at a constant rate when subjected to a certain voltage. The frequency of vibration is determined by the size and shape of the quartz crystal.

Shortt Clock (1921) M516

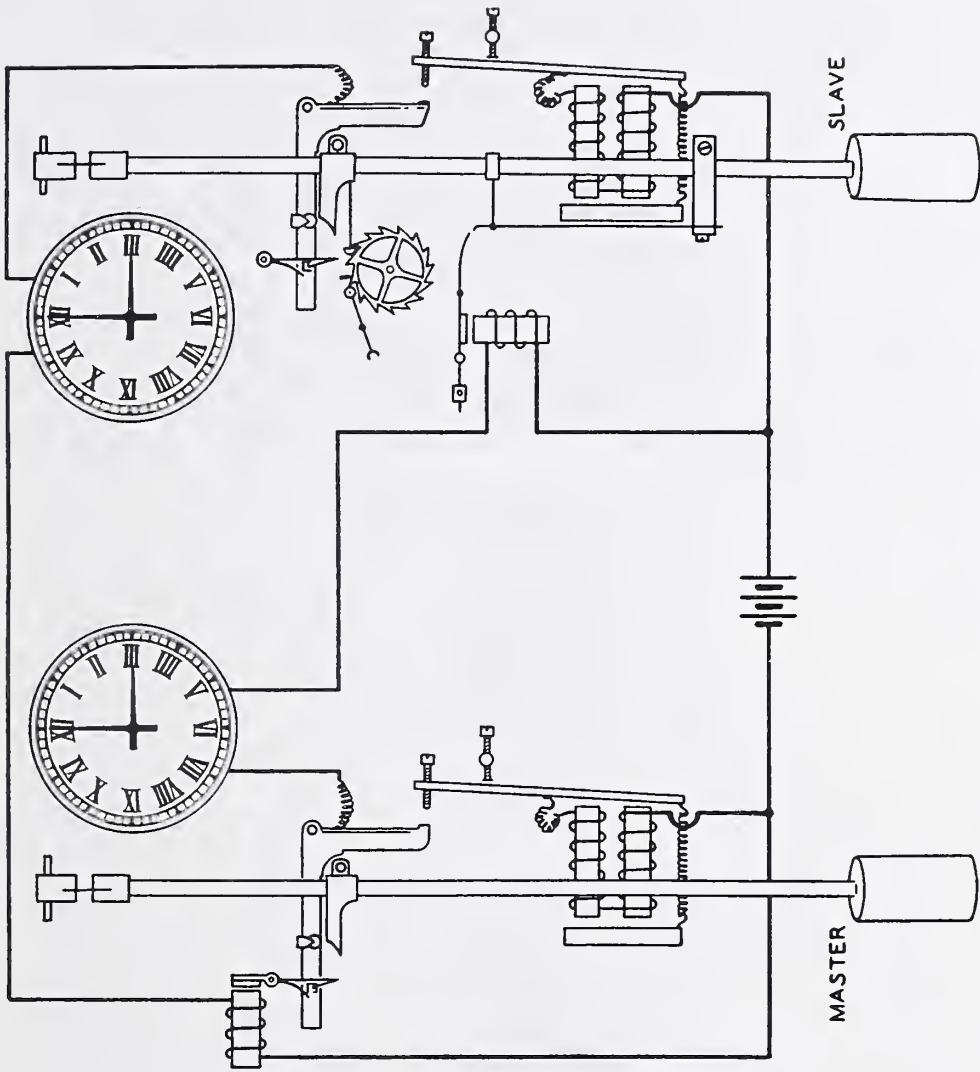

Shortt Clock (1921) M516
 Schematic drawing of mechanism and circuit

In a mechanical clock, the essential action in maintaining a uniform time interval is the regular oscillation of a pendulum of fixed length. For greatest precision, this oscillation must be free from the drag of the escapement and gear train which is used to drive the hands of the clock.

Dr. Siegmund Riefler of Munich devised a means by which regular impulses are imparted to the pendulum by means of the short leaf spring by which it is suspended. This spring is flexed each second when its upper end is rocked through a small angle by the motion of the escapement wheel. The escapement arbor is driven by the torque exerted by a small weight (hidden behind the clock face in M515) which falls a distance of about one centimeter every 30 seconds. At the bottom of its fall it closes a circuit which actuates a battery-energized electromagnet (visible at the right) which lifts it up again.

This clock was purchased from Clemens Riefler in 1904 and served for precise time interval measurement (to within about 10 ms per day) through NBS until 1929, when it was replaced by the Shortt Clock (M516). Its pendulum mass, carried by a long rod of nickel steel nearly insensitive to temperature changes, swings in a partially evacuated chamber.

References

Haswell, J. E., *Horology*, p. 30 (Chapman & Hall, 1928).

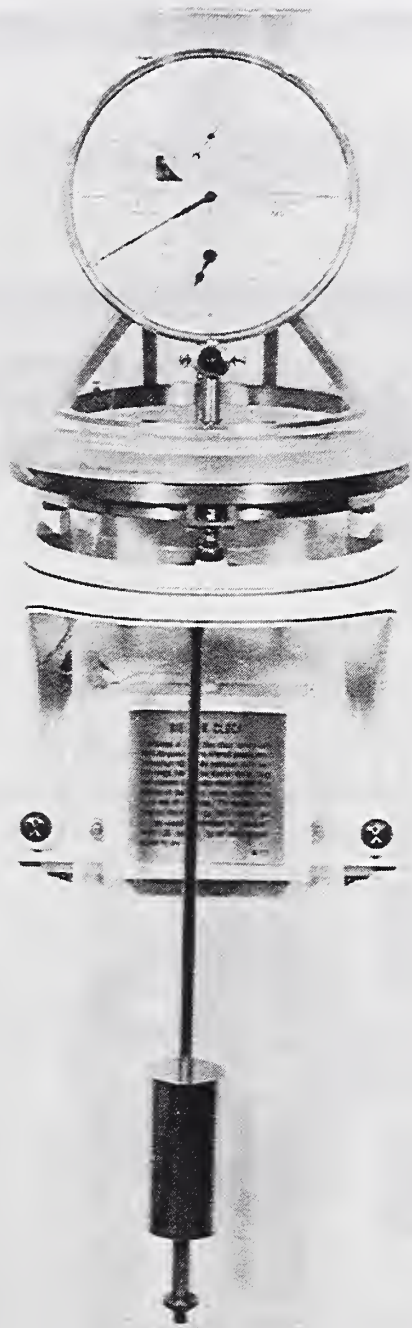

Clock, Riefler (1891) M515

AREA 12

Electrical Resistance



This computable standard mutual inductor was the principal element in the absolute measurement of resistance by the Wenner method. That operation, together with measurements by a second method at NBS, and another method at the National Physical Laboratory in England, was the basis on which the International Committee on Weights and Measures assigned the value: 1 mean international ohm (1947) = 1.000484 absolute ohms (1948).

The primary is wound on a porcelain cylinder 41 cm in diameter and 83 cm in length, lapped with grooves of 2 mm pitch by the techniques of C. Moon. The two gaps in the winding are Dr. Wenner's improvement of A. Campbell's design. They provide a larger volume in the central plane in which the magnetic field is very small and in which the positioning of the secondary coil, of 218 turns in 24 layers, is not so critical to the measurement. The mutual inductance at 23 °C was 10.897220 millihenrys.

The other elements in the Wenner method include an electronically synchronized reversal of the primary current and of the associated switching operations, using a flat-topped waveform.

References

Thomas, J. L., Peterson, C., Cooter, I. L., and Kotter, F. R., An absolute measurement of resistance by the Wenner method, Nat. Bur. Stand. (U.S.), J. Res. 43, 291, RP2029 (1949).

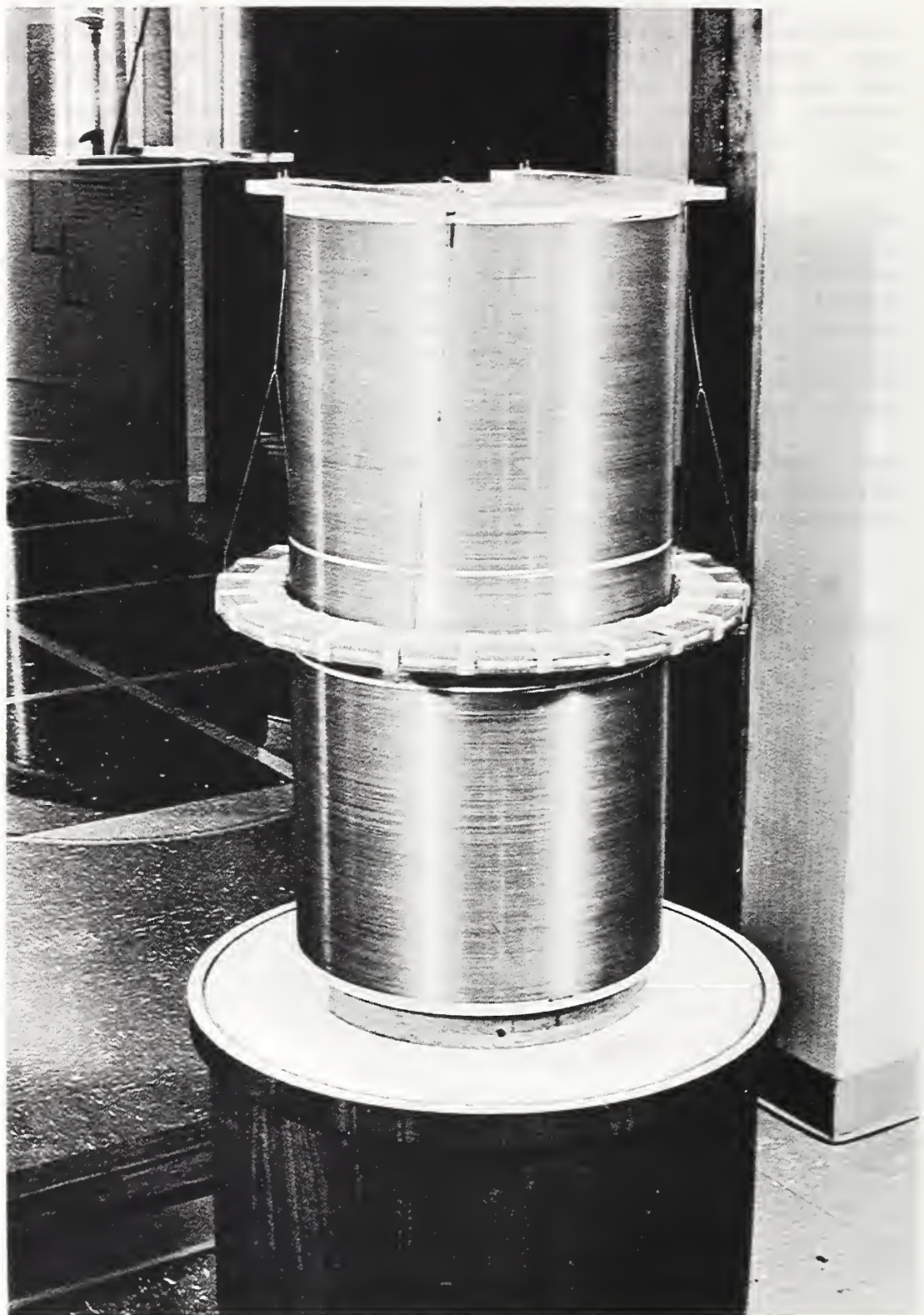

Mutual Inductor, Wenner (1938) M41

AREA 13 - DRUM CASE II

Pressure



PRESSURE

The need for more accurate pressure measurements has been constant throughout NBS history. From the first working standard, obtained in 1904 for calibrating aneroid barometers, to present requirements for high pressure standards in the 100,000-atmosphere range or the extremely low pressure measurements needed in space research, the advance of science and technology in this country has been aided by the Bureau's ability to meet these needs.

This design was developed as a laboratory standard to calibrate portable mercury barometers and aneroid barometers. Vacuum was maintained in the right-hand leg of the 20 mm bore U-tube by the diffusion pump at the rear. Cold traps (chilled by liquid air dewars) kept oil vapor away from the mercury. The McLeod gage on the right was used to measure the vacuum. The left-hand leg of the U-tube was connected to the test instrument through a glass wool filter, and the test pressure was maintained constant by a novel pneumatic barostat while the observations were being made. Protection against overpressure was provided by the 5 mm mercury column and cistern on the left. Both legs of the U-tube were striped with copper paint to reduce the contamination of the mercury, apparently caused by the contact potential difference between mercury and glass.

The difference in mercury levels in the two legs was read by telescopes equipped with vernier reticules, and mounted so as to view alternately the menisci and the adjoining graduated scale. Mercury surfaces were illuminated from behind by flashlight bulbs in carriages movable by a small electric motor. In the basement laboratory where the barometer was mounted on a cork-and-concrete foundation, the temperature was held to 25 ± 0.1 °C. The precision of pressure measurement was within ± 0.02 mm mercury, with systematic errors estimated at about the same value.

The instrument was used during the war years (1941-45) to calibrate hundreds of barometers for the U.S. Air Force. In later years it was used mainly to calibrate barometers of the U.S. Weather Bureau and the International Meteorological Society, and for aneroids of the Federation Aeronautique Internationale. Pressure altitude recording instruments for the USAF 1957 stratosphere flight to a record 100,000 ft were checked against this mercury barometer. By 1960 several manufacturers were producing portable instruments which they calibrated with primary standards of mass, length, time, and temperature, to show accuracies approximately equal to those of this instrument similarly calibrated. Consequently it was retired about 1963. The NBS standard is now the low pressure manometer used for ultra-precise work in gas thermometry.

References

Brombacher, W. G., Johnson, D. P., and Cross, J. L., Mercury Barometers and Manometers, Nat. Bur. Stand. (U.S.), Monogr. 8 (May 1960).

Nat. Bur. Stand. (U.S.), Tech. News Bull. 55, 73 (Mar. 1971).

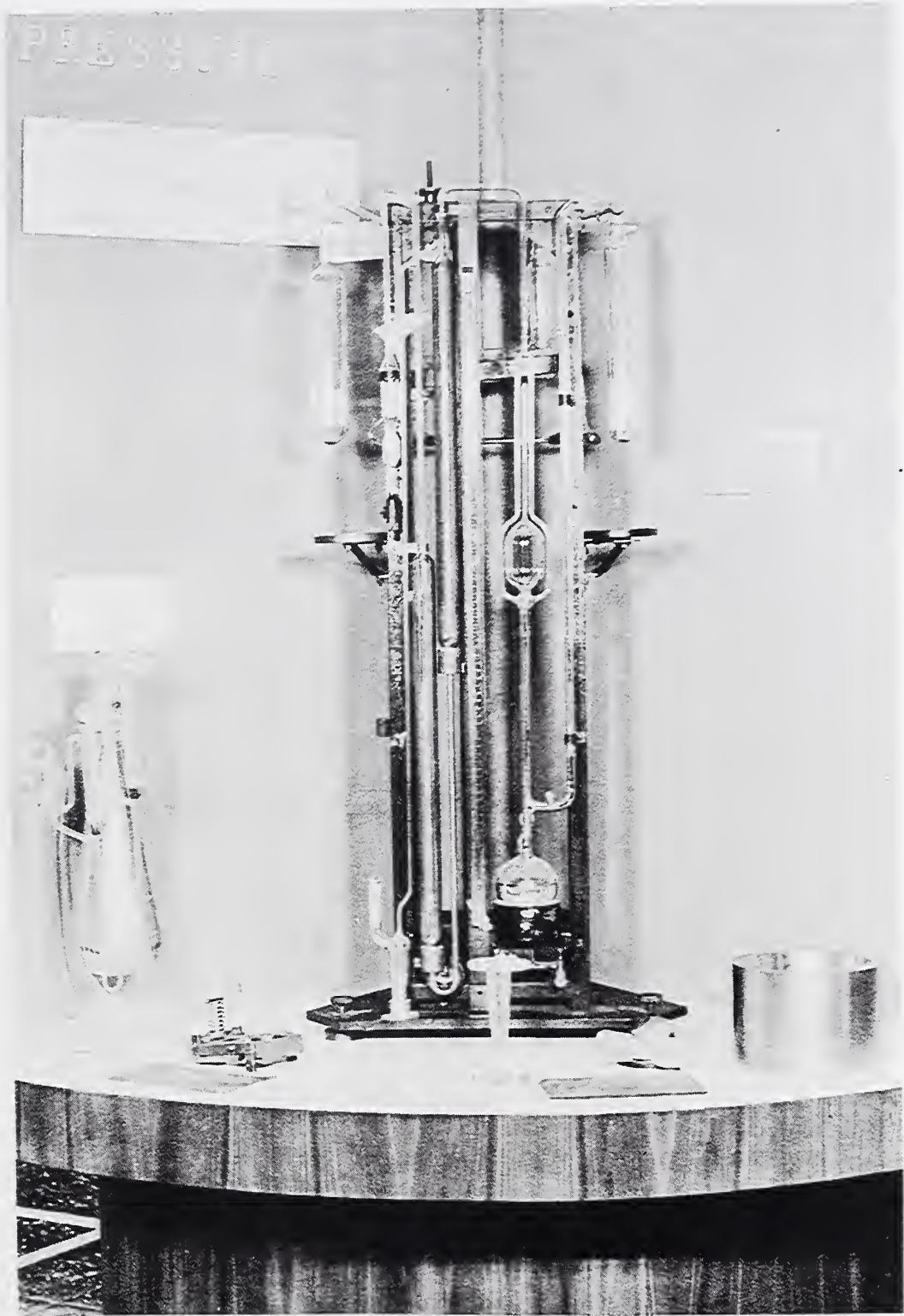

U-Tube Barometer (1941) M462

The single-stage mercury vapor pump developed by Langmuir in 1916 was not only simple, but provided a higher vacuum and a larger exhaustion rate than pumps previously existing. At NBS, H. F. Stimson modified the design by using two stages to permit the use of a simple water aspirator as a fore-pump.

A stream of mercury vapor generated in the jacketed glass boiler at the rear is fed to both stages at a temperature of about 290 °C. Both stages are water-jacketed to cool the mercury, which is returned to the boiler as a liquid. In the first stage on the right is a diverging nozzle 4 cm long in the top of the Pyrex glass envelope. The nozzle produces a high velocity jet of mercury vapor which entrains gas from the vessel to be evacuated, and sweeps it, at increased pressure, to the second stage.

At the second stage, a short nozzle produces a further pressure increase of the entrained gas. From the bottom of the second stage the gas flows to a fore-pump from a connection on the left. Its absolute pressure (about 2 cm Hg) is indicated by a small mercury manometer, on the bottom left.

References

Stimson, H. F., A two-stage mercury vapor pump, J. Wash. Acad. Sci. VII, No. 15, 477 (1917).

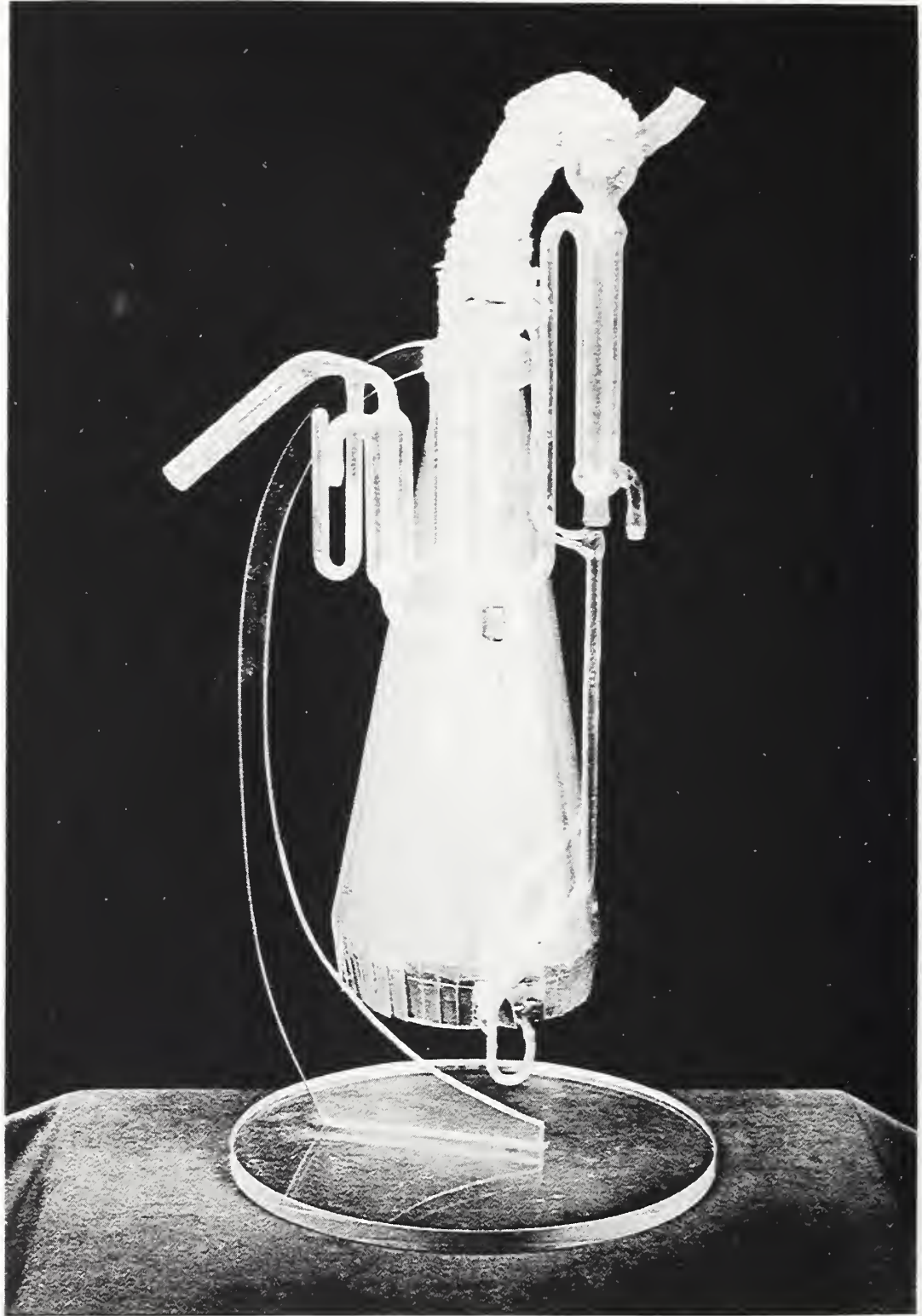

Vacuum Pump, Two-Stage (1917) M414

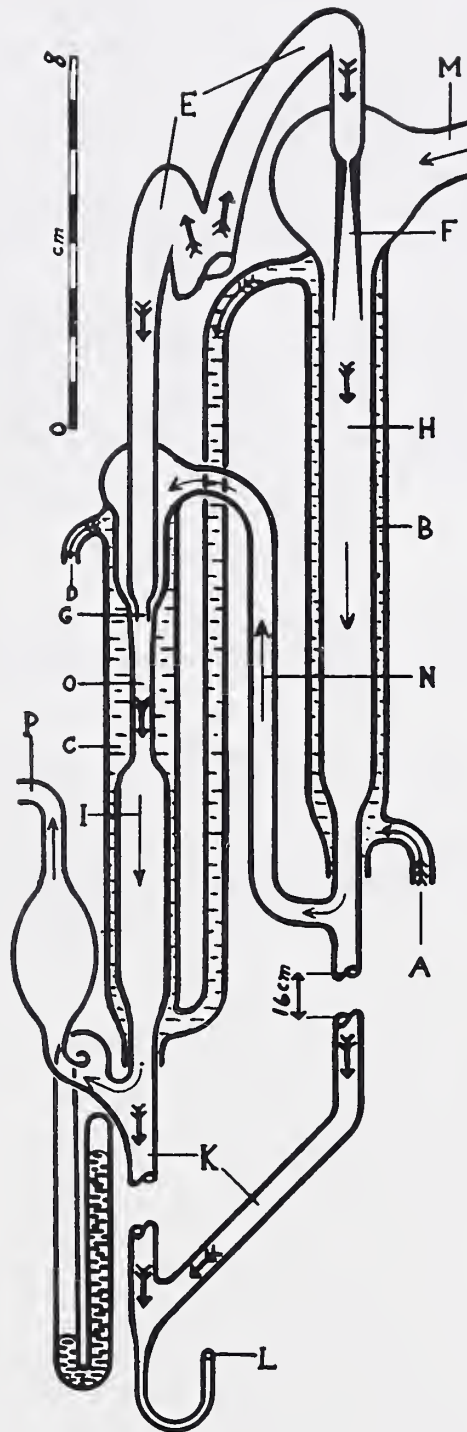

Vacuum Pump, Two-Stage (1917) M414
Schematic drawing

In order to study the effects of very high pressure on molecular interactions, finely powdered material is squeezed to a film between the flat surfaces of two gem-cut diamonds. The facets which form the anvil have an area of about 0.1 mm^2 (0.0002 in^2) and the diamonds are of Type II which is transparent to infrared radiation between 1750 cm^{-1} and 300 cm^{-1} . Each diamond is mounted in a close-fitting recess in a piston of 1 cm diameter and having an axial hole which permits passage of the radiation beam. The anvil faces can be adjusted to parallelism by means of a set of tiny leveling screws.

The entire assembly is sufficiently compact to be held on the stage of a microscope or placed in an infrared spectrometer or an x-ray diffractometer. Anvil pressures up to 20 gigapascals (200 kilobars) can be developed, the force being applied to the anvil facets through the mounting pistons by compression of the helical spring acting through the 2:1 lever system.

References

- Weir, C. E., et al., Infrared studies in the 1-to-15 micron region to 30,000 atmospheres, Nat. Bur. Stand. (U.S.), J. Res. 63A, 55 (1959).
- Weir, C. E., et al., High-Pressure Optical Cell, U.S. Patent 3,079,505 (Feb. 26, 1963).
- Piermarini, G. J. and Weir, C. E., A diamond cell for x-ray diffraction studies at high pressures, Nat. Bur. Stand. (U.S.), J. Res. 66A, 325 (1962).

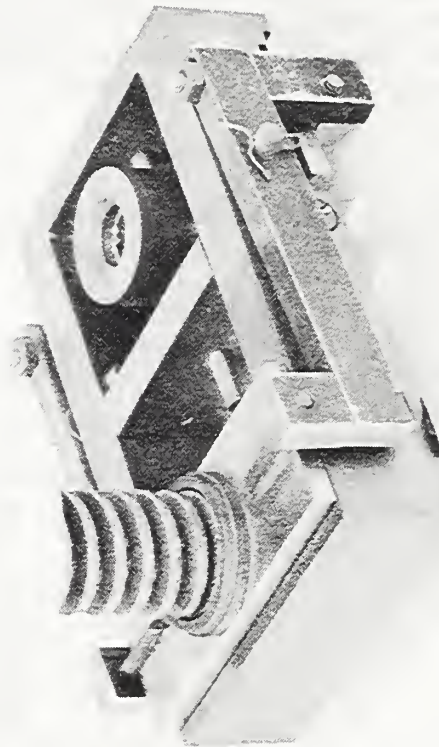

Diamond Anvil Optical Cell (1958) M325

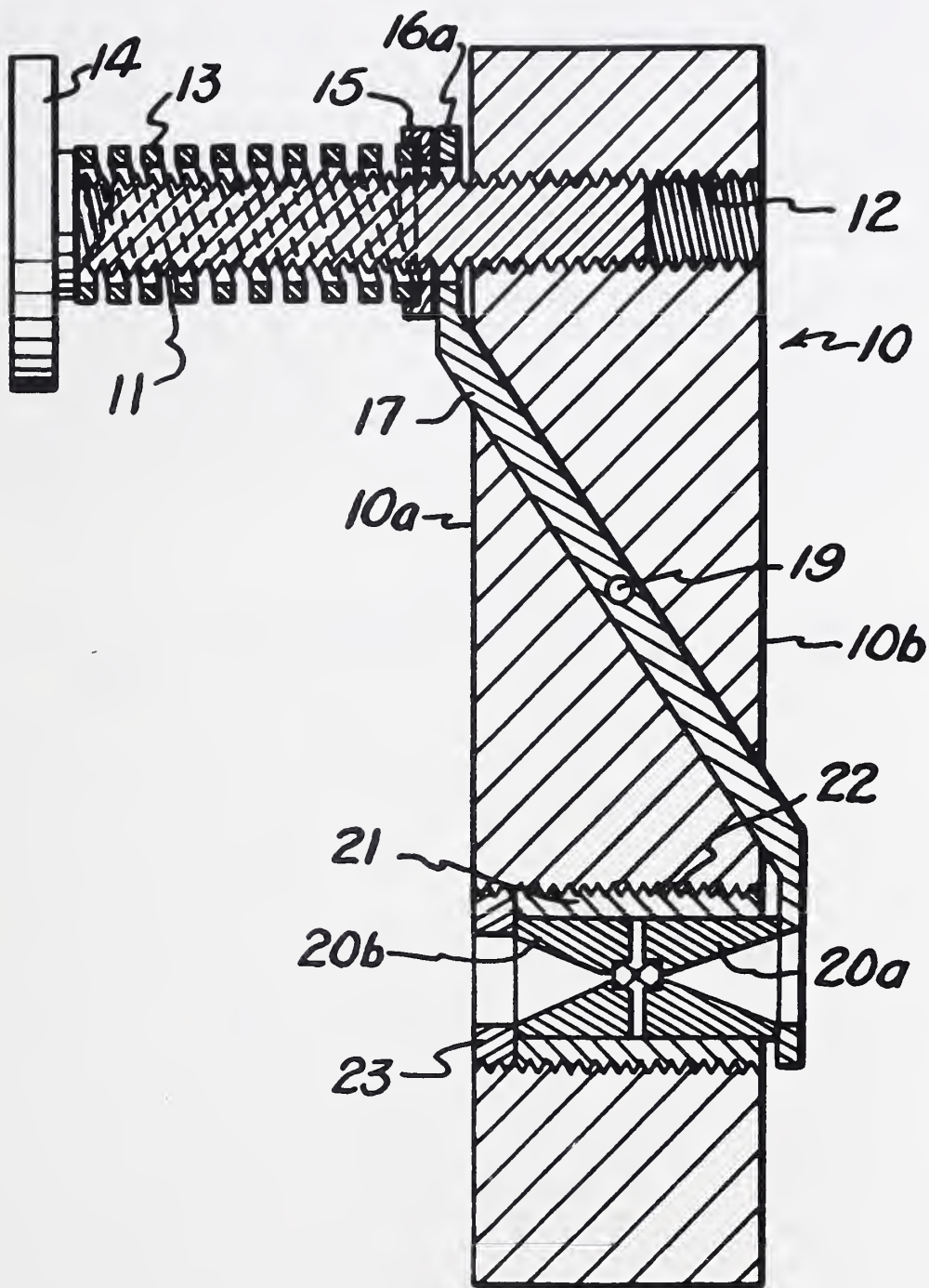

Diamond Anvil Optical Cell (1958) M325
 Patent drawing of high-pressure optical cell

In order to study the properties of bulk material at pressures on the order of 10 gigapascals (100,000 atmospheres) this wedge-type tetrahedral anvil device was developed at NBS as a modification of the multiple hydraulic rams used by H. T. Hall in 1958. The specimen is inserted in a drilled hole in a 1.5-cm regular tetrahedron of pyrophyllite, a soft mineral which serves as gasketing material. Strips of silver foil at either end of the test specimen provide electrical connections for measurement of the polymorphic transition pressures evidenced by resistance change.

The three lower faces of the tetrahedron are supported by three tungsten carbide anvils, shown here with the top anvil and its supporting block removed and inverted. The three lower anvils and their supporting blocks are held in a conical carrier, of 18-1/2 degrees half-angle. Sheets of Teflon separate the carrier from its retaining ring, and the lower anvils are wedged toward one another when a force (up to 50 ton) is applied to the top anvil and holder.

References

Lloyd, E. C., et al., Compact multi-anvil wedge-type high pressure apparatus, Nat. Bur. Stand. (U.S.), J. Res. 63C, No. 1, 59 (1959).

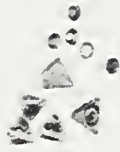
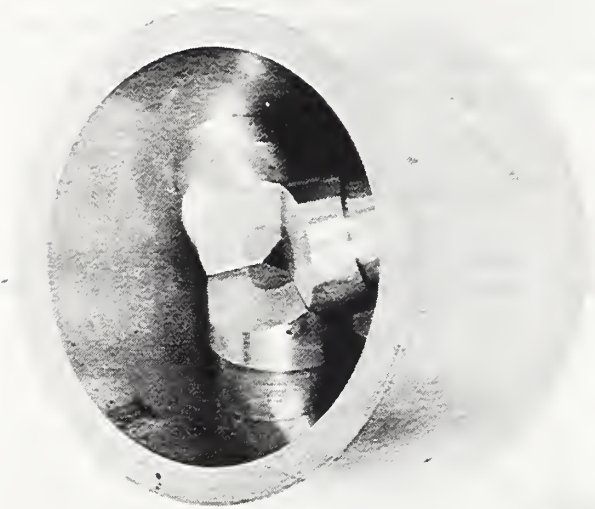

Tetrahedral Anvil Pressure Apparatus (1959) M38

AREA 14 - DRUM CASE II

Optics



OPTICS

Since its establishment, NBS has pioneered in optics research and measurement. The Bureau's establishment of standards and its development of measurement methods and instrumentation has contributed materially to the tremendous scientific advances in such fields as spectroscopy, polarimetry, refractometry, glass technology, microscopy, photometry, colorimetry and interferometry.

To lessen independence on foreign suppliers of optical glass, NBS undertook study of its manufacture in 1914. Good quality prisms and lenses require precise measurement of refractive index, and this spectrometer was probably the best instrument commercially available at the time. A light source is set up on the left, in front of the adjustable width slit attached to the collimator tube, which directed a beam of parallel rays onto the specimen set on the central table. The long telescope on the right is mounted on a rotatable frame so that it can be aligned with the emergent beam. The frame carries five short micrometer microscopes, which look through tiny windows at the graduations on a stationary circle 308 mm in diameter (not visible). By taking measurements of the angle between collimator and telescope at several positions around the circle, accuracy of less than one second is obtainable.

This instrument was used during World War II to supply data to firms making optical glass, and during World War II to examine all optical glass produced at NBS, as well as to study the effect of various annealing procedures. In the 1930's it served for a classic study of the refractive index of distilled water, and in the 1950's for similar measurements on other substances needed as standards for the calibration of spectrometers. Since 1952 smaller and more convenient devices have become available.

References

- Cochrane, R. C., Measures for Progress, Nat. Bur. Stand. (U.S.), Misc. Publ. 275, 186 (1966).
- Tool, A. Q., Tilton, L. W., and Saunders, J. B., Changes caused in the refractivity and density of glass by annealing, Nat. Bur. Stand. (U.S.), J. Res. 38, 519, RP1793 (1947).
- Tilton, L. W. and Taylor, J. K., Refractive index and dispersion of distilled water for visible radiation, Nat. Bur. Stand. (U.S.), J. Res. 20, 419, RP1085 (1938).
- Stephens, R. E. and Malitson, I. H., Index of refraction of magnesium oxide, Nat. Bur. Stand. (U.S.), J. Res. 49, 249, RP2360 (1952).

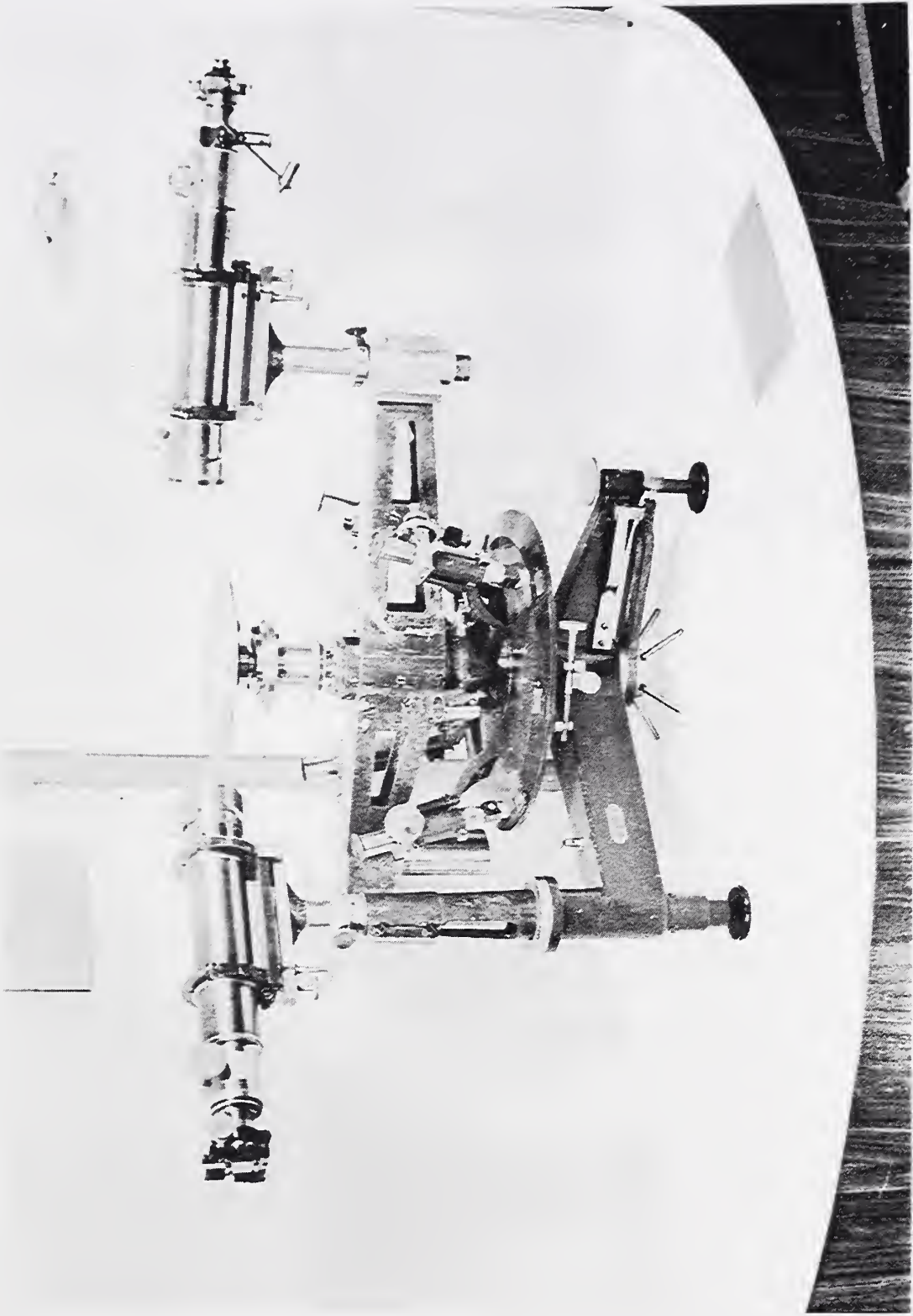

Spectrometer, Societe Genevoise (1912) M14

This is one of the first instruments built in the NBS shops, and was designed by Director Stratton. The heavy steel bed carries a precision screw of 0.5 mm pitch which adjusts the position of a steel carriage carrying a circular frame. In the frame was mounted a fully silvered glass mirror adjusted to an angle of about 14 min with the optical axis. The brass block at the left held a second partially silvered mirror which split the reflected beam. The worm and wheel on the end, readable to 0.01 mm, drove the precision screw, and the incremental difference of carriage positions, giving rise to interference patterns, was read from a scale and microscope not shown.

Work by I. G. Priest determined the bright yellow neon line as $\lambda_{\text{a}}=5852.4862$ international angstroms referenced to the cadmium red standard, with an average probable error in 6 determinations of about one part in 9,000,000.

References

Priest, I. G., A modified method for the determination of relative wave-lengths, Bull. Nat. Bur. Stand. 6, 573 (1909-10).

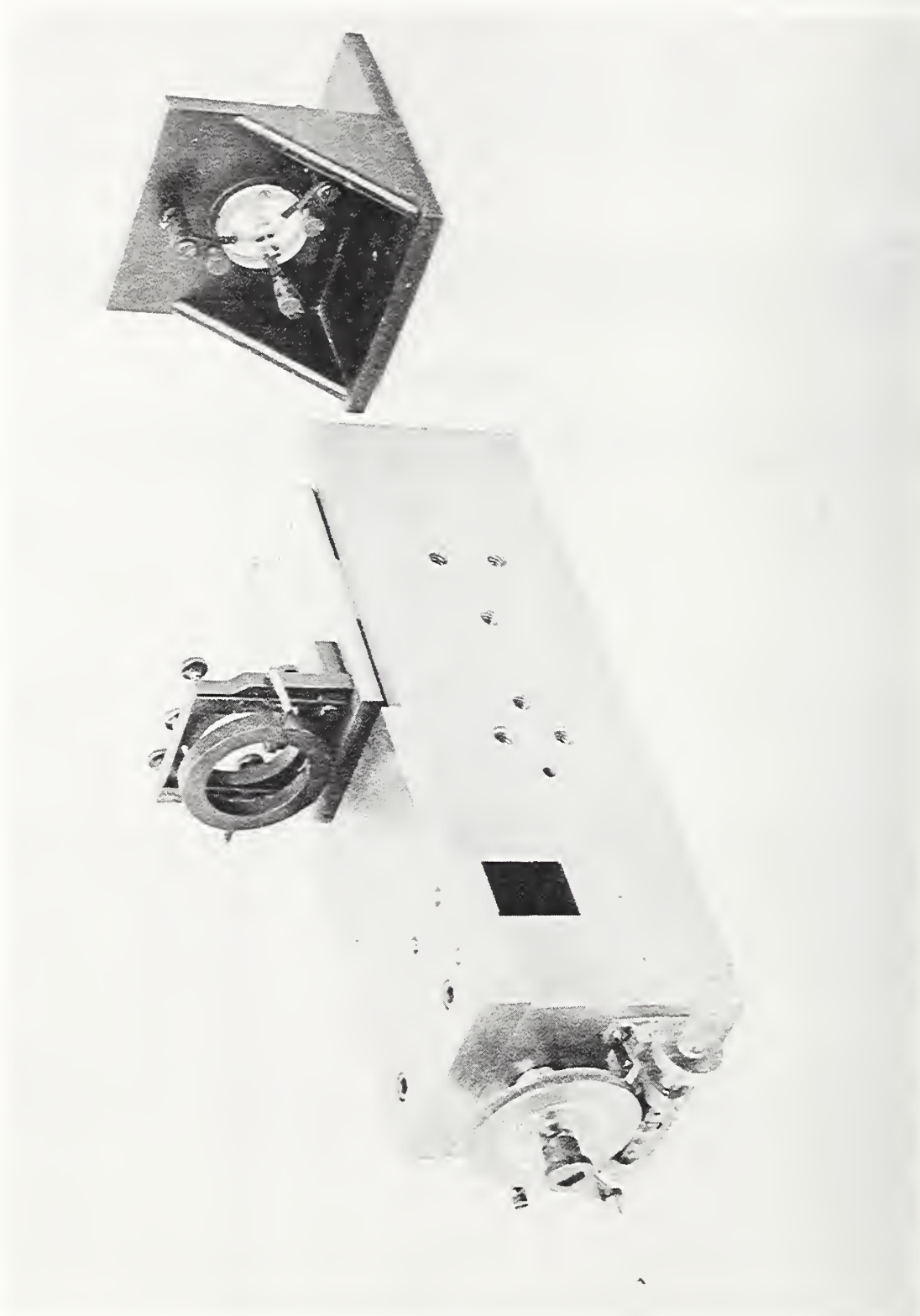

Interferometer, Fabry-Perot. (1967) N275

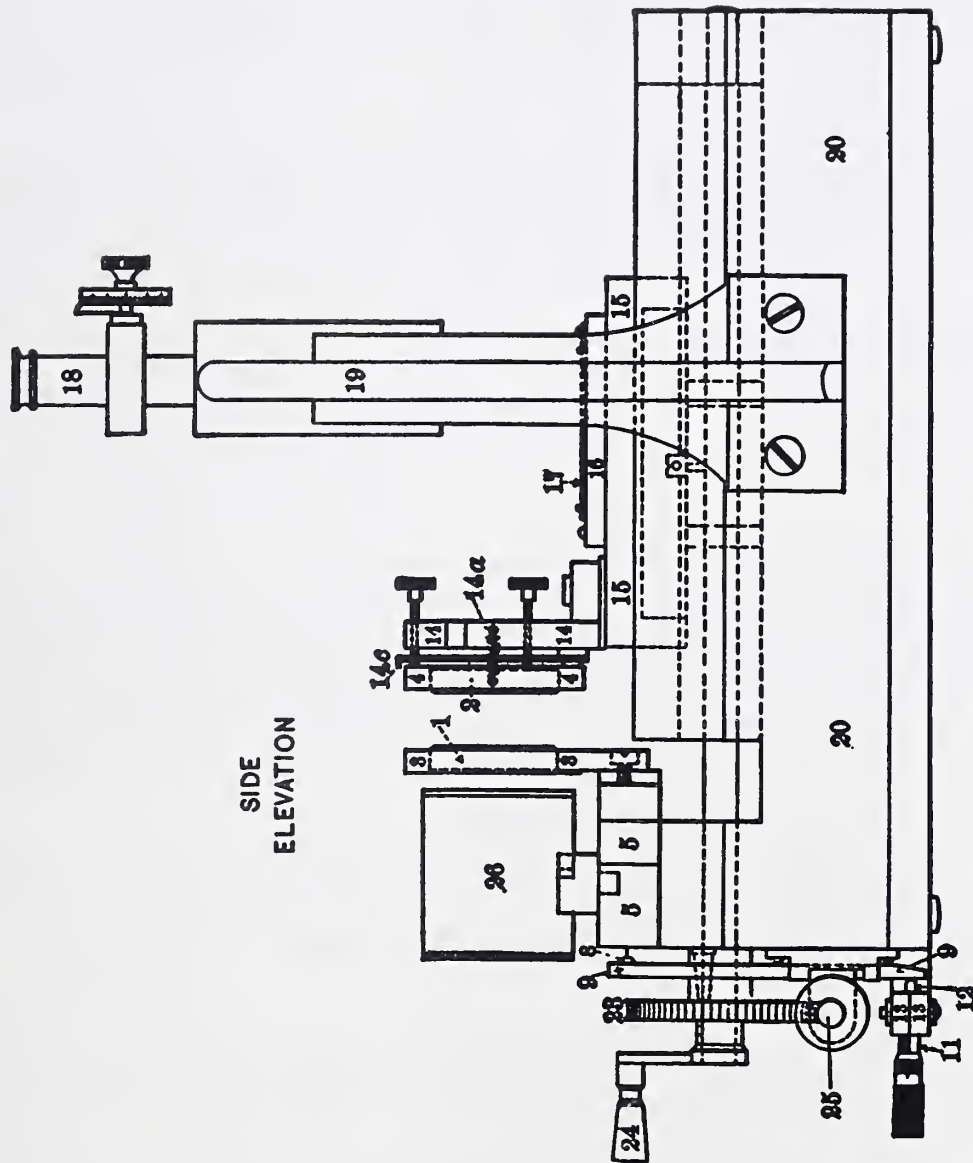

SIDE
ELEVATION

Interferometer, Fabry-Perot (1907) M275
Schematic drawing

Many chemical elements of the solar system can be identified by the bright lines observed at specific wavelengths in the spectra created by diffracting the light they radiate. As early as 1889, A. A. Michelson and E. W. Morley suggested the feasibility of establishing such a wavelength as the ultimate standard to replace the meter bar. In 1894 Michelson carried out the comparison with the standard meter, using the red, green, and blue lines of cadmium. Lamp M400, made by F. O. Westfall about 1947, also uses cadmium.

In 1889 Fabry and Perot used a parallel-plate interferometer in further development of an international system of wavelength normals. Their method was modified in 1910 by I. G. Priest at NBS, who introduced reflection fringes and subsequently measured 10 wavelengths in the neon spectrum, using lamp M398.

In 1942, W. F. Meggers of NBS developed an electrodeless lamp using the isotope mercury-198 suggested earlier by Prof. Louis Alvarez. Subsequent models, like lamp M274, were made with this isotope as produced by neutron bombardment of gold. The 5461-angstrom line is very brilliant, and when the lamp is excited by 200 megahertz, its life is indefinitely long.

The red line of cadmium was the wavelength standard adopted by the International Astronomical Union in 1938, and the orange-red line of krypton-86 was adopted as a length standard by the International Committee on Weights and Measures in 1960. However, the simplicity of operation of the mercury-198 lamp for laboratory length measurements causes it to be used more frequently than any other source.

References

Baly, E. C. C., Spectroscopy (Longmans, London, 1905).

Priest, I. G., Wavelengths of Neon, Bull. Nat. Bur. Stand. 8, 539 (1912).

Meggers, W. F. and Westfall, F. O., Lamps and wavelengths of mercury 198, Nat. Bur. Stand. (U.S.), J. Res. 44, 447 (1950).

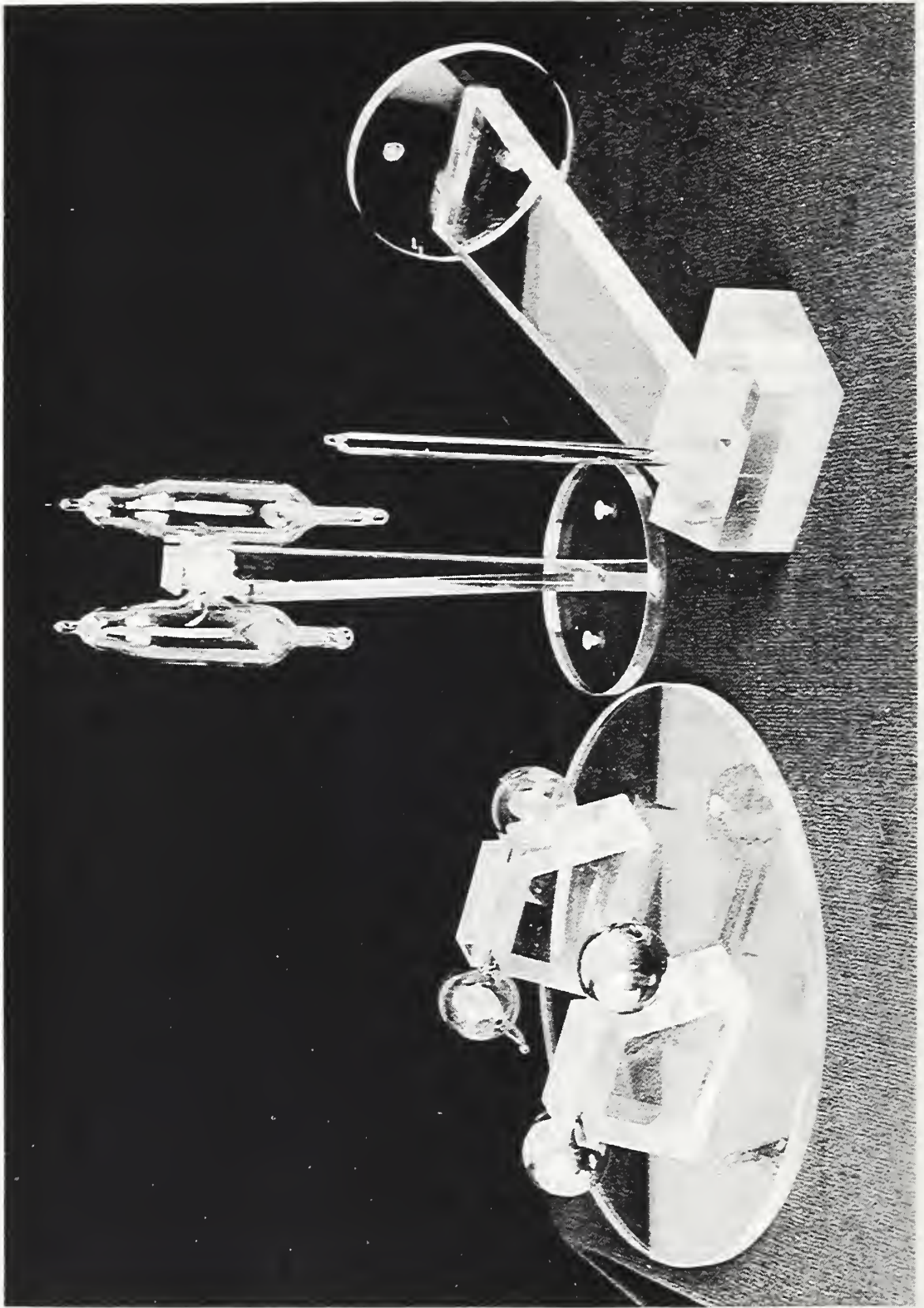

Wavelength Standards (1889 - 1960) M274, N400, M398

AREA 15 - DRUM CASE II

Electricity



ELECTRICITY

Charged with the duty to establish, maintain, and disseminate the electrical standards of measure, NBS has held a position of research leadership throughout its history in the development of standards, methods of measurement, and instrumentation. These developments serve all of science and technology within the framework of a national measuring system that applies equally to the electricity meters in 80 million homes and to the complex guidance and control systems of space vehicles.

The ratio of the electrostatic to the electromagnetic units of electricity is important to electrical theory, and its square root is also the speed of light. E. B. Rosa had measured the ratio at Johns Hopkins in 1889, using a spherical capacitor. By 1904, he felt that superior facilities at NBS warranted a redetermination, using a cylindrical and a parallel plate capacitor as well as the spherical one which was borrowed from the university.

The cylindrical capacitor (M30) consists of four silver-plated brass sections 12, 20, 20 and 12 cm long, the lowest and uppermost sections serving as guards for the study of end effects. Each section consists of an outer cylinder of 7.241 cm radius and an inner cylinder of 6.257 cm radius. (In the display the upper 20 cm outer cylinder has been removed and set to one side.) At the top of the upper guard section is a knurled knob attached to a screw of 0.5 mm pitch, by which the axial clearance between inner cylinder and its guard can be adjusted over a 10 mm range.

In the parallel plate capacitor (M47) the insulated collector plate is not visible. Below the supporting top plate 6 mm thick and 30 cm in diameter may be seen a silver-plated guard ring which surrounds the collector plate. Electrical screening of the latter is completed by the top plate and by a short cylinder fastened to the guard ring and reaching nearly to the top plate. The lower capacitor plate of 20 cm diameter is supported on 3 leveling screws carried by a threaded rod of 1.5 cm diameter which moves axially between rigid posts, and has at its lower end a screw of 0.5 mm pitch. Adjustment of the dielectric space between capacitor plates is made over a range 1 to 30 mm with the micrometer dial below, and may be read by a micrometer microscope rigidly attached to the base.

Measurement of the capacitance of a condenser in electrostatic units depends on the dielectric (in this case air) and the dimensions of the dielectric space, with due regard for fringe effects.

Two methods were used by Rosa and Dorsey to measure the capacitance in electromagnetic units. The first, recommended by Maxwell, consists of replacing one of the resistances in a Wheatstone bridge by a condenser and a suitable commutator for rapidly and regularly charging and discharging the condenser. By adjustment of the frequency of the charging, and of the resistances of the net, a balance of the galvanometer can be obtained. In the second method, the charging or the discharging current is passed through one coil of a differential galvanometer, while through the other coil is passed a steady current. The latter is shunted off from part of a high resistance circuit which permanently connects the terminals of the battery employed to charge the condenser.

In this classic work extending over a period of two years, numerous possible sources of error were examined and corrections were made for them. The mean value found for square root of the ratio for an air capacitor was 2.9963×10^{10} with an uncertainty of not more than 1 in 10,000.

References

Rosa, E. B. and Dorsey, N. E., A New Determination of the Ratio of the Electromagnetic to the Electrostatic Unit of Electricity, Bull. Nat. Bur. Stand. 3, 433, 541 (1907).

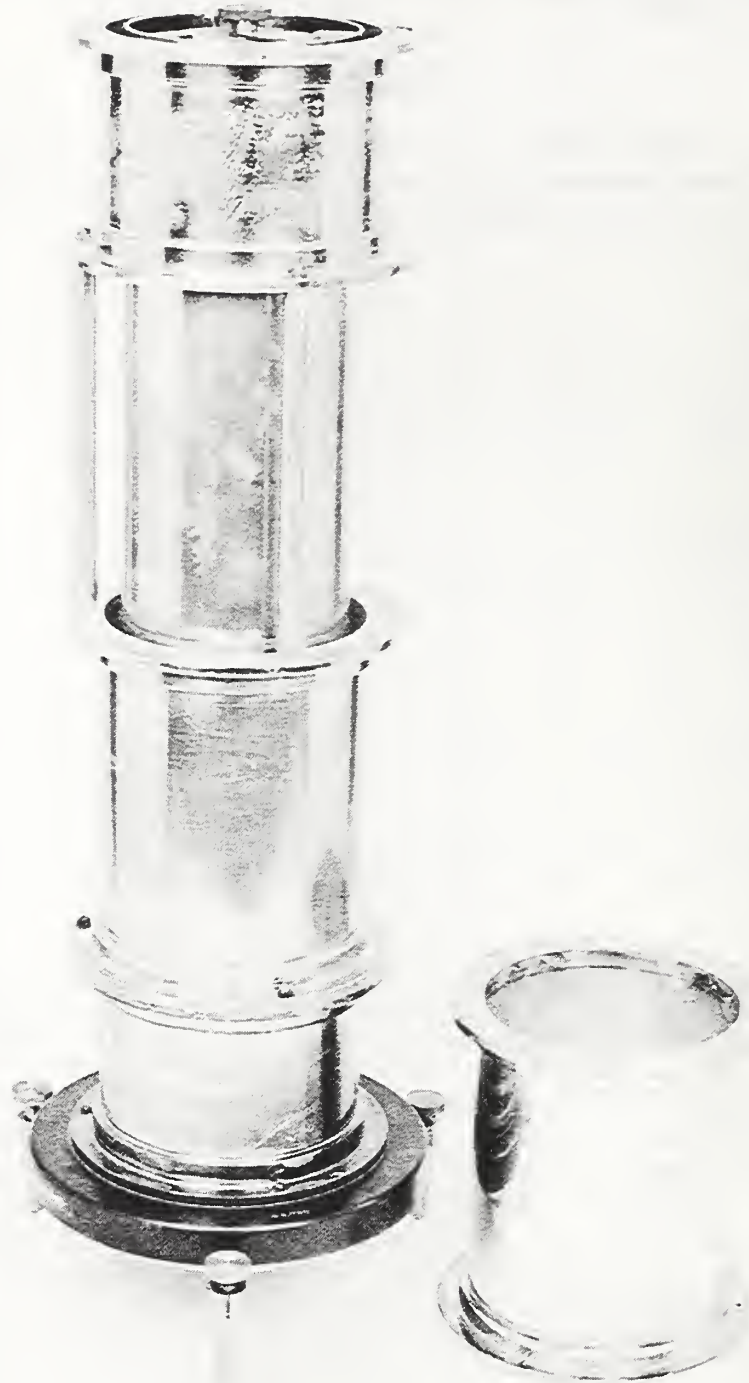

Cylindrical Capacitor (1904) M30

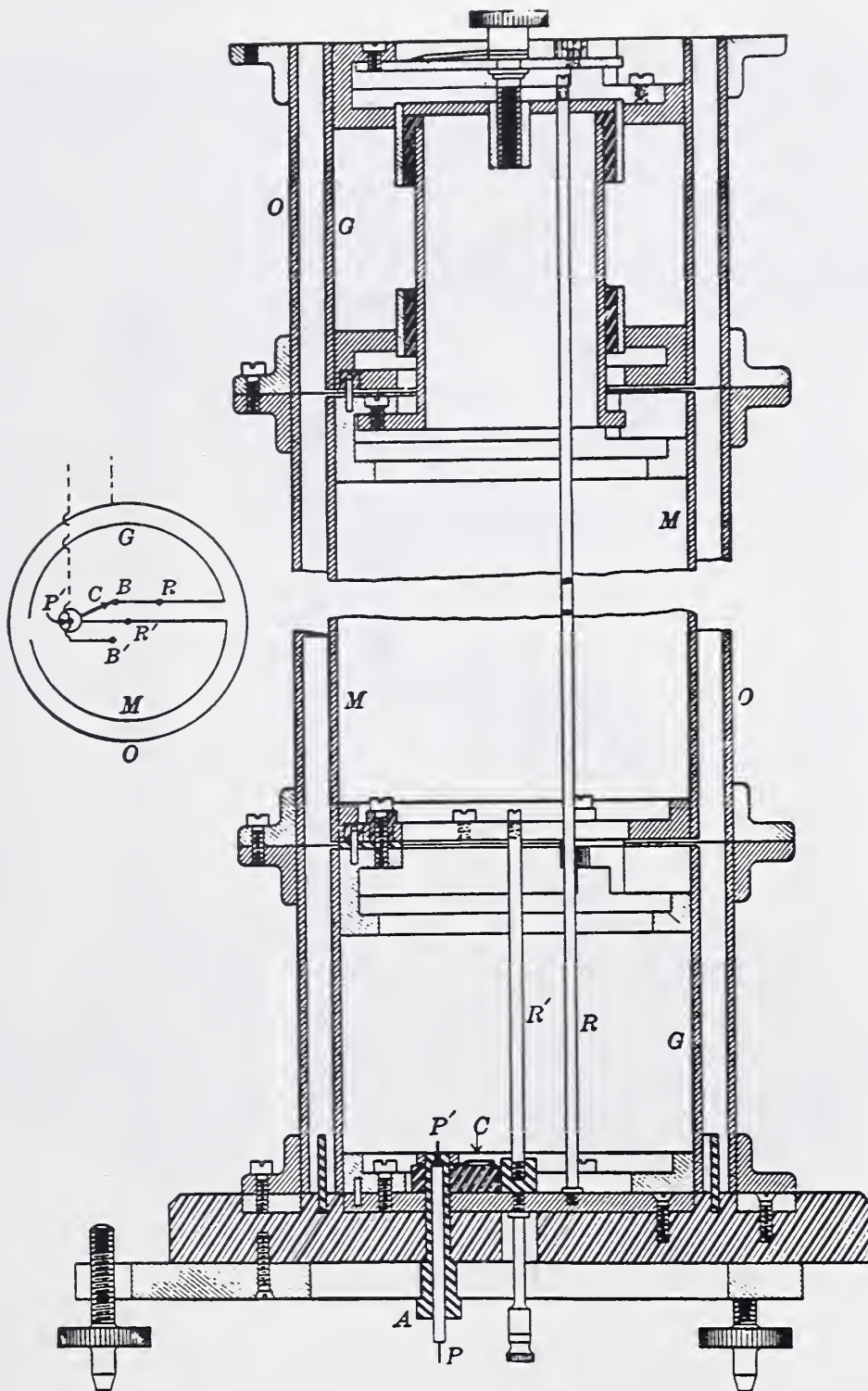

Cylindrical Capacitor (1904) M30
Schematic drawing of section

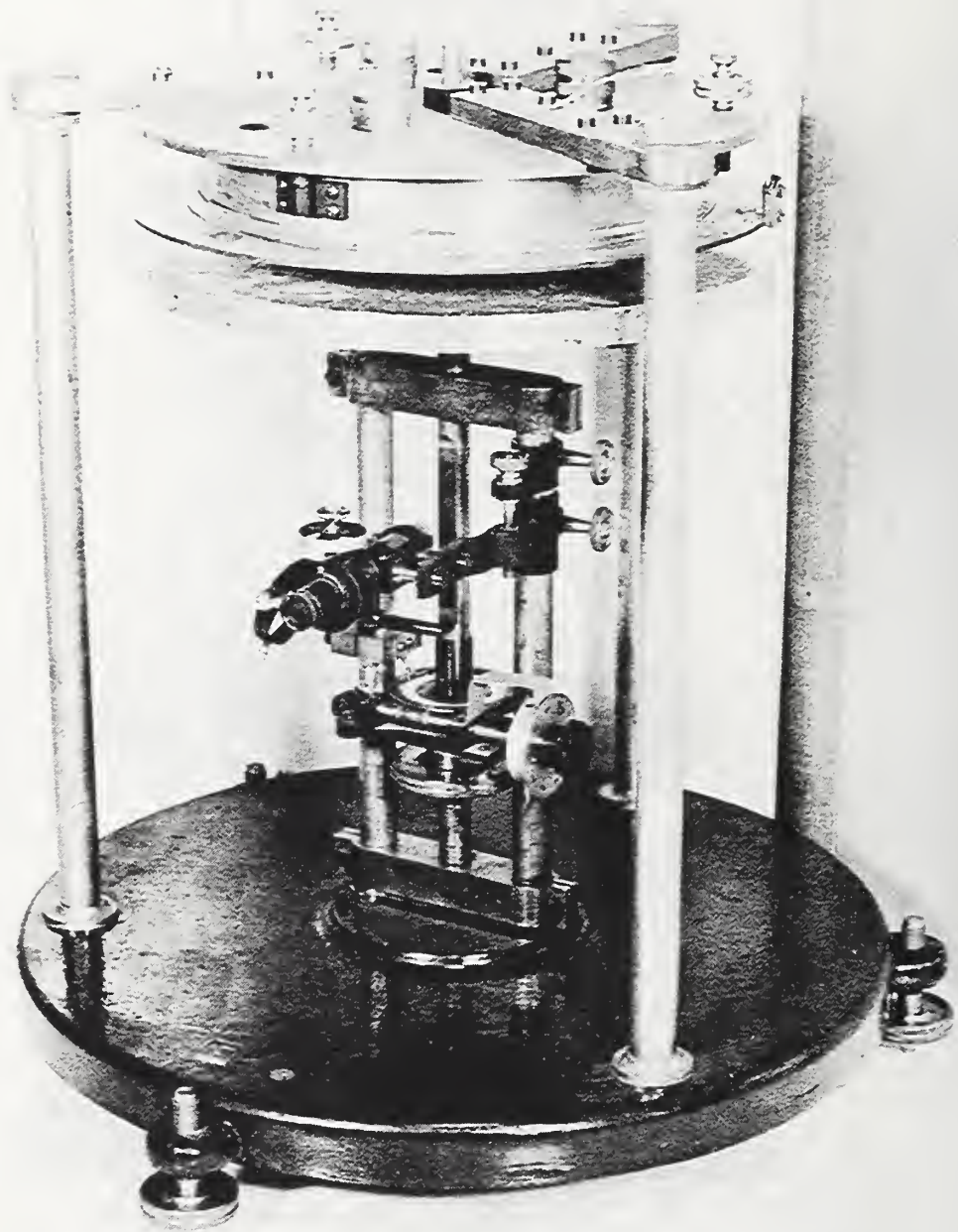

Parallel Plate Capacitor (1904) M47

This movable coil consists of 83 turns of bare copper ribbon spaced 0.6 mm apart on a porcelain cylinder, giving an average effective diameter of 75.5854 mm. Constructed at NBS, it was one of two used by Guthe for the first precise absolute measurement here of electric current by the electro-dynamometer method. It was suspended with its axis horizontal at the exact center of the opening of a much larger cylindrical coil, and at right angles to the axis of the latter. While the upper end of its torsional suspension is being twisted through 90°, an increasing current is passed through the coils until the opposing torques are balanced at the original right-angle position.

References

Guthe, K. E., A New Determination of the Electromotive Force of Weston and Clark Standard Cells by an Absolute Electro-Dynamometer, Bull. Nat. Bur. Stand. 3, 33 (1906).



Electrodynamometer Coil (1905) M68

This taut-suspension astatic electro-dynamometer was designed by H. B. Brooks over one weekend to meet an emergency request for a 50-ampere wattmeter. It served until 1925 as a standard ac-dc transfer instrument for calibrating wattmeters used on alternating current of power frequencies. Thereafter it was little used because the development of current transformers made feasible the use of 5-ampere instruments.

Connections of the two sets of fixed and moving coils were made so as to eliminate the effect of any uniform stray magnetic field. The coarse wire of the fixed coils, which may be either in series or in parallel, carried line current, while the moving coils of fine wire (in series with a large noninductive resistance) were connected in parallel with the voltage circuit of the wattmeter under test. Deflections were read by an optical lever reflecting from the small mirror attached to the suspension.

References

Harris, F. K., *Electrical Measurements*, Chapter 10, pp. 412-15
(John Wiley, N.Y., 1952).

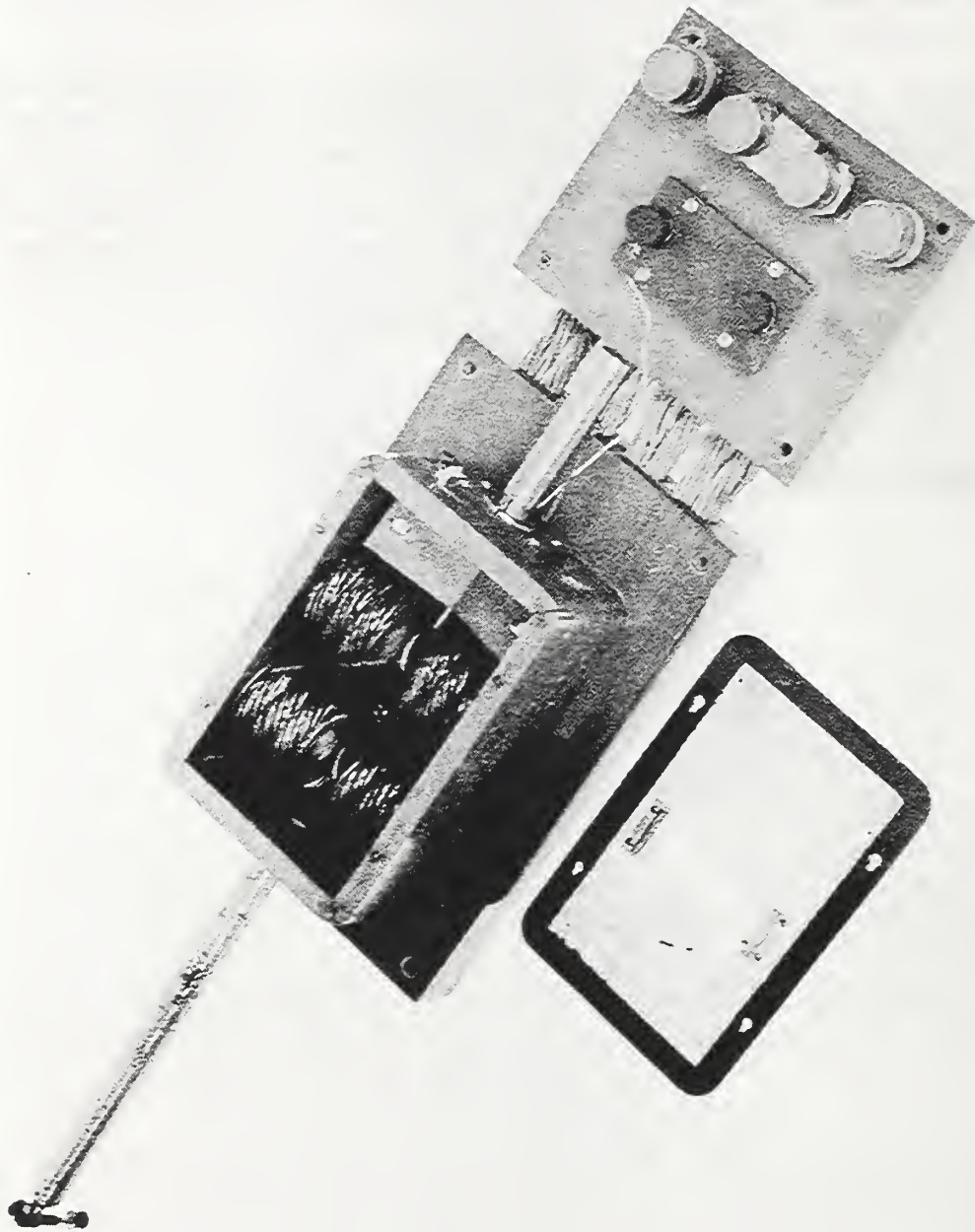

Wattmeter, Heavy Duty (1903) M366

Designed by H. B. Brooks and built by the NBS shops, this instrument combines the potentiometer principle with that of the indicating instrument. By the use of compensation for most of the unknown quantity, only the uncompensated residuum needs to be read on an indicating instrument which has a resolution no better than 0.1 scale division. The overall resolution is thus improved by two orders of magnitude. Further, since complete balance is not required, as with a null potentiometer, the instrument can follow accurately any variation of the unknown within the range of the indicator.

The device is self-contained except for a standard cell for reference and a storage cell. The main potentiometer dial covers the range from 95 to 125 volts in 15 steps of 2 volts, and a residual unbalance can be read to within 0.02 volt from the deflection of the nearly aperiodic galvanometer needle.

This instrument was used extensively for voltage measurements in the photometric laboratory over a period of thirty years, the original Weston model A being replaced by a Weston model 440 galvanometer, and later by an L & N model 8. Improved models are widely used today in instrument manufacturing plants and standardizing laboratories.

References

Brooks, H. B., A New Potentiometer for the Measurement of Electromotive Force and Current, Bull. Nat. Bur. Stand. 2, 225 (1906).

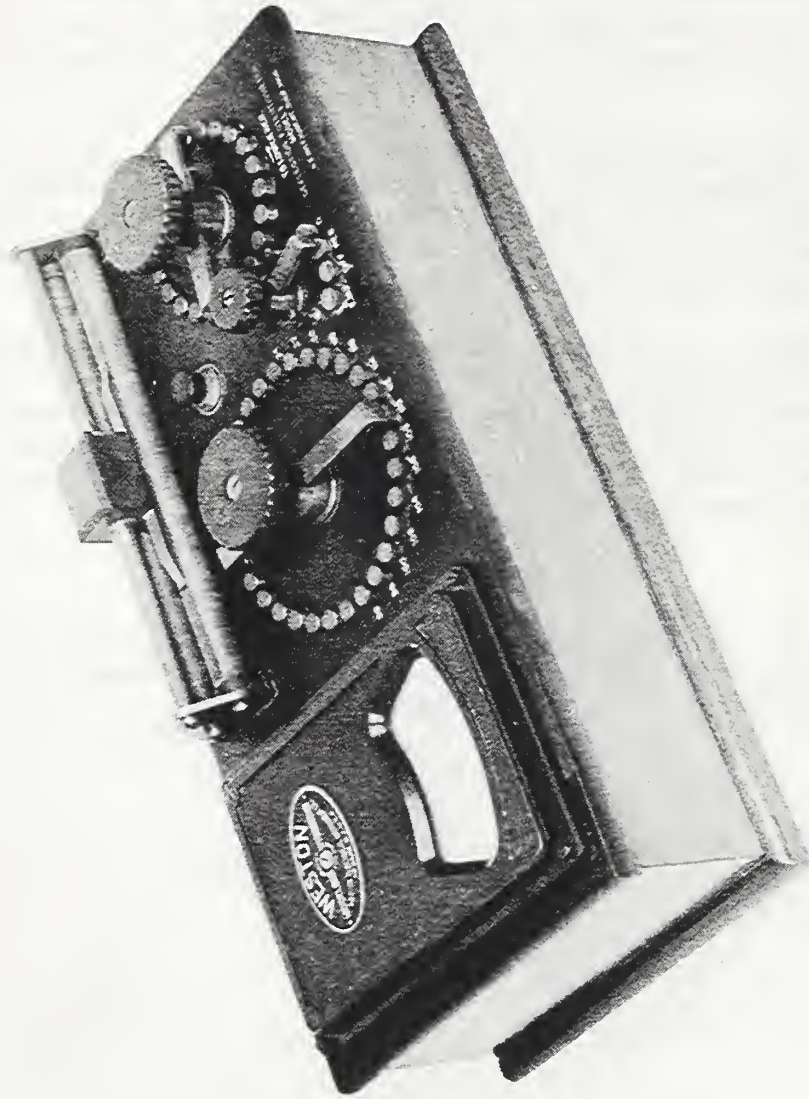

Potentiometer, Deflection (1906) M24

AREA 16 - DRUM CASE I

Defense



DEFENSE

NBS research and development for defense goes back to World War I when several hundred projects, important to the national effort, were successfully carried out. Drawing on the Bureau's broad competence in the physical sciences, the subject matter included a wide variety of aeronautical, chemical, electrical, magnetic, metallurgical, radio, photographic, and acoustic problems. During World War II the Bureau again devoted its staff and facilities to military problems in the physical sciences. Three of the principal projects were the atomic bomb, proximity fuzes, and guided missiles. Many of the techniques, methods, materials and products developed for defense later proved important in peacetime application.

A technical achievement late in World War I in which NBS was instrumental was the improvement in many components of a sound-ranging system for locating enemy artillery. The system involves installing microphones at three known stations to receive the sound pulse produced by the firing of a gun. An oscillograph at a central point recorded the instant of arrival of the sound pulses at each station. Intervals of time between pulses indicated the differences in distances from the gun to the stations. After correcting for such variable factors as temperature and wind velocity, enemy artillery could be pinpointed with such accuracy that a writer observed, "Camouflage was powerless...Actual sight of the gun could not add to the precision."

An improved oscillograph indicated the times at which the sound pulses from a gun's firing were received. It was rugged and reliable under combat conditions and gave clearer records than earlier British and French models. This oscillograph tape made on NBS equipment in France between Bois de Dapoitoux and la Grande Souche records the firing of a German 77-mm gun.

Dr. Ernest E. Weibel, a member of the NBS team that made important developments in the sound-ranging system, accompanied the equipment overseas and was killed while testing it in actual combat near Ypres.

References

War Work of the Bureau of Standards, Nat. Bur. Stand. (U.S.), Misc. Publ. 46, 265 (1921).



Sound-Ranging System (WWI) M480

NAVAL ORDNANCE STUDIES

During World War I and for some years after, an NBS team under H. L. Curtis developed both apparatus and methods for measuring such characteristics of large naval guns as muzzle velocity, time of firing and ejection, motion of projectile in the bore, and motions of the gun in recoil. Studies were conducted in experimental firings with 14-in guns on U.S. battleships.

References

Nat. Bur. Stand., Ballistic Experiments on Battleships, 1917-21.
(Unpublished reports UF820.U5)

POWDER PRESSURE GAGE

M77

This pressure gage was capable of measuring pressures up to 50,000 pounds per square inch. Fitted inside the breech block of a 14-in gun, it contained a multiply tapped resistor with spring-controlled contactor. When the gun was fired, pressure exerted on the contractor drove it past a number of the taps. A single, insulated wire extended outside to permit measurement of the change in resistance.

EXPANSOMETER

M71

Used in studying the progress of a projectile along the bore of a 14-in naval gun, a series of expansometers were clamped along the barrel of a gun by slender steel straps encircling the barrel. As the projectile passed inside, the barrel bulged and separated the contact points, thus breaking the electric circuit of each expansometer in turn causing sequenced timing signals on an oscillograph.

MUZZLE FINGER

M72

This notched, hardened steel finger was one of a pair mounted at the muzzle of a 14-in gun. It extended into a rifling groove while a longer one reached to the gun axis. The long finger was broken by the tip of the projectile, and the short finger later by the rifling band as the projectile left the gun. From these signals and the length of the shell, the projectile's velocity and time of ejection were computed.

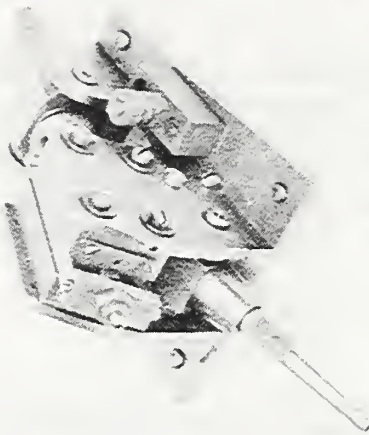

Powder Pressure Gage (WWI) M77; Expansometer (WWI) M71;
Muzzle Finger (WWI) M72

WORLD WAR II

PROXIMITY FUZES

M4, M5, M6

A major technical development during World War II was the variable time (VT) or proximity fuze which causes a shell, bomb, or rocket to explode when merely in effective proximity to its target, rather than on impact. Three kinds of fuzes for nonrotating projectiles were developed at NBS while the Johns Hopkins Applied Physics Lab developed a fuze for rifled artillery shells. The Photoelectric fuze T-4 (M4), for use on the M-8 antiaircraft rocket, is equipped with a photoelectric cell and lens and is triggered by changes in light intensity when an object passes between the lens and the sky. Work on this fuze was discontinued as the radio fuzes showed more promise. The T-89 (M5) first used in early 1945 is a tiny radio sending and receiving station mounted in the nose of an aircraft bomb or rocket. When its continuously emitted waves reach a target, they are reflected back to the receiver. At a predetermined distance, the reflected waves reach a certain intensity, and an electronic switch detonates the fuze. The T-171 (M6) developed around 1944 triggers trench mortar shells at a predetermined height above their target. It was similar to the T-89, but was modified to withstand the shock of being fired from the mortar.

References

- Summary Technical Reports, Nat. Def. Res. Comm. Div. 4, Vols. 1 and 3, U.S. Office Sci. Res. & Dev. (1946).
- Hinman, W. S. and Brunetti, C., Radio proximity fuse design, Nat. Bur. Stand. (U.S.), J. Res. 37, 1, RP1723 (1946).

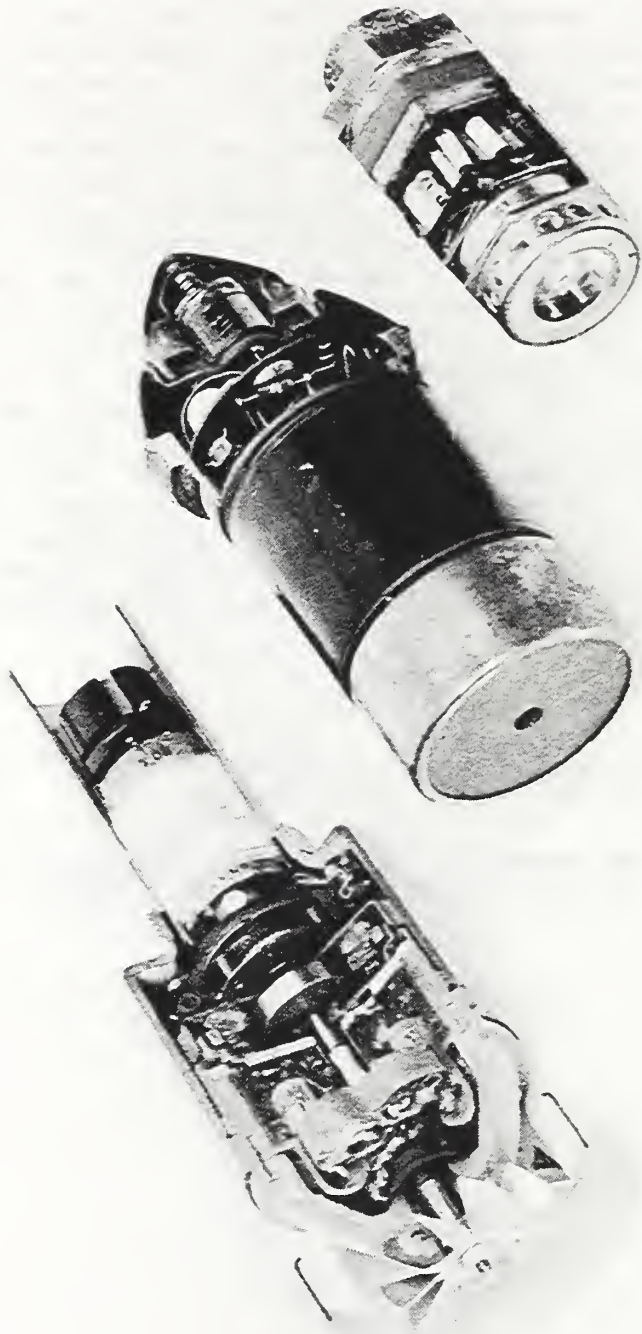

Proximity Fuzes (WWII) M5, M4, M6

Developed by M. Shepherd at NBS to detect small amounts of carbon monoxide in airplane cockpits, these tubes contain a silica gel of palladium sulfate and ammonium molybdate which changes color if carbon monoxide is present. More sensitive and reliable than previous detection devices, over a half million of these tubes were made at NBS during World War II.

References

Shepherd, M., Rapid determination of small amounts of carbon monoxide, Anal. Chem. 19, 77-81 (1947).

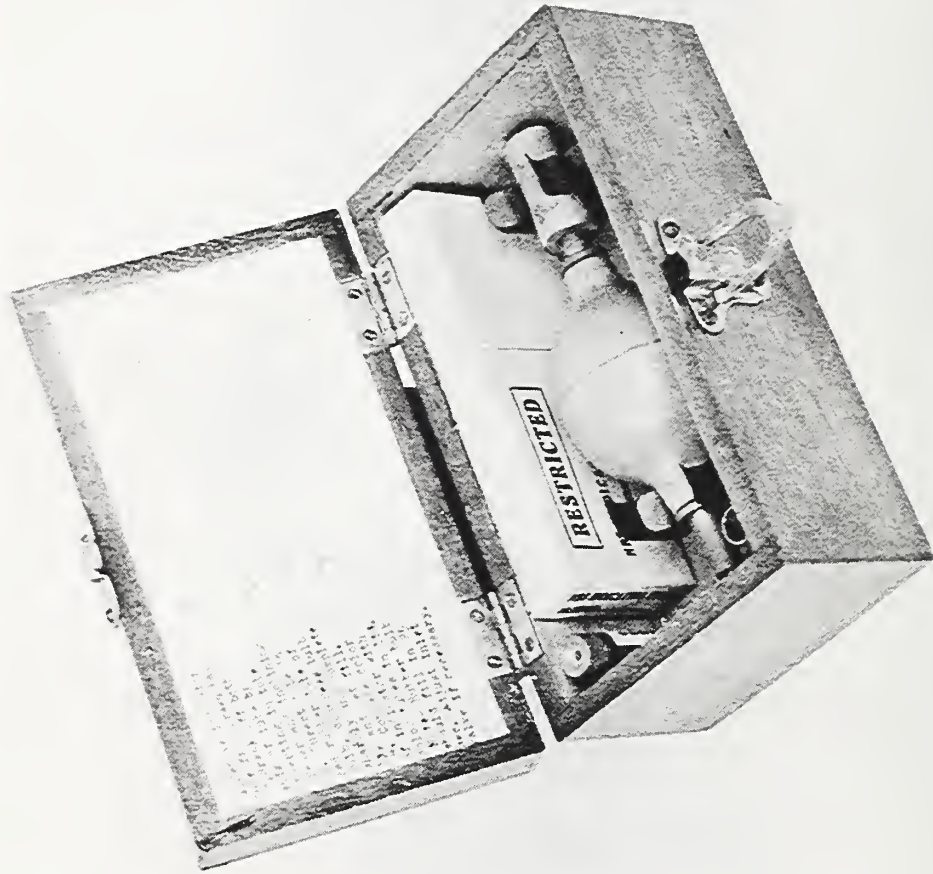

Carbon Monoxide Detector Tubes (WWII) M193

This device is the electrical circuit assembly of one type of Sonar Buoy used in antisubmarine warfare. It is contained in a buoy, several of which can be dropped from an aircraft in a known pattern in an area where enemy submarines are suspected. A microphone suspended below the buoy picks up any underwater noise and feeds its electrical signal to the input to this circuit. The signal is amplified and used to modulate the carrier of an HF transmitting circuit, energized by external dry cells, and feeding an antenna extending several feet above the buoy. By tuning successively to the various buoys in the pattern, the aircraft can recognize and estimate the location and direction of motion of a submerged submarine.

This circuit assembly is an early example of the type of modular construction developed by the NBS "Tinkertoy" Section under the sponsorship of the Navy Department during and after World War II, and under the initial leadership of Mr. Robert Henry. This section had developed automatic machinery for manufacturing the individual ceramic wafers, imprinting an appropriate electrical component or circuit on each, and assembling them by riser wires in larger modules. Mass production of complex circuitry with a minimum of labor was thus made possible, and it served as a stimulus to many private companies to follow similar procedures.

After the circuits had been "translated" by NBS from the older Navy forms to this modular type, about 3,000 sample circuits were produced on contract by Sanders Associates for evaluation studies by the Navy's AN/SSQ-2 Sonabuoy.

References

PROJECT TINKERTOY: Modular design of electronics and mechanized production of electronics, Nat. Bur. Stand. (U.S.), Tech. News Bull. 37, No. 11, 161 (Nov. 1953).

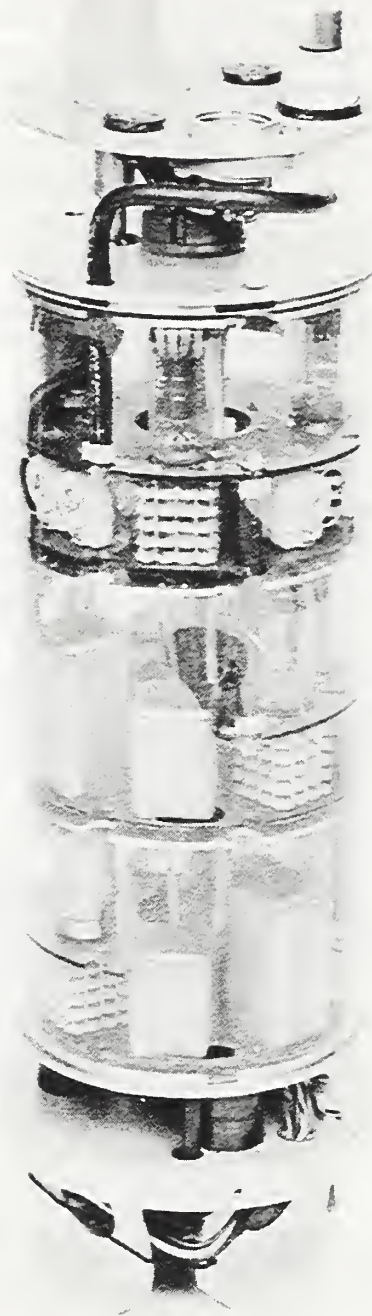

Buoy Circuit Assembly, (Tinkertoy) (1953) M443

Invented at NBS by Charles Moon and R. L. Driscoll during World War II, this apparatus was attached to a free-floating mine to keep it at a nearly constant, predetermined depth. When it deviated from that depth, a pressure-sensitive device started a small propeller which returned the mine to the set depth and readjusted the buoyancy of the system by changing the volume of an extensible chamber. In 1944 and 1945 more than 250 such mines were dropped from aircraft into the Chindwin and Yangtze Rivers to interfere with Japanese shipping.

References

U.S. Patent No. 3012502

Duncan, R. C., America's Use of Sea Mines, U.S. Naval Ord. Lab., p. 144 (1962).

NBS War Research: The National Bureau of Standards in World War II, p. 60 (1946).

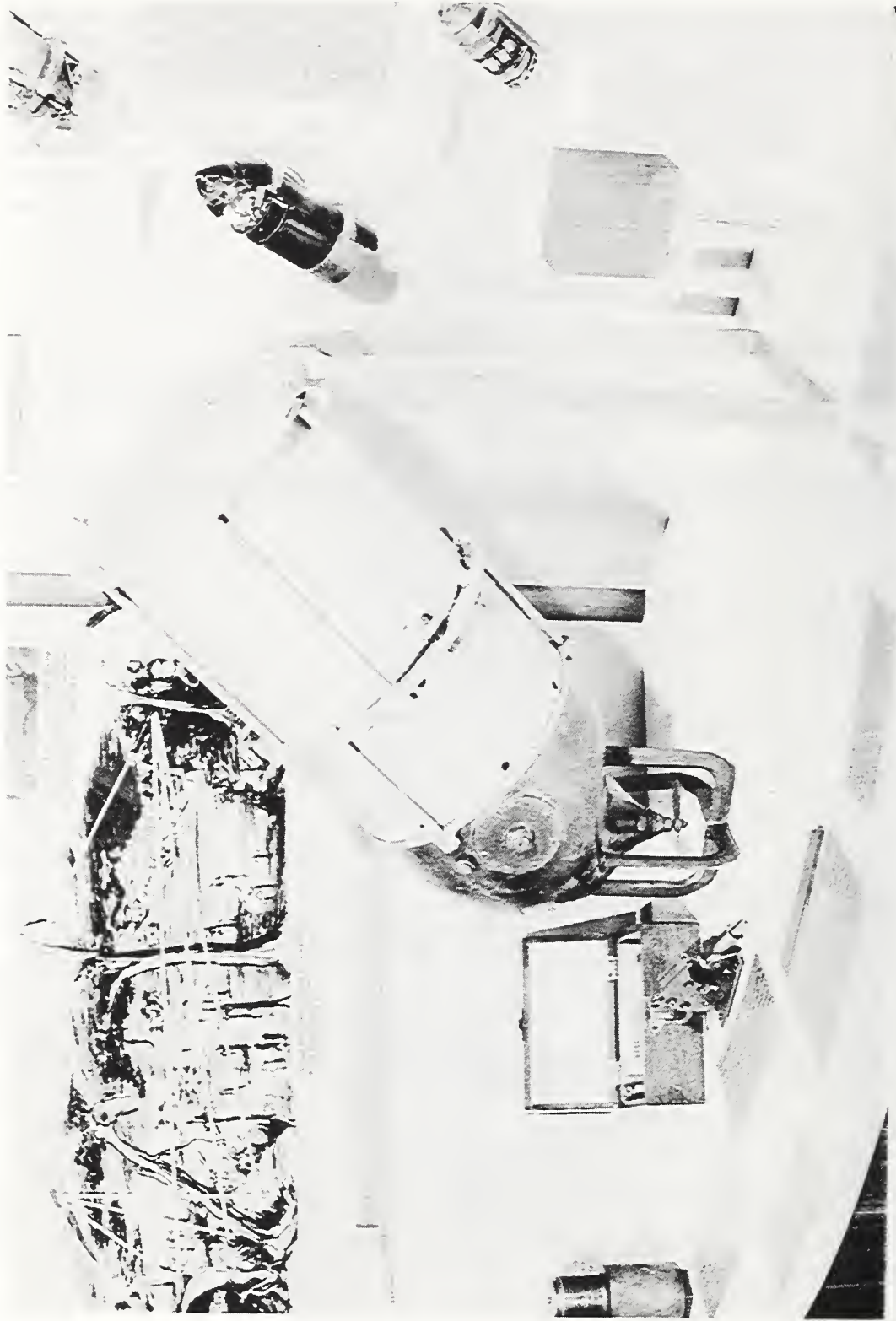

Constant Depth Mine (WWII) M100

Crystals of uranyl nitrate used in an ether extraction method for purifying uranium oxide were developed by J. I. Hoffman and J. Scherrer of NBS in 1941. This process permitted commercial production of uranium to a degree of purity seldom achieved even on a laboratory scale. It was an important breakthrough in the atomic weapons program.

References

Smyth, H. D., Atomic Energy for Military Purposes, p. 93 (Princeton Univ. Press, 1945).

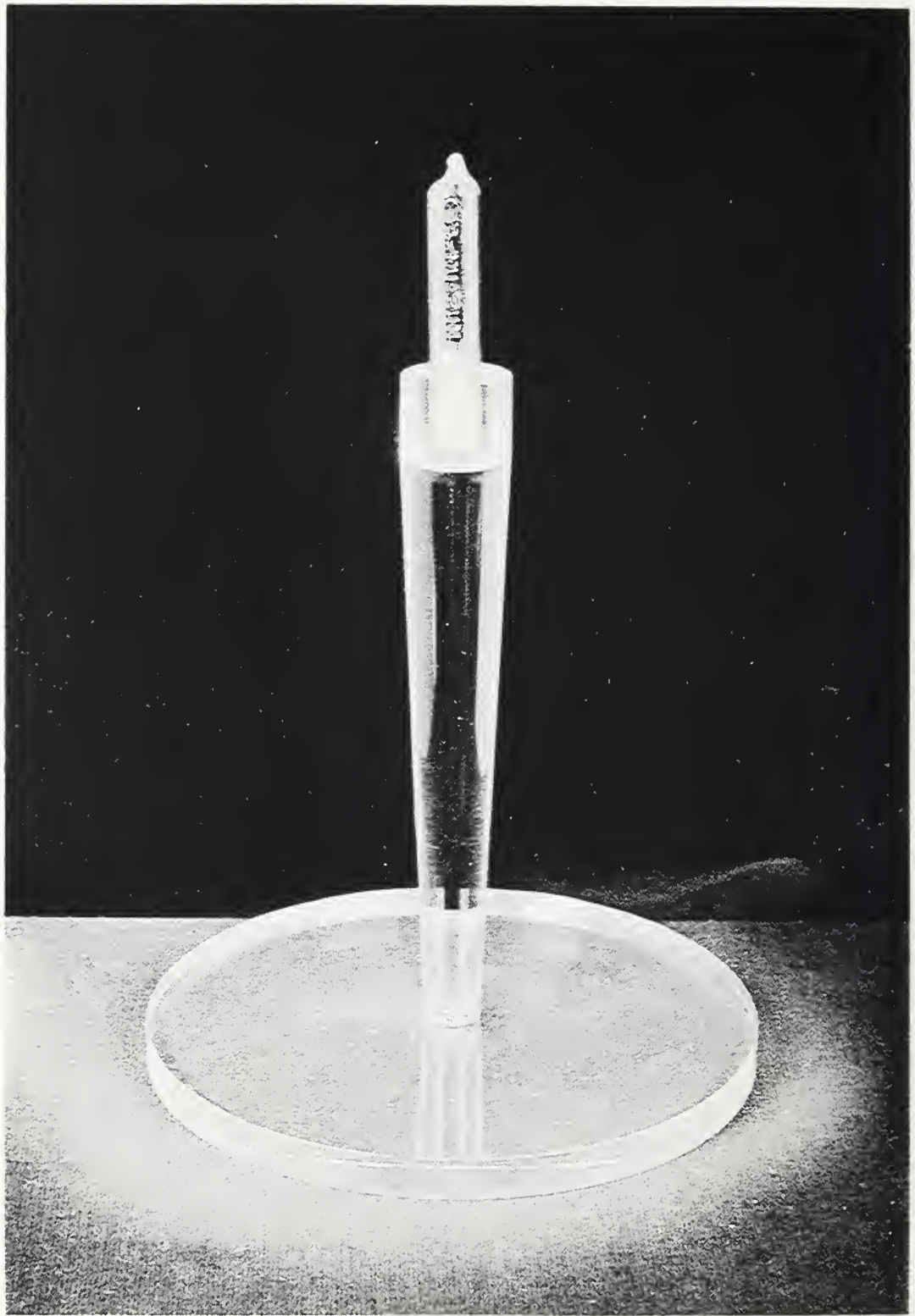

Uranyl Nitrite Crystals (1941) M82

High purity graphite similar to the material tested in quantity at NBS in the early 1940's to insure almost complete absence of neutron-absorbing impurities. The graphite used in the early nuclear reactors was found to contain boron, which prevented a chain reaction. C. J. Rodden and other NBS men patiently studied the various steps in the manufacture of graphite and discovered and eliminated the source of the boron.

References

Smyth, H. D., Atomic Energy for Military Purposes, p. 94 (Princeton Univ. Press, 1945).

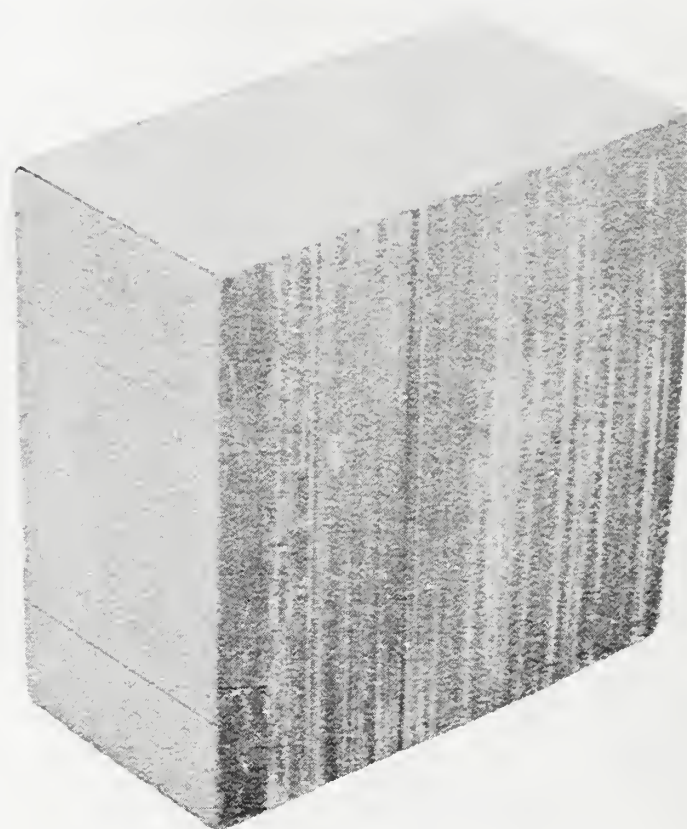

Graphite Block (WWII) M81

AREA 17 - DRUM CASE I

Industry



INDUSTRY

NBS has contributed substantially through its testing activities to the advance of commerce and industry. At the request of various industries, Government agencies, and other organizations, the Bureau invented and developed apparatus and methods for testing a wide variety of materials and equipment. Such testing not only directly benefited science and industry but resulted in better products for the consumer.

The duty levied on sugar imports by the U.S. Customs Service is based on the readings taken on an instrument of this type, graduated to the International Sugar Scale. On that scale, 100 °S refers to the optical rotation of a beam of polarized light measured on passing through a 200-mm tube filled with a solution prepared with 26.00 g of pure sucrose dissolved in water to a volume of 100 ml at 20 °C.

In a saccharimeter, the observer's field of view is divided, half showing the optical rotation of the sugar solution, and half showing the opposite rotation effected by a compensating pair of quartz wedges. The observer seeks to obtain a photometric match between the two fields. The planes of polarization in the two fields differ by the so-called halfshade angle. In the conventional instrument, the halfshade angle is fixed at 6 to 8 degrees, a compromise intended to provide adequate illumination of the fields when testing a dark molasses, and satisfactory precision when a clear solution is being tested. In this model, designed by F. J. Bates at NBS and constructed by Fric of Prague, a halfshade angle from 2.5 to 15 degrees can be selected by the knurled ring just below the eyepiece, thus providing an adjustable sensitivity. A modified gear train resets the zero position of the analyzing prism. The knurled knobs marked C and N adjust the quartz wedges used to match the fields. A concentrated-filament incandescent lamp, fitted with a potassium dichromate filter which eliminates the blue end of the spectrum where the quartz compensation is less effective, provides an improved white-light source.

References

- Bates, F. J., A Quartz Compensated Polariscopes with Adjustable Sensibility, Bull. Nat. Bur. Stand. 4, 461 (1908); 5, 193 (1908).
- Bates, F. J., et al., Polarimetry, Saccharimetry, and the Sugars, Nat. Bur. Stand. (U.S.), Circ. 440, 810 pages (1942).

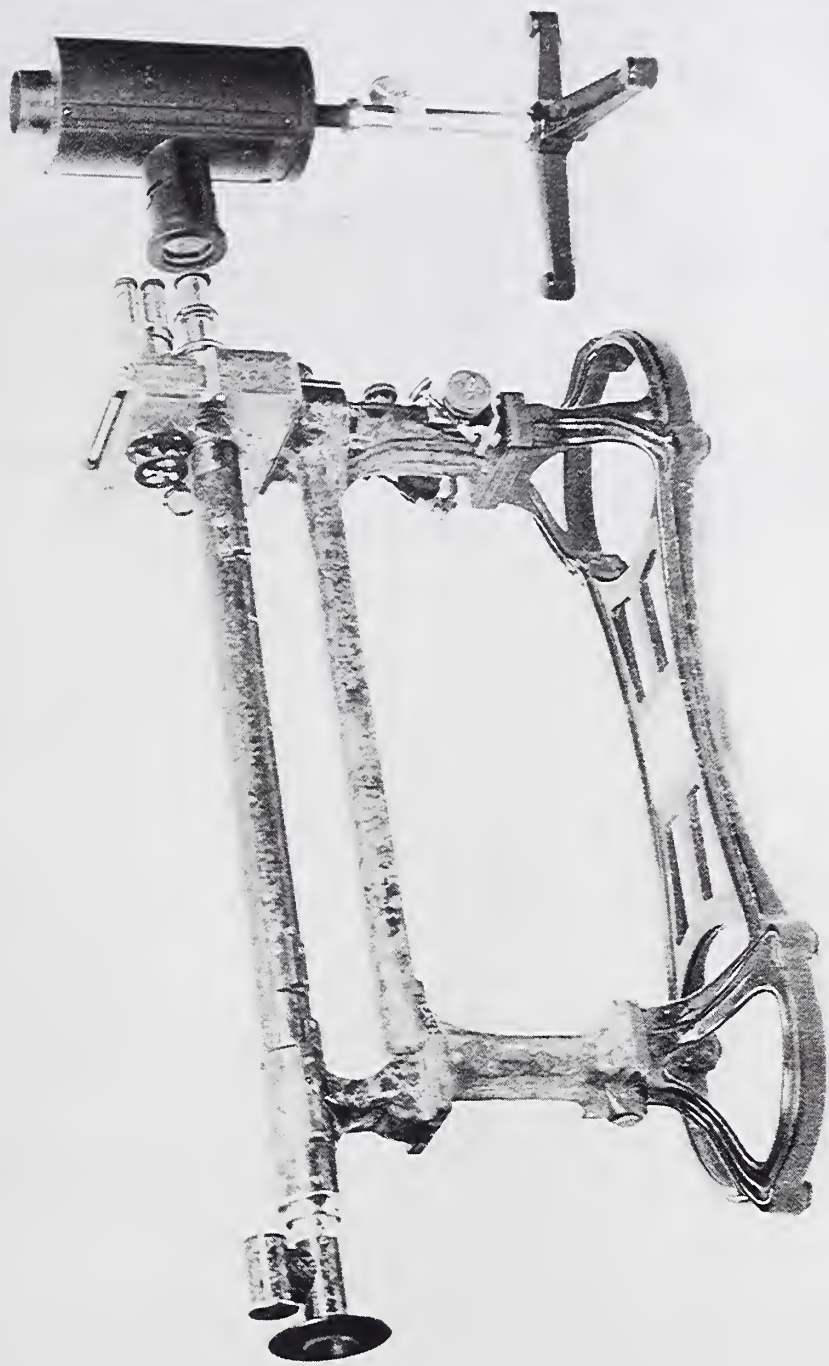

Saccharimeter, Bates (1907) M418

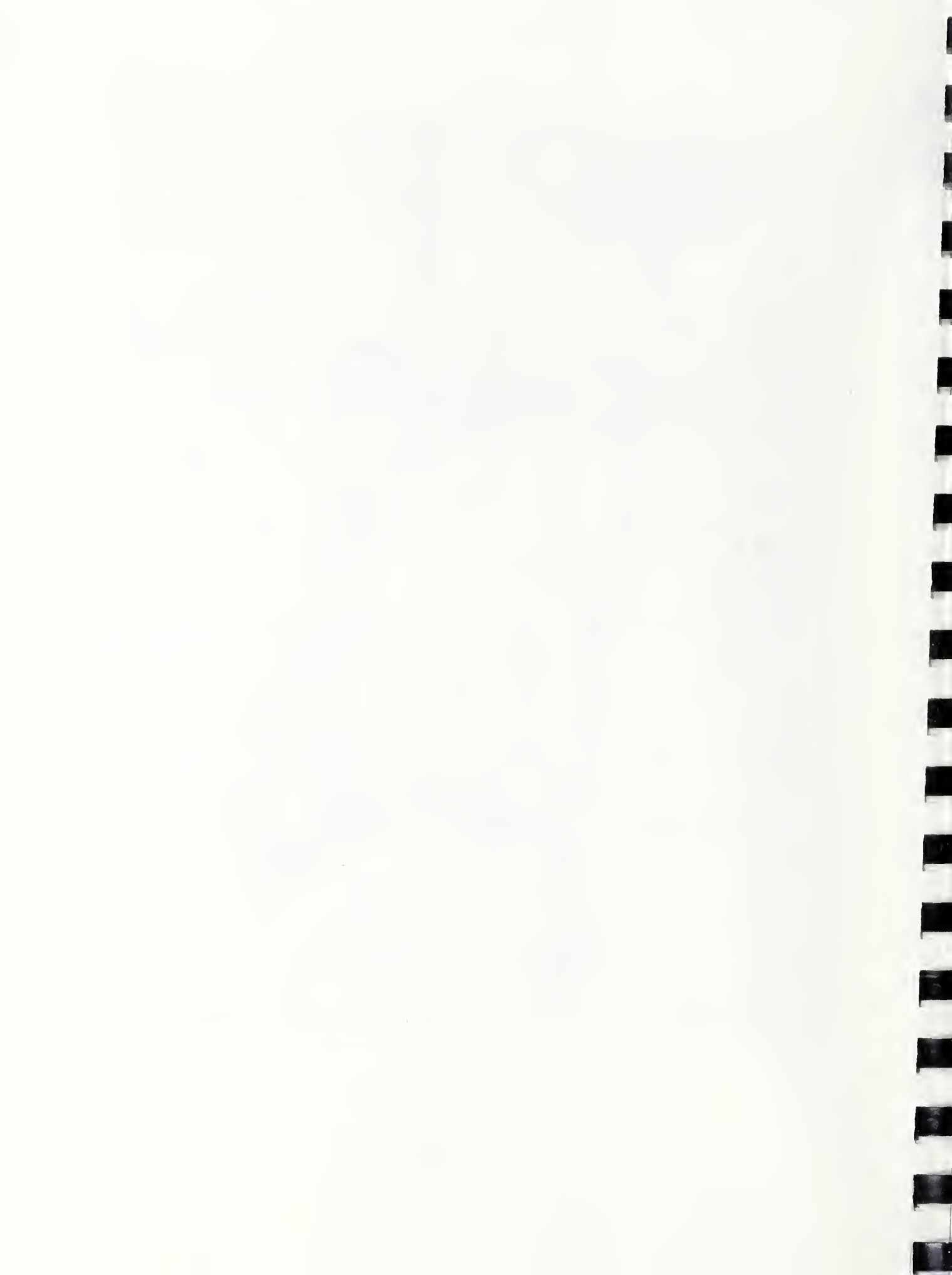

----- In the device developed by H. F. Schiefer the stiffness of a fabric is related to the energy required to fold a pair of rectangular specimens. Similarly, the elastic energy recovered upon unfolding is a measure of resiliency, an important property of parachute fabrics. The difference, or hysteresis energy, is related to wrinkleability.

The flexometer has been useful for the evaluation of the effects of different kinds of fiber, yarn, and fabric constructions, and of finishing treatments. It was especially valuable in studying the effect of resin finishes on wrinkle resistance, and in developments leading to wash-and-wear garments.

References

Schiefer, H. F., The flexometer, an instrument for evaluating the flexural properties of cloth and similar materials, Nat. Bur. Stand. (U.S.), J. Res. 10, 647, RP555 (1933).

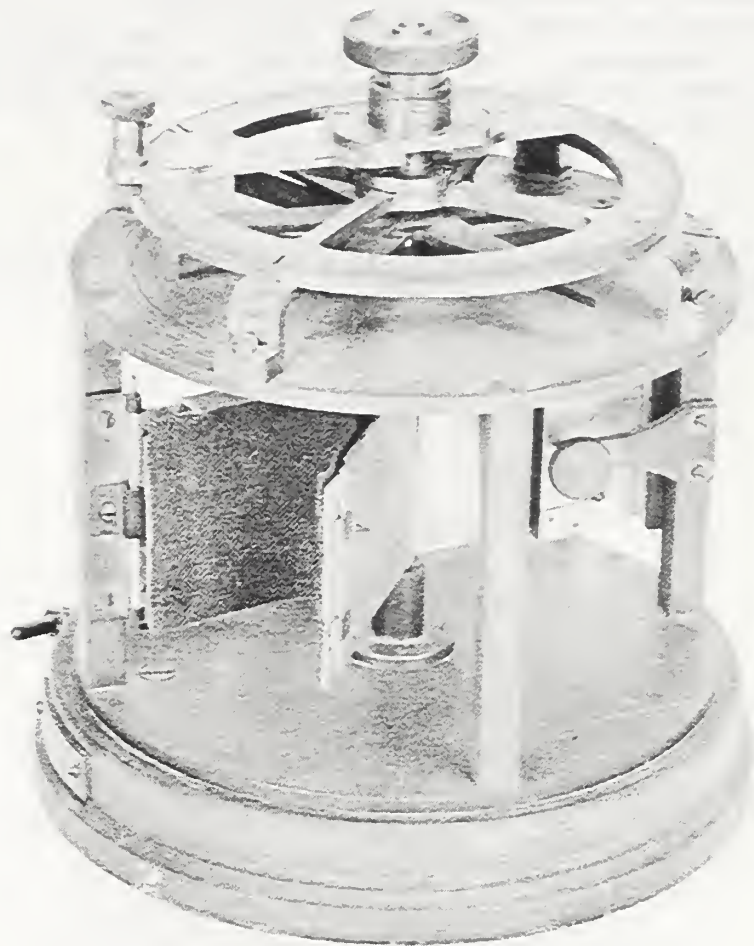

Flexometer (1930) M331

This instrument was developed by E. C. Dreby to provide objective evaluation of the "hand" or "feel" of fabrics--a characteristic dependent on the free space between yarns and the flexural stiffness of the yarns themselves. The ends of a strip of fabric are clamped under tension, and then one end is moved laterally until the strip wrinkles. The measurement is related to pliability, drapability, and appearance, and is useful in fabric design and in the evaluation of finishing processes on fabrics of similar construction.

References

- Dreby, E. C., The planoflex, a simple device for evaluating the pliability of fabrics, Nat. Bur. Stand. (U.S.), J. Res. 27, 469, RPl434 (1941).

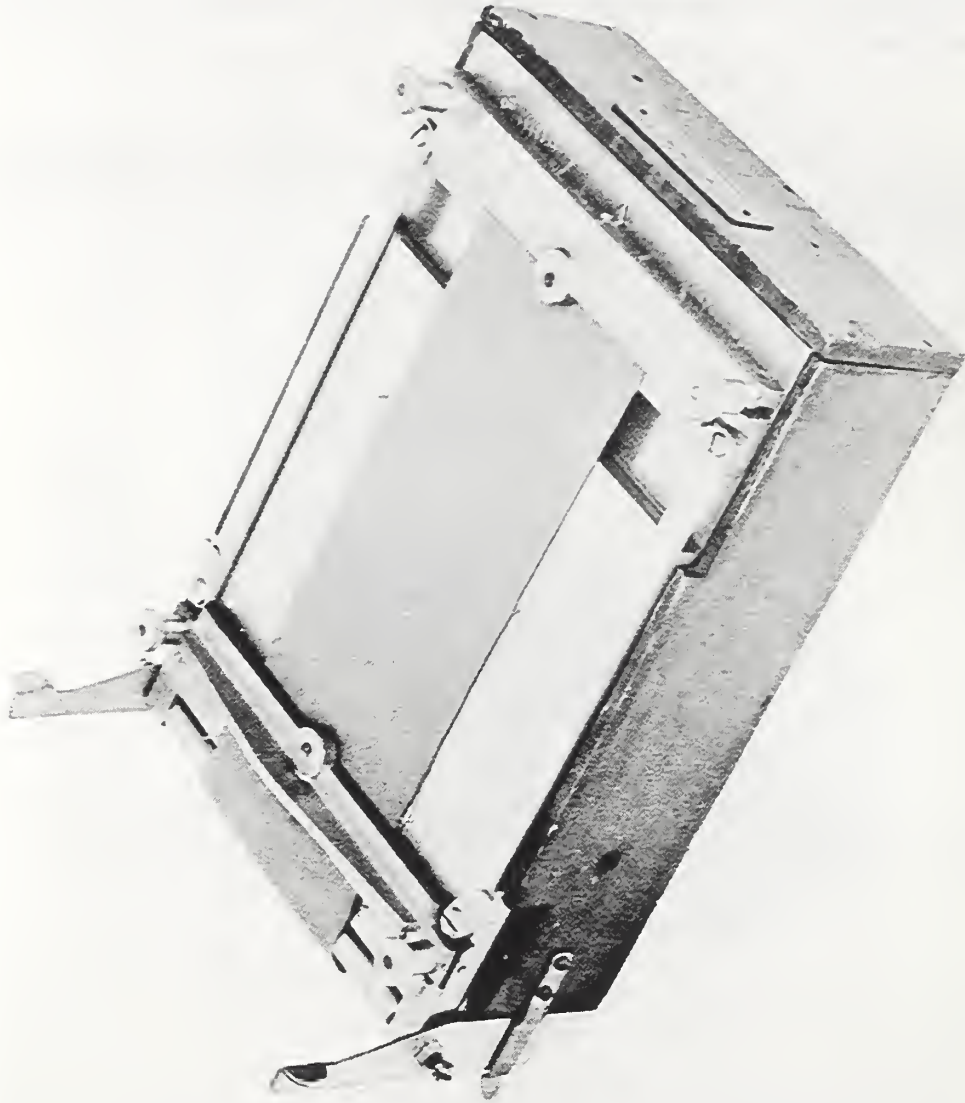

Panoflex (1940) N332

U.S. Patent 2,091,995 covers a four-sided pyramidal diamond indenting tool, two of its opposite cutting edges having an included angle smaller than the other two. This tool makes an elongated diamond-shaped impression that is long enough to give consistent measurements of hardness in thin materials such as dental enamel or sheet metal, even when light loads are used. It is useful for elastic materials because only minor distortion is produced at the ends of the elongated indentation, but it can equally well be used for plastic materials such as waxes, or brittle materials such as glass.

The mechanism shown (M155) was specifically designed for light loads; it includes a cam-controlled weighted arm for applying a known load. Three samples of the indenting tool are laid at the side.

References

- Knoop, F., Peters, C. G., and Emerson, W. B., A sensitive pyramidal-diamond tool for indentation measurements, Nat. Bur. Stand. (U.S.), J. Res. 23, 39, RP1220 (1939).
- Tarasov, L. P. and Thibault, N. W., Determination of Knoop hardness numbers independent of load, Trans. Am. Soc. Metals 38, 331 (1947).

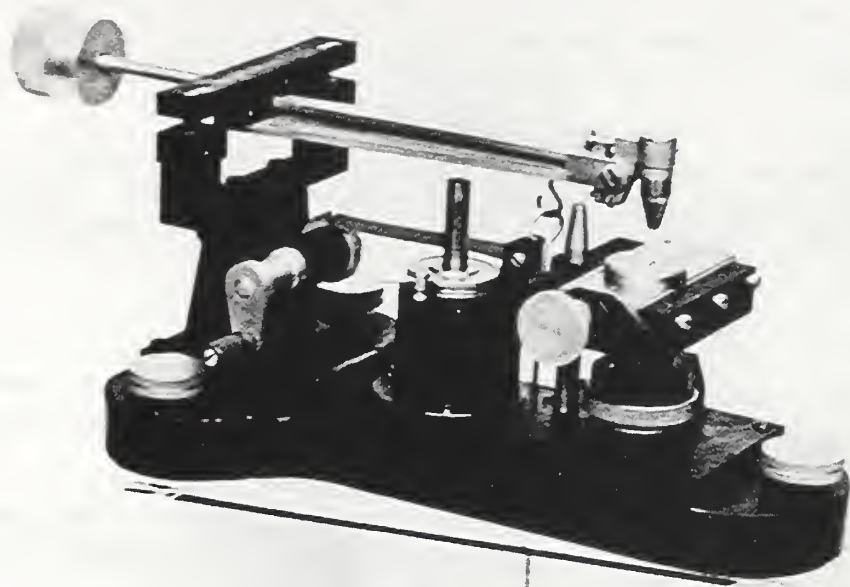

Knoop Indenter (1936) M155

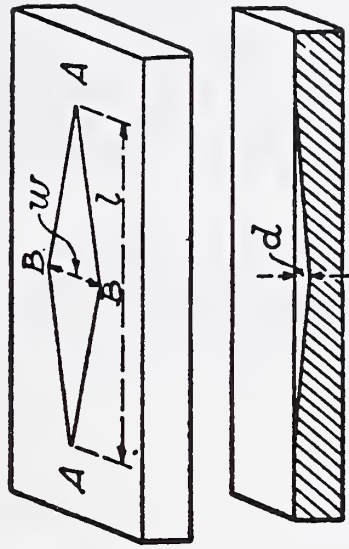
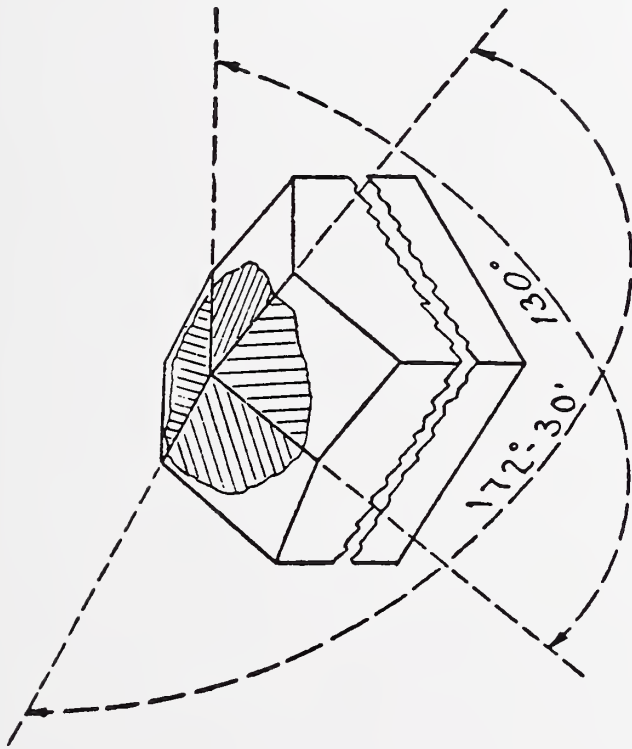

Knoop Indenter (1936) M155
Schematic drawing of diamond indenting tool

Excessive internal stress in electroplated coatings may cause peeling, blistering, or cracking of the deposit. This instrument developed by Abner Brenner measured internal stress as it develops in the plating process, and has been widely used both for research and for production control in the plating industry. It permits study of such variables as composition of the bath and grain size of the deposit.

The coating is applied to one surface of a copper or stainless steel helical strip 0.25 to 0.75 mm thick. As deposition occurs, the helix coils or uncoils slightly, and the rotation is magnified by 10:1 gearing. After stripping, the helix may be used again and again.

References

U.S. Patent 2,568,713.

Brenner, A. and Senderoff, S., A spiral contractometer for measuring stress in electrodeposits, Nat. Bur. Stand. (U.S.), J. Res. 42, 89, RP1953 (1949).



Spiral Contractometer (1947) M416

Early in the century NBS cooperated with the Bureau of Engraving and Printing in developing improved intaglio plates for printing currency. In 1930, C. T. Thomas and W. Blum worked out a process of electrodepositing nickel, iron, and chromium to provide wear resistance, with a thick steel backing to limit distortion. In 1966, the method was modified to adapt the plates for use in rotary presses.

References

Thomas, C. T. and Blum, W., The production of electrolytic iron printing plates, Trans. Am. Electrochem. Soc. 57, 59 (1930).

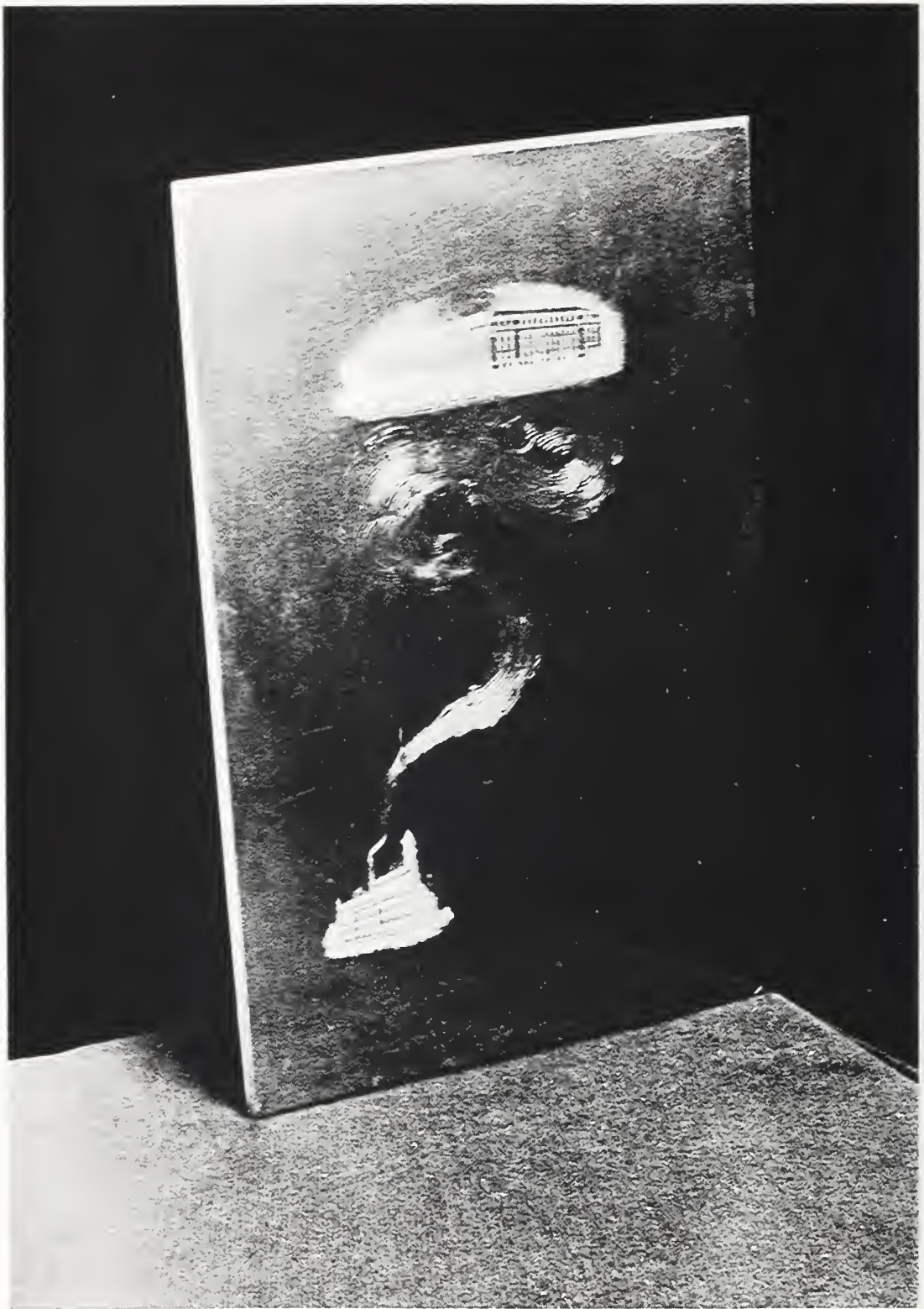

Electroformed Printing Plate (1930) M441

AREA 18 - DRUM CASE I **Science** 

SCIENCE

NBS research in diverse areas of physics, mathematics, chemistry, metallurgy and engineering has had one single unifying theme: precise measurement of natural phenomena. The resultant knowledge, instruments, measurement techniques, and reference data have contributed significantly to the advance and growth of science.

In this twin microcalorimeter using Peltier-effect cooling to balance the rate of energy emission of small radioactive sources, precise comparison can be made between samples held in the two small cylindrical copper (or gold) "cups." As designed by W. B. Mann to utilize a principle suggested by H. L. Callendar in 1911, two constantan-chromel wires soldered to the lower end of each cup form the Peltier junction, while similar pairs of wires form a thermocouple for measuring the cup temperature.

The calorimeter is used in the vertical position, with the larger aluminum (or copper) block uppermost. Each cup is supported on the upper end of a six-junction chromel-constantan thermopile by means of an equatorial annular ring, and this entire assembly is mounted on an insulating plate supported in the copper disk mount. The lower junctions of each thermopile dip into silicone vacuum-pump oil contained in the cavities of the lower block.

The Peltier junctions, with coefficient P , are connected in opposition so that one cup is heated and the other cooled when a current C flows in that circuit. With a radioactive source in one cup (or one in each) the current is adjusted until equal temperatures are achieved in each. The difference in rate of energy emission is then given by $2 PC$ watts, to within about $0.3 \mu\text{W}$ over a range of $100 \mu\text{W}$ to 10 mW .

A similar microcalorimeter was used to intercompare the national radium standards of Britain, Canada, Germany and the United States; to calibrate the samples used to prepare solution standards of radium; to determine the activity of hydrogen 3 (tritium); sulfur 35, nickel 63, polonium 210; and to measure the energy output of plutonium 239.

References

- Mann, W. B., A radiation balance for the microcalorimetric comparison of four national radium standards, Nat. Bur. Stand. (U.S.), J. Res. 53, 277 (1954).
- Mann, W. B., Radiation calorimetry--A review of the work at NBS, Nuclear Instr. Meth. 112, 273 (1973).

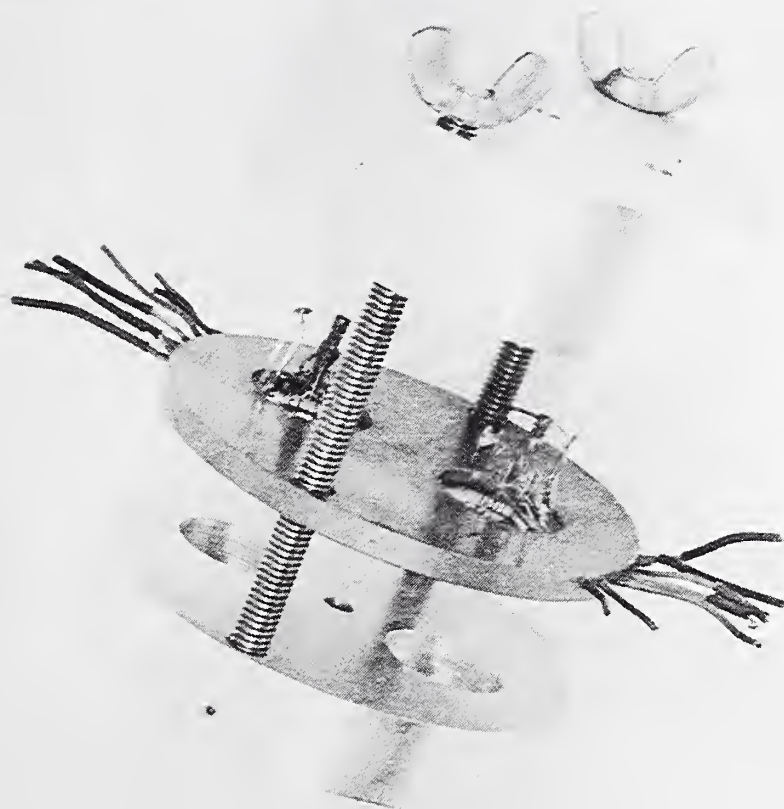

Microcalorimeter (Radiation Balance) (1952) M339

This calorimeter was designed and used by Osborne, Stimson, and Ginnings in 1937 for precise measurement of heat capacity and heat of vaporization of water from 0 to 100 °C. The nearly spherical inner shell (cut away to show the construction) holds the water sample, which submerges the rotating stirrer and electric heater. The space just outside that shell is evacuated to reduce heat loss. The double-walled outer shell holds a nearly isothermal steam bath, and an extension of the steam jacket surrounds the reference temperature block (shown through the oval cutout) which holds a platinum resistance thermometer and the reference junctions of the auxiliary thermocouples.

References

- Osborne, N. S., Stimson, H. F., Ginnings, D. C., Measurements of heat capacity and heat of vaporization of water in the range 0° to 100 °C, Nat. Bur. Stand. (U.S.), J. Res. 23, 197, RP1228 (Aug. 1939).

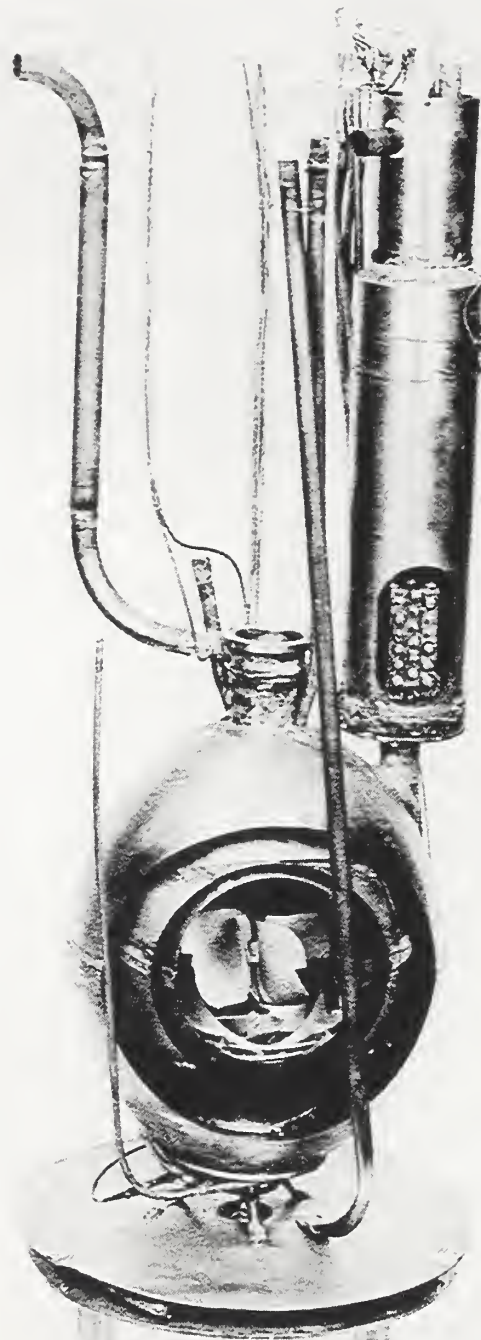

Water Calorimeter (1937) M509

The accurate measurement of large compressive and tensile forces has been made practicable by the Whittemore-Petrenko elastic proving ring, developed about 1925 to provide calibration of mechanical testing machines for structural members and machine parts. When the ring is loaded along a vertical diameter, its change of shape is measured by means of a micrometer screw and a thin flexible reed, each of which is attached to the ring at the neutral axis where the stress is negligible. The reed is set to vibrating by pushing its free end to one side, and the micrometer screw is then advanced so that its tip "buzzes" the moving end of the reed. The deflection of the ring can thus be read with a sensitivity of a few hundredths of a millimeter, and an accuracy within 0.1 percent.

The unit displayed was designed for compression loads, and made in the NBS shop. Today this type of proving ring is made by several commercial firms in sizes from 200 to 1,500,000 pounds force.

References

U.S. Patent 1,648,375 and 1,927,478, H. L. Whittemore and S. N. Petrenko.

Wilson, B. L., et al., Proving Rings for Calibrating Testing Machines, Nat. Bur. Stand. (U.S.), Circ. C454 (Aug. 1946).

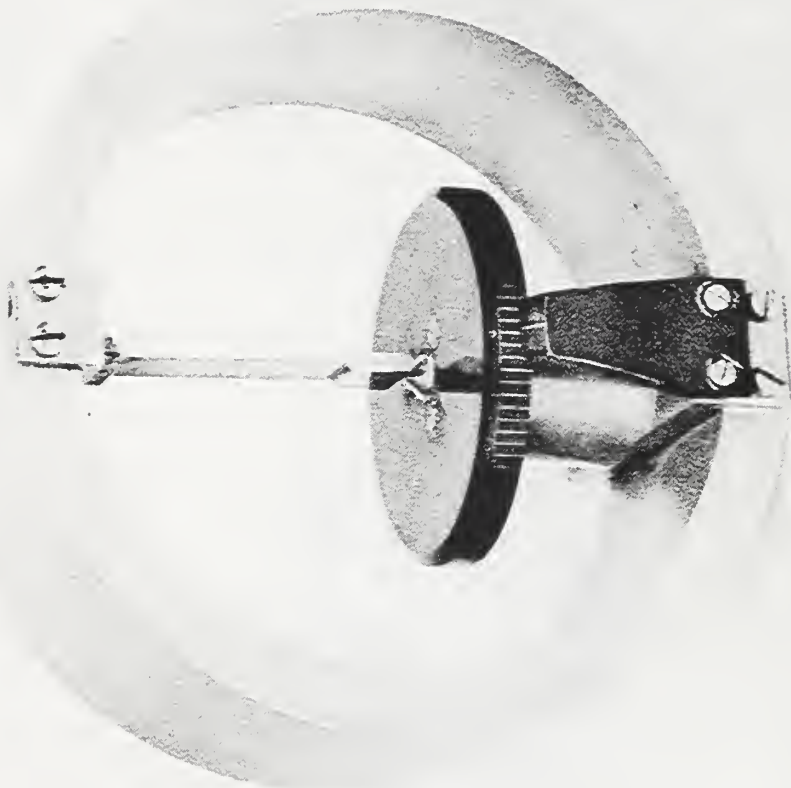

Proving Ring (1925) M504

AREA 19
Ampere 

When a year-long series of 20 experiments on the atomic weight of hydrogen indicated a value of 1.00819 as compared with the 1.00762 reported by Morley in 1895, W. A. Noyes refined his techniques and embarked on four more series of experiments in which he weighed the amount of water formed from a weighed amount of hydrogen and/or oxygen. The latter came from highly purified copper oxide that he prepared. Noyes used palladium to catalytically purify his hydrogen and also took advantage of its unique adsorptive property for hydrogen. Palladium was saturated with hydrogen at room temperature and weighed, then heated to release hydrogen and reweighed to give the amount used in the experiment. Weighing was done on the Ruprecht balance (M291) shown elsewhere in the Museum. The exhibit (M9) shows the actual palladium used - 360 g of 0.05 mm foil that released 2 g of hydrogen for each experiment. From five series of experiments Noyes obtained a value of 1.00787 differing from Morley by 15 parts in 100,000. The presently accepted value is 1.00797.

References

Noyes, W. A., The atomic weight of hydrogen, J. Am. Chem. Soc. 29, 1718 (1907).



Atomic Weight of Hydrogen (1907) M9

When in 1934 Harold C. Urey was awarded the Willard Gibbs Medal (and later the Nobel Prize) for his work on the isotopes of hydrogen, he acknowledged the help of "his young friend, Dr. F. G. Brickwedde of the Bureau of Standards" who supplied the gas distilled from liquid hydrogen. In 1931 Urey had "calculated the difference in electrode potentials of H^1 and H^2 with a view to separating the isotopes by an electrolytic method, but no separation seemed possible." E. W. Washburn and E. R. Smith (at NBS) did not calculate but experimented instead, and found that a very appreciable separation did occur in electrolytic processes. The experiment which started at NBS on December 9, 1931 electrolyzed normal water between platinum electrodes, condensed the evolved gases and continued until 98 percent of the original sample had been decomposed. The residual water in the ampoule displayed here has a specific gravity of 1.000164.

References

- Washburn, E. W., Smith, E. R., and Frandsen, M., The isotopic fractionation of water, Nat. Bur. Stand. (U.S.), J. Res. 11, 453, RP601 (1933).
- Urey, H. C., Significance of hydrogen isotopes, Ind. Eng. Chem. 26, 803 (1934).

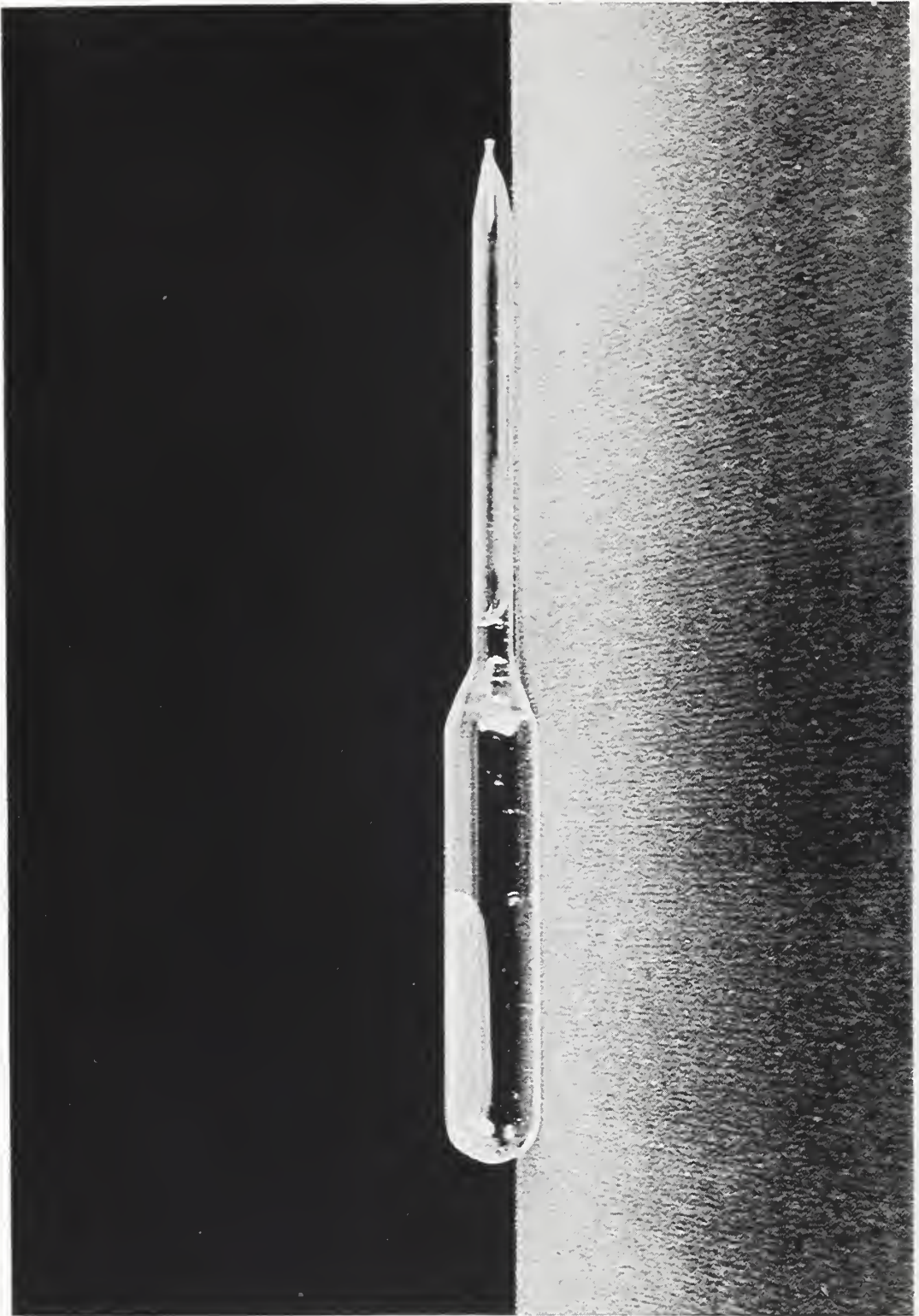

Heavy Water (1931) MII

This cyclotron resonance device which accelerates positive hydrogen ions (protons) was used for a determination of the value of the faraday, previously determined by electrochemical methods. The relation is $F = A\gamma_p(\omega_c/\omega_n)$ where A is isotopic weight and γ_p the gyromagnetic ratio of the proton, ω_c is the cyclotron resonance frequency, and ω_n is the nuclear resonance frequency.

In operation, the glass envelope is evacuated except for a trace of hydrogen, and its lower end is placed in a strong magnetic field. Electrons produced from a tungsten filament are accelerated into the box-like space surrounded by the stack of rectangular guard rings, where they create ions by impact. A small r-f voltage applied between the top and bottom of the space accelerates these ions in expanding spirals, provided the r-f frequency is the same as ω_c . The resonant ions are collected at the top of the guard-ring space, and the current to this collector gives the indication of resonance.

References

- Sommer, H. and Hipple, J. A., The Faraday and the Omegatron, Nat. Bur. Stand. (U.S.), Circ. 524, p. 21 (1953).

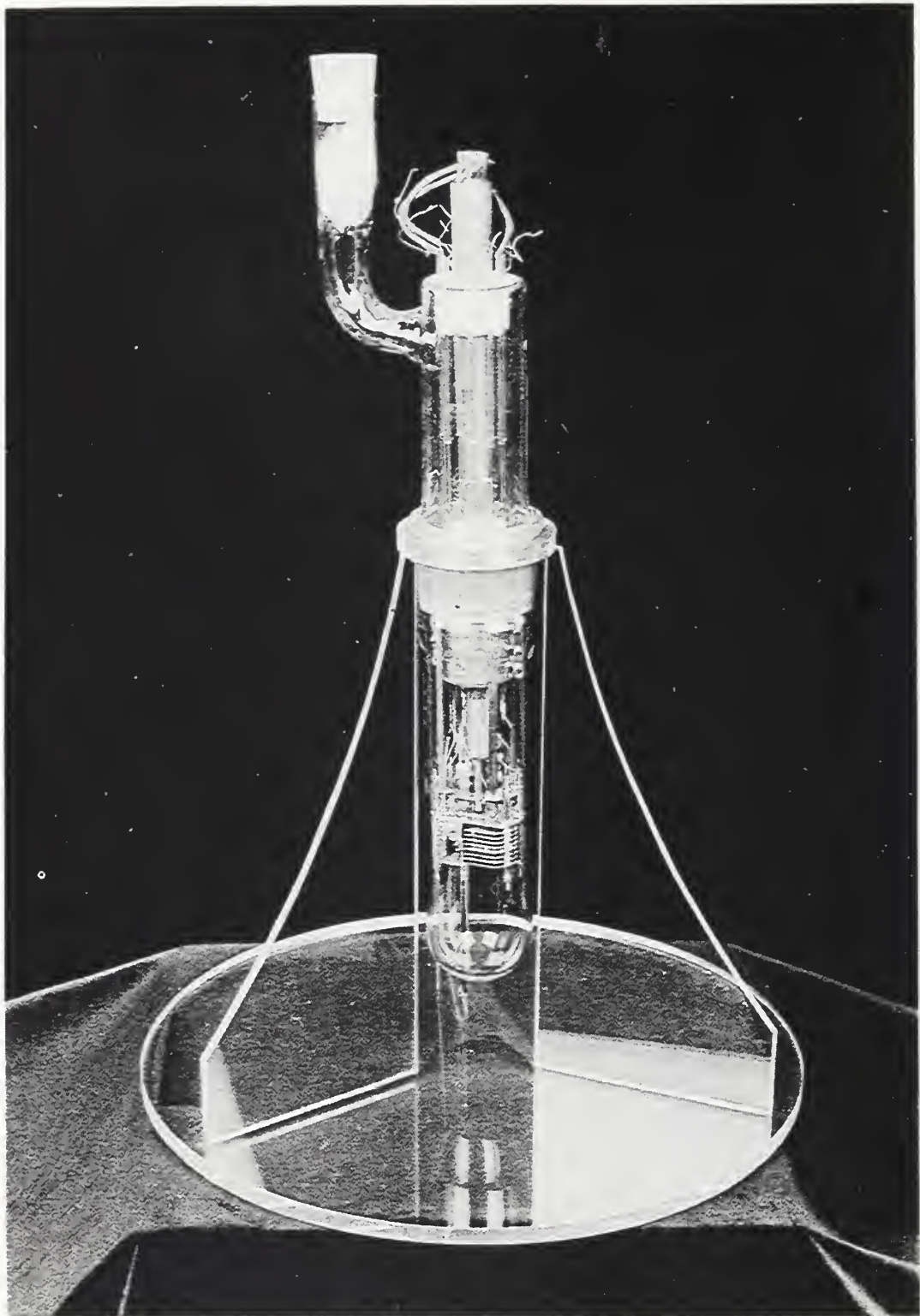

Omegatron (1951) M7

Weighing a current in apparatus of the Rayleigh type calls for measuring the force exerted on a moving coil suspended in the magnetic field supplied by a pair of fixed coils. Two important parameters are the local acceleration due to gravity, and the ratio of effective diameters of the moving and fixed coils. In this display, the aluminum and plexiglass mounts were used to hold the coils for measurement of this ratio by adjusting currents to produce equal magnetic fields at the center.

The coils of round copper wire or (later) flat aluminum ribbon are completely enclosed in build-up aluminum forms, 2 cm × 2 cm × 50 cm diameter for a fixed coil, and 1 cm × 1 cm × 25 cm diameter for the moving coil. For weighing the current, two of the larger coils were rigidly mounted about 20 cm apart, on a vertical axis. The moving coil was hung from one pan of a precision balance, which must be sensitive to the change of only a few grams, occurring when the current in the coils is reversed.

In the classic experiment of Rosa, Dorsey, and Miller, 1906-1910, a series of nearly 500 measurements determined the absolute ampere to be slightly larger (4 parts in 100,000) than the international ampere determined by silver voltameters (M170, M171). Multilayer windings were used in both the fixed and the moving coils. A redetermination in 1934 indicated the need for improved windings, and in 1939 two new moving coils were made. One was wound as a single-layer helix with 41 turns of copper wire of 0.51 mm diameter, the other as a flat compact spiral of 45 turns of aluminum ribbon 0.072 mm thick. The fixed coils were spirals with 125 layers of 0.104 mm aluminum ribbon. The weighted mean of these experiments gave 1 NBS international ampere = 0.999 86 absolute ampere. Another approach in 1940-1942 to the problem of measuring effective coil diameters used a subdivided helix of 27.516 54 cm axial length which served as the two fixed coils. That work was one of the major contributions from which the International Committee on Weights and Measures assigned the value effective January 1, 1948 of 1 NBS international ampere = 0.999 85 absolute ampere.

References

- Rosa, E. B., Dorsey, N. E., and Miller, J. M., A Determination of the International Ampere in Absolute Measure, Bull. Nat. Bur. Stand. 8, 269, S171 (1912).
- Curtis, H. L., Curtis, R. W., and Critchfield, C. L., An absolute determination of the ampere using improved coils, Nat. Bur. Stand. (U.S.), J. Res. 22, 485, RP1200 (1939).

Curtis, H. L., Driscoll, R. L., and Critchfield, C. L., An absolute determination of the ampere using helical and spiral coils, Nat. Bur. Stand. (U.S.), J. Res. 28, 133, RP1449 (1942).

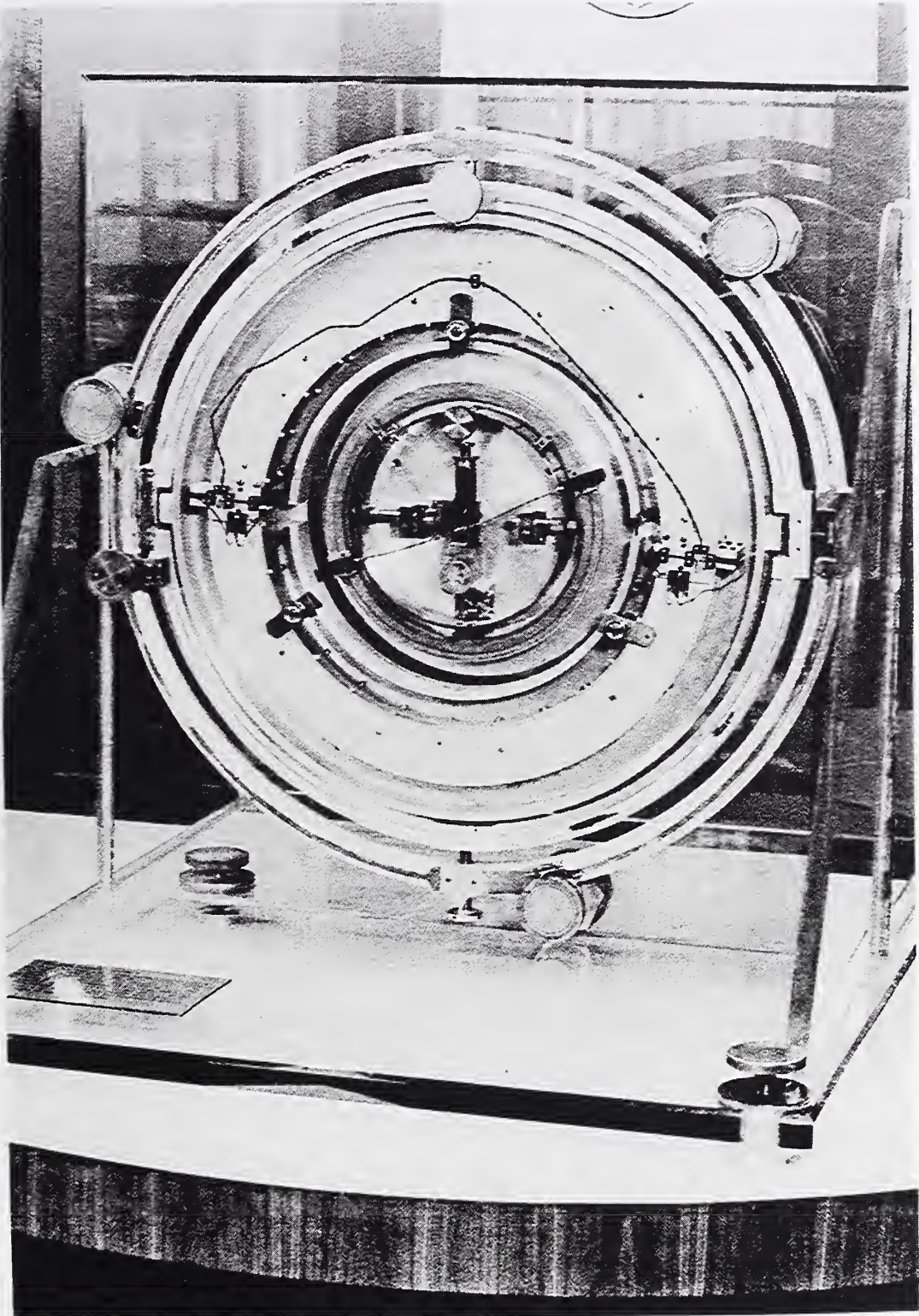

Coils, Rayleigh Current Balance (1906 - 1942) M69



This precision equal-arm two-pan balance, constructed about 1901 by A. Rueprecht & Sohn of Vienna, was purchased by NBS in 1945 from the Case School of Applied Science, and used for calibrating secondary kilogram standards against National Prototype No. 20. It was retired about 1960, with the advent of good Swiss one-pan balances with only two knife-edges, and with design improvements in counterweight location and arrestment mechanism which resulted from lengthy experiments by the NBS Mass Laboratory. Copies of the new NBS design are being used at the International Bureau in Sèvres, and are being purchased by the national laboratories of Sweden and Italy.

The 30-cm Rueprecht beam has a truss form, and carries a hardened steel knife-edge which rests on an agate flat. At the ends of the arms are knife-edges set a few micrometres below the central one, and parallel to it. On each of these rests crosswise a short knife (Thiesen compensator) from which hangs down a two-piece link supporting a weight pan; this construction lessens the effect of off-center loading. The whole instrument is encased in glass to lessen the effects of temperature and humidity changes on the buoyancy of air. All operations can be accomplished from a distance by means of long control rods.

To compare a secondary standard mass with the Prototype Kilogram, each was placed on one of the cork-covered cut-out platforms at the base, and the case was closed. Using the control rods, the operator raised the cork-covered cruciform member, swung it over above the cut-out weight pans, and lowered the weights onto the pans. The arrested beam was released, allowed to oscillate, and its rest position noted. To improve the sensitivity, the operation was repeated after the weights were lifted off the pans, returned to the central platforms, and transposed to the opposite pans.

Then, using the small sensitivity weights of 120 to 126 mg selected from the top of the case, the comparison was repeated to evaluate the mass which was equivalent to the change in the scale observation when the major weights being compared were interchanged. Any difference between the major weights could be estimated to a fraction of a milligram.

References

- Pontius, P. E., Mass and Mass Standards, Nat. Bur. Stand. (U.S.), Monogr. 133 (1974).
- Bowman, H. A. and Almer, H. E., Minimization of the arrestment error in one-pan, two-knife balance systems, Nat. Bur. Stand. (U.S.), J. Res. 67C (Eng. and Instr.), No. 3 (July-Sept. 1963).

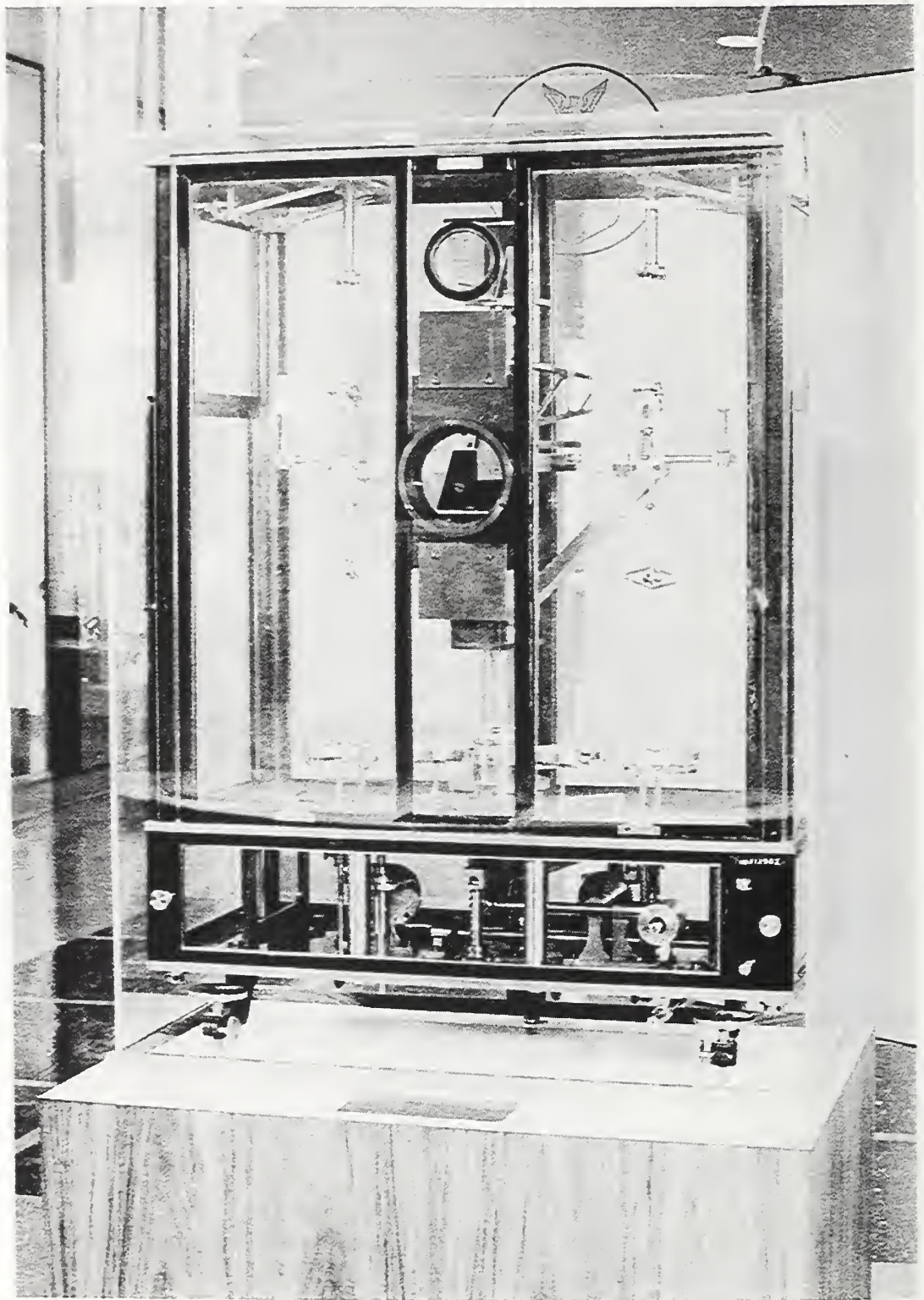

Rueprecht Balance (1901) M291

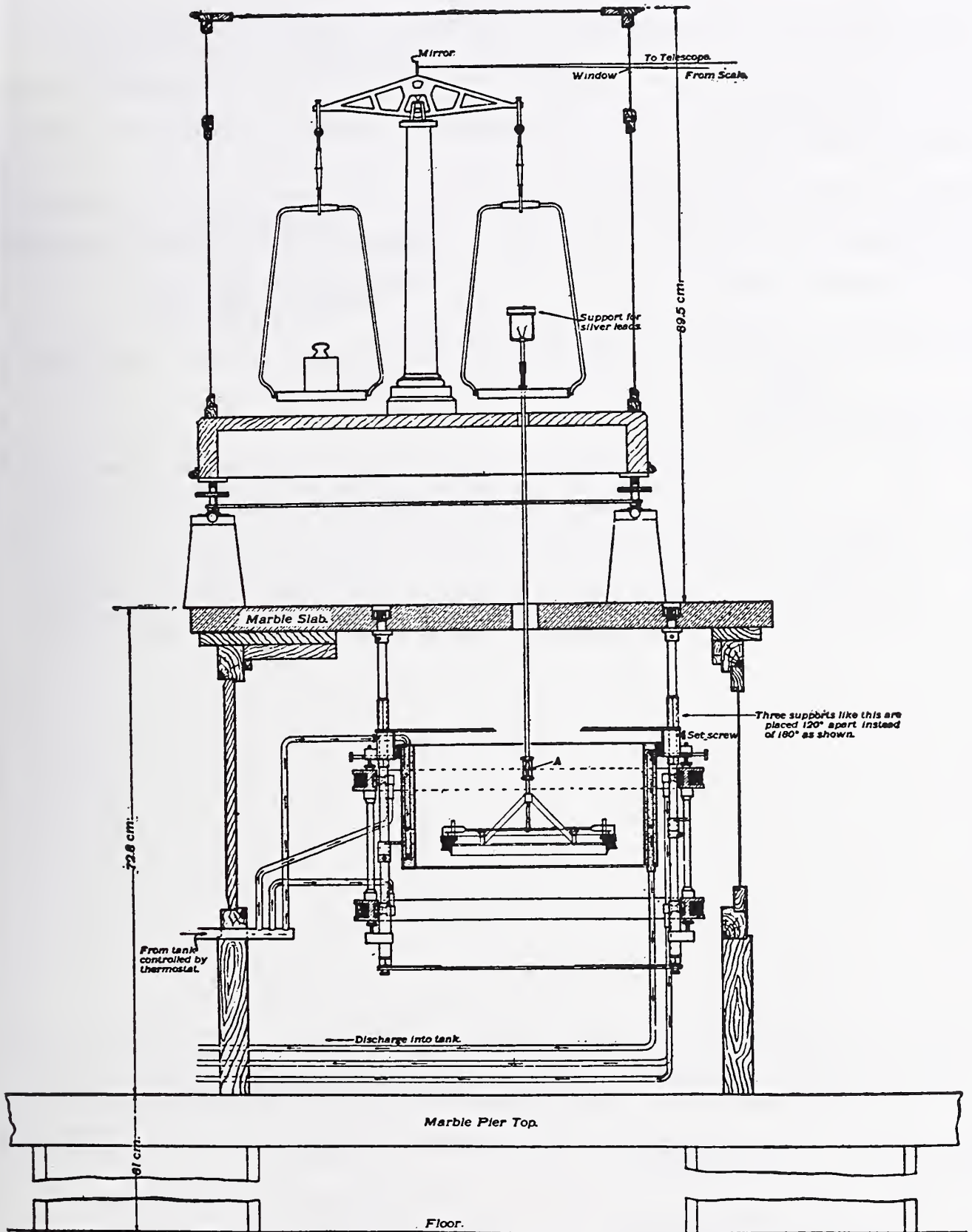

Rueprecht Balance (1901) M291
 Schematic drawing of section of the assembled balance

U.S. DEPT. OF COMM. BIBLIOGRAPHIC DATA SHEET	1. PUBLICATION OR REPORT NO. NBSIR 76-1125	2. Gov't Accession No.	3. Recipient's Accession No.	
4. TITLE AND SUBTITLE Catalog of Artifacts on Display in the NBS Museum		5. Publication Date November 1977	6. Performing Organization Code	
7. AUTHOR(S) H.L. Mason, Editor		8. Performing Organ. Report No.		
9. PERFORMING ORGANIZATION NAME AND ADDRESS NATIONAL BUREAU OF STANDARDS DEPARTMENT OF COMMERCE WASHINGTON, D.C. 20234		10. Project/Task/Work Unit No.	11. Contract/Grant No.	
12. Sponsoring Organization Name and Complete Address (Street, City, State, ZIP) Same as 9		13. Type of Report & Period Covered Interim	14. Sponsoring Agency Code	
15. SUPPLEMENTARY NOTES Artifacts currently on display may be replaced or rearranged periodically. The Catalog will be amended accordingly to keep it current.				
16. ABSTRACT (A 200-word or less factual summary of most significant information. If document includes a significant bibliography or literature survey, mention it here.) Apparatus and other memorabilia illustrative of the scientific and engineering achievements of NBS are described, with statements of their technical function and their historic place in the evolution of physical measurement.				
17. KEY WORDS (six to twelve entries; alphabetical order; capitalize only the first letter of the first key word unless a proper name; separated by semicolons) History of science; measurement instruments; measurement standards; National Bureau of Standards; National measurement standards; physical measurement; weights and measures.				
18. AVAILABILITY <input checked="" type="checkbox"/> Unlimited <input type="checkbox"/> For Official Distribution. Do Not Release to NTIS <input type="checkbox"/> Order From Sup. of Doc., U.S. Government Printing Office Washington, D.C. 20402, SD Cat. No. C13 <input checked="" type="checkbox"/> Order From National Technical Information Service (NTIS) Springfield, Virginia 22151	19. SECURITY CLASS (THIS REPORT) UNCLASSIFIED	21. NO. OF PAGES 290	20. SECURITY CLASS (THIS PAGE) UNCLASSIFIED	22. Price \$11.00

