

NBSIR 75-758 (R)

Operational Manual for Microwave Hygrometer Model III

Daniel P. Stokesberry

Product Engineering Division
Institute for Applied Technology
National Bureau of Standards

and

Saburo Hasegawa

Heat Division
Institute for Basic Standards
National Bureau of Standards

July 1975

Final Report

Prepared for
Naval Air Systems Command
Department of the Navy
Washington, D. C. 20360

NBS 75-758

OPERATIONAL MANUAL FOR MICROWAVE HYGROMETER MODEL III

Daniel P. Stokesberry

Product Engineering Division
Institute for Applied Technology
National Bureau of Standards

and

Saburo Hasegawa

Heat Division
Institute for Basic Standards
National Bureau of Standards

July 1975

Final Report

Prepared for
Naval Air Systems Command
Department of the Navy
Washington, D. C. 20360



U.S. DEPARTMENT OF COMMERCE, Rogers C.B. Morton, *Secretary*
James A. Baker, III, *Under Secretary*
Dr. Betsy Ancker-Johnson, *Assistant Secretary for Science and Technology*
NATIONAL BUREAU OF STANDARDS, Ernest Ambler, *Acting Director*

Table of Contents

	Page
1. General	1
2. Cavity	3
3. Frequency Lock Circuitry	3
4. Temperature Control Circuitry	4
5. Operation	6
5.1 Temperature Controls	6
5.2 Cavity Drying	6
5.3 Zero Reading	7
5.4 Sample Gas Measurements	7
5.5 Summary of Operating Procedure	8
6. Calibration	10
6.1 Dew Point Calibration	10
6.2 Vapor Pressure Calibration	11

List of Figures

- Figure 1 Flow diagram
- Figure 2 Block diagram of the measurement circuitry
- Figure 3 Block diagram of the lock circuit
- Figure 4 Schematic Lock Loops
- Figure 5 Block diagram temperature control circuit
- Figure 6 Schematic diagram temperature control circuit
- Figure 7 Schematic diagram zero crossing detector
- Figure 8 Front compartment
- Figure 9 Exterior view
- Figure 10 Interior view of the oven compartment
- Figure 11 Wiring diagram

List of Tables

- Table 1 Delta R vs dew/frost point
- Table 2 Delta R vs vapor pressure

Wiring List

Output Connector Pin Assignments ..

Abstract

This is an operational manual for the NBS microwave hygrometer, Model III. It covers the design, operation and performance of the hygrometer. It is capable of measuring water vapor equivalent to the dew/frost point range of 40°C to -53°C .

When compared with the NBS two-pressure humidity generator over the dew/frost point range of 40°C to -53°C , the following estimates of the one sigma random errors were obtained:

- a) 0.02°C for dew points 40°C to 20°C
- b) 0.03°C " " " 20°C to 0°C
- c) 0.09°C " frost points 0°C to -27°C
- d) 0.60°C " " " -27°C to -53°C

1. General

The hygrometer contains two microwave cavities. The resonance frequency of each cavity is determined by its dimensions and geometry, and environmental factors including temperature, pressure, and the refractive index of the medium. Sample air is drawn through the instrument in such a manner that the air within each cavity is at the same total pressure and temperature; however, one cavity is exposed to the moist test air and the other is exposed to the same air sample with all the water vapor removed. Under these conditions the resonance frequency of the sample cavity (moist air) differs from that of the reference cavity (dry air) by an amount proportional to the water vapor content of the sample air.

Each cavity is maintained at the same constant temperature to insure dimensional stability and the gas in each is also maintained at the same constant temperature and equal pressure through the technique illustrated in Figure 1. The sample air heater raises the temperature of the air to 59.9°C . The air then flows through a coiled stainless steel tubing which brings it up to the oven and cavity temperature of $60^{\circ} \pm .03^{\circ}\text{C}$ and through the sample cavity. Most of the air exits the sample cavity directly through the vacuum pump. A small part of the air flows through a dryer and then into the reference cavity before exiting the system through the vacuum pump.

The equation for the refractive index, n , of moist air for a fixed temperature, Essen and Froome¹ and Smith and Weintraub², can be expressed in the form:

$$(n-1) 10^6 = AP_1 + BP_2 + CP_3,$$

where P_1 = partial pressure of dry air,

P_2 = partial pressure of carbon dioxide,

P_3 = partial pressure of water vapor, and

A, B, and C = constants.

¹Essen, L. and K. D. Froome, The Refractive Indices and Dielectric Constants of Air and its Principal Constituents at 24,000 MC/S, Proc. Phys. Soc., B64 862 (1951).

²Smith, E. K. Jr., and S. Weintraub, The Constants in Equation for Atmospheric Refractive Index at Radio Frequencies, J. Res. NBS 50, 39 (1953) RP2385.

For the case of two identical microwave cavities filled with air at the same total pressure, temperature and partial pressure of carbon dioxide, and using the relationship $n = f_0/f$, the difference in frequency between the two cavities is:

$$\Delta f \frac{f_0}{f_r f_s} = K P_3,$$

where Δf = resonance frequency of the reference cavity minus the resonance frequency of the sample cavity,

f_0 = resonance frequency of the cavity under vacuum,

f_r = resonance frequency of the reference cavity,

f_s = resonance frequency of the sample cavity, and

K = constant.

The following approximation (good to better than 0.1%) can be made for the range of frequency used:

$$\frac{\Delta f}{f_0} \approx \Delta f \frac{f_0}{f_r f_s} = K P_3.$$

Therefore, a shift in the resonance frequency of the sample cavity is proportional to the water vapor content of the sample air.

The major change in the new instrument, Model III, compared to Model II³ is the modification of the basic measurement method to eliminate components which are subject to mechanical wear or sensitive to mechanical shock or vibration. The new measurement method requires no moving parts and consists of electronic circuitry which directly measures the frequency difference between the two cavities.

A block diagram of the electronic circuit is shown in Figure 2. Each microwave cavity is fed by a separate microwave oscillator. The frequency of each oscillator is controlled by a lock circuit which forces the oscillator to stay at the resonance frequency of the cavity. The outputs of the two oscillators are fed to a microwave mixer. The frequency of the mixer output is equal to the difference in frequency between its two inputs. This signal is fed to a counter which displays the frequency difference between the two cavities.

³Hasegawa, S. and D. P. Stokesberry, An Automatic Digital Microwave Hygrometer, Rev. Sci. Instrum. 46, 867 (July 1975).

2. Cavity

The two cylindrical cavities are milled into a single block of invar (107.95mm x 63.50mm x 65.84mm). Each cavity is capped by stainless steel endplates which are designed to temperature compensate the cavity; this reduces the change in resonance frequency due to a change in temperature. Air inlet and outlet ports are milled into the endplates. The physical dimensions of the cavities are chosen so that each cavity will resonate in the TE₀₁₂ mode at 10.7 GHz with a Q of 10,000 and an insertion loss of about 8 dB. The cavities are sealed, quartz windows provide coupling into and out of the cavities. The isolators buffer the cavities from its electrical environment. Video detector diodes are mounted at the electrical outlet port of each cavity.

3. Frequency Lock Circuitry

A block diagram of one of the lock circuits is shown in Figure 3. The operation of the loop can be understood by opening the two feedback loops, i.e., by breaking both the connection between the second dc amplifier and the power supply and the connection between the first dc amplifier and the summing network. The frequency of the microwave oscillator is controlled by the voltage of the power supply and by the voltage from the summing network into its modulation port. When the loops are open, the oscillator is "free running"; its frequency can be adjusted by turning a mechanical tuning screw so that it is close to the resonance frequency of the cavity. A small ac signal from the local oscillator is fed through the summing network to the microwave oscillator. This causes frequency modulation of the microwave signal. The microwave cavity acts as a discriminator; it changes the fm signal into an amplitude modulated signal. The video detector senses the amplitude modulation of the microwave signal. The signal at its output is composed of a combination of a 200 kHz sinewave and the harmonics of this frequency. This signal is amplified by a narrow-band ac amplifier which rejects the harmonics. The amplified signal is fed into a phase sensitive detector. The reference phase information for the phase sensitive detector is obtained from the local oscillator. The output of the phase sensitive detector is a dc voltage which is positive if the frequency of the source is less than the resonance frequency of the cavity and negative if the source frequency is greater than the resonance frequency of the cavity. When the primary loop is closed, this output forces the frequency of the source in the direction which minimizes the difference between the source frequency and the cavity resonance frequency.

The secondary lock loop acts in the same manner as the primary lock loop. The output of the dc amplifier is fed into the remote sensing terminals of the power supply. This causes a change in the output voltage of the supply. The frequency of

the microwave source is sensitive to the power supply voltage and thus the loop acts to minimize the difference between the source frequency and the microwave cavity frequency. This loop greatly increases the locking range of the instrument and effectively increases the lock accuracy by adding more gain to the loop. A much slower time constant, on the order of two seconds, is incorporated into the secondary loop to insure that the two loops will be stable.

A schematic diagram of the lock loops is shown in Figure 4. The local oscillator is common to both lock circuits. Each microwave oscillator has a low frequency output port whose signal frequency is one seventh that of its high frequency output. The two low frequency outputs are fed into a balanced mixer circuit. The frequency of the output signal from the mixer is equal to the difference in frequency between its two inputs. This signal is fed directly to a commercial frequency counter. The least significant digit of the counter represents a 10 Hz signal. Thus each count on the counter signifies a frequency difference of 70 Hz.

4. Temperature Control Circuitry

The microwave hygrometer contains three oven control circuits and one temperature monitor circuit. Each temperature control consists of a coil of nichrome wire and electronic circuitry which controls the amount of time which ac line voltage is applied across the coil of wire. The circuits are zero-crossing proportional temperature controls. When the oven temperature is far below the setpoint temperature, the heater is turned on all the time. As the oven temperature approaches the setpoint, the heater is turned on for a proportionately smaller part of the time and if the oven temperature exceeds the setpoint by some amount, the heater is turned off all the time. The power input to each heater is chosen so that the heater will be on about half the time when the oven is at the setpoint temperature. The circuitry will turn the heater on and off only at the zero crossing points of the ac line voltage. This minimizes the electrical noise generated by the heaters. The circuits each consist of a thermistor bridge circuit whose output is proportional to the difference between the temperature of the thermistor and a setpoint temperature. The setpoint is controlled by a variable resistor in one leg of the bridge. A block diagram of one of the temperature control circuits is shown in Figure 5. The output of the bridge circuit is buffered and amplified by a dc amplifier and fed to one side of a comparator. This signal is a large positive voltage if the oven temperature is below the setpoint and a large negative voltage if the oven temperature is above the setpoint. As the oven temperature approaches the setpoint, the signal will be in the range between zero and minus one volt. This is the proportional

region of the controller. The other input to the comparator is a negative-going ramp voltage which starts at zero and falls linearly to minus one volt in about 200 ms. It then returns rapidly to zero. The output of the comparator is open circuited whenever the ramp voltage is more positive than the buffered signal from the thermistor bridge and it is a low impedance path to ground whenever the signal from the bridge is more positive than the ramp voltage.

The output of the comparator is one input to the opto-isolator. An open circuit turns off the opto-isolator and a ground turns it on. Thus, when the oven is much colder than the setpoint, the opto-isolator is turned on all the time and when the oven is much warmer than the setpoint the opto-isolator is turned off all the time. When the temperature of the oven approaches the setpoint, the opto-isolator is turned on for that portion of the time when the signal from the thermistor bridge is more negative than the ramp voltage. The other input to the opto-isolator is a pulse from the zero crossing detector. The input to this circuit is a 60 Hz sinewave which is in phase with the line. This signal is full-wave rectified and sent to a circuit which puts out a +15 volt pulse whenever the ac line approaches a zero crossing; a pulse occurs for each half period of the 60 Hz sinewave. The output of the opto-isolator is a pulse, synchronized with the zero crossings of the ac line, which occurs whenever the signal from thermistor bridge is more positive than the ramp voltage. Each pulse turns on a triac for one half period of the line voltage. When the triac is turned on, current flows through a heater element in the oven.

A schematic diagram of the temperature control circuits for the inner oven, outer oven and sample air heater is shown in Figure 6. A schematic diagram of the zero crossing detector, ramp generator and temperature monitor is shown in Figure 7. The temperature monitor circuit is identical to the front end of a temperature control circuit, but the output of the buffer amplifier is fed to a zero-center microammeter. One division of the meter corresponds to approximately 0.06°C . This meter indicates when the inner oven temperature has reached the setpoint.

5. Operation

Before the hygrometer is in an operative condition, the cavities must be in temperature equilibrium and the REFERENCE CAVITY must be dry.

5.1 Temperature Controls

It takes approximately 6 to 8 hours for the cavities to reach a temperature equilibrium of 60°C . The TEMPERATURE MONITOR METER, Figure 8, indicates the cavity air bath temperature (inner oven temperature). The meter is set so that the center position (0 reading) corresponds to a temperature of 60°C . The inner oven temperature controls should maintain a temperature of $60^{\circ} \pm .03^{\circ}\text{C}$ which corresponds to approximately $\pm 1/2$ division from the setpoint on the TEMPERATURE MONITOR METER.

Step (1). Turn on power switch and set second switch to "Standby" position, Figure 9. These switches turn on the inner oven heater, outer oven heater, and blowers. In the "Standby" position the vacuum pump and the sample air preheater are off.

5.2 Cavity Drying

It takes approximately 30 minutes to dry the cavities.

- Step (1). a). Lay one layer of Teflon filter in the bottom of the dryer jar.
- b). Fill the SAMPLE AIR DRYER with 2 pounds of indicating CaSO_4 (Drierite) and add 1/2 pound of anhydrous $\text{Mg}(\text{ClO}_4)_2$ on top of the CaSO_4 .
- c). Lay one layer of Teflon filter on top of the $\text{Mg}(\text{ClO}_4)_2$.
- d). Fill 1/2 of the REFERENCE CAVITY DRYER U TUBE with CaSO_4 and 1/2 with $\text{Mg}(\text{ClO}_4)_2$.
- e). Connect the SAMPLE AIR DRYER to the INLET VALVE.
- f). Connect the CaSO_4 side of the REFERENCE CAVITY DRYER to the REFERENCE CAVITY FLOW RESTRICTOR line and the $\text{Mg}(\text{ClO}_4)_2$ side to the line labeled REF.
- Step (2). Open the INLET VALVE and the inlet to the SAMPLE AIR DRYER (rubber stopper).
- Step (3). Open full (approximately 9 revolutions counterclockwise) the REFERENCE CAVITY FLOW RESTRICTOR valve (micrometer valve).

Step (4). Turn the switch from "Standby" position to "Operate" position.

Step (5). Adjust the FLOW CONTROL VALVE (needle valve) located in the VACUUM PUMP line so that the CAVITY PRESSURE GAGE reads -1.3.

Renew the dessicants in the dryer when 3/4 of the indicating CaSO turns pink.

5.3 Zero Reading

After the cavities are in temperature equilibrium and dry, the reading on the COUNTER should be constant to ± 1 count over a period of 15 minutes. The ZERO READING is the reading on the COUNTER when both cavities are dry. The ZERO READING must be subtracted from all subsequent readings (readings taken with moist air in the sample cavity).

ZERO READING should be taken at the beginning and the end of each day of operation.

After taking the ZERO READING:

Step (1). Put switch in "Standby" position.

Step (2). Remove the SAMPLE AIR DRYER and seal the dryer with rubber stoppers.

Step (3). Close the REFERENCE CAVITY FLOW RESTRICTOR valve and then open the RESTRICTOR 7 revolutions counterclockwise.

5.4 Sample Gas Measurements

The sample gas measurements are made after completing the operations outlined in Paragraphs 5.1, 5.2, and 5.3. Before proceeding to Step (1) check to see that: the INLET VALVE is open and the REFERENCE CAVITY FLOW RESTRICTOR is adjusted to 7 revolutions open from the closed position.

Step (1). Connect the sample air line to the INLET VALVE. The sample air line should be 1/2" diameter tubing to minimize the pressure drop in the line.

Step (2) Connect the AIR FILTER to the inlet of the sample air line.

Step (3). Put switch in "Operate" position which turns on the VACUUM PUMP and adjust the FLOW CONTROLLER

VALVE so that the CAVITY PRESSURE GAGE reads -1.3. The nominal flow is now adjusted for 10 lpm sample air and 0.1 lpm dry air through the REFERENCE CAVITY.

After the TEMPERATURE MONITOR METER reading and the COUNTER reading stabilize, subtract the ZERO reading from the COUNTER reading. This value is the DELTA R listed in column 1 of Table 1. Linear interpolation between the values listed in Table 1 is better than $\pm .01$ C for Delta R between 37000 and 45 and ± 0.1 C for Delta R between 45 and 15.

5.5 Summary of Operating Procedure

- Step (1). Turn the second switch to "Standby" position.
- Step (2). Turn on the Power switch.
- Step (3). Connect the SAMPLE AIR DRYER to the sample air line.
- Step (4). Connect the REFERENCE CAVITY DRYER.
- Step (5). Open the SAMPLE AIR INLET valve after the cavities reach temperature equilibrium (60°C) and open SAMPLE AIR DRYER inlet (remove rubber stopper).
- Step (6). Open full (turn counterclockwise approximately 9 revolutions from closed position) the REFERENCE CAVITY FLOW RESTRICTOR valve (micrometer valve).
- Step (7). Switch to "Operate" position which turns on the VACUUM PUMP and PREHEATER.
- Step (8). Adjust the FLOW CONTROL valve (needle valve located upstream of the VACUUM PUMP) so that the CAVITY PRESSURE GAGE reads -1.3.
- Step (9). ZERO READING. After the TEMPERATURE MONITOR METER reads steady $\pm 1/2$ division from set-point (0 reading) and the COUNTER reading reaches a constant value (± 1 digit), record the COUNTER reading.
- Step (10). Turn switch to "Standby" position.
- Step (11). Disconnect the SAMPLE AIR DRYER.
- Step (12). Close the REFERENCE CAVITY FLOW RESTRICTOR valve and then open the RESTRICTOR valve 7 revolutions from the closed position.

- Step (13). Connect the sample air line (1/2" diameter tubing) to the INLET valve.
- Step (14). Connect the SAMPLE AIR FILTER to the inlet line.
- Step (15). Turn on the VACUUM PUMP by switching to "Operate" position.
- Step (16). Adjust the FLOW CONTROL valve so that the CAVITY PRESSURE GAGE reads -1.3.
- Step (17). Record the COUNTER reading after the TEMPERATURE MONITOR METER and the COUNTER readings reach stable values.
- Step (18). Subtract the ZERO reading (Step 9) from the COUNTER reading (Step 17). This reading is listed as DELTA R in Table 1.
- Step (19). Enter DELTA R in Table 1 and obtain the corresponding dew or frost point.
- Take ZERO READING after completion of tests.
- Step (20). Shut off the VACUUM PUMP by turning the switch to "Standby" position.
- Step (21). Disconnect the sample air line at the INLET valve and connect the SAMPLE AIR DRYER and open the inlet to the DRYER.
- Step (22). Open full the REFERENCE CAVITY FLOW RESTRICTOR valve.
- Step (23). Turn on the VACUUM PUMP by turning switch to "Operate" position.
- Step (24). Adjust the FLOW CONTROL valve so that the CAVITY PRESSURE GAGE reads -1.3. Take ZERO READING.
- Step (25). If the reading taken in Step (24) is different from the reading taken in Step (9) use the average of the two readings as the ZERO READING.
- Step (26). Turn switch to "Standby".
- Step (27). Shut off the INLET valve and the inlet to the SAMPLE AIR Dryer.
- Step (28). If the hygrometer is not going to be used within the next 3 or 4 days, turn off the power switch. If the hygrometer is going to be used within the next 3 or 4 days leave the power switch on and the second switch

on "Standby". Start from Step 5 when the run is resumed. Replace either or both air driers when 2/3 of the indicating CaSO_4 (Drierite) turns pink.

6. Calibration

The Microwave Hygrometer was calibrated against the NBS two-pressure humidity generator.^{4,5} Stability tests were performed by making a number of calibrations over a span of six months. The maximum uncertainty of the humidity generator is $\pm 0.1^\circ\text{C}$ for dew points 40°C to -30°C , $\pm 0.2^\circ\text{C}$ for dew points -30°C to -45°C and $\pm 0.5^\circ\text{C}$ for dew points -45°C to -55°C .

6.1 Dew Point Calibration

The following second order equations for dew-point temperatures as a function of Delta R (wet sample air reading minus dry sample air reading) were obtained by means of least squares regression fits to the data:

(a). For dew points (t) 40°C to 20°C ;

$$t = -32.660598 - 11.228511 X + 5.9287645 X^2$$

(b). For dew points (t) 20°C to 0°C ;

$$t = -51.998170 - 1.6250835 X + 4.7354931 X^2$$

(c). For dew points (t) 0°C to -20°C ;

$$t = -60.658552 + 2.7393976 X + 4.1946508 X^2$$

(d). For dew points (t) -20°C to -40°C ;

$$t = -71.327487 + 9.0693096 X + 3.2985550 X^2$$

(e). For frost points (t) 0°C to -27°C ;

$$t = -67.698365 + 10.861096 X + 2.4453468 X^2$$

4

Wexler, A. and R. D. Daniels, Jr., "Pressure Humidity Apparatus", J. Res. Nat'l. Bur. Std. 48, 269, (1952).

5

Wexler, A., "Calibration of Humidity Measuring Instruments at the Nat'l. Bur. Std.", Trans. ISA 7, (1968) p. 356.

(f). For frost points (t) -27°C to -53°C ;

$$t = -73.687587 + 15.784185 X + 1.4101825 X^2$$

where $X = \log_{10} \Delta R$.

ΔR = moist air reading minus dry air reading.

The results of the above equations are given in Table 1. Linear interpolation between the values listed in Table 1 is better than $\pm 0.01^{\circ}\text{C}$ for Delta R between 37000 and 45 and $\pm 0.1^{\circ}\text{C}$ for Delta R between 45 and 15.

As an estimate of the expected random error, the residual standard deviations were calculated for the differences between the calculated dew or frost points using the second order equations and the generated dew or frost points of the two pressure generator. The following estimates of the one sigma random error were obtained:

- a). 0.02°C for dew points 40°C to $+20^{\circ}\text{C}$
- b). 0.03°C for dew points 20°C to 0°C
- c). 0.06°C for dew points 0°C to -20°C
- d). 0.43°C for dew points -20°C to -40°C
- e). 0.09°C for frost points 0°C to -27°C
- f). 0.60°C for frost points -27°C to -53°C

6.2 Vapor Pressure Calibration

The following third order equation for vapor pressure (Pascal) as a function of Delta R (wet sample air reading minus dry sample air reading) was obtained by means of least squares regression fit to the data:

$$e \text{ (Pascal)} = -0.85096359 + 0.19764142 \Delta R - 0.56181361 \times 10^{-7} (\Delta R)^2 + 0.11756679 \times 10^{-11} (\Delta R)^3,$$

where Pascal X 0.01 = millibar.

The above equation is tabulated in Table 2.

Again as an estimate of the expected random error, the residual standard deviation was calculated for the differences between the calculated vapor pressure using the third order equation and the vapor pressure generated by the two pressure generator. For Delta R between 15 and 37000 the estimate of the one sigma random error was 2.25 Pa (.0225 mb). This value of

one sigma random error corresponds very closely to an uncertainty in the Delta R reading of ± 11 units.

To convert the vapor pressure given by the above third order equation to dew point temperature using the saturation vapor pressure tables by Goff⁶, the vapor pressure obtained by the third order equation must first be divided by either f_w or f_i given in Tables 89 and 90 by List⁷.

6

Goff, J. A., "Saturation Pressure of Water on the New Kelvin Scale", HUMIDITY AND MOISTURE 3, Arnold Wexler (ed), Reinhold Corp., N. Y., 1965 p. 289.

7

List, R. J., SMITHSONIAN METEOROLOGICAL TABLES, Smithsonian Institution, Washington, D. C. 1951, p. 340.

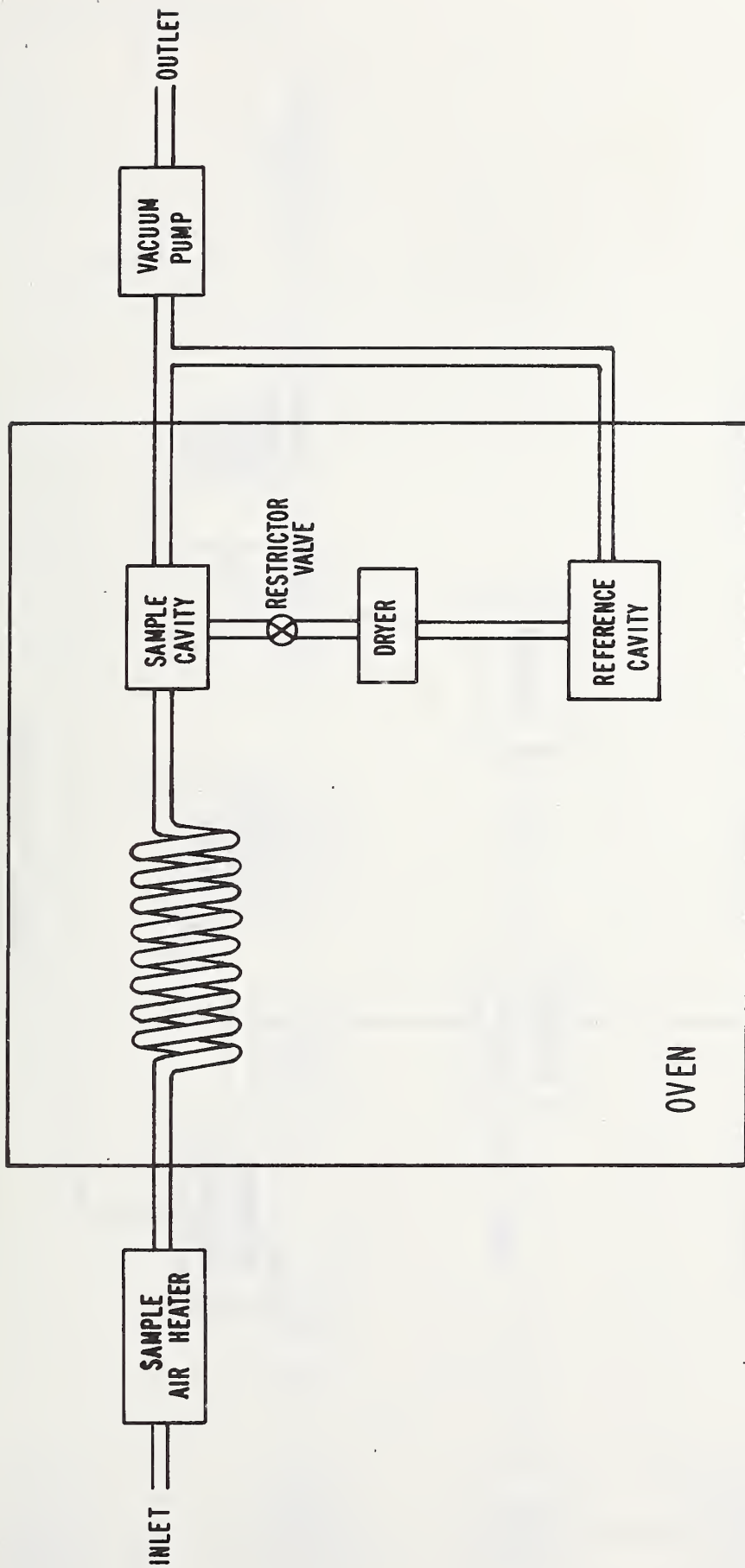

Figure 1 Block diagram of the air sampling system.

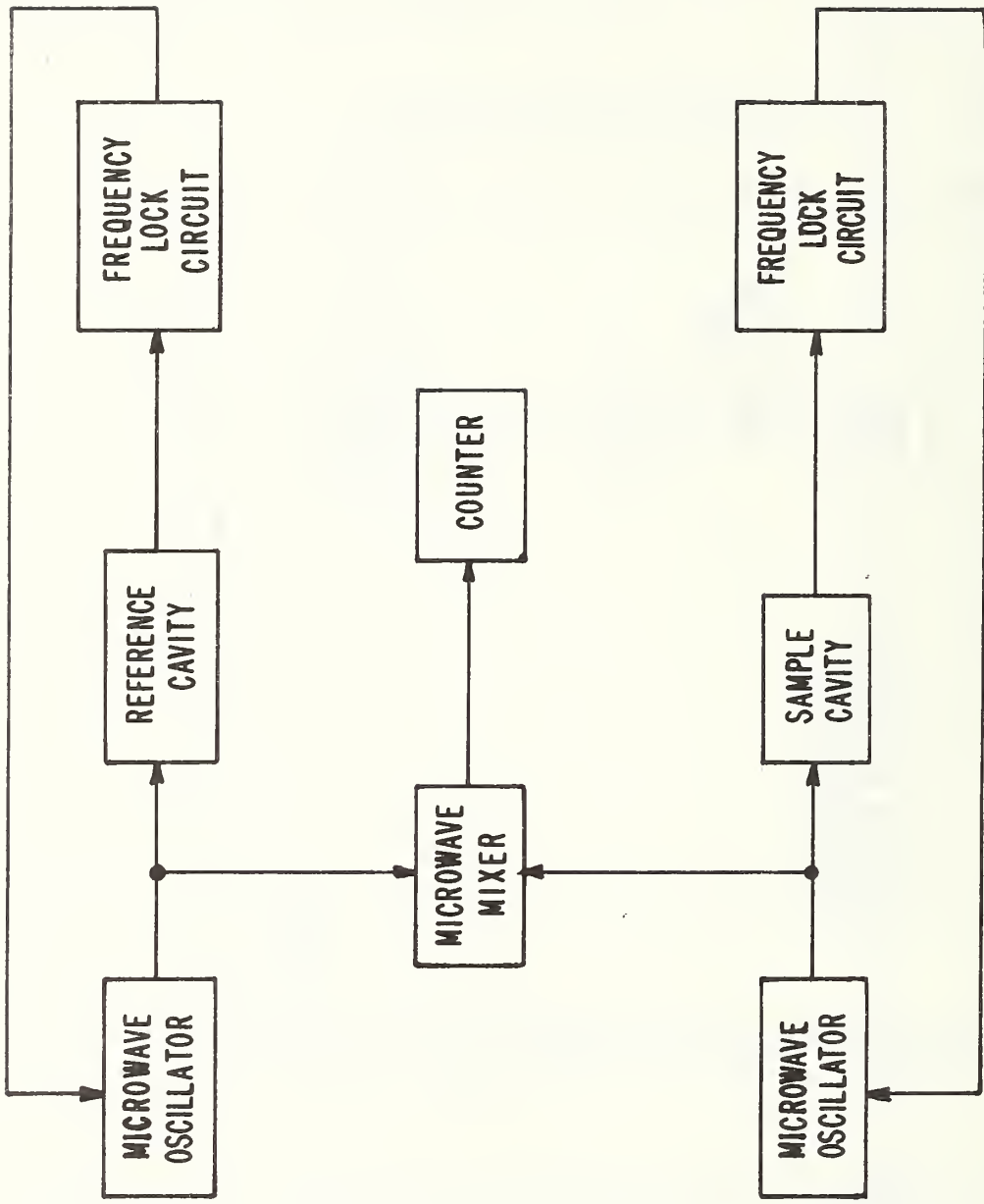

Figure 2. Block diagram of the measurement method used in Microwave Hygrometer Model III.

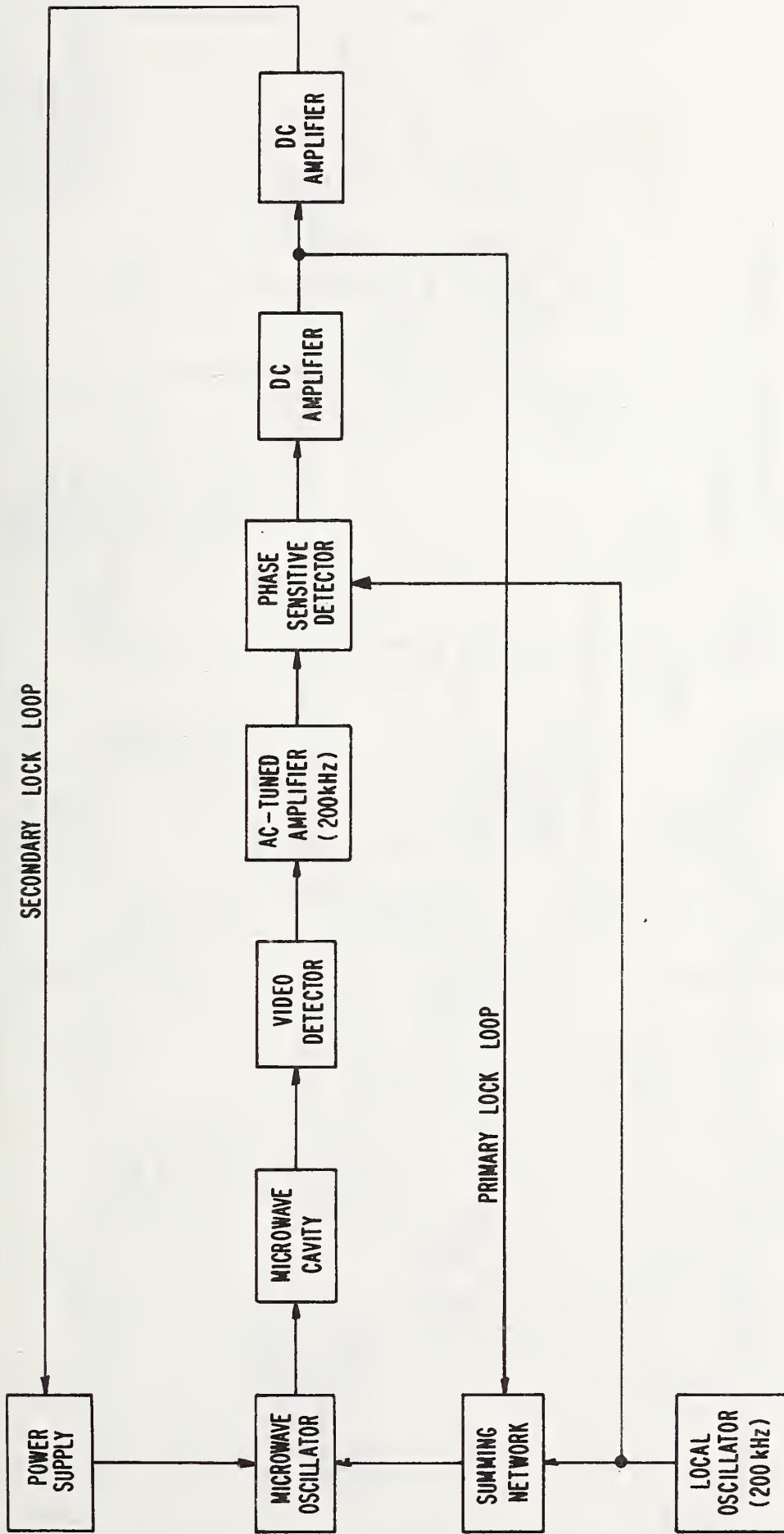
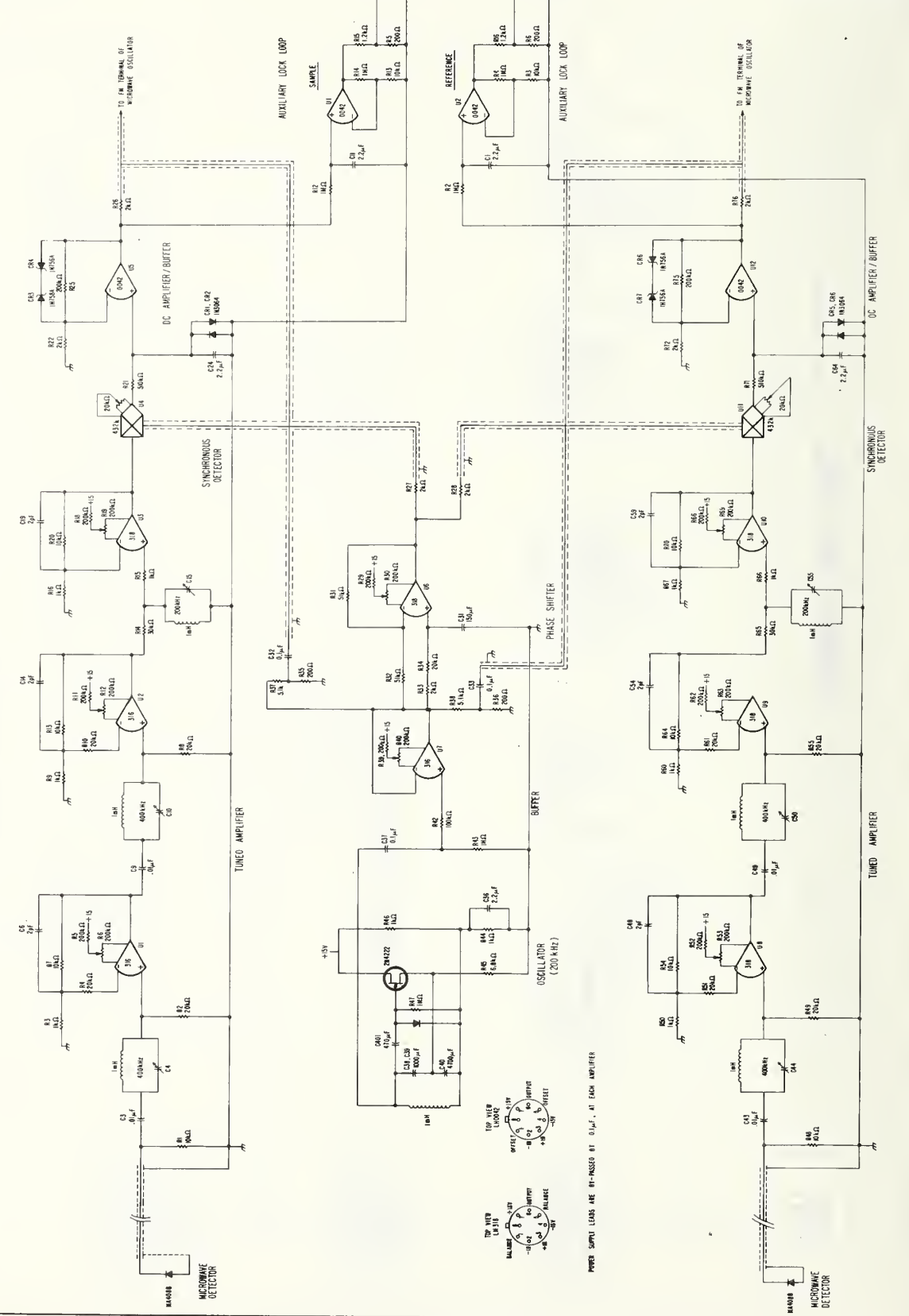

Figure 3. Block diagram of the frequency lock circuit.

REV. NO.	DATE	REVISIONS



POWER SUPPLY LEADS ARE BY-PASSED BY 0.1 μF AT EACH AMPLIFIER

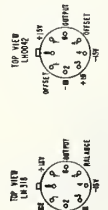

FIG. 4

NATIONAL BUREAU OF STANDARDS	
WASHINGTON, D. C. 20540	
FREQUENCY LOCK ELECTRONICS	
FOR MICROWAVE HYGROMETER	
MODEL	TYPE
OPERATIONS IN CHARGE	SCALE
TECHNICAL MANAGER	PROJECT NO.
DESIGNER	DESIGN DATE
PROJECT ENGINEER	DESIGNED BY
INSTRUMENT MANAGER	APPROVED BY
DATE	GROUP
BY	PRINT PLANT

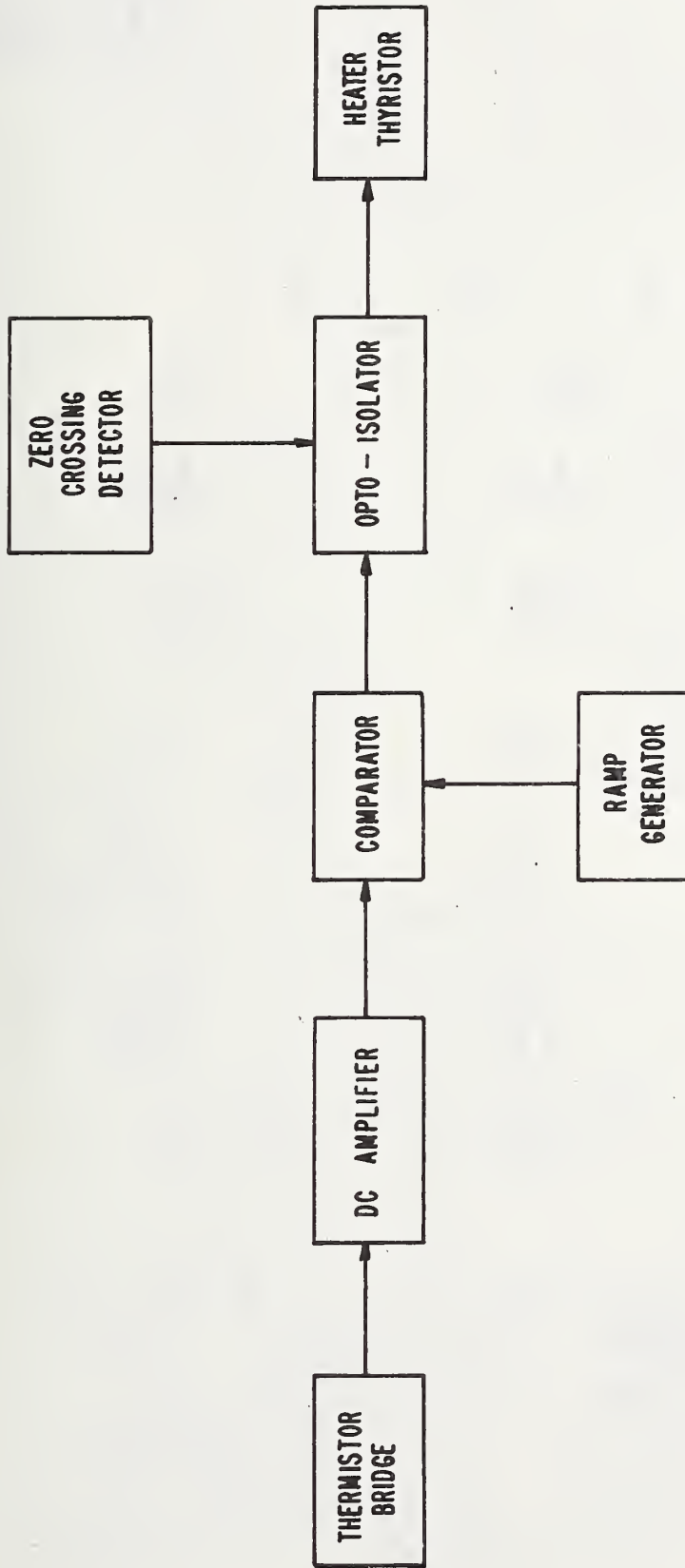

Figure 5. Block diagram of one of the temperature control circuits.

REFERENCE CAVITY FLOW RESTRICTOR VALVE

INNER OVEN TEMPERATURE MONITOR

READOUT

OVEN CONTROLS

DRYER

ROSE AIR WATER INNER THERM

SAMPLE AIR HEATER

VACUUM PUMP

FLOW CONTROL VALVE

AIR FLOW INDICATOR

MAGNETRON

CAUTION

Figure 8. Interior view of one compartment of HBS microwave hyprometer Model III.

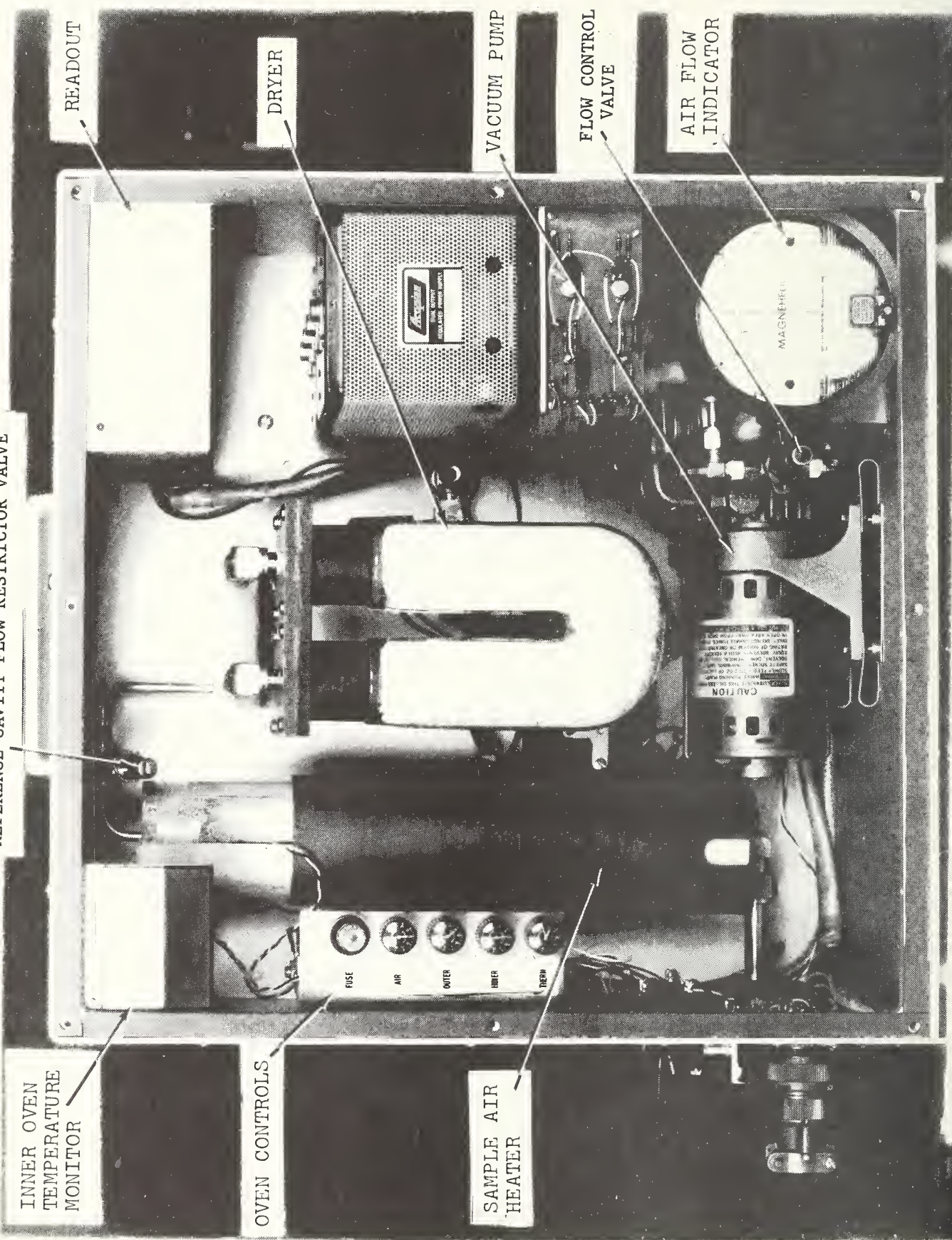

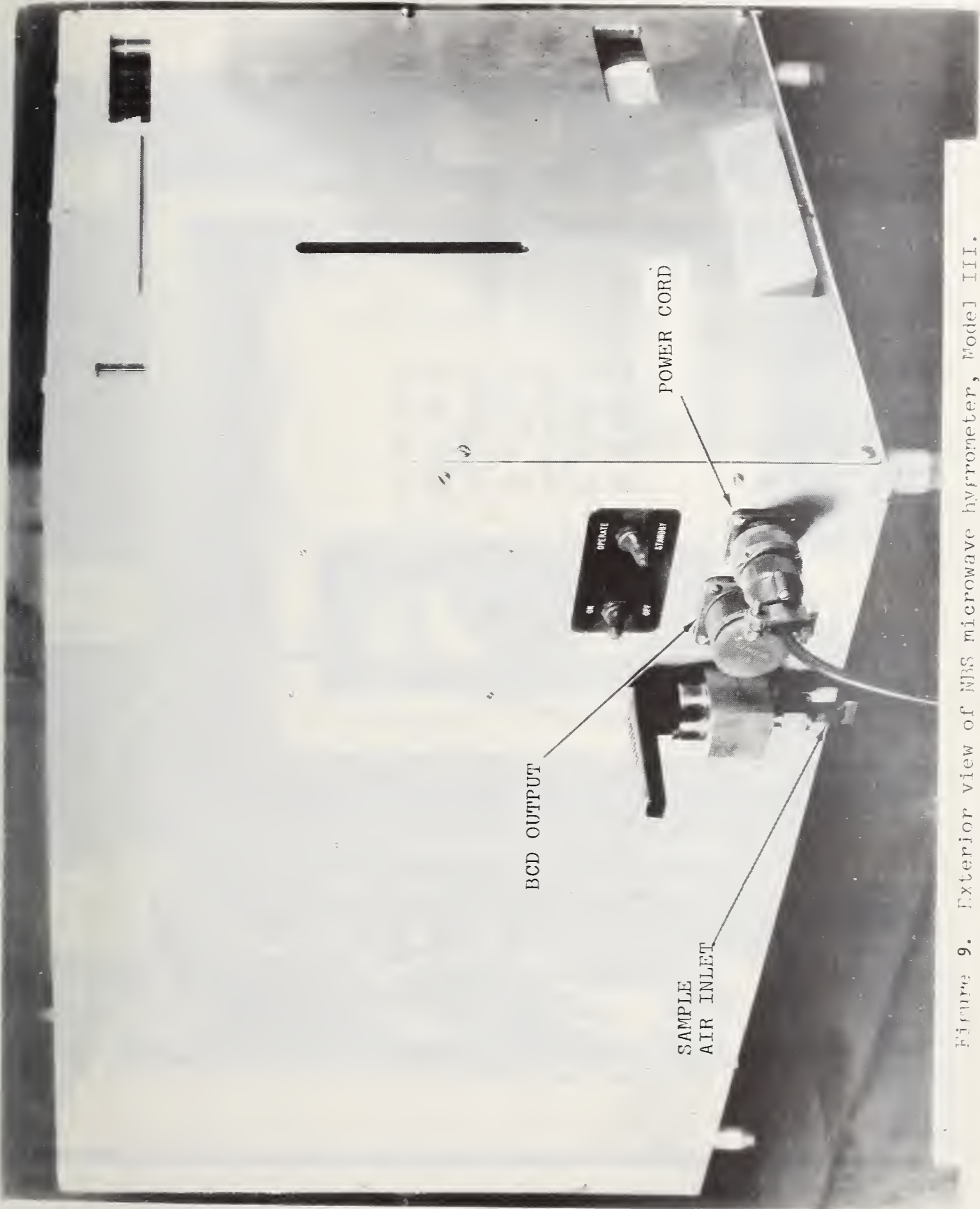

Figure 9. Exterior view of NBS microwave hygrometer, Model III.

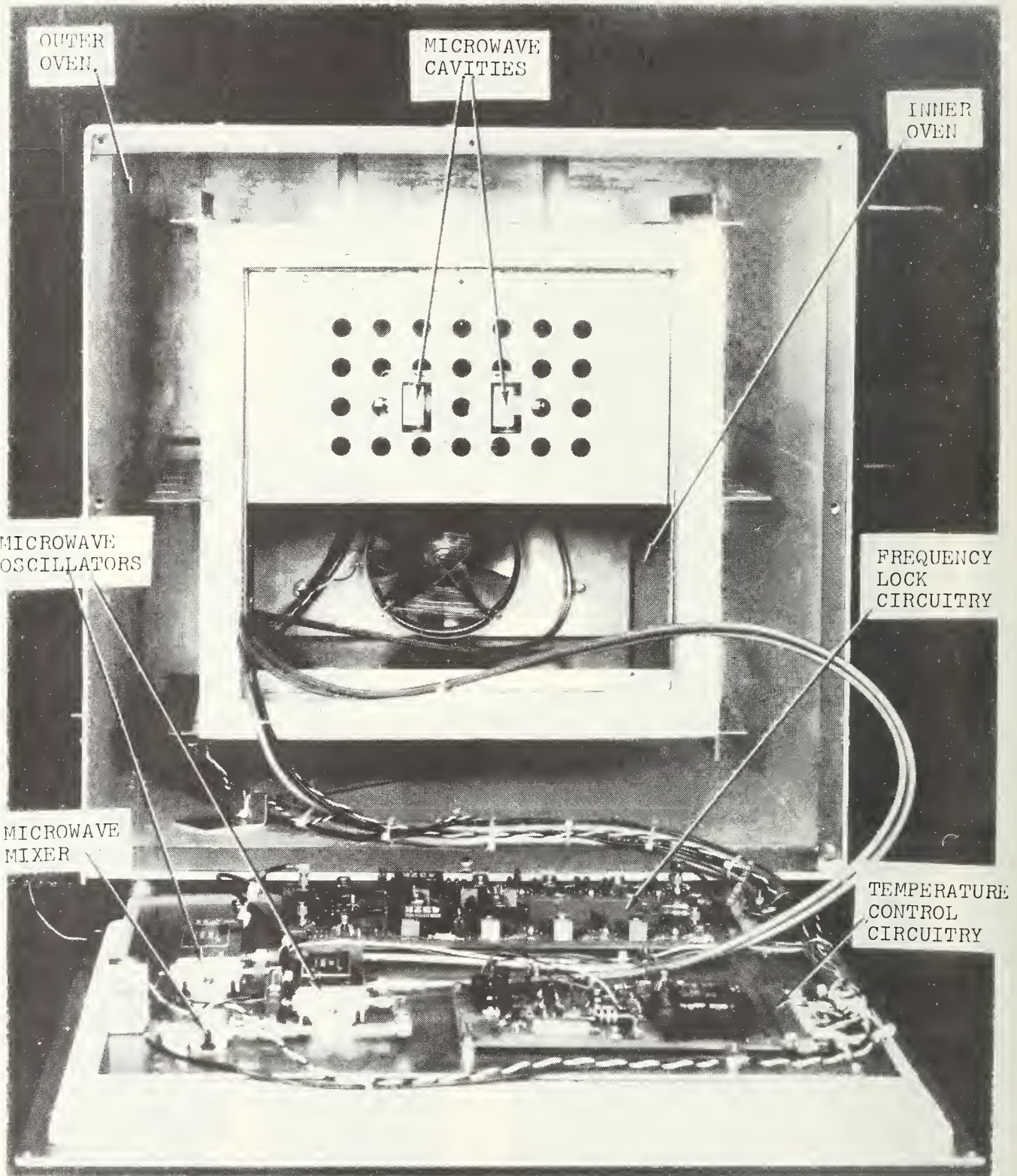

Figure 10. Interior view of the oven compartment of NBS microwave hygrometer, Model III.

REVISIONS		DATE
NO	DESCRIPTION	
1	CHANGES	
2		
3		
4		

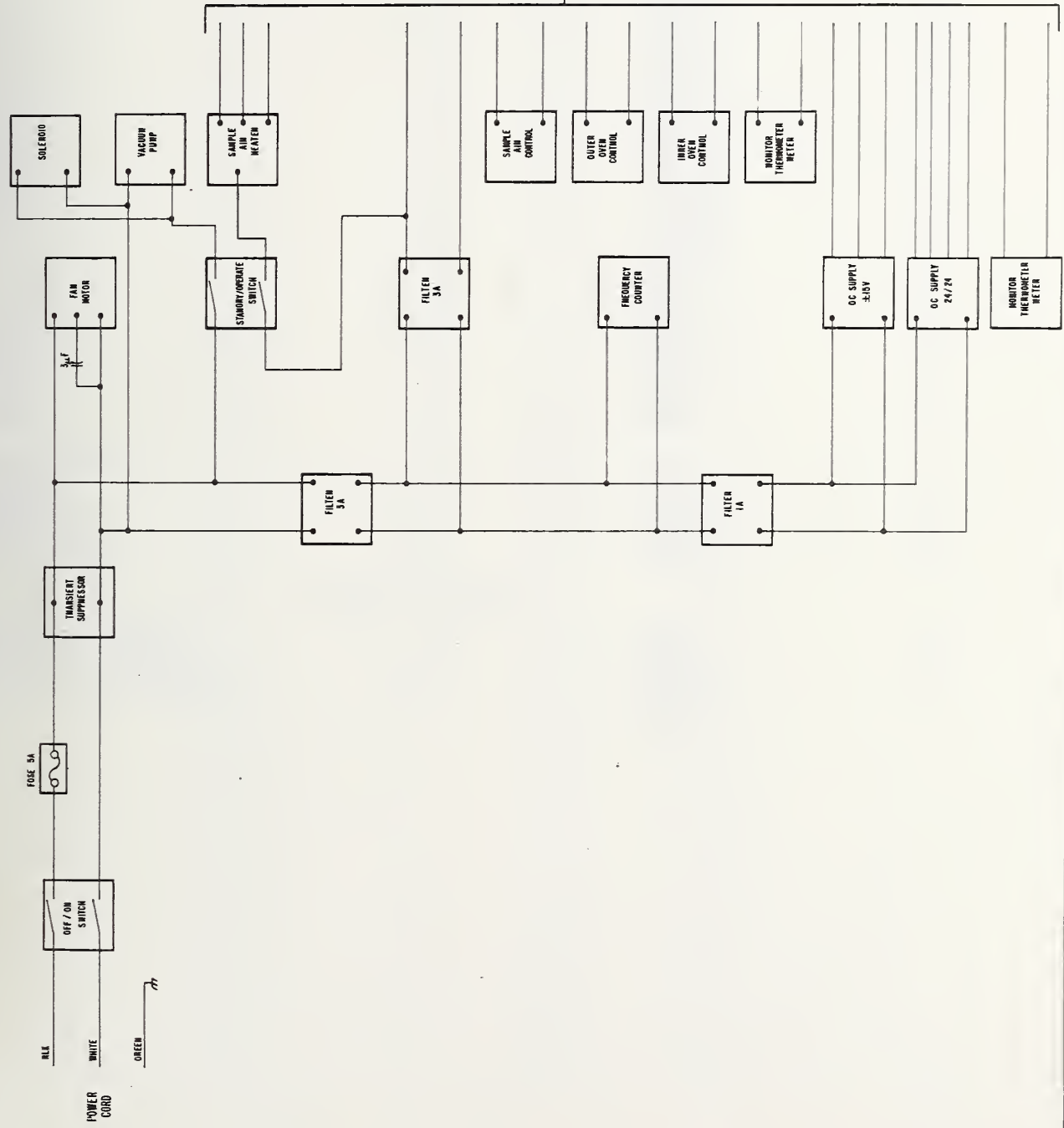

FIG. 11

FIG. NO.	FIG. NO.	NOMENCLATURE
NATIONAL BUREAU OF STANDARDS WASHINGTON, D.C. 20334		
FOR WIRING DIAGRAM		
MODEL III	TYPE	SCALE
	DRYNESS	CHECKER
	P. TUBES	PROJECT AREA
	D. STATEMENT	SUBMITTED BY
	TOLERANCES	APPROVED BY
	ORIGINALS 1.000	CHIEF, SEC.
	ANGLES 1.000	CHIEF ENGINEER
	NO COPY SCALE AND POINT	CHIEF, DIV.
REV. NO.	THIS PRINT ISSUED	

Output Connector Pin Assignments

Function	Counter Pin (Lower Plug)	Wire Color (pairs)	Cannon Connector
1	6	Black	H
2	H	Red	J
4	7	Black	K
8	F	White	L
10	J	Black	M
20	L	Green	N
40	K	Black	P
80	9	Blue	R
100	10	Black	S
200	13	Brown	T
400	12	Black	U
800	11	Yellow	V
1K	N	Black	W
2K	15	Orange	X
4K	S	Red	Y
8K	R	Green	Z
10K	17	Red	a
20K	V	White	b
40K	U	Red	c
80K	T	BLUE	d
BCD Inhibit	E	Red	e
Transfer	P	Yellow	f
Overflow	21	Red	g
BCD Enable	22	Brown	h
	(Upper Plug)		
Measure Enable	4	Red	i
Transfer Enable	6	Orange	k
Conversion Period	11	Green	l
		Blue	

TABLE 1. MICROWAVE DEW-POINT AND FROST-POINT

DELTA R	DEW DEG. C	DELTA R	DEW DEG. C
37000	39.77	32000	37.09
36900	39.72	31900	37.03
36800	39.67	31800	36.97
36700	39.62	31700	36.91
36600	39.57	31600	36.86
36500	39.52	31500	36.80
36400	39.46	31400	36.74
36300	39.41	31300	36.68
36200	39.36	31200	36.62
36100	39.31	31100	36.56
36000	39.26	31000	36.51
35900	39.21	30900	36.45
35800	39.16	30800	36.39
35700	39.10	30700	36.33
35600	39.05	30600	36.27
35500	39.00	30500	36.21
35400	38.95	30400	36.15
35300	38.89	30300	36.09
35200	38.84	30200	36.03
35100	38.79	30100	35.97
35000	38.74	30000	35.91
34900	38.68	29900	35.85
34800	38.63	29800	35.79
34700	38.58	29700	35.73
34600	38.52	29600	35.66
34500	38.47	29500	35.60
34400	38.42	29400	35.54
34300	38.36	29300	35.48
34200	38.31	29200	35.42
34100	38.25	29100	35.36
34000	38.20	29000	35.29
33900	38.15	28900	35.23
33800	38.09	28800	35.17
33700	38.04	28700	35.10
33600	37.98	28600	35.04
33500	37.93	28500	34.98
33400	37.87	28400	34.91
33300	37.82	28300	34.85
33200	37.76	28200	34.79
33100	37.71	28100	34.72
33000	37.65	28000	34.66
32900	37.59	27900	34.59
32800	37.54	27800	34.53
32700	37.48	27700	34.46
32600	37.43	27600	34.40
32500	37.37	27500	34.33
32400	37.31	27400	34.27
32300	37.26	27300	34.20
32200	37.20	27200	34.14
32100	37.14	27100	34.07

TABLE 1. MICROWAVE DEW-POINT AND FROST-POINT

DELTA R	DEW DEG. C	DELTA R	DEW DEG. C
27000	34.00	22000	30.38
26900	33.94	21900	30.30
26800	33.87	21800	30.22
26700	33.80	21700	30.14
26600	33.74	21600	30.06
26500	33.67	21500	29.98
26400	33.60	21400	29.89
26300	33.53	21300	29.81
26200	33.47	21200	29.73
26100	33.40	21100	29.65
26000	33.33	21000	29.57
25900	33.26	20900	29.48
25800	33.19	20800	29.40
25700	33.12	20700	29.32
25600	33.05	20600	29.23
25500	32.98	20500	29.15
25400	32.91	20400	29.06
25300	32.84	20300	28.98
25200	32.77	20200	28.89
25100	32.70	20100	28.81
25000	32.63	20000	28.72
24900	32.56	19900	28.63
24800	32.49	19800	28.55
24700	32.42	19700	28.46
24600	32.34	19600	28.37
24500	32.27	19500	28.28
24400	32.20	19400	28.20
24300	32.13	19300	28.11
24200	32.05	19200	28.02
24100	31.98	19100	27.93
24000	31.91	19000	27.84
23900	31.83	18900	27.75
23800	31.76	18800	27.66
23700	31.68	18700	27.56
23600	31.61	18600	27.47
23500	31.54	18500	27.38
23400	31.46	18400	27.29
23300	31.38	18300	27.20
23200	31.31	18200	27.10
23100	31.23	18100	27.01
23000	31.16	18000	26.91
22900	31.08	17900	26.82
22800	31.00	17800	26.72
22700	30.93	17700	26.63
22600	30.85	17600	26.53
22500	30.77	17500	26.43
22400	30.69	17400	26.34
22300	30.61	17300	26.24
22200	30.54	17200	26.14
22100	30.46	17100	26.04

TABLE 1. MICROWAVE DEW-POINT AND FROST-POINT

DELTA R	DEW DEG. C	DELTA R	DEW DEG. C
17000	25.94	12000	20.19
16900	25.84	11900	20.05
16800	25.74	11800	19.90
16700	25.64	11700	19.76
16600	25.54	11600	19.63
16500	25.44	11500	19.49
16400	25.34	11400	19.35
16300	25.23	11300	19.21
16200	25.13	11200	19.07
16100	25.03	11100	18.92
16000	24.92	11000	18.78
15900	24.82	10900	18.63
15800	24.71	10800	18.49
15700	24.60	10700	18.34
15600	24.50	10600	18.19
15500	24.39	10500	18.04
15400	24.28	10400	17.89
15300	24.17	10300	17.74
15200	24.06	10200	17.58
15100	23.95	10100	17.43
15000	23.84	10000	17.27
14900	23.73	9900	17.11
14800	23.62	9800	16.95
14700	23.51	9700	16.79
14600	23.40	9600	16.63
14500	23.28	9500	16.46
14400	23.17	9400	16.30
14300	23.05	9300	16.13
14200	22.94	9200	15.96
14100	22.82	9100	15.79
14000	22.70	9000	15.62
13900	22.58	8900	15.45
13800	22.47	8800	15.27
13700	22.35	8700	15.09
13600	22.23	8600	14.91
13500	22.10	8500	14.73
13400	21.98	8400	14.55
13300	21.86	8300	14.37
13200	21.74	8200	14.18
13100	21.61	8100	13.99
13000	21.49	8000	13.80
12900	21.36	7900	13.61
12800	21.23	7800	13.41
12700	21.11	7700	13.21
12600	20.98	7600	13.02
12500	20.85	7500	12.81
12400	20.72	7400	12.61
12300	20.59	7300	12.40
12200	20.46	7200	12.19
12100	20.32	7100	11.98

TABLE 1. MICROWAVE DEW-POINT AND FROST-POINT

DELTA R	DEW DEG. C	DELTA R	DEW DEG. C	FROST DEG. C
7000	11.77	3080	-.05	-.05
6900	11.55	3060	-.14	-.13
6800	11.33	3040	-.23	-.21
6700	11.11	3020	-.33	-.29
6600	10.88	3000	-.42	-.37
6500	10.65	2980	-.51	-.45
6400	10.42	2960	-.60	-.53
6300	10.18	2940	-.70	-.61
6200	9.95	2920	-.79	-.69
6100	9.70	2900	-.89	-.78
6000	9.46	2880	-.98	-.86
5900	9.21	2860	-1.08	-.95
5800	8.96	2840	-1.18	-1.03
5700	8.70	2820	-1.27	-1.11
5600	8.44	2800	-1.37	-1.20
5500	8.17	2780	-1.47	-1.29
5400	7.91	2760	-1.57	-1.37
5300	7.63	2740	-1.67	-1.46
5200	7.35	2720	-1.77	-1.55
5100	7.07	2700	-1.87	-1.64
5000	6.78	2680	-1.97	-1.73
4900	6.49	2660	-2.07	-1.82
4800	6.19	2640	-2.18	-1.91
4700	5.89	2620	-2.28	-2.00
4600	5.58	2600	-2.39	-2.09
4500	5.26	2580	-2.49	-2.18
4400	4.94	2560	-2.60	-2.28
4300	4.62	2540	-2.70	-2.37
4200	4.28	2520	-2.81	-2.46
4100	3.94	2500	-2.92	-2.56
4000	3.59	2480	-3.03	-2.65
3900	3.23	2460	-3.14	-2.75
3800	2.87	2440	-3.25	-2.85
3700	2.50	2420	-3.36	-2.95
3600	2.11	2400	-3.47	-3.05
3500	1.72	2380	-3.58	-3.14
3400	1.32	2360	-3.70	-3.25
3300	.91	2340	-3.81	-3.35
3200	.49	2320	-3.93	-3.45
3100	.05	2300	-4.04	-3.55
		2280	-4.16	-3.65
		2260	-4.28	-3.76
		2240	-4.40	-3.86
		2220	-4.52	-3.97
		2200	-4.64	-4.08
		2180	-4.76	-4.18
		2160	-4.89	-4.29
		2140	-5.01	-4.40
		2120	-5.13	-4.51
		2100	-5.26	-4.63

TABLE 1. MICROWAVE DEW-POINT AND FROST-POINT

DELTA R	DEW DEG. C	FROST DEG. C	DELTA R	DEW DEG. C	FROST DEG. C
2080	-5.39	-4.74	1080	-13.75	-12.25
2060	-5.52	-4.85	1060	-13.98	-12.46
2040	-5.65	-4.97	1040	-14.21	-12.67
2020	-5.78	-5.08	1020	-14.45	-12.89
2000	-5.91	-5.20	1000	-14.69	-13.11
1980	-6.04	-5.32	980	-14.93	-13.33
1960	-6.17	-5.44	960	-15.18	-13.56
1940	-6.31	-5.56	940	-15.44	-13.79
1920	-6.45	-5.68	920	-15.69	-14.03
1900	-6.58	-5.80	900	-15.96	-14.27
1880	-6.72	-5.92	880	-16.22	-14.52
1860	-6.86	-6.05	860	-16.50	-14.77
1840	-7.00	-6.17	840	-16.78	-15.03
1820	-7.15	-6.30	820	-17.06	-15.29
1800	-7.29	-6.43	800	-17.35	-15.56
1780	-7.44	-6.56	780	-17.65	-15.83
1760	-7.58	-6.69	760	-17.96	-16.12
1740	-7.73	-6.82	740	-18.27	-16.40
1720	-7.88	-6.96	720	-18.58	-16.70
1700	-8.03	-7.09	700	-18.91	-17.00
1680	-8.19	-7.23	680	-19.25	-17.31
1660	-8.34	-7.37	660	-19.59	-17.63
1640	-8.50	-7.51	640	-19.94	-17.96
1620	-8.66	-7.65	620	-20.30	-18.30
1600	-8.82	-7.79	600	-20.67	-18.65
1580	-8.98	-7.94	590	-20.87	-18.83
1560	-9.14	-8.08	580	-21.08	-19.01
1540	-9.31	-8.23	570	-21.28	-19.19
1520	-9.48	-8.38	560	-21.49	-19.38
1500	-9.64	-8.53	550	-21.70	-19.57
1480	-9.82	-8.69	540	-21.92	-19.76
1460	-9.99	-8.84	530	-22.14	-19.96
1440	-10.16	-9.00	520	-22.36	-20.16
1420	-10.34	-9.16	510	-22.59	-20.36
1400	-10.52	-9.32	500	-22.82	-20.57
1380	-10.70	-9.49	490	-23.06	-20.78
1360	-10.89	-9.65	480	-23.30	-21.00
1340	-11.07	-9.82	470	-23.54	-21.22
1320	-11.26	-9.99	460	-23.79	-21.44
1300	-11.45	-10.17	450	-24.04	-21.67
1280	-11.65	-10.34	440	-24.30	-21.90
1260	-11.85	-10.52	430	-24.57	-22.14
1240	-12.04	-10.70	420	-24.84	-22.38
1220	-12.25	-10.88	410	-25.11	-22.63
1200	-12.45	-11.07	400	-25.40	-22.88
1180	-12.66	-11.26	390	-25.68	-23.14
1160	-12.87	-11.45	380	-25.98	-23.40
1140	-13.09	-11.65	370	-26.28	-23.68
1120	-13.30	-11.84	360	-26.59	-23.95
1100	-13.53	-12.05	350	-26.91	-24.24

TABLE 1. MICROWAVE DEW-POINT AND FROST-POINT

DELTA R	DEW DEG. C	FROST DEG. C
340	-27.23	-24.53
330	-27.56	-24.83
320	-27.91	-25.14
310	-28.26	-25.46
300	-28.62	-25.79
290	-28.99	-26.13
280	-29.38	-26.48
270	-29.78	-26.84
260	-30.19	-27.34
250	-30.61	-27.73
240	-31.05	-28.13
230	-31.51	-28.54
220	-31.98	-28.98
210	-32.48	-29.43
200	-32.99	-29.90
190	-33.53	-30.40
180	-34.10	-30.92
170	-34.69	-31.47
160	-35.31	-32.05
150	-35.97	-32.66
140	-36.67	-33.32
130	-37.42	-34.02
120	-38.21	-34.77
110	-39.07	-35.59
100	-39.99	-36.48
90		-37.46
85		-37.98
80		-38.54
75		-39.13
70		-39.76
65		-40.44
60		-41.16
55		-41.95
50		-42.80
45		-43.74
40		-44.78
35		-45.95
30		-47.30
25		-48.87
20		-50.76
15		-53.17

TABLE 2. MICROWAVE VAPOR PRESSURE

DELTA R	VAPOR PRESSURE, PASCALS	DELTA R	VAPOR PRESSURE, PASCALS	DELTA R	VAPOR PRESSURE, PASCALS
37000	7294.52	32000	6304.67	27000	5317.65
36900	7274.69	31900	6284.90	26900	5297.93
36800	7254.86	31800	6265.14	26800	5278.22
36700	7235.03	31700	6245.38	26700	5258.50
36600	7215.21	31600	6225.62	26600	5238.79
36500	7195.38	31500	6205.85	26500	5219.07
36400	7175.56	31400	6186.09	26400	5199.36
36300	7155.74	31300	6166.34	26300	5179.65
36200	7135.92	31200	6146.58	26200	5159.93
36100	7116.10	31100	6126.82	26100	5140.22
36000	7096.28	31000	6107.07	26000	5120.51
35900	7076.47	30900	6087.31	25900	5100.80
35800	7056.65	30800	6067.56	25800	5081.09
35700	7036.84	30700	6047.81	25700	5061.38
35600	7017.03	30600	6028.06	25600	5041.67
35500	6997.21	30500	6008.31	25500	5021.97
35400	6977.41	30400	5988.56	25400	5002.26
35300	6957.60	30300	5968.81	25300	4982.55
35200	6937.79	30200	5949.06	25200	4962.85
35100	6917.99	30100	5929.32	25100	4943.14
35000	6898.18	30000	5909.57	25000	4923.44
34900	6878.38	29900	5889.83	24900	4903.74
34800	6858.58	29800	5870.08	24800	4884.03
34700	6838.78	29700	5850.34	24700	4864.33
34600	6818.98	29600	5830.60	24600	4844.63
34500	6799.19	29500	5810.86	24500	4824.93
34400	6779.39	29400	5791.12	24400	4805.23
34300	6759.60	29300	5771.38	24300	4785.53
34200	6739.80	29200	5751.65	24200	4765.83
34100	6720.01	29100	5731.91	24100	4746.13
34000	6700.22	29000	5712.18	24000	4726.44
33900	6680.43	28900	5692.44	23900	4706.74
33800	6660.64	28800	5672.71	23800	4687.04
33700	6640.86	28700	5652.97	23700	4667.34
33600	6621.07	28600	5633.24	23600	4647.65
33500	6601.29	28500	5613.51	23500	4627.95
33400	6581.50	28400	5593.78	23400	4608.26
33300	6561.72	28300	5574.05	23300	4588.57
33200	6541.94	28200	5554.32	23200	4568.87
33100	6522.16	28100	5534.60	23100	4549.18
33000	6502.38	28000	5514.87	23000	4529.49
32900	6482.61	27900	5495.15	22900	4509.79
32800	6462.83	27800	5475.42	22800	4490.10
32700	6443.06	27700	5455.70	22700	4470.41
32600	6423.28	27600	5435.97	22600	4450.72
32500	6403.51	27500	5416.25	22500	4431.03
32400	6383.74	27400	5396.53	22400	4411.34
32300	6363.97	27300	5376.81	22300	4391.65
32200	6344.20	27200	5357.09	22200	4371.96
32100	6324.44	27100	5337.37	22100	4352.27

TABLE 2. MICROWAVE VAPOR PRESSURE

DELTA R	VAPOR PRESSURE, PASCALS	DELTA R	VAPOR PRESSURE, PASCALS	DELTA R	VAPOR PRESSURE, PASCALS
22000	4332.59	17000	3348.59	12000	2364.79
21900	4312.90	16900	3328.92	11900	2345.11
21800	4293.21	16800	3309.24	11800	2325.43
21700	4273.53	16700	3289.57	11700	2305.75
21600	4253.84	16600	3269.89	11600	2286.06
21500	4234.15	16500	3250.22	11500	2266.38
21400	4214.47	16400	3230.54	11400	2246.70
21300	4194.78	16300	3210.87	11300	2227.02
21200	4175.10	16200	3191.19	11200	2207.34
21100	4155.41	16100	3171.52	11100	2187.65
21000	4135.73	16000	3151.84	11000	2167.97
20900	4116.05	15900	3132.17	10900	2148.29
20800	4096.36	15800	3112.50	10800	2128.60
20700	4076.68	15700	3092.82	10700	2108.92
20600	4057.00	15600	3073.15	10600	2089.24
20500	4037.32	15500	3053.47	10500	2069.55
20400	4017.63	15400	3033.80	10400	2049.87
20300	3997.95	15300	3014.12	10300	2030.18
20200	3978.27	15200	2994.45	10200	2010.49
20100	3958.59	15100	2974.77	10100	1990.81
20000	3938.91	15000	2955.10	10000	1971.12
19900	3919.23	14900	2935.42	9950	1961.28
19800	3899.55	14800	2915.75	9900	1951.43
19700	3879.87	14700	2896.07	9850	1941.59
19600	3860.19	14600	2876.40	9800	1931.75
19500	3840.51	14500	2856.72	9750	1921.90
19400	3820.83	14400	2837.05	9700	1912.06
19300	3801.15	14300	2817.37	9650	1902.21
19200	3781.47	14200	2797.70	9600	1892.37
19100	3761.80	14100	2778.02	9550	1882.52
19000	3742.12	14000	2758.34	9500	1872.68
18900	3722.44	13900	2738.67	9450	1862.84
18800	3702.76	13800	2718.99	9400	1852.99
18700	3683.09	13700	2699.31	9350	1843.15
18600	3663.41	13600	2679.64	9300	1833.30
18500	3643.73	13500	2659.96	9250	1823.46
18400	3624.05	13400	2640.28	9200	1813.61
18300	3604.38	13300	2620.61	9150	1803.77
18200	3584.70	13200	2600.93	9100	1793.92
18100	3565.02	13100	2581.25	9050	1784.07
18000	3545.35	13000	2561.58	9000	1774.23
17900	3525.67	12900	2541.90	8950	1764.38
17800	3506.00	12800	2522.22	8900	1754.54
17700	3486.32	12700	2502.54	8850	1744.69
17600	3466.64	12600	2482.86	8800	1734.84
17500	3446.97	12500	2463.18	8750	1725.00
17400	3427.29	12400	2443.51	8700	1715.15
17300	3407.62	12300	2423.83	8650	1705.30
17200	3387.94	12200	2404.15	8600	1695.46
17100	3368.27	12100	2384.47	8550	1685.61

TABLE 2. MICROWAVE VAPOR PRESSURE

DELTA R	VAPOR PRESSURE, PASCALS	DELTA R	VAPOR PRESSURE, PASCALS	DELTA R	VAPOR PRESSURE, PASCALS
8500	1675.76	6000	1183.23	3500	690.26
8450	1665.92	5950	1173.37	3450	680.39
8400	1656.07	5900	1163.52	3400	670.53
8350	1646.22	5850	1153.66	3350	660.66
8300	1636.37	5800	1143.81	3300	650.80
8250	1626.53	5750	1133.95	3250	640.93
8200	1616.68	5700	1124.10	3200	631.06
8150	1606.83	5650	1114.24	3150	621.20
8100	1596.98	5600	1104.39	3100	611.33
8050	1587.14	5550	1094.53	3050	601.47
8000	1577.29	5500	1084.67	3000	591.60
7950	1567.44	5450	1074.82	2950	581.73
7900	1557.59	5400	1064.96	2900	571.87
7850	1547.74	5350	1055.10	2850	562.00
7800	1537.89	5300	1045.25	2800	552.13
7750	1528.04	5250	1035.39	2750	542.26
7700	1518.19	5200	1025.53	2700	532.39
7650	1508.34	5150	1015.67	2650	522.53
7600	1498.49	5100	1005.81	2600	512.66
7550	1488.65	5050	995.96	2550	502.79
7500	1478.80	5000	986.10	2500	492.92
7450	1468.95	4950	976.24	2450	483.05
7400	1459.10	4900	966.38	2400	473.18
7350	1449.25	4850	956.52	2350	463.31
7300	1439.39	4800	946.66	2300	453.44
7250	1429.54	4750	936.80	2250	443.57
7200	1419.69	4700	926.94	2200	433.70
7150	1409.84	4650	917.09	2150	423.83
7100	1399.99	4600	907.23	2100	413.96
7050	1390.14	4550	897.37	2050	404.09
7000	1380.29	4500	887.50	2000	394.22
6950	1370.44	4450	877.64	1950	384.34
6900	1360.59	4400	867.78	1900	374.47
6850	1350.73	4350	857.92	1850	364.60
6800	1340.88	4300	848.06	1800	354.73
6750	1331.03	4250	838.20	1750	344.86
6700	1321.18	4200	828.34	1700	334.98
6650	1311.33	4150	818.48	1650	325.11
6600	1301.47	4100	808.62	1600	315.24
6550	1291.62	4050	798.75	1550	305.36
6500	1281.77	4000	788.89	1500	295.49
6450	1271.91	3950	779.03	1450	285.61
6400	1262.06	3900	769.17	1400	275.74
6350	1252.21	3850	759.30	1350	265.87
6300	1242.35	3800	749.44	1300	255.99
6250	1232.50	3750	739.58	1250	246.12
6200	1222.65	3700	729.71	1200	236.24
6150	1212.79	3650	719.85	1150	226.36
6100	1202.94	3600	709.98	1100	216.49
6050	1193.08	3550	700.12	1050	206.61

TABLE 2. MICROWAVE VAPOR PRESSURE

DELTA R	VAPOR PRESSURE, PASCALS
1000	196.74
950	186.86
900	176.93
850	167.10
800	157.23
750	147.35
700	137.47
650	127.59
600	117.71
550	107.84
500	97.96
450	88.08
400	78.20
350	68.32
300	58.44
250	48.56
200	38.68
150	28.79
100	18.91
80	14.96
60	11.01
40	7.05
20	3.10

U.S. DEPT. OF COMM. BIBLIOGRAPHIC DATA SHEET	1. PUBLICATION OR REPORT NO. NBSIR 75-758	2. Gov't Accession No.	3. Recipient's Accession No.
4. TITLE AND SUBTITLE Operational Manual for Microwave Hygrometer Model III		5. Publication Date July 1975	6. Performing Organization Code
		7. AUTHOR(S) Daniel P. Stokesberry & Saburo Hasegawa	
9. PERFORMING ORGANIZATION NAME AND ADDRESS NATIONAL BUREAU OF STANDARDS DEPARTMENT OF COMMERCE WASHINGTON, D.C. 20234		10. Project/Task/Work Unit No.	11. Contract/Grant No.
		12. Sponsoring Organization Name and Complete Address (Street, City, State, ZIP) Naval Air Systems Command Department of the Navy Washington, D. C. 20360	
15. SUPPLEMENTARY NOTES			
16. ABSTRACT (A 200-word or less factual summary of most significant information. If document includes a significant bibliography or literature survey, mention it here.) <p>This is an operational manual for the NBS microwave hygrometer, Model III. It covers the design, operation and performance of the hygrometer. It is capable of measuring water vapor equivalent to the dew/frost point range of 40°C to -53°C.</p> <p>When compared with the NBS two-pressure humidity generator over the dew/frost point range of 40°C to -53°C, the following estimates of the one sigma random errors were obtained:</p> <ul style="list-style-type: none"> a) 0.02°C for dew points 40°C to 20°C b) 0.03°C for dew points 20°C to 0°C c) 0.09°C for frost points 0°C to -27°C d) 0.60°C for frost points -27°C to -53°C 			
17. KEY WORDS (six to twelve entries; alphabetical order; capitalize only the first letter of the first key word unless a proper name; separated by semicolons) Dew-point; hygrometer; microwave hygrometer			
18. AVAILABILITY <input type="checkbox"/> Unlimited <input checked="" type="checkbox"/> For Official Distribution. Do Not Release to NTIS <input type="checkbox"/> Order From Sup. of Doc., U.S. Government Printing Office Washington, D.C. 20402, SD Cat. No. C13 <input type="checkbox"/> Order From National Technical Information Service (NTIS) Springfield, Virginia 22151		19. SECURITY CLASS (THIS REPORT) UNCLASSIFIED	21. NO. OF PAGES
		20. SECURITY CLASS (THIS PAGE) UNCLASSIFIED	22. Price



