

NBSIR 74-588

Development of a Bench Test for Type X Core Gypsum Board

J. L. Houser, Research Associate
Gypsum Association

Programmatic Center for Fire Research
Institute for Applied Technology
National Bureau of Standards
Washington, D. C. 20234

December 1974

Final Report

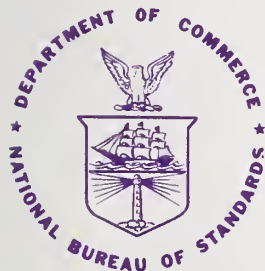

U.S. DEPARTMENT OF COMMERCE
NATIONAL BUREAU OF STANDARDS

NBSIR 74-588

**DEVELOPMENT OF A BENCH TEST FOR
TYPE X CORE GYPSUM BOARD**

J. L. Houser, Research Associate
Gypsum Association

Programmatic Center for Fire Research
Institute for Applied Technology
National Bureau of Standards
Washington, D. C. 20234

December 1974

Final Report

U.S. DEPARTMENT OF COMMERCE, Frederick B. Dent, Secretary
NATIONAL BUREAU OF STANDARDS, Richard W. Roberts, Director

CONTENTS

	Page
1. INTRODUCTION	1
2. BACKGROUND	2
3. TEST APPARATUS	4
4. TEST SPECIMENS	9
5. TEST PROCEDURE	10
6. CALIBRATION OF APPARATUS	13
7. DISCUSSION OF RESULTS WITH PRESENT APPARATUS	14
8. DATA SECTION	18
8.1. Test Results of 1/2" Type X and Improved Formula Type X	18
8.2. Test Results of 5/8" Type X and Improved Formula Type X	19
8.3. Test Results of 1/2" and 5/8" Regular Formula	20
9. CONCLUSIONS	21
10. RECOMMENDATIONS FOR FUTURE WORK.	21
APPENDIX A. THERMAL VALUES OF GYPSUM	22
APPENDIX B. SI CONVERSION FACTORS.	22
REFERENCES.	23

DEVELOPMENT OF A BENCH TEST FOR TYPE X CORE GYPSUM BOARD

J. L. Houser¹

This paper describes the development of a test method for determining that the core material in a gypsum board sample qualifies as Type X. A 2 inch (5.08 cm) by 16 inch (40.64 cm) specimen is flexurally stressed during the test by suspending a weight from the cantilevered end of the test sample. The specimen is swiveled into the center of a two burner turbulent flame at an average temperature of 1,780°F (971°C). The burners are positioned from above and below. The test is terminated when the specimen either breaks or deflects through an arc three times the specimen thickness. Results show this method to be repeatable with a coefficient of variation equal to ± 8 percent for a given type of material from a single manufacturer.

Key words: Building codes; construction materials; fire endurance ratings; fire tests; gypsum.

1. INTRODUCTION

The gypsum industry currently produces gypsum board products at an annual rate in excess of 14 billion square feet [1]². These products constitute more than 80 percent of all finished wall and ceiling surface materials used in the United States construction industry. Approximately one-fifth of this total production is devoted to special fire resistant products that go into systems and assemblies which are required to have a fire endurance rating as determined by the "Standard Method of Fire Tests of Building Construction and Materials", ASTM Designation E 119 [2].

These fire rated assemblies are used as wall systems for occupancy separations and public exitways, chases, shafts, column and beam fire protection and floor/ceiling systems. They are used primarily in commercial, institutional and multi-family residential occupancies and high-rise construction. The basic gypsum board product used in these rated assemblies has a special core formulation that includes noncombustible fibers and is defined generically as Type X by ASTM Standard C 36 [3].

¹This work was conducted while Mr. Houser was a Research Associate for the Gypsum Association at the National Bureau of Standards. He is currently Assistant Merchandise Manager for the Gypsum Products for the Flintkote Company.

²Figures in brackets indicate the literature references at the end of this paper.

Gypsum has several unique properties which make it an effective barrier to fire. Chemically expressed as $\text{CaSO}_4 \cdot 2\text{H}_2\text{O}$ or technically as "dihydrous calcium sulphate", it is about 50 percent water by volume or about 21 percent water by weight. When gypsum is exposed to a high temperature most of the chemically combined water of crystallization is slowly released as steam, a process known as calcination. The temperature behind the plane of calcination is just slightly higher than that of boiling water. Even after calcination is complete the gypsum remaining in place acts as an insulating barrier to the transmission of heat and flame.

In the early 1940's, efforts were made to improve the fire resistive characteristics of regular gypsum wallboard. Experimentation with additives to the core material led to the first patent on a special fire retardant gypsum wallboard. This patent was issued to Michael Croce and Clarence Shuttleworth of the Certain-teed Products Corporation¹ on October 17, 1950 (#2526066) based on work originally filed in 1943 [4]. The first Underwriters' Laboratories (UL) materials listing of special fire retardant gypsum wallboard appeared in 1946. Further refinements of the original patent work resulted in the use of unexpanded vermiculite and siliceous clays to stabilize the core thermally and compensate for the effect of shrinkage during calcination. Glass fibers dispersed throughout the core act as a reinforcing mat to hold the calcined core intact for extended periods of time during exposure to fire.

This report describes the development of a laboratory test method that defines by performance whether mill production material can qualify within known acceptable standards as Type X core gypsum board.

2. BACKGROUND

The need to develop a reliable bench test to determine Type X core gypsum board is demonstrated by the fact that ASTM Committee C-11 on Ceilings and Walls has carried the subject as an agenda item for several years. There are currently two alternative bench test methods under study by C-11 for the determination of Type X core.

One method described in ASTM C-473 [5], suspends a 2 inch (5.08 cm) by 12 inch (30.48 cm) specimen vertically between two Meeker burner flames. The specimen has a 1,000 gram weight attached to the lower edge and failure is recorded when the specimen breaks.

¹Gypsum Division is now part of the Georgia-Pacific Corporation.

The second method uses 2 inch (5.08 cm) by 8 inch (20.32 cm) specimens that are first calcined in a muffle furnace at 800°F (427°C) for two hours. The sample is then placed over a fulcrum and lead shot is added at a measured rate to a cup supported at a cantilevered end. The weight of the shot is measured when the specimen breaks as an indication of the relative strength of the calcined core.

The merits of each of these test methods were considered in the design of the method presented for discussion in this paper. However, after careful visual observations of the behavior of Type X gypsum wallboard during the course of 18 full-scale wall and floor/ceiling ASTM E-119 furnace tests, it was concluded that the forces acting on the wallboard in such severe fire exposures are flexural rather than tensile. This was a paramount consideration in the selection of the orientation for the specimen within the apparatus in this proposed method.

Other considerations were the form and degree of thermal exposure. Following consultation with several experts in the field of combustion, it was decided to produce a premixed turbulent flame impinging on the specimen with a temperature range between 1,500 and 2,000°F. The average flame temperature would then correspond to an exposure time on the standard time-temperature curve in excess of one hour and twenty minutes. In order to achieve consistent results it was also important that the flame area be concentrated in a sharply defined path across the specimen instead of concentric radiations of varying flux.

The criteria set forth for the design of this test method were as follows:

1. The test must relate to accepted large-scale tests in terms of maximum temperatures. (ASTM E 119)
2. The test should give graduated results instead of go/no go.
3. The test must be simple to operate and not depend upon judgment of the operator.
4. The test must give reproducible results with precision within ± 10 percent.
5. The test results should be available within a short period of time.
6. The initial cost of the apparatus and the operating costs should not be excessive.

A series of developmental tests and trials led to the formulation of apparatus details, the selection and preparation of specimens, and a suitable test procedure. The apparatus and test procedure described in the following sections were used in this study and are written in a form which may be suitable as a proposed test method.

3. TEST APPARATUS

Figures 1 and 2 are photographs of the test apparatus. Figure 1 shows the basic apparatus. Note that an asbestos board shield has been provided to protect the vertical fuel line from excessive heat during extended periods of operation. Figure 2 shows the specimen in test position and accompanying instrumentation. Schematic drawings are presented in plan and elevation as figures 3 and 4. A materials list giving dimensions and numbers corresponding to the item shown in the drawings is given in table 1. The apparatus was designed and constructed with as many commonly available standard components as possible to keep costs at a minimum.

Table 1. List of Materials

1. Base Plate - 1/4" Brass - 6 inches by 18 inches
2. Gage and Support Angles - 1/8" Brass
3. Mixing Chamber - Nominal 1-1/2" x 1/2" Copper Reducer (1)
4. Line Valves - 3/8" Laboratory Stop Valve. Lever Handles have been rebored to 9/32" Orifice (2)
5. 1/2" x 3/8" Copper Reducers (2)
6. 3/8" I.D. Rigid Copper Tube. Type "L"
7. 3/8" x 90° Copper Elbows (6)
8. 3/8" x 2" Wing-Tip Burner with .040 inch Opening (2)
9. Sample Holder
Base - 1/2" brass rod
Swivel rack - 1/4" brass rod
10. 1/2" Threaded Disconnect

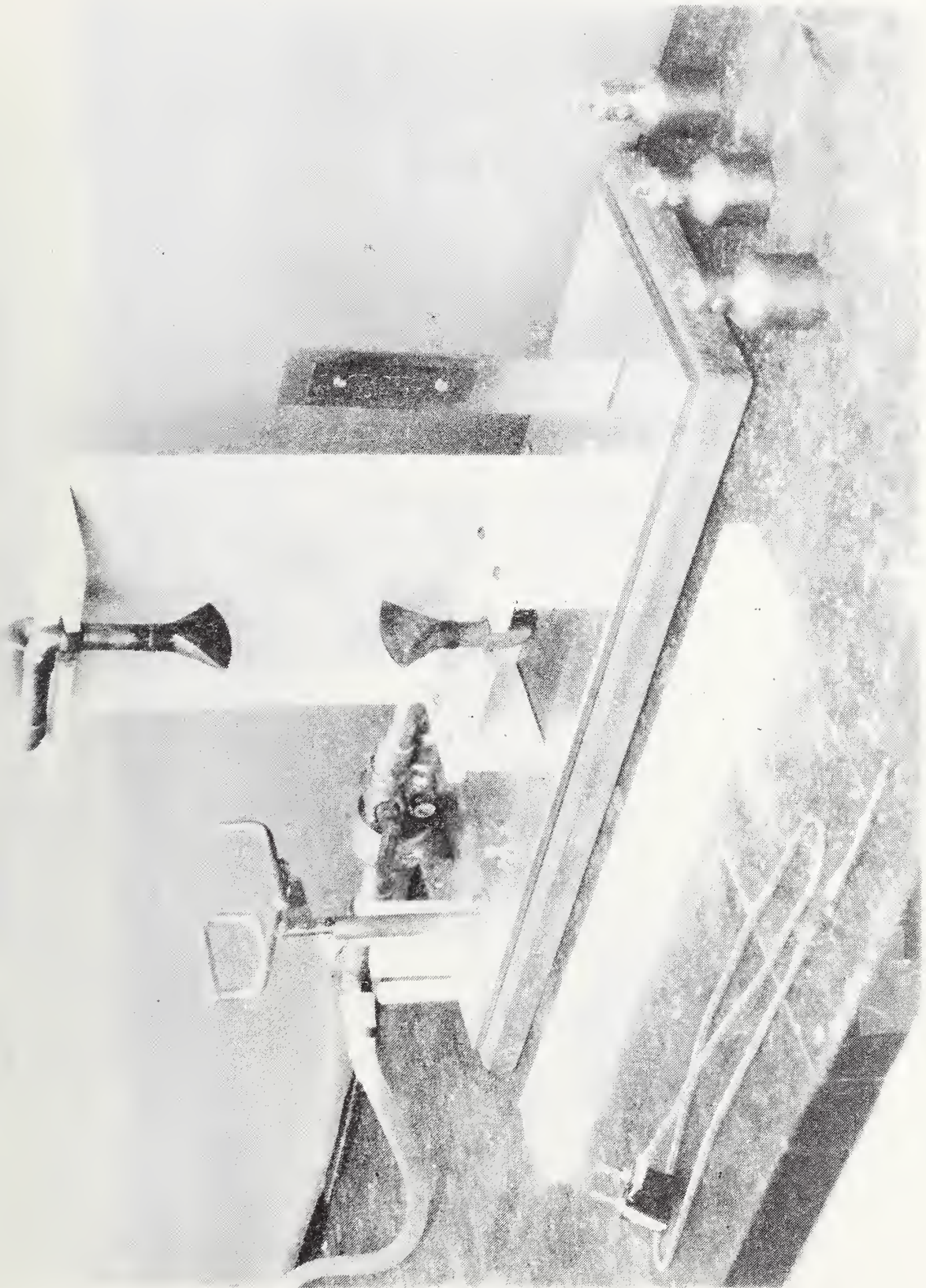

Figure 1. Photograph of Test Equipment

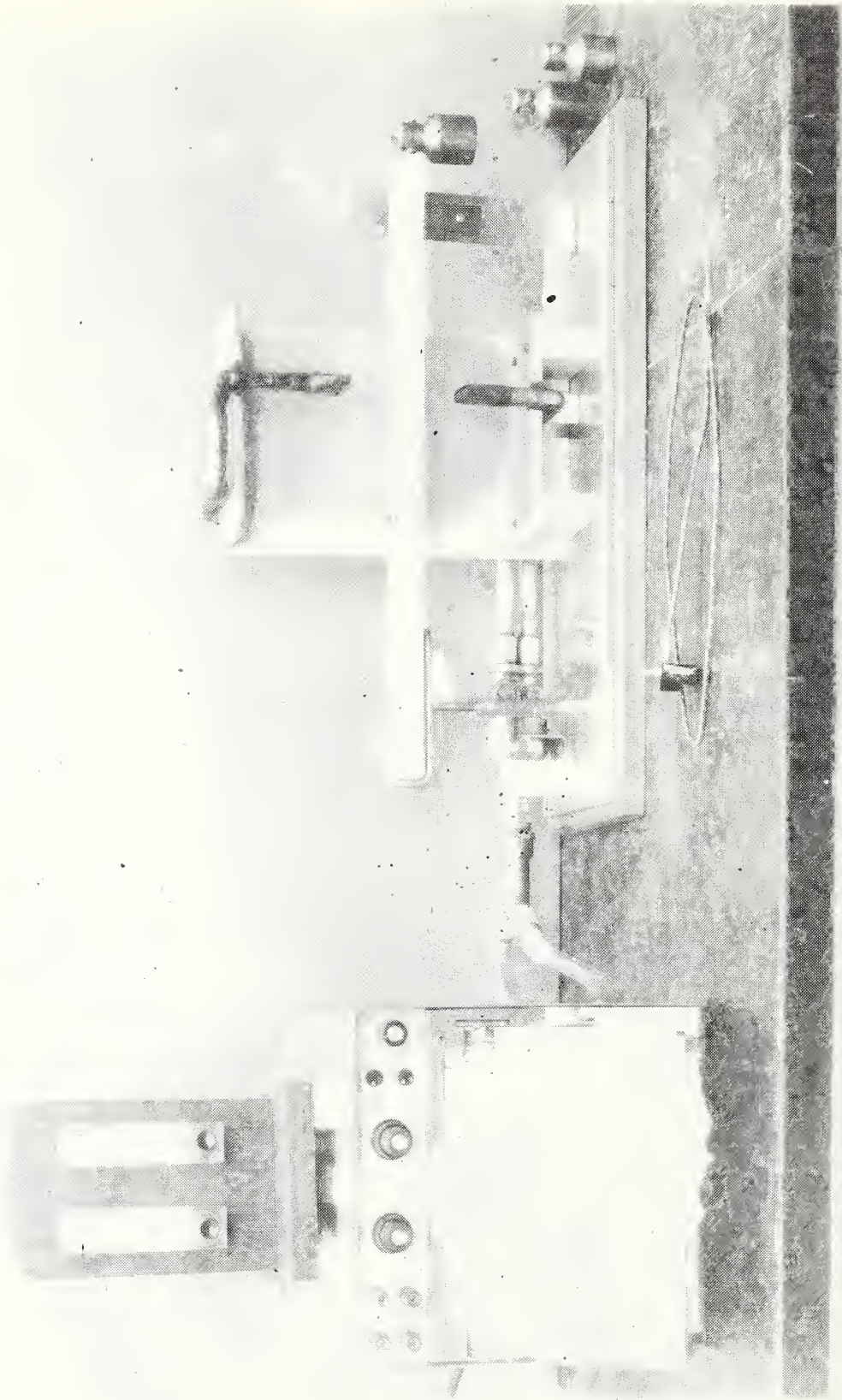

Figure 2. Photograph of Equipment with Instrumentation

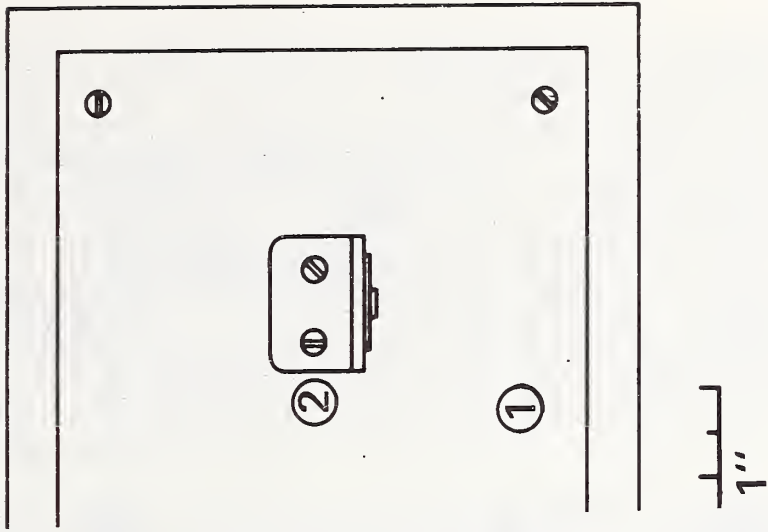
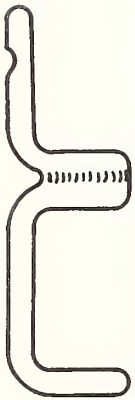
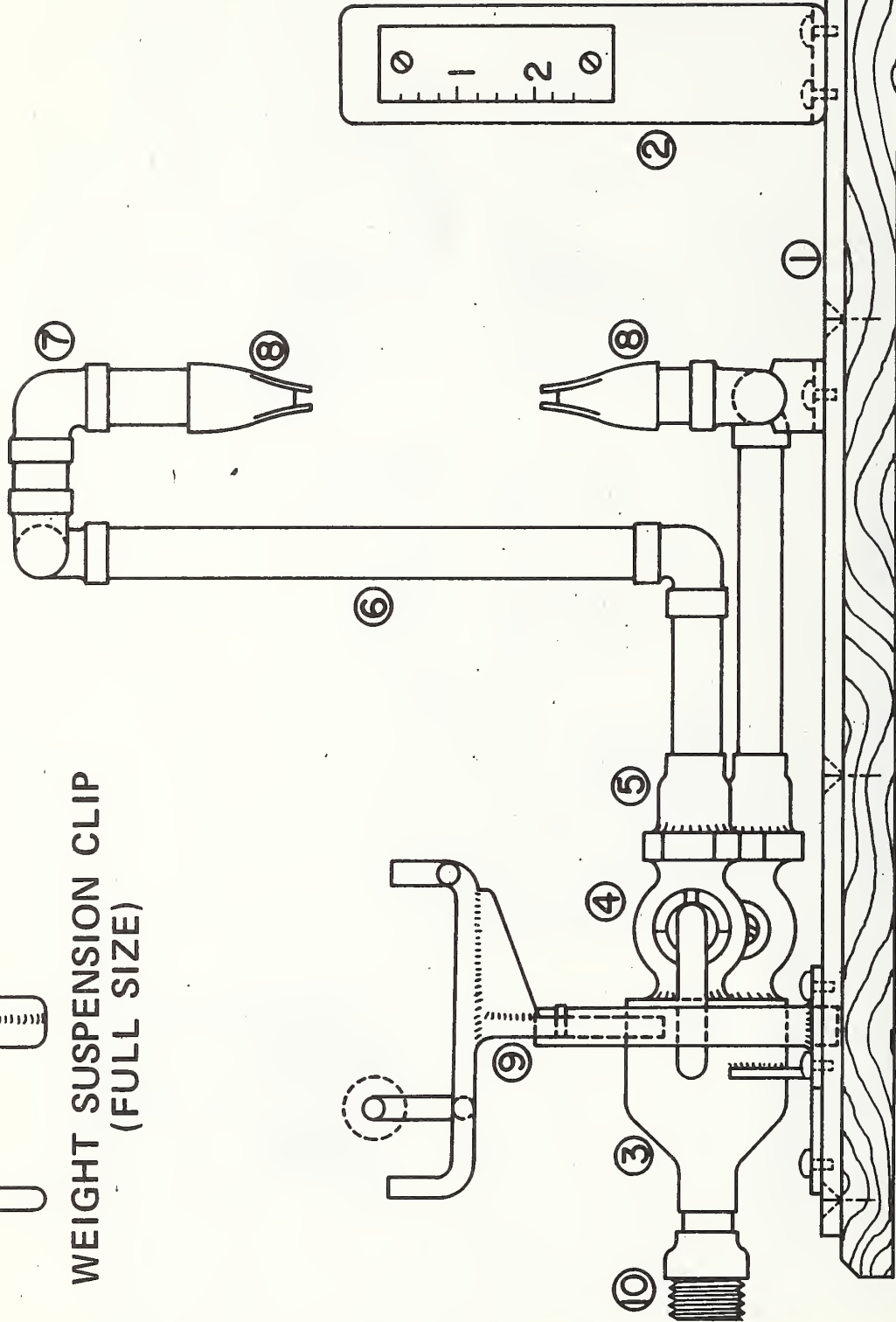

Figure 3. Top View of Apparatus



WEIGHT SUSPENSION CLIP
(FULL SIZE)



ELEVATION SCALE 1/2" = 1"

Figure 4. Schematic Front View of Apparatus

Natural city gas (95% methane) and compressed atmospheric air are mixed thru a "Y" connection just ahead of the threaded disconnect. The air-fuel mixture moves into a mixing chamber that also acts as a constant pressure plenum. From this point the fuel mixture passes through two control level valves and is distributed to the wing-tip burners. The control level valves are used to adjust fuel between the upper and lower burners and to keep the impingement of the flames on the top and bottom surfaces equal. Although these 3/8-inch stopcocks are a common laboratory plumbing item, the orifice of each was enlarged to 9/32 inch diameter to increase the volume of fuel at the burner tips. The wing-tip burner opening width is .040 in, a critical measurement.

It is necessary to use different size sleeves that fit over the upper arm of the specimen holder to keep different thicknesses of board in a level plane. Thin shims may occasionally be required for severe variations in board thickness (commonly referred to as caliper).

4. TEST SPECIMENS

Each specimen was $2 + 1/16$ in (5.08 cm) by $16 + 1/16$ in (40.64 cm) cut from the long or machine direction of the board. The specimens were saw cut rather than scored and snapped to insure close tolerances. Care was exercised in the selection of the specimens to be tested in order to achieve a reasonably good representative sampling. For instance, the specimens were neither cut from the "stream merging points" that occur approximately one-third in from either edge, nor cut any closer than 8 inches in from either edge as many manufacturers may use a "hard edge" formula mix. By following these guidelines the area was avoided where most gypsum boards are reduced in caliper in order to form an exposed, featured, or tapered edge to receive a joint finishing treatment.

Each specimen was conditioned for a period of 24 hours in a $68 \pm 5^\circ\text{F}$ ($20 \pm 2.5^\circ\text{C}$) conditioning room or chamber with a constant 50 ± 5 percent relative humidity (RH). A 9/64 inch hole was drilled through the core one inch from one end of each specimen to accommodate a clip from which a weight was suspended.

At least six specimens were prepared of which four were randomly selected and tested to obtain an average time to failure. The following information about each specimen was recorded:

Manufacturer's name _____
 Product designation _____
 Plant where produced _____
 Production code number _____
 Caliper (thickness) (mm) _____
 Specimen size (cm) _____
 Specimen weight (grams) _____
 Test results (time to failure) (min:sec) _____
 Deflection failure (D) _____ Break (B) _____

5. TEST PROCEDURE

The test was started by igniting the air-fuel mixture. The mixture consisted of city gas and air with flow rate of 0.40 and about 1.0 ft³/min, respectively. An 8 inch probe with a 20 gage chromel-alumel thermocouple attached was then positioned into the specimen holder. Eight temperature points at 3/8-inch intervals were then recorded axially, four across the centerline of the flame and two above and two below at midpoints (see fig. 5)!. An average flame temperature of 1,780 + 25°F (971 + 14°C) (see fig. 6) was achieved. Necessary adjustments in the air-fuel flow rate and control valves were made to stabilize the temperature reading. The thermocouple probe was then removed.

The conditioned specimen was then inserted securely in the specimen holder face up at a 90° angle to the plane of the burners. The weight suspension clip was fastened to the end of the specimen and the proper weight attached, depending on the thickness of test specimen:

Thickness of Specimen	Weight
3/8 in (9.57 mm)	112.5 grams
1/2 in (12.7 mm)	150.0 grams
5/8 in (15.9 mm)	187.5 grams

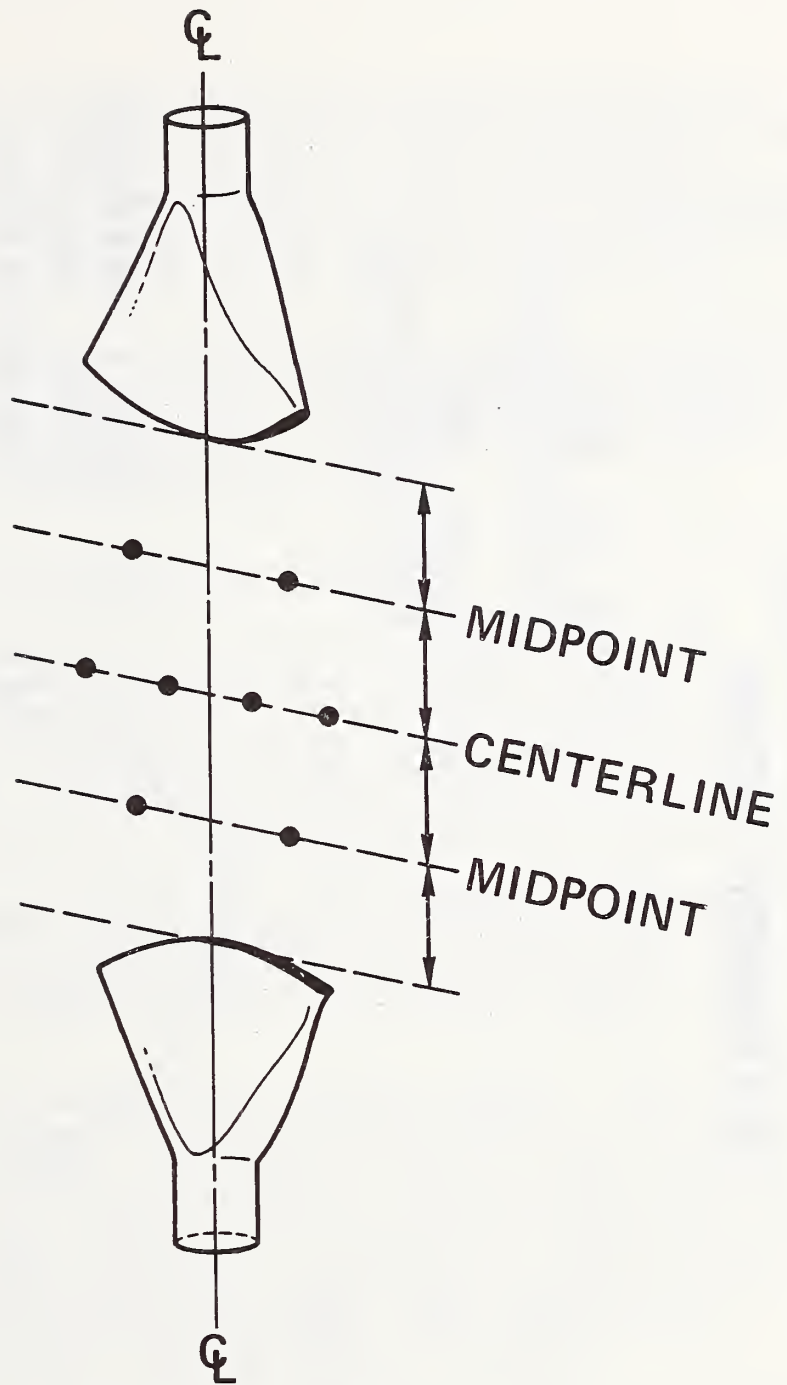

AXIAL POINTS FOR TEMPERATURE MEASUREMENTS

Figure 5. Axial Points for Temperature Measurements

FLAME TEMPERATURE PROFILE IN LUMINOUS REGION

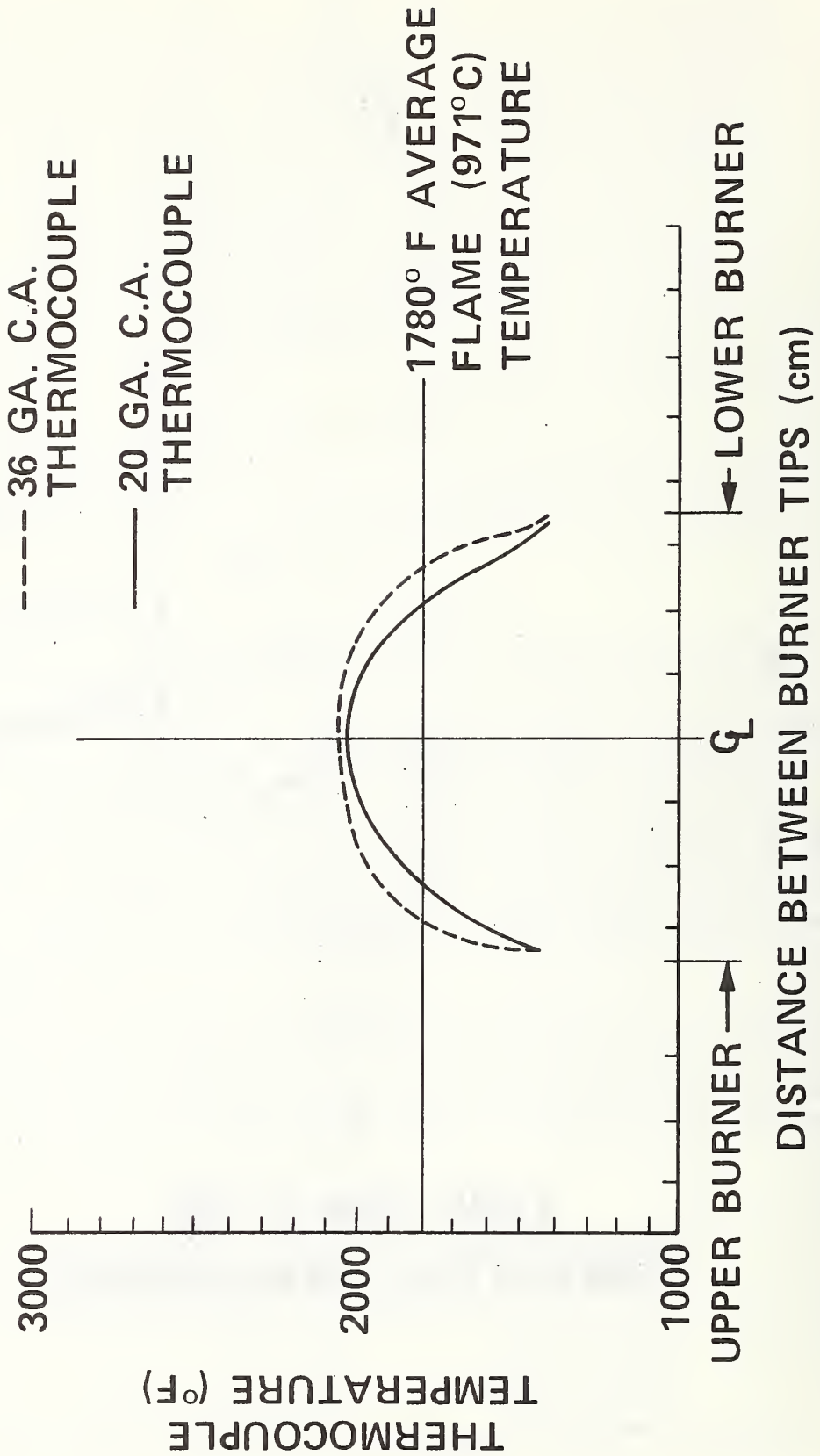

Figure 6. Flame Temperature Profile Based on Two Thermocouples

The specimen was swiveled into the plane of flames and stop watch was started simultaneously. The reading on the face edge of the deflection scale was noted within the first 15 seconds. Time to failure was determined when the specimen broke or deflected on the scale numerically equal to three times the thickness of the test specimen on the leading edge of the deflection scale.

It was found desirable to run several preliminary specimens prior to the formal test in order to bracket failure time or gain experience with new materials. A minimum of four specimens of each material were tested and the failure time was recorded as an average of these four tests.

6. CALIBRATION OF APPARATUS

An initial series of thirty tests was conducted with 1/2 inch (12.7 mm) Type X and 1/2 inch (12.7 mm) regular gypsum wallboard to determine the weight factor for the cantilevered end. The primary purpose of the weight is to accelerate the test. Once the 150 gram weight proved satisfactory for 1/2 inch material, the other weights were established in direct proportion to the thickness being tested.

Concurrent calibration of the test apparatus included detailed measurements of the air and gas flow rates and flame temperature profiles. (see fig. 6) Calibrated flowmeters were used to establish the flow rates for the air and fuel in SCFH.

Due to the importance of the thermal exposure, extensive measurements were taken of the flame temperature. A two channel recorder was used. Temperature profiles were recorded with two different size chromel-alumel thermocouples; one, a very sensitive 36 gage, and the other, a slower response 20 gage. Measurements were made throughout the luminous region of the flames without a sample present. Eight points were used to determine an average flame temperature. The locations for these points are detailed isometrically in figure 5.

The $1,780 \pm 25^{\circ}\text{F}$ ($971 \pm 14^{\circ}\text{C}$) effective flame temperature has been established as the optimum operating range for the apparatus. The impinging flames were determined to be borderline turbulent thru calculation of the Reynolds number [6].

7. DISCUSSION OF RESULTS WITH PRESENT APPARATUS

In order to achieve an industry wide fire endurance rating, six different manufacturers' products are normally used in the construction of the test wall or ceiling membrane for each industry sponsored ASTM E-119 test. Sample materials from six different manufacturers with the identical production coding as that which had been used successfully to achieve one and two hour endurance ratings were acquired from a testing laboratory to correlate this test method with the ASTM E-119. The results of a formal series of tests are presented in the Data Sections (8.1., 8.2. and 8.3.).

The data¹ are also plotted on the charts shown as figures 7 and 8 along with results accumulated during the development and calibration of the test. Additional materials, both regular and Type X, were purchased from local suppliers to compare products from different plants available on the open market. In addition, laboratory formulations were prepared having varying additives to access the sensitivity of the instrument and were ranked correctly. The letter designation in figures 7 and 8 correspond to the code letters for materials listed in the tables (section 8).

A summary of these data offers several conclusions as to the validity of this test method. Analysis of data shows that the average coefficient of variation for a single test of one type of material from a given manufacturer is $\pm 8\%$. Further, the identification of an "intermediate" formula which allows for the addition of small quantities of glass fiber into the regular formula for strength can be screened by this method where other tests have indicated such formulas would qualify as Type X.

There are essentially four classifications of gypsum wallboards that can be determined by this test method as follows:

1. Regular gypsum wallboard - Regular core formula as manufactured to ASTM C-36 Standard Specifications.
2. Intermediate formulations - Regular with small quantities of glass fiber or gypsum boards with insufficient fiber content (probably less than 4 pounds per MSF) or short lengths of glass fibers (less and 3/8 inch) to qualify as Type X.
3. Type X - Manufactured in accordance with ASTM C-36 Standard Specifications for extra fire resistance.

¹Each point in the figures is based on the mean of at least 4 tests of each specimen.

□ REGULAR FORMULA

○ TYPE X FORMULA

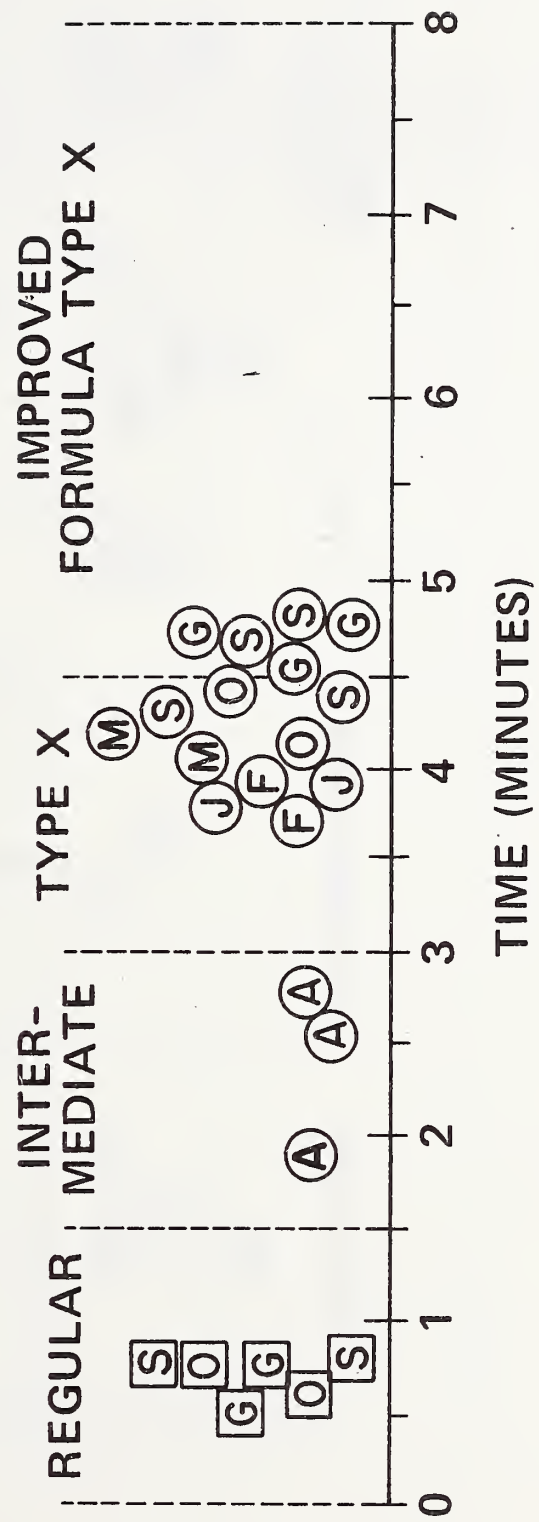

1/2" THICK MATERIALS

Figure 7. Average Time to Failure for 1/2-inch Thick Specimens

REGULAR FORMULA



TYPE X FORMULA



5/8" THICK MATERIALS

Figure 8. Average Time to Failure for 5/8-inch Thick Specimens

4. Improved Formula Type X - Meets the ASTM requirements for Type X, but contains additional quantities of glass fiber and/or other additives to improve the performance.

Over 400 tests have been conducted during the development and refinement of this test procedure. In addition, the apparatus has been in operation continually for more than six hours on two occasions to determine its serviceability.

8. DATA SECTION

8.1. Test Results of 1/2" Type X and Improved Formula Type X

Source	Specimen Number	Thickness	Specimen Wt. (grams)	Time to Failure min:sec	Average Time to Failure
J.	1	1/2"	199	3:46	3:46
	2	1/2"	194	3:49	
	3	1/2"	195	3:45	
	4	1/2"	194	3:45	
G.	1	1/2"	203	4:44	4:38
	2	1/2"	202	4:34	
	3	1/2"	204	4:41	
	4	1/2"	206	4:34	
M.	1	1/2"	202	4:14	4:13
	2	1/2"	202	4:16	
	3	1/2"	205	4:10	
	4	1/2"	205	4:12	
F.	1	1/2"	192	3:38	3:37
	2	1/2"	184	3:34	
	3	1/2"	185	3:39	
	4	1/2"	186	3:37	
J.	1	1/2"	219	3:57	3:57
	2	1/2"	217	3:55	
	3	1/2"	215	4:01	
	4	1/2"	218	3:56	
M.	1	1/2"	202	4:21	4:27
	2	1/2"	208	4:25	
	3	1/2"	207	4:26	
	4	1/2"	207	4:26	
O.	1	1/2"	196	4:05	4:04
	2	1/2"	194	4:00	
	3	1/2"	191	4:04	
	4	1/2"	190	4:07	
S.	1	1/2"	208	4:42	4:43
	2	1/2"	212	4:47	
	3	1/2"	207	4:35	
	4	1/2"	216	4:48	
S.	1	1/2"	215	4:49	4:47
	2	1/2"	213	4:47	
	3	1/2"	209	4:45	
	4	1/2"	213	4:47	
F.	1	1/2"	186	4:03	3:59
	2	1/2"	184	3:56	
	3	1/2"	182	3:59	
	4	1/2"	184	3:57	

8.2. Test Results of 5/8" Type X and Improved Formula Type X

Source	Specimen Number	Thickness	Specimen Wt. (grams)	Time to Failure min:sec	Average Time to Failure
S.	1	5/8"	256	4:43	4:39
	2	5/8"	250	4:22	
	3	5/8"	251	4:45	
	4	5/8"	246	4:49	
G.	1	5/8"	243	7:39	7:46
	2	5/8"	244	7:51	
	3	5/8"	246	7:36	
	4	5/8"	251	7:58	
F.	1	5/8"	252	5:57	5:41
	2	5/8"	245	5:38	
	3	5/8"	245	5:32	
	4	5/8"	244	5:37	
F.	1	5/8"	243	5:38	5:45
	2	5/8"	243	5:47	
	3	5/8"	242	5:50	
	4	5/8"	244	5:44	
O.	1	5/8"	257	6:37	6:17
	2	5/8"	253	6:05	
	3	5/8"	250	6:11	
	4	5/8"	251	6:13	
S.	1	5/8"	250	4:26	4:38
	2	5/8"	245	4:31	
	3	5/8"	249	4:43	
	4	5/8"	249	4:52	
J.	1	5/8"	237	5:08	5:02
	2	5/8"	236	5:07	
	3	5/8"	238	5:03	
	4	5/8"	242	4:49	
J.	1	5/8"	261	4:47	4:41
	2	5/8"	261	4:50	
	3	5/8"	257	4:45	
	4	5/8"	257	4:22	
M.	1	5/8"	248	5:24	5:26
	2	5/8"	240	5:12	
	3	5/8"	242	5:29	
	4	5/8"	241	5:40	
M.	1	5/8"	244	5:36	5:34
	2	5/8"	242	5:27	
	3	5/8"	241	5:38	
	4	5/8"	244	5:36	

8.3. Test Results of 1/2" and 5/8" Regular Formula

Source	Specimen Number	Thickness	Specimen Wt. (grams)	Time to Failure min:sec	Average Time to Failure
S.	1	1/2"	181	0:29	0:33
	2	1/2"	184	0:33	
	3	1/2"	182	0:30	
	4	1/2"	190	0:39	
O.	1	1/2"	184	0:31	0:32
	2	1/2"	180	0:30	
	3	1/2"	183	0:33	
	4	1/2"	186	0:35	
G.	1	1/2"	193	0:35	0:42
	2	1/2"	195	0:44	
	3	1/2"	194	0:48	
	4	1/2"	190	0:41	
S.	1	1/2"	187	0:49	0:45
	2	1/2"	184	0:36	
	3	1/2"	188	0:51	
	4	1/2"	189	0:46	
O.	1	1/2"	181	0:37	0:37
	2	1/2"	181	0:41	
	3	1/2"	183	0:34	
	4	1/2"	180	0:35	
G.	1	1/2"	193	0:49	0:46
	2	1/2"	190	0:44	
	3	1/2"	194	0:44	
	4	1/2"	193	0:47	
G.	1	5/8"	246	0:59	1:21
	2	5/8"	248	1:06	
	3	5/8"	244	1:37	
	4	5/8"	243	1:43	
G.	1	5/8"	243	1:27	1:29
	2	5/8"	244	1:34	
	3	5/8"	248	1:38	
	4	5/8"	244	1:17	
M.	1	5/8"	214	1:09	1:03
	2	5/8"	215	0:58	
	3	5/8"	210	1:00	
	4	5/8"	212	1:03	
O.	1	5/8"	230	1:08	1:09
	2	5/8"	222	1:12	
	3	5/8"	226	1:05	
	4	5/8"	228	1:10	

9. CONCLUSIONS

The bench test for Type X core described in this report has been judged suitable based on the results of tests during its early stages of development. Not only will it distinguish between variations in core formulations, but it is sensitive to different concentrations of glass fiber as well as fiber length. The test seems unaffected by variations within nominal manufacturing tolerances in caliper, weight and density. The test method clearly satisfies each of the initial goals set for its development. Correlation is evident between this test method and ASTM E-119 in the thermal levels, flexural stressing and identification of those materials that are identical in performance to those that have performed satisfactorily in the full-scale tests.

Although designed essentially as a quality control test, the test procedure also has merit as a research tool for the evaluation of changes in core formulations.

10. RECOMMENDATIONS FOR FUTURE WORK

Improvements of a convenience nature may be introduced and research with other fuel sources such as propane or oxyacetylene may refine the operation of this apparatus. It may also be useful to investigate the effect of the many different surface finish materials that utilize gypsum wallboard as a substrate.

Although the test apparatus appears to work as intended in its present state of development, the proof will lie in the fabrication of duplicate equipment and achieving the same results. It is, therefore, desirable that other laboratories reproduce the apparatus in order to evaluate results through interlaboratory round-robin testing.

APPENDIX A. THERMAL VALUES OF GYPSUM

The following data are recommended for use in calculating the heat transmission coefficients or "U" values for gypsum wallboard products used in construction systems:

Thermal Conductivity Values

Thickness	Conductance "C" Btu/ft ² sec	Resistance "R" Btu/ft ² sec
3/8" (9.525 mm)	3.00	0.33
1/2" (12.7 mm)	2.36	0.42
5/8" (15.9 mm)	1.88	0.53
1" (25.4 mm)	1.20	0.85

APPENDIX B. SI CONVERSION FACTORS

The conversion factors listed in this appendix may be used to convert the U.S. customary units to the International System of Metric Units (SI). For further assistance refer to ASTM E-380 or the ASTM Standard Metric Practice Guide. The conversion factors are as follows:

$$1 \text{ inch} = 2.54 \text{ cm (25.4 mm)}$$

$$1 \text{ foot} = 0.305 \text{ m}$$

$$68^\circ\text{F} = 20^\circ\text{C}$$

$$212^\circ\text{F} = 100^\circ\text{C}$$

$$800^\circ\text{F} = 427^\circ\text{C}$$

$$1,780^\circ\text{F} = 971^\circ\text{C}$$

$$1 \text{ Btu}/(\text{ft}^2 \text{ sec}) = 1.14 \text{ W}/\text{cm}^2$$

REFERENCES

- [1] U.S. Bureau of Mines, Mineral Industry Survey, 1972 and through 2nd quarter 1973..
- [2] Annual Book of ASTM Standards, Part 14, American Society of Testing and Materials, Philadelphia, Pa., 568-586 (1973).
- [3] Annual Book of ASTM Standards, Part 9, American Society of Testing and Materials, Philadelphia, Pa., 31-32 (1973).
- [4] Abbey, C. E., Type X Wallboard, What It Is and Where and When It Originated, Southern Building Magazine (Apr. 1966).
- [5] Annual Book of ASTM Standards, Part 9, American Society of Testing and Materials, Philadelphia, Pa., 347-352 (1973).
- [6] Kreith, F., Principles of Heat Transfer, International Textbook Co., 331-344 and 366-379 (1968).

U.S. DEPT. OF COMM. BIBLIOGRAPHIC DATA SHEET	1. PUBLICATION OR REPORT NO. NBSIR -	2. Gov't Accession No.	3. Recipient's Accession No.
4. TITLE AND SUBTITLE Development of a Bench Test For Type X Core Gypsum Board		5. Publication Date	
7. AUTHOR(S) J. L. Houser		8. Performing Organ. Report No.	
9. PERFORMING ORGANIZATION NAME AND ADDRESS NATIONAL BUREAU OF STANDARDS DEPARTMENT OF COMMERCE WASHINGTON, D.C. 20234		10. Project/Task/Work Unit No. 4906571	
12. Sponsoring Organization Name and Complete Address (Street, City, State, ZIP) same as No. 9		13. Type of Report & Period Covered Final Report	
15. SUPPLEMENTARY NOTES		14. Sponsoring Agency Code	
<p>16. ABSTRACT (A 200-word or less factual summary of most significant information. If document includes a significant bibliography or literature survey, mention it here.)</p> <p>This paper describes the development of a test method for determining that the core material in a gypsum board sample qualifies as Type X. A 2 inch (5.08 cm) by 16 inch (40.64 cm) specimen is flexurally stressed during the test by suspending a weight from the cantilevered end of the test sample. The specimen is swiveled into the center of a two burner turbulent flame at an average temperature of 1,780°F (971°C). The burners are positioned from above and below. The test is terminated when the specimen either breaks or deflects through an arc three times the specimen thickness. Results show this method to be repeatable with a coefficient of variation equal to ± 8 percent for a given type of material from a single manufacturer.</p>			
<p>17. KEY WORDS (six to twelve entries; alphabetical order; capitalize only the first letter of the first key word unless a proper name; separated by semicolons) Building codes; construction materials; fire endurance ratings; fire tests; gypsum.</p>			
<p>18. AVAILABILITY <input checked="" type="checkbox"/> Unlimited</p> <p><input type="checkbox"/> For Official Distribution. Do Not Release to NTIS</p> <p><input type="checkbox"/> Order From Sup. of Doc., U.S. Government Printing Office Washington, D.C. 20402, SD Cat. No. C13</p> <p><input type="checkbox"/> Order From National Technical Information Service (NTIS) Springfield, Virginia 22151</p>		<p>19. SECURITY CLASS (THIS REPORT)</p> <p>UNCLASSIFIED</p>	<p>21. NO. OF PAGES</p> <p>22</p>
		<p>20. SECURITY CLASS (THIS PAGE)</p> <p>UNCLASSIFIED</p>	<p>22. Price</p>

