

NBSIR 74-574

NBSLD, Computer Program for Heating and Cooling Loads in Buildings

T. Kusuda

Center for Building Technology
Institute for Applied Technology
National Bureau of Standards
Washington, D. C. 20234

November 1974

Final Report

Prepared for
Housing and Urban Development
451 7th Street, S. W.
Washington, D. C. 20410

NBSIR 74-574

**NBSLD, COMPUTER PROGRAM FOR
HEATING AND COOLING LOADS IN
BUILDINGS**

T. Kusuda

Center for Building Technology
Institute for Applied Technology
National Bureau of Standards
Washington, D. C. 20234

November 1974

Final Report

This report will be published in
May 1975 as a National Bureau of
Standards Building Science Series
Publication.

Prepared for
Housing and Urban Development
451 7th Street, S. W.
Washington, D. C. 20410



U. S. DEPARTMENT OF COMMERCE, Frederick B. Dent, Secretary

NATIONAL BUREAU OF STANDARDS, Richard W. Roberts, Director

U. S. DEPARTMENT OF COMMERCE

NBSLD

Computer Program for Heating and Cooling Loads in Buildings

National Bureau of Standards

Tamami Kusuda
Thermal Engineering Systems Section
Building Environment Division
Center for Building Technology
Institute for Applied Technology
National Bureau of Standards

Preface

This document comprises the engineering manual for the computer program called the National Bureau of Standards Load Determination Program hereafter referred to as NBSLD. Presented herein are the algorithms for the exact calculation methodology that was developed in the Thermal Engineering Systems Section of the National Bureau of Standards to determine accurate heating and cooling loads for the thermal design of buildings. NBSLD, which is based upon the methodologies presented in this publication, has been available for some time for the purpose of evaluating various building constructions and systems. The program was originally developed as a research tool because none of the commercially available programs had features or the sophistication to enable the evaluation of unconventional designs. NBSLD has been an indispensable tool for studies of numerous HUD housing systems, constructions of the Defense Department and the General Services Administration where non-conventional design conditions had to be evaluated.

As the existence and the capability of NBSLD became known, numerous requests were made to NBS to release the program for public use. This publication is in response to that request. Hopefully, engineers will be able to adopt some of the computational schemes described in this publication to their own programs. A complete Fortran program is attached, although NBS does not claim that the program is optimum from the standpoint of the computer memory allocation or computational economy. It will take additional improvements before the program becomes optimum from those viewpoints. The program documentation is being made available at this time so

engineers can use it for accurate load determination as they seek to conserve energy through improved thermal design of buildings. The author would appreciate receiving reader's comments with respect to the accuracy of this text.

It should be mentioned that some of the subroutine algorithms listed in this publication have already been published in the well known ASHRAE booklet entitled "Procedure for Determining Heating and Cooling Loads for Computerized Energy Calculations". These subroutines were compiled by the author who served as the chairman of the Subcommittee on Heating and Cooling Load Calculations of the ASHRAE Task Group on Energy Requirements for Heating and Cooling of Buildings. The ASHRAE publication, however, contains several critical errors, which have been corrected for use in this volume.

The author is greatly indebted to Dr. J. E. Hill for this thorough editing of the text, to Mrs. Sharon D. Crampton for her skill and patience in typing the manuscript and to Mr. F. J. Powell for his encouragement to produce the document.

Table of Contents

| | Page |
|---|------|
| 1. Introduction | 1 |
| 2. Fundamentals of Heating and Cooling Load Calculation . . . | 3 |
| 2.1 A Rigorous Method of Calculating Heating and Cooling Loads | 5 |
| 2.2 Approximate Methods of Calculating Heating and Cooling Loads | 9 |
| 3. Unique Features of NBS Load Calculation Computer Program . . | 15 |
| 4. General Description of NBSLD Subroutines | 22 |
| 5. NBSLD Logic Diagram | 31 |
| 6. References | 33 |
| 7. Appendix A - ASHRAE Task Group Subroutine Algorithms | |
| CLIMAT - Weather data processing | 1a |
| SUN - Basic solar position data | 6a |
| CCF - Cloud cover factor | 15a |
| SOLAD - Solar radiation intensity | 18a |
| TAR - Glass transmission and absorption | 22a |
| SHG - Solar heat gain through a window | 29a |
| SHADOW - Sunlit area calculations | 31a |
| FIJ - Radiation heat transfer exchange factors | 48a |
| FI - Interior surface heat transfer coefficients | 64a |
| FO - Outside surface heat transfer coefficients | 65a |
| ACR - Air cavity heat transfer coefficients | 68a |
| XYZ - Conduction transfer functions | 71a |
| HEATW - Heat conduction through exposed surfaces | 79a |
| SCHEDULE - Internal heat generation | 86a |
| Fundamentals of Room Temperature and Cooling (Heating) | |
| Load Calculations | 89a |
| RMTMP - Exact room load calculation | 94a |
| ATTIC - Exact attic temperature calculation | 108a |
| IHG - Instantaneous heat gain concept | 109a |
| HLC - Heating/cooling load calculation by the transfer function method | 115a |
| RMRT - Transfer functions for the room temperature cal- culations | 122a |
| HEXT - Heat extraction rate calculation | 128a |
| INFIL - Building air exchange calculation | 129a |

Miscellaneous routines

| | |
|--|------|
| DST - Daylight saving time indicator | 144a |
| WKDAY - Day of week identifier | 145a |
| HOLIDAY - U. S. Holiday identifier | 149a |
| PSY - Psychrometric calculations | 150a |

8. Appendix B - Weighting Factor Method for Calculating Heating and Cooling Loads and Space Temperature
9. Appendix C - NBSLD Data Forms
10. Appendix D - NBSLD Fortran Listing
11. ASHRAE Psychrometric Chart

NBSLD

National Bureau of Standards Heating and Cooling
Load Determination Program

T. Kusuda
Thermal Engineering Systems Section
Building Environment Division
Center for Building Technology, IAT

ABSTRACT

A comprehensive computer program called NBSLD, the National Bureau of Standards Load Determination program, has been developed at NBS to reflect the time change of the many building parameters which are pertinent to accurate estimation of energy usage for heating and cooling. Current status of heating and cooling load techniques is reviewed. Of general interest are unique features of NBSLD which are not available in existing computer programs. A summary of various subroutines of NBSLD is given along with the detailed procedures for them. These subroutines constitute the recommended subroutine algorithms of the ASHRAE Task Group on Energy Requirements. Complete Fortran listing of NBSLD and data preparation forms are given for those who wish to use the program. The NBSLD computation is on the basis of the detailed solution of simultaneous heat balance equations at all the interior surfaces of a room or space. Transient heat conduction through exterior walls and the interior structures is handled by using conduction transfer functions. The use of heat balance equations, although time consuming in calculation, can avoid the vagueness and uncertainties inherent in the more popularly used weighting factor approach.

In addition, it is more accurate for a specific building design.

Key Words: ASHRAE Task Group on Energy Requirements;
conduction transfer functions; heating and
cooling load; National Bureau of Standards
Heating and Cooling Load Computer Program

1. Introduction

Numerous studies in recent years on the matter of energy shortage lead one to believe that the U. S. demand for energy will very shortly outstrip her power generating capacity and fossil fuel supply. According to a recent report of the Stanford Research Institute^{1/}, space heating and cooling for residential and commercial buildings amounts to approximately 20% of the total energy consumed in the United States, which was 60 trillion Btu per year in 1968. Moreover, recent and frequent blackouts and brownouts in the east coast region of the United States are good indications that the electric power demand for summer air conditioning exceeds for certain times, the capability of supply and distribution by the power companies.

It is in this context that new and accurate methodology for energy calculations is most crucial for the design and analysis of the performance of space heating and cooling systems. This is especially true in view of the fact that the current load calculation procedures could lead to the over-design of heating and cooling equipment and imprudent use of energy.

It is generally accepted that buildings can be designed to be energy effective if their thermal insulation is increased; window size, air leakage, and lighting levels decreased; shading devices properly installed; heating and cooling systems adequately designed, installed, and maintained; and their heat storage capability most fully utilized. These energy saving features, however, must be considered with reference to numerous constraints, such as added costs for material, construction and maintenance,

conformance to local building codes, occupancy life styles, aesthetics, construction practices, and availability of equipment.

In spite of these constraints, there is sufficient engineering information and technical basis that exist today to warrant extensive studies on various design alternatives for heating and cooling the building to minimize the wasteful use of energy. Design and operation of heating and cooling systems based upon conventional steady-state calculations, for example, usually result in oversizing of equipment and overheating or cooling of the space to be controlled. An over-design system usually operates at lower efficiency and needs more material (consequently more energy) to produce it, thus creating a vicious cycle.

One effective way to design the heating and cooling systems which is optimum from the standpoint of energy consumption, peak power demand and many practical constraints mentioned above, is to study the building thermal performance by using accurate simulations. Because the use of computer simulations make it possible to evaluate the sensitivity of various design alternatives on the net energy usage, they can be a very effective tool in the design process. In order for such design studies to be conducted on the computer however, the computer program to be used should be very comprehensive and should indicate the proper response to the change of the many parameters which are pertinent to energy usage. The intent of this document is to present a more detailed calculation methodology than is generally used to make it possible for engineers to reduce the area of approximation, where this is considered desirable, by a rigorous computer simulation of building systems, which consider and take into account most of the variables that affect the building and

system operation.

Refined and sophisticated calculation procedures unfortunately are both time consuming and expensive. Without the use of advanced computer methods, they are literally impossible. The development of such calculation procedures can only be justified on the basis that the more accurate calculation will result in overall savings in energy usage and owning and operating costs and consequently in total life cycle cost due to better design of the building systems, more precise sizing of the equipment, and more carefully controlled operation of the heating and cooling system. There are many indications that such a justification is well warranted.

2. Fundamentals of Heating and Cooling Load Calculation

Calculation of the energy requirements of the heating and cooling system of a building involves three major steps which may be carried out simply to achieve approximate results, or with increasing degrees of complexity and sophistication as more accurate and more refined determination of system performance is required. First, is the calculation of heat loss or heat gain to the space which is heated or cooled. Second, is the determination of the heating and cooling load imposed on the system. Third, is the calculation of the energy input to all of the system components to satisfy that load.

The ASHRAE Handbook of Fundamentals^{2/} contains the basic information whereby the heating and cooling load of a building may be calculated. Customarily such load calculations are made for the so-called "design conditions" for sizing the equipment and developing the design of the heating and cooling system. However, the "design conditions" normally exist only

for a very few hours, if at all, during a heating or cooling season. Consequently, the actual day-by-day and hour-by-hour heating and cooling load for energy consumption is quite different from that for the design condition. Thus the heating and cooling load calculation for the purpose of estimating "energy requirements" must reflect the actual weather conditions rather than a design condition.

Various methods have been developed in the past such as the "degree day" method or "bin" method for proportioning the design load, to obtain approximate monthly, daily, or hourly loads and consequently provide a basis for determining energy requirements. Insofar as such methods are based on valid approximation procedures and checked against actual operating experience, they provide the base for simplified determination of energy requirements acceptable for the needs of most engineers.

In this section a review of the rigorous methods of calculating heating and cooling loads by means of solving heat balance equations at all the interior surfaces of a room or space is given. Also described are approximate methods in which weighting factors are developed after the heat balance equations have been solved for one set of conditions. The NBSLD calculations follow the rigorous method while the ASHRAE Task Group procedures use the weighting factor method.

In NBSLD the transient heat conduction through exterior walls of the room or space is handled by using conduction transfer functions. The use of heat balance equations at the interior surfaces, although more time consuming, can avoid the vagueness and uncertainties inherent in the weighting factor approach. In addition, it is more accurate for a specific building design.

2.1 A Rigorous Method of Calculating Heating and Cooling Loads

A cooling (heating) load is of course the amount of energy that is transferred to (from) the room and simultaneously removed (added) by the conditioning equipment at any given time of interest. To calculate this quantity directly requires a rather laborious solution of energy balance equations involving the room air, surrounding walls, infiltrating and ventilation air, and internal energy sources. The principle of calculation can be demonstrated by considering a fictitious space that is enclosed by 4 walls, a ceiling and floor, and having infiltration air as well as normal internal energy sources. The six equations that govern energy exchange at each inside surface at a given time t are:

$$q_{i,t} = h_{ci} (t_{a,t} - t_{i,t}) + \sum_{\substack{j=1 \\ j \neq i}}^m g_{ij} (t_{j,t} - t_{i,t}) + RS_{i,t} + RL_{i,t} + RE_{i,t}$$

for $i = 1, 2, 3, 4, 5, 6$

where

m = number of surfaces in the space

$q_{i,t}$ = rate of heat conducted into surface i at the inside surface at time t

h_{ci} = convective heat transfer coefficient at interior surface i

g_{ij} = radiation heat transfer factor between interior surface i and interior surface j

$t_{a,t}$ = inside air temperature at time t

- $t_{i,t}$ = average temperature of interior surface i at time t
 $t_{j,t}$ = average temperature of interior surface j at time t
 $RS_{i,t}$ = rate of solar energy coming through the windows and absorbed by surface i at time t
 $RL_{i,t}$ = rate of heat radiated from the lights and absorbed by surface i at time t
 $RE_{i,t}$ = rate of heat radiated from equipment and occupants and absorbed by surface i at time t

The equations governing conduction within the six slabs cannot be solved independent of the above equations since the energy exchanges occurring within the room affect the inside surface conditions which in turn affect the internal conduction. Consequently, one is faced with solving six equations simultaneously with the governing equations of conduction within six slabs in order to calculate the cooling load at time of interest ($Q_{L,t}$) which would be given by:

$$\begin{aligned}
 Q_{L,t} = & \sum_{i=1}^6 h_{ci} (t_{i,t} - t_{a,t}) + \rho C G_{L,t} (t_{o,t} - t_{a,t}) \\
 & + \rho C G_{v,t} (t_{v,t} - t_{a,t}) + RS_{a,t} + RL_{a,t} + RE_{a,t}
 \end{aligned}$$

where

- ρ = air density
 C = air specific heat
 $G_{L,t}$ = mass flow rate of outdoor air infiltrating into the space at time t
 $t_{o,t}$ = outdoor air temperature at time t

- $G_{v,t}$ = mass rate of flow of ventilation air at time t
 $t_{v,t}$ = ventilation air temperature at time t
 $RS_{a,t}$ = rate of solar heat coming through the windows and
 convected into the room air at time t
 $RL_{a,t}$ = rate of heat from the lights convected into the room
 air at time t
 $RE_{a,t}$ = rate of heat from equipment and occupants and convected
 into the room air at time t

A rigorous approach such as this for calculating cooling load would be practically impossible if it were not for the speed at which such computations can be done by modern digital computers. Even so, there are very few computer programs in use today where instantaneous cooling loads are calculated in this exact manner. The concept, however, has been presented previously by Stephenson and Mitalas^{3/}, and by Buchberg^{4/}.

Not to be ignored is the effect of air temperature deviation from some prescribed set point. This set point is the temperature for which the cooling (heating) load calculation is made and for which the design capacity of the cooling (heating) apparatus is usually selected. A recent study by Mitalas and Stephenson^{5/} shows that actual heat extracted from the space is considerably smaller than the cooling load calculated on the basis of a constant space temperature. This is due to the thermal storage effect of the building structure and internal furnishings. Figure 1 shows a result from that study and as can be seen, the calculated cooling load peaks at values considerably higher than the measured heat extraction rate.

75
50
25
0

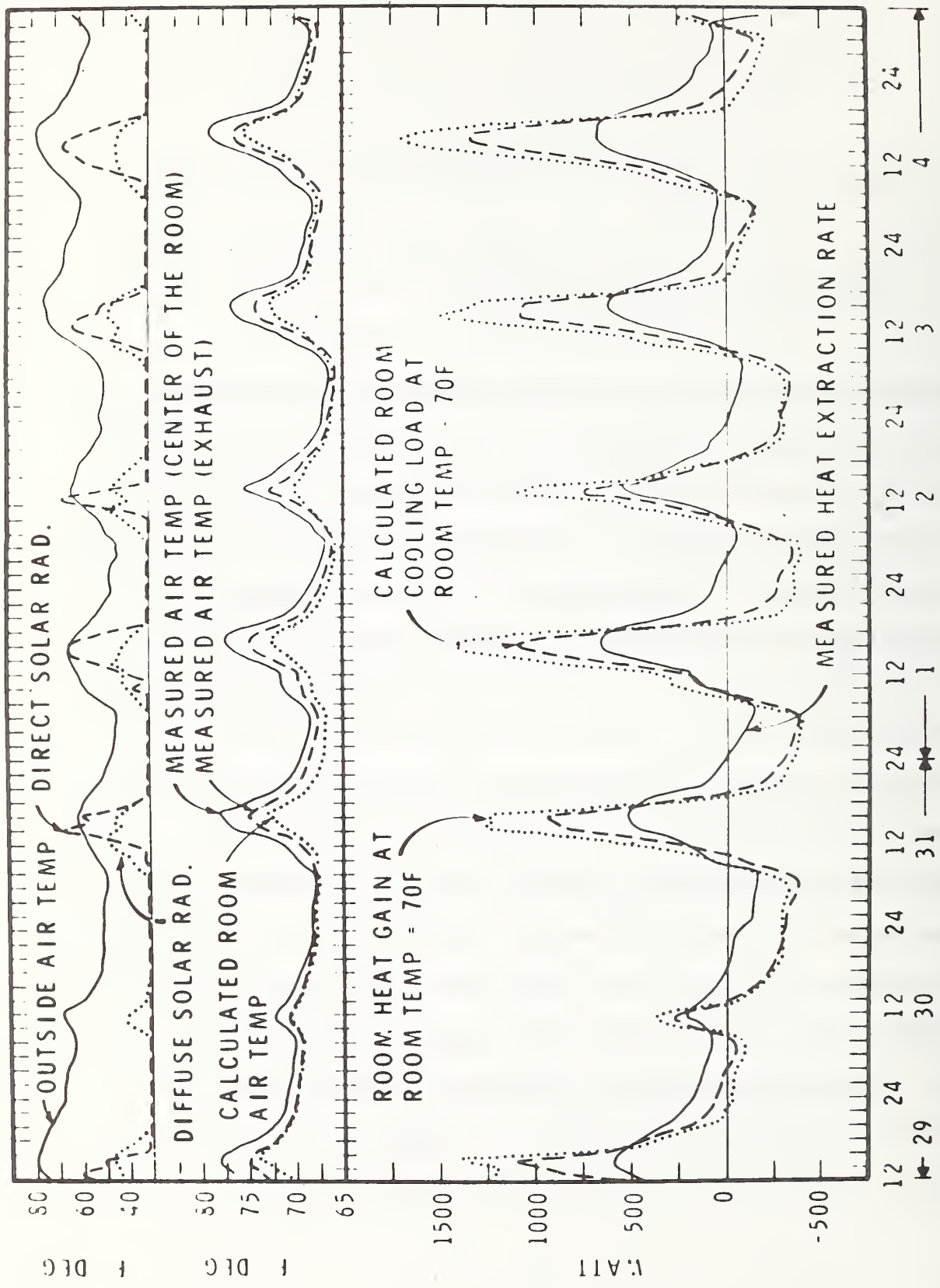

SEPT 67

AUG 67

TIME

Figure 1 Measured and Calculated Thermal Performance in an Ottawa Office Building (Reference 4)

2.2 Approximate Methods of Calculating Heating and Cooling Loads

Since the exact solution technique is extremely time consuming especially for the calculations done for a period of 8760 hours (one year), the ASHRAE Task Group on Energy Requirements recommends a transfer function concept to simplify the calculation procedure. The transfer function concept was first introduced by Mitalas and Stephenson^{3/} using what they called room thermal response factors. Their procedure is as follows: the room surface temperatures and cooling or heating load are first calculated by a rigorous method as described in the previous section for several typical constructions representing offices, schools and dwellings of heavy, medium and lightweight construction. In these calculations, the components such as solar heat gain, conduction heat gain, or the heat gain from the lighting, equipment, and occupants are simulated by pulses of unit strength. The transfer functions are then calculated as numerical constants which represent the cooling load (or heating) corresponding to the input excitation pulses. Once these transfer functions are determined for a number of typical constructions, they are assumed to be independent of input pulses and the determination of cooling loads (or heating) is possible without resorting to the rigorous calculations. The calculation required is, instead, simple multiplication of the transfer functions by a time-series representation of heat gain and the subsequent summation of these products, which can be carried out on a small computer with little effort.

Another way to shorten the computational effort for energy calculations is to determine regression parameters by fitting a simple algebraic equation to the results of rigorous calculations, which had been obtained not for an entire year but for a limited period in the year, such as for the months of January and/or July. Once this regression equation is determined with sufficient accuracy, an energy estimate is made by superimposing the weather conditions of the other months onto the relationships just determined.

An example of this approach is illustrated in Figure 2, which depicts the daily total heating and cooling load plotted against the daily average outdoor air temperature. This plot is a result of a lengthy rigorous calculation performed on a typical apartment in Jersey City using the annual hourly weather conditions that occurred in 1949. The straight lines superimposed on the figures were the least square regression lines that best fit the calculated loads for January and July. It was clear from this figure that the exact calculations for other months would not be necessary, at least for the purpose of determining daily loads, since the regression relationship determined from the January and July calculations were sufficiently accurate that they could be extrapolated to the remainder of the year.

Depending upon the type of building and its heating and cooling system, a good correlation such as illustrated in Figure 2 may not be possible. Figure 3 shows, for example, a similar plot for a test office building whose heating and cooling load were measured in a research project

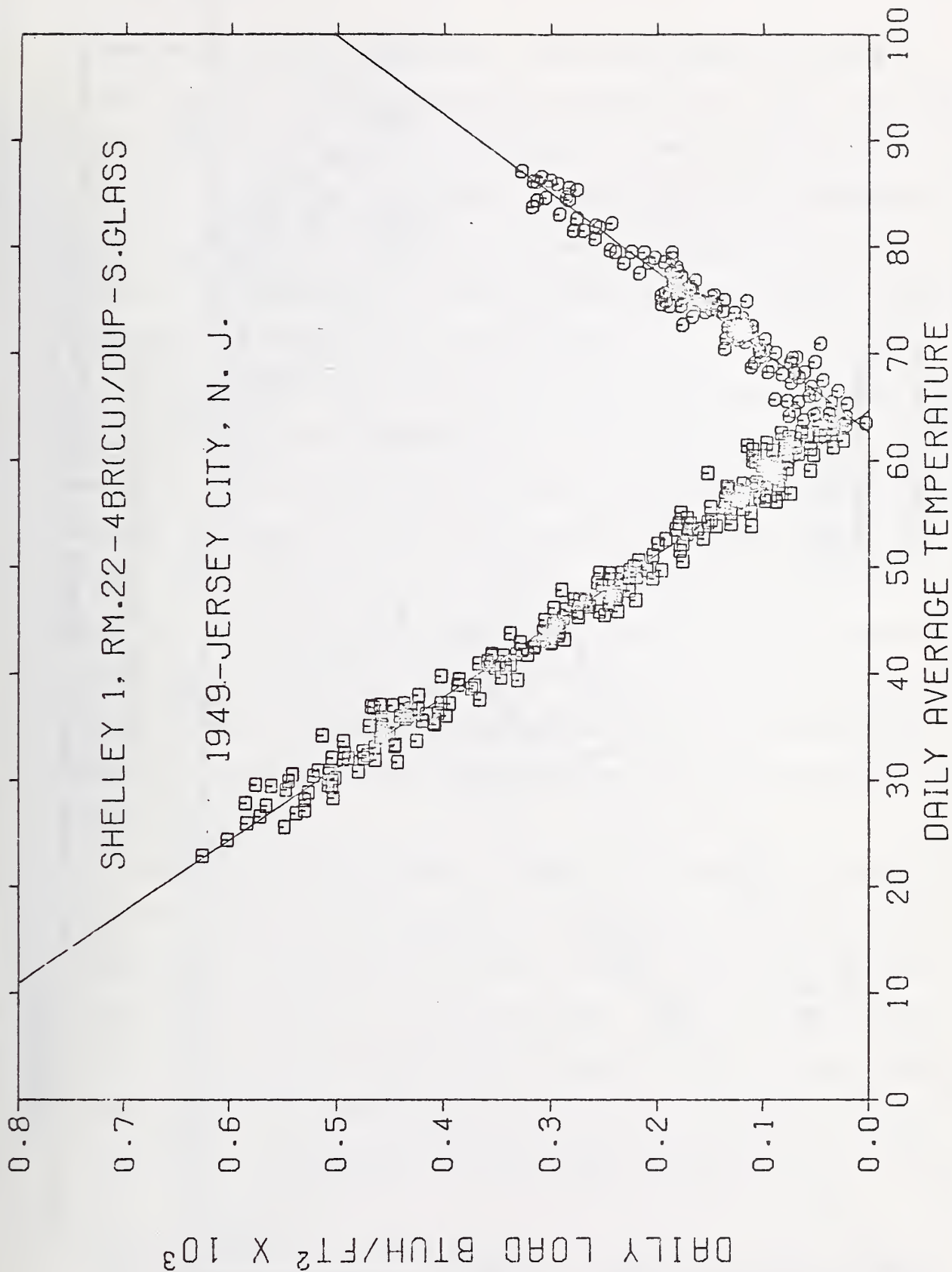

Figure 2 Calculated Daily Total Thermal Loads of a Jersey City Apartment Plotted Against Daily Average Temperatures

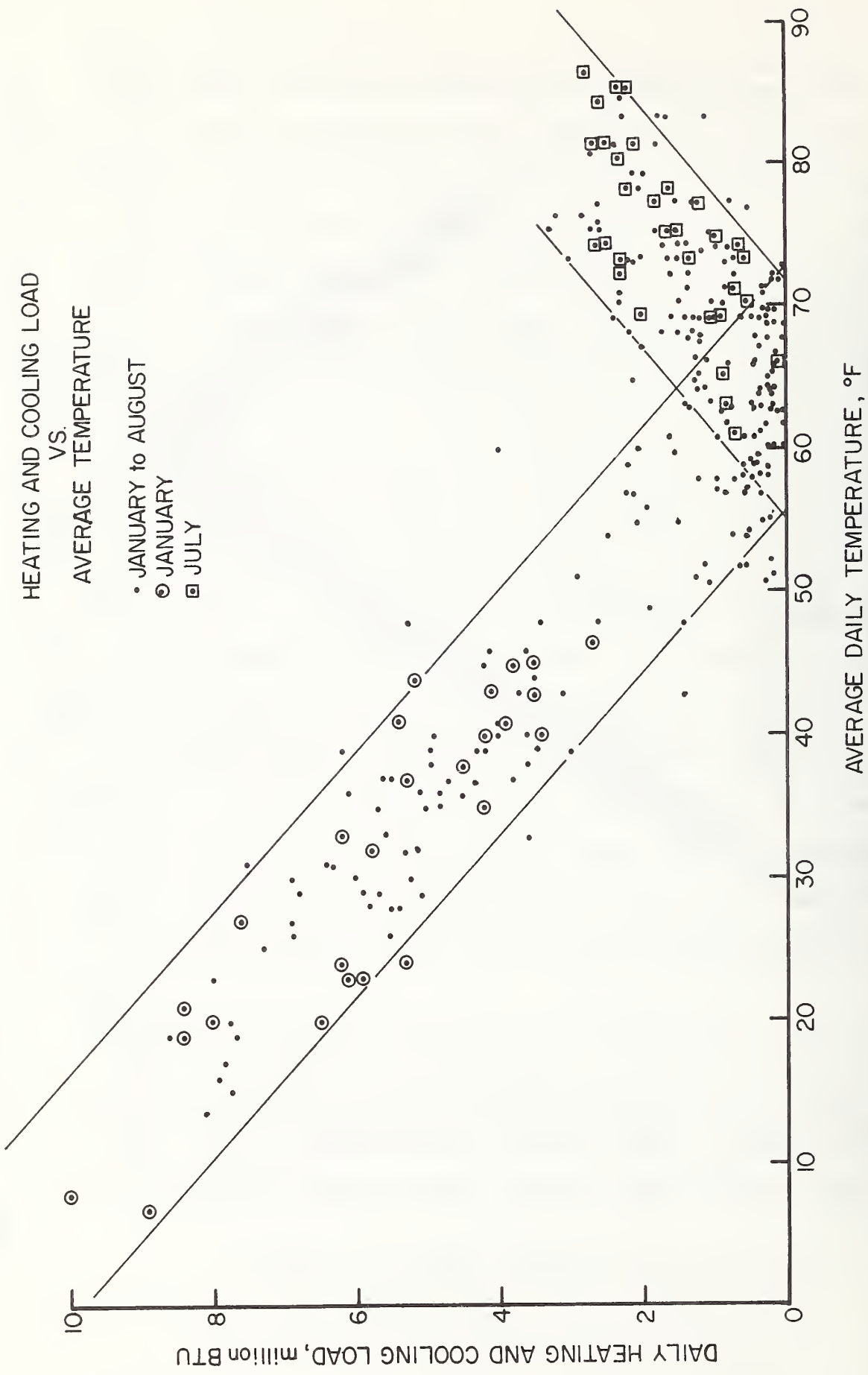

Figure 3 Measured Daily Total Thermal Loads of a Columbus Law Building Plotted Against Daily Average Temperatures

conducted by Ohio State University. The scatter appears considerably larger than the calculated relationship obtained in the Jersey City study. It is obvious that the thermal performance of commercial buildings are affected in a large way by the manner in which internal heat is generated in addition to the normal dependence on outdoor temperature. The inclusion of one or more additional statistical parameters dealing with these internal heat gains should improve the correlation.

Recently one additional method of predicting the heating and/or cooling load or the indoor temperature as a result of the excitation parameters such as outdoor temperature, solar radiation and internal heat generation has been demonstrated by Kusuda and Tsuchiya^{6/} and further expanded by Kimura and Ishino^{7/}. The method uses the concept of equivalent thermal mass of a building and attempts to fit the observed input and output data into a linear differential equation. The initial results are promising. Figure 4 shows a comparison of predicted and measured room temperature and heat extraction rate for a simple one room test building studied by Kimura and Ishino.

Calculated room temperature in Figure 4 is obtained by the transfer functions derived from the measured data of August 19, while the heat extraction was calculated by the transfer functions derived from the measured values of August 13. The good agreement indicated in Figure 4 implies that the detailed calculation is needed only for a limited number of days to derive accurate transfer functions based upon the equivalent thermal mass of the particular building under consideration.

* Private communication with Professor C. F. Sepsey and J. Jones of the Ohio State University.

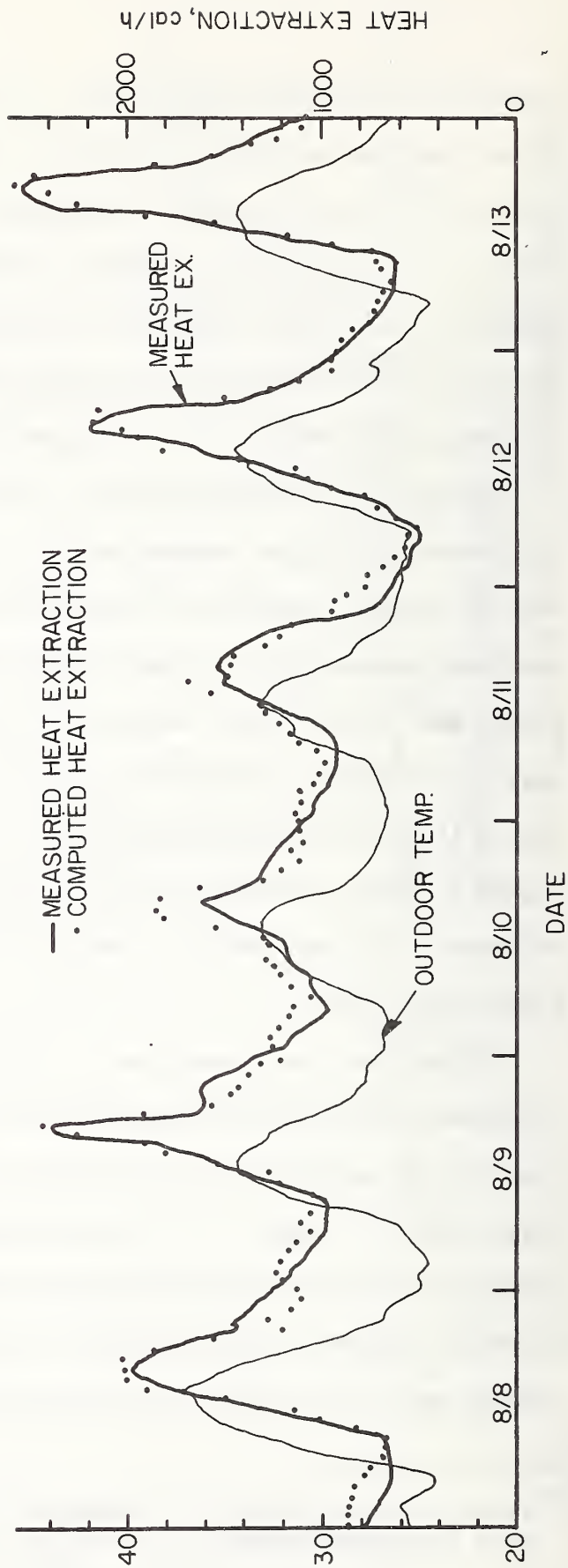
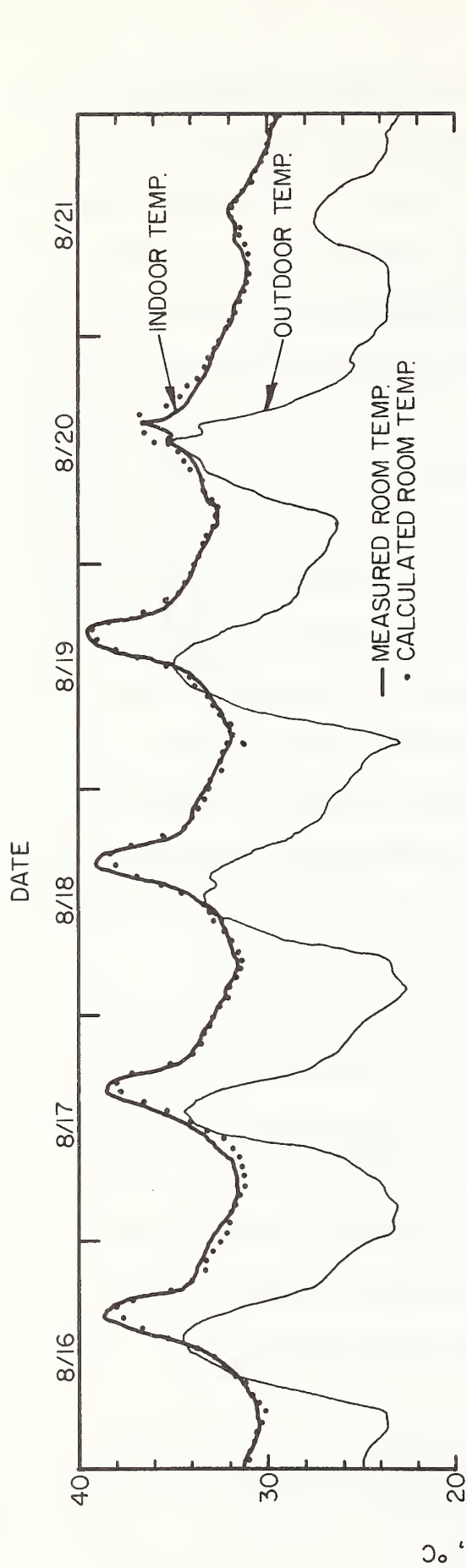

Figure 4 A Comparison of Measured and Calculated Thermal Performance of an Experimental Building (Courtesy of Professor K. Kimura)

3. Unique Features of NBS Load Calculation Computer Program

A comprehensive yet easy-to-use computer program for determining heating and cooling loads has been developed in the Thermal Engineering Systems Section of the Center for Building Technology at the National Bureau of Standards. This computer program is based upon extensive information accumulated over the past decades in various phases of building heat transfer problems, and is intended to be used for the design of equipment and air conditioning systems as well as for estimates of building energy requirements.

The major reason why NBS developed this comprehensive program is that despite the existence of numerous load calculation programs currently available, most of them are not suitable for the analysis of building designs where non-conventional or innovative ideas on structures, heating and cooling systems and controls are employed. Some of the unique aspects of building and system design and operation that can be handled by or studied by using NBSLD are:

1. Inside-out construction of exterior walls where the thermal insulation is placed on the outside of the building shell as opposed to conventional walls having insulation on the inside. (These two walls could have the same U-value and yet their thermal response would be quite different.)
2. Effect of interior partition walls or floor-ceiling sandwich structures on the heat storage characteristics of the room,

3. Off-peak heating or cooling of buildings to shave the peak heating or cooling demand,
4. Evaluation of intentionally undersized heating and cooling equipment by calculating the room temperature and humidity deviations from a design setpoint. (The results would indicate whether or not the indoor conditions would remain within acceptable limits.)
5. Evaluation of indoor thermal environment of various zones during the intermediate season, such as spring and autumn, when the heating or cooling requirements for these zones may not be in phase with that of the building as a whole. (This would apply to a case where a two-pipe system would be installed for example. The central system for the entire building might be switched to heating in late autumn and yet some zones, particularly those facing south may still require cooling. NBSLD can be used to determine the indoor thermal conditions of unheated or uncooled rooms.)
6. Use of solar energy for heating and cooling buildings as it relates to the thermal storage characteristics of the building,
7. Use of attic ventilation to reduce the cooling load since NBSLD can accurately predict attic temperatures,
8. Accurate determination of the need for heating and air conditioning in basement rooms,

9. Design of heating and cooling systems and equipment on the basis of intermittent operation, such as the shutdown of air conditioning facilities during the nighttime or week-ends,
10. Effective use of natural air conditioning such as ventilation, shading, increased ceiling insulation and the subsequent determination of the requirements for mechanical cooling,
11. Effective use of planned ventilation to minimize a building heating load during the winter season,
12. Accurate evaluation of indoor comfort conditions based upon air temperature, humidity and mean-radiant temperature,
13. Determination of the condition whereby moisture condensation takes place along interior surfaces of a building, and
14. The effect of interior furnishings of various simple shapes upon the heating and cooling loads.

Figure 5 depicts an overall calculation sequence to attain the hour by hour heating and cooling load of buildings. Shown in the double lined boxes are input data to be supplied whereas those in single lined boxes indicate calculations to be performed. The cycle indicators show the iteration cycles for the number of buildings, the number of rooms in a given building and the number of days for which the calculations are performed. More specific identification of the types of input data needed

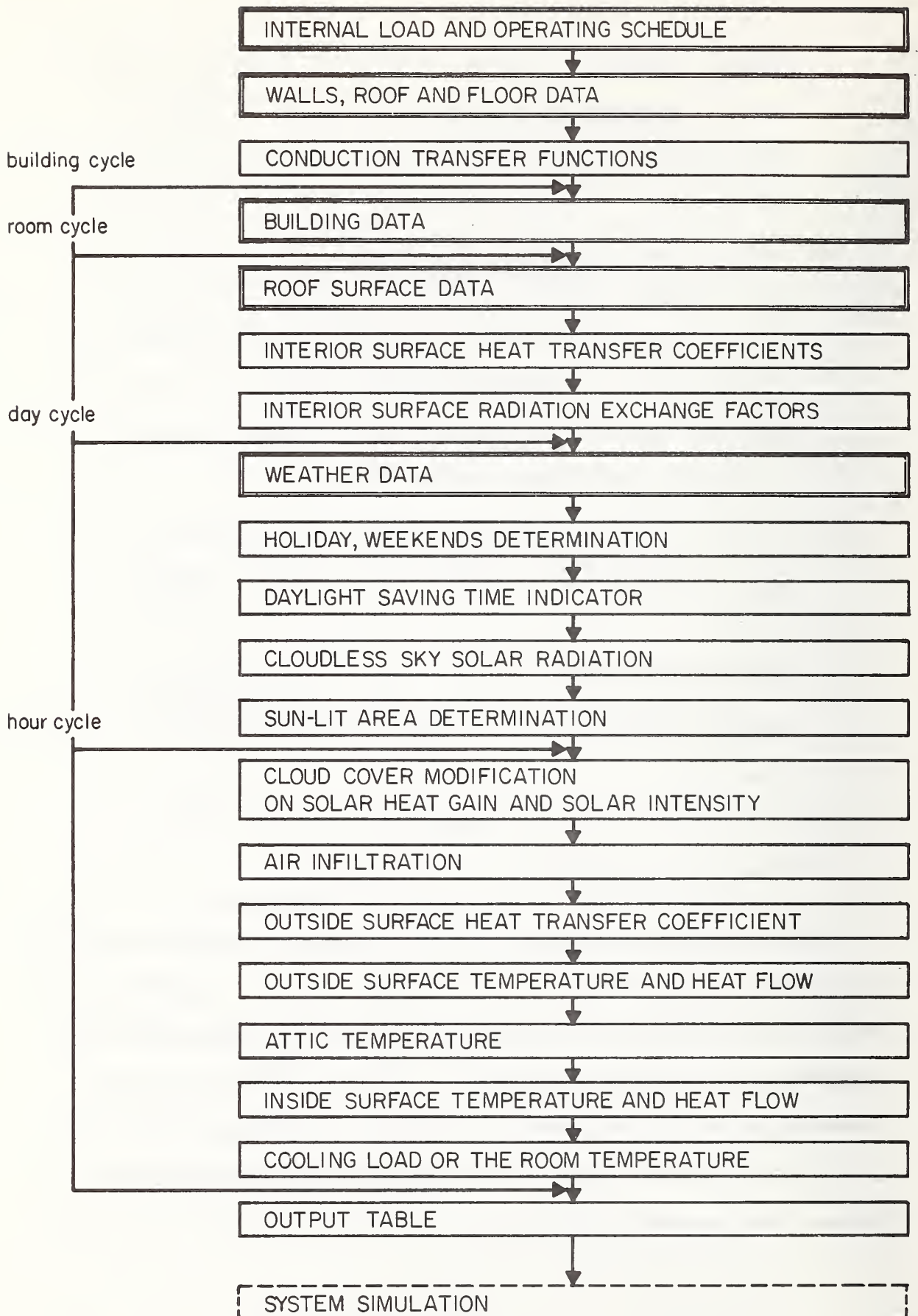

Figure 5 Calculation Sequence of NBSLD

INPUT - OPERATING DATA

- ELECTRIC POWER TO LIGHTS, WATTS PER SQUARE FOOT OF FLOOR (QLITY)
- HOUR BY HOUR LIGHTING SCHEDULE (QLITX)
- ELECTRIC POWER TO EQUIPMENT, WATTS PER SQUARE FOOT OF FLOOR (QEQPX)
- HOUR BY HOUR EQUIPMENT SCHEDULE (QEQUX)
- SUPPLY AIR RATE (CFMS)
- AIR LEAKAGE RATE (CFML)
- SUPPLY AIR TEMPERATURE (TS)

Figure 6

INPUT - BUILDING DATA

- ROOM NUMBER (ROOMNO)
- CEILING HEIGHT (H)
- ROOM LENGTH (L)
- ROOM WIDTH (W)
- NUMBER OF OCCUPANTS (QCU)
- OCCUPANT SCHEDULE (QOCUP)
- WINTER WINDOW OVERALL HEAT TRANSFER COEFFICIENT (UGLAS)
- GROUND FLOOR HEAT TRANSFER COEFFICIENT (UG)
- SUMMER INFILTRATION, AIR CHANGES PER HOUR (ARCHGS)
- WINTER INFILTRATION, AIR CHANGES PER HOUR (ARCHGW)
- TYPE OF HEAT TRANSFER EXPOSURES (ITYPE)
-ROOFS-WALLS-WINDOWS-DOORS-FLOORS
- TYPE OF RESPONSE FACTORS TO BE USED (IRF)
-HEAVY/LIGHT: ROOF, EXTERIOR WALLS, CEILING/FLOOR
PARTITION
- U VALUE OF THE EXPOSURE (U) (ONLY WHEN RESPONSE FACTOR
IS NOT CALCULATED)
- AREA OF THE EXPOSURE (A)
- ORIENTATION OF THE EXPOSURE (AZW) -N,E,S,W (ONLY FOR
EXTERNALLY EXPOSED SURFACES)
- WINDOW SHADING COEFFICIENT (SHADE)
- SOLAR HEAT ABSORPTION COEFFICIENT FOR THE EXTERIOR SURFACE
(ABSP)
- TIME INCREMENT OF TEMPERATURE DATA USED
- PROPERTIES OF BUILDING MATERIALS - THICKNESS - THERMAL
CONDUCTIVITY - DENSITY - SPECIFIC HEAT
- NUMBER OF SURFACES IN EACH WALL (NS,NW,NN,NE)

Figure 7

INPUT - WEATHER DATA

- LATITUDE (LAT)
 - LONGITUDE (LONG)
 - TIME ZONE NUMBER (TZN)
 - MONTH (MONTH)
 - DAY (DAY)
 - ELAPSED DAYS SINCE JANUARY 1 (ELAPS)
-
- MAXIMUM TEMPERATURE OF THE DESIGN DAY (DBMAX)
 - DAILY TEMPERATURE RANGE OF THE DESIGN DAY (RANGE)
 - DESIGN INDOOR TEMPERATURE CONDITION (DBIN)
 - DESIGN OUTDOOR WET-BULB TEMPERATURE (WBMAX)
 - DESIGN INDOOR WET-BULB TEMPERATURE (WBID)
 - DESIGN WINTER OUTDOOR TEMPERATURE (DBMWT)
 - DESIGN SUMMER GROUND TEMPERATURE (TG)
 - DESIGN WINTER GROUND TEMPERATURE (TGW)

Figure 8

are listed in Figures 6, 7 and 8. The exact way the input data is put into the program is specified in Appendix C.

4. General Description of NBSLD Subroutines

In order to perform the chain of calculations depicted in Figure 5, a number of subroutines were developed at the National Bureau of Standards, the algorithms of which have already been published through the ASHRAE Task Group booklet entitled "Procedure for Determining Heating and Cooling Loads for the Computerized Energy Calculations". This booklet, however, contained several errors which have been corrected and is attached to this report as Appendix A. NBSLD incorporates most of the revised ASHRAE algorithms as they are written; however, some of them have been combined or split to fit the overall computational scheme in NBSLD. Listed below is a brief description of the NBSLD subroutines with their specific reference to the ASHRAE algorithms in parentheses.

1. ABCD, ABCDP, ABCD2, ABCDP2, DERVT, GPF, MULT, RESF, RESFX, RESPTK: These routines are parts of the conduction transfer functions calculation package and are needed for the accurate evaluation of thermal time lag, damping, heat storage in exterior facing surfaces as well as the internal furnishings. (XYZ)
2. AIRCON: This routine is used to determine instantaneous values of the physiological indices for the space being studied such as ASHRAE's New Effective Temperature, Predicted Mean Vote (Fanger), Heat Stress Index, KSU Index, Resultant Temperature, Operative Tempera-

ture, and Index of Thermal Stress (Givoni). - not included in the text

3. ATTIC: Attic space temperature and heat conduction through the ceiling into the room below are calculated by this routine for the vented or non-vented attics. (ATTIC)
4. CCM: This routine modifies the solar radiation computed for a cloudless sky by instantaneous cloud cover data. (CCF)
5. DPF: This routine calculates dew point temperature of atmospheric air when the partial vapor pressure is known. (PSY)
6. DST: This routine determines whether a given data is in a daylight saving time zone. The information is needed for the proper assignment of the energy usage schedule. (DST)
7. FCTR: This routine determines radiation exchange factors between any two surfaces which are part of a given room. For the room of six interior surfaces, for example, thirty radiation exchange factors are calculated. These factors are used in turn to determine the rate of heat exchange by radiation between all the interior surfaces. (FIJ)
8. F: This routine calculates radiation heat exchange factors (form factors) between two adjacent rectangular surfaces which are normal to each other, such as that between the floor and wall. (FIJ)

9. FO: This routine calculates the surface heat transfer coefficients for externally exposed surfaces from weather data. (FO)
10. GLASS: This routine calculates solar heat gain through glass when the shading coefficient, orientation, and type of glass are given. (SHG)
11. HOLIDAY: This routine identifies the national holidays in the United States so that the proper holiday schedule can be used for the energy calculation. (HOLIDAY)
12. OUTSID: This routine calculates the outside surface temperature and heat gain into the wall or roof by taking into account solar heating, back radiation to the sky, convective heat loss to the ambient air and transient heat conduction within the wall or roof. (HEATW)
13. PSY1: This is a psychrometric routine that determines the thermodynamic properties of moist air when the dry-bulb temperature, wet-bulb temperature and barometric pressures are given. (PSY)
14. PSY2: This routine is similar to PSY1 except that the dew point temperature is required instead of the wet-bulb temperature. (PSY)
15. PVSF: This routine determines the saturated vapor pressure of atmospheric air as a function of temperature. (PSY)

16. RMTMP: This is the single most important subroutine of NBSLD since it determines the room temperature by solving matrix equations expressing a balance of heat gains, heat storage at the room surfaces, and cooling capacity of an air conditioning unit. However, the room temperature can be prescribed, in which case the routine will calculate the heating/cooling requirements to satisfy that prescribed temperature. (RMTMP)
17. ROOM: This routine reads in all the data required for the room heat transfer calculation such as dimensions, surface area, surface orientations, shading coefficients, surface solar absorptivity, etc.
18. SHG: This is the routine that calculates solar heat gain through glass. (SHG)
19. SOLVP: This routine solves the simultaneous linear algebraic equations that appear in RMTMP. (RMTMP)
20. SUN: Basic sun data such as solar angles, cloud cover, direct and diffuse radiation needed for solar heat gain and solar heating of the building exterior surfaces are calculated in this routine. (SUN, SOLAD)
21. TAR: This routine calculates transmission and absorption characteristics of glass. (TAR)
22. WBF: This is another psychrometric routine that calculates the wet-bulb temperature when the enthalpy of moist air and the barometric pressure are specified. (PSY)

23. WKDAY: This subroutine determines the day of week when the date and year are given. The information is needed for the proper selection of energy usage schedules which are dependent upon whether the day is a weekday or not.
(WKDAY)
24. WD, WDX, DECODE, ERROR, WEATHE: The weather data tape 1440 supplied by the National Climatic Center, Asheville, N. C. is prepared in a format which cannot be readily applicable in most of the Fortran programs. These routines are therefore necessary to read the 1440 tapes and decode them into meaningful weather parameters, which in turn can be used by UNIVAC 1108 Fortran of the National Bureau of Standards. If there are some data which are unreasonable, the data will be replaced by the arithmetic average of two adjacent data by the ERROR routine. (CLIMAT)

All the subroutines in the program may be used to form a separate main program for a specific job. Following are sample usages of some of the subroutines.

1. Psychrometric Calculation

CALL PSY1 (DB, WB, PB, DP, PV, W, H, V, RH)

where inputs are DB = dry-bulb temperature

WB = wet-bulb temperature

PB = barometric pressure

outputs are DP = dew point temperature

PV = vapor pressure

W = humidity ratio

H = enthalpy

V = volume

RH = relative humidity

There is also a routine called PSY2 (DB, DP, PB, WB, PV, W, H, V, RH) in which the inputs are DB, DP and PB instead of DB, WB and PB. In many cases DB and RH are the inputs and the vapor pressure and dew point temperature or the wet-bulb temperature at standard barometric pressure are the outputs. A possible algorithm that could be desired, for example, might be:

PVS = PVSF (DB)

PV = PVS*RH/100

DP = DPF (PV)

Call PSY2 (DB, DP, PB, WB, PV, W, H, V, RH)

2. Solar radiation

Recently there has been increased interest in the application of solar energy for heating of hot water. SUN and GLASS routines should be valuable for evaluating various solar collectors at different locations in the United States at different times of the year. A sample use of these routines may be shown for a solar collector having the following characteristics (Figure 9)

location: latitude = 45° , longitude = 73°

azimuth angle = 0° south

tilt angle = 30° from horizontal surface

area = 500 ft^2

date = July 21

time = 4:00 p.m.

glass cover = double sheet - clear glass

U_R = overall heat transfer coefficient between the collector surface and the ambient, $\text{Btu/hr ft}^2 \text{ }^\circ\text{F}^*$

U_W = overall heat transfer coefficient between the collector surface and water, which is being circulated under the collector plate, $\text{Btu/hr ft}^2 \text{ }^\circ\text{F}$

TWI = water temperature entering the collector, $^\circ\text{F}$.

TWL = water temperature leaving the collector, $^\circ\text{F}$

GPM = water circulation rate in gallons per minute

* When the collector temperature is less than $150 \text{ }^\circ\text{F}$, the typical value of U_R for a flat black collector with double glass cover may be 0.75. The value increases to as much as 1.5 when the collector temperature is in the neighborhood of $300 \text{ }^\circ\text{F}$. A special computer program is available for estimating the value of U_R for various types of collectors.

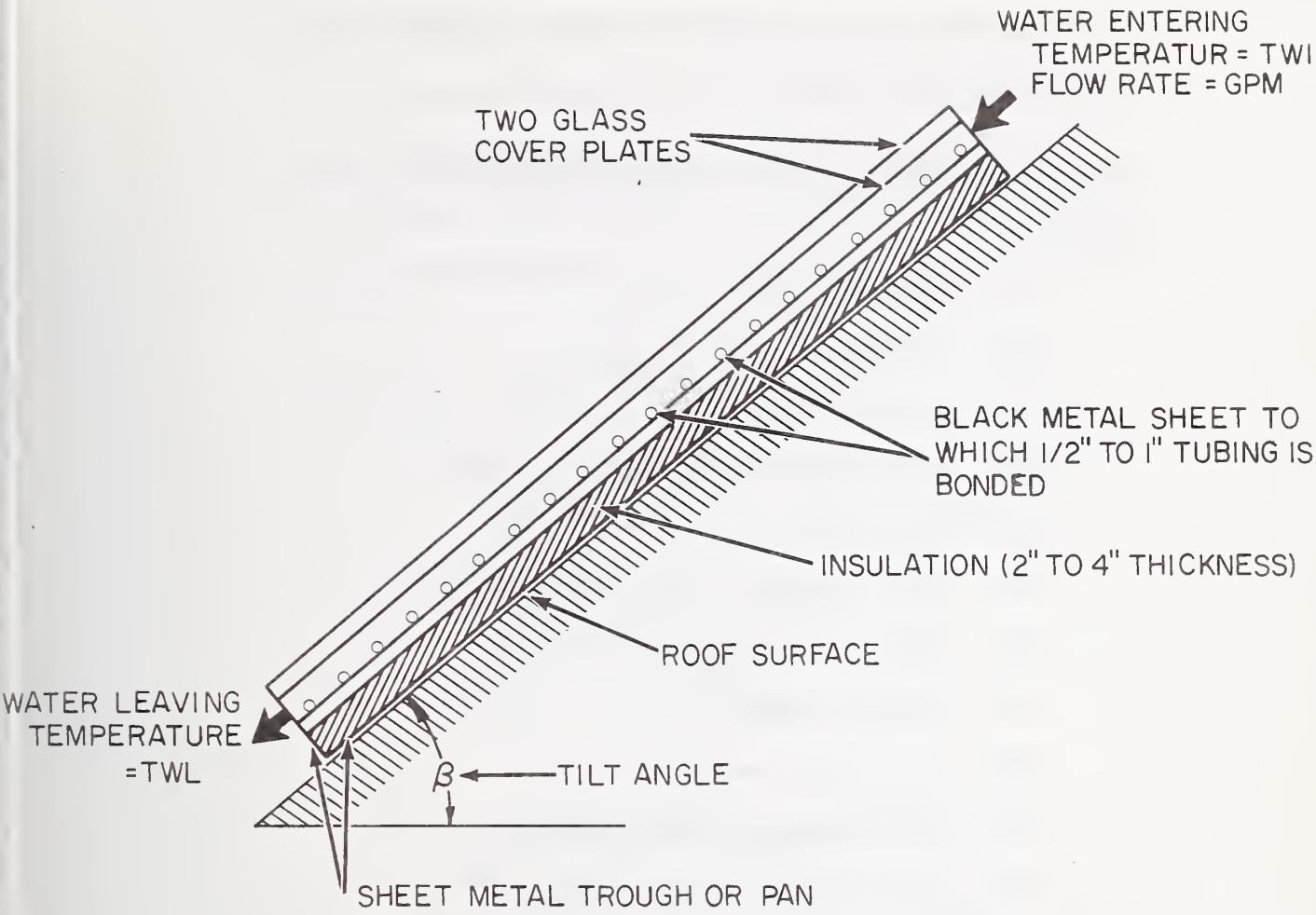

Figure 9 A Typical Flat Plate Solar Collector

It is assumed that the collector is well insulated around the edges and its bottom.

The algorithm for the use of SUN and GLASS routines would then be:

S(1) = LATITUDE = 30

S(2) = LONGITUDE = 73

S(3) = Time zone number = 5

S(4) = Elapsed days since January 1 = 202

S(5) = Time = 16

S(6) = IDST = daylight saving time index = 1

S(7) = Ground reflectivity = 0.2

S(8) = Clearness number = 1.0

S(33) = Cloud cover modifier = 1

S(9) = Azimuth angle of the collector = 0°

S(10) = Tilt angle of the collector = 30°

Call SUN

Call GLASS (SHDW, SHADE, GLASTP, GLAZE, SHG)

note: SHDW = sunlit area factor = 1

SHADE = shading coefficient = not applicable

GLASTP = 1/8" double strength glass (1)

GLAZE = double glazing (2)

SHG = solar heat gain - output

note: SUN and GLASS have S in common using the solar heat gain through the glass plate; the following calculation would be needed to estimate TS, collector surface temperature and TWL, leaving water temperature from the collector:

$$TS = \frac{U_R * DB + U_W * T_W + SHG}{U_R + U_W}$$

$$TWL = TWI + (TS - TWI) (1 - e^{-X})$$

$$\text{where } X = \frac{U_W * A}{500 * GPM}$$

5. NBSLD Logic Diagram

Figure 10 shows the way in which the various subroutines of NBSLD fit together in the usage of the program.

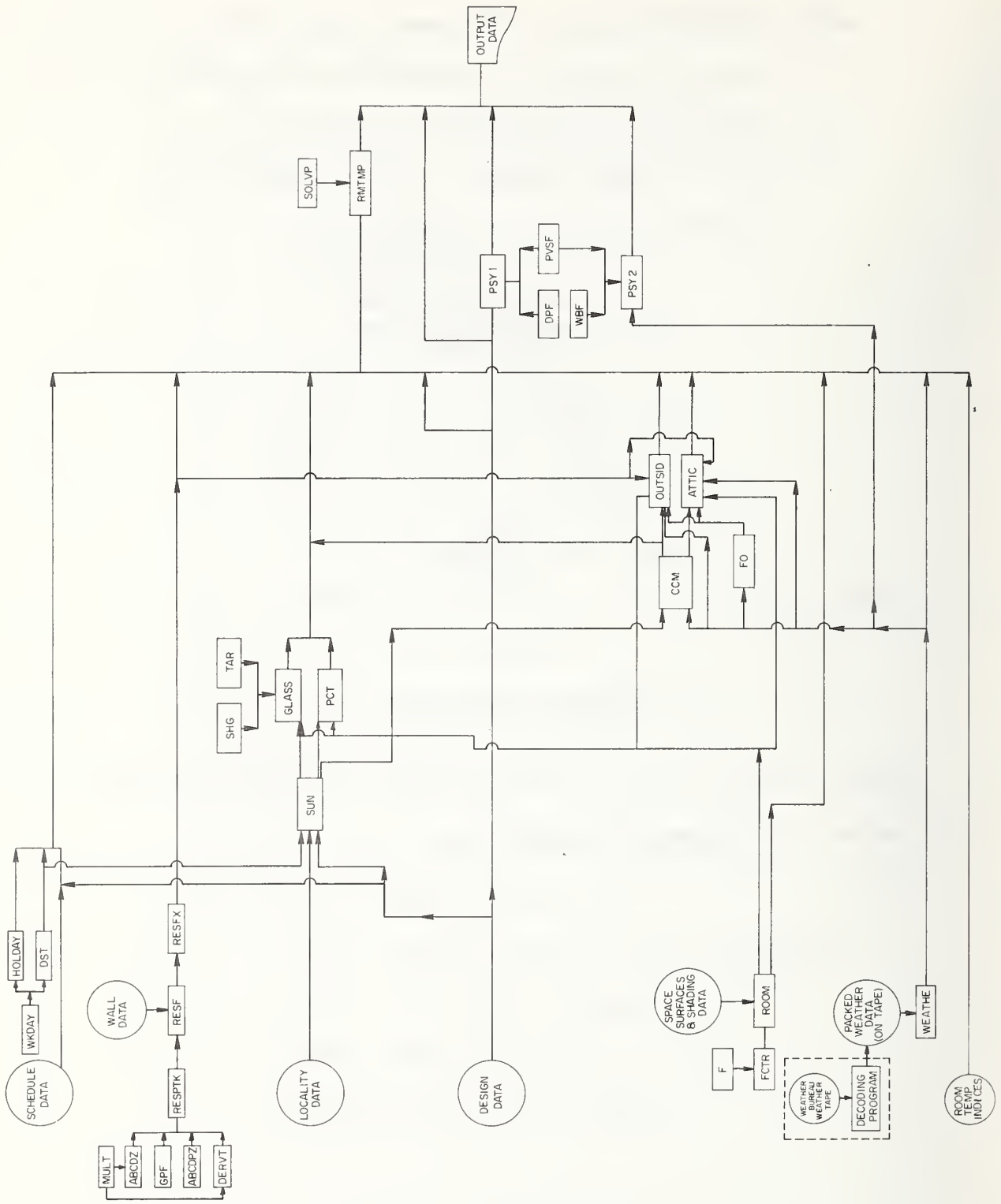

Figure 10 Interrelationship of Various Subroutines for NBSLD

6. References

1. "Pattern of Energy Consumption in the United States", Stanford Research Institute Report, pp. 6-7, January 1972.
2. "Heating Load" and "Air-Conditioning Cooling Load", ASHRAE Handbook of Fundamentals, Chapters 21 and 22, pp. 375-445, 1972.
3. Mitalas, G. P. and Stephenson, D. G., "Room Thermal Response Factors", ASHRAE Transactions, 1967, Vol. II, pp. III 2.1-2.10.
4. Buchberg, H., "Sensitivity of the Thermal Response of Buildings to Perturbations in the Climate", Building Science, Vol. 4, pp. 43-61, Pergamon Press, 1969.
5. Mitalas, G. P., "An Experimental Check on the Weighting Factor Method of Calculating Room Cooling Load", ASHRAE Transactions, 1969, pp. 222-232.
6. Kusuda, T., Tsuchiya, T. and Powell, F. J., "Prediction of Temperature by Using Equivalent Thermal Mass Response Factors", Proceedings of the 5th Symposium on Temperature, National Bureau of Standards, 1971.
7. Kimura, K. and Ishino, H., "Air Conditioning Load Calculation by the Equivalent Mass Weighting Factor Method for the Computerized Control", Proceedings of the Japanese Architectural Society, pp. 249-250, Kyushu meeting, October 1972 and Proceedings for the Second Symposium on the Use of Computers for Thermal Engineering Related to Buildings, COSTIC, 1974.

7. Appendix A

Subroutine Algorithms Prepared for the
ASHRAE Task Group on Energy Requirements

CLIMAT

A Procedure for Obtaining Climatic Weather Data

Climatic parameters needed for the hourly load calculations are:

- DB: Dry-bulb temperature, F
- DP or WB: Dew point or wet-bulb temperature, F
- CT: Cloud type
- TC: Total cloud amount
- V: Wind speed, knots
- DIR: Wind direction (clockwise from North), degrees
- PB: Barometric Pressure, in. Hg
- ID: Direct Solar Radiation, Btu per (hr) (sq ft)
- $I_{d,sky}$: Sky diffuse radiation, Btu per (hr) (sq ft)
- $I_{d,ground}$: Ground diffuse radiation, Btu per (hr) (sq ft)
- Rain, Snowfall: Precipitation data (Optional)

Hourly observations of these weather parameters for past years are available from the National Climatic Center either on magnetic tape or in card deck form. The hourly solar radiation data has been recorded for only approximately fifty stations throughout the United States (Table A-1). These data are, moreover, limited in their durations and completeness, and scarcely useful for the comprehensive energy analysis. On the other hand, the data series 144 includes the hourly observations of all of the parameters listed above except the solar radiation for more than 300 weather stations (Table A-2) covering a period of from ten to thirty years. Since the 144 series data are very much complete, it is

recommended that hour by hour energy calculations be made with this series of data supplemented by simulated solar radiation data. A method for simulating solar radiation will be described later in this booklet.

Because of the specific coding scheme employed by the National Climatic Center for storing the hourly weather data onto the magnetic tapes, the 144 series is not directly usable by the standard Fortran programs. Different computing systems such as IBM 370, CDC 6600 and UNIVAC 1108 have their own decoding routines to read these tapes. Included in this section is a listing of a Fortran program which illustrates a decoding scheme required to make use of the weather tapes. This listing was prepared by Mr. McKay, Data Reduction Section, of the National Climatic Center, Asheville, North Carolina.

For further information on the procurement of weather tapes and possible assistance in decoding, the following office may be contacted:

Mr. G. McKay or D. Calloway
National Climatic Center
Applied Climatology Division
Federal Building
Asheville, North Carolina 28801
Tel. (704) 254-0961 x203

Table A-1 Solar Radiation Data

| | |
|---------------------------------|-------------------------------|
| Albuquerque, New Mexico | Lake Charles, Louisiana |
| Apalachicola, Florida | Lake Charles, Louisiana |
| Barrow, Alaska | Lincoln, Nebraska |
| Bethel, Alaska | Lincoln, Nebraska |
| Bismark, North Dakota | Los Angeles, California |
| Blue Hill/Milton, Massachusetts | Madison, Wisconsin |
| Boston, Massachusetts | Matanuska, Alaska |
| Brownsville, Texas | Medford, Oregon |
| Canton Island | Miami, Florida |
| Cape Hatteras, North Carolina | Nashville, Tennessee |
| Caribou, Maine | New York, New York |
| Charleston, South Carolina | Oak Ridge, Tennessee |
| Cleveland, Ohio | Omaha, Nebraska (North Omaha) |
| Columbia, Missouri | Phoenix, Arizona |
| Dodge City, Kansas | Riverside, California |
| El Paso, Texas | Santa Maria, California |
| Ely, Nevada | Santa Maria, California |
| Fairbanks, Alaska | Sault Ste. Marie, Michigan |
| Fort Worth, Texas | Seattle, Washington |
| Fort Worth, Texas | Sterling, Virginia |
| Fresno, California | Tucson, Arizona |
| Grand Lake/Granby, Colorado | Upton, New York |
| Great Falls, Montana | Wake Island |
| Hatteras, North Carolina | Washington, D. C. |
| Inyokern, California | |

Table A-2

U.S. DEPARTMENT OF COMMERCE
NATIONAL OCEANIC AND ATMOSPHERIC ADMINISTRATION
ENVIRONMENTAL DATA SERVICE

Stations for which Local Climatological Data are issued, as of January 1, 1972

| | | | | | | | | | |
|-----|----------------------------|-----|-----------------|-----|----------------------|-----|-----------------------|-----|--------------------|
| abc | ALABAMA | | FLORIDA | | MASSACHUSETTS | | NEW YORK (Contd.) | | SOUTH DAKOTA |
| abc | Birmingham | ac | Apalachicola | abc | Boston | abc | Buffalo | abc | Aberdeen |
| abc | Huntsville | abc | Daytona Beach | ac | Blue Hill Obs. | abc | New York | abc | Huron |
| abc | Mobile | abc | Fort Myers | abc | Worcester | abc | Central Park | abc | Rapid City |
| abc | Montgomery | abc | Jacksonville | abc | | abc | J.F. Kennedy Int'l AP | abc | Sioux Falls |
| | | abc | Key West | | MICHIGAN | | LaGuardia Field | | |
| | ALASKA | ac | Lake land | abc | Alpena | abc | Rochester | | TENNESSEE |
| abc | Anchorage | abc | Miami | abc | Detroit | abc | Syracuse | abc | Bristol |
| abc | Annette | abc | Orlando | abc | City Airport | | | abc | Chattanooga |
| abc | Barrow | abc | Pensacola | abc | Detroit Metro AP | | | abc | Knoxville |
| abc | Bartel Island | abc | Tallahassee | abc | Flint | abc | NORTH CAROLINA | abc | Memphis |
| abc | Bethel | abc | Tampa | abc | Grand Rapids | abc | Asheville | abc | Nashville |
| abc | Bettles | abc | West Palm Beach | abc | Houghton Lake | abc | Cape Hatteras | abc | Oak Ridge |
| abc | Big Delta | | | abc | Lansing | abc | Charlotte | a | Area Stations |
| abc | Cold Bay | | | abc | Marquette | abc | Greensboro | ac | City |
| abc | Fairbanks | abc | GEORGIA | ac | Muskegon | abc | Raleigh | | |
| abc | Gulkana | abc | Athens | abc | Sault Ste. Marie | abc | Wilmington | | TEXAS |
| abc | Homer | abc | Atlanta | abc | | | | | Abilene |
| abc | Juneau | abc | Augusta | | MINNESOTA | abc | NORTH DAKOTA | abc | Amarillo |
| abc | King Salmon | abc | Columbus | abc | Duluth | abc | Bismarck | abc | Austin |
| abc | Kotzebue | ac | Macon | abc | International Falls | abc | Fargo | abc | Brownsville |
| abc | McCrath | abc | Rome | abc | Minneapolis-St. Paul | abc | Williston | abc | Brownsville |
| abc | Nome | abc | Savannah | abc | Rochester | abc | | abc | Corpus Christi |
| abc | St. Paul Island | | | abc | St. Cloud | abc | OHIO | abc | Dallas |
| abc | Shemya | abc | HAWAII | | | | Akron-Canton | abc | Del Rio |
| abc | Summit | abc | Hilo | | MISSISSIPPI | ac | Cincinnati | abc | El Paso |
| abc | Talkeetna | abc | Honolulu | abc | Jackson | abc | Abbe Obs. | abc | Fort Worth |
| abc | Unalakleet | abc | Kahului | abc | Meridian | abc | Airport | ac | Galveston |
| abc | Yakutat | abc | Lihue | abc | | abc | Cleveland | abc | Houston |
| | | | | | MISSOURI | | Columbus | abc | Lubbock |
| | ARIZONA | abc | IDAHO | abc | Columbia | abc | Dayton | abc | Midland |
| abc | Flagstaff | abc | Boise | abc | Kansas City | abc | Mansfield | abc | Port Arthur |
| abc | Phoenix | abc | Lewiston | abc | St. Joseph | abc | Toledo | abc | San Angelo |
| abc | Tucson | | Pocatello | abc | St. Louis | abc | Youngstown | abc | San Antonio |
| abc | Winslow | | | abc | Springfield | abc | | abc | Victoria |
| abc | Yuma | ac | ILLINOIS | abc | | | OKLAHOMA | abc | Waco |
| | | abc | Cairo | abc | | | Oklahoma City | abc | Wichita Falls |
| | ARKANSAS | abc | Chicago | abc | MONTANA | abc | Tulsa | | UTAH |
| abc | Fort Smith | ab | Midway Airport | abc | Billings | abc | | ac | Milford |
| abc | Little Rock | abc | O'Hare Airport | abc | Glasgow | abc | OREGON | abc | Salt Lake City |
| | | abc | | abc | Great Falls | abc | Astoria | abc | Wendover |
| | CALIFORNIA | abc | | abc | Havre | abc | Burns | | VERMONT |
| abc | Bakersfield | abc | INDIANA | abc | Helena | abc | Eugene | abc | Burlington |
| abc | Bishop | abc | Evansville | abc | Kalispell | abc | Meacham | | |
| ac | Blue Canyon | abc | Fort Wayne | abc | Miles City | abc | Medford | abc | |
| ac | Eureka | abc | Indianapolis | abc | Missoula | abc | Pendleton | | VIRGINIA |
| abc | Fresno | abc | South Bend | abc | | abc | Portland | abc | Lynchburg |
| abc | Long Beach | abc | | abc | NEBRASKA | abc | Salem | abc | Norfolk |
| abc | Los Angeles Airport | abc | IOWA | abc | Grand Island | abc | Sexton Summit | abc | Richmond |
| ac | Los Angeles | abc | Burlington | abc | Lincoln | abc | | abc | Roanoke |
| | Civic Center | abc | Des Moines | abc | Norfolk | abc | PACIFIC ISLANDS | abc | Walllops Island |
| abc | Mt. Shasta | abc | Dubuque | abc | North Platte | abc | Guam | ab | |
| abc | Oakland | abc | Sioux City | abc | Omaha | abc | Johnston | | WASHINGTON |
| abc | Red Bluff | abc | Waterloo | ac | Scottsbluff | abc | Koror | abc | Olympia |
| abc | Sacramento | abc | | abc | Valentine | abc | Kwajalein | abc | Quillayute Airport |
| abc | Sandberg | abc | KANSAS | abc | | abc | Majuro | abc | Seattle-Tacoma AP |
| abc | San Diego | abc | Concordia | abc | NEVADA | abc | Pago Pago | abc | Spokane |
| abc | San Francisco | abc | Dodge City | abc | Elko | abc | Ponape | abc | Stampede Pass |
| abc | Airport | abc | Coodland | abc | Ely | abc | Truk (Moen) | abc | Walla Walla |
| ac | City | abc | Topeka | abc | Las Vegas | abc | Wake | ac | Yakima |
| abc | Santa Maria | abc | Wichita | abc | Reno | abc | Yap | | |
| abc | Stockton | abc | | abc | Winnemucca | abc | | | WEST INDIES |
| | | | KENTUCKY | abc | | | PENNSYLVANIA | abc | San Juan, P. R. |
| | COLORADO | abc | Lexington | ac | NEW HAMPSHIRE | abc | Allentown | | |
| abc | Alamosa | abc | Louisville | abc | Concord | abc | Frie | | WEST VIRGINIA |
| abc | Colorado Springs | abc | | abc | Mt. Washington | abc | Harrisburg | abc | Bekley |
| abc | Denver | | LOUISIANA | abc | | abc | Philadelphia | abc | Charleston |
| abc | Grand Junction | abc | Alexandria | abc | NEW JERSEY | abc | Pittsburgh | abc | Elkins |
| abc | Pueblo | abc | Baton Rouge | a | Atlantic City | abc | Airport | abc | Huntington |
| | | abc | Lake Charles | abc | Airport | ac | City | abc | Parkersburg |
| | CONNECTICUT | abc | New Orleans | ac | State Marina | abc | Scranton | ac | |
| abc | Bridgeport | abc | Shreveport | ac | Newark | abc | Williamsport | | WISCONSIN |
| abc | Hartford | | | | Trenton | | | | Green Bay |
| | DELAWARE | abc | MAINE | abc | NEW MEXICO | ac | RHODE ISLAND | abc | La Crosse |
| abc | Wilmington | abc | Caribou | ac | Albuquerque | abc | Block Island | abc | Madison |
| | | abc | Portland | abc | Clayton | | Providence | abc | Milwaukee |
| | DISTRICT OF COLUMBIA | abc | | | Roswell | | | | WYOMING |
| abc | Washington-National AP | abc | MARYLAND | abc | NEW YORK | abc | SOUTH CAROLINA | abc | Casper |
| abc | Washington-Dulles Int'l AP | abc | Baltimore | abc | Albany | a | Charleston | abc | Cheyenne |
| | | | | abc | Binghamton | abc | Airport | abc | Lander |
| | | | | | | abc | City | abc | Sheridan |
| | | | | | | | Columbia | abc | |
| | | | | | | | Greenville- | abc | |
| | | | | | | | Spartanburg | | |

a. Monthly summary issued. b. Monthly summary includes available 3-hourly observations. c. Annual Summary issued.
Published if 5 or more available per day.

Subscription Price: Monthly Local Climatological Data \$ 2.00 per year including annual Summary if published. Single copy prices: 20 cents for monthly Summary; 15 cents for annual Summary. Back issues sell at single copy rates. Checks and money orders should be made payable to, and remittances and correspondence should be sent to the Superintendent of Documents, Government Printing Office, Washington, D. C., 20402.

SUBROUTINE SIGNCK(IFLD,ISGN)

C THIS SUBROUTINE WILL TEST ANY PSYCHROMETRIC WITH A SIGN
 C OVER UNITS POSITION READ AS A1 AND THE HIGH ORDER POSITION
 C AS AN I SPEC OF PROPER WIDTH.
 C THE SIGN SHOULD ENTER THE PARAMETER LIST AS ISGN,
 C THE REMAINING PORTION AS IFLD.
 C UPON RETURN FROM THIS ROUTINE, THE VALUE OF THE FIELD
 C WILL BE AN INTEGER WITH PROPER SIGN.
 C IT WILL BE THE USER RESPONSIBILITY TO CONVERT THIS TO REAL
 C FORM WITH PROPER DECIMAL ALIGNMENT.
 C INVALID CONDITION CAUSED IFLD TO BE SET TO 9999

DIMENSION IP(10),MIN(10),NUM(10)

DATA IP/'A','B','C','D','E','F','G','H','I','⁺Ø'/
 DATA MIN/'J','K','L','M','N','O','P','Q','R','⁻Ø'/
 DATA NUM/1,2,3,4,5,6,7,8,9, Ø /,IAST/'*'/

IF (ISGN.EQ.IAST) GO TO 16

DO 14 K=1,10

IF (ISGN.EQ. IP(K)) GO TO 20

IF (ISGN.EQ.MIN(K)) GO TO 22

14 CONTINUE

16 IFLD+9999

RETURN

20 IFLD=IFLD*10+NUM(K)

RETURN

22 IFLD= -(IFLD*10+NUM(K))

RETURN

END

SUN

An Algorithm to Find Solar Position, and Intensity of Direct Normal and Diffuse Radiation

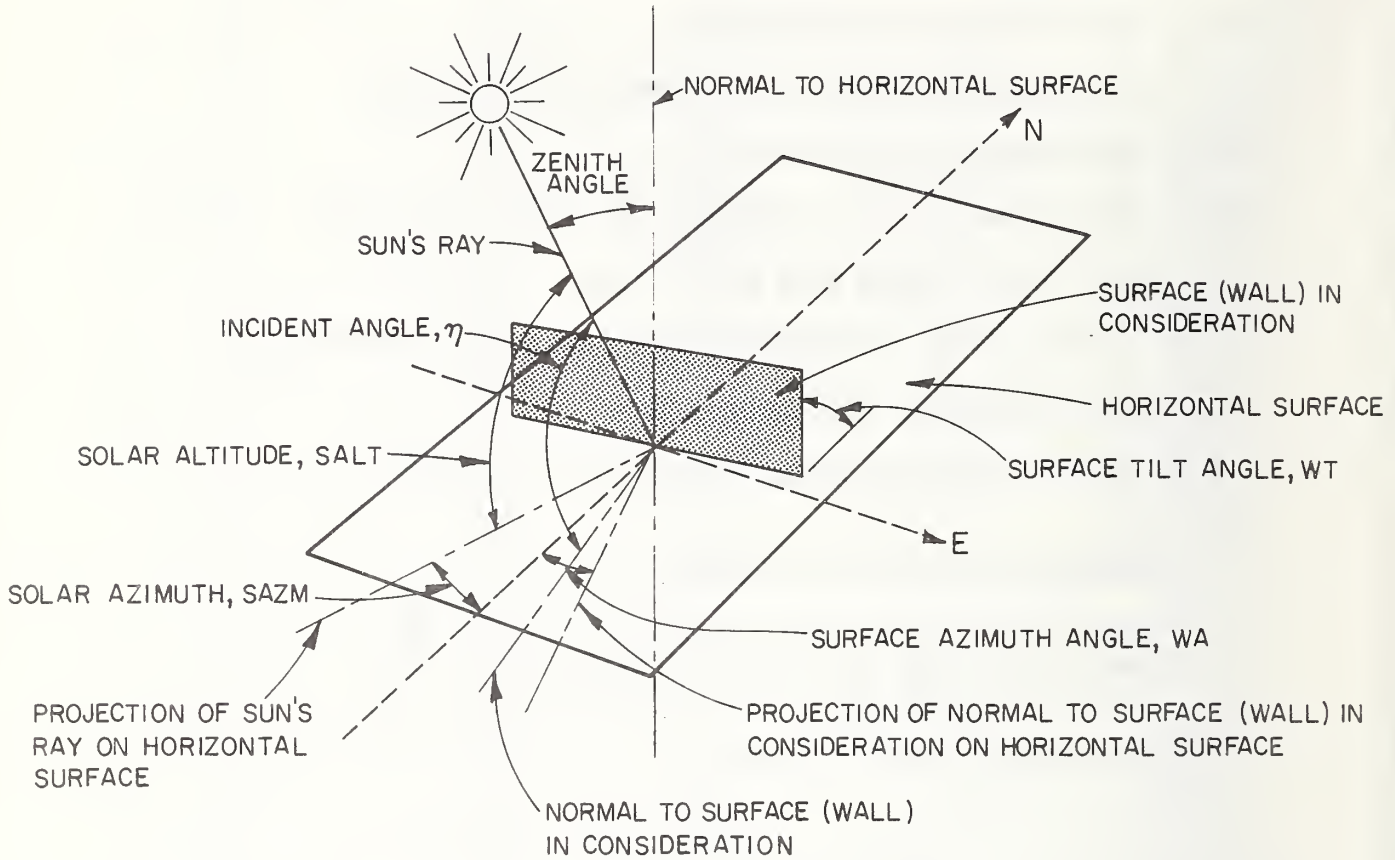

Figure A-1 Solar Angles for Tilted and Horizontal Surfaces

Figure A-1 DEFINITIONS OF SOLAR ANGLE

Data:

L: Latitude, degrees, $\begin{bmatrix} +\text{North} \\ -\text{South} \end{bmatrix}$

ℓ : Longitude, degrees, $\begin{bmatrix} +\text{West} \\ -\text{East} \end{bmatrix}$

TZN: Time zone number (hours behind Greenwich mean time),
(see Figure A-3 and Table A-4)

d: Date, days (from start of year), (1 - 366)

t: Time, hours (after midnight), (0 - 24)

DST: Daylight saving time indicator (Output of DST),
0 for standard time and 1 for daylight saving time

ρ_g : Ground reflectivity

CN: Clearness number (see Figure A-4)

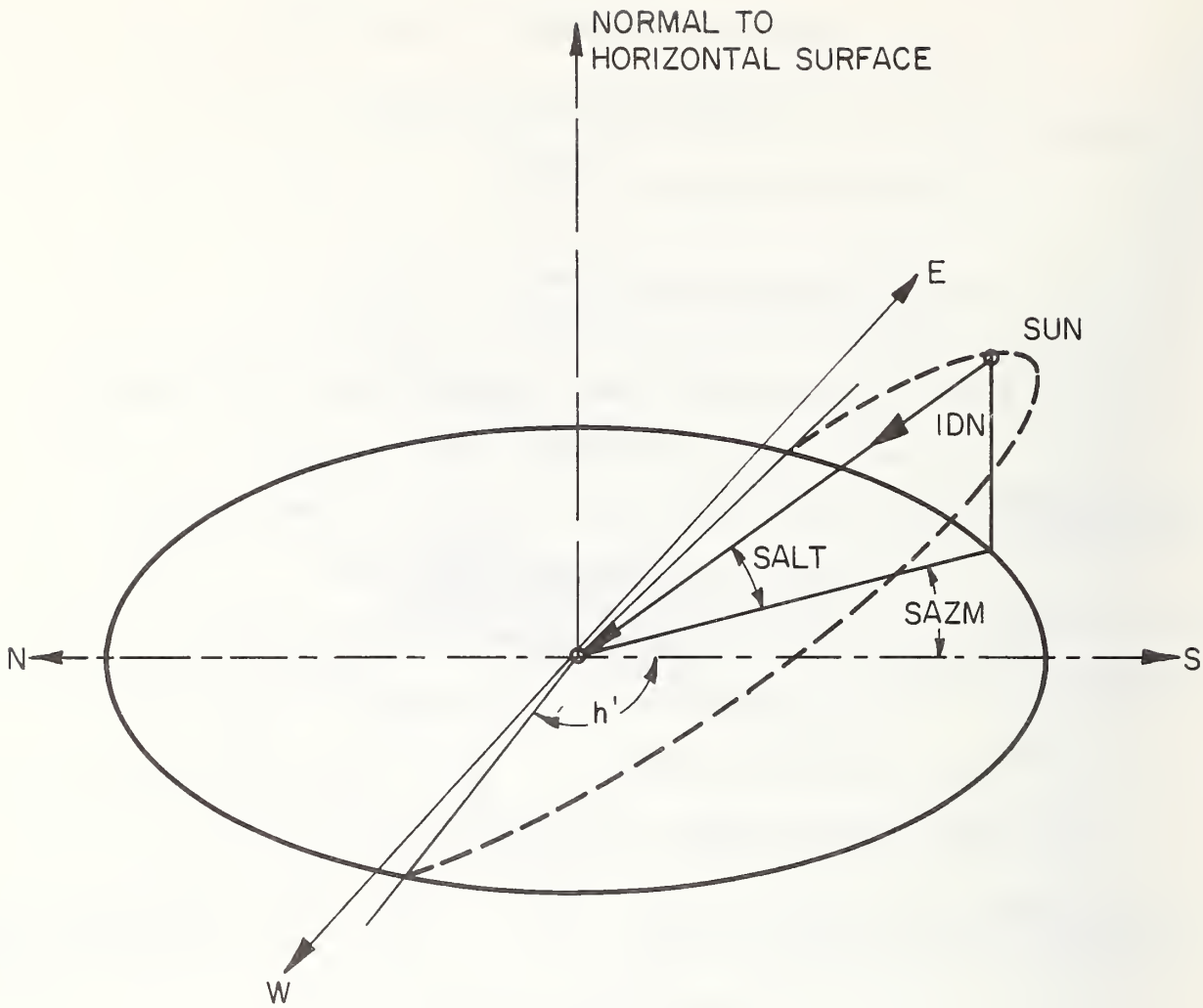

Figure A-2 Schematic Showing Apparent Path of Sun and Hour Angle

Figure A-3 Time Zones in the United States

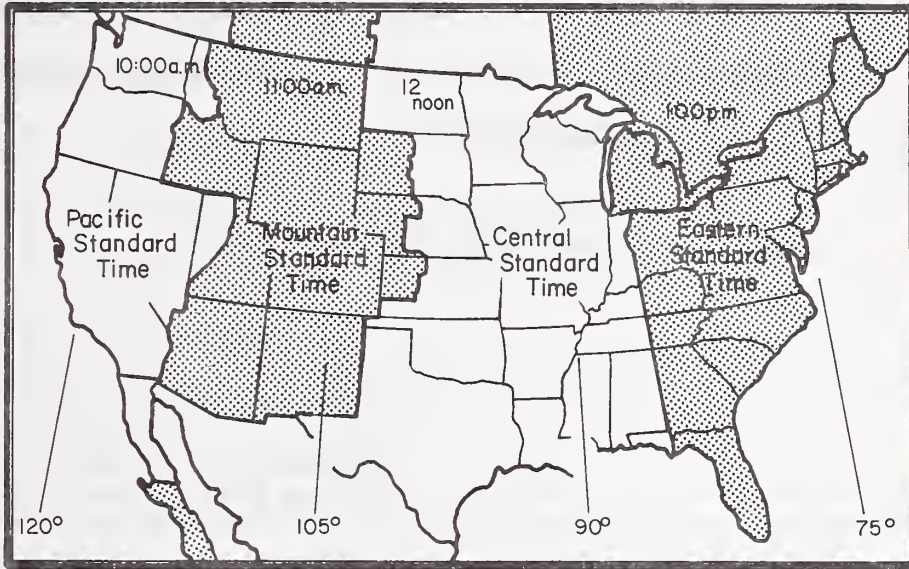

Table A-3 Time Zone Numbers in U. S. for Standard Time

| TIME ZONE | TZN |
|-----------|-----|
| Atlantic | 4 |
| Eastern | 5 |
| Central | 6 |
| Mountain | 7 |
| Pacific | 8 |

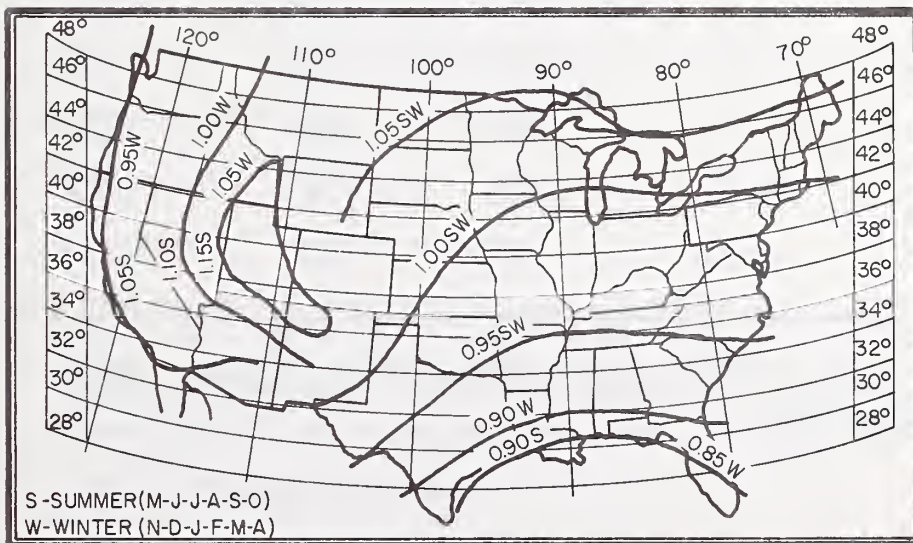

Figure A-4 Clearness Numbers of Non-Industrial Atmosphere in United States

Table A-4 lists, as function of date, five variables related to solar radiation. These variables are declination angle, δ ; the equation of time, ET; the apparent solar constant, A; the atmospheric extinction coefficient, B; the sky diffuse factor, C.

TABLE A-4 VALUES OF δ , ET, A, B AND C*

| Date | δ Degrees | ET Hours | A Btu Per (hr) (sq ft) | B Air Mass ⁻¹ | C |
|----------|---------------------|-------------|------------------------------|--------------------------------|-------|
| Jan. 21 | -20.0 | -.190 | 390 | 0.142 | 0.058 |
| Feb. 21 | -10.8 | -.230 | 385 | 0.144 | 0.060 |
| Mar. 21 | 0.0 | -.123 | 376 | 0.156 | 0.071 |
| Apr. 21 | 11.6 | .020 | 360 | 0.180 | 0.097 |
| May 21 | 20.0 | .060 | 350 | 0.196 | 0.121 |
| June 21 | 23.45 | -.025 | 345 | 0.205 | 0.134 |
| July 21 | 20.6 | -.103 | 344 | 0.207 | 0.136 |
| Aug. 21 | 12.3 | -.051 | 351 | 0.201 | 0.122 |
| Sept. 21 | 0.0 | .113 | 365 | 0.177 | 0.092 |
| Oct. 21 | -10.5 | .255 | 378 | 0.160 | 0.073 |
| Nov. 21 | -19.8 | .235 | 387 | 0.149 | 0.063 |
| Dec. 21 | -23.45 | .033 | 391 | 0.142 | 0.057 |

* Derived from the 1972 ASHRAE Handbook of Fundamentals, Table 1, p. 387, Chapter 22.

Calculation Sequence:

1. Determine δ , ET, A, B, and C from Table A-4

2. $h' = \cos^{-1} (-\tan(L) \cdot \tan(\delta))$ (see Figure A-2)

3. $Y = h' \cdot 12 / \pi$

4. Sunrise time (SRT) and sunset time (SST) in hr

$$SRT = 12 - Y - ET - TZN + \ell / 15$$

$$SST = 24 - SRT$$

5. Hour angle h in degrees

$$h = 15 \cdot (t - 12 + TZN + ET) - \ell$$

If $|h| > |h'|$ skip all the remaining calculations in this sequence and set

$$IDN = 0$$

$$BS = 0$$

$$BG = 0$$

6. Direction cosines of direct solar beam

$$\cos(Z) = \sin(L) \cdot \sin(\delta) + \cos(L) \cdot \cos(\delta) \cdot \cos(h)$$

$$\cos(W) = \cos(\delta) \cdot \sin(h)$$

$$\cos(S) = (1 - (\cos(Z))^2 - (\cos(W))^2)^{0.5}$$

If $\cos(h) > \tan(\delta) / \tan(L)$, $\cos(S)$ is positive

7. Solar altitude angle in radians

$$SALT = \sin^{-1} (\cos(Z))$$

8. Solar azimuth angle in radians

$$SAZM = \sin^{-1} (\cos(W) / \cos(SALT)), \text{ if } \cos(S) > 0$$

$$SAZM = \pi - \sin^{-1} (\cos(W) / \cos(SALT)), \text{ if } \cos(S) < 0$$

9. Intensity of direct solar radiation for a cloudless condition

$$IDN = A \cdot CN \cdot \exp(-B / \cos(Z))$$

10. Diffuse sky radiation (sky brightness) for a cloudless condition

$$BS = C * IDN / (CN) ** 2$$

11. Ground reflected radiation for a cloudless condition (ground brightness)

$$BG = \rho_g * (BS + IDN * \cos(Z))$$

Calculation Modification for Southern Hemisphere:

The preceding algorithm is applicable to the northern hemisphere only. For buildings in the southern hemisphere, the following modifications are required.

1. Shift values of B and C in Table A-4 by six months.

Values of δ , ET, A, B and C for the southern hemisphere are shown in Table A-5.

TABLE A-5 VALUES OF δ , ET, A, B and C FOR SOUTHERN HEMISPHERE

| Date | δ Degrees | ET Hours | A | B | C |
|----------|---------------------|-------------|-------------------------|---------------------------|-------|
| | | | Btu per (hr) (sq ft) | Air ⁻¹ Mass | |
| Jan. 21 | -20.0 | -.190 | 390 | 0.207 | 0.136 |
| Feb. 21 | -10.8 | -.230 | 385 | 0.201 | 0.122 |
| Mar. 21 | 0.0 | -.123 | 376 | 0.177 | 0.092 |
| Apr. 21 | 11.6 | .020 | 360 | 0.160 | 0.073 |
| May 21 | 20.0 | .060 | 350 | 0.149 | 0.063 |
| June 21 | 23.45 | -.025 | 345 | 0.142 | 0.057 |
| July 21 | 20.6 | -.103 | 344 | 0.142 | 0.058 |
| Aug. 21 | 12.3 | -.051 | 351 | 0.144 | 0.060 |
| Sept. 21 | 0.0 | .113 | 365 | 0.156 | 0.071 |
| Oct. 21 | -10.5 | .255 | 378 | 0.180 | 0.097 |
| Nov. 21 | -19.8 | .235 | 387 | 0.196 | 0.121 |
| Dec. 21 | -23.45 | .033 | 391 | 0.205 | 0.134 |

If $L \geq 0$ and if $\text{Cos}(h) > (\text{Tan}(\delta)/\text{Tan}(L))$, $\text{Cos}(s)$ is positive,
and if $\text{Cos}(h) \leq (\text{Tan}(\delta)/\text{Tan}(L))$, $\text{Cos}(s)$ is negative.

If $L < 0$ and if $\text{Cos}(h) \leq (\text{Tan}(\delta)/\text{Tan}(L))$, $\text{Cos}(s)$ is positive,
if $\text{Cos}(h) > (\text{Tan}(\delta)/\text{Tan}(L))$, $\text{Cos}(s)$ is negative.

CCF

An Algorithm for the Calculation of Cloudy Day Solar Radiation

This routine estimates the factor called CCF to modify the total solar radiation on a horizontal surface with the observed cloud cover data for a cloudy sky condition. The cloud cover observations are made every hour at major weather stations by experienced observers who estimate the amount of cloud on a scale of 0 to 10 and indicate the type of cloud in four different layers. Kimura and Stephenson^{1/} analyzed 1967 Canadian data for observed solar radiation with respect to the cloud cover data, type of cloud, and the calculated solar radiation under a cloudless condition at the same solar time. Based upon their analysis, a comprehensive methodology was developed for calculating the cloudy day solar radiation. The value of CCF, Cloud Cover Factor, is first defined as follows:

$$CCF = ITHC/ITH$$

where

ITHC: Total solar radiation on a horizontal surface under a cloudy sky of given cloud amount and types of cloud

ITH: Total solar radiation calculated for a horizontal surface under a cloudless sky at the same solar hour as of ITHC

Data:

IS: Season index

CA_j: Cloud amount at the j-th layer, where j = 1, 2, 3, and 4

TOC_j: Type of cloud at the j-th layer, where j = 1, 2, 3, and 4

TCA: Total cloud amount

Calculation Sequence:

1. $X = (\sum CA_j)_{\text{cirrus}} + (\sum CA_j)_{\text{cirrostratus}} + (\sum CA_j)_{\text{cirrocumulus}}$

2. Cloud cover

$$CC = TCA - 0.5 * X$$

3. Cloud cover factor

$$CCF = P + Q * CC + R * CC * 2$$

where P, Q, and R are found in the following table

Table A-6

| Season | P | Q | R |
|--------|------|-------|---------|
| spring | 1.06 | 0.012 | -0.0084 |
| summer | 0.96 | 0.033 | -0.0106 |
| autumn | 0.95 | 0.030 | -0.0108 |
| winter | 1.14 | 0.003 | -0.0082 |

The value of P, which is essentially the cloudless sky factor, depends upon the proportion of direct to diffuse sky radiation in reference to the standard ASHRAE values published in the 1972 Handbook of Fundamentals. If the value of P is unity, this proportion of direct to diffuse solar radiation is such that the solar radiation evaluated for a hori-

zontal surface under a cloudless sky should be equal to the value obtained by the method described in the 1972 ASHRAE Handbook of Fundamentals. If the value of P is different from unity, the direct to diffuse proportion is different from the standard values.

SOLAD

An Algorithm for Determining Diffuse and Direct Radiation Falling Onto a Surface

This routine determines the total as well as the diffuse and direct components of solar radiation incident on a given surface under either clear or cloudy sky by using the cloudless sky data calculated in the SUN routine and the cloud cover factor CCF calculated as described in the previous section.

Data:

- P: Cloudless sky factor shown in Table (A-6) in the CCF routine
- C: Standard diffuse sky factor shown in Table A-4 in the SUN routine
- CC: Cloud cover calculated in the CCF routine
- CCF: Cloud cover factor determined by the CCF routine
- WA: Azimuth angle of the surface under consideration in radians from south; + if west and - if east of south
- WT: Tilt angle of the surface under consideration in radians from the horizontal surface; zero for the horizontal surface and $\pi/2$ for the vertical walls.

COS(Z), COS(W), AND COS(S):

Direction cosines of direct radiation (Calculated in SUN)

IDN: Intensity of the direct normal solar radiation for a cloudless condition in Btu per (hr) (sq ft) (Calculated in SUN)

BS and BG: Diffuse radiation from the cloudless sky and that from ground in Btu per (hr) (sq ft) (Calculated in SUN)

SALT: Solar altitude angle in radians (Calculated in SUN)

Calculation Sequence:

1. Let $X = \text{SIN}(\text{SALT})$
2. $Y = 0.309 - 0.137 * X + 0.394 * X ** 2$
3. $K = X / (C + X) + (P - 1) / (1 - Y)$
4. Direct radiation on a horizontal surface under a cloudless sky
 $\text{IDH} = \text{IDN} * \text{COS}(Z)$
5. Diffuse radiation on a horizontal surface under a cloudless sky
 $\text{IdH} = \text{BS}$
6. Total radiation on a horizontal surface under a cloudless sky
 $\text{ITH} = \text{IDH} + \text{IdH}$
7. Direct radiation on a horizontal surface under a cloudy sky
 $\text{IDHC} = \text{ITH} * K * (1 - \text{CC} / 10)$

8. Direction cosines of normal to the surface under consideration (the surface has an azimuth angle of WA and a tilt angle of WT)
- $$\alpha = \text{COS}(WT)$$
- $$\beta = \text{SIN}(WA)*\text{SIN}(WT)$$
- $$\gamma = \text{COS}(WA)*\text{SIN}(WT)$$
9. Cosine of the incident radiation on the surface under consideration
- $$\text{COS}(\eta) = \alpha \text{COS}(Z) + \beta \text{COS}(W) + \gamma \text{COS}(S)$$
10. Direct radiation on a surface under consideration under a cloudless sky
- $$\text{ID} = \text{IDN}*\text{COS}(\eta)$$
- $$= 0 \quad \text{if } \text{COS}(\eta) \leq 0$$
11. Direct radiation on a horizontal surface under a cloudy sky
- $$\text{IDC} = \text{ID}*\text{IDHC}/\text{IDH}$$
12. Diffuse radiation for a cloudless sky
- Id = BS for the horizontal surface
- Id = BS*Y + BG/2 for the vertical surfaces*
- where $Y = 0.55 + 0.437*U + 0.313*U**2$
- $$U = \text{COS}(\eta)$$
- $$\text{if } U \leq -0.2, Y = 0.45$$
13. Diffuse radiation upon a horizontal surface under a cloudy sky
- $$\text{IdHC} = \text{ITH}*(\text{CCF}-K*(1 - \text{CC}/10))$$

* Diffuse radiation data for surfaces other than vertical and horizontal ones have not been analyzed sufficiently to date to provide a calculation procedure.

14. Diffuse radiation on a surface under consideration

$$I_{dC} = I_d * I_{dHC} / I_{dH}$$

15. Total radiation upon a surface under a cloudy sky

$$I_{TC} = I_{DC} + I_{dC}$$

When the cloud cover CC is zero,

$$I_{TC} = I_T = I_D + I_d$$

TAR

An Algorithm for Calculating Transmission, Absorption and Reflection Factors for Windows

Data:

$\text{Cos}(\eta)$: Cosine of angle of incidence of direct solar radiation (Calculated in SUN)

$k \cdot \ell$: Extinction coefficient [inches^{-1}] * thickness
[inches]

NOTE: In some cases, glass manufacturers provide the value of transmission at normal incidence. In this case, using the curve given in Figure A-5, it is possible to obtain the value of $k \cdot \ell$. The data for the curve are taken from reference 2.

Calculation Sequence:

A. Single-Pane Glass

1. Cosine of refraction angle

$$\text{COS}(\xi) = \text{SQRT} (1 - (1 - \text{COS}(\eta) ** 2) / n)$$

where $n = 1.520$, which is the index of refraction for ordinary glass.

2. The fraction of radiation that is absorbed in a single pass through a sheet of glass of extinction coefficient $k \cdot \ell$

$$a = 1 - \text{Exp} (-k \cdot \ell / \text{COS}(\xi))$$

3. Single glass air-glass interface reflectivity by the Fresnel's formula

vibration in parallel to the plane of glass

$$r = (\text{TAN } (\eta - \xi)) ** 2 / \text{TAN } (\eta + \xi)$$

vibration in normal to the plane of glass

$$r' = (\text{SIN } (\eta - \xi)) ** 2 / (\text{SIN } (\eta + \xi)) ** 2$$

4. Absorptivity for direct radiation

$$A_{\eta} = 0.5 * (x + x')$$

$$\text{where } x = a * (1 - r) * (1 + r * (1 - a)) / (1 - r * r * (1 - a) * (1 - a))$$

$$x' = a * (1 - r') * (1 + r' * (1 - a)) / (1 - r' * r' * (1 - a) * (1 - a))$$

5. Transmissivity for direct radiation

$$T_{\eta} = 0.5 * (y + y')$$

$$\text{where } y = (1 - r) * (1 - r) * (1 - a) / (1 - r * r * (1 - a) * (1 - a))$$

$$y' = (1 - r') * (1 - r') * (1 - a) / (1 - r' * r' * (1 - a) * (1 - a))$$

6. Absorptivity and transmissivity for diffuse radiation

$$A_d = \int_0^{\pi/2} A_{\eta} \text{SIN } (2\eta) d\eta$$

$$T_d = \int_0^{\pi/2} T_{\eta} \text{SIN } (2\eta) d\eta$$

B. Double-Pane Glass

For the double-pane window, transmissivity and absorptivity for the outer and inner panes can be calculated separately first by using the single-pane procedure described above. Those calculated single glass properties can be designated here as follows:

A_1 : Absorptivity of inner pane for direct radiation

A_2 : Absorptivity of outer pane for direct radiation

T_1 : Transmissivity of inner pane for direct radiation

T_2 : Transmissivity of outer pane for direct radiation

A_{1d} : Absorptivity of inner pane for diffuse radiation

A_{2d} : Absorptivity of outer pane for diffuse radiation

T_{1d} : Transmissivity of inner pane for diffuse radiation

T_{2d} : Transmissivity of outer pane for diffuse radiation

1. Reflectivity of inner and outer panes

$$R_{1\eta} = 1 - A_{1\eta} - T_{1\eta}$$

$$R_{2\eta} = 1 - A_{2\eta} - T_{2\eta}$$

$$R_{1d} = 1 - A_{1d} - T_{1d}$$

$$R_{2d} = 1 - A_{2d} - T_{2d}$$

2. Absorptivity of the double-glazed system

a. Direct radiation

$$A_{\eta, \text{outer}} = A_{2\eta} * (1 + R_{1\eta} * T_{2\eta} / (1 - R_{1\eta} * R_{2\eta}))$$

$$A_{\eta, \text{inner}} = A_{1\eta} * T_{2\eta} / (1 - R_{1\eta} * R_{2\eta})$$

b. Diffuse radiation

$$A_{d,outer} = A_{2d} - (1 + R_{1d} * T_{2d} / (1 - R_{1d} * R_{2d}))$$

$$A_{d,inner} = A_{1d} * T_{2d} / (1 - R_{1d} * R_{2d})$$

3. Transmissivity of the double

a. Direct radiation

$$T_{\eta} = T_{1\eta} * T_{2\eta} / (1 - R_{1\eta} * R_{2\eta})$$

b. Diffuse radiation

$$T_d = T_{1d} * T_{2d} / (1 - R_{1d} * R_{2d})$$

Since the calculation of transmissivity and absorptivity are quite involved, they have been precalculated by Stephenson^{3/} for various values of COS (η) and expressed as polynomial functions of COS (η). The polynomial coefficients are shown in Table A-3 for single and double glazed windows and the equations are as follows:

Single-pane, direct radiation transmission

$$T_{\eta} = \sum_{j=0}^5 t_j * (\text{Cos } (\eta) ** j)$$

Single-pane, diffuse radiation transmission

$$T_d = 2 * \sum_{j=0}^5 t_j / (j + 2)$$

Polynomial representations of absorption factors for direct solar and diffuse radiation.

Double-pane, direct radiation transmission

$$A_{\eta, \text{outer}} = \sum_{j=0}^5 a_{j, \text{outer}} * ((\text{Cos } (\eta) ** j)$$

$$A_{\eta, \text{inner}} = \sum_{j=0}^5 a_{j, \text{inner}} * ((\text{Cos } (\eta) ** j)$$

Double-pane, diffuse radiation transmission

$$A_{d, \text{outer}} = 2 * \sum_{j=0}^5 a_{j, \text{outer}} / (j + 2)$$

$$A_{d, \text{inner}} = 2 * \sum_{j=0}^5 a_{j, \text{inner}} / (j + 2)$$

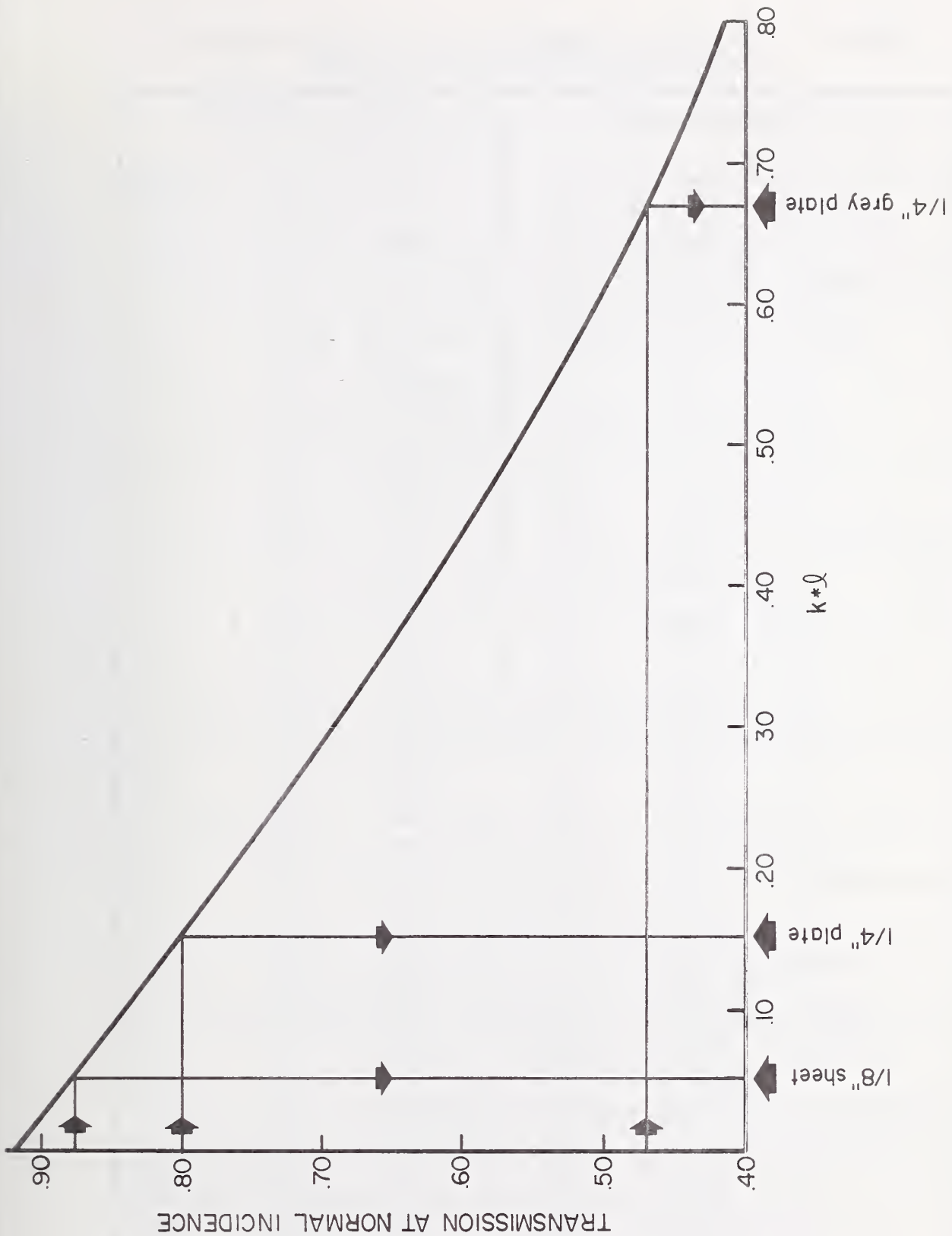

Figure A-5 Transmission at Normal Incidence Versus $k \cdot \lambda$ for Single Sheet Glass

Table A-7 Polynomial Coefficients for Use in Calculation of Transmittance and Absorptance of Glass

| k * v | j | Single Glazing | | Double Glazing | | |
|----------------------------------|---|----------------|----------------|----------------------|----------------------|----------------|
| | | a _j | t _j | a _{j,outer} | a _{j,inner} | t _j |
| 0.05 1/8" Sheet | 0 | 0.01154 | -0.00885 | 0.01407 | 0.00228 | -0.00401 |
| | 1 | 0.77674 | 2.71235 | 1.06226 | 0.34559 | 0.74050 |
| | 2 | -3.94657 | -0.62062 | -5.59131 | -1.19908 | 7.20350 |
| | 3 | 8.57881 | -7.07329 | 12.15034 | 2.22366 | -20.11763 |
| | 4 | -8.38135 | 9.75995 | -11.78092 | -2.05287 | 19.68824 |
| | 5 | 3.01188 | -3.89922 | 4.20070 | 0.72376 | -6.74585 |
| 0.10 | 0 | 0.01636 | -0.01114 | 0.01819 | 0.00123 | -0.00438 |
| | 1 | 1.40783 | 2.39371 | 1.86277 | 0.29788 | 0.57818 |
| | 2 | -6.79030 | 0.42978 | -9.24831 | -0.92256 | 7.42065 |
| | 3 | 14.37378 | -8.98262 | 19.49443 | 1.58171 | -20.26848 |
| | 4 | -13.83357 | 11.51798 | -18.56094 | -1.40040 | 19.79706 |
| | 5 | 4.92439 | -4.52064 | 6.53940 | 0.48316 | -6.79619 |
| 0.15 1/4" Reg. Plate | 0 | 0.01837 | -0.01200 | 0.01905 | 0.00067 | -0.00428 |
| | 1 | 1.92497 | 2.13036 | 2.47900 | 0.26017 | 0.45797 |
| | 2 | -8.89134 | 1.13833 | -11.74226 | -0.72713 | 7.41367 |
| | 3 | 18.40197 | -10.07925 | 24.14037 | 1.14950 | -19.92004 |
| | 4 | -17.48648 | 12.44161 | -22.64299 | -0.97138 | 19.40969 |
| | 5 | 6.17544 | -4.83285 | 7.89954 | 0.32705 | -6.66603 |
| 0.20 | 0 | 0.01902 | -0.01218 | 0.01862 | 0.00035 | -0.00401 |
| | 1 | 2.35417 | 1.90950 | 2.96400 | 0.22974 | 0.36698 |
| | 2 | -10.47151 | 1.61391 | -13.48701 | -0.58381 | 7.27324 |
| | 3 | 21.24322 | -10.64872 | 27.13020 | 0.84626 | -19.29364 |
| | 4 | -19.95978 | 12.83698 | -25.11877 | -0.67666 | 18.75408 |
| | 5 | 6.99964 | -4.95199 | 8.68895 | 0.22102 | -6.43968 |
| 0.40 | 0 | 0.01712 | -0.01056 | 0.01423 | -0.00009 | -0.00279 |
| | 1 | 3.50839 | 1.29711 | 4.14384 | 0.15049 | 0.16468 |
| | 2 | -13.86390 | 2.28615 | -16.66709 | -0.27590 | 6.17715 |
| | 3 | 26.34330 | -10.37132 | 31.30484 | 0.25618 | -15.84811 |
| | 4 | -23.84846 | 11.95884 | -27.81955 | -0.12919 | 15.28302 |
| | 5 | 8.17372 | -4.54880 | 9.36959 | 0.02859 | -5.23666 |
| 0.60 | 0 | 0.01406 | -0.00835 | 0.01056 | -0.00016 | -0.00192 |
| | 1 | 4.15958 | 0.92766 | 4.71447 | 0.10579 | 0.08180 |
| | 2 | -15.06279 | 2.15721 | -17.33454 | -0.15035 | 4.94753 |
| | 3 | 27.18492 | -8.71429 | 30.91781 | 0.06487 | -12.43481 |
| | 4 | -23.88518 | 9.87152 | -26.63898 | 0.02759 | 11.92495 |
| | 5 | 8.03650 | -3.73328 | 8.79495 | -0.02317 | -4.07787 |
| 0.80 50% Trans. H.A. Plate | 0 | 0.01153 | -0.00646 | 0.00819 | -0.00015 | -0.00136 |
| | 1 | 4.55946 | 0.68256 | 5.01768 | 0.07717 | 0.04419 |
| | 2 | -15.43294 | 1.82449 | -17.21228 | -0.09059 | 3.87529 |
| | 3 | 26.70568 | -6.95325 | 29.46388 | 0.00050 | -9.59069 |
| | 4 | -22.87993 | 7.80647 | -24.76915 | 0.06711 | 9.16022 |
| | 5 | 7.57795 | -2.94454 | 8.05040 | -0.03394 | -3.12776 |
| 1.00 | 0 | 0.00962 | -0.00496 | 0.00670 | -0.00012 | -0.00098 |
| | 1 | 4.81911 | 0.51403 | 5.18781 | 0.05746 | 0.02576 |
| | 2 | -15.47137 | 1.47607 | -16.84820 | -0.05878 | 3.00400 |
| | 3 | 25.86516 | -5.41985 | 27.90292 | -0.01855 | -7.33834 |
| | 4 | -21.69106 | 6.05546 | -22.99619 | 0.06837 | 6.98747 |
| | 5 | 7.08714 | -2.28162 | 7.38140 | -0.03191 | -2.38328 |

SHG

An Algorithm for Calculating Solar Heat Gain Through Windows

Data:

- IDN: Intensity of direct normal solar radiation,
Btu per (hr) (sq ft), (Calculated in SUN)
- BS: Sky brightness, Btu per (hr) (sq ft), (Cal-
culated in SUN)
- BG: Ground brightness, Btu per (hr) (sq ft),
(Calculated in SUN)
- $\text{Cos}(\eta)$: Cosine of the angle of incidence of direct
solar radiation, (Calculated in SUN)
- FWS: Form factor between the window and the
sky*
- FWG: Form factor between the window and the
ground*
- RO, RA, RI: Thermal resistances at outside surface,
air space, and inside surface respectively,
(sq ft) (hr) (F) per Btu
- SLA: Sunlit area factor (Calculated in SHADOW)
- SC: Shading coefficient if the window is shaded
by drapes or blinds or if it has an inter-
pane separation of more than 1 inch

* If more accurate data are not available, use $\text{FWS} = \text{FWG} = 0.5$.

NOTE: When the value of SC is given, these transmission and absorption factors should be for the standard 1/8" thick double strength glass (or $k \cdot \rho = 0.05$ of TAR) regardless of the type of glass used.

T_{η} , T_d : Transmission factors for direct and diffuse solar radiation for windows (Calculated in TAR)

$A_{\eta,outer}$, $A_{\eta,inner}$, $A_{d,outer}$, $A_{d,inner}$:
Absorption factors for direct and diffuse solar radiation through outer and inner window panes (Calculated in TAR), respectively

Calculation Sequence:

1. Inward flowing fraction of the radiation absorbed by the inner and the outer pane, respectively.

$$NI = (RO + RA) / (RO + RA + RI)$$

$$NO = RO / (RO + RA + RI)$$

2. Let

$$D = SLA \cdot IDN \cdot \cos(\eta) \cdot (T_{\eta} + NO \cdot A_{\eta,outer} + NI \cdot A_{\eta,inner})$$

$$d = (BS \cdot FWS + BG \cdot FWG) \cdot (T_d + NO \cdot A_{d,outer} + NI \cdot A_{d,inner})$$

3. Solar heat gain through window.

If SC = 0, SHG = D + d

If SC \neq 0, SHG = (SC) * (D + d) $_{k \cdot \rho = 0.05}$

SHADOW

A Brief Description of the Procedures for Calculating External Shadows on a Building

A major portion of the air conditioning load on modern commercial buildings comes from solar radiation. To improve the accuracy of load assessment, it is necessary to know how much of a building is shaded and how much lies exposed to the sun's rays.

A new technique developed by Groth and Lokmanhekim^{4/} employs the representation of all architectural forms as a series of plane polygons. Even curved surfaces can be so represented. For example, a sphere may be approximated by the 20 sides of a regular icosahedron. This approximation gives a maximum error of only 3% in the shadow area cast by the sphere.

The output of the algorithm is not only the sunlit area, but also a pictorial display of the shadows and the surface upon which they are cast.

Coordinate Transformation:

Designate the polygons which cast shadows as shading polygons (SP) and those upon which shadows are cast as receiving polygons (RP). The vertex coordinates of each RP, and its relevant SP's, are transformed from a base coordinate system, xyz , to a new coordinate system, $x'y'z'$, with origin 0 attached to the plane of the RP. The first three vertices,

V_1 , V_2 , and V_3 , of the RP being examined are used to define this new coordinate system. The x' axis passes through V_2 and V_3 , while the y' axis passes through V_1 . In order that the z' axis point outward from the surface, angle $V_1V_2V_3$ must be convex and the vertices must be numbered counterclockwise. The equation of transformation is written in matrix form as

$$\vec{x}' = A (\vec{x} - \vec{x}_0)$$

where

$$\vec{x}_0 = \vec{x}_2 + \gamma(\vec{x}_3 - \vec{x}_2)$$

$$\gamma, A \text{ Scaler} = (\vec{x}_1 - \vec{x}_2) \cdot (\vec{x}_3 - \vec{x}_2) / (\vec{x}_3 - \vec{x}_2) \cdot (\vec{x}_3 - \vec{x}_2)$$

$$\text{1st row of } A = (\vec{x}_3 - \vec{x}_0) / |\vec{x}_3 - \vec{x}_0|$$

$$\text{2nd row of } A = (\vec{x}_1 - \vec{x}_0) / |\vec{x}_1 - \vec{x}_0|$$

$$\text{3rd row of } A = \text{1st row of } A \times \text{2nd row of } A$$

Solar altitude, α , and azimuth, β , must also be transformed, into the solar direction vector, as

$$x'_s = \begin{pmatrix} \text{Sin}\beta \cdot \text{Cos}\alpha \\ \text{Sin}\alpha \\ \text{Cos}\beta \cdot \text{Cos}\alpha \end{pmatrix}$$

Clipping Transformation:

Any part of an SP whose z' is negative cannot cast a shadow on the RP. These "submerged" portions of the SP's must be clipped off, prior to projection, lest they project "false" shadows (see Figure A-6). This

is done by finding, through linear interpolation, the points A and B, on the perimeter of the SP, which pierce the plane of the RP, and taking these points as new vertices. All submerged vertices are deleted. This results in a new polygon with line AB as a side, which will project only real shadows.

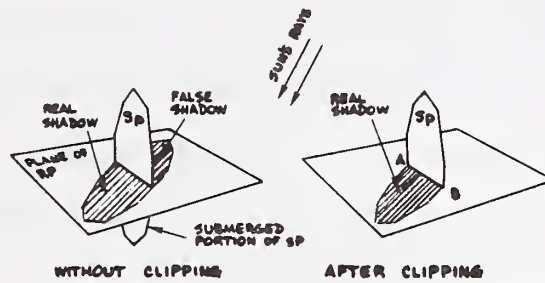

Figure A-6 Clipping

Projection Transformation:

To simulate the actual casting of a shadow, the following transformation projects, along the sun's rays, all the vertex points of the transformed and clipped RP's.

$$X = x' - \frac{x'_s}{z'_s} z'$$

$$Y = y' - \frac{y'_s}{z'_s} z'$$

Enclosure Test:

The coordinate, clipping and projection transformation have converted all RP and SP's in space into two dimensional figures in the RP plane. It remains only to find the points in the RP plane which lie inside the RP and inside one or more of the SP projections, i.e., points of the RP which are shaded. At this point, the two-space XY is divided into a grid and the center of each element of this grid is tested for enclosure by the RP and the SP projections. A point, P, whose coordinates are $X_P Y_P$, is inside of polygon $V_1, V_2, \dots V_n$ if the following inequality holds.

$$\sum_{i=1}^n \Delta\theta_i \neq 0$$

The angular change, $\Delta\theta_i$, subtended at P by the ith side, and counted positive counterclockwise, is given by the following formulae.

$$\Delta\theta_i = \begin{cases} \theta_j - \theta_i & \text{if } |\theta_j - \theta_i| < 2 \\ \frac{(\theta_i - \theta_j)(4 - |\theta_i - \theta_j|)}{|\theta_j - \theta_i|} & \text{if } |\theta_j - \theta_i| \geq 2 \end{cases}$$

$$j = \begin{cases} i + 1 & \text{if } i < n \\ 1 & \text{if } i = n \end{cases}$$

$$\theta_i \sim \begin{array}{ll} \frac{Y_i - Y_P}{X_i - X_P + Y_i - Y_P} & \text{in 1st quadrant} \\ 1 + \frac{X_P - X_i}{X_P - X_i + Y_i - Y_P} & \text{in 2nd quadrant} \\ 2 + \frac{Y_P - Y_i}{X_P - X_i + Y_P - Y_i} & \text{in 3rd quadrant} \\ 3 + \frac{X_i - X_P}{X_i - X_P + Y_P - Y_i} & \text{in 4th quadrant} \end{array}$$

These approximate formulae, which express $\Delta\theta_i$ in right angles, replace the time-consuming square root and are cosine computer library routines. They have, by set theory, been proved adequate for the purpose.

Display Matrix and Sample Problem:

An alphanumeric matrix is created corresponding to the grid elements in the RP plane. A blank component represents a grid element either outside the RP or exposed to the sun. An asterisk component represents a shaded grid element or one on the RP's boundary. Grid elements shaded by a transmissive structure are randomly asterisked with a probability equal to the fraction of incident light stopped by the shading structure. Figure A-7 shows the solution of a typical problem involving a transmissive structure.

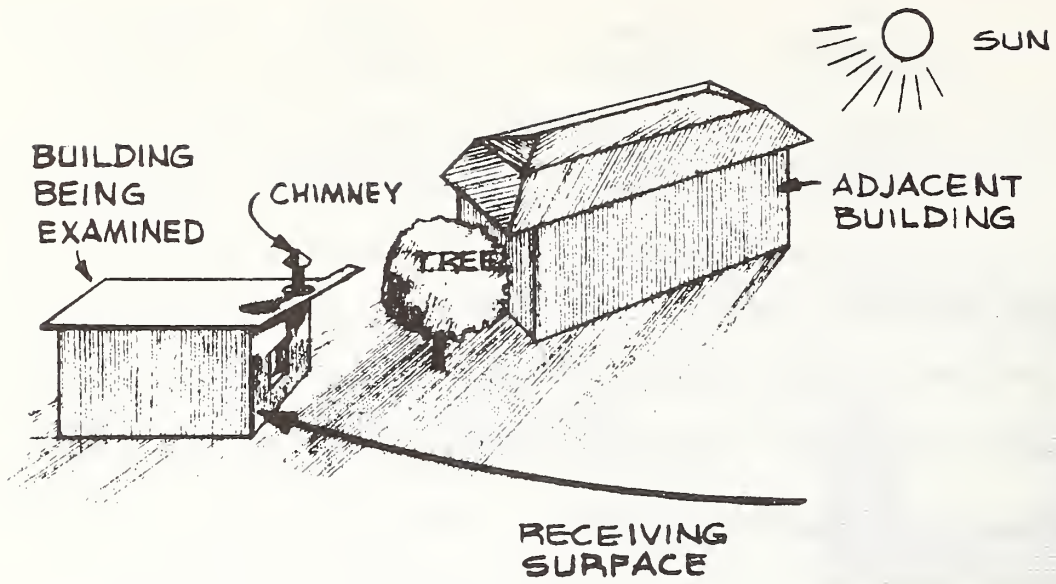

Figure A-7 The Computer Output of a Typical Problem

SHADOW 1*

An Algorithm to Find the Ratio of the Sunlit and Shaded Area
of a Given Window Where the Shadows are Cast by Various
Combinations of Overhang and Side Fins

Data: (Variable names corresponding to the FORTRAN listing
included in this section. Right and left is determined
facing the window from outside - see Figure A-8).

HT: Window height

FL: Window width

FP: Depth of the overhang

AW: Distance from top of the window to the overhang

BWL: Distance of the overhang extended beyond the left edge
of the window

BWR: Distance of the overhang extended beyond the right edge
of the window

D: Depth of vertical projection at the end of the overhang

FP1: Depth of the left fin

A1: Distance of the left fin extended above the top of the
window

B1: Distance from the left edge of the window to the left
fin

C1: Distance of the left fin stop short above the bottom
of the window

FP2: Depth of the right fin

*

This section was contributed by Tseng-Yao Sun; Ayres and Hayakawa,
Los Angeles, California.

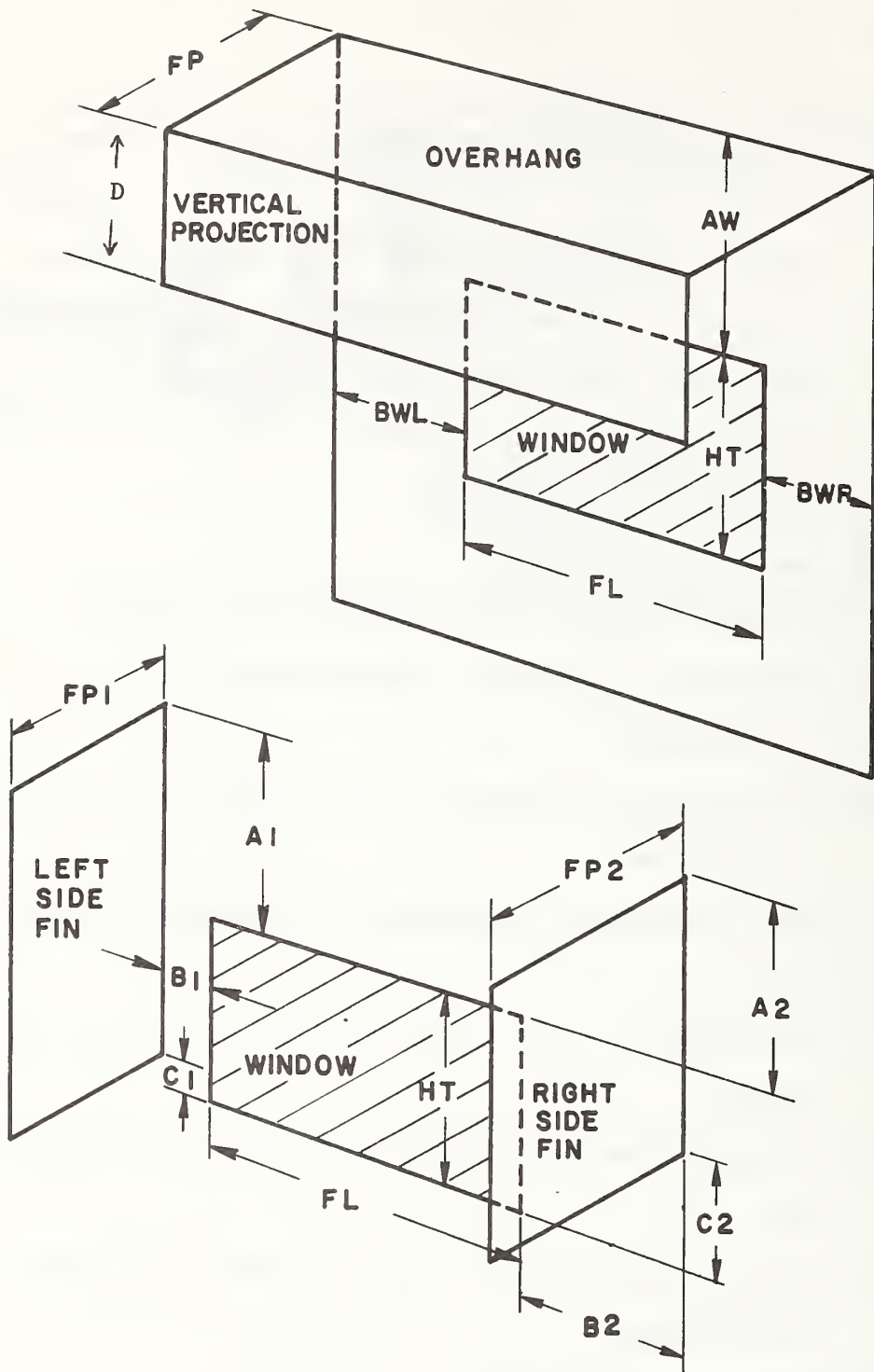

Figure A-8 Shadow 1 Input Data

A2: Distance of the right fin extended above the top of
the window

B2: Distance from the right edge of the window to the
right fin

C2: Distance of the right fin stop short above the bottom
of the window

PHI: Solar azimuth angle

WAZI: Window azimuth angle

COSZ: Cosine of solar zenith angle

Calculation Sequence:

The principle calculation sequence of this subroutine is described in reference 5 and the principle output of the subroutine is the variable SHRAT--the shade ratio or ratio of sunlit area to the total window area. The treatment of shadow overlapping cast by various shading devices is not discussed in the reference but is included in the FORTRAN listing.

```

SUBROUTINE SHADOW(SHDX,PHI,COSZ,SHRAT)
DIMENSION SHDX(20)
HT=SHDX(1)
FL=SHDX(2)
FP=SHDX(3)
AW=SHDX(4)
BWL=SHDX(5)
BWR=SHDX(6)
D=SHDX(7)
FP1=SHDX(8)
A1=SHDX(9)
B1=SHDX(10)
C1=SHDX(11)
FP2=SHDX(12)
A2=SHDX(13)
B2=SHDX(14)
C2=SHDX(15)
WAZI=SHDX(16)
% THIS PROGRAM CALCULATES SHADOW CAST BY OVERHUNG AND SIDE FINNS
% PHI.....SOLAR AZIMUTH ANGLE
% COSZ...COSINE OF SOLAR ZENITH ANGLE
% SHRAT..SHADE RATIO:RATIO OF THE SUNLIT AREA TO THE TOTAL WINDOW AREA
% HT.....WINDOW HEIGHT
% FL.....WINDOW WIDTH
% FP.....DEPTH OF THE OVERHUNG
% AW.....DISTANCE FROM TOP OF THE WINDOW TO THE OVERHUNG
% BWL....DISTANCE OF THE OVERHUNG EXTENDED BEYOND THE LEFT EDGE OF THE WINDOW
% BWR....DISTANCE OF THE OVERHUNG EXTENDED BEYOND THE RIGHT EDGE OF THE WINDOW
% D.....DEPTH OF VERTICAL PROJECTION AT THE END OF THE OVERHUNG
% FP1....DEPTH OF THE LEFT FIN
% A1.....DISTANCE OF THE LEFT FIN EXTENDED ABOVE THE TOP OF THE WINDOW
% B1.....DISTANCE FROM THE LEFT EDGE OF THE WINDOW TO THE LEFT FIN
% C1.....DISTANCE OF THE LEFT FIN STOP SHORT ABOVE THE BOTTOM OF THE WINDOW
% FP2....DEPTH OF THE RIGHT FIN
% A2.....DISTANCE OF THE RIGHT FIN EXTENDED ABOVE THE TOP OF THE WINDOW
% B2.....DISTANCE FROM THE RIGHT EDGE OF THE WINDOW TO THE RIGHT FIN
% C2.....DISTANCE OF THE RIGHT FIN STOP SHORT ABOVE THE BOTTOM OF THE WINDOW
% WAZI...WINDOW AZIMUTH ANGLE
SHRAT=1.
1103 A=AW
      H=HT
      GAMMA=PHI-WAZI
      COSG=COS(GAMMA)
      IF(COSG)100,100,104
100  SHRAT=0.
      GO TO 2000
104  CONTINUE
      SBETA=COSZ
      IF(SBETA)100,100,152
152  SING=SIN(GAMMA)
      VERT=SBETA/SQRT(1.-SBETA*SBETA)/COSG
      HORIZ=ABS(SING)/COSG
      TCETA=VERT/HORIZ

```

```

IF(GAMMA) 155,154,154
% -----SUN ON LEFT
154 B=BWL
GO TO 156
% -----SUN ON RIGHT
155 B=BWR
156 ARSHF=0.
AREAV=0.
ARSIF=0.
AREA0=0.
AREA1=0.
ARSH1=0.
FL3=0.
H3=0.
H1=H
FL1=FL
K=1
L=1
T1=FP*VERT
FM1=FP*HORIZ
IF(FP) 37,37,153
153 T=T1
FM=FM1
AB=B*TCETA
UG=(FL+B)*TCETA
DE=(H+A)/TCETA
% -----HORIZONTAL OVERHUNG "AREA0"
IF(T-A) 27,27,2
2 IF(AB-A) 14,14,3
3 IF(DE-B) 12,12,4
4 IF(FM-B) 11,11,5
5 IF(DE-(FL+B)) 8,8,6
6 IF(FM-(FL+B)) 9,7,7
% -----HORIZ 9
7 AREA0=FL*(0.5*(AB+UG)-A)
GO TO 37
8 IF(T-(H+A)) 9,10,10
% -----HORIZ 7
9 AREA0=(T-A)*FL-((FM-B)**2)*TCETA*0.5
L=2
GO TO 21
% -----HORIZ 8
10 AREA0=H*FL-(DE-B)**2*TCETA*0.5
GO TO 37
% -----HORIZ 3
11 AREA0=FL*(T-A)
L=2
GO TO 24
12 IF(T-(H+A)) 11,13,13
% -----HORIZ 2
13 AREA0=H*FL
GO TO 68
14 IF(UG-A) 27,27,15
15 IF(DE-(FL+B)) 18,18,16

```

```

16 IF (FM-(FL+B)) 20,17,17
% -----HORIZ 6
17 AREA0=(UG-A)**2/TCETA*0.5
GO TO 37
18 IF (T-(H+A)) 20,19,19
% -----HORIZ 5
19 AREA0=H*(FL-(A+0.5*H)/TCETA+B)
GO TO 37
% -----HORIZ 4
20 AREA0=(T-A)*(FL+B-FM*(1.+A/T))*0.5)
L=2
% -----VERT PROJ "AREAV"
21 FL3=FL+B-FM
IF (T+D-(H+A)) 22,22,23
% -----VERT 8
22 H3=D
GO TO 3700
% -----VERT 9
23 H3=H+A-T
GO TO 3700
24 FL3=FL
IF (T+D-(H+A)) 26,26,25
% -----VERT 7
25 H3=H+A-T
AREAV=H3*FL3
GO TO 68
% -----VERT 6
26 H3=D
GO TO 3700
27 IF (T+D-A) 37,37,28
28 IF (FM-B) 34,34,29
29 IF (FM-(FL+B)) 31,37,37
31 FL3=FL+B-FM
IF (T+D-(H+A)) 33,33,32
% -----VERT 5
32 H3=H
GO TO 3700
% -----VERT 4
33 H3=T+D-A
GO TO 3700
34 IF (T+D-(H+A)) 36,35,35
% -----VERT 2
35 AREAV=H*FL
GO TO 68
% VERT 3
36 H3=T+D-A
FL3=FL
3700 AREAV=FL3*H3
% -----SIDE FIN AND SHORT SIDE FIN
% -----SIDE FIN "AREA1" "ARSIF"
37 IF (GAMMA) 66,68,74
74 FPF=FP1
AF=A1
BF=B1

```

```

CX=C1
GO TO 84
66 FPF=FP2
AF=A2
BF=B2
CX=C2
84 IF (FPF) 68,68,67
67 T=FPF*VERT
FM=FPF*HORIZ
AF1=AF
IF (AREA0) 73,73,88
% -----TEST FOR OVERLAP OF FIN AND OVERHUNG SHADOW
88 AT=A+(BF-B)*TCETA
IF (AT-AF) 711,73,73
% -----OVERLAP EXISTS..L=2 IF OVERHUNG SHADOW HAS HORIZ EDGE IN WINDOW
711 GO TO (621,712),L
% -----TEST FOR TYPE OF OVERLAP
712 IF ((FM-BF)-(FM1-B)) 621,622,622
% -----SET L=1,SHADOW INTERSECT ON INCLINED EDGE OF OVERHUNG SHADOW
% -----FIN SHADOW IS BELOW INCLINED EDGE OF OVERHUNG SHADOW
621 AF=AT
L=1
GO TO 73
% -----L IS 2, HORIZ EDGE OF OVERHUNG SHADOW-PORION ABOVE HORIZ EDGE
% -----NOT IN OVERHUNG SHADOW IS FIN SHADOW
622 AREA1=FL*(T1-A)-AREA0
% -----RESET TO CALC FIN SHADOW BELOW HORIZ EDGE OF OVHNG SHADOW
AF=T1-A+AF1
H=H+AF1-AF
% -----SHADOW OF FIN (K=1 ON GLASS K=2 ON VERT PROJ SHADOW)
73 AB=BF*TCETA
UG=(FL+BF)*TCETA
DE=(H+AF)/TCETA
DJ=CX/TCETA
IF (FM-BF) 69,69,38
38 IF (AB-AF) 39,50,50
39 IF (UG-AF) 48,48,40
40 IF (T-AF) 47,47,41
41 IF (UG-(H+AF)) 44,44,42
42 IF (T-(H+AF)) 91,80,80
% -----FIN 9
80 AREA1=H*((AF+H*0.5)/TCETA-BF)+AREA1
GO TO 58
44 IF (FM-(FL+BF)) 91,89,89
% -----FIN8
89 AREA1=H*FL-(UG-AF)**2/TCETA*0.5+AREA1
GO TO 58
% -----FIN 7
91 AREA1=(FM-BF)*H-(T-AF)**2/TCETA*0.5+AREA1
GO TO 63
48 IF (FM-(FL+BF)) 47,47,49
% -----FIN 3
47 AREA1=H*(FM-BF)+AREA1
GO TO 63

```

```

% -----FIN 2
49 AREA1=H*FL+AREA1
GO TO 58
50 IF (DE-BF) 69,69,51
51 IF (UG-(H+AF)) 55,55,52
52 IF (T-(H+AF)) 93,94,94
% -----FIN 6
94 AREA1=(DE-BF)**2*TCETA*0.5+AREA1
GO TO 58
% -----FIN 4
93 AREA1=(FM-BF)*(H+AF-(T+AB)*0.5)+AREA1
GO TO 63
55 IF (FM-(FL+BF)) 93,99,99
% -----FIN 5
99 AREA1=FL*(H-(BF+FL*0.5)*TCETA+AF)+AREA1
% -----SHORT SIDE FIN "ARSH1","ARSHF"
58 IF (DJ-BF) 69,69,59
59 IF (DJ-(FL+BF)) 61,61,60
% -----SHORT 3
60 ARSH1=-FL*(CX-(BF+FL/2.)*TCETA)
GO TO 69
% -----SHORT 4
61 ARSH1=-(CX-AB)**2/TCETA*0.5
GO TO 69
63 IF (DJ-BF) 69,69,64
64 IF (DJ-FM) 61,61,65
% -----SHORT 2
65 ARSH1=-(FM-BF)*(CX-(T+AB)*0.5)
69 GO TO (77,76),K
76 ARSH1=-ARSH1
AREA1=-AREA1
77 ARSHF=ARSHF+ARSH1
ARSIF=ARSIF+AREA1
GO TO (78,68),K
78 IF (AREAV) 68,68,72
% -----RESET PARAMETERS TO DEDUCT FIN SHADOW OVERLAP ON VERT PROJ SHADOW
72 K=2
AREA1=0.
ARSH1=0.
BBF=BF
BF=FM1-B+BF
IF (BF) 186,185,185
186 BF=BBF
185 IF (HT+A-T1-D) 87,87,188
188 CX=CX-(HT+A-T1-D)
IF (CX) 85,87,87
85 CX=0.
87 AF=T1-A+AF
H=H3
FL=FL3
GO TO 73
% ----- SHADED AREA "ARSHA"
68 ARSHA=AREA0+AREAV+ARSHF+ARSIF
SHRAT=(FL1*H1-ARSHA)/(FL1*H1)

```

2000 FL=FL1
CONTINUE
RETURN
END

SHADOW 2*

An Algorithm to Determine Whether or Not a Given Window is Shaded by a Remote Object Such as an Adjacent Building

This algorithm is approximate and is applicable only where the window is relatively small in comparison to the shading object. Large windows may be subdivided into smaller segments for this consideration. The window is considered either completely shaded or completely in sun. Partially shaded window can be considered in either case depending on the location of the window reference point. Figure A-9 shows a typical window-shading object relationship.

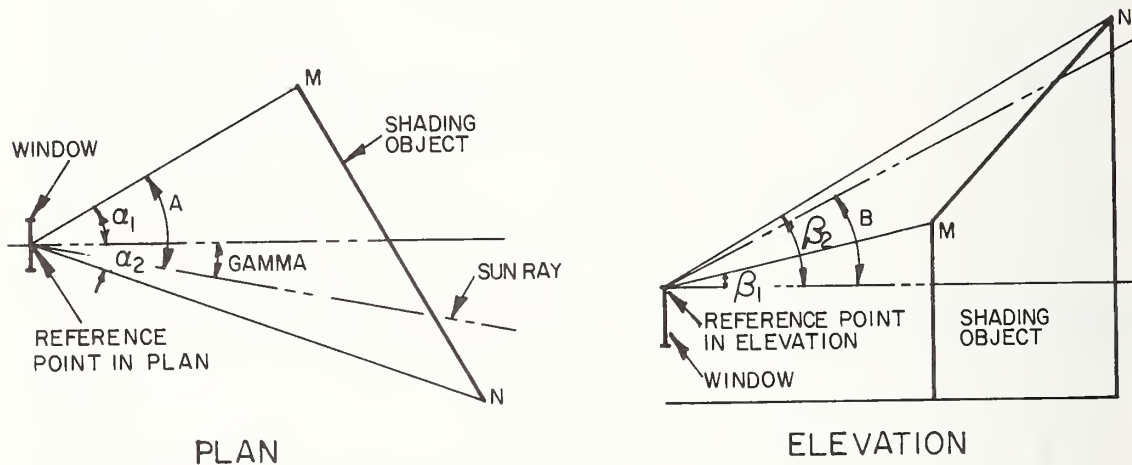

Figure A-9 A Typical Window-Shading Object Relationship

Note that the reference point can be located at any point on the window. Locating the reference point at the top of the window as shown in the elevation in Figure A-9 is slightly conservative as compared to if the reference point is located at the center of the window.

* This section was contributed by Tseng-Yao Sun; Ayres, Cohen and Hayakawa, Los Angeles, California.

Data:

α_1, α_2 : Azimuth shadow limit angles. Right +, Left -

β_1, β_2 : Altitude shadow limit angles

WAZI: Window azimuth angle

PHI: Solar azimuth angle

BETA: Solar altitude angle

Calculation Sequence:

This subroutine determines whether the window is sunlit or shaded for the given position of the sun.

1. Wall-solar azimuth angle

$$\text{GAMMA} = \text{PHI} - \text{WAZI}$$

2. If $\text{GAMMA} < \alpha_1$ or $\text{GAMMA} > \alpha_2$, the window is in sun

3. If $\alpha_2 > \text{GAMMA} > \alpha_1$,

$$A = \text{GAMMA} - \alpha_1$$

$$B = \beta_1 + A * (\beta_2 - \beta_1)$$

4. If $\text{BETA} > B$, the window is in sun. Otherwise, the window is in shade.

An Algorithm for Calculating Radiation Shape Factors
Between Inside Surfaces of a Room

Definition of Room

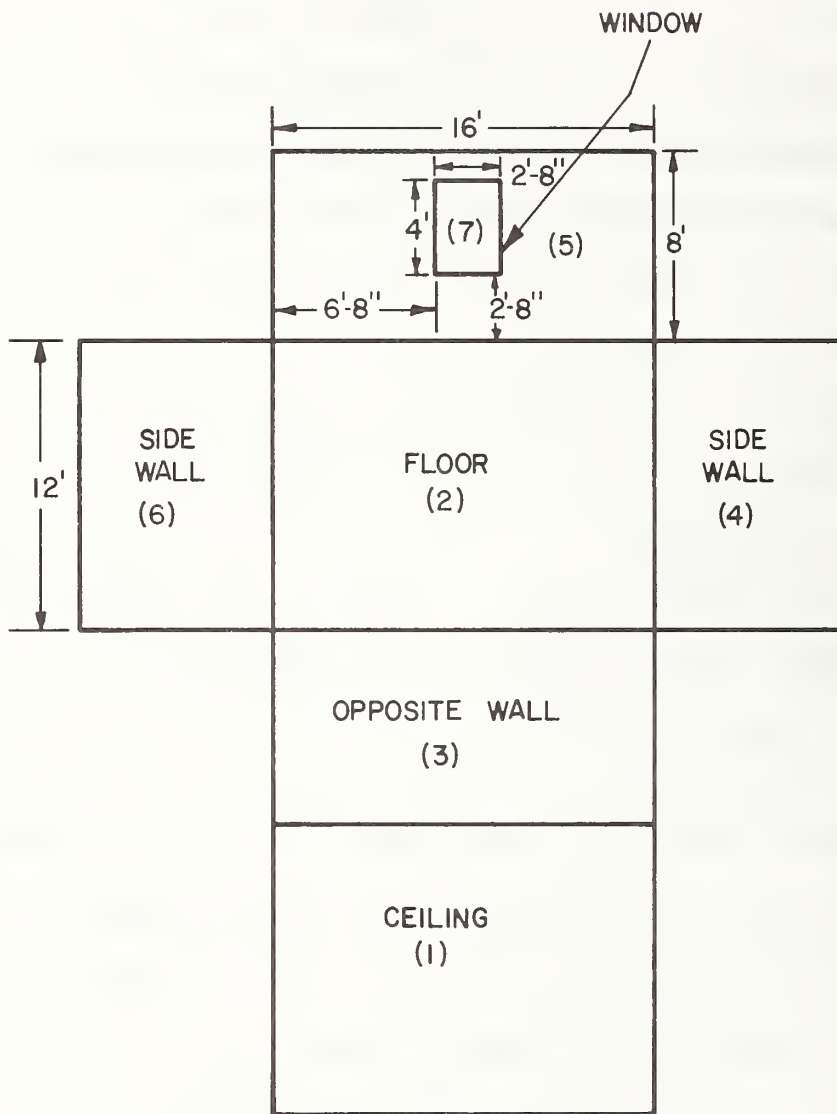

Figure A-10 Room Layout

* This section was contributed by D. M. Burch and B. A. Peavy; Thermal Engineering Systems Section, Center for Building Technology, National Bureau of Standards, Washington, D. C.

Data:

- L: Length of room
- W: Width of room
- H: Height of room
- A: Height of windows or doors
- B: Width of windows or doors
- C: Distance of left edge of window from left wall
- D: Height of lower edge of window from floor

The primary variables determined by this subroutine are:

F_{m-n} : An array giving radiation shape factors between the various inside surfaces of a room

- m,n = 1 Ceiling
- 2 Floor
- 3 Wall No. 1 (length by height)
- 4 Wall No. 2 (side wall)
- 5 Wall No. 3 (opposite wall)
- 6 Wall No. 4 (side wall)
- 7-14 Provision for windows and doors in walls

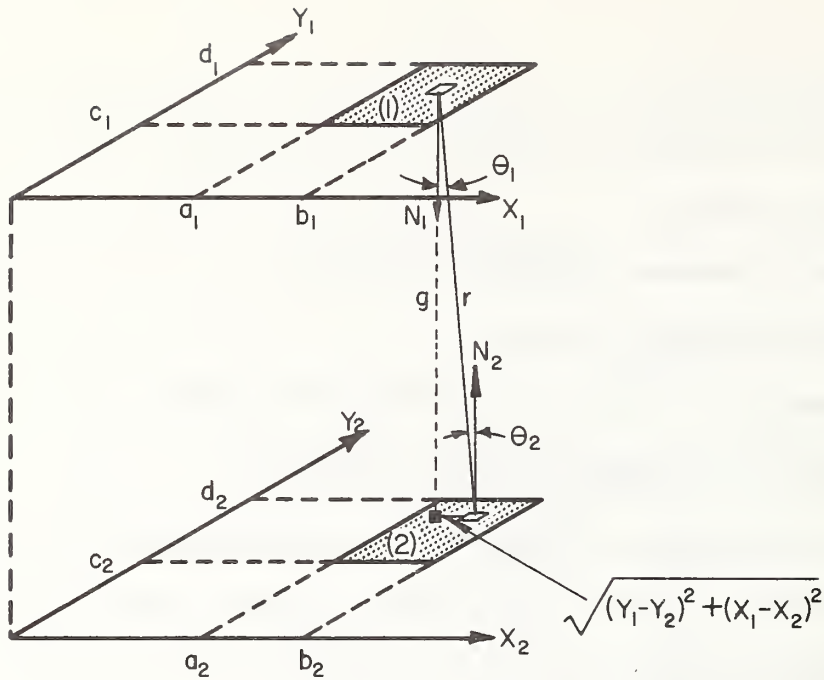

Figure A-11 Radiation Heat Exchange Between Ceiling and Floor Surfaces

Radiation shape factor, F_{1-2} , between two parallel room surfaces

$$2\pi(b_1 - a_1)(d_1 - c_1)F_{1-2} = [P(b_2 - b_1) + P(a_2 - a_1)] [Q(c_2 - c_1) + Q(d_2 - d_1) - Q(c_2 - d_1) - Q(d_2 - c_1)] \\ + [P(b_2 - a_1) + P(a_2 - b_1)] [Q(c_2 - d_1) + Q(d_2 - c_1) - Q(c_2 - c_1) - Q(d_2 - d_1)]$$

where

$$P(Z_1)Q(Z_2) = Z_1 W \tan^{-1} \frac{Z_1}{W} + Z_2 V \tan^{-1} \frac{Z_2}{V} - \frac{G^2}{Z} \ln \left(\frac{W^2 + Z_1^2}{W^2} \right)$$

$$V^2 = G^2 + Z_1^2, \quad W^2 = G^2 + Z_2^2$$

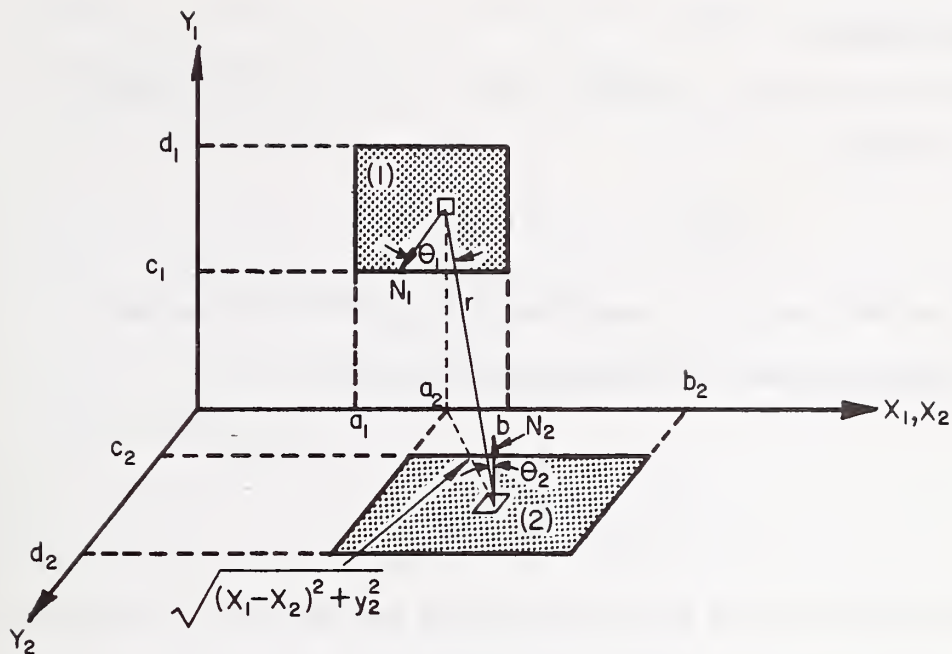

Figure A-12 Radiation Heat Exchange Between Wall and Floor Surfaces

Radiation Shape Factor, F_{1-2} , between two perpendicular room surfaces

$$2\pi(b_1-a_1)(d_1-c_1)F_{1-2} = [R(b_2-b_1)+R(a_2-a_1)] [S(c_2-c_1)+S(d_2-d_1)-S(c_2-d_1)-S(d_2-c_1)] \\ + [R(b_2-a_1)+R(a_2-b_1)] [S(c_2-d_1)+S(d_2-c_1)-S(c_2-c_1)-S(d_2-d_1)]$$

where

$$R(Z_1)S(Y_2+Y_1) = TZ_1 \tan^{-1} \frac{Z_1}{T} + \frac{1}{4} (Z_1 \frac{Z_1}{T^2}) \ln (T^2+Z_1^2)$$

$$T^2 = Y_2^2 + Y_1^2$$

Calculation Sequence:

1. Determine areas of ceiling, floor, and walls (no windows or doors),

$$A_m, m = 1, 2, 3, 4, 5, 6$$

2. Calculate radiation shape factor F_{m-n} for these surfaces using equations, and reciprocal relation

$$F_{m-n} = \frac{A_n}{A_m} F_{n-m}$$

3. Determine area of windows and doors and subtract from pertinent wall areas to give net wall areas.
4. Calculate radiation shape factors from windows and/or doors to ceiling and/or floor using the above shape factor equations and the reciprocal relation. The radiation shape factors from a ceiling or floor surface to a window, door, or a wall area is given by

$$F_{m-n_k} = F_{m-n} - F_{m-n_1} - F_{m-n_2}$$

where k denotes the surface which is applicable for a receiving surface, A_n that has been subdivided into 2 or more surfaces.

5. Calculate radiation shape factors from windows and doors to walls using equations, above defined angle factor algebra and

$$A_{m_k} F_{m_k-n} = A_m F_{m-n} - A_{m_1} F_{m_1-n} - A_{m_2} F_{m_2-n}$$

which is applicable for a transmitting surface A_m that has been subdivided into 2 or more surfaces.

6. The resulting array F_{m-n} must be satisfied by the identity

$$\sum_{k=1}^p F_{m-k} = 1$$

where p is the number of surfaces visible to the transmitting surface A_m .

C THIS PROGRAM DETERMINES THE RADIATION SHAPE FACTORS FOR A ROOM
 C OF ARBITRARY DIMENSIONS WITH THE PROVISION FOR TWO WINDOWS OR
 C DOORS OF ANY SIZE AND POSITION ON EACH OF THE FOUR WALLS
 C INPUT TO THE PROGRAM IS READ IN FIELDS OF NINE AND FIRST CARD IS

C LENGTH WIDTH HEIGHT

C THIS CARD IS FOLLOWED BY FOUR CARDS GIVING PERTINENT DIMENSIONS
 C FOR WINDOWS AND DOORS - FIRST CARD IS FOR WINDOWS OR DOORS ON A
 C WALL DEFINED ON THE LENGTH OF ROOM - SECOND CARD ON WIDTH, ETC.
 C LEAVE SPACES BLANK IF THERE IS NO WINDOW OR DOOR

| | | | | | | | | |
|---|---|---|---|---|---|---|---|---|
| C | A | B | C | D | A | B | C | D |
| C | A | B | C | D | A | B | C | D |
| C | A | B | C | D | A | B | C | D |
| C | A | B | C | D | A | B | C | D |

C WHERE A=HEIGHT OF WINDOW, C=CORNER OF WALL TO LEFT EDGE OF WINDOW
 C B=WIDTH OF WINDOW, D=HEIGHT FROM FLOOR TO LOWER EDGE OF WINDOW
 C OUTPUT CONSISTS OF ASSIGNMENT OF NUMBERS TO THE VARIOUS SURFACES
 C OF THE ROOM

| | | | |
|---|------|-----------------------------|-----------------|
| C | 1 | CEILING | LENGTH X WIDTH |
| C | 2 | FLOOR | LENGTH X WIDTH |
| C | 3 | WALL NO.1 | LENGTH X HEIGHT |
| C | 4 | WALL NO.2 | WIDTH X HEIGHT |
| C | 5 | WALL NO.3 | LENGTH X HEIGHT |
| C | 6 | WALL NO.4 | WIDTH X HEIGHT |
| C | 7-14 | WINDOW OR DOOR ON WALL NO.X | |

C THIS IS FOLLOWED BY A PRINTOUT OF AN ARRAY OF RADIATION SHAPE FACTORS
 C DIMENSION SF(14,14),A(8),B(8),C(8),D(8),S(14),X(5)
 C DIMENSION IFIL(14),VF(14,14)
 C REAL L

READ(5,1)L,W,H
 READ(5,1)(B(I),D(I),A(I),C(I),I=1,8)

1 FORMAT(8F9.2)
 301 FORMAT(6X,28H LEGEND FOR ROOM ARRANGEMENT/40HDASSUME WALL NO. 1 I
 1S ON THE ROOM LENGTH/7HOM OR N/4H 1,6X,10H CEILING ,F6.2,4H BY
 2,F6.2/4H 2,6X,10H FLOOR ,F6.2,4H BY ,F6.2/4H 3,6X,10H WALL
 3NO.1,F6.2,4H BY ,F6.2/4H 4,6X,10H WALL NO.2,F6.2,4H BY ,F6.2/4H
 4 5,6X,10H WALL NO.3,F6.2,4H BY ,F6.2/4H 6,6X,10H WALL NO.4,F6.2
 5,4H BY ,F6.2)

403 FORMAT(I4,6X,15H DOOR ON WALL,I2,4F11.2)
 302 FORMAT(I4,6X,15H WINDOW ON WALL,I2,4F11.2)
 303 FORMAT(6X,17H WINDOWS OR DOORS,13X,2H A,9X,2H B,9X,2H C,9X,2H D)
 304 FORMAT(1H /8X,18H A - WINDOW HEIGHT/8X,17H B - WINDOW WIDTH/9X,4AH
 1C - DISTANCE OF LEFT EDGE OF WINDOW TO LEFT WALL/8X,46H D - HEIGHT
 2 FROM FLOOR TO LOWER EDGE OF WINDOW)

WRITE (6,301) L,W,L,W,L,H,W,H,L,H,W,H
 WRITE (6,303)

K=7
 DO 305 I=1,8
 IF(D(I).LT.1.E-8) GO TO 305

J=(I+1)/2
 IC=C(I)*100.
 IF(IC.EQ.0)GO TO 401
 WRITE(6,302)K,J,D(I),B(I),A(I),C(I)
 GO TO 402

401 WRITE(6,403)K,J,D(I),B(I),A(I),C(I)
 402 CONTINUE
 K=K+1

```

305 CONTINUE
WRITE(6,304)
DO 26 I=1,8
26. B(I)=A(I)+B(I)
D(I)=C(I)+D(I)
S(1)=W*L
S(2)=S(1)
DO 15 I=1,8
S(I+6)=(B(I)-A(I))*(D(I)-C(I))
IA=S(I+6)
IF(IA.EQ.0)S(I+6)=1.0E-08
15 CONTINUE
DO 14 I=1,5
VAR=L
IF(I.EQ.2.OR.I.EQ.4)VAR=W
14 X(I)=VAR
DO 25 I=1,4
IW=(I-1)*2+7
25 S(I+2)=X(I)*H
DO 2 I=1,14
DO 2 J=1,14
2 SF(I,J)=0.0
SF(1,2)=PF(0.0,L,0.0,W,0.0,L,0.0,W,H)
SF(1,3)=AF(0.0,L,0.0,W,0.0,L,0.0,H)
SF(1,4)=AF(0.0,W,0.0,L,0.0,W,0.0,H)
SF(1,5)=SF(1,3)
SF(1,6)=SF(1,4)
SF(2,1)=SF(1,2)*S(1)/S(2)
SF(2,3)=SF(1,3)
SF(2,4)=SF(1,4)
SF(2,5)=SF(2,3)
SF(2,6)=SF(2,4)
SF(3,1)=SF(1,3)*S(1)/S(3)
SF(3,2)=SF(2,3)*S(2)/S(3)
SF(3,4)=AF(0.0,H,0.0,L,0.0,H,0.0,W)
SF(3,5)=PF(0.0,L,0.0,H,0.0,L,0.0,H,W)
SF(3,6)=SF(3,4)
SF(4,1)=SF(1,4)*S(1)/S(4)
SF(4,2)=SF(2,4)*S(2)/S(4)
SF(4,3)=SF(3,4)*S(3)/S(4)
SF(4,5)=SF(4,3)
SF(4,6)=PF(0.0,W,0.0,H,0.0,W,0.0,H,L)
SF(5,1)=SF(1,5)*S(1)/S(5)
SF(5,2)=SF(2,5)*S(2)/S(5)
SF(5,3)=SF(3,5)*S(3)/S(5)
SF(5,4)=SF(4,5)*S(4)/S(5)
SF(5,6)=SF(5,4)
SF(6,1)=SF(1,6)*S(1)/S(6)
SF(6,2)=SF(2,6)*S(2)/S(6)
SF(6,3)=SF(3,6)*S(3)/S(6)
SF(6,4)=SF(4,6)*S(4)/S(6)
SF(6,5)=SF(5,6)*S(5)/S(6)
DO 250 I=1,4
IW=(I-1)*2+7
250 S(I+2)=S(I+2)-S(IW)-S(IW+1)
DO 3 K=1,4
J=(K-1)*2
DO 5 I=1,2
N=I+J
N6=N+6
SF(N6,2)=AF(A(N),B(N),C(N),D(N),0.0,X(K),0.0,X(K+1))
SF(N6,1)=AF(A(N),B(N),H-D(N),H-C(N),0.0,X(K),0.0,X(K+1))

```

```

5 SF(2,N6)=SF(N6,2)*S(N6)/S(2)
SF(1,N6)=SF(N6,1)*S(N6)/S(1)
SF(2,2+K)=SF(2,2+K)-SF(2,J+7)-SF(2,J+8)
SF(1,2+K)=SF(1,2+K)-SF(1,J+7)-SF(1,J+8)
3 SF(2+K,2)=SF(2,2+K)*S(2)/S(2+K)
SF(2+K,1)=SF(1,2+K)*S(1)/S(2+K)
DO 8 K=1,2
N=(K-1)*2
SUM=0.0
DO 6 J=1,2
NJ=N+J
NJ6=NJ+6
SF(NJ6,K+4)=PF(A(NJ),B(NJ),C(NJ),D(NJ),0.0,X(K),0.0,H,X(K+1))
SUM=SUM+S(NJ6)*SF(NJ6,K+4)
DO 6 I=1,2
NI=N+I+4
NI6=NI+6
SF(NJ6,NI6)=PF(A(NJ),B(NJ),C(NJ),D(NJ),X(K)-B(NI),X(K)-A(NI),C(NI)
1,D(NI),X(K+1))
6 SF(NI6,NJ6)=SF(NJ6,NI6)*S(NJ6)/S(NI6)
DO 7 I=1,2
NI=N+I+4
NI6=NI+6
7 SF(NI6,K+2)=PF(A(NI),B(NI),C(NI),D(NI),0.0,X(K),0.0,H,X(K+1))
SF(N+7,K+4)=SF(N+7,K+4)-SF(N+7,N+11)-SF(N+7,N+12)
SF(N+8,K+4)=SF(N+8,K+4)-SF(N+8,N+11)-SF(N+8,N+12)
SF(N+11,K+2)=SF(N+11,K+2)-SF(N+11,N+7)-SF(N+11,N+8)
SF(N+12,K+2)=SF(N+12,K+2)-SF(N+12,N+7)-SF(N+12,N+8)
SF(K+4,N+7)=SF(N+7,K+4)*S(N+7)/S(K+4)
SF(K+4,N+8)=SF(N+8,K+4)*S(N+8)/S(K+4)
SF(K+2,N+11)=SF(N+11,K+2)*S(N+11)/S(K+2)
SF(K+2,N+12)=SF(N+12,K+2)*S(N+12)/S(K+2)
SF(K+2,K+4)=(X(K)+H*SF(K+2,K+4)-SUM)/S(K+2)
SF(K+2,K+4)=SF(K+2,K+4)-SF(K+2,N+11)-SF(K+2,N+12)
8 SF(K+4,K+2)=SF(K+2,K+4)*S(K+2)/S(K+4)
DO 9 K=1,4
IT=K+3
IF(K.EQ.4)IT=3
IW=(K-1)*2
SUM=0.0
DO 10 I=1,2
IK=IW+I
IK6=IK+6
SF(IK6,IT)=AF(C(IK),D(IK),X(K)-B(IK),X(K)-A(IK),0.0,H,0.0,X(K+1))
SUM=SUM+S(IK6)*SF(IK6,IT)
DO 10 J=1,2
IM=J+IW+2
IF(K.EQ.4)IM=J
IM6=IM+6
SF(IK6,IM6)=AF(C(IK),D(IK),X(K)-B(IK),X(K)-A(IK),C(IM),D(IM),A(IM)
1,B(IM))
10 SF(IM6,IK6)=SF(IK6,IM6)*S(IK6)/S(IM6)
DO 11 I=1,2
IL=IW+2+I
IF(K.EQ.4)IL=I
IL6=IL+6
11 SF(IL6,K+2)=AF(C(IL),D(IL),A(IL),B(IL),0.0,H,0.0,X(K))
IW7=IW+7
IAC=IW7+2
IWL=K+3
IF(K.NE.4)GO TO 12
IWL=3
IAC=7

```

```

12  IK=K+2
    SF(IW7,IWL)=SF(IW7,IWL)-SF(IW7,IAC)-SF(IW7,IAC+1)
    SF(IW7+1,IWL)=SF(IW7+1,IWL)-SF(IW7+1,IAC)-SF(IW7+1,IAC+1)
    SF(IAC,IK)=SF(IAC,IK)-SF(IAC,IW7)-SF(IAC,IW7+1)
    SF(IAC+1,IK)=SF(IAC+1,IK)-SF(IAC+1,IW7)-SF(IAC+1,IW7+1)
    SF(IWL,IW7)=SF(IW7,IWL)*S(IW7)/S(IWL)
    SF(IWL,IW7+1)=SF(IW7+1,IWL)*S(IW7+1)/S(IWL)
    SF(IK,IAC)=SF(IAC,IK)*S(IAC)/S(IK)
    SF(IK,IAC+1)=SF(IAC+1,IK)*S(IAC+1)/S(IK)
    KAC=IK+1
    IF(K.EQ.4)KAC=3
    SF(IK,KAC)=(X(K)*H*SF(IK,KAC)-SUM)/S(IK)
    SF(IK,KAC)=SF(IK,KAC)-SF(IK,IAC)-SF(IK,IAC+1)
9   SF(KAC,IK)=SF(IK,KAC)*S(IK)/S(KAC)
    NP=0
    DO 52 I=1,14
    IB=SF(I,1)*1000.
    IF(I.EQ.1)IB=1
    IF(IB.EQ.0)GO TO 52
    NP=NP+1
    IFIL(NP)=I
52  CONTINUE
    DO 16 I=1,NP
    DO 16 J=1,NP
    NI=IFIL(I)
    NJ=IFIL(J)
16  VF(I,J)=SF(NI,NJ)
    WRITE(6,307)
307  FORMAT(1H /4X,44H AFRAY FOR SHAPE FACTORS FROM SURFACE M TO N/1H )
17  WRITE(6,17)(I,I=1,NP)
    FORMAT(4H M/N, I5,13I7)
    DO 18 I=1,NP
18  WRITE(6,19)(I,(VF(I,J),J=1,NP))
19  FORMAT(1X,I2,1X,14F7.5)
    STOP
    END

```

```

FUNCTION PF(A1,B1,C1,D1,A2,B2,C2,D2,G)
C   THIS FUNCTION SUBPROGRAM CALCULATES THE SHAPE FACTOR FROM A
C   PLANE RECTANGULAR SURFACE TO ANOTHER PARALLEL PLANE
C   RECTANGULAR SURFACE.
    S=(B1-A1)*(D1-C1)
    IP=S*10.
    IF(IP.NE.0)GO TO 1
    PF=0.0
    RETURN
1   F=F1(B1,D1,B2,D2,G)-F1(B1,D1,B2,C2,G)
    1-F1(B1,D1,A2,D2,G)+F1(B1,D1,A2,C2,G)
    2-F1(H1,C1,B2,D2,G)+F1(B1,C1,B2,C2,G)
    3+F1(B1,C1,A2,D2,G)-F1(B1,C1,A2,C2,G)
    4-F1(A1,D1,B2,D2,G)+F1(A1,D1,B2,C2,G)
    5+F1(A1,D1,A2,D2,G)-F1(A1,D1,A2,C2,G)
    6+F1(A1,C1,B2,D2,G)-F1(A1,C1,B2,C2,G)
    7-F1(A1,C1,A2,D2,G)+F1(A1,C1,A2,C2,G)
    PF=F/(3.1415927*S)
    RETURN
END

```

```

FUNCTION F1(X1,Y1,X2,Y2,G)
U=X2-X1
V=Y2-Y1
UU=SQRT(G*G+U*U)
VV=SQRT(G*G+V*V)
WW=(G*G+U*U+V*V)/(G*G+V*V)
FI=U*VV*ATAN(U/VV)+V*UU*ATAN(V/UU)-G*G*LOG(WW)/2.
F1=FI/2.
RETURN
END

```

```

C      FUNCTION AF(A1,B1,C1,D1,A2,B2,C2,D2)
C      THIS FUNCTION SUBPROGRAM CALCULATES THE SHAPE FACTOR FROM A
C      PLANE RECTANGULAR SURFACE OF A ROOM TO ANOTHER PERPENDICULAR
C      PLANE RECTANGULAR SURFACE.
      S=(B1-A1)*(D1-C1)
      IP=S*10.
      IF(IP.NE.0) GO TO 1
      AF=0.0
      RETURN
1     F=F2(A1,C1,A2,C2)+F2(B1,D1,B2,D2)
      1-F2(A1,D1,B2,D2)-F2(B1,D1,B2,C2)
      2+F2(A1,D1,B2,C2)-F2(B1,D1,A2,D2)
      3+F2(A1,D1,A2,D2)+F2(B1,D1,A2,C2)
      4-F2(A1,D1,A2,C2)-F2(B1,C1,B2,D2)
      5+F2(A1,C1,B2,D2)+F2(B1,C1,B2,C2)
      6-F2(A1,C1,B2,C2)+F2(B1,C1,A2,D2)
      7-F2(A1,C1,A2,D2)-F2(B1,C1,A2,C2)
      AF=F/(3.1415927*S)
      RETURN
END

```

```

FUNCTION F2(X1,Y1,X2,Y2)
U=X2-X1
V=Y1**2+Y2**2
IF(ABS(U**2+V).LE.1.0E-7) GO TO 1
GO TO 2
1  F2=0.0
   GO TO 3
2  IF(V.LE.1.0E-7) GO TO 4
   GO TO 5
4  F2=.5*U**2*LOG(U**2)
   GO TO 3
5  F2=.5*(U**2+V)*LOG(U**2+V)+2*U*SQRT(V)*ATAN(U/SQRT(V))
3  F2=F2/4.
   RETURN
END

```

LEGEND FOR ROOM ARRANGEMENT

ASSUME WALL NO. 1 IS ON THE ROOM LENGTH

M OR N

| | | | | |
|---|-----------|-------|----|-------|
| 1 | CEILING | 16.00 | BY | 12.00 |
| 2 | FLOOR | 16.00 | BY | 12.00 |
| 3 | WALL NO.1 | 16.00 | BY | 8.00 |
| 4 | WALL NO.2 | 12.00 | BY | 8.00 |
| 5 | WALL NO.3 | 16.00 | BY | 8.00 |
| 6 | WALL NO.4 | 12.00 | BY | 8.00 |

WINDOWS OR DOORS

| | | A | B | C | D |
|---|------------------|------|------|------|------|
| 7 | WINDOW ON WALL 2 | 4.00 | 2.67 | 6.67 | 2.67 |
| 8 | WINDOW ON WALL 3 | 4.00 | 2.67 | 6.67 | 2.67 |

A - WINDOW HEIGHT

B - WINDOW WIDTH

C - DISTANCE OF LEFT EDGE OF WINDOW TO LEFT WALL

D - HEIGHT FROM FLOOR TO LOWER EDGE OF WINDOW

ARRAY FOR SHAPE FACTORS FROM SURFACE M TO N

| M/N | 1 | 2 | 3 | 4 | 5 | 6 | 7 | 8 |
|-----|--------|--------|--------|--------|--------|--------|--------|--------|
| 1 | .00000 | .36405 | .18326 | .11766 | .16504 | .13472 | .01706 | .01822 |
| 2 | .36405 | .00000 | .18326 | .12078 | .16824 | .13472 | .01394 | .01501 |
| 3 | .27488 | .27488 | .00000 | .12759 | .15887 | .13715 | .00956 | .01706 |
| 4 | .26473 | .27176 | .19139 | .00000 | .16715 | .09464 | .00000 | .01033 |
| 5 | .27006 | .27531 | .17332 | .12157 | .00000 | .14066 | .01909 | .00000 |
| 6 | .26944 | .26944 | .18286 | .08412 | .17192 | .00000 | .01127 | .01095 |
| 7 | .30709 | .25086 | .11468 | .00000 | .21001 | .10144 | .00000 | .01592 |
| 8 | .32793 | .27026 | .20474 | .08261 | .00000 | .09853 | .01592 | .00000 |

An Algorithm for Calculating Radiation Shape Factors Between Attic Surfaces Where the Attic Has a Gabled Room

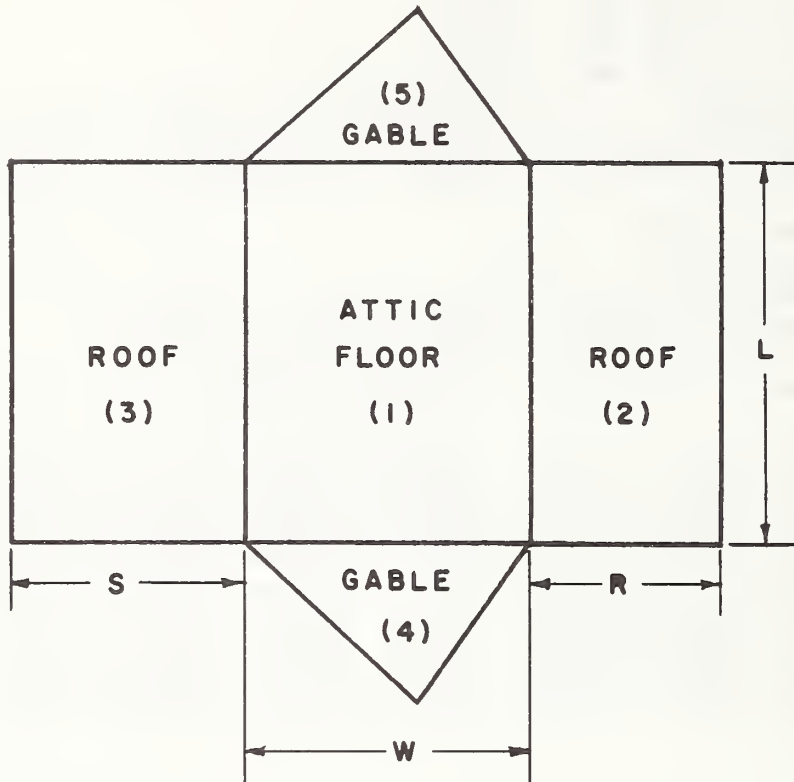

Figure A-13 Definitions of Attic Enclosure

Data:

L = Length of attic floor

W = Width of attic

* This section was contributed by B. A. Peavy and D. M. Burch, Thermal Engineering Systems Section, Center for Building Technology, National Bureau of Standards, Washington, D. C. 20234.

The primary variables determined by this subroutine are:

F_{m-n} = An array giving radiation shape factors between the various inside surfaces of an attic with a gabled roof.

m, n = 1 attic floor (1)

2 roof area (2)

3 roof area (3)

4 front gable (4)

5 rear gable (5)

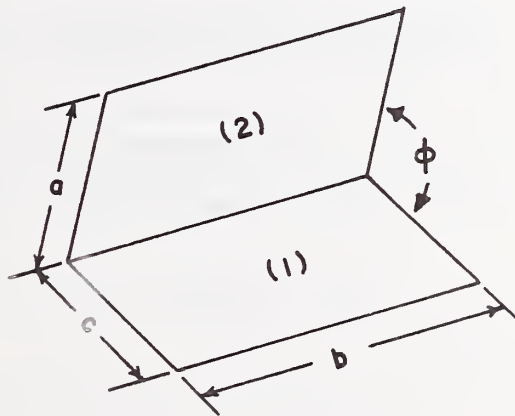

Figure A-14 Radiation Heat Exchange Between Two Adjacent Surfaces

$$X = \frac{a}{b}, Y = \frac{c}{b}, Z^2 = X^2 + Y^2 - 2XY \cos \phi$$

$$\begin{aligned}
\pi Y F_{1-2} = & - \frac{\sin 2\phi}{4} \left\{ XY \sin\phi + \left(\frac{\pi}{2} - \phi \right) (X^2 + Y^2) \right. \\
& + Y^2 \tan^{-1} \left(\frac{X - Y \cos\phi}{Y \sin\phi} \right) + X^2 \tan^{-1} \left(\frac{Y - X \cos\phi}{X \sin\phi} \right) \left. \right\} \\
& + \frac{\sin^2\phi}{4} \left\{ \left(\frac{2}{\sin^2\phi} - 1 \right) \ln \left[\frac{(1 + X^2)(1 + Y^2)}{1 + Z^2} \right] \right. \\
& + Y^2 \ln \left[\frac{Y^2 (1 + Z^2)}{(1 + Y^2) Z^2} \right] + X^2 \cos 2\phi \ln \left[\frac{1 + X^2}{1 + Z^2} \right] + 2X^2 \ln \frac{X}{Z} \left. \right\} \\
& + Y \tan^{-1} \left(\frac{1}{Y} \right) + X \tan^{-1} \left(\frac{1}{X} \right) - Z \tan^{-1} \left(\frac{1}{Z} \right) \\
& + \frac{\sin\phi \sin 2\phi}{2} X \sqrt{1 + X^2 \sin^2\phi} \left\{ \tan^{-1} \left[\frac{Y (1 + X^2 \sin^2\phi)}{1 + X^2 - XY \cos\phi} \right] \right\} \\
& + \cos\phi \int_0^Y \sqrt{1 + \lambda^2 \sin^2\phi} \left\{ \tan^{-1} \left[\frac{X (1 + \lambda^2 \sin^2\phi)}{1 + \lambda^2 - \lambda X \cos\phi} \right] \right\} d\lambda
\end{aligned}
\tag{1}$$

$$\sum_{m=1}^5 F_{n-m} = 1 \tag{2}$$

$$F_{n-m} = \frac{A_m F_{m-n}}{A_n} \tag{3}$$

A_m is area of surface m

Calculation Sequence:

1. $X = R/L, Y = W/L, \phi_1 = \cos^{-1} \left(\frac{W^2 + R^2 - S^2}{2WR} \right)$

Compute F_{1-2}, F_{2-1} [Equations (1) and (3)]

2. If $S = R, \phi_2 = \phi_1, F_{1-3} = F_{1-2}, F_{3-1} = F_{2-1}$, skip stage 3

3. $X = S/L, Y = W/L, \phi_2 = \cos^{-1} \left(\frac{W^2 + S^2 - R^2}{2WS} \right)$

Compute F_{1-3}, F_{3-1} [Equations (1) and (3)]

4. $X = S/L, Y = R/L, \phi_3 = \pi - \phi_1 - \phi_2$

Compute F_{2-3}, F_{3-2} [Equations (1) and (3)]

5. $F_{m-4}, F_{m-5}, m = 1, 2, 3$ [Equation (2)]

6. $F_{4-m}, F_{5-m}, m = 1, 2, 3$ [Equation (3)]

7. F_{4-5}, F_{5-4} [Equation (2)]

FI

An Algorithm for Approximating Inside Surface Heat Transfer
Coefficients Tabulated in Table 1, Page 357 of the 1972
ASHRAE Handbook of Fundamentals

Data:

IDIR: Heat flow direction index

- | | | |
|--------|---|--------------|
| | 1 | Upward |
| | 2 | 45° upward |
| IDIR = | 3 | Horizontal |
| | 4 | 45° downward |
| | 5 | Downward |

ϵ : Emittance of the surface

IV: Moving air index (IV = 0 corresponds to still air)

Calculation Sequence:

1. If IV = 0, $FI = h_c + 1.02 * \epsilon$

where

| | | |
|---------|------|--------------|
| | .712 | 1 |
| | .682 | 2 |
| $h_c =$ | .542 | for IDIR = 3 |
| | .402 | 4 |
| | .162 | 5 |

2. If IV \neq 0, $FI = 2.0$ Btu per (hr) (sq ft) (F)

FO

An Algorithm for Determining Outside Surface Heat Transfer
Coefficient As a Function of Air Velocity and the Type
of Surface Constructions

Data:

V: Wind velocity, knots (Determined in CLIMATE)

DIR: Wind direction (Determined in CLIMATE)

IS: Outside surface index

| | | |
|------|---|----------------------------|
| IS = | 1 | Stucco |
| | 2 | Brick and rough plaster |
| | 3 | Concrete |
| | 4 | Clear pine |
| | 5 | Smooth plaster |
| | 6 | Glass, white paint on pine |

WA: Wall azimuth angle, degree

Calculation Sequence:

1. Conversion of the unit of wind velocity from knots into mph.

$$V' = 1.153 * V$$

2. Outside surface heat transfer coefficient.

$$FO = A * (V'^{**2}) + B * V' + C$$

where A, B and C are given in Table A-8

Table A-8

Value of Coefficients For Calculation
of Outside Heat Transfer Coefficient

| IS | A | B | C |
|----|----------|-------|------|
| 1 | 0.0 | 0.464 | 2.04 |
| 2 | 0.001 | 0.320 | 2.20 |
| 3 | 0.0 | 0.330 | 1.90 |
| 4 | -0.002 | 0.315 | 1.45 |
| 5 | 0.0 | 0.244 | 1.80 |
| 6 | -0.00125 | 0.262 | 1.45 |

3. Relative wind direction to the wall surface.

$$RWD = WA + 180 - DIR$$

$$\text{If } |RWD| > 180, RWD = 360 - RWD$$

4. Conversion of the unit of wind velocity into m per sec.

$$VV = 0.51479 * V$$

5. Air velocity close to wall surface

$$\text{If } |RWD| < 90 \text{ (windward)}$$

$$VC = 0.25 * VV \quad \text{for } VV > 2$$

$$VC = 0.5 \quad \text{for } VV \leq 2$$

$$\text{If } |RWD| \geq 90 \text{ (leeward)}$$

$$VC = 0.3 + 0.05 * VV$$

6. Convection component of the outside surface heat transfer coefficient.

$$FOC = 3.28 * ((VC)**0.605)*$$

* This equation was derived by K. Kimura based upon the recent data published in Reference 6.

ACR*

An Algorithm for Determining Thermal Resistance
Across the Air Cavity in Walls and Roofs

Data:

DT: Temperature difference across the air space, F

L: Thickness of the air space, in.

IDIR: Heat flow direction index

1 upward

2 45° upward

IDIR = 3 horizontal

4 45° downward

5 downward

ϵ_1, ϵ_2 : Emittance of the surfaces facing the air cavity

ATC: Average temperature of the air cavity, F

Calculation Sequence:

1. Let $x = \text{Log} (DT * (L ** 3))$

Then using the values for $A_0, A_1, A_2, A_3,$ and A_4 which are given in Table A-9, calculate

$$y = A_0 + A_1 * x + A_2 * (x ** 2) + A_3 * (x ** 3) + A_4 * (x ** 4)^{*/}$$

* This polynomial has been derived to represent experimental data presented in Figure 6 of reference 7 and shown here in Figure A-15.

Table A-9 VALUES OF A_0 , A_1 , A_2 , A_3 , and A_4 FOR CALCULATION OF RESISTANCE ACROSS THE AIR SPACE

| IDIR | Range of $DT*(L^{**3})$ | A_0 | A_1 | A_2 | A_3 | A_4 |
|------|------------------------------|---------|---------|---------|---------|---------|
| 11 | All the range | -1.5904 | 0.2824 | 0.0 | 0.0 | 0.0 |
| 22 | $1 < DT*(L^{**3}) \leq 10$ | -1.7125 | -0.0875 | 0.2437 | -0.0420 | 0.0 |
| | $10 < DT*(L^{**3}) \leq 100$ | -1.8546 | 0.3124 | 0.0 | 0.0 | 0.0 |
| | $100 < DT*(L^{**3})$ | -1.7380 | 0.2910 | 0.0 | 0.0 | 0.0 |
| 3 | $1 < DT*(L^{**3}) \leq 10$ | -1.7410 | -0.0331 | 0.0198 | -0.0146 | 0.0 |
| | $10 < DT*(L^{**3}) \leq 100$ | 1.0460 | -3.4660 | 1.5482 | -0.2669 | 0.01673 |
| | $100 < DT*(L^{**3})$ | -0.2141 | -0.6577 | 0.1693 | -0.0095 | 0.0 |
| 4 | $1 < DT*(L^{**3}) \leq 10$ | -1.7420 | 0.0163 | -0.0409 | 0.0204 | 0.0 |
| | $10 < DT*(L^{**3}) \leq 100$ | -6.5410 | 5.5710 | -2.3690 | 0.4467 | -0.0300 |
| | $100 < DT*(L^{**3})$ | -0.1914 | 6.1610 | -1.3390 | 0.1339 | -0.0050 |
| 5 | $1 < DT*(L^{**3}) \leq 10$ | -1.770 | 0.0 | 0.0 | 0.0 | 0.0 |
| | $10 < DT*(L^{**3})$ | -1.745 | 0.0028 | 0.0029 | 0.0008 | 0.0 |

2. Let $z = \text{Exp}(y)$

$$\text{If } z > 0.3 \quad h_c = z * (1 - 0.001 * (DT-50))/L$$

$$\text{If } 0.2 \leq z \leq 0.3 \quad h_c = z * (1 + 0.00035 * (DT-50))/L$$

$$\text{If } z < 0.2 \quad h_c = z * (1 + 0.0017 * (DT-50))/L$$

$$3. h_r = 0.00686 * (((ATC + 460)/100) ** 3)^{**}/$$

$$4. RES = 1/(h_c + (1/(1/\epsilon_1 + 1/\epsilon_2 - 1)) * h_r)$$

^{**/} This polynomial has been derived to represent the curve presented in Figure 5 of reference 7 and shown here in Figure A-16.

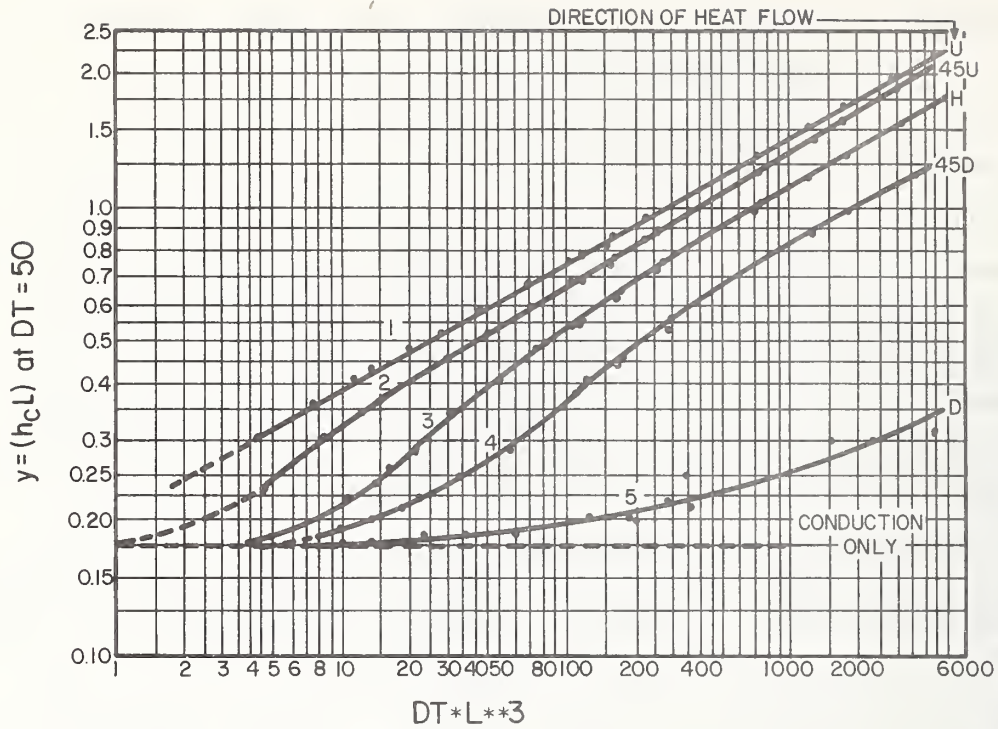

Figure A-15 Convection-Conduction Coefficient for Heat Transfer Across an Air Space for Five Orientations of the Air Space and Directions of Heat Flow

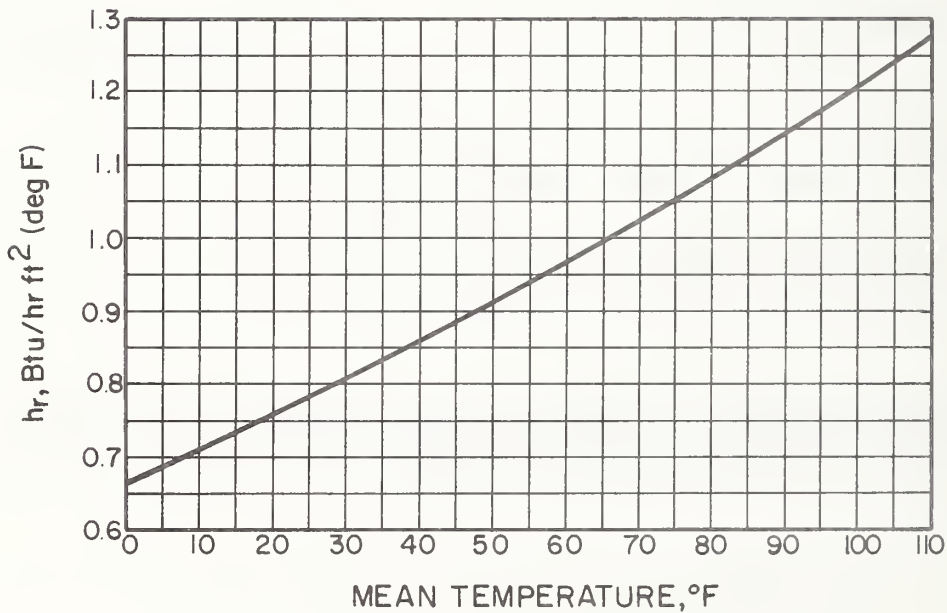

Figure A-16 Linear Radiation Coefficient for Heat Transfer Across an Air Space for a Radiation Interchange Factor

A Description of the Calculation Procedure for Transient
Heat Conduction Using Conduction Transfer Functions

Conduction transfer functions are used widely and considered as a convenient and effective tool for the evaluation of transient heat transfer in building construction components. The conventional steady state heat transfer equation for calculating heat loss:

$$Q = U * (T_a - T_o) \quad (1)$$

where U: overall heat transfer coefficient of roof or wall

T_a: inside air temperature

T_o: outside air temperature

is not sufficient for evaluating transient heat transfer. This equation becomes invalid because the outdoor temperature T_o usually varies as affected by solar radiation, cloud cover and wind effect. The effect of the rapid change of the outdoor temperature will not be accounted for unless the structure is extremely lightweight, such as galvanized steel.

Approximate calculation for a more accurate determination of the instantaneous heat transfer can be made by replacing T_a - T_o of equation (1) by a Total Equivalent Temperature Difference (TETD) which is usually precalculated for typical building construction components and takes into account the thermal storage effect. Although very useful, the TETD concept is only valid when the outside temperature T_o undergoes steady periodic changes. The TETD concept is therefore especially useful computing design heat transfer rates for the building where very warm or very cold

conditions are assumed to occur for several successive days.

A more accurate formulation for conduction heat transfer from a room to randomly fluctuating outdoor conditions is to use the hourly history of temperatures in conjunction with Conduction Transfer Functions (CTF). For example, in calculating the energy transfer from a room at an inside surface, the equation would be:

$$Q_{i,t} = \sum_{j=0}^N X_j * T_{a,t-j} - \sum_{j=0}^N Y_j * T_{o,t-j} + R * Q_{t-1} \quad (2)$$

where X_j , Y_j (for $j = 0, 1, 2 \dots N$), and R are the Conduction Transfer Functions. In equation (2), $T_{o,t-j}$ and $T_{a,t-j}$ represent outdoor and room air temperatures respectively at j th hour prior to the time for which the value of Q_t is needed. And Q_{t-1} is the heat loss Q_t , from the room at the previous hour. By having a record of $T_{o,t-1}$, $T_{o,t-2}$, $T_{o,t-3} \dots T_{o,t-j}$; and $T_{a,t-1}$, $T_{a,t-2} \dots T_{a,t-j}$; it is possible to determine the instantaneous conduction transfer, provided that the values for X_j and Y_j , and R are available.

The number of terms involved for the calculation of Q_t (or the value of N in equation (2)) depends upon the type of roof or wall construction. Generally heavy constructions require a large value, although for most conventional constructions, it seldom exceeds 20. Stephenson and Mitalas^{8/} have shown that the value of N can be further decreased by employing more than one past record of Q_t (or Q_{t-j} with j being more than 1) in the following manner:

$$Q_{i,t} = \sum_{j=0}^{N'} A_j * T_{a,t-j} - \sum_{j=0}^{N'} B_j * T_{o,t-j} - \sum_{j=1}^N D_j * Q_{i,t-j} \quad (3)$$

where A_j , B_j , and D_j are the Modified Conduction Transfer Functions according to Stephenson and Mitalas^{8/}. Table A-10 gives values of Conduction Transfer Functions calculated for a brick wall having an overall heat transfer coefficient of 0.418. In this table, the factors designated by Z_j and C_j are the additional transfer function to be used for evaluating the instantaneous heat loss $Q_{o,t}$ at the exterior side of the structure. The applicable equations for this side of the structure are then:

$$Q_{o,t} = \sum_{j=0}^N Y_j * T_{a,t-j} - \sum_{j=0}^N Z_j * T_{o,t-j} + R * Q_{o,t-1} \quad (4)$$

or

$$Q_{o,t} = \sum_{j=0}^{N'} B_j * T_{a,t-j} - \sum_{j=0}^{N'} C_j * T_{o,t-j} - \sum_{j=1}^{N'} D_j * Q_{o,t-j} \quad (5)$$

The table also shows that for the calculation of $Q_{o,t}$ the use of Stephenson type transfer functions would permit the reduction of N from 10 to $N' = 4$ with a corresponding increase of three terms in the past record of $Q_{o,t}$.

Table A-10

| Construction Data | Thickness (f) | Thermal Conductivity Btuh/ft | Density lb/ft ³ | Specific Heat Btu/lb °F | Thermal Resistance sq ft hr F/Btu |
|---|------------------|------------------------------------|-------------------------------|-------------------------------|--|
| Inside Surface | 0.000 | -- | -- | -- | .830 |
| 4-in com- mon brick | 0.333 | .420 | 100.42 | .220 | .793 |
| 4-in face brick | 0.333 | .770 | 125.00 | .220 | 0.432 |
| Outside surface | 0.000 | -- | -- | -- | .330 |
| | | | | | 2.385 |
| Time increment: 1 hour | | | | | |
| Overall heat transfer coefficient U = 0.418 | | | | | |

Conduction Transfer Functions (CTF)

| j | X _j | Y _j | Z _j | R |
|----|----------------|----------------|----------------|--------|
| 0 | .9194 | .0001 | 1.9833 | 0.8398 |
| 1 | -.9391 | .0080 | -2.1785 | |
| 2 | .0606 | .0243 | .1983 | |
| 3 | .0153 | .0186 | .0387 | |
| 4 | .0061 | .0090 | .0144 | |
| 5 | .0026 | .0039 | .0060 | |
| 6 | .0011 | .0017 | .0026 | |
| 7 | .0005 | .0007 | .0011 | |
| 8 | .0002 | .0003 | .0005 | |
| 9 | .0001 | .0001 | .0002 | |
| 10 | .0000 | .0001 | .0001 | |

Stephenson Type Transfer Functions

| j | A _j | B _j | C _j | D _j |
|---|----------------|----------------|----------------|----------------|
| 0 | 0.9194 | 0.0001 | 1.9833 | 1.000 |
| 1 | -1.4128 | 0.0079 | -3.2002 | -1.3552 |
| 2 | 0.5785 | 0.0202 | 1.3942 | 0.4699 |
| 3 | -0.0511 | 0.0064 | -0.1448 | 0.0315 |
| 4 | 0.0007 | 0.0002 | 0.0024 | 0.0002 |

Data:

- NL: Number of layers to be considered for the analysis of a given structure: the number of layers should include surface resistance or air cavity resistance if they contribute significantly to the overall heat transfer of that particular structure
- K_i : Thermal conductivity of i-th layer in Btu per (hr) (ft) (F). This value is not needed for air cavities or for the surface resistance layers.
- ρ_i : Density of i-th layer in lb per (cu. ft). This value is not needed for air cavities or for the surface resistance layers
- C_i : Specific heat of i-th layer material in Btu per (lb) (F). This value is not needed for air cavities or for the surface resistance layers.
- L_i : Thickness of the i-th layer in ft. This value is not needed for the air cavities or for the surface resistance layers.
- RES_i: Thermal resistance of air cavities and surface resistance layers in (hr) (sq ft) (F) per Btu. This value is not needed whenever all of the remaining values such as K_i , ρ_i , C_i and L_i are given.

DT: Time increment for the conduction transfer functions in hr (usually one hour for the building heat transfer calculations).

Subscript i refers to i -th layer and it varies from 1 to NL.

The sequence of inputting the above property values for each layer is very important and must be consistent with the particular convention adopted for the specific calculation routine. The sequence must follow in order from the inside layer to the outside layer or vice versa. It should be noted that the inclusion of the surface thermal resistance as independent layers is optional depending upon the end use of the conduction transfer functions. If the inside surface temperature is to be computed as a balance of all the heat flow involved at that surface, the thermal resistance of the inside surface should not be included in the calculation of the conduction transfer functions. The same comment applies for the outside surface.

An algorithm for the calculation of the conduction heat transfer functions will not be given here, since it involves lengthy mathematical solutions to the standard transient heat conduction differential equation. Reference (9) provides an excellent background for this calculation. Several computer programs^{10, 11/} are available for the calculation of conduction transfer functions for multi-layer walls, roofs and floor constructions. The program developed by the National Research Council of Canada^{10/} requires the layer input to be placed in order from outside toward inside. It calculates the Stephenson type conduction transfer

functions directly. The program of the National Bureau of Standards^{11/} requires the input to be placed from the inside layer first and calculates the conduction transfer functions of plane, cylindrical and spherical walls. It also calculates the transfer functions for solid objects of plane, cylindrical and spherical shapes as well as the heat conduction systems involving semi-infinite solids, approximated by basement floors and underground constructions.

Under non-steady heat conduction, the heat lost from one side of a surface is not equal to the rate of heat entry at another side. Equations (2) and (3), however, must be valid also for the steady state heat transfer problems. One of the best ways to check the consistency of the conduction transfer functions is to use them in the solution of steady state problems and see if the following criteria is met: The room side surface temperature and the outdoor side surface temperature are maintained constant for many hours so that

$$TOS_t = TOS_{t-1} = \dots\dots TOS_{t-N}$$

$$TIS_t = TIS_{t-1} = \dots\dots TIS_{t-N}$$

$$QI_t = QO_t = QO_{t-1} = QI_{t-1}$$

Thus

$$QO_t = TIS_t * \sum_{j=1}^N Y_j - TOS_t * \sum_{j=1}^N Z_j + R * QO_t$$

$$QI_t = TIS_t * \sum_{j=1}^N X_j - TOS_t * \sum_{j=1}^N Y_j + R * QI_t$$

In order to satisfy these two equations simultaneously, it is necessary that

$$\sum_{j=1}^N X_j = \sum_{j=1}^N Y_j = \sum_{j=1}^N Z_j = U*(1 - R)$$

In fact, the conduction transfer functions of the sample wall shown in Table A-10 can be shown to satisfy this requirement

$$\sum X_j = \sum Y_j = \sum Z_j = 0.0668$$

and

$$U*(1 - R) = 0.418*(1 - 0.8398) = 0.0669$$

HEATW

An Algorithm for Calculating Transient Heat Conduction Through Opaque Walls or Roofs Using Conduction Transfer Functions

Data:

X_j , Y_j and Z_j for $j = 0, 1, 2, \dots, N$: Conduction transfer functions in Btu per (hr) (sq ft), (Calculated as outlined in XYZ for the system that excludes the inside and outside heat resistance layers)

R: Common ratio of the conduction transfer function (Calculated as outlined in XYZ),

$$R = \frac{X_{j+1}}{X_j} = \frac{Y_{j+1}}{Y_j} = \frac{Z_{j+1}}{Z_j} \text{ for } j \geq N$$

N: Number of the significant terms to be used for the conduction heat transfer calculation, (Calculated as outlined in XYZ)

FO_t : Outside surface heat transfer coefficient at time t , Btu per (hr) (sq ft) (F)

IT_t : Total solar radiation intensity on the outside surface at time t , Btu per (hr) (sq ft), (Calculated in SOLAD)

TIS_{t-j} : History of inside surface temperature at times $t-1, t-2, \dots$ and $(t-N)$ th hour, F

TOS_{t-j} : History of outside surface temperature at times $t-1, t-2, t-3, \dots$ and $(t-N)$ th hour, F

DB_t : Outdoor air dry-bulb temperature at time t , F

HEAT_{t-1}: Heat loss at the interior surface to the outdoor environment at the previous hour, Btu per (hr) (sq ft)

QO_{t-1}: Heat loss at the exterior surface to the outdoor environment at the previous hour, Btu per (hr) (sq ft)

a: Solar absorption coefficient at the exterior surface

α : Cosine of the angle subtended by a vertical line and the surface normal ... (Calculated in SUN)

TC_t: Total cloud amount ... (Calculated in CLIMATE)

TM: A reference temperature (usually the inside design temperature), F

Calculation Sequence:

A. Exterior walls and roof

1. The heat balance equation at the exterior surface is given by

$$QR_t + QA_t + QO_t - QS_t = 0$$

where

a) Incident solar radiation

$$QR_t = a * IT_t$$

b) Convection heat transfer from the outdoor air

$$QA_t = FO_t * (DB_t - TOS_t)$$

c) Conduction heat flow from the inside surface

$$QO_t = \sum_{j=0}^N Y_j * (TIS_{t-j} - TM) - \sum_{j=0}^N Z_j * (TOS_{t-j} - TM) + R * QO_{t-1}$$

d) Heat loss to the sky

$$QS_t = 2 * \alpha * (10 - TC_t)^{**}$$

2. Let

$$SUM1 = \sum_{j=0}^N Y_j * (TIS_{t-j} - TM) + CR * QO_{t-1}$$

$$SUM2 = \sum_{j=1}^N Z_j * (TOS_{t-j} - TM)$$

3. Outside surface temperature

$$TOS_t = (QR_t - QS_t + FO_t * DB_t + SUM1 - SUM2 + Z_0 * TM) / (FO_t + Z_0)$$

4. Using this new TOS_t , the heat loss at the interior surface is

then determined as follows:

$$HEAT_t = \sum_{j=0}^N X_j * (TIS_{t-j} - TM) - \sum_{j=0}^N Y_j * (TOS_{t-j} - TM) + R * HEAT_{t-1}$$

* Throughout this discussion a value of TM is always subtracted from the interior surface and exterior surface temperatures. This subtraction usually helps to minimize the digital errors which occur and are sometimes significant when a large number of numerical data are multiplied and added. Since $\sum_{j=0}^N X_j = \sum_{j=0}^N Y_j$, the net effect of the subtraction is zero.

** This expression was developed to yield a roof sky radiation of 20 Btu per (hr) (sq ft) for a cloudless condition, which was reported in reference (12).

INSULATED ROOF (SUMMER)

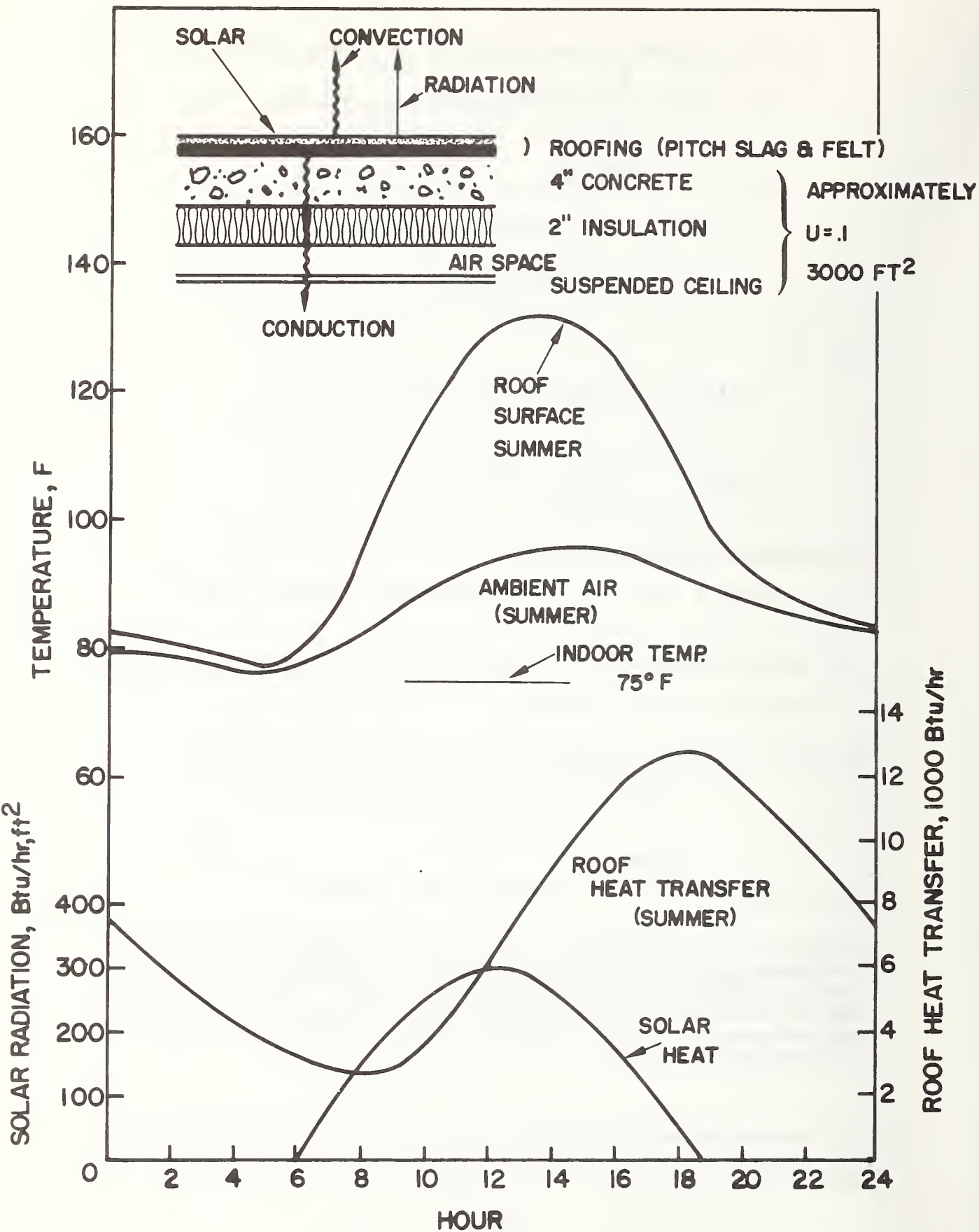

Figure A-17 Transient Heat Transfer in a Typical Roof

Table A-11

| Layer No. | L(I) | K(I) | ρ (I) | C(I) | RES(I) | Description of Layers |
|-----------|------|-------|------------|------|--------|-----------------------|
| 1 | 0. | 0. | 0. | 0. | 2.04 | Suspended Ceiling |
| 2 | .167 | .025 | 13. | .320 | 0. | 2-in. Insulation |
| 3 | .333 | 1.000 | 140. | .200 | 0. | 4-in. Concrete |
| 4 | .031 | .110 | 70. | .400 | 0. | 3/4-in. Felt |
| 5 | .042 | .830 | 55. | .400 | 0. | 1/2-in. Pitch Slag |

Time Increment DT = 1.

Conduction Transfer Functions

| j | X_j | Y_j | Z_j | R |
|---|---------|--------|----------|--------|
| 0 | .21934 | .00011 | 3.30513 | .78793 |
| 1 | -.25485 | .00504 | -4.27082 | |
| 2 | .04650 | .01060 | .97885 | |
| 3 | .00857 | .00493 | .00808 | |
| 4 | .00224 | .00140 | .00104 | |
| 5 | .00059 | .00037 | .00024 | |
| 6 | .00016 | .00010 | .00006 | |
| 7 | .00004 | .00003 | .00002 | |
| 8 | .00001 | .00001 | .00000 | |
| 9 | .00000 | .00000 | .00000 | |

Figure A-17 shows the energy balance that is involved in the above calculation sequence and the results of a typical calculation. Table A-11 gives the conduction transfer functions for the roof used in the calculations.

B. Interior walls and floor/ceiling sandwich

The calculation sequence for the partition wall and floor/ceiling sandwich is completely different from that of the exterior wall or roof. The difference is due to the fact that the air temperature at the exterior side of the construction can be assumed the same as at the interior side, at least for a climate controlled building. In order to take advantage of this fact, conduction transfer functions should be determined with the surface thermal resistance layer added at the exterior side of the structure. The heat loss through a partition wall is then calculated by

$$\text{HEAT}_t = \sum_{j=0}^N X_j * (T_{I,t-j} - T_M) - \sum_{j=0}^N Y_j * (T_{A,t-j} - T_M) + R * \text{HEAT}_{t-1}$$

where $T_{A,t-j}$ = room temperature at time (t-j)th hour

If the room temperature were maintained constant at T_M , which is usually the case, the terms involving the Y_j 's would then drop out of the equation.

C. Slab on grade floor

The heat loss to the ground through the floor on grade can be calculated by using conduction transfer functions determined on the basis of flooring, concrete, and 12 inches of ground layer

$$\text{HEAT}_t = \sum_{j=0}^N X_j * (\text{TI}_{t-j} - \text{TM}) - \sum_{j=0}^N Y_j * (\text{TG} - \text{TM}) + R * \text{HEAT}_{t-1}$$

Since usually TG is constant and

$$\sum_{j=0}^N Y_j = U_G * (1 - R),$$

then

$$\text{HEAT}_t = \sum_{j=0}^N X_j * (\text{TI}_{t-j} - \text{TM}) - U_G * (1 - R) * (\text{TG} - \text{TM}) + R * \text{HEAT}_{t-1}$$

The same method is applicable to a floor with a crawl space as long as the space is not vented. The conduction transfer functions for the floor with an unvented crawl space simply has an additional air resistance layer to account for the dead air space between the floor and the ground. In many cases it is safe to assume that TG = TM, and then the term involving U_G would drop out of the equation.

D. Floor over the vented crawl space

The floor over a vented crawl space can be treated in the same manner as an exterior wall or roof except that the solar radiation and sky radiation terms would not be included in the energy balance and that the outside surface heat transfer coefficient is replaced by a value similar in magnitude to the inside surface heat transfer coefficient. If the conduction transfer functions include the outside surface heat transfer resistance, the calculation is simply

$$\text{HEAT}_t = \sum_{j=0}^N X_j * (\text{TI}_{t-j} - \text{TM}) - \sum_{j=0}^N Y_j * (\text{DB}_{t-j} - \text{TM}) + R * \text{HEAT}_{t-1}$$

SCHEDULE

An Algorithm to Determine Heat Gains From Lighting,
Equipment, Occupancy and Ventilation

Data:

1. Normalized 24 hour profiles ($j = 1, 2, 3 \dots 24$) of operational schedules for weekdays ($i = 1$) and weekends and holidays ($i = 2$) are given for lighting, equipment use, occupancy, ventilation, indoor temperature setting, and humidity setting as follows:

QLITE _{i,j} : Lighting schedules (fraction of some maximum)

QEQUP _{i,j} : Equipment use schedules (fraction of some maximum)

QOCUP _{i,j} : Occupancy schedule (fraction of some maximum)

QVENT _{i,j} : Ventilation fan operating schedule (fraction of some maximum)

ROOMDB _{i,j} : Space thermostat setting schedule

ROOMRH _{i,j} : Space humidistat setting schedule

2. Maximum values of the parameters to be used with the schedules

QLITX: Maximum electric power demand for lighting
for the 24 hour period

QEQUPX: Maximum electric power demand for appliances
for the 24 hour period, KW

QOCUPX: Maximum number of equivalent sedentary adult occupants during the 24 hour period

QVENTX: Maximum amount of ventilation air supply during the 24 hour period, cu. ft per min.

QHTWIX: Maximum amount of hot water demand during the 24 hour period, gallons per hour

3. YEAR, MONTH AND DAY

These data are needed to determine whether the day is a weekday, weekend, or holiday, and whether the day falls within daylight savings time.

4. QOS(TA): Sensible heat loss of a sedentary adult at the room temperature TA, Btu per (hr) (occupant)

QOL(TA): Latent heat loss of a sedentary adult at the room temperature TA, Btu per (hr) (occupant)

WO(DB,WB): Humidity ratio of the outdoor air for a given outdoor air dry-bulb and wet-bulb temperature, lb of water vapor per (lb of dry air)

WI(TA,WGA): Humidity ratio of the indoor air for a given dry-bulb temperature and wet-bulb temperature, lb of water vapor per (lb of dry air)

QWT: Heat needed to generate one gallon of hot water, Btu per gallon of water

Calculation Sequence:

1. Determine the weekday indicator IWK from WKDAY
2. Determine the holiday indicator IHOL from HOLIDAY
3. If IWK = 1 or 7 i = 2
 If IHOL = 1 i = 2
 Otherwise i = 1

4. Heat generated from lights (for j = 1 ... 24), Btu per hr

$$QS_{i,j} = QLITX * 34.13 * QLITE_{i,j}$$

5. Heat generated from equipment and occupants, Btu per hr
(for j = 1, 2 ... 24)

Sensible heat

$$QS'_{i,j} = QEQUX * 34.13 * QEQUP_{i,j} + QOCUPX * QOS(TA) * QOCUP_{i,j}$$

Latent heat

$$QL_{i,j} = QOCUPX * QOL(TA) * QOCUP_{i,j}^*$$

6. Heat gain due to ventilation air, Btu per hr

Sensible heat

$$LEAK_{i,j} = QVENTX * C_p * 60 * (DB_j - ROOMDB_{i,j}) * QVENT_{i,j} * \rho$$

Latent heat

Determine WI_j from PSY using $ROOMDB_{i,j}$ and $ROOMRH_{i,j}$

$$LEAK'_{i,j} = QVENTX * 60 * (WO_j - WI_j) * 1060 * QVENT_{i,j} * \rho$$

C_p and ρ on this page depict specific heat and density of air in the English units.

* It has been assumed that there is no latent portion of the equipment heat gain. There can be exceptions to this.

Fundamentals of Room Temperature and Cooling
(Heating) Load Calculations

The basic energy transfer process that occurs in a room can best be illustrated by an electrical circuit network as shown in Figure A-18. The figure represents the phenomenon in a typical room having two exterior walls, each of which contains a window, and two interior partition walls, in addition to the roof and floor (see Figure A-19). Heat conduction paths through the walls, roof, and floor are depicted by resistance and capacitance circuits and these through windows are represented by resistance circuits, implying that the windows do not have significant thermal mass. Points T_{S1} through T_{S8} in Figure A-18 indicate interior surfaces of the walls, roof, floor and windows, all of which receive conduction heat through solid material, solar radiation (represented by $\leftarrow q$) through transparent surface and long wavelength radiation from other solid surfaces indicated by solid lines connecting the surface nodes; and they lose heat to the room air (represented by a point called TA) by the convection process (dashed lines).

At the top of Figure A-18, the radiation heat exchange between the room surfaces, the surfaces of lighting fixtures, equipment such as business machines, and occupants is depicted. Also indicated in this same location is the convective heat exchange between these items and the room air. Actual heat or power input to these internal heat sources are indicated by $\leftarrow Q$. Although not indicated in this figure, it is possible to represent the conduction heat gain from the inner core of lighting fixtures and equipment if they have sufficient thermal mass. This equipment could of course include the unit heaters or air conditioners

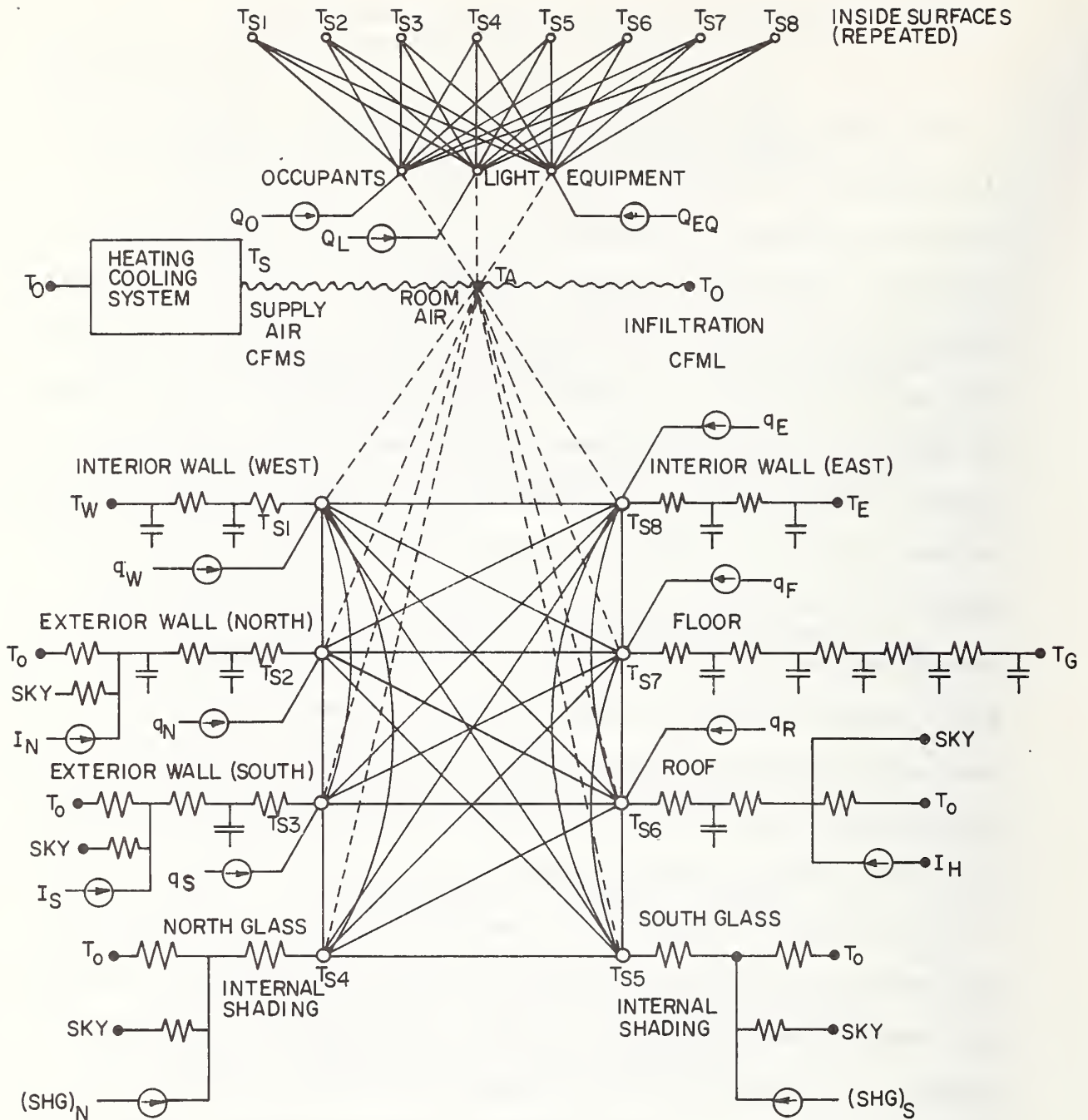

- THERMAL RESISTANCE
- THERMAL CAPACITENCE
- THERMAL CURRENT SOURCE

Figure A-18 Analogous Electric Circuit for Heat Exchange Process in a Room

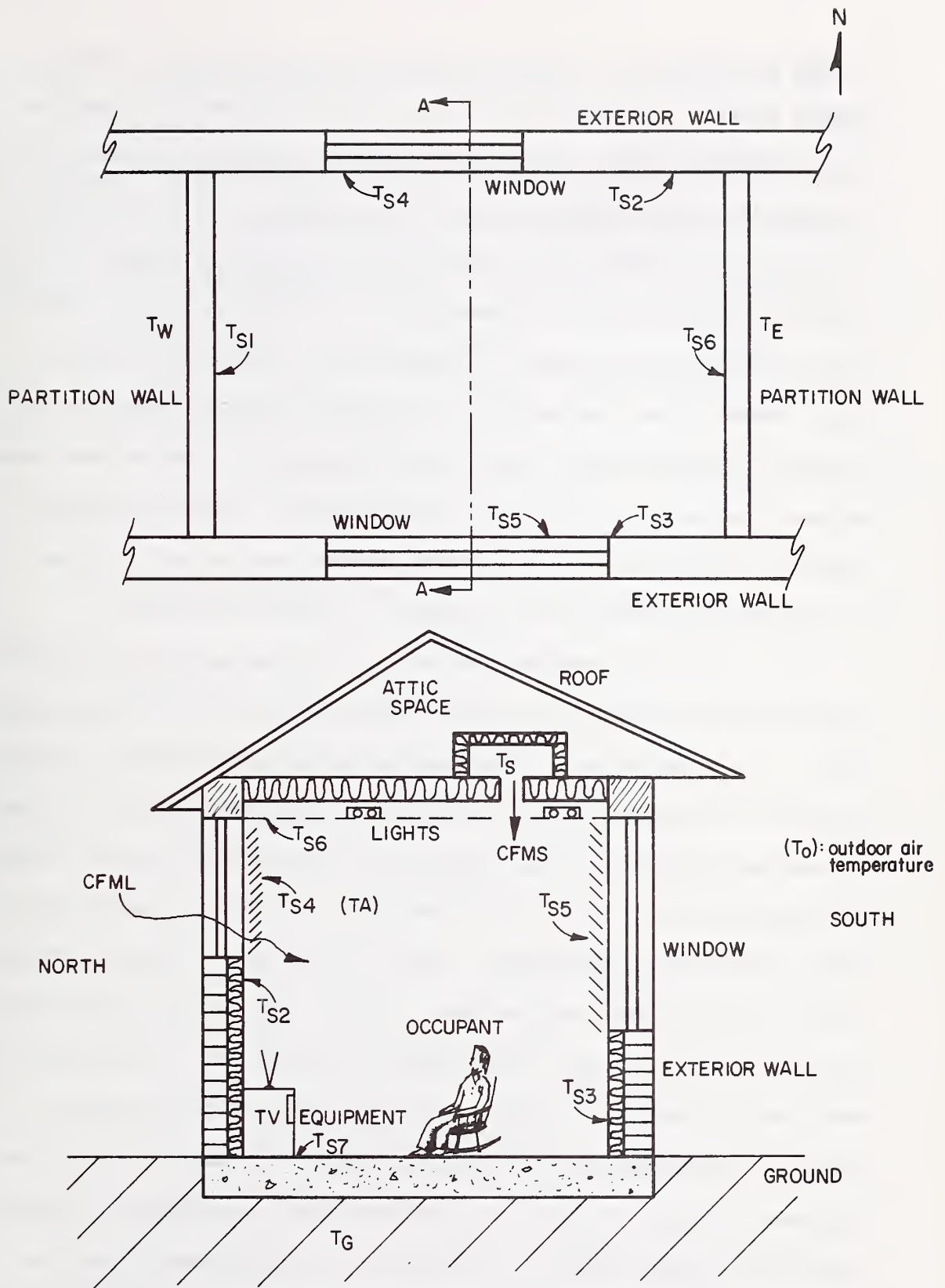

Figure A-19 Physical Model of a Typical Room Used in Figure A-18

if they are the part of the room heat exchange system. The room air changes energy with outdoor air or with the conditioned air from the central climate control system (or the forced ventilation system) and is depicted in this figure by lines $\overline{T_s T_a}$ and $\overline{T_o T_a}$. The heat exchange at the exterior surfaces with outdoor air, sky and sun (except for the partition walls and floor on grade) are also indicated using a normal design calculation procedure, the temperature or heat flow at the exterior sides of the room surfaces are usually available either by calculation or as input data. The exception occurs when two or more rooms adjacent one another are treated simultaneously. This latter case is commonly referred to as a "multi-room problem" and is very complex. No satisfactory solution for this case is presently available.

This electrical network problem can be solved and the corresponding calculation algorithm is called RMTMP (given in the following section). The solution can be obtained in two different modes: room temperature calculation mode or the room load calculation mode. The room temperature calculation mode requires the simultaneous solution of heat balance equations in order to determine all the surface temperatures together with the air temperature. On the other hand, the room cooling load calculation mode requires that the room temperature be prescribed and only the room surface temperatures are solved for. The convective heat exchange between the room air and the heat emitting surfaces is then the cooling load (or the heating load if the heat is lost to the surfaces). These two modes of computation can be combined to simulate the actual thermal behavior of a room and its environment where the temperature fluctuates. The floating temperature would be calculated

as long as it remained between prescribed limits. A heating load would be computed when the room temperature fell to the lower limit and a cooling load would be calculated when the temperature rose to the upper limit. In this manner, the calculation of load and subsequent energy requirement would more closely correspond to actual building and system operation.

RMTMP

An Algorithm to Calculate Thermal Load or Room Temperature

This routine calculates heating and cooling loads or room temperature by solving heat balance equations involving each of the room surfaces. A room surface receives conduction heat flow through the solid wall, roof or floor material from behind, convection heat flow from the air and radiation heat flow from other surfaces and internal heat sources such as occupants, equipment and lighting fixtures.

Data:

NS: Total number of heat transfer surfaces contributing to the room heat balance

S_i : Area of i -th heat transfer surface, sq. ft., where
 $i = 1, 2, 3, \dots NS$

$X_{i,j}$, $Y_{i,j}$ and $Z_{i,j}$:
Where $i = 1, 2, 3, \dots NS$
 $j = 1, 2, \dots N_i$

Conduction transfer functions of i -th surface in Btu per (hr) (sq. ft.) ... (Calculated in XYZ). These conduction transfer functions are usually evaluated without the interior or room side surface thermal resistance. The thermal resistance layer of exterior surface is also omitted if the exterior surface temperature is to be computed as a result of a heat balance involving solar radia-

tion, sky radiation and convective loss to the outdoor air.

N_i : Number of conduction transfer function terms to be used for the calculation of the i -th surface conduction heat gain

R_i : Common ratio for the conduction transfer function of the i -th surface

$TOS_{i,t-j}^*$: for $i = 1, 2, 3, \dots NS$ and $j = 0, 1, 2, \dots N_i$
Outside surface temperature history from present hour to that of N_i hours ago for i -th surface, F.
(This information is available from HEATW routine.)

$TIS_{i,t-j}$: for $i = 1, 2, 3, \dots NS$ and $j = 1, 2, 3, \dots N_i$
Inside surface temperature history from one hour ago to N_i hours ago for i -th surface, F. The present value (for $j = 0$) will be computed in this routine and stored for future use.

TA_t : Air temperature of the room at time t , F

DB_t : Outdoor air temperature at time t , F

TS_t : Supply air temperature from the central system at time t , F

H_i : Inside surface convection heat transfer coefficient for i -th surface, Btu per (hr) (sq. ft.)
(F)

* Subscript t refers to the present time t and $t-j$ refers to the present time minus j hours.

- $F_{i,k}$: Radiation heat exchange view factor between the i-th surface and k-th surface
- $$F_{i,i} = F_{k,k} = 0$$
- E_i : Emissivity of the i-th surface
- $R_{i,t}$: Radiant heat flux impinging upon i-th surface at time t from various sources, which include solar radiation, radiation from lights, occupants and equipment, Btu per (hr) (sq. ft.)
- $Q_{i,t}$: Heat conducted into i-th surface at time t, Btu per (hr) (sq. ft.)
- GL_t : Mass air flow rate due to air leakage at time t, lb per hr
- GS_t : Mass air flow rate of the supply air from the central system at time t, lb per hr
- QEQUP: Internal heat generated from equipment such as business machines and computers, Btu per hr
- QOCPS: Internal heat (sensible) generated from occupants (a function of room air temperature), Btu per hr
- QLITE: Heat from lights, Btu per hr
- RE: Fraction of internal heat gain from equipment that can be assumed to be convective
- RO: Fraction of internal heat gain from occupants that can be assumed to be convective
- RL: Fraction of heat gain from lights that can be assumed to be convective

SHG_{i,t}: Solar incident radiation on i-th surface at time t,
 Btu per (hr) (sq. ft.)

Calculation Sequence:

1. Heat balance equation at the i-th surface at time t

$$Q_{i,t} = \sum_{j=0}^{N_i} X_{i,j} * TIS_{i,t-j} - \sum_{j=0}^{N_i} Y_{i,j} * TOS_{i,t-j} + R_i * Q_{i,t-1}$$

$$= H_i * (TA_t - TIS_{i,t}) + \sum_{k=1}^{NS} G_{i,k} * (TI_{k,t} - TI_{i,t}) + R_{i,t}$$

where $G_{i,k} = 4 * E_i * F_{i,k} * (TA_t + 460) ** 3 * 0.1714 * 10 ** -8$

$$R_{i,t} = SHG_{i,t} + \frac{((1-RE)*QEQU + (1-RO)*QOCPS + (1-RL)*QLITE)}{\sum_{i=1}^{N_s} S_i}$$

2. Heat balance for the room air

$$\sum_{i=1}^{N_s} S_i * (TIS_{i,t} - TA_t) + GL_t * C_p * (DB - TA_t) + GS_t * C_p *$$

$$(TS_t - TA_t) + QEQU * RE + QOCPS * RO + QLITE * RL = 0$$

where C_p is the specific heat of air in Btu per (lb) (F)

The values of GS_t and TS_t, supply air flow rate and its temperature, are the link between the load calculation and the system simulation. (More detailed explanation of this aspect is given in the final portion of this section.)

3. Assigning matrix elements for $i = 1, 2, 3, \dots, NS$ and for
 $k = 1, 2, 3, \dots, NS$

$$A_{i,i} = X_{i,1} + H_i + \sum_{k=1}^{NS} G_{i,k}$$

$$A_{i,k} = -G_{i,k} = A_{k,i} = -G_{k,k}$$

$$A_{i,NS+1} = -H_i$$

$$B_i = -\sum_{j=1}^{N_i} X_{i,j} * TIS_{i,t-j} + \sum_{j=0}^{N_i} Y_{i,j} * TOS_{i,t-j} - R * Q_{i,t-1} + R_{i,t}$$

$$A_{NS+1,k} = S_k * H_k$$

$$A_{NS+1,NS+1} = -(GL_t + GS_t) * C_p - \sum_{k=1}^{NS} H_k * S_k$$

$$B_{NS+1} = -QEQU*RE + -QOCPS*RO - QLITE*RL - GL_t*C_p*DB_t - GS_t*C_p*TS_t$$

4. Using these matrix elements, the following $NS+1$ equation
 should be solved simultaneously for $TIS_{i,t}$ ($i = 1, 2, \dots, NS$)
 and for TA_t

$$\begin{bmatrix} A_{1,1} & A_{1,2} & & A_{1,NS+1} \\ A_{2,1} & A_{2,2} & & A_{2,NS+1} \\ & & & \\ & & & \\ & & & \\ & & & \\ & & & \\ & & & \\ & & & \\ & & & \\ A_{NS,1} & A_{NS,2} & & A_{NS,NS+1} \\ A_{NS+1,1} & A_{NS+1,2} & & A_{NS+1,NS+1} \end{bmatrix} * \begin{bmatrix} TIS_{1,t} \\ TIS_{2,t} \\ \\ \\ \\ \\ \\ \\ \\ TIS_{NS,t} \\ TA_t \end{bmatrix} = \begin{bmatrix} B_1 \\ B_2 \\ \\ \\ \\ \\ \\ \\ \\ B_{NS} \\ B_{NS+1} \end{bmatrix}$$

5. When the value of TA_t has been specified, as in the case of a controlled condition, the following NS equations should be solved instead of the NS+1 equations given above.

$$\begin{bmatrix} A_{1,1} & A_{1,2} & \dots & A_{1,NS} \\ A_{2,1} & A_{2,2} & & A_{2,NS} \\ & & & \\ \dots & & \dots & \\ A_{NS,1} & A_{NS,2} & & A_{NS,NS} \end{bmatrix} * \begin{bmatrix} TIS_{1,t} \\ TIS_{2,t} \\ \\ \dots \\ TI_{NS,t} \end{bmatrix} = \begin{bmatrix} B'_1 \\ B'_2 \\ \\ \\ B'_{NS} \end{bmatrix}$$

where

$$B'_i = B_i - A_{i,NS+1} * TA_t$$

6. Calculate the sensible load by

$$QLS_t = \sum_{i=1}^{N_s} S_i * (TIS_{i,t} - TA_t) + GL_t * C_p * (DB_t - TA_t) \\ + QEQUP * RE + QOCPS * RO + QLITE * RL$$

In this expression, QL is a cooling load if positive and it is a heating load if negative. This is the heat picked up by the room air (or that lost by the room air) which has to be removed (or added) by the central air conditioning system.

Note that for ordinary load calculations, GS_t and TS_t are not used as long as the following condition is satisfied:

$$| QLS_t | \leq | GS_t * C_p * (TA_t - TS_t) | \dots \text{Maximum capacity} \\ \text{of the heating or cooling system}$$

In other words, the desired or prescribed room temperature can be maintained as long as the calculated load is less than the maximum capacity of the central system. When the above condition is not satisfied because of the inadequate values for either the air supply rate or the supply air temperature, the room temperature used for the load calculation is no longer valid. The calculation must then be revised, first calculating the room temperature as outlined in 3 above.

7. Latent Load

If moisture condensation and absorption by room walls, or drying of the wall panels can be neglected, the latent load is the same as the latent heat gain or loss, provided the following condition is met:

$$QLL_t \leq GS_t * \lambda * (WA - WS), \text{ where } \lambda = \text{latent heat}$$

of vaporization ≈ 1061 Btu per lb of water

In other words, the desired moisture level can be maintained as long as the latent load of the room or the building is less than the capacity of the central system to remove (add) water vapor. When the above condition is not satisfied because of the inadequate air flow rate of the air supply system or the value of WS, the room humidity ratio would change according to

$$WI = \frac{GS_t * WS + GL_t * WA + QLL/\lambda}{GS_t + GL_t}$$

This equation becomes indeterminate when there is no air supply or air leakage to or from the room. Theoretically the room relative humidity would reach 100% soon after the air supply or air leakage is stopped provided normal internal sources were still present. Under those conditions, seasonal value of WI to be used would be that corresponding to the dew point temperature which would be approximately equal to the average

wall surface temperature of the space.

The most important application of RMTMP is for taking into account some of the performance characteristics of the room's (or space's) heating and cooling systems where the evaluation of heating and cooling load is linked to the system capacity. Presented in this section is a sample algorithm to illustrate how RMTMP can be used to account for the type of occupancy, temperature control scheme, and the system capacity. In this illustration, the heating/cooling load will be set equal to the maximum capacity of the system when the calculated load at a given time is greater than the maximum system capacity. The space or room temperature is then calculated on the basis of net load, which is the difference between the calculated load at a given design temperature and the maximum system capacity. If, on the other hand, the space temperature falls within the prescribed upper and the lower limits, the load is set equal to zero. The same procedure is applied to the latent load calculation. The details of the algorithm is depicted in the flow diagram (Figure A-20). The nomenclature for the figure is given in Table A-12.

RELATIONSHIP BETWEEN
TA, TLL, TUL, QLS, QCLDS, QHLDS

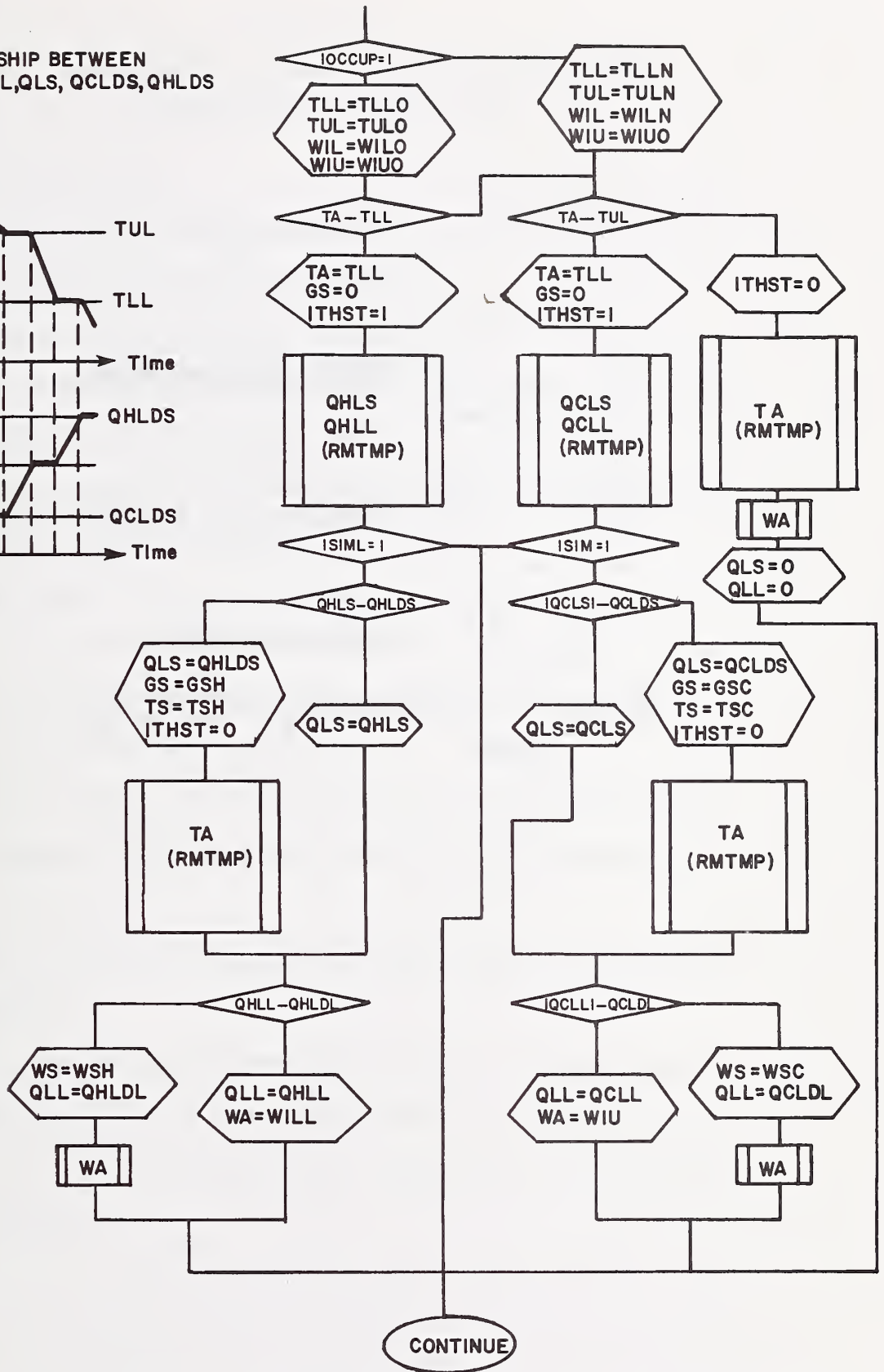
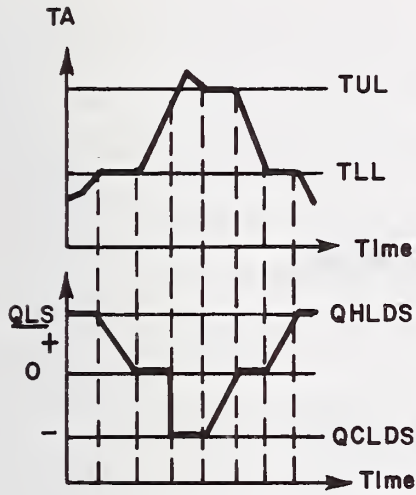

Figure A-20 Flow Diagram of the Room Temperature and the Room Thermal Load Calculation Steps

Symbols used in the flow diagram, Figure A-20



Setting of the variables



Calculation by RMTMP



Calculation of WA



Testing of "yes" or "no"

Table A-12

Nomenclature for Figure A-20

IOCCUP: Occupancy index

1 if during the occupied period

0 if during the unoccupied period

ISIML: System capacity consideration index

1 if the calculated load is to be compared with the maximum capacity of the system

0 if the load is to be estimated without regard to the installed system capacity

ITHST: Room temperature control index

1 if a space temperature is prescribed at a given level and the heating and cooling load is to be calculated to meet this prescribed condition

0 if the space temperature is to be determined as a balance between the required load and the available capacity of the system

TLL: The lower limit of temperature, below which heating must be supplied

TLLO: The lower limit of temperature during the occupied period

TLLN: The lower limit of temperature during the unoccupied period

TUL: The upper limit of temperature, above which cooling must be provided

TULO: The upper limit of temperature during the occupied period

TULN: The upper limit of temperature during the unoccupied period

WIL: The lower limit of humidity ratio, below which the room requires humidification

WILO: The lower limit of humidity ratio during the occupied period

WILN: The lower limit of humidity ratio during the unoccupied period

WIU: The upper limit of humidity ratio, above which the room requires dehumidification

WIUO: The upper limit of humidity ratio during the occupied period

WIUN: The upper limit of humidity ratio during the unoccupied period

GS: Mass flow rate of air from the supply system

GSH: Maximum mass flow rate of air from the supply system during heating

GSC: Maximum mass flow rate of air from the supply system during cooling

TS: Air temperature of the supply air system

TSH: Maximum temperature of air from the supply system during heating

TSC: Minimum temperature of air from the supply system during cooling

WS: Humidity ratio of the air from the supply system

WSH: Maximum humidity ratio of air from the supply system during a period when heating and humidification occur

WSC: Minimum humidity ratio of air from the supply system during a period when cooling and dehumidification occur

C_p : Specific heat of air

λ : Latent heat of vaporization

QHLDS: Maximum system capacity for heating, Btu per hr

$$QHLDS = GSH * C_p * (TSH - TA)$$

QHLDL: Maximum system capacity for humidification

$$QHLDL = GSH * \lambda * (WSH - WA)$$

QCLDS: Maximum system capacity for cooling, Btu per hr

$$QCLDS = GSC * C_p * (TA - TSC)$$

QCLDL: Maximum system capacity for dehumidification

$$QCLDL = GSC * \lambda * (WA - WSC)$$

The primary variables that are determined by this mode of calculation are:

QHLS: Sensible heating load of the space

QHLL: Latent heating load of the space

QCLS: Sensible cooling load of the space

QCLL: Latent cooling load of the space

TA: Space temperature

WA: Space humidity ratio

ATTIC

A Description of the Load Calculation for an Attic Space

In many cases the heating and cooling load in an attic space is affected strongly by the manner in which the attic conditions are maintained. The non-ventilated attic space may be treated as a simple air space within a roof structure and accounted for in the calculation of the conduction transfer functions. Where the attic space is ventilated during the summer to take advantage of the resulting natural cooling effect of the outdoor air, it has to be treated somewhat differently. Since it is reasonable to assume that the radiation heat exchange between the underside of the roof surface and the attic is as significant as the ventilation air rate in determining the attic thermal condition, RMTMP should be used. No additional algorithms are then required since all aspects covered in RMTMP apply directly to the attic heat transfer calculation. Of course, the solar radiation through windows, and internal heat gain from lighting and occupants would most likely be omitted. The floor should be treated as having its exterior surface exposed to the environmental conditions of the room below. The heat loss at the "exterior" surface of the floor then becomes the heat gain to the room beneath the ceiling.

FIJ 1 outlines the calculation procedure for obtaining the necessary shape factors where the attic has a gabled roof.

IHG

An Algorithm to Calculate Instantaneous Heat Gain of a Space at Time t

Data:

Windows:

- NY: Number of windows
- AY_k: Area of each window, sq ft
- UY_k: Overall heat transfer coefficient for each window, Btu per (hr) (sq ft) (f)
- SHG_k: Solar heat gain through each window, Btu per (hr) (sq ft) (Calculated in SHG)

Exterior Walls and Roofs:

- NX: Number of exterior walls and roofs
- AX_k: Area of each exterior wall and roof, sq ft
- HEAT_k: Heat gain through each exterior wall and roof, Btu per (hr) (sq ft) (Calculated in HEATW)
where $k = 1, 2, \dots NX$

Lights:

- NS: Number of different types of lights
- QS_k: Power input to each type of light, Btu per hr
where $k = 1, 2, \dots NS$

Internal Heat Source Other than Lights:

- NS': Number of different types of internal sensible heat sources other than lights
- QS'_k: Heat generation from each internal sensible heat source, where k = 1, 2, ... NS'
- NL: Number of different types of internal latent heat sources
- QL'_k: Latent heat gain from each internal latent heat source, Btu per hr, where k = 1, 2, ... NL

Inside Doors:

- ND: Number of inside doors
- AD'_k: Area of each inside door, sq ft
- UD'_k: Overall heat transfer coefficient of each inside door, where k = 1, 2, ... ND'

Outside Doors:

- ND': Number of outside doors
- AD'_k: Area of each outside door, sq ft
- UD'_k: Overall heat transfer coefficient of each outside door, Btu per (hr) (sq ft) (F), where k = 1, 2, ... ND'

Partitions:

NP: Number of partitions which separate the space from other spaces at different temperatures

AP_k: Area of each of these partitions, sq ft

UP_k: Overall heat transfer coefficient for each of these partition walls, Btu per (hr) (sq ft) (F) where k = 1, 2, ... NP

Underground Walls:

NG: Number of underground walls

AG_k: Area of each underground wall, sq ft

UG_k: Overall heat transfer coefficient of each underground wall, Btu per (hr) (sq ft) (F), where k = 1, 2, ... NG

Underground Floors:

NGF: Number of underground floors

AGF_k: Area of each underground floor, sq ft

UGF_k: Overall heat transfer coefficient of each underground floor, Btu per (hr) (sq ft) (F), where k = 1, 2, ... NGF

Internal Infiltration:

NLK: Number of internal air leakage sources

LEAK_k: Air leakage from each source, cfm (Calculated in INFIL), where k = 1, 2, ... NLK

External Infiltration:

- NLK': Number of external air leakage sources
- LEAK_k': Air leakage from each external source, cfm
(Calculated in INFIL), where k = 1, 2, ...
NLK'

Temperatures:

- TA_k: Dry-bulb temperature of each adjacent space,
F, where k = 1, 2, ... ND, NP or NLK
- DB: Outside air dry-bulb temperature, F (Obtained
from CLIMATE)
- TG: Average ground water temperature at half under-
ground basement depth, F
- TGW: Ground water temperature, F
- TZ: Space dry-bulb temperature, F

Humidity Ratios:

- WA_k: Humidity ratio of adjacent space, lb water per
lb dry air, where k = 1, 2, ... ND, NP or NLK
- WO: Outside air humidity ratio, lb water per lb
dry air (Calculated in PSY)
- WZ: Space humidity ratio, lb water per lb dry air

The following heat gains are calculated in this subroutine:

HEATG Total hourly solar heat gain through windows, Btu
or :
HEATG' per hr

HEATK: Total hourly heat gain through exterior walls and
roofs, Btu per hr

HEATIS: Total power input to lights, Btu per hr

HEATDP: Total sensible heat gain due to heat transfer through
doors, partitions, underground walls and floors, and
internal heat sources other than lights, Btu per hr

HEATVS: Total hourly sensible heat gain due to infiltration,
Btu per hr

HEATL: Total hourly latent heat gain due to infiltration and
internal heat sources, Btu per hr

Calculation Sequence:

$$1. \begin{array}{l} \text{HEATG} \quad \text{NY} \\ \text{or} \quad = \sum_{k=1} \text{AY}_k * \text{SHG}_k \\ \text{HEATG}' \end{array}$$

$$2. \text{HEATX} = \sum_{k=1}^{\text{NX}} \text{AX}_k * \text{HEAT}_k$$

$$3. \text{HEATIS} = \sum_{k=1}^{\text{NS}} \text{QS}_k$$

$$4. \text{HEATDP} = \sum_{k=1}^{\text{ND}} \text{AD}_k * \text{UD}_k * (\text{TA}_k - \text{TZ}) + \sum_{k=1}^{\text{ND}'} \text{AD}_k' * \text{UK}_k' (\text{DB} - \text{TZ})$$

$$\begin{aligned}
& + \sum_{k=1}^{NY} AY_k * UY_k * (DB-TZ) + \sum_{k=1}^{NG} AG_k * UG_k * (TG-TZ)^* \\
& + \sum_{k=1}^{NGF} AGF_k * UGF_k * (TGW-TZ) + \sum_{k=1}^{NP} AP_k * UP_k * (TA_k - TZ) \\
& + \sum_{k=1}^{NS'} QS'_k
\end{aligned}$$

$$5. \text{ HEATVS} = 1.08 * \left(\sum_{k=1}^{NLK} LEAK_k * (TA_k - TZ) + \sum_{k=1}^{NLK'} LEAK'_k * (DB-TZ) \right)^{**}$$

$$6. \text{ HEATL} = 4775 * \left(\sum_{k=1}^{NLK} LEAK_k * (WA_k - WZ) + \sum_{k=1}^{NLK'} LEAK'_k * (WO-WZ) \right)$$

$$+ \sum_{k=1}^{NL} QL_k \frac{**}{\rho}$$

* The values of UG given in the 1972 ASHRAE Handbook of Fundamentals are based on TGW. A program for calculating basement wall losses using TC has been developed at the National Bureau of Standards. When using present ASHRAE values for UG, use TGW instead of TG.

** The coefficients 1.08 and 4775 in these equations are valid for the standard air density. If desired, they can be adjusted to actual conditions by multiplying both of them by $\frac{\rho}{0.075}$, where ρ is the actual density of the air expressed in lb per cu ft.

HLC

A Simplified Procedure for Obtaining Approximate Cooling Load
by the Use of Weighting Factors

The procedure presented here was developed by Mitalas and Stephenson of National Research Council of Canada^{13, 14/} in order to expedite the otherwise complex and time-consuming solution of the heat balance simultaneous equations. The rigorous solution similar to that described in RMTMP was first obtained for typical rooms in commercial buildings with pulse type excitations that simulate various heat gains. The solution for these pulse excitations were then converted into new types of transfer functions called Weighting Factors. Weighting Factors developed for typical office spaces of light, medium, and heavy constructions are shown in Tables A-13, A-14, and A-15 for solar heat gain with no internal shading devices; heat gain conduction through interior and exterior structure components, solar heat gain with interior shading devices and all internal sources except lighting; and the heat gain due to lighting. By multiplying these Weighting Factors to the history of respective heat gains in a convolution scheme, similar to the way the conduction transfer functions are multiplied to the temperature history, it is possible to calculate an approximate cooling load.

Data:

AG_j for $j = 0, 1, 2 \dots MG$ and BG_j for $j = 1, 2, 3 \dots MG'$

Weighting Factors for the solar heat gain HEATG
(no internal shading devices)

AX_j for $j = 0, 1, 2 \dots MX$ and BX_j for $j = 1, 2 \dots MX'$

Weighting factors for

HEAT: Conduction heat gain

HEATG: Solar heat gain where there are internal shading devices

HEATDP: Heat gain due to air leakage and internal sources except lighting

AIS_j for $j = 0, 1, 2 \dots MIX$ and BIS_j for $j = 1, 2, 3 \dots MIS'$

Weighting factors for the heat gain from lighting HEATIS

In order to make use of the weighting factor concept, it is necessary to have previous values of heat gains as well as values of cooling loads. By denoting the cooling load due to HEATG as HLCG, due to HEATX, HEATG', and HEATDP as HLCX and that due to HEATIS as HLCIS, the following set of the previous data are needed:

| | |
|---|--------------------------------|
| $HEATG_{t-j}$ | for $j = 0, 1, 2 \dots MG$ |
| $HEATX_{t-j}; HEATG'_{t-j}; HEATDP_{t-j}$ | for $j = 0, 1, 2 \dots MX$ |
| $HEATIS_{t-j}$ | for $j = 0, 1, 2, 3 \dots MIS$ |
| $HLCG_{t-j}$ | for $j = 1, 2, 3 \dots MG'$ |
| $HLCX_{t-j}$ | for $j = 1, 2, 3 \dots MX'$ |
| $HLCIS_{t-j}$ | for $j = 1, 2, 3 \dots MIS'$ |

Calculation Sequence:

1. Using the Weighting Factors* given in Tables A-13, A-14, and

* The Weighting Factors given in Tables A-13, A-14, and A-15 are for typical office construction. They are obtained using the method described in Appendix B.

A-15 and factor F_c defined by equation "d", calculate load components corresponding to the heat gains.

$$a. \quad HLCG_t = F_c \sum_{j=0}^{MG} AG_j * HEATG_{t-j} - \sum_{j=1}^{MG'} BG_j * HLCG_{t-j}$$

$$b. \quad HLCX_t = F_c \sum_{j=0}^{MX} AX_j * (HEATX_{t-j} + HEATG'_{t-j} + HEATDP_{t-j}) - \sum_{j=1}^{MX'} BX_j * HLCX_{t-j}$$

$$c. \quad HLCIS_t = F_c \sum_{j=0}^{MIS} AIS_j * HEATIS_{t-j} - \sum_{j=1}^{MIS'} BIS_j * HLCIS_{t-j}$$

The coefficients given in Tables A-13, A-14, and A-15 are for the case where all the heat gain energy appears eventually as cooling load. In most cases, a fraction of the input is lost to the surroundings. This fraction depends on the thermal conductance between the room air and the surroundings. One estimate of this fraction F_c , is given by

$$d. \quad F_c = 1 - 0.02 K_T \dots$$

for the range $1.0 > F_c > 0.7$

$$\text{where } K_T = \frac{1}{L_F} (U_{\text{window}} A_{\text{window}} + U_{\text{exterior wall}} A_{\text{exterior wall}} + U_{\text{corridor wall}} A_{\text{corridor wall}})$$

* A U*A product should also be included for walls that adjoin unconditioned spaces even though the walls are not exterior ones.

L_F = Length of room exterior perimeter

U = U value of the room enclosure element

A = Area of the room enclosure element

2. Hourly load

a. Sensible load

$$SCL_t = HLCG_t + HLCX_t + HLCIS_t + HEATVS_t$$

b. Latent load

$$= HEATL_t$$

Table A-13

WEIGHTING FACTORS FOR HEATG

| | Weighting Factor Symbol | Heavy* Structure | Medium* Structure | Light* Structure |
|---------|-------------------------------|---------------------|----------------------|---------------------|
| MG = 1 | AG ₀ | 0.187 | 0.197 | 0.224 |
| | AG ₁ | -0.097 | -0.067 | -0.044 |
| MG' = 1 | BG ₀ | 1.00 | 1.00 | 1.00 |
| | BG ₁ | -0.91 | -0.87 | -0.82 |

* Heavy Structure - 6" concrete floor slab, 6" concrete exterior wall, approximately 130 lb of building material per sq. ft. of floor area.

Medium Structure - 4" concrete floor slab, 4" concrete exterior wall, approximately 70 lb of building material per sq. ft. of floor area.

Light Structure - 2" concrete floor slab, exterior frame wall approximately 30 lb of building material per sq. ft. of floor area.

Table A-14

NORMALIZED WEIGHTING FACTORS FOR HEATX + HEATG' + HEATDP

| | Weighting Factor Symbol | Heavy Structure | Medium Structure | Light Structure |
|---------|-------------------------------|--------------------|---------------------|--------------------|
| MX = 1 | AX ₀ | 0.676 | 0.681 | 0.703 |
| | AX ₁ | -0.586 | -0.551 | -0.523 |
| MX' = 1 | BX ₀ | 1.00 | 1.00 | 1.00 |
| | BX ₁ | -0.91 | -0.87 | -0.82 |

Table A-15

WEIGHTING FACTORS FOR HEATIS

| Weighting Factor Symbol | Heavy Structure | Medium Structure | Light Structure | |
|---|--------------------|---------------------|--------------------|-------|
| Fluorescent fixtures recessed into a suspended ceiling, ceiling plenum not vented. | | | | |
| MIS = 2 | AIS ₀ | 0.00 | 0.00 | 0.00 |
| | AIS ₁ | 0.53 | 0.53 | 0.53 |
| | AIS ₂ | -0.44 | -0.40 | -0.35 |
| * Fluorescent fixtures recessed into a suspended ceiling, return air through ceiling plenum. | | | | |
| MIS = 2 | AIS ₀ | 0.00 | 0.00 | 0.00 |
| | AIS ₁ | 0.59 | 0.59 | 0.59 |
| | AIS ₂ | -0.50 | -0.46 | -0.41 |
| Fluorescent fixtures recessed into a suspended ceiling, supply and return air through fixtures. | | | | |
| MIS = 2 | AIS ₀ | 0.00 | 0.00 | 0.00 |
| | AIS ₁ | 0.87 | 0.87 | 0.87 |
| | AIS ₂ | -0.78 | -0.74 | -0.69 |

* Manufacturer's data sheet must be consulted to obtain the fractions of light input energy that are picked up by the room air and by ventilation air in the ceiling plenum.

Table A-15 continued

| | Weighting Factor Symbol | Heavy Structure | Medium Structure | Light Structure |
|--|-------------------------------|--------------------|---------------------|--------------------|
| Incandescent lights exposed in the room air. | | | | |
| | AIS ₀ | 0.00 | 0.00 | 0.00 |
| MIS = 2 | AIS ₁ | 0.50 | 0.50 | 0.50 |
| | AIS ₂ | -0.41 | -0.37 | -0.32 |
| The "BIS" Coefficients. | | | | |
| | BIS ₀ | 1.00 | 1.00 | 1.00 |
| MIS' = 1 | BIS ₁ | -0.91 | -0.87 | -0.82 |

RMRT

An Algorithm For Calculating Weighting Factors for Space Air Temperature

This algorithm provides a sample calculation method for obtaining the weighting factors for deviation of space temperature from the design value; the value at which the space heating/cooling loads are obtained for by the HLC routine.

This general algorithm illustrated here is for a space enclosure surrounded with spaces on both sides as well as above and below that are thermally at the same conditions. The space enclosure consists of an external wall, interior partition walls, corridor partition wall, ceiling, floor, furnishings, an outside door and a window.

Data:

- AF: Floor area, sq. ft.
- AC: Ceiling area, sq. ft.
- AP: Interior partition wall area, sq. ft.
- AK: Corridor wall area, sq. ft.
- AW: Exterior wall area, sq. ft.
- AG: Window glass area, sq. ft.
- AD: Door area, sq. ft.
- AFN: Internal furnishings area, sq. ft.
- BF_j: Transfer functions for floor, Btu per (hr) (sq. ft.)
- CF_j: (F), (Calculated in XYZ)
- DF_j

BC_j Transfer functions for ceiling, Btu per (hr) (sq. ft.)
 CC_j : (F), (Calculated in XYZ)
 DC_j
 BK_j Transfer functions for corridor wall, Btu per (hr) (sq.
 DK_j : ft.) (F), (Calculated in XYZ)
 BP_j Transfer functions for interior partition walls, Btu per
 CP_j : (hr) (sq. ft.) (F), (Calculated in XYZ)
 DP_j
 CW_j Transfer functions for exterior walls, Btu per (hr) (sq.
 DW_j : ft.) (F), (Calculated in XYZ)
 CD_j Transfer functions for outside door, Btu per (hr) (sq.
 DD_j : ft.) (F), (Calculated in XYZ)
 CFN_j Transfer functions for internal furnishings, Btu per (hr)
 DFN_j : (sq. ft.) (F), (Calculated in XYZ)

where $j = 0, 1, \dots, M$

UG: Heat transmission coefficient of window glass, Btu per
 (hr) (sq. ft.) (F)

CFM: Rate of air flow through the room, cu ft per min.
 (Ventilation rate)

Calculation Sequence:

1. Conversion of the given transfer functions into single series x_j , y_j , and z_j . This calculation is a polynomial division*, i.e.,

$$\begin{aligned} & x_0 z^0 + x_1 z^{-1} + x_2 z^{-2} + x_3 z^{-3} + \dots \\ &= \frac{a_0 z^0 + a_1 z^{-1} + a_2 z^{-2} + \dots}{1 + b_1 z^{-1} + b_2 z^{-2} + b_3 z^{-3} + \dots} \end{aligned}$$

where

$x_0, x_1, x_2 \dots$ = single series response factor set

$a_0, a_1, a_2 \dots$ and

$b_1, b_2, b_3 \dots$ = coefficient of the given numerator

and denominator series respectively

For example, using given notation in this section for the outside wall, the x's, a's and b's are

| | | |
|---------------|--------------|--------------|
| $x_0 = sCW_0$ | $a_0 = CW_0$ | $b_0 = 1.0$ |
| $x_1 = sCW_1$ | $a_1 = CW_1$ | $b_1 = DW_1$ |
| $x_2 = sCW_2$ | $a_2 = CW_2$ | $b_2 = DW_2$ |
| . | . | $b_3 = DW_3$ |
| . | . | . |
| . | . | . |

* The rules of polynomial division can be obtained from any standard textbooks on numerical analysis.

where the letter "s" in front of CW_j denotes coefficients of the single series.

2. Calculation of the single series of Room Air Response Factors, sRMRT. The factors in this series are given by

$$\begin{aligned} \text{sRMRT}_j = & \text{AF}[\text{sBF}_j + \text{sCF}_j] \\ & + \text{AC}[\text{sDC}_j + \text{sCC}_j] \\ & + \text{AP}[\text{sBP}_j + \text{sCP}_j] \\ & + \text{AW}[\text{sCW}_j] \\ & + \text{AD}[\text{sCD}_j] \\ & + \text{AFN}[\text{sCFN}_j] \\ & + \text{AG}[\text{UG}_j]^* \\ & + 1.08[\text{CFM}_j]^* \end{aligned}$$

where $j > 10$ calculate the ratio R_j

$$R_j = \frac{\text{sRMRT}_{j+1}}{\text{sRMRT}_j}$$

and when $|R_j - R_{j+1}| \leq 0.001$ terminate sRMRT_j calculations.

3. Calculation of RMRT

The calculation of RMRT as a ratio of two series consists of three steps:

- (a) Calculation of denominator, $D(z)$,

$$D(z) = 1.0 - Rz^{-1}$$

where R is the last value of the ratio calculated in the sRMRT_j calculations.

* Note that $\text{UG}_{j=1} = \text{UG}$, $\text{CFM}_{j=1} = \text{CFM}$, $\text{UG}_{j>1} = 0.0$ and $\text{CFM}_{j>1} = 0.0$.

(b) Calculation of numerator, $N(z)$,

$$\begin{aligned} N(z) = & \text{sRMRT}_0 z^0 + (\text{sRMRT}_1 - (R)\text{sRMRT}_0) z^{-1} \\ & + (\text{sRMRT}_2 - (R)\text{sRMRT}_1) z^{-2} \\ & + (\text{sRMRT}_3 - (R)\text{sRMRT}_2) z^{-3} \end{aligned}$$

(c) The RMRT's are then evaluated by equating the following equation to the one in (b) above

$$N(z) = \frac{X_0 + X_1 z^{-1} + X_2 z^{-2}}{Y_0 + Y_1 z^{-1}}$$

Typical values are shown in Table A-16.

Table A-16

WEIGHTING FACTORS FOR THE DEVIATION OF SPACE
TEMPERATURE, RMRT 'S*

| | Weighting Factor Symbol | Heavy Structure | Medium Structure | Light Structure |
|--------|-------------------------------|--------------------|---------------------|--------------------|
| | X_0 | -1.85 | -1.81 | -1.68 |
| | X_1 | +1.95 | +1.89 | +1.73 |
| MX = 2 | X_2 | -0.10 | -0.08 | -0.05 |
| | Y_0 | 1.00 | 1.00 | 1.00 |
| MY = 1 | Y_1 | -0.91 | -0.87 | -0.82 |

* The X coefficients given in this Table are for a room with zero heat conductance to surrounding spaces and are normalized to unit floor area. To get the X_j coefficients for a room with a total conductance K between room air and surroundings, ventilation rate V_t and infiltration rate VI_t it is necessary to multiply each X_j value by room floor area and then add $[K + (V_t + VI_t) 1.08] (1.00^j - Y_j)$ to the resulting X_0 value (where V_t and VI_t are in cfm and K is in Btu/hr °F.

Note: That X_0 value changes with the changes of V_t and VI_t values.

HEXT

An Algorithm for Calculating the Rate at Which
Sensible Heat is Extracted From the Space

Data:

- SCL_t : Sensible cooling load at time t , which is calculated for a constant space design temperature of TM , Btu per hr
(Calculated in HCL)
- X_j : Weighting factors for use with θ_{t-j} , for $j = 0, 1, \dots$,
 Y_j : (Calculated in RMRT with typical values shown in Table A-16)
- θ_{t-j} : History of hourly space air temperature deviation from the assumed constant value TM , for $j = 1, 2 \dots, F$
- C : Average heat extraction rate of the apparatus in a space when the space air temperature is TM , Btu per hr
- D : Change in the rate of heat extraction of the apparatus caused by one degree change in space air temperature, Btu per (hr) (F)
- HE_{t-j} : History of heat extracted from the space, for $j = 1, 2 \dots$, Btu per hr

INFIL

An Algorithm for Calculating Air Infiltration

It is well recognized that the air infiltration constitutes as much as 30% of home heating load and a significant part of the load of non-pressurized commercial buildings. The air leakage of a building depends upon the tightness of its exterior walls, windows, and doors, the wind characteristics and temperature difference between the inside and outside, and to some extent how the building is operated with respect to the opening and closing of its door.

The rate of air infiltration can be empirically expressed by

$$Q = C \cdot A \cdot \Delta P^N$$

where

Q: air flow rate

C: flow coefficient

A: flow opening area

N: pressure exponent

ΔP : pressure difference

Unfortunately it is very difficult to determine accurate values of flow opening area and pressure difference for actual buildings, which consist of complex air leakage passages. A limited amount of data are given in the 1972 ASHRAE Handbook of Fundamentals for equivalent opening area of typical windows, doors and walls. The pressure difference depends upon the wind characteristics around the building and the temperature differ-

ence between the inside and the outside of the building.

Compiled in this section is a methodology to approximately calculate the pressure difference between a given space and its adjacent space including the outdoor. The basic mathematical principle involved is to attain a solution to a set of pressure difference equations of the following type:

$$Q_i = \sum Q_{i,k} = 0$$

$$Q_{i,k} = \sum A_{i,k} * C_{i,k} * (P_i - P_k)^{N_{i,k}}$$

where

- Q_i : net air flow out of space i
- $Q_{i,k}$: air exchange between space i and space k
- $A_{i,k}$: flow opening area between space i and k
- $C_{i,k}$: flow coefficient applicable to the air flow between the spaces i and k
- $N_{i,k}$: pressure exponent applicable to the flow between the spaces i and k

A special computational routine is required to solve this set of simultaneous, non-linear equations.

As mentioned previously, air leakage through various openings such as doors, windows, window frames, pinholes in the wall and service shafts may be approximated by an equation of the following type:

$$\begin{aligned} \text{LEAK} &= 4000 * A * K * (\text{DP}) ** N \\ &= C * (\text{DP}) ** N \end{aligned}$$

where

LEAK = air leakage in cu. ft per min.

A = opening area, sq. ft

K = flow coefficient, dimensionless

DP = pressure difference across the opening, inches of water

N = pressure exponent, dimensionless

C = equivalent flow coefficient (EFC)

The values of K and N vary depending upon the type of opening. Moreover, the exact value of A is not well known for many types of openings, such as wall pinholes or cracks around the windows. Table A-17 lists the values of Equivalent Flow Coefficient C and the flow exponent N for various types of openings common to many buildings. These values are derived from the air leakage data compiled in Chapter 19 "Infiltration and Natural Ventilation" of the 1972 ASHRAE Handbook of Fundamentals.

Table A-17

| | <u>C</u> | <u>N</u> |
|--|----------|----------|
| 1. Double-hung wooden windows (locked)* | | |
| non-weatherstripped loose fit | 6 | 0.66 |
| average fit | 2 | 0.66 |
| weatherstripped loose fit | 2 | 0.66 |
| average fit | 1 | 0.66 |
| 2. Window frames* | | |
| masonry frame with no caulking | 1.2 | 0.66 |
| masonry frame with caulking | 0.2 | 0.66 |
| wooden frame | 1 | 0.66 |
| 3. Swinging doors* 1/2" crack | 160 | 0.5 |
| 1/4" crack | 80 | 0.5 |
| 1/8" crack | 40 | 0.5 |
| 4. Walls** | | |
| 8" plain brick | 1 | 0.8 |
| 8" brick and plaster | 0.01 | 0.8 |
| 13" brick | 0.8 | 0.8 |
| 13" brick and plaster | 0.004 | 0.7 |
| 13" brick, furring, lath and plaster | 0.03 | 0.9 |
| frame wall, lath and plaster | 0.01 | 0.55 |
| 24" shingles on 1 x 6 boards on 14" center | 9 | 0.66 |
| 16" shingles on 1 x 4 boards on 5" center | 5 | 0.66 |
| 24" shingles on shiplap | 3.6 | 0.7 |
| 16" shingles on shiplap | 1.2 | 0.66 |

* Values of C listed for these openings are per ft of linear crack length.

** Values of C listed for the walls are per unit area of the wall surface.

In many instances, detailed information of air leakage characteristics is not available, but it is still possible to make a calculation. For a modern office building of 120 ft x 120 ft plan dimension with the floor height of 12 ft, Tamura^{15/} lumped together all the leakage area for a given floor as follows:

Table A-18

| | |
|---|----------------------------------|
| outside wall | 2.5 sq. ft per story |
| 4 elevator shaft doors | 4.5 " " " " |
| 2 stair shaft doors | 0.5 " " " " |
| floor | 3.7 " " " " |
| branch perimeter and interior air duct | 7.0 " " " " |
| return duct | 14.0 " " " " |
| vertical shafts (elevator or stairwell) | 1/3 of the cross-sectional area* |

The value of C corresponding to these data can be obtained by multiplying them by 2400 which corresponds to $K = 0.6$.

Data:

V: Wind speed measured at a 40 ft elevation as taken from the weather tape, knots.

DIR: Wind direction measured clockwise from North, degrees

(see Figure A-21)

* This particular data were derived from a recent and unpublished experiment of the National Bureau of Standards conducted on two high-rise buildings.

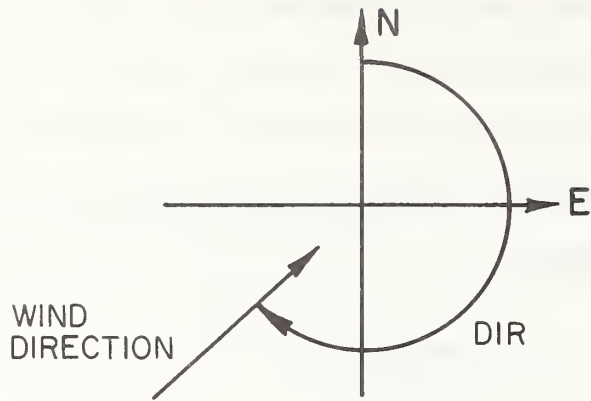

Figure A-21 Definition of Wind Direction Angle

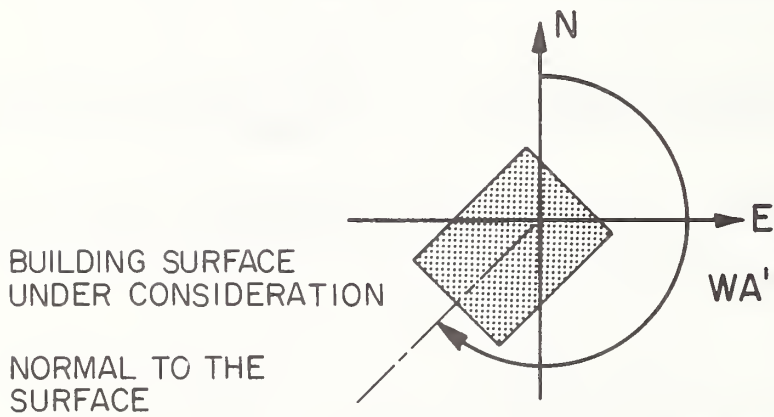

Figure A-22 Definition of the Angle Between North and Normal of the Surface Under Consideration

DB: Outdoor air dry-bulb temperature, F

PB: Barometric pressure, in. Hg.

NF: Number of above-grade floors

HTT: Total height of building (from above-grade), ft.

TZ: Indoor air temperature, F

TS: Elevator and service shaft temperature

WA': Direction angle of the building as defined with respect to North and the normal of the principal surface of the building (see Figure A-22)

HT_k: Height of the floor, ft, for k = 1, 2, 3, NF

CFMSP_k: Ventilation air supplied to the floor, cu ft per min, for k = 1, 2, 3, ... NF

CFMEX_k: Ventilation air exhausted from the floor, cu ft per min, for k = 1, 2, 3, ... NF

Calculation Sequence:

1. $V' = 1.153 * V$
 $TO = 460 + DB$
 $TI = 460 + TZ$
 $PO = 0.4910 * PB$
 $x = DIR - WA'$
2. Wind velocity, VH, at height HT on the building, mph
 $VH = V' * 0.117 * (1 + 2.81 * \text{Log} (0.305 * HT + 4.75))$
3. Theoretical wind velocity pressure, PTWV on the building, in. H₂O
 $PTWV = 0.000482 * (V ** 2)$

4. Wind direction, BWD, relative to building surfaces

BWD = 1 surface on windward side if,

$$-45^\circ < x < +45^\circ$$

BWD = 2 surface on leeward side if,

$$90^\circ < x < 270^\circ$$

or, $-90^\circ < x < -270^\circ$

BWD = 3 surface on side if,

$$45^\circ < x < 90^\circ$$

or, $-45^\circ < x < 90^\circ$

5. Using Table A-19, determine the normal wind velocity pressure correction factor, PTKN.

Table A-19 Values of PTKN

| NSB | TB = 1 | | | TB = 2 | | | TB = 3 | | |
|----------|---------|---------|---------|---------|---------|---------|---------|---------|---------|
| | BWD = 1 | BWD = 2 | BWD = 3 | BWD = 1 | BWD = 2 | BWD = 3 | BWD = 1 | BWD = 2 | BWD = 3 |
| 0.5 | .1 | -.3 | -.8 | -.5 | -.25 | -.45 | .5 | .45 | .45 |
| 1.0 | -.1 | -.25 | -.5 | -.5 | -.2 | -.3 | .45 | .3 | .3 |
| 2.0 | .1 | -.25 | -.4 | .0 | -.2 | -.3 | .45 | .1 | .1 |
| 3.0 | .1 | -.25 | -.4 | .1 | -.2 | -.35 | .45 | .0 | .0 |
| 5.0 | .25 | -.35 | -.6 | .25 | -.25 | -.45 | .5 | -.1 | -.1 |
| ∞ | .6 | -.35 | -.7 | .6 | -.35 | -.7 | .6 | -.35 | -.7 |

where

TB = 1: Shorter building on windward side

TB = 2: Equals taller building on windward side

TB = 3: Taller building on leeward side

6. Wind velocity pressure correction factor, PTKO, for winds obliquely to the wall surface.

If BWD = 1 (windward side of building)

$$(PTKO)_m = \text{Cos} (| x |)$$

If BWD = 2 (leeward side of building)

$$(PTKO)_l = 1.0$$

If BWD = 3 (side of building)

$$(PTKO)_s = \text{Cos} (| x |)$$

Example:

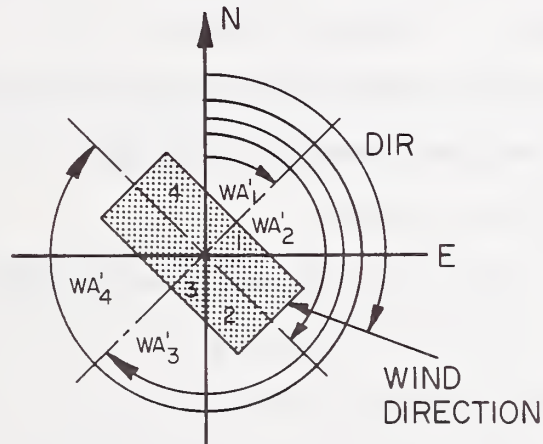

DIR = 110°

WA'_1 = 45°

WA'_2 = 135°

WA'_3 = 225°

WA'_4 = 315°

Figure A-23 DIR and WA' Angles of Example

Side 1, $DIR-WA_1' = 110^\circ - 45^\circ = 65^\circ$ (therefore, BWD = 3)

Side 2, $DIR-WA_2' = 110^\circ - 135^\circ = -25^\circ$ (therefore, BWD = 1)

Side 3, $DIR-WA_3' = 110^\circ - 225^\circ = 115^\circ$ (therefore, BWD = 2)

Side 4, $DIR-WA_4' = 110^\circ - 205^\circ = 205^\circ$ (therefore, BWD = 2)

Side 1, $(PTKO)_s = \text{Cos } (+65^\circ)$

Side 2, $(PTKO)_m = \text{Cos } (+25^\circ)$

Side 3, $(PTKO)_1 = 1.0$

Side 4, $(PTKO)_1 = 1.0$

7. Actual wind pressure on the building at height (HT) corresponding to floor (k): $(PAWV)_k$

$$(PAWV)_k = (PTKO)_k * (PTKN)_k * (PTWV),$$

8. Stack effect pressure (PSE) on the outside of the building at building height (HT) and floor (k), in. H_2O

$$(PSE)_k = -0.52 * PO * HT/TO$$

9. Total pressure on the outside of the building (PCO) at floor (k), in. H_2O

$$(PCO)_k = (PAWV)_k + (PSE)_k$$

10. Pressure in the elevator and serve shafts (PSE) at height (HT) corresponding to floor (k), in. H_2O

$$(PSE)_k = -0.52 * PO * HT/TI + (PSE)_1$$

11. Choose appropriate flow coefficients and pressure exponents for air leakage paths of each floor as follows:

Flow coefficients

CWD: Value of C for appropriate window in Table A-17 multiplied by the total crack length of all the windows

- CFM: Value of C for appropriate window frame in Table A-17 multiplied by the total crack length of all the window frames
- CDR: Value of C for appropriate door in Table A-17 multiplied by the total crack length of all the doors
- CWL: Value of C for appropriate walls in Table A-17 multiplied by the total wall area
- CCL: Value of A for the ceiling from Table A-18 multiplied by 2400
- CFL: Value of A for the floor from Table A-18 multiplied by 2400
- CEL: Value of C for elevator doors
- CSS: Value of C for the doors to the service shaft
- CFS and CES: Value of the cross section of the shaft multiplied by 800

Pressure exponent

- NWD: Value of N for the appropriate window in Table A-17
- NFM: Value of N for the appropriate window frame in Table A-17
- NDR: Value of N for the appropriate door in Table A-17
- NWL: Value of N for the appropriate wall in Table A-17
- NCL: 0.5
- NFL: 0.5

NEL: 0.5

NSS: 0.5

NFS: 0.5

NSE: 0.5

12. Solution of 2 * NF equations

Outdoor air leakage to k-th floor rooms* (see Figure A-23)

Window k leakage

$$\text{LEAKWD}_{k,j} = \text{CWD}_{k,j} * (\text{PCO}_{k,j} - \text{PI}_k) ** \text{NWD}_{k,j} \quad (1)$$

Window frame leakage

$$\text{LEAKFM}_{k,j} = \text{CFM}_{k,j} * (\text{PCO}_{k,j} - \text{PI}_k) ** \text{NFM}_{k,j} \quad (2)$$

Door leakage

$$\text{LEAKDR}_{k,j} = \text{CDR}_{k,j} * (\text{PCO}_{k,j} - \text{PI}_k) ** \text{NDR}_{k,j} \quad (3)$$

Wall leakage

$$\text{LEAKWL}_{k,j} = \text{CWL}_{k,j} * (\text{PCO}_{k,j} - \text{PI}_k) ** \text{NWL}_{k,j} \quad (4)$$

Ceiling leakage

$$\text{LEAKCL}_k = \text{CCL}_k * (\text{PI}_{k+1} - \text{PI}_k) ** \text{NCL}_k \quad (5)$$

Floor leakage

$$\text{LEAKFL}_k = \text{CFL}_k * (\text{PI}_{k-1} - \text{PI}_k) ** \text{NFL}_k \quad (6)$$

* In all of above expressions, subscript k refers to the k-th floor and subscript j refers to the j-th side of the building where the convention is j = 1 (south), 2 (west), 3 (north), and 4 (east).

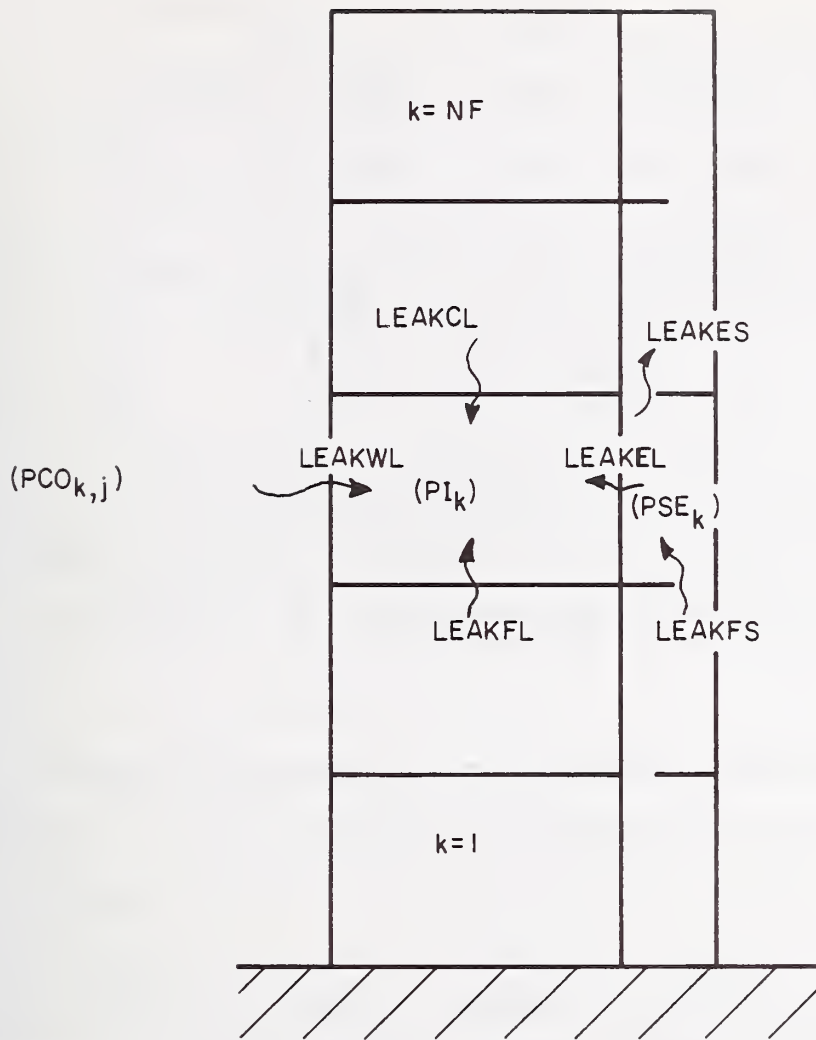

Figure A-23 Air Leakage Pattern of a High-Rise Building

Leakage from the elevator and service shafts*

$$\text{LEAKEL}_k = \text{CEL}_k * (\text{PSE}_k - \text{PI}_k) ** \text{NEL}_k \quad (7)$$

$$\text{LEAKSS}_k = \text{CSS}_k * (\text{PSE}_k - \text{PI}_k) ** \text{NSS}_k \quad (8)$$

Air leakage between the floor levels within the shafts^{*/}

$$\text{LEAKFS}_k = \text{CFS}_k * (\text{PSE}_{k-1} - \text{PSE}_k) ** \text{NFS}_k \quad (9)$$

$$\text{LEAKES}_k = \text{CES}_k * (\text{PSE}_{k-1} - \text{PSE}_k) ** \text{NSE}_k \quad (10)$$

In the previous equations, unknowns are PI_k for $k = 1, 2, 3, \dots$ NF and PSE_k for $k-1, 2, 3 \dots$ NF provided that the pressures in all the shafts are assumed equal at a given floor level.

Flow balance equations at the k-th floor (the individual quantities come from equations 1-10 above)

Rooms

$$\begin{aligned} &\text{LEAKWD}_{k,j} + \text{LEAKFM}_{k,j} + \text{LEAKDR}_{k,j} + \text{LEAKWL}_{k,j} + \text{LEAKCL}_k \\ &+ \text{LEAKFL}_k + \text{LEAKEL}_k + \text{LEAKSS}_k + \text{CFMSP}_k - \text{CFMEX}_k = 0 \end{aligned}$$

* In all of above expressions, subscript k refers to the k-th floor and subscript j refers to the j-th side of the building where the convention is $j = 1$ (south), 2 (west), 3 (north), and 4 (east).

Elevator Shaft or Service Shaft

$$\text{LEAKFS}_k + \text{LEAKES}_k - \text{LEAKEL}_k^* + \text{CFMSPS}_k - \text{CFMEXS}_k = 0$$

where CFMSPS_k : ventilation air supplied at the
k-th floor in the shaft

CFMEXS_k : air exhausted from the shaft at
the k-th floor

These $2 * \text{NF}$ sets of flow balance equations must be solved by an appropriate iteration technique to obtain the pressure profiles in the building and in the shafts. Then the calculated pressure values are used to determine the air leakage of the building.

Recently a comprehensive computer program that embodies the basic algorithm described in this section was published by D. M. Sander and G. T. Tamura of the National Research Council of Canada. The details of the program are given in an NRC booklet entitled "A Fortran IV Program to Simulate Air Movement in Multi-Storey Buildings", DBR Computer Program No. 35, (March 1973).

* If this equation were for a service shaft, LEAKEL_k would be replaced by LEAKES_k .

DST

An Algorithm for Determining the Dates of the Daylight Savings Time

Data:

YR: Year AD

MO: Month of the year

DAY: Day of the month

The main variables calculated in this subroutine are:

DSTX: The day when daylight savings time commences

DSTY: The day when standard time resumes

DST: The daylight savings time indicator

DST = 0 during the standard time period
DST = 1 during the daylight savings time period

Calculation Sequence:

1. If MO is less than 4 or greater than 10, DST = 0.

If MO is greater than 4 and less than 10, DST = 1.

2. If MO = 4, DAY is less than 25, DST = 0.

If DAY is greater than 23, call WKDAY subroutine.

If DAY is Sunday, DSTX = DAY.

If DAY is less than DSTX, DST = 0, otherwise DST = 1.

3. If MO = 10, DAY is less than 25, DST = 1.

If DAY is greater than 24, call WKDAY subroutine.

If DAY is Sunday, DSTY = DAY.

If DAY is less than DSTY, DST = 1, otherwise DST = 0.

WKDAY

An Algorithm Used to Identify the Day of the Week for Any Given
Date of the Year From 1901 to 2000

Data:

YR: Year AD

MO: Month of the year

DAY: Day of the month

The variable calculated in this subroutine is WKDAY, the weekday indicator.

1 if Sunday
2 if Monday
3 if Tuesday
WKDAY = 4 if Wednesday
5 if Thursday
6 if Friday
7 if Saturday

Calculation Sequence:

1. Let $FSTDAY(1) = 31$, $FSTDAY(2) = 59$, $FSTDAY(3) = 90$, $FSTDAY(4) = 120$
 $FSTDAY(5) = 151$, $FSTDAY(6) = 181$, $FSTDAY(7) = 212$, $FSTDAY(8) = 243$
 $FSTDAY(9) = 273$, $FSTDAY(10) = 304$, $FSTDAY(11) = 334$, $FSTDAY(12) = 365$
2. Let $N = \text{Integer part of } YR/4$
 $ND = N - 485$
 $IY = 2$, $IADD = 2$
If $ND = 0$, Go to (4)
If ND is less than 0, $ND = -ND$ and $IADD = -2$

3. Repeat the following steps for ND times
 - IY = IY - IADD
 - If IY is greater than 7, IY = IY - 7
 - If IY is equal to 0, IY = 7
 - If IY is less than 0, IY = IY + 7
4. Let MD = YR - N * 4
 - If MD is equal to 0 IWK = IY
 - If MD is equal to 1 IWK = IY + 2
 - If MD is equal to 2 IWK = IY + 3
 - If MD is equal to 3 IWK = IY + 4
 - If IWK is greater than 7, IWK = IWK - 7
 - If MO is not equal to 1 go to 5
 - TDAY = DAY - 1
 - Go to 7
5. Repeat the following for j = 2 through 12
 - If MO is equal to j, let TDAY = FSTDAY (j-1) + Day - 1
 - Otherwise Go to 6
6. If MD is equal to 0 and MO is greater than 2, TDAY = TDAY + 1
7. Let NTX = Integer part of TDAY/7
 - NDX = TDAY - 7 * NTX + IWK
 - If NDX is greater than 7, let NDX = NDX - 7
8. Let WKDAY = NDX
9. If this routine is going to be applied for the period outside 1901-2000, the following additional algorithms must be added.
 - KV = First two digits of YR

KTEST = Last two digits of YR
 If $MO \leq 2$ or $KTEST = 0$, $KV = KV - 1$
 LTEST = Remainder of $KV/4$
 $KV = 4*LV + LTEST$
 If $LTEST = 2$, $WKDAY = WKDAY + 1$
 $= 1$, $WKDAY = WKDAY + 2$
 $= 0$, $WKDAY = WKDAY + 3$
 Otherwise $WKDAY = WKDAY - 3*(LV - 4)$
 If $WKDAY < 0$, $WKDAY = WKDAY + 7$
 If $WKDAY > 7$, $WKDAY = WKDAY - 7$

An alternate calculation

An alternate calculation sequence for WKDAY has been suggested*

***** ALL INTEGER ARITHMETIC *****

```

1  MDAY=30*(MO-1)+(MO-2)*58/100-1
   IF (MO.LE.2) MDAY=MDAY+MO

2  NIVC=IYR-(IYR/400)*400
   NLYR=NIVC/4
   NCEN=NIVC/100
   NIC=NIVC-100*NCEN

3  IY=6-2*NLYR

4  MD=NIVC-NLYR*4
   IF (MD.GE.1) IY=IY+1+MD
   IY=IY-NCEN
   IF (NIC.EQ.0.AND.NIVC.GT.0) IY=IY+1

5  IDAYR=MDAY+IDA

6  IF (NIC.EQ.0.AND.NCEN.GE.1) GO TO 7
   IF (MD.EQ.0.AND.MO.GT.2) IDAYR=IDAYR+1

7  JWK=IDAYR+IY
   NDX=JWK-(JWK/7)*7
   IF (NDX.LE.0) NDX=NDX+7

```

* This was contributed by A. W. Courtney, Scientific Programming, Box 508, Bloomfield Hills, Michigan 48013.

8 WKDAY=NDX

NOTE: IDA FORMERLY CALLED "DAY"
IYR FORMERLY CALLED "YR"
IDAYR = NUMBER OF THE DAY OF THE YEAR
∅ = NUMERICAL ZERO

HOLIDAY

An Algorithm to Identify the National Holidays of the United States of America

Simple modifications allow the identification of any holidays or any special days in any country as long as the Gregorian Calendar system is employed.

Data:

YR: Year AD

MO: Month

DAY: Day of the month

The primary variable calculated in this subroutine is HOL, the holiday indicator; it is 1 if the date is a holiday and zero if it is a non-holiday.

Calculation Sequence:

HOL = 1

If MO = 1 and DAY = 1

MO = 12, DAY = 31 and WKDAY = 6

MO = 1, DAY = 2 and WKDAY = 2

MO = 2, 22 > DAY ≥ 15 and WKDAY = 2

MO = 5, DAY ≥ 25 and WKDAY = 2

MO = 7 and DAY = 4

MO = 7, DAY = 3 and WKDAY = 6

MO = 7, DAY = 5 and WKDAY = 2

MO = 9, 7 > DAY and WKDAY = 2

MO = 10, 15 > DAY ≥ 8 and WKDAY = 2

MO = 10, 29 > DAY ≥ 22 and WKDAY = 2

MO = 11, 29 > DAY > 21 and WKDAY = 5

MO = 12, DAY = 24 and WKDAY = 6

MO = 12, DAY = 26 and WKDAY = 2

otherwise HOL = 0

PSY*

Various Algorithms for Approximate Psychrometric Calculations

The following symbols are used throughout the PSY subroutines:

- DB: Dry-bulb temperature, F (determined in CLIMATE)
- DP: Dewpoint temperature, F (determined in CLIMATE)
- WB: Wet-bulb temperature, F (determined in CLIMATE)
- t: Temperature, either DB, WB, or DP, F
- PB: Barometric pressure, in. Hg (determined in CLIMATE)
- H: Enthalpy of moist air, Btu per lb of dry air
- HS: Enthalpy of moist air saturated with water vapor,
Btu per lb of dry air
- PV: Partial pressure of water vapor in moist air, in. Hg
- PVS: Partial pressure of water vapor in moisture saturated
air, in. Hg
- V: Volume of moist air, cu ft per lb of dry air
- W: Humidity ratio of moist air, lb of water vapor per
lb dry air
- $\log(x)$: Natural logarithm of x
- $\log_{10}(x)$: Common logarithm of x

* When the exact Goff-Gratch method is required, algorithms described in Reference 17 should be used. Tables A-19 and A-20 taken from that reference list that the psychrometric properties calculated by the PSY routines and the exact Goff-Gratch method, respectively. From examination of these tables it can be seen that the values calculated by the PSY subroutines are in very good agreement with the values calculated by the exact Goff-Gratch method.

The following algorithms are used for calculating the psychrometric properties of moist air. All of these are not required for load calculations but are presented here in a package and can be applied in a variety of engineering applications.

a. PVS (t)

- | | | |
|--------|--------------------|------------------|
| 1. Let | A(1) = -7.90298 | B(1) = -9.09718 |
| | A(2) = 5.02808 | B(2) = -3.56654 |
| | A(3) = -1.3816 E-7 | B(3) = 0.876793 |
| | A(4) = 11.344 | B(4) = 0.0060273 |
| | A(5) = 8.1328 E-3 | |
| | A(6) = -3.49149 | |

2. Let $T = (t + 459.688)/1.8$
if T is less than 273.16, go to 3

Otherwise

Let $z = 373.16/T$

$$P1 = A(1) * (z-1)$$

$$P2 = A(2) * \log_{10}(z)$$

$$P3 = A(3) * (10^{A(4) * (1-1/z)} - 1)$$

$$P4 = A(5) * (10^{A(6) * (z-1)} - 1)$$

Go to 4.

3. Let $z = 273.16/T$
- | | |
|--|-----------------------------------|
| | P1 = B(1) * (z-1) |
| | P2 = B(2) * log ₁₀ (z) |
| | P3 = B(3) * (1-1/z) |
| | P4 = log ₁₀ (B(4)) |

4. $PVS = 29.921 * (10^{(P1 + P2 + P3 + P4)})$

b. PV (DB, WB, PB)

1. $PVP = PVS (WB)$
 $WS = 0.622 * PVP / (PB - PVP)$
IF $(WB \leq 32)$ go to 3
 $HL = 1093.049 + 0.441 * DB - WB$
 $CH = 0.24 + 0.441 * WS$
 $WH = WS - CH * (DB - WB) / HL$

2. $PV = PB * WH / (0.622 + WH)$

3. $PV = PVP - 5.704 * 10^{-4} * PB * (DB - WB) / 1.8$

c. W (DB, WB, PB)

1. $VP = PV (DB, WB, PB)$

2. $W = 0.622 + VP / (PB - VP)$

d. H (DB, WB, PB)

$H = 0.24 * DB + (1061 + 0.444 * DB) * W (DB, WB, PB)$

e. V (DB, WB, PB)

1. $WV = W (DB, WB, PB)$

2. $V = 0.754 * (DB + 459.7) * (1 + 7000 * WV / 4360) / PB$

f. H (DB, DP, PB)

1. $W = 0.622 * PVS (DP) / (PB - PVS (DP))$

2. $H = 0.24 * DB + (1061 + 0.444 * DB) * W$

g. WB (H, PB)

1. If $PB = 29.92$ and $H > 0$

Let $Y = \log(H)$

For $H < 11.758$

$$WB = 0.6040 + 3.4841 * Y + 1.3601 * (Y**2) + 0.9731 * (Y**3)$$

For H > 11.758

$$WB = 30.9185 - 39.682 * Y + 20.5841 * (Y**2) - 1.758 * (Y**3)$$

If $PB \neq 29.92$, or $H \leq 0$ solve the following equation by iterating WB

$$H = 0.24 * WB + (1061 + 0.444 * WB) * W(WB, WB, PB)$$

h. DP (PV)

1. Let $Y = \text{Log}(PV)$

If PV is less than 0.18036

$$DP = 71.98 + 24.873 * Y + 0.8927 * (Y**2)$$

Otherwise

$$DP = 79.047 + 20.579 * Y + 1.8893 * (Y**2)$$

Attached to this section are the Fortran listings of subroutines developed at the National Bureau of Standards which incorporate the psychrometric algorithms described above.

PVSF(X) corresponds to PVS (t)

DPF(PV) corresponds to DP (PV)

WBSF(H,PB) corresponds to WB (H, PB)

The routine entitled PSY1 generates dewpoint temperature, vapor pressure, humidity ratio, enthalpy, specific volume, and relative humidity when the dry-bulb temperature, wet-bulb temperature and the barometric pressure are provided as input. This subroutine essentially combines all the algorithms described in this section. PSY2 is similar to PSY1 except that the dewpoint temperature is given in lieu of the wet-bulb temperature.

SUBROUTINE PSY1(DB,WB,PB,DP,PV,W,H,V,RH)
 THIS SUBROUTINE CALCULATES VAPOR PRESSURE(PV), HUMIDITY RATIO (W)
 ENTHALPY(H), VOLUME(V), RELATIVE HUMIDITY(RH) AND DEW-POINT
 TEMPERATURE WHEN THE DRY-BULB TEMPERATURE(DB), WET-BULB TEMPERATUR
 (WB) AND BAROMETRIC PRESSURE(PB) ARE GIVEN

```

PVP=PVSF(WB)
IF(DB-WB)4,4,5
5 WSTAR=0.622*PVP/(PB-PVP)
IF(WB-32.)1,1,2
1 PV=PVP-5.704E-4*PB*(DB-WB)/1.8
GO TO 3
4 PV=PVP
GO TO 3
2 CDB=(DB-32.)/1.8
CWB=(WB-32.)/1.8
HL=597.31+0.4409*CDB-CWB
CH=0.2402+0.4409*WSTAR
EX=(WSTAR-CH*(CDB-CWB)/HL)/0.622
PV=PB*EX/(1.+EX)
3 W=0.622*PV/(PB-PV)
V=0.754*(DB+459.7)*(1+7000*W/4360)/PB
H=0.24*DB+(1061+0.444*DB)*W
DP=DPF(PV)
RH=PV/PVSF(DB)
RETURN
END

```

SUBROUTINE PSY2(DB,DP,PB,WB,PV,W,H,V,RH)
 THIS SUBROUTINE CALCULATES THE FOLLOWINGS WHEN DRY-BULB TEMPERATURE
 (DB), DEW-POINT TEMPERATURE(DP), AND BAROMETRIC PRESSURE(PB) ARE GIVEN

```

WB WET-BULB TEMPERATURE
W HUMIDITY RATIO
H ENTHALPY
V VOLUME
PV VAPOR PRESSURE
RH RELATIVE HUMIDITY
PV=PVSF(DP)
PVS=PVSF(DB)
RH=PV/PVS
W=0.622*PV/(PB-PV)
V=0.754*(DB+459.7)*(1+7000*W/4360)/PB
H=0.24*DB+(1061+0.444*DB)*W
WB=WBF(H,PB)
RETURN
END

```

FUNCTION WBF(H,PB)
 THIS PROGRAM APPROXIMATES THE WET-BULB TEMPERATURE WHEN
 ENTHALPY AND BAROMETRIC PRESSURE ARE GIVEN

```

    IF(PB,NE,29.92) GO TO 2
    Y=LOG(H)
    IF(H,GT,11.758) GO TO 3
    WBF=0.6041+3.4841*Y+1.3601*Y*Y+0.97307*Y*Y*Y
    GO TO 4
  3 WBF=30.9185-39.68200*Y+20.5841*Y*Y-1.758*Y*Y*Y
    GO TO 4
  2 WB1=150.
    PV1=PVSF(WB1)
    W1=0.622*PV1/(PB-PV1)
    X1=0.24*WB1+(1061+0.444*WB1)*W1
    Y1=H-X1
  9 WB2=WB1-1
    PV2=PVSF(WB2)
    W2=0.622*PV2/(PB-PV2)
    X2=0.24*WB2+(1061+0.444*WB2)*W2
    Y2=H-X2
    IF(Y1*Y2) 6,7,8
  8 WB1=WB2
    Y1=Y2
    GO TO 9
  7 IF(Y1) 10,11,10
  11 WBF=WB1
    GO TO 4
  10 WBF=WB2
    GO TO 4
  6 Z=ABS(Y1/Y2)
    WBF=(WB2*Z+WB1)/(1+Z)
  4 RETURN
  END

```

FUNCTION DPF(PV)
 THIS SUBROUTINE CALCULATES DEW-POINT TEMPERATURE FOR GIVEN VAPOR PRESSURE

```

  Y=LOG(PV)
  IF(PV,GT,0.1836) GO TO 1
  DPF=71.98+24.873*Y+0.8927*Y*Y
  GO TO 2
  1 DPF=79.047+30.579*Y+1.8893*Y*Y
  2 RETURN
  END

```

```

FUNCTION PVSF(X)
DIMENSION A(6)/-7.90298,5.02808,-1.3816E-7,11.344,8.1328E-3,-3.491
149/,B(4)/-9.09718,-3.56654,0.876793,0.0060273/,P(4)
T=(X+459.688)/1.8
IF(T.LT.273.16) GO TO 3
Z=373.16/T
P(1)=A(1)*(Z-1)
P(2)=A(2)*LOG10(Z)
Z1=A(4)*(1-1/Z)
P(3)=A(3)*(10**Z1-1)
Z1=A(6)*(Z-1)
P(4)=A(5)*(10**Z1-1)
GO TO 4
3 Z=273.16/T
P(1)=B(1)*(Z-1)
P(2)=B(2)*LOG10(Z)
P(3)=B(3)*(1-1/Z)
P(4)=LOG10(B(4))
4 SUM=0
DO 5 I=1,4
5 SUM=SUM+P(I)
PVSF=29.921*10**SUM
RETURN
END

```

Table A-19

PB = 29.92 in. Hg.

| DB | WB | DP | RH (%) | PV | W | H | V |
|------|------|-------|-----------|--------|--------|-------|-------|
| 80.0 | 80.0 | 80.0 | 100.0 | 1.0323 | .02223 | 43.57 | 14.09 |
| 80.0 | 79.0 | 78.7 | 95.7 | .9883 | .02125 | 42.50 | 14.06 |
| 80.0 | 78.0 | 77.3 | 91.6 | .9453 | .02029 | 41.45 | 14.04 |
| 80.0 | 77.0 | 76.0 | 87.5 | .9031 | .01936 | 40.43 | 14.02 |
| 80.0 | 76.0 | 74.5 | 83.5 | .8619 | .01845 | 39.43 | 14.00 |
| 80.0 | 75.0 | 73.1 | 79.6 | .8215 | .01756 | 38.45 | 13.98 |
| 80.0 | 74.0 | 71.6 | 75.8 | .7820 | .01669 | 37.50 | 13.97 |
| 80.0 | 73.0 | 70.1 | 72.0 | .7433 | .01584 | 36.57 | 13.95 |
| 80.0 | 72.0 | 68.6 | 68.3 | .7054 | .01502 | 35.67 | 13.93 |
| 80.0 | 71.0 | 67.0 | 64.7 | .6682 | .01421 | 34.78 | 13.91 |
| 80.0 | 70.0 | 65.4 | 61.2 | .6319 | .01342 | 33.92 | 13.89 |
| 80.0 | 69.0 | 63.7 | 57.8 | .5963 | .01265 | 33.07 | 13.88 |
| 80.0 | 68.0 | 62.0 | 54.4 | .5615 | .01190 | 32.24 | 13.86 |
| 80.0 | 67.0 | 60.3 | 51.1 | .5273 | .01116 | 31.44 | 13.84 |
| 80.0 | 66.0 | 58.4 | 47.8 | .4939 | .01044 | 30.65 | 13.83 |
| 80.0 | 65.0 | 56.5 | 44.7 | .4611 | .00974 | 29.88 | 13.81 |
| 80.0 | 64.0 | 54.5 | 41.6 | .4290 | .00905 | 29.12 | 13.80 |
| 80.0 | 63.0 | 52.5 | 38.5 | .3976 | .00838 | 28.39 | 13.78 |
| 80.0 | 62.0 | 50.3 | 35.5 | .3668 | .00772 | 27.66 | 13.77 |
| 80.0 | 61.0 | 48.0 | 32.6 | .3366 | .00708 | 26.96 | 13.76 |
| 80.0 | 60.0 | 45.6 | 29.7 | .3070 | .00645 | 26.27 | 13.74 |
| 80.0 | 59.0 | 43.0 | 26.9 | .2780 | .00583 | 25.60 | 13.73 |
| 80.0 | 58.0 | 40.2 | 24.2 | .2495 | .00523 | 24.94 | 13.71 |
| 80.0 | 57.0 | 37.3 | 21.5 | .2216 | .00464 | 24.29 | 13.70 |
| 80.0 | 56.0 | 34.0 | 18.8 | .1943 | .00407 | 23.66 | 13.69 |
| 80.0 | 55.0 | 30.4 | 16.2 | .1675 | .00350 | 23.04 | 13.68 |
| 80.0 | 54.0 | 26.7 | 13.7 | .1412 | .00295 | 22.43 | 13.67 |
| 80.0 | 53.0 | 22.4 | 11.2 | .1154 | .00241 | 21.84 | 13.65 |
| 80.0 | 52.0 | 17.3 | 8.7 | .0900 | .00188 | 21.26 | 13.64 |
| 80.0 | 51.0 | 10.7 | 6.3 | .0652 | .00136 | 20.69 | 13.63 |
| 80.0 | 50.0 | 1.6 | 4.0 | .0408 | .00085 | 20.13 | 13.62 |
| 80.0 | 49.0 | -14.6 | 1.6 | .0169 | .00035 | 19.59 | 13.61 |

Table A-20

Moist Air Properties Calculated by the
Exact Goff-Gratch Method

PB = 29.92 in. Hg

| DB | WB | DP | RH (%) | PV | W | H | S | V |
|------|------|------|-----------|--------|--------|-------|-------|-------|
| 80.0 | 80.0 | 80.0 | 100.0 | 1.0323 | .02233 | 43.69 | .0864 | 14.09 |
| 80.0 | 79.0 | 78.7 | 95.7 | .9883 | .02135 | 42.61 | .0843 | 14.07 |
| 80.0 | 78.0 | 77.3 | 91.6 | .9453 | .02039 | 41.56 | .0822 | 14.05 |
| 80.0 | 77.0 | 76.0 | 87.5 | .9032 | .01945 | 40.53 | .0802 | 14.03 |
| 80.0 | 76.0 | 74.6 | 83.5 | .8620 | .01854 | 39.53 | .0783 | 14.01 |
| 80.0 | 75.0 | 73.1 | 79.6 | .8217 | .01764 | 38.55 | .0764 | 13.99 |
| 80.0 | 74.0 | 71.7 | 75.8 | .7822 | .01677 | 37.60 | .0745 | 13.97 |
| 80.0 | 73.0 | 70.2 | 72.0 | .7435 | .01592 | 36.67 | .0727 | 13.95 |
| 80.0 | 72.0 | 68.6 | 68.4 | .7057 | .01509 | 35.76 | .0709 | 13.93 |
| 80.0 | 71.0 | 67.1 | 64.8 | .6686 | .01428 | 34.87 | .0692 | 13.91 |
| 80.0 | 70.0 | 65.5 | 61.2 | .6323 | .01349 | 34.00 | .0675 | 13.90 |
| 80.0 | 69.0 | 63.8 | 57.8 | .5967 | .01271 | 33.15 | .0658 | 13.88 |
| 80.0 | 68.0 | 62.1 | 54.4 | .5619 | .01196 | 32.32 | .0642 | 13.86 |
| 80.0 | 67.0 | 60.3 | 51.1 | .5278 | .01122 | 31.51 | .0626 | 13.85 |
| 80.0 | 66.0 | 58.5 | 47.9 | .4944 | .01050 | 30.72 | .0610 | 13.83 |
| 80.0 | 65.0 | 56.6 | 44.7 | .4617 | .00979 | 29.95 | .0595 | 13.81 |
| 80.0 | 64.0 | 54.6 | 41.6 | .4296 | .00910 | 29.19 | .0581 | 13.80 |
| 80.0 | 63.0 | 52.5 | 38.6 | .3982 | .00843 | 28.45 | .0566 | 13.78 |
| 80.0 | 62.0 | 50.4 | 35.6 | .3674 | .00777 | 27.73 | .0552 | 13.77 |
| 80.0 | 61.0 | 48.1 | 32.7 | .3372 | .00712 | 27.02 | .0538 | 13.76 |
| 80.0 | 60.0 | 45.6 | 29.8 | .3077 | .00649 | 26.33 | .0525 | 13.74 |
| 80.0 | 59.0 | 43.1 | 27.0 | .2787 | .00587 | 25.66 | .0511 | 13.73 |
| 80.0 | 58.0 | 40.3 | 24.2 | .2503 | .00527 | 24.99 | .0498 | 13.72 |
| 80.0 | 57.0 | 37.3 | 21.5 | .2224 | .00468 | 24.35 | .0486 | 13.70 |
| 80.0 | 56.0 | 34.0 | 18.9 | .1951 | .00410 | 23.71 | .0473 | 13.69 |
| 80.0 | 55.0 | 30.5 | 16.3 | .1683 | .00353 | 23.09 | .0461 | 13.68 |
| 80.0 | 54.0 | 26.8 | 13.8 | .1420 | .00293 | 22.49 | .0449 | 13.67 |
| 80.0 | 53.0 | 22.6 | 11.3 | .1162 | .00244 | 21.89 | .0438 | 13.65 |
| 80.0 | 52.0 | 17.5 | 8.8 | .0910 | .00191 | 21.31 | .0426 | 13.64 |
| 80.0 | 51.0 | 11.0 | 6.4 | .0662 | .00138 | 20.74 | .0415 | 13.63 |
| 80.0 | 50.0 | 2.0 | 4.1 | .0418 | .00087 | 20.18 | .0404 | 13.62 |

References

1. Kimura, K., and Stephenson, D. G., "Solar Radiation on Cloudy Days", ASHRAE Transaction, pp. 227-233, Part I, 1969.
2. Mitalas, G. P., and Stephenson, D. G., "Absorption and Transmission of Thermal Radiation by Single and Double Glazed Windows", National Research Council of Canada Report 7104, December 1962.
3. Stephenson, D. G., "Tables of Solar Altitude, Azimuth, Intensity, and Heat Gain Factors for Latitudes from 43 to 55 Degrees North", National Research Council of Canada, Division of Building Research, Technical Paper No. 243, April 1967.
4. Groth, C. C., and Lokmanhekim, M., "Shadow - A New Technique for the Calculation of Shadow Shapes and Areas by Digital Computer", Second Hawaii International Conference on System Sciences, Honolulu, Hawaii, January 22-24, 1969.
5. Sun, Tseng-Yao, "Shadow Area Equations for Window Overhangs and Side Fins and Their Application in Computer Calculation", ASHRAE Semiannual meeting, Columbus, Ohio, February 5-8, 1968, Paper No. 2059.
6. Ito, N., and Kimura, K., "Convection Heat Transfer Coefficient at the Exterior Surface of Buildings Exposed to Natural Wind", (Japanese), Transaction of Japanese Society of Architectural Engineering, 1968.
7. Robinson, H. E. and F. J. Powell, "Thermal Resistance of Air Spaces and Fibrous Insulation Bounded by Reflective Surfaces", Building Material and Structures Report 151, National Bureau of Standards, 1957.

8. Stephenson, D. G., and Mitalas, G. P., "Calculation of Heat Conduction Transfer Functions for Multi-Layer Slabs", ASHRAE Transactions, Vol. 77, Part II, 1971.
9. Carslaw, H. S., and Jaeger, J. C., Conduction of Heat in Solids, Second Edition, 1959, page 326, Oxford at the Clarendon Press.
10. Mitalas, G. P. and J. G. Arseneault, "Fortran IV Program to Calculate Heat Flux Response Factors for Multi-layer Slabs, DBR Computer Program No. 23, National Research Council of Canada, 1967.
11. Kusuda, T., "Thermal Response Factors for Multi-layer Structures of Various Heat Conduction Systems", ASHRAE Transactions, pp. 250-269, Part I, 1969.
12. Hoglund, B. I., Mitalas, G. P., and Stephenson, D. G., "Surface Temperatures and Heat Fluxes for Flat Roofs", Journal of Building Science, Vol. 2, No. 1, pp. 29-36, January 1967.
13. Stephenson, D. G. and Mitalas, G. P., "Cooling Load Calculations by Thermal Response Factor Method", ASHRAE Semiannual Meeting, Detroit, Michigan, January 20 - February 2, 1967, Paper No. 2018.
14. Mitalas, G. P. and Stephenson, D. G., "Room Thermal Response Factors", ASHRAE Transactions, P III 2.1 - 2.10, Part I, 1967.
15. Tamura, G., "Computer Analysis of Smoke Control with Building Air Handling Systems", ASHRAE Journal, pp. 46-54, August 1972.
16. Bailey, A., and Vincent, N. D. G., "Wind-Pressure on Buildings Including Effects of Adjacent Buildings", Journal, Institute of Civil Engineers, Vol. 20, No. 8, October, 1943.

17. Kusuda, T., "Algorithms for Psychrometric Calculations", Building Science Series 21, National Bureau of Standards, January 1970.
18. Tamura, G. T. and Wilson, A. G., "Building Pressures Caused by Chimney Action and Mechanical Ventilation", ASHRAE 74th Annual Meeting, Minneapolis, Minnesota, June 26-28, 1967, Paper No. 2047.
19. Brown, G., "Heat Transfer at Exterior Surfaces of Buildings", (Swedish), Transactions of National Swedish Coun. Building Res., Stockholm 27, 1956.
20. Brown, K. M., and Conte, S. D., "The Solution of Simultaneous Non-linear Equations", Proceedings of 22nd National Conference, Association for Computing Machinery, pp. 111-114, 1967.
21. Haurwitz, B., "Insolation in Relation to Cloudiness and Cloud Density", Journal of Meteorology, Vol. 9, No. 4, September 1946.
22. Kimura, K. and Stephenson, D. G., "Theoretical Study of Cooling Load Caused by Lights", ASHRAE Annual Meeting, Lake Placid, New York, June 24-26, 1968, Paper No. 2087.
23. Mitalas, G. P., "An Experimental Check on the Weighting Factor Method of Calculating Room Cooling Load", ASHRAE Transactions, 1969.
24. Mitalas, G. P., "Calculation of Transient Heat Flow Through Walls and Roofs", ASHRAE Annual Meeting, Lake Placid, New York, June 24-26, 1968, Paper No. 2086.
25. Sun, Tseng-Yao, "Computer Evaluation of the Shadow Area on a Window Cast by the Adjacent Building", prepared for submission as a paper in the future.
26. Threlkeld, J. L., "Thermal Environmental Engineering", Prentice Hall, 1970.

8. Appendix B

Weighting Factor Method of Calculating
Heating and Cooling Loads and Space Temperature^{*/}

^{*/} This section was prepared by D. G. Stephenson and G. Mitalas of the National Research Council of Canada for the ASHRAE Task Group on Energy Requirements for Heating and Cooling.

The weighting factor method is based on the assumption that the heat transfer processes occurring in a room can be described by linear equations; and thus that the superposition principle can be used for the calculation of cooling load and space temperature. This means that the relationship between any excitation (e.g., power input to lights) and the corresponding component of the cooling load can be expressed in the form of a characteristic transfer function. Once all the transfer functions have been determined for a room, they can be used to calculate the response to any excitation. The weighting factors are a convenient way of representing these characteristic transfer functions for a room: they relate the Z-transforms of the excitations to the Z-transforms of the corresponding cooling load components.

The Z-transform^{1, 2/}

When a continuous signal, $f(t)$, is sampled at regular intervals of Δ , the output of the sampling device is a train of pulses as shown in Figure B1. The Laplace transform of this output signal is

$$f(0) + f(\Delta)e^{-s\Delta} + f(2\Delta)e^{-2s\Delta} + \dots \quad (1)$$

If Z is substituted for $e^{s\Delta}$, the transform of the output from the sampler is

$$f(0) + f(\Delta)Z^{-1} + f(2\Delta)Z^{-2} + \dots \quad (2)$$

This polynomial in Z^{-1} is the Z-transform of the function $f(t)$. The chief advantage of this type of transform is that it can be obtained just by sampling the function at regular intervals: the successive outputs being the coefficients of successive powers of Z^{-1} in the Z-transform.

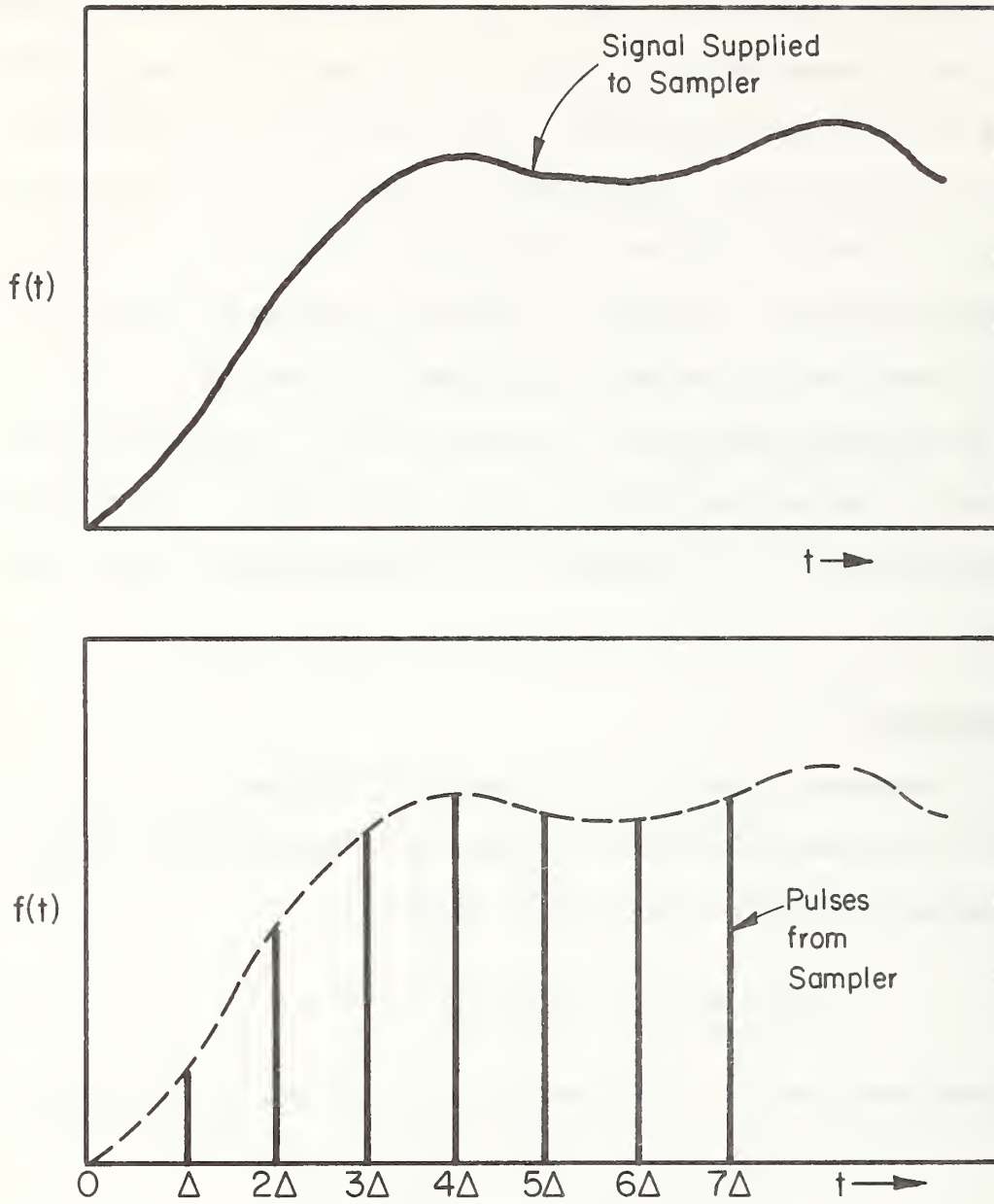

Figure B-1 Pulse Representation of a Continuous Function

If both the input and output of a system are expressed in terms of their Z-transforms, the ratio of the output/input is a Z-transfer function for the system. Assuming that such a transfer function, $K(Z)$, can be found, and that it can be expressed as the ratio of two polynomials in Z^{-1}

$$\text{i.e.,} \quad K(Z) = \frac{a_0 + a_1 Z^{-1} + a_2 Z^{-2} + \dots}{b_0 + b_1 Z^{-1} + b_2 Z^{-2} + \dots} \quad (3)$$

it follows that $O(Z)$, the Z-transform of the output that results from an input represented by $I(Z)$ is

$$O(Z) = K(Z) \cdot I(Z) \quad (4)$$

Both sides of this equation are polynomials so the coefficients of the various powers of Z^{-1} must be the same on the two sides of the equation. Thus, equating the coefficients of Z^{-n} gives

$$O_n \cdot b_0 = I_n \cdot a_0 + I_{n-1} \cdot a_1 + I_{n-2} \cdot a_2 + \dots - \{O_{n-1} \cdot b_1 + O_{n-2} \cdot b_2 + \dots\} \quad (5)$$

where the subscript n on O and I indicates the value of the function at $t = n\Delta$, i.e., O_n is the coefficient of Z^{-n} in the Z-transform $O(Z)$. This expression relates the output at any time $t = n\Delta$ to the input at that time and the values of the input and output at earlier times. The coefficients a_0, a_1, \dots and b_0, b_1, \dots , contain all the characteristics of the system.

Cooling Load, Heat Extraction and Room Temperature

Using the Z-transfer functions approach, the cooling load is the output that results from the input, which is the heat gain. The weighting factor sets are the transfer functions relating the cooling loads to heat gains. The procedure for calculating cooling load is, therefore, first to calculate the various components of the heat gain, and then to combine them with the appropriate weighting factor sets to obtain the cooling load. An expression like equation (5) is used to compute each component of the cooling load.

The cooling load of a space depends on both the magnitude and the nature of its excitations (i.e., outside air temperature, direct and diffuse solar radiation, electric energy input to lights, etc.). The resulting cooling load also depends on the location of the element that absorbs the energy of the excitation. For example, the cooling load profile resulting from one unit of solar radiation absorbed by the window glass is quite different from that of one unit of solar radiation absorbed by the floor surface. To shorten the computation of cooling load, the heat gain must be subdivided into a limited number of components. For example, the total heat gain by a space can be represented by the following components:

- (1) Heat gain through window. (HEATG and HEATG¹)
- (2) Heat gain through exterior walls and roofs. (HEATX)
- (3) Total power input to lights. (HEATIS)
- (4) Heat gain through doors, partitions, underground walls and floors, and due to internal heat sources other than lights. (HEATDP)
- (5) Sensible heat gain due to infiltration. (HEATVS)

Each of these heat gain components is calculated on the basis of a constant air temperature in the space. The actual air temperature generally deviates from this reference value, and consequently the rate of heat extraction from the space, HE, differs from the cooling load. The calculation of actual room air temperature and heat extraction rate is the final step in the sequence of calculation: in this case, the previously calculated cooling load is the input along with the characteristics of the air conditioning unit; and heat extraction rate and air temperature are the outputs. If this transfer function is expressed in the form

$$\frac{HE - CL}{\delta} = \sum_0^v x_j z^{-j} / 1 + \sum_1^w y_j z^{-j},$$

or

$$HE_n = CL_n + \sum_0^v x_j * \delta_{n-j} - \sum_1^w y_j * (HE_{n-j} - CL_{n-j}) \quad (6)$$

where δ is the deviation of actual air temperature from the reference value used to calculate the heat gains.

The heat extraction rate given by equation (6) must match the rate given by the characteristic of the air conditioning unit. For example, a cooling unit with a simple proportional control system has a characteristic of the form

$$HE_n = C + D * \delta_n \quad (7)$$

where

C = heat extraction rate of the unit operating in a room
at the reference temperature

D = change in the rate of heat extraction caused by one degree rise in room air temperature

Equations (6) and (7) can be combined to give an explicit expression for δ_n

$$\delta_n = \frac{CL_n - C + \sum_1^v x_j * \delta_{n-j} - \sum_1^w y_j * (HE_{n-j} - CL_{n-j})}{D - x_0} \quad (8)$$

and then equation (7) can be used to evaluate HE_n .

Equation (8) can be used to calculate δ_n even if the cooling equipment is off: when the equipment is not operating, C and D are both zero.

Calculation of Room Weighting Factors

The calculation of the room weighting factors is based on the solution of a set of heat balance equations for all the room air^{3, 4/} (RMTMP). A computer program for evaluating weighting factors has been developed by the National Research Council of Canada^{5/}, based on the procedure given in Reference 4.

Three different groups of room weighting factor sets are computed by this program:

- (1) The first group is very large, consisting of a set of factors for each excitation at each surface.
- (2) The second group combines all of the sets in group 1 that pertain to diffuse solar radiation into a single set; it combines all of the sets for direct solar radiation incident on the room surfaces other than inside window pane, floor, and furniture into another combined set; and lastly, it combines all the sets that

pertain to excitation by the power supplied to the lights into a single set.

- (3) The third group of factors carry the consolidation of the various sets of the limit: there is just one set of factors for each component of heat gain.

It is not intended that the first group should be used directly for room cooling or heating load calculations, as the second group give essentially the same results with considerably less computation^{6/}. The further simplification provided by the use of the third group require that the following assumptions be made:

- (1) That the heat gain through room envelope components can be calculated with sufficient accuracy using combined inside surface heat transfer coefficient and that the room weighting factors are the same for heat gain through window, opaque outside wall, corridor wall and a roof.
- (2) That the fraction of the solar radiation absorbed by the window glass and shade, and transmitted directly into the room as well as the portions absorbed by various room surfaces and furniture are constant during the day.

It is probable that the first assumption will not introduce significant errors; however, the second assumption is questionable. At this time, research information is lacking to establish the possible magnitude of the error introduced by this assumption.

The procedures given in this report to convert room excitation to cooling load and heat extraction are based on the third group of room weighting factors, i.e., RMRG, RMRX, RMRT and RMRTS. In addition, simplified procedures are given for the calculation of the RMRT and RMRTS sets. If the highest possible precision is important, weighting factors in the second group should be used.

References

- (1) T. R. Ragazzini and G. F. Franklin, "Sampled-Data Control Systems", McGraw-Hill Book Company, Inc., 1958.
- (2) E. I. Jury, "Theory and Application of the Z-transform Method", Wiley, 1964.
- (3) D. G. Stephenson and G. P. Mitalas, "Cooling Load Calculations by Thermal Response Factor Method", ASHRAE Transactions, Vol. 73, Part 1, 1967.
- (4) G. P. Mitalas and D. G. Stephenson, "Room Thermal Response Factors", ASHRAE Transactions, Vol. 33, Part 1, 1967.
- (5) G. P. Mitalas and J. G. Arseneault, "Fortran IV Program to Calculate Weighting Factors for a Room".
- (6) G. P. Mitalas, "An Experimental Check on the Weighting Factor Method of Calculating Room Cooling Load", presented at ASHRAE Denver Meeting, 1969.
- (7) G. P. Mitalas, "Calculations of Transient Heat Flow Through Walls and Roofs, ASHRAE Transactions, Vol. 74, Part II, 1968.

- (8) D. G. Stephenson and G. P. Mitalas, "Transient Heat Conduction Through Walls and Roofs, prepared for submission to the International Journal of Heat and Mass Transfer.
- (9) T. Kusuda, "Thermal Response Factors for Multi-layer Structures of Various Heat Conduction Systems, presented at ASHRAE Chicago Meeting, 1969.
- (10) G. P. Mitalas and J. G. Arseneault, "Fortran IV Program to Calculate Heat Flux Response Factors for Multi-Layer Slabs, DBR Computer Program No. 23, National Research Council of Canada, 1967.

9. Appendix C

NBSLD Data Forms

Introduction

This manual contains the input data forms with instructions for preparing data needed to perform heating and cooling load calculations using NBSLD.

In addition, the manual contains engineering data needed for the computations so that the use of other handbooks or references are generally unnecessary. The required numerical data are to be filled into blank spaces provided on each DATA SHEET and then each sheet can be used directly at a computer terminal or to produce a data card if the program is being run in "batch mode" at a central facility.

General Instruction

Figure C-1 shows the flow diagram or sequence for the data preparation.

Schedule Profile data sheets A, B, C and D are prepared for a building and are assumed the same for all zones or rooms within the building.

DATA SHEETS 1 through 3 are prepared for each different building, thus need not be repeated for the analysis of rooms within the same building.

DATA SHEETS 6 and 7 usually need to be prepared only for the first room of the building, because other rooms that follow in the same building usually employ the same wall, roof, and floor constructions.

When two rooms have identical shape and construction and differ only in orientation, the second room is considered to be rotated with respect to the first room and requires only DATA SHEETS 4 and 5.

DATA SHEET PREPARATION GUIDE

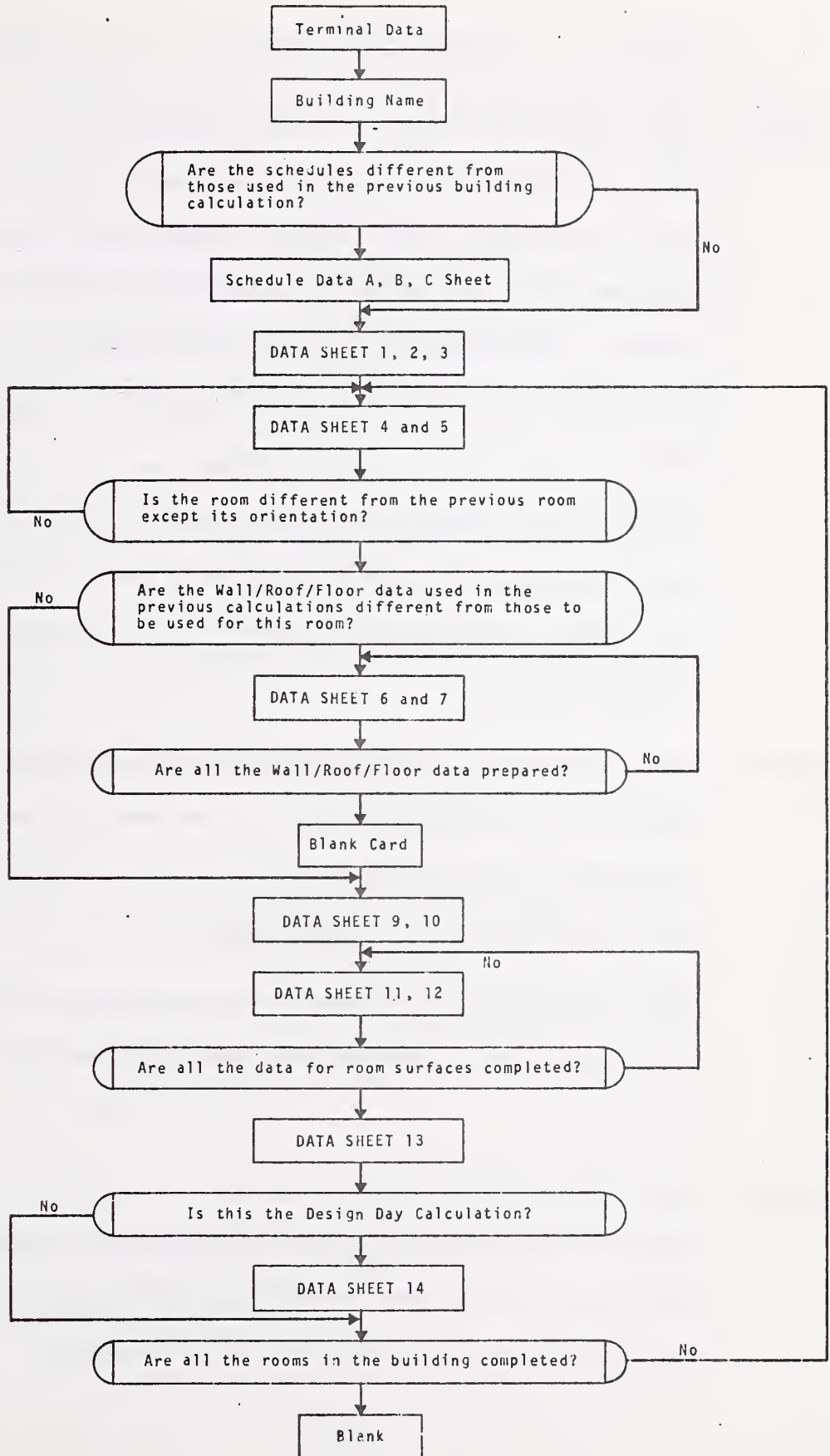

Operational Data

RUNID: Index for the calculation of Conduction Transfer Functions:

RUNID = 1 if the load calculation being made for this particular run requires the generation of Conduction Transfer Functions for the walls, roof, ceilings and floors in the building. The Conduction Transfer Functions generated during the run will be stored in tape unit 8 for the future rerun.

RUNID = 2 if the Conduction Transfer Functions have already been calculated and stored in tape unit 8 and this particular run does not require the generation of new Conduction Transfer Functions.

RUNTYP: Index for the types of calculations to be performed:

RUNTYP = 1 if the calculation is for the hour by hour determination of heating and cooling load for a specified period by making use of weather data tape (unit 7).

RUNTYP = 2 if the calculation is for the design heating and cooling load. A weather data tape is not required for this run.

ASHRAE: Index for the weighting factor usage:

ASHRAE = 0 if the Weighting Factor Method of the ASHRAE Task Group is replaced by a more exact calculation procedure developed at the National Bureau of Standards.

ASHRAE = 1 if the Weighting Factor Method of the ASHRAE Task Group is used to convert the heat gains and losses to loads.

IDETAL: Index for the output specification:

IDETAL = 0 if output of the run is only the daily maximum and the daily total heating and cooling loads.

IDETAL = 1, output of the run will display input data and details of intermediate results such as Conduction Transfer Functions, Radiation heat exchange factors, solar radiation and solar heat gain.

METHOD: Index for the treatment of room surface radiation heat exchange calculation:

METHOD = 0 if the radiation exchange among the room surfaces are treated individually on room by room basis.

METHOD = 1 if a building zone is treated as a box and all the interior partition walls and floor/ceiling sandwich constructions are treated as a single slab to be distributed uniformly on the floor of the box as an extra layer for that floor.

RFMTAP: Tape drive unit number for the tape to be used by the system simulation program of Ross F. Meriwether. If no tape is needed, RFMTAP = 0.

(integer variables)

| RUNID | RUNTYP | ASHRAE | IDETAL | METHOD | RFMTAP |
|-------|--------|--------|--------|--------|--------|
| | | | | | |

Building Name

NAMEBD

Identification of the job, name of the building, address or other pertinent information may be used within the limit of 34 alphabetical/numerical characters.

NAMEBD

| | | | | | | | | | | | | | | | | | | | | | | | | | | | | | | | | | | | | | | | | | | | | | | |
|---|---|---|---|---|---|---|---|---|----|----|----|----|----|----|----|----|----|----|----|----|----|----|----|----|----|----|----|----|----|----|----|----|----|----|----|----|----|----|----|----|----|--|--|--|--|--|
| 1 | 2 | 3 | 4 | 5 | 6 | 7 | 8 | 9 | 10 | 11 | 12 | 13 | 14 | 15 | 16 | 17 | 18 | 19 | 20 | 21 | 22 | 23 | 24 | 25 | 26 | 27 | 28 | 29 | 30 | 31 | 32 | 33 | 64 | 65 | 66 | 67 | 68 | 69 | 70 | 71 | 72 | | | | | |
| X | X | | | | | | | | | | | | | | | | | | | | | | | | | | | | | | | | | | | | | | | | | | | | | |

Start from Column 3

(Alphanumeric data)

Schedule Profile-A

QLITX: Normalized* daily schedule (24-hour profile) or power input for lighting during the weekdays.

QEQUX: Normalized* daily schedule (24-hour profile) of power input for electrical appliances and other equipment (other than those involved for heating/cooling equipment) during the weekdays.

QOCUP: Normalized* daily schedule (24-hour profile) of occupancy (number of adults) during the weekdays.

QLITX

| | | | | | | | | | |
|--|--|--|--|--|--|--|--|--|--|
| | | | | | | | | | |
| | | | | | | | | | |
| | | | | | | | | | |

QEQUX

| | | | | | | | | | |
|--|--|--|--|--|--|--|--|--|--|
| | | | | | | | | | |
| | | | | | | | | | |
| | | | | | | | | | |

* Having a value between 0 and 1.

QOCUP

| | | | | | | | | | |
|--|--|--|--|--|--|--|--|--|--|
| | | | | | | | | | |
| | | | | | | | | | |
| | | | | | | | | | |

Schedule Profile-B*

QLITX', QEQUX', QOCUP' are the same as QLITX, QEQUX and QOCUP respectively except that these data are for the weekends.

QLITX'

| | | | | | | | | | |
|--|--|--|--|--|--|--|--|--|--|
| | | | | | | | | | |
| | | | | | | | | | |
| | | | | | | | | | |

QEQUX'

| | | | | | | | | | |
|--|--|--|--|--|--|--|--|--|--|
| | | | | | | | | | |
| | | | | | | | | | |
| | | | | | | | | | |

QOCUP'

| | | | | | | | | | |
|--|--|--|--|--|--|--|--|--|--|
| | | | | | | | | | |
| | | | | | | | | | |
| | | | | | | | | | |

* These data should be all zero for the design day calculation.

Schedule Profile-C*

QLITX", QEQUX", QOCUP" are the same as QLITX, QEQUX, and QOCUP respectively except that these data are for the holidays.

QLITX"

| | | | | | | | | | |
|--|--|--|--|--|--|--|--|--|--|
| | | | | | | | | | |
| | | | | | | | | | |
| | | | | | | | | | |

QEQUX"

| | | | | | | | | | |
|--|--|--|--|--|--|--|--|--|--|
| | | | | | | | | | |
| | | | | | | | | | |
| | | | | | | | | | |

QOCUP"

| | | | | | | | | | |
|--|--|--|--|--|--|--|--|--|--|
| | | | | | | | | | |
| | | | | | | | | | |
| | | | | | | | | | |

* These data should be all zero for the design day calculations.

Schedule Profile-D

Room Temperature and Humidity Schedule

RMDBS: 24 hour profile of room thermostat setting during the occupied cooling day, °F.

RMDBW: 24 hour profile of room thermostat setting during the occupied heating day, °F.

RMDBWO: Constant room thermostat setting during the unoccupied heating day, °F.

RMDBSO: Constant room thermostat setting during the unoccupied cooling day, °F.

RHW: Constant room relative humidity setting during the occupied heating days, %.

RHS: Constant room relative humidity setting during the occupied cooling days, %.

RMDBS

| | | | | | | | | | |
|--|--|--|--|--|--|--|--|--|--|
| | | | | | | | | | |
| | | | | | | | | | |
| | | | | | | | | | |

RMDBW

| | | | | | | | | | |
|--|--|--|--|--|--|--|--|--|--|
| | | | | | | | | | |
| | | | | | | | | | |
| | | | | | | | | | |

| | | | | | | | | | |
|-------|--------|-----|-----|--|--|--|--|--|--|
| RMDBW | RMDBSO | RHW | RHS | | | | | | |
| | | | | | | | | | |

Data Sheet 1*

NDAY: Number of days for which the calculations are to be performed.

NSKIP: Number of days to be skipped in case the computation does not start from the first day of the weather tape, which is usually 00 hour, of January 1 if standard NCC 1440 tape is used.

TAPE 2: Tape unit or file number for the output tape, if 0 an output tape or file is not produced. The output tape or file contains the hourly load and weather data needed for the system simulation.

| | | | | | | | | | |
|------|-------|--------|--|--|--|--|--|--|--|
| NDAY | NSKIP | TAPE 2 | | | | | | | |
| | | | | | | | | | |

(integer data)

* For the design calculation or when RUNTYP is 2, all three variables listed here can be input as 0.

Data Sheet 2*

Month: Month for which the calculation is to be done.

Day: Day of the month on which the calculation is to be done.

ELAPS: Number of days elapsed from January 1 to reach the design day. For example, it is 201 for July 21 of a non-leap year.

DBMAX: Maximum outdoor temperature of the design day for cooling (see Table C1 which has been taken from the 1972 ASHRAE Handbook of Fundamentals).

RANGE: Daily range of the outdoor temperature during the design day, °F, (see Table C1).

WBMAX: Summer design wet-bulb temperature, °F, (see Table C1).

DBMWT: Design outdoor air temperature for the heating load calculation, °F, (see Table C1).

TGS: Summer design ground temperature, °F, (see Table C1).

TGW: Winter design ground temperature, °F, (see Table C1).

* If a weather tape is being used and a conventional design calculation is not being done, all variables listed here can be input as 0 except TGS, TGW and UG.

UG: Ground heat transfer coefficient for design heating load calculations based upon Chapter 21, 1972 ASHRAE Handbook of Fundamentals, Btuh*, (use 0.1 if uncertain).

| MONTH | DAY | ELAPS | DBMAX | RANGE | WBMAX | DBMWT | TGS | TGW | UG |
|-------|-----|-------|-------|-------|-------|-------|-----|-----|----|
| | | | | | | | | | |

* Btuh = Btu per (hr) (sq. ft.) (°F).

Data Sheet 3

LONG: Longitude of the building location, degrees.

LAT: Latitude of the building location, degrees (see Table C1).

TZN: Time zone number:

- 5 Eastern Standard time zone
- 6 Central Standard time zone
- 7 Mountain Standard time zone
- 8 Pacific Standard time zone

ZLF: Room exterior wall perimeter, ft.*.

RHOW: Outdoor air relative humidity for a design heating load calculation, %.

(real variable)

| LONG | LAT | TZN | ZLF | RHOW | | | | | |
|------|-----|-----|-----|------|--|--|--|--|--|
| | | | | | | | | | |

* For interior space, use the perimeter bounded by non-air conditioned spaces.

The value of ZL is needed only when ASHRAE = 1. If the value is unknown use ZL = 10. For the case ASHRAE = 0 use ZL = 0.

Data Sheet 4

NAMERM

After this card, the data that follow will refer to this specific room or space in the building.

NAME OF THE ROOM

| | | | | | | | | | | | | | | | | | | | | | | | | | | | | | | | | | | | | | | | | | | | | | |
|---|---|---|---|---|---|---|---|---|----|----|----|----|----|----|----|----|----|----|----|----|----|----|----|----|----|----|----|----|----|----|----|----|----|----|----|----|----|----|----|----|----|--|--|--|--|
| 1 | 2 | 3 | 4 | 5 | 6 | 7 | 8 | 9 | 10 | 11 | 12 | 13 | 14 | 15 | 16 | 17 | 18 | 19 | 20 | 21 | 22 | 23 | 24 | 25 | 26 | 27 | 28 | 29 | 30 | 31 | 32 | 33 | 34 | 35 | 36 | 37 | 38 | 39 | 40 | 41 | 42 | | | | |
| X | X | | | | | | | | | | | | | | | | | | | | | | | | | | | | | | | | | | | | | | | | | | | | |

Start from Column 3

(Alphanumeric data; 34 columns maximum)

Data Sheet 5

IROT: Room rotation index:

= 0: if the room load is to be calculated without reference to any previously described room.

= number of degrees: if this room is to be the same as the previous room except for rotation clockwise a specified number of integer degrees.

ISKIP: Wall/Roof/Floor construction data skip:

= 0: if the room requires a new set of wall/roof/floor construction data.

= 1: if the wall/roof/floor data used by the previous room is reused for this room. If ISKIP = 0, data sheets 6 and 7 should be omitted.

INCLUD: Space load summation index:

= 1: space load not included in the summation.

= 0: space load included in a summation of the space load of the previous room.

(integer variables)

| | | | | | | | | | |
|------|-------|--------|--|--|--|--|--|--|--|
| IROT | ISKIP | INCLUD | | | | | | | |
| | | | | | | | | | |

Data Sheet 6

Wall/Roof/Floor-A

N: number of layers of composition in a given wall/roof/floor construction.

By referring to the data of Table C3 (taken from the 1972 ASHRAE Handbook of Fundamentals), give the following information for each of the layers starting from the innermost layer to the Nth layer, which is the outermost layer.

L: Thickness of the layer, ft.

K: Thermal conductivity of the layer, Btuh per (hr) (ft) ($^{\circ}$ F).

P: Density of the layer material, lb per cu. ft.

C: Specific heat of the layer material, Btu per (lb) ($^{\circ}$ F).

R: Thermal resistance value of the layer in (hr) (sq. ft.) ($^{\circ}$ F) per Btu.

For the calculation where the ASHRAE weighting factor method is used (ASHRAE = 1), the inner most layer is always the inside surface thermal resistance. If ASHRAE = 0, omit the inside surface thermal resistance. Outside surface thermal resistance is never used in all cases.

The value of R is to be given only when the layer has no apparent thermal mass. If the value of L, K, P, and C are given, R should be zero. If R is given, L, K, P, and C should all be zero, in particular, L should be zero even if it is physically non-zero. For the ground floor, add a finite thickness slab consisting of a 12" thick earth layer.

Note: (1) At least one of the N layers should have non-zero values of L, K, P, and C.

(2) If two or more consecutive layers have no thermal mass, their thermal resistance values should be combined.

(3) If a particular wall is considered to have no appreciable thermal mass, or if it is desired not to consider the thermal mass effect, data for this particular wall should not be included in the data sheets.

IRF*
1

(integer)

| | | | | | | | | | |
|---|--|--|--|--|--|--|--|--|--|
| N | | | | | | | | | |
|---|--|--|--|--|--|--|--|--|--|

(real number)

| L | K | P | C | R | |
|---|---|---|---|---|-----------------------|
| | | | | | 1st LAYER - innermost |
| | | | | | 2nd LAYER |
| | | | | | 3rd LAYER |
| | | | | | 4th LAYER |
| | | | | | |
| | | | | | |
| | | | | | |
| | | | | | |
| | | | | | |
| | | | | | Nth LAYER |

* IRF is not the input data in this data sheet. It is the identifier of the particular wall in the sheet.

Data Sheet 7

Wall/Roof/Floor-B

Twenty-four characters are allowed for the brief description of each layer, such as "common brick" or "1/2" plaster board", etc.

The description should identify the corresponding layer given on Data Sheet 6.

The set of wall/roof/floor data and accompanying description will be repeated as many times as there are number of different wall/roof/floor constructions (with an upper limit of 9) pertinent to the room under consideration. Each new set of wall/roof/floor construction will be identified by the IRF number on DATA SHEET 6 (upper right hand corner).

After the last wall/roof/floor has been given, provide a line with 0 or a blank card to indicate that fact.

| DESCRIPTION FOR LAYER I THROUGH LAYER N | | | | | | | | | | | | | | | | | | | | | | | |
|--|--|--|--|--|--|--|--|--|--|--|--|--|--|--|--|--|--|--|--|--|--|--|--|
| | | | | | | | | | | | | | | | | | | | | | | | |
| | | | | | | | | | | | | | | | | | | | | | | | |
| | | | | | | | | | | | | | | | | | | | | | | | |
| | | | | | | | | | | | | | | | | | | | | | | | |
| | | | | | | | | | | | | | | | | | | | | | | | |
| | | | | | | | | | | | | | | | | | | | | | | | |
| | | | | | | | | | | | | | | | | | | | | | | | |
| | | | | | | | | | | | | | | | | | | | | | | | |
| | | | | | | | | | | | | | | | | | | | | | | | |
| | | | | | | | | | | | | | | | | | | | | | | | |
| | | | | | | | | | | | | | | | | | | | | | | | |
| | | | | | | | | | | | | | | | | | | | | | | | |
| | | | | | | | | | | | | | | | | | | | | | | | |
| Blank card if this is the last wall/roof/floor | | | | | | | | | | | | | | | | | | | | | | | |
| (Alphanumeric information) | | | | | | | | | | | | | | | | | | | | | | | |

| | | | | | | | | | |
|---|--|--|--|--|--|--|--|--|--|
| N | | | | | | | | | |
|---|--|--|--|--|--|--|--|--|--|

| L | K | P | C | R | |
|---|---|---|---|---|-----------------------|
| | | | | | 1st LAYER - innermost |
| | | | | | 2nd LAYER |
| | | | | | 3rd LAYER |
| | | | | | 4th LAYER |
| | | | | | |
| | | | | | |
| | | | | | |
| | | | | | |
| | | | | | Nth LAYER |

| DESCRIPTION FOR LAYER I THROUGH LAYER N | | | | | | | | | | | | | | | | | | | |
|---|--|--|--|--|--|--|--|--|--|--|--|--|--|--|--|--|--|--|--|
| | | | | | | | | | | | | | | | | | | | |
| | | | | | | | | | | | | | | | | | | | |
| | | | | | | | | | | | | | | | | | | | |
| | | | | | | | | | | | | | | | | | | | |
| | | | | | | | | | | | | | | | | | | | |
| | | | | | | | | | | | | | | | | | | | |
| | | | | | | | | | | | | | | | | | | | |
| | | | | | | | | | | | | | | | | | | | |
| | | | | | | | | | | | | | | | | | | | |
| | | | | | | | | | | | | | | | | | | | |
| | | | | | | | | | | | | | | | | | | | |
| | | | | | | | | | | | | | | | | | | | |
| | | | | | | | | | | | | | | | | | | | |
| | | | | | | | | | | | | | | | | | | | |
| | | | | | | | | | | | | | | | | | | | |

Blank card if this is the last wall/roof/floor

| | | | | | | | | | | | | | | | | | | | |
|--|--|--|--|--|--|--|--|--|--|--|--|--|--|--|--|--|--|--|--|
| | | | | | | | | | | | | | | | | | | | |
|--|--|--|--|--|--|--|--|--|--|--|--|--|--|--|--|--|--|--|--|

(Alphanumeric information)

| |
|----------|
| IRF 3 |
|----------|

Data Sheet 6

| | | | | | | | | | |
|---|--|--|--|--|--|--|--|--|--|
| N | | | | | | | | | |
| | | | | | | | | | |

| L | K | P | C | R | |
|---|---|---|---|---|-----------------------|
| | | | | | 1st LAYER - innermost |
| | | | | | 2nd LAYER |
| | | | | | 3rd LAYER |
| | | | | | 4th LAYER |
| | | | | | |
| | | | | | |
| | | | | | |
| | | | | | |
| | | | | | |
| | | | | | Nth LAYER |

Data Sheet 7

| | | | | | | | | | | | | | | | | | | | | | | | | | | | | | | | | | |
|---|--|--|--|--|--|--|--|--|--|--|--|--|--|--|--|--|--|--|--|--|--|--|--|--|--|--|--|--|--|--|--|--|--|
| DESCRIPTION FOR LAYER I THROUGH LAYER N | | | | | | | | | | | | | | | | | | | | | | | | | | | | | | | | | |
| | | | | | | | | | | | | | | | | | | | | | | | | | | | | | | | | | |
| | | | | | | | | | | | | | | | | | | | | | | | | | | | | | | | | | |
| | | | | | | | | | | | | | | | | | | | | | | | | | | | | | | | | | |
| | | | | | | | | | | | | | | | | | | | | | | | | | | | | | | | | | |
| | | | | | | | | | | | | | | | | | | | | | | | | | | | | | | | | | |
| | | | | | | | | | | | | | | | | | | | | | | | | | | | | | | | | | |
| | | | | | | | | | | | | | | | | | | | | | | | | | | | | | | | | | |
| | | | | | | | | | | | | | | | | | | | | | | | | | | | | | | | | | |
| | | | | | | | | | | | | | | | | | | | | | | | | | | | | | | | | | |
| | | | | | | | | | | | | | | | | | | | | | | | | | | | | | | | | | |
| | | | | | | | | | | | | | | | | | | | | | | | | | | | | | | | | | |
| | | | | | | | | | | | | | | | | | | | | | | | | | | | | | | | | | |
| | | | | | | | | | | | | | | | | | | | | | | | | | | | | | | | | | |
| | | | | | | | | | | | | | | | | | | | | | | | | | | | | | | | | | |
| | | | | | | | | | | | | | | | | | | | | | | | | | | | | | | | | | |
| | | | | | | | | | | | | | | | | | | | | | | | | | | | | | | | | | |
| | | | | | | | | | | | | | | | | | | | | | | | | | | | | | | | | | |
| | | | | | | | | | | | | | | | | | | | | | | | | | | | | | | | | | |
| | | | | | | | | | | | | | | | | | | | | | | | | | | | | | | | | | |
| | | | | | | | | | | | | | | | | | | | | | | | | | | | | | | | | | |
| | | | | | | | | | | | | | | | | | | | | | | | | | | | | | | | | | |
| | | | | | | | | | | | | | | | | | | | | | | | | | | | | | | | | | |
| | | | | | | | | | | | | | | | | | | | | | | | | | | | | | | | | | |
| | | | | | | | | | | | | | | | | | | | | | | | | | | | | | | | | | |
| | | | | | | | | | | | | | | | | | | | | | | | | | | | | | | | | | |
| | | | | | | | | | | | | | | | | | | | | | | | | | | | | | | | | | |
| | | | | | | | | | | | | | | | | | | | | | | | | | | | | | | | | | |
| | | | | | | | | | | | | | | | | | | | | | | | | | | | | | | | | | |
| | | | | | | | | | | | | | | | | | | | | | | | | | | | | | | | | | |
| | | | | | | | | | | | | | | | | | | | | | | | | | | | | | | | | | |
| | | | | | | | | | | | | | | | | | | | | | | | | | | | | | | | | | |
| | | | | | | | | | | | | | | | | | | | | | | | | | | | | | | | | | |

Blank card if this is the last wall/roof/floor

| | | | | | | | | | | | | | | | | | | | | | | | | | | | | | | | | | | | |
|--|--|--|--|--|--|--|--|--|--|--|--|--|--|--|--|--|--|--|--|--|--|--|--|--|--|--|--|--|--|--|--|--|--|--|--|
| | | | | | | | | | | | | | | | | | | | | | | | | | | | | | | | | | | | |
|--|--|--|--|--|--|--|--|--|--|--|--|--|--|--|--|--|--|--|--|--|--|--|--|--|--|--|--|--|--|--|--|--|--|--|--|

(Alphanumeric information)

| | | | | | | | | | |
|---|--|--|--|--|--|--|--|--|--|
| N | | | | | | | | | |
| | | | | | | | | | |

| L | K | P | C | R | |
|---|---|---|---|---|-----------------------|
| | | | | | 1st LAYER - innermost |
| | | | | | 2nd LAYER |
| | | | | | 3rd LAYER |
| | | | | | 4th LAYER |
| | | | | | |
| | | | | | |
| | | | | | |
| | | | | | |
| | | | | | |
| | | | | | |
| | | | | | |
| | | | | | |
| | | | | | |
| | | | | | Nth LAYER |

| | | | | | | | | | | | | | | | | | | | | | | | | | | | | | | | |
|--|--|--|--|--|--|--|--|--|--|--|--|--|--|--|--|--|--|--|--|--|--|--|--|--|--|--|--|--|--|--|--|
| DESCRIPTION FOR LAYER I THROUGH LAYER N | | | | | | | | | | | | | | | | | | | | | | | | | | | | | | | |
| | | | | | | | | | | | | | | | | | | | | | | | | | | | | | | | |
| | | | | | | | | | | | | | | | | | | | | | | | | | | | | | | | |
| | | | | | | | | | | | | | | | | | | | | | | | | | | | | | | | |
| | | | | | | | | | | | | | | | | | | | | | | | | | | | | | | | |
| | | | | | | | | | | | | | | | | | | | | | | | | | | | | | | | |
| | | | | | | | | | | | | | | | | | | | | | | | | | | | | | | | |
| | | | | | | | | | | | | | | | | | | | | | | | | | | | | | | | |
| | | | | | | | | | | | | | | | | | | | | | | | | | | | | | | | |
| | | | | | | | | | | | | | | | | | | | | | | | | | | | | | | | |
| | | | | | | | | | | | | | | | | | | | | | | | | | | | | | | | |
| | | | | | | | | | | | | | | | | | | | | | | | | | | | | | | | |
| | | | | | | | | | | | | | | | | | | | | | | | | | | | | | | | |
| | | | | | | | | | | | | | | | | | | | | | | | | | | | | | | | |
| | | | | | | | | | | | | | | | | | | | | | | | | | | | | | | | |
| | | | | | | | | | | | | | | | | | | | | | | | | | | | | | | | |
| | | | | | | | | | | | | | | | | | | | | | | | | | | | | | | | |
| | | | | | | | | | | | | | | | | | | | | | | | | | | | | | | | |
| | | | | | | | | | | | | | | | | | | | | | | | | | | | | | | | |
| | | | | | | | | | | | | | | | | | | | | | | | | | | | | | | | |
| | | | | | | | | | | | | | | | | | | | | | | | | | | | | | | | |
| | | | | | | | | | | | | | | | | | | | | | | | | | | | | | | | |
| | | | | | | | | | | | | | | | | | | | | | | | | | | | | | | | |
| | | | | | | | | | | | | | | | | | | | | | | | | | | | | | | | |
| | | | | | | | | | | | | | | | | | | | | | | | | | | | | | | | |
| | | | | | | | | | | | | | | | | | | | | | | | | | | | | | | | |
| | | | | | | | | | | | | | | | | | | | | | | | | | | | | | | | |
| | | | | | | | | | | | | | | | | | | | | | | | | | | | | | | | |

Blank card if this is the last wall/roof/floor

| | | | | | | | | | | | | | | | | | | | | | | | | | | | | | | | |
|--|--|--|--|--|--|--|--|--|--|--|--|--|--|--|--|--|--|--|--|--|--|--|--|--|--|--|--|--|--|--|--|
| | | | | | | | | | | | | | | | | | | | | | | | | | | | | | | | |
|--|--|--|--|--|--|--|--|--|--|--|--|--|--|--|--|--|--|--|--|--|--|--|--|--|--|--|--|--|--|--|--|

(Alphanumeric information)

Data Sheet 6

IRF
8

Wall/Roof/Floor-A

| | | | | | | | | | |
|---|--|--|--|--|--|--|--|--|--|
| N | | | | | | | | | |
| | | | | | | | | | |

| L | K | P | C | R | |
|---|---|---|---|---|-----------------------|
| | | | | | 1st LAYER - innermost |
| | | | | | 2nd LAYER |
| | | | | | 3rd LAYER |
| | | | | | 4th LAYER |
| | | | | | |
| | | | | | |
| | | | | | |
| | | | | | |
| | | | | | |
| | | | | | Nth LAYER |

Data Sheet 7

| DESCRIPTION FOR LAYER I THROUGH LAYER N | | | | | | | | | | | | | | | | | | | | | | | | | | | | | |
|---|--|--|--|--|--|--|--|--|--|--|--|--|--|--|--|--|--|--|--|--|--|--|--|--|--|--|--|--|--|
| | | | | | | | | | | | | | | | | | | | | | | | | | | | | | |
| | | | | | | | | | | | | | | | | | | | | | | | | | | | | | |
| | | | | | | | | | | | | | | | | | | | | | | | | | | | | | |
| | | | | | | | | | | | | | | | | | | | | | | | | | | | | | |
| | | | | | | | | | | | | | | | | | | | | | | | | | | | | | |
| | | | | | | | | | | | | | | | | | | | | | | | | | | | | | |
| | | | | | | | | | | | | | | | | | | | | | | | | | | | | | |
| | | | | | | | | | | | | | | | | | | | | | | | | | | | | | |
| | | | | | | | | | | | | | | | | | | | | | | | | | | | | | |
| | | | | | | | | | | | | | | | | | | | | | | | | | | | | | |
| | | | | | | | | | | | | | | | | | | | | | | | | | | | | | |
| | | | | | | | | | | | | | | | | | | | | | | | | | | | | | |
| | | | | | | | | | | | | | | | | | | | | | | | | | | | | | |
| | | | | | | | | | | | | | | | | | | | | | | | | | | | | | |

Blank card if this is the last wall/roof/floor

| | | | | | | | | | | | | | | | | | | | | | | | | | | | | | | | |
|--|--|--|--|--|--|--|--|--|--|--|--|--|--|--|--|--|--|--|--|--|--|--|--|--|--|--|--|--|--|--|--|
| | | | | | | | | | | | | | | | | | | | | | | | | | | | | | | | |
|--|--|--|--|--|--|--|--|--|--|--|--|--|--|--|--|--|--|--|--|--|--|--|--|--|--|--|--|--|--|--|--|

(Alphanumeric information)

| | | | | | | | | |
|---|--|--|--|--|--|--|--|--|
| N | | | | | | | | |
|---|--|--|--|--|--|--|--|--|

| L | K | P | C | R | |
|---|---|---|---|---|-----------------------|
| | | | | | 1st LAYER - innermost |
| | | | | | 2nd LAYER |
| | | | | | 3rd LAYER |
| | | | | | 4th LAYER |
| | | | | | |
| | | | | | |
| | | | | | |
| | | | | | |
| | | | | | |
| | | | | | |
| | | | | | |
| | | | | | |
| | | | | | |
| | | | | | |
| | | | | | |
| | | | | | |
| | | | | | |
| | | | | | |
| | | | | | |
| | | | | | |
| | | | | | |
| | | | | | |
| | | | | | |
| | | | | | |
| | | | | | Nth LAYER |

| DESCRIPTION FOR LAYER I THROUGH LAYER N | | | | | | | | | | | | | | | | | |
|---|--|--|--|--|--|--|--|--|--|--|--|--|--|--|--|--|--|
| | | | | | | | | | | | | | | | | | |
| | | | | | | | | | | | | | | | | | |
| | | | | | | | | | | | | | | | | | |
| | | | | | | | | | | | | | | | | | |
| | | | | | | | | | | | | | | | | | |
| | | | | | | | | | | | | | | | | | |
| | | | | | | | | | | | | | | | | | |
| | | | | | | | | | | | | | | | | | |
| | | | | | | | | | | | | | | | | | |
| | | | | | | | | | | | | | | | | | |
| | | | | | | | | | | | | | | | | | |
| | | | | | | | | | | | | | | | | | |
| | | | | | | | | | | | | | | | | | |
| | | | | | | | | | | | | | | | | | |
| | | | | | | | | | | | | | | | | | |
| | | | | | | | | | | | | | | | | | |
| | | | | | | | | | | | | | | | | | |
| | | | | | | | | | | | | | | | | | |
| | | | | | | | | | | | | | | | | | |
| | | | | | | | | | | | | | | | | | |
| | | | | | | | | | | | | | | | | | |
| | | | | | | | | | | | | | | | | | |
| | | | | | | | | | | | | | | | | | |
| | | | | | | | | | | | | | | | | | |
| | | | | | | | | | | | | | | | | | |
| | | | | | | | | | | | | | | | | | |
| | | | | | | | | | | | | | | | | | |
| | | | | | | | | | | | | | | | | | |
| | | | | | | | | | | | | | | | | | |
| | | | | | | | | | | | | | | | | | |
| | | | | | | | | | | | | | | | | | |
| | | | | | | | | | | | | | | | | | |
| | | | | | | | | | | | | | | | | | |

Blank card if this is the last wall/roof/floor

| | | | | | | | | | | | | | | | | | |
|--|--|--|--|--|--|--|--|--|--|--|--|--|--|--|--|--|--|
| | | | | | | | | | | | | | | | | | |
|--|--|--|--|--|--|--|--|--|--|--|--|--|--|--|--|--|--|

(Alphanumeric information)

* IRF should not exceed 9 since IRF = 10 is reserved for very lightweight walls, doors and windows in Data Sheet 11.

CFMS: Flow rate of outdoor air introduced for natural cooling purposes, cu. ft. per minute, for the temperature calculation, or the flow rate of outdoor air brought into the room by mechanical means during the occupied period to reduce the cooling load (NVENT = 1). This data should be zero when RUNTYP (page 4c) = 1.

ARCHGS: Infiltration in terms of number of air changes per hour during the summer* months.

ARCHGW: Infiltration in terms of number of air changes per hour during the winter** months.

ARCHGM: Minimum infiltration in terms of air changes per hour when ARCHGS = 0 and ARCHGW = 0.

ZNORM: Number of rooms of the same type being described in the building.

* June through September.

** October through May.

| ROOMNO | QLITY | QEQPX | QCU | FLCG | FRAS | TS | CFMS | ARCHGS | ARCHGW |
|--------|-------|-------|-----|------|------|----|------|--------|--------|
| | | | | | | | | | |
| ARCHGM | ZNORM | | | | | | | | |
| | | | | | | | | | |

Data Sheet 8

ROOMNO: Room identification number.

QLITY: Maximum lighting power input to the room, expressed as watts per sq. ft. of floor area (see Table C4).

QEQPX: Maximum electric power input for the appliances and other equipment in the room exclusive of the heating and air conditioning equipment, expressed as watts per sq. ft. of floor area (see Table C4).

QCU: Maximum number of adult occupants in the room during the day (count a child as 0.5).

FLCG: Fraction of electric power for lighting which can be assumed to go directly to the return air.

FRAS: Fraction of internal heat gains which can be assumed to be absorbed by the room surfaces instantaneously (as a result of radiation).

TS: Supply air temperature to the room from heating/cooling system, °F, for the room temperature calculation, or the upper temperature limit on outdoor air which can be brought in during the occupied period to reduce the cooling load (NVENT = 1) - Data Sheet 16.

Data Sheet 9*

IW: Building weight index:

IW = 1 Heavy structure (approximately 70 lb per sq. ft. of floor use or above).

IW = 2 Medium weight structure (between 30 and 70 lb per sq. ft. of floor area).

IW = 3 Lightweight structure (below 30 lb per sq. ft. of floor area).

IL: Lighting fixture index.

ISTART: Starting hour of occupancy.

ILEAVE: Ending hour of occupancy.

* This data is used only when ASHRAE = 1.

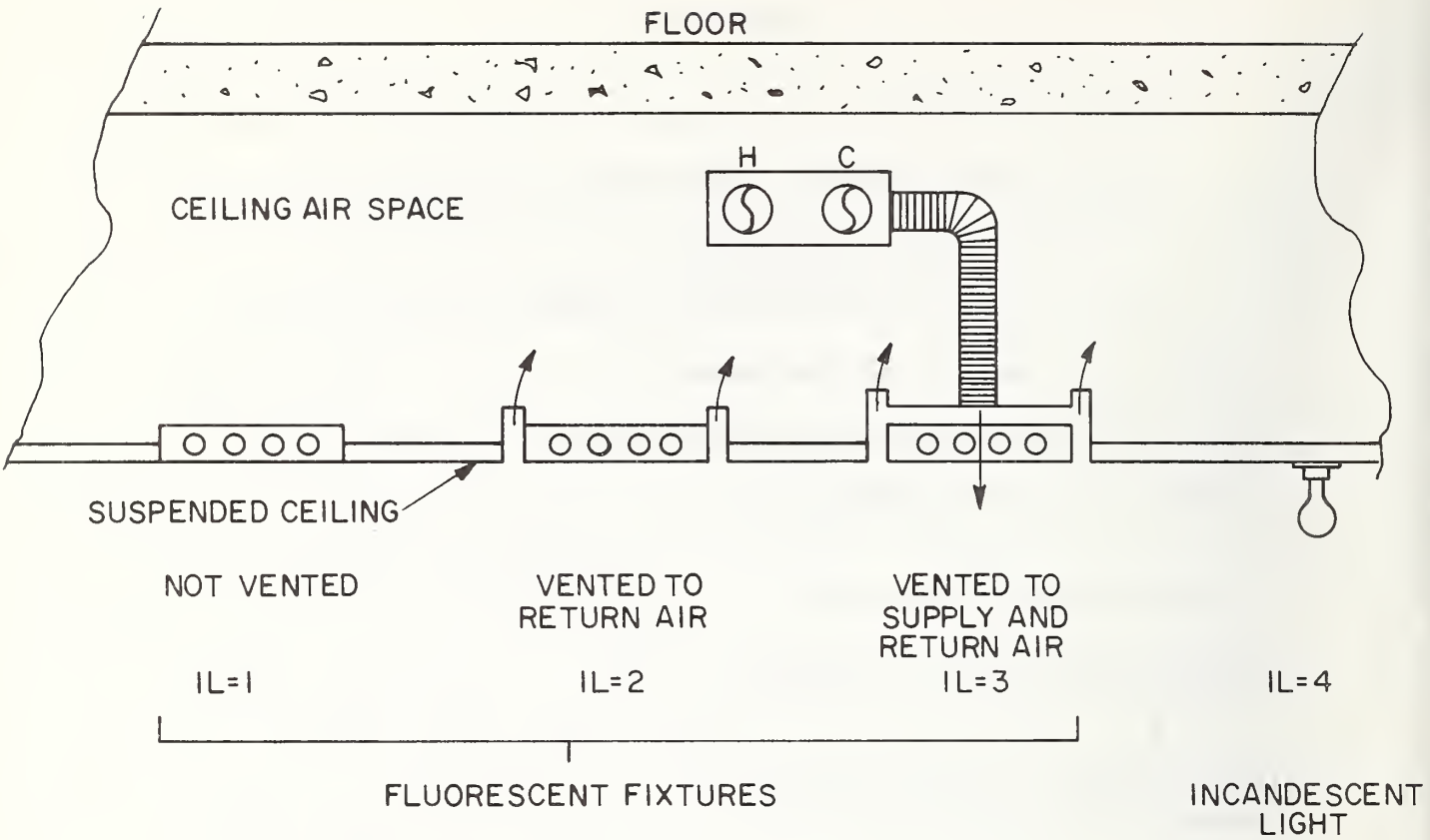

| IW | IL | ISTART | ILEAVE | | | | | | |
|----|----|--------|--------|--|--|--|--|--|--|
| | | | | | | | | | |

Data Sheet 10

Temperature Control Data

TUL: Upper limit of thermostat, above which the room requires cooling, °F.

TLL: Lower limit of thermostat, below which the room requires heating, °F.

QCMAX: Maximum sensible cooling capacity of the room air supply system, Btu per hour (for the design load calculation this data should be zero) ... non-negative value.

QHMAX: Maximum sensible heating capacity of the room air supply system, Btu per hour (for the design load calculation this data should be zero) ... non-negative value.

DBVMAX: Maximum outdoor temperature when the natural cooling by ventilation (economizer cycle) is used.

DBVMIN: Minimum outdoor temperature, below which the economizer cycle is disengaged.

| | | | | | | | | | |
|-----|-----|-------|-------|--------|--------|--|--|--|--|
| TUL | TLL | QCMAX | QHMAX | DBVMAX | DBVMIN | | | | |
| | | | | | | | | | |

Data Sheet 11

Temperature Control Indices, ITHST and ITK

ITHST = 1, ITK = 0: The hourly profile of room temperature, either constant or night setback, is prescribed ...

Figure C2.

ITHST = 0, ITK = 1: The room temperature is to be calculated for the room which is neither heated nor cooled ...

Figure C3.

ITHST = 1, ITK = 1: The upper and lower limit of the room temperature are given. The room will be heated if the room temperature falls below the lower limit TLL and the room is cooled if the room temperature rises above the upper limit TUL. As long as the room temperature is between these two limits, the room is neither heated nor cooled ... Figure C4.

ITHST = 0, ITK = 0: The same as above except that the maximum capacities of heating and cooling systems are introduced. If the room heating and cooling loads exceed the system heating and cooling capacities respectively, the room temperature drift from the set points TLL and TUL is calculated ...

Figure C5.

| | | | | | | | | | |
|-------|-----|--|--|--|--|--|--|--|--|
| ITHST | ITK | | | | | | | | |
| | | | | | | | | | |

(1) CONSTANT TEMPERATURE MODE

(ITHST=1)

ITK=0

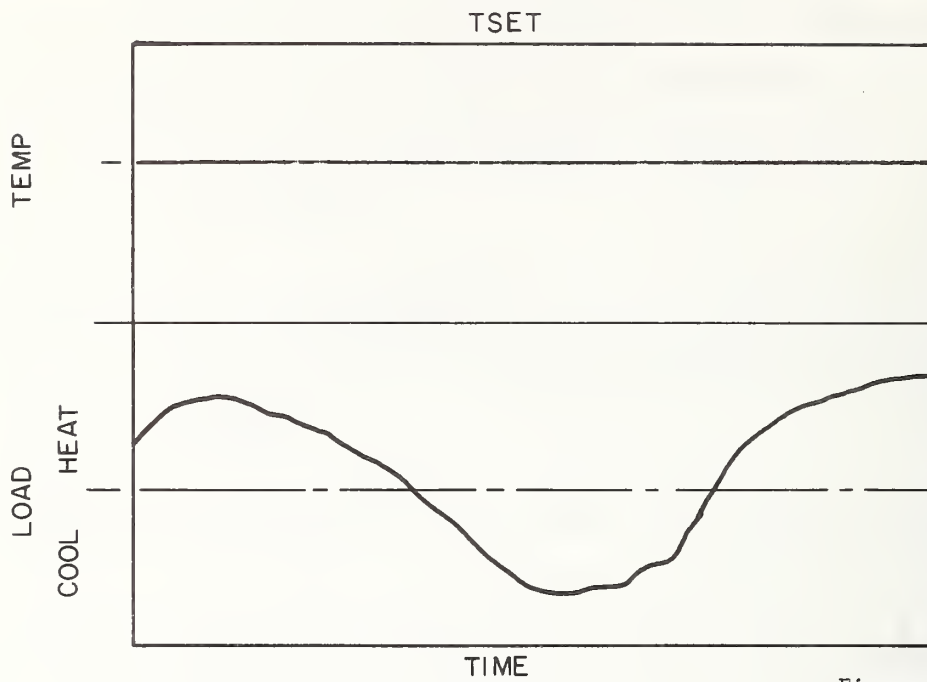

Figure C2

(2) FLOATING TEMPERATURE MODE

(ITHST=0

ITK=1

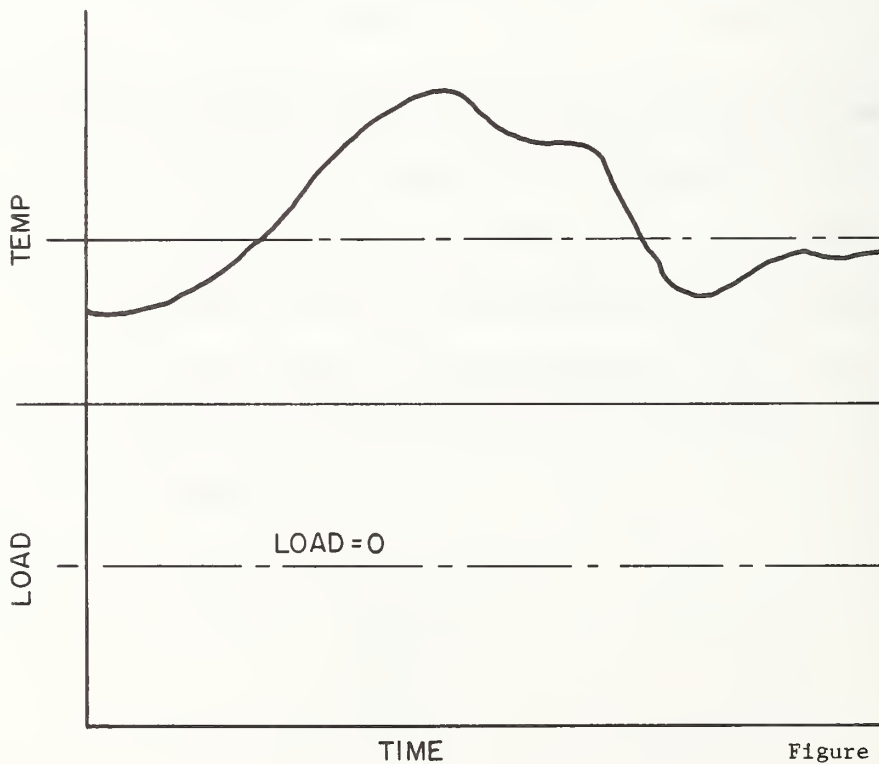
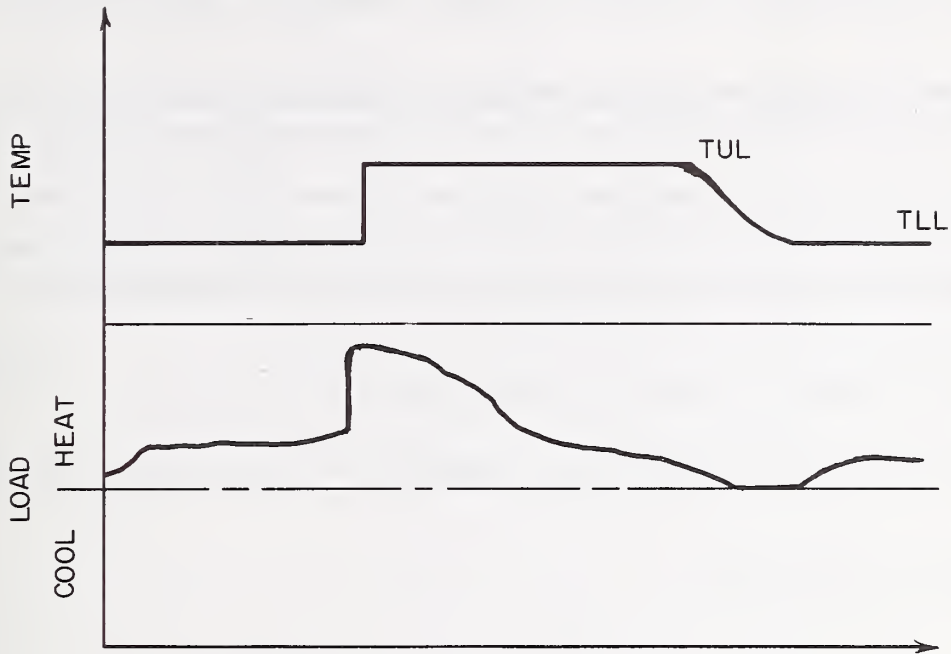

Figure C3

(3) PRESCRIBE TEMPERATURE **LIMIT** MODE
(ITHST=1)
(ITK=1)



(4) CONTROL SIMULATION MODE
(ITHST=0)
(ITK=0)

Figure C4

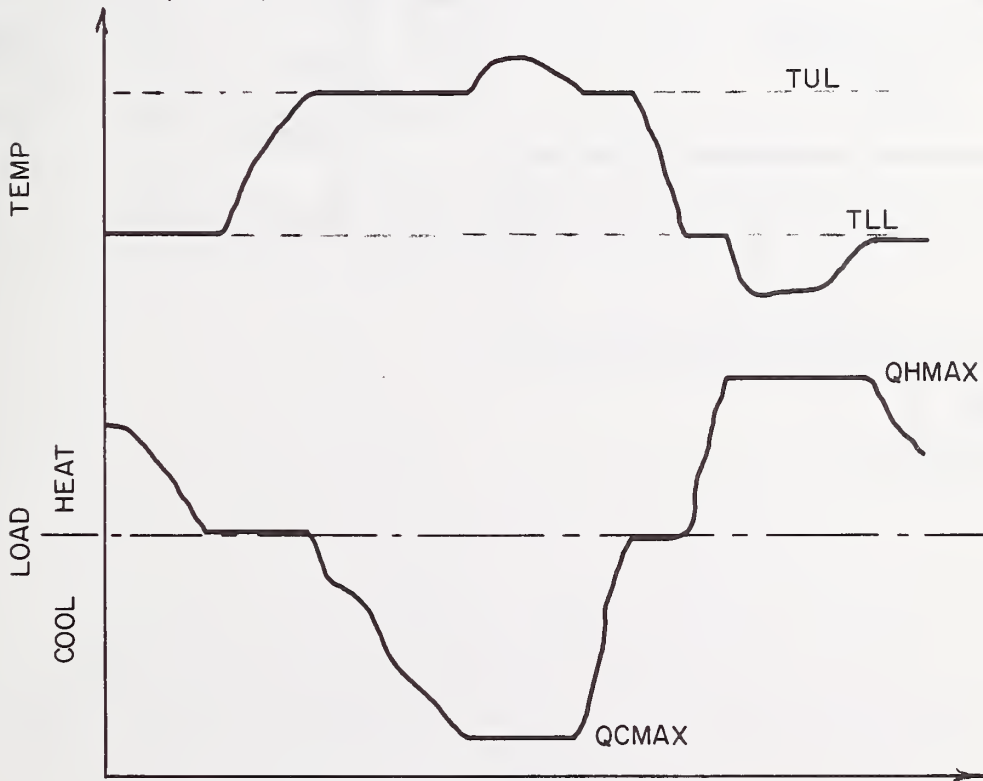

Figure C5

Data Sheet 12

NS: Number of different type heat transfer surfaces in the south wall.

NW: Number of different type heat transfer surfaces in the west wall.

NN: Number of different type heat transfer surfaces in the north wall.

NE: Number of different type heat transfer surfaces in the east wall.

L: Length of the room along the south wall, ft.

W: Width of the room along the west wall, ft.

H: Height of the room ft.

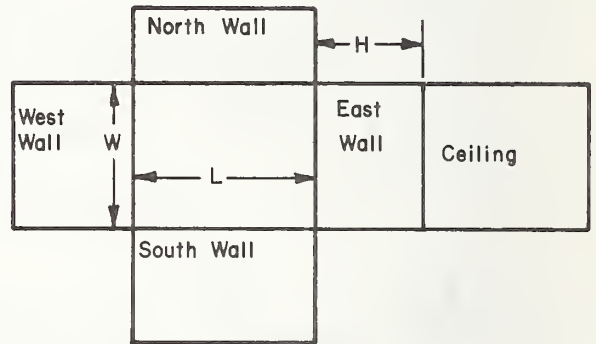
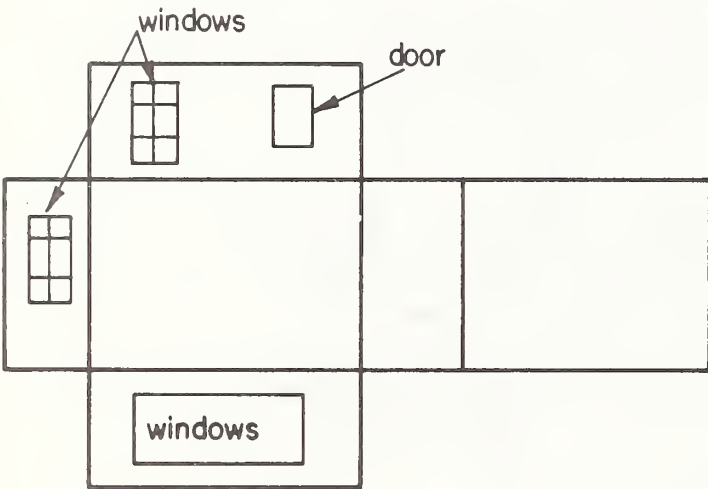

(integers)*

| | | | | | | | | | |
|----|----|----|----|--|--|--|--|--|--|
| NS | NW | NN | NE | | | | | | |
| | | | | | | | | | |
| L | W | H | | | | | | | |
| | | | | | | | | | |

(real values)

* $NS + NW + NN + NE$ should not exceed 28.

Data Sheet 13*

ITYPE : Exposure surface type index:

- = 1 if roof.
- = 2 if exterior wall.
- = 3 if window or glass door.
- = 4 if door.
- = 5 if floor on ground or basement wall.
- = 6 if partition walls, party walls, floor/ceiling, furnishings and other internal mass.
- = 7 if completely open.
- = 8 if the adjacent space is not air conditioned and will be considered as having a temperature the same as the outdoors.

IRF: Roof/wall/floor construction identifier index shown in the upper right corner of the roof/wall/floor data sheet 6. If not applicable (such as the cases for lightweight walls, doors and windows), which are not specified in data sheets 6 and 7. IRF = 10.

A: Area of the surface, sq. ft.

AZW: Surface orientation angle, degrees clockwise from south:

- 0 for south facing surface, roof/ceiling or floor.
- 45 for southwest facing surface.

* See note on data sheet 14.

- 90 for west facing surface.
- 135 for northwest facing surface.
- 180 for north facing surface.
- 135 for northeast facing surface.
- 90 for east facing surface.

U: Overall heat transfer coefficient of a surface (Btuh) for which the data for roof/wall/floor are not provided (IRF = 10). For the surface for which roof/wall/floor data are provided (IRF \neq 10), U should be zero because it will be computed in the program.

SHADE: Shading coefficient for the ITYPE = 3 surface (window or glass door) (see Table C5 which has been taken from the 1972 ASHRAE Handbook of Fundamentals). For all other types of surfaces, this parameter should be zero.

ABSP: Solar absorption coefficient for the exterior surface (see Table C6 which has been taken from Thermal Radiation Properties Survey, G. G. Gubareff, J. E. Jansen, and R. H. Torborg, Honeywell Research Center, 1960). This value should be zero for the surfaces of ITYPE = 3, 5, 6 and 7, and 8.

SHDW: Shadow parameter = 1 if completely shaded by an adjacent building or an external shading device; = 0 if otherwise.

integer

real variable

| | | | | | | | | | |
|-------|-----|---|-----|---|-------|------|-----|--|--|
| ITYPE | IRF | A | AZW | U | SHADE | ABSP | SHD | | |
| | | | | | | | | | |

Data Sheet 14*

Room Surfaces - B

(Exterior Shading Device Data)

Data are given in ft. and as dictated by the figure below.

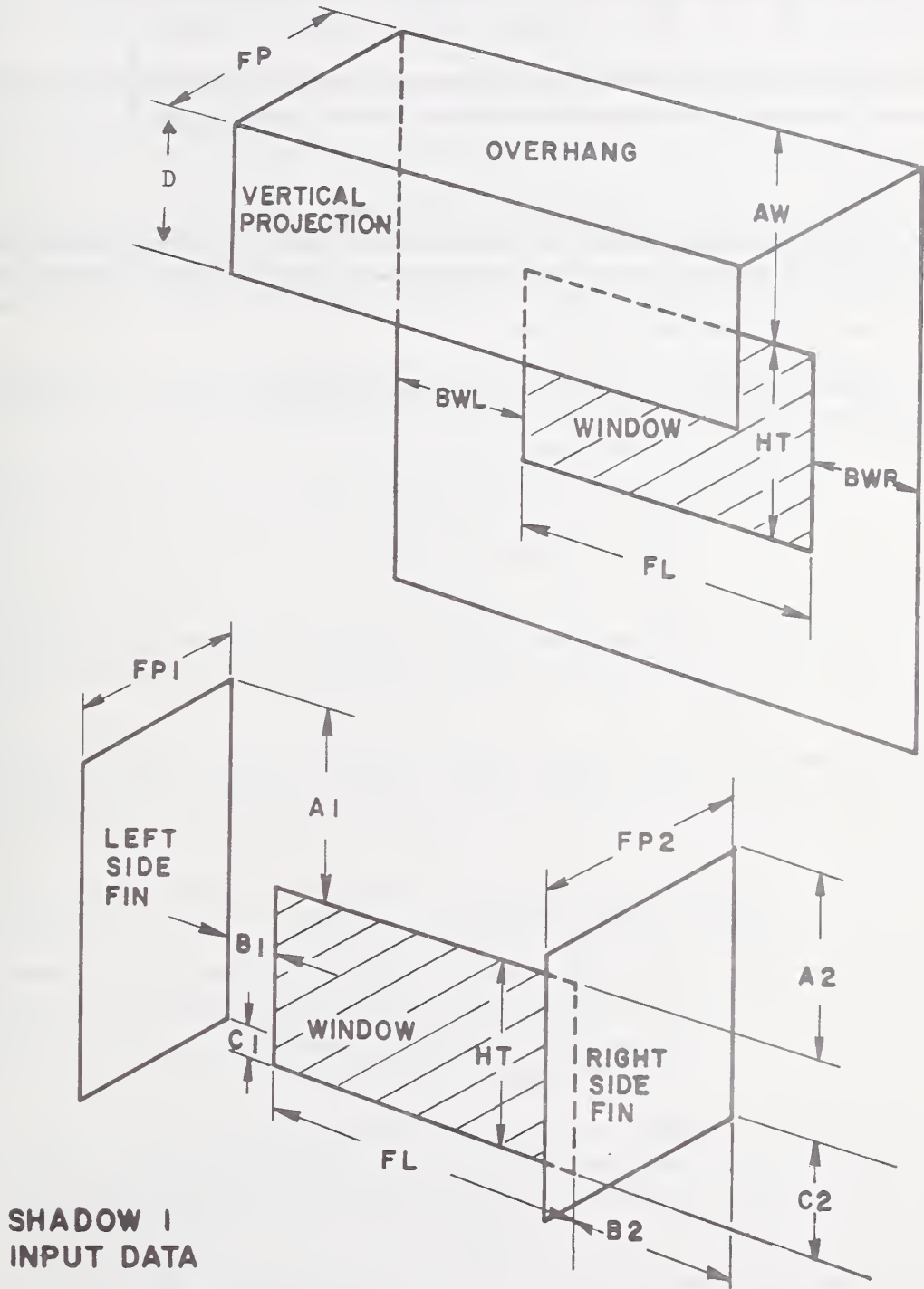

SHADOW I
INPUT DATA

| | | | | | | | | | |
|----|----|----|----|-----|-----|---|--|--|--|
| FL | HT | FP | AW | BWL | BWR | D | | | |
| | | | | | | | | | |

| | | | | | | | | | |
|-----|----|----|----|-----|----|----|----|--|--|
| FPI | AI | BI | CI | FP2 | A2 | B2 | C2 | | |
| | | | | | | | | | |

* The sequence of input should be roof/ceiling, south facing surfaces, west facing surfaces, north facing surfaces, east facing surfaces and floor. While each vertical exposure can accommodate more than one type of surface such as wall, door and window, only one surface should be given for floor and roof/ceiling.

Data Sheets 11 and 12 are to be repeated for each of all the surfaces of the room.

Repetition of Data Sheets 13 and 14

| | | | | | | | | | |
|-------|-----|---|-----|---|-------|------|------|--|--|
| ITYPE | IRF | A | AZW | U | SHADE | ABSP | SHDW | | |
| | | | | | | | | | |

| | | | | | | | | | |
|----|----|----|----|-----|-----|---|--|--|--|
| FL | HT | FP | AW | BWL | BWR | D | | | |
| | | | | | | | | | |

| | | | | | | | | | |
|-----|----|----|----|-----|----|----|----|--|--|
| FPI | AI | BI | CI | FP2 | A2 | B2 | C2 | | |
| | | | | | | | | | |

| | | | | | | | | | |
|-------|-----|---|-----|---|-------|------|------|--|--|
| ITYPE | IRF | A | AZW | U | SHADE | ABSP | SHDW | | |
| | | | | | | | | | |

| | | | | | | | | | |
|----|----|----|----|-----|-----|---|--|--|--|
| FL | HT | FP | AW | BWL | BWR | D | | | |
| | | | | | | | | | |

| | | | | | | | | | |
|-----|----|----|----|-----|----|----|----|--|--|
| FPI | AI | BI | CI | FP2 | A2 | B2 | C2 | | |
| | | | | | | | | | |

| | | | | | | | | | |
|-------|-----|---|-----|---|-------|------|------|--|--|
| ITYPE | IRF | A | AZW | U | SHADE | ABSP | SHDW | | |
| | | | | | | | | | |

| | | | | | | | | | |
|----|----|----|----|-----|-----|---|--|--|--|
| FL | HT | FP | AW | BWL | BWR | D | | | |
| | | | | | | | | | |

| | | | | | | | | | |
|-----|----|----|----|-----|----|----|----|--|--|
| FPI | AI | BI | CI | FP2 | A2 | B2 | C2 | | |
| | | | | | | | | | |

Repetition of Data Sheets 13 and 14

| | | | | | | | | | |
|-------|-----|---|-----|---|-------|------|------|--|--|
| ITYPE | IRF | A | AZW | U | SHADE | ABSP | SHDW | | |
| | | | | | | | | | |

| | | | | | | | | | |
|----|----|----|----|-----|-----|---|--|--|--|
| FL | HT | FP | AW | BWL | BWR | D | | | |
| | | | | | | | | | |

| | | | | | | | | | |
|-----|----|----|----|-----|----|----|----|--|--|
| FPI | AI | BI | CI | FP2 | A2 | B2 | C2 | | |
| | | | | | | | | | |

| | | | | | | | | | |
|-------|-----|---|-----|---|-------|------|------|--|--|
| ITYPE | IRF | A | AZW | U | SHADE | ABSP | SHDW | | |
| | | | | | | | | | |

| | | | | | | | | | |
|----|----|----|----|-----|-----|---|--|--|--|
| FL | HT | FP | AW | BWL | BWR | D | | | |
| | | | | | | | | | |

| | | | | | | | | | |
|-----|----|----|----|-----|----|----|----|--|--|
| FPI | AI | BI | CI | FP2 | A2 | B2 | C2 | | |
| | | | | | | | | | |

| | | | | | | | | | |
|-------|-----|---|-----|---|-------|------|------|--|--|
| ITYPE | IRF | A | AZW | U | SHADE | ABSP | SHDW | | |
| | | | | | | | | | |

| | | | | | | | | | |
|----|----|----|----|-----|-----|---|--|--|--|
| FL | HT | FP | AW | BWL | BWR | D | | | |
| | | | | | | | | | |

| | | | | | | | | | |
|-----|----|----|----|-----|----|----|----|--|--|
| FPI | AI | BI | CI | FP2 | A2 | B2 | C2 | | |
| | | | | | | | | | |

Repetition of Data Sheets 13 and 14

| | | | | | | | | | |
|-------|-----|---|-----|---|-------|------|------|--|--|
| ITYPE | IRF | A | AZW | U | SHADE | ABSP | SHDW | | |
| | | | | | | | | | |

| | | | | | | | | | |
|----|----|----|----|-----|-----|---|--|--|--|
| FL | HT | FP | AW | BWL | BWR | D | | | |
| | | | | | | | | | |

| | | | | | | | | | |
|-----|----|----|----|-----|----|----|----|--|--|
| FPI | AI | BI | CI | FP2 | A2 | B2 | C2 | | |
| | | | | | | | | | |

| | | | | | | | | | |
|-------|-----|---|-----|---|-------|------|------|--|--|
| ITYPE | IRF | A | AZW | U | SHADE | ABSP | SHDW | | |
| | | | | | | | | | |

| | | | | | | | | | |
|----|----|----|----|-----|-----|---|--|--|--|
| FL | HT | FP | AW | BWL | BWR | D | | | |
| | | | | | | | | | |

| | | | | | | | | | |
|-----|----|----|----|-----|----|----|----|--|--|
| FPI | AI | BI | CI | FP2 | A2 | B2 | C2 | | |
| | | | | | | | | | |

| | | | | | | | | | |
|-------|-----|---|-----|---|-------|------|------|--|--|
| ITYPE | IRF | A | AZW | U | SHADE | ABSP | SHDW | | |
| | | | | | | | | | |

| | | | | | | | | | |
|----|----|----|----|-----|-----|---|--|--|--|
| FL | HT | FP | AW | BWL | BWR | D | | | |
| | | | | | | | | | |

| | | | | | | | | | |
|-----|----|----|----|-----|----|----|----|--|--|
| FPI | AI | BI | CI | FP2 | A2 | B2 | C2 | | |
| | | | | | | | | | |

Repetition of Data Sheets 13 and 14

| | | | | | | | | | |
|-------|-----|---|-----|---|-------|------|------|--|--|
| ITYPE | IRF | A | AZW | U | SHADE | ABSP | SHDW | | |
| | | | | | | | | | |

| | | | | | | | | | |
|----|----|----|----|-----|-----|---|--|--|--|
| FL | HT | FP | AW | BWL | BWR | D | | | |
| | | | | | | | | | |

| | | | | | | | | | |
|-----|----|----|----|-----|----|----|----|--|--|
| FPI | AI | BI | CI | FP2 | A2 | B2 | C2 | | |
| | | | | | | | | | |

| | | | | | | | | | |
|-------|-----|---|-----|---|-------|------|------|--|--|
| ITYPE | IRF | A | AZW | U | SHADE | ABSP | SHDW | | |
| | | | | | | | | | |

| | | | | | | | | | |
|----|----|----|----|-----|-----|---|--|--|--|
| FL | HT | FP | AW | BWL | BWR | D | | | |
| | | | | | | | | | |

| | | | | | | | | | |
|-----|----|----|----|-----|----|----|----|--|--|
| FPI | AI | BI | CI | FP2 | A2 | B2 | C2 | | |
| | | | | | | | | | |

| | | | | | | | | | |
|-------|-----|---|-----|---|-------|------|------|--|--|
| ITYPE | IRF | A | AZW | U | SHADE | ABSP | SHDW | | |
| | | | | | | | | | |

| | | | | | | | | | |
|----|----|----|----|-----|-----|---|--|--|--|
| FL | HT | FP | AW | BWL | BWR | D | | | |
| | | | | | | | | | |

| | | | | | | | | | |
|-----|----|----|----|-----|----|----|----|--|--|
| FPI | AI | BI | CI | FP2 | A2 | B2 | C2 | | |
| | | | | | | | | | |

Data Sheet 15*

UENDW: Overall heat transfer coefficient of the end walls (gables) of the attic space, Btuh.

UCELNG: Overall heat transfer coefficient of the ceiling under the attic, Btuh.

AENDW: Area of the attic end walls, sq. ft.

ATCHT: Attic space height, ft.

ARCHGA: Air change per hr. for attic.

AIRNT: Nighttime air change multiplier with respect to ARCHGA.

| UENDW | UCELNG | AENDW | ATCHT | ARCHGA | AIRNT | | | | |
|-------|--------|-------|-------|--------|-------|--|--|--|--|
| | | | | | | | | | |

* This data sheet provides information for the attic space with a flat roof. If gabled roof, it must be treated as an equivalent flat roof.

Data Sheet 16

IEXTED: Exterior shading control index:

IEXTED = 1 if the exterior shading device is controlled to cut down the direct solar heat gain.

IEXTED = 0 if the exterior shading device is not controlled.

IEXMS: The month at which the exterior shading device control starts.

IEXME: The month at which the exterior shading device control ends.

NTVNT: Ventilation air change per hour during the unoccupied period to precool the building. The ventilation system is assumed on only during the cooling season when

- a. The room temperature exceeds 75 °F.
- b. Outdoor temperature is below 70 °F.

NVENT: Natural ventilation index

NVENT = 1 if outdoor air is brought in during the occupied period to minimize the cooling load.

NVENT = 0 otherwise.

(integer data)

| | | | | | | | | | |
|--------|-------|-------|-------|-------|--|--|--|--|--|
| IEXTED | IEXMS | IEXME | NTVNT | NVENT | | | | | |
| | | | | | | | | | |

Run Sequence

The step by step procedure to perform the heating and cooling load calculation by using NBSLD on the INFONET system is as follows:

1. Complete the data forms described in this manual.
2. Check the data for probable errors.
3. Turn the computer terminal on.
4. Dial the computer center and listen to the high-pitched tone.
5. Place the telephone receiver onto the acoustic coupler of the terminal.
6. Hit the key "T".

The computer responds with

"PORT:" Port number

"CENTER:"

Type in after "CENTER:" BB

The computer responds then with

"LOGON:"

Type in your identification number after "LOGON:".

7. The computer then returns the carriage of the terminal and types!
8. Every time the computer waits for your command, it responds with ! at the first position of the carriage. Following in the sequence of the commands needed to perform the load calculations.

! EDIT NBSBLI

↑ 1

2

60

61

↑ Q

SRU'S: .9

! EQUATE 7 WETDAT

! EQUATE 9 SPACE 1

! EQUATE 10 SPACE 2

Type in the data from your data forms as illustrated in Figure C1.

... all the data are completed.

close the data file.

computer time unit used in the data preparation.

Weather tape file name.

Output tape No. 1.

Output tape No. 2.

9. Instruction for the terminal data input

Type in the following terminal data:

RUNID, RUNTYP, ASHRAE, IDETAL, METHOD

At this point, the computer starts the load calculation and output such as shown in P103 will be typed out on the terminal.

Weather Tape Handling

The use of Weather Data Tape 1440 provided by the National Climatic Center may be made as follows:

1. Request the tape containing data for specified years from the National Climatic Center

G. McKay or D. Calloway
Environmental Data Services
Asheville, North Carolina 28801
Telephone: (704) 254-0961

Remember that beginning January 1, 1965 a new program was initiated for most Weather Bureau Stations reducing the number of hourly observations being recorded from 24 to 8 per day. This format is not compatible with NBSLD as it is presently written since it requires hourly weather data. Note that the tape is 7 channel, 556 BPI density and of even parity.

2. Have the tape mailed to INFONET computing center at the following address:

Mr. K. Walls
Center 1
INFONET Division
Computer Science Corporation
650 North Sepulveda Blvd.
El Segundo, California 90245

3. Ask INFONET to assign a Volume number such as US001.
4. The tape 1440 is then decoded and stored into a weather data file name of which may be obtained by the following INFONET commands:

```
! DEVICES, QUEUE 0,0,1
```

```
! EQUATE 9 WETDAT
```

```
! WETHER
```

```
VOL, DENS, PARITY, TRACK
```

VOL: Tape name.

DENS: Tape density in BPI.

PARITY: Data parity, either even or odd.

TRACK: Track number, either 7 or 9.

```
ISKIP, NDAY, IWRITE ... data
```

where ISKIP: Number of days to be skipped from the
beginning of the tape.

NDAY: Number of days for which the weather
data are to be stored in the file.

IWRITE = 1: if the weather data are to be printed
out on the terminal as they are pro-
cessed and stored; otherwise zero.

5. The constants of WETDAT may be checked by a separate routine
WETAP by

```
! EQUATE 9 WETDAT
```

```
! WETAP
```

```
NDAY, NSKIP
```

where NDAY: Number of days for which the weather data
are to be displayed on the terminal.

NSKIP: Number of days to be skipped from the be-
ginning of the file WETDAT.

When the use is made of WETDAT in any other program, it can be read in the Fortran program as follows:

```
READ(9) DB, DP, WB, WS, PB, TC, NTOC, DAY, IYEAR, MONTH, ICITY
```

where DB, DD, WB, WS, PB, TC, and NTOC are all dimensioned 24 and represent respectively dry-bulb temperature, dewpoint temperature, wet-bulb temperature, wind speed, barometric pressure, total cloud amount, and type of cloud.

Table C1

Design Weather Data

Reprinted by permission from the 1972 Handbook of Fundamentals, (American Society of Heating, Refrigerating and Air-Conditioning Engineers, 345 East 47th Street, New York), pp. 669-687.

Climatic Conditions for United States and Canada*^a

| Col. 1 State and Station ^b | Col. 2 Latitude ^c | Col. 3 Elev. ^d Ft | Winter | | | | Summer | | | | | | |
|--|---------------------------------|------------------------------------|---|-----|------|---|---------------------------|-----|-----|---|---------------------------|-----|----|
| | | | Col. 4 | | | Col. 5 Coincident Wind Velocity ^e | Col. 6 Design Dry-Bulb | | | Col. 7 Out- door Daily Range ^f | Col. 8 Design Wet-Bulb | | |
| | | | Median of Annual Ex- tremes | 99% | 97½% | | 1% | 2½% | 5% | | 1% | 2½% | 5% |
| ALABAMA | | | | | | | | | | | | | |
| Alexander City..... | 33 0 | 660 | 12 | 16 | 20 | L | 96 | 94 | 93 | 21 | 79 | 78 | 77 |
| Anniston AP..... | 33 4 | 599 | 12 | 17 | 19 | L | 96 | 94 | 93 | 21 | 79 | 78 | 77 |
| Auburn..... | 32 4 | 730 | 17 | 21 | 25 | L | 98 | 96 | 95 | 21 | 80 | 79 | 78 |
| Birmingham AP..... | 33 3 | 610 | 14 | 19 | 22 | L | 97 | 94 | 93 | 21 | 79 | 78 | 77 |
| Decatur..... | 34 4 | 580 | 10 | 15 | 19 | L | 97 | 95 | 94 | 22 | 79 | 78 | 77 |
| | | | | | | | | | | | | | |
| Dothan AP..... | 31 2 | 321 | 19 | 23 | 27 | L | 97 | 95 | 94 | 20 | 81 | 80 | 79 |
| Florence AP..... | 34 5 | 528 | 8 | 13 | 17 | L | 97 | 95 | 94 | 22 | 79 | 78 | 77 |
| Gadsden..... | 34 0 | 570 | 11 | 16 | 20 | L | 96 | 94 | 93 | 22 | 78 | 77 | 76 |
| Huntsville AP..... | 34 4 | 619 | -6 | 13 | 17 | L | 97 | 95 | 94 | 23 | 78 | 77 | 76 |
| Mobile AP..... | 30 4 | 211 | 21 | 26 | 29 | M | 95 | 93 | 91 | 18 | 80 | 79 | 79 |
| | | | | | | | | | | | | | |
| Mobile CO..... | 30 4 | 119 | 24 | 28 | 32 | M | 96 | 94 | 93 | 16 | 80 | 79 | 79 |
| Montgomery AP..... | 32 2 | 195 | 18 | 22 | 26 | L | 98 | 95 | 93 | 21 | 80 | 79 | 78 |
| Selma-Craig AFB..... | 32 2 | 207 | 18 | 23 | 27 | L | 98 | 96 | 94 | 21 | 81 | 80 | 79 |
| Talladega..... | 33 3 | 565 | 11 | 15 | 19 | L | 97 | 95 | 94 | 21 | 79 | 78 | 77 |
| Tuscaloosa AP..... | 33 1 | 170r | 14 | 19 | 23 | L | 98 | 96 | 95 | 22 | 81 | 80 | 79 |
| ALASKA | | | | | | | | | | | | | |
| Anchorage AP..... | 61 1 | 90 | -29 | -25 | -20 | VL | 73 | 70 | 67 | 15 | 63 | 61 | 59 |
| Barrow..... | 71 2 | 22 | -49 | -45 | -42 | M | 58 | 54 | 50 | 12 | 54 | 51 | 48 |
| Fairbanks AP..... | 64 5 | 436 | -59 | -53 | -50 | VL | 82 | 78 | 75 | 24 | 64 | 63 | 61 |
| Juneau AP..... | 58 2 | 17 | -11 | -7 | -4 | L | 75 | 71 | 68 | 15 | 66 | 64 | 62 |
| Kodiak..... | 57 3 | 21 | 4 | 8 | 12 | M | 71 | 66 | 63 | 10 | 62 | 60 | 58 |
| Nome AP..... | 64 3 | 13 | -37 | -32 | -28 | L | 66 | 62 | 59 | 10 | 58 | 56 | 54 |
| ARIZONA† | | | | | | | | | | | | | |
| Douglas AP..... | 31 3 | 4098 | 13 | 18 | 22 | VL | 100 | 98 | 96 | 31 | 70 | 69 | 68 |
| Flagstaff AP..... | 35 1 | 6973 | -10 | 0 | 5 | VL | 84 | 82 | 80 | 31 | 61 | 60 | 59 |
| Fort Huachuca AP..... | 31 3 | 4664 | 18 | 25 | 28 | VL | 95 | 93 | 91 | 27 | 69 | 68 | 67 |
| Kingman AP..... | 35 2 | 3446 | 18 | 25 | 29 | VL | 103 | 100 | 97 | 30 | 70 | 69 | 69 |
| Nogales..... | 31 2 | 3800 | 15 | 20 | 24 | VL | 100 | 98 | 96 | 31 | 72 | 71 | 70 |
| | | | | | | | | | | | | | |
| Phoenix AP..... | 33 3 | 1117 | 25 | 31 | 34 | VL | 108 | 106 | 104 | 27 | 77 | 76 | 75 |
| Prescott AP..... | 34 4 | 5014 | 7 | 15 | 19 | VL | 96 | 94 | 91 | 30 | 67 | 66 | 65 |
| Tucson AP..... | 33 1 | 2584 | 23 | 29 | 32 | VL | 105 | 102 | 100 | 26 | 74 | 73 | 72 |
| Winslow AP..... | 35 0 | 4880 | 2 | 9 | 13 | VL | 97 | 95 | 92 | 32 | 66 | 65 | 64 |
| Yuma AP..... | 32 4 | 199 | 32 | 37 | 40 | VL | 111 | 109 | 107 | 27 | 79 | 78 | 77 |
| ARKANSAS | | | | | | | | | | | | | |
| Blytheville AFB..... | 36 0 | 264 | 6 | 12 | 17 | L | 98 | 96 | 93 | 21 | 80 | 79 | 78 |
| Camden..... | 33 4 | 116 | 13 | 19 | 23 | L | 99 | 97 | 96 | 21 | 81 | 80 | 79 |
| El Dorado AP..... | 33 1 | 252 | 13 | 19 | 23 | L | 98 | 96 | 95 | 21 | 81 | 80 | 79 |
| Fayetteville AP..... | 36 0 | 1253 | 3 | 9 | 13 | M | 97 | 95 | 93 | 23 | 77 | 76 | 75 |
| Fort Smith AP..... | 35 2 | 449 | 9 | 15 | 19 | M | 101 | 99 | 96 | 24 | 79 | 78 | 77 |
| | | | | | | | | | | | | | |
| Hot Springs Nat. Pk..... | 34 3 | 710 | 12 | 18 | 22 | M | 99 | 97 | 96 | 22 | 79 | 78 | 77 |
| Jonesboro..... | 35 5 | 345 | 8 | 14 | 18 | M | 98 | 96 | 95 | 21 | 80 | 79 | 78 |
| Little Rock AP..... | 34 4 | 257 | 13 | 19 | 23 | M | 99 | 96 | 94 | 22 | 80 | 79 | 78 |
| Pine Bluff AP..... | 34 1 | 204 | 14 | 20 | 24 | L | 99 | 96 | 95 | 22 | 81 | 80 | 79 |
| Texarkana AP..... | 33 3 | 361 | 16 | 22 | 26 | M | 99 | 97 | 96 | 21 | 80 | 79 | 78 |
| CALIFORNIA† | | | | | | | | | | | | | |
| Bakersfield AP..... | 35 2 | 495 | 26 | 31 | 33 | VL | 103 | 101 | 99 | 32 | 72 | 71 | 70 |
| Barstow AP..... | 34 5 | 2142 | 18 | 24 | 28 | VL | 104 | 102 | 99 | 37 | 73 | 72 | 71 |
| Blythe AP..... | 33 4 | 390 | 26 | 31 | 35 | VL | 111 | 109 | 106 | 28 | 78 | 77 | 76 |
| Burbank AP..... | 34 1 | 699 | 30 | 36 | 38 | VL | 97 | 94 | 91 | 25 | 72 | 70 | 69 |
| Chico..... | 39 5 | 205 | 23 | 29 | 33 | VL | 102 | 100 | 97 | 36 | 71 | 70 | 69 |
| Concord..... | 38 0 | 195 | 27 | 32 | 36 | VL | 96 | 92 | 88 | 32 | 69 | 67 | 66 |

* Data for U. S. stations extracted from *Evaluated Weather Data for Cooling Equipment Design, Addendum No. 1, Winter and Summer Data*, with the permission of the publisher, Fluor Products Company, Inc., Box 1267, Santa Rosa, California.

^a Data compiled from official weather stations, where hourly weather observations are made by trained observers, and from other sources. Table 1 prepared by ASHRAE Technical Committee 2.2, *Weather Data and Design Conditions*. Percentage of winter design data show the percent of 3-month period, December through February. Canadian data are based on January only. Percentage of summer design data show the percent of 4-month period, June through September. Canadian data are based on July only. Also see References 1 to 7.

^b When airport temperature observations were used to develop design data, "AP" follows station name, and "AFB" follows Air Force Bases. Data for stations followed by "CO" came from office locations within an urban area and generally reflect an influence of the surrounding area. Stations without designation can be considered semirural and may be directly compared with most airport data.

^c Latitude is given to the nearest 10 minutes, for use in calculating solar loads. For example, the latitude for Anniston, Alabama is given as 33 4, or 33°40'.

^d Elevations are ground elevations for each station as of 1964. Temperature readings are generally made at an elevation of 5 ft above ground, except for locations marked r, indicating roof exposure of thermometer.

^e Coincident wind velocities derived from approximately coldest 600 hours out of 20,000 hours of December through February data per station. Also see References 5 and 6. The four classifications are:
 VL = Very Light, 70 percent or more of cold extreme hours ≤ 7 mph. M = Moderate, 50 to 74 percent cold extreme hours > 7 mph.
 L = Light, 50 to 69 percent cold extreme hours ≤ 7 mph. H = High, 75 percent or more cold extreme hours > 7 mph, and 50 percent are > 12 mph.

^f The difference between the average maximum and average minimum temperatures during the warmest month.

† More detailed data on Arizona, California, and Nevada may be found in *Recommended Design Temperatures, Northern California*, published by the Golden Gate Chapter; and *Recommended Design Temperatures, Southern California, Arizona, Nevada*, published by the Southern California Chapter.

Climatic Conditions for United States and Canada (Continued)*,a

| Col. 1 State and Station ^b | Col. 2 Latitude ^c | Col. 3 Elev. ^d ft | Winter | | | | Summer | | | | | | |
|--|---------------------------------|------------------------------------|---|-----|------|---|---------------------------|-----|-----|---|---------------------------|-----|----|
| | | | Col. 4 | | | Col. 5 Coincident Wind Velocity ^e | Col. 6 Design Dry-Bulb | | | Col. 7 Out- door Daily Range ^f | Col. 8 Design Wet-Bulb | | |
| | | | Median of Annual Ex- tremes | 99% | 97½% | | 1% | 2½% | 5% | | 1% | 2½% | 5% |
| | | | | | | | | | | | | | |
| CALIFORNIA† (continued) | | | | | | | | | | | | | |
| Covina..... | 34 0 | 575 | 32 | 38 | 41 | VL | 100 | 97 | 94 | 31 | 73 | 72 | 71 |
| Crescent City AP..... | 41 5 | 50 | 28 | 33 | 36 | L | 72 | 69 | 65 | 18 | 61 | 60 | 59 |
| Downey..... | 34 0 | 116 | 30 | 35 | 38 | VL | 93 | 90 | 87 | 22 | 72 | 71 | 70 |
| El Cajon..... | 32 4 | 525 | 26 | 31 | 34 | VL | 98 | 95 | 92 | 30 | 74 | 73 | 72 |
| El Centro AP..... | 32 5 | -30 | 26 | 31 | 35 | VL | 111 | 109 | 106 | 34 | 81 | 80 | 79 |
| Escondido..... | 33 0 | 660 | 28 | 33 | 36 | VL | 95 | 92 | 89 | 30 | 73 | 72 | 71 |
| Eureka/Arcata AP..... | 41 0 | 217 | 27 | 32 | 35 | L | 67 | 65 | 63 | 11 | 60 | 59 | 58 |
| Fairfield-Travis AFB..... | 38 2 | 72 | 26 | 32 | 34 | VL | 98 | 94 | 90 | 34 | 71 | 69 | 67 |
| Fresno AP..... | 36 5 | 326 | 25 | 28 | 31 | VL | 101 | 99 | 97 | 34 | 73 | 72 | 71 |
| Hamilton AFB..... | 38 0 | 3 | 28 | 33 | 35 | VL | 89 | 85 | 81 | 28 | 71 | 68 | 66 |
| Laguna Beach..... | 33 3 | 35 | 32 | 37 | 39 | VL | 83 | 80 | 77 | 18 | 69 | 68 | 67 |
| Livermore..... | 37 4 | 545 | 23 | 28 | 30 | VL | 99 | 97 | 94 | 24 | 70 | 69 | 68 |
| Lompoc, Vandenberg AFB..... | 34 4 | 552 | 32 | 36 | 38 | VL | 82 | 79 | 76 | 20 | 65 | 63 | 61 |
| Long Beach AP..... | 33 5 | 34 | 31 | 36 | 38 | VL | 87 | 84 | 81 | 22 | 72 | 70 | 69 |
| Los Angeles AP..... | 34 0 | 99 | 36 | 41 | 43 | VL | 86 | 83 | 80 | 15 | 69 | 68 | 67 |
| Los Angeles CO..... | 34 0 | 312 | 38 | 42 | 44 | VL | 94 | 90 | 87 | 20 | 72 | 70 | 69 |
| Merced-Castle AFB..... | 37 2 | 178 | 24 | 30 | 32 | VL | 102 | 99 | 96 | 36 | 73 | 72 | 70 |
| Modesto..... | 37 4 | 91 | 26 | 32 | 36 | VL | 101 | 98 | 96 | 36 | 72 | 71 | 70 |
| Monterey..... | 36 4 | 38 | 29 | 34 | 37 | VL | 82 | 79 | 76 | 20 | 64 | 63 | 61 |
| Napa..... | 38 2 | 16 | 26 | 31 | 34 | VL | 94 | 92 | 89 | 30 | 69 | 68 | 67 |
| Needles AP..... | 34 5 | 913 | 27 | 33 | 37 | VL | 112 | 110 | 107 | 27 | 76 | 75 | 74 |
| Oakland AP..... | 37 4 | 3 | 30 | 35 | 37 | VL | 85 | 81 | 77 | 19 | 65 | 63 | 62 |
| Oceanside..... | 33 1 | 30 | 33 | 38 | 40 | VL | 84 | 81 | 78 | 13 | 69 | 68 | 67 |
| Ontario..... | 34 0 | 995 | 26 | 32 | 34 | VL | 100 | 97 | 94 | 36 | 72 | 71 | 70 |
| Oxnard AFB..... | 34 1 | 43 | 32 | 35 | 37 | VL | 84 | 80 | 78 | 19 | 70 | 69 | 67 |
| Palmdale AP..... | 34 4 | 2517 | 18 | 24 | 27 | VL | 103 | 101 | 98 | 35 | 70 | 68 | 67 |
| Palm Springs..... | 33 5 | 411 | 27 | 32 | 36 | VL | 110 | 108 | 105 | 35 | 79 | 78 | 77 |
| Pasadena..... | 34 1 | 864 | 31 | 36 | 39 | VL | 96 | 93 | 90 | 29 | 72 | 70 | 69 |
| Petaluma..... | 38 1 | 27 | 24 | 29 | 32 | VL | 94 | 90 | 87 | 31 | 70 | 68 | 67 |
| Pomona CO..... | 34 0 | 871 | 26 | 31 | 34 | VL | 99 | 96 | 93 | 36 | 73 | 72 | 71 |
| Redding AP..... | 40 3 | 495 | 25 | 31 | 35 | VL | 103 | 101 | 98 | 32 | 70 | 69 | 67 |
| Redlands..... | 34 0 | 1318 | 28 | 34 | 37 | VL | 99 | 96 | 93 | 33 | 72 | 71 | 70 |
| Richmond..... | 38 0 | 55 | 28 | 35 | 38 | VL | 85 | 81 | 77 | 17 | 66 | 64 | 63 |
| Riverside-March AFB..... | 33 5 | 1511 | 26 | 32 | 34 | VL | 99 | 96 | 94 | 37 | 72 | 71 | 69 |
| Sacramento AP..... | 38 3 | 17 | 24 | 30 | 32 | VL | 100 | 97 | 94 | 36 | 72 | 70 | 69 |
| Salinas AP..... | 36 4 | 74 | 27 | 32 | 35 | VL | 87 | 85 | 82 | 24 | 67 | 65 | 64 |
| San Bernardino, Norton AFB..... | 34 1 | 1125 | 26 | 31 | 33 | VL | 101 | 98 | 96 | 38 | 75 | 73 | 71 |
| San Diego AP..... | 32 4 | 19 | 38 | 42 | 44 | VL | 86 | 83 | 80 | 12 | 71 | 70 | 68 |
| San Fernando..... | 34 1 | 977 | 29 | 34 | 37 | VL | 100 | 97 | 94 | 38 | 73 | 72 | 71 |
| San Francisco AP..... | 37 4 | 8 | 32 | 35 | 37 | L | 83 | 79 | 75 | 20 | 65 | 63 | 62 |
| San Francisco CO..... | 37 5 | 52 | 38 | 42 | 44 | VL | 80 | 77 | 73 | 14 | 64 | 62 | 61 |
| San Jose AP..... | 37 2 | 70r | 30 | 34 | 36 | VL | 90 | 88 | 85 | 26 | 69 | 67 | 65 |
| San Luis Obispo..... | 35 2 | 315 | 30 | 35 | 37 | VL | 89 | 85 | 82 | 26 | 65 | 64 | 63 |
| Santa Ana AP..... | 33 4 | 115r | 28 | 33 | 36 | VL | 92 | 89 | 86 | 23 | 72 | 71 | 70 |
| Santa Barbara CO..... | 34 3 | 100 | 30 | 34 | 36 | VL | 87 | 84 | 81 | 24 | 67 | 66 | 65 |
| Santa Cruz..... | 37 0 | 125 | 28 | 32 | 34 | VL | 87 | 84 | 80 | 28 | 66 | 65 | 63 |
| Santa Maria AP..... | 34 5 | 238 | 28 | 32 | 34 | VL | 85 | 82 | 79 | 23 | 65 | 64 | 63 |
| Santa Monica CO..... | 34 0 | 57 | 38 | 43 | 45 | VL | 80 | 77 | 74 | 16 | 69 | 68 | 67 |
| Santa Paula..... | 34 2 | 263 | 28 | 33 | 36 | VL | 91 | 89 | 86 | 36 | 72 | 71 | 70 |
| Santa Rosa..... | 38 3 | 167 | 24 | 29 | 32 | VL | 95 | 93 | 90 | 34 | 70 | 68 | 67 |
| Stockton AP..... | 37 5 | 28 | 25 | 30 | 34 | VL | 101 | 98 | 96 | 37 | 72 | 70 | 69 |
| Ukiah..... | 39 1 | 620 | 22 | 27 | 30 | VL | 98 | 96 | 93 | 40 | 70 | 69 | 67 |
| Visalia..... | 36 2 | 354 | 26 | 32 | 36 | VL | 102 | 100 | 97 | 38 | 73 | 72 | 70 |
| Yreka..... | 41 4 | 2625 | 7 | 13 | 17 | VL | 96 | 94 | 91 | 38 | 68 | 66 | 65 |
| Yuba City..... | 39 1 | 70 | 24 | 30 | 34 | VL | 102 | 100 | 97 | 36 | 71 | 70 | 69 |
| COLORADO | | | | | | | | | | | | | |
| Alamosa AP..... | 37 3 | 7536 | -26 | -17 | -13 | VL | 84 | 82 | 79 | 35 | 62 | 61 | 60 |
| Boulder..... | 40 0 | 5385 | -5 | 4 | 8 | L | 92 | 90 | 87 | 27 | 64 | 63 | 62 |
| Colorado Springs AP..... | 38 5 | 6173 | -9 | -1 | 4 | L | 90 | 88 | 86 | 30 | 63 | 62 | 61 |
| Denver AP..... | 39 5 | 5283 | -9 | -2 | 3 | L | 92 | 90 | 89 | 28 | 65 | 64 | 63 |
| Durango..... | 37 1 | 6550 | -10 | 0 | 4 | VL | 88 | 86 | 83 | 30 | 64 | 63 | 62 |

Climatic Conditions for United States and Canada (Continued)*, a

| Col. 1 State and Station ^b | Col. 2 Latitude ^c | Col. 3 Elev. ^d Ft | Winter | | | | Summer | | | | | | |
|--|---------------------------------|------------------------------------|---|-----|------|---|---------------------------|-----|----|---|---------------------------|-----|----|
| | | | Col. 4 | | | Col. 5 Coincident Wind Velocity ^e | Col. 6 Design Dry-Bulb | | | Col. 7 Out- door Daily Range ^f | Col. 8 Design Wet-Bulb | | |
| | | | Median of Annual Ex- tremes | 99% | 97½% | | 1% | 2½% | 5% | | 1% | 2½% | 5% |
| COLORADO (continued) | | | | | | | | | | | | | |
| Fort Collins..... | 40 4 | 5001 | -18 | - 9 | - 5 | L | 91 | 89 | 86 | 28 | 63 | 62 | 61 |
| Grand Junction AP..... | 39 1 | 4849 | - 2 | 8 | 11 | VL | 96 | 94 | 92 | 29 | 64 | 63 | 62 |
| Greeley..... | 40 3 | 4648 | -18 | - 9 | - 5 | L | 94 | 92 | 89 | 29 | 65 | 64 | 63 |
| La Junta AP..... | 38 0 | 4188 | -14 | - 6 | - 2 | M | 97 | 95 | 93 | 31 | 72 | 71 | 69 |
| Leadville..... | 39 2 | 10177 | -18 | - 9 | - 4 | VL | 76 | 73 | 70 | 30 | 56 | 55 | 54 |
| Pueblo AP..... | 38 2 | 4639 | -14 | - 5 | - 1 | L | 96 | 94 | 92 | 31 | 68 | 67 | 66 |
| Sterling..... | 40 4 | 3939 | -15 | - 6 | - 2 | M | 95 | 93 | 90 | 30 | 67 | 66 | 65 |
| Trinidad AP..... | 37 2 | 5746 | - 9 | 1 | 5 | L | 93 | 91 | 89 | 32 | 66 | 65 | 64 |
| CONNECTICUT | | | | | | | | | | | | | |
| Bridgeport AP..... | 41 1 | 7 | - 1 | 4 | 8 | M | 90 | 88 | 85 | 18 | 77 | 76 | 75 |
| Hartford, Brainard Field..... | 41 5 | 15 | - 4 | 1 | 5 | M | 90 | 88 | 85 | 22 | 77 | 76 | 74 |
| New Haven AP..... | 41 2 | 6 | 0 | 5 | 9 | H | 88 | 86 | 83 | 17 | 77 | 76 | 75 |
| New London..... | 41 2 | 60 | 0 | 4 | 8 | H | 89 | 86 | 83 | 16 | 77 | 75 | 74 |
| Norwalk..... | 41 1 | 37 | - 5 | 0 | 4 | M | 91 | 89 | 86 | 19 | 77 | 76 | 75 |
| Norwich..... | 41 3 | 20 | - 7 | - 2 | 2 | M | 88 | 86 | 83 | 18 | 77 | 76 | 75 |
| Waterbury..... | 41 3 | 605 | - 5 | 0 | 4 | M | 90 | 88 | 85 | 21 | 77 | 76 | 75 |
| Windsor Locks, Bradley Field..... | 42 0 | 169 | - 7 | - 2 | 2 | M | 90 | 88 | 85 | 22 | 76 | 75 | 73 |
| DELAWARE | | | | | | | | | | | | | |
| Dover AFB..... | 39 0 | 38 | 8 | 13 | 15 | M | 93 | 90 | 88 | 18 | 79 | 78 | 77 |
| Wilmington AP..... | 39 4 | 78 | 6 | 12 | 15 | M | 93 | 90 | 87 | 20 | 79 | 77 | 76 |
| DISTRICT OF COLUMBIA | | | | | | | | | | | | | |
| Andrews AFB..... | 38 5 | 279 | 9 | 13 | 16 | M | 94 | 91 | 88 | 18 | 79 | 77 | 76 |
| Washington National AP..... | 38 5 | 14 | 12 | 16 | 19 | M | 94 | 92 | 90 | 18 | 78 | 77 | 76 |
| FLORIDA | | | | | | | | | | | | | |
| Belle Glade..... | 26 4 | 16 | 31 | 35 | 39 | M | 93 | 91 | 90 | 16 | 80 | 79 | 79 |
| Cape Kennedy AP..... | 28 1 | 16 | 33 | 37 | 40 | L | 90 | 89 | 88 | 15 | 81 | 80 | 79 |
| Daytona Beach AP..... | 29 1 | 31 | 28 | 32 | 36 | L | 94 | 92 | 91 | 15 | 81 | 80 | 79 |
| Fort Lauderdale..... | 26 0 | 13 | 37 | 41 | 45 | M | 91 | 90 | 89 | 15 | 81 | 80 | 79 |
| Fort Myers AP..... | 26 4 | 13 | 34 | 38 | 42 | M | 94 | 92 | 91 | 18 | 80 | 80 | 79 |
| Fort Pierce..... | 27 3 | 10 | 33 | 37 | 41 | M | 93 | 91 | 90 | 15 | 81 | 80 | 79 |
| Gainesville AP..... | 29 4 | 155 | 24 | 28 | 32 | L | 96 | 94 | 93 | 18 | 80 | 79 | 79 |
| Jacksonville AP..... | 30 3 | 24 | 26 | 29 | 32 | L | 96 | 94 | 92 | 19 | 80 | 79 | 79 |
| Key West AP..... | 24 3 | 6 | 50 | 55 | 58 | M | 90 | 89 | 88 | 9 | 80 | 79 | 79 |
| Lakeland CO..... | 28 0 | 214 | 31 | 35 | 39 | M | 95 | 93 | 91 | 17 | 80 | 79 | 78 |
| Miami AP..... | 25 5 | 7 | 39 | 44 | 47 | M | 92 | 90 | 89 | 15 | 80 | 79 | 79 |
| Miami Beach CO..... | 25 5 | 9 | 40 | 45 | 48 | M | 91 | 89 | 88 | 10 | 80 | 79 | 79 |
| Ocala..... | 29 1 | 86 | 25 | 29 | 33 | L | 96 | 94 | 93 | 18 | 80 | 79 | 79 |
| Orlando AP..... | 28 3 | 106r | 29 | 33 | 37 | L | 96 | 94 | 93 | 17 | 80 | 79 | 78 |
| Panama City, Tyndall AFB..... | 30 0 | 22 | 28 | 32 | 35 | M | 92 | 91 | 90 | 14 | 81 | 80 | 80 |
| Pensacola CO..... | 30 3 | 13 | 25 | 29 | 32 | M | 92 | 90 | 89 | 14 | 82 | 81 | 80 |
| St. Augustine..... | 29 5 | 15 | 27 | 31 | 35 | L | 94 | 92 | 90 | 16 | 81 | 80 | 79 |
| St. Petersburg..... | 28 0 | 35 | 35 | 39 | 42 | M | 93 | 91 | 90 | 16 | 81 | 80 | 79 |
| Sanford..... | 28 5 | 14 | 29 | 33 | 37 | L | 95 | 93 | 92 | 17 | 80 | 79 | 79 |
| Sarasota..... | 27 2 | 30 | 31 | 35 | 39 | M | 93 | 91 | 90 | 17 | 80 | 80 | 79 |
| Tallahassee AP..... | 30 2 | 58 | 21 | 25 | 29 | L | 96 | 94 | 93 | 19 | 80 | 79 | 79 |
| Tampa AP..... | 28 0 | 19 | 32 | 36 | 39 | M | 92 | 91 | 90 | 17 | 81 | 80 | 79 |
| West Palm Beach AP..... | 26 4 | 15 | 36 | 40 | 44 | M | 92 | 91 | 89 | 16 | 81 | 80 | 80 |
| GEORGIA | | | | | | | | | | | | | |
| Albany, Turner AFB..... | 31 3 | 224 | 21 | 26 | 30 | L | 98 | 96 | 94 | 20 | 80 | 79 | 78 |
| Americus..... | 32 0 | 476 | 18 | 22 | 25 | L | 98 | 96 | 93 | 20 | 80 | 79 | 78 |
| Athens..... | 34 0 | 700 | 12 | 17 | 21 | L | 96 | 94 | 91 | 21 | 78 | 77 | 76 |
| Atlanta AP..... | 33 4 | 1005 | 14 | 18 | 23 | H | 95 | 92 | 90 | 19 | 78 | 77 | 76 |
| Augusta AP..... | 33 2 | 143 | 17 | 20 | 23 | L | 98 | 95 | 93 | 19 | 80 | 79 | 78 |
| Brunswick..... | 31 1 | 14 | 24 | 27 | 31 | L | 97 | 95 | 92 | 18 | 81 | 80 | 79 |
| Columbus, Lawson AFB..... | 32 3 | 242 | 19 | 23 | 26 | L | 98 | 96 | 94 | 21 | 80 | 79 | 78 |
| Dalton..... | 34 5 | 720 | 10 | 15 | 19 | L | 97 | 95 | 92 | 22 | 78 | 77 | 76 |
| Dublin..... | 32 3 | 215 | 17 | 21 | 25 | L | 98 | 96 | 93 | 20 | 80 | 79 | 78 |
| Gainesville..... | 34 2 | 1254 | 11 | 16 | 20 | L | 94 | 92 | 89 | 21 | 78 | 77 | 76 |
| Griffin..... | 33 1 | 980 | 13 | 17 | 22 | L | 95 | 93 | 90 | 21 | 79 | 78 | 77 |
| La Grange..... | 33 0 | 715 | 12 | 16 | 20 | L | 96 | 94 | 92 | 21 | 79 | 78 | 77 |
| Macon AP..... | 32 4 | 356 | 18 | 23 | 27 | L | 98 | 96 | 94 | 22 | 80 | 79 | 78 |
| Marietta, Dobbins AFB..... | 34 0 | 1016 | 12 | 17 | 21 | L | 95 | 93 | 91 | 21 | 78 | 77 | 76 |

Climatic Conditions for United States and Canada (Continued)*.a

| Col. 1 State and Station ^b | Col. 2 Latitude ^c | Col. 3 Elev. ^d Ft | Winter | | | | Summer | | | | | | |
|--|---------------------------------|------------------------------------|---|-----|------|---|---------------------------|-----|----|---|---------------------------|-----|----|
| | | | Col. 4 | | | Col. 5 Coinci- dent Wind Ve- locity ^e | Col. 6 Design Dry-Bulb | | | Col. 7 Out- door Daily Range ^f | Col. 8 Design Wet-Bulb | | |
| | | | Median of Annual Ex- tremes | 99% | 97½% | | 1% | 2½% | 5% | | 1% | 2½% | 5% |
| | | | | | | | | | | | | | |
| GEORGIA (continued) | | | | | | | | | | | | | |
| Moultrie..... | 31 1 | 340 | 22 | 26 | 30 | L | 97 | 95 | 93 | 20 | 80 | 79 | 78 |
| Rome AP..... | 34 2 | 637 | 11 | 16 | 20 | L | 97 | 95 | 93 | 23 | 78 | 77 | 76 |
| Savannah-Travis AP..... | 32 1 | 52 | 21 | 24 | 27 | L | 96 | 94 | 92 | 20 | 81 | 80 | 79 |
| Valdosta-Moody AFB..... | 31 0 | 239 | 24 | 28 | 31 | L | 96 | 94 | 92 | 20 | 80 | 79 | 78 |
| Waycross..... | 31 2 | 140 | 20 | 24 | 28 | L | 97 | 95 | 93 | 20 | 80 | 79 | 78 |
| HAWAII | | | | | | | | | | | | | |
| Hilo AP..... | 19 4 | 31 | 56 | 59 | 61 | L | 85 | 83 | 82 | 15 | 74 | 73 | 72 |
| Honolulu AP..... | 21 2 | 7 | 58 | 60 | 62 | L | 87 | 85 | 84 | 12 | 75 | 74 | 73 |
| Kaneohe..... | 21 2 | 198 | 58 | 60 | 61 | L | 85 | 83 | 82 | 12 | 74 | 73 | 73 |
| Wahiawa..... | 21 3 | 215 | 57 | 59 | 61 | L | 86 | 84 | 83 | 14 | 75 | 74 | 73 |
| IDAHO | | | | | | | | | | | | | |
| Boise AP..... | 43 3 | 2842 | 0 | 4 | 10 | L | 96 | 93 | 91 | 31 | 68 | 66 | 65 |
| Burley..... | 42 3 | 4180 | - 5 | 4 | 8 | VL | 95 | 93 | 89 | 35 | 68 | 66 | 64 |
| Coeur d'Alene AP..... | 47 5 | 2973 | - 4 | 2 | 7 | VL | 94 | 91 | 88 | 31 | 66 | 65 | 63 |
| Idaho Falls AP..... | 43 3 | 4730r | -17 | -12 | - 6 | VL | 91 | 88 | 85 | 38 | 65 | 64 | 62 |
| Lewiston AP..... | 46 2 | 1413 | 1 | 6 | 12 | VL | 98 | 96 | 93 | 32 | 67 | 66 | 65 |
| Moscow..... | 46 4 | 2660 | -11 | - 3 | 1 | VL | 91 | 89 | 86 | 32 | 64 | 63 | 61 |
| Mountain Home AFB..... | 43 0 | 2992 | - 3 | 2 | 9 | L | 99 | 96 | 93 | 36 | 68 | 66 | 64 |
| Pocatello AP..... | 43 0 | 4444 | -12 | - 8 | - 2 | VL | 94 | 91 | 88 | 35 | 65 | 63 | 62 |
| Twin Falls AP..... | 42 3 | 4148 | - 5 | 4 | 8 | L | 96 | 94 | 91 | 34 | 66 | 64 | 63 |
| ILLINOIS | | | | | | | | | | | | | |
| Aurora..... | 41 5 | 744 | -13 | - 7 | - 3 | M | 93 | 91 | 88 | 20 | 78 | 77 | 75 |
| Belleville, Scott AFB..... | 38 3 | 447 | 0 | 6 | 10 | M | 97 | 95 | 92 | 21 | 79 | 78 | 77 |
| Bloomington..... | 40 3 | 775 | - 7 | - 1 | 3 | M | 94 | 92 | 89 | 21 | 79 | 78 | 77 |
| Carbondale..... | 37 5 | 380 | 1 | 7 | 11 | M | 98 | 96 | 94 | 21 | 80 | 79 | 78 |
| Champaign/Urbana..... | 40 0 | 743 | - 6 | 0 | 4 | M | 96 | 94 | 91 | 21 | 79 | 78 | 77 |
| Chicago, Midway AP..... | 41 5 | 610 | - 7 | - 4 | 1 | M | 95 | 92 | 89 | 20 | 78 | 76 | 75 |
| Chicago, O'Hare AP..... | 42 0 | 658 | - 9 | - 4 | 0 | M | 93 | 90 | 87 | 20 | 77 | 75 | 74 |
| Chicago, CO..... | 41 5 | 594 | - 5 | - 3 | 1 | M | 94 | 91 | 88 | 15 | 78 | 76 | 75 |
| Danville..... | 40 1 | 558 | - 6 | - 1 | 4 | M | 96 | 94 | 91 | 21 | 79 | 78 | 76 |
| Decatur..... | 39 5 | 670 | - 6 | 0 | 4 | M | 96 | 93 | 91 | 21 | 79 | 78 | 77 |
| Dixon..... | 41 5 | 696 | -13 | - 7 | - 3 | M | 93 | 91 | 89 | 23 | 78 | 77 | 76 |
| Elgin..... | 42 0 | 820 | -14 | - 8 | - 4 | M | 92 | 90 | 87 | 21 | 78 | 76 | 75 |
| Freeport..... | 42 2 | 780 | -16 | -10 | - 6 | M | 92 | 90 | 87 | 24 | 78 | 77 | 75 |
| Galesburg..... | 41 0 | 771 | -10 | - 4 | 0 | M | 95 | 92 | 89 | 22 | 79 | 78 | 76 |
| Greenville..... | 39 0 | 563 | - 3 | 3 | 7 | M | 96 | 94 | 92 | 21 | 79 | 78 | 77 |
| Joliet AP..... | 41 3 | 588 | -11 | - 5 | - 1 | M | 94 | 92 | 89 | 20 | 78 | 77 | 75 |
| Kankakee..... | 41 1 | 625 | -10 | - 4 | 1 | M | 94 | 92 | 89 | 21 | 78 | 77 | 76 |
| La Salle/Peru..... | 41 2 | 520 | - 9 | - 3 | 1 | M | 94 | 93 | 90 | 22 | 78 | 77 | 76 |
| Macomb..... | 40 3 | 702 | - 5 | - 3 | 1 | M | 95 | 93 | 90 | 22 | 79 | 78 | 77 |
| Moline AP..... | 41 3 | 582 | -12 | - 7 | - 3 | M | 94 | 91 | 88 | 23 | 79 | 77 | 76 |
| Mt. Vernon..... | 38 2 | 500 | 0 | 6 | 10 | M | 97 | 95 | 92 | 21 | 79 | 78 | 77 |
| Peoria AP..... | 40 4 | 652 | - 8 | - 2 | 2 | M | 94 | 92 | 89 | 22 | 78 | 77 | 76 |
| Quincy AP..... | 40 0 | 762 | - 8 | - 2 | 2 | M | 97 | 95 | 92 | 22 | 80 | 79 | 77 |
| Rantoul, Chanute AFB..... | 40 2 | 740 | - 7 | - 1 | 3 | M | 94 | 92 | 89 | 21 | 78 | 77 | 76 |
| Rockford..... | 42 1 | 724 | -13 | - 7 | - 3 | M | 92 | 90 | 87 | 24 | 77 | 76 | 75 |
| Springfield AP..... | 39 5 | 587 | - 7 | - 1 | 4 | M | 95 | 92 | 90 | 21 | 79 | 78 | 77 |
| Waukegan..... | 42 2 | 680 | -11 | - 5 | - 1 | M | 92 | 90 | 87 | 21 | 77 | 76 | 75 |
| INDIANA | | | | | | | | | | | | | |
| Anderson..... | 40 0 | 847 | - 5 | 0 | 5 | M | 93 | 91 | 88 | 22 | 78 | 77 | 76 |
| Bedford..... | 38 5 | 670 | - 3 | 3 | 7 | M | 95 | 93 | 90 | 22 | 79 | 78 | 77 |
| Bloomington..... | 39 1 | 820 | - 3 | 3 | 7 | M | 95 | 92 | 90 | 22 | 79 | 78 | 76 |
| Columbus, Bakalar AFB..... | 39 2 | 661 | - 3 | 3 | 7 | M | 95 | 92 | 90 | 22 | 79 | 78 | 76 |
| Crawfordsville..... | 40 0 | 752 | - 8 | - 2 | 2 | M | 95 | 93 | 90 | 22 | 79 | 77 | 76 |
| Evansville AP..... | 38 0 | 381 | 1 | 6 | 10 | M | 96 | 94 | 91 | 22 | 79 | 78 | 77 |
| Fort Wayne AP..... | 41 0 | 791 | - 5 | 0 | 5 | M | 93 | 91 | 88 | 24 | 77 | 76 | 75 |
| Goshen AP..... | 41 3 | 823 | -10 | - 4 | 0 | M | 92 | 90 | 87 | 23 | 77 | 76 | 74 |
| Hobart..... | 41 3 | 600 | -10 | - 4 | 0 | M | 93 | 91 | 88 | 21 | 78 | 76 | 75 |
| Huntington..... | 40 4 | 802 | - 8 | - 2 | 2 | M | 94 | 92 | 89 | 23 | 78 | 76 | 75 |
| Indianapolis AP..... | 39 4 | 793 | - 5 | 0 | 4 | M | 93 | 91 | 88 | 22 | 78 | 77 | 76 |
| Jeffersonville..... | 38 2 | 455 | 3 | 9 | 13 | M | 96 | 94 | 91 | 23 | 79 | 78 | 77 |
| Kokomo..... | 40 3 | 790 | - 6 | 0 | 4 | M | 94 | 92 | 89 | 22 | 78 | 76 | 75 |
| Lafayette..... | 40 2 | 600 | - 7 | - 1 | 3 | M | 94 | 92 | 89 | 22 | 78 | 77 | 76 |

Climatic Conditions for United States and Canada (Continued)*.a

| Col. 1 State and Station ^b | Col. 2 Latitude ^c | Col. 3 Elev. ^d ft | Winter | | | | Summer | | | | | | |
|--|---------------------------------|------------------------------------|---|-----|------|---|---------------------------|-----|----|---|---------------------------|-----|----|
| | | | Col. 4 | | | Col. 5 Coincident Wind Velocity ^e | Col. 6 Design Dry-Bulb | | | Col. 7 Out- door Daily Range ^f | Col. 8 Design Wet-Bulb | | |
| | | | Median of Annual Ex- tremes | 99% | 97½% | | 1% | 2½% | 5% | | 1% | 2½% | 5% |
| | | | | | | | | | | | | | |
| INDIANA (continued) | | | | | | | | | | | | | |
| La Porte..... | 41 3 | 810 | -10 | - 4 | 0 | M | 93 | 91 | 88 | 22 | 77 | 76 | 74 |
| Marion..... | 40 3 | 791 | - 8 | - 2 | 2 | M | 93 | 91 | 88 | 23 | 78 | 76 | 75 |
| Muncie..... | 40 1 | 955 | - 8 | - 2 | 2 | M | 93 | 91 | 88 | 22 | 78 | 77 | 75 |
| Peru, Bunker Hill AFB..... | 40 4 | 804 | - 9 | - 3 | 1 | M | 91 | 89 | 86 | 22 | 77 | 76 | 74 |
| Richmond AP..... | 39 5 | 1138 | - 7 | - 1 | 3 | M | 93 | 91 | 88 | 22 | 78 | 77 | 75 |
| Shelbyville..... | 39 3 | 765 | - 4 | 2 | 6 | M | 94 | 92 | 89 | 22 | 78 | 77 | 76 |
| South Bend AP..... | 41 4 | 773 | - 6 | - 2 | 3 | M | 92 | 89 | 87 | 22 | 77 | 76 | 74 |
| Terre Haute AP..... | 39 3 | 601 | - 3 | 3 | 7 | M | 95 | 93 | 91 | 22 | 79 | 78 | 77 |
| Valparaiso..... | 41 2 | 801 | -12 | - 6 | - 2 | M | 92 | 90 | 87 | 22 | 78 | 76 | 75 |
| Vincennes..... | 38 4 | 420 | - 1 | 5 | 9 | M | 96 | 94 | 91 | 22 | 79 | 78 | 77 |
| IOWA | | | | | | | | | | | | | |
| Ames..... | 42 0 | 1004 | -17 | -11 | - 7 | M | 94 | 92 | 89 | 23 | 79 | 78 | 76 |
| Burlington AP..... | 40 5 | 694 | -10 | - 4 | 0 | M | 95 | 92 | 89 | 22 | 80 | 78 | 77 |
| Cedar Rapids AP..... | 41 5 | 863 | -14 | - 8 | - 4 | M | 92 | 90 | 87 | 23 | 78 | 76 | 75 |
| Clinton..... | 41 5 | 595 | -13 | - 7 | - 3 | M | 92 | 90 | 87 | 23 | 78 | 77 | 76 |
| Council Bluffs..... | 41 2 | 1210 | -14 | - 7 | - 3 | M | 97 | 94 | 91 | 22 | 79 | 78 | 76 |
| Des Moines AP..... | 41 3 | 948r | -13 | - 7 | - 3 | M | 95 | 92 | 89 | 23 | 79 | 77 | 76 |
| Dubuque..... | 42 2 | 1065 | -17 | -11 | - 7 | M | 92 | 90 | 87 | 22 | 78 | 76 | 75 |
| Fort Dodge..... | 42 3 | 1111 | -18 | -12 | - 8 | M | 94 | 92 | 89 | 23 | 78 | 77 | 75 |
| Iowa City..... | 41 4 | 645 | -14 | - 8 | - 4 | M | 94 | 91 | 88 | 22 | 79 | 77 | 76 |
| Keokuk..... | 40 2 | 526 | - 9 | - 3 | 1 | M | 95 | 93 | 90 | 22 | 79 | 78 | 77 |
| Marshalltown..... | 42 0 | 898 | -16 | -10 | - 6 | M | 93 | 91 | 88 | 23 | 79 | 77 | 76 |
| Mason City AP..... | 43 1 | 1194 | -20 | -13 | - 9 | M | 91 | 88 | 85 | 24 | 77 | 75 | 74 |
| Newton..... | 41 4 | 946 | -15 | - 9 | - 5 | M | 95 | 93 | 90 | 23 | 79 | 77 | 76 |
| Ottumwa AP..... | 41 1 | 842 | -12 | - 6 | - 2 | M | 95 | 93 | 90 | 22 | 79 | 78 | 76 |
| Sioux City AP..... | 42 2 | 1095 | -17 | -10 | - 6 | M | 96 | 93 | 90 | 24 | 79 | 77 | 76 |
| Waterloo..... | 42 3 | 868 | -18 | -12 | - 8 | M | 91 | 89 | 86 | 23 | 78 | 76 | 75 |
| KANSAS | | | | | | | | | | | | | |
| Atchison..... | 39 3 | 945 | - 9 | - 2 | 2 | M | 97 | 95 | 92 | 23 | 79 | 78 | 77 |
| Chanute AP..... | 37 4 | 977 | - 3 | 3 | 7 | H | 99 | 97 | 95 | 23 | 79 | 78 | 77 |
| Dodge City AP..... | 37 5 | 2594 | - 5 | 3 | 7 | M | 99 | 97 | 95 | 25 | 74 | 73 | 72 |
| El Dorado..... | 37 5 | 1282 | - 3 | 4 | 8 | H | 101 | 99 | 96 | 24 | 78 | 77 | 76 |
| Emporia..... | 38 2 | 1209 | - 4 | 3 | 7 | H | 99 | 97 | 94 | 25 | 78 | 77 | 76 |
| Garden City AP..... | 38 0 | 2882 | -10 | - 1 | 3 | M | 100 | 98 | 96 | 28 | 74 | 73 | 72 |
| Goodland AP..... | 39 2 | 3645 | -10 | - 2 | 4 | M | 99 | 96 | 93 | 31 | 71 | 70 | 69 |
| Great Bend..... | 38 2 | 1940 | - 5 | 2 | 6 | M | 101 | 99 | 96 | 28 | 77 | 76 | 75 |
| Hutchinson AP..... | 38 0 | 1524 | - 5 | 2 | 6 | H | 101 | 99 | 96 | 28 | 77 | 76 | 75 |
| Liberal..... | 37 0 | 2838 | - 4 | 4 | 8 | M | 102 | 100 | 99 | 28 | 74 | 73 | 71 |
| Manhattan, Fort Riley..... | 39 0 | 1076 | - 7 | - 1 | 4 | H | 101 | 98 | 95 | 24 | 79 | 78 | 77 |
| Parsons..... | 37 2 | 908 | - 2 | 5 | 9 | H | 99 | 97 | 94 | 23 | 79 | 78 | 77 |
| Russell AP..... | 38 5 | 1864 | - 7 | 0 | 4 | M | 102 | 100 | 97 | 29 | 78 | 76 | 75 |
| Salina..... | 38 5 | 1271 | - 4 | 3 | 7 | H | 101 | 99 | 96 | 26 | 78 | 76 | 75 |
| Topeka AP..... | 39 0 | 877 | - 4 | 3 | 6 | M | 99 | 96 | 94 | 24 | 79 | 78 | 77 |
| Wichita AP..... | 37 4 | 1321 | - 1 | 5 | 9 | H | 102 | 99 | 96 | 23 | 77 | 76 | 75 |
| KENTUCKY | | | | | | | | | | | | | |
| Ashland..... | 38 3 | 551 | 1 | 6 | 10 | L | 94 | 92 | 89 | 22 | 77 | 76 | 75 |
| Bowling Green AP..... | 37 0 | 535 | 1 | 7 | 11 | L | 97 | 95 | 93 | 21 | 79 | 78 | 77 |
| Corbin AP..... | 37 0 | 1175 | 0 | 5 | 9 | L | 93 | 91 | 89 | 23 | 79 | 77 | 76 |
| Covington AP..... | 39 0 | 869 | - 3 | 3 | 8 | L | 93 | 90 | 88 | 22 | 77 | 76 | 75 |
| Hopkinsville, Campbell AFB..... | 36 4 | 540 | 4 | 10 | 14 | L | 97 | 95 | 92 | 21 | 79 | 78 | 77 |
| Lexington AP..... | 38 0 | 979 | 0 | 6 | 10 | M | 94 | 92 | 90 | 22 | 78 | 77 | 76 |
| Louisville AP..... | 38 1 | 474 | 1 | 8 | 12 | L | 96 | 93 | 91 | 23 | 79 | 78 | 77 |
| Madisonville..... | 37 2 | 439 | 1 | 7 | 11 | L | 96 | 94 | 92 | 22 | 79 | 78 | 77 |
| Owensboro..... | 37 5 | 420 | 0 | 6 | 10 | L | 96 | 94 | 92 | 23 | 79 | 78 | 77 |
| Paducah AP..... | 37 0 | 398 | 4 | 10 | 14 | L | 97 | 95 | 94 | 20 | 80 | 79 | 78 |
| LOUISIANA | | | | | | | | | | | | | |
| Alexandria AP..... | 31 2 | 92 | 20 | 25 | 29 | L | 97 | 95 | 94 | 20 | 80 | 80 | 79 |
| Baton Rouge AP..... | 30 3 | 64 | 22 | 25 | 30 | L | 96 | 94 | 92 | 19 | 81 | 80 | 79 |
| Bogalusa..... | 30 5 | 103 | 20 | 24 | 28 | L | 96 | 94 | 93 | 19 | 80 | 79 | 78 |
| Houma..... | 29 3 | 13 | 25 | 29 | 33 | L | 94 | 92 | 91 | 15 | 81 | 80 | 79 |
| Lafayette AP..... | 30 1 | 38 | 23 | 28 | 32 | L | 95 | 93 | 92 | 18 | 81 | 81 | 80 |
| Lake Charles AP..... | 30 1 | 14 | 25 | 29 | 33 | M | 95 | 93 | 91 | 17 | 80 | 79 | 79 |
| Minden..... | 32 4 | 250 | 17 | 22 | 26 | L | 98 | 96 | 95 | 20 | 81 | 80 | 79 |

Climatic Conditions for United States and Canada (Continued)*.a

| Col. 1 State and Station ^b | Col. 2 Latitude ^c | Col. 3 Elev., ^d Ft | Winter | | | | Summer | | | | | | |
|--|---------------------------------|-------------------------------------|---|-----|------|--|---------------------------|-----|----|---|---------------------------|-----|----|
| | | | Col. 4 | | | Col. 5 Coincident Wind Ve- locity ^e | Col. 6 Design Dry-Bulb | | | Col. 7 Out- door Daily Range ^f | Col. 8 Design Wet-Bulb | | |
| | | | Median of Annual Ex- tremes | 99% | 97½% | | 1% | 2½% | 5% | | 1% | 2½% | 5% |
| | | | | | | | | | | | | | |
| LOUISIANA (continued) | | | | | | | | | | | | | |
| Monroe AP..... | 32 3 | 78 | 18 | 23 | 27 | L | 98 | 96 | 95 | 20 | 81 | 81 | 80 |
| Natchitoches..... | 31 5 | 120 | 17 | 22 | 26 | L | 99 | 97 | 96 | 20 | 81 | 80 | 79 |
| New Orleans AP..... | 30 0 | 3 | 29 | 32 | 35 | M | 93 | 91 | 90 | 16 | 81 | 80 | 79 |
| Shreveport AP..... | 32 3 | 252 | 18 | 22 | 26 | M | 99 | 96 | 94 | 20 | 81 | 80 | 79 |
| MAINE | | | | | | | | | | | | | |
| Augusta AP..... | 44 2 | 350 | -13 | - 7 | - 3 | M | 88 | 86 | 83 | 22 | 74 | 73 | 71 |
| Bangor, Dow AFB..... | 44 5 | 162 | -14 | - 8 | - 4 | M | 88 | 85 | 81 | 22 | 75 | 73 | 71 |
| Caribou AP..... | 46 5 | 624 | -24 | -18 | -14 | L | 85 | 81 | 78 | 21 | 72 | 70 | 68 |
| Lewiston..... | 44 0 | 182 | -14 | - 8 | - 4 | M | 88 | 86 | 83 | 22 | 74 | 73 | 71 |
| Millinocket AP..... | 45 4 | 405 | -22 | -16 | -12 | L | 87 | 85 | 82 | 22 | 74 | 72 | 70 |
| Portland AP..... | 43 4 | 61 | -14 | - 5 | 0 | L | 88 | 85 | 81 | 22 | 75 | 73 | 71 |
| Waterville..... | 44 3 | 89 | -15 | - 9 | - 5 | M | 88 | 86 | 82 | 22 | 74 | 73 | 71 |
| MARYLAND | | | | | | | | | | | | | |
| Baltimore AP..... | 39 1 | 146 | 8 | 12 | 15 | M | 94 | 91 | 89 | 21 | 79 | 78 | 77 |
| Baltimore CO..... | 39 2 | 14 | 12 | 16 | 20 | M | 94 | 92 | 89 | 17 | 79 | 78 | 77 |
| Cumberland..... | 39 4 | 945 | 0 | 5 | 9 | L | 94 | 92 | 89 | 22 | 76 | 75 | 74 |
| Frederick AP..... | 39 2 | 294 | 2 | 7 | 11 | M | 94 | 92 | 89 | 22 | 78 | 77 | 76 |
| Hagerstown..... | 39 4 | 660 | 1 | 6 | 10 | L | 94 | 92 | 89 | 22 | 77 | 76 | 75 |
| Salisbury..... | 38 2 | 52 | 10 | 14 | 18 | M | 92 | 90 | 87 | 18 | 79 | 78 | 77 |
| MASSACHUSETTS | | | | | | | | | | | | | |
| Boston AP..... | 42 2 | 15 | - 1 | 6 | 10 | H | 91 | 88 | 85 | 16 | 76 | 74 | 73 |
| Clinton..... | 42 2 | 398 | - 8 | - 2 | 2 | M | 87 | 85 | 82 | 17 | 75 | 74 | 72 |
| Fall River..... | 41 4 | 190 | - 1 | 5 | 9 | H | 88 | 86 | 83 | 18 | 75 | 74 | 73 |
| Framingham..... | 42 2 | 170 | - 7 | - 1 | 3 | M | 91 | 89 | 86 | 17 | 76 | 74 | 73 |
| Gloucester..... | 42 3 | 10 | - 4 | 2 | 6 | H | 86 | 84 | 81 | 15 | 74 | 73 | 72 |
| Greenfield..... | 42 3 | 205 | -12 | - 6 | - 2 | M | 89 | 87 | 84 | 23 | 75 | 74 | 73 |
| Lawrence..... | 42 4 | 57 | - 9 | - 3 | 1 | M | 90 | 88 | 85 | 22 | 76 | 74 | 72 |
| Lowell..... | 42 3 | 90 | - 7 | - 1 | 3 | M | 91 | 89 | 86 | 21 | 76 | 74 | 72 |
| New Bedford..... | 41 4 | 70 | 3 | 9 | 13 | H | 86 | 84 | 81 | 19 | 75 | 73 | 72 |
| Pittsfield AP..... | 42 3 | 1170 | -11 | - 5 | - 1 | M | 86 | 84 | 81 | 23 | 74 | 72 | 71 |
| Springfield, Westover AFB..... | 42 1 | 247 | - 8 | - 3 | 2 | M | 91 | 88 | 85 | 19 | 76 | 74 | 73 |
| Taunton..... | 41 5 | 20 | - 9 | - 4 | 0 | H | 88 | 86 | 83 | 18 | 76 | 75 | 74 |
| Worcester AP..... | 42 2 | 986 | - 8 | - 3 | 1 | M | 89 | 87 | 84 | 18 | 75 | 73 | 71 |
| MICHIGAN | | | | | | | | | | | | | |
| Adrian..... | 41 5 | 754 | - 6 | 0 | 4 | M | 93 | 91 | 88 | 23 | 76 | 75 | 74 |
| Alpena AP..... | 45 0 | 689 | -11 | - 5 | - 1 | M | 87 | 85 | 82 | 27 | 74 | 73 | 71 |
| Battle Creek AP..... | 42 2 | 939 | - 6 | 1 | 5 | M | 92 | 89 | 86 | 23 | 76 | 74 | 73 |
| Benton Harbor AP..... | 42 1 | 649 | - 7 | - 1 | 3 | M | 90 | 88 | 85 | 20 | 76 | 74 | 73 |
| Detroit Met. CAP..... | 42 2 | 633 | 0 | 4 | 8 | M | 92 | 88 | 85 | 20 | 76 | 75 | 74 |
| Escanaba..... | 45 4 | 594 | -13 | - 7 | - 3 | M | 82 | 80 | 77 | 17 | 73 | 71 | 69 |
| Flint AP..... | 43 0 | 766 | - 7 | - 1 | 3 | M | 89 | 87 | 84 | 25 | 76 | 75 | 74 |
| Grand Rapids AP..... | 42 5 | 681 | - 3 | 2 | 6 | M | 91 | 89 | 86 | 24 | 76 | 74 | 73 |
| Holland..... | 42 5 | 612 | - 4 | 2 | 6 | M | 90 | 88 | 85 | 22 | 76 | 74 | 73 |
| Jackson AP..... | 42 2 | 1003 | - 6 | 0 | 4 | M | 92 | 89 | 86 | 23 | 76 | 75 | 74 |
| Kalamazoo..... | 42 1 | 930 | - 5 | 1 | 5 | M | 92 | 89 | 86 | 23 | 76 | 75 | 74 |
| Lansing AP..... | 42 5 | 852 | - 4 | 2 | 6 | M | 89 | 87 | 84 | 24 | 76 | 75 | 73 |
| Marquette CO..... | 46 3 | 677 | -14 | - 8 | - 4 | L | 88 | 86 | 83 | 18 | 73 | 71 | 69 |
| Mt. Pleasant..... | 43 4 | 796 | - 9 | - 3 | 1 | M | 89 | 87 | 84 | 24 | 75 | 74 | 73 |
| Muskegon AP..... | 43 1 | 627 | - 2 | 4 | 8 | M | 87 | 85 | 82 | 21 | 75 | 74 | 73 |
| Pontiac..... | 42 4 | 974 | - 6 | 0 | 4 | M | 90 | 88 | 85 | 21 | 76 | 75 | 73 |
| Port Huron..... | 43 0 | 586 | - 6 | - 1 | 3 | M | 90 | 88 | 85 | 21 | 76 | 74 | 73 |
| Saginaw AP..... | 43 3 | 662 | - 7 | - 1 | 3 | M | 88 | 86 | 83 | 23 | 76 | 75 | 73 |
| Sault Ste. Marie AP..... | 46 3 | 721 | -18 | -12 | - 8 | L | 83 | 81 | 78 | 23 | 73 | 71 | 69 |
| Traverse City AP..... | 44 4 | 618 | - 6 | 0 | 4 | M | 89 | 86 | 83 | 22 | 75 | 73 | 72 |
| Ypsilanti..... | 42 1 | 777 | - 3 | - 1 | 5 | M | 92 | 89 | 86 | 22 | 76 | 74 | 73 |
| MINNESOTA | | | | | | | | | | | | | |
| Albert Lea..... | 43 4 | 1235 | -20 | -14 | -10 | M | 91 | 89 | 86 | 24 | 77 | 76 | 74 |
| Alexandria AP..... | 45 5 | 1421 | -26 | -19 | -15 | L | 90 | 88 | 85 | 24 | 76 | 74 | 72 |
| Bemidji AP..... | 47 3 | 1392 | -38 | -32 | -28 | L | 87 | 84 | 81 | 24 | 73 | 72 | 71 |
| Brainerd..... | 46 2 | 1214 | -31 | -24 | -20 | L | 88 | 85 | 82 | 24 | 74 | 73 | 72 |
| Duluth AP..... | 46 5 | 1426 | -25 | -19 | -15 | M | 85 | 82 | 79 | 22 | 73 | 71 | 69 |
| Faribault..... | 44 2 | 1190 | -23 | -16 | -12 | L | 90 | 88 | 85 | 24 | 77 | 75 | 74 |
| Fergus Falls..... | 46 1 | 1210 | -28 | -21 | -17 | L | 92 | 89 | 86 | 24 | 75 | 74 | 72 |
| International Falls AP..... | 48 3 | 1179 | -35 | -29 | -24 | L | 86 | 82 | 79 | 26 | 72 | 69 | 68 |

Climatic Conditions for United States and Canada (Continued)*.a

| Col. 1 State and Station ^b | Col. 2 Latitude ^c | Col. 3 Elev., ^d Ft | Winter | | | | Summer | | | | | | |
|--|---------------------------------|-------------------------------------|---|-----|------|---|---------------------------|-----|----|---|---------------------------|-----|----|
| | | | Col. 4 | | | Col. 5 Coinci- dent Wind Ex- locity ^e | Col. 6 Design Dry-Bulb | | | Col. 7 Out- door Daily Range ^f | Col. 8 Design Wet-Bulb | | |
| | | | Median of Annual Ex- tremes | 99% | 97½% | | 1% | 2½% | 5% | | 1% | 2½% | 5% |
| | | | | | | | | | | | | | |
| MINNESOTA (continued) | | | | | | | | | | | | | |
| Mankato | 44 1 | 785 | -23 | -16 | -12 | L | 91 | 89 | 86 | 24 | 77 | 75 | 74 |
| Minneapolis/St. Paul AP | 44 5 | 822 | -19 | -14 | -10 | L | 92 | 89 | 86 | 22 | 77 | 75 | 74 |
| Rochester AP | 44 0 | 1297 | -23 | -17 | -13 | M | 90 | 88 | 85 | 24 | 77 | 75 | 74 |
| St. Cloud AP | 45 4 | 1034 | -26 | -20 | -16 | L | 90 | 88 | 85 | 24 | 77 | 75 | 73 |
| Virginia | 47 3 | 1435 | -32 | -25 | -21 | L | 86 | 83 | 80 | 23 | 73 | 71 | 69 |
| Willmar | 45 1 | 1133 | -25 | -18 | -14 | L | 91 | 88 | 85 | 24 | 77 | 75 | 73 |
| Winona | 44 1 | 652 | -19 | -12 | - 8 | M | 91 | 89 | 86 | 24 | 77 | 76 | 74 |
| MISSISSIPPI | | | | | | | | | | | | | |
| Biloxi, Keesler AFB | 30 2 | 25 | 26 | 30 | 32 | M | 93 | 92 | 90 | 16 | 82 | 81 | 80 |
| Clarksdale | 34 1 | 178 | 14 | 20 | 24 | L | 98 | 96 | 95 | 21 | 81 | 80 | 79 |
| Columbus AFB | 33 4 | 224 | 13 | 18 | 22 | L | 97 | 95 | 93 | 22 | 79 | 79 | 78 |
| Greenville AFB | 33 3 | 139 | 16 | 21 | 24 | L | 98 | 96 | 94 | 21 | 81 | 80 | 79 |
| Greenwood | 33 3 | 128 | 14 | 19 | 23 | L | 98 | 96 | 94 | 21 | 81 | 80 | 79 |
| Hattiesburg | 31 2 | 200 | 18 | 22 | 26 | L | 97 | 95 | 94 | 21 | 80 | 79 | 78 |
| Jackson AP | 32 2 | 330 | 17 | 21 | 24 | L | 98 | 96 | 94 | 21 | 79 | 78 | 78 |
| Laurel | 31 4 | 264 | 18 | 22 | 26 | L | 97 | 95 | 94 | 21 | 80 | 79 | 78 |
| McComb AP | 31 2 | 458 | 18 | 22 | 26 | L | 96 | 94 | 93 | 18 | 80 | 79 | 79 |
| Meridian AP | 32 2 | 294 | 15 | 20 | 24 | L | 97 | 95 | 94 | 22 | 80 | 79 | 78 |
| Natchez | 31 4 | 168 | 18 | 22 | 26 | L | 96 | 94 | 93 | 21 | 80 | 80 | 79 |
| Tupelo | 34 2 | 289 | 13 | 18 | 22 | L | 98 | 96 | 95 | 22 | 80 | 79 | 78 |
| Vicksburg CO | 32 2 | 234 | 18 | 23 | 26 | L | 97 | 95 | 94 | 21 | 80 | 80 | 79 |
| MISSOURI | | | | | | | | | | | | | |
| Cape Girardeau | 37 1 | 330 | 2 | 8 | 12 | M | 98 | 96 | 94 | 21 | 80 | 79 | 78 |
| Columbia AP | 39 0 | 778 | - 4 | 2 | 6 | M | 97 | 95 | 92 | 22 | 79 | 78 | 77 |
| Farmington AP | 37 5 | 928 | - 2 | 4 | 8 | M | 97 | 95 | 93 | 22 | 79 | 78 | 77 |
| Hannibal | 39 4 | 489 | - 7 | - 1 | 4 | M | 96 | 94 | 91 | 22 | 79 | 78 | 77 |
| Jefferson City | 38 4 | 640 | - 4 | 2 | 6 | M | 97 | 95 | 93 | 23 | 79 | 78 | 77 |
| Joplin AP | 37 1 | 982 | 1 | 7 | 11 | M | 97 | 95 | 93 | 24 | 79 | 78 | 77 |
| Kansas City AP | 39 1 | 742 | - 2 | 4 | 8 | M | 100 | 97 | 94 | 20 | 79 | 77 | 76 |
| Kirksville AP | 40 1 | 966 | -13 | - 7 | - 3 | M | 96 | 94 | 91 | 24 | 79 | 78 | 77 |
| Mexico | 39 1 | 775 | - 7 | - 1 | 3 | M | 96 | 94 | 91 | 22 | 79 | 78 | 77 |
| Moberly | 39 3 | 850 | - 8 | - 2 | 2 | M | 96 | 94 | 91 | 23 | 79 | 78 | 77 |
| Poplar Bluff | 36 5 | 322 | 3 | 9 | 13 | M | 98 | 96 | 94 | 22 | 80 | 79 | 78 |
| Rolla | 38 0 | 1202 | - 3 | 3 | 7 | M | 97 | 95 | 93 | 22 | 79 | 78 | 77 |
| St. Joseph AP | 39 5 | 809 | - 8 | - 1 | 3 | M | 97 | 95 | 92 | 23 | 79 | 78 | 77 |
| St. Louis AP | 38 5 | 535 | - 2 | 4 | 8 | M | 98 | 95 | 92 | 21 | 79 | 78 | 77 |
| St. Louis CO | 38 4 | 465 | 1 | 7 | 11 | M | 96 | 94 | 92 | 18 | 79 | 78 | 77 |
| Sedalia, Whiteman AFB | 38 4 | 838 | - 2 | 4 | 9 | M | 97 | 94 | 92 | 22 | 79 | 77 | 76 |
| Sikeston | 36 5 | 318 | 4 | 10 | 14 | L | 98 | 96 | 94 | 21 | 80 | 79 | 78 |
| Springfield AP | 37 1 | 1265 | 0 | 5 | 10 | M | 97 | 94 | 91 | 23 | 78 | 77 | 76 |
| MONTANA | | | | | | | | | | | | | |
| Billings AP | 45 5 | 3567 | -19 | -10 | - 6 | L | 94 | 91 | 88 | 31 | 68 | 66 | 65 |
| Bozeman | 45 5 | 4856 | -25 | -15 | -11 | L | 88 | 85 | 82 | 32 | 61 | 60 | 59 |
| Butte AP | 46 0 | 5526r | -34 | -24 | -16 | VL | 86 | 83 | 80 | 35 | 60 | 59 | 57 |
| Cut Bank AP | 48 4 | 3838r | -32 | -23 | -17 | L | 89 | 86 | 82 | 35 | 65 | 63 | 61 |
| Glasgow AP | 48 1 | 2277 | -33 | -25 | -20 | L | 96 | 93 | 89 | 29 | 69 | 67 | 65 |
| Glendive | 47 1 | 2076 | -28 | -20 | -16 | L | 96 | 93 | 90 | 29 | 71 | 69 | 68 |
| Great Falls AP | 47 3 | 3664r | -29 | -20 | -16 | L | 91 | 88 | 85 | 28 | 64 | 63 | 61 |
| Havre | 48 3 | 2488 | -32 | -22 | -15 | M | 91 | 87 | 84 | 33 | 66 | 64 | 63 |
| Helena AP | 46 4 | 3893 | -27 | -17 | -13 | L | 90 | 87 | 84 | 32 | 65 | 63 | 61 |
| Kalispell AP | 48 2 | 2965 | -17 | - 7 | - 3 | VL | 88 | 84 | 81 | 34 | 65 | 63 | 62 |
| Lewiston AP | 47 0 | 4132 | -27 | -18 | -14 | L | 89 | 86 | 83 | 30 | 65 | 63 | 62 |
| Livingston AP | 45 4 | 4653 | -26 | -17 | -13 | L | 91 | 88 | 85 | 32 | 63 | 62 | 61 |
| Miles City AP | 46 3 | 2629 | -27 | -19 | -15 | L | 97 | 94 | 91 | 30 | 71 | 69 | 68 |
| Missoula AP | 46 5 | 3200 | -16 | - 7 | - 3 | VL | 92 | 89 | 86 | 36 | 65 | 63 | 61 |
| NEBRASKA | | | | | | | | | | | | | |
| Beatrice | 40 2 | 1235 | -10 | - 3 | 1 | M | 99 | 97 | 94 | 24 | 78 | 77 | 76 |
| Chadron AP | 42 5 | 3300 | -21 | -13 | - 9 | M | 97 | 95 | 92 | 30 | 72 | 70 | 69 |
| Columbus | 41 3 | 1442 | -14 | - 7 | - 3 | M | 98 | 96 | 93 | 25 | 78 | 76 | 75 |
| Freemont | 41 3 | 1203 | -14 | - 7 | - 3 | M | 99 | 97 | 94 | 22 | 78 | 77 | 76 |
| Grand Island AP | 41 0 | 1841 | -14 | - 6 | - 2 | M | 98 | 95 | 92 | 28 | 76 | 75 | 74 |
| Hastings | 40 4 | 1932 | -11 | - 3 | 1 | M | 98 | 96 | 94 | 27 | 77 | 75 | 74 |
| Kearney | 40 4 | 2146 | -14 | - 6 | - 2 | M | 97 | 95 | 92 | 28 | 76 | 75 | 74 |
| Lincoln CO | 40 5 | 1150 | -10 | - 4 | 0 | M | 100 | 96 | 93 | 24 | 78 | 77 | 76 |

Climatic Conditions for United States and Canada (Continued)*.a

| Col. 1 State and Station ^b | Col. 2 Latitude ^c | Col. 3 Elev., ^d Ft | Winter | | | | Summer | | | | | | |
|--|---------------------------------|-------------------------------------|---|-----|------|--|---------------------------|-----|-----|---|---------------------------|-----|-----|
| | | | Col. 4 | | | Col. 5 Coincident Wind Ex- Locity ^e | Col. 6 Design Dry-Bulb | | | Col. 7 Out- door Daily Range ^f | Col. 8 Design Wet-Bulb | | |
| | | | Medion of Annual Ex- tremes | 99% | 97½% | | 1% | 2½% | 5% | | 1% | 2½% | 5% |
| NEBRASKA (continued) | | | | | | | | | | | | | |
| McCook..... | 40 1 | 2565 | -12 | - 4 | 0 | M | 99 | 97 | 94 | 28 | 74 | 72 | 71 |
| Norfolk..... | 42 0 | 1532 | -18 | -11 | - 7 | M | 97 | 95 | 92 | 30 | 78 | 76 | 75 |
| North Platte AP..... | 41 1 | 2779 | -13 | - 6 | - 2 | M | 97 | 94 | 90 | 28 | 74 | 73 | 72 |
| Omaha AP..... | 41 2 | 978 | -12 | - 5 | - 1 | M | 97 | 94 | 91 | 22 | 79 | 78 | 76 |
| Scottsbluff AP..... | 41 5 | 3950 | -16 | - 8 | - 4 | M | 96 | 94 | 91 | 31 | 70 | 69 | 67 |
| Sidney AP..... | 41 1 | 4292 | -15 | - 7 | - 2 | M | 95 | 92 | 89 | 31 | 70 | 69 | 67 |
| NEVADA† | | | | | | | | | | | | | |
| Carson City..... | 39 1 | 4675 | - 4 | 3 | 7 | VL | 93 | 91 | 88 | 42 | 62 | 61 | 60 |
| Elko AP..... | 40 5 | 5075 | -21 | -13 | - 7 | VL | 94 | 92 | 90 | 42 | 64 | 62 | 61 |
| Ely AP..... | 39 1 | 6257 | -15 | - 6 | - 2 | VL | 90 | 88 | 86 | 39 | 60 | 59 | 58 |
| Las Vegas AP..... | 36 1 | 2162 | 18 | 23 | 26 | VL | 108 | 106 | 104 | 30 | 72 | 71 | 70 |
| Lovelock AP..... | 40 0 | 3900 | 0 | 7 | 11 | VL | 98 | 96 | 93 | 42 | 65 | 64 | 62 |
| Reno AP..... | 39 3 | 4404 | - 2 | 2 | 7 | VL | 95 | 92 | 90 | 45 | 64 | 62 | 61 |
| Reno CO..... | 39 3 | 4490 | 8 | 12 | 17 | VL | 94 | 92 | 89 | 45 | 64 | 62 | 61 |
| Tonopah AP..... | 38 0 | 5426 | 2 | 9 | 13 | VL | 95 | 92 | 90 | 40 | 64 | 63 | 62 |
| Winnemucca AP..... | 40 5 | 4299 | - 8 | 1 | 5 | VL | 97 | 95 | 93 | 42 | 64 | 62 | 61 |
| NEW HAMPSHIRE | | | | | | | | | | | | | |
| Berlin..... | 44 3 | 1110 | -25 | -19 | -15 | L | 87 | 85 | 82 | 22 | 73 | 71 | 70. |
| Claremont..... | 43 2 | 420 | -19 | -13 | - 9 | L | 89 | 87 | 84 | 24 | 74 | 73 | 72 |
| Concord AP..... | 43 1 | 339 | -17 | -11 | - 7 | M | 91 | 88 | 85 | 26 | 75 | 73 | 72 |
| Keene..... | 43 0 | 490 | -17 | -12 | - 8 | M | 90 | 88 | 85 | 24 | 75 | 73 | 72 |
| Laconia..... | 43 3 | 505 | -22 | -16 | -12 | M | 89 | 87 | 84 | 25 | 74 | 73 | 72 |
| Manchester, Grenier AFB..... | 43 0 | 253 | -11 | - 5 | 1 | M | 92 | 89 | 86 | 24 | 76 | 74 | 73 |
| Portsmouth, Pease AFB..... | 43 1 | 127 | - 8 | - 2 | 3 | M | 88 | 86 | 83 | 22 | 75 | 73 | 72 |
| NEW JERSEY | | | | | | | | | | | | | |
| Atlantic City CO..... | 39 3 | 11 | 10 | 14 | 18 | H | 91 | 88 | 85 | 18 | 78 | 77 | 76 |
| Long Branch..... | 40 2 | 20 | 4 | 9 | 13 | H | 93 | 91 | 88 | 18 | 77 | 76 | 75 |
| Newark AP..... | 40 4 | 11 | 6 | 11 | 15 | M | 94 | 91 | 88 | 20 | 77 | 76 | 75 |
| New Brunswick..... | 40 3 | 86 | 3 | 8 | 12 | M | 91 | 89 | 86 | 19 | 77 | 76 | 75 |
| Paterson..... | 40 5 | 100 | 3 | 8 | 12 | M | 93 | 91 | 88 | 21 | 77 | 76 | 75 |
| Phillipsburg..... | 40 4 | 180 | 1 | 6 | 10 | L | 93 | 91 | 88 | 21 | 77 | 76 | 75 |
| Trenton CO..... | 40 1 | 144 | 7 | 12 | 16 | M | 92 | 90 | 87 | 19 | 78 | 77 | 76 |
| Vineland..... | 39 3 | 95 | 7 | 12 | 16 | M | 93 | 90 | 87 | 19 | 78 | 77 | 76 |
| NEW MEXICO | | | | | | | | | | | | | |
| Alamagordo, Holloman AFB..... | 32 5 | 4070 | 12 | 18 | 22 | L | 100 | 98 | 96 | 30 | 70 | 69 | 68 |
| Albuquerque AP..... | 35 0 | 5310 | 6 | 14 | 17 | L | 96 | 94 | 92 | 27 | 66 | 65 | 64 |
| Artesia..... | 32 5 | 3375 | 9 | 16 | 19 | L | 101 | 99 | 97 | 30 | 71 | 70 | 69 |
| Carlsbad AP..... | 32 2 | 3234 | 11 | 17 | 21 | L | 101 | 99 | 97 | 28 | 72 | 71 | 70 |
| Clovis AP..... | 34 3 | 4279 | 2 | 14 | 17 | L | 99 | 97 | 95 | 28 | 70 | 69 | 68 |
| Farmington AP..... | 36 5 | 5495 | - 3 | 6 | 9 | VL | 95 | 93 | 91 | 30 | 66 | 65 | 64 |
| Gallup..... | 35 3 | 6465 | -13 | - 5 | - 1 | VL | 92 | 90 | 87 | 32 | 64 | 63 | 62 |
| Grants..... | 35 1 | 6520 | -15 | - 7 | - 3 | VL | 91 | 89 | 86 | 32 | 64 | 63 | 62 |
| Hobbs AP..... | 32 4 | 3664 | . 9 | 15 | 19 | L | 101 | 99 | 96 | 29 | 72 | 71 | 70 |
| Las Cruces..... | 32 2 | 3900 | 13 | 19 | 23 | L | 102 | 100 | 97 | 30 | 70 | 69 | 68 |
| Los Alamos..... | 35 5 | 7410 | - 4 | 5 | 9 | L | 88 | 86 | 83 | 32 | 64 | 63 | 62 |
| Raton AP..... | 36 5 | 6379 | -11 | - 2 | 2 | L | 92 | 90 | 88 | 34 | 66 | 65 | 64 |
| Roswell, Walker AFB..... | 33 2 | 3643 | 5 | 16 | 19 | L | 101 | 99 | 97 | 33 | 71 | 70 | 69 |
| Santa Fe CO..... | 35 4 | 7045 | - 2 | 7 | 11 | L | 90 | 88 | 85 | 28 | 65 | 63 | 62 |
| Silver City AP..... | 32 4 | 5373 | 8 | 14 | 18 | VL | 95 | 93 | 91 | 30 | 68 | 67 | 66 |
| Socorro AP..... | 34 0 | 4617 | 6 | 13 | 17 | L | 99 | 97 | 94 | 30 | 67 | 66 | 65 |
| Tucumcari AP..... | 35 1 | 4053 | 1 | 9 | 13 | L | 99 | 97 | 95 | 28 | 71 | 70 | 69 |
| NEW YORK | | | | | | | | | | | | | |
| Albany AP..... | 42 5 | 277 | -14 | - 5 | 0 | L | 91 | 88 | 85 | 23 | 76 | 74 | 73 |
| Albany CO..... | 42 5 | 19 | - 5 | 1 | 5 | L | 91 | 89 | 86 | 20 | 76 | 74 | 73 |
| Auburn..... | 43 0 | 715 | -10 | - 2 | 2 | M | 89 | 87 | 84 | 22 | 75 | 73 | 72 |
| Batavia..... | 43 0 | 900 | - 7 | - 1 | 3 | M | 89 | 87 | 84 | 22 | 75 | 74 | 72 |
| Binghamton CO..... | 42 1 | 858 | - 8 | - 2 | 2 | L | 91 | 89 | 86 | 20 | 74 | 72 | 71 |
| Buffalo AP..... | 43 0 | 705r | - 3 | 3 | 6 | M | 88 | 86 | 83 | 21 | 75 | 73 | 72 |
| Cortland..... | 42 4 | 1129 | -11 | - 5 | - 1 | L | 90 | 88 | 85 | 23 | 75 | 73 | 72 |
| Dunkirk..... | 42 3 | 590 | - 2 | 4 | 8 | M | 88 | 86 | 83 | 18 | 75 | 74 | 72 |
| Elmira AP..... | 42 1 | 860 | - 5 | 1 | 5 | L | 92 | 90 | 87 | 24 | 75 | 73 | 72 |
| Geneva..... | 42 5 | 590 | - 8 | - 2 | 2 | M | 91 | 89 | 86 | 22 | 75 | 73 | 72 |
| Glens Falls..... | 43 2 | 321 | -17 | -11 | - 7 | L | 88 | 86 | 83 | 23 | 74 | 72 | 71 |
| Gloversville..... | 43 1 | 770 | -12 | - 6 | - 2 | L | 89 | 87 | 84 | 23 | 75 | 73 | 71 |
| Hornell..... | 42 2 | 1325 | -15 | - 9 | - 5 | L | 87 | 85 | 82 | 24 | 74 | 72 | 71 |

Climatic Conditions for United States and Canada (Continued)*.a

| Col. 1 State and Station ^b | Col. 2 Latitude ^c | Col. 3 Elev. ^d Ft | Winter | | | | Summer | | | | | | |
|--|---------------------------------|------------------------------------|---|-----|------|---|---------------------------|-----|----|---|---------------------------|-----|----|
| | | | Col. 4 | | | Col. 5 Coinci- dent Wind Ve- locity ^e | Col. 6 Design Dry-Bulb | | | Col. 7 Out- door Daily Range ^f | Col. 8 Design Wet-Bulb | | |
| | | | Median of Annual Ex- tremes | 99% | 97½% | | 1% | 2½% | 5% | | 1% | 2½% | 5% |
| | | | | | | | | | | | | | |
| NEW YORK (continued) | | | | | | | | | | | | | |
| Ithaca..... | 42 3 | 950 | -10 | - 4 | 0 | L | 91 | 88 | 85 | 24 | 75 | 73 | 72 |
| Jamestown..... | 42 1 | 1390 | - 5 | 1 | 5 | M | 88 | 86 | 83 | 20 | 75 | 73 | 72 |
| Kingston..... | 42 0 | 279 | - 8 | - 2 | 2 | L | 92 | 90 | 87 | 22 | 76 | 74 | 73 |
| Lockport..... | 43 1 | 520 | - 4 | 2 | 6 | M | 87 | 85 | 82 | 21 | 75 | 74 | 72 |
| Massena AP..... | 45 0 | 202r | -22 | -16 | -12 | M | 86 | 84 | 81 | 20 | 75 | 74 | 72 |
| Newburgh-Stewart AFB..... | 41 3 | 460 | - 4 | 2 | 6 | M | 92 | 89 | 86 | 21 | 78 | 76 | 74 |
| NYC-Central Park..... | 40 5 | 132 | 6 | 11 | 15 | H | 94 | 91 | 88 | 17 | 77 | 76 | 75 |
| NYC-Kennedy AP..... | 40 4 | 16 | 12 | 17 | 21 | H | 91 | 87 | 84 | 16 | 77 | 76 | 75 |
| NYC-LaGuardia AP..... | 40 5 | 19 | 7 | 12 | 16 | H | 93 | 90 | 87 | 16 | 77 | 76 | 75 |
| Niagara Falls AP..... | 43 1 | 596 | - 2 | 4 | 7 | M | 88 | 86 | 83 | 20 | 75 | 74 | 73 |
| Olean..... | 42 1 | 1420 | -13 | - 8 | - 3 | L | 87 | 85 | 82 | 23 | 74 | 72 | 71 |
| Oneonta..... | 42 3 | 1150 | -13 | - 7 | - 3 | L | 89 | 87 | 84 | 24 | 74 | 72 | 71 |
| Oswego CO..... | 43 3 | 300 | - 4 | 2 | 6 | M | 86 | 84 | 81 | 20 | 75 | 74 | 72 |
| Plattsburg AFB..... | 44 4 | 165 | -16 | -10 | - 6 | L | 86 | 84 | 81 | 22 | 74 | 73 | 71 |
| Poughkeepsie..... | 41 4 | 103 | - 6 | - 1 | 3 | L | 93 | 90 | 87 | 21 | 77 | 75 | 74 |
| Rochester AP..... | 43 1 | 543 | - 5 | 2 | 5 | M | 91 | 88 | 85 | 22 | 75 | 74 | 72 |
| Rome-Griffiss AFB..... | 43 1 | 515 | -13 | - 7 | - 3 | L | 90 | 87 | 84 | 22 | 76 | 74 | 73 |
| Schenectady..... | 42 5 | 217 | -11 | - 5 | - 1 | L | 90 | 88 | 85 | 22 | 75 | 73 | 72 |
| Suffolk County AFB..... | 40 5 | 57 | 4 | 9 | 13 | H | 87 | 84 | 81 | 16 | 76 | 75 | 74 |
| Syracuse AP..... | 43 1 | 424 | -10 | - 2 | 2 | M | 90 | 87 | 85 | 20 | 76 | 74 | 73 |
| Utica..... | 43 1 | 714 | -12 | - 6 | - 2 | L | 89 | 87 | 84 | 22 | 75 | 73 | 72 |
| Watertown..... | 44 0 | 497 | -20 | -14 | -10 | M | 86 | 84 | 81 | 20 | 75 | 74 | 72 |
| NORTH CAROLINA | | | | | | | | | | | | | |
| Asheville AP..... | 35 3 | 2170r | 8 | 13 | 17 | L | 91 | 88 | 86 | 21 | 75 | 74 | 73 |
| Charlotte AP..... | 35 1 | 735 | 13 | 18 | 22 | L | 96 | 94 | 92 | 20 | 78 | 77 | 76 |
| Durham..... | 36 0 | 406 | 11 | 15 | 19 | L | 94 | 92 | 89 | 20 | 78 | 77 | 76 |
| Elizabeth City AP..... | 36 2 | 10 | 14 | 18 | 22 | M | 93 | 91 | 89 | 18 | 80 | 79 | 78 |
| Fayetteville, Pope AFB..... | 35 1 | 95 | 13 | 17 | 20 | L | 97 | 94 | 92 | 20 | 80 | 79 | 78 |
| Goldsboro, Seymour-Johnson AFB..... | 35 2 | 88 | 14 | 18 | 21 | M | 95 | 92 | 90 | 18 | 80 | 79 | 78 |
| Greensboro AP..... | 36 1 | 897 | 9 | 14 | 17 | L | 94 | 91 | 89 | 21 | 77 | 76 | 75 |
| Greenville..... | 35 4 | 25 | 14 | 18 | 22 | M | 95 | 93 | 90 | 19 | 81 | 80 | 79 |
| Henderson..... | 36 2 | 510 | 8 | 12 | 16 | L | 94 | 92 | 89 | 20 | 79 | 78 | 77 |
| Hickory..... | 35 4 | 1165 | 9 | 14 | 18 | L | 93 | 91 | 88 | 21 | 77 | 76 | 75 |
| Jacksonville..... | 34 5 | 24 | 17 | 21 | 25 | M | 94 | 92 | 89 | 18 | 81 | 80 | 79 |
| Lumberton..... | 34 4 | 132 | 14 | 18 | 22 | L | 95 | 93 | 90 | 20 | 81 | 80 | 79 |
| New Bern AP..... | 35 1 | 17 | 14 | 18 | 22 | L | 94 | 92 | 89 | 18 | 81 | 80 | 79 |
| Raleigh/Durham AP..... | 35 5 | 433 | 13 | 16 | 20 | L | 95 | 92 | 90 | 20 | 79 | 78 | 77 |
| Rocky Mount..... | 36 0 | 81 | 12 | 16 | 20 | L | 95 | 93 | 90 | 19 | 80 | 79 | 78 |
| Wilmington AP..... | 34 2 | 30 | 19 | 23 | 27 | L | 93 | 91 | 89 | 18 | 82 | 81 | 80 |
| Winston-Salem AP..... | 36 1 | 967 | 9 | 14 | 17 | L | 94 | 91 | 89 | 20 | 77 | 76 | 75 |
| NORTH DAKOTA | | | | | | | | | | | | | |
| Bismarck AP..... | 46 5 | 1647 | -31 | -24 | -19 | VL | 95 | 91 | 88 | 27 | 74 | 72 | 70 |
| Devil's Lake..... | 48 1 | 1471 | -30 | -23 | -19 | M | 93 | 89 | 86 | 25 | 73 | 71 | 69 |
| Dickinson AP..... | 46 5 | 2595 | -31 | -23 | -19 | L | 96 | 93 | 90 | 25 | 72 | 70 | 68 |
| Fargo AP..... | 46 5 | 900 | -28 | -22 | -17 | L | 92 | 88 | 85 | 25 | 76 | 74 | 72 |
| Grand Forks AP..... | 48 0 | 832 | -30 | -26 | -23 | L | 91 | 87 | 84 | 25 | 74 | 72 | 70 |
| Jamestown AP..... | 47 0 | 1492 | -29 | -22 | -18 | L | 95 | 91 | 88 | 26 | 75 | 73 | 71 |
| Minot AP..... | 48 2 | 1713 | -31 | -24 | -20 | M | 91 | 88 | 84 | 25 | 72 | 70 | 68 |
| Williston..... | 48 1 | 1877 | -28 | -21 | -17 | M | 94 | 90 | 87 | 25 | 71 | 69 | 67 |
| OHIO | | | | | | | | | | | | | |
| Akron/Canton AP..... | 41 0 | 1210 | - 5 | 1 | 6 | M | 89 | 87 | 84 | 21 | 75 | 73 | 72 |
| Ashtabula..... | 42 0 | 690 | - 3 | 3 | 7 | M | 89 | 87 | 84 | 18 | 76 | 75 | 74 |
| Athens..... | 39 2 | 700 | - 3 | 3 | 7 | M | 93 | 91 | 88 | 22 | 77 | 76 | 75 |
| Bowling Green..... | 41 3 | 675 | - 7 | - 1 | 3 | M | 93 | 91 | 88 | 23 | 77 | 75 | 74 |
| Cambridge..... | 40 0 | 800 | - 6 | 0 | 4 | M | 91 | 89 | 86 | 23 | 77 | 76 | 75 |
| Chillicothe..... | 39 2 | 638 | - 1 | 5 | 9 | M | 93 | 91 | 88 | 22 | 77 | 76 | 75 |
| Cincinnati CO..... | 39 1 | 761 | 2 | 8 | 12 | L | 94 | 92 | 90 | 21 | 78 | 77 | 76 |
| Cleveland AP..... | 41 2 | 777r | - 2 | 2 | 7 | M | 91 | 89 | 86 | 22 | 76 | 75 | 74 |
| Columbus AP..... | 40 0 | 812 | - 1 | 2 | 7 | M | 92 | 88 | 86 | 24 | 77 | 76 | 75 |
| Dayton AP..... | 39 5 | 997 | - 2 | 0 | 6 | M | 92 | 90 | 87 | 20 | 77 | 75 | 74 |
| Defiance..... | 41 2 | 700 | - 7 | - 1 | 1 | M | 93 | 91 | 88 | 24 | 77 | 76 | 74 |
| Findlay AP..... | 41 0 | 797 | - 6 | 0 | 4 | M | 92 | 90 | 88 | 24 | 77 | 76 | 75 |

Climatic Conditions for United States and Canada (Continued)*.a

| Col. 1 State and Station ^b | Col. 2 Latitude ^c | Col. 3 Elev. ^d Ft | Winter | | | | Summer | | | | | | |
|--|---------------------------------|------------------------------------|---|-----|------|---|---------------------------|-----|----|---|---------------------------|-----|----|
| | | | Col. 4 | | | Col. 5 Coinci- dent Wind Ve- locity ^e | Col. 6 Design Dry-Bulb | | | Col. 7 Out- door Daily Range ^f | Col. 8 Design Wet-Bulb | | |
| | | | Median of Annual Ex- tremes | 99% | 97½% | | 1% | 2½% | 5% | | 1% | 2½% | 5% |
| | | | | | | | | | | | | | |
| OHIO (continued) | | | | | | | | | | | | | |
| Fremont..... | 41 2 | 600 | - 7 | - 1 | 3 | M | 92 | 90 | 87 | 24 | 76 | 75 | 74 |
| Hamilton..... | 39 2 | 650 | - 2 | 4 | 8 | M | 94 | 92 | 90 | 22 | 78 | 77 | 76 |
| Lancaster..... | 39 4 | 920 | - 5 | 1 | 5 | M | 93 | 91 | 88 | 23 | 77 | 76 | 75 |
| Lima..... | 40 4 | 860 | - 6 | 0 | 4 | M | 93 | 91 | 88 | 24 | 77 | 76 | 75 |
| Mansfield AP..... | 40 5 | 1297 | - 7 | 1 | 3 | M | 91 | 89 | 86 | 22 | 76 | 75 | 74 |
| Marion..... | 40 4 | 920 | - 5 | 1 | 6 | M | 93 | 91 | 88 | 23 | 77 | 76 | 75 |
| Middletown..... | 39 3 | 635 | - 3 | 3 | 7 | M | 93 | 91 | 88 | 22 | 77 | 76 | 75 |
| Newark..... | 40 1 | 825 | - 7 | - 1 | 3 | M | 92 | 90 | 87 | 23 | 77 | 76 | 75 |
| Norwalk..... | 41 1 | 720 | - 7 | - 1 | 3 | M | 92 | 90 | 87 | 22 | 76 | 75 | 74 |
| Portsmouth..... | 38 5 | 530 | 0 | 5 | 9 | L | 94 | 92 | 89 | 22 | 77 | 76 | 75 |
| Sandusky CO..... | 41 3 | 606 | - 2 | 4 | 8 | M | 92 | 90 | 87 | 21 | 76 | 75 | 74 |
| Springfield..... | 40 0 | 1020 | - 3 | 3 | 7 | M | 93 | 90 | 88 | 21 | 77 | 76 | 75 |
| Stuebenville..... | 40 2 | 992 | - 2 | 4 | 9 | M | 91 | 89 | 86 | 22 | 76 | 75 | 74 |
| Toledo AP..... | 41 4 | 676r | - 5 | 1 | 5 | M | 92 | 90 | 87 | 25 | 77 | 75 | 74 |
| Warren..... | 41 2 | 900 | - 6 | 0 | 4 | M | 90 | 88 | 85 | 23 | 75 | 74 | 73 |
| Wooster..... | 40 5 | 1030 | - 7 | - 1 | 3 | M | 90 | 88 | 85 | 22 | 76 | 75 | 74 |
| Youngstown AP..... | 41 2 | 1178 | - 5 | 1 | 6 | M | 89 | 86 | 84 | 23 | 75 | 74 | 73 |
| Zanesville AP..... | 40 0 | 881 | - 7 | - 1 | 3 | M | 92 | 89 | 87 | 23 | 77 | 76 | 75 |
| OKLAHOMA | | | | | | | | | | | | | |
| Ada..... | 34 5 | 1015 | 6 | 12 | 16 | H | 102 | 100 | 98 | 23 | 79 | 78 | 77 |
| Altus AFB..... | 34 4 | 1390 | 7 | 14 | 18 | H | 103 | 101 | 99 | 25 | 77 | 76 | 75 |
| Ardmore..... | 34 2 | 880 | 9 | 15 | 19 | H | 103 | 101 | 99 | 23 | 79 | 78 | 77 |
| Bartlesville..... | 36 5 | 715 | - 1 | 5 | 9 | H | 101 | 99 | 97 | 23 | 79 | 78 | 77 |
| Chickasha..... | 35 0 | 1085 | 5 | 12 | 16 | H | 103 | 101 | 99 | 24 | 77 | 76 | 75 |
| Enid-Vance AFB..... | 36 2 | 1287 | 3 | 10 | 14 | H | 103 | 100 | 98 | 24 | 78 | 77 | 76 |
| Lawton AP..... | 34 3 | 1108 | 6 | 13 | 16 | H | 103 | 101 | 98 | 24 | 78 | 77 | 76 |
| McAlester..... | 34 5 | 760 | 7 | 13 | 17 | H | 102 | 100 | 98 | 23 | 79 | 78 | 77 |
| Muskogee AP..... | 35 4 | 610 | 6 | 12 | 16 | M | 102 | 99 | 96 | 23 | 79 | 78 | 77 |
| Norman..... | 35 1 | 1109 | 5 | 11 | 15 | H | 101 | 99 | 97 | 24 | 78 | 77 | 76 |
| Oklahoma City AP..... | 35 2 | 1280 | 4 | 11 | 15 | H | 100 | 97 | 95 | 23 | 78 | 77 | 76 |
| Ponca City..... | 36 4 | 996 | 1 | 8 | 12 | H | 102 | 100 | 97 | 24 | 78 | 77 | 76 |
| Seminole..... | 35 2 | 865 | 6 | 12 | 16 | H | 102 | 100 | 98 | 23 | 78 | 77 | 76 |
| Stillwater..... | 36 1 | 884 | 2 | 9 | 13 | H | 101 | 99 | 97 | 24 | 78 | 77 | 76 |
| Tulsa AP..... | 36 1 | 650 | 4 | 12 | 16 | H | 102 | 99 | 96 | 22 | 79 | 78 | 77 |
| Woodward..... | 36 3 | 1900 | - 3 | 4 | 8 | H | 103 | 101 | 98 | 26 | 76 | 74 | 73 |
| OREGON | | | | | | | | | | | | | |
| Albany..... | 44 4 | 224 | 17 | 23 | 27 | VL | 91 | 88 | 84 | 31 | 69 | 67 | 65 |
| Astoria AP..... | 46 1 | 8 | 22 | 27 | 30 | M | 79 | 76 | 72 | 16 | 61 | 60 | 59 |
| Baker AP..... | 44 5 | 3368 | -10 | - 3 | 1 | VL | 94 | 92 | 89 | 30 | 66 | 65 | 63 |
| Bend..... | 44 0 | 3599 | - 7 | 0 | 4 | VL | 89 | 87 | 84 | 33 | 64 | 62 | 61 |
| Corvallis..... | 44 3 | 221 | 17 | 23 | 27 | VL | 91 | 88 | 84 | 31 | 69 | 67 | 65 |
| Eugene AP..... | 44 1 | 364 | 16 | 22 | 26 | VL | 91 | 88 | 84 | 31 | 69 | 67 | 65 |
| Grants Pass..... | 42 3 | 925 | 16 | 22 | 26 | VL | 94 | 92 | 89 | 33 | 68 | 66 | 65 |
| Klamath Falls AP..... | 42 1 | 4091 | - 5 | 1 | 5 | VL | 89 | 87 | 84 | 36 | 63 | 62 | 61 |
| Medford AP..... | 42 2 | 1298 | 15 | 21 | 23 | VL | 98 | 94 | 91 | 35 | 70 | 68 | 66 |
| Pendleton AP..... | 45 4 | 1492 | - 2 | 3 | 10 | VL | 97 | 94 | 91 | 29 | 66 | 65 | 63 |
| Portland AP..... | 45 4 | 21 | 17 | 21 | 24 | L | 89 | 85 | 81 | 23 | 69 | 67 | 66 |
| Portland CO..... | 45 3 | 57 | 21 | 26 | 29 | L | 91 | 88 | 84 | 21 | 69 | 68 | 67 |
| Roseburg AP..... | 43 1 | 505 | 19 | 25 | 29 | VL | 93 | 91 | 88 | 30 | 69 | 67 | 65 |
| Salem AP..... | 45 0 | 195 | 15 | 21 | 25 | VL | 92 | 88 | 84 | 31 | 69 | 67 | 66 |
| The Dalles..... | 45 4 | 102 | 7 | 13 | 17 | VL | 93 | 91 | 88 | 28 | 70 | 68 | 67 |
| PENNSYLVANIA | | | | | | | | | | | | | |
| Allentown AP..... | 40 4 | 376 | - 2 | 3 | 5 | M | 92 | 90 | 87 | 22 | 77 | 75 | 74 |
| Altoona CO..... | 40 2 | 1468 | - 4 | 1 | 5 | L | 89 | 87 | 84 | 23 | 74 | 73 | 72 |
| Butler..... | 40 4 | 1100 | - 8 | - 2 | 2 | L | 91 | 89 | 86 | 22 | 75 | 74 | 73 |
| Chambersburg..... | 40 0 | 640 | 0 | 5 | 9 | L | 94 | 92 | 89 | 23 | 76 | 75 | 74 |
| Erie AP..... | 42 1 | 732 | 1 | 7 | 11 | M | 88 | 85 | 82 | 18 | 76 | 74 | 73 |
| Harrisburg AP..... | 40 1 | 335 | 4 | 9 | 13 | L | 92 | 89 | 86 | 21 | 76 | 75 | 74 |
| Johnstown..... | 40 2 | 1214 | - 4 | 1 | 5 | L | 91 | 87 | 85 | 23 | 74 | 73 | 72 |
| Lancaster..... | 40 1 | 255 | - 3 | 2 | 6 | L | 92 | 90 | 87 | 22 | 77 | 76 | 75 |
| Meadville..... | 41 4 | 1065 | - 6 | 0 | 4 | M | 88 | 86 | 83 | 21 | 75 | 73 | 72 |
| New Castle..... | 41 0 | 825 | - 7 | - 1 | 4 | M | 91 | 89 | 86 | 23 | 75 | 74 | 73 |

Climatic Conditions for United States and Canada (Continued)*.a

| Col. 1 State and Station ^b | Col. 2 Latitude ^c | Col. 3 Elev. ^d Ft | Winter | | | | Summer | | | | | | |
|--|---------------------------------|------------------------------------|---|-----|------|---|---------------------------|-----|----|---|---------------------------|-----|----|
| | | | Col. 4 | | | Col. 5 Coinci- dent Wind Ve- locity ^e | Col. 6 Design Dry-Bulb | | | Col. 7 Out- door Daily Range ^f | Col. 8 Design Wet-Bulb | | |
| | | | Median of Annual Ex- tremes | 99% | 97½% | | 1% | 2½% | 5% | | 1% | 2½% | 5% |
| | | | | | | | | | | | | | |
| PENNSYLVANIA (continued) | | | | | | | | | | | | | |
| Philadelphia AP..... | 39 5 | 7 | 7 | 11 | 15 | M | 93 | 90 | 87 | 21 | 78 | 77 | 76 |
| Pittsburgh AP..... | 40 3 | 1137 | - 1 | 5 | 9 | M | 90 | 87 | 85 | 22 | 75 | 74 | 73 |
| Pittsburgh CO..... | 40 3 | 749 _r | 1 | 7 | 11 | M | 90 | 88 | 85 | 19 | 75 | 74 | 73 |
| Reading CO..... | 40 2 | 226 | 1 | 6 | 9 | M | 92 | 90 | 87 | 19 | 77 | 76 | 75 |
| Scranton/Wilkes-Barre..... | 41 2 | 940 | - 3 | 2 | 6 | L | 89 | 87 | 84 | 19 | 75 | 74 | 73 |
| State College..... | 40 5 | 1175 | - 3 | 2 | 6 | L | 89 | 87 | 84 | 23 | 74 | 73 | 72 |
| Sunbury..... | 40 5 | 480 | - 2 | 3 | 7 | L | 91 | 89 | 86 | 22 | 76 | 75 | 74 |
| Uniontown..... | 39 5 | 1040 | - 1 | 4 | 8 | L | 90 | 88 | 85 | 22 | 75 | 74 | 73 |
| Warren..... | 41 5 | 1280 | - 8 | - 3 | 1 | L | 89 | 87 | 84 | 24 | 75 | 73 | 72 |
| West Chester..... | 40 0 | 440 | 4 | 9 | 13 | M | 92 | 90 | 87 | 20 | 77 | 76 | 75 |
| Williamsport AP..... | 41 1 | 527 | - 5 | 1 | 5 | L | 91 | 89 | 86 | 23 | 76 | 75 | 74 |
| York..... | 40 0 | 390 | - 1 | 4 | 8 | L | 93 | 91 | 88 | 22 | 77 | 76 | 75 |
| RHODE ISLAND | | | | | | | | | | | | | |
| Newport..... | 41 3 | 20 | 1 | 5 | 11 | H | 86 | 84 | 81 | 16 | 75 | 74 | 73 |
| Providence AP..... | 41 4 | 55 | 0 | 6 | 10 | M | 89 | 86 | 83 | 19 | 76 | 75 | 74 |
| SOUTH CAROLINA | | | | | | | | | | | | | |
| Anderson..... | 34 3 | 764 | 13 | 18 | 22 | L | 96 | 94 | 91 | 21 | 77 | 76 | 75 |
| Charleston AFB..... | 32 5 | 41 | 19 | 23 | 27 | L | 94 | 92 | 90 | 18 | 81 | 80 | 79 |
| Charleston CO..... | 32 5 | 9 | 23 | 26 | 30 | L | 95 | 93 | 90 | 13 | 81 | 80 | 79 |
| Columbia AP..... | 34 0 | 217 | 16 | 20 | 23 | L | 98 | 96 | 94 | 22 | 79 | 79 | 78 |
| Florence AP..... | 34 1 | 146 | 16 | 21 | 25 | L | 96 | 94 | 92 | 21 | 80 | 79 | 78 |
| Georgetown..... | 33 2 | 14 | 19 | 23 | 26 | L | 93 | 91 | 88 | 18 | 81 | 80 | 79 |
| Greenville AP..... | 34 5 | 957 | 14 | 19 | 23 | L | 95 | 93 | 91 | 21 | 77 | 76 | 75 |
| Greenwood..... | 34 1 | 671 | 15 | 19 | 23 | L | 97 | 95 | 92 | 21 | 78 | 77 | 76 |
| Orangeburg..... | 33 3 | 244 | 17 | 21 | 25 | L | 97 | 95 | 92 | 20 | 80 | 79 | 78 |
| Rock Hill..... | 35 0 | 470 | 13 | 17 | 21 | L | 97 | 95 | 92 | 20 | 78 | 77 | 76 |
| Spartanburg AP..... | 35 0 | 816 | 13 | 18 | 22 | L | 95 | 93 | 90 | 20 | 77 | 76 | 75 |
| Sumter-Shaw AFB..... | 34 0 | 291 | 18 | 23 | 26 | L | 96 | 94 | 92 | 21 | 80 | 79 | 78 |
| SOUTH DAKOTA | | | | | | | | | | | | | |
| Aberdeen AP..... | 45 3 | 1296 | -29 | -22 | -18 | L | 95 | 92 | 89 | 27 | 77 | 75 | 74 |
| Brookings..... | 44 2 | 1642 | -26 | -19 | -15 | M | 93 | 90 | 87 | 25 | 77 | 75 | 74 |
| Huron AP..... | 44 3 | 1282 | -24 | -16 | -12 | L | 97 | 93 | 90 | 28 | 77 | 75 | 74 |
| Mitchell..... | 43 5 | 1346 | -22 | -15 | -11 | M | 96 | 94 | 91 | 28 | 77 | 76 | 74 |
| Pierre AP..... | 44 2 | 1718 _r | -21 | -13 | - 9 | M | 98 | 96 | 93 | 29 | 76 | 74 | 73 |
| Rapid City AP..... | 44 0 | 3165 | -17 | - 9 | - 6 | M | 96 | 94 | 91 | 28 | 72 | 71 | 69 |
| Sioux Falls AP..... | 43 4 | 1420 | -21 | -14 | -10 | M | 95 | 92 | 89 | 24 | 77 | 75 | 74 |
| Watertown AP..... | 45 0 | 1746 | -27 | -20 | -16 | L | 93 | 90 | 87 | 26 | 76 | 74 | 73 |
| Yankton..... | 43 0 | 1280 | -18 | -11 | - 7 | M | 96 | 94 | 91 | 25 | 78 | 76 | 75 |
| TENNESSEE | | | | | | | | | | | | | |
| Athens..... | 33 3 | 940 | 10 | 14 | 18 | L | 96 | 94 | 91 | 22 | 77 | 76 | 75 |
| Bristol-Tri City AP..... | 36 3 | 1519 | -1 | 11 | 16 | L | 92 | 90 | 88 | 22 | 76 | 75 | 74 |
| Chattanooga AP..... | 35 0 | 670 | 11 | 15 | 19 | L | 97 | 94 | 92 | 22 | 78 | 78 | 77 |
| Clarksville..... | 36 4 | 470 | 6 | 12 | 16 | L | 98 | 96 | 94 | 21 | 79 | 78 | 77 |
| Columbia..... | 35 4 | 690 | 8 | 13 | 17 | L | 97 | 95 | 93 | 21 | 79 | 78 | 77 |
| Dyersburg..... | 36 0 | 334 | 7 | 13 | 17 | L | 98 | 96 | 94 | 21 | 80 | 79 | 78 |
| Greenville..... | 35 5 | 1320 | 5 | 10 | 14 | L | 93 | 91 | 88 | 22 | 76 | 75 | 74 |
| Jackson AP..... | 35 4 | 413 | 8 | 14 | 17 | L | 97 | 95 | 94 | 21 | 80 | 79 | 78 |
| Knoxville AP..... | 35 5 | 980 | 9 | 13 | 17 | L | 95 | 92 | 90 | 21 | 77 | 76 | 75 |
| Memphis AP..... | 35 0 | 263 | 11 | 17 | 21 | L | 98 | 96 | 94 | 21 | 80 | 79 | 78 |
| Murfreesboro..... | 35 5 | 608 | 7 | 13 | 17 | L | 97 | 94 | 92 | 22 | 79 | 78 | 77 |
| Nashville AP..... | 36 1 | 577 | 6 | 12 | 16 | L | 97 | 95 | 92 | 21 | 79 | 78 | 77 |
| Tulahoma..... | 35 2 | 1075 | 7 | 13 | 17 | L | 96 | 94 | 92 | 22 | 79 | 78 | 77 |
| TEXAS | | | | | | | | | | | | | |
| Abilene AP..... | 32 3 | 1759 | 12 | 17 | 21 | M | 101 | 99 | 97 | 22 | 76 | 75 | 74 |
| Alice AP..... | 27 4 | 180 | 26 | 30 | 34 | M | 101 | 99 | 97 | 20 | 81 | 80 | 79 |
| Amarillo AP..... | 35 1 | 3607 | 2 | 8 | 12 | M | 98 | 96 | 93 | 26 | 72 | 71 | 70 |
| Austin AP..... | 30 2 | 597 | 19 | 25 | 29 | M | 101 | 98 | 96 | 22 | 79 | 78 | 77 |
| Bay City..... | 29 0 | 52 | 25 | 29 | 33 | M | 95 | 93 | 91 | 16 | 81 | 80 | 79 |
| Beaumont..... | 30 0 | 18 | 25 | 29 | 33 | M | 96 | 94 | 93 | 19 | 81 | 80 | 79 |
| Beeville..... | 28 2 | 225 | 24 | 28 | 32 | M | 99 | 97 | 96 | 18 | 81 | 80 | 79 |
| Big Spring AP..... | 32 2 | 2537 | 12 | 18 | 22 | M | 100 | 98 | 96 | 26 | 75 | 73 | 72 |
| Brownsville AP..... | 25 5 | 16 | 32 | 36 | 40 | M | 94 | 92 | 91 | 18 | 80 | 80 | 79 |
| Brownwood..... | 31 5 | 1435 | 15 | 20 | 25 | M | 102 | 100 | 98 | 22 | 76 | 75 | 74 |
| Bryan AP..... | 30 4 | 275 | 22 | 27 | 31 | M | 100 | 98 | 96 | 20 | 79 | 78 | 78 |

Climatic Conditions for United States and Canada (Continued)*.a

| Col. 1 State and Station ^b | Col. 2 Latitude ^c | Col. 3 Elev., ^d ft | Winter | | | | Summer | | | | | | |
|--|---------------------------------|-------------------------------------|---|-----|------|---|---------------------------|-----|-----|---|---------------------------|-----|----|
| | | | Col. 4 | | | Col. 5 Coincident Wind Velocity ^e | Col. 6 Design Dry-Bulb | | | Col. 7 Out- door Daily Range ^f | Col. 8 Design Wet-Bulb | | |
| | | | Median of Annual Ex- tremes | 99% | 97½% | | 1% | 2½% | 5% | | 1% | 2½% | 5% |
| | | | | | | | | | | | | | |
| TEXAS (continued) | | | | | | | | | | | | | |
| Corpus Christi AP..... | 27 5 | 43 | 28 | 32 | 36 | M | 95 | 93 | 91 | 19 | 81 | 80 | 80 |
| Corsicana..... | 32 0 | 425 | 16 | 21 | 25 | M | 102 | 100 | 98 | 21 | 79 | 78 | 77 |
| Dallas AP..... | 32 5 | 481 | 14 | 19 | 24 | H | 101 | 99 | 97 | 20 | 79 | 78 | 78 |
| Del Rio, Laughlin AFB..... | 29 2 | 1072 | 24 | 28 | 31 | M | 101 | 99 | 98 | 24 | 79 | 77 | 76 |
| Denton..... | 33 1 | 655 | 12 | 18 | 22 | H | 102 | 100 | 98 | 22 | 79 | 78 | 77 |
| Eagle Pass..... | 28 5 | 743 | 23 | 27 | 31 | L | 106 | 104 | 102 | 24 | 80 | 79 | 78 |
| El Paso AP..... | 31 5 | 3918 | 16 | 21 | 25 | L | 100 | 98 | 96 | 27 | 70 | 69 | 68 |
| Fort Worth AP..... | 32 5 | 544r | 14 | 20 | 24 | H | 102 | 100 | 98 | 22 | 79 | 78 | 77 |
| Galveston AP..... | 29 2 | 5 | 28 | 32 | 36 | M | 91 | 89 | 88 | 10 | 82 | 81 | 81 |
| Greenville..... | 33 0 | 575 | 13 | 19 | 24 | H | 101 | 99 | 97 | 21 | 79 | 78 | 78 |
| Harlingen..... | 26 1 | 37 | 30 | 34 | 38 | M | 96 | 95 | 94 | 19 | 80 | 80 | 79 |
| Houston AP..... | 29 4 | 50 | 23 | 28 | 32 | M | 96 | 94 | 92 | 18 | 80 | 80 | 79 |
| Houston CO..... | 29 5 | 158r | 24 | 29 | 33 | M | 96 | 94 | 92 | 18 | 80 | 80 | 79 |
| Huntsville..... | 30 4 | 494 | 22 | 27 | 31 | M | 99 | 97 | 96 | 20 | 80 | 79 | 78 |
| Killeen-Gray AFB..... | 31 0 | 1021 | 17 | 22 | 26 | M | 100 | 99 | 97 | 22 | 78 | 77 | 76 |
| Lamesa..... | 32 5 | 2965 | 7 | 14 | 18 | M | 100 | 98 | 96 | 26 | 74 | 73 | 72 |
| Laredo AFB..... | 27 3 | 503 | 29 | 32 | 36 | L | 103 | 101 | 100 | 23 | 79 | 78 | 78 |
| Longview..... | 32 2 | 345 | 16 | 21 | 25 | M | 100 | 98 | 96 | 20 | 81 | 80 | 79 |
| Lubbock AP..... | 33 4 | 3243 | 4 | 11 | 15 | M | 99 | 97 | 94 | 26 | 73 | 72 | 71 |
| Lufkin AP..... | 31 1 | 286 | 19 | 24 | 28 | M | 98 | 96 | 95 | 20 | 81 | 80 | 79 |
| McAllen..... | 26 1 | 122 | 30 | 34 | 38 | M | 102 | 100 | 98 | 21 | 80 | 79 | 78 |
| Midland AP..... | 32 0 | 2815r | 13 | 19 | 23 | M | 100 | 98 | 96 | 26 | 74 | 73 | 72 |
| Mineral Wells AP..... | 32 5 | 934 | 12 | 18 | 22 | H | 102 | 100 | 98 | 22 | 78 | 77 | 76 |
| Palestine CO..... | 31 5 | 580 | 16 | 21 | 25 | M | 99 | 97 | 96 | 20 | 80 | 79 | 78 |
| Pampa..... | 35 3 | 3230 | 0 | 7 | 11 | M | 100 | 98 | 95 | 26 | 73 | 72 | 71 |
| Pecos..... | 31 2 | 2580 | 10 | 15 | 19 | L | 102 | 100 | 97 | 27 | 72 | 71 | 70 |
| Plainview..... | 34 1 | 3400 | 3 | 10 | 14 | M | 100 | 98 | 95 | 26 | 73 | 72 | 71 |
| Port Arthur AP..... | 30 0 | 16 | 25 | 29 | 33 | M | 94 | 92 | 91 | 19 | 81 | 80 | 80 |
| San Angelo, Goodfellow AFB..... | 31 2 | 1878 | 15 | 20 | 25 | M | 101 | 99 | 97 | 24 | 76 | 75 | 74 |
| San Antonio AP..... | 29 3 | 792 | 22 | 25 | 30 | L | 99 | 97 | 96 | 19 | 77 | 77 | 76 |
| Sherman-Perrin AFB..... | 33 4 | 763 | 12 | 18 | 23 | H | 101 | 99 | 97 | 22 | 79 | 78 | 77 |
| Snyder..... | 32 4 | 2325 | 9 | 15 | 19 | M | 102 | 100 | 97 | 26 | 75 | 74 | 73 |
| Temple..... | 31 1 | 675 | 18 | 23 | 27 | M | 101 | 99 | 97 | 22 | 79 | 78 | 77 |
| Tyler AP..... | 32 2 | 527 | 15 | 20 | 24 | M | 99 | 97 | 96 | 21 | 80 | 79 | 78 |
| Vernon..... | 34 1 | 1225 | 7 | 14 | 18 | H | 103 | 101 | 99 | 24 | 77 | 76 | 75 |
| Victoria AP..... | 28 5 | 104 | 24 | 28 | 32 | M | 98 | 96 | 95 | 18 | 80 | 79 | 79 |
| Waco AP..... | 31 4 | 500 | 16 | 21 | 26 | M | 101 | 99 | 98 | 22 | 79 | 78 | 78 |
| Wichita Falls AP..... | 34 0 | 994 | 9 | 15 | 19 | H | 103 | 100 | 98 | 24 | 77 | 76 | 75 |
| UTAH | | | | | | | | | | | | | |
| Cedar City AP..... | 37 4 | 5613 | -10 | -1 | 6 | VL | 94 | 91 | 89 | 32 | 65 | 64 | 62 |
| Logan..... | 41 4 | 4775 | -7 | 3 | 7 | VL | 93 | 91 | 89 | 33 | 66 | 65 | 63 |
| Moab..... | 38 5 | 3965 | 2 | 12 | 16 | VL | 100 | 98 | 95 | 30 | 66 | 65 | 64 |
| Ogden CO..... | 41 1 | 4400 | -3 | 7 | 11 | VL | 94 | 92 | 89 | 33 | 66 | 65 | 64 |
| Price..... | 39 4 | 5580 | -7 | 3 | 7 | L | 93 | 91 | 88 | 33 | 65 | 64 | 63 |
| Provo..... | 40 1 | 4470 | -6 | 2 | 6 | L | 96 | 93 | 91 | 32 | 67 | 66 | 65 |
| Richfield..... | 38 5 | 5300 | -10 | -1 | 3 | L | 94 | 92 | 89 | 34 | 66 | 65 | 64 |
| St. George CO..... | 37 1 | 2899 | 13 | 22 | 26 | VL | 104 | 102 | 99 | 33 | 71 | 70 | 69 |
| Salt Lake City AP..... | 40 5 | 4220 | -2 | 5 | 9 | L | 97 | 94 | 92 | 32 | 67 | 66 | 65 |
| Vernal AP..... | 40 3 | 5280 | -20 | -10 | -6 | VL | 90 | 88 | 84 | 32 | 64 | 63 | 62 |
| VERMONT | | | | | | | | | | | | | |
| Barre..... | 44 1 | 1120 | -23 | -17 | -13 | L | 86 | 84 | 81 | 23 | 73 | 72 | 70 |
| Burlington AP..... | 44 3 | 331 | -18 | -12 | -7 | M | 88 | 85 | 83 | 23 | 74 | 73 | 71 |
| Rutland..... | 43 3 | 620 | -18 | -12 | -8 | L | 87 | 85 | 82 | 23 | 74 | 73 | 71 |
| VIRGINIA | | | | | | | | | | | | | |
| Charlottesville..... | 38 1 | 870 | 7 | 11 | 15 | L | 93 | 90 | 88 | 23 | 79 | 77 | 76 |
| Danville AP..... | 36 3 | 590 | 9 | 13 | 17 | L | 95 | 92 | 90 | 21 | 78 | 77 | 76 |
| Fredericksburg..... | 38 2 | 50 | 6 | 10 | 14 | M | 94 | 92 | 89 | 21 | 79 | 78 | 76 |
| Harrisonburg..... | 38 3 | 1340 | 0 | 5 | 9 | L | 92 | 90 | 87 | 23 | 78 | 77 | 76 |
| Lynchburg AP..... | 37 2 | 947 | 10 | 15 | 19 | L | 94 | 92 | 89 | 21 | 77 | 76 | 75 |
| Norfolk AP..... | 36 5 | 26 | 18 | 20 | 23 | M | 94 | 91 | 89 | 18 | 79 | 78 | 78 |
| Petersburg..... | 37 1 | 194 | 10 | 15 | 18 | L | 96 | 94 | 91 | 20 | 80 | 79 | 78 |

Climatic Conditions for United States and Canada (Continued)*.a

| Col. 1 State and Station ^b | Col. 2 Latitude ^c | Col. 3 Elev. ^d Ft | Winter | | | | Summer | | | | | | |
|--|---------------------------------|------------------------------------|---|-----|------|---|---------------------------|-----|----|---|---------------------------|-----|----|
| | | | Col. 4 | | | Col. 5 Coinci- dent Wind Ve- locity ^e | Col. 6 Design Dry-Bulb | | | Col. 6 Out- door Daily Range ^f | Col. 8 Design Wet-Bulb | | |
| | | | Median of Annual Ex- tremes | 99% | 97½% | | 1% | 2½% | 5% | | 1% | 2½% | 5% |
| | | | | | | | | | | | | | |
| VIRGINIA (continued) | | | | | | | | | | | | | |
| Richmond AP..... | 37 3 | 162 | 10 | 14 | 18 | L | 96 | 93 | 91 | 21 | 79 | 78 | 77 |
| Roanoke AP..... | 37 2 | 1174 ^r | 9 | 15 | 18 | L | 94 | 91 | 89 | 23 | 76 | 75 | 74 |
| Staunton..... | 38 2 | 1480 | 3 | 8 | 12 | L | 92 | 90 | 87 | 23 | 78 | 77 | 75 |
| Winchester..... | 39 1 | 750 | 1 | 6 | 10 | L | 94 | 92 | 89 | 21 | 78 | 76 | 75 |
| WASHINGTON | | | | | | | | | | | | | |
| Aberdeen..... | 47 0 | 12 | 19 | 24 | 27 | M | 83 | 80 | 77 | 16 | 62 | 61 | 60 |
| Bellingham AP..... | 48 5 | 150 | 8 | 14 | 18 | L | 76 | 74 | 71 | 19 | 67 | 65 | 63 |
| Bremerton..... | 47 3 | 162 | 17 | 24 | 29 | L | 85 | 81 | 77 | 20 | 68 | 66 | 65 |
| Ellensburg AP..... | 47 0 | 1729 | - 5 | 2 | 6 | VL | 91 | 89 | 86 | 34 | 67 | 65 | 63 |
| Everett-Paine AFB..... | 47 5 | 598 | 13 | 19 | 24 | L | 82 | 78 | 74 | 20 | 67 | 65 | 63 |
| Kennewick..... | 46 0 | 392 | 4 | 11 | 15 | VL | 98 | 96 | 93 | 30 | 69 | 68 | 66 |
| Longview..... | 46 1 | 12 | 14 | 20 | 24 | L | 88 | 86 | 83 | 30 | 68 | 66 | 65 |
| Moses Lake, Larson AFB..... | 47 1 | 1183 | -14 | - 7 | - 1 | VL | 96 | 93 | 90 | 32 | 68 | 66 | 65 |
| Olympia AP..... | 47 0 | 190 | 15 | 21 | 25 | L | 85 | 83 | 80 | 32 | 67 | 65 | 63 |
| Port Angeles..... | 48 1 | 99 | 20 | 26 | 29 | M | 75 | 73 | 70 | 18 | 60 | 58 | 57 |
| Seattle-Boeing Fld..... | 47 3 | 14 | 17 | 23 | 27 | L | 82 | 80 | 77 | 24 | 67 | 65 | 64 |
| Seattle CO..... | 47 4 | 14 | 22 | 28 | 32 | L | 81 | 79 | 76 | 19 | 67 | 65 | 64 |
| Seattle-Tacoma AP..... | 47 3 | 386 | 14 | 20 | 24 | L | 85 | 81 | 77 | 22 | 66 | 64 | 63 |
| Spokane AP..... | 47 4 | 2357 | - 5 | - 2 | 4 | VL | 93 | 90 | 87 | 28 | 66 | 64 | 63 |
| Tacoma-McChord AFB..... | 47 1 | 350 | 14 | 20 | 24 | L | 85 | 81 | 78 | 22 | 68 | 66 | 64 |
| Walla Walla AP..... | 46 1 | 1185 | 5 | 12 | 16 | VL | 98 | 96 | 93 | 27 | 69 | 68 | 66 |
| Wenatchee..... | 47 2 | 634 | - 2 | 5 | 9 | VL | 95 | 92 | 89 | 32 | 68 | 66 | 64 |
| Yakima AP..... | 46 3 | 1061 | - 1 | 6 | 10 | VL | 94 | 92 | 89 | 36 | 69 | 67 | 65 |
| WEST VIRGINIA | | | | | | | | | | | | | |
| Beckley..... | 37 5 | 2330 | - 4 | 0 | 6 | L | 91 | 88 | 86 | 22 | 74 | 73 | 72 |
| Bluefield AP..... | 37 2 | 2850 | 1 | 6 | 10 | L | 88 | 86 | 83 | 22 | 74 | 73 | 72 |
| Charleston AP..... | 38 2 | 939 | 1 | 9 | 14 | L | 92 | 90 | 88 | 20 | 76 | 75 | 74 |
| Clarksburg..... | 39 2 | 977 | - 2 | 3 | 7 | L | 92 | 90 | 87 | 21 | 76 | 75 | 74 |
| Elkins AP..... | 38 5 | 1970 | - 4 | 1 | 5 | L | 87 | 84 | 82 | 22 | 74 | 73 | 72 |
| Huntington CO..... | 38 2 | 565 ^r | 4 | 10 | 14 | L | 95 | 93 | 91 | 22 | 77 | 76 | 75 |
| Martinsburg AP..... | 39 2 | 537 | 1 | 6 | 10 | L | 96 | 94 | 91 | 21 | 78 | 77 | 76 |
| Morgantown AP..... | 39 4 | 1245 | - 2 | 3 | 7 | L | 90 | 88 | 85 | 22 | 76 | 74 | 73 |
| Parkersburg CO..... | 39 2 | 615 ^r | 2 | 8 | 12 | L | 93 | 91 | 88 | 21 | 77 | 76 | 75 |
| Wheeling..... | 40 1 | 659 | 0 | 5 | 9 | L | 91 | 89 | 86 | 21 | 76 | 75 | 74 |
| WISCONSIN | | | | | | | | | | | | | |
| Appleton..... | 44 2 | 742 | -16 | -10 | - 6 | M | 89 | 87 | 84 | 23 | 75 | 74 | 72 |
| Ashland..... | 46 3 | 650 | -27 | -21 | -17 | L | 85 | 83 | 80 | 23 | 73 | 71 | 69 |
| Beloit..... | 42 3 | 780 | -13 | - 7 | - 3 | M | 92 | 90 | 87 | 24 | 77 | 76 | 75 |
| Eau Claire AP..... | 44 5 | 888 | -21 | -15 | -11 | L | 90 | 88 | 85 | 23 | 76 | 74 | 72 |
| Fond du Lac..... | 43 5 | 760 | -17 | -11 | - 7 | M | 89 | 87 | 84 | 23 | 76 | 74 | 73 |
| Green Bay AP..... | 44 3 | 683 | -16 | -12 | - 7 | M | 88 | 85 | 82 | 23 | 75 | 73 | 72 |
| La Crosse AP..... | 43 5 | 652 | -18 | -12 | - 8 | M | 90 | 88 | 85 | 22 | 78 | 76 | 75 |
| Madison AP..... | 43 1 | 858 | -13 | - 9 | - 5 | M | 92 | 88 | 85 | 22 | 77 | 75 | 73 |
| Manitowoc..... | 44 1 | 660 | -11 | - 5 | - 1 | M | 88 | 86 | 83 | 21 | 75 | 74 | 72 |
| Marinette..... | 45 0 | 605 | -14 | - 8 | - 4 | M | 88 | 86 | 83 | 20 | 74 | 72 | 70 |
| Milwaukee AP..... | 43 0 | 672 | -11 | - 6 | - 2 | M | 90 | 87 | 84 | 21 | 77 | 75 | 73 |
| Racine..... | 42 4 | 640 | -10 | - 4 | 0 | M | 90 | 88 | 85 | 21 | 77 | 75 | 73 |
| Sheboygan..... | 43 4 | 648 | -10 | - 4 | 0 | M | 89 | 87 | 84 | 20 | 76 | 74 | 72 |
| Stevens Point..... | 44 3 | 1079 | -22 | -16 | -12 | M | 89 | 87 | 84 | 23 | 75 | 73 | 71 |
| Waukesha..... | 43 0 | 860 | -12 | - 6 | - 2 | M | 91 | 89 | 86 | 22 | 77 | 75 | 74 |
| Wausau AP..... | 44 6 | 1196 | -24 | -18 | -14 | M | 89 | 86 | 83 | 23 | 74 | 72 | 70 |
| WYOMING | | | | | | | | | | | | | |
| Casper AP..... | 42 5 | 5319 | -20 | -11 | - 5 | L | 92 | 90 | 87 | 31 | 63 | 62 | 60 |
| Cheyenne AP..... | 41 1 | 6126 | -15 | - 6 | - 2 | M | 89 | 86 | 83 | 30 | 63 | 62 | 61 |
| Cody AP..... | 44 3 | 5090 | -23 | -13 | - 9 | L | 90 | 87 | 84 | 32 | 61 | 60 | 59 |
| Evanston..... | 41 2 | 6860 | -22 | -12 | - 8 | VL | 84 | 82 | 79 | 32 | 58 | 57 | 56 |
| Lander AP..... | 42 5 | 5563 | -26 | -16 | -12 | VL | 92 | 90 | 87 | 32 | 63 | 62 | 60 |
| Laramie AP..... | 41 2 | 7266 | -17 | - 6 | - 2 | M | 82 | 80 | 77 | 28 | 61 | 59 | 58 |
| Newcastle..... | 43 5 | 4480 | -18 | - 9 | - 5 | M | 92 | 89 | 86 | 30 | 68 | 67 | 66 |
| Rawlins..... | 41 5 | 6736 | -24 | -15 | -11 | L | 86 | 84 | 81 | 40 | 62 | 61 | 60 |
| Rock Springs AP..... | 41 4 | 6741 | -16 | - 6 | - 1 | VL | 86 | 84 | 82 | 32 | 58 | 57 | 56 |
| Sheridan AP..... | 44 5 | 3942 | -21 | -12 | - 7 | L | 95 | 92 | 89 | 32 | 67 | 65 | 64 |
| Torrington..... | 42 0 | 4098 | -20 | -11 | - 7 | M | 94 | 92 | 89 | 30 | 68 | 67 | 66 |

Climatic Conditions for United States and Canada (Continued)*.a

CANADA

| Col. 1 Province and Station ^b | Col. 2 Latitude ^c | Col. 3 Elev., ^d Ft | Winter | | | | Summer | | | | | | |
|---|---------------------------------|-------------------------------------|------------------------------|-----|------|--|---------------------------|-----|----|---|---------------------------|-----|----|
| | | | Col. 4 | | | Col. 5 Coincident Wind Ve- locity ^e | Col. 6 Design Dry-Bulb | | | Col. 7 Out- door Doily Range ^f | Col. 8 Design Wet-Bulb | | |
| | | | Average Annual Minimum | 99% | 97½% | | 1% | 2½% | 5% | | 1% | 2½% | 5% |
| | | | | | | | | | | | | | |
| ALBERTA | | | | | | | | | | | | | |
| Calgary AP..... | 51 1 | 3540 | -30 | -29 | -25 | M | 87 | 85 | 82 | 26 | 66 | 64 | 63 |
| Edmonton AP..... | 53 3 | 2219 | -30 | -29 | -26 | VL | 86 | 83 | 80 | 23 | 69 | 67 | 65 |
| Grande Prairie AP..... | 55 1 | 2190 | -44 | -43 | -37 | VL | 84 | 81 | 78 | 23 | 66 | 64 | 63 |
| Jasper CO..... | 52 5 | 3480 | -38 | -32 | -28 | VL | 87 | 84 | 81 | 28 | 66 | 64 | 63 |
| Lethbridge AP..... | 49 4 | 3018 | -31 | -31 | -24 | M | 91 | 88 | 85 | 28 | 68 | 66 | 64 |
| McMurray AP..... | 56 4 | 1216 | -44 | -42 | -39 | VL | 87 | 84 | 81 | 28 | 69 | 67 | 65 |
| Medicine Hat AP..... | 50 0 | 2365 | -33 | -30 | -26 | M | 96 | 93 | 90 | 28 | 72 | 69 | 67 |
| Red Deer AP..... | 52 1 | 2965 | -38 | -33 | -28 | VL | 88 | 86 | 83 | 25 | 67 | 65 | 64 |
| BRITISH COLUMBIA | | | | | | | | | | | | | |
| Dawson Creek..... | 55 5 | 2200 | -47 | -40 | -35 | L | 84 | 81 | 78 | 25 | 66 | 64 | 63 |
| Fort Nelson AP..... | 58 5 | 1230 | -43 | -44 | -41 | VL | 87 | 84 | 81 | 23 | 66 | 64 | 63 |
| Kamloops CO..... | 50 4 | 1150 | -15 | -16 | -10 | VL | 97 | 94 | 91 | 31 | 71 | 69 | 68 |
| Nanaimo CO..... | 49 1 | 100 | 16 | 17 | 20 | VL | 81 | 78 | 75 | 20 | 66 | 64 | 62 |
| New Westminster CO..... | 49 1 | 50 | 12 | 15 | 19 | VL | 86 | 84 | 82 | 20 | 68 | 66 | 65 |
| Penticton AP..... | 49 3 | 1121 | 0 | -1 | 3 | L | 94 | 91 | 88 | 31 | 71 | 69 | 68 |
| Prince George AP..... | 53 5 | 2218 | -38 | -37 | -31 | VL | 85 | 82 | 79 | 26 | 68 | 65 | 63 |
| Prince Rupert CO..... | 54 2 | 170 | 9 | 11 | 15 | L | 73 | 71 | 69 | 13 | 62 | 60 | 59 |
| Trail..... | 49 1 | 1400 | -3 | -2 | 3 | VL | 94 | 91 | 88 | 30 | 70 | 68 | 67 |
| Vancouver AP..... | 49 1 | 16 | 13 | 15 | 19 | L | 80 | 78 | 76 | 17 | 68 | 66 | 65 |
| Victoria CO..... | 48 3 | 228 | 20 | 20 | 23 | M | 80 | 76 | 72 | 16 | 64 | 62 | 60 |
| MANITOBA | | | | | | | | | | | | | |
| Brandon CO..... | 49 5 | 1200 | -36 | -29 | -26 | M | 90 | 87 | 84 | 26 | 75 | 73 | 71 |
| Churchill AP..... | 58 5 | 115 | -43 | -40 | -38 | H | 79 | 75 | 72 | 18 | 68 | 66 | 63 |
| Dauphin AP..... | 51 1 | 999 | -35 | -29 | -26 | M | 89 | 86 | 83 | 24 | 74 | 72 | 70 |
| Flin Flon CO..... | 54 5 | 1098 | -38 | -40 | -36 | L | 85 | 81 | 78 | 19 | 71 | 69 | 67 |
| Portage la Prairie AP..... | 49 5 | 867 | -28 | -25 | -22 | M | 90 | 87 | 84 | 22 | 75 | 74 | 72 |
| The Pas AP..... | 54 0 | 894 | -41 | -35 | -32 | M | 85 | 81 | 78 | 20 | 73 | 71 | 69 |
| Winnipeg AP..... | 49 5 | 786 | -31 | -28 | -25 | M | 90 | 87 | 84 | 23 | 75 | 74 | 72 |
| NEW BRUNSWICK | | | | | | | | | | | | | |
| Campbellton CO..... | 48 0 | 25 | -20 | -18 | -14 | L | 87 | 84 | 81 | 20 | 74 | 71 | 69 |
| Chatham AP..... | 47 0 | 112 | -17 | -15 | -10 | M | 90 | 87 | 84 | 22 | 74 | 71 | 69 |
| Edmundston CO..... | 47 2 | 500 | -29 | -20 | -16 | M | 84 | 81 | 78 | 21 | 75 | 72 | 70 |
| Fredericton AP..... | 45 5 | 74 | -19 | -16 | -10 | L | 89 | 86 | 83 | 23 | 73 | 70 | 68 |
| Moncton AP..... | 46 1 | 248 | -16 | -12 | -7 | H | 88 | 85 | 82 | 21 | 74 | 71 | 69 |
| Saint John AP..... | 45 2 | 352 | -15 | -12 | -7 | M | 81 | 79 | 77 | 18 | 71 | 68 | 66 |
| NEWFOUNDLAND | | | | | | | | | | | | | |
| Corner Brook CO..... | 49 0 | 40 | -9 | -10 | -5 | H | 84 | 81 | 79 | 18 | 69 | 68 | 66 |
| Gander AP..... | 49 0 | 482 | -5 | -5 | -1 | H | 85 | 82 | 79 | 20 | 69 | 68 | 66 |
| Goose Bay AP..... | 53 2 | 144 | -28 | -27 | -25 | M | 86 | 81 | 77 | 18 | 69 | 67 | 65 |
| St. John's AP..... | 47 4 | 463 | 1 | 2 | 6 | H | 79 | 77 | 75 | 17 | 69 | 68 | 66 |
| Stephenville..... | 48 3 | 44 | -4 | -6 | -1 | H | 79 | 76 | 74 | 13 | 69 | 68 | 66 |
| NORTHWEST TERRITORIES | | | | | | | | | | | | | |
| Fort Smith AP..... | 60 0 | 665 | -51 | -49 | -46 | VL | 85 | 83 | 80 | 25 | 67 | 65 | 64 |
| Frobisher Bay AP..... | 63 5 | 68 | -45 | -45 | -42 | H | 63 | 59 | 56 | 14 | | | |
| Inuvik..... | 68 2 | 75 | -54 | -50 | -48 | VL | 80 | 77 | 75 | 23 | 63 | 61 | 60 |
| Resolute AP..... | 74 4 | 209 | -52 | -49 | -47 | M | 54 | 51 | 49 | 10 | | | |
| Yellowknife AP..... | 62 3 | 682 | -51 | -49 | -47 | VL | 78 | 76 | 74 | 17 | 65 | 63 | 62 |
| NOVA SCOTIA | | | | | | | | | | | | | |
| Amherst..... | 45 5 | 63 | -15 | -10 | -5 | H | 85 | 82 | 79 | 21 | 72 | 70 | 68 |
| Halifax AP..... | 44 4 | 136 | -4 | 0 | 4 | H | 83 | 80 | 77 | 16 | 69 | 68 | 67 |
| Kentville CO..... | 45 0 | 50 | -8 | -4 | 0 | M | 86 | 83 | 80 | 23 | 72 | 70 | 69 |
| New Glasgow..... | 45 4 | 317 | -16 | -10 | -5 | H | 84 | 81 | 79 | 21 | 72 | 70 | 68 |
| Sydney AP..... | 46 1 | 197 | -3 | 0 | 5 | H | 84 | 82 | 80 | 20 | 72 | 70 | 68 |
| Truro CO..... | 45 2 | 77 | -17 | -12 | -7 | M | 84 | 81 | 79 | 22 | 72 | 70 | 69 |
| Yarmouth AP..... | 43 5 | 136 | 2 | 5 | 9 | H | 76 | 73 | 71 | 15 | 69 | 68 | 67 |
| ONTARIO | | | | | | | | | | | | | |
| Belleville CO..... | 44 1 | 250 | -15 | -11 | -7 | M | 89 | 86 | 84 | 21 | 77 | 75 | 73 |
| Chatham CO..... | 42 2 | 600 | -1 | 3 | 6 | M | 92 | 90 | 88 | 20 | 77 | 75 | 74 |
| Cornwall..... | 45 0 | 210 | -22 | -14 | -9 | M | 89 | 86 | 84 | 23 | 77 | 75 | 74 |
| Fort William AP..... | 48 2 | 644 | -31 | -27 | -23 | L | 86 | 83 | 80 | 23 | 72 | 70 | 68 |
| Hamilton..... | 43 2 | 303 | -2 | 0 | 3 | M | 91 | 88 | 86 | 21 | 77 | 75 | 73 |
| Kapuskasing AP..... | 49 3 | 752 | -37 | -31 | -28 | M | 87 | 84 | 81 | 23 | 73 | 71 | 69 |
| Kenora AP..... | 49 5 | 1345 | -33 | -31 | -28 | M | 86 | 83 | 80 | 20 | 75 | 73 | 71 |
| Kingston CO..... | 44 2 | 300 | -16 | -10 | -7 | M | 85 | 82 | 80 | 20 | 77 | 75 | 73 |

Climatic Conditions for United States and Canada (Concluded)*,a

| Col. 1 Province and Station ^b | Col. 2 Latitude ^c | Col. 3 Elev. ^d Ft | Winter | | | | Summer | | | | | | |
|---|---------------------------------|------------------------------------|-----------------------------------|-----|------|---|---------------------------|-----|----|---|---------------------------|-----|----|
| | | | Col. 4 | | | Col. 5 Coinci- dent Wind Ve- locity ^e | Col. 6 Design Dry-Bulb | | | Col. 7 Out- door Daily Range ^f | Col. 8 Design Wet-Bulb | | |
| | | | Average Annual Mini- mum | 99% | 97½% | | 1% | 2½% | 5% | | 1% | 2½% | 5% |
| | | | | | | | | | | | | | |
| ONTARIO (continued) | | | | | | | | | | | | | |
| Kitchener..... | 43 3 | 1125 | -11 | - 3 | 1 | M | 88 | 85 | 83 | 24 | 76 | 75 | 74 |
| London AP..... | 43 0 | 912 | - 9 | - 1 | 3 | M | 90 | 88 | 86 | 22 | 76 | 75 | 74 |
| North Bay AP..... | 46 2 | 1210 | -27 | -21 | -17 | M | 87 | 84 | 82 | 18 | 71 | 70 | 69 |
| Oshawa..... | 43 5 | 370 | -11 | - 5 | - 2 | M | 90 | 87 | 85 | 21 | 77 | 75 | 73 |
| Ottawa AP..... | 45 2 | 339 | -21 | -17 | -13 | M | 90 | 87 | 84 | 21 | 75 | 74 | 73 |
| Owen Sound..... | 44 3 | 597 | - 9 | - 5 | - 1 | M | 87 | 84 | 82 | 21 | 74 | 72 | 71 |
| Peterborough CO..... | 44 2 | 648 | -20 | -13 | - 9 | M | 90 | 87 | 85 | 22 | 76 | 74 | 73 |
| St. Catharines CO..... | 43 1 | 325 | 1 | 2 | 5 | M | 91 | 88 | 86 | 20 | 77 | 75 | 73 |
| Sarnia..... | 43 0 | 625 | - 6 | 2 | 6 | M | 92 | 90 | 88 | 19 | 76 | 74 | 73 |
| Sault Ste. Marie CO..... | 46 3 | 675 | -21 | -20 | -15 | M | 88 | 85 | 83 | 22 | 72 | 70 | 68 |
| Sudbury..... | 46 3 | 850 | -25 | -20 | -15 | VL | 89 | 86 | 84 | 25 | 72 | 70 | 69 |
| Timmins CO..... | 48 3 | 1100 | -37 | -33 | -28 | M | 90 | 87 | 84 | 24 | 73 | 71 | 69 |
| Toronto AP..... | 43 4 | 578 | -10 | - 3 | 1 | M | 90 | 87 | 85 | 22 | 77 | 75 | 73 |
| Windsor AP..... | 42 2 | 637 | - 1 | 4 | 7 | M | 92 | 90 | 88 | 20 | 77 | 75 | 74 |
| PRINCE EDWARD ISLAND | | | | | | | | | | | | | |
| Charlottetown AP..... | 46 2 | 186 | -11 | - 6 | - 3 | H | 84 | 81 | 79 | 16 | 72 | 70 | 68 |
| Summerside AP..... | 46 3 | 78 | -10 | - 8 | - 3 | H | 84 | 81 | 79 | 16 | 72 | 70 | 68 |
| QUEBEC | | | | | | | | | | | | | |
| Bagotville..... | 48 2 | 536 | -35 | -26 | -22 | VL | 88 | 84 | 81 | 20 | 72 | 71 | 69 |
| Chicoutimi CO..... | 48 3 | 150 | -31 | -24 | -20 | VL | 87 | 83 | 80 | 20 | 72 | 71 | 69 |
| Drummondville CO..... | 45 5 | 270 | -26 | -18 | -13 | M | 88 | 85 | 82 | 22 | 76 | 74 | 72 |
| Granby..... | 45 2 | 550 | -23 | -17 | -12 | L | 87 | 84 | 82 | 21 | 76 | 74 | 72 |
| Hull..... | 45 3 | 200 | -21 | -17 | -13 | M | 90 | 87 | 84 | 21 | 75 | 74 | 73 |
| Mégantic AP..... | 45 4 | 1362 | -27 | -20 | -16 | M | 84 | 81 | 78 | 19 | 75 | 73 | 71 |
| Montréal AP..... | 45 3 | 98 | -20 | -16 | -10 | M | 88 | 86 | 84 | 18 | 76 | 74 | 73 |
| Québec AP..... | 46 5 | 245 | -25 | -19 | -13 | M | 86 | 82 | 79 | 21 | 75 | 73 | 71 |
| Rimouski..... | 48 3 | 117 | -18 | -16 | -12 | H | 78 | 74 | 71 | 18 | 71 | 69 | 68 |
| St. Jean..... | 45 2 | 129 | -21 | -15 | -10 | M | 87 | 85 | 83 | 20 | 76 | 74 | 73 |
| St. Jérôme..... | 45 5 | 310 | -30 | -18 | -13 | L | 87 | 84 | 82 | 23 | 76 | 74 | 73 |
| Sept Îles AP..... | 50 1 | 190 | -29 | -27 | -22 | L | 80 | 78 | 75 | 17 | 66 | 64 | 63 |
| Shawinigan..... | 46 3 | 306 | -27 | -20 | -15 | L | 88 | 85 | 83 | 21 | 76 | 74 | 72 |
| Sherbrooke CO..... | 45 2 | 595 | -25 | -18 | -13 | L | 87 | 84 | 81 | 20 | 75 | 73 | 71 |
| Thetford Mines..... | 46 0 | 1020 | -25 | -19 | -14 | M | 86 | 83 | 80 | 22 | 75 | 73 | 71 |
| Trois Rivières CO..... | 46 2 | 200 | -30 | -18 | -13 | M | 88 | 85 | 82 | 23 | 76 | 74 | 72 |
| Val d'Or AP..... | 48 0 | 1108 | -37 | -31 | -27 | L | 88 | 85 | 82 | 22 | 72 | 71 | 69 |
| Valleyfield..... | 45 2 | 150 | -20 | -14 | - 9 | M | 87 | 85 | 83 | 21 | 76 | 74 | 73 |
| SASKATCHEWAN | | | | | | | | | | | | | |
| Estevan AP..... | 49 0 | 1884 | -32 | -30 | -25 | M | 93 | 89 | 86 | 25 | 75 | 73 | 71 |
| Moose Jaw AP..... | 50 2 | 1857 | -33 | -32 | -27 | M | 93 | 89 | 86 | 27 | 73 | 71 | 69 |
| North Battleford AP..... | 52 5 | 1796 | -33 | -33 | -29 | L | 90 | 86 | 83 | 25 | 71 | 69 | 67 |
| Prince Albert AP..... | 53 1 | 1414 | -45 | -41 | -35 | VL | 88 | 84 | 81 | 25 | 72 | 70 | 68 |
| Regina AP..... | 50 3 | 1884 | -38 | -34 | -29 | M | 92 | 88 | 85 | 27 | 73 | 71 | 69 |
| Saskatoon AP..... | 52 1 | 1645 | -37 | -34 | -30 | M | 90 | 86 | 83 | 25 | 71 | 69 | 67 |
| Swift Current AP..... | 50 2 | 2677 | -31 | -29 | -25 | M | 93 | 89 | 86 | 24 | 72 | 70 | 68 |
| Yorkton AP..... | 51 2 | 1653 | -38 | -33 | -28 | M | 89 | 85 | 82 | 23 | 74 | 72 | 70 |
| YUKON TERRITORY | | | | | | | | | | | | | |
| Whitehorse AP..... | 60 4 | 2289 | -45 | -45 | -42 | VL | 78 | 75 | 72 | 22 | 62 | 60 | 59 |

* Data for U. S. stations extracted from *Evaluated Weather Data for Cooling Equipment Design, Addendum No. 1, Winter and Summer Data*, with the permission of the publisher, Fluor Products Company, Inc., Box 1267, Santa Rosa, California.

^a Data compiled from official weather stations, where hourly weather observations are made by trained observers, and from other sources. Table 1 prepared by ASHRAE Technical Committee 2.2. Weather Data and Design Conditions. Percentage of winter design data show the percent of 3-month period, December through February. Canadian data are based on January only. Percentage of summer design data show the percent of 4-month period, June through September. Canadian data are based on July only. Also see References 1 to 7.

^b When airport temperature observations were used to develop design data, "AP" follows station name, and "AFB" follows Air Force Bases. Data for stations followed by "CO" came from office locations within an urban area and generally reflect an influence of the surrounding area. Stations without designation can be considered semi-rural and may be directly compared with most airport data.

^c Latitude is given to the nearest 10 minutes, for use in calculating solar loads. For example, the latitude for Anniston, Alabama is given as 33 4, or 33°40'.

^d Elevations are ground elevations for each station as of 1964. Temperature readings are generally made at an elevation of 5 ft above ground, except for locations marked r, indicating roof exposure of thermometer.

^e Coincident wind velocities derived from approximately coldest 600 hours out of 20,000 hours of December through February data per station. Also see References 5 and 6. The four classifications are:

VL = Very Light, 70 percent or more of cold extreme hours ≤ 7 mph. M = Moderate, 50 to 74 percent cold extreme hours > 7 mph.

L = Light, 50 to 69 percent cold extreme hours ≤ 7 mph. H = High, 75 percent or more cold extreme hours > 7 mph., and 50 percent are > 12 mph.

^f The difference between the average maximum and average minimum temperatures during the warmest month.

[†] More detailed data on Arizona, California, and Nevada may be found in *Recommended Design Temperatures, Northern California*, published by the Golden Gate Chapter; and *Recommended Design Temperatures, Southern California, Arizona, Nevada*, published by the Southern California Chapter.

Climatic Conditions for Other Foreign Countries

| Col. 1 Country and Station | Col. 2 Latitude and Longitude | Col. 3 Elevation, Ft | Winter | | | Summer | | | | | | | | |
|-------------------------------|----------------------------------|-------------------------|--------------------------|-----|------|---------------------------|-----|-----|--------------------------------------|---------------------------|-----|----|--|--|
| | | | Col. 4 | | | Col. 5 Design Dry-Bulb | | | Col. 6 Out-door Daily Range F deg | Col. 7 Design Wet-Bulb | | | | |
| | | | Mean of Annual Ex-tremes | 99% | 97½% | 1% | 2½% | 5% | | 1% | 2½% | 5% | | |
| | | | | | | | | | | | | | | |
| ADEN | | | | | | | | | | | | | | |
| Aden..... | 12 50N/45 02E | 10 | 63 | 68 | 70 | 102 | 100 | 98 | 11 | 83 | 82 | 82 | | |
| AFGHANISTAN | | | | | | | | | | | | | | |
| Kabul..... | 34 35N/69 12E | 5955 | 2 | 6 | 9 | 98 | 96 | 93 | 32 | 66 | 65 | 64 | | |
| ALGERIA | | | | | | | | | | | | | | |
| Algiers..... | 36 46N/3 03E | 194 | 38 | 43 | 45 | 95 | 92 | 89 | 14 | 77 | 76 | 75 | | |
| ARGENTINA | | | | | | | | | | | | | | |
| Buenos Aires..... | 34 35S/58 29W | 89 | 27 | 32 | 34 | 91 | 89 | 86 | 22 | 77 | 76 | 75 | | |
| Córdoba..... | 31 22S/64 15W | 1388 | 21 | 28 | 32 | 100 | 96 | 93 | 27 | 76 | 75 | 74 | | |
| Tucuman..... | 26 50S/65 10W | 1401 | 24 | 32 | 36 | 102 | 99 | 96 | 23 | 76 | 75 | 74 | | |
| AUSTRALIA | | | | | | | | | | | | | | |
| Adelaide..... | 34 56S/138 35E | 140 | 36 | 38 | 40 | 98 | 94 | 91 | 25 | 72 | 70 | 68 | | |
| Alice Springs..... | 23 48S/133 53E | 1795 | 28 | 34 | 37 | 104 | 102 | 100 | 27 | 75 | 74 | 72 | | |
| Brisbane..... | 27 28S/153 02E | 137 | 39 | 44 | 47 | 91 | 88 | 86 | 18 | 77 | 76 | 75 | | |
| Darwin..... | 12 28S/130 51E | 88 | 60 | 64 | 66 | 94 | 93 | 91 | 16 | 82 | 81 | 81 | | |
| Melbourne..... | 37 49S/144 58E | 114 | 31 | 35 | 38 | 95 | 91 | 86 | 21 | 71 | 69 | 68 | | |
| Perth..... | 31 57S/115 51E | 210 | 38 | 40 | 42 | 100 | 96 | 93 | 22 | 76 | 74 | 73 | | |
| Sydney..... | 33 52S/151 12E | 138 | 38 | 40 | 42 | 89 | 84 | 80 | 13 | 74 | 73 | 72 | | |
| AUSTRIA | | | | | | | | | | | | | | |
| Vienna..... | 48 15N/16 22E | 644 | - 2 | 6 | 11 | 88 | 86 | 83 | 16 | 71 | 69 | 67 | | |
| AZORES | | | | | | | | | | | | | | |
| Lajes (Terceira)..... | 38 45N/27 05W | 170 | 42 | 46 | 49 | 80 | 78 | 77 | 11 | 73 | 72 | 71 | | |
| BAHAMAS | | | | | | | | | | | | | | |
| Nassau..... | 25 05N/77 21W | 11 | 55 | 61 | 63 | 90 | 89 | 88 | 13 | 80 | 80 | 79 | | |
| BELGIUM | | | | | | | | | | | | | | |
| Brussels..... | 50 48N/4 21E | 328 | 13 | 15 | 19 | 83 | 79 | 77 | 19 | 70 | 68 | 67 | | |
| BERMUDA | | | | | | | | | | | | | | |
| Kindley AFB..... | 33 22N/64 41W | 129 | 47 | 53 | 55 | 87 | 86 | 85 | 12 | 79 | 78 | 78 | | |
| BOLIVIA | | | | | | | | | | | | | | |
| La Paz..... | 16 30S/68 09W | 12001 | 28 | 31 | 33 | 71 | 69 | 68 | 24 | 58 | 57 | 56 | | |
| BRAZIL | | | | | | | | | | | | | | |
| Belem..... | 1 27S/48 29W | 42 | 67 | 70 | 71 | 90 | 89 | 87 | 19 | 80 | 79 | 78 | | |
| Belo Horizonte..... | 19 56S/43 57W | 3002 | 42 | 47 | 50 | 86 | 84 | 83 | 18 | 76 | 75 | 75 | | |
| Brasilia..... | 15 52S/47 55W | 3442 | 46 | 49 | 51 | 89 | 88 | 86 | 17 | 76 | 75 | 75 | | |
| Curitiba..... | 25 25S/49 17W | 3114 | 28 | 34 | 37 | 86 | 84 | 82 | 21 | 75 | 74 | 74 | | |
| Fortaleza..... | 3 46S/38 33W | 89 | 66 | 69 | 70 | 91 | 90 | 89 | 17 | 79 | 78 | 78 | | |
| Porto Alegre..... | 30 02S/51 13W | 33 | 32 | 37 | 40 | 95 | 92 | 89 | 20 | 76 | 76 | 75 | | |
| Recife..... | 8 04S/34 53W | 97 | 67 | 69 | 70 | 88 | 87 | 86 | 10 | 78 | 77 | 77 | | |
| Rio de Janeiro..... | 22 55S/43 12W | 201 | 56 | 58 | 60 | 94 | 92 | 90 | 11 | 80 | 79 | 78 | | |
| Salvador..... | 13 00S/38 30W | 154 | 65 | 67 | 68 | 88 | 87 | 86 | 12 | 79 | 79 | 78 | | |
| São Paulo..... | 23 33S/46 38W | 2608 | 36 | 42 | 46 | 86 | 84 | 82 | 18 | 75 | 74 | 74 | | |
| BRITISH HONDURAS | | | | | | | | | | | | | | |
| Belize..... | 17 31N/88 11W | 17 | 55 | 60 | 62 | 90 | 90 | 89 | 13 | 82 | 82 | 81 | | |
| BULGARIA | | | | | | | | | | | | | | |
| Sofia..... | 42 42N/23 20E | 1805 | - 2 | 3 | 8 | 89 | 86 | 84 | 26 | 71 | 70 | 69 | | |
| BURMA | | | | | | | | | | | | | | |
| Mandalay..... | 21 59N/96 06E | 252 | 50 | 54 | 56 | 104 | 102 | 101 | 30 | 81 | 80 | 80 | | |
| Rangoon..... | 16 47N/96 09E | 18 | 59 | 62 | 63 | 100 | 98 | 95 | 25 | 83 | 82 | 82 | | |
| CAMBODIA | | | | | | | | | | | | | | |
| Phnom Penh..... | 11 33N/104 51E | 36 | 62 | 66 | 68 | 98 | 96 | 94 | 19 | 83 | 82 | 82 | | |
| CEYLON | | | | | | | | | | | | | | |
| Colombo..... | 6 54N/79 52E | 24 | 65 | 69 | 70 | 90 | 89 | 88 | 15 | 81 | 80 | 80 | | |
| CHILE | | | | | | | | | | | | | | |
| Punta Arenas..... | 53 10S/70 54W | 26 | 22 | 25 | 27 | 68 | 66 | 64 | 14 | 56 | 55 | 54 | | |
| Santiago..... | 33 27S/70 42W | 1706 | 27 | 32 | 35 | 90 | 89 | 88 | 32 | 71 | 70 | 69 | | |
| Valparaiso..... | 33 01S/71 38W | 135 | 39 | 43 | 46 | 81 | 79 | 77 | 16 | 67 | 66 | 65 | | |
| CHINA | | | | | | | | | | | | | | |
| Chungking..... | 29 33N/106 33E | 755 | 34 | 37 | 39 | 99 | 97 | 95 | 18 | 81 | 80 | 79 | | |
| Shanghai..... | 31 12N/121 26E | 23 | 16 | 23 | 26 | 94 | 92 | 90 | 16 | 81 | 81 | 80 | | |
| COLOMBIA | | | | | | | | | | | | | | |
| Baranquilla..... | 10 59N/74 48W | 44 | 66 | 70 | 72 | 95 | 94 | 93 | 17 | 83 | 82 | 82 | | |
| Bogotá..... | 4 36N/74 05W | 8406 | 42 | 45 | 46 | 72 | 70 | 69 | 19 | 60 | 59 | 58 | | |
| Cali..... | 3 25N/76 30W | 3189 | 53 | 57 | 58 | 84 | 82 | 79 | 15 | 70 | 69 | 68 | | |
| Medellin..... | 6 13N/75 36W | 4650 | 48 | 53 | 55 | 87 | 85 | 84 | 25 | 73 | 72 | 72 | | |
| CONGO | | | | | | | | | | | | | | |
| Brazzaville..... | 4 15S/15 15E | 1043 | 54 | 60 | 62 | 93 | 92 | 91 | 21 | 81 | 81 | 80 | | |
| Kinasha (Leopoldville)..... | 4 20S/15 18E | 1066 | 54 | 60 | 62 | 92 | 91 | 90 | 19 | 81 | 80 | 80 | | |
| Stanleyville..... | 0 26N/15 14E | 1370 | 65 | 67 | 68 | 92 | 91 | 90 | 19 | 81 | 80 | 80 | | |

Climatic Conditions for Other Foreign Countries (Continued)

| Col. 1 Country and Station | Col. 2 Latitude and Longitude | Col. 3 Elevation, Ft | Winter | | | Summer | | | | | | | | |
|-------------------------------|----------------------------------|-------------------------|---------------------------------------|-----|------|---------------------------|-----|-----|--|---------------------------|-----|----|--|--|
| | | | Col. 4 | | | Col. 5 Design Dry-Bulb | | | Col. 6 Outdoor Daily Range F deg | Col. 7 Design Wet-Bulb | | | | |
| | | | Mean of Annual Ex- tremes | 99% | 97½% | 1% | 2½% | 5% | | 1% | 2½% | 5% | | |
| CUBA | | | | | | | | | | | | | | |
| Guantanamo Bay..... | 19 54N/75 09W | 21 | 60 | 64 | 66 | 94 | 93 | 92 | 16 | 82 | 81 | 80 | | |
| Havana..... | 23 08N/82 21W | 80 | 54 | 59 | 62 | 92 | 91 | 89 | 14 | 81 | 81 | 80 | | |
| CZECHOSLOVAKIA | | | | | | | | | | | | | | |
| Prague..... | 50 05N/14 25E | 662 | 3 | 4 | 9 | 88 | 85 | 83 | 16 | 66 | 65 | 64 | | |
| DENMARK | | | | | | | | | | | | | | |
| Copenhagen..... | 55 41N/12 33E | 43 | 11 | 16 | 19 | 79 | 76 | 74 | 17 | 68 | 66 | 64 | | |
| DOMINICAN REPUBLIC | | | | | | | | | | | | | | |
| Santo Domingo..... | 18 29N/69 54W | 57 | 61 | 63 | 65 | 92 | 90 | 88 | 16 | 81 | 80 | 80 | | |
| ECUADOR | | | | | | | | | | | | | | |
| Guayaquil..... | 2 10S/79 53W | 20 | 61 | 64 | 65 | 92 | 91 | 89 | 20 | 80 | 80 | 79 | | |
| Quito..... | 0 13S/78 32W | 9446 | 30 | 36 | 39 | 73 | 72 | 71 | 32 | 63 | 62 | 62 | | |
| EL SALVADOR | | | | | | | | | | | | | | |
| San Salvador..... | 13 42N/89 13W | 2238 | 51 | 54 | 56 | 98 | 96 | 95 | 32 | 77 | 76 | 75 | | |
| ETHIOPIA | | | | | | | | | | | | | | |
| Addis Ababa..... | 9 02N/38 45E | 7753 | 35 | 39 | 41 | 84 | 82 | 81 | 28 | 66 | 65 | 64 | | |
| Asmara..... | 15 17N/38 55E | 7628 | 36 | 40 | 42 | 83 | 81 | 80 | 27 | 65 | 64 | 63 | | |
| FINLAND | | | | | | | | | | | | | | |
| Helsinki..... | 60 10N/24 57E | 30 | -11 | -7 | -1 | 77 | 74 | 72 | 14 | 66 | 65 | 63 | | |
| FRANCE | | | | | | | | | | | | | | |
| Lyon..... | 45 42N/4 47E | 938 | -1 | 10 | 14 | 91 | 89 | 86 | 23 | 71 | 70 | 69 | | |
| Marseilles..... | 43 18N/5 23E | 246 | 23 | 25 | 28 | 90 | 87 | 84 | 22 | 72 | 71 | 69 | | |
| Nantes..... | 47 15N/1 34W | 121 | 17 | 22 | 26 | 86 | 83 | 80 | 21 | 70 | 69 | 67 | | |
| Nice..... | 43 42N/7 16E | 39 | 31 | 34 | 37 | 87 | 85 | 83 | 15 | 73 | 72 | 72 | | |
| Paris..... | 48 49N/2 29E | 164 | 16 | 22 | 25 | 89 | 86 | 83 | 21 | 70 | 68 | 67 | | |
| Strasbourg..... | 48 35N/7 46E | 465 | 9 | 11 | 16 | 86 | 83 | 80 | 20 | 70 | 69 | 67 | | |
| FRENCH GUIANA | | | | | | | | | | | | | | |
| Cayenne..... | 4 56N/52 27W | 20 | 69 | 71 | 72 | 92 | 91 | 90 | 17 | 83 | 83 | 82 | | |
| GERMANY | | | | | | | | | | | | | | |
| Berlin..... | 52 27N/13 18E | 187 | 6 | 7 | 12 | 84 | 81 | 78 | 19 | 68 | 67 | 66 | | |
| Hamburg..... | 53 33N/9 58E | 66 | 10 | 12 | 16 | 80 | 76 | 73 | 13 | 68 | 66 | 65 | | |
| Hannover..... | 52 24N/9 40E | 561 | 7 | 16 | 20 | 82 | 78 | 75 | 17 | 68 | 67 | 65 | | |
| Mannheim..... | 49 34N/8 28E | 359 | 2 | 8 | 11 | 87 | 85 | 82 | 18 | 71 | 69 | 68 | | |
| Munich..... | 48 09N/11 34E | 1729 | -1 | 5 | 9 | 86 | 83 | 80 | 18 | 68 | 66 | 64 | | |
| GHANA | | | | | | | | | | | | | | |
| Accra..... | 5 33N/0 12W | 88 | 65 | 68 | 69 | 91 | 90 | 89 | 13 | 80 | 79 | 79 | | |
| GIBRALTAR | | | | | | | | | | | | | | |
| Gibraltar..... | 36 09N/5 22W | 11 | 38 | 42 | 45 | 92 | 89 | 86 | 14 | 76 | 75 | 74 | | |
| GREECE | | | | | | | | | | | | | | |
| Athens..... | 37 58N/23 43E | 351 | 29 | 33 | 36 | 96 | 93 | 91 | 18 | 72 | 71 | 71 | | |
| Thessaloniki..... | 40 37N/22 57E | 78 | 23 | 28 | 32 | 95 | 93 | 91 | 20 | 77 | 76 | 75 | | |
| GREENLAND | | | | | | | | | | | | | | |
| Narsarsuaq..... | 61 11N/45 25W | 85 | -23 | -12 | -8 | 66 | 63 | 61 | 20 | 56 | 54 | 52 | | |
| GUATEMALA | | | | | | | | | | | | | | |
| Guatemala City..... | 14 37N/90 31W | 4855 | 45 | 48 | 51 | 83 | 82 | 81 | 24 | 69 | 68 | 67 | | |
| GUYANA | | | | | | | | | | | | | | |
| Georgetown..... | 6 50N/58 12W | 6 | 70 | 72 | 73 | 89 | 88 | 87 | 11 | 80 | 79 | 79 | | |
| HAITI | | | | | | | | | | | | | | |
| Port au Prince..... | 18 33N/72 20W | 121 | 63 | 65 | 67 | 97 | 95 | 93 | 20 | 82 | 81 | 80 | | |
| HONDURAS | | | | | | | | | | | | | | |
| Tegucigalpa..... | 14 06N/87 13W | 3094 | 44 | 47 | 50 | 89 | 87 | 85 | 28 | 73 | 72 | 71 | | |
| HONG KONG | | | | | | | | | | | | | | |
| Hong Kong..... | 22 18N/114 10E | 109 | 43 | 48 | 50 | 92 | 91 | 90 | 10 | 81 | 80 | 80 | | |
| HUNGARY | | | | | | | | | | | | | | |
| Budapest..... | 47 31N/19 02E | 394 | 8 | 10 | 14 | 90 | 86 | 84 | 21 | 72 | 71 | 70 | | |
| ICELAND | | | | | | | | | | | | | | |
| Reykjavik..... | 64 08N/21 56E | 59 | 8 | 14 | 17 | 59 | 58 | 56 | 16 | 54 | 53 | 53 | | |
| INDIA | | | | | | | | | | | | | | |
| Ahmenabad..... | 23 02N/72 35E | 163 | 49 | 53 | 56 | 109 | 107 | 105 | 28 | 80 | 79 | 78 | | |
| Bangalore..... | 12 57N/77 37E | 3021 | 53 | 56 | 58 | 96 | 94 | 93 | 26 | 75 | 74 | 74 | | |
| Bombay..... | 18 54N/72 49E | 37 | 62 | 65 | 67 | 96 | 94 | 92 | 13 | 82 | 81 | 81 | | |
| Calcutta..... | 22 32N/88 20E | 21 | 49 | 52 | 54 | 98 | 97 | 96 | 22 | 83 | 82 | 82 | | |
| Madras..... | 13 04N/80 15E | 51 | 61 | 64 | 66 | 104 | 102 | 101 | 19 | 84 | 83 | 83 | | |
| Nagpur..... | 21 09N/79 07E | 1017 | 45 | 51 | 54 | 110 | 108 | 107 | 30 | 79 | 79 | 78 | | |
| New Delhi..... | 28 35N/77 12E | 703 | 35 | 39 | 41 | 110 | 107 | 105 | 26 | 83 | 82 | 82 | | |
| INDONESIA | | | | | | | | | | | | | | |
| Djakarta..... | 6 11S/106 50E | 26 | 69 | 71 | 72 | 90 | 89 | 88 | 14 | 80 | 79 | 78 | | |
| Kupang..... | 10 10S/123 34E | 148 | 63 | 66 | 68 | 94 | 93 | 92 | 20 | 81 | 80 | 80 | | |
| Makassar..... | 5 08S/119 28E | 61 | 64 | 66 | 68 | 90 | 89 | 88 | 17 | 80 | 80 | 79 | | |
| Medan..... | 3 35N/98 41E | 77 | 66 | 69 | 71 | 92 | 91 | 90 | 17 | 81 | 80 | 79 | | |
| Palembang..... | 3 00S/104 46E | 20 | 67 | 70 | 71 | 92 | 91 | 90 | 17 | 80 | 79 | 79 | | |
| Surabaya..... | 7 13S/112 43E | 10 | 64 | 66 | 68 | 91 | 90 | 89 | 18 | 80 | 79 | 79 | | |

Climatic Conditions for Other Foreign Countries (Continued)

| Col. 1 Country and Station | Col. 2 Latitude and Longitude | Col. 3 Elevation, Ft | Winter | | | Summer | | | | | | | |
|-------------------------------|----------------------------------|-------------------------|--------------------------|-----|------|---------------------------|-----|-----|--------------------------------------|---------------------------|-----|----|--|
| | | | Col. 4 | | | Col. 5 Design Dry-Bulb | | | Col. 6 Out-door Daily Range F deg | Col. 7 Design Wet-Bulb | | | |
| | | | Mean of Annual Ex-tremes | 99% | 97½% | 1% | 2½% | 5% | | 1% | 2½% | 5% | |
| | | | | | | | | | | | | | |
| IRAN | | | | | | | | | | | | | |
| Abadan..... | 30 21N/48 16E | 7 | 32 | 39 | 41 | 116 | 113 | 110 | 32 | 82 | 81 | 81 | |
| Meshed..... | 36 17N/59 36E | 3104 | 3 | 10 | 14 | 99 | 96 | 93 | 29 | 68 | 67 | 66 | |
| Tehran..... | 35 41N/51 25E | 4002 | 15 | 20 | 24 | 102 | 100 | 98 | 27 | 75 | 74 | 73 | |
| IRAQ | | | | | | | | | | | | | |
| Baghdad..... | 33 20N/44 24E | 111 | 27 | 32 | 35 | 113 | 111 | 108 | 34 | 73 | 72 | 72 | |
| Mosul..... | 36 19N/43 09E | 730 | 23 | 29 | 32 | 114 | 112 | 110 | 40 | 73 | 72 | 72 | |
| IRELAND | | | | | | | | | | | | | |
| Dublin..... | 53 22N/6 21W | 155 | 19 | 24 | 27 | 74 | 72 | 70 | 16 | 65 | 64 | 62 | |
| Shannon..... | 52 41N/8 55W | 8 | 19 | 25 | 28 | 76 | 73 | 71 | 14 | 65 | 64 | 63 | |
| ISRAEL | | | | | | | | | | | | | |
| Jerusalem..... | 31 47N/35 13E | 2485 | 31 | 36 | 38 | 95 | 94 | 92 | 24 | 70 | 69 | 69 | |
| Tel Aviv..... | 32 06N/34 47E | 36 | 33 | 39 | 41 | 96 | 93 | 91 | 16 | 74 | 73 | 72 | |
| ITALY | | | | | | | | | | | | | |
| Milan..... | 45 27N/09 17E | 341 | 12 | 18 | 22 | 89 | 87 | 84 | 20 | 76 | 75 | 74 | |
| Naples..... | 40 53N/14 18E | 220 | 28 | 34 | 36 | 91 | 88 | 86 | 19 | 74 | 73 | 72 | |
| Rome..... | 41 48N/12 36E | 377 | 25 | 30 | 33 | 94 | 92 | 89 | 24 | 74 | 73 | 72 | |
| IVORY COAST | | | | | | | | | | | | | |
| Abidjan..... | 5 19N/4 01W | 65 | 64 | 67 | 69 | 91 | 90 | 88 | 15 | 83 | 82 | 81 | |
| JAPAN | | | | | | | | | | | | | |
| Fukuoka..... | 33 35N/130 27E | 22 | 26 | 29 | 31 | 92 | 90 | 89 | 20 | 82 | 80 | 79 | |
| Sapporo..... | 43 04N/141 21E | 56 | - 7 | 1 | 5 | 86 | 83 | 80 | 20 | 76 | 74 | 72 | |
| Tokyo..... | 35 41N/139 46E | 19 | 21 | 26 | 28 | 91 | 89 | 87 | 14 | 81 | 80 | 79 | |
| JORDAN | | | | | | | | | | | | | |
| Amman..... | 31 57N/35 57E | 2548 | 29 | 33 | 36 | 97 | 94 | 92 | 25 | 70 | 69 | 68 | |
| KENYA | | | | | | | | | | | | | |
| Nairobi..... | 1 16S/36 48E | 5971 | 45 | 48 | 50 | 81 | 80 | 78 | 24 | 66 | 65 | 65 | |
| KOREA | | | | | | | | | | | | | |
| Pyongyang..... | 39 02N/125 41E | 186 | -10 | - 2 | 3 | 89 | 87 | 85 | 21 | 77 | 76 | 76 | |
| Seoul..... | 37 34N/126 58E | 285 | - 1 | 7 | 9 | 91 | 89 | 87 | 16 | 81 | 79 | 78 | |
| LEBANON | | | | | | | | | | | | | |
| Beirut..... | 33 54N/35 28E | 111 | 40 | 42 | 45 | 93 | 91 | 90 | 15 | 78 | 77 | 76 | |
| LIBERIA | | | | | | | | | | | | | |
| Monrovia..... | 6 18N/10 48W | 75 | 64 | 68 | 69 | 90 | 89 | 88 | 19 | 82 | 82 | 81 | |
| LIBYA | | | | | | | | | | | | | |
| Bengasi..... | 32 06N/20 04E | 82 | 41 | 46 | 48 | 97 | 94 | 91 | 13 | 77 | 76 | 75 | |
| MADAGASCAR | | | | | | | | | | | | | |
| Tananarive..... | 18 55S/47 33E | 4531 | 39 | 43 | 46 | 86 | 84 | 83 | 23 | 73 | 72 | 71 | |
| MALAYSIA | | | | | | | | | | | | | |
| Kuala Lumpur..... | 3 07N/101 42E | 127 | 67 | 70 | 71 | 94 | 93 | 92 | 20 | 82 | 82 | 81 | |
| Penang..... | 5 25N/100 19E | 17 | 69 | 72 | 73 | 93 | 93 | 92 | 18 | 82 | 81 | 80 | |
| Singapore..... | 1 18N/103 50E | 33 | 69 | 71 | 72 | 92 | 91 | 90 | 14 | 82 | 81 | 80 | |
| MARTINIQUE | | | | | | | | | | | | | |
| Fort de France..... | 14 37N/61 05W | 13 | 62 | 64 | 66 | 90 | 89 | 88 | 14 | 81 | 81 | 80 | |
| MEXICO | | | | | | | | | | | | | |
| Guadalajara..... | 20 41N/103 20W | 5105 | 35 | 39 | 42 | 93 | 91 | 89 | 29 | 68 | 67 | 66 | |
| Mérida..... | 20 58N/89 38W | 72 | 56 | 59 | 61 | 97 | 95 | 94 | 21 | 80 | 79 | 77 | |
| Mexico City..... | 19 24N/99 12W | 7575 | 33 | 37 | 39 | 83 | 81 | 79 | 25 | 61 | 60 | 59 | |
| Monterrey..... | 25 40N/100 18W | 1732 | 31 | 38 | 41 | 98 | 95 | 93 | 20 | 79 | 78 | 77 | |
| Vera Cruz..... | 19 12N/96 08W | 184 | 55 | 60 | 62 | 91 | 89 | 88 | 12 | 83 | 83 | 82 | |
| MOROCCO | | | | | | | | | | | | | |
| Casablanca..... | 33 35N/7 39W | 164 | 36 | 40 | 42 | 94 | 90 | 86 | 50 | 73 | 72 | 70 | |
| NEPAL | | | | | | | | | | | | | |
| Katmandu..... | 27 42N/85 12E | 4388 | 30 | 33 | 35 | 89 | 87 | 86 | 25 | 78 | 77 | 76 | |
| NETHERLANDS | | | | | | | | | | | | | |
| Amsterdam..... | 52 23N/4 55E | 5 | 17 | 20 | 23 | 79 | 76 | 73 | 10 | 65 | 64 | 63 | |
| NEW GUINEA | | | | | | | | | | | | | |
| Manokwari..... | 0 52S/134 05E | 62 | 70 | 71 | 72 | 89 | 88 | 87 | 12 | 82 | 81 | 81 | |
| Point Moresby..... | 9 29S/147 09E | 126 | 62 | 67 | 69 | 92 | 91 | 90 | 14 | 80 | 80 | 79 | |
| NEW ZEALAND | | | | | | | | | | | | | |
| Auckland..... | 36 51S/174 46E | 140 | 37 | 40 | 42 | 78 | 77 | 76 | 14 | 67 | 66 | 65 | |
| Christ Church..... | 43 32S/172 37E | 32 | 25 | 28 | 31 | 82 | 79 | 76 | 17 | 68 | 67 | 66 | |
| Wellington..... | 41 17S/174 46E | 394 | 32 | 35 | 37 | 76 | 74 | 72 | 14 | 66 | 65 | 64 | |
| NICARAGUA | | | | | | | | | | | | | |
| Managua..... | 12 10N/86 15W | 135 | 62 | 65 | 67 | 94 | 93 | 92 | 21 | 81 | 80 | 79 | |
| NIGERIA | | | | | | | | | | | | | |
| Lagos..... | 6 27N/3 24E | 10 | 67 | 70 | 71 | 92 | 91 | 90 | 12 | 82 | 82 | 81 | |
| NORWAY | | | | | | | | | | | | | |
| Bergen..... | 60 24N/5 19E | 141 | 14 | 17 | 20 | 75 | 74 | 73 | 21 | 67 | 66 | 65 | |
| Oslo..... | 59 56N/10 44E | 308 | - 2 | 0 | 4 | 79 | 77 | 74 | 17 | 67 | 66 | 64 | |

Climatic Conditions for Other Foreign Countries (Continued)

| Col. 1 Country and Station | Col. 2 Latitude and Longitude | Col. 3 Elevation, Ft | Winter | | | Summer | | | | | | |
|-------------------------------|----------------------------------|-------------------------|-------------------------|-----|------|---------------------------|-----|-----|--------------------------------------|---------------------------|-----|----|
| | | | Col. 4 | | | Col. 5 Design Dry-Bulb | | | Col. 6 Out-door Daily Range F deg | Col. 7 Design Wet-Bulb | | |
| | | | Mean of Annual Extremes | 99% | 97½% | 1% | 2½% | 5% | | 1% | 2½% | 5% |
| | | | | | | | | | | | | |
| PAKISTAN | | | | | | | | | | | | |
| Chittagong..... | 22 21N/91 50E | 87 | 48 | 52 | 54 | 93 | 91 | 89 | 20 | 82 | 81 | 81 |
| Karachi..... | 24 48N/66 59E | 13 | 45 | 49 | 51 | 100 | 98 | 95 | 14 | 82 | 82 | 81 |
| Lahore..... | 31 35N/74 20E | 702 | 32 | 35 | 37 | 109 | 107 | 105 | 27 | 83 | 82 | 81 |
| Peshwar..... | 34 01N/71 35E | 1164 | 31 | 35 | 37 | 109 | 106 | 103 | 29 | 81 | 80 | 79 |
| PANAMA AND CANAL ZONE | | | | | | | | | | | | |
| Panama City..... | 8 58N/79 33W | 21 | 69 | 72 | 73 | 93 | 92 | 91 | 18 | 81 | 81 | 80 |
| PARAGUAY | | | | | | | | | | | | |
| Asunción..... | 25 17S/57 30W | 456 | 35 | 43 | 46 | 100 | 98 | 96 | 24 | 81 | 81 | 80 |
| PERU | | | | | | | | | | | | |
| Lima..... | 12 05S/77 03W | 394 | 51 | 53 | 55 | 86 | 85 | 84 | 17 | 76 | 75 | 74 |
| PHILIPPINES | | | | | | | | | | | | |
| Manila..... | 14 35N/120 59E | 47 | 69 | 73 | 74 | 94 | 92 | 91 | 20 | 82 | 81 | 81 |
| POLAND | | | | | | | | | | | | |
| Kraków..... | 50 04N/19 57E | 723 | - 2 | 2 | 6 | 84 | 81 | 78 | 19 | 68 | 67 | 66 |
| Warsaw..... | 52 13N/21 02E | 394 | - 3 | 3 | 8 | 84 | 81 | 78 | 19 | 71 | 70 | 68 |
| PORTUGAL | | | | | | | | | | | | |
| Lisbon..... | 38 43N/9 08W | 313 | 32 | 37 | 39 | 89 | 86 | 83 | 16 | 69 | 68 | 67 |
| PUERTO RICO | | | | | | | | | | | | |
| San Juan..... | 18 29N/66 07W | 82 | 65 | 67 | 68 | 89 | 88 | 87 | 11 | 81 | 80 | 79 |
| RUMANIA | | | | | | | | | | | | |
| Bucharest..... | 44 25N/26 06E | 269 | - 2 | 3 | 8 | 93 | 91 | 89 | 26 | 72 | 71 | 70 |
| SAUDI ARABIA | | | | | | | | | | | | |
| Dhahran..... | 26 17N/50 09E | 80 | 39 | 45 | 48 | 111 | 110 | 108 | 32 | 86 | 85 | 84 |
| Jedda..... | 21 28N/39 10E | 20 | 52 | 57 | 60 | 106 | 103 | 100 | 22 | 85 | 84 | 83 |
| Riyadh..... | 24 39N/46 42E | 1938 | 29 | 37 | 40 | 110 | 108 | 106 | 32 | 78 | 77 | 76 |
| SENEGAL | | | | | | | | | | | | |
| Dakar..... | 14 42N/17 29W | 131 | 58 | 61 | 62 | 95 | 93 | 91 | 13 | 81 | 80 | 80 |
| SOMALIA | | | | | | | | | | | | |
| Mogadiscio..... | 2 02N/49 19E | 39 | 67 | 69 | 70 | 91 | 90 | 89 | 12 | 82 | 82 | 81 |
| SOUTH AFRICA | | | | | | | | | | | | |
| Capetown..... | 33 56S/18 29E | 55 | 36 | 40 | 42 | 93 | 90 | 86 | 20 | 72 | 71 | 70 |
| Johannesburg..... | 26 11S/78 03E | 5463 | 26 | 31 | 34 | 85 | 83 | 81 | 24 | 70 | 69 | 69 |
| Pretoria..... | 25 45S/28 14E | 4491 | 27 | 32 | 35 | 85 | 87 | 85 | 23 | 70 | 69 | 68 |
| SOVIET UNION | | | | | | | | | | | | |
| Alma Ata..... | 43 14N/76 53E | 2543 | -18 | -10 | - 6 | 88 | 86 | 83 | 21 | 69 | 68 | 67 |
| Archangel..... | 64 33N/40 32E | 22 | -29 | -23 | -18 | 75 | 71 | 68 | 13 | 60 | 58 | 57 |
| Kaliningrad..... | 54 43N/20 30E | 23 | - 3 | + 1 | 6 | 83 | 80 | 77 | 17 | 67 | 66 | 65 |
| Krasnoyarsk..... | 56 01N/92 57E | 498 | -41 | -32 | -27 | 84 | 80 | 76 | 12 | 64 | 62 | 60 |
| Kiev..... | 50 27N/30 30E | 600 | -12 | - 5 | + 1 | 87 | 84 | 81 | 22 | 69 | 68 | 67 |
| Kharkov..... | 50 00N/36 14E | 472 | -19 | -10 | - 3 | 87 | 84 | 82 | 23 | 69 | 68 | 67 |
| Kuibyshev..... | 53 11N/50 06E | 190 | -23 | -19 | -13 | 89 | 85 | 81 | 20 | 69 | 67 | 66 |
| Leningrad..... | 59 56N/30 16E | 16 | -14 | - 9 | - 5 | 78 | 75 | 72 | 15 | 65 | 64 | 63 |
| Minsk..... | 53 54N/27 33E | 738 | -19 | -11 | - 4 | 80 | 77 | 74 | 16 | 67 | 66 | 65 |
| Moscow..... | 55 46N/37 40E | 505 | -19 | -11 | - 6 | 84 | 81 | 78 | 21 | 69 | 67 | 65 |
| Odessa..... | 46 29N/30 44E | 214 | - 1 | 4 | 8 | 87 | 84 | 82 | 14 | 70 | 69 | 68 |
| Petropavlovsk..... | 52 53N/158 42E | 286 | - 9 | - 3 | 0 | 70 | 68 | 65 | 13 | 58 | 57 | 56 |
| Rostov on Don..... | 47 13N/39 43E | 159 | - 9 | - 2 | 4 | 90 | 87 | 84 | 20 | 70 | 69 | 68 |
| Sverdlovsk..... | 56 49N/60 38E | 894 | -34 | -25 | -20 | 80 | 76 | 72 | 16 | 63 | 62 | 60 |
| Tashkent..... | 41 20N/69 18E | 1569 | - 4 | 3 | 8 | 95 | 93 | 90 | 29 | 71 | 70 | 69 |
| Tbilisi..... | 41 43N/44 48E | 1325 | 12 | 18 | 22 | 87 | 85 | 83 | 18 | 68 | 67 | 66 |
| Vladivostok..... | 43 07N/131 55E | 94 | -15 | -10 | - 7 | 80 | 77 | 74 | 11 | 70 | 69 | 68 |
| Volgograd..... | 48 42N/44 31E | 136 | -21 | -13 | - 7 | 93 | 89 | 86 | 19 | 71 | 70 | 69 |
| SPAIN | | | | | | | | | | | | |
| Barcelona..... | 41 24N/2 09E | 312 | 31 | 33 | 36 | 88 | 86 | 84 | 13 | 75 | 74 | 73 |
| Madrid..... | 40 25N/3 41W | 2188 | 22 | 25 | 28 | 93 | 91 | 89 | 25 | 71 | 69 | 67 |
| Valencia..... | 39 28N/0 23W | 79 | 31 | 33 | 37 | 92 | 90 | 88 | 14 | 75 | 74 | 73 |
| SUDAN | | | | | | | | | | | | |
| Khartoum..... | 15 37N/32 33E | 1279 | 47 | 53 | 56 | 109 | 107 | 104 | 30 | 77 | 76 | 75 |
| SURINAM | | | | | | | | | | | | |
| Paramaribo..... | 5 49N/55 09W | 12 | 66 | 68 | 70 | 93 | 92 | 90 | 18 | 82 | 82 | 81 |
| SWEDEN | | | | | | | | | | | | |
| Stockholm..... | 59 21N/18 04E | 146 | 3 | 5 | 8 | 78 | 74 | 72 | 15 | 64 | 62 | 60 |
| SWITZERLAND | | | | | | | | | | | | |
| Zurich..... | 47 23N/8 33E | 1617 | 4 | 9 | 14 | 84 | 81 | 78 | 21 | 68 | 67 | 66 |
| SYRIA | | | | | | | | | | | | |
| Damascus..... | 33 30N/36 20E | 2362 | 25 | 29 | 32 | 102 | 100 | 98 | 35 | 72 | 71 | 70 |
| TAIWAN | | | | | | | | | | | | |
| Tainan..... | 22 57N/120 12E | 70 | 40 | 46 | 49 | 92 | 91 | 90 | 14 | 84 | 83 | 82 |
| Taipei..... | 25 02N/121 31E | 30 | 41 | 44 | 47 | 94 | 92 | 90 | 16 | 83 | 82 | 81 |

Table C2
Earth Temperature Tables
for
Underground Heat Distribution System Design

The following Tables TG-1 through TG-11 were developed by applying monthly average temperatures prepared by the U. S. Weather Bureau for many localities in the United States to a technique described in the 1965 ASHRAE technical paper entitled "Earth Temperature and Thermal Diffusivity at Selected Stations in the United States" by T. Kusuda and P. R. Achenbach. These temperature data are, however, for the undisturbed earth. The earth temperature immediately under the building may be estimated by taking an arithmetic average of the building temperature and the design earth temperature found in the appropriate table. For example, the floor on grade in the Washington, D. C. area may be treated as a slab of 12" thickness with ground temperature of 70.5 °F if the room temperature is 75 °F and the summer design TG is determined from the data of Upper Marlboro, Maryland for ALPHA = 0.025 which is 66 °F.



Table TG-1
 DRY SOIL

AVERAGE EARTH TEMPERATURE IN DEG. F,

T_g

THERMAL DIFFUSIVITY IN FT**2/HR

ALPHA= .010

| STATION | STATES | WINTER | SPRING | SUMMER | FALL | YEAR |
|----------------------|--------|--------|--------|--------|------|------|
| AUBURN, ALABAMA | | 60. | 61. | 71. | 70. | 65. |
| DECATUR, ALABAMA | | 52. | 54. | 65. | 65. | 59. |
| PALMER AAs, ALASKA | | 31. | 31. | 42. | 41. | 36. |
| TEMPE, ARIZONA | | 62. | 64. | 73. | 74. | 68. |
| TUCSON, ARIZONA | | 68. | 69. | 77. | 79. | 73. |
| BRAWLEY, CALIFORNIA | | 70. | 73. | 83. | 84. | 77. |
| DAVIS, CALIFORNIA | | 61. | 61. | 72. | 72. | 67. |
| FT. COLLINS, COLO. | | 44. | 45. | 58. | 56. | 51. |
| STORRS, CONN. | | 46. | 45. | 58. | 58. | 52. |
| GAINESVILLE, FLA. | | 65. | 70. | 77. | 77. | 73. |
| ATHENS, GEORGIA | | 59. | 61. | 72. | 72. | 66. |
| MOSCOW, IDAHO | | 43. | 42. | 52. | 52. | 47. |
| LEMONT, ILLINOIS | | 46. | 45. | 59. | 59. | 52. |
| URBANA, ILLINOIS | | 46. | 47. | 61. | 60. | 53. |
| WEST LAFAYETTE, IND | | 47. | 47. | 62. | 61. | 54. |
| AMES, IOWA | | 44. | 45. | 62. | 60. | 52. |
| BURLINGTON, IOWA | | 47. | 49. | 66. | 65. | 56. |
| CASTANA, IOWA | | 42. | 42. | 61. | 59. | 51. |
| COUNCIL BLUFFS, IOWA | | 47. | 47. | 62. | 62. | 55. |
| SARATOGA, IOWA | | 41. | 40. | 59. | 57. | 49. |
| SPENCER, IOWA | | 42. | 42. | 58. | 57. | 50. |
| GARDEN CITY, KANSAS | | 48. | 51. | 66. | 66. | 58. |
| MANHATTAN, KANSAS | | 48. | 50. | 64. | 64. | 56. |
| MOUND VALLEY, KANSAS | | 52. | 54. | 68. | 68. | 60. |
| LEXINGTON, KENTUCKY | | 51. | 52. | 65. | 64. | 58. |
| UPPER MARLBORO, MD. | | 48. | 49. | 63. | 63. | 56. |
| EAST LANSING, MICH. | | 45. | 43. | 57. | 57. | 50. |
| FAIRMONT, MINNESOTA | | 42. | 43. | 58. | 57. | 50. |
| FARIBAULT, MINNESOTA | | 40. | 40. | 55. | 53. | 47. |
| ST. PAUL, MINNESOTA | | 42. | 40. | 57. | 56. | 49. |
| WASECA, MINNESOTA | | 41. | 46. | 59. | 54. | 50. |
| STATE UNIV., MISS. | | 60. | 62. | 73. | 73. | 67. |
| FAUCETT, MISSOURI | | 47. | 47. | 61. | 61. | 54. |
| KANSAS CITY, MO. | | 48. | 49. | 62. | 61. | 55. |
| SIKESTON, MISSOURI | | 52. | 54. | 67. | 67. | 60. |
| SPICKARD, MISSOURI | | 50. | 49. | 60. | 62. | 55. |
| BOZEMAN, MONTANA | | 39. | 37. | 50. | 48. | 43. |
| HUNTLEY, MONTANA | | 44. | 44. | 58. | 57. | 50. |
| LINCOLN, NEBRASKA | | 45. | 45. | 60. | 60. | 53. |
| NEW BRUNSWICK, N.J. | | 48. | 48. | 60. | 60. | 54. |
| ITHACA, NEW YORK | | 44. | 43. | 54. | 54. | 49. |
| COLUMBUS, OHIO | | 47. | 47. | 59. | 60. | 53. |
| COSHOCTON, OHIO | | 46. | 46. | 58. | 58. | 52. |
| WOOSTER, OHIO | | 46. | 46. | 58. | 58. | 52. |
| BARNSDALL, OKLAHOMA | | 56. | 57. | 69. | 69. | 63. |
| LAKE HEFNER, OKLA. | | 56. | 57. | 70. | 71. | 64. |
| PANHUSKA, OKLAHOMA | | 54. | 55. | 68. | 68. | 61. |
| OTTAWA, ONTARIO | | 42. | 39. | 54. | 52. | 47. |
| CORVALLIS, OREGON | | 50. | 51. | 61. | 60. | 55. |
| HOOD RIVER, OREGON | | 46. | 48. | 57. | 57. | 52. |

AVERAGE EARTH TEMPERATURE IN DEG. F. TG

THERMAL DIFFUSIVITY IN FT**2/HR ALPHA= .010

| STATION | STATES | WINTER | SPRING | SUMMER | FALL | YEAR |
|----------------|-------------|--------|--------|--------|------|------|
| MEDFORD | OREGON | 51. | 52. | 61. | 61. | 56. |
| PENDLETON | OREGON | 46. | 49. | 61. | 60. | 54. |
| STATE COLLEGE | PA. | 46. | 45. | 59. | 58. | 52. |
| KINGSTON | R. I. | 45. | 43. | 55. | 56. | 50. |
| CALHOUN | S. CAROLINA | 56. | 58. | 70. | 69. | 63. |
| MADISON | S. DAKOTA | 40. | 40. | 54. | 54. | 47. |
| JACKSON | TENNESSEE | 53. | 55. | 66. | 64. | 59. |
| TEMPLE | TEXAS | 64. | 65. | 77. | 77. | 71. |
| SALT LAKE CITY | UTAH | 44. | 45. | 56. | 55. | 50. |
| BURLINGTON | VERMONT | 42. | 40. | 54. | 53. | 48. |
| PULLMAN | WASHINGTON | 43. | 46. | 55. | 52. | 50. |
| SEATTLE | WASHINGTON | 48. | 50. | 56. | 56. | 53. |
| AFTON | WYOMING | 43. | 43. | 53. | 53. | 48. |

Table TG-2
AVERAGE SOIL

| AVERAGE EARTH TEMPERATURE IN DEG. F, | | TG | | | | |
|--------------------------------------|------------|-------------|--------|--------|------|------|
| THERMAL DIFFUSIVITY IN FT**2/HR | | ALPHA= .025 | | | | |
| STATION | STATES | WINTER | SPRING | SUMMER | FALL | YEAR |
| AUBURN, | ALABAMA | 57. | 61. | 74. | 70. | 65. |
| DECATUR, | ALABAMA | 49. | 53. | 69. | 66. | 59. |
| PALMER ARES, | ALASKA | 29. | 30. | 45. | 41. | 36. |
| TEMPE, | ARIZONA | 58. | 63. | 77. | 74. | 68. |
| TUCSON, | ARIZONA | 65. | 69. | 80. | 80. | 73. |
| BRAWLEY, | CALIFORNIA | 66. | 73. | 87. | 85. | 77. |
| DAVIS, | CALIFORNIA | 57. | 60. | 76. | 73. | 67. |
| FT. COLLINS, | COLO.- | 40. | 44. | 62. | 57. | 51. |
| STORRS, | CONN. | 43. | 44. | 62. | 59. | 52. |
| GAINESVILLE, | FLA. | 61. | 71. | 79. | 78. | 73. |
| ATHENS, | GEORGIA | 55. | 60. | 75. | 73. | 66. |
| MOSCOW, | IDAHO | 40. | 42. | 55. | 53. | 47. |
| LEMONT, | ILLINOIS | 42. | 44. | 64. | 60. | 52. |
| URBANA, | ILLINOIS | 42. | 47. | 65. | 61. | 53. |
| WEST LAFAYETTE, | IND | 43. | 47. | 66. | 62. | 54. |
| AMES, | IOWA | 39. | 44. | 67. | 61. | 52. |
| BURLINGTON, | IOWA | 42. | 48. | 71. | 66. | 56. |
| CASTANA, | IOWA | 36. | 41. | 66. | 61. | 51. |
| COUNCIL BLUFFS, | IOWA | 42. | 47. | 67. | 63. | 55. |
| SARATOGA, | IOWA | 37. | 39. | 64. | 58. | 49. |
| SPENCER, | IOWA | 37. | 41. | 62. | 58. | 50. |
| GARDEN CITY, | KANSAS | 42. | 51. | 71. | 67. | 58. |
| MANHATTAN, | KANSAS | 44. | 49. | 68. | 65. | 56. |
| MOUND VALLEY, | KANSAS | 47. | 54. | 72. | 69. | 60. |
| LEXINGTON, | KENTUCKY | 47. | 51. | 69. | 65. | 58. |
| UPPER MARLBORO, | MD. | 44. | 49. | 66. | 64. | 56. |
| EAST LANSING, | MICH. | 41. | 41. | 61. | 58. | 50. |
| FAIRMONT, | MINNESOTA | 38. | 43. | 63. | 57. | 50. |
| FARIBAULT, | MINNESOTA | 36. | 38. | 59. | 54. | 47. |
| ST. PAUL, | MINNESOTA | 38. | 38. | 62. | 57. | 49. |
| WASECA, | MINNESOTA | 36. | 47. | 64. | 54. | 50. |
| STATE UNIV., | MISS. | 56. | 62. | 76. | 74. | 67. |
| FAUCETT, | MISSOURI | 43. | 45. | 65. | 61. | 54. |
| KANSAS CITY, | MO. | 44. | 48. | 65. | 62. | 55. |
| SIKESTON, | MISSOURI | 48. | 54. | 72. | 68. | 60. |
| SPICKARD, | MISSOURI | 47. | 48. | 63. | 64. | 55. |
| BOZEMAN, | MONTANA | 36. | 36. | 53. | 49. | 43. |
| HUNTLEY, | MONTANA | 40. | 43. | 63. | 57. | 50. |
| LINCOLN, | NEBRASKA | 40. | 44. | 65. | 61. | 53. |
| NEW BRUNSWICK, | N.J. | 44. | 47. | 63. | 61. | 54. |
| ITHACA, | NEW YORK | 41. | 41. | 58. | 54. | 49. |
| COLUMBUS, | OHIO | 43. | 46. | 63. | 61. | 53. |
| COSHOCOTON, | OHIO | 42. | 45. | 61. | 59. | 52. |
| WOOSTER, | OHIO | 42. | 45. | 62. | 59. | 52. |
| BARNSDALL, | OKLAHOMA | 53. | 56. | 73. | 70. | 63. |
| LAKE HEFNER, | OKLA. | 52. | 56. | 74. | 72. | 64. |
| PAWHUSKA, | OKLAHOMA | 50. | 54. | 72. | 68. | 61. |
| OTTAWA, | ONTARIO | 39. | 37. | 58. | 52. | 47. |
| CORVALLIS, | OREGON | 47. | 50. | 64. | 60. | 55. |
| HOOD RIVER, | OREGON | 43. | 48. | 59. | 57. | 52. |

AVERAGE EARTH TEMPERATURE IN DEG. F, T6

THERMAL DIFFUSIVITY IN FT**2/HR

ALPHA= .025

| STATION | STATES | WINTER | SPRING | SUMMER | FALL | YEAR |
|-----------------|-------------|--------|--------|--------|------|------|
| MEDFORD, | OREGON | 48. | 52. | 64. | 61. | 56. |
| PENDLETON, | OREGON | 41. | 49. | 65. | 61. | 54. |
| STATE COLLEGE, | PA. | 42. | 44. | 63. | 59. | 52. |
| KINGSTON, | R. I. | 41. | 41. | 58. | 57. | 50. |
| CALHOUN, | S. CAROLINA | 52. | 57. | 73. | 70. | 63. |
| MADISON, | S. DAKOTA | 36. | 38. | 59. | 55. | 47. |
| JACKSON, | TENNESSEE | 50. | 55. | 69. | 64. | 59. |
| TEMPLE, | TEXAS | 61. | 65. | 81. | 77. | 71. |
| SALT LAKE CITY, | UTAH | 40. | 45. | 60. | 56. | 50. |
| BURLINGTON, | VERMONT | 39. | 38. | 59. | 54. | 48. |
| PULLMAN, | WASHINGTON | 40. | 45. | 58. | 52. | 50. |
| SEATTLE, | WASHINGTON | 46. | 50. | 59. | 56. | 53. |
| AFTON, | WYOMING | 41. | 42. | 56. | 53. | 48. |

Table TG-3
WET SOIL

| AVERAGE EARTH TEMPERATURE IN DEG. F, | | TG | | | | |
|--------------------------------------|------------|-------------|--------|--------|------|------|
| THERMAL DIFFUSIVITY IN FT**2/HR | | ALPHA= .050 | | | | |
| STATION | STATES | WINTER | SPRING | SUMMER | FALL | YEAR |
| AUBURN, | ALABAMA | 54. | 61. | 76. | 70. | 65. |
| DECATUR, | ALABAMA | 46. | 53. | 71. | 65. | 59. |
| PALMER ARES, | ALASKA | 27. | 30. | 48. | 41. | 36. |
| TEMPE, | ARIZONA | 56. | 64. | 79. | 74. | 68. |
| TUCSON, | ARIZONA | 62. | 69. | 82. | 81. | 73. |
| BRAWLEY, | CALIFORNIA | 63. | 73. | 90. | 84. | 77. |
| DAVIS, | CALIFORNIA | 55. | 60. | 78. | 73. | 67. |
| FT. COLLINS, | COLO. | 37. | 45. | 65. | 56. | 51. |
| STORRS, | CONN. | 40. | 44. | 65. | 59. | 52. |
| GAINESVILLE, | FLA. | 58. | 72. | 81. | 79. | 73. |
| ATHENS, | GEORGIA | 52. | 61. | 78. | 73. | 66. |
| MOSCOW, | IDAHO | 38. | 42. | 57. | 53. | 47. |
| LEMONT, | ILLINOIS | 39. | 44. | 67. | 60. | 52. |
| URBANA, | ILLINOIS | 39. | 47. | 68. | 60. | 53. |
| WEST LAFAYETTE, | IND | 40. | 47. | 69. | 62. | 54. |
| AMES, | IOWA | 35. | 44. | 70. | 61. | 52. |
| BURLINGTON, | IOWA | 38. | 48. | 74. | 66. | 56. |
| CASTANA, | IOWA | 32. | 42. | 70. | 61. | 51. |
| COUNCIL BLUFFS, | IOWA | 39. | 47. | 70. | 63. | 55. |
| SARATOGA, | IOWA | 33. | 39. | 68. | 58. | 49. |
| SPENCER, | IOWA | 33. | 42. | 66. | 58. | 50. |
| GARDEN CITY, | KANSAS | 38. | 52. | 74. | 67. | 58. |
| MANHATTAN, | KANSAS | 40. | 49. | 72. | 65. | 56. |
| MOUND VALLEY, | KANSAS | 44. | 55. | 75. | 69. | 60. |
| LEXINGTON, | KENTUCKY | 44. | 51. | 72. | 65. | 58. |
| UPPER MARLBORO, | MD. | 41. | 49. | 69. | 64. | 56. |
| EAST LANSING, | MICH. | 39. | 41. | 64. | 57. | 50. |
| FAIRMONT, | MINNESOTA | 35. | 43. | 67. | 57. | 50. |
| FARIBAULT, | MINNESOTA | 34. | 38. | 62. | 54. | 47. |
| ST. PAUL, | MINNESOTA | 35. | 38. | 65. | 57. | 49. |
| WASECA, | MINNESOTA | 31. | 49. | 67. | 53. | 50. |
| STATE UNIV., | MISS. | 53. | 62. | 78. | 74. | 67. |
| FAUCETT, | MISSOURI | 41. | 45. | 68. | 61. | 54. |
| KANSAS CITY, | MO. | 41. | 48. | 68. | 61. | 55. |
| SIKESTON, | MISSOURI | 45. | 54. | 75. | 68. | 60. |
| SPICKARD, | MISSOURI | 44. | 48. | 65. | 64. | 55. |
| BOZEMAN, | MONTANA | 34. | 35. | 57. | 48. | 43. |
| HUNTLEY, | MONTANA | 37. | 43. | 66. | 57. | 50. |
| LINCOLN, | NEBRASKA | 36. | 44. | 68. | 62. | 53. |
| NEW BRUNSWICK, | N.J. | 41. | 47. | 66. | 62. | 54. |
| ITHACA, | NEW YORK | 39. | 41. | 61. | 54. | 49. |
| COLUMBUS, | OHIO | 40. | 47. | 65. | 61. | 53. |
| CUSHOCTON, | OHIO | 40. | 45. | 64. | 60. | 52. |
| WOOSTER, | OHIO | 40. | 45. | 65. | 59. | 52. |
| BARNSDALL, | OKLAHOMA | 50. | 56. | 75. | 70. | 63. |
| LAKE HEFNER, | OKLA. | 49. | 57. | 77. | 73. | 64. |
| PAWBUSKA, | OKLAHOMA | 48. | 54. | 75. | 68. | 61. |
| OTTAWA, | ONTARIO | 37. | 37. | 61. | 51. | 47. |
| CORVALLIS, | OREGON | 45. | 51. | 67. | 60. | 55. |
| HOOD RIVER, | OREGON | 41. | 49. | 61. | 57. | 52. |

AVERAGE EARTH TEMPERATURE IN DEG. F, TG

THERMAL DIFFUSIVITY IN FT**2/HR

ALPHA= .050

| STATION | STATES | WINTER | SPRING | SUMMER | FALL | YEAR |
|-----------------|-------------|--------|--------|--------|------|------|
| MEUFORD, | OREGON | 46. | 52. | 66. | 61. | 56. |
| PENDLETON, | OREGON | 38. | 50. | 68. | 60. | 54. |
| STATE COLLEGE, | PA. | 40. | 44. | 66. | 59. | 52. |
| KINGSTON, | R. I. | 39. | 41. | 61. | 57. | 50. |
| CALHOUN, | S. CAROLINA | 49. | 58. | 76. | 69. | 63. |
| MADISON, | S. DAKOTA | 33. | 38. | 62. | 55. | 47. |
| JACKSON, | TENNESSEE | 48. | 55. | 72. | 64. | 59. |
| TEMPLE, | TEXAS | 58. | 65. | 84. | 77. | 71. |
| SALT LAKE CITY, | UTAH | 37. | 45. | 62. | 55. | 50. |
| BURLINGTON, | VERMONT | 37. | 38. | 62. | 54. | 48. |
| PULLMAN, | WASHINGTON | 37. | 45. | 60. | 50. | 50. |
| SEATTLE, | WASHINGTON | 44. | 50. | 60. | 56. | 53. |
| AFTON, | WYOMING | 39. | 42. | 59. | 53. | 48. |

Table C3

Thermophysical Properties of Wall/Roof/Floor

Reprinted by permission from 1972 Handbook of Fundamentals (American Society of Heating, Refrigerating and Air-Conditioning Engineers, 345 East 47th Street, New York), p. 431.



**Thermal Properties and Code Numbers of Layers Used in Calculations of
Coefficients for Wall and Roof Transfer Functions**

| Description | Code Number | Thickness and Thermal Properties ^a | | | | |
|---|-------------|---|--------------|----------|--------------|-------|
| | | L | K | D | SH | R |
| Outside surface resistance | A0 | | | | | 0.333 |
| 1" stucco (asbestos cement or wood siding plaster, etc.) | A1 | 0.0833 | 0.4 | 116 | 0.20 | |
| 4" face brick (dense concrete) | A2 | 0.333 | 0.77 | 125 | 0.22 | |
| Steel siding (aluminum or other light-weight cladding) | A3 | 0.005 | 26.0 | 480 | 0.10 | |
| Outside surface resistance, ½" slag, membrane and ½" felt | A4 | 0.0417 0.0313 | 0.83 0.11 | 55 70 | 0.40 0.40 | 0.333 |
| Outside surface resistance | A5 | | | | | 0.333 |
| Finish | A6 | 0.0417 | 0.24 | 78 | 0.26 | |
| Air space resistance | B1 | | | | | 0.91 |
| 1" insulation | B2 | 0.083 | 0.025 | 2.0 | 0.2 | |
| 2" insulation | B3 | 0.167 | 0.025 | 2.0 | 0.2 | |
| 3" insulation | B4 | 0.25 | 0.025 | 2.0 | 0.2 | |
| 1" insulation | B5 | 0.0833 | 0.025 | 5.7 | 0.2 | |
| 2" insulation | B6 | 0.167 | 0.025 | 5.7 | 0.2 | |
| 1" wood | B7 | 0.0833 | 0.07 | 37.0 | 0.6 | |
| 2.5" wood | B8 | 0.2083 | 0.07 | 37.0 | 0.6 | |
| 4" wood | B9 | 0.333 | 0.07 | 37.0 | 0.6 | |
| 2" wood | B10 | 0.167 | 0.07 | 37.0 | 0.6 | |
| 3" wood | B11 | 0.25 | 0.07 | 37.0 | 0.6 | |
| 3" insulation | B12 | 0.25 | 0.025 | 5.7 | 0.2 | |
| 4" clay tile | C1 | 0.333 | 0.33 | 70.0 | 0.2 | |
| 4" l.w. concrete block | C2 | 0.333 | 0.22 | 38.0 | 0.2 | |
| 4" h.w. concrete block | C3 | 0.333 | 0.47 | 61.0 | 0.2 | |
| 4" common brick | C4 | 0.333 | 0.42 | 120 | 0.2 | |
| 4" h.w. concrete | C5 | 0.333 | 1.0 | 140 | 0.2 | |
| 8" clay tile | C6 | 0.667 | 0.33 | 70 | 0.2 | |
| 8" l.w. concrete block | C7 | 0.667 | 0.33 | 38.0 | 0.2 | |
| 8" h.w. concrete block | C8 | 0.667 | 0.6 | 61.0 | 0.2 | |
| 8" common brick | C9 | 0.667 | 0.42 | 120 | 0.2 | |
| 8" h.w. concrete | C10 | 0.667 | 1.0 | 140 | 0.2 | |
| 12" h.w. concrete | C11 | 1.0 | 1.0 | 140 | 0.2 | |
| 2" h.w. concrete | C12 | 0.167 | 1.0 | 140 | 0.2 | |
| 6" h.w. concrete | C13 | 0.5 | 1.0 | 140 | 0.2 | |
| 4" l.w. concrete | C14 | 0.333 | 0.1 | 40 | 0.2 | |
| 6" l.w. concrete | C15 | 0.5 | 0.1 | 40 | 0.2 | |
| 8" l.w. concrete | C16 | 0.667 | 0.1 | 40 | 0.2 | |
| Inside surface resistance | E0 | | | | | 0.685 |
| ½" plaster; ½" gypsum or other similar finish- ing layer | E1 | 0.0625 | 0.42 | 100 | 0.2 | |
| ½" slag or stone | E2 | 0.0417 | 0.83 | 55 | 0.40 | |
| ½" felt & membrane | E3 | 0.0313 | 0.11 | 70 | 0.40 | |
| Ceiling air space | E4 | | | | | 1.0 |
| Acoustic Tile | E5 | 0.0625 | 0.035 | 30 | 0.20 | |

^a Units: L = feet. K = Btu per (hr) (sq ft) (F deg). D = lb per cu ft. SH = Btu per (lb) (F deg). R = (hr) (sq ft) (F deg) per Btu.

Table C4

Typical Watt/ft.² of floor area data

| | <u>Lighting</u> | <u>Equipment</u> |
|-------------------|-----------------|------------------|
| Apartment | 1.7 | 1.2 |
| Office | 5.0 | 1.0 |
| Department Stores | 4.0 | 0.0 |
| School | 5.0 | 0.0 |

Table C5

Shading Coefficients

Reprinted by permission from the 1972 Handbook of Fundamentals (American Society of Heating, Refrigerating and Air-Conditioning Engineers, 345 East 47th Street, New York), pp. 402-408.



Shading Coefficients for Single Glass and Insulating Glass^a

A. Single Glass

| Type of Glass | Nominal Thickness ^b | Solar Trans. ^b | Shading Coefficient | |
|--|--------------------------------|---------------------------|---------------------|-------------|
| | | | $h_0 = 4.0$ | $h_0 = 3.0$ |
| Regular Sheet Regular Plate/ Float | $\frac{3}{8}, \frac{1}{2}$ | 0.87 | 1.00 | 1.00 |
| | $\frac{1}{4}$ | 0.80 | 0.95 | 0.97 |
| | $\frac{3}{16}$ | 0.75 | 0.91 | 0.93 |
| | $\frac{1}{8}$ | 0.71 | 0.88 | 0.91 |
| Grey Sheet | $\frac{1}{8}$ | 0.59 | 0.78 | 0.80 |
| | $\frac{1}{16}$ | 0.74 | 0.90 | 0.92 |
| | $\frac{1}{32}$ | 0.45 | 0.66 | 0.70 |
| | $\frac{1}{64}$ | 0.71 | 0.88 | 0.90 |
| | $\frac{1}{8}$ | 0.67 | 0.86 | 0.88 |
| Heat-Absorbing Plate/Float ^d | $\frac{1}{16}$ | 0.52 | 0.72 | 0.75 |
| | $\frac{1}{8}$ | 0.47 | 0.70 | 0.74 |
| | $\frac{1}{16}$ | 0.33 | 0.56 | 0.61 |
| | $\frac{1}{8}$ | 0.24 | 0.50 | 0.57 |

B. Insulating Glass^a

| Type of Glass | Nominal Thickness ^a | Solar Trans. ^b | | Shading Coefficient | |
|---|--------------------------------|---------------------------|------------|---------------------|-------------|
| | | Outer Pane | Inner Pane | $h_0 = 4.0$ | $h_0 = 3.0$ |
| Regular Sheet Out, Regular Sheet In | $\frac{3}{8}, \frac{1}{2}$ | 0.87 | 0.87 | 0.90 | 0.90 |
| Regular Plate/Float Out, Regular Plate/Float In | | | | | |
| Heat-Abs Plate/Float Out, Regular Plate/Float In | $\frac{1}{4}$ | 0.80 | 0.80 | 0.83 | 0.83 |
| Heat-Abs Plate/Float Out, Regular Plate/Float In | $\frac{1}{4}$ | 0.46 | 0.80 | 0.56 | 0.58 |

^a Refers to factory-fabricated units with $\frac{1}{4}$, $\frac{1}{2}$, or $\frac{3}{8}$ in. air space or to prime windows plus storm windows.

^b Refer to manufacturer's literature for values.

^c Thickness of each pane of glass, not thickness of assembled unit.

^d Refers to grey, bronze, and green tinted heat-absorbing plate/float glass.

Shading Coefficients for Single Glass with Indoor Shading by Venetian Blinds and Roller Shades

| Type of Glass | Nominal Thickness ^a | Solar Trans. ^b | Type of Shading | | | | |
|---|---|--|------------------------------|------------------------------|--------------|-------|-------------|
| | | | Venetian Blinds | | Roller Shade | | |
| | | | Medium | Light | Opaque | | Translucent |
| | | | | | Dark | White | Light |
| Regular Sheet Regular Plate/Float Regular Pattern Heat-Absorbing Pattern Grey Sheet | $\frac{3}{32}$ to $\frac{1}{4}$ $\frac{1}{4}$ to $\frac{1}{2}$ $\frac{1}{8}$ to $\frac{3}{32}$ $\frac{1}{8}$ $\frac{3}{16}, \frac{7}{32}$ | 0.87-0.80 0.80-0.71 0.87-0.79 — 0.74, 0.71 | 0.64 | 0.55 | 0.59 | 0.25 | 0.39 |
| Heat-Absorbing Plate/Float ^d Heat-Absorbing Pattern Grey Sheet | $\frac{3}{16}, \frac{1}{4}$ $\frac{3}{16}, \frac{1}{4}$ $\frac{1}{8}, \frac{7}{32}$ | 0.46 — 0.59, 0.45 | 0.57 | 0.53 | 0.45 | 0.30 | 0.36 |
| Heat-Absorbing Plate/Float or Pattern Heat-Absorbing Plate/Float ^d | — $\frac{3}{8}$ | 0.44-0.30 0.34 | 0.54 | 0.52 | 0.40 | 0.28 | 0.32 |
| Heat-Absorbing Plate or Pattern | — | 0.29-0.15 0.24 | 0.42 | 0.40 | 0.36 | 0.28 | 0.31 |
| Reflective Coated Glass S.C. ^c = 0.30 0.40 0.50 0.60 | | | 0.25 0.33 0.42 0.50 | 0.23 0.29 0.38 0.44 | | | |

^a Refer to manufacturer's literature for values.
^b For vertical blinds with opaque white and beige louvers in the tightly closed position, SC is 0.25 and 0.29 when used with glass of 0.71 to 0.80 transmittance.
^c Shading Coefficient for glass with no shading device.
^d Refers to grey, bronze, and green tinted heat-absorbing plate/float glass.

Shading Coefficients for Insulating Glass^a with Indoor Shading by Venetian Blinds and Roller Shades

| Type of Glass | Nominal Thickness, each light | Solar Trans. ^b | | Type of Shading | | | | |
|--|--|---------------------------|--------------|------------------------------|----------------------|--------------|--------------|--------------|
| | | | | Venetian Blinds ^c | | Roller Shade | | |
| | | Outer Pane | Inner Pane | Medium | Light | Opaque | | Translucent |
| | | | | | | Dark | White | Light |
| Regular Sheet Out Regular Sheet In Regular Plate/Float Out Regular Plate/Float In | $\frac{3}{32}, \frac{1}{8}$ $\frac{1}{4}$ | 0.87 0.80 | 0.87 0.80 | 0.57 0.51 | 0.51 0.36 | 0.60 0.40 | 0.25 0.22 | 0.37 0.30 |
| Heat-Absorbing Plate/Float ^d Out Regular Plate/Float In | $\frac{1}{4}$ | 0.46 | 0.80 | 0.39 | 0.36 | 0.40 | 0.22 | 0.30 |
| Reflective Coated Glass SC ^c = 0.20 0.30 0.40 | | | | 0.19 0.27 0.34 | 0.18 0.26 0.33 | | | |

^a Refers to factory-fabricated units with $\frac{1}{8}$, $\frac{1}{4}$, or $\frac{1}{2}$ in. air space, or to prime windows plus storm windows.
^b Refer to manufacturer's literature for exact values.
^c For vertical blinds with opaque white or beige louvers, tightly closed, SC is approximately the same as for opaque white roller shades.
^d Refers to bronze or green tinted heat-absorbing plate/float glass.
^e Shading Coefficient for glass with no shading device.

Properties of Representative Indoor Shading

| Indoor Shade | Solar Properties (Normal Incidence) | | |
|---|--|----------|---------|
| | Trans. | Reflect. | Absorp. |
| Venetian Blinds* (Ratio of slat width to slat spacing 1.2, slat angle 45 deg) | | | |
| Light Colored Slat | 0.05 | 0.55 | 0.40 |
| Medium Colored Slat | 0.05 | 0.35 | 0.60 |
| Vertical Blinds | | | |
| White Louvers | 0.00 | 0.77 | 0.23 |
| Roller Shades | | | |
| Light Shades (Translucent) | 0.25 | 0.60 | 0.15 |
| White Shade (Opaque) | 0.00 | 0.80 | 0.20 |
| Dark Colored Shade (Opaque) | 0.00 | 0.12 | 0.88 |

* The values shown in this table and preceding tables are based on horizontal Venetian blinds. However, tests show these values may be used for vertical blinds with good accuracy.

Shading Coefficients for Double Glazing with Between-Glass Shading

| Type of Glass | Nominal Thickness, each pane | Solar Trans. ^a | | Description of Air Space | Type of Shading | | |
|--|---|---------------------------|--------------|---|-----------------|-----------|---------------------|
| | | Outer Pane | Inner Pane | | Venetian Blinds | | Louvered Sun Screen |
| | | | | | Light | Medium | |
| Regular Sheet Out Regular Sheet In Regular Plate Out Regular Plate In | $\frac{3}{8}, \frac{1}{8}$ $\frac{1}{4}$ | 0.87 0.80 | 0.87 0.80 | Shade in contact with glass or shade separated from glass by air space. Shade in contact with glass-voids filled with plastic. | 0.33 — | 0.36 — | 0.43 0.49 |
| Heat-Abs. Plate/Float ^b Out Regular Plate In | $\frac{1}{4}$ | 0.46 | 0.80 | Shade in contact with glass or shade separated from glass by air space. Shade in contact with glass-voids filled with plastic. | 0.28 — | 0.30 — | 0.37 0.41 |

^a Refer to manufacturer's literature for exact values.

^b Refers to grey, bronze, and green tinted heat-absorbing plate/float glass.

Shading Coefficients for Single and Insulating Glass with Draperies

| Glazing | Glass Trans. | Glass SC* | Shading Coefficient For Index Letters in Fig. 10** | | | | | | | | | | |
|--|--------------|-----------|--|------|------|------|------|------|------|------|------|------|--|
| | | | A | B | C | D | E | F | G | H | I | J | |
| Single Glass | | | | | | | | | | | | | |
| 1/2 in. Regular | 0.80 | 0.95 | 0.35 | 0.40 | 0.45 | 0.50 | 0.55 | 0.60 | 0.65 | 0.70 | 0.75 | 0.80 | |
| 3/4 in. Regular | 0.71 | 0.88 | 0.35 | 0.39 | 0.43 | 0.48 | 0.52 | 0.56 | 0.61 | 0.66 | 0.70 | 0.74 | |
| 1 in. Heat Abs. | 0.46 | 0.67 | 0.33 | 0.36 | 0.38 | 0.41 | 0.44 | 0.46 | 0.49 | 0.52 | 0.54 | 0.57 | |
| 1 1/4 in. Heat Abs. | 0.34 | 0.57 | 0.32 | 0.34 | 0.36 | 0.38 | 0.41 | 0.43 | 0.45 | 0.47 | 0.49 | 0.51 | |
| 1 3/4 in. Heat Abs. | 0.24 | 0.50 | 0.30 | 0.32 | 0.33 | 0.34 | 0.36 | 0.38 | 0.39 | 0.40 | 0.42 | 0.43 | |
| Reflective Coated (See Manufacturers' literature for exact values) | — | 0.60 | 0.33 | 0.36 | 0.38 | 0.41 | 0.43 | 0.46 | 0.49 | 0.51 | 0.54 | 0.57 | |
| | — | 0.50 | 0.31 | 0.33 | 0.34 | 0.36 | 0.38 | 0.39 | 0.41 | 0.42 | 0.44 | 0.46 | |
| | — | 0.40 | 0.26 | 0.27 | 0.28 | 0.29 | 0.30 | 0.32 | 0.33 | 0.34 | 0.35 | 0.36 | |
| | — | 0.30 | 0.20 | 0.21 | 0.21 | 0.22 | 0.23 | 0.23 | 0.23 | 0.24 | 0.24 | 0.25 | |
| Insulating Glass (1/2 in. Air Space) Regular Out and Regular In | 0.64 | 0.83 | 0.35 | 0.37 | 0.42 | 0.45 | 0.48 | 0.52 | 0.56 | 0.58 | 0.62 | 0.66 | |
| Heat Abs. Out and Regular In | 0.37 | 0.56 | 0.32 | 0.33 | 0.35 | 0.37 | 0.39 | 0.41 | 0.43 | 0.45 | 0.47 | 0.49 | |
| Reflective Coated (see Manufacturers' literature for exact values) | — | 0.40 | 0.28 | 0.28 | 0.29 | 0.31 | 0.32 | 0.34 | 0.36 | 0.37 | 0.37 | 0.38 | |
| | — | 0.30 | 0.24 | 0.24 | 0.25 | 0.25 | 0.26 | 0.26 | 0.27 | 0.27 | 0.28 | 0.29 | |
| | — | 0.20 | 0.15 | 0.15 | 0.16 | 0.16 | 0.17 | 0.17 | 0.18 | 0.18 | 0.19 | 0.19 | |

* For glass alone, with no drapery.

** Shading coefficient values for the SC lines in Fig. 10 for representative glazings. Substitute for the SC index letters in Fig. 10 the values on the line of the glazing selected.

Shading Coefficients for Louvered Sun Screens

| Profile Angle, deg | Group 1 | | Group 2 | |
|-----------------------|---------------|------|---------------|------|
| | Transmittance | SC | Transmittance | SC |
| 10 | 0.23 | 0.35 | 0.25 | 0.33 |
| 20 | 0.06 | 0.17 | 0.14 | 0.23 |
| 30 | 0.04 | 0.15 | 0.12 | 0.21 |
| 40 and above | 0.04 | 0.15 | 0.11 | 0.20 |

| Profile Angle, deg | Group 3 | | Group 4 | |
|-----------------------|---------------|------|---------------|------|
| | Transmittance | SC | Transmittance | SC |
| 10 | 0.40 | 0.51 | 0.48 | 0.59 |
| 20 | 0.32 | 0.42 | 0.39 | 0.50 |
| 30 | 0.21 | 0.31 | 0.28 | 0.38 |
| 40 and above | 0.07 | 0.18 | 0.20 | 0.30 |

Group 1. Black, width over spacing ratio 1.15/1, 23 louvers per inch.
 Group 2. Light color, high reflectance, otherwise same as Group 1.
 Group 3. Black or dark color, w/s ratio 0.85/1, 17 louvers per inch.
 Group 4. Light color or unpainted aluminum, high reflectance, otherwise same as Group 3.
 U-value = 0.85 Btuh/(sq ft)(F deg) for all groups when used with single glazing.

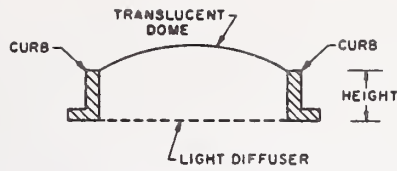

Fig. . . . Terminology for Domed Skylights

Table 23 . . . Shading Coefficients for Domed Skylights

| Dome | Light Diffuser (Translucent) | Curb (See Fig.) | | Shading Coefficient | U-Value |
|----------------------------|------------------------------|------------------|-----------------------|---------------------|---------|
| | | Height, in. | Width to Height Ratio | | |
| Clear $\tau=0.86$ | yes $\tau=0.58$ | 0 | ∞ | 0.61 | 0.46 |
| | | 9 | 5 | 0.58 | 0.43 |
| | | 18 | 2.5 | 0.50 | 0.40 |
| Clear $\tau=0.86$ | None | 0 | ∞ | 0.99 | 0.80 |
| | | 9 | 5 | 0.88 | 0.75 |
| | | 18 | 2.5 | 0.80 | 0.70 |
| Translucent $\tau=0.52$ | None | 0 | ∞ | 0.57 | 0.80 |
| | | 9 | 5 | 0.51 | 0.75 |
| | | 18 | 2.5 | 0.46 | 0.70 |
| Translucent $\tau=0.27$ | None | 0 | ∞ | 0.34 | 0.80 |
| | | 9 | 5 | 0.30 | 0.75 |
| | | 18 | 2.5 | 0.28 | 0.70 |

Shading Coefficients for Hollow Glass Block Wall Panels^a

| Type of Glass Block ^b | Description of Glass Block | Shading Coefficient ^c | |
|----------------------------------|--|----------------------------------|---|
| | | Panels ^d in the Sun | Panels ^e in the Shade (N, NW, W, SW) |
| Type I | Glass Colorless or Aqua Smooth Face A, D: Smooth B, C: Smooth or wide ribs, or flutes horizontal or vertical, or shallow configuration. E: None | 0.65 | 0.40 |
| Type IA | Same as Type I except A: Ceramic Enamel on exterior face. | 0.27 | 0.20 |
| Type II | Same as Type I except E: Glass fiber screen. | 0.44 | 0.34 |
| Type III | Glass Colorless or Aqua A, D: Narrow vertical ribs or flutes. B, C: Horizontal light-diffusing prisms, or horizontal light-directing prisms. E: Glass fiber screen. | 0.33 | 0.27 |
| Type IIIA | Same as Type III except E: Glass fiber screen with green ceramic spray coating, or glass fiber screen and gray glass, or glass fiber screen with light-selecting prisms. | 0.25 | 0.18 |

^a For glass block used in horizontal skylights see Tables 28 and 29, Chapter 26 of the 1963 ASHRAE GUIDE AND DATA BOOK.

^b All values are for 7½ × 7½ × 3½ in. block, set in light-colored mortar. For 11½ × 11½ × 3½ in. block increase coefficients by 15 percent, and for 5½ × 5½ × 3½ in. blocks reduce coefficients by 15 percent.

^c Shading coefficients are to be applied to Heat Gain Factors for one hour earlier than the time for which the load calculation is made to allow for heat storage in the panel.

^d Shading coefficients are for peak load condition, but provide a close approximation for other conditions. For more precise values for other conditions, see Reference 20.

^e For NE, E, and SE panels in the shade add 50 percent to the values listed for panels in the shade.

Table C6

Absorptivity of Materials to Solar Radiation

Reprinted by permission from Thermal Radiation Properties Survey (Honeywell Research Center, Minneapolis, Minnesota, 1966), pp. 245-248.

BUILDING MATERIALS, SOLAR ABSORPTIVITY

| Material | Solar Absorptivity |
|----------------------------------|--------------------|
| BRICKS | |
| Clay, cream, glazed | 0.36 |
| Clay, Fleton, dark portion | 0.63 |
| Clay, Felton, light portion | 0.40 |
| Lime clay, French | 0.46 |
| Gault, cream | 0.36 |
| Light buff | 0.516 |
| Light buff but darker than above | 0.60 |
| Mottled purple | 0.77 |
| Red | 0.699 |
| Red, common and tiles | 0.68 |
| Red, darker, glazed | 0.766 |
| Red, wire-cut | 0.52 |
| Stafford blue | 0.89 |
| Stock, light fawn | 0.57 |
| White glazed | 0.26 |
| White glazed (2 specimens) | 0.25-0.27 |
| TILES | |
| Clay, purple (dark) | 0.82 |
| Clay, dark purple, machine-made | 0.81 |
| Red | 0.67 |
| Red, hand-made | 0.60 |
| Red, light, Dutch | 0.43 |
| Red, light, machine-made | 0.66 |
| Red, light, machine-made | 0.62 |
| Concrete, uncolored | 0.65 |
| Concrete, black | 0.91 |
| Concrete, dark | 0.91 |
| Concrete, brown | 0.85 |
| Concrete, brown, very rough | 0.88 |

(Continued on next page)

BUILDING MATERIALS, SOLAR ABSORPTIVITY (Continued)

| Material | Solar Absorptivity |
|--|--------------------|
| ASPHALT | |
| New, 3 specimens | 0.91 |
| New, 3 specimens | 0.91 |
| New, another specimen | 0.93 |
| Pavement | 0.852 |
| Pavement, free from dust | 0.928 |
| Pavement, weathered, 3 specimens | 0.82 |
| | 0.83 |
| | 0.89 |
| ROOFING | |
| Bituminous felt, aluminized ¹ | 0.40 |
| Bituminous felt | 0.88 |
| Bituminous felt | 0.89 |
| Bitumin-covered, brown | 0.87 |
| Sheet, green | 0.86 |
| Sheet, black matte surface | 0.97 |
| Sheet, black matte surface | 0.97 |
| ASBESTOS CEMENT | |
| Aged | 0.75 |
| Aged 6 months | 0.61 |
| Aged 12 months | 0.71 |
| Aged 6 years, very dirty | 0.83 |
| Red | 0.69 |
| Red | 0.74 |
| Washed with soap and water | 0.40 |
| White | 0.61 |
| White (2 samples) | 0.49-0.42 |
| LIMESTONE | |
| Anston | 0.60 |
| Bath | 0.53 |
| Clipsham | 0.46 |
| Indiana | 0.571 |
| Ketton | 0.42 |
| Portland | 0.36 |
| Steetley | 0.33 |
| SAND-LIME | |
| Light-red | 0.55 |
| Red | 0.68 |
| White, fine sand | 0.41 |
| White, coarse sand | 0.50 |
| MARBLE | |
| White | 0.44 |
| Ground, unpolished | 0.465 |
| Cleavage | 0.592 |
| GRANITE | |
| Reddish | 0.55 |
| FELDSPAR | |
| $K_2O Al_2O_3 6SiO_2$ | 0.606 |
| MORTAR SCREENED | |
| | 0.73 |

(Continued on next page)

BUILDING MATERIALS, SOLAR ABSORPTIVITY (Continued)

| Material | Solar Absorptivity |
|--|--------------------|
| SANDSTONE | |
| Grey, Bristol pennant | 0.76 |
| Polmaise, light fawn | 0.54 |
| Stancliffe, light grey | 0.62 |
| Woolton, red | 0.73 |
| WHITEWASH | |
| On galvanized iron | 0.22 |
| On galvanized iron | 0.22 |
| On galvanized iron | 0.26 |
| On galvanized iron, a very thick layer | 0.20 |
| SLATE | |
| Blue grey | 0.87 |
| Blue, grey | 0.85 |
| Clay, dark | 0.933 |
| Greenish, grey, rough | 0.88 |
| Grey, dark | 0.90 |
| Grey, dark, fairly rough | 0.90 |
| Grey, dark, fairly rough | 0.90 |
| Grey, dark, smooth | 0.89 |
| Purple | 0.86 |
| Silver-grey, Norwegian | 0.79 |

BUILDING MATERIALS, SOLAR ABSORPTIVITY

| Building Materials | Solar Absorptivity |
|------------------------|--------------------|
| Thickly tinned surface | 0.05 |
| Wood, smoothly planed | 0.78 |
| Basalt | 0.72 |
| Red sandstone | 0.60 |
| Marble (white) | 0.58 |
| Granite | 0.45 |
| Dolomite lime | 0.41 |
| Clay shale | 0.69 |
| Paris plaster | 0.78 |
| White plastered wall | 0.92 |
| Gravel | 0.29 |
| Sand | 0.76 |
| Glass | 0.93 |
| Sawdust | 0.75 |
| Clay | 0.39 |
| Red brick wall | 0.93 |

CLOTH, SOLAR REFLECTIVITY

| Material | Solar Reflectivity |
|---|--------------------|
| QM1, cotton sheeting bleached, 4 oz per yd | 0.62-0.66 |
| QM2, cotton sateen prepared for dyeing, 9 oz per yd | 0.68-0.72 |
| QM4, cotton sateen undyed, 9 oz per yd | 0.69-0.72 |
| QM6, cotton sateen, medium gray, 9 oz per yd | 0.53 |
| QM7, cotton sateen dark gray, 9 oz per yd | 0.24 |
| 50 percent wool, 50 percent cotton knit, undyed, 10.5 oz per yd | 0.62 |
| Cotton knit, undyed, 3 oz per yd | 0.60 |

PARACHUTE CLOTH, SOLAR ABSORPTIVITY, REFLECTIVITY, AND TRANSMISSIVITY

| Material | Absorptivity | Reflectivity | Transmissivity |
|--|--------------|--------------|----------------|
| Dacron, 100 lb | 0.05 | 0.35 | 0.60 |
| Dacron, 300 lb | 0.11 | 0.54 | 0.35 |
| Dacron, 600 lb | 0.12 | 0.61 | 0.27 |
| Dacron, 800 lb | 0.19 | 0.62 | 0.19 |
| Nylon rip-stop (orange) 1.1 oz per sq yd, MIL-C-7020B Type I | 0.13 | 0.23 | 0.64 |
| Nylon rip-stop 1.1 oz per sq yd (white) MIL-C-7020 | 0.08 | 0.27 | 0.65 |
| Nylon rip-stop 1.6 oz per sq yd (white) MIL-C-7020B Type III | 0.06 | 0.22 | 0.72 |
| Nylon cloth 2.25 oz per sq yd, MIL-C-7350B Type I | 0.05 | 0.36 | 0.59 |
| Nylon cloth 4.30 oz per sq yd, MIL-C-8021 Type I | 0.08 | 0.44 | 0.48 |
| Nylon cloth 7.0 oz per sq yd, MIL-C-8021 Type II | 0.13 | 0.46 | 0.41 |
| Nylon cloth 14.0 oz per sq yd, MIL-C-8021 Type III | 0.11 | 0.62 | 0.27 |

NBSLD

SAMPLE INPUT/OUTPUT

L

2 CEILING TO COND. SPACE-3.16 W-NO SHADE-25(SOLARGRAY
 3 0,0,0,0,0,0,0,1,1,1,1,1,1,1,1,1,1,0,0,0,0,0,0,0
 4 0,0,0,0,0,0,0,1,1,1,1,1,1,1,1,1,1,0,0,0,0,0,0,0
 5 0,0,0,0,0,0,0,1,1,1,1,1,1,1,1,1,1,0,0,0,0,0,0,0
 6 0,0
 7 0,0
 8 0,0
 9 0,0
 10 0,0
 11 0,0
 12 80,80,80,80,80,80,80,80,75,75,75,75,75,75,75,75,75,80,80,80,80,80,80,80
 13 60,60,60,60,60,60,60,60,70,70,70,70,70,70,70,70,70,60,60,60,60,60,60,60
 14 60,80,20,50
 15 31,0,10
 16 7,21,201,97,20,67,20,60,50,0.1,87,42,6,13.5,60
 17 ROOM WITH GLASS AREA FACING SOUTH
 18 0,0,0
 19 4
 20 0.167,1.0,140.0,0.2,0.0
 21 0.334,0.025,5.7,0.2,0.0
 22 0.0313,0.11,70.0,0.4,0.0
 23 0.0417,0.83,55.0,0.4,0.0
 24 2-" HW CONCRETE
 25 4" INSULATION
 26 3/8" FELT & MEMBRANE
 27 1/2" SLAG
 28 4
 29 0.005,26.0,480.0,0.1,0.0
 30 0,0,0,0,.91
 31 0.167,0.0133,2.5,0.38,0.0
 32 0.005,26.0,480.0,0.1,0.0
 33 STEEL SIDING
 34 AIR SPACE
 35 INSULATION MODIFIED
 36 STEEL SIDING
 37 2
 38 0.5,1.0,140.0,0.2,0.0
 39 0.3637,0.025,5.7,0.2,0.0
 40 6" CONCRETE
 41 4.43" INSULATION
 42 3
 43 0.04166,0.42,100.0,0.2,0.0
 44 0,0,0,0,.91
 45 0.04166,0.42,100.0,0.2,0.0
 46 1/2" GYPSUM BOARD
 47 AIR SPACE
 48 1/2" GYPSUM BOARD
 49 2
 50 0.5,1.0,140.0,0.2,0.0
 51 0,0,0,0,1.
 52 6" CONCRETE
 53 CEILING AIR SPACE
 54 2

```

55 0,0,0,0,1.
56 0.5,1.0,140.0,0.2,0.0
57 CEILING AIR SPACE
58 6" CONCRETE
59 0
60 1.0,3.16,1.0,2.0,0.0,0.5,0.0,30.0,0.25,0.25,0.0,1.0
61 3,1,8,17
62 75,60,0,0,70,60
63 1,1
64 2,1,1,1
65 13.5,13.5,9.0
66 6,6,182.25,0,0,0,.85,0
67 0,0,0,0,0,0,0
68 0,0,0,0,0,0,0
69 2,2,91.12,0,0,0,.85,0
70 0,0,0,0,0,0,0
71 0,0,0,0,0,0,0
72 3,10,30.38,0,1.06,.67,0,0
73 0,0,0,0,0,0,0
74 0,0,0,0,0,0,0
75 6,4,121.5,90,0,0,0,0
76 0,0,0,0,0,0,0
77 0,0,0,0,0,0,0
78 6,4,121.5,180,0,0,0,0
79 0,0,0,0,0,0,0
80 0,0,0,0,0,0,0
81 6,4,121.5,-90,0,0,0,0
82 0,0,0,0,0,0,0
83 0,0,0,0,0,0,0
84 6,5,182.25,0,0,0,0,0
85 0,0,0,0,0,0,0
86 0,0,0,0,0,0,0
87 0,0,0,0,0,0
88 0,0,0,6,0
89 ROOM WITH GLASS AREA FACING WEST
90 90,1,1
91 ROOM WITH GLASS AREA FACING NORTH
92 90,1,1
93 ROOM WITH GLASS AREA FACING EAST
94 90,1,1

```

Q

CONGRATULATIONS!! NOW YOU ARE ON NBSLD

WE ASSUME YOU HAVE ALREADY PREPARED THE DATA
ON NBS DATA FORMS..IF YOU HAVE NOT, PLEASE TURN OFF
THE TERMINAL AND HAVE YOUR DATA READY ON THE DATA FORMS

RUNID,RUNTYP,ASHRAE,IDETAL,METHOD,IRFMTP
RUNID.....IDENTIFICATION OF THE RUN
1 NEED RESPONSE FACTOR DATA

2 SKIP RESPONSE FACTOR DATA
 RUNTYP.....TYPE OF RUN
 1 ENERGY CALCULATION ..NEEDS WEATHER TAPE
 2 DESIGN LOAD CALCULATION
 3 DESIGN AND ENERGY LOAD CALCULATIONS
 ASHRAE.....0 USE RMTMP
 1 USE ASHRAE WEIGHTING FACTORS
 IDETAL.....0 NO DETAILED OUTPUT
 1 DETAILED OUTPUT
 METHOD.....0 REGULAR TREATMENT FOR THE ROOM
 1 SPECIAL TREATMENT OF THE ROOM
 IRFMTP..... OUTPUT TAPE UNIT NO. TO ROSS MERIWETHER
 SYSTEM SIMULATION PROGRAM. IF NO TAPE IS
 DESIRED, IRFMTP=0

CEILING TO COND. SPACE-3.16 W-NO S
 LIGHTING SCHEDULE FOR WEEKDAYS
 EQUIPMENT USAGE SCHEDULE FOR WEEKDAYS
 OCCUPANCY SCHEDULE FOR WEEKDAYS
 LIGHTING SCHEDULE FOR WEEKEND
 EQUIPMENT SCHEDULE FOR WEEKENDS
 OCCUPANCY SCHEDULE FOR WEEKEND
 LIGHTING SCHEDULE FOR THE VACATION PERIOD
 EQUIPMENT USAGE SCHEDULE FOR THE VACATION PERIOD
 OCCUPANCY SCHEDULE FOR THE VACATION PERIOD
 THERMOSTAT SETTING FOR THE COOLING SEASON
 THERMOSTAT SETTING FOR THE HEATING SEASON
 RMDBWO,RMDBSO,RHW,RHS
 DATA SHEET NO 1:NDAY,NSKIP,TAPE2
 DATA SHEET NO 2 & 3 :MONTH,DAY,ELAPS,DBMAX,RANGE,WBMAX,DBMWT,TGS,TGW,UG,LUNG,LAT,TZN,ZLF,RHOW
 DATA SHEET NO 4: NAME OF THE ROOM
 DATA SHEET NO 5:IROT,ISKIP,INCLUDE
 DATA SHEET NO 6 N/L,K,P,C,R
 DATA SHEET NO 7: DESCRIPTION OF EACH LAYER

IRF= 1

WALL COMPOSITION

| LAYER NO | L(I) | K(I) | (I) | C(I) | RES(I) | DESCRIPTION OF LAYERS |
|----------|------|-------|--------|------|--------|-----------------------|
| 1 | .167 | 1.000 | 140.00 | .200 | 0. | 2-" HW CONCRETE |
| 2 | .334 | .025 | 5.70 | .200 | 0. | 4" INSULATION |
| 3 | .031 | .110 | 70.00 | .400 | 0. | 3/8" FELT & MEMBRANE |
| 4 | .042 | .830 | 55.00 | .400 | 0. | 1/2" SLAG |

TIME INCREMENT DT= 1.

THERMAL CONDUCTANCE UT= .072

RESPONSE FACTORS

| J | X | Y | Z |
|---|---------|-------|---------|
| 0 | 4.6018 | .0039 | 1.9307 |
| 1 | -4.3324 | .0375 | -1.8332 |
| 2 | -.1798 | .0241 | -.0213 |
| 3 | -.0150 | .0055 | -.0034 |
| 4 | -.0020 | .0010 | -.0006 |
| 5 | -.0003 | .0002 | -.0001 |
| 6 | -.0001 | .0000 | -.0000 |
| 7 | -.0000 | .0000 | -.0000 |
| 8 | -.0000 | .0000 | -.0000 |

COMMON RATIO CR= .17519

DATA SHEET NO 7: DESCRIPTION OF EACH LAYER

IRF= 2

WALL COMPOSITION

| LAYER NO | L(I) | K(I) | (I) | C(I) | RES(I) | DESCRIPTION OF LAYERS |
|----------|------|--------|--------|------|--------|-----------------------|
| 1 | .005 | 26.000 | 480.00 | .100 | 0. | STEEL SIDING |
| 2 | 0. | 0. | 0. | 0. | .91 | AIR SPACE |
| 3 | .167 | .013 | 2.50 | .380 | 0. | INSULATION MODIFIED |
| 4 | .005 | 26.000 | 480.00 | .100 | 0. | STEEL SIDING |

TIME INCREMENT DT= 1.

THERMAL CONDUCTANCE

UT= .074

RESPONSE FACTORS

| J | X | Y | Z |
|---|--------|-------|--------|
| 0 | .3598 | .0467 | .3705 |
| 1 | -.2851 | .0271 | -.2958 |
| 2 | -.0004 | .0004 | -.0004 |
| 3 | -.0000 | .0000 | -.0000 |
| 4 | -.0000 | .0000 | -.0000 |

COMMON RATIO CR= .01336
 DATA SHEET NO 7: DESCRIPTION OF EACH LAYER

IRF= 3

WALL COMPOSITION

| LAYER NO | L(I) | K(I) | (I) | C(I) | RES(I) | DESCRIPTION OF LAYERS |
|----------|------|-------|--------|------|--------|-----------------------|
| 1 | .500 | 1.000 | 140.00 | .200 | 0. | 6" CONCRETE |
| 2 | .364 | .025 | 5.70 | .200 | 0. | 4.43" INSULATION |

TIME INCREMENT DT= 1.

THERMAL CONDUCTANCE UT= .066

RESPONSE FACTORS

| J | X | Y | Z |
|---|---------|-------|--------|
| 0 | 5.9702 | .0001 | .1906 |
| 1 | -3.5466 | .0043 | -.1088 |
| 2 | -.7415 | .0129 | -.0111 |
| 3 | -.4844 | .0134 | -.0025 |
| 4 | -.3376 | .0104 | -.0007 |
| 5 | -.2367 | .0075 | -.0003 |
| 6 | -.1661 | .0053 | -.0002 |

COMMON RATIO CR= .70105
 DATA SHEET NO 7: DESCRIPTION OF EACH LAYER

IRF= 4

WALL COMPOSITION

| LAYER NO | L(I) | K(I) | (I) | C(I) | RES(I) | DESCRIPTION OF LAYERS |
|----------|------|------|--------|------|--------|-----------------------|
| 1 | .042 | .420 | 100.00 | .200 | 0. | 1/2" GYPSUM BOARD |
| 2 | 0. | 0. | 0. | 0. | .91 | AIR SPACE |
| 3 | .042 | .420 | 100.00 | .200 | 0. | 1/2" GYPSUM BOARD |

TIME INCREMENT DT= 1.

THERMAL CONDUCTANCE UT= .902

RESPONSE FACTORS

| J | X | Y | Z |
|---|--------|-------|--------|
| 0 | 1.6653 | .8321 | 1.6653 |
| 1 | -.7631 | .0701 | -.7631 |
| 2 | 0. | 0. | 0. |
| 3 | 0. | 0. | 0. |
| 4 | 0. | 0. | 0. |

COMMON RATIO CR=0.

DATA SHEET NO 7: DESCRIPTION OF EACH LAYER

IRF= 5

WALL COMPOSITION

| LAYER NO | L(I) | K(I) | (I) | C(I) | RES(I) | DESCRIPTION OF LAYERS |
|----------|------|-------|--------|------|--------|-----------------------|
| 1 | .500 | 1.000 | 140.00 | .200 | 0. | 6" CONCRETE |
| 2 | 0. | 0. | 0. | 0. | 1.00 | CEILING AIR SPACE |

TIME INCREMENT DT= 1.

THERMAL CONDUCTANCE UT= .667

RESPONSE FACTORS

| J | X | Y | Z |
|---|---------|-------|--------|
| 0 | 5.9702 | .0308 | .8739 |
| 1 | -3.5394 | .1876 | -.0879 |
| 2 | -.6987 | .1689 | -.0459 |
| 3 | -.4083 | .1067 | -.0281 |
| 4 | -.2513 | .0660 | -.0173 |
| 5 | -.1552 | .0408 | -.0107 |
| 6 | -.0959 | .0252 | -.0066 |

COMMON RATIO CR= .61750
 DATA SHEET NO 7: DESCRIPTION OF EACH LAYER

IRF= 6

WALL COMPOSITION

| LAYER NO | L(I) | K(I) | (I) | C(I) | RES(I) | DESCRIPTION OF LAYERS |
|----------|------|-------|--------|------|--------|-----------------------|
| 1 | 0. | 0. | 0. | 0. | 1.00 | CEILING AIR SPACE |
| 2 | .500 | 1.000 | 140.00 | .200 | 0. | 6" CONCRETE |

TIME INCREMENT DT= 1.

THERMAL CONDUCTANCE UT= .667

RESPONSE FACTORS

| J | X | Y | Z |
|---|--------|-------|---------|
| 0 | .8739 | .0308 | 5.9702 |
| 1 | -.0879 | .1876 | -3.5394 |
| 2 | -.0459 | .1689 | -.6987 |
| 3 | -.0281 | .1067 | -.4083 |
| 4 | -.0173 | .0660 | -.2513 |
| 5 | -.0107 | .0408 | -.1552 |

COMMON RATIO CR= .61731

CONDUCTION TRANSFER FUNCTIONS FOR IRF= 1

| J | X | Y | Z | CR |
|---|----------|--------|----------|--------|
| 1 | 4.60175 | .00387 | 1.93073 | .17519 |
| 2 | -5.13862 | .03679 | -2.17146 | |
| 3 | .57926 | .01753 | .29987 | |
| 4 | .01645 | .00125 | .00035 | |
| 5 | .00065 | .00005 | .00000 | |
| 6 | .00002 | .00000 | -.00000 | |

CONDUCTION TRANSFER FUNCTIONS FOR IRF= 2

| J | X | Y | Z | CR |
|---|---------|--------|---------|--------|
| 1 | .35979 | .04672 | .37049 | .01336 |
| 2 | -.28990 | .02647 | -.30073 | |
| 3 | .00338 | .00008 | .00350 | |

CONDUCTION TRANSFER FUNCTIONS FOR IRF= 3

| J | X | Y | Z | CR |
|---|----------|--------|---------|--------|
| 1 | 5.97021 | .00007 | .19055 | .70105 |
| 2 | -7.73202 | .00429 | -.24238 | |
| 3 | 1.74482 | .00983 | .06516 | |
| 4 | .03547 | .00437 | .00527 | |
| 5 | .00196 | .00102 | .00102 | |

CONDUCTION TRANSFER FUNCTIONS FOR IRF= 4

| J | X | Y | Z | CR |
|---|---------|----|---------|----|
| 1 | 1.66530 | 0. | 1.66530 | 0. |
| 2 | -.76308 | 0. | -.76308 | |

CONDUCTION TRANSFER FUNCTIONS FOR IRF= 5

| J | X | Y | Z | CR |
|---|----------|--------|---------|--------|
| 1 | 5.97024 | .03084 | .87386 | .61750 |
| 2 | -7.22605 | .16854 | -.62750 | |
| 3 | 1.48689 | .05307 | .00839 | |
| 4 | .02317 | .00242 | .00024 | |
| 5 | .00080 | .00010 | .00001 | |

CONDUCTION TRANSFER FUNCTIONS FOR IRF= 6

| J | X | Y | Z | CR |
|---|---------|--------|----------|--------|
| 1 | .87386 | .03084 | 5.97024 | .61731 |
| 2 | -.62732 | .16855 | -7.22487 | |
| 3 | .00837 | .05311 | 1.48619 | |
| 4 | .00023 | .00245 | .02303 | |

DATA SHEET NO 8: ROOMNO,QLITY,QQPY,QCU,FLCG,FRAS,TS,CFMS,ARCHGS,ARCHGW,ARCHGM,ZNORM
 DATA SHEET NO.9: IW,IL,ISTART,ILEAVE
 DATA SHEET NO 10: TUL,TLL,QCMAX,QHMAX,DBVMAX,DBVMIN
 DATA SHEET NO 11: ITHST,ITK
 DATA SHEET NO 12: NS,NW,NN,NE,L,W,H
 DATA SHEET 13 AND 14: ROOM SURFACE DATA AND EXTERIOR SURFACE SHADOW DATA

| ROOMNO | HT | AG | NOFLR | QCU | ARCHGS | ARCHGW |
|--------|-----|-------|-------|-----|--------|--------|
| 1.0 | 9.0 | 182.3 | 1.0 | 2.0 | .3 | .3 |

LAT 42.0 LONG 87.0 TZN 6.0 ZNORM 1.0

QLITY 3.2 QEOPX 1.0 CFMV 30.0 DBIN 70.0 IG 0. TV 0. DPIN 50.0

NEXP 7 ITK 1 ITHST 1

DATA SHEET NO 15: UENDW,UCELNG,AENDW,ATCHT,AIRCHG,AIRRT
 DATA SHEET NO 16: IEXTSD,IEXMS,IEXME,NTVNT,NVENT

| UENDW | UCELNG | AENDW | ATCHT | IRF | ABSP | U | H | A | WAZ | SHADE | UT | HI |
|-------|--------|-------|-------|-----|------|------|--------|--------|-----|-------|-------|-----|
| 0. | 0. | 0. | 0. | 0. | | | | | | | | |
| 1 | 6 | 1 | 6 | 0. | .46 | 0. | 182.25 | 0. | 0. | 0. | .67 | .54 |
| 2 | 2 | 1 | 2 | .85 | .07 | 6.00 | 91.12 | 0. | 0. | 0. | .07 | .54 |
| 3 | 3 | -1 | 10 | 0. | 1.06 | 6.00 | 30.38 | 0. | 0. | .67 | 10.89 | .54 |
| 4 | 6 | 1 | 4 | 0. | .56 | 0. | 121.50 | 90.00 | 0. | 0. | .90 | .54 |
| 5 | 6 | 1 | 4 | 0. | .56 | 0. | 121.50 | 180.00 | 0. | 0. | .90 | .54 |
| 6 | 6 | 1 | 4 | 0. | .56 | 0. | 121.50 | -90.00 | 0. | 0. | .90 | .54 |
| 7 | 6 | 1 | 5 | 0. | .46 | 0. | 182.25 | 0. | 0. | 0. | .67 | .54 |

SHADOW CASTING DATA

| FL | HT | FP | AW | BWL | BWR | D | FP1 | A1 | B1 | C1 | FP2 | A2 | B2 | C2 |
|----|----|----|----|-----|-----|----|-----|----|----|----|-----|----|----|----|
| 0. | 0. | 0. | 0. | 0. | 0. | 0. | 0. | 0. | 0. | 0. | 0. | 0. | 0. | 0. |
| 0. | 0. | 0. | 0. | 0. | 0. | 0. | 0. | 0. | 0. | 0. | 0. | 0. | 0. | 0. |
| 0. | 0. | 0. | 0. | 0. | 0. | 0. | 0. | 0. | 0. | 0. | 0. | 0. | 0. | 0. |
| 0. | 0. | 0. | 0. | 0. | 0. | 0. | 0. | 0. | 0. | 0. | 0. | 0. | 0. | 0. |
| 0. | 0. | 0. | 0. | 0. | 0. | 0. | 0. | 0. | 0. | 0. | 0. | 0. | 0. | 0. |
| 0. | 0. | 0. | 0. | 0. | 0. | 0. | 0. | 0. | 0. | 0. | 0. | 0. | 0. | 0. |

RADIATION INTERCHANGE FACTORS

| SURFACE | 1 | 2 | 3 | 4 | 5 | 6 | 7 | 8 | 9 | 10 |
|---------|------|------|------|------|------|------|------|---|---|----|
| 1 | 0. | .127 | .043 | .170 | .170 | .170 | .320 | | | |
| 2 | .255 | 0. | 0. | .171 | .148 | .171 | .255 | | | |
| 3 | .255 | 0. | 0. | .171 | .148 | .171 | .255 | | | |
| 4 | .255 | .128 | .043 | 0. | .171 | .148 | .255 | | | |
| 5 | .255 | .111 | .037 | .171 | 0. | .171 | .255 | | | |
| 6 | .255 | .128 | .043 | .148 | .171 | 0. | .255 | | | |

7 .320 .127 .043 .170 .170 .170 0.

HEATING LOAD IN BTU PER HOUR

```

SENSIBLE LOAD = 3917.
LATENT  LOAD = 317.
-----
TOTAL    LOAD = 4234.

```

SOLAR DATA (QSUN/QGLASS)

| | | | | | | | | | | | | | | | | | | | | | | | | | | | | | | | | | | | | | | | |
|----|----|----|----|----|-----|-----|-----|-----|------|------|------|------|------|-----|-----|-----|-----|----|----|----|----|----|----|----|----|----|----|----|----|----|----|----|----|----|----|----|----|----|----|
| 0. | 0. | 0. | 0. | 0. | 0. | 0. | 0. | 0. | 0. | 0. | 0. | 0. | 0. | 0. | 0. | 0. | 0. | 0. | 0. | 0. | 0. | 0. | 0. | 0. | 0. | 0. | 0. | 0. | 0. | 0. | 0. | 0. | 0. | 0. | 0. | 0. | 0. | 0. | |
| 0. | 0. | 0. | 0. | 0. | 0. | 0. | 0. | 0. | 0. | 0. | 0. | 0. | 0. | 0. | 0. | 0. | 0. | 0. | 0. | 0. | 0. | 0. | 0. | 0. | 0. | 0. | 0. | 0. | 0. | 0. | 0. | 0. | 0. | 0. | 0. | 0. | 0. | 0. | |
| 0. | 0. | 0. | 0. | 2. | 13. | 23. | 44. | 80. | 109. | 128. | 133. | 125. | 104. | 73. | 36. | 21. | 11. | 0. | 0. | 0. | 0. | 0. | 0. | 0. | 0. | 0. | 0. | 0. | 0. | 0. | 0. | 0. | 0. | 0. | 0. | 0. | 0. | 0. | 0. |
| 0. | 0. | 0. | 0. | 0. | 0. | 0. | 0. | 0. | 0. | 0. | 0. | 0. | 0. | 0. | 0. | 0. | 0. | 0. | 0. | 0. | 0. | 0. | 0. | 0. | 0. | 0. | 0. | 0. | 0. | 0. | 0. | 0. | 0. | 0. | 0. | 0. | 0. | 0. | 0. |
| 0. | 0. | 0. | 0. | 0. | 0. | 0. | 0. | 0. | 0. | 0. | 0. | 0. | 0. | 0. | 0. | 0. | 0. | 0. | 0. | 0. | 0. | 0. | 0. | 0. | 0. | 0. | 0. | 0. | 0. | 0. | 0. | 0. | 0. | 0. | 0. | 0. | 0. | 0. | 0. |
| 0. | 0. | 0. | 0. | 0. | 0. | 0. | 0. | 0. | 0. | 0. | 0. | 0. | 0. | 0. | 0. | 0. | 0. | 0. | 0. | 0. | 0. | 0. | 0. | 0. | 0. | 0. | 0. | 0. | 0. | 0. | 0. | 0. | 0. | 0. | 0. | 0. | 0. | 0. | 0. |
| 0. | 0. | 0. | 0. | 0. | 0. | 0. | 0. | 0. | 0. | 0. | 0. | 0. | 0. | 0. | 0. | 0. | 0. | 0. | 0. | 0. | 0. | 0. | 0. | 0. | 0. | 0. | 0. | 0. | 0. | 0. | 0. | 0. | 0. | 0. | 0. | 0. | 0. | 0. | 0. |
| 0. | 0. | 0. | 0. | 0. | 0. | 0. | 0. | 0. | 0. | 0. | 0. | 0. | 0. | 0. | 0. | 0. | 0. | 0. | 0. | 0. | 0. | 0. | 0. | 0. | 0. | 0. | 0. | 0. | 0. | 0. | 0. | 0. | 0. | 0. | 0. | 0. | 0. | 0. | 0. |
| 0. | 0. | 0. | 0. | 0. | 0. | 0. | 0. | 0. | 0. | 0. | 0. | 0. | 0. | 0. | 0. | 0. | 0. | 0. | 0. | 0. | 0. | 0. | 0. | 0. | 0. | 0. | 0. | 0. | 0. | 0. | 0. | 0. | 0. | 0. | 0. | 0. | 0. | 0. | 0. |
| 0. | 0. | 0. | 0. | 0. | 0. | 0. | 0. | 0. | 0. | 0. | 0. | 0. | 0. | 0. | 0. | 0. | 0. | 0. | 0. | 0. | 0. | 0. | 0. | 0. | 0. | 0. | 0. | 0. | 0. | 0. | 0. | 0. | 0. | 0. | 0. | 0. | 0. | 0. | 0. |
| 0. | 0. | 0. | 0. | 0. | 0. | 0. | 0. | 0. | 0. | 0. | 0. | 0. | 0. | 0. | 0. | 0. | 0. | 0. | 0. | 0. | 0. | 0. | 0. | 0. | 0. | 0. | 0. | 0. | 0. | 0. | 0. | 0. | 0. | 0. | 0. | 0. | 0. | 0. | 0. |

ROOM NAME= ROOM WITH GLASS AREA FACING SOUTH

MONTH DAY MHR QLMAX CLDAY HLDAY DBA
7 21 14 -4483. -39486. 0. 85.7

***** YEAR = 2000 ***** MONTH = 7 ***** DAY = 21

| TIME | DBOUT | WBOUT | DBIN | RHIN | QLS | QLL |
|------|-------|-------|------|------|-----|-----|
| 1 | 79.6 | 60.9 | 77.6 | 36.1 | 0. | 0. |
| 2 | 78.6 | 60.5 | 77.4 | 36.3 | 0. | 0. |
| 3 | 77.8 | 60.2 | 77.3 | 36.5 | 0. | 0. |

| | | | | | | |
|----|------|------|------|------|--------|-----|
| 4 | 77.2 | 60.0 | 77.1 | 36.7 | 0. | 0. |
| 5 | 77.0 | 60.0 | 77.0 | 36.8 | -0. | 0. |
| 6 | 77.4 | 60.1 | 77.1 | 36.7 | -0. | 0. |
| 7 | 78.4 | 60.4 | 77.3 | 36.5 | -0. | 0. |
| 8 | 80.2 | 61.1 | 75.0 | 50.0 | -2897. | 2. |
| 9 | 82.8 | 62.0 | 75.0 | 50.0 | -3224. | 48. |
| 10 | 85.8 | 63.0 | 75.0 | 50.0 | -3611. | 48. |
| 11 | 89.2 | 64.1 | 75.0 | 50.0 | -3989. | 48. |
| 12 | 92.4 | 65.1 | 75.0 | 50.0 | -4301. | 48. |
| 13 | 94.8 | 65.9 | 75.0 | 50.0 | -4483. | 48. |
| 14 | 96.4 | 66.4 | 75.0 | 50.0 | -4531. | 48. |
| 15 | 97.0 | 66.6 | 75.0 | 50.0 | -4451. | 48. |
| 16 | 96.4 | 66.4 | 75.0 | 50.0 | -4294. | 48. |
| 17 | 95.0 | 65.9 | 75.0 | 50.0 | -4141. | 48. |
| 18 | 92.8 | 65.2 | 79.4 | 34.1 | 0. | 0. |
| 19 | 90.2 | 64.4 | 79.1 | 34.4 | -0. | 0. |
| 20 | 87.6 | 63.6 | 78.8 | 34.8 | -0. | 0. |
| 21 | 85.4 | 62.8 | 78.5 | 35.1 | 0. | 0. |
| 22 | 83.4 | 62.2 | 78.2 | 35.4 | -0. | 0. |
| 23 | 81.8 | 61.6 | 78.0 | 35.7 | -0. | 0. |
| 24 | 80.6 | 61.2 | 77.8 | 35.9 | -0. | 0. |

DBA = 85.74
QLDSUM = -39486.

TOTAL COOLING CONSUMPTION PER DAY = -39486. BTU
TOTAL HEATING CONSUMPTION PER DAY = 0. BTU
TOTAL COOLING CONSUMPTION FOR THE ROOM OVER THE 1 DAY PERIOD = -.39486E+05 BTU
TOTAL HEATING CONSUMPTION FOR THE ROOM OVER THE 1 DAY PERIOD = .42152E-03 BTU
TOTAL COOLING CONSUMPTION FOR 1 ROOMS = -.39486E+05 BTU
TOTAL HEATING CONSUMPTION FOR 1 ROOMS = .42152E-03 BTU
DATA SHEET NO 4: NAME OF THE ROOM

STOP

L

2 CEILING TO COND. SPACE-3.16 W-NO SHADE-25(SOLARGRAY
3 0,0,0,0,0,0,0,1,1,1,1,1,1,1,1,1,1,1,0,0,0,0,0,0,0
4 0,0,0,0,0,0,0,1,1,1,1,1,1,1,1,1,1,1,0,0,0,0,0,0,0
5 0,0,0,0,0,0,0,1,1,1,1,1,1,1,1,1,1,1,0,0,0,0,0,0,0
6 0,0
7 0,0
8 0,0
9 0,0
10 0,0
11 0,0
12 80,80,80,80,80,80,80,80,75,75,75,75,75,75,75,75,75,80,80,80,80,80,80,80
13 60,60,60,60,60,60,60,60,70,70,70,70,70,70,70,70,70,60,60,60,60,60,60,60
14 60,80,20,50
15 31,0,0
16 7,21,201,97,20,67,20,60,50,0.1,87,42,6,13.5,60
17 ROOM WITH GLASS AREA FACING SOUTH

```

18      0,0,0
60      1.0,3.16,1.0,2.0,0.0,0.5,0.0,30.0,0.25,0.25,0.0,1.0
61      3,1,8,17
62      75,60,0,0,70,60
63      1,1
64      2,1,1,1
65      13.5,13.5,9.0
66      6,6,182.25,0,0,0,.85,0
67      0,0,0,0,0,0,0
68      0,0,0,0,0,0,0
69      2,2,91.12,0,0,0,.85,0
70      0,0,0,0,0,0,0
71      0,0,0,0,0,0,0
72      3,10,30.38,0,1.06,.67,0,0
73      0,0,0,0,0,0,0
74      0,0,0,0,0,0,0
75      6,4,121.5,90,0,0,0,0
76      0,0,0,0,0,0,0
77      0,0,0,0,0,0,0
78      6,4,121.5,180,0,0,0,0
79      0,0,0,0,0,0,0
80      0,0,0,0,0,0,0
81      6,4,121.5,-90,0,0,0,0
82      0,0,0,0,0,0,0
83      0,0,0,0,0,0,0
84      6,5,182.25,0,0,0,0,0
85      0,0,0,0,0,0,0
86      0,0,0,0,0,0,0
87      0,0,0,0,0,0
88      0,0,0,6,0

```

Q

CONGRATULATIONS!! NOW YOU ARE ON NBSLD

WE ASSUME YOU HAVE ALREADY PREPARED THE DATA
ON NBS DATA FORMS..IF YOU HAVE NOT, PLEASE TURN OFF
THE TERMINAL AND HAVE YOUR DATA READY ON THE DATA FORMS

```

RUNID,RUNTYP,ASHRAE,IDETAL,METHOD,IRFMTP
RUNID.....IDENTIFICATION OF THE RUN
          1 NEED RESPONSE FACTOR DATA
          2 SKIP RESPONSE FACTOR DATA
RUNTYP.....TYPE OF RUN
          1 ENERGY CALCULATION ..NEEDS WEATHER TAPE
          2 DESIGN LOAD CALCULATION
          3 DESIGN AND ENERGY LOAD CALCULATIONS
ASHRAE.....0 USE RMTMP
          1 USE ASHRAE WEIGHTING FACTORS
IDETAL.....0 NO DETAILED OUTPUT
          1 DETAILED OUTPUT
METHOD.....0 REGULAR TREATMENT FOR THE ROOM

```

1 SPECIAL TREATMENT OF THE ROOM
 IRFMTP..... OUTPUT TAPE UNIT NO. TO ROSS MERIWETHER
 SYSTEM SIMULATION PROGRAM. IF NO TAPE IS
 DESIRED, IRFMTP=0

CEILING TO COND. SPACE-3.16 W-NO S
 LIGHTING SCHEDULE FOR WEEKDAYS
 EQUIPMENT USAGE SCHEDULE FOR WEEKDAYS
 OCCUPANCY SCHEDULE FOR WEEKDAYS
 LIGHTING SCHEDULE FOR WEEKEND
 EQUIPMENT SCHEDULE FOR WEEKENDS
 OCCUPANCY SCHEDULE FOR WEEKEND
 LIGHTING SCHEDULE FOR THE VACATION PERIOD
 EQUIPMENT USAGE SCHEDULE FOR THE VACATION PERIOD
 OCCUPANCY SCHEDULE FOR THE VACATION PERIOD
 THERMOSTAT SETTING FOR THE COOLING SEASON
 THERMOSTAT SETTING FOR THE HEATING SEASON
 RMDRW0,RM0BS0,RHW,RHS
 DATA SHEET NO 1:NDAY,NSKIP,TAPE2
 DATA SHEET NO 2 & 3 :MONTH,DAY,ELAPS,DBMAX,RANGE,WBMAX,DBMWT,TGS,TGW,UG,LONG,LAT,IZN,ZLF,RHOW
 DATA SHEET NO 4: NAME OF THE ROOM
 DATA SHEET NO 5:IROT,ISKIP,INCLUDE
 DATA SHEET NO 8: ROOMNO,QLITY,QQPY,UCU,FLCG,FRAS,TS,CFMS,ARCHGS,ARCHGW,ARCHGM,ZNORM
 DATA SHEET NO.9: IW,IL,ISTART,ILEAVE
 DATA SHEET NO 10: TUL,TLL,QCMAX,QHMAX,DBVMAX,DBVMIN
 DATA SHEET NO 11: ITHST,ITK
 DATA SHEET NO 12: NS,NW,NN,NE,L,W,H
 DATA SHEET 13 AND 14: ROOM SURFACE DATA AND EXTERIOR SURFACE SHADOW DATA
 DATA SHEET NO 15: UENDW,UCELNG,AENDW,ATCHT,AIRCHG,AIRNT
 DATA SHEET NO 16: IEXTSD,IEXMS,IEXME,NTVNT,NVENT

ROOM NAME= ROOM WITH GLASS AREA FACING SOUTH

| MONTH | DAY | MHR | QLMAX | CLDAY | HLDAY | DBA |
|-------|-----|-----|--------|--------|--------|------|
| 1 | 1 | 13 | 0. | -0. | 0. | 33.4 |
| 1 | 2 | 8 | 2558. | -0. | 13858. | 24.0 |
| 1 | 3 | 8 | 2625. | -0. | 10834. | 28.8 |
| 1 | 4 | 15 | -1074. | -4118. | 3971. | 41.8 |
| 1 | 5 | 6 | 0. | -0. | 0. | 36.1 |
| 1 | 6 | 20 | 0. | -0. | 0. | 31.3 |
| 1 | 7 | 8 | 2023. | -0. | 10091. | 35.5 |
| 1 | 8 | 8 | 1723. | -0. | 9349. | 35.5 |
| 1 | 9 | 8 | 1372. | -0. | 4460. | 36.7 |
| 1 | 10 | 12 | -256. | -316. | 4195. | 37.6 |
| 1 | 11 | 8 | 2710. | -0. | 16146. | 28.5 |
| 1 | 12 | 16 | 0. | -0. | 0. | 32.6 |
| 1 | 13 | 15 | 0. | -0. | 0. | 37.5 |
| 1 | 14 | 8 | 2667. | -0. | 13764. | 24.4 |
| 1 | 15 | 9 | 3459. | -0. | 24939. | 17.4 |

| | | | | | | |
|---|----|----|--------|--------|--------|------|
| 1 | 16 | 9 | 3366. | -0. | 16866. | 22.8 |
| 1 | 17 | 10 | 3425. | -0. | 26931. | 13.8 |
| 1 | 18 | 8 | 2763. | -0. | 17555. | 18.2 |
| 1 | 19 | 12 | 0. | -0. | 0. | 25.0 |
| 1 | 20 | 15 | 0. | -0. | 0. | 32.5 |
| 1 | 21 | 8 | 1784. | -461. | 4521. | 40.3 |
| 1 | 22 | 15 | -957. | -5860. | 625. | 48.6 |
| 1 | 23 | 10 | -1143. | -6187. | 698. | 49.1 |
| 1 | 24 | 8 | 2975. | -0. | 16799. | 25.4 |
| 1 | 25 | 8 | 2195. | -0. | 12361. | 30.0 |
| 1 | 26 | 12 | 0. | -0. | 0. | 38.5 |
| 1 | 27 | 8 | 0. | -0. | 0. | 40.8 |
| 1 | 28 | 8 | 1516. | -0. | 7301. | 37.2 |
| 1 | 29 | 8 | 1434. | -0. | 5529. | 38.5 |
| 1 | 30 | 8 | 1682. | -0. | 8781. | 38.0 |
| 1 | 31 | 8 | 1548. | -0. | 7599. | 35.2 |

TOTAL COOLING CONSUMPTION FOR 1 ROOMS = -.16941E+05 BTU
TOTAL HEATING CONSUMPTION FOR 1 ROOMS = .23717E+06 BTU
DATA SHEET NO 4: NAME OF THE ROOM
STOP

10. Appendix D

Fortran Listing of NBSLD

Although the attached Fortran listing of the NBSLD routine basically embodies the algorithms of Appendix A, some of the subroutines are considerably simplified if compared with the exact adaptation of Appendix A.

It is cautioned also that the Fortran used herein is the INFONET version of Fortran V, which is somewhat different from the ANSI standard Fortran.

```
1          SUBROUTINE ABCD2 (Z,K,L,G,A,B,C,D,NL)
2          DIMENSION AX(10),BX(10),CX(10),DX(10),G(10)
3          REAL K(10),L(10)
4          PI=4.*ATAN(1.)
5          PP=PI*0.5
6          DO 50 I=1,NL
7              IF (G(I)) 40,40,10
8          10      IF (7) 30,30,20
9          20      ZQ=SQRT(Z/G(I))
10             ZQL=ZQ*L(I)
11             CO=SIN(ZQL)
12             C1=COS(ZQL)
13             S1=CO/ZQL
14             S2=(S1-C1)/ZQL/ZQL
15             AX(I)=C1
16             BX(I)=L(I)/K(I)*S1
17             CX(I)=-ZQL*K(I)/L(I)*CO
18             DX(I)=C1
19             GO TO 50
20          30      AX(I)=1.
21             CX(I)=0.
22             DX(I)=1.
23             BX(I)=L(I)/K(I)
24             GO TO 50
25          40      AX(I)=1.
26             BX(I)=1/K(I)
27             CX(I)=0.
28             DX(I)=1.
29          50      CONTINUE
30             A=AX(I)
31             B=BX(I)
32             C=CX(I)
33             D=DX(I)
34             IF (NL.LT.2) GO TO 60
35             CALL MULT (AX,BX,CX,DX,A,B,C,D,NL)
36          60      RETURN
37             END
```

```
1      SUBROUTINE ABCDP2 (Z,K,L,G,AP,RP,CP,DP)
2      REAL K,L
3      PI=4.*ATAN(1.)
4      IF (G) 30,30,10
5      10  PP=PI/4./G
6      IF (7) 40,40,20
7      20  ZQ=SQRT(Z/G)
8      ZQL=ZQ*L
9      X=L*L*0.5/G
10     RES=L/K
11     C0=SIN(ZQL)
12     C1=COS(ZQL)
13     S1=C0/ZQL
14     S2=(S1-C1)/ZQL/ZQL
15     AP=X*S1
16     RP=X*RES*S2
17     CP=X*(S1+C1)/RES
18     DP=X*S1
19     GO TO 50
20     30  AP=0.
21     RP=0.
22     CP=0.
23     DP=0.
24     GO TO 50
25     40  CONTINUE
26     X=L*L*0.5/G
27     AP=X
28     RP=X*L/K/3
29     CP=K/L*X*2.
30     DP=X
31     GO TO 50
32     50  RETURN
33     END
```

```
1 SUBROUTINE ADJUST(QL,QLATNT,MONTH,NK,JJ)
2 IF(MONTH.GE.6.AND.MONTH.LE.9) GO TO 1
3 IF(QL) 2,2,4
4 2 IF(JJ.GT.1) GO TO 5
5 IF(NK.LT.8.OR.NK.GT.17) GO TO 5
6 4 RETURN
7 1 IF(QL) 6,5,5
8 6 IF(JJ.GT.1) GO TO 5
9 IF(NK.LT.8.OR.NK.GT.17) GO TO 5
10 RETURN
11 5 QL=0.
12 QLATNT=0.
13 RETURN
14 END
```

```

1      SUBROUTINE ATTIC (X,Y,Z,CR,NR,UX,FO,DB,QSUN,QSKY,TOS,TI,TNEW,TA,TIM,Q%
2      RFO,QRFI,QO,QI,UENDW,UCELNG,AENDW,AROOF,ATCHT,ATCAG)
3      % THIS ROUTINE CALCULATES HEAT INPUT TO THE ROOM BELOW THE
4      % ATTIC CEILING. IT ALSO CALCULATES ATTIC TEMPERATURE
5      % X,Y,7 RESPONSE FACTORS FOR ROOF... INSIDE SURFACE THERMAL
6      % RESISTANCE IS INCLUDED
7      % CR COMMON RATIO OF THE ROOF RESPONSE FACTORS
7.1    % NR NUMFR OF SIGNIFICANT RESPONSE FACTORS TO BE USED
8      % UX ROOF OVER ALL HEAT CONDUCTANCE EXCLUDING THE EXTERIOR SURFACE
9      % THERMAL RESISTANCE
10     % FO ROOF EXTERIOR SURFACE THERMAL TRANSFER COEFFICIENT
11     % DB OUTDOOR DRY-BULB TEMPERATURE
12     % QSUN SOLAR RADIATION OVER THE ROOF
13     % QSKY RADIATION TO THE SKY
14     % TOS ROOF SURFACE TEMPERATURE HISTORY
15     % TI ATTIC TEMPERATURE HISTORY
16     % TONEW NEW OUTSIDE SURFACE TEMPERATURE
17     % TINFW NEW ATTIC TEMPERATURE
18     % QRFO HEAT CONDUCTED INTO THE ROOF SURFACE
19     % QRFT HEAT CONDUCTED INTO THE ATTIC FROM THE ROOF
20     % QO,QI HEAT CONDUCTED INTO THE ROOM BELOW THE ATTIC
21     % UENDW OVERALL HEAT TRANSFER COEFFICIENT OF THE END WALL
22     % UCELNG OVERALL HEAT TRANSFER COEFFICIENT OF THE CEILING
23     % BETWEEN THE ATTIC AIR AND ROOM AIR BELOW
24     % AENDW AREA OF THE ATTIC END WALLS
25     % AROOF TOTAL AREA OF THE CEILING
26     % ATCHT ATTIC HEIGHT
27     % ATCAG ATTIC AIR CHANGE PER HOUR
28     % ALL UNITS IN ENGLISH UNIT ALL LENGTH IN FT
29     DIMENSION TOS(1),TI(1),X(1),Y(1),Z(1),FOY(50)
30     CFM=ATCHT*AROOF*ATCAG/60.
31     BB=NR-TIM
32     TAM=TA-TIM
33     XNUM=QSUN-QSKY+FO*BB
34     YNUM=UENDW*BB*AENDW+1.08*CFM*BB+UCELNG*TAM*AROOF
35     YDEN=UENDW*AENDW+UCELNG*AROOF+1.08*CFM
36     IF (NR.GT.1) GO TO 20
37     TAM=TI(1)
38     TONEW=(XNUM+UX*TAM)/(UX+FO)
39     QRFO=UX*(TAM-TONEW)
40     QRFT=QRFO
41     TINFW=(YNUM+UX*AROOF*TONEW)/(YDEN+UX*AROOF)
42     TOS(1)=TONEW
43     QO=UCELNG*(TAM-TINFW)
44     QI=QO
45     TI(1)=TINFW
46     RETURN
47     DO 30 J=2,NR
48     TOY(J)=TI(J-1)
49     DO 40 J=2,NR

```



```

50      40      TI ( J ) = T0Y ( J )
51          SUMX = 0.
52          SUM7 = 0.
53          SUMY = Y ( 1 ) * TI ( 1 )
54          SUMXY = 0.
55          DO 50 J = 2, NR
56          SUMY = SUMY + Y ( J ) * TI ( J )
57          SUMX = SUMX + X ( J ) * TI ( J )
58          SUMXY = SUMXY + Y ( J ) * TOS ( J )
59      50      SUM7 = SUMZ + Z ( J ) * TOS ( J )
60          XNUM = XNUM + SUMY - SUMZ + CR * QRFO
61          TINFW = XNUM / ( Z ( 1 ) + FO )
62          TOS ( 1 ) = TONE *
63          SUM7 = SUMZ + Z ( 1 ) * TOS ( 1 )
64          SUMXY = SUMXY + Y ( 1 ) * TOS ( 1 )
65          QRFO = SUMY - SUMZ + CR * QRFO
66          QRFT = SUMX - SUMXY + CR * QRFI
67          SUMX = 0.
68          SUMY = Y ( 1 ) * TOS ( 1 )
69          DO 60 J = 2, NR
70          SUMX = SUMX + X ( J ) * TI ( J )
71      60      SUMY = SUMY + Y ( J ) * TOS ( J )
72          YNUM = YNUM - AR00F * ( SUMX - SUMY + CR * QRFI )
73          YDEN = AR00F * X ( 1 ) + YDEN
74          TINFW = YNUM / YDEN
75          SUMX = SUMX + TINFW * X ( 1 )
76          QRFT = SUMX - SUMY + CR * QRFI
77          QO = UCCLNG * ( TAM - TINEW )
78          QI = QO
79          TI ( 1 ) = TINEW
80          RETURN
81          END

```

```

1      FUNCTION CCF(IS,CA,TOC,TCA,P,Q,R,CC)
2      DIMENSION CA(4,3),TOC(4,3)
3      DIMENSION PP(4)/1.06,0.96,0.95,1.14/
4      DIMENSION QQ(4)/.012,.033,.030,.003/
5      DIMENSION RR(4)/-.0084,-.0106,-.0108,-.0082/
6      %   IS: SEASON INDEX (1=SPRING, 2=SUMMER, 3=AUTUMN, 4=WINTER)
7      %   CA(I,J): AMOUNT OF I-TH TYPE CLOUD AT J-TH LAYER
8      %   TOC(I,J): I-TYPE CLOUD AT J-TH LAYER
9      %   TCA: TOTAL CLOUD AMOUNT
10     %   CC: CLOUD COVER
11     %   CCF: CLOUD COVER FACTOR
12     %   P,Q,R: TABLE A-6, PAGE 16A, NBSLD REF. MANUAL
13     X=0
14     DO 1 I=1,4
15     DO 1 J=1,3
16     1 X=X+CA(I,J)
17     CC=TCA-0.5*X
18     P=PP(IS)
19     Q=QQ(IS)
20     R=RR(IS)
21     CCF=P+(Q*CC+R*CC**2)
22     RETURN
23     END

```

```
1      FUNCTION CCM (SALT,NTYPE,TC)
2      REAL CC1(10)/.60,.60,.58,.58,.57,.53,.49,.43,.35,.27/
3      REAL CC2(10)/.88,.88,.88,.87,.85,.83,.79,.73,.61,.46/
4      REAL CC3(10)/.84,.83,.83,.82,.80,.79,.74,.67,.60,.49/
5      REAL CC4(10)/1..1..1..1..1..99..98..95..90..84..74/
6      ITC=TC
6.1    IF (ITC.NE.0) GO TO 5
6.2    CCM=1.
6.3    GO TO 50
6.4    5 CONTINUE
7      IF (SALT-45.) 30,30,10
8      10 - IF (NTYPE.EQ.0) GO TO 20
9      CCM=CC2(ITC)
10     GO TO 50
11     20 CCM=CC4(ITC)
12     GO TO 50
13     30 IF (NTYPE.EQ.0) GO TO 40
14     CCM=CC1(ITC)
15     GO TO 50
16     40 CCM=CC3(ITC)
17     50 RETURN
18     END
```

DBRH-PNC

PAGE 1

```
1 SUBROUTINE DRRH(DB,RH,W)
2 PVS=PVSF(DB)
3 PV=RH*PVS/100.
4 W=0.622*PV/(29.92-PV)
5 RETURN
6 END
```

DBRH-PNC

PAGE 1

```

1          SUBROUTINE DECODE(WPOSX,WLONGX,NUM,OUTPUT,MM,YR,MO,DAY,LOCAL)
2          % THIS SUBROUTINE PRODUCES HOURLY DATA OF UP TO 10 WEATHER
3          % PARAMETERS FOR A GIVEN YEAR,MO AND DATE
4          % TAPE POSOTION FOR EACH OF TEN PARAMETERS ARE
5          %
6          % WIND SPEED          WPOSX          WLONGX
7          % WIND DIRECTION      11            2
8          % DRY-BULB TEMP        16            3
9          % WET-BULB TEMP        19            3
10         % DEW-POINT TEMP       22            3
11         % BAROMETRIC PRESS     34            4
12         % TOTAL CLOUD AMOUNT   43            1
13         % PANUE CLOUD COVER    44            1
14         % PRECIPITATION(LIQUID) 68          2
15         % PRECIPITATION(FRZ)   70          3
16         % TAPE POSITION ON TAPE 280
17         % SOLAR DATA          14            4
18         % ELEVATION ANGLE      18            2
19         % TOTAL CLOUD          42            1
20         % 1ST LAYER TYPE OF CLOUD 46        1
21         % YR          YEAR
22         % MO          MONTH
23         % DAY         DAY
24         INTEGER INPUT(1100),IPS(24),ICAR(2000),WPOS,WLONG,OUTPUT(24,10)
25         .YR,DAY,WORD,WPOSX(10),WLONGX(10)
27         IASS=1000000
29         DO 10 I=1,4
30         CALL WDNEW(INPUT)
31         DO 10 JJ=1,498
32         KK=498*(I-1)+JJ
33         10 ICAR(KK)=INPUT(JJ)
34         DO 20 I=1,15
35         IW=ICAR(I)
36         CALL WDX(IW)
37         20 ICAR(I)=IW
38         YR=ICAR(19)*10+ICAR(11)+1900
39         MO=ICAR(12)*10+ICAR(13)
40         DAY=ICAR(14)*10+ICAR(15)
41         LOCAL=ICAR(9)
42         IPWR=1
43         DO 18 I=1,4
44         IPWR=IPWR*10
45         18 LOCAL=LOCAL+ ICAR(9-I)*IPWR
46         DO 402 KU=1,NUM
47         WPOS=WPOSX(KU)
48         WLONG=WLONGX(KU)
49         502 DO 2 I=1,6
50         IPS(J)=15+WPOS+R0*(I-1)
51         DO 2 J=1,3
52         II=I+J*6

```

```
53      2 IPS(II)=IPS(I)+J*498
54      DO 3 I=1,24
55      KI=IPS(I)
56      KL=KI+WLONG- 1
57      DO 401 L2=KI,KL
58      IW=ICHAR(L2)
59      CALL WDX(IW)
60      401 ICHAR(L2)=IW
61      LONG=WLONG-1
62      IF (ICCHAR(KI).EQ.IASS.AND.WLONG.GT.1) LONG=WLONG-2
63      WORD=ABS(ICCHAR(KL))
64      IF (LONG.EQ.0) GO TO 3
65      IPWR=1
66      DO 5 JK=1, LONG
67      IPWR=IPWR*10
68      5 WORD=WORD+ICCHAR(KL-JK)*IPWR
69      IF (ICCHAR(KL).LT.0) WORD=-WORD
70      3 OUTPUT(I,KU)=WORD
71      402 CONTINUE
72      RETURN
138      END
```



```

1          SUBROUTINE DERVT (A,R,C,D,AP,RP,CP,DP,APP,BPP,CPP,DPP,N)
2          DIMENSION A(N),R(N),C(N),D(N),AP(N),RP(N),CP(N),DP(N),AT(10),BT(10%
3          ),CT(10),DT(10),ATT(10),RTT(10),CTT(10),DIT(10)
4          DO 20 I=1,N
5          DO 20 J=1,N
6          IF (I.EQ.J) GO TO 10
7          AT(I)=A(J)
8          RT(I)=R(J)
9          CT(I)=C(J)
10         DT(I)=D(J)
11         GO TO 20
12         10  AT(I)=AP(J)
13            RT(I)=RP(J)
14            CT(I)=CP(J)
15            DT(I)=DP(J)
16         20  CONTINUE
17         30  CALL MULT (AT,RT,CT,DT,ATT(I),RTT(I),CTT(I),DIT(I),N)
18            APP=ATT(I)
19            BPP=RTT(I)
20            CPP=CTT(I)
21            DPP=DIT(I)
22         DO 40 I=2,N
23            APP=APP+ATT(I)
24            BPP=BPP+RTT(I)
25            CPP=CPP+CTT(I)
26         40  DPP=DPP+DIT(I)
27         RETURN
28         END

```

```
1          FUNCTION DPF (PV)
2          * THIS SUBROUTINE CALCULATES DEW-POINT TEMPERATURE FOR GIVEN VAPOR PRE
2.1         IF (PV) 1.1.2
2.2         1 GO TO 20
2.3         2 CONTINUE
3          Y=LOG(PV)
4          IF (PV.GT.0.1836) GO TO 10
5          DPF=71.98+24.873*Y+0.8927*Y*Y
6          GO TO 20
7          10 DPF=79.047+30.579*Y+1.8893*Y*Y
8          20 RETURN
9          END
```

```
1          SUBROUTINE DST (YR,MO,DAY,DSTX,DSTY)
2          INTEGER YR,DAY,DSTX,DSTY
3          NDAY=WKDAY(YR,MO,DAY)
4          IF (MO.LT.4.OR.MO.GT.10) GO TO 10
5          IF (MO.EQ.4.AND.DAY.LT.24) GO TO 10
6          IF (NDAY.EQ.1) DSTX=DAY
7          IF (MO.EQ.10.AND.DAY.LT.24) GO TO 10
8          IF (NDAY.EQ.1) DSTY=DAY
9          10  CONTINUE
10         RETURN
11        END
```

```
1.      SUBROUTINE ERROR(IDATA,K)
2.      DIMENSION MAX(10)/100,100,150,150,150,3500,10,10,99,999/
3.      DIMENSION MIN(10)/0,0,-40,-40,-40,2000,0,0,0,0/,IDATA(24)
4.      DO 1 J=1,24
5.      IZ=IDATA(J)
6.      IF (I7.GT.MAX(K)) GO TO 1
7.      IF (I7.LT.MIN(K)) GO TO 1
8.      GO TO 2
9.      1 CONTINUE
10     2 IDATA(1)=IZ
11     DO 4 J=2,24
12     IZ=IDATA(J)
13     IF (I7.GT.MAX(K)) GO TO 3
14     IF (I7.LT.MIN(K)) GO TO 3
15     GO TO 4
16     3 IDATA(J)=IDATA(J-1)
17     4 CONTINUE
18     RETURN
19     END
```

```
1          FUNCTION F (A,H,C)
2          %      HC = RECEIVING SURFACE
3          %      AB = SENDING SURFACE
4          %      F(A,H,C) = FROM AH TO BC
5          %      (A*B)*F(A,H,C) = (H*C)*F(C,H,A)
6          %      F(C,R,A) = F(A,H,C)*A/C
7          PI=3.14159
8          X=A/R
9          Y=C/R
10         Z=X*X+Y*Y
11         A2=ALOG((1.+X*X)*(1.+Y*Y)/(1.+Z))
12         A3=Y*Y*ALOG(Y*Y*(1.+Z)/(1.+Y*Y)/Z)
13         A4=X*X*ALOG(X*X*(1.+Z)/(1.+X*X)/Z)
14         A5=Y*ATAN(1./Y)
15         A6=Y*ATAN(1./X)
16         A7=SQRT(Z)*ATAN(1./SQRT(Z))
17         SUM=(A2+A3+A4)/4.+A5+A6-A7
18         F=SUM/PI/Y
19         RETURN
20        END
```

```

1      SURROUTINE FCTR (L,W,H,SF)
2      REAL L,SF(6,6)
3      % THIS ROUTINE CALCULATES BASIC RADIATION SHAPE FACTORS FOR A ROOM.
4      % RADIATION SHAPE FACTOR F(H,L,W)=(H*L)---*(L*W)
5      % TO          FROM      C          S          W          N          E
6      % C          CEILING      0          FHLW      FHWL      FHLW      FHWL
7      % S          SOUTH WALL   FWLH      0          FHWL      RMS       FHWL
8      % W          WEST WALL    FLWH      FLHW      0          FLHW      RMW
9      % N          NORTH WALL   FWLH      RMN       FHWL      0         FHWL
10     % E          EAST WALL    FLWH      FLHW      RME       FLHW      0
11     % F          FLOOR        RMF       FHLW      FHWL      FHLW      FHWL
12     %
13     %          RM = REMAINDER
14     FHLW=F(H,L,W)
15     FHWL=F(H,W,L)
16     FWLH=F(W,L,H)
17     FWHL=F(W,H,L)
18     FLWH=F(L,W,H)
19     FLHW=F(L,H,W)
20     RMC=1.-2.*(FHLW+FHWL)
21     RMS=1.-2.*(FWLH+FHWL)
22     RMW=1.-2.*(FLWH+FLHW)
23     RMN=RMS
24     RME=RMW
25     RMF=RMC
26     SF(1,1)=0.
27     SF(1,2)=FHLW
28     SF(1,3)=FHWL
29     SF(1,4)=FHLW
30     SF(1,5)=FHWL
31     SF(1,6)=RMC
32     SF(2,1)=FWLH
33     SF(2,2)=0.
34     SF(2,3)=FHWL
35     SF(2,4)=RMS
36     SF(2,5)=FHWL
37     SF(2,6)=FWLH
38     SF(3,1)=FLWH
39     SF(3,2)=FLHW
40     SF(3,3)=0.
41     SF(3,4)=FLHW
42     SF(3,5)=RMW
43     SF(3,6)=FLWH
44     SF(4,1)=FWLH
45     SF(4,2)=RMN
46     SF(4,3)=FHWL
47     SF(4,4)=0.
48     SF(4,5)=FHWL
49     SF(4,6)=FWLH
50     SF(5,1)=FLWH

```

FCTR-PNC

PAGE 2

| | |
|----|----------------|
| 51 | SF (5,2) =FLHW |
| 52 | SF (5,3) =RME |
| 53 | SF (5,4) =FLHW |
| 54 | SF (5,5) =0. |
| 55 | SF (5,6) =FLWH |
| 56 | SF (6,1) =RMF |
| 57 | SF (6,2) =FHLW |
| 58 | SF (6,3) =FHWL |
| 59 | SF (6,4) =FHLW |
| 60 | SF (6,5) =FHWL |
| 61 | SF (6,6) =0. |
| 62 | RETURN |
| 63 | END |

FCTR-PNC

PAGE 2

```
1      %      THIS SUBROUTINE CALCULATES OUTSIDE SURFACE HEAT TRANSFER
2      %      COEFFICIENTS,FOT AND FOC
3      %      FOT.... RADIATION PLUS CONVECTION
4      %      FOC....CONVECTION
5      %      V.....WIND VWLOCITY IN KNOTS
6      %      SUBROUTINE FO (V,IS,FOC,FOT,IWD)
7      %      DIMENSION A(6)/0.,0.001,0.,-0.002,0.,-0.00125/,B(6)/.464,0.320,0.38
8      %      30,0.315,0.244,0.262/,C(6)/2.04,2.20,1.90,1.45,1.80,1.45/
9      %      VP=V*.153
10     %      FOT=A(IS)*VP*VP+B(IS)*VP+C(IS)
11     %      IWD=1  IF THE SURFACE IS WINDWARD OR PARALLEL TO THE WIND
12     %      IWD=0  IF THE SURFACE IS LEEWARD
13     %      IF (IWD.EQ.0) GO TO 20
14     %      IF (VP-7.0) 20,20,10
15     10     FOC=0.23*VP+1.02
16     GO TO 30
17     20     FOC=2.63
18     30     RETURN
19     END
```

```
1 SUBROUTINE GLASS(SHADOW,SHDCF,GLTYP,GLAZE,SHGF)
2 DIMENSION TR(9),SH(25)
3 REAL LAT, LONG
4 COMMON /SOL/ LAT, LONG, TZN, WAZ, WT, CN, DST, LPYR, S(35)
5 TR(7)=S(19)
6 TR(8)=GLTYP
7 TR(9)=GLAZE
8 CALL TAR (TR)
9 SH(1)=S(24)
10 SH(2)=S(22)
11 SH(3)=S(23)
12 SH(4)=S(19)
13 SH(5)=0.5
14 SH(6)=0.5
15 SH(7)=0.25
16 SH(8)=0.
17 SH(9)=0.7
18 SH(10)=SHADOW
19 SH(11)=SHDCF
20 SH(12)=TR(1)
21 SH(13)=TR(2)
22 SH(14)=TR(3)
23 SH(15)=TR(5)
24 SH(16)=TR(4)
25 SH(17)=TR(6)
26 CALL SHG (SH)
27 SHGF=SH(18)
28 RETURN
29 END
```

```
1      SUBROUTINE GPF (U,ZL,Z)
2      DIMENSION Z(1)
3      PI=4.*ATAN(1.)
4      SQTP1=SQRT(PI)
5      PI2=2./PI
6      EB=0.001
7      DB=0.1
8      WRITE (6,30)
9      WRITE (6,40)
10     Z(1)=2*ZL*SQRT(U)/SQTP1
11     ZZ=7(1)
12     Z(2)=Z(1)*(SQRT(2.)-2.)
13     DO 10 K=3,50
14     ZK=K
15     10  Z(K)=Z(1)*(SQRT(ZK)-2.*SQRT(ZK-1)+SQRT(ZK-2.))
16     DO 20 K=1,50
17     20  WRITE (6,50) K,Z(K)
18     RETURN
19     %
20     %
21     %
22     30  FORMAT (50H0  RESPONSE FACTORS FOR  SEMI-INFINITE BED
23     40  FORMAT (50H0           K           Z(K)
24     50  FORMAT (11I10,3F10.5)
25     END
```

```
1      SUBROUTINE HOLIDAY (YR,MO,DAY,NDAY,HOL)
2      INTEGER YR,DAY,HOL,WKDAY
3      NDAY=WKDAY(YR,MO,DAY)
4      HOL=0
5      IF (MO.EQ.1.AND.DAY.EQ.1) HOL=1
6      IF (MO.EQ.12.AND.DAY.EQ.31.AND.NDAY.EQ.6) HOL=1
7      IF (MO.EQ.1.AND.DAY.EQ.2.AND.NDAY.EQ.2) HOL=1
8      IF (MO.EQ.2.AND.DAY.EQ.22) HOL=1
9      IF (MO.EQ.2.AND.DAY.EQ.21.AND.NDAY.EQ.6) HOL=1
10     IF (MO.EQ.2.AND.DAY.EQ.23.AND.NDAY.EQ.2) HOL=1
11     IF (MO.EQ.5.AND.DAY.EQ.30) HOL=1
12     IF (MO.EQ.5.AND.DAY.EQ.29.AND.NDAY.EQ.6) HOL=1
13     IF (MO.EQ.5.AND.DAY.EQ.31.AND.NDAY.EQ.2) HOL=1
14     IF (MO.EQ.7.AND.DAY.EQ.4) HOL=1
15     IF (MO.EQ.7.AND.DAY.EQ.3.AND.NDAY.EQ.6) HOL=1
16     IF (MO.EQ.7.AND.DAY.EQ.5.AND.NDAY.EQ.2) HOL=1
17     IF (MO.EQ.12.AND.DAY.EQ.25) HOL=1
18     IF (MO.EQ.12.AND.DAY.EQ.24.AND.NDAY.EQ.6) HOL=1
19     IF (MO.EQ.12.AND.DAY.EQ.26.AND.NDAY.EQ.2) HOL=1
20     IF (MO.EQ.9.AND.DAY.LT.7.AND.NDAY.EQ.2) HOL=1
21     IF (MO.EQ.11.AND.DAY.GT.24.AND.NDAY.EQ.5) HOL=1
22     RETURN
23     END
```

```
1      SUBROUTINE MULT (A,B,C,D,AT,BT,CT,DT,N)
2      DIMENSION A(N),B(N),C(N),D(N)
3      ATT=A(1)
4      BTT=B(1)
5      CTT=C(1)
6      DTT=D(1)
7      IF (N.LT.2) GO TO 20
8      DO 10 J=2,N
9      AT=ATT*A(J)+BTT*C(J)
10     BT=ATT*B(J)+BTT*D(J)
11     CT=CTT*A(J)+DTT*C(J)
12     DT=CTT*B(J)+DTT*D(J)
13     ATT=AT
14     BTT=BT
15     CTT=CT
16     DTT=DT
17     GO TO 30
18     20  AT=ATT
19        BT=BTT
20        CT=CTT
21        DT=DTT
22     30  RETURN
23     END
```



```

1      % .....NBSLD.....
2      % THIS IS THE ROOM TEMPERATURE CALCULATION ROUTINE
3      % OF THE NATIONAL BUREAU OF STANDARDS
4      % NBSLD IS A RESEARCH PROGRAM OF NBS FOR THE PURPOSE OF
5      % STUDYING HEATING AND COOLING LOAD AND ROOM TEMPERATURE
6      % OF BUILDING UNDER ACTUAL WEATHER CONDITION
7      %
8      % A(I) AREA OF SURFACE I, FT2
9      % ARSP(I) SOLAR HEAT ABSORPTION COEFFICIENT FOR SURFACE I.
10     % THIS DATA REQUIRED FOR OPAQUE SURFACES ONLY.
11     % AENOM AREA OF THE ATTIC END WALL, FT2
12     % AG GROUND HEAT TRANSFER AREA, FT2 (MAY=0.)
13     % AIRCHG NO. OF ATTIC AIR CHANGES PER HR, DAYTIME
14     % AIRPT ATTIC NIGHT TIME AIR CHANGE MULTIPLIER
15     % ARCHGS NO. OF AIR CHANGES PER HR IN SUMMER
16     % ARCHGW NO. OF AIR CHANGES PER HR IN WINTER
17     % ATCAGG NO. OF ATTIC AIR CHANGES PER HR (DAY OR NIGHT)
18     % AVFHTG AVERAGE HOURLY HEAT GAIN ENTIRE BUILDING, BTU/HR
19     % AZW(I) WALL AZIMUTH ANGLE FOR SURFACE I, DEGREES
20     % SOUTH = 0.
21     % WEST = 90.
22     % NORTH = 180.
23     % EAST = -90.
24     % BLDMAX BUILDING MAXIMUM SENSIBLE HEAT GAIN, BTU/HR
25     % CFM1 SUMMER INFILTRATION RATE, FT3/MIN.
26     % CFMV VENTILATION RATE, FT3/MIN.
27     % CFMW1 WINTER INFILTRATION, FT3/MIN.
28     % CLDAY DAILY TOTAL ENERGY CONSUMPTION FOR A GROUP
29     % (NORM OF THEM) OF ROOMS OF THE SAME CONFIG-
30     % URATION, BTU
31     % CLDSUM RUNNING TOTAL ENERGY CONSUMPTION FOR COOLING OF
32     % ALL THE ROOMS IN A BUILDING OVER A SET TIME
33     % PERIOD, BTU
34     % CN CLEARNESS NUMBER
35     % CR(L) RESPONSE FACTOR COMMON RATIO FOR CONSTRUCTION L
36     % DAY OF YEAR
37     % DAYSKP NO. OF DAYS TO BE SKIPPED FROM THE WEATHER TAPE
38     % (FROM ITS LAST STARTING POSITION)
39     % DR(I) OUTDOOR DRYBULB TEMPERATURE AT HOUR J, F
40     % DBA DAILY AVERAGE OUTSIDE DRYBULB TEMPERATURE, F
41     % DRIN DESIGN INDOOR DRYBULB TEMPERATURE, F
42     % DDM DRYBULB MEAN, F
43     % DRMAX DESIGN OUTDOOR MAXIMUM DRYBULB TEMPERATURE, F
44     % DRMWT DESIGN WINTER OUTDOOR DRYBULB TEMPERATURE, F
45     % DRNRS(I) FRACTION OF RANGE TO USE FOR DESIGN PROFILE
46     % AT HOUR J
47     % DP OUTDOOR DEW POINT, F
48     % DPIP INDOOR DEW POINT, F
49     % DPTM DESIGN INDOOR DEW POINT, F
50     % DR(L) RESPONSE FACTOR COMMON RATIO FOR CONSTRUCTION L
51     % (SAME AS CR(L))

```

| | | | |
|-----|---|----------------|---|
| 52 | % | DST | DAYLIGHT SAVING TIME INDICATOR |
| 53 | % | ELAPS | DAYS ELAPSED SINCE JANUARY 1 |
| 54 | % | G(IV,VI) | RADIATION CONFIGURATION FACTORS FOR |
| 55 | % | | RADIATION FROM SURFACE VI TO SURFACE IV |
| 56 | % | H(I) | EXTERIOR SURFACE HEAT TRANSFER COEFFICIENT |
| 57 | % | | FOR SURFACE I, BTU/HR.FT ² .F |
| 58 | % | HI(I) | INTERIOR SURFACE CONVECTION HEAT TRANSFER |
| 59 | % | | COEFFICIENT, BTU/HR.FT ² .F |
| 60 | % | HIND | INDOOR ENTHALPY FOR DESIGN CONDITIONS, BTU/LB |
| 61 | % | HLDAY | DAILY TOTAL ENERGY CONSUMPTION FOR HEATING FOR A |
| 62 | % | | GROUP (NORM OF THEM) OF ROOMS OF THE SAME |
| 63 | % | | CONFIGURATION, BTU |
| 64 | % | HLDSUM | RUNNING TOTAL ENERGY CONSUMPTION FOR HEATING OF |
| 65 | % | | ALL THE ROOMS IN A BUILDING, BTU |
| 66 | % | HOUT | OUTDOOR ENTHALPY FOR DESIGN CONDITIONS, BTU/LB |
| 67 | % | HR | INNER SURFACE RADIATIVE HEAT TRANSFER COEFFICIENT |
| 68 | % | | (=4.*(535.**3)*SIGMA) |
| 69 | % | HT | CEILING HEIGHT, FT |
| 70 | % | IHT(I) | HEAT TRANSFER INDEX |
| 71 | % | | =-1 FOR GLASS SURFACE |
| 72 | % | | = 0 OPAQUE |
| 73 | % | | = 1 OTHERWISE |
| 74 | % | IMAX | HOUR OF DAY FOR MAXIMUM COOLING LOAD |
| 75 | % | INCLUD | =0 INCLUDE ROOM IN SUMMARY |
| 76 | % | | =1 OTHERWISE |
| 77 | % | IRF(I) | RESPONSE FACTOR INDEX FOR SURFACE I |
| 78 | % | IROT | DEGREES OF ROTATION |
| 79 | % | ISKIP | = 1 SKIP RESPONSE FACTOR CALCULATION |
| 80 | % | | AND BUILDING DATA INPUT |
| 81 | % | | = 0 OTHERWISE |
| 82 | % | ITK AND ITHST | INDICES FOR ROOM TEMPERATURE COMPUTATION |
| 83 | % | ITK=0, ITHST=1 | ROOM TEMP PRESCRIBED, EITHER CONSTANT |
| 84 | % | | OR WITH NIGHT TIME SET-BACK |
| 85 | % | ITK=1, ITHST=0 | ROOM TEMP NOT BEING CONTROLLED, NO A/C. |
| 86 | % | ITK=1, ITHST=1 | ROOM TEMP FLOAT WITHIN PRESCRIBED UPPER |
| 87 | % | | AND LOWER LIMITS, NO A/C WHEN WITHIN |
| 88 | % | | THE LIMITS. |
| 89 | % | ITK=0, ITHST=0 | EQUIPMENT CAPACITY PRESCRIBED, ROOM TEMP |
| 90 | % | | FLOAT WITHIN PRESCRIBED UPPER AND LOWER |
| 91 | % | | LIMITS, AND WHEN EQUIPMENT CAPACITY IS |
| 92 | % | | EXCEEDED. |
| 93 | % | ITYPE(I) | TYPE OF SURFACE I |
| 94 | % | | = 1 ROOF |
| 95 | % | | = 2 EXPOSED WALL |
| 96 | % | | = 3 WINDOW |
| 97 | % | | = 4 DOOR |
| 98 | % | | = 5 GROUND HEAT TRANSFER SURFACE |
| 99 | % | | = 6 INTERNAL MASS, FURNISHINGS, PARTY WALLS, |
| 100 | % | | PARTITION WALLS, AND FLOOR/CEILINGS |
| 101 | % | | = 7 OPEN PASSAGES |

| | | | |
|-----|---|-------------|--|
| 102 | % | | = 8 EXPOSED FLOOR (EXPOSED UNDERSIDE) |
| 103 | % | LAT | LATITUDE, DEGREES |
| 104 | % | LONG | LONGITUDE, DEGREES |
| 105 | % | LPYR | LEAP YEAR INDICATOR |
| 106 | % | MONTH | MONTH OF YEAR |
| 107 | % | MR(I) | NUMBER OF RESPONSE FACTOR TERMS GENER- |
| 108 | % | | ATED BY RESPTK FOR CONSTRUCTION L |
| 109 | % | | SAME AS NR(I) |
| 110 | % | NAMFRD | NAME OF ROOM |
| 111 | % | NE | NUMBER OF SURFACES IN EAST WALL |
| 112 | % | NEXP | TOTAL NUMBER OF SURFACES IN ROOM |
| 113 | % | | = 2+NS+NW+NN+NE |
| 114 | % | NMAX | HR OF THE DAY WHEN QLMAX OCCURS |
| 115 | % | NN | NUMBER OF SURFACES IN NORTH WALL |
| 116 | % | NOFID | NUMBER OF FLOORS |
| 117 | % | NORM | NO. OF ROOMS HAVING THE SAME "DATA |
| 118 | % | NR(I) | NUMBER OF RESPONSE FACTOR TERMS CALCU- |
| 119 | % | | LATED BY RESPTK FOR CONSTRUCTION L |
| 120 | % | NS | NUMBER OF SURFACES IN SOUTH WALL |
| 121 | % | NW | NUMBER OF SURFACES IN WEST WALL |
| 122 | % | PR | BAROMETRIC PRESSURE |
| 123 | % | | = 29.921 INCHES OF MERCURY |
| 124 | % | PI | = 3.1415... |
| 125 | % | PV | VAPOR PRESSURE, INCHES OF MERCURY |
| 126 | % | QCH | MAXIMUM NUMBER OF OCCUPANTS |
| 127 | % | QDES(I) | HEAT GAIN OF SURFACE I AT HOUR I MAX, BTU/HR |
| 128 | % | QDESIN(I,J) | HEAT GAIN OF SURFACE I AT HOUR J, |
| 129 | % | | BTU/HR |
| 130 | % | QEOPD | EQUIPMENT MAXIMUM HEAT LOAD, BTU/HR |
| 131 | % | QEQPX | MAXIMUM EQUIPMENT LOAD, WATTS/FT2 |
| 132 | % | QEQIP(J) | EQUIPMENT LOAD AT HOUR J, BTU/HR |
| 133 | % | QEQIX(J) | EQUIPMENT USE SCHEDULE |
| 134 | % | QGLAS(I,J) | HEAT GAIN OF GLASS FOR I AT HOUR J, |
| 135 | % | | BTU/HR |
| 136 | % | QGX(I) | HEAT TRANSMISSION OF GLASS FOR SURFACE |
| 137 | % | | I AT HOUR I MAX, BTU/HR |
| 138 | % | QI(I) | INSIDE SURFACE HEAT FLUX OF SURFACE I, |
| 139 | % | | BTU/HR,FT2 |
| 140 | % | QISAVE(J,I) | INSIDE SURFACE HEAT FLUX OF SURFACE |
| 141 | % | | I AT HOUR J, BTU/HR,FT2 |
| 142 | % | QLDS | SUM OF LATENT AND SENSIBLE LOAD AT HOUR |
| 143 | % | | J, BTU/HR |
| 144 | % | QLITE(J) | LIGHT LOAD AT HOUR J, BTU/HR |
| 145 | % | QLITO | MAXIMUM LIGHT LOAD, BTU/HR |
| 146 | % | QLITX(J) | LIGHT USE SCHEDULE |
| 147 | % | QLITY | MAXIMUM LIGHTING LOAD, WATTS/FT2 |
| 148 | % | QLMAX | ABSOLUTE VALUE OF THE MAX COOLING (OR |
| 149 | % | | HEATING) LOAD OF THE DAY, BTU/HR |
| 150 | % | QLL(J) | LATENT HEAT LOAD AT HOUR J, BTU/HR |
| 151 | % | QLS(J) | SENSIBLE HEAT LOAD AT HOUR J, BTU/HR |

| | | | |
|-----|---|------------|--|
| 152 | % | QO(T) | OUTSIDE SURFACE HEAT FLUX OF SURFACE I, BTU/HR, FT ² |
| 153 | % | | |
| 154 | % | QOCP5(J) | OCCUPANT LOAD AT HOUR J, BTU/HR |
| 155 | % | QOCNP(J) | OCCUPANT SCHEDULE |
| 156 | % | QPFOP(L(J) | PEOPLE LATENT LOAD AT HOUR J, BTU/HR |
| 157 | % | QPLY | MAX OCCUPANT LATENT LOAD, BTU/HR, PERSON |
| 158 | % | QPSX | MAX OCCUPANT SENSIBLE LOAD, BTU/HR, PERSON |
| 159 | % | QSAVE(M,J) | HEAT GAINS AND LOADS AT HOUR J, BTU/HR |
| 160 | % | | M = 1 TIME, HR |
| 161 | % | | M = 2 SENSIBLE HEAT GAIN, BTU/HR |
| 162 | % | | M = 3 LATENT HEAT GAIN, BTU/HR |
| 163 | % | | M = 4 SENSIBLE LOAD, BTU/HR |
| 164 | % | | M = 5 TOTAL LOAD, BTU/HR |
| 165 | % | QSKY(I,J) | HEAT RADIATED TO SKY BY SURFACE I T HOUR J, BTU/HR, FT ² |
| 166 | % | | |
| 167 | % | QSUMT | SUM OF TOTAL HEAT GAINS FOR 24 HOURS, BTU/HR |
| 168 | % | | |
| 169 | % | QSUN(I,J) | INCIDENT SOLAR RADIATION FOR SURFACE I AT HOUR J, BTU/HR, FT ² |
| 170 | % | | |
| 171 | % | QTL(J) | LATENT HEAT GAIN FROM INFILTRATION AT HOUR J, BTU/HR |
| 172 | % | | |
| 173 | % | QWINT | HEAT LOSS IN WINTER, BTU/HR |
| 174 | % | RANGE | DAILY RANGE OF OUTDOOR DRYBULB, F |
| 175 | % | RHIN | DESIGN INDOOR RELATIVE HUMIDITY |
| 176 | % | RHOUT | DESIGN OUTDOOR RELATIVE HUMIDITY |
| 177 | % | ROOMNO | ROOM NUMBER |
| 178 | % | S | INFORMATION ARRAY REQUIRED BY SUBROU- TINE SUN AND GLASS |
| 179 | % | | |
| 180 | % | SHADE(J) | SHADING COEFFICIENT FOR SURFACE I |
| 181 | % | SIGMA | = 0.1714E-8 |
| 182 | % | SITFLD(J) | OVERALL COOLING LOAD AT HOUR J, BTU/HR |
| 183 | % | SITFOL(J) | OVERALL LATENT HEAT GAIN AT HOUR J, BTU/HR |
| 184 | % | | |
| 185 | % | SITFOS(J) | OVERALL SENSIBLE HEAT GAIN AT HOUR J, BTU/HR |
| 186 | % | | |
| 187 | % | SITETH(J) | OVERALL TOTAL HEAT GAIN AT HOUR J, BTU/HR |
| 188 | % | | |
| 189 | % | SITMAX | OVERALL MAXIMUM HEAT GAIN, BTU/HR |
| 190 | % | SOTHX | OVERALL HEAT GAIN AT HOUR IMAX, BTU/HR |
| 191 | % | SQLD | TOTAL COOLING LOAD, BTU/HR |
| 192 | % | SQWJNT | OVERALL TOTAL HEAT LOSS, BTU/HR |
| 193 | % | TA | ROOM AIR TEMPERATURE, F |
| 194 | % | TASAVE(J) | ROOM AIR TEMPERATURE AT HOUR J, F |
| 195 | % | TCLLD | DAILY RUNNING TOTAL ENERGY CONSUMPTION FOR COOLING FOR A GROUP (NORM OF THEM) OF ROOMS HAVING THE SAME CONFIGURATION, BTU |
| 196 | % | | |
| 197 | % | | |
| 198 | % | | |
| 199 | % | TG | DESIGN SUMMER GROUND TEMPERATURE, F |
| 200 | % | TGW | DESIGN WINTER GROUND TEMPERATURE, F |
| 201 | % | THTLD | DAILY RUNNING TOTAL ENERGY CONSUMPTION |

| | | | |
|-----|---|-------------|--|
| 202 | % | | FOR HEATING FOR A GRUOP (NORM OF THEM) |
| 203 | % | | OF ROOMS HAVING THE SAME CONFIGURATION, |
| 204 | % | | BTU |
| 205 | % | TI(I) | INSIDE SURFACE TEMPERATURE RELATIVE TO |
| 206 | % | | THE REFERENCE TEMPERATURE AT HOUR J |
| 207 | % | TIF(J) | INSIDE SURFACE TEMPERATURE AT HOUR J, F |
| 208 | % | TIFSAV(J,I) | INSIDE SURFACE TEMPERATURE OF SUR- |
| 209 | % | | FACE I AT HOUR J, F |
| 210 | % | TIM | INDOOR DESIGN MEAN (REFERENCE TEMPERA- |
| 211 | % | | TURE), F |
| 212 | % | TIO | INDOOR DESIGN TEMPERATURE, F |
| 213 | % | TIS(I,J) | INSIDE SURFACE TEMPERATURE RELATIVE TO |
| 214 | % | | THE REFERENCE TEMPERATURE OF SURFACE I |
| 215 | % | | AT HOUR J, F |
| 216 | % | TIX(J) | INDOOR DESIGN DRYBULB TEMPERATURE AT |
| 217 | % | | HOUR J, F |
| 218 | % | TNEW(I) | UPDATED OUTSIDE SURFACE TEMPERATURE OF |
| 219 | % | | SURFACE I AT EVERY TIME INCEMENT, F |
| 220 | % | TNUSAV(J,I) | UPDATED OUTSIDE SURFACE TEMPERATRE |
| 221 | % | | OF SURFACE I AT HOUR J, F |
| 222 | % | TOS(I,J) | OUTSIDE SURFACE TEMPERATURE RELATIVE TO |
| 223 | % | | REFERENCE TEMPERATURE OF SURFACE I AT |
| 224 | % | | HOUR J, F |
| 225 | % | TOTHTX | TOTAL COOLING LOAD FOR A ROOM, BTU/HR |
| 226 | % | TOY(J) | ARRAY USED FOR TEMPORARY STORAGE OF |
| 227 | % | | VALUES WHILE ADVANCING TEMPERATURE AS |
| 228 | % | | REQUIRED BY RESPONSE FACTOR METHOD |
| 229 | % | TSAVE | MAXIMUM TOTAL COOLING LOAD, BTU/HR |
| 230 | % | TSITHT | TOTAL OVERALL HEAT GAIN FOR 24 HOURS, |
| 231 | % | | BTU/HR |
| 232 | % | TV | TEMPERATURE OF VENTILATING AIR, F |
| 233 | % | TZN | TIME ZONE NUMBER |
| 234 | % | U(I) | OVERALL HEAT TRANSFER COEFFICIENT FOR |
| 235 | % | | SURFACE I |
| 236 | % | UCFLNG | OVERALL HEAT TRANSFER COEFFICIENT OF |
| 237 | % | | THE CEILING BETWEEN THE ATTIC AIR AND |
| 238 | % | | THE ROOM AIR BELOW |
| 239 | % | UENDW | OVERALL HEAT TRANSFER COEFFICIENT OF |
| 240 | % | | THE ATTIC ENDWALL |
| 241 | % | UG | GROUND HEAT TRANSFER COEFFICIENT |
| 242 | % | UGLAS | WINTER GLASS HEAT TRANSFER COEFFICIENT |
| 243 | % | UT(I) | U VALUE WITHOUT SURFACE RESISTANCES |
| 244 | % | VIN | INDOOR AIR SPECIFIC VOLUME, FT ³ /LB |
| 245 | % | VOUT | OUTDOOR AIR SPECIFIC VOLUME, FT ³ /LB |
| 246 | % | VT(L) | SAME AS UT(I) |
| 247 | % | WA | OUTDOOR AIR HUMIDITY RATIO, LB OF H ₂ O |
| 248 | % | | VAPOR PER LB OF DRY AIR (= wOUT) |
| 249 | % | WAZ(I) | WALL AZIMUTH ANGLE MEASURED CLOCKWISE |
| 250 | % | | FROM SOUTH, DEGREES |
| 251 | % | WBID | DESIGN INDOOR WETBULB TEMPERATURE, F |

```

252 % WJMAX DESIGN OUTDOOR WETHULB TEMPERATURE, F
253 % WBSAVE(J) INDOOR WETHULB TEMPERATURE AT HOUR J, F
254 % WID DESIGN INDOOR HUMIDITY RATIO, LB OF H2O
255 % VAPOR/LB OF DRY AIR
256 % WIN INDOOR HUMIDITY RATIO, LB H2O/LB DRY AIR
257 % WOUT DESIGN OUTDOOR HUMIDITY RATIO, LB H2O
258 % VAPOR/LB DRY AIR
259 % WROT DEGREES OF ROTATION FOR ROOM
260 % WT WALL TILT ANGLE (= 90. DEGREES WHEN
261 % VERTICAL WALL)
262 % WV VENTILATION AIR HUMIDITY RATIO, LB H2O
263 % VAPOR/LB DRY AIR
264 % X(L,N) RESPONSE FACTORS FOR CONSTRUCTION L
265 % XX(N,L) TRANSPOSE OF ARRAY X
266 % Y(L,N) RESPONSE FACTORS FOR CONSTRUCTION L
267 % YY(N,L) TRANSPOSE OF ARRAY Y
268 % Z(L,N) RESPONSE FACTORS FOR CONSTRUCTION L
269 % ZBLDG INPUT ARRAY FOR BUILDING AND EXTERNAL DATA
270 % ZROOM INPUT ARRAY FOR ROOM DATA
271 % ZZ(N,L) TRANSPOSE OF ARRAY Z
272 %
273 %
274 COMMON /CC/ X(10,100),Y(10,100),Z(10,100),I1YPE(30),IHT(30),IRF(30%
275 ),ARSP(30),U(30),H(30),HI(30),A(30),UT(30),TUS(30,48),TIS(30,48),G%
276 (30,30),TOY(48),DB(24),OLIX(24,3),OEUQX(24,3),OOCUP(24,3),OOCPS(2%
277 % OLITE(24),OEUQ(24),OI(30),CR(30),BR(30),UGLAS(30,24),IHST,UFN%
278 DW,AW(30),SHADE(30),RMOBS(24),RMDRW(24),SHD(30),UCELNG
279 DIMENSION XX(100,10),YY(100,10),ZZ(100,10),TNEW(100),TI(48),XDUM(1%
280 % YDUM(100),ZDUM(100),TDUM(100),OU(30),TIF(30),OSUN(30,24),OSKY(%
281 % 24),NAMERM(9),NAMEBD(9),VT(10),DR(10),MR(10)
282 DIMENSION DPT(24),WHT(24),PBI(24),WST(24),IC(24),NTOC(24)
283 DIMENSION SALT(24),IEDAY(12)/15,46,74,105,135,166,196,227,258,288,%
284 319,349/
285 DIMENSION CALDR(24),CALRH(24),PGLAS(30,24),PSUN(30,24),FATLIC(100)%
286 % QLS(24),QLL(24),ZBLDG(15),ZROOM(12),UW(30)
287 DIMENSION HEATG(2),HEATX(2),HEATIS(2),HLCG(2),HLCX(2),HLCIS(2)
288 DIMENSION DHPF(24)/.87,.92,.96,.99,1.00,.98,.93,.84,.71,.56,.39 %
289 %.23,.11,.03,0.0,.03,.10,.21,.34,.47,.58,.68,.76,.82/
290 COMMON/SHDW/SHAW(30,I5)
291 DIMENSION SHDX(20),SHDF(30,24),AIRLK(24),OSOL(24)
292 DIMENSION V(15),PLAT(24),AIRLAT(24),HALD(24),BASEL(24)
293 INTEGER DSTX,DSTY,RUNID,RUNTY,ASHRAE
294 REAL LAT,LONG,NOFLP
295 INTEGER CITY,YEAR,TAPF?
296 LOGICAL LL1,LL2
297 COMMON /SOL/ LAT,LONG,TZN,WAZ,WT,CN,DSX,LPYR,S(35)
298 COMMON NSKP
299 PI=3.1415927
300 WRITE(6,I051)
301 WRITE(6,I052)

```



```

302          WRITE(6,1053)
303          WRITE(6,1054)
304          WRITE(6,998)
305 998      FORMAT(//' RUNID,RUNTYP,ASHRAE,IDETAL,METHOD,NHAY'/%
306          ' RUNID.....IDENTIFICATION OF THE RUN'/%
307          '          1 NEED RESPONSE FACTOR DATA'/%
308          '          2 SKIP RESPONSE FACTOR DATA'/%
309          ' RUNTYP.....TYPE OF RUN'/%
310          '          1 ENERGY CALCULATION ..NEEDS WEATHER TAPE'/%
311          '          2 DESIGN LOAD CALCULATION'/%
312          '          3 DESIGN AND ENERGY LOAD CALCULATIONS'/%
313          ' ASHRAE.....0   USE RMTMP'/%
314          '          1   USE ASHRAE WEIGHTING FACTORS'/%
315          ' IDETAL.....0   NO DETAILED OUTPUT'/%
316          '          1   DETAILED OUTPUT'/%
317          ' METHOD.....0   REGULAR TREATMENT FOR THE ROOM'/%
318          '          1   SPECIAL TREATMENT OF THE ROOM'/%
318.1      ' NHAY.....0   STANDARD SIMULATION'/%
318.2      '          1   WFT ROOF SIMULATION')
319      READ(5,*) RUNID,RUNTYP,ASHRAE,IDETAL,METHOD,NHAY
320      CALL OBEY('EQUATE 8 RFTR',4)
321      IF(RUNID.EQ.1) CALL OBEY('SWITCH IN#:NBSBL1',5)
322      IF(RUNID.EQ.2) CALL OBEY('SWITCH IN#:NBSBL2',5)
323      CALL OBEY('EQUATE TAPE2 OUTDAT',5)
324      READ(5,911) NAMEHD
325      WRITE(6,910) NAMEHD
326      * READ 24 HOUR PROFILES FOR LIGHTING,EQUIPMENT AND OCCUPANCY
327      J3=3
328      DO 10 J=1,J3
329          IF(J.EQ.1) WRITE(6,901)
330 901      FORMAT(' LIGHTING SCHEDULE FOR WEEKDAYS')
331          IF(J.EQ.2) WRITE(6,904)
332 904      FORMAT(' LIGHTING SCHEDULE FOR WEEKEND')
333          IF(J.EQ.3) WRITE(6,907)
334 907      FORMAT(' LIGHTING SCHEDULE FOR THE VACATION PERIOD')
335      READ(5,*)(QLITX(I,J),I=1,24)
336          IF(J.EQ.1) WRITE(6,902)
337 902      FORMAT(' EQUIPMENT USAGE SCHEDULE FOR WEEKDAYS')
338          IF(J.EQ.2) WRITE(6,905)
339 905      FORMAT(' EQUIPMENT SCHEDULE FOR WEEKENDS')
340          IF(J.EQ.3) WRITE(6,908)
341 908      FORMAT(' EQUIPMENT USAGE SCHEDULE FOR THE VACATION PERIOD')
342      READ(5,*)(QEQUX(I,J),I=1,24)
343          IF(J.EQ.1) WRITE(6,903)
344 903      FORMAT(' OCCUPANCY SCHEDULE FOR WEEKDAYS')
345          IF(J.EQ.2) WRITE(6,906)
346 906      FORMAT(' OCCUPANCY SCHEDULE FOR WEEKEND')
347          IF(J.EQ.3) WRITE(6,909)
348 909      FORMAT(' OCCUPANCY SCHEDULE FOR THE VACATION PERIOD')
349      READ(5,*)(QOCCUP(I,J),I=1,24)

```

```

350      10  CONTINUE
351      IF (PUNTY.PGT.2) RUNTYP=2
352      WRITE(6,914)
353      914  FORMAT(' THERMOSTAT SETTING FOR THE COOLING SEASON')
354      READ(5,*) RMDHS
355      WRITE(6,915)
356      915  FORMAT(' THERMOSTAT SETTING FOR THE HEATING SEASON')
357      READ(5,*) RMDRW
358      WRITE(6,916)
359      916  FORMAT(' RMDRW,RMDHS,RHW,RHS')
360      READ(5,*) RMDRW,RMDHS,RHW,RHS
361      SIGMA=0.1714E-R
362      HR=4.*0.9*SIGMA*(530.**3)
363      WRITE(6,881)
364      881  FORMAT(' DATA SHEET NO 1:NDAY,NSKIP,TAPE2')
365      READ(5,*)NDAY,NSKIP,TAPE2
366      WRITE(6,882)
367      882  FORMAT(' DATA SHEET NO 2 & 3 :MONTH,DAY,ELAPS,DRMAX,RANGE,WBMAX,6
368  DRMWT,TGS,TGW,UG,LONG,LAT,TZN,ZLF,RHOW')
369      READ(5,*)ZBLDG
370      CLDSUM=0.
371      HLDSUM=0.
372      DO 750 I,J,K,L,M,N=1,1 0
373      WRITE(6,883)
374      883  FORMAT(' DATA SHEET NO 4: NAME OF THE ROOM')
375      READ(5,910) NAMERM
376      %    IF TAPE2 IS NOT BLANK B TAPE SHOULD BE ASSIGNED
377      IF (NAMERM(1).EQ.' ') STOP
378      WRITE(6,884)
379      884  FORMAT(' DATA SHEET NO 5:IRDT,ISKIP,(INCLUDE)')
380      READ(5,*) IRDT,ISKIP,INCLUDE
381      %    IF ISKIP .NE. 0, RESPONSE FACTOR CALCULATION IS SKIPPED
382      %    SO NO WALL DATA IS NEEDED
383      IF (ISKIP.NE.0) GO TO 30
384      DO 20 I=1,10
385      DO 20 J=1,100
386      X(I,J)=0.
387      Y(I,J)=0.
388      20  Z(I,J)=0.
389      IF (PUNTD.EQ.1) GO TO 21
390      READ(8) X,Y,Z,MR,DR,VT
391      GO TO 22
392      %    THIS RESPONSE FACTOR ROUTINE REQUIRES MANY CONSTRUCTION DATA
393      %    PLEASE REFER TO THE INPUT INSTRUCTIONS
394      21  CONTINUE
395      IF (TDFTAL.EQ.0) CALL OBEY('SWITCH OFF:RESTAB',5)
396      CALL RFSEFX (X,Y,Z,XX,YY,ZZ,MR,DR,VT,10)
397      IF (TDFTAL.EQ.0) CALL OBEY('SWITCH OFF:CLOSE',5)
398      WRITE(8) X,Y,Z,MR,DR,VT
399      END FILE 8

```

```

400      22      PR=29.921
401      30      IF (JROT.NE.0) GO TO 40
402          WROT=0.
403          WRITE (6,891)
404      891      FORMAT (' DATA SHEET NO 8: ROOMNO,QLITY,GEQPY,QCU,FLCG,FRAS,TS,CFMS,ARCHGS,ARCHGW,ARCHGM,ZNORM')
405          READ (5,*) ZROOM
406          WRITE (6,892)
407      892      FORMAT (' DATA SHEET NO.9: IW,IL,ISTART,ILEAVE')
408          READ (5,*) IW,IL,ISTART,ILEAVE
408.1      WRITE (6,893)
408.2      893      FORMAT (' DATA SHEET NO 10: TUL,TLL,QCMAX,QHMAX,DBVMAX,DBVMIN')
409          READ (5,*) TUL,TLL,QCMAX,QHMAX,DBVMAX,DBVMIN
409.1      WRITE (6,894)
409.2      894      FORMAT (' DATA SHEET NO 11: ITHST,ITK')
410          READ (5,*) ITHST,ITK
411          CALL ROOMX (NEXP,NS,NW,NN,NE,HT)
412          ROOMNO=ZROOM(1)
413          MONTH=ZBLDG(1)
414          AG=A(NEXP)
415          NOFIR=1
416          QCU=ZROOM(4)
417          LAT=ZBLOG(12)
418          LONG=ZBLOG(11)
419          TZN=ZBLDG(13)
420          DAYSKP=NSKIP
421          QLITY=ZROOM(2)
422          GEQPY=ZROOM(3)
423          CFMV=ZROOM(8)
424          WRMAX=ZBLOG(6)
425          CFMS=CFMV
426          FLCG=ZROOM(5)
427          TGS=ZBLDG(8)
428          TGW=ZBLDG(9)
429          LDAY=ZBLDG(2)
430          YEAP=2000
431          DBWT=ZBLOG(7)
432          ORMAX=ZBLDG(4)
433          RHOW=ZBLDG(15)
434          ZLF=ZBLDG(14)
435          DRIN=RMDRW(12)
436          RHIN=RHW
437          IF (PUNTYE.EQ.2) CALL PSYI (DRMAX,WRMAX,PB,DPMAX,PV,WA,HA,VA,RHO)
438          UG=ZBLDG(10)
439          TV=ZROOM(7)
440          FRAC=ZROOM(6)
441          ZNORM=ZROOM(12)
442          ARCHGW=ZROOM(10)
443          CFMWT=AG*HT*ARCHGW/60.+CFMV
444          ARCHGM=ZROOM(11)
445          CFMTN=AG*HT*ARCHGM/60.

```

```

446          CONST=ARCHGW/0.695
447          %      THESE AIR CHANGE VALUES ARE FOR THE ATTIC VENTILATION
448          %      ROOM AIR CHANGE VALUES WILL BE DETERMINED AS A FUNCTION OF
449          %      WIND SPEED AND TEMPERATURE DIFFERENTIAL
450          40      CONTINUE
451          IF (IDETAL.EQ.0) GO TO 50
451.1        WRITE (6,874)
452          WRITE (6,790)
453          WRITE (6,800) ROOMNO,HT,AG,NOFLR,QCU,ZROOM(9),ZROOM(10)
454          WRITE (6,1010)
455          50      CONTINUE
456          S(1)=LAT
457          S(2)=LONG
458          S(3)=TZN
459          IF (IDETAL.EQ.0) GO TO 60
460          WRITE (6,810)
461          WRITE (6,800) LAT,LONG,TZN,ZNORM
462          WRITE (6,1010)
463          WRITE (6,820)
464          RHJN=RHS
465          WRITE (6,800) OLITY,QFOPX,CFMV,DRIN,IG,IV,RHIN
466          WRITE (6,1010)
467          WRITE (6,840) NEXP,ITK,ITHST
467.1        WRITE (6,874)
468          60      CONTINUE
469          IF (IROT.NE.0) GO TO 61
470          WRITE (6,841)
471          841     FORMAT(' DATA SHEET NO 15: UENDW,UCELNG,AENDW,ATCHT,AIRCHG,AIRNT')
472          READ(5,*) UENDW,UCELNG,AENDW,ATCHT,AIRCHG,AIRNT
473          WRITE (6,842)
474          842     FORMAT(' DATA SHEET NO 16: IEXTSD,IEXMS,IEXMF,NTVNT,NVENT'//)
475          READ(5,*) IEXTSD,IEXMS,IEXMF,NTVNT,NVENT
476          CFMNT=NTVNT*AG*HT/60.
477          61      CONTINUE
478          IF (IDETAL.EQ.0) GO TO 70
479          WRITE (6,1010)
480          WRITE (6,830)
481          WRITE (6,800) UENDW,UCELNG,AENDW,ATCHT
482          70      CONTINUE
483          IF (IROT.NE.0) GO TO 160
484          SUM=0.
485          DO 151 I=1,NEXP
486          K=IRF(I)
487          IF (Y(K,1).GT.1.) IRF(I)=10
488          NR(I)=MR(K)
488.1        IF (IRF(I).EQ.10) NR(I)=1
489          UT(I)=VT(K)
490          CR(I)=DR(K)
491          IF (NR(I).EQ.0) NR(I)=1
492          IF (NR(I).GT.48) NR(I)=48

```

```

493         IF (ITYPE(I).EQ.3) ABSP(I)=0.
494         IF (ITYPE(I).EQ.5) ABSP(I)=0.
495         IF (ITYPE(I).GE.6) ABSP(I)=0.
496         IHT(I)=1
497         IF (ITYPE(I).EQ.3) IHT(I)=-1
498         H(I)=6.0
499         HI(I)=1.46-HR
500         IF (ITYPE(I).GE.5) H(I)=0.
501         IF (ITYPE(I).EQ.1) HI(I)=1.630-HR
502         IF (ITYPE(I).EQ.5) HI(I)=1.080-HR
503         IF (ITYPE(I).EQ.7) U(I)=500.
504         IF (ITYPE(I).EQ.8) H(I)=1.46
504.1       IF (IRF(I).NE.10) U(I)=0.
505         IF (U(I)) 80,80,90
506         80  RU=1./UT(I)+1./(HI(I)+HR)
507         IF (ITYPE(I).LT.5.OR.ITYPE(I).EQ.8) RU=RU+1./H(I)
508         U(I)=1./RU
509         90  CONTINUE
510         IF (X(K,2)) 140,100,140
511         100 IF (H(I)) 110,120,110
512         110 R=1./U(I)-1./H(I)
513         GO TO 130
514         120 R=1./U(I)
515         130 UT(I)=1./(R-1./(HI(I)+HR))
516         IF (UT(I).LE.0.) UT(I)=28.0
517         IF (ITYPE(I).EQ.7) UT(I)=500.
518         140 CONTINUE
519         IF (UCFLNG) 150,150,141
519.1       141 IF (ITYPE(I).NE.1) GO TO 150
520         RTA=1./UCFLNG-1./(HI(I)+HR)
521         UT(I)=1./RTA
522         150 CONTINUE
522.1       UW(I)=U(I)
523         IF (ITYPE(I).GT.4) GO TO 151
524         SUM=SUM+A(I)*U(I)
525         151 CONTINUE
526         ZK=SUM/ZLF
527         FC=1.-0.02*ZK
528         160 IF (IROT.EQ.0) GO TO 180
529         WROT=IROT
530         DO 170 I=1,NEXP
531         AZW(I)=AZW(I)+WROT
532         IF (AZW(I).LT.-180.) AZW(I)=AZW(I)+360.
533         170 IF (AZW(I).GT.180.) AZW(I)=AZW(I)-360.
533.1       DO 181 I=1,NEXP
533.2         DO 181 J=1,NEXP
533.3       181  G(I,J)=G(I,J)/HR
534         180 CONTINUE
535         IF (IDETAL.EQ.0) GO TO 220
536         WRITE (6,950)

```

```

537          DO 190 I=1,NEXP
538          WRITE (6,920) I,ITYPE(I),IHT(I),IRF(I),ABSP(I),U(I),H(I),A(I),AZW(%
539          I),SHADE(I),UT(I),HI(I)
540          190  CONTINUE
541          WRITE (6,960)
542          DO 200 I=1,NEXP
543          200  WRITE(6,800) (SHAW(I,J),J=1,15)
544          IF (ASHRAE.EQ.1) GO TO 235
545          WRITE (6,970)
546          WRITE (6,980)
547          DO 210 I=1,NEXP
548          WRITE (6,990) I,(G(I,J),J=1,NEXP)
549          210  CONTINUE
550          220  IF (RUNTYP.EQ.2) CALL WINTER(A,UW,ITYPE,NEXP,CFMWT,DBIN,DBWT*,
551          *UG,TGW,RHW,RHOW)
552          DO 230 I=1,NEXP
553          DO 230 J=1,NEXP
554          230  G(I,J)=HP*G(I,J)
555          235  TIM=TUL
556          QLITO=QLITY*AG*3.413*NOFLR
557          QEQPO=QEQPX*AG*3.413*NOFLR
558          DO 240 I=1,NEXP
559          QO(T)=0.
560          QI(T)=0.
561          240  CONTINUE
561.1        QRFQ=0.
561.2        QRFI=0.
562          *   DBM=TIM= REFERENCE TEMPERATURE
563          TA=TIM
564          MOT=0
565          TCLID=0.
566          THTI D=0.
566.1        IF (TJKLMN.GT.1) GO TO 243
567          CALL OREY ('SWITCH INF:CLOSE',5)
567.1        243  CONTINUE
568          NEND=DAYSKEP+NDAY
569          IF (RUNTYP.NE.2) GO TO 241
570          NEND=7
571          DO 242 J=1,24
572          DB(J)=ZBLDG(4)-ZBLDG(5)*DRPF(J)
573          DPT(J)=DPMAX
574          WST(J)=0.
575          PBT(J)=29.921
576          TC(J)=0.
577          NTOC(J)=0
578          242  CONTINUE
579          241  DO 740 ND=1,NEND
580          NSKP=ND-DAYSKEP
581          IF (RUNTYP.EQ.2) GO TO 261
582          READ(7) DB,DPT,WBT,WST,PBT,TC,NTOC,LDAY,YEAR,MONTH,CITY

```



```

583      N=ND-DAYSKP
584      IF (N.LT.1) GO TO 740
585      INDAY=DAYSKP+N
586      IF (IDETAL.EQ.0) GO TO 250
587      WRITE (6,860) N,INDAY,YEAR,MONTH,LDAY
588      WRITE (6,850) NAMERM
589      250  CONTINUE
590      KDAY=WKDAY(YEAR,MONTH,LDAY)
591      CALL HOLDAY (YEAR,MONTH,LDAY,KDAY,IHOL)
592      CALL DST (YEAR,MONTH,LDAY,DSTX,DSTY)
593      IDST=1
594      IF (MONTH.LT.4) IDST=0
595      IF (MONTH.GT.10) IDST=0
596      IF (MONTH.NE.4.OR.MONTH.NE.10) GO TO 260
597      IF (MONTH.EQ.4.AND.LDAY.LT.DSTX) IDST=0
598      IF (MONTH.EQ.10.AND.LDAY.GT.DSTY) IDST=0
599      260  DSX=IDST
600      JJ=1
601      IF (KDAY.EQ.7.OR.KDAY.EQ.1) JJ=2
602      IF (IHOL.EQ.1) JJ=2
603      261  IF (RUNTYP.EQ.2) JJ=1
604      DO 270 J=1,24
605      QLITF(J)=QLITO*QLITX(J,JJ)
606      QEQIP(J)=QENPO*QEQIX(J,JJ)
607      270  CONTINUE
608      IF (MONTH.EQ.MOT) GO TO 390
609      TG=TGW
610      IF (MONTH.GT.5.AND.MONTH.LT.10) TG=TGS
611      MOT=MONTH
612      S(4)=IEDAY(MONTH)
613      IF (RUNTYP.EQ.2) S(4)=ZBLDG(3)
614      S(6)=IDST
615      IF (RUNTYP.EQ.2) S(6)=0.
616      S(7)=0.2
617      S(8)=1.0
618      S(33)=1.
619      IF (IDETAL.EQ.0) GO TO 280
620      WRITE (6,1000)
621      280  CONTINUE
622      DO 270 I=1,NEXP
623      IF (ITYPE(I).LT.5) GO TO 300
624      DO 290 J=1,24
625      QSUN(I,J)=0.
626      QGLAS(I,J)=0.
627      290  QSKY(I,J)=0.
628      GO TO 360
629      300  WAZ=AZW(I)
630      S(9)=WAZ
631      S(10)=90.
632      IF (ITYPE(I).EQ.1) S(10)=0.

```

```

633         IF (ITYPE(I).NE.3) GO TO 301
634         SHDX(1)=SHAW(I,1)
635         SHDX(2)=SHAW(I,2)
636         SHDX(3)=SHAW(I,3)
637         SHDX(4)=SHAW(I,4)
638         SHDX(5)=SHAW(I,5)
639         SHDX(6)=SHAW(I,6)
640         SHDX(7)=SHAW(I,7)
641         SHDX(8)=SHAW(I,8)
642         SHDX(9)=SHAW(I,9)
643         SHDX(10)=SHAW(I,10)
644         SHDX(11)=SHAW(I,11)
645         SHDX(12)=SHAW(I,12)
646         SHDX(13)=SHAW(I,13)
647         SHDX(14)=SHAW(I,14)
648         SHDX(15)=SHAW(I,15)
649         301 CONTINUE
650         DO 350 J=1,24
651         QSKY(I,J)=0.
653         TIME=J
654         S(5)=TIME
655         CALI SUN
656         SALT(J)=S(20)
657         IF (S(25).GT.0.) GO TO 310
658         QSUN(I,J)=0.
659         QGLAS(I,J)=0.
660         GO TO 350
661         310 QSUN(I,J)=S(25)*ABS(I)
662         QGLAS(I,J)=0.
663         PHI=S(21)*PI/180.
664         XQ=S(20)*PI/180.
665         COSZ=SIN(XQ)
666         IF (SHD(I)) 311,311,312
667         312 SHDF(I,J)=0.
668         GO TO 345
669         311 SHDF(I,J)=1.
670         IF (SHDX(1)) 345,345,316
671         316 SHDX(16)=S(9)*PI/180.
672         CALL SHADOW(SHDX,PHI,COSZ,SHDF(I,J))
673         345 CONTINUE
674         IF (ITYPE(I).NE.3) GO TO 346
675         IF (TEXTSD.EQ.0) GO TO 347
676         IF (MONTH.GE.IEXMS.AND.MONTH.LE.IEXME) SHDF(I,J)=0.
677         347 CONTINUE
678         CALI GLASS(SHDF(I,J),SHADE(I),1.,1.,QGLAS(I,J))
679         346 CONTINUE
680         S34=S(25)-S(26)-S(27)
681         QSUN(I,J)=(S34*SHDF(I,J)+S(26)+S(27))*ABS(I)
682         350 CONTINUE
683         360 IF (IDETAL.NE.0) WRITE (6,930) I

```

```

684          IF (IDFTAL.NE.0) WRITE (6,940) (QSUN(I,J),J=1,24)
685          IF (IDFTAL.NE.0) WRITE (6,940) (QGLAS(I,J),J=1,24)
686          370 CONTINUE
687          DO 380 I=1,NEXP
688          DO 380 J=1,24
689          PGLAS(I,J)=QGLAS(I,J)
690          380 PSUN(I,J)=QSUN(I,J)
691          390 CONTINUE
692          IF (N.NE.1) GO TO 440
693          DO 400 J=1,24
694          DO 400 I=1,NEXP
695          400 TOS(I,J)=DB(24-J+1)-TIM
696          DO 410 J=25,48
697          DO 410 I=1,NEXP
698          410 TOS(I,J)=TOS(I,J-24)
699          DO 420 I=1,NEXP
700          DO 420 J=1,48
701          420 TIS(I,J)=0.
702          TA=TIM
703          DO 430 J=1,48
704          TNEW(J)=0.
705          430 TATTIC(J)=0.
706          IF (ASHRAE) 440,440,441
707          441 DO 443 I=1,NEXP
708          DO 442 J=1,24
709          442 TIS(I,J)=RMDBS(24-J+1)-TIM
710          DO 443 J=25,48
711          443 TIS(I,J)=TIS(I,J-24)
712          DO 444 II=1,2
713          HEATG(II)=0.
714          HEATX(II)=0.
715          HEATIS(II)=0.
716          HLCG(II)=0
717          HLCX(II)=0.
718          444 HLCIS(II)=0.
719          440 CONTINUE
720          % END OF INITIALIZATION
721          % TIME CALCULATION BEGINS HERE
722          DO 470 NK=1,24
723          LL1=NK.GE.ISTART.AND.NK.LE.ILEAVE
724          LL2=NK.LT.ISTART.OR.NK.GT.ILEAVE
725          IF (TTK.NE.0) GO TO 459
726          IF (TTHST.NE.1) GO TO 459
727          CALL TFMPSH(MONTH,JJ,NK,RMDBS,RMDBW,RMDBWO,RMDBSO,TA)
728          459 CONTINUE
729          IF (QUNTY.NE.2) GO TO 451
730          FOT=4.
731          ACHG=7ROOM(9)
732          CM=1.
733          GO TO 452

```

```

734      451  WSTX=WST(NK)
735      CALL FO (WSTX*.3,FOC,FOT,0)
736      % AIR CHANGE AS A FUNCTION OF WIND SPEED
737      % COHENZ AND ACHENBACH 1963 ASHRAE TRANSACTION
738      ACH=0.15+0.013*WST(NK)+0.005*ABS(UB(NK)-TA)
739      ACHG=ACH*CONST
740      CM=CCM(SALT(NK),NTOC(NK),TC(NK))
741      452  CFMI=A(1)*ACHG*HT/60.+CFMIN
742      CFMIX=CFML
743      CFMV=CFMS
744      IF (LI) GO TO 453
745      CFMV=0.
746      GO TO 454
747      453  IF (LI.GT.1) CFMV=0.
748      454  CONTINUE
749      DO 470 I=1,NEXP
750      NPR=NR(I)
751      OSUN(I,NK)=PSUN(I,NK)*CM
752      OGLAS(I,NK)=PGLAS(I,NK)*CM
753      QSKY(I,NK)=0.
754      IF (ITYPE(I).EQ.1) QSKY(I,NK)=2.*(1.-TC(NK))
755      IF (NRR.LT.2) GO TO 470
756      DO 450 NTT=2,NRR
757      450  TOY(NTT)=TOS(I,NTT-1)
758      DO 460 NTT=2,NRR
759      460  TOS(I,NTT)=TOY(NTT)
760      470  CONTINUE
761      DO 550 I=1,NEXP
762      NPR=NR(I)
763      IF (ASHRAF.GT.0) TIS(I,1)=TA-TIM
764      K=JPF(I)
765      DO 480 J=1,NRR
766      XDUM(J)=X(K,J)
767      YDUM(J)=Y(K,J)
768      ZDUM(J)=Z(K,J)
769      TDUM(J)=TOS(I,J)
770      IF (ITYPE(I).EQ.6.OR.ITYPE(I).EQ.7) TDUM(J)=TIS(I,J)
771      IF (JTYPE(I).EQ.5) TDUM(J)=TG-TIM
772      TI(I)=TIS(I,J)
773      480  CONTINUE
774      UX=U(I)
775      IF (H(I)) 500,500,490
776      490  H(I)=FOT
777      RX=1./UT(I)+1./(HI(I)+HR)
778      RXX=RX+1./H(I)
779      U(I)=1./RXX
780      UX=1./RX
781      500  CONTINUE
781.1  AUENDW=ABS(UENDW)
782      IF (ITYPE(I).EQ.1.AND).AUENDW.GT.1.E-5) GO TO 510

```

```

783          GO TO 530
784          510  ATCACG=AIRCHG*AIRNT
785             IF (I,1) ATCACG=AIRCHG
786             CALL ATTIC (XDUM,YDUM,ZDUM,CR(I),NRR,UX,H(I),DH(NK),QSUN(I,NK),QSKY(I,%
787                NK),TDUM,TATTIC,TNEW,TA,TIM,DRFO,DRF1,QU(I),QI(I),UENDW,UCELNG,AE%
788                NDW,A(I),ATCHT,ATCACG)
789             DO 520 J=1,NRR
790                TNEW(J)=TDUM(J)
791          520  TOS(I,J)=TATTIC(J)
792             GO TO 550
793          530  CONTINUE
794.01         IF (ITYPE(I).EQ.1.AND.UENDW.GT.1.E-5) FMAF=(FA-QI(I))/UCELNG
794.02         1563  FORMAT(' AT HOUR',I5,' ATTIC TEMPERATURE = ',F10.3)
794.03             HIRH=H(I)
794.04             IF (NHAY.NE.1) GO TO 9009
794.05             IF (ITYPE(I).NE.1) GO TO 9009
794.06             IF (MONTH.LE.4.OR.MONTH.GE.10) GO TO 9008
794.07             QSKY(I,NK)=QSKY(I,NK)+0.2*(DH(NK)-WBT(NK))*62.4*3.5/12.
794.08             IF (NK.GE.7.AND.NK.LE.20) QSUN(I,NK)=0.
794.09             IF (NK.GE.7.AND.NK.LE.20) QSKY(I,NK)=0.
794.1         IF (NK.GE.7.AND.NK.LE.20) HIRH=(H(I)*0.024)/(0.024+0.5*H(I))
794.11         GO TO 9009
794.12         9008  IF (NK.LE.7.OR.NK.GE.20) QSKY(I,NK)=0.
794.13         IF (NK.LE.7.OR.NK.GE.20) HIRH=(H(I)*0.024)/(0.024+0.5*H(I))
794.14         9009  CONTINUE
794.15         IF (PRINTP.EQ.2.AND.ND.FQ.7) WRITE(6,1560) HIRH,QSKY(I,NK)
794.16         1560  FORMAT(15F8.1)
795             CALL OUTSID (XDUM,YDUM,ZDUM,CR(I),JK,HIRH,DH(NK),TIM,QU(I),QI(I),Q%
796                SUN(I,NK),QSKY(I,NK),TDUM,II,TNEW,TA,ITEMP,DR)
797             DO 540 J=1,NRR
798          540  TOS(I,J)=TDUM(J)
799          550  CONTINUE
800             QOCPS(NK)=QOCUP(NK,JJ)*10.*(100.-TA)*QCU
801             QCCPL=10.*(TA-60.)*QOCUP(NK,JJ)*QCU
802             IF (TA-100.) 570,560,560
803          560  QOCPS(NK)=0.
804             QCCPL=400.*QOCUP(NK,JJ)*QCU
805             GO TO 590
806          570  IF (TA-65.) 580,590,590
807          580  QOCPS(NK)=350.*QOCUP(NK,JJ)*QCU
808             QCCPL=50.*QOCUP(NK,JJ)*QCU
809          590  DO 620 I=1,NEXP
810             NRR=NR(I)
811             IF (NRR.LT.2) GO TO 620
812             DO 600 NTT=2,NRR
813          600  TOY(NTT)=TIS(I,NTT-1)
814             DO 610 NTT=2,NRR
815          610  TIS(I,NTT)=TOY(NTT)
816          620  CONTINUE
817             IF (ASHRAE) 1621,1621,622

```

```

818      622      QSUMG=0.
819      QSUMX=0.
820      DO 623 I=1,NEXP
821      IF (ITYPE(I).LE.3.OR.ITYPE(I).EQ.8) QSUMX=QSUMX-QI(I)*A(I)
822      IF (ITYPE(I).EQ.3) QSUMG=QSUMG+QGLAS(I,NK)*A(I)
823      623      CONTINUE
824      HEATG(1)=HEATG(2)
825      HEATG(2)=QSUMG
826      HEATX(1)=HEATX(2)
827      HEATX(2)=QSUMX+QUCPS(NK)+QEQUP(NK)
828      HEATIS(1)=HEATIS(2)
829      NKK=NK-1
830      IF (NKK.EQ.0) NKK=24
831      HEATIS(2)=QLITE(NKK)
832      HLCG(1)=HLCG(2)
833      HLCX(1)=HLCX(2)
834      HLCIS(1)=HLCIS(2)
835      ISC=1
836      CALL RMRT(HEATG,HLCG,HEATX,HLCX,HEATIS,HLCIS,IW,IL,FC,ISC)
837      QL=HLCG(2)+HLCX(2)+HLCIS(2)+1.08*CFML*(DB(NK)-TA)
838      QGATN=HEATG(2)+HEATX(2)+HEATIS(2)
839      QL=-QL
840      GO TO 624
841      1621     CONTINUE
842      DO 1623 I=1,NEXP
843      HI(I)=0.542
844      HTEST=IIS(I,1)
845      IF (I.NE.1) GO TO 1624
846      IF (HTEST) 1625,1625,1626
847      1625     HI(1)=0.712
848      GO TO 1623
849      1626     HI(1)=0.162
850      GO TO 1623
851      1624     IF (I.NE.NEXP) GO TO 1623
852      IF (HTEST) 1627,1627,1628
853      1627     HI(NEXP)=0.162
854      GO TO 1623
855      1628     HI(NEXP)=0.712
856      1623     CONTINUE
857      IF (NTVNT.EQ.0) GO TO 1630
858      IF (DB(NK)-DBVMAX) 1632,1630,1630
859      1632     IF (TA-DBVMIN) 1630,1630,1631
860      1631     IF (JL.GT.1) GO TO 1633
861      IF (LL) GO TO 1630
862      1633     IF (QL+10) 1636,1630,1630
863      1636     CFML=CFMLX+CFMNT
864      1630     CONTINUE
865      V(1)=TV
866      IF (NVENT.NE.0) V(1)=DB(NK)
867      V(2)=CFML

```



```

868          V(3)=0.
869          IF(NVENT.NE.0) V(3)=CFMV
870          V(4)=FRAS
871          V(5)=FLCG
872          V(6)=TIM
873          V(7)=QCMAK
874          V(8)=QHMAX
875          IF(11.GT.1) GO TO 1634
876          IF(11.2) GO TO 1634
877          V(9)=TUL
878          V(10)=TLL
879          GO TO 1635
880 1634      V(9)=RMDRSO
881          V(10)=RMDRW
882 1635      CONTINUE
883          V(11)=TA
884          V(12)=FRAS
885          V(13)=HR
886          V(14)=METHOD
887          CALL RMTMK(V,TIF,QL,TA,NEXP,NK,ITK)
888 624      CALL PSY2(DB(NK),DPT(NK),PRT(NK),WRT(NK),PVO,WA,HA,VA,RHA)
889          PLAT(NK)=-QOCPL*ZNORM
890          WV=WA
891          QOCPL=QOCPL/1060.
892          IF(QL) 1645,1645,1646
893 1645      RHIN=PHS
894          GO TO 1647
895 1646      RHIN=RHW
895.1      IF(TA.GT.RMDRS(12)) GO TO 1640
895.2      IF(TA.LT.RMDRW(12)) GO TO 1640
896 1647      CONTINUE
897          CALL DRRH(TA,RHIN,WIN)
898          IF(DRS(QL)-1.) 1640,1640,640
899 1640      CONTINUE
900          WIN=(4.5*CFML*WA+QOCPL)/4.5/CFML
901 627      PVI=PB*WIN/(0.622+WIN)
902          RHIN=100.*PVI/PVSF(TA)
902.1      IF(RHIN.GT.100.) RHIN=100.
903 640      CONTINUE
904          CALDB(NK)=TA
905          CALPH(NK)=RHIN
906          AIRLAT(NK)=4.5*CFML*(WIN-WA)*1060.*ZNORM
907          RALD(NK)=QLITE(NK)*FLCG*ZNORM
908          BASFL(NK)=(QLITE(NK)+QEQU(NK))*ZNORM
909          AIRLK(NK)=1.08*(CFML+CFMV)*(TA-DB(NK))*ZNORM
910          QSOL(NK)=PSUN(1,NK)
911          QLATNT=(4.5*CFML*(WIN-WA)+4.5*CFMV*(WIN-WV)-QOCPL)*1060.
912          IF(QUNTP.EQ.2) GO TO 641
913          IF(ASHRAE.EQ.0) GO TO 641
914          CALL ADJUST(QL,QLATNT,MONTH,NK,JJ)

```

```

915      641  CONTINUE
916      QL=OL*1.0B*CFMV*(TA-DR(NK))
917      QLS(NK)=QL*ZNORM
918      QLL(NK)=QLATNT*ZNORM
919      IF (ABS(QLS(NK))-1.)642,642,643
920      642  QLL(NK)=0.
921      643  CONTINUE
922      IF (AUENDW.LT.1.E-5) GO TO 1147
923      650  NRR=NR(1)
924      DO 660 J=1,NRR
925      660  TOS(1,J)=TNEW(J)
925.01    1147 IF (RINTYP.NE.2.OR.NO.LT.7) GO TO 670
925.02    %  WRITE(6,1562)
925.03    1562 FORMAT(' HOUR TYPE SURFACE CONSTRUCT ANGLE FLUX AREA LOAD PER CENT')
925.04    QPTOT=0.
925.05    DO 8910 I=1,NEXP
925.06    QRR=0.
925.07    IF (ITYPE(I).LE.5.OR.ITYPE(I).EQ.8) QRR=Q1(I)*A(I)
925.08    IF (ITYPE(I).EQ.3) QRR=-QGLAS(1,NK)*A(I)+QRR
925.09    QZ=QRR/A(I)
925.10    QPTOT=QPTOT+QRR
925.11    %  WRITE(6,1561) NK,ITYPE(I),IRF(I),AZW(I),QZ,A(I),QRR,QSUN(1,NK),QSKY(1,NK),QGLAS(1,NK)
925.12    1561 FORMAT(3I10,7F12.3)
925.13    8910  CONTINUE
925.14    QPTOT=QPTOT-QOCPS(NK)-QEUP(NK)-QLITE(NK)
925.15    IF (ITYPE(I).EQ.1.AND.AUENDW.GT.1.E-5) WRITE(6,1563) NK,TEMAT
925.16    %  WRITE(6,1564) QPTOT
925.17    1564 FORMAT(' QTOT = ',E16.8)
926      670  CONTINUE
927      IF (RINTYP.EQ.2.AND.NO.LT.7) GO TO 740
928      QLMAX=ABS(QLS(1))
929      NMAX=1
930      TSUM=0.
931      QLDSUM=0.
932      CLDAY=0.
933      HLDAY=0.
934      DO 720 NK=1,24
935      IF (QLMAX=ABS(QLS(NK))) 680,690,690
936      680  QLMAX=ABS(QLS(NK))
937      NMAX=NK
938      GO TO 690
939      690  CONTINUE
940      TSUM=TSUM+DB(NK)
941      QLDSUM=QLDSUM+QLS(NK)+QLL(NK)
942      QLDS=QLS(NK)+QLL(NK)
943      IF (QLDS) 700,700,710
944      700  CLDAY=CLDAY+QLDS
945      GO TO 720
946      710  HLDAY=HLDAY+QLDS
947      720  CONTINUE

```

```

948          TCLLD=TCLLD+CLDAY
949          THTLD=THTLD+HLDAY
950          DBA=TSUM/24.
951          QLMAX=QLS(NMAX)+QLL(NMAX)
952          IF(RUNTYP.EQ.2) N=1
953          IF(N.GT.1) GO TO 722
954          WRITE(6,760) NAMERM
955          722  CONTINUE
956          WRITE(6,770) MONTH,LDAY,NMAX,QLMAX,CLDAY,HLDAY,DBA
956.1        IF(MD.EQ.NEND) WRITE(6,874)
957          IF(RUNTYP.NE.2) GO TO 721
957.1        IF(MD.NE.NEND) WRITE(6,874)
958          WRITE(6,780) YEAR,MONTH,LDAY
959          WRITE(6,871)
960          871  FORMAT(///'          TIME          DBOUT          WBOU          DBIN          RHIN          %
961          QLS          QLL')
962          DO 872 J=1,24
963          872  WRITE(6,873) J,DB(J),WRT(J),CALDR(J),CALRH(J),QLS(J),QLL(J)
964          873  FORMAT(I10,4F10.1,2F10.0)
965          WRITE(6,874)
966          874  FORMAT(///)
967          721  CONTINUE
968          IF(IDETAL.EQ.0) GO TO 730
969          WRITE(6,1020) DBA,QLDSUM
970          WRITE(6,1030) CLDAY,HLDAY
971          WRITE(6,1040) N,TCLLD,N,THTLD
972          730  CONTINUE
973          IF(TAPE2.EQ.0) GO TO 740
974          WRITE(TAPE2) NAMERM,MONTH,LDAY,DB,DPI,WBT,WST,PBT,TC,NTOC,CALDB,C%
975          ALRH,QLS,QLL,DBA,CLDAY,HLDAY,TCLLD,THTLD,QLITE,GEQUP,QSOL,QOCPS,AIRLK
976          WRITE(10) QLS,PLAT,AIRLAT,DR,DPT,CALDB,RALD,BASEL
977          740  CONTINUE
978          CLDSUM=CLDSUM+TCLLD
979          HLDSUM=HLDSUM+THTLD
980          WRITE(6,1050) IJKLMN,CLDSUM,IJKLMN,HLDSUM
981          REWIND 7
982          750  CONTINUE
983          END FILE TAPE2
984          END FILE 10
985          STOP
986          %
987          %
988          %
989          760  FORMAT(///'          ROOM NAME= '9A4/////          MONTH          DAY          MHR          %
990          QLMAX          CLDAY          HLDAY          DBA')
991          770  FORMAT(3I10,3F10.0,F10.1)
992          780  FORMAT (' ***** YEAR =',I5,' ***** MONTH =',I3,' ***** DAY =',I3/)
993          790  FORMAT (8H ROOMNO,6X'H',6X'AG',3X'NOFLR',5X'QCU',2X'ARCHGS',2X'A%
994          RCHGW')
995          800  FORMAT(15F8.1)

```

```

996      810  FORMAT (5X'LAT',4X'LONG',5X'TZN',3X'ZORM')
997      820  FORMAT (3X'QLITY',3X'QEQPX',4X'CFMV',4X'DBIN',6X'TG',6X'TV',4X'DPI%
998      N')
999      830  FORMAT (/ ' UENDW UCFLNG AENDW ATCHT')
1000     840  FORMAT (6X,'NEXP',7X,'ITK',5X,'ITHST'/3(8X,I2))
1001     850  FORMAT (1H ,6A6)
1002     860  FORMAT (' CLIMATIC DATA FOR DAY=',(5/' DAYS ELAPSED SINCE JAN 1=%
1003     ',I5,' YEAR=',I5,' MONTH=',I5,' DAY=',I5)
1004     870  FORMAT (' DH'/2(12F10.2/)' WHT'/2(12F10.2/)' CALDH'/2(12F10.2/)' C%
1005     ALRH'/2(12F10.2/)' SENSIBLE LOAD'/2(12F10.0/)' LATENT LOAD'/2(12%
1006     F10.0/))
1007     880  FORMAT(10I7)
1008     890  FORMAT (10I7)
1009     900  FORMAT (10F7.0)
1010     910  FORMAT (1X,9A4)
1010.1   911  FORMAT (9A4)
1011     920  FORMAT (I3,3I10,8F10.2)
1012     930  FORMAT (I10,F10.0)
1013     940  FORMAT (24F5.0)
1014     950  FORMAT(' SURFACE NO ITYPE IHT IRF ABSP%
1014.1   U H',9%
1015     X',A',9X,'WAZ',5X,'SHADE',8X,'OUT',8X,'HI')
1016     960  FORMAT (// ' SHADOW CASTING DATA//' FL%
1017     HT FP AW HWL HWR D FPI%
1018     A1 B1 C1 FP2 A2 B2 C2')
1019     970  FORMAT (///' RADIATION INTERCHANGE FACTORS')
1020     980  FORMAT (' SURFACE 1 2 3 4
1021     5 6 7 8 9 10')
1022     990  FORMAT (I10,10F10.3)
1023     1000  FORMAT (' SOLAR DATA (GSUN/UGLASS)')
1024     1010  FORMAT (' ' /' ')
1025     1020  FORMAT (' DBA =',F6.2/ ' QLSUM =',F10.0//)
1026     1030  FORMAT (' TOTAL COOLING CONSUMPTION PER DAY =',F10.0,' BTU// TOTAL%
1027     L HEATING CONSUMPTION PER DAY =',F10.0,' BTU')
1028     1040  FORMAT (' TOTAL COOLING CONSUMPTION FOR THE ROOM OVER THE ',I3,' *
1029     DAY PERIOD =',E11.5,' BTU// TOTAL HEATING CONSUMPTION FOR THE ROOM%
1030     M OVER THE ',I3,' DAY PERIOD =',E11.5,' BTU')
1031     1050  FORMAT (' TOTAL COOLING CONSUMPTION FOR ',I2,' ROOMS =',E11.5,' BT%
1032     U// TOTAL HEATING CONSUMPTION FOR ',I2,' ROOMS =',E11.5,' BTU')
1033     1051  FORMAT(///' CONGRATULATIONS!! NOW YOU ARE ON NBSLD')
1034     1052  FORMAT(/ ' WE ASSUME YOU HAVE ALREADY PREPARED THE DATA')
1035     1053  FORMAT(' ON NBS DATA FORMS..IF YOU HAVE NOT, PLEASE TURN OFF')
1036     1054  FORMAT(' THE TERMINAL AND HAVE YOUR DATA READY ON THE DATA FORMS')
1037     END

```

```

1      SUBROUTINE OUTSID (X,Y,Z,CR,UX,FO,DB,TIM,Q0,QI,QSUN,QSKY,TO,TI,TON*
2      FW,TA,ITEMP,NR)
3      DIMENSION TO(1),TI(1),X(1),Y(1),Z(1)
4      XNUM=QSUN-QSKY+FO*(DB-TIM)
5      IF (NR.NE.1) GO TO 50
6      IF (FO) 20,20,30
7      TONEW=TO(1)
8      GO TO 40
9      30  TAM=TA-TIM
10     TONEW=(XNUM+UX*TAM)/(UX+FO)
11     40  CONTINUE
12     Q0=IX*(TAM-TONEW)
13     IF (ITEMP.EQ.0) QI=Q0
14     TO(1)=TONEW
15     GO TO 90
16     50  SUMZ=0.
17     SUMY=Y(1)*TI(1)
18     SUMX=X(1)*TI(1)
19     SUMXY=0.
20     DO 60 J=2,NR
21     SUMY=SUMY+Y(J)*TI(J)
22     SUMX=SUMX+X(J)*TI(J)
23     SUMXY=SUMXY+Y(J)*TO(J)
24     60  SUMZ=SUMZ+Z(J)*TO(J)
25     XNUM=SUMY-SUMZ+CR*Q0+XNUM
26     TONEW=XNUM/(Z(1)+FO)
27     IF (FO) 70,70,30
28     70  TONEW=TO(1)
29     TO(1)=TONEW
30     SUMZ=SUMZ+Z(1)*TO(1)
31     SUMXY=SUMXY+Y(1)*TO(1)
32     Q0=SUMY-SUMZ+CR*Q0
33     IF (ITEMP.EQ.0) QI=SUMX-SUMXY+CR*QI
33.1   90  CONTINUE
34     RETURN
35     END

```

```

1      SUBROUTINE PSY1 (DB,WB,PB,DP,PV,W,H,V,RH)
2      PVP=PVSF (WR)
3          IF (DB-WB) 30,30,10
4      10      WSTAR=0.622*PVP/(PB-PVP)
5          IF (WB-32.) 20,20,40
6      20      PV=PVP-5.704E-4*PB*(DB-WB)/1.8
7          GO TO 50
8      30      PV=PVP
9          GO TO 50
10     40      CDB=(DB-32.)/1.8
11         CWR=(WB-32.)/1.8
12         HL=597.31+0.4409*CDB-CWR
13         CH=0.2402+0.4409*WSTAR
14         EX=(WSTAR-CH*(CDB-CWR)/HL)/0.622
15         PV=PB*FX/(1.+EX)
16     50      W=0.622*PV/(PB-PV)
17         V=0.754*(DB+459.7)*(1+7000*W/4360)/PB
18         H=0.24*DB+(1061+0.444*DB)*W
18.1     IF (PV.LE.0) GO TO 60
18.2     IF (DB.NE.WB) GO TO 70
18.3     DP=DB
18.4     RH=1.
18.5     GO TO 60
18.6     70 CONTINUE
19         DP=DPF (PV)
20         RH=PV/PVSF (DB)
21     60 RETURN
22         END

```



```

1          SUBROUTINE PSY2 (DB,DP,PH,WR,PV,W,H,V,RH)
2          % THIS SUBROUTINE CALCULATES THE FOLLOWINGS WHEN DRY-BULB TEMPERATURE
3          % (DB),DEW-POINT TEMPERATURE(DP),AND BAROMETRIC PRESSURE(PH) ARE GIVEN
4          % WR WET-BULB TEMPERATURE
5          % W HUMIDITY RATIO
6          % H ENTHALPY
7          % V VOLUME
8          % PV VAPOR PRESSURE
9          % RH RELATIVE HUMIDITY
10         IF (DP-DB) 20,10,10
11         10 DP=DB
12         20 PV=PVSF (DP)
13         PV=PVSF (DB)
14         PVS=PVSF (DB)
15         RH=PV/PVS
16         W=0.622*PV/(PH-PV)
17         V=0.754*(DB+459.7)*(1+7000*W/4360)/PH
18         H=0.24*DB+(1061+0.444*DB)*W
19         IF (H) 30,30,40
20         30 WR=DP
21         RETURN
22         40 WR=WRF (H,P3)
23         RETURN
24         END

```

```

1      FUNCTION PVSF (X)
2      DIMENSION A(6)/-7.90298,5.02808,-1.3816E-7,11.344.8.1328E-3,-3.491%
3      49/,R(4)/-9.09718,-3.56654,0.876793,0.0069273/,P(4)
4      T=(X+459.688)/1.8
5      IF (T.LT.273.16) GO TO 10
6      Z=373.16/T
7      P(1)=A(1)*(Z-1)
8      P(2)=A(2)*LOG10(Z)
9      Z1=A(4)*(1-1/Z)
10     P(3)=A(3)*(10**Z1-1)
11     Z1=A(6)*(Z-1)
12     P(4)=A(5)*(10**Z1-1)
13     GO TO 20
14     Z=273.16/T
15     P(1)=R(1)*(Z-1)
16     P(2)=R(2)*LOG10(Z)
17     P(3)=R(3)*(1-1/Z)
18     P(4)=LOG10(R(4))
19     SUM=0
20     DO 30 I=1,4
21     SUM=SUM+P(I)
22     PVSF=29.921*10**SUM
23     RETURN
24     END

```

```

1          SURROUTINE RESF (XX,YY,ZZ,IRUN)
2          % THIS PROGRAM IS DEVELOPED BY T.KUSUDA OF THE NATIONAL BUREAU OF
3          % STANDARDS FOR CALCULATING THE THERMAL RESPONSE FACTORS FOR
4          % COMPOSITE WALLS,FLOORS,ROOFS,BASEMENT WALLS BASEMENT FLOORS
5          % AND INTERNAL FURNISHINGS OF SIMPLE SHAPES
6          % RESPONSE FACTORS ARE USED IN THE FOLLOWING MANNER
7          % X,Y,Z ARE RESPONSE FACTORS
8          % QI=X*TI-Y*TO*GMA   INSIDE WHERE R IS MINIMUM
9          % QO=Y*TI-Z*TO   OUTSIDE WHERE R IS MAXIMUM
10         % TI   INSIDE TEMPERARURE WHERE R IS MINIMUM
11         % TO   OUTSIDE TEMPERATURE WHERE R IS MAXIMUM
12         % K   THERMAL CONDUCTIVITY
13         % G   THERMAL DIFFUSIVITY
14         % L   THICKNESS
15         % IN=0  FINITE THICK WALL
16         % IN=1  SEMI-FINITE WALL
17         % IN=2  SOLID OBJECT
18         % IF RESPONSE FACTORS OF THE SOLID CYLINDER OR SPHERE OF HOMOGENEOUS
19         % PROPERTY ARE DESIRED, TREAT THE PROBLEM OF MULTILAYER BUT WITH THE
20         % IDENTICAL PROPERTIES FOR ALL THE LAYERS EXCEPT THE RADIUS
21         REAL K(10),G(10),L(10),KG
22         DIMENSION X(100),Y(100),Z(100),C(10),D(10),RES(10),RMK(10,6)
23         DIMENSION RMKG(6),F(100),XX(100,I),YY(100,I),ZZ(100,I),FF(100,20)
24         DELTAT=1.
25         IRUN=0
25.1        IN=0
25.2        WRITE(6,241)
25.3        241 FORMAT(' DATA SHEET NO 6 N/L,K,P,C,R')
26         20 READ(5,*) NLAYR
27         IF (NLAYR.EQ.0) GO TO 200
28         IRUN=IRUN+1
29         IF (NLAYR.GT.10) GO TO 200
30        >NNLAYR=NLAYR+1
31         IF (NLAYR.EQ.0) GO TO 40
32         DO 30 I=1,NLAYR
33         30 READ (5,*) L(I),K(I),D(I),C(I),RES(I)
33.1        WRITE(6,242)
33.2        242 FORMAT(' DATA SHEET NO 7: DESCRIPTION OF EACH LAYER')
34         IF (IN.EQ.2) GO TO 50
35         % READ K,RHO, AND C OF GROUND IF IN=1
36         % FOLLOWINGS ARE GROUND THERMAL CONDUCTIVITY, DENSITY AND SP.HT IF
37         % IN=2. OTHERWISE THE SAME PROPERTIES OF THE INTERNAL SLAB
38         40 IF (IN.NE.0) READ (5,*) KG,DG,CG
39         % AG THERMAL DIFFUSIVITY OF EARTH
40         IF (IN.NE.0) AG=KG/CG/DG
41         IF (NLAYR.EQ.0) GO TO 100
42         IF (IN.EQ.2) READ (5,330) (RMKG(J),J=1,4)
43         50 DO 60 I=1,NLAYR
44         60 READ (5,330) (RMK(I,J),J=1,4)
45         IF (IN.EQ.1) READ (5,330) (RMKG(J),J=1,4)

```

```

46          DO 90 I=1,NLAYR
47          IF (L(I)) 80,70,80
48          70  G(I)=0.
49          K(I)=1./RES(I)
50          GO TO 90
51          80  G(I)=K(I)/C(I)/D(I)
52          90  CONTINUE
53          100 CONTINUE
54          CALL RESPTK (K,L,G,AG,KG,X,Y,Z,NLAYR,DELTAT,NRT,CR,UT,IN,F)
55          WRITE (6,220) IRUN
56          WRITE (6,350)
57          WRITE (6,250)
58          WRITE (6,260)
59          WRITE (6,210)
60          IF (NLAYR.EQ.0) GO TO 130
61          IF (JN.EQ.2) WRITE (6,360) KG,DG,CG,(RMKG(J),J=1,4)
62          DO 120 I=1,NLAYR
63          IF (L(I)) 120,110,120
64          110  K(I)=0.
65          120  WRITE (6,270) I,L(I),K(I),D(I),C(I),RES(I),(RMK(I,J),J=1,6)
66          IF (IN.EQ.1) WRITE (6,360) KG,DG,CG,(RMKG(J),J=1,6)
67          130  WRITE (6,290) DELTAT
68          WRITE (6,280) UT
69          WRITE (6,300)
70          WRITE (6,210)
71          IF (IN.NE.0) GO TO 150
72          WRITE (6,310)
73          XX(1,IRUN)=FLOAT(NRT)
74          YY(1,IRUN)=FLOAT(NRT)
75          ZZ(1,IRUN)=FLOAT(NRT)
76          XX(2,IRUN)=CR
77          YY(2,IRUN)=CR
78          ZZ(2,IRUN)=CR
79          XX(NRT+3,IRUN)=UT
80          DO 140 N=1,NRT
81          XX(N+2,IRUN)=X(N)
82          YY(N+2,IRUN)=Y(N)
83          ZZ(N+2,IRUN)=Z(N)
84          JN=N-1
85          140  WRITE (6,320) JN,X(N),Y(N),Z(N)
86          GO TO 190
87          150  WRITE (6,370)
88          IF (IN.EQ.1) GO TO 170
89          IF (IN.EQ.2) GO TO 170
90          XX(1,IRUN)=FLOAT(NRT)
91          XX(2,IRUN)=CR
92          XX(NRT+3,IRUN)=UT
93          DO 160 N=1,NRT
94          JN=N-1
95          X(N)=-X(N)

```

```

96      XX(N+2,IRUN)=X(N)
97      160  WRITE (6,380) JN,X(N)
98      GO TO 190
99      170  DO 180 N=1,NRT
100     JN=N-1
101     FF(N+2,IRUN)=F(N)
102     180  WRITE (6,380) JN,F(N)
103     FF(1,IRUN)=FLOAT(NRT)
104     FF(2,IRUN)=CR
105     FF(NRT+3,IRUN)=UT
106     190  WRITE (6,210)
107     WRITE (6,210)
108     WRITE (6,340) CR
109     GO TO 20
110     200  RETURN
111     *
112     %
113     %
114     210  FORMAT (2H0 )
115     220  FORMAT (*1 IRF=*I10)
116     230  FORMAT (10I7)
117     240  FORMAT (10F7.0)
118     250  FORMAT (77H0 LAYER      L(I)      K(I)      (I)      C(I)      RES(%
119     1)  DESCRIPTION      )
120     260  FORMAT (77H  NO              *
121     OF LAYERS      )
122     270  FORMAT (116,1F11.3,1F10.3,1F10.2,1F10.3,1F8.2,2X,6A4)
123     280  FORMAT (59H0              THERMAL CONDUCTANCE      %
124     UT=1F7.3)
125     290  FORMAT (49H0              TIME INCREMENT DT=1F3.0)
126     300  FORMAT (50H0              RESPONSE FACTORS)
127     310  FORMAT (120H0              J      X      Y %
128     Z
129     )
130     320  FORMAT (1117,1F23.4,2F15.4)
131     330  FORMAT (6A4)
132     340  FORMAT (44H0              COMMON RATIO CR=1F7.5)
133     350  FORMAT (50H0  WALL COMPOSITION      )
134     360  FORMAT (1F27.3,1F10.2,1F10.3,10X,6A4)
135     370  FORMAT (50H0              J      F      )
136     380  FORMAT (1124,1F21.5)
137     FND)

```

```

10      SUBROUTINE RESFX (X,Y,Z,XX,YY,ZZ,NR,CR,UT,NEXP)
11      DIMENSION XX(100,10),YY(100,10),ZZ(100,10)
12      DIMENSION X(10,100),Y(10,100),Z(10,100),NR(10),CR(10),UT(10)
13      TEST=1.E-6
14      DO 10 K=1,10
15      DO 10 J=1,100
16      XX(I,K)=0
17      YY(I,K)=0
18      10  ZZ(J,K)=0
19      CALL RESF (XX,YY,ZZ,IRUN)
20      DO 30 K=1,NEXP
21      I=K
21.1    IF (YY(5,K)) 101,101,102
21.2    101 YY(3,K)=0.
21.3    YY(4,K)=0.
21.4    YY(5,K)=0.
21.5    102 CONTINUE
22      IF (K.GT,IRUN) GO TO 30
23      X(I,1)=XX(3,K)
24      Y(I,1)=YY(3,K)
25      Z(I,1)=ZZ(3,K)
26      NR(I)=XX(1,K)
27      CR(I)=XX(2,K)
28      JJJ=NR(I)+3
29      UT(I)=XX(JJJ,K)
30      NMAX=NR(1)
31      WRITE(6,31) K
32      31  FORMAT(//'      CONDUCTION TRANSFER FUNCTIONS FOR  IRF='I10/'
33      '      J      X      Y      Z      CR/')
34      J1=1
35      WRITE(6,32) J1,X(I,1),Y(I,1),Z(I,1),CR(I)
36      DO 20 J=2,NMAX
37      J3=J+2
38      J2=J+1
39      X(I,J)=XX(J3,K)-XX(J2,K)*CR(I)
40      Y(I,J)=YY(J3,K)-YY(J2,K)*CR(I)
41      IF (ABS(X(I,J))-TEST) 40,40,41
42      40  NR(I)=J
43      GO TO 30
44      41  CONTINUE
45      1  Z(I,J)=ZZ(J3,K)-ZZ(J2,K)*CR(I)
46      JK=J
47      WRITE(6,32) JK,X(I,J),Y(I,J),Z(I,J)
48      32  FORMAT(I10,4F10.5)
49      20  CONTINUE
50      30  CONTINUE
51      RETURN
52      END

```



```

1          SURROUTINE RESPTK (K,L,G,AG,KG,X,Y,Z,NL,DT,NR,CR,U,IS,F)
2          DIMENSION K(10),L(10),G(10),X(100),Y(100),Z(100),AP(10),BP(10),CP(
3 10),DP(10),A(10),B(10),C(10),D(10),ZR1(3),ZR2(3),RB(3),RAP(3),ROOT%
4 (100),RA(3,100),ZRK(3,100),RX(100),RY(100),AZ(100),F(100)
5          REAL K,L,KG
6          PI=4.*ATAN(1.)
7          M3=3
8          IF (IS.NE.1) GO TO 10
9          ZL=KG/I0.
10         UY=100./AG/DT
11         CALL GPF (UY,ZL,AZ)
12         IF (IS.EQ.1.AND.NL.EQ.0) GO TO 330
13 10        CALL ABCD2 (0.,K,L,G,AX,BX,CX,DX,NL)
14         RR(1)=DX
15         RR(2)=1.
16         RR(3)=AX
17         U=1./RX
18         DO 20 I=1,NL
19         PX=0
20         CALL ABCDP2 (PX,K(I),L(I),G(I),AP(I),BP(I),CP(I),DP(I))
21 20        CALL ABCD2 (PX,K(I),L(I),G(I),A(I),B(I),C(I),D(I),1)
22         IF (NL.LT.2) GO TO 30
23         CALL DERVT (A,B,C,D,AP,BP,CP,DP,APP,BPP,CPP,DPP,NL)
24         GO TO 40
25 30        APP=AP(1)
26         BPP=BP(1)
27         CPP=CP(1)
28         DPP=DP(1)
29 40        RAP(1)=DPP
30         RAP(2)=0.
31         RAP(3)=APP
32         DO 50 I=1,3
33         C1=RAP(I)/BX/DT
34         C2=RR(I)*BPP/BX/BX/DT
35         ZR2(I)=-C1+C2
36 50        ZR1(I)=-ZR2(I)+RR(I)/BX
37 *        ROOTS OF R(P)=0.
38         NMAX=10
39         TESTMX=40.
40         PX=0.001
41         DPP=0./DT
42         DLX=0.0001
43         N=0
44 60        DL=DPP
45         CALL ABCD2 (PX,K,L,G,AX,BX,CX,DX,NL)
46 70        PXP=PX+DL
47         CALL ABCD2 (PXP,K,L,G,AXP,BXP,CXP,DXP,NL)
48         IF (BX*BXP) 90,110,80
49 80        PX=PXP
50         BX=BXP

```

```

51          TESTX=PX*DT
52          IF (TESTX-TESTMX) 70,170,170
53          90  IF (DL-DLX) 140,140,100
54          100 DL=DL/2.
55          GO TO 70
56          110 IF (RX) 130,120,130
57          120 RXX=PX
58          GO TO 150
59          130 RXX=XPX
60          GO TO 150
61          140 AR=ARS (RX/BXP)
62          RXX=(PX+AR*XPX)/(1.+AR)
63          150 N=N+1
64          ROOT(N)=RXX
65          IF (N.GT.1) DPO=ROOT(N)-ROOT(N-1)
66          NRT=N
67          PX=RXX+DLX
68          TESTX=PX*DT
69          IF (TESTX-TESTMX) 160,160,170
70          160 IF (N.LT.NMAX) GO TO 60
71          170 CONTINUE
72          IF (ROOT(NRT)-100.) 190,180,180
73          180 NRT=NRT-1
74          190 DO 250 JJ=1,NRT
75          PX=ROOT(JJ)
76          DO 200 J=1,NL
77          CALL ABCD2 (PX,K(J),L(J),G(J),A(J),B(J),C(J),D(J),1)
78          200 CALL ABCD2 (PX,K(J),L(J),G(J),AP(J),BP(J),CP(J),DP(J))
79          CALL ABCD2 (PX,K,L,G,AX,BX,CX,DX,NL)
80          IF (NL.LT.2) GO TO 210
81          CALL DERVT (A,B,C,D),AP,BP,CP,DP,APP,BPP,CPP,DPP,NL)
82          GO TO 220
83          210 APP=AP(1)
84          BPP=BP(1)
85          CPP=CP(1)
86          DPP=DP(1)
87          220 PY=BPP*PX*PX*DT
88          RA(1,JJ)=DX/PY
89          RA(2,JJ)=1./PY
90          RA(3,JJ)=AX/PY
91          PZ=PX*DT
92          IF (PZ-20.) 240,240,230
93          230 RX(JJ)=0.
94          RY(JJ)=25.E16
95          GO TO 250
96          240 RX(JJ)=EXP(-PZ)
97          RY(JJ)=(1.-EXP(PZ))**2
98          250 CONTINUE
99          DO 260 JJ=1,NRT
100         DO 260 M=1,M3

```

```

101      ZR1(M)=RA(M,JJ)*RX(JJ)+ZR1(M)
102      ZR2(M)=RA(M,JJ)*(RX(JJ)*RX(JJ)-2.*RX(JJ))+ZR2(M)
103      II=1
104      III=?
105      IF (ZR1(2).LT.0) ZR1(2)=0.
106      DO 270 M=1,M3
107      ZRK(M,1)=ZR1(M)
108      ZRK(M,2)=ZR2(M)
109      NT=100
110      DO 300 N=3,NT
111      NR=N
112      DO 280 M=1,M3
113      ZRK(M,N)=0.
114      DO 290 M=1,M3
115      DO 290 JJ=1,NRT
115.1    IF(RX(JJ).GT.1.E-10) GO TO 292
115.2    PZ=0.
115.3    GO TO 290
115.4    292 CONTINUE
116      PZ=(RX(JJ))*N
117      ZRK(M,N)=ZRK(M,N)+PZ*RY(JJ)*RA(M,JJ)
118      IF (N.LT.5) GO TO 300
118.1    IF (ZRK(1,N-1)*ZRK(1,N-2)) 291,310,291
119      291 TEST1=ZRK(1,N)/ZRK(1,N-1)
120      TEST2=ZRK(1,N-1)/ZRK(1,N-2)
121      TEST3=ABS(TEST1-TEST2)
122      IF (TEST3-0.001) 310,310,300
123      300 CONTINUE
124      310 DO 320 N=1,NR
125      X(N)=ZRK(1,N)
126      Y(N)=ZRK(2,N)
127      320 Z(N)=ZRK(3,N)
128      CR=TEST2
128.1    IF (X(3)) 321,322,321
128.2    322 CR=0.
128.3    321 CONTINUE
129      IF (IS.EQ.2) GO TO 450
130      IF (IS.NE.1) GO TO 470
131      330 IF (NL.EQ.0) GO TO 390
132      GF=2*KG/SQRT(DT*AG*PI)
133      IF (NR.LT.50) GO TO 350
134      DO 340 J=50,NR
135      ZJ=J
136      340 AZ(J)=GF*(SQRT(7J)-2.*SQRT(ZJ-1.))+SQRT(ZJ-2.)
137      NRR=NR
138      GO TO 370
139      350 DO 360 J=NR,50
140      Z(J+1)=Z(J)*CR
141      X(J+1)=X(J)*CR
142      360 Y(J+1)=Y(J)*CR

```

```
143          NRR=50
144      370  DO 380 J=1,NRR
145      380  F(J)=X(J)-Y(J)*Y(J)/(Z(J)+AZ(J))
146          NR=NRR
147          GO TO 410
148      390  DO 400 J=1,NR
149      400  F(J)=AZ(J)
150      410  CONTINUE
151          CR1=1.
152          DO 430 J=1,50
153          CR=F(J+1)/F(J)
154          TESTCR=ABS(CR-CR1)
155          IF (TESTCR-0.001) 440,440,420
156      420  CR1=CR
157          JJ=J-1
158      430  CONTINUE
159      440  NR=J
160          CR=CR1
161          GO TO 470
162      450  CONTINUE
163          DO 460 J=1,NR
164          F(J)=X(J)+Z(J)-2.*Y(J)
165          JJ=J-1
166      460  CONTINUE
167      470  RETURN
168          %
169          %
170          END
```

```

1      SUBROUTINE RMRT(HEATG,HLCG,HEATX,HLCX,HEATIS,HLCIS,IW,IL,FC,ISC)
1.1    %   FC: CORRECTION FACTOR FOR THE HEAT LOST TO THE SURROUNDINGS
1.2    %   ISC: SHADING COEFFICIENT INDEX IF ISC=0 EXTERNAL SHADING
1.3    %   OTHERWISE INTERNAL SHADING
2      DIMENSION HEATG(2),HLCG(2),HEATX(2),HLCX(2),HEATIS(2),HLCIS(2)
3      DIMENSION AGO(3),AG1(3),AXO(3),AIS1(4,3),AIS2(4,3),B1(3),AX1(3)
4      DATA AGO/0.187,0.197,0.224/,AG1/-0.097,-0.067,-0.044/
5      DATA B1/-0.91,-0.87,-0.82/
6      DATA AXO/0.676,0.681,0.703/,AX1/-0.586,-0.551,-0.523/
7      DATA (AIS1(I,J),J=1,3)/0.53,0.53,0.53/
8      DATA (AIS2(I,J),J=1,3)/-0.44,-0.40,-0.35/
9      DATA (AIS1(2,J),J=1,3)/0.59,0.59,0.59/
10     DATA (AIS2(2,J),J=1,3)/-0.50,-0.46,-0.41/
11     DATA (AIS1(3,J),J=1,3)/0.87,0.87,0.87/
12     DATA (AIS2(3,J),J=1,3)/-0.78,-0.74,-0.69/
13     DATA (AIS1(4,J),J=1,3)/0.50,0.50,0.50/
14     DATA (AIS2(4,J),J=1,3)/-0.41,-0.37,-0.32/
31     HLCG(2)=FC*(AGO(IW)*HEATG(2)+AG1(IW)*HEATG(1))-B1(IW)*HLCG(1)
32     HLCX(2)=FC*(AXO(IW)*HEATX(2)+AX1(IW)*HEATX(1))-B1(IW)*HLCX(1)
33     HLCIS(2)=FC*(AIS1(IL,IW)*HEATIS(2)+AIS2(IL,IW)*HEATIS(1))-B1(IW)*HLCIS(1)
34     IF (ISC.EQ.0) RETURN
35     HLCG(2)=FC*(AXO(IW)*HEATG(2)+AX1(IW)*HEATG(1))-B1(IW)*HLCG(1)
36     RETURN
37     END

```

```

1      SUBROUTINE RMTMK(V,TIF,QL,TA,NEXP,NX,ITK)
2      COMMON/CC/ X(10,100),Y(10,100),Z(10,100),ITYPE(30)%
3      ,IHT(30),IRF(30),ABSP(30),U(30),H(30),HI(30),A(30)%
4      ,UT(30),TOS(30,48),TIS(30,48),G(30,30),TOY(48),DB(24)%
5      ,QLITX(24,3),QEQUX(24,3),QOCUP(24,3),QOCPS(24),QLITE(24)%
6      ,QEQU(24),QI(30),CR(30),NR(30),QGLAS(30,24),ITHSI,UENDW%
7      ,AZW(30),SHADE(30),RMDBS(24),RMDBW(24),SMD(30),UCELNG
8      DIMENSION AA(30,30),BB(30),TT(30),TIF(30),A2(30,30)%
9      ,B2(30),B3(30),GSUM(30),V(15)
10     TS=V(1)
11     CFML=V(2)
12     CFMS=V(3)
13     RROOM=V(4)
14     RCELG=V(5)
15     RROOML=V(12)
16     TIM=V(6)
17     QCMAX=V(7)
18     QHMAX=V(8)
19     TUL=V(9)
20     TLL=V(10)
21     TSET=V(11)
22     HR=V(13)
23     MET=V(14)
24     DBNX=DB(NX)-TIM
25     TU=TS-TIM
26     NEXP2=NEXP+1
27     DO 10 I=1,NEXP
28     BB(I)=0.
29     B2(I)=0.
30     DO 10 J=1,NEXP
31     A2(I,J)=0.
32     10   AA(I,J)=0.
33     SHG=0.
34     HSUM=0.
35     ASUM=0.
36     ASUMT=0.
37     DO 70 I=1,NEXP
38     NRR=NR(I)
39     SHG=SHG+QGLAS(I,NX)*A(I)
40     ASUMT=ASUMT+A(I)
41     GSUM(I)=0.
42     DO 20 J=1,NEXP
43     20   GSUM(I)=GSUM(I)+G(I,J)
44     IF (ITYPE(I).NE.3) ASUM=ASUM+A(I)
45     IF (MET.NE.0) GSUM(I)=HR
46     HSUM=HSUM+HI(I)*A(I)
47     IR=IRF(I)
48     CRX=CR(I)
49     IF (NRR.GE.2) GO TO 40
50     X(IR,1)=UT(I)

```



```

51      Y(IR,1)=UT(I)
52      CRX=0.
53      Z(IR,1)=UT(I)
54      40      AA(I,1)=X(IR,1)+HI(I)+GSUM(I)
55      DO 50 J=1,NEXP
56      IF (I.EQ.J) GO TO 50
57      AA(I,J)=-G(I,J)
58      50      CONTINUE
59      AA(I,NEXP2)=-HI(I)
60      SUMY=Y(IR,1)*TOS(I,1)
61      SUMX=0.
62      IF(NRR.LT.2) GO TO 61
63      DO 60 J=2,NRR
64      SUMY=SUMY+Y(IR,J)*TOS(I,J)
65      60      SUMX=SUMX+X(IR,J)*TIS(I,J)
66      61      CONTINUE
67      B3(I)=SUMY-CRX*QI(I)-SUMX
68      70      AA(NEXP2,I)=A(I)*HI(I)
69      IF(UENDW.EQ.0) GO TO 80
70      RCT=1./UCELNG-1./HI(I)
71      UCT=1./RCT
72      AA(1,1)=UCT+HI(1)+GSUM(1)
73      B3(1)=UCT*TOS(1,1)
74      80      CONTINUE
75      SHX=SHG/ASUM
76      QLTEMP=QLITE(NX)*(1-RCELG)*RROOML+(QOCPS(NX)+QEQUP(NX))*RROOM
77      QLX=QLTEMP/ASUMT
78      DO 90 I=1,NEXP
79      SHF=SHX
80      QLT=QLX
81      IF (ITYPE(I).EQ.3.OR.ITYPE(I).EQ.7) SHF=0.
82      IF (ITYPE(I).EQ.7) QLT=0.
83      90      BB(I)=B3(I)+SHF+QLT
84      AA(NEXP2,NEXP2)=-1.08*(CFML+CFMS)-HSUM
85      JK=1
86      NEXP3=NEXP2+1
87      DO 95 I=1,NEXP2
88      DO 95 J=1,NEXP2
89      95      A2(I,J)=AA(I,J)
90      SUM1=(QOCPS(NX)+QEQUP(NX))*(1.-RROOM)
91      SUM2=QLITE(NX)*(1.-RROOML)*(1.-RCELG)
92      SUM3=0.
93      SUM=1.08*(CFML*DBNX+CFMS*TU)+SUM1+SUM2
94      BB(NEXP2)=-SUM
95      IF(ITHST.NE.0.AND.ITK.EQ.0) GO TO 130
96      102      BB(NEXP2)=-SUM-SUM3
97      IF(MET.EQ.0) GO TO 91
98      SUM4=0.
99      SUM5=0.
100     DO 92 I=1,NEXP

```

```

101          SUM4=SUM4+(HI(I)*A(I)*BB(I))/AA(I,I)
102          SUM5=SUM5+HI(I)*A(I)*(HI(I)+HR)/AA(I,I)
103          92 CONTINUE
104          TT(NEXP2)=(SUM4-BB(NEXP2))/(-AA(NEXP2,NEXP2)-SUM5)
105          GO TO 94
106          91 CONTINUE
107          CALL SOLVP(NEXP2,NEXP3,AA,BB,TT,30)
108          94 TA=TT(NEXP2)+TIM
109          IF(ITHST.EQ.0.AND.ITK.EQ.1) GO TO 133
110          IF(JK.EQ.2) GO TO 133
111          GO TO 103
112          130 DO 100 I=1,NEXP2
113          100 B2(I)=BB(I)-AA(I,NEXP2)*(TA-TIM)
114          IF(MET.EQ.0) GO TO 131
115          DO 132 I=1,NEXP
116          TT(I)=((HI(I)+HR)*(TA-TIM)+BB(I))/AA(I,I)
117          132 CONTINUE
118          GO TO 133
119          131 CONTINUE
120          CALL SOLVP(NEXP,NEXP2,A2,B2,TT,30)
121          133 CONTINUE
122          QL=SUM-1.08*(CFML+CFMS)*(TA-TIM)
123          GO TO 140
124          103 IF(TA-TUL) 111,112,112
125          111 IF(TA-TLL) 114,114,133
126          112 TA=TUL
127          GO TO 130
128          114 TA=TLL
129          GO TO 130
130          140 SUMQ=0.
131          DO 160 I=1,NEXP
132          K=IRF(I)
133          TIS(I,1)=TT(I)
134          TEST=ABS(TT(I))
135          IF (TEST.GT.100.) GO TO 170
136          IF(ITYPE(I).EQ.10) X(K,1)=UT(I)
137          QI(I)=X(K,1)*TT(I)-B3(I)
138          IF (ITYPE(I).EQ.7) QI(I)=0.
139          IF (UENDW.NE.0..AND.ITYPE(I).EQ.1) QI(I)=UI(I)*(T(I)-TUS(1,1))
140          TIF(I)=TT(I)+TIM
141          IF (ITYPE(I).EQ.7) TIF(I)=TA
142          150 SUMQ=SUMQ+A(I)*HI(I)*(TA-TIF(I))
143          160 CONTINUE
144          QL=-QL+SUMQ
145          IF(ITHST.NE.0.OR.ITK.NE.0) GO TO 185
146          IF(JK.EQ.2) GO TO 185
147          IF(QL) 183,185,184
148          183 QLTEST=ABS(QL)
149          IF(QLTEST-QCMAX) 185,185,182
150          182 SUM3=-QCMAX

```

```
151         JK=2
152         GO TO 102
153     184     IF (QL-QHMAX) 185,185,186
154     186     SUM3=QHMAX
155         JK=2
156         GO TO 102
157     185     RETURN
158     170     CONTINUE
159         WRITE (6,190)
160         DO 180 I=1,NEXP2
161     180     WRITE(6,200) (A2(I,J),J=1,NEXP2),B2(I),I(I)
162         RETURN
163     %
164     %
165     %
166     190     FORMAT(' ERROR IN THE TMTMP ROUTINE: MATRIX ELEMENTS ARE LISTED FOR YOUR EXAMINATION%
167     IN THE FOLLOWING ORDER : AA(I,J),J=1,NEXP2,B(I),I(I)')
168     200     FORMAT(12 F10.3)
169     END
```

```

1  SUBROUTINE ROOMX(NEXP,NS,NW,NN,NE,H)
2      DIMENSION NEXP(4)
3      COMMON /CC/ X(10,100),Y(10,100),Z(10,100),ITYPE(30),IHT(30),IRF(30)
4      ,ARSP(30),U(30),HT(30),HI(30),A(30),V(30),TOS(30,48),TIS(30,48),G*
5      (30,30),TOY(48),DH(24),QLITX(24,3),QEQUX(24,3),QOCUP(24,3),QOCPS(2*
6      4),QLITF(24),QEQUP(24),QI(30),CR(30),NR(30),QGLAS(30,24),IHTST,UEH%
7      DW,AZW(30),SHADE(30),RMDRS(24),RMDRW(24),SHD(30),UCFLNG
8      REAI L,FS(6,6)
9      COMMON/SHOW/SHADW(30,15)
10     %
11     % *****
12     % * * *
13     % * * *
14     % * * *
15     % * * SOUTH FACING *
16     % (W) * * * WALL * (H)
17     % * * *
18     % *****
19     % (L)
20     %
21     %
22     % NS = NUMBER OF HEAT TRANSFER SURFACES IN THE SOUTH WALL
23     % NW = NUMBER OF HEAT TRANSFER SURFACES IN THE WEST WALL
24     % NN = NUMBER OF HEAT TRANSFER SURFACES IN THE NORTH WALL
25     % NE = NUMBER OF HEAT TRANSFER SURFACES IN THE EAST WALL
26     % NEXP = TOTAL NUMBER OF HEAT TRANSFER SURFACES = 2*NS+NW+NN+NE
26.2  WRITE(6,101)
26.3  101 FORMAT(' DATA SHEET NO 12: NS,NW,NN,NE,L,W,H')
27     READ(5,*)NEXP
28     NS=NEXP(1)
29     NW=NEXP(2)
30     NN=NEXP(3)
31     NE=NEXP(4)
32     NEXP=2*NS+NW+NN+NE
33     % L = ROOM LENGTH ALONG THE SOUTH WALL
34     % W = ROOM WIDTH ALONG THE WEST WALL
35     % H = ROOM CEILING HEIGHT
36     READ(5,*)L,W,H
37     CALL FCTR (L,W,H,FS)
38     NS=NS+1
39     NW=NW+1
40     NN=NN+1
41     NE=NE+1
42     AS=L*H
43     AW=W*H
44     AN=AS
45     AF=AW
46     AR=L*W
47     AF=AR
47.2  WRITE(6,111)

```

```

47.3 111 FORMAT(' DATA SHEET 13 AND 14: ROOM SURFACE DATA AND EXTERIOR SURFACE SHADOW DATA')
48    DO 10 I=1,NEXP
49    *   READ FOLLOWING DATA IN THE ORDER OF CEILING, SOUTH WALL, WEST
50    *   WALL, NORTH WALL, EAST WALL, FLOOR.
51    *   READ (5,*) ITYPE(I),IRF(I),A(I),AZW(1),U(1),SHADE(I),ABSP(I),SHD(I)
52    *   READ SHADOW INFORMATION
53    READ(5,*)(SHADW(I,J),J=1,7)
53.1  READ(5,*)(SHADW(I,J),J=8,15)
54    10  CONTINUE
55        DO 20 I=1,NEXP
56        IF (I.EQ.1) M=1
57        IF (I.GT.1.AND.I.LE.NS) M=2
58        IF (I.GT.NS.AND.I.LE.NW) M=3
59        IF (I.GT.NW.AND.I.LE.NN) M=4
60        IF (I.GT.NN.AND.I.LE.NE) M=5
61        IF (I.EQ.NEXP) M=6
62        DO 20 J=1,NEXP
63        IF (J.EQ.1) G(I,J)=FS(M,1)
64        IF (J.GT.1.AND.J.LE.NS) G(I,J)=FS(M,2)*A(J)/AS
65        IF (J.GT.NS.AND.J.LE.NW) G(I,J)=FS(M,3)*A(J)/AW
66        IF (J.GT.NW.AND.J.LE.NN) G(I,J)=FS(M,4)*A(J)/AN
67        IF (J.GT.NN.AND.J.LE.NE) G(I,J)=FS(M,5)*A(J)/AE
68        IF (J.EQ.NEXP) G(I,J)=FS(M,6)
69    20  CONTINUE
70    RETURN
71    END

```

```

1      SUBROUTINE SHADOW(SHDX,PHI,COSZ,SHRAT).
2      DIMENSION SHDX(20)
3      HT=SHDX(1)
4      FL=SHDX(2)
5      FP=SHDX(3)
6      AW=SHDX(4)
7      BWL=SHDX(5)
8      BWR=SHDX(6)
9      D=SHDX(7)
10     FP1=SHDX(8)
11     A1=SHDX(9)
12     B1=SHDX(10)
13     C1=SHDX(11)
14     FP2=SHDX(12)
15     A2=SHDX(13)
16     B2=SHDX(14)
17     C2=SHDX(15)
18     WAZI=SHDX(16)
19     % THIS PROGRAM CALCULATES SHADOW CAST BY OVERHUNG AND SIDE FINS
20     % THIS PROGRAM HAS BEEN DEVELOPED BY TSENG-YAO SUN
21     % PHI....SOLAR AZIMUTH ANGLE
22     % COSZ...COSINE OF SOLAR ZENITH ANGLE
23     % SHRAT..SHADE RATIO:RATIO OF THE SUNLIT AREA TO THE TOTAL WINDOW AREA
24     % HT.....WINDOW HEIGHT
25     % FL.....WINDOW WIDTH
26     % FP.....DEPTH OF THE OVERHUNG
27     % AW.....DISTANCE FROM TOP OF THE WINDOW TO THE OVERHUNG
28     % BWL....DISTANCE OF THE OVERHUNG EXTENDED BEYOND THE LEFT EDGE OF THE WINDOW
29     % BWR....DISTANCE OF THE OVERHUNG EXTENDED BEYOND THE RIGHT EDGE OF THE WINDOW
30     % D.....DEPTH OF VERTICAL PROJECTION AT THE END OF THE OVERHUNG
31     % FP1....DEPTH OF THE LEFT FIN
32     % A1.....DISTANCE OF THE LEFT FIN EXTENDED ABOVE THE TOP OF THE WINDOW
33     % B1.....DISTANCE FROM THE LEFT EDGE OF THE WINDOW TO THE LEFT FIN
34     % C1.....DISTANCE OF THE LEFT FIN STOP SHORT ABOVE THE BOTTOM OF THE WINDOW
35     % FP2....DEPTH OF THE RIGHT FIN
36     % A2.....DISTANCE OF THE RIGHT FIN EXTENDED ABOVE THE TOP OF THE WINDOW
37     % B2.....DISTANCE FROM THE RIGHT EDGE OF THE WINDOW TO THE RIGHT FIN
38     % C2.....DISTANCE OF THE RIGHT FIN STOP SHORT ABOVE THE BOTTOM OF THE WINDOW
39     % WAZI...WINDOW AZIMUTH ANGLE
40     SHRAT=1.
41     1103 A=AW
42         H=HT
43         GAMMA=PHI-WAZI
44         COSG=COS(GAMMA)
45         IF(COSG)100,100,104
46     100 SHRAT=0.
47         GO TO 2000
48     104 CONTINUE
49         SBETA=COSZ
50         IF(SBETA)100,100,152

```



```

51      152  SING=SIN(GAMMA)
52      VERT=SBETA/SQRT(1.-SBETA*SBETA)/COSG
53      HORIZ=ABS(SING)/COSG
54      TCETA=VERT/HORIZ
55      IF(GAMMA) 155,154,154
56      % -----SUN ON LEFT
57      154  B=BWL
58      GO TO 156
59      % -----SUN ON RIGHT
60      155  B=BWR
61      156  ARSHF=0.
62      AREA V=0.
63      ARSIF=0.
64      AREA0=0.
65      AREA1=0.
66      ARSH1=0.
67      FL3=0.
68      H3=0.
69      H1=H
70      FL1=FL
71      K=1
72      L=1
73      T1=FP*VERT
74      FM1=FP*HORIZ
75      IF(FP) 37,37,153
76      153  T=T1
77      FM=FM1
78      AB=B*TCETA
79      UG=(FL+B)*TCETA
80      DE=(H+A)/TCETA
81      % -----HORIZONTAL OVERHUNG "AREA0"
82      IF(T-A) 27,27,2
83      2    IF(AB-A) 14,14,3
84      3    IF(DE-B) 12,12,4
85      4    IF(FM-B) 11,11,5
86      5    IF(DE-(FL+B)) 8,8,6
87      6    IF(FM-(FL+B)) 9,7,7
88      % -----HORIZ 9
89      7    AREA0=FL*(0.5*(AB+UG)-A)
90      GO TO 37
91      8    IF(T-(H+A)) 9,10,10
92      % -----HORIZ 7
93      9    AREA0=(T-A)*FL-((FM-B)**2)*TCETA*0.5
94      L=2
95      GO TO 21
96      % -----HORIZ 8
97      10   AREA0=H*FL-(DE-B)**2*TCETA*0.5
98      GO TO 37
99      % -----HORIZ 3
100     11   AREA0=FL*(T-A)

```

```

101          L=2
102          GO TO 24
103          12  IF(T-(H+A)) 11,13,13
104          %  -----HORIZ 2
105          13  AREA0=H*FL
106          GO TO 68
107          14  IF(UG-A)27,27,15
108          15  IF(DE-(FL+B))18,18,16
109          16  IF(FM-(FL+B))20,17,17
110          %  -----HORIZ 6
111          17  AREA0=(UG-A)**2/TCETA*0.5
112          GO TO 37
113          18  IF(T-(H+A))20,19,19
114          %  -----HORIZ 5
115          19  AREA0=H*(FL-(A+0.5*H)/TCETA+B)
116          GO TO 37
117          %  -----HORIZ 4
118          20  AREA0=(T-A)*(FL+B-FM*(1.+A/T)*0.5)
119          L=2
120          %  -----VERT PROJ "AREAV"
121          21  FL3=FL+B-FM
122          IF(T+D-(H+A))22,22,23
123          %  -----VERT 8
124          22  H3=D
125          GO TO 3700
126          %  -----VERT 9
127          23  H3=H+A-T
128          GO TO 3700
129          24  FL3=FL
130          IF(T+D-(H+A))26,26,25
131          %  -----VERT 7
132          25  H3=H+A-T
133          AREAV=H3*FL3
134          GO TO 68
135          %  -----VERT 6
136          26  H3=D
137          GO TO 3700
138          27  IF(T+D-A)37,37,28
139          28  IF(FM-B)34,34,29
140          29  IF(FM-(FL+B))31,37,37
141          31  FL3=FL+B-FM
142          IF(T+D-(H+A))33,33,32
143          %  -----VERT 5
144          32  H3=H
145          GO TO 3700
146          %  -----VERT 4
147          33  H3=T+D-A
148          GO TO 3700
149          34  IF(T+D-(H+A))36,35,35
150          %  -----VERT 2

```

```

151      35      AREAV=H*FL
152      GO TO 68
153      %      VERT 3
154      36      H3=T+D-A
155      FL3=FL
156      3700    AREAV=FL3*H3
157      %      -----SIDE FIN AND SHORT SIDE FIN
158      %      -----SIDE FIN "AREA1" "ARSIF"
159      37      IF(GAMMA)66,68,74
160      74      FPF=FP1
161      AF=A1
162      BF=B1
163      CX=C1
164      GO TO 84
165      66      FPF=FP2
166      AF=A2
167      BF=B2
168      CX=C2
169      84      IF(FPF)68,68,67
170      67      T=FPF*VERT
171      FM=FPF*HORIZ
172      AF1=AF
173      IF(AREA0)73,73,88
174      %      -----TEST FOR OVERLAP OF FIN AND OVERHUNG SHADOW
175      88      AT=A+(BF-B)*TCETA
176      IF(AT-AF)711,73,73
177      %      -----OVERLAP EXISTS..L=2 IF OVERHUNG SHADOW HAS HORIZ EDGE IN WINDOW
178      711     GO TO(621,712),L
179      %      -----TEST FOR TYPE OF OVERLAP
180      712     IF((FM-BF)-(FM1-B))621,622,622
181      %      -----SET L=1,SHADOW INTERSECT ON INCLINED EDGE OF OVERHUNG SHADOW
182      %      -----FIN SHADOW IS BELOW INCLINED EDGE OF OVERHUNG SHADOW
183      621     AF=AT
184      L=1
185      GO TO 73
186      %      -----L IS 2, HORIZ EDGE OF OVERHUNG SHADOW-PORTION ABOVE HORIZ EDGE
187      %      -----NOT IN OVERHUNG SHADOW IS FIN SHADOW
188      622     AREA1=FL*(T1-A)-AREA0
189      %      -----RESET TO CALC FIN SHADOW BELOW HORIZ EDGE OF OVHNG SHADOW
190      AF=T1-A+AF1
191      H=H+AF1-AF
192      %      -----SHADOW OF FIN (K=1 ON GLASS K=2 ON VERT PROJ SHADOW)
193      73      AB=BF*TCETA
194      UG=(FL+BF)*TCETA
195      DE=(H+AF)/TCETA
196      DJ=CX/TCETA
197      IF(FM-BF)69,69,38
198      38      IF(AB-AF)39,50,50
199      39      IF(UG-AF)48,48,40
200      40      IF(T-AF)47,47,41

```

```

201      41      IF (UG-(H*AF))44,44,42
202      42      IF (T-(H*AF))91,80,80
203      %      -----FIN 9
204      80      AREA1=H*((AF+H*0.5)/TCETA-BF)+AREA1
205      GO TO 58
206      44      IF (FM-(FL+BF))91,89,89
207      %      -----FIN8
208      89      AREA1=H*FL-(UG-AF)**2/TCETA*0.5+AREA1
209      GO TO 58
210      %      -----FIN 7
211      91      AREA1=(FM-BF)*H-(T-AF)**2/TCETA*0.5+AREA1
212      GO TO 63
213      48      IF (FM-(FL+BF))47,47,49
214      %      -----FIN 3
215      47      AREA1=H*(FM-BF)+AREA1
216      GO TO 63
217      %      -----FIN 2
218      49      AREA1=H*FL+AREA1
219      GO TO 58
220      50      IF (DE-BF)69,69,51
221      51      IF (UG-(H*AF))55,55,52
222      52      IF (T-(H*AF))93,94,94
223      %      -----FIN 6
224      94      AREA1=(DE-BF)**2*TCETA*0.5+AREA1
225      GO TO 58
226      %      -----FIN 4
227      93      AREA1=(FM-BF)*(H*AF-(T+AB)*0.5)+AREA1
228      GO TO 63
229      55      IF (FM-(FL+BF))93,99,99
230      %      -----FIN 5
231      99      AREA1=FL*(H-(BF+FL*0.5)*TCETA+AF)+AREA1
232      %      -----SHORT SIDE FIN "ARSH1","ARSHF"
233      58      IF (DJ-BF)69,69,59
234      59      IF (DJ-(FL+BF))61,61,60
235      %      -----SHORT 3
236      60      ARSH1=-FL*(CX-(BF+FL/2.)*TCETA)
237      GO TO 69
238      %      -----SHORT 4
239      61      ARSH1=-(CX-AB)**2/TCETA*0.5
240      GO TO 69
241      63      IF (DJ-BF)69,69,64
242      64      IF (DJ-FM)61,61,65
243      %      -----SHORT 2
244      65      ARSH1=-(FM-BF)*(CX-(T+AB)*0.5)
245      69      GO TO (77,76),K
246      76      ARSH1=-ARSH1
247      AREA1=-AREA1
248      77      ARSHF=AKSHF+ARSH1
249      ARSIF=AKSIF+AREA1
250      GO TO(78,68),K

```

```

251      78      IF (AREAV) 68,68,72
252      %      -----RESET PARAMETERS TO DEDUCCT FIN SHADOW OVERLAP ON VERT PROJ SHADOW
253      72      K=2
254          AREA1=0.
255          ARSH1=0.
256          BBF=BF
257          BF=FM1-B+BF
258          IF (BF) 186,185,185
259          186      BF=BBF
260          185      IF (HT+A-T1-D) 87,87,188
261          188      CX=CX-(HT+A-T1-D)
262          IF (CX) 85,87,87
263          85      CX=0.
264          87      AF=T1-A+AF
265          H=H3
266          FL=FL3
267          GO TO 73
268          %      ----- SHADED AREA "ARSHA"
269          68      ARSHA=AREAU+AREAV+ARSHF+ARSIF
270          SHRAT=(FL1*H1-ARSHA)/(FL1*H1)
271          FL=FL1
272          2000     CONTINUE
273          RETURN
274          END

```

```

1      SUBROUTINE SHG (SH)
2      DIMENSION SH(20)
3
4      % SH(1)=INTENSITY OF DIRECT NORMAL SOLAR RADIATION
5      % SH(2)=INTENSITY OF DIFFUSE SKY RADIATION
6      % SH(3)=INTENSITY OF GROUND REFLECTED DIFFUSE RADIATION
7      % SH(4)=COSINE OF INCIDENCE OF DIRECT SOLAR RADIATION
8      % SH(5)=FORM FACTOR BETWEEN THE WINDOW AND THE SKY
9      % SH(6)=FORM FACTOR BETWEEN THE WINDOW AND THE GROUND
10     % SH(7)=THERMAL RESISTANCE AT OUTSIDE SURFACE
11     % SH(8)=THERMAL RESISTANCE AT THE AIR SPACE (DOUBLE GLAZING)
12     % SH(9)=THERMAL RESISTANCE AT THE INNER SURFACE
13     % SH(10)=SUNLIT AREA FACTOR
14     % SH(11)=SHADING COEFFICIENT ,NON-ZERO VALUE WILL BE GIVEN ONLY
15     % WHEN THE WINDOW IS SHADED BY DRAPES OR BLINDS OR IF IT HAS
16     % AN INTERPANE SEPARATION OF MORE THAN 1-INCH
17     % SH(12)=TRANSMISSION FACTOR FOR DIRECT RADIATION
18     % SH(13)=TRANSMISSION FACTOR FOR DIFFUSE RADIATION
19     % SH(14)=ABSORPTION FACTOR FOR DIRECT RADIATION (OUTER PANE)
20     % SH(15)=ABSORPTION FACTOR FOR DIRECT RADIATION (INNER PANE)
21     % SH(16)=ABSORPTION FACTOR FOR DIFFUSE RADIATION(OUTER PANE)
22     % SH(17)=ABSORPTION FACTOR FOR DIFFUSE RADIATION(INNER PANE)
23     % SH(18)=SOLAR HEAT GAIN
24     COMMON /SOL/ LAT, LONG, TZN, WAZ, WT, CN, DST, LPYR, S(35)
25     REAL LAT, LONG, NI, NO
26     NI=(SH(7)+SH(8))/(SH(7)+SH(8)+SH(9))
27     NO=(SH(7))/(SH(7)+SH(8)+SH(9))
28     D=SH(10)*SH(1)*SH(4)*(SH(12)+NO*SH(14)+NI*SH(15))
29     DD=(SH(2)*SH(5)+SH(3)*SH(6))*(SH(13)+NO*SH(16)+NI*SH(17))
30     IF (SH(11)) 20,10,20
31     10 SH(18)=D+DD
32     GO TO 30
33     20 SH(18)=(D+DD)*SH(11)
34     30 RETURN
35     END

```



```
1          SUBROUTINE SOLVP (M,N,C,D,X,1)
2          % THIS IS A ROUTINE FOR SOLVING SIMULTANEOUS LINEAR EQUATIONS
3          % THE ROUTINE WAS DEVELOPED BY B.A. PEAVY OF NBS
4          % ROUTINE FAILS WHEN ANY OF THE DIAGONAL ELEMENTS IS ZERO
5          DIMENSION A(100,101),C(1,1),D(1),X(1)
6          DO 10 IX=1,M
7          DO 10 IY=1,M
8          10  A(IX,IY)=C(IX,IY)
9          DO 20 IZ=1,M
10         20  A(IZ,N)=D(IZ)
11         L=1
12         30  AA=A(L,L)
13         DO 40 K=L,N
14         40  A(L,K)=A(L,K)/AA
15         DO 60 K=1,M
16         IF (K.EQ.L) GO TO 60
17         AA=-A(K,L)
18         DO 50 IA=L,N
19         50  A(K,IA)=A(K,IA)+AA*A(L,IA)
20         60  CONTINUE
21         L=L+1
22         IF (L.LE.M) GO TO 30
23         DO 70 IP=1,M
24         70  X(IP)=A(IP,N)
25         RETURN
26         END
```

```

1      SUBROUTINE SUN
2      DIMENSION A0(5)/.302,-.0002,368.44,.1717,0.0905/,A1(5)/-22.93,.419%
3      7, 24.52,-.0344,-.0410/,A2(5)/-.229,-3.2265,-1.14,.0032,.0073/,A3(5%
4      )/-.243,-.0903,-1.09,.0024,.0015/,B1(5)/3.851,-7.351,.58,-.0043,-.%
5      0034/,B2(5)/.002,-9.3912,-.18,0.,0.0004/,B3(5)/-.055,-.3361,.28,-.%
6      0008,-.0006/
7      REAL LAT,LATD,LONG,MERID,LOND
8      COMMON /SOL/ LAT,LONG,TZN,WAZ,WT,CN,DST,LPYR,S(35)
9      % S(1)= LATITUDE,DEGREES(+NORTH,-SOUTH)
10     % S(2)= LONGITUDE,DEGREES(+WEST,-EAST)
11     % S(3)= TIME_ZONE NUMBER
12     % STANDARD TIME DAYLIGHT SAVING TIME
13     % ATLANTIC 4 3
14     % EASTERN 5 4
15     % CENTRAL 6 5
16     % MOUNTAIN 7 6
17     % PACIFIC 8 7
18     % S(4)= DAYS(FROM START OF YEAR)
19     % S(5)= TIME,HOUR AFTER MIDNIGHT)
20     % S(6)= DAYLIGHT SAVING TIME INDICATOR
21     % S(7)= GROUND REFLECTIVITY
22     % S(8)= CLEARNESS NUMBER
23     % S(9)= WALL AZIMUTH ANGLE, DEGREES FROM SOUTH
24     % S(10)=WALL TILT ANGLE, DEGREES FROM HORIZON
25     % S(11)=SUN RISE TIME (HOURS AFTER MIDNIGHT)
26     % S(12)=SUN SET TIME
27     % S(13)=COSZ DIRECTION COSINES
28     % S(14)=COSN DIRECTION COSINES
29     % S(15)=COS(S) DIRECTION COSINES)
30     % S(16)=ALPHA DIRECTION COSINES NORMAL TO SURFACE
31     % S(17)=BETA
32     % S(18)=GAMMA
33     % S(19)=COS(ETA)COSINE OF INCIDENCE ANGLE
34     % S(20)=SOLAR ALTITUDE ANGLE
35     % S(21)=SOLAR AZIMUTH ANGLE
36     % S(22)=DIFFUSE SKY RADIATION ON HORIZONTAL SURFACE
37     % S(23)=DIFFUSE GROUND REFLECTED RADIATION
38     % S(24)=DIRECT NORMAL RADIATION
39     % S(25)=TOTAL SOLAR RADIATION INTENSITY
40     % S(26)=DIFFUSE SKY RADIATION INTENSITY
41     % S(27)=GROUND REFLECTED DIFFUSE RADIATION INTENSITY
42     % S(28)=SUN DECLINATION ANGLE,DEGREES
43     % S(29)=EQUATION OF TIME ,HOURS
44     % S(30)=A SOLAR FACTOR
45     % S(31)= SOLAR FACTOR
46     % S(32)= SOLAR FACTOR
47     % S(33)= CLOUD COVER MODIFIER
48     % S(34) INTENSITY OF DIRECT SOLAR RADIATION ON SURFACE
49     % S(35) HOUR ANGLE,DEGREE
50     PI=3.1415927

```

```

51      X=2*PI/366.*S(4)
52      C1=COS(X)
53      C2=COS(2*X)
54      C3=COS(3*X)
55      S1=SIN(X)
56      S2=SIN(2*X)
57      S3=SIN(3*X)
58      DO 10 K=1,5
59      KS=(K-1)+28
60      10  S(KS)=A0(K)+A1(K)*C1+A2(K)*C2+A3(K)*C3+B1(K)*S1+B2(K)*S2+B3(K)*S3
61      S(29)=S(29)/60.
62      LATD=S(1)
63      LONG=S(2)
64      MERID=15*S(3)
65      LOND=LONG-MERID
66      Y=S(28)*PI/180.
67      YY=LATD*PI/180.
68      HP=-TAN(Y)*TAN(YY)
69      TR=12/PI*ACOS(HP)
70      S(11)=(12-TR)-S(29)+LOND/15.
71      S(12)=24.-S(11)
72      H=15*(S(5)-12+S(3)+S(29)-S(6))-S(2)
73      S(35)=H
74      S13=SIN(YY)*SIN(Y)+COS(YY)*COS(Y)*COS(H*PI/180.)
75      S(13)=S13
76      HP1=180.*ACOS(HP)/PI
77      X1=ABS(HP1)
78      X2=ABS(H)
79      IF (X1-X2) 130,20,20
80      20  S(14)=COS(Y)*SIN(H*PI/180.)
81      S(15)=SQRT(1.-S(13)*S(13)-S(14)*S(14))
82      STEST=S(15)
83      STEST1=COS(H*PI/180.)-TAN(Y)/TAN(YY)
84      IF (STEST1) 40,30,30
85      30  S(15)=STEST
86      GO TO 50
87      40  S(15)=-STEST
88      50  S(20)=ASIN(S(13))
89      IF (S(15)) 70,60,60
90      60  S(21)=ASIN(S(14)/COS(S(20)))
91      GO TO 80
92      70  S(21)=PI-ASIN(S(14)/COS(S(20)))
93      80  S(20)=180.*S(20)/PI
94      S(21)=180.*S(21)/PI
95      IF(S(21)-180.) 81,81,82
96      82  S(21)=360.-S(21)
97      81  CONTINUE
98      S(24)=S(30)*S(8)*S(33)*EXP(-S(31)/S(13))
99      S(22)=S(32)*S(24)/S(8)/S(8)
100     S(23)=S(7)*(S(22)+S(24)*S(13))

```

```
101          WY=S(10)*PI/180.
102          S(16)=COS(WY)
103          WA=S(9)*PI/180.
104          S(16)=COS(WY)
105          S(17)=SIN(WA)*SIN(WY)
106          S(18)=COS(WA)*SIN(WY)
107          S(19)=S(16)*S(13)+S(17)*S(14)+S(18)*S(15)
108          S(34)=S(24)*S(19)
109          Y=0.45
110          IF (S(19)+0.2) 100,100,90
111          90      Y=0.55+0.437*S(19)+0.313*S(19)**2
112          100      IF (S(19)) 110,110,120
113          110      S(19)=0.
114          110      S(34)=0.
115          120      CONTINUE
116          S(26)=S(22)*Y
117          S(27)=S(23)*(1-S(16))/2.
118          S(25)=S(34)+S(26)+S(27)
119          GO TO 150
120          130      DO 140 J=14,26
121          140      S(J)=0.
122          140      S(34)=0
123          150      RETURN
124          END
```

```

1      SUBROUTINE TAR (TR)
2      REAL A1(6)/0.01154,0.77674,-3.94657,8.57881,-8.38135,3.01188/
3      REAL A2(6)/0.01636,1.40783,-6.79030,14.37378,-13.83357,4.92439/
4      REAL A3(6)/0.01837,1.92497,-8.89134,18.40197,-17.48648,6.17544/
5      REAL A4(6)/0.01902,2.35417,-10.4715,21.24322,-19.95978,6.99964/
6      REAL A5(6)/0.01712,3.50839,-13.8639,26.34330,-23.84846,8.17372/
7      REAL A6(6)/0.01406,4.15958,-15.0628,27.18492,-23.88518,8.03650/
8      REAL A7(6)/0.01153,4.55946,-15.4329,26.70568,-22.87993,7.57195/
9      REAL A8(6)/0.00962,4.81911,-15.4714,25.86516,-21.69106,7.08714/
10     REAL T1(6)/-0.00885,2.71235,-0.62062,-7.07329,9.75995,-3.89922/
11     REAL T2(6)/-0.01114,2.39371,0.42978,-8.98262,11.51798,-4.52064/
12     REAL T3(6)/-0.01200,2.13036,1.13833,-10.07925,12.44161,-4.83285/
13     REAL T4(6)/-0.01218,1.90950,1.61391,-10.64872,12.83698,-4.95199/
14     REAL T5(6)/-0.01056,1.29711,2.28615,-10.37132,11.95884,-4.54880/
15     REAL T6(6)/-0.00835,0.92766,2.15721,-8.71429,9.87152,-3.73328/
16     REAL T7(6)/-0.00646,0.68256,1.82499,-6.95325,7.80647,-2.94454/
17     REAL T8(6)/-0.00496,0.51043,1.47607,-5.41985,6.00546,-2.28162/
18     REAL A01(6)/0.01407,1.06226,-5.59131,12.15034,-11.78092,4.20070/
19     REAL A02(6)/0.01819,1.86277,-9.24831,19.49443,-18.56094,6.53940/
20     REAL A03(6)/0.01905,2.47900,-11.7427,24.14037,-22.64299,7.89954/
21     REAL A04(6)/0.01862,2.96400,-13.4870,27.13020,-25.11877,8.68895/
22     REAL A05(6)/0.01423,4.14384,-16.66709,31.30484,-27.81955,9.36959/
23     REAL A06(6)/0.01056,4.71447,-17.33454,30.91781,-26.63898,8.79495/
24     REAL A07(6)/0.00819,5.01768,-17.21228,29.46388,-24.76915,8.05040/
25     REAL A08(6)/0.00670,5.18781,-16.84820,27.90292,-22.99619,7.38140/
26     REAL A11(6)/0.00228,0.34559,-1.19908,2.22336,-2.05287,0.72376/
27     REAL A12(6)/0.00123,0.29788,-0.92256,1.58171,-1.40040,0.48316/
28     REAL A13(6)/0.00061,0.26017,-0.72713,1.14950,-0.97138,0.32705/
29     REAL A14(6)/0.00035,0.22974,-0.58381,0.84626,-0.67666,0.22102/
30     REAL A15(6)/-0.00009,0.15049,-0.27590,0.25618,-0.12919,0.02859/
31     REAL A16(6)/-0.00016,0.10579,-0.15035,0.06487,0.02759,-0.02317/
32     REAL A17(6)/-0.00015,0.07717,-0.09059,0.00050,0.06711,-0.03394/
33     REAL A18(6)/-0.00012,0.05746,-0.05878,-0.01855,0.06837,-0.03191/
34     REAL TD1(6)/-0.00401,0.74050,7.20350,-20.11763,19.68824,-6.74585/
35     REAL TD2(6)/-0.00438,0.57818,7.42065,-20.26848,19.79706,-6.79619/
36     REAL TD3(6)/-0.00428,0.45757,7.41367,-19.92004,19.40969,-6.66603/
37     REAL TD4(6)/-0.00401,0.36698,7.27324,-19.29364,18.75408,-6.43968/
38     REAL TD5(6)/-0.00279,0.16468,6.17715,-15.84811,15.28302,-5.23666/
39     REAL TD6(6)/-0.00192,0.08180,4.94753,-12.43481,11.92495,-4.07787/
40     REAL TD7(6)/-0.00136,0.04419,3.87529,-9.59069,9.16022,-3.12776/
41     REAL TD8(6)/-0.00098,0.02576,3.00400,-4.33834,6.98747,-2.38328/
42     DIMENSION TR(9),A(8,6),T(8,6),A0(8,6),AI(8,6),TD(8,6)
43     % TR(1)= TRANSMISSION FACTOR ,DIRECT
44     % TR(2)= TRANSMISSION FACTOR ,DIFFUSE
45     % TR(3)= ABSORPTION FACTOR ,DIRECT, OUTER
46     % TR(4)= ,DIFFUSE, OUTER
47     % TR(5)= ,DIRECT, INNER
48     % TR(6)= ,DIFFUSE, INNER
49     % TR(7)= COSINE OF INCIDENT ANGLE
50     % TR(8)= TYPE OF GLASS

```

```

51      %      TR(9)=ID      CODE FOR THE GLAZING
52      %      ID   =1      SINGLE  GLAZING
53      %      ID   =2      DOUBLE  GLAZING
54      DO 10 J=1,6
55      A(1,J)=A1(J)
56      A(2,J)=A2(J)
57      A(3,J)=A3(J)
58      A(4,J)=A4(J)
59      A(5,J)=A5(J)
60      A(6,J)=A6(J)
61      A(7,J)=A7(J)
62      A(8,J)=A8(J)
63      T(1,J)=T1(J)
64      T(2,J)=T2(J)
65      T(3,J)=T3(J)
66      T(4,J)=T4(J)
67      T(5,J)=T5(J)
68      T(6,J)=T6(J)
69      T(7,J)=T7(J)
70      T(8,J)=T8(J)
71      AO(1,J)=AO1(J)
72      AO(2,J)=AO2(J)
73      AO(3,J)=AO3(J)
74      AO(4,J)=AO4(J)
75      AO(5,J)=AO5(J)
76      AO(6,J)=AO6(J)
77      AO(7,J)=AO7(J)
78      AO(8,J)=AO8(J)
79      AI(1,J)=AI1(J)
80      AI(2,J)=AI2(J)
81      AI(3,J)=AI3(J)
82      AI(4,J)=AI4(J)
83      AI(5,J)=AI5(J)
84      AI(6,J)=AI6(J)
85      AI(7,J)=AI7(J)
86      AI(8,J)=AI8(J)
87      TD(1,J)=TD1(J)
88      TD(2,J)=TD2(J)
89      TD(3,J)=TD3(J)
90      TD(4,J)=TD4(J)
91      TD(5,J)=TD5(J)
92      TD(6,J)=TD6(J)
93      TD(7,J)=TD7(J)
94      10      TD(8,J)=TD8(J)
95      ETA=TR(7)
96      L=TR(8)
97      ID=TR(9)
98      IF (ID.EQ.2) GO TO 30
99      TR(1)=T(L,1)
100     TR(2)=T(L,1)/2.

```



```

101      TR(3)=A(L,1)
102      TR(4)=A(L,1)/2.
103      DO 20 J=2,6
104      TR(1)=TR(1)+T(L,J)*(ETA**(J-1))
105      TR(2)=TR(2)+T(L,J)/(J+1)
106      TR(3)=TR(3)+A(L,J)*(ETA**(J-1))
107      20  TR(4)=TR(4)+A(L,J)/(J+1)
108      TR(5)=0
109      TR(6)=0
110      GO TO 50
111      30  TR(1)=TD(L,1)
112      TR(2)=TD(L,1)/2.
113      TR(3)=AO(L,1)
114      TR(4)=AO(L,1)/2.
115      TR(5)=AI(L,1)
116      TR(6)=AI(L,1)/2.
117      DO 40 J=2,6
118      X=ETA**(J-1)
119      TR(1)=TR(1)+TD(L,J)*X
120      TR(2)=TR(2)+TD(L,J)/(J+1)
121      TR(3)=TR(3)+AO(L,J)*X
122      TR(4)=TR(4)+AO(L,J)/(J+1)
123      TR(5)=TR(5)+AI(L,J)*X
124      40  TR(6)=TR(6)+AI(L,J)/(J+1)
125      50  TR(2)=2*TR(2)
126      TR(4)=2*TR(4)
127      TR(6)=2*TR(6)
128      RETURN
129      END

```

TEMPSH-PNC

PAGE 1

```
1      SUBROUTINE TEMPSH(MONTH,JJ,NK,RMDBS,RMDBW,RMDBWO,RMDBSO,TA)
2      DIMENSION RMDBS(24),RMDBW(24)
3      IF(MONTH.GE.6.AND.MONTH.LE.9) GO TO 6
4      IF(JJ.GT.1) GO TO 7
5      TA=RMDBW(NK)
6      GO TO 10
7      TA=RMDBWO
8      GO TO 10
9      IF(JJ.GT.1) GO TO 5
10     TA=RMDBS(NK)
11     GO TO 10
12     TA=RMDBSO
13     CONTINUE
14     RETURN
15     END
16
```

TEMPSH-PNC

PAGE 1

```
1          FUNCTION WBF (H,PB)
2          % THIS PROGRAM APPROXIMATES THE WET-BULB TEMPERATURE WHEN
3          % ENTHALPY IS GIVEN
4          IF (H) 20,20,5
5          CONTINUE
6          Y=LOG(H)
7          IF (H.GT.11.758) GO TO 10
8          WBF=0.6041+3.4841*Y+1.3601*Y*Y+0.97307*Y*Y*Y
9          GO TO 90
10         WBF=30.9185-39.68200*Y+20.5841*Y*Y-1.758*Y*Y*Y
11         GO TO 90
12         WBI=150.
13         PV1=PVSF(WBI)
14         W1=0.622*PV1/(PB-PV1)
15         X1=0.24*WBI+(1061+0.444*WBI)*W1
16         Y1=H-X1
17         WBI=WBI-1
18         PV2=PVSF(WBI)
19         W2=0.622*PV2/(PB-PV2)
20         X2=0.24*WBI+(1061+0.444*WBI)*W2
21         Y2=H-X2
22         IF (Y1*Y2) 80,50,40
23         WBI=WBI
24         Y1=Y2
25         GO TO 30
26         WBI=WBI
27         WBF=WBI
28         GO TO 90
29         WBI=WBI
30         GO TO 90
31         Z=ABS(Y1/Y2)
32         WBF=(WBI*Z+WBI)/(1+Z)
33         RETURN
34         END
```

```
1          SUBROUTINE WD(INPUT)
2          INTEGER INPUT(1100),INCM(83)
3          COMMON NRUN,ISKIP,VOL(2),DENS,PARITY,TRACK
4          DATA TST/0./
5          LEN=83
6          IF(NRUN.NE.0) GO TO 42
7          IF(DENS.EQ.' ') GO TO 42
8          CALL TPROP(INCM,LEN,STATUS,VOL,DENS,PARITY,TRACK)
9          GO TO 41
10         42 CONTINUE
11         IF(DENS.NE.' ') GO TO 70
12         READ(1) INCM
13         GO TO 40
14         70 CONTINUE
15         CALL TPRRD(INCM,LEN,STATUS,VOL)
16         41 IF(STATUS.EQ.TST) GO TO 40
17         WRITE(6,50)
18         50 FORMAT(' TAPE ERROR')
19         STOP
20         40 CONTINUE
21         NRUN=NRUN+1
22         IF(NRUN.LT.ISKIP) GO TO 42
23         DO 30 J=1,LEN
24             DO 30 K=1,6
25                 JJ=(K-1)*6
26                 JK=(J-1)*6+K
27         30 INPUT(JK)=FLD(JJ,6,INCM(J))
28         RETURN
29         END
```

```
1          SUBROUTINE WDX(IW)
2          DIMENSION IDATA(10)/012,01,02,03,04,05,06,07,010,011/,JDATA(10)/072%
3          ,061,062,063,064,065,066,067,070,071/,KDATA(10)/052,041,042,043,044%
4          ,045,046,047,050,051/
5          DATA KX/040/
6          DO 50 KK=1,10
7          IF(IW.EQ.IDATA(KK)) GO TO 60
8          IF(IW.EQ.JDATA(KK)) GO TO 60
9          IF(IW.EQ.KDATA(KK)) GO TO 61
10         50 CONTINUE
11         IF(IW.EQ.KX) GO TO 62
12         IW=1000000
13         GO TO 40
14         60 IW=KK-1
15         GO TO 40
16         61 IW=-(KK-1)
17         GO TO 40
18         62 IW=10
19         40 RETURN
20         END
```

```

1      %      THIS PROGRAM DECODES WEATHER TAPE 144 AND CREATE A BINARY TAPE%
2      %      ,WHICH IS USEFUL FOR THE LOAD CALCULATION PROGRAM NBSLD
3      DIMENSION DB(24),DPT(24),WBT(24),WST(24),PBT(24),IC(24),NTOC(24)
4      INTEGER WPOS(10)/13,11,16,19,22,34,43,46,68,70/,WLONG(10)/3,2,3, %
5      3,4,1,1,2,3/,OUTPUT(24,10),DAY,CITY,YEAR,DAYSKP,INPUT(1100)
6      COMMON NRUN,DAYSKP,VOL(2),DENS,PARITY,TRACK
7      READ(5,200,PROMPT=' VOL,DENS,PARITY,TRACK:')VOL,DENS,PARITY,TRACK
8      200    FORMAT(5A4)
9      NRUN=0
10     WRITE(6,92)
11     92    FORMAT(' ISKIP NDAY IWRITE')
12     READ(5,*) ISKIP,NDAY,IWRITE
13     DAYSKP=ISKIP*4
14     CALL WDNEW(INPUT)
15     DO 102 I=1,NDAY
16     CALL DECODH(WPOS,WLONG,10,OUTPUT,0,YEAR,MONTH,DAY,CITY)
17     3     DO 2 K=1,10
18     2     CALL ERROR(OUTPUT(1,K),K)
19     IF(I.GT.1) GO TO 199
20     WRITE(6,4)
21     WRITE(6,5)
22     WRITE(6,6) CITY,YEAR,MONTH,DAY
23     4     FORMAT(50H0          STARTING DATE ON WEATHER TAPE          )
24     5     FORMAT('//'      CITY      YEAR      MONTH      DAY')
25     7     FORMAT('//'      DB      DP      WB      WS      PB      %
26     TC      NTOC')
27     6     FORMAT(5I10)
28     IF(IWRITE.NE.0) WRITE(6,7)
29     199   DO 90 J=1,24
30     1     IWS=OUTPUT(J,1)
31     IDR=OUTPUT(J,2)
32     KA=OUTPUT(J,3)
33     LA=OUTPUT(J,4)
34     IDP=OUTPUT(J,5)
35     IATM=OUTPUT(J,6)
36     ITCA=OUTPUT(J,7)
37     ITOC=2
38     ITK=OUTPUT(J,8)
39     IF(ITK.EQ.2) ITOC=1
40     IF(ITK.EQ.8.OR.ITK.EQ.9) ITOC=0
41     IPR=OUTPUT(J,9)
42     IPS=OUTPUT(J,10)
43     DB(J)=KA
44     WBT(J)=LA
45     DPT(J)=IDP
46     PBT(J)=IATM/100.
47     TC(J)=ITCA
48     NTOC(J)=ITOC
49     WST(J)=IWS
50     IF(IWRITE.EQ.0) GO TO 90

```



```
51          WRITE(6,91) DB(J),DPT(J),WBT(J),WST(J),PBT(J),TC(J),NTOC(J)
52          91      FORMAT(6F10.2,I10)
53          90      CONTINUE
54          100     WRITE(9) DB,DPT,WBT,WST,PBT,TC,NTOC,DAY,YEAR,MONTH,CITY
55          IF(IWRITE.EQ.0) WRITE(6,103) MONTH, DAY
56          103     FORMAT(2I10)
57          102     CONTINUE
58          CALL TPRCL
59          END FILE 9
60          STOP
61          END
```

```

1      SUBROUTINE WINTER(A,U,ITYPE,NEXP,CFMWT,DBIN,DBWI,UG,TGW,RHI,RHO)
2      DIMENSION A(30),U(30),ITYPE(30)
3      CALL DBRH(DBWI,RHO,W0)
4      CALL DBRH(DBIN,RHI,W1)
5      DT=DBIN-DBWT
6      DW=W1-W0
7      QWINTS=1.08*CFMWT*DT
8      QWINTL=4.5*CFMWT*DW*1060.
9      DO 30 I=1,NEXP
10     IF (ITYPE(I).EQ.6.OR.ITYPE(I).EQ.7) GO TO 30
11     IF (ITYPE(I).NE.5) GO TO 20
12     QWINTS=QWINTS+UG*A(I)*(DBIN-TGW)
13     GO TO 30
14     20 CONTINUE
15     QWINTS=QWINTS+U(I)*A(I)*DT
16     30 CONTINUE
17     TOTAL=QWINTS+QWINTL
18     WRITE(6,40) QWINTS,QWINTL,TOTAL
19     40 FORMAT(// ' HEATING LOAD IN BTU PER HOUR %/%'
20     '          SENSIBLE LOAD = 'F10.0/%'
21     '          LATENT   LOAD = 'F10.0/%'
22     '          -----!/%'
23     '          TOTAL   LOAD = 'F10.0//')
24     RETURN
25     END

```

```

1          FUNCTION WKDAY (YR,MO,DAY)
2          %      WKDAY=1 SUNDAY
3          %      WKDAY=2 MONDAY
4          %      WKDAY=3 TUESDAY
5          %      WKDAY=4 WEDNESDAY
6          %      WKDAY=5 THURSDAY
7          %      WKDAY=6 FRIDAY
8          %      WKDAY=7 SATURDAY
9          INTEGER YR,DAY,WKDAY,TDAY,FSTDAY
10         DIMENSION FSTDAY(12)/31,59,90,120,151,181,212,243,273,304,334,365/
11         N=YR/4
12         ND=N-485
13         IY=2
14         IF (ND.EQ.0) GO TO 40
15         IF (ND.LT.0) GO TO 10
16         IADD=2
17         GO TO 20
18         10    ND=-ND
19             IADD=-2
20         20    DO 30 J=1,ND
21             IY=IY-IADD
22             IF (IY.GT.7) IY=IY-7
23             IF (IY.EQ.0) IY=7
24             IF (IY.LT.0) IY=IY+7
25         30    CONTINUE
26         40    MD=YR-N*4
27             IF (MD.EQ.0) IWK=1Y
28             IF (MD.EQ.1) IWK=IY+2
29             IF (MD.EQ.2) IWK=IY+3
30             IF (MD.EQ.3) IWK=IY+4
31             IF (IWK.GT.7) IWK=IWK-7
32             IF (MO.NE.1) GO TO 50
33             TDAY=DAY-1
34             GO TO 80
35         50    DO 60 J=2,12
36             IF (MO.NE.J) GO TO 60
37             TDAY=FSTDAY(J-1)+DAY-1
38             GO TO 70
39         60    CONTINUE
40         70    IF (MD.EQ.0.AND.MO.GT.2) TDAY=TDAY+1
41         80    NTX=TDAY/7
42             NDX=TDAY-7*NTX+IWK
43             IF (NDX.GT.7) NDX=NDX-7
44             WKDAY=NDX
45             KV=YR/100
46             KTEST=YR-KV*100
47             IF (MO.GT.2.OR.KTEST.NE.0) GO TO 90
48             KV=KV-1
49         90    LV=KV/4
50             LTEST=KV-LV*4

```

WKDAY-PNC

PAGE 2

```
51           IF (LTEST.EQ.2) WKDAY=WKDAY+1
52           IF (LTEST.EQ.1) WKDAY=WKDAY+2
53           IF (LTEST.EQ.0) WKDAY=WKDAY+3
54           WKDAY=WKDAY-3*(LV-4)
55           100  IF (WKDAY.LE.0) WKDAY=WKDAY+7
56           IF (WKDAY.LE.0) GO TO 100
57           IF (WKDAY.GT.7) WKDAY=WKDAY-7
58           RETURN
59           END
```

WKDAY-PNC

PAGE 2

11. ASHRAE PSYCHROMETRIC CHART NO. 1

NORMAL TEMPERATURE
 BAROMETRIC PRESSURE 29.921 INCHES OF MERCURY
 COPYRIGHT 1963

AMERICAN SOCIETY OF HEATING, REFRIGERATING AND AIR-CONDITIONING ENGINEERS, INC.

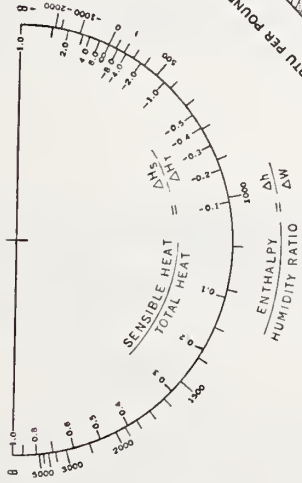

$$\frac{\text{ENTHALPY}}{\text{HUMIDITY RATIO}} = \frac{\Delta h}{\Delta W}$$

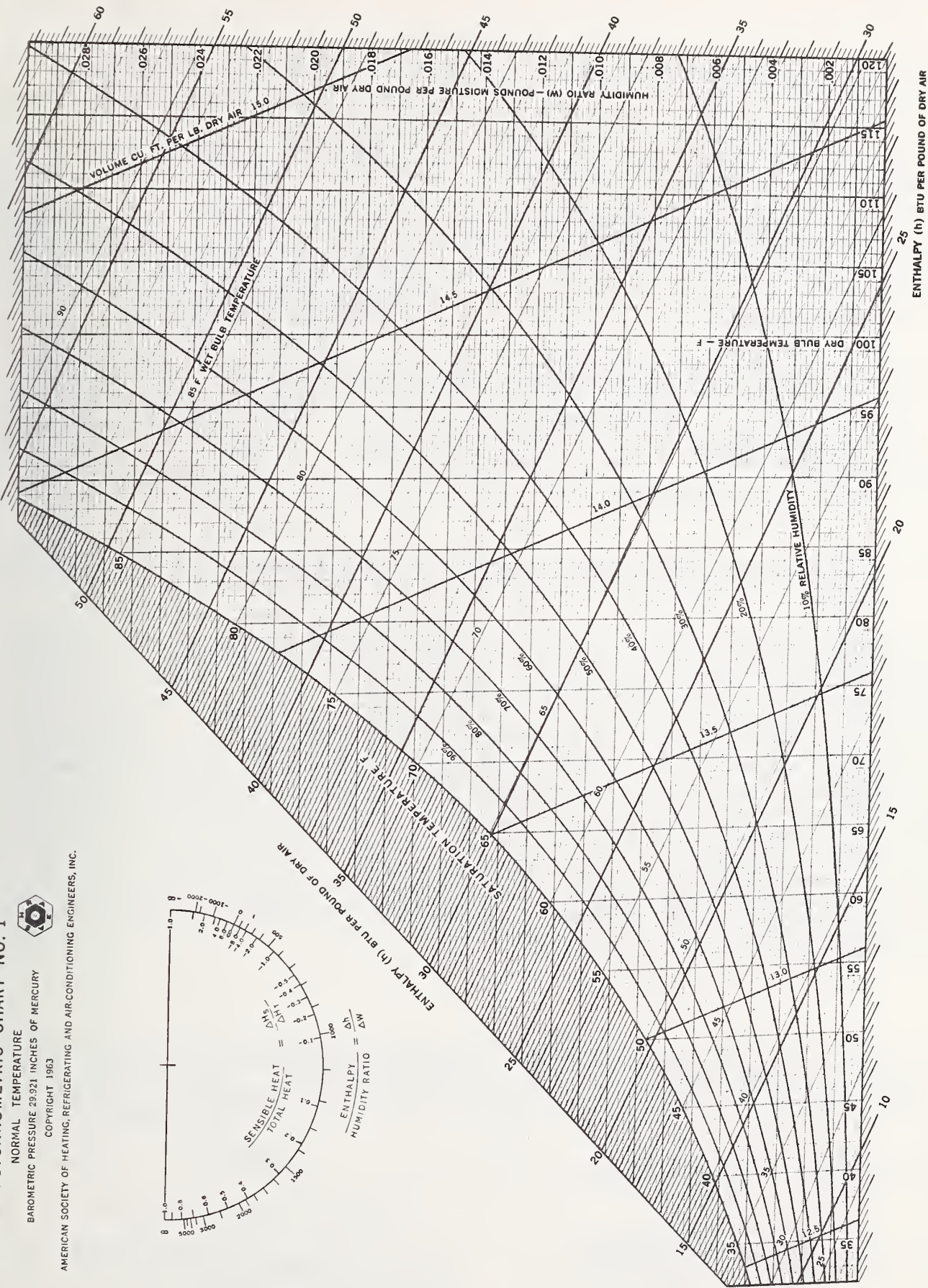

| | | | | |
|--|---|---|---|------------------|
| U.S. DEPT. OF COMM. BIBLIOGRAPHIC DATA SHEET | 1. PUBLICATION OR REPORT NO. NBSIR 74-574 | 2. Gov't Accession No. | 3. Recipient's Accession No. | |
| 4. TITLE AND SUBTITLE NBSLD, Computer Program for Heating and Cooling Loads in Buildings | | 5. Publication Date November 1, 1974 | 6. Performing Organization Code | |
| 7. AUTHOR(S) Tamami Kusuda | | 8. Performing Organ. Report No. | | |
| 9. PERFORMING ORGANIZATION NAME AND ADDRESS NATIONAL BUREAU OF STANDARDS DEPARTMENT OF COMMERCE WASHINGTON, D.C. 20234 | | 10. Project/Task/Work Unit No. | 11. Contract/Grant No. | |
| 12. Sponsoring Organization Name and Complete Address (Street, City, State, ZIP) National Bureau of Standards Housing and Urban Development Department of Commerce 451 7th Street, S.W. Washington, D. C. 20234 Washington, D. C. 20410 | | 13. Type of Report & Period Covered Final Report | 14. Sponsoring Agency Code | |
| 15. SUPPLEMENTARY NOTES | | | | |
| <p>16. ABSTRACT (A 200-word or less factual summary of most significant information. If document includes a significant bibliography or literature survey, mention it here.)</p> <p>A comprehensive computer program called NBSLD, the National Bureau of Standards Load Determination program, has been developed at NBS to reflect the time change of the many building parameters which are pertinent to accurate estimation of energy usage for heating and cooling. Current status of heating and cooling load techniques is reviewed. Of general interest are unique features of NBSLD which are not available in existing computer programs. A summary of various subroutines of NBSLD is given along with the detailed procedures for them. These subroutines constitute the recommended subroutine algorithms of the ASHRAE Task Group on Energy Requirements. Complete Fortran listing of NBSLD and data preparation forms are given for those who wish to use the program. The NBSLD computation is on the basis of the detailed solution of simultaneous heat balance equations at all the interior surfaces of a room or space. Transient heat conduction through exterior walls in the interior structures is handled by using conduction transfer functions. The use of heat balance equations, although time consuming in calculation, can avoid the vagueness and uncertainties inherent in the more popularly used weighting factor approach. In addition, it is more accurate for a specific building design.</p> | | | | |
| <p>17. KEY WORDS (six to twelve entries; alphabetical order; capitalize only the first letter of the first key word unless a proper name; separated by semicolons) ASHRAE Task Group on Energy Requirements; conduction transfer functions; heating and cooling load; National Bureau of Standards Heating and Cooling Load Computer Program</p> | | | | |
| <p>18. AVAILABILITY <input checked="" type="checkbox"/> Unlimited</p> <p><input type="checkbox"/> For Official Distribution. Do Not Release to NTIS</p> <p><input type="checkbox"/> Order From Sup. of Doc., U.S. Government Printing Office Washington, D.C. 20402, SD Cat. No. C13</p> <p><input checked="" type="checkbox"/> Order From National Technical Information Service (NTIS) Springfield, Virginia 22151</p> | <p>19. SECURITY CLASS (THIS REPORT)</p> <p>UNCLASSIFIED</p> | <p>21. NO. OF PAGES</p> <p>414</p> | <p>20. SECURITY CLASS (THIS PAGE)</p> <p>UNCLASSIFIED</p> | <p>22. Price</p> |

