

NBSIR 73-401

Performance of Coated Steel Reinforcement in Concrete. Part 1. Investigation of Bond in Pullout Specimens

Robert G. Mathey, James R. Clifton, Erik D. Anderson, Hugh F. Beeghly

Center for Building Technology
Institute for Applied Technology
National Bureau of Standards
Washington, D. C. 20234

May 1973

Prepared for
Federal Highway Administration
U. S. Department of Transportation
Washington, D. C. 20590

**PERFORMANCE OF COATED STEEL
REINFORCEMENT IN CONCRETE.
PART 1. INVESTIGATION OF BOND IN
PULLOUT SPECIMENS**

Robert G. Mathey. James R. Clifton. Erik D. Anderson. Hugh F. Beeghly

Center for Building Technology
Institute for Applied Technology
National Bureau of Standards
Washington, D. C. 20234

May 1973

Prepared for
Federal Highway Administration
U. S. Department of Transportation
Washington, D. C. 20590



U. S. DEPARTMENT OF COMMERCE, Frederick B. Dent, Secretary
NATIONAL BUREAU OF STANDARDS, Richard W. Roberts, Director

ABSTRACT

Bond strengths of coated deformed steel reinforcing bars were compared with uncoated bars by means of pullout specimens. The bond strengths were determined for 23 epoxy-coated (10 different epoxy coatings), 6 polyvinyl chloride-coated (3 different coating materials), and 5 uncoated deformed reinforcing bars. The tensile reinforcement in the pullout specimen consisted of No. 6 deformed bars, having either a barrel or diamond shaped deformation pattern, with a nominal yield strength of 60,000 psi. The length of embedment of the reinforcing bar in the concrete was 12 inches.

The load or bond stresses corresponding to a loaded-end slip of 0.01 inch or a free-end slip of 0.002 inch were considered as critical values in determining the bond strength, depending on which of these values of slip developed first.

For coating film thickness of approximately 10 mils or less, the epoxy-coated bars developed bond strengths essentially equal to the bond strengths for the uncoated bars. Experimental values of bond strengths for these coated bars were higher than minimum acceptable values given in building code and highway bridge requirements. Bond strengths of the polyvinyl chloride-coated bars and bars with thick epoxy coatings were unacceptable.

TABLE OF CONTENTS

	Page
Abstract.	i
1. Project Information	1
2. Project Background.	1
3. Pullout Test.	1
3.1 Materials and Specimens.	2
3.1.1 Reinforcement	2
3.1.2 Concrete.	2
3.1.3 Coatings on Reinforcing Bars.	3
3.1.4 Pullout Specimens	3
3.1.5 Fabrication and Curing of the Specimen.	4
3.2 Testing Procedure.	4
3.3 Results and Discussion	5
3.3.1 Load-Slip Relationships	6
3.3.2 Bond Stress	8
3.4 Summary and Conclusions.	9
4. References.	10

1. Project Information: Order No. 2-1-0614.

Title: Nonmetallic Coatings for Concrete Reinforcing Bars.

Date Project Initiated: September 17, 1971.

Research Agency: National Bureau of Standards.

2. Project Background. The premature deterioration of concrete bridge decks in 5-10 years has become a major problem during the past decade [1-7]. Often, this early deterioration has been attributed to accelerated corrosion of steel reinforcing bars (rebars) caused by chloride ions from deicing materials [8-9]. The use of the two more commonly applied deicing materials, sodium chloride and calcium chloride, has increased substantially during the past decade. Corrosion of reinforcing bars results in spalling and cracking of concrete, necessitating extensive and expensive repairs.

In the present project, the possibilities of protecting steel reinforcing bars with organic-type coatings are being investigated. Evaluations of the physical and chemical durabilities of 47 different coatings including epoxy and polyvinyl chloride materials were given in a previous report [10]. Assessments of their protective qualities were also included. It was concluded that among the organic materials, epoxy coatings had the most promise as a protective coating for reinforcing bars. The epoxies that had the best protective qualities and physiochemical durabilities were selected for testing in a comprehensive evaluation program. This program includes determining the structural characteristics, creep and bond strengths, of coated reinforcing bars embedded in concrete prisms. The bond strengths were measured in tests using pullout specimens (described in Section 3.1.4) and the results are presented in this report. Determinations of creep strength are currently being performed and the results will be given in a future report.

3. Pullout Tests. Little attention has been previously devoted to epoxy materials as protective coatings for rebars because of the supposition that the coated reinforcing bars will have unacceptable bond strengths [11]. No reports were found in the literature of any type of structural testing performed on epoxy coated rebars embedded in concrete.

In this section the methodology of pullout testing will be described along with a discussion of the experimental results. Altogether, 34

pullout specimens were tested, which were comprised of 5 specimens with uncoated reinforcing bars, 23 specimens with epoxy-coated bars, and 6 specimens with polyvinyl chloride-coated bars.

3.1 Materials and Specimens.

3.1.1 Reinforcement. The tensile reinforcement in the pullout tests consisted of No. 6 deformed bars (3/4 inch nominal diameter) having either a barrel (B) or diamond (D) shaped deformation pattern, as shown in figure 1. These bars were randomly selected and may not have been from the same heat of steel. A 4 foot length of each type of bar was tested to rupture in tension. The yield strengths determined by the "0.2 percent offset" [12] method were 67,600 psi for No. 6 rebars (D) and 62,500 psi for No. 6 rebars. These bars did not exhibit a well-defined yield point, however, their stress-strain relationships (figure 2) were linear up to a stress of about 64,000 psi for the (D) bars and approximately 62,000 psi for the (B) rebars. Tensile properties of the bars are listed in table 1. The yield and tensile strengths of the bars met the requirements of ASTM A615-72 [12] for Grade 60 bars. The properties of deformations were determined from three specimens from each type of bar and are given in table 2. The bar deformations also met the requirements of ASTM A615-72.

3.1.2 Concrete. The concrete was procured from a transit-mix concrete company. The mix proportions of portland cement (type III), sand, and coarse aggregate were approximately 1:1.7:2.5, by weight. The sand was a siliceous aggregate and the coarse aggregate was crushed stone. Maximum size of the coarse aggregate was 3/4 in. Water content of the concrete was about 5 1/2 gallons per sack of concrete and the slump ranged from 3 to 5 in. Three batches of concrete were used to cast 34 pullout specimens (12 specimens each from concrete batch Nos. 1 and 2, and 10 specimens from concrete batch No. 3).

Six standard 6 x 12 in. cylinders were cast from each batch of concrete along with the pullout specimens. The cylinders were stored and cured in the same manner as the pullout specimens; and their compressive strengths were measured at the same time as the specimens were tested. The compressive strength was determined in accordance with ASTM

C39-66 [13]. The average compressive strengths at 27 to 29 days were 6170 psi for concrete batch No. 1, 6620 psi for batch No. 2 and 5730 psi for batch No. 3. The range and coefficient of variation [14] of the strength of the concrete cylinders was 226 psi and 1.5, 136 psi and 0.8, 355 and 2.3 for concrete batches numbered 1, 2 and 3 respectively.

3.1.3 Coatings on Reinforcing Bars. Coating materials were applied to No. 6 reinforcing bars supplied by the National Bureau of Standards by the applicators or manufacturers handling the respective coatings. The applicator or manufacturer blasted the surface of the bars to a white finish [15], applied and cured the coatings as recommended by the manufacturer, and then returned the bars to NBS for testing.

The coating materials and the methods by which they were applied are described in table 3. The coating materials have been assigned code numbers for laboratory identification purposes with the numbering sequence indicating the chronological order in which the materials were received. The pullout specimens have been assigned the same code number as the coating on the respective embedded reinforcing bars.

3.1.4 Pullout Specimens. The pullout specimens were 10 x 10 x 12 in. concrete prisms with the 4 foot length of reinforcing bar concentric with the longitudinal axis of the specimens, so that the length of embedment of the bar in concrete was 12 inches. This length of embedment of the deformed bar was selected based on previous studies at NBS ([15] and unpublished data) and because the current ACI Standard 318-71, "Building Code Requirements for Reinforced Concrete" states that the development length should not be less than 12 inches [17]. The pullout specimen was designed so that the loaded-end slip reached a value of 0.01 inch corresponding to a steel stress of approximately one half its tensile strength when uncoated bars were embedded in the specimen. Load-end slip is defined as the relative movement between a point on the loaded portion of the reinforcing bar and the surface of concrete. Splitting of the concrete was minimized by reinforcing the specimen with a cylindrical cage of 2 x 2 - 12/12 welded wire fabric. The cages had a diameter of 8 in., extending the length of the specimen, and were concentric with the reinforcing bar. An instrumented pullout specimen is illustrated in figure 3.

3.1.5 Fabrication and Curing of the Specimen. The pullout specimens were cast with the reinforcing bar in a horizontal position in wooden forms, which were lined with stripping oil. The specimens were removed from the forms after 2 days, moist cured for 14 days with wet burlap and room cured at 73°F and 50 percent relative humidity until tested 27 to 29 days after being cast.

Two pullout specimens with uncoated (U) reinforcing bars were fabricated from each of concrete batch Nos. 1 and 2 and one such specimen was cast from batch No. 3. Two specimens were fabricated for each coating material from the same batch of concrete with the exception that only one pullout specimen was fabricated that contained coating No. 1-S.

3.2 Testing Procedure. Pullout specimens were tested in a 200,000 lb. capacity universal electromechanical testing machine. A pullout specimen positioned on the testing machine is shown in figure 4. The pullout specimen shown in figure 3 is seated on leather cushions, on two segments of a 2 in. base plate attached to a spherical bearing block. Free- and loaded-end slips of the reinforcing bar were measured with 1×10^{-4} in. micrometer dial gages. Free-end slip is defined as the relative movement between the unloaded end of the bar and the surface of concrete. At the loaded end of the specimen, two dial gages were attached to a steel bar fastened to the face of the concrete by bolts secured into inserts cast in the concrete. The gages bore on a steel yoke fastened to the reinforcing bar about 1 in. below the face of the concrete. The bar supporting the dial gages and the yoke was free to move in the recess in the base plate. The average of the two gage measurements gave the displacement of the point on the reinforcing bar where the yoke was attached, with reference to the face of the concrete. Slip at the free end was measured with a gage that bore on the exposed end of the reinforcing bar (any coating material on the exposed end of the reinforcing bar was removed prior to testing). The gage was mounted on a support attached to the top face of the concrete by bolts secured into insert cast in the concrete. Loads were applied in increments of 2,000 pounds to the reinforcing bars in the pullout tests until failure

occurred either by yielding of the steel or excessive slip between the bar and concrete was attained. At each load increment measured displacement data was recorded.

3.3 Results and Discussion. An important requirement for coated steel reinforcing bars is the necessity of having adequate bond strength when embedded in concrete. Adequate mean bond strengths of coated bars denotes values equal to or greater than those for the uncoated bars. Variability of the test results can allow acceptable bond strengths of coated rebars slightly less than the mean value of bond strengths of uncoated bars. In the present study, the relative bond strengths of coated and uncoated bars were determined by testing pullout specimens. Bond failure in a reinforced concrete flexural member is defined as excessive slip, or movement (greater than 0.002 in.), of the free end of a bar stressed in tension caused by only a slight increase in the applied load [16]. This slight increase in load results in a significant change in the slope of the load-slip curve.

In the bond study of Mathey and Watstein [16] critical bond stresses were determined from bond stress-slip relationships. The critical bond stress was taken as the lower value of bond stress corresponding to a loaded end slip of 0.01 inch or a free end slip of 0.002 in. It was observed in general that significant changes in slope of the bond stress-slip relationship occurred at these values of the slip for various lengths of embedments in beams containing No. 4 or No. 8 bars.

Comparison of bond strength data for beam and pullout specimens in the study of Mathey and Watstein [16] indicated that considerably lower critical bond strengths were developed in pullout specimens compared to beam specimens having the same length of embedment. The length of embedment to bar diameter ratios in these specimens containing No. 4 and 8 bars having comparable concrete strengths were 14, 21, 28 and 34. The critical bond strengths for the pullout specimens ranged from 43 to 96 percent of the critical bond strengths for the beam specimens. The average value of critical bond strength for the pullout specimen was 75 percent of the values determined from beam specimens. In that study the values of steel stresses corresponding to the critical bond strengths were considerably lower than the yield strengths of the steel bars.

3.3.1 Load-Slip Relationships. The relationships between applied load and the free-end and loaded-end slip are plotted in figure 5 for the 34 pullout specimens tested. Roman numerals denote the concrete batch number while the Arabic numbers next to the plots identify the coating materials (table 3). The loaded-end slip was larger than the free-end slip for all specimens tested primarily because slipping initiates at the loaded-end and extends toward the free-end as the load is increased. Test results indicate that the critical bond stress is as important as the maximum load carried by the reinforcing bar in evaluating the performance of coated reinforcing bars in the pullout tests.

In the comparison of the bond strengths developed in the pullout tests of uncoated and coated reinforcing bars the variation in the concrete strength, f'_c , was considered. Values of $\sqrt{f'_c/f'_c}$ were 1.00, 0.97 and 1.04 for the three batches of concrete designated I, II, and III respectively. The average strength of concrete, \bar{f}'_c , for all three batches was 6170 psi. The values of all calculated bond stresses were adjusted for the differences in concrete strength by multiplying them by the ratio of $\sqrt{\bar{f}'_c/f'_c}$.

Yielding of the reinforcing bar was attributed as failure in most tests, with the exception being pullout specimens containing bars coated with materials Nos. 22, 23, 24 and 30. Although yielding of the reinforcing bar occurred in most tests, the critical bond strength corresponded to steel stresses well below the yield strength of the steel. It will be recalled that the critical bond strength or bond stress is defined as the lower value of bond strength or bond stress corresponding to a loaded-end slip of 0.01 in. or a free-end slip of 0.002 in. The critical bond strength corresponded to applied loads ranging from 17,000 to 21,600 lb. for uncoated bars and for coated bars except those coated with materials Nos. 22, 23, 24 and 30 (table 4). Material No. 22 is a powder epoxy applied by the fluidized bed method producing a cured film about 24 mils thick. Coatings Nos. 23, 24 and 30 are polyvinyl chloride materials. The other coatings are epoxy coatings ranging from 1 to 11 mils thick. The applied load corresponding to the critical bond strength in the 19 pullout specimens with bars having epoxy coatings

1 to 11 mils thick ranged from 17,000 to 21,500 lb. with an average value of 19,100 lb. The applied load corresponding to the critical bond strength in the 5 pullout specimens with uncoated bars ranged from 18,000 to 21,600 lb. with an average value of 20,300 lb. Variability of the test results can allow acceptable bond strengths of coated rebars to be slightly less than the mean value of bond strengths of uncoated bars. Adequate mean bond strengths of coated bars denotes values comparable to those for uncoated bars. The average value of applied load corresponding to the critical bond strength in the 19 pullout specimens with the bars having epoxy coatings 1 to 11 mils thick was 6 percent less than for the pullout specimens containing the uncoated bars. Therefore, these particular coated bars are concluded to have acceptable bond strengths.

The average applied loads corresponding to the critical bond strength in pullout specimens containing rebars with coatings Nos. 22, 23, 24 and 25 were 9,000, 1,100, 60 and 5,700 lb. respectively. Critical bond strengths developed in pullout specimens containing rebars having these coatings were considerably less than the values of critical bond strengths determined from pullout specimens containing the uncoated bars.

A comparison of the bond strengths based on maximum load can also be made for coated and uncoated bars. Values of maximum applied loads are also presented in table 4. It is noted from this table that the maximum load for all pullout specimens except those containing bars having coatings Nos. 22, 23, 24, and 30 corresponded to yielding of the reinforcement. When the steel stresses considerably exceeded the yield strength of the bar, loading was halted. It will be recalled that the steel stress corresponding to the critical bond strength was considerably less than the yield strength of the bar for all the pullout specimens. An evaluation of the pullout test results (table 4) indicates that epoxy-coated reinforcing bars have bond strengths essentially equal to uncoated bars when the film thicknesses are approximately 10 mils or less. Both liquid and powder epoxies performed equally well, and the application method did not significantly effect the bond strength of coated bars. The polyvinyl chloride coated bars had bond strengths considerably less than that for uncoated bars and bars with these coatings are not recommended for structural use. The lower bond strengths for

polyvinyl coated bars are attributed in part to the thermoplastic nature of the polyvinyl chloride. The thicknesses of the polyvinyl chloride film were greater than most of the epoxy films but thicker films are normal for thermoplastics [18].

3.3.2 Bond Stress. It was noted in Section 3.3 that in a previous study the average bond strength of pullout specimens was 75 percent of the average value for beam specimens. Although pullout test results are not recognized as being comparable to beam test results, the authors believe that relative bond characteristics of reinforcing bars can be determined from pullout tests. The lower value of bond stress corresponding to a loaded-end slip of 0.01 in. or a free-end slip of 0.002 in. is defined as the critical bond stress. The bond stresses corresponding to these values of slip are presented in table 4. Bond stresses were computed from the formula

$$u = \frac{f_s A_s}{\sum_o L} \quad (1)$$

where f_s is the stress in the reinforcing bar, A_s is the nominal cross sectional area of the bar, \sum_o is the nominal perimeter of the bar and L is the length of embedment, in inches, of the reinforcing bar in the pullout specimen. Values of A_s and \sum_o for each of the two types of rebars are given in table 1. The value of f_s is given by

$$f_s = \frac{P}{A_s} \quad (2)$$

where P is the load or tensile force applied to the reinforcing bar in pounds. Therefore, equation (1) can be reduced to

$$u = \frac{P}{\sum_o L} \quad (3)$$

which was used to calculate u . Values of bond stress developed in the pullout specimens were compared with allowable values given in codes and specifications. The American Concrete Institute Building Code, 318-63 [19], allowed a working bond stress design for deformed bars (other than top bars) conforming to ASTM A 305 calculated from

$$\frac{4.8 \sqrt{f'_c}}{D}, \text{ but not more than 500 psi}$$

where D is the nominal diameter of the bar in inches. Using the average value of f'_c as 6170 psi the bond stress, u , is 490 or about 500 psi.

The Standard Specification for Highway Bridges Adopted by the American Association of State Highway Officials [20] states that slabs (decks) designed for bending moment in accordance with the given provisions shall be considered satisfactory in bond and shear. In another section of this Standard Specification on concrete design the allowable bond stress for tension bars conforming to AASHTO M31 [20] and ASTM A615 [12] is

$$4.8 \sqrt{f'_c} , \quad 500 \text{ psi maximum}$$

and is the same as that given by the ACI 318-63 Code.

The critical bond stresses and bond stresses corresponding to one half the maximum applied load, $\frac{U_m}{2}$ given in table 4 for all pullout specimens except those having bars coated with materials 22, 23, 24 and 30 were greater than 600 psi.

3.4 Summary and Conclusions. Bond strengths were determined in 34 pullout specimens with 23 epoxy coated (10 different epoxy coatings), 6 polyvinyl chloride coated (3 different materials), and 5 uncoated No. 6 deformed reinforcing bars. In general, the comparable pullout tests indicated that bars with epoxy coatings approximately 10 mils or less in thickness developed essentially the same bond strengths as the uncoated bars. When the film thickness of the epoxy coating was 25 mils or when polyvinyl coatings were used the bond strength was considerably less for these coated bars than for the uncoated bars. It is recommended that thick epoxy coatings (greater than approximately 10 mils) and polyvinyl chloride coatings not be used as protective coatings for reinforcement in concrete flexural members.

As stated in Section 3.3, the bond strengths from pullout tests do not necessarily agree with the bond strengths of comparable flexural members. Although the information on relative bond strengths of coated and uncoated reinforcing bars determined by means of pullout tests are believed valid by the authors, it is recommended that tests of flexural members (slabs) be carried out to confirm these results. Furthermore, the authors recommend that studies on the creep properties of coated

bars be conducted to determine if deformation of the coatings will cause excessive slip of the reinforcing bar in the concrete over a long period of time. Determinations of creep strengths are currently being performed by means of pullout type specimens and the results will be given in a future report.

4. References

1. "Durability of Concrete Bridge Decks: A Cooperative Study, State Highway Commission of Kansas, Bureau of Public Roads and Portland Cement Association". Report 1 (1965).
2. "Durability of Concrete Bridge Decks: A Cooperative Study, Michigan State Highway Department, U. S. Department of Commerce, Bureau of Public Roads and Portland Cement Association". Report 2 (1965).
3. "Durability of Concrete Bridge Decks: A Cooperative Study, U. S. Department of Transportation, Bureau of Public Roads and Portland Cement Association". Report 3 (1967).
4. "Durability of Concrete Bridge Decks: A Cooperative Study, Missouri State Highway Commission, U. S. Department of Transportation, Bureau of Public Roads and Portland Cement Association". Report 4 (1968).
5. "Durability of Concrete Bridge Decks: A Cooperative Study; California, Illinois, Michigan, Minnesota, New Jersey, Ohio, Texas, and Virginia Highway Departments, U. S. Department of Transportation, Bureau of Public Roads and Portland Cement Association". Report 5 (1969).
6. "Durability of Concrete Bridge Decks: A Cooperative Study; California, Illinois, Kansas, Michigan, Minnesota, Missouri, New Jersey, Ohio, Texas, and Virginia Highway Departments, U. S. Department of Transportation, Bureau of Public Roads and Portland Cement Association". Final Report (1970).
7. T. D. Larson, P. D. Cady, and J. C. Theisen, "Durability of Bridge Deck Concrete", Report No. 7, College of Engineering, The Pennsylvania State University, April (1969).
8. R. F. Stratfull, "The Corrosion of Steel in a Reinforced Concrete Bridge", Corrosion, 13, 173t (1957).
9. J. D. Mozer, A. C. Bianachini and C. E. Kelser, "Corrosion of Reinforcing Bars in Concrete", J. Am. Concrete Inst. Proceedings, 62, 909 (1965).
10. J. R. Clifton, H. F. Beeghly and R. G. Mathey, "Interim Report No. 4 Screening Test for Evaluating Materials", National Bureau of Standards Report 10968.
11. R. C. Robinson, "Design of Reinforced Concrete Structures for Corrosive Environments", Materials Performance, 11, 15 (1972).
12. Standard Specification for Deformed and Plain Billet-Steel Bars for Concrete Reinforcement, ASTM Designation A615-72.
13. Standard Method of Test for Compressive Strength of Molded Concrete Cylinders, ASTM Designation C39-66.

14. ACI Standard, Recommended Practice for Evaluation of Compression Test Results of Field Concrete (ACI 214-65), American Concrete Institute, 1965.
15. Steel Structures Painting Council Surface Preparation Specification SSPC-SP5-63, amended 1971.
16. R. G. Mathey and D. Watstein, "Investigation of Bond in Beam and Pullout Specimens with High-Yield-Strength Deformed Bars," ACI Journal, 32, 1071 (1961).
17. ACI Standard Building Code Requirement for Reinforced Concrete, (ACI 318-71), February 1971.
18. N. E. Hamner, "Coatings for Corrosion Protection," Chapter 14, in NACE Basic Corrosion Course, A. des. Brasunas and N. E. Hamner, ed., National Association of Corrosion Engineers, Houston, Texas, 1970.
19. ACI Standard Building Code Requirements for Reinforced Concrete (ACI 318-63), June 1963.
20. Standard Specifications for Highway Bridges, Adopted by The American Association of State Highway Officials, Eleventh Edition 1973.

Captions for Figures

- Figure 1. View of No. 6D (upper bar) and No. 6B (lower bar) reinforcing bars. D indicates diamond shaped deformation pattern and B indicates barrel pattern.
- Figure 2. Typical stress-strain characteristics of reinforcing bars.
- Figure 3. Schematic of pullout specimen.
- Figure 4. Pullout specimen on electromechanical testing machine being prepared for testing.
- Figure 5. Applied load to reinforcing bar in pullout specimens versus free-end and loaded-end slip. Roman numbers indicate concrete batch number, while Arabic numbers identify the coating materials (table 3).

TABLE 1. PROPERTIES OF REINFORCING BARS

Bar Size and Type	Area, A_s (in ²)	Perimeter, Σ_0 (in)	Yield ^{1/} Strength f_y (psi)	Proportional Limit (psi)	Tensile Strength (psi)	Modulus of Elasticity, E_s (10 ⁶ psi)	Elongation in 10 in (percent)
No. 6D ^{2/}	0.441	2.35	67,600	63,900	95,700	30.7	11.2
No. 6H ^{3/}	0.434	2.34	62,500	61,800	95,200	28.4	8.2

^{1/} Yield strength was determined by the "0.2 percent offset" method.

^{2/} D denotes diamond deformation pattern.

^{3/} H denotes horizontal deformation pattern.

TABLE 2. PROPERTIES OF DEFORMATIONS 1/

Bar Size and Type	Width of gap (in.)	Average Spacing (in)	Average Height (in)	Average Projected Length (in)	Bearing Area (in ² /in)
No. <u>2/</u> 6D	0.064	0.300	0.040	2.22	0.296
No. <u>3/</u> 6B	0.047	0.402	0.038	2.25	0.212

1/ Methods of measuring properties of deformation and definition of terminology are given in reference 12.

2/ D denotes diamond deformation pattern.

3/ B denotes barrel deformation pattern.

TABLE 3 . COATED REINFORCING BARS^{1/}

Coating Code No.	Type of Coating Materials	Film Thickness (mil)	Application Method
U	No Coating		
1	Epoxy, liquid	4 - 5	Brush
1-S	Material No. 1 mixed with sand	4 - 5	Brush
3	Epoxy, liquid	2 - 5	Brush
18	Coal tar epoxy, liquid	4	Brush
19	Epoxy, liquid	1	Dipping
22	Epoxy, powder	25	Fluidized Bed
23	Polyvinylchloride, powder	23	Fluidized Bed
24	Polyvinylchloride-plastisol, powder	35	Fluidized Bed
25	Epoxy, powder	6 - 11	Electrostatic Spray Gun
29	Epoxy, powder	1 - 2	Electrostatic Spray Gun
30	Polyvinylchloride, powder	15 - 18	Fluidized Bed
31	Epoxy, powder ^{2/}	8 - 9	Electrostatic Spray Gun
38	Epoxy, powder	2 - 4	Electrostatic Spray Gun
38-Ph	Rebar surface phosphatized, then material No. 38 applied	2 - 4	Electrostatic Spray Gun
39	Epoxy, powder	2 - 4	Electrostatic Spray Gun
41	Epoxy, powder	3 - 7	Electrostatic Spray Gun

^{1/} No. 6 steel reinforcing bars coated by applicators or coating producers. Mill scale removed by sandblasting.

^{2/} Same material as No. 22, but applied by different method, by different applicator.

TABLE 3. COATED REINFORCING BARS^{1/}

Coating Code No.	Type of Coating Materials	Film Thickness (mil)	Application Method
U	No Coating		
1	Epoxy, liquid	4-5	Brush
1-S	Material No. 1 mixed with sand	4-5	Brush
3	Epoxy, liquid	2-5	Brush
18	Coal tar epoxy, liquid	4	Brush
19	Epoxy, liquid	1	Dipping
22	Epoxy, powder	25	Fluidized Bed
23	Polyvinyl chloride, powder	23	Fluidized Bed
24	Polyvinyl chloride-plastisol, powder	35	Fluidized Bed
25	Epoxy, powder	6-11	Electrostatic Spray Gun
29	Epoxy, powder	1-2	Electrostatic Spray Gun
30	Polyvinyl chloride, powder	15-18	Fluidized Bed
31	Epoxy, powder ^{2/}	8-9	Electrostatic Spray Gun
38	Epoxy, powder	2-4	Electrostatic Spray Gun
38-Ph	Rebar surface phosphatized, then material No. 38 applied	2-4	Electrostatic Spray Gun
39	Epoxy, powder	2-4	Electrostatic Spray Gun
41	Epoxy, powder	3-7	Electrostatic Spray Gun

^{1/} No. 6 steel reinforcing bars were coated by applicators or coating producers. Mill scale was removed by sandblasting.

^{2/} Same material as No. 22, but was applied by a different method and by a different applicator.

TABLE 4. PULLOUT DATA

Pullout No.	Compressive Strength of Concrete f'_c (psi)	Maximum Applied Load P_{max} (lb)	Maximum Computed Steel Stress $f_{s,max}$ (psi)	Maximum Computed Bond Stress u_m (psi)	Load Corresponding to Critical Bond Strength P_{cr} (lb)	Steel Stress Corresponding to Critical Bond Strength $f_{s,cr}$ (psi)	Maximum Slip Observed at Free End (in)	Maximum Slip Corresponding to Free-End Slip of 0.002 in. in. u_1 (psi) u_2 (psi)	$\frac{u_m}{2}$ (psi)	Mode of Failure	
U-B	6170	40,000	92,100	1423	20,100	46,800	.006	410	214	605	Bond failure. Small longitudinal crack extending entire length of specimen on two opposite faces.
U-B	6170	38,000	87,600	1257	18,000	41,500	.007				
U-B	5730	38,000	87,600	1458	20,000	46,100	.006	670	1056	675	Yielding of reinforcement. Small longitudinal crack extending one third length of specimen on two opposite faces.
U-D	6620	36,200	86,200	1256	21,600	48,900	.006	646	956	674	Yielding of reinforcement. Small longitudinal crack extending one third length of specimen on two opposite faces.
U-D	6170	40,600	92,100	1328	21,400	48,500	.002				
I-B	5730	38,000	87,600	1455	21,200	48,800	.003	702	1129	766	Yielding of reinforcement; no cracks.
I-D	5730	34,000	77,100	1290	18,000	40,800	.003	762	1032	726	Yielding of reinforcement. Small longitudinal crack extending one third length of specimen on two opposite faces.
I-B-S	5730	38,000	87,600	1455	17,100	39,400	.01				

TABLE 4. PULLOUT DATA (continued)

Pullout No.	Compressive Strength of Concrete f'_c (psi)	Maximum Applied Load P_{max} (lb)	Maximum (lb) Steel Stress $f_{s,max}$ (psi)	Maximum (computed) Bond Stress u_m (psi)	Computed Load Corresponding to Critical Bond Strength P_{cr} (lb)	Steel Stress Corresponding to Critical Bond Strength $f_{s,cr}$ (psi)	Maximum Slip Observed at Free End (in)	Maximum Slip Bond Stress Corresponding to Free-End Slip of 0.002 in. u_1 (psi)	Free-End Slip of 0.002 in. u_2 (psi)	Mode of Failure
3-B	5730	38,000	87,600	1455	20,000	46,100	.006	723	978	712 Yielding of reinforcement; no cracks.
3-D	5730	34,000	77,100	1293	21,000	47,600	.002	641	889	629 Yielding of reinforcement. Small longitudinal crack extending one third length of one face. Small transverse crack at loaded end.
18-B	6170	38,000	87,600	1350	21,500	49,600	.002			
18-D	6170	38,000	86,200	1347	18,800	42,600	.003	712	1157	729 Yielding of reinforcement. Small longitudinal crack extending one half length of specimen on one face.
19-B	5730	38,000	87,600	1455	19,000	43,700	.004	764	1037	628 Yielding of reinforcement; no cracks.
22-B-1	6620	30,000	69,200	994	11,600	26,700	.01	755	1/	664 Yielding of reinforcement; no cracks.
22-B-2	6620	15,800	36,300	3/	6,500	15,000	3/	751	1185	727 Yielding of reinforcement; no cracks.
23-B	6620	27,000	62,400	894	700	1,600	4/	638	1060	645 Yielding of reinforcement. Small longitudinal crack extending one half length of specimen on two opposite faces.
								609	925	727 Yielding of reinforcement; no cracks.

TABLE 4. PULLOUT DATA (continued)

Pullout No.	Compressive Strength of Concrete f'_c (psi)	Maximum Applied Load P_{max} (lb)	Maximum Steel Stress f_s (psi)	Maximum Computed Bond Stress u_m (psi)	Load Corresponding to Critical Bond Strength P_{cr} (lb)	Steel Stress Corresponding to Critical Bond Strength $f_{s,cr}$ (psi)	Maximum Slip Observed at Free End (in)	Bond Stress Corresponding to Slip of 0.01 in. u_1 (psi)	Free-End Slip of 0.002 in. u_2 (psi)	Mode of Failure	
23-0	6620	24,000	54,500	791	1,400	3,200	.03	712	1210	727	Yielding of reinforcement; no cracks.
24-B	6620	8,000	18,500	266	100	300	.05	745	1199	646	Yielding of reinforcement. Small longitudinal crack extending one sixth of length of specimen on one face.
24-D	6620	10,000	22,700	331	30	64	.06	766	1352	675	Yielding of reinforcement; no cracks.
25-0-1	6620	38,600	87,600	1276	18,500	41,900	.003	677	1089	727	Yielding of reinforcement. Small longitudinal crack extending one sixth length of specimen on two faces.
25-D-2	6620	38,000	86,200	1256	17,800	40,400	.005	759	1277	726	Yielding of reinforcement; no cracks.
29-B-1	6170	38,000	87,600	1347	17,000	39,200	.004	455	413	497	Bond failure. Small transverse crack extending one half length of loaded end.
29-B-2	6170	35,400	81,600	1276	18,200	41,900	.004	107	25	447	Bond failure. Specimen badly cracked.

TABLE 4. PULLOUT DATA (continued)

Pullout No.	Compressive Strength of Concrete f'_c (psi)	Maximum Applied Load P_{max} (lb)	Maximum Computed Steel Stress f_s_{max} (psi)	Maximum Computed Bond Stress u_m (psi)	Load Corresponding to Critical Bond Strength P_{cr} (lb)	Steel Stress Corresponding to Critical Bond Strength $f_{s,cr}$ (psi)	Maximum Slip (observed at Free End) (in)	Bond Stress Corresponding to Slip of 0.01 in. u_1 (psi)	Bond Stress Corresponding to Free-End Slip of 0.002 in. u_2 (psi)	Mode of Failure	
30-B	6170	34,000	78,300	1210	6,000	13,800	.03	167	50	395	Bond failure. Specimen badly cracked.
30-D	6170	32,000	72,600	1139	5,400	12,300	.02	18	5	133	Bond failure. Excessive free-end slip.
31-D	6170	38,000	86,200	1150	19,500	44,200	.012	656	1050	638	Bond failure. Excessive free-end slip.
31-B	6170	38,000	87,600	1347	18,700	43,100	.006	631	922	628	Yielding of reinforcement. Small longitudinal crack extending one half of length of specimen on two opposite faces.
38-B	5730	40,000	92,100	1533	19,700	45,400	.008	605	979	673	Yielding of reinforcement. Small longitudinal crack extending one third of length of specimen on two opposite faces.
38-D-Ph	5730	38,000	86,200	1451	21,500	48,700	.003	648	1033	638	Yielding of reinforcement. Small longitudinal crack extending one third of length of specimen on two opposite faces.

TABLE 4. PULLOUT DATA (cont inued)

Pullout No.	Compressive Strength of Concrete f'_c (psi)	Maximum Applied Load P_{max} (lb)	Maximum Computed Steel Stress $f_{s,max}$ (psi)	Maximum Computed Bond Stress u_m (psi)	Load Corresponding to Critical Bond Strength P_{cr} (lb)	Steel Stress Corresponding to Critical Bond Strength $f_{s,cr}$ (psi)	Maximum Slip Observed at Free End (in)	Bond Stress at Loaded-End Slip of 0.01 in. u_1 (psi)	Bond Stress Corresponding to Free-End Slip of 0.002 in. u_2 (psi)	Maximum Slip Corresponding to Free-End Slip of 0.002 in. $\frac{u_m}{2}$ (psi)	Mode of Failure
39-D	6620	38,600	87,600	1276	20,000	45,400	.004	709	1177	638	Yielding of reinforcement. Small longitudinal crack extending one sixth of specimen on two opposite faces.
39-B	6620	37,400	86,200	1256	17,500	40,300	.004	623	1122	628	Yielding of reinforcement. Small longitudinal crack extending one sixth of specimen on two opposite faces.
41-D	6170	38,600	87,600	1350	18,500	42,200	.004	656	1046	675	Yielding of reinforcement. Small longitudinal crack extending entire length of two opposite faces.
41-B	6170	37,400	86,200	1347	17,000	39,200	.004	605	1068	673	Yielding of reinforcement; no cracks.

1/ Unreliable data due to sticking gage.

2/ Failure took place before free-end slip of 0.005 in. was reached.

3/ Test stopped at f_s of 36,300 with free-end slip of 0.007.

4/ Not recorded, greater than .02 inch.

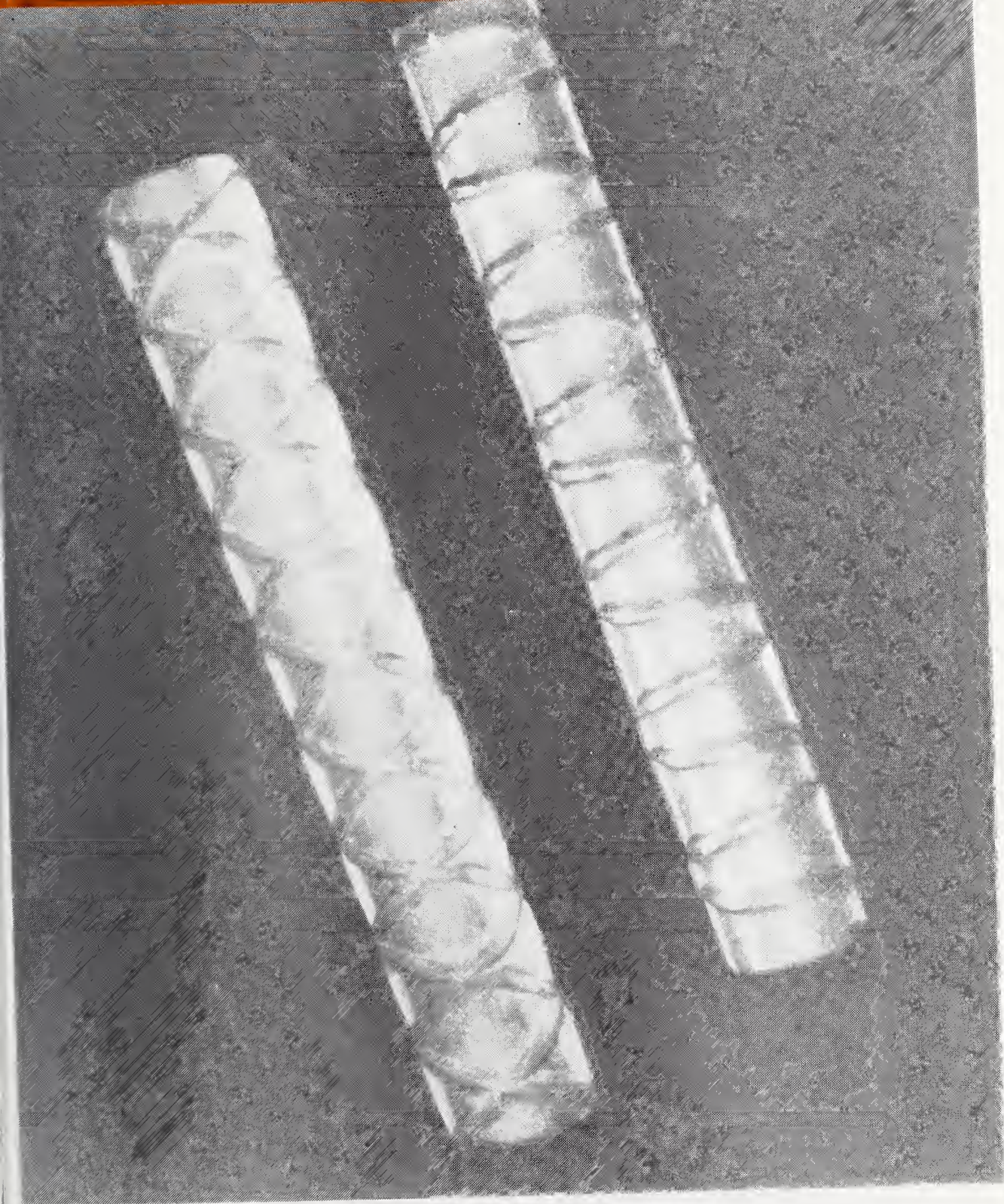

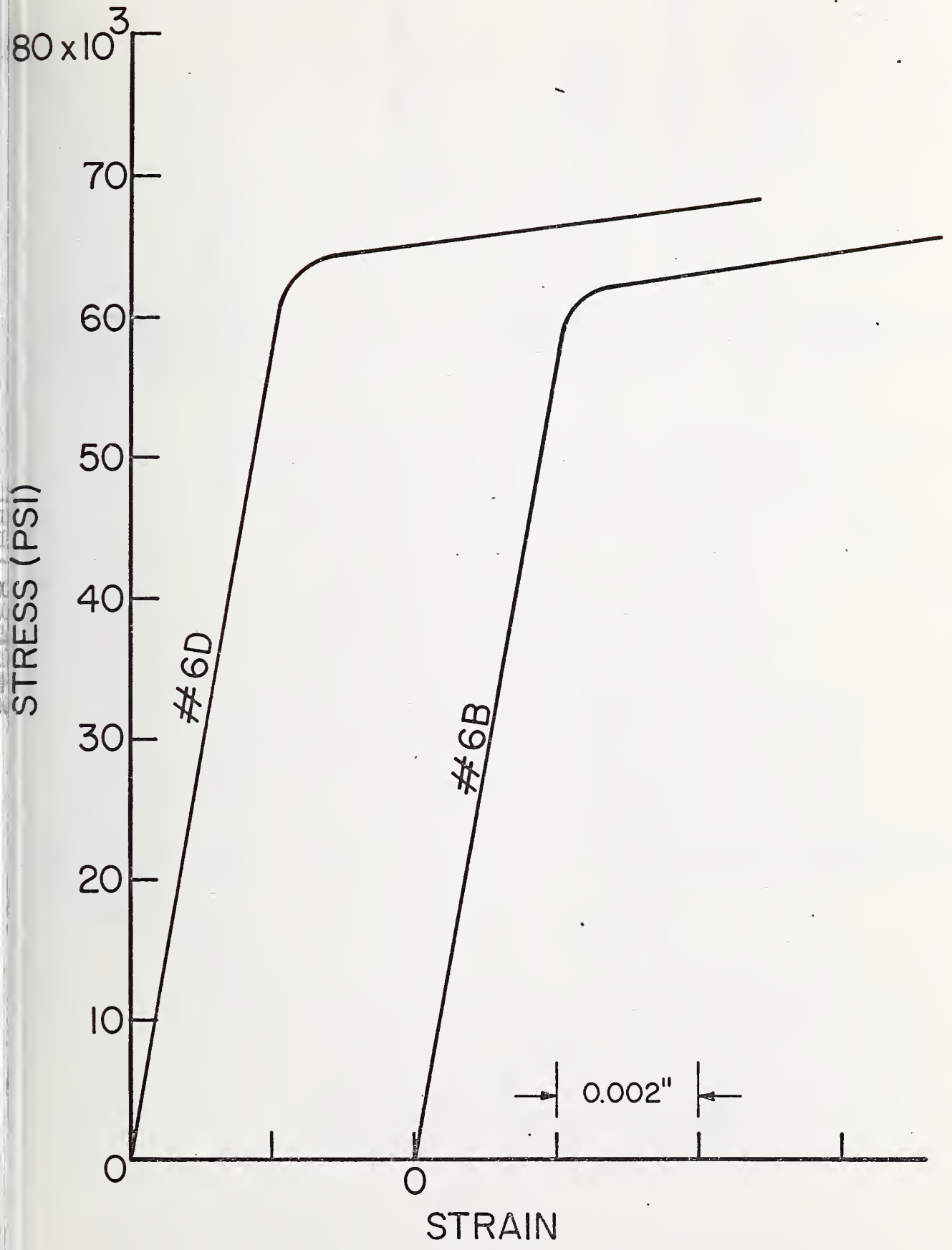

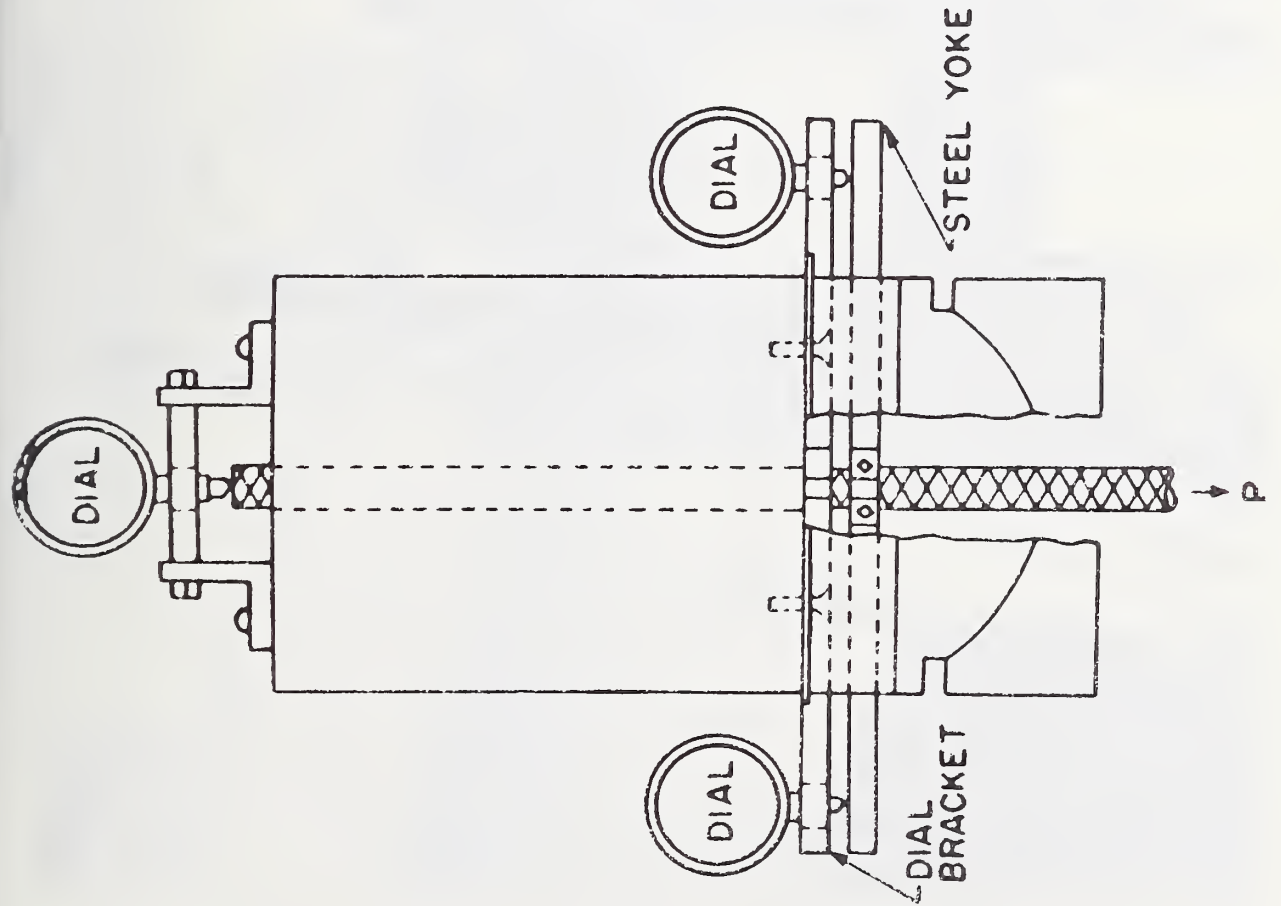
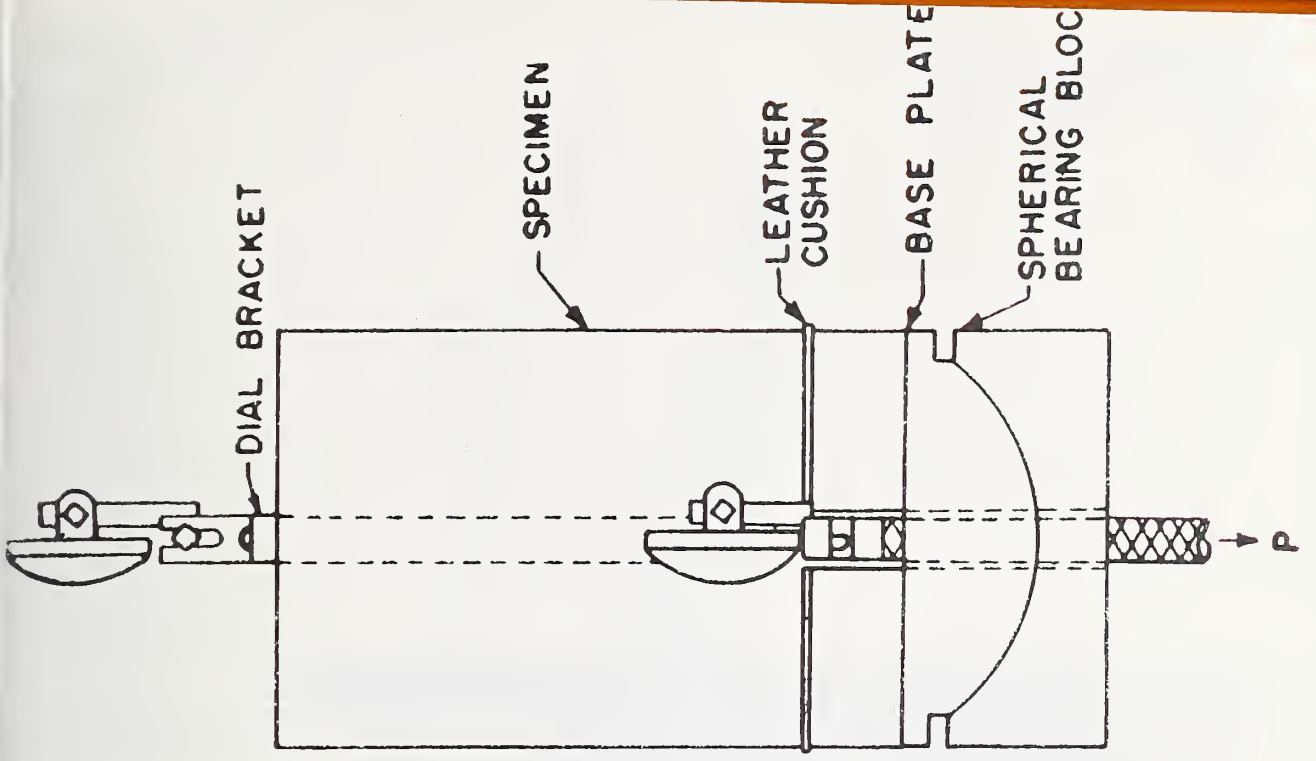



I

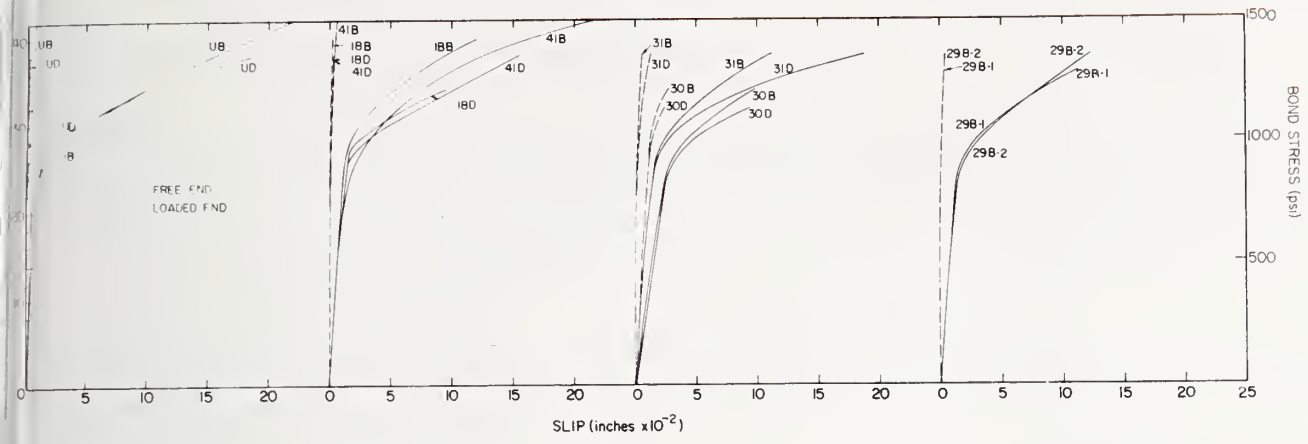

II

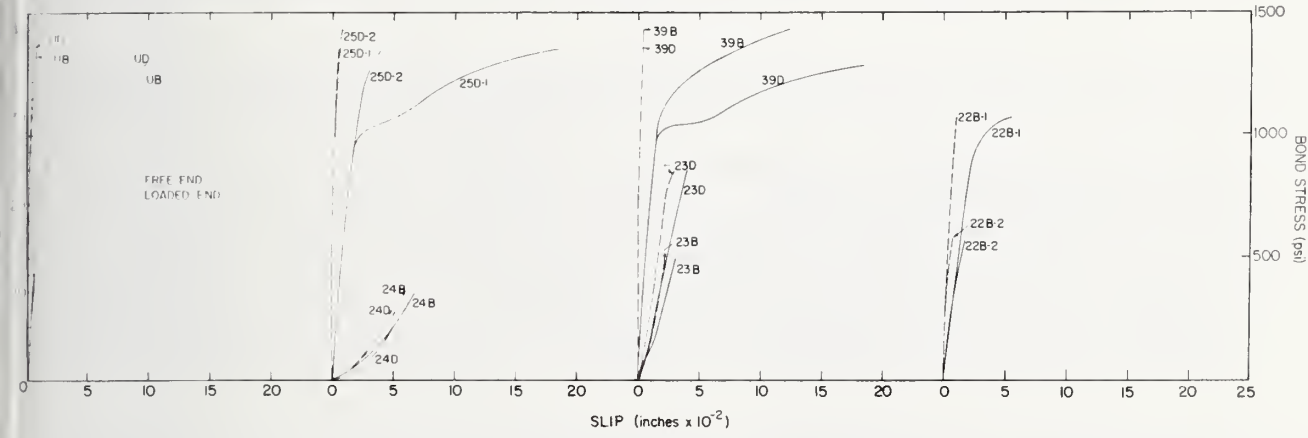

III

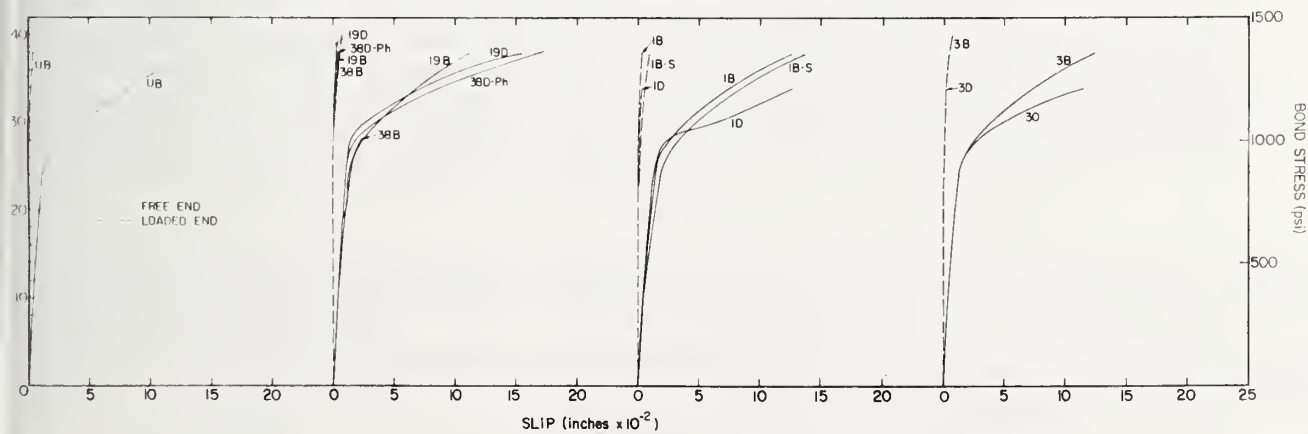

U.S. DEPT. OF COMM. BIBLIOGRAPHIC DATA SHEET	1. PUBLICATION OR REPORT NO. NBSIR 73-401	2. Gov't Accession No.	3. Recipient's Accession No.
4. TITLE AND SUBTITLE Performance of Coated Steel Reinforcement in Concrete. Part 1. Investigation of Bond in Pullout Specimens		5. Publication Date May 1973	6. Performing Organization Code
7. AUTHOR(S) James R. Clifton, Hugh F. Beeghly, Robert G. Mathey		8. Performing Organization NBSIR 73-401	
9. PERFORMING ORGANIZATION NAME AND ADDRESS NATIONAL BUREAU OF STANDARDS DEPARTMENT OF COMMERCE WASHINGTON, D.C. 20234		10. Project/Task/Work Unit No.	11. Contract/Grant No.
12. Sponsoring Organization Name and Address Federal Highway Administration Department of Transportation Washington, D. C. 20590		13. Type of Report & Period Covered Final	
15. SUPPLEMENTARY NOTES		14. Sponsoring Agency Code	
<p>16. ABSTRACT (A 200-word or less factual summary of most significant information. If document includes a significant bibliography or literature survey, mention it here.)</p> <p>Bond strengths of coated deformed steel reinforcing bars were compared with uncoated bars by means of pullout specimens. The bond strengths were determined for 23 epoxy-coated (10 different epoxy coatings), 6 polyvinyl chloride-coated (3 different coating materials), and 5 uncoated deformed reinforcing bars. The tensile reinforcement in the pullout specimen consisted of No. 6 deformed bars, having either a barrel or diamond shaped deformation pattern, with a nominal yield strength of 60,000 psi. The length of embedment of the reinforcing bar in the concrete was 12 inches.</p> <p>The load or bond stresses corresponding to a loaded-end slip of 0.01 inch or a free-end slip of 0.002 inch were considered as critical values in determining the bond strength, depending on which of these values of slip developed first.</p> <p>For coating film thickness of approximately 10 mils or less, the epoxy-coated bars developed bond strengths essentially equal to the bond strengths for the uncoated bars. Experimental values of bond strengths for these coated bars were higher than minimum acceptable values given in building code and highway bridge requirements. Bond strengths of the polyvinyl chloride-coated bars and bars with thick epoxy coatings were unacceptable.</p>			
17. KEY WORDS (Alphabetical order, separated by semicolons) Bond strengths; concrete; epoxy coatings; polyvinyl chloride coatings; pullout tests; steel reinforcing bars			
18. AVAILABILITY STATEMENT <input type="checkbox"/> UNLIMITED. <input checked="" type="checkbox"/> FOR OFFICIAL DISTRIBUTION. DO NOT RELEASE TO NTIS.		19. SECURITY CLASS (THIS REPORT) UNCLASSIFIED	21. NO. OF PAGES 28
		20. SECURITY CLASS (THIS PAGE) UNCLASSIFIED	22. Price

