

NBSIR 73-148

Evaluation of the Column Connections Used in a Precast Concrete Modular Housing System

Felix Y. Yokel and Thomas W. Reichard

Center for Building Technology
Institute for Applied Technology
National Bureau of Standards
Washington, D. C. 20234

March 26, 1973

Final Report

Prepared for
Office of Research and Technology
Department of Housing and Urban Development
Washington, D. C. 20410

**EVALUATION OF THE COLUMN CONNECTIONS
USED IN A PRECAST CONCRETE MODULAR
HOUSING SYSTEM**

Felix Y. Yokel and Thomas W. Reichard

Center for Building Technology
Institute for Applied Technology
National Bureau of Standards
Washington, D. C. 20234

March 26, 1973

Final Report

Prepared for
Office of Research and Technology
Department of Housing and Urban Development
Washington, D. C. 20410



U. S. DEPARTMENT OF COMMERCE, Frederick B. Dent, Secretary

NATIONAL BUREAU OF STANDARDS, Richard W. Roberts, Director

Evaluation of the Column Connections
Used in a Precast Concrete Modular Housing System

by

F. Y. Yokel and T. W. Reichard

Abstract

The column connections used in a housing system employing stacked precast concrete box modules were tested to evaluate their structural performance. The system was proposed for construction in Operation BREAKTHROUGH, a research and demonstration program sponsored by the Department of Housing and Urban Development. The system uses innovative structural design concepts, which include: confinement of the concrete in the vicinity of the column bearings by reinforcing ties in order to increase concrete compressive strength; neoprene pads between column bearings in the upper stories, stories; steel-neoprene-steel sandwich in the lower stories; and a grouted dowel through the center of the columns to provide resistance to tension and shear.

The test program included the following: tests to determine the effect of various bearing pads on the load capacity of the connection; tests to determine the load-deformation characteristics of the neoprene pads; a test to determine the performance of a lower-story connection using a steel-neoprene-steel sandwich and a grouted dowel; and tests to evaluate the strength and ductility of the connections when subjected to a shear force. The test results are presented and interpreted and the findings are summarized.

Key Words:

Building system, column connection, concrete triaxial strength, ductility, neoprene bearing pad, performance test, precast concrete, structural design, Operation BREAKTHROUGH.

SI Conversion Units

In view of the present accepted practice in this country for building technology, common US units of measurement have been used throughout this paper. In recognition of the position of the United States as a signatory to the General Conference on Weights and Measures, which gave official status to the metric SI system of units in 1960, assistance is given to the reader interested in making use of the coherent system of SI units by giving conversion factors applicable to US units used in this paper.

Length

1 in = 0.0254 meter (exactly)

1 ft = 0.3048 meter (exactly)

Force

1 lb (lbf) = 4.448 Newton (N)

1 kip = 4.448 Newton

Pressure

1 psi = 6895 N/m²

1 ksi = 6.895 x 10⁶ N/m²

Table of Contents

Evaluation of the Column Connections Used in a Precast Concrete Modular Housing System

	Page
1. Introduction	1
2. The Building System	1
2.1 Description of System	1
2.2 System Features That Required Performance Evaluation	4
3. Scope	7
4. Tests	9
4.1 Bearing Capacity of Column Connections Using Various Types of Bearing Pads	9
4.1.1 Objective	9
4.1.2 Test Specimens	10
4.1.3 Test Procedure	11
4.1.4 Test Results	12
4.1.5 Discussion of Test Results	12
4.2 Tests to Determine the Load-Deformation Characteristics of the Neoprene Pads	16
4.2.1 Objective	16
4.2.2 Test Specimens	16
4.2.3 Test Procedure	16
4.2.4 Test Results and Findings	17
4.3 Tests to Evaluate the Bearing Capacity of Connections Using a Steel-Neoprene-Steel Sandwich as a Bearing Pad and a Grouted Dowel	18
4.3.1 Objective	18
4.3.2 Test Specimen	19

4.3.3	Test Procedure	20
4.3.4	Test Results	20
4.3.5	Discussion of Test Results	21
4.4	Test to Evaluate the Shear Capacity of Column Connections	25
4.4.1	Objective	25
4.4.2	Test Specimen	26
4.4.3	Test Procedure	26
4.4.4	Test Results	28
4.4.5	Discussion of Test Results	29
5.	Summary of Findings	33
6.	Acknowledgement	35
7.	References	36
8.	Tables	38
9.	Figures	42

Evaluation of the Column Connections
Used in a Precast Concrete Modular Housing System

by
F. Y. Yokel and T. W. Reichard

1. Introduction

The introduction of industrialized building systems may lead to the development of untried structural details which cannot be evaluated by analysis based on our present design standards. Whenever deviations from design standards are proposed, the structural adequacy of the system must be determined by performance evaluation.

This report presents the results of the performance evaluation of innovative column connection details in a multi-story housing system employing stacked precast reinforced concrete box modules which was one of the systems proposed for construction under the Operation Breakthrough program, sponsored by the Department of Housing and Urban Development.

2. The Building System

2.1 Description of System

The proposed system consisted of precast reinforced light-weight concrete box modules, stacked in a checkerboard pattern. Figure 2.1 shows one of the buildings proposed for construction, a 19-story structure. Figure 2.2 shows the model of a complex of buildings which is under construction using the structural concepts and connection details evaluated in this report, however, the modules differ in size and configuration from those proposed for the structure shown in figure 2.1.

A sketch of a proposed module is shown in figure 2.3. The outside dimensions of the module are 44 ft x 14 ft x 8 ft-11 in. The concrete used in the modules consists of a regular-weight sand and light-weight coarse aggregate mix with a unit weight of 120 lb/ft³ and a 28-day strength ranging from 4000 psi (lb per in²) to 5000 psi as specified in the design. An individual module of this type weighs 81.3 kip (kilopounds). Some of the boxes in the proposed system have balconies cantilevering from one, or both ends. A box with balconies on both ends, which is the largest module used in the system, is 52 ft long and weighs 92.3 kip.

The structural skeleton of the modules is shown schematically in figure 2.4. A module contains four bents (ribs) which are rigid frames consisting of 12 x 15 1/4-in^{1/} columns and 12 x 12-in^{1/} beams near the module ends, and 12 x 12-in^{1/} columns, with a 8-in thick slab section providing a common beam to both ribs at the center of the module. The bents are connected by a 4-in thick top slab, 3-in thick sidewalls, and a 4 in thick bottom slab. The bents, top slab, and sidewalls are cast monolithically in a single operation using a steel form creating a "hull". The bottom slab, which is cast in a second casting operation is attached to the hull by bent dowels protruding from the bottom of the sidewalls and by special steel inserts welded to the four center columns. The modules are erected in a checkerboard pattern as shown in figure 2.5. Part of the living space is contained within the modules and part is space created between adjacent modules. The space within modules provides a clear height of 8 ft-3 in and a clear width between concrete wall surfaces of 12 ft-6 1/2 in. The created space has the same clear height and a clear width of 12 ft-11 1/2 in between the concrete surfaces of the sidewalls. The structure is completed as shown in figure 2.6 by inserting special end wall, roof, and floor panels to complete enclosure of the created spaces.

^{1/} Since column and beam sections have flared sides (they are not exactly rectangular or square), average dimensions are given which represent equivalent rectangles or squares.

The method of connecting modules is illustrated schematically in figure 2.7. The entire load is transmitted through the columns. Transmission of load between the sidewalls in consecutive modules is prevented by suitable structural detailing. Anchorage through the column connections is provided by grouted dowels consisting of consecutive lengths of #8 (1 in diameter) deformed steel reinforcing bars, with a 60 ksi minimum yield strength, extending from midheight of one module to the midheight of the module above.

Details of the proposed column to column connection are shown in figures 2.8 and 2.9. Figure 2.8 shows the detail of an interior column joint. The heavy lines show the column and part of the floor slab of Module A, and column and part of the 8-in thick slab connecting the interior column bent in Module B. The dashed lines show the location of the roof and wall slabs. Note that the bottom of the floor slab extends $2 \frac{3}{8}$ in below the bottom of the column and that the column connection is located in a $2 \frac{3}{8}$ -in deep recessed pocket. The top of the ceiling in Module B is thereby located approximately at the same elevation as the top of the slab in Module A, thus eliminating the need for a stepped transition. It can also be seen that the wall of Module A does not bear on the wall of Module B. Thus all compressive and shear forces are transmitted through the bearing pad in the column connection. The joint between the boxes at locations other than the column connection contains a compressible filler material. Proposed connection details are shown in figure 2.9. Figure 2.9(a) shows the reinforcement near the column end where additional confinement ties are provided in the vicinity of the joint. Figure 2.9(b) shows a section through a connection.

Erection of the system proceeds in the following manner. Modules are precast in a plant, not too distant from the erection site, and transported to the erection site on specially-designed trailers. A 50-ton crane unloads the modules and lifts them to their desired position. Tolerances in fit to insure proper load distribution between the eight bearings are within limits that can be accommodated by the compressible bearing pads. Leveling during erection is achieved by inserting steel shims to bring all bearing pads to a level position before a module is placed. At the end wall of the building grouting proceeds continuously during construction to prevent instability of the sidewall panels enclosing the created spaces. All interior joints are grouted only after completion of the erection sequence.

2.2 System Features That Required Performance Evaluation

The proposed system differs in several ways from conventional cast-in-place reinforced concrete structures: (1) Reinforcement details differ from those normally used in column-beam connections. The unconventional details were required because of discontinuities between modules in the structure, the thin concrete sections and the rather heavy reinforcement, together with the need for an arrangement of reinforcing bars that would not impede efficiency in the mass production of modules, (2) All the vertical and horizontal forces are transmitted across the column connections which were planned to be "dry" connections to facilitate cold-weather construction and which include compressible bearing pads to accommodate construction tolerances.

The specific objective of this evaluation was to determine the load capacity of the column connection which had several

unique details. The various parameters considered in the evaluation of these details are discussed below:

1. Except for the No. 8 dowel, vertical column reinforcement is interrupted at the connection. Thus, the forces resisted by columns containing up to 3 percent vertical reinforcement, are transmitted through a plain concrete bearing with a single grouted dowel in its center. The maximum load permitted in such a bearing by ACI-318.71 [1]^{2/} would be exceeded in the bearing. It has been shown [2,3,4,5] that the compressive strength of concrete under triaxial confinement is greater than the unconfined compressive strength and the design therefore provides for additional ties in the vicinity of the joint as shown in figure 2.9(a). To permit a bearing stress in excess of that permitted by ACI-318 the load capacity of bearings was evaluated by testing.

2. In order to accommodate erection and fabrication tolerances, a 1/4-in thick neoprene pad is inserted between the columns. Available data on neoprene bridge bearings [6] are limited to stress levels less than 1000 psi, which are substantially lower than the 6000 psi stress developed in the proposed bearing at the failure load and are based on tests of neoprene pads bonded to steel plates. At the stress levels expected to occur when the required load capacity is reached the modulus of elasticity of neoprene is lower than that of concrete, and Poisson's Ratio is higher. The neoprene, therefore, exerts a splitting force on the concrete column faces, reducing the load capacity of the bearing[7]. Thus while the concrete capacity is increased by the confinement ties, as previously discussed, the beneficial effect of the confinement may be offset by the splitting force exerted at the concrete-neoprene

^{2/} Numbers in brackets designate literature references.

interface. This effect also had to be evaluated by testing.

3. Since it was recognized that the neoprene would reduce the capacity of the bearing, another type of bearing pad was proposed for the more heavily loaded bearings. This pad consists of a steel-neoprene-steel sandwich, using \pm 1/8-in thick (11 ga.) stainless steel plates and a 1/4-in thick neoprene pad. In this case it was assumed that the steel plate would act to resist the radially tangential shear exerted by the neoprene and to provide additional triaxial confinement at the steel-neoprene interface. This type of bearing also had to be evaluated by testing.

4. In addition to the information on the load capacity of the connection in compression, the deformation characteristics of the connection under compressive load had to be determined in order to compute the added horizontal drift under wind load caused by the compressible bearings.

5. The load capacity of the joints containing the grouted dowel had to be determined. The sequence of grouting in the construction had to be considered in this determination. As previously noted, the dowels in the columns near the side (gable) walls of the building are continuously grouted during construction (whenever a story is complete, the dowel is grouted). This procedure differs from the grouting procedure proposed for the other columns which is to grout in a single lift after completion of the erection. As a result of the continuous grouting, most of the load in the sidewall connections would be transferred to the dowel and surrounding grout, rather than to the compressible pad. This may cause crushing of the grout and yielding of the dowel in the lower stories of the building. These effects were not judged to be detrimental, since they would be confined to the vicinity of the compressible pad which is only 1/4 in thick in the uncompressed state.

However, this loading condition had to be simulated in the performance evaluation.

6. In addition to the load capacity in compression, the shear capacity of the connection had to be evaluated. The shear capacity is critical in the resistance of the building to wind and earthquake load and for the specific buildings under consideration, shear capacity was critical in the prevention of progressive collapse under abnormal loads. In the determination of shear capacity the previously-discussed effect of continuous grouting had to be simulated. In view of the use of compressible pads, displacements across the joint (slippage) had to be evaluated in addition to shear capacity. Not only the capacity of the joint in shear, but also the ductility of the joint was evaluated. Ductile behavior would prevent the premature failure of a single joint in a group of joints, thus increasing the load capacity of the building, and would also be an important consideration in determining the resistance to seismic loading. Special consideration was given to load reversals that may be caused by seismic events.

3. Scope

The results and conclusions from four different test programs are presented in this report. A slightly scaled-down column cross section (10 in x 12 in) was used in order not to exceed the capacity of the testing equipment.

- (1) Tests to evaluate the bearing capacity of column connections using various types of bearing pads (specimens did not have grouted dowels).

This program had two phases: In Phase I, two specimens consisting of two 10 x 12 x 31 1/2-in long column stubs with 1/4-in thick neoprene pads were tested in compression.

Subsequently, one of these stubs which did not fail in the initial test was bedded in high-strength plaster on a steel bearing plate and retested in compression.

In Phase II nine specimens, consisting of two 10 x 12 x 51 1/2-in long columns, were tested in compression. Eight specimens with various proposed types of bearing material inserted between the two stub columns and one specimen using a steel-neoprene-steel sandwich with low-friction membranes inserted between the neoprene and the steel plates were also tested.

Subsequently, one of the stub columns which did not fail in the initial test was tested bearing on a steel plate with a low-friction membrane inserted between the column face and the steel plate.

- (2) Tests to determine the stress-strain characteristics of neoprene pads.

In this test three specimens consisting of two 1/4-in thick neoprene pads each were tested in compression between steel plates and their load-deformation characteristics were recorded up to a stress level of 4000 psi.

- (3) Tests to evaluate the bearing capacity of connections using a steel-neoprene-steel sandwich as a bearing pad and a grouted dowel.

In this test one pair of 10 x 12 x 51 1/2-in long column stubs, using the connection details planned for the lower stories, was tested in compression using the most critical preloading condition before grouting of the dowel (simulating continuous grouting).

- (4) Tests to evaluate the shear capacity of the column connection.

Under this program three tests were conducted on three-segment specimens, using 10 x 12 x 51 1/2-in long column segments with the proposed connection detail between them. Specimens were tested by applying a shear force to push out the middle segment.

Two specimens were tested in shear while subjected to low axial load, simulating upper-story conditions. One of these was tested in one direction while the other was subjected to several reverse cycles of loading.

The third specimen was tested in shear while subjected to high axial load, simulating lower-story conditions. This specimen was subjected to several reverse cycles of loading.

4. Tests

4.1 Bearing Capacity of Column Connections Using Various Types of Bearing Pads

4.1.1 Objective

The problems associated with the load transmission from column to column are discussed in Section 2.2. The objective of this particular test program was to determine the failure load of bearings using additional column ties in the vicinity of the joint in order to provide triaxial confinement for the concrete and using various types of bearing pads proposed or considered as alternates. This test was necessary, since:

(1) the design concrete stress at the bearing surface, used in the lower-story joint, exceeded that permitted in ACI-318;

(2) the effect of the radially tangential shear force exerted by the neoprene on a neoprene-concrete interface could not be determined by analysis.

(3) there was a need to substantiate the effect of the steel plates in the proposed steel-neoprene-steel sandwich in triaxially confining the concrete and resisting the radially tangential shear force exerted by the neoprene.

The tests were conducted during the design stage of the system and served as exploratory (pilot) tests. The grouted dowel was omitted in these tests to avoid introduction of an added variable. After sufficient preliminary information was available from these tests, another test was conducted on a connection which included the grouted dowel.

4.1.2 Test Specimens

The typical specimen for these tests consisted of two column stubs placed end to end with the joint materials separating the two concrete bearing surfaces. For two of the tests single column stubs were used as the specimen.

Two types of stub columns were used. The first type, 10 in x 12 in x 31 1/2 in high, was used in the series of tests identified as Phase I tests. The second type, 10 in x 12 in x 51 1/2 in high, was used for the Phase II tests. The Phase I stub column is shown in figure 4.1 and the Phase II column in figure 4.2. The main reinforcement was welded to a 1 1/2-in thick steel plate at one end. Load was applied through the steel plate and the welded reinforcement connection insured that the load would be transferred simultaneously to the concrete and the main reinforcement. The Phase II columns exclusive of the steel bearing plate were 1/2 the length of the column in the proposed structure.

Typical details of the test specimens are shown in figure 4.3. Main vertical column reinforcement consisted of deformed steel bars meeting ASTM designation A615-68, Grade 60 [8] and had an average measured yield strength of 67.4 ksi (tensile tests were conducted in the laboratory). Ties were deformed bars meeting ASTM designation A615-68, Grade 40 and had an average measured yield strength of 51 ksi.

The welded wire mesh cage shown in the figure corresponds to the detail in the system used to prevent concrete breakage caused by form stripping. The welded wire mesh had an average yield strength of 63 ksi according to information obtained from the manufacturer.

The concrete in all specimens was a 4000 psi mix using sanded lightweight aggregate of 3/4 in maximum size. Figure 4.4 shows the age-strength relationship for these concretes.

The types of jointing materials used in these tests are described in table 4.1.1.

4.1.3 Test Procedure

All specimens were loaded in a 600 kip hydraulic testing machine. The specimens were preloaded to 200 kip (1670 psi) unloaded and subsequently loaded at 75 kip (62.5 psi) per minute until failure. The failure was not sudden, in that considerable splitting and spalling occurred prior to the decrease in load resistance. Application of load was continued past the point of maximum resistance until the load fell off to 80 - 90 percent of the maximum.

The method of load application is shown in figure 4.5. The specimen was positioned concentrically with respect to the applied load, with its base set on the testing machine platen in a bed of high strength gypsum plaster. The load was applied by the spherically-seated head of the testing machine which was fixed against rotation after applying a compressive load of 1 kip. A 1/2-in thick fiberboard plate was inserted between the steel plate at the surface of the specimen and the head of the testing machine. This setup resulted in approximately concentric loading.

In the Phase II tests the vertical deformation of the joint material was monitored by means of a 0.001-in dial gage. Lateral deformations were measured over a 9-in gage length using linear variable differential transducers. These

deformations were monitored by X - Y recorders with a resolution of 0.001 in to aid in the determination of the onset of spalling (see figure 4.1).

4.1.4 Test Results

The results for all the tests are presented in tables 4.1.2, 4.1.3 and 4.1.4. Typical failure modes are illustrated in figures 4.5 through 4.9.

4.1.5 Discussion of Test Results

In tables 4.1.2 and 4.1.3 the results are normalized by dividing the ultimate load by $0.85 f'_c A$, where:

f'_c is the average concrete compressive strength of 6 x 12-in cylinders taken during the casting of the specimens and tested at the time the specimens were tested.

A is the cross sectional area of the column.

$0.85 f'_c A$ is the failure load of a plain concrete bearing with no reinforcement ties to provide confinement, computed in accordance with ACI 318-71. In the case of Test 6 of Phase II of this testing program, A was taken as 80 in² accounting for the 2-in eccentricity from the major axis.

By normalizing the loads in this manner a strength coefficient (k) is computed which represents the ratio of the strength of the test specimens to the strength of a plain concrete bearing with no confinement and no splitting effects exerted by neoprene pads. Examination of the strength coefficients in the last columns of Tables 4.1 and 4.2 leads to the following observations:

(1) In spite of the confining reinforcement, the average strength of the plain neoprene bearing tended to be less than that estimated for an unconfined concrete bearing (Tests 1 and 2, Phase I; Test 1, Phase II).

(2) The strength of the connection using the steel-neoprene-steel sandwich with the 11 ga. (gage) steel plate tended to exceed the strength estimated for a plain concrete bearing by approximately 30 percent (Phase II, Tests 4, 5, and 6). With the 16 ga. steel plates the strength was reduced to 11 percent over that estimated for a plain concrete bearing (Phase II, Test 8); however, when low-friction membranes were inserted between the neoprene and the steel plates, the strength increased to 20 percent overstrength (Phase II, Test 9).

(3) The two grouted specimens exceeded the estimated strength of an unconfined plain concrete bearing by 12 to 26 percent (Phase II, Tests 2 and 3).

(4) The column stub with the low-friction membrane exceeded the estimated strength of an unconfined plain concrete bearing by 20 percent, while the stub set in high-strength plaster on a 1-in steel plate exceeded the estimated strength by 56 percent.

Note that in Tests 5, 6, 8, and 9 the size of the neoprene pad was smaller than that of the bearing area. This size reduction was to prevent excessive extrusion of the neoprene from the sides of the bearing. Since under pressure the lateral dimensions of the neoprene pad increased and extended over the entire bearing area, there was no apparent adverse effect from the decrease in the size of the neoprene pad.

It can be concluded from these observations that the radially tangential force exerted on the concrete bearing surface has a major effect on the capacity of the joint. The specimens ranged from those where the joint exerts a splitting force on the surface to those where the joint is capable of developing a significant confining force.

At one extreme is the neoprene bearing pad which exerts a splitting force on the concrete counteracting the confining effects of the reinforcement ties.

The specimens bearing on low friction surfaces, as well as the grouted specimens probably did not develop significant radially tangential shear forces on the concrete bearing surfaces (in the latter case Poisson's Ratio and the Modulus of Elasticity were similar for concrete and grout). Thus, the k-coefficient for these specimens which averages approximately 1.2, probably represents the effect of the confinement provided by the reinforcement ties.

The steel-neoprene-steel sandwich using the 11-ga. steel plates, where the k-coefficient averaged 1.32 exerted a confining force which prevented concrete splitting and was transmitted by the friction between the concrete and the steel plate and resisted by the steel plate. The steel plate also resisted the additional splitting force exerted by the neoprene pad. The 16-ga. steel plates which yielded during the test did not have sufficient strength to resist the splitting force.

The greatest confining force was provided by the steel plate set in the plaster where a confining force greater than that provided by the frictional resistance of the steel/concrete interface could be developed. This additional confining force increased the k-coefficient to 1.56.

The previous conclusions are based on both Phase I and Phase II testing. Originally the longer column stubs used in Phase II testing were used because there was concern that the short length of the Phase I columns might be insufficient to develop the bond between the concrete and the main column reinforcement. The tests, however, do not provide evidence that the change in column length had a significant effect on the mode of failure or on the load capacity. The conclusions are also based on the assumption that, except for Test 6 in Phase II, the applied load was approximately concentric.

The effect of the type of bearing pad on the mode of failure can be observed in figures 4.5 to 4.9.

Figure 4.5 shows a typical failure of a connection using a neoprene pad. The spalling between the core inside the ties and the shell outside the ties is an indication that at ultimate load the core supported most of the load. The same observation can be made in figure 4.6 which shows the typical failure of a grouted connection.

On the other hand, it can be seen from figure 4.7 that in the specimens using the steel-neoprene-steel sandwich there was no spalling of the shell, and thus, the entire cross-sectional area contributed to the load resistance. It can also be seen in this figure that the concrete bearing surface is smooth and locally deformed with protruding imprints of the main reinforcing bars. The deformation is probably attributable to plastic flow of the concrete before failure which is taken as an indication of triaxial confinement. The imprint of the bars was caused by bond breakage near the end of the bars where the strain in the concrete could not be transmitted to the steel bars.

The failure of the column stub that was bedded in high-strength gypsum plaster, which is shown in figure 4.8, occurred in the middle of the column above the region of the additional confining ties. This is taken as an indication that in this case the effect of the confinement was even greater than that provided by the steel-neoprene-steel sandwich. On the other hand, the failure mode of the column stub which was tested with a low-friction membrane at the column face and is shown in figure 4.9, gives clear evidence of spalling of the shell.

Thus, in summary, it is concluded that the radially tangential shear force exerted on the concrete face at the interface with the bearing pad had a significant effect on the bearing capacity of the column connection. The coefficients shown in the last column of 4.1.2 and 4.1.3 give an indication of the magnitude of this effect.

4.2 Tests to Determine the Load-Deformation Characteristics of the Neoprene Pads

4.2.1 Objective

The modulus of elasticity of neoprene generally tends to increase as compressive stresses in the neoprene are increased [6]. The load-deformation characteristics of a neoprene bearing pad depend on its shape and on the properties of interfacing materials.

The objective of these tests was to determine the load-deformation characteristics of the proposed neoprene pads. This information could be used in improved analytical models for the prediction of joint deformation characteristics and for the assessments of the effect of dimensional inaccuracies on the distribution of loads between columns. A secondary objective was to arrive at an estimate of the magnitude of the lateral expansion of neoprene bearing pads when subjected to compressive load.

4.2.2 Test Specimens

All specimens were 1/4 in thick, and made of 70 durometer neoprene pad materials. Four 9 x 11 x 1/4 in specimens were used in two tests. Each of these four full-sized specimens was tested with a 2-in diameter hole in the center. In an additional test two half-sized specimens (9 x 5 1/2 x 1/4 in) were tested without center holes.

4.2.3 Test Procedure

All tests were made in a hydraulic testing machine by loading the specimens through a 2 1/2-in thick bearing block. In each test, two pads were sandwiched between three 2 1/2-in thick steel blocks as shown in figure 4.10. Thus,

two pads were tested in each test. The size of the steel blocks used was as shown in figure 4.10. The bearing surfaces of the steel blocks were ground flat in a tub-grinder. Deformation measurements were made on the four sides of each pad using dial gages with a 0.001-in resolution and were referenced to the platen of the testing machine. Compressive deformations were measured in Tests 1 and 2 and lateral expansion deformations were measured in Test 3. Full-sized pads were used for Tests 1 and 3 and the half-sized pads were used for Test 2.

Prior to each test the specimens were preloaded to the maximum test load for 10 minutes in order to reduce creep effects during the test. The specimens were tested immediately after removal of the preload and loaded at a slow average rate because of the interruptions necessary for dial gage reading. Gage readings were taken for each load increment after a compression was reached that could be maintained in a stable position while the readings were taken.

4.2.4 Test Results and Findings

Figure 4.11 presents the data from Tests 1 and 2. The deformations are the average for the eight measurements on the two specimens in each test. The effect of the shape factor of the pad on the compressive deformation is quite apparent from this figure. For load levels above 100 kip the deformation of the full-sized pad is only 58 percent of that for the half-sized pad. It is also apparent from figure 4.11 that the modulus of elasticity for these pads increases with increasing stress.

Figure 4.12 is a plot of compressive stress (based on the 9 x 11-in area) versus tangent modulus of elasticity for the full-sized pad. This plot shows that the tangent modulus at 4,000 psi is over 6 times the initial tangent modulus.

In all of the tests the lateral expansion of the pad was non-uniform; i.e. the pad was extruded from the steel blocks significantly less at the corners than at mid-length and width. At high stress levels the pad assumed a roughly elliptical shape. In Test 3 an attempt was made to measure the lateral extrusion of the full-sized pad using dial gages. Because of the out of plane distortion of the pads the measurements only approximately convey the magnitude of this effect. Figure 4.13 shows the extrusions measured for various load levels. The extrusions plotted are the arithmetic means of 8 measurements made on 2 specimens. The measurements were made at the center of each side so that the extrusions are maximum values.

As stated above, all test results were obtained after applying a preloading cycle immediately before the load application for which deformations are recorded. Since the visco-elastic properties of the material may delay load recovery it is reasonable to expect somewhat greater deformations in the initial load cycle. Thus the data presented would more accurately predict load-deformation relationships for interior column connections which are preloaded before grouting of the dowel.

In Table 4.1.4 data obtained in this test are compared with measurements of compressive deformations of pads in Phase II of the bearing tests on column connections. Even though in the Phase II tests preloading was only 200 kip, there is reasonable agreement between the test results discussed herein and the measurements in the Phase II tests.

4.3 Tests to Evaluate the Bearing Capacity of Connections Using a Steel-Neoprene-Steel Sandwich as a Bearing Pad and a Grouted Dowel

4.3.1 Objective

The objective of this test was to evaluate the capacity of the connection as proposed for the lower story containing

the grouted dowel and the steel-neoprene-steel sandwich. The most critical condition with respect to the dowel was simulated, namely, continuous grouting. This was achieved by preloading with an axial load of 10 kip before grouting which simulated the weight of a single story. This preloading condition could cause the dowel to yield before occurrence of a compression failure in the concrete. The effect of such premature yielding, together with crushing of the grout and bond breakage between the dowel and the grout in the vicinity of the neoprene pad, could not be predicted.

4.3.2 Test Specimen

The test specimen shown in figure 4.14, consisted of two 51 1/2-in high stub columns similar to those described in section 4.1.1. However, these stub columns, as shown in the figure, had five confinement ties instead of the three used previously. This change was made because of a design change in the proposed system. In addition, a 2-in round flexible conduit was cast in the center of each stub. The hole formed in the column by the conduit was for the #8 deformed reinforcing bar (ASTM A615-68, Grade 60 Steel) used as the dowel.

The two stubs were placed end to end with the steel-neoprene-steel sandwich joint separating the two concrete bearing surfaces. The length of the dowel inserted through the holes in the two stubs was slightly longer than the overall length of the two stubs (103 in). The six externally threaded 1-in diameter steel bars, which can be seen in figure 4.14, were used to apply a 10 kip axial preload to the specimen before grouting and to sustain the preload until testing.

The grout was type III portland cement and water mixed at a water-cement ratio of 0.4. The concrete in the column stubs was as described in section 4.1.2.

4.3.3 Test Procedure

The test was performed in a 600-kip hydraulic testing machine. Load was applied in 25-kip increments and maintained after each increment for electronic recording of measurements. Loading was continued to the 600 kip level. The 600-kip load (maximum testing machine capacity) was maintained for 12 minutes. Then the specimen was unloaded, reloaded to 600 kip in three 200-kip increments, maintained at 600 kip for two minutes and unloaded.

The load was applied concentrically as shown in figure 4.14. The steel plates at the ends of the specimens as well as the loading plates had a 2-in hole in their center to prevent direct load transfer to the steel dowel. The preloading bars were left on the specimen during the test. Displacement transducers as shown in figure 4.15, were used to measure the deformation of the joint during the test. Bonded-foil strain gages were used to measure the strain on two opposite sides of the dowel in the center of the joint and also the strain in the concrete directly over each of the five confinement ties on two adjacent faces of one column stub (see figure 4.15).

4.3.4 Test Results

The test results are given below:

Maximum Load:	600 kip
Loading Condition:	Concentric (figure 4.14)
Concrete Compressive Strength:	(6 x 12 in cylinders) 3930 psi
Grout Compressive Strength:	(2 x 2 in cubes) 11,000 psi
Condition After Testing:	Minor cracking

Joint deformation data are shown in figure 4.16. Strain data for the dowel and typical strain data for the concrete over the confinement ties are shown on figures 4.17, 4.18 and 4.19.

4.3.5 Discussion of Test Results

(1) Load Capacity

It is noted in section 4.3.4 that the test load was limited by the 600-kip capacity of the testing machine. The maximum test load was maintained for a 12-minute period and, after an unloading and reloading cycle, for another 2-minute period. The specimen experienced some cracking as shown in figure 4.15, but did not lose its ability to support the 600-kip load. On the basis of this evidence it may be assumed that the ultimate load would have exceeded 600 kip.

Strain data from the gages on the column faces are plotted in figures 4.18 and 4.19. On the basis of the characteristics of the load-strain relationship and the magnitude of strain it appears that significant cracking in the concrete occurred above the 350-kip load level. Very large apparent^{3/} strain developed at load levels above 500 kip. Three of the gages failed at 475, 525 and 600 kip respectively, probably as a result of severe cracking; gage 18, the closest to the joint, survived the entire load cycle. While the 600-kip load was sustained this gage showed a substantial increase in apparent strain (from 0.0059 to 0.0107). After removal of the load the gage returned to a residual strain of 0.0082. A similar trend is shown by the strain gage data on the other instrumented column face which are shown in figure 4.19. In this case all the gages failed between the 500 and 600 kip load levels. Thus, it can be concluded from the strain gage readings that substantial cracking occurred above the 500-kip load level and during the time the 600-kip load was maintained.

^{1/} The term apparent is used since cracking was mostly responsible for the observed deformation.

Figure 4.16 shows the length change in a 11-in vertical column segment which includes the joint at its center. It can be seen in this figure that substantial "creep" occurred while the 600-kip load was maintained. As noted in the subsequent discussion, much of this length change was attributable to concrete deformation rather than joint deformation.

The previously discussed trends in measured deformations are taken as an indication of incipient failure at the applied test load of 600 kip. Thus while the load capacity of the specimen exceeded the 600-kip test load, it probably did not exceed that load by a substantial margin. Using the concrete strength of 3930 psi, a dowel capacity at yield of 53 kip (based on the 67.4 psi yield strength), and a k-coefficient of 1.32 for the confining effect of the steel-neoprene-steel sandwich (see section 4.1.4, Table 4.1.3, average k-coefficient for Tests 4, 5, and 6), a load capacity of 580 kip is predicted for this specimen.

It can be concluded on the basis of the previous discussion that the load capacity of the specimen exceeded the capacity predicted on the basis of the confining effect of the steel-neoprene-steel sandwich. It can also be concluded that yielding of the dowel, bond slippage, and local grout crushing apparently did not adversely affect the load capacity.

(2) Load Response Characteristics

Figure 4.16 shows a plot of load versus the compressive deformation of an 11-in high segment of the specimen including the joint at its center. The deformations were measured at four column faces and it can be seen from the plot that there is reasonable consistency in the trend of these four measurements.

A definite break in the load-deformation curve occurred between the loads of 100 and 150 kip. Since the specimen was preloaded to 10 kip before grouting it is assumed that the initial 10 kip load is supported by the neoprene

pad. Subsequently, however, because of the low neoprene stiffness, most of the load was transferred to the steel dowel and the 2-in diameter grout column surrounding it. This mechanism of load transfer had to eventually break down by breaking of the bond between the dowel and the grout in the vicinity of the joint and by crushing of the grout column surrounding the dowel in the region of the 1/4-in neoprene pad. The break in the load-deformation curves is probably attributable to this change in the load transfer mechanism. Dowel yielding is ruled out on the basis of the strain measurements in the dowel at the 100-kip load level.

At the 600-kip load level there was substantial additional deformation during the period when the 600-kip load was sustained. Some of this deformation may be attributable to creep of the neoprene pad; however, in view of the large increase in transverse concrete strain shown in figures 4.18 and 4.19, it is reasonable to assume that most of this deformation was attributable to cracking of the concrete. This contention is supported by the large residual deformation after removal of the load. This residual deformation was approximately 0.21 in. The total deformation of the neoprene pad, when subjected to a 550-kip load, (50 kip would be carried by the dowel) is not expected to exceed 0.1 in (extrapolation from Table 4.19 and figure 4.11); and even though recovery of some of this deformation may have been prevented by a permanent set in the dowel and by visco-elastic time lag, most of the 0.21-in residual deflection should be attributable to the concrete compressive deformation.

Figure 4.17 shows the strain measured in the dowel over a 1/4-in length centered in the center of the joint. Very little strain was recorded during the first 20 kip of loading. This is in part attributable to the 10-kip preload which prevented significant load transfer to the dowel during the first 10-kip load increment. The subsequent relationship

between strain and compressive load leads to the conclusion that up to the 100-kip load level the dowel transmitted only part of the load. At the 100-kip load level the approximate load transmitted by the various components of the system is estimated as follows on the basis of the data in figures 4.17 through 4.19: The average strain in the steel was 0.009 which corresponds to a 22-kip load acting on the dowel. The neoprene pad is estimated to have supported approximately 30 kip. This leaves a 48-kip load to be supported by the 1/2-in high grout column. Such a load would be associated with a 20,000 psi stress in the grout which probably could be sustained because of triaxial confinement (cube strength of the grout was 11,000 psi). It is evident from figure 4.16 that some change occurred at the 100 kip level. Since dowel yielding is ruled out on the basis of the average dowel strain this change was probably caused by crushing of the grout and load transfer to the neoprene pad.

Between the load levels of 170 and 270 kip the dowel strain did not increase. A possible explanation for this observation may be provided by breakage of bond between the dowel and the surrounding grout in the vicinity of the connection which caused any additional load to be transferred to the neoprene pad. Dowel yielding may have contributed to this process, however the strain level at which dowel yielding is expected was reached at the slightly higher load of approximately 300 kip. No large vertical deformation was associated with dowel yielding since at the 300-kip load level most of the load was carried by the neoprene. After unloading the permanent set in the dowel corresponded to an average strain of 0.0048. In the re-loading cycle the dowel yielded at approximately 400-kip and the final permanent set in the dowel corresponded to an average strain of 0.0055.

The conclusion that can be drawn from the preceding discussion is that load transfer to the neoprene pads occurs at a load level of approximately 100 kip and is probably attributable to crushing of the grout column and limited breakage of bond between the dowel and the grout; and that dowel yielding occurs at approximately 300 kip and was not associated with a significant decrease in the vertical stiffness of the joint.

4.4 Test to Evaluate the Shear Capacity of Column Connections

4.4.1 Objective

Since all loads are transmitted through the column connection the shear capacity of the connection may be critical with respect to the resistance of the system to horizontal wind or seismic load. Because of the complex nature of the connection, the relatively low resistance of the neoprene pad to distortion under in-plane shear, and the effect of dowel yielding during construction, testing was used to determine load-deformation characteristics, load capacity and ductility of the connection.

The load-deformation characteristics were to provide information that could be used to evaluate the contribution of the joints to drift of the structure under wind and seismic load. Determination of ductility, including application of several cycles of reversed loading, was to provide important information with respect to required safety margins (a higher margin would be required if a single joint could fail and lose its load resistance before the other joints in the same story level are loaded to capacity) and with respect to structural response to seismic loading which is related to the ability of the joints to absorb energy.

4.4.2 Test Specimen

The test specimen for these tests consisted of three 1/2-story high (51 1/2 in long) stub columns which were connected end to end by a continuous grouted dowel using connection details previously described. The stub columns were similar to those described in section 4.3.2 except that there were 5 confinement ties at both ends of each stub column replacing the heavy steel plate used at one end of the stubs in the compressive tests. Figure 4.20 shows stub reinforcement and several column segments under construction.

A specimen arranged for preloading and grouting of the dowel is shown in figure 4.21. The three stub columns shown aligned in the figure were preloaded to 10 kip using an external bar system similar to that described in Section 4.3 before grouting a full-length dowel. This 10 kip preload was sustained until after the test for Tests 1 and 2. For Test 3 the external preload was increased to 90 kip after the grout had attained the specified compressive strength (5000 psi).

The joint for Tests 1 and 2 was a 1/4-in thick neoprene pad. For Test 3 the 11 ga. stainless steel neoprene sandwich was used.

The concrete and grout were similar to those described in section 4.3.2

4.4.3 Test Procedure

The test setup is shown in figures 4.22 and 4.23 for Test 1, and Tests 2 and 3, respectively. Shear load was applied simultaneously to both connections by applying lateral load to the center stub while the two end stubs were restrained from translation and rotation. Load was applied in the direction of the narrow dimensions of the columns. The tests were performed in a 600-kip hydraulic testing machine.

Joint displacement (slip) was measured electronically by vertical displacement transducers with a resolution 0.001 in and referenced to the laboratory floor. The displacement of the center segment was measured in Test 1 by two transducers mounted near each joint on either side of the segment and in Tests 2 and 3 by three transducers mounted in its centerline, two near the joints, and one in the center of the segment. In all three tests the two end segments were each instrumented by two transducers on either side of the segment near the joint and by one transducer in the centerline of the segment near the end of the specimen. Even though an attempt was made to keep the end segments in a fixed position, displacements up to 0.03 in were measured near the joints. Thus net joint slip had to be computed by compensating for these displacements.

In Test 3, axial dowel strain was measured by bonded-foil strain gages on two sides of the dowel in the center of each joint. The gages were arranged on the two sides of the dowel in a horizontal plane normal to the direction of loading to eliminate the effect of dowel bending. Dowel strain was also monitored during axial preloading. Loads were monitored electronically by pressure transducers connected to the hydraulic systems of the rams and the testing machine.

All data were electronically recorded after load increments varying from 5 to 20 kip. The displacements at one of the transducers of the center segment was also graphically monitored by an X-Y recorder to provide information on the behavior of the specimen and to aid in the determination of load increments. In Tests 2 and 3 the information from the X-Y plotter was used to determine the magnitude of the displacement excursion in each load cycle.

In Test 1 the lateral load was applied as shown in figure 4.22 in only one direction by the testing machine. In Tests 2 and 3 the lateral load was applied alternately in two directions by using the testing machine in one direction and hydraulic rams in the opposite direction. This second test set-up is illustrated in figure 4.23.

In Test 1 the center segment was loaded in increments until the + 1-in clearance prevented continuation of the test.

In Tests 2 and 3 reverse cycles of load were applied as shown in the following schedule.

Loading Schedule of Tests 2 and 3:

Cycle 1: 35^{a/} kip total lateral load in both directions
(down and up)

Cycle 2: Excursion of $2\Delta y$ ^{b/} in both direction (magnitude of load 50 kip maximum was determined by the requirement to produce the desired excursion).

Cycles 3 through 7: Excursions of $5\Delta y$ in both directions
(maximum load approximately 70 kip)

Cycles 8 and 9: 35 kip load in both directions

Cycles 10 through 14: Excursions of $5\Delta y$ in both directions

Cycles 15: Downward load to failure

The 90 kip axial preload in Test 3 was monitored and adjusted at the beginning of each load cycle.

4.4.4 Test Results

Figure 4.24 shows the Test 3 specimen after failure. Note the large slip at the joints, the extrusion of the neoprene and the cracked concrete near the upper left corner of the center segment. The two inset photographs show the appearance of the fractured dowel. The low-cycle fatigue fracture of the dowel originated at a defect (see inset in lower left corner) and was similar in appearance in both Test 2 and Test 3.

^{a/} 35 kip (17.5 kip per connection) was considered the highest load level at which the load-displacement relationship was still linear.

^{b/} Δy is the deflection at yield as determined from the X-Y plot. Each excursion was measured from the unloaded position at the completion of the previous load cycle.

Test results in the form of load versus displacement at one side of the center segment relative to the laboratory floor are shown in figures 4.25, 4.26 and 4.27. "Load" is the load on each connection which is 1/2 of the total applied load. Dowel strain caused by the axial loading of the Test 3 specimen is shown in figure 4.28. Strain gage 8 did not function. Figure 4.29 shows the dowel strain during Test 3 (including that caused by the preloading to 90 kip). Figures 4.30, 4.31, and 4.32 show the net joint displacement (slip) in Test 1 and the first half of the second cycle in Tests 2 and 3, corrected for the measured displacements of the end segments near the joints.

4.4.5 Discussion of Test Results

(1) Load Capacity

Test results for the connections subjected to low axial load are shown in figures 4.25 and 4.26. In figure 4.25 (Test 1) a change in stiffness similar to yield occurred at approximately 19 kip at a joint displacement of approximately 0.05 in. The test was discontinued at a 40-kip load when the joint displacement reached approximately 1 in. In Test 2 the load was applied in reverse cycles. In the first reverse load cycle the load was carried to 17.5 kip in either direction and there was substantial deflection recovery (over 80 percent). In the subsequent cycle yield occurred at approximately 25 kip. The envelope of the reverse load cycles in the direction of initial displacement (downward) is similar to the load-displacement curve in figure 4.25. At the failure load of \pm 37 kip the displacement was approximately 1.2 in. Thus the joint was able to resist 10 reversed load cycles with excursions equal to 5 times the initial yield deflection (initial yield deflection was \pm 0.1 in in Test 2) and failed at a final joint displacement equal to approximately 12 times the yield deflection.

Since Tests 1 and 2 were upper story simulations plain neoprene pads without steel plates were used. Figure 4.26 shows the result of shear tests on a connection using the steel-neoprene-steel sandwich and subjected to a 90-kip axial load. In this case the preload before grouting was 10 kip and the total axial load was increased to 90 kip before the shear force was applied. Even though it was anticipated that frictional resistance would affect the strength of this connection, yield occurred at approximately 20 kip and thus the yield strength did not differ from that of the specimens in the previously-discussed tests. Dowel fracture, however, occurred at a higher load level (62 kip) than in Test 2. As in Test 2 the response in the initial load cycle, carried to 17.5 kip in both directions, was substantially elastic (80 percent displacement recovery).

In both Test 2 and Test 3 the initial loading was in a downward direction. After the second load cycle a residual deflection in the downward direction remained after unloading. This downward drift increased progressively as additional load cycles were applied.

From the previous discussion the conclusion is drawn that the axial load applied during the shear test had no significant effect on the yield load in shear which was approximately 20 kip. The compressive strain in the dowel caused by the 90-kip axial load applied in Test 3 was approximately 0.0011 as shown in figure 4.28 which is within the range of strains recorded for a 90-kip axial load in figure 4.16 for the compressive test on the column connection with the grouted dowel. It has been noted in Section 4.3.5 that, in the compressive load test, load transfer to the neoprene occurred at compressive load levels above 100 kip. Thus it is reasonable to assume that the applied axial load was supported by the dowel and the surrounding grout column. Frictional resistance to sliding was, therefore, probably

mobilized only after the axial load was transferred to the neoprene, and did not affect the load resistance of the specimen up to the yield point. Since in the proposed structure only columns in the side walls are continuously grouted, and since these side-wall columns support only 1/2 the load acting on interior columns, it is anticipated that all joints in side-wall columns would develop a shear capacity of approximately 20 kip. Interior lower-story column joints, where the entire dead load is transferred to the neoprene before grouting, could be expected to develop greater yield strength when subjected to lateral load. The loading condition of interior joints was not simulated since it was not considered critical.

In summary it is concluded that the lateral load capacity at yield of upper-story joints and lower story side-wall joints is approximately 20 kip and that all joints failed in a ductile manner when subjected to reverse cycles of lateral load. The load capacity of interior joints is probably higher.

(2) Response to Lateral Load

Load-displacement characteristics are shown in figures 4.30, 4.31 and 4.32. Displacement at each joint was computed by compensating for the translation of the exterior segments of the specimen near the joint. Figure 4.30 shows the data for Test 1. Since there was considerable rotation in the north joint the measurement at the south joint is considered more reliable. The test data for Test 2 are shown in figure 4.31. In this case the transducer measuring the north joint displacement may have been obstructed since south joint displacements agree reasonably with the displacements at the center of the center section. Thus, in this case, the south joint measurements are taken as representative. In Test 3, shown in figure 4.32, there is good agreement between the displacement in both joints. The broken lines shown in Tests 2 and 3 approximately follow the envelope connecting the peak loads in the various cycles of downward load. In

figure 4.33 the three load-displacement curves are superimposed. Test specimens 1 and 3 had a similar load-displacement relationship up to the 20-kip load level. The Test 2 specimen had lesser stiffness, probably because it was subjected to a previous load cycle. Thus there is no indication that the magnitude of the axial load had any effect on the stiffness in the elastic range. After yielding occurred the Test 3 specimen developed greater stiffness than those in Tests 1 and 2.

Figure 4.29 shows the average axial dowel strain measured in Test 3. Only strain gage 7 is shown, since the data from the other strain gages were erratic. The erratic readings were probably caused by dowel bending and other disturbances in the connection. It appears that average axial yield strain was reached during the unloading cycle of cycle 2, which is after the completion of an excursion equal to twice the yield displacement. Thus, "yielding" in the load-displacement curve may be attributable to crushing of the grout column in the joint, and not necessarily dowel-yielding. This observation, however, should be qualified since the strain gage was located in the neutral axis of the dowel with respect to bending and, therefore, approximately measures net axial tensile strain rather than maximum strain, while initial dowel yielding may have been caused by bending rather than tension.

It can be concluded from the previous discussion that no correlation between axial load and stiffness in shear was observed prior to yielding. After yielding occurred the specimen subjected to the high axial load developed greater stiffness and strength. This observation is attributed to the effect of frictional shear which was not mobilized prior to compressive-load transfer to the neoprene.

5. Summary

(1) The compressive-load capacity of the column connection is affected by the radially tangential shear exerted by the bearing pad on the column face. The effect of the various types of bearing pads on the joint capacity is computed in the last column of Tables 4.1.2 and 4.1.3.

(2) A connection using a steel-neoprene-steel sandwich and a grouted dowel similar to that proposed to be used in the lower stories of the building systems had a load capacity which exceeded that predicted using the strength coefficient computed on the basis of column connection tests and tabulated in the last column of table 4.1.3.

(3) In a test specimen simulating the continuously-grouted column used in the plane of the side wall:

1. the load transfer from the dowel and the surrounding grout column to the neoprene pad occurred at the load level of approximately 100 kip. The load transfer mechanism was probably associated with crushing of the grout column in the connection space together with bond breakage between the dowel and the grout in the vicinity of the connection;
2. dowel yielding occurred at the approximate load level of 300 kip;
3. neither the initial load transfer to the neoprene nor the dowel yielding caused a sudden large increment of compressive deformation (a deformation which is not associated with an increase in load);

(4) The load-deformation characteristics observed in the tests on the neoprene pads presented in figure 4.11 are reasonably consistent with joint compression measured in the bearing tests on column connections and presented in Table 4.1.4.

(5) For three pairs of column joints subjected to combined axial compression and shear:

1. Yield in shear occurred at a lateral load level of approximately 20 kip per connection and the yield load was independent of the applied axial compression.
2. Up to the yield load in shear no correlation was observed between the applied axial load and the stiffness in shear (magnitude of slip displacement). After yielding, the connections subjected to high axial load developed greater stiffness in shear and their ultimate load capacity was greater than that of the connections subjected to low axial load.
3. The connections failed in a ductile manner under monotonic loading as well as under reversed cycles of loading.

The findings under 1 and 2, as related to connections subjected to high axial load, apply to the continuously-grouted columns in the plane of the side wall. Interior column connections where the entire dead load is supported by the neoprene pads could develop greater stiffness up to the yield load and yield at a higher shear load.

6. Acknowledgement

The authors wish to acknowledge the cooperation of the following persons:

Dr. Norman F. Somes; Mr. Frank A. Rankin; Mr. James F. N. Seiler; Mr. Charles Bulik; Mr. Randolph Williams; Mr. Thomas E. Ruschell; and Miss Cathy M. Glaze, Structures Section, Center for Building Technology, National Bureau of Standards.

7. References

- [1] American Concrete Institute, Building Code Requirements for Reinforced Concrete (ACI 318-71) American Concrete Institute, (Detroit Mich., 1970).
- [2] Richart, F. E., Brantzaeg, A., and Brown, R. L., A Study of the Failure of Concrete Under Combined Compressive Stresses, Bulletin 185, University of Illinois Engineering Experimental Station, (Urbana, Ill., 1928).
- [3] Richart, F. E., Brantzaeg, A., and Brown, R. L., The Failure of Plain and Spirally Reinforced Columns in Compression Bulletin 190, University of Illinois Experimental Station, (Urbana Ill., 1929).
- [4] Blume, J. A., Newmark, N. M., and Corning, L. H., Design of Multistory Reinforced Concrete Buildings for Earthquake Motion, Ch. 5, Portland Cement Association, (Chicago, Ill., 1961).
- [5] Somes, N. F., Compression Tests on Hoop-Reinforced Concrete, Journal of the Structural Division Proceedings of the American Society of Civil Engineers, (New York, N. Y., July 1970).
- [6] National Cooperative Highway Research Programs, "Elastomeric Bearing Research," Report No. 199 Highway Research Board (Washington, D. C. 1970).

- [7] Newman, K., and Lachance, L., "The Testing of Brittle Materials Under Uniform Uniaxial Compressive Stress," ASTM Proceedings Vol. 64, American Society for Testing and Materials, (Phila. Pa., 1964).
- [8] ASTM A615-68, Deformed Billet Steel Bars for Concrete Reinforcement, ASTM Standards, Part 4, American Society for Testing and Materials, (Phila, Pa., 1968).

TABLE 4.1.1.1. Joint Materials Used in Evaluating Bearing Capacity of the Columns.

Type	Material Used in Joint	When Used
1	1/4-in thick, 70 durometer (Shore A) neoprene rubber pad, either 10 in x 12 in or 9 1/2 in x 11 1/2 in	Phase I, Test 1, and 2 Phase II, Test 1
2	1-in thick steel plate bonded to the concrete with high strength gypsum plaster.	Phase I, Test 3
3	3/4-in thick non-shrink grout, made of type III portland cement, silica sand and special aggregate. Mix: 1 lb of water to 5 lb of dry ingredients	Phase II, Test 2 and 3
4	Two - 11 ga. (0.12 in) type 304 stainless steel plates (10 in x 12 in) with neoprene pad (Type 1) between the plates	Phase II, Test 4, 5, and 6
5	Same as Type 4 except that the plates were 16 ga. (0.06 in) stainless steel	Phase II, Test 8
6	1/4 in-thick 90 durometer (Shore A) rubber reinforced with many layers of 8 oz cotton duck.	Phase II, Test 7
7	Same as Type 5 with a friction breaker of wax paper between neoprene and plates.	Phase II, Test 9
8	Concrete bearing surface capped to a flat, smooth surface with a thin layer of high-strength gypsum plaster and set on a friction breaker of 2 sheets of 6 mil plastic film placed between the capped surface and a steel bearing block.	Phase II, Test 10

Table 4.1.2 Phase I Test Results on Bearing Capacity of Column Connections

Stub Column Size	Test Number	$f'_c \frac{a}{\text{psi}}$	Type of Joint	Max. Load kip	$\frac{P_u \frac{a}{\text{psi}}}{0.85 f'_c A}$
10 x 12 x 31½ in	1	3660	¼ x 10 x 12 in neoprene	350	0.94
"	2	3660	¼ x 10 x 12 in neoprene	354	0.95
"	3	3660	Single stub set in plaster on 1 in thick plate	585	1.56

^{a/} Symbols: f'_c = Concrete cylinder (6"x 12") strength at time of test.
 P_u = Maximum load
 A = Bearing area= 120 sq. in.

Table 4.1.3 Phase II Test Results on Bearing Capacity of Column Connections

Column Stub Size	Test Number	f'_c ^{a/} psi	Type of Joint	Max. Load Kip	$\frac{P_u}{0.85 A}$ ^{a/}
10 x 12 x 51½ in	1	4340	½ x 10 x 12 in neoprene	477	1.08
"	2	4160	¾ thick grout ^{b/}	535	1.26
"	3	4510	¾ thick grout ^{c/}	519	1.12
"	4	4155	2-St.St. plates and ½ x 10 x 12 in neoprene	580	1.37
"	5	4342	2-St.St. plates and ½ x 9 x 11 in neoprene	586	1.32
"	6 ^{e/}	4881	2-St.St. plates and ½ x 9 x 11 in neoprene	420 ^{e/}	1.26 ^{e/}
"	7	4590	½ x 10 x 12 in reinforced rubber	493 ^{f/}	1.05
"	8	4881	2-St.St. plates, and ½ x 9 x 11 in neoprene	556	1.11
"	9	4881	2-St.St. plates, wax paper and ½ x 9 x 11 in neoprene	598	1.20
"	10	4881	1 stub set in plaster + 2 sheets of plastic film between plaster and steel bearing plate.	600 ^{g/}	1.20

^{a/} Symbols: f'_c = Concrete cylinder strength at time of test.
 P_u = Maximum load
 A = Bearing area = 120 in²

^{b/} Grout compressive strength (2 in. cube) at time of test = 5210 psi

^{c/} " " " " " " " 6200 psi

^{d/} Smaller size (9 x 11 in) neoprene pad filled bearing area at failure, Smaller size was selected to prevent unsightly extrusion from joint.

^{e/} Loaded with 2-in. major-axis eccentricity at the joint. Bearing area, A , was computed using the Whitney stress block concept.

^{f/} Rubber pad ruptured before maximum load was reached.

^{g/} Held 600 kips for 5 min. before failure initiated.

Table 4.1.4 Measured Compressive Deformations of Phase II^{a/}
 Rubber Pad Joints at Various Compressive Loads

Test Number	Type of Joint	Deformation at Stated Load				
		100 Kip in	200 Kip in	300 Kip in	400 Kip in	500 Kip in
1	Neoprene	.034	.037	.041	----	----
4	11 ga. plate and neoprene	.034	.042	.049	.057	.068
5	"	.029	.036	.041	.049	.062
7	Reinf. rubber	.026	.033	.041	.045	----
8	16 ga. plate and neoprene	.022	.038	.062	.088	.118
9	16 ga. plate, wax paper & neoprene	.014 ^{b/}	.024	.046	.068	.086
Test Results Section 4.3	Neoprene and steel	.027	.040	.052	.060	

^{a/} All specimens were preloaded to about 200 kip prior to test run. Deformations do not include "permanent set" from preload.

^{b/} During preloading to 200 kip pad was compressed approximately 0.10 in. Recovered only to 0.09 in. Initial compression was significantly lower and recovery greater for others.



FIGURE 2.1 PROPOSED BUILDING



FIGURE 2.2 BUILDING COMPLEX UNDER CONSTRUCTION

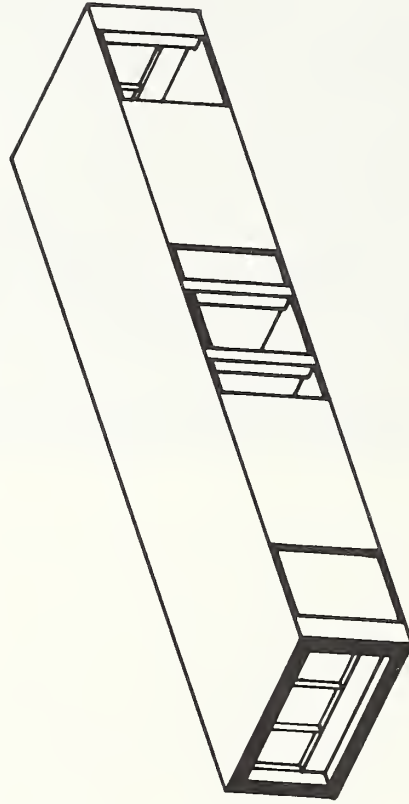

FIGURE 2.3 PROPOSED MODULAR UNIT

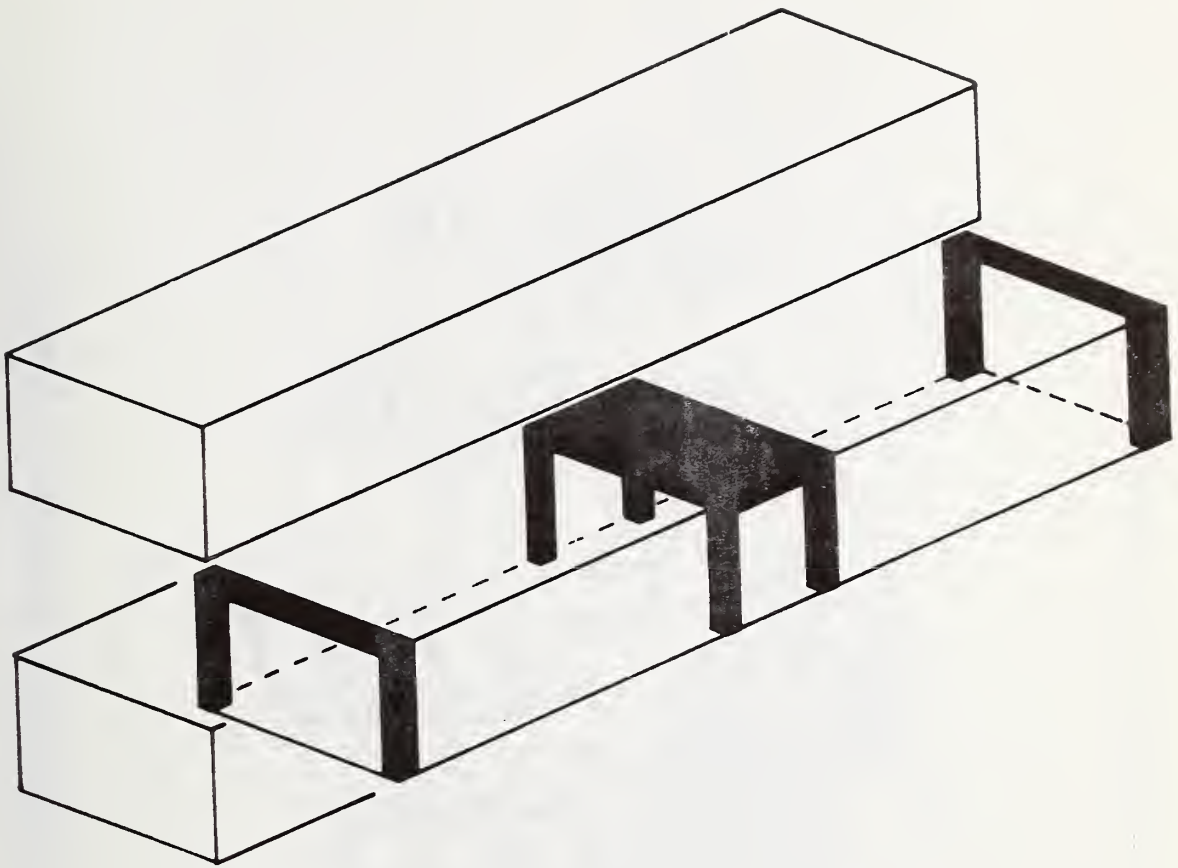

FIGURE 2.4 STRUCTURAL SKELETON OF MODULE

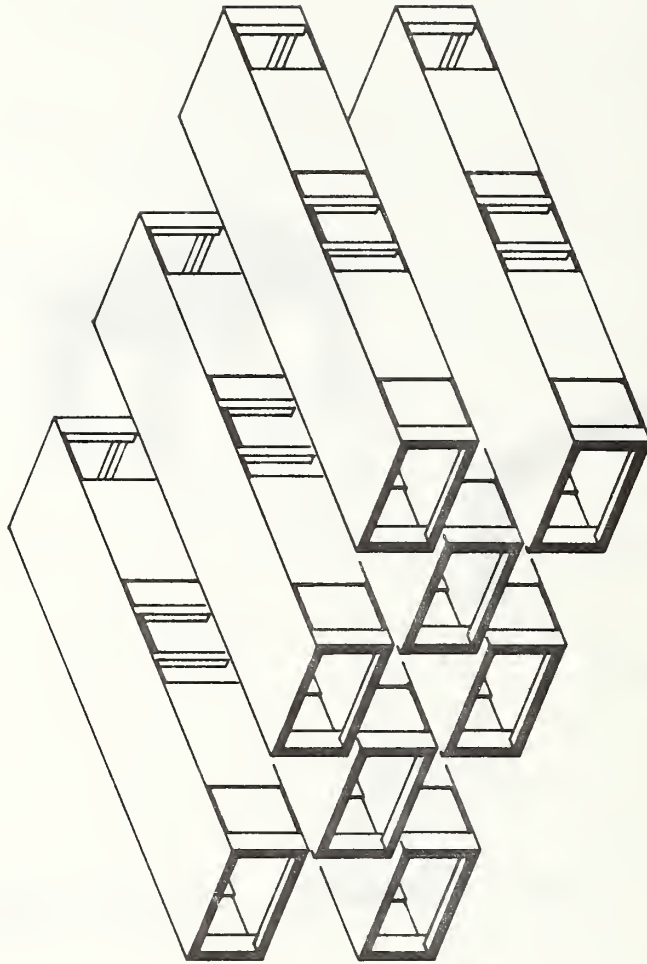

FIGURE 2.5 CHECKERBOARD ARRANGEMENT OF MODULES

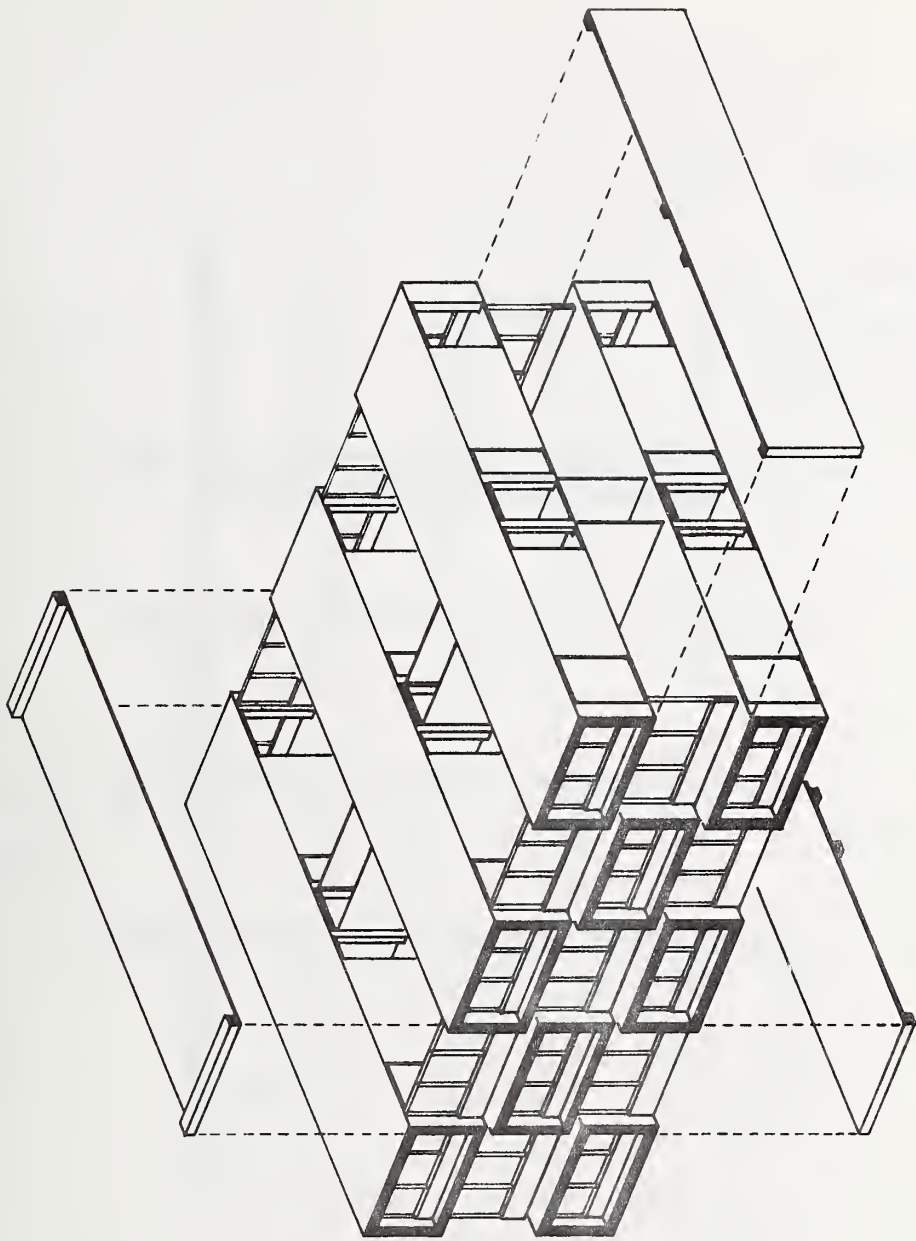

FIGURE 2.6 COMPLETION OF STRUCTURAL ASSEMBLY

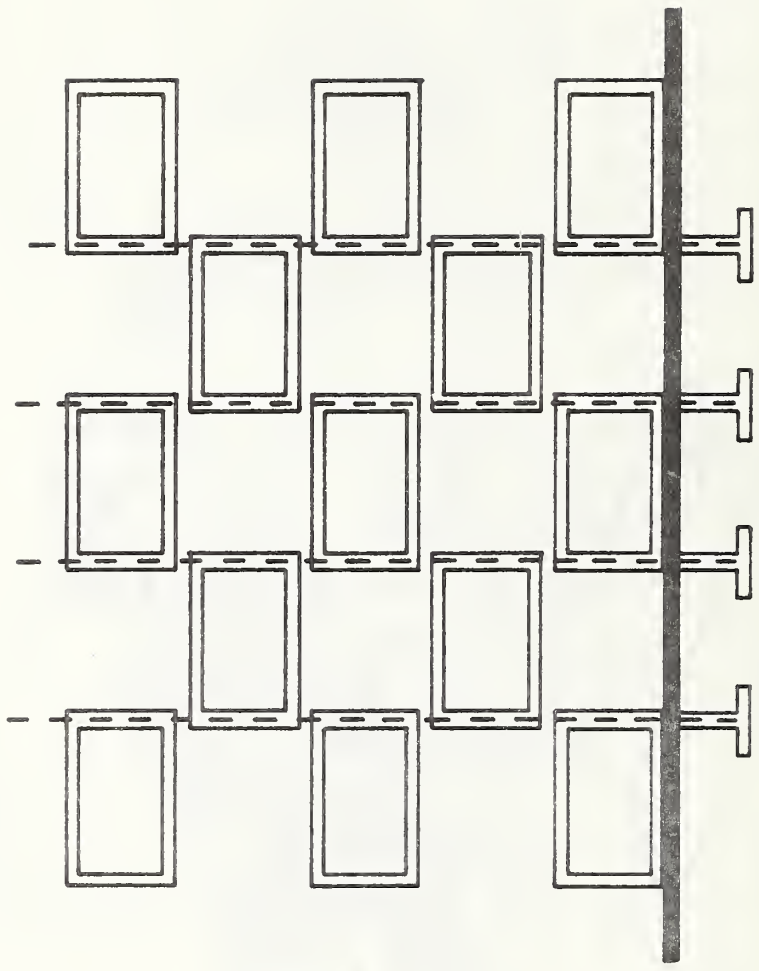

FIGURE 2.7 SCHEMATIC DRAWING OF CONNECTION TIEDOWN

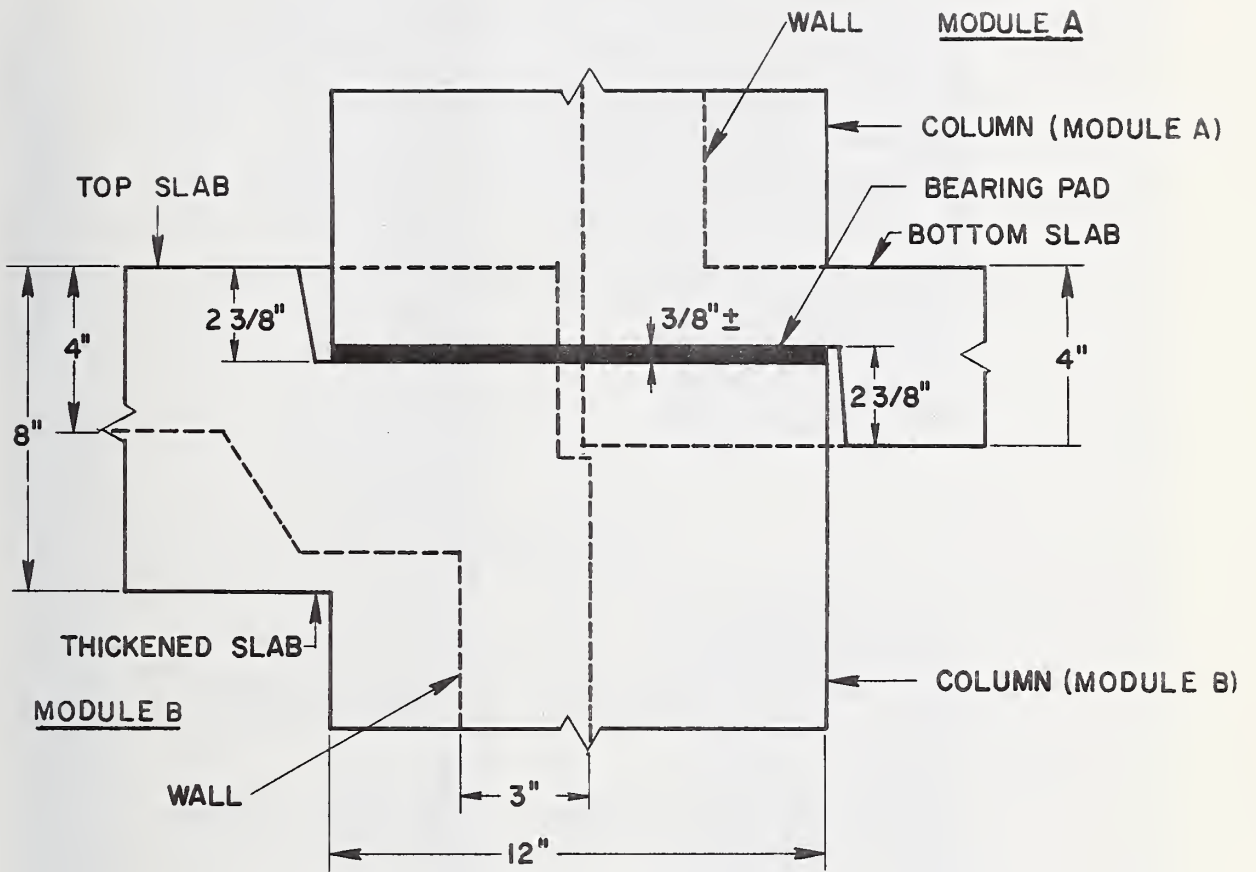
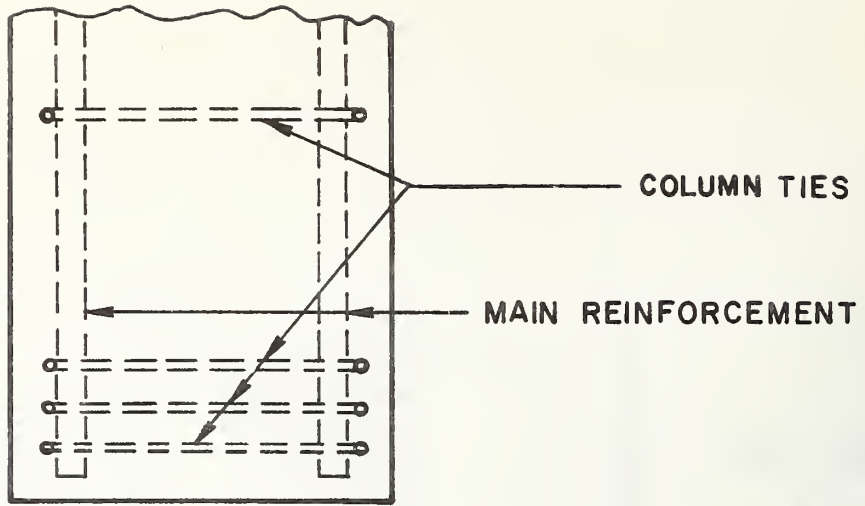
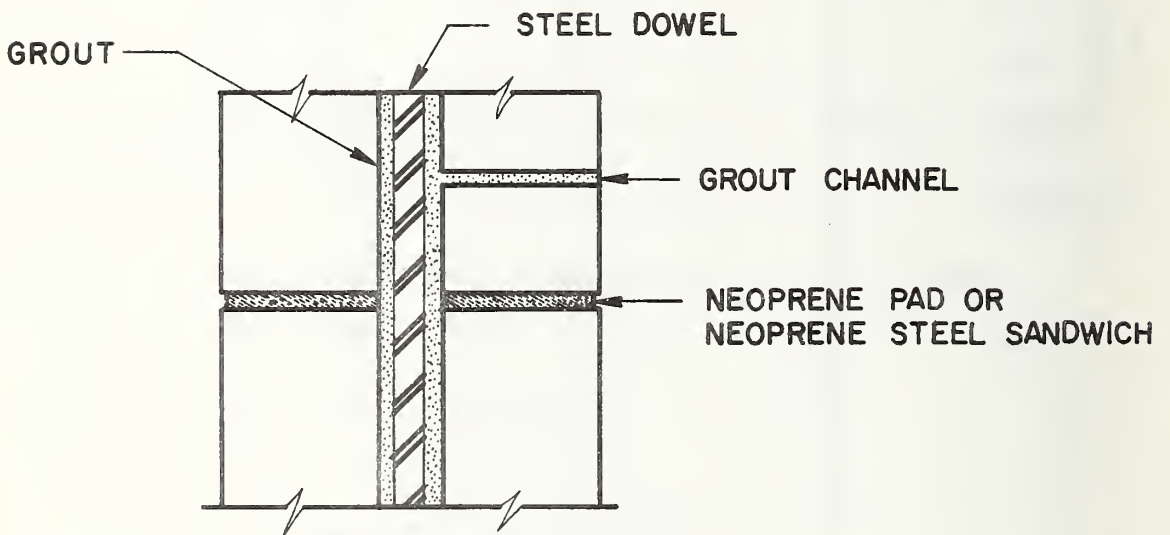

FIGURE 2.8 DETAIL OF INTERIOR COLUMN JOINT



(a) COLUMN REINFORCEMENT AT CONNECTION



(b) CONNECTION DETAIL

FIGURE 2.9 PROPOSED CONNECTION DETAIL

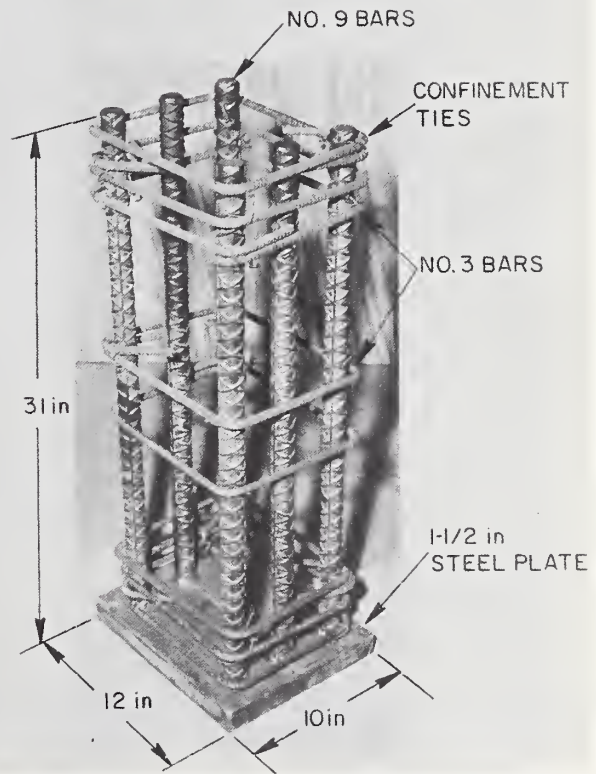
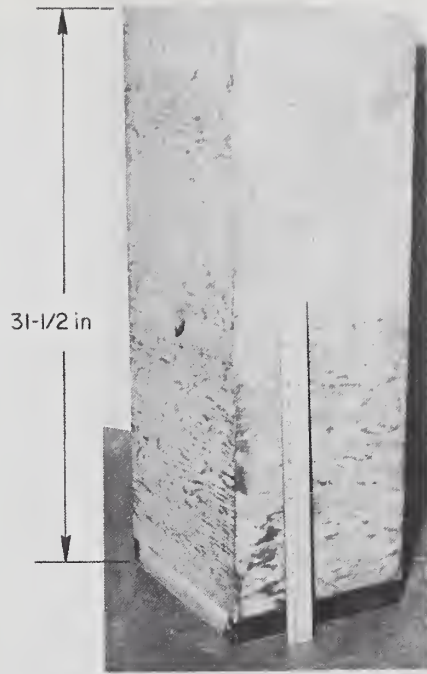
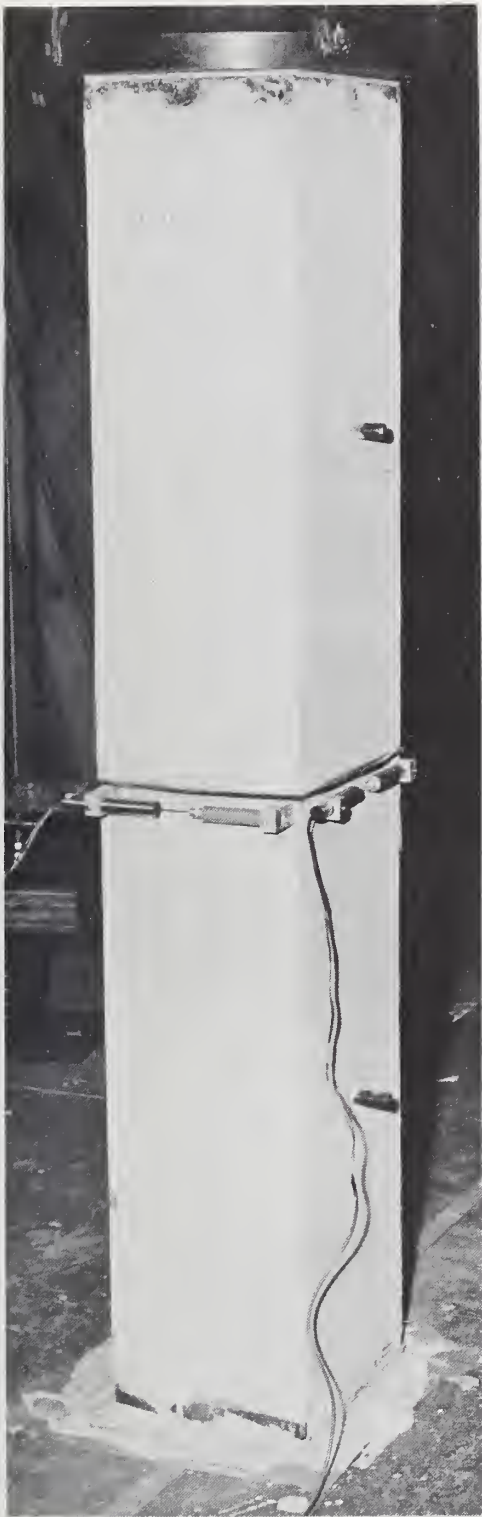

FIGURE 4.1 SPECIMEN USED IN PHASE I COLUMN CONNECTION TESTS

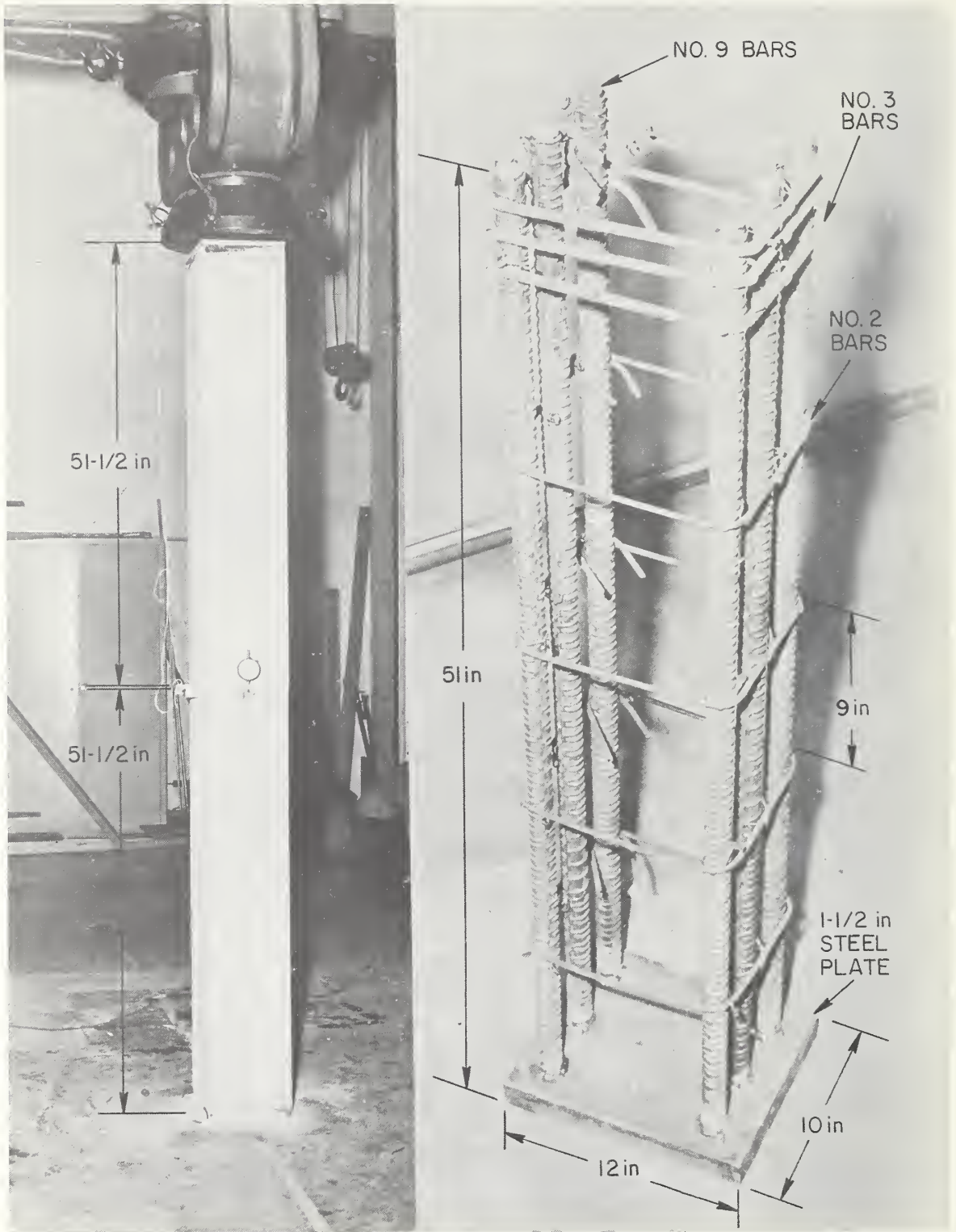

FIGURE 4.2 SPECIMEN USED IN PHASE II COLUMN CONNECTION TESTS

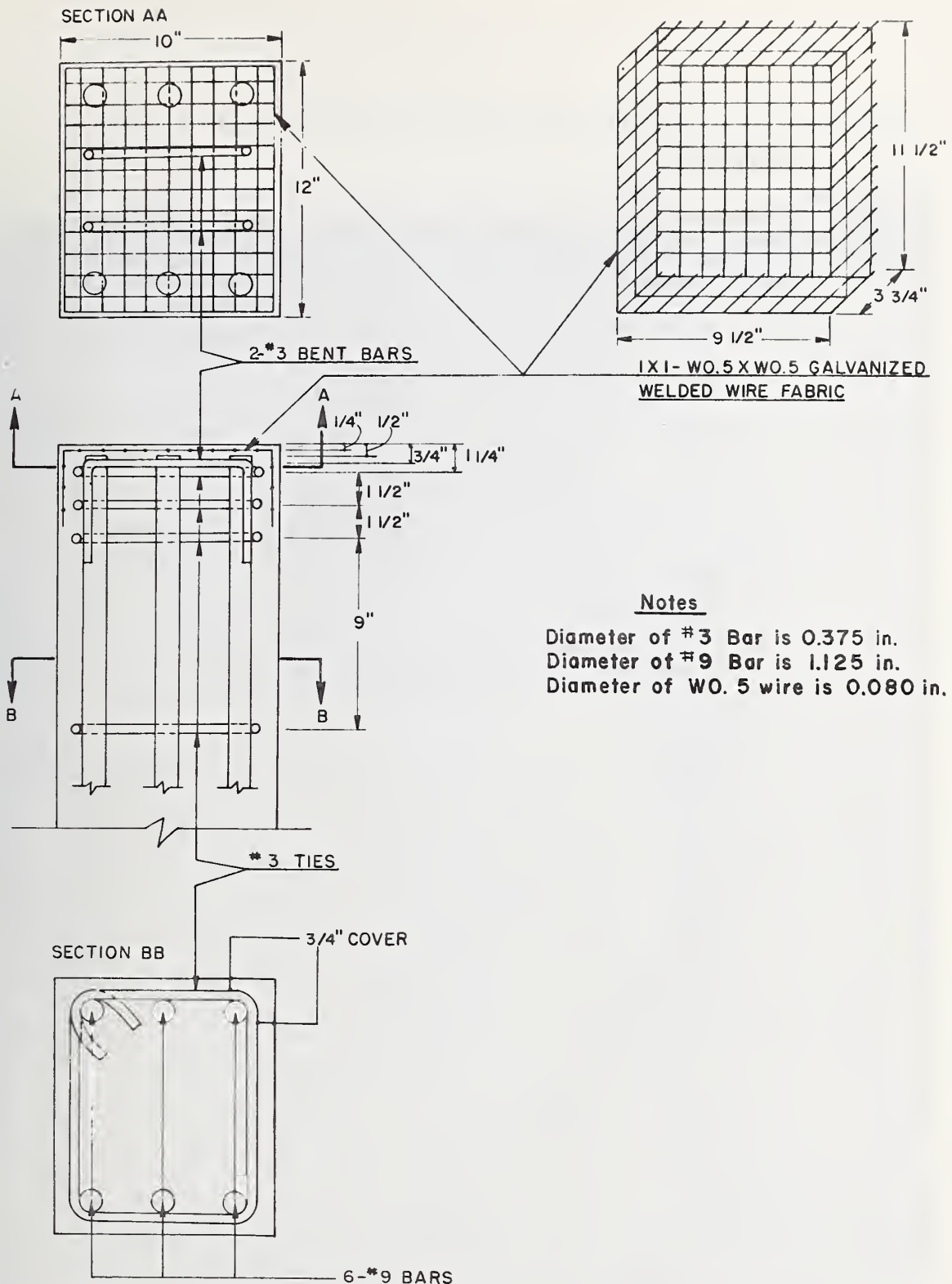

FIGURE 4.3 TYPICAL DETAILS OF TEST SPECIMENS

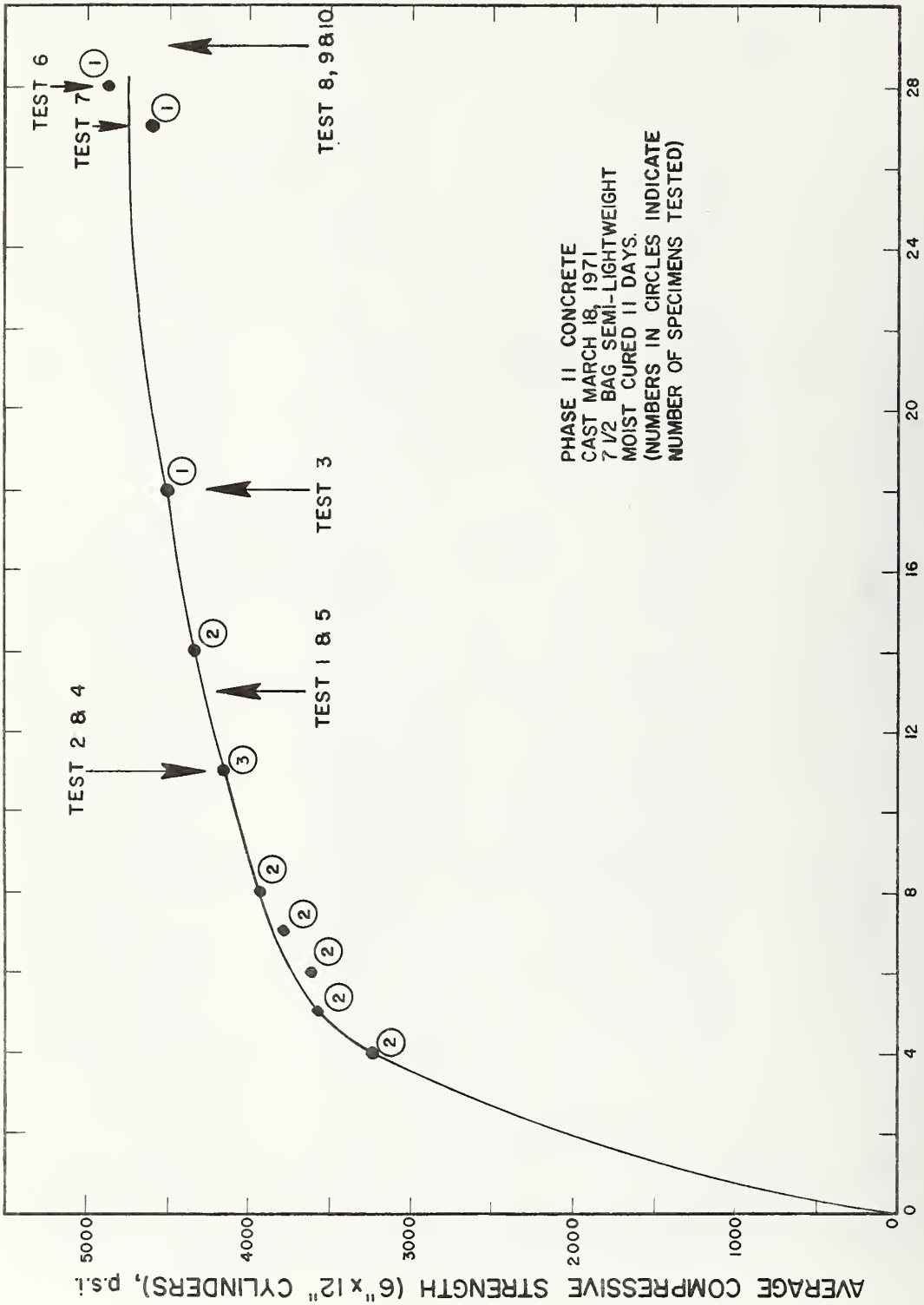

FIGURE 4.4 STRENGTH TO AGE RELATIONSHIP OF CONCRETE USED FOR COLUMN STUBS



FIGURE 4.5 TYPICAL FAILURE OF CONNECTION USING 1/4-IN NEOPRENE PAD

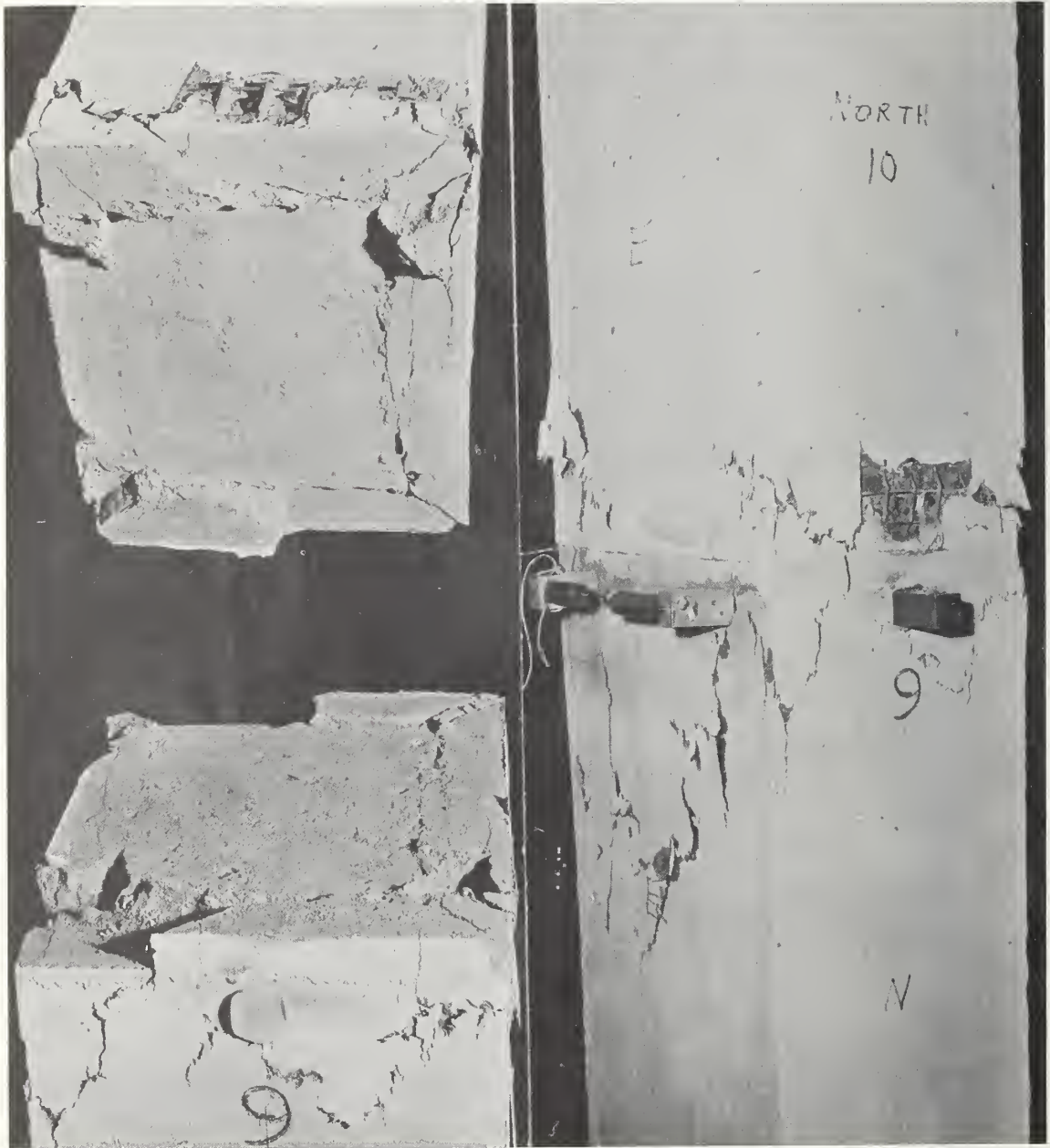

FIGURE 4.6 TYPICAL FAILURE OF A GROUTED CONNECTION

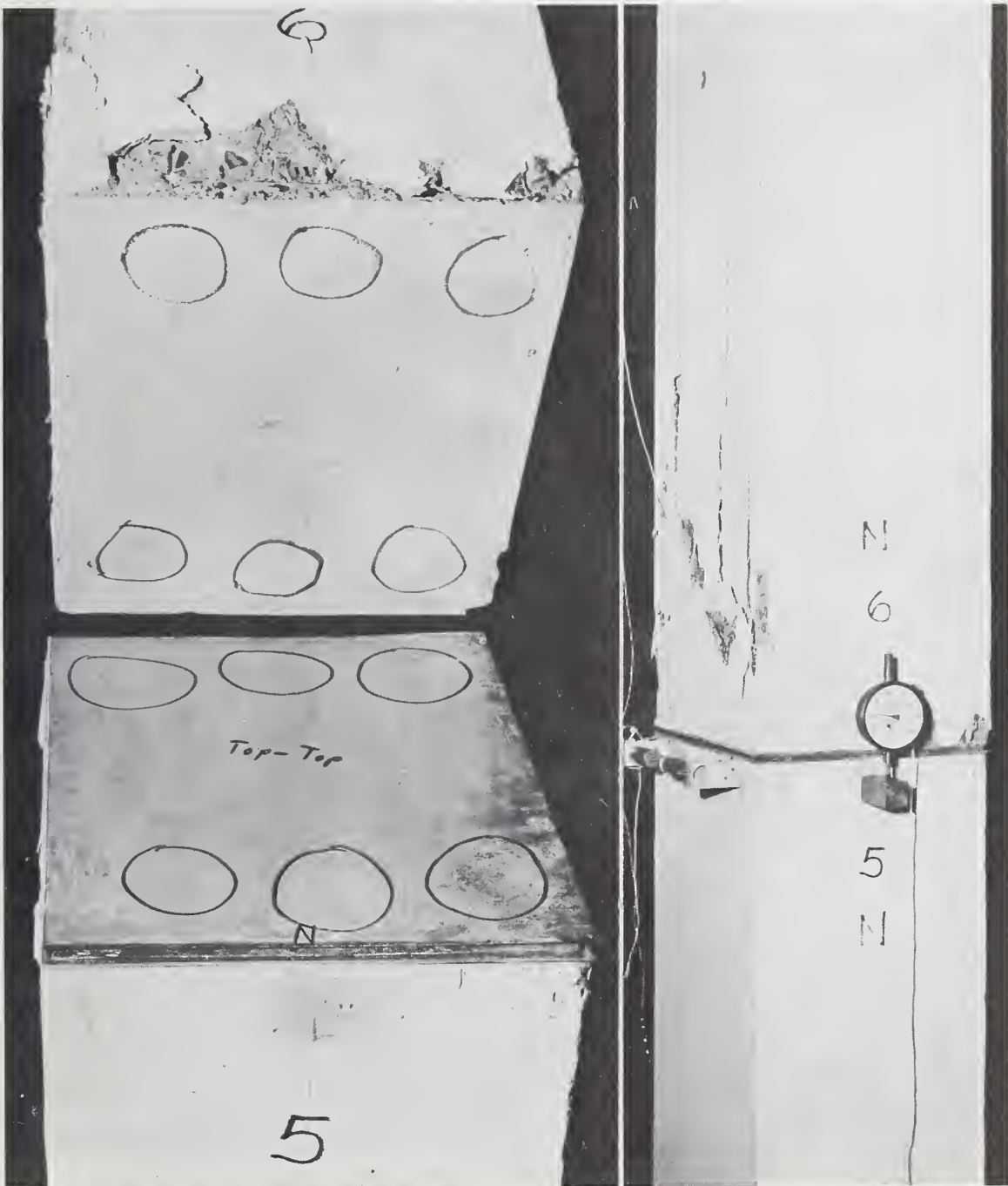

FIGURE 4.7 TYPICAL FAILURE OF CONNECTION USING A STEEL-NEOPRENE-STEEL SANDWICH

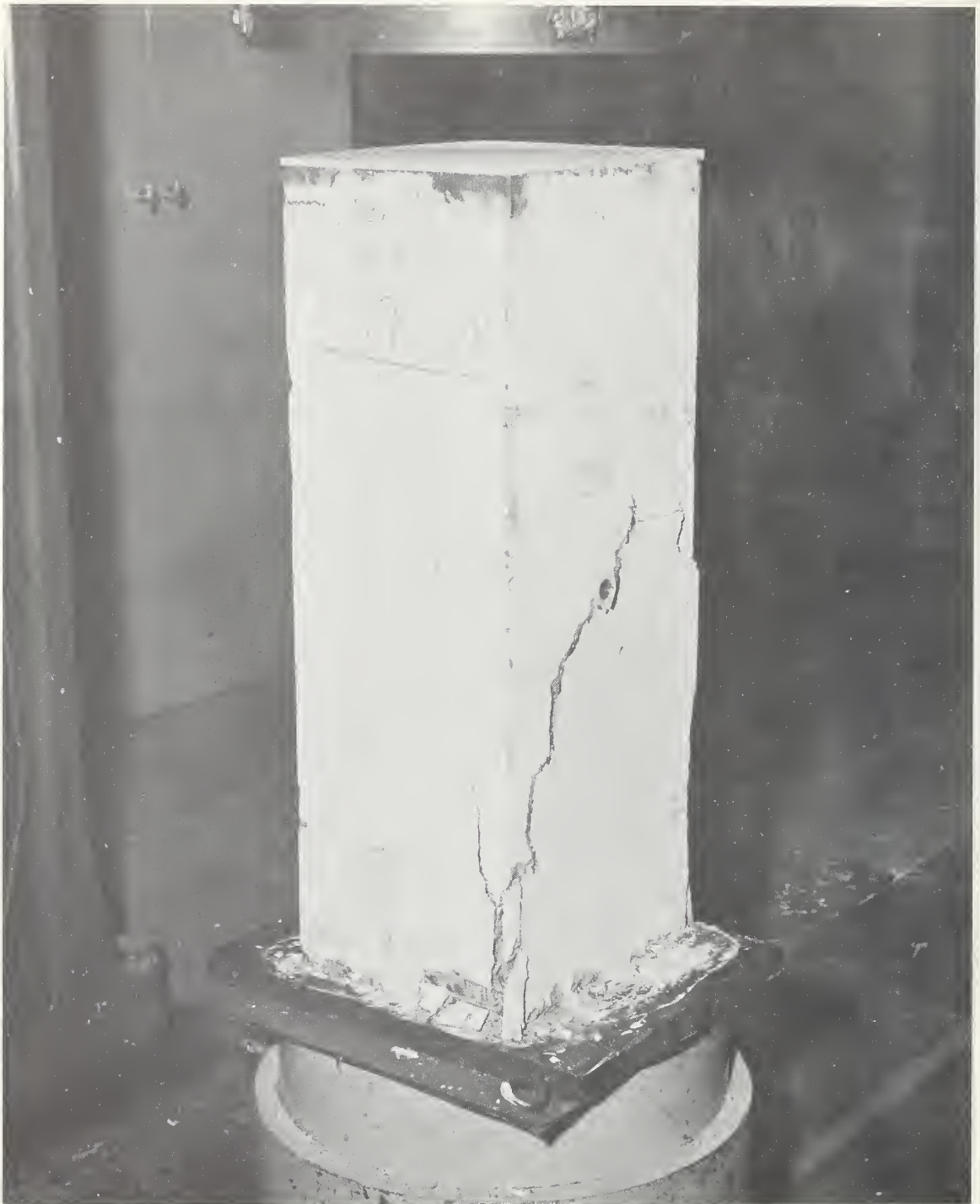

FIGURE 4.8 FAILURE OF COLUMN STUB BEARING ON A STEEL PLATE AND BEDDED IN HIGH STRENGTH GYPSUM

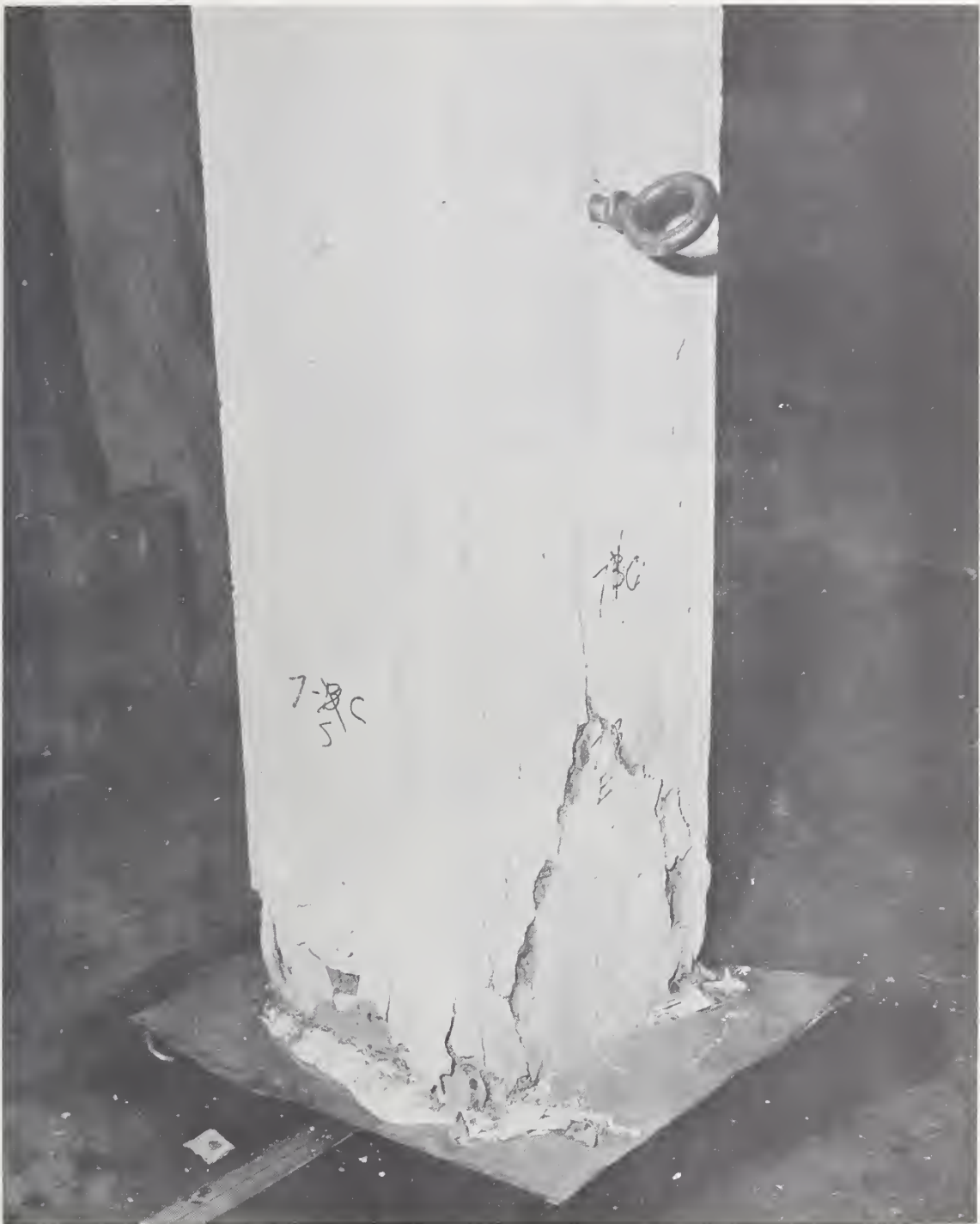
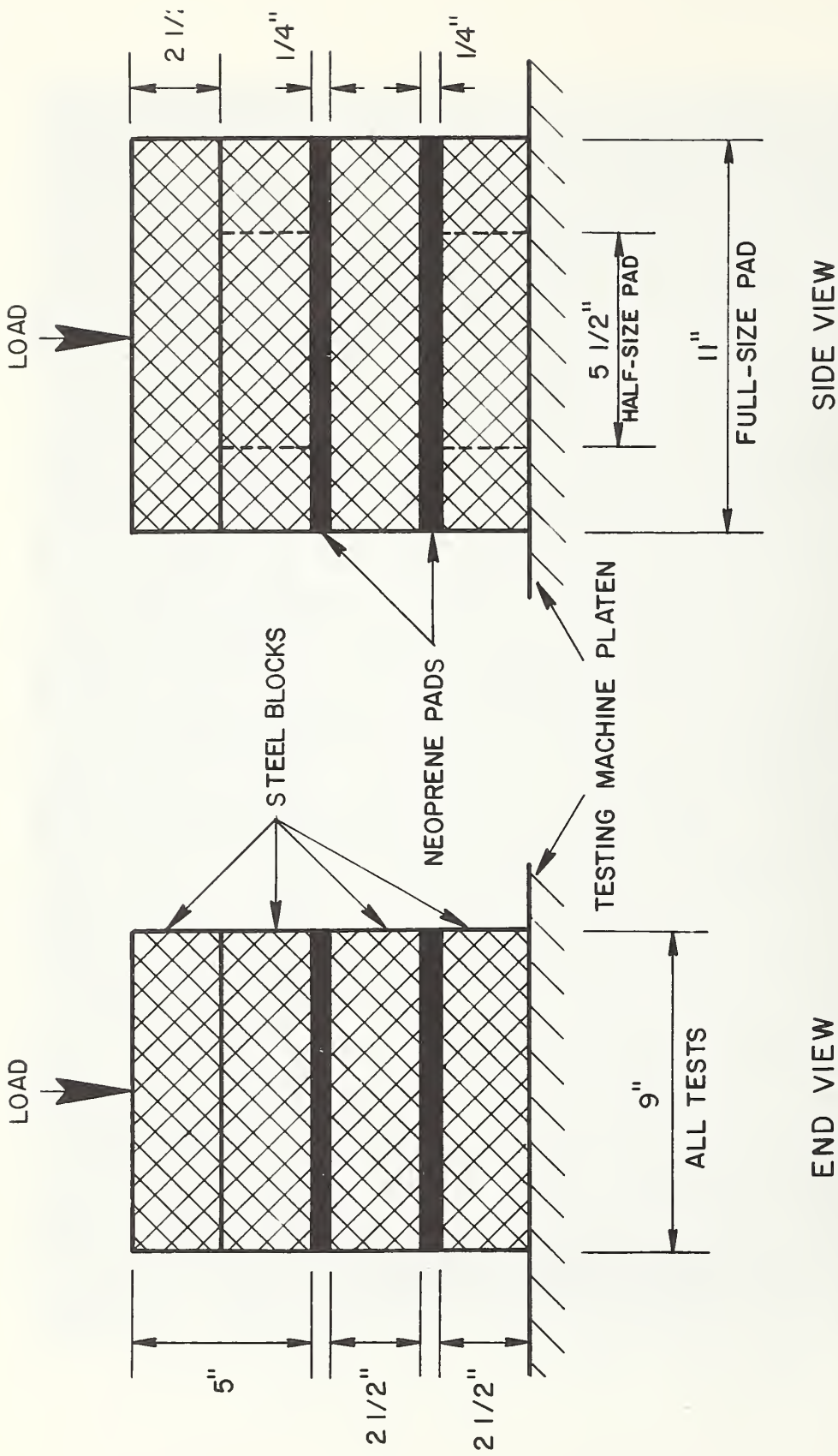

FIGURE 4.9 FAILURE OF COLUMN STUB BEARING ON A STEEL PLATE COVERED BY A LOW FRICTION MEMBRANE.



END VIEW

SIDE VIEW

FIGURE 4.10 TEST ARRANGEMENT TO DETERMINE LOAD-DEFORMATION CHARACTERISTICS FOR THE NEOPRENE PADS

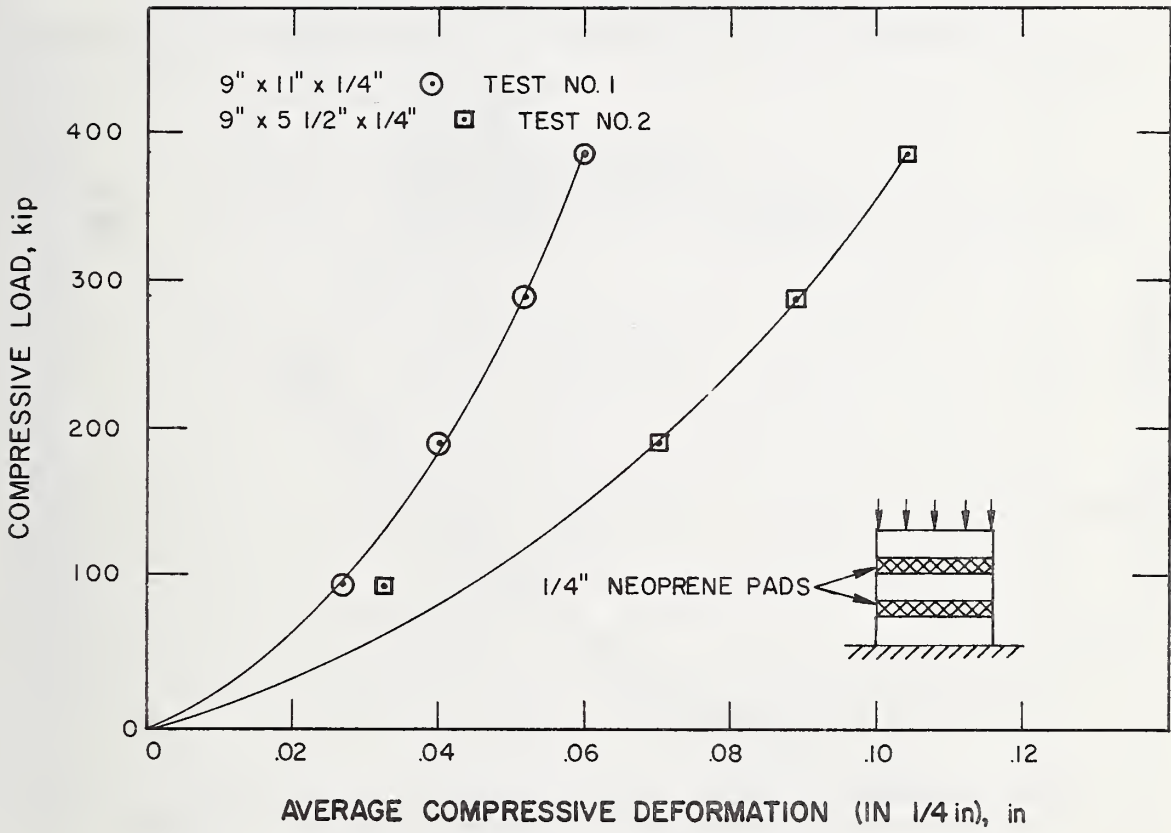

FIGURE 4.11 RELATIONSHIP BETWEEN COMPRESSIVE LOAD AND AVERAGE COMPRESSIVE DEFORMATION OF NEOPRENE PADS

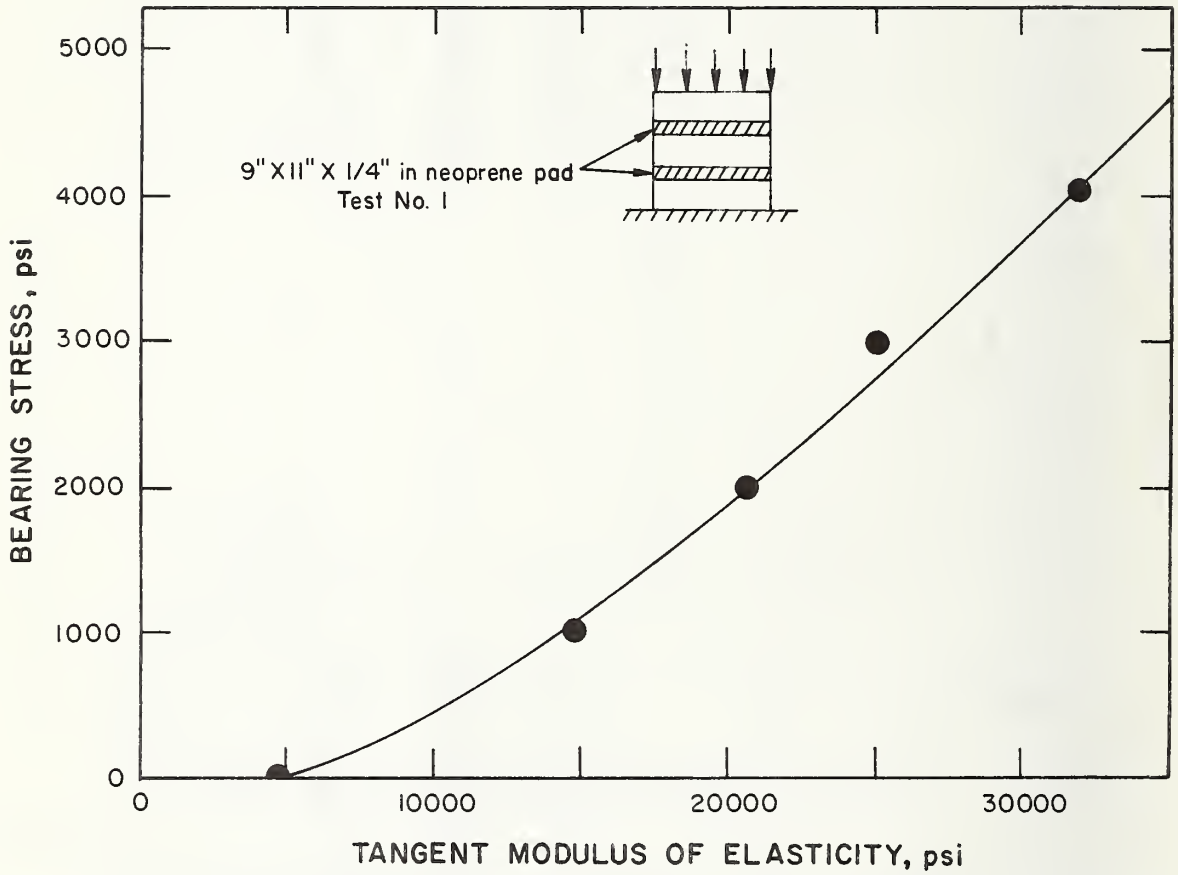

FIGURE 4.12 RELATIONSHIP BETWEEN COMPRESSIVE STRESS AND TANGENT MODULUS OF ELASTICITY FOR THE FULL-SIZED NEOPRENE PADS

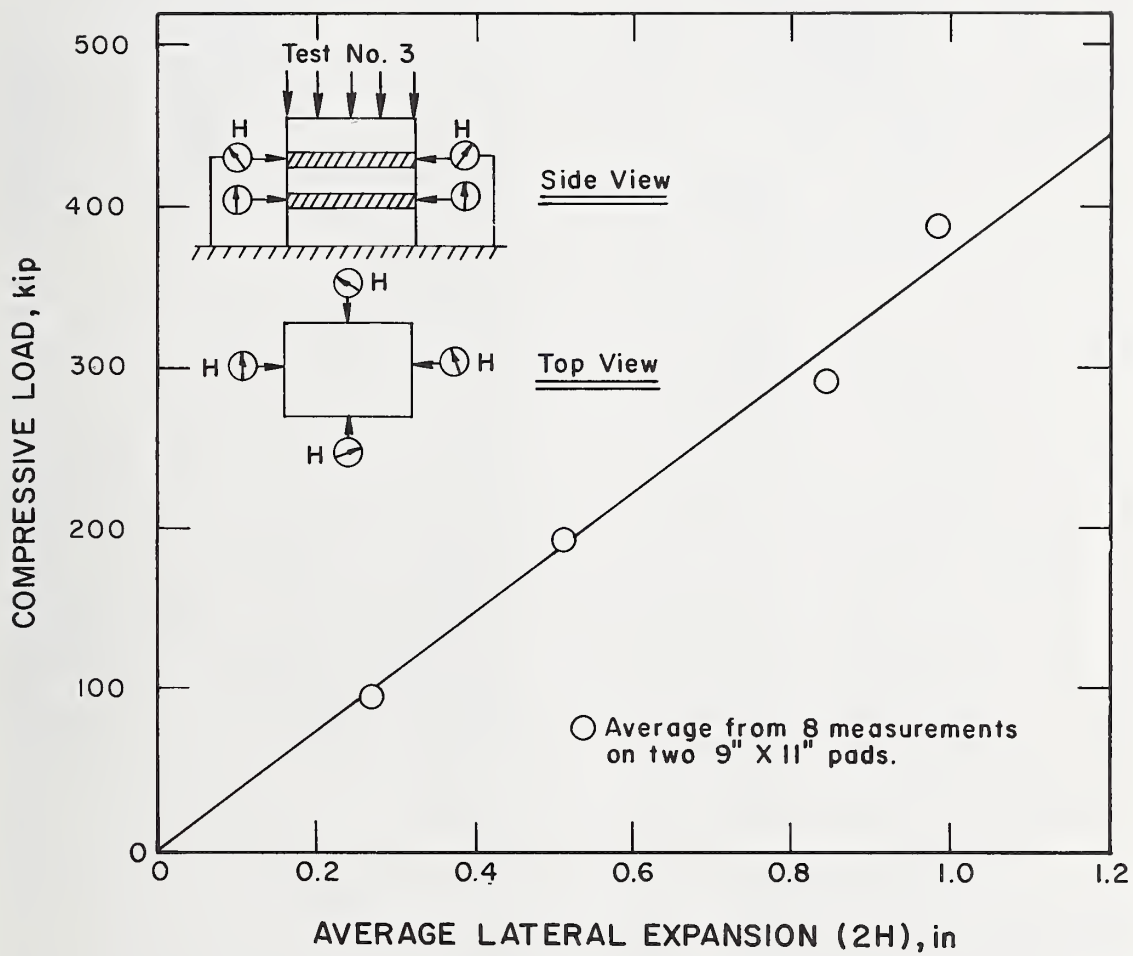

FIGURE 4.13 RELATIONSHIP BETWEEN COMPRESSIVE LOAD AND MAXIMUM EXTRUSION FOR THE FULL-SIZED NEOPRENE PADS

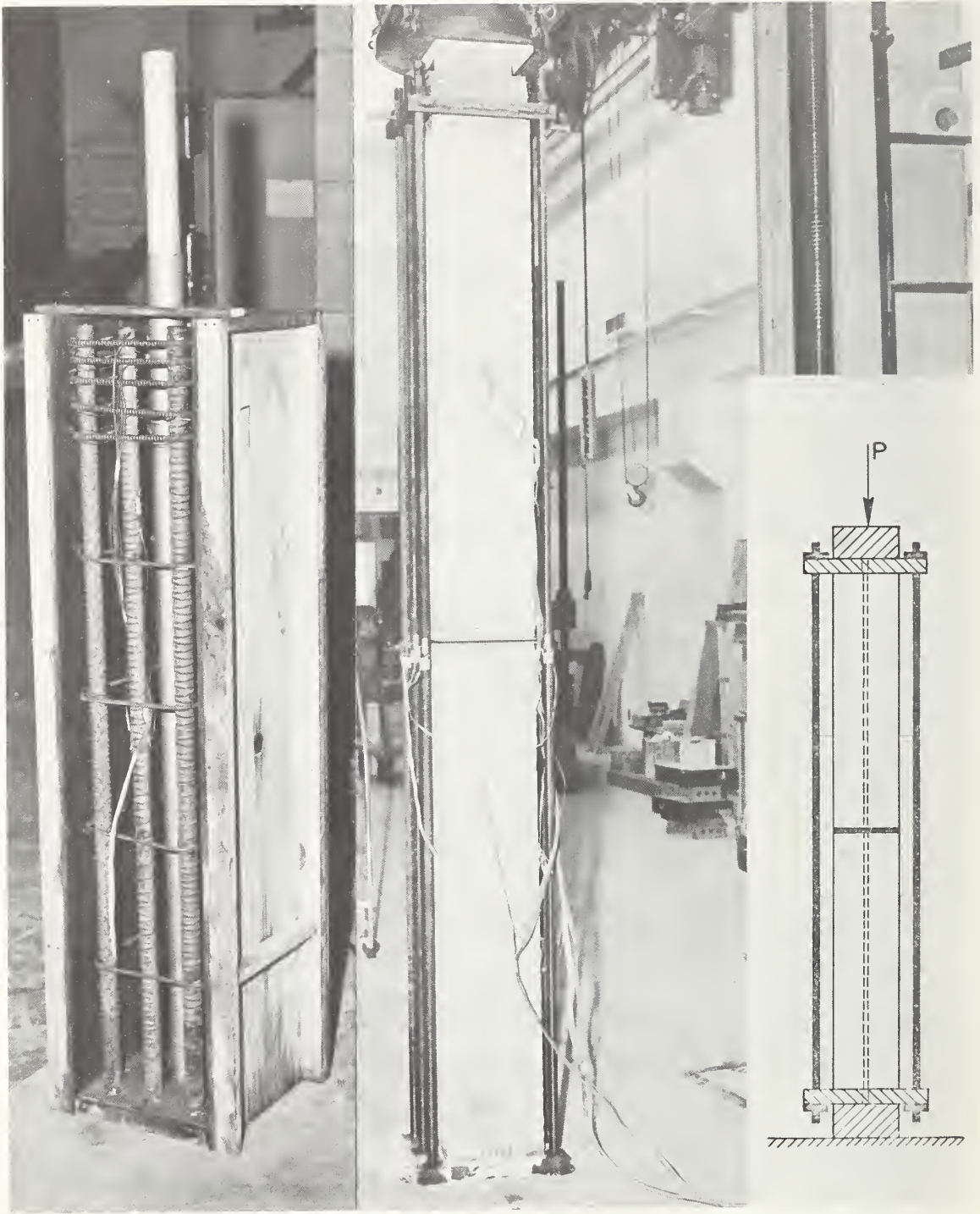
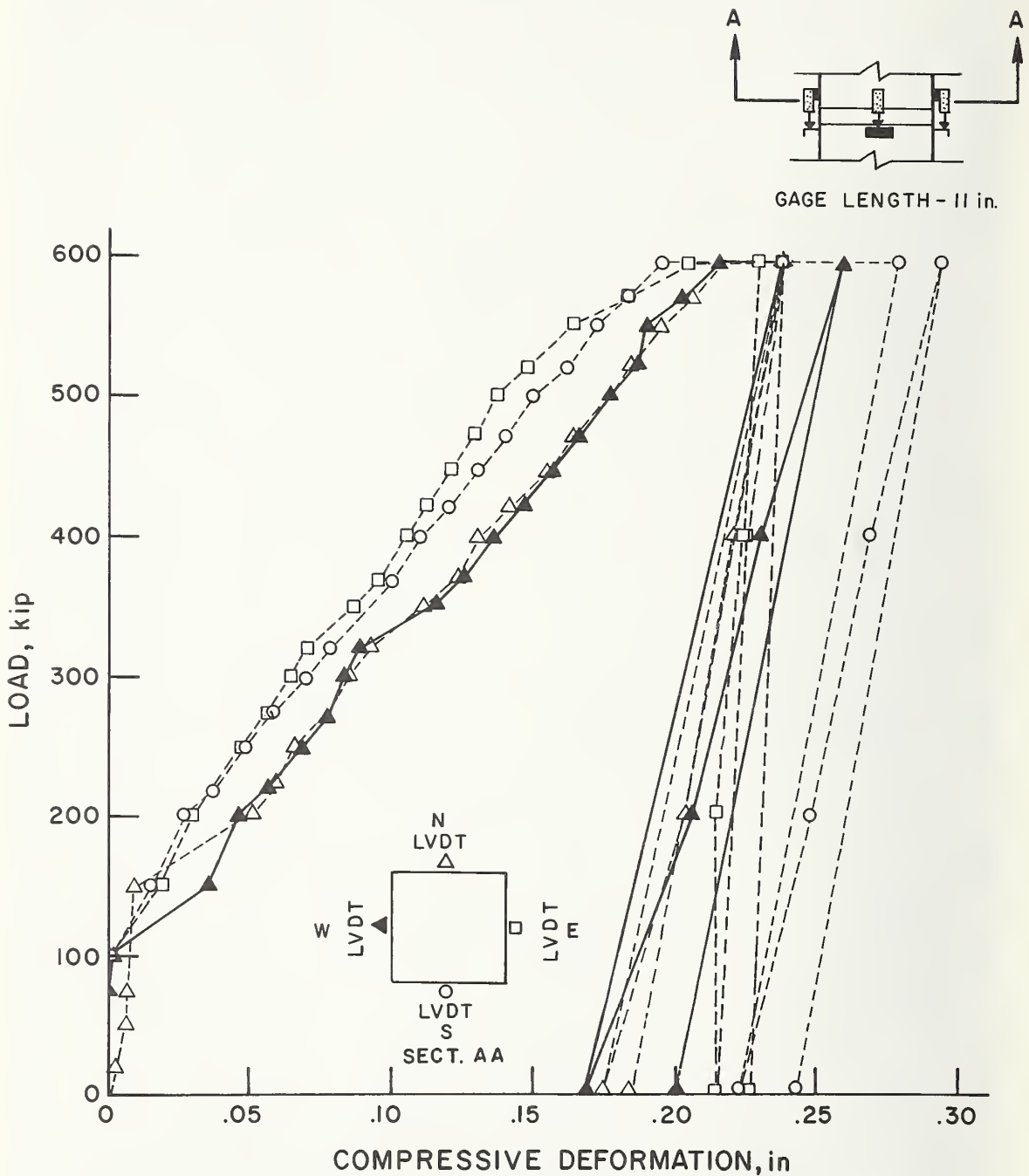

FIGURE 4.14 TEST ON SPECIMEN WITH GROUTED DOWEL



FIGURE 4.15 INSTRUMENTATION OF TEST SPECIMEN WITH GROUTED DOWEL



4.16 SPECIMEN WITH GROUTED DOWEL VERTICAL DEFORMATIONS OF AN 11-IN SEGMENT INCLUDING THE JOINT

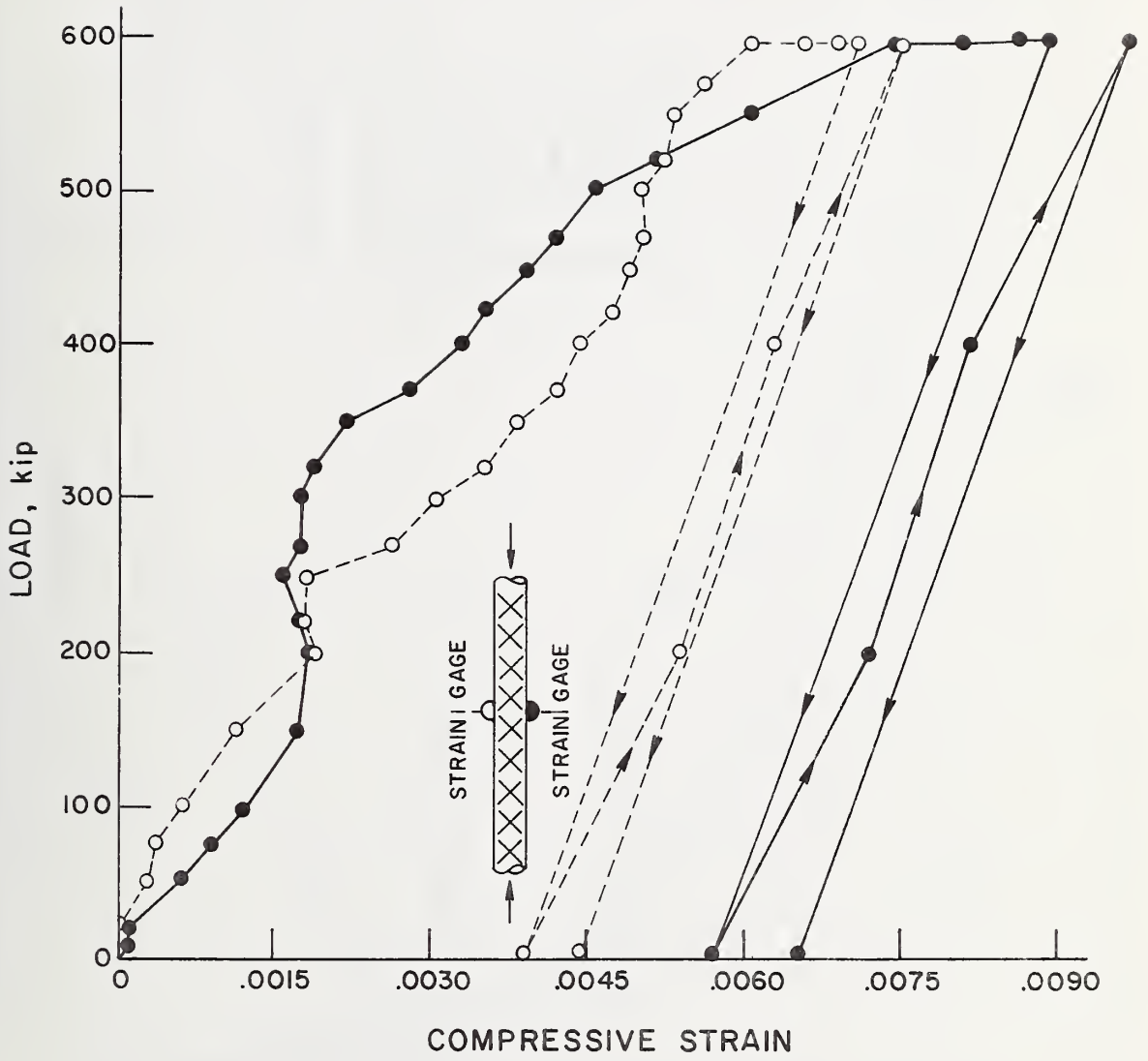

4.17 SPECIMEN WITH GROUTED DOWEL, LONGITUDINAL DOWEL STRAIN IN THE JOINT

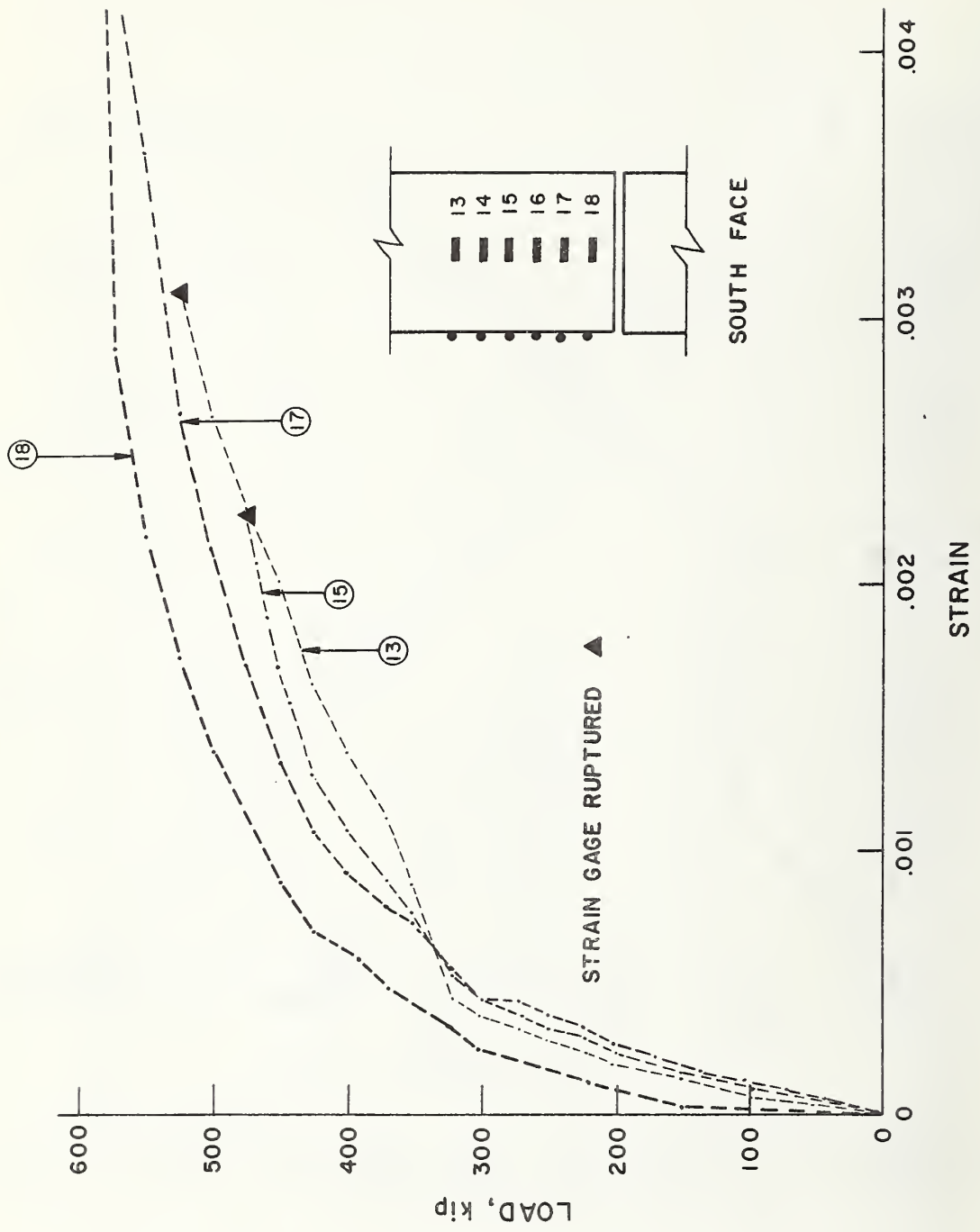

4.18 SPECIMEN WITH GROUTED DOWEL, HORIZONTAL STRAIN OF CONCRETE ON SOUTH COLUMN FACE.

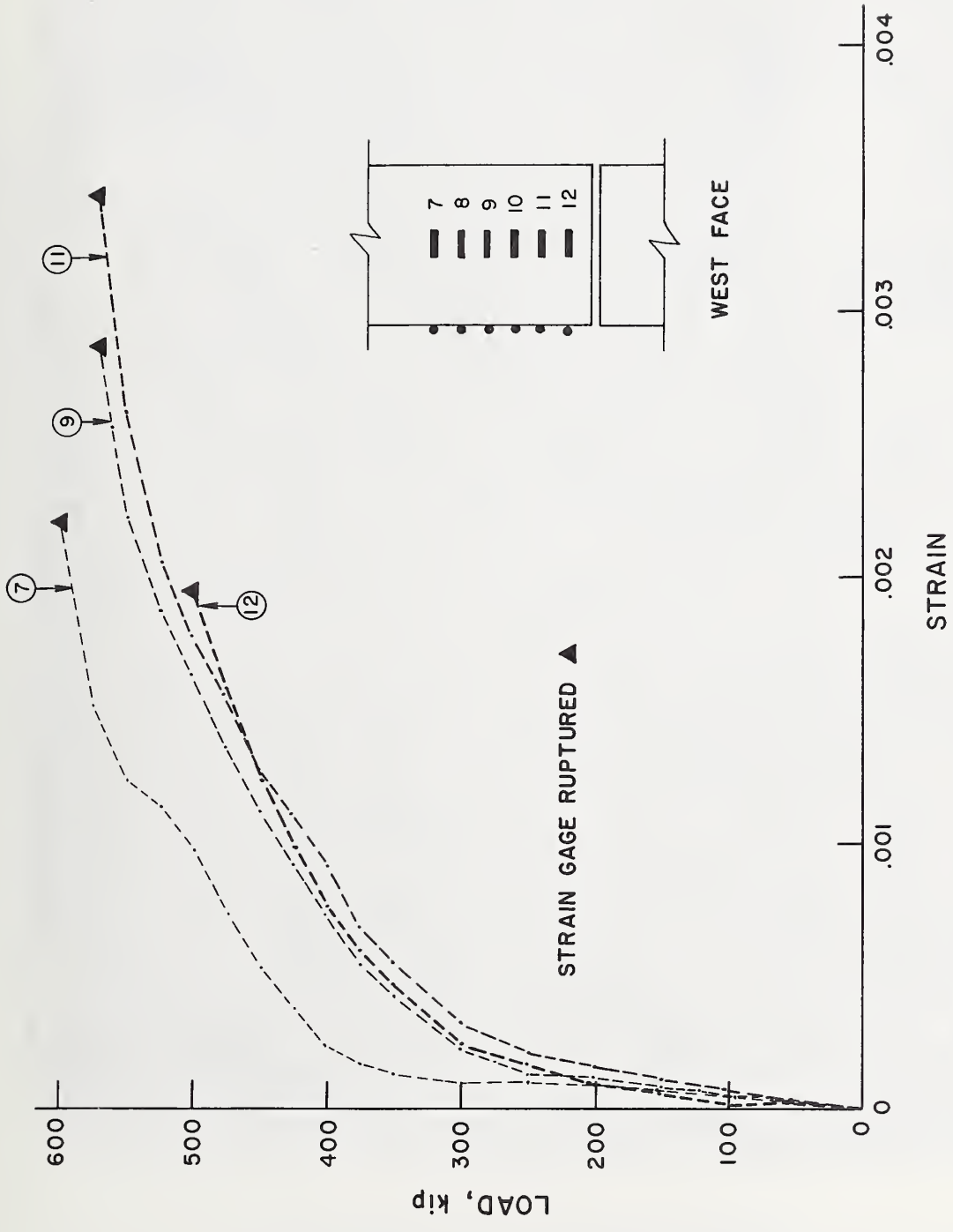

4.19 SPECIMEN WITH GROUTED DOWEL, HORIZONTAL STRAIN OF CONCRETE ON WEST COLUMN FACE.



FIGURE 4.20 DETAILS OF SHEAR TEST SPECIMENS

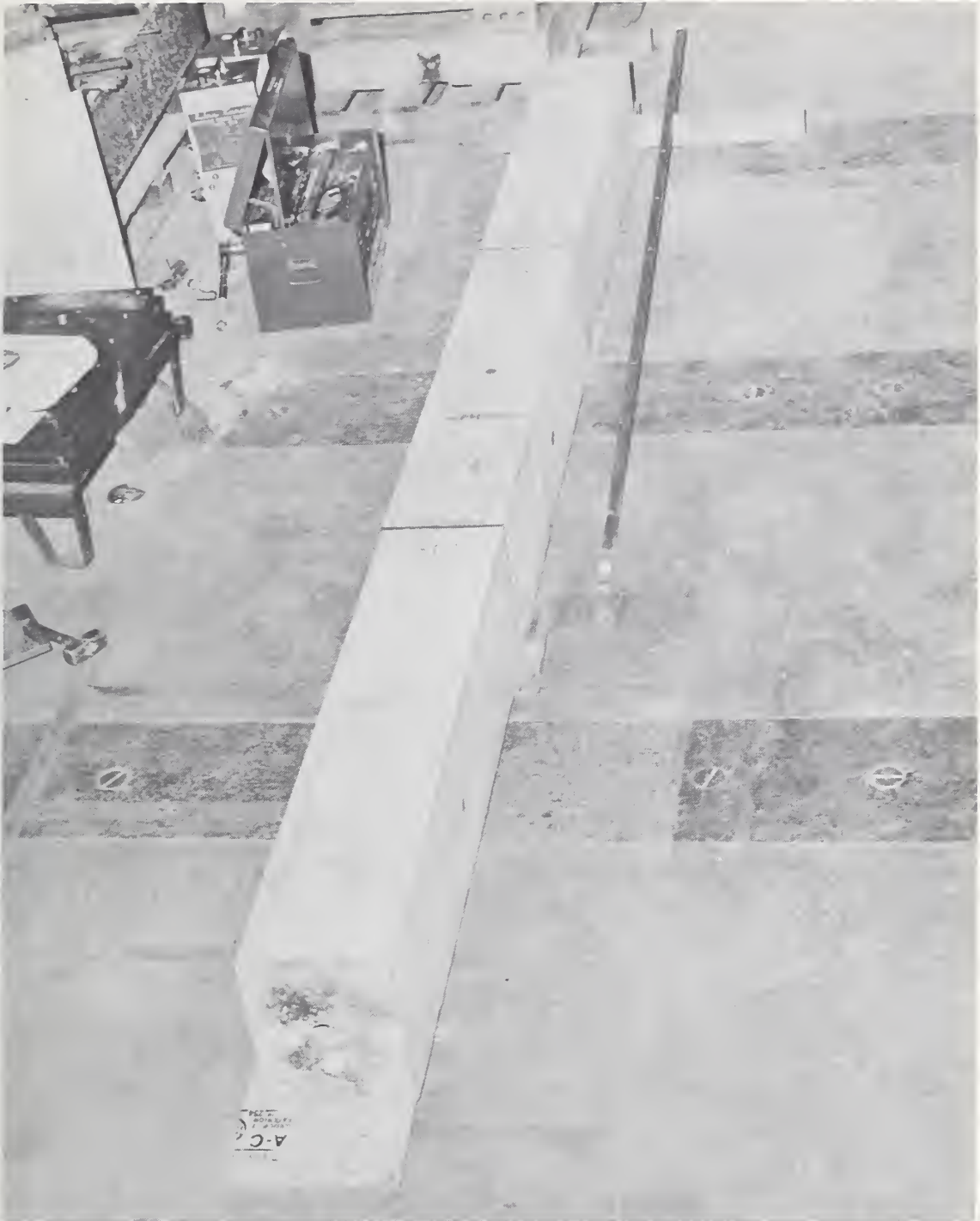

FIGURE 4.21 SPECIMEN ARRANGED FOR PRE-LOADING AND GROUTING OF THE DOWEL

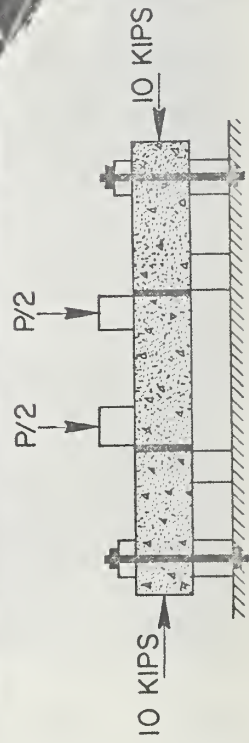
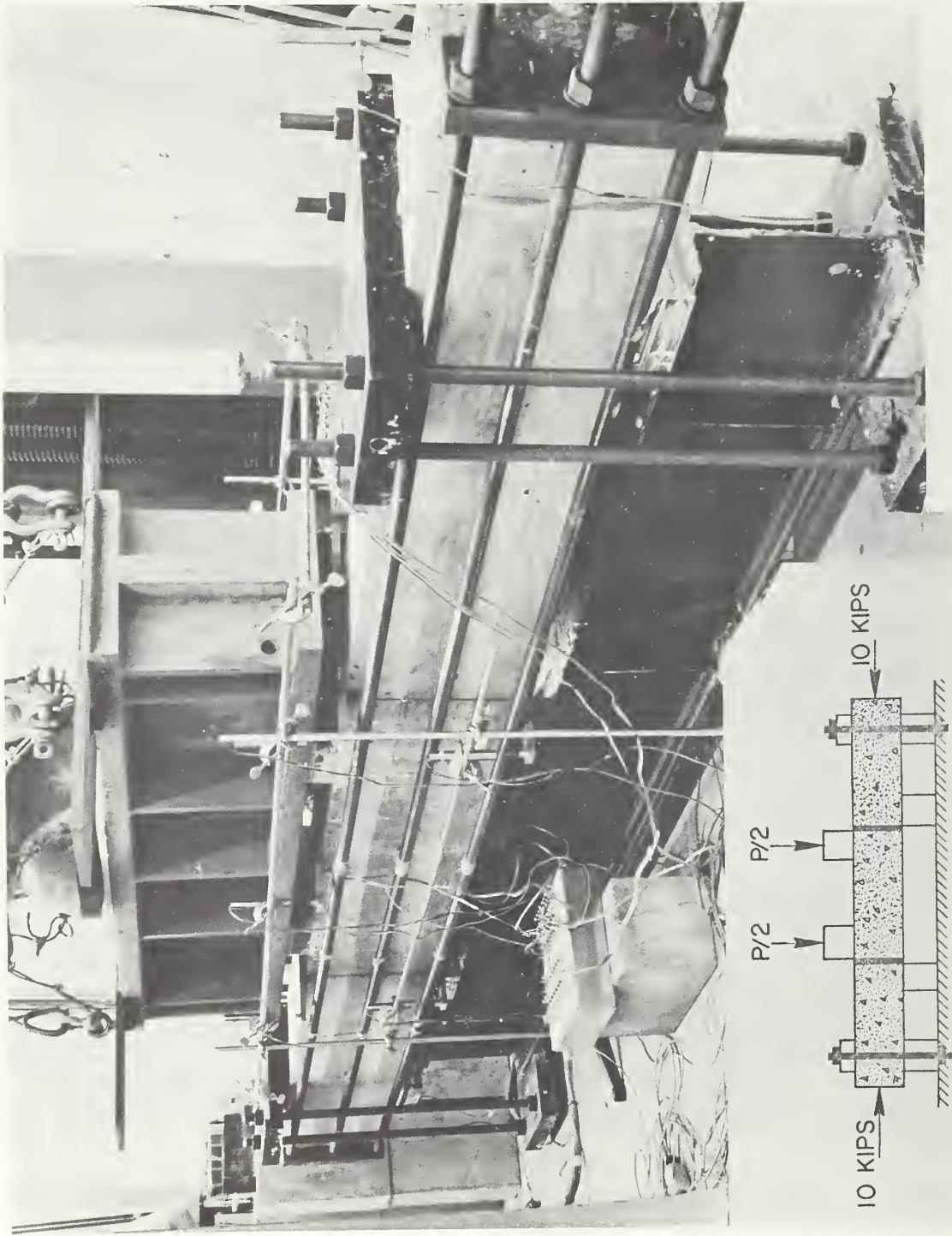

FIGURE 4.22 ARRANGEMENT FOR SHEAR TEST 1

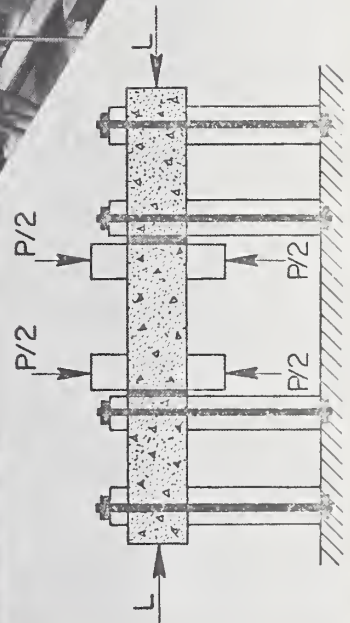
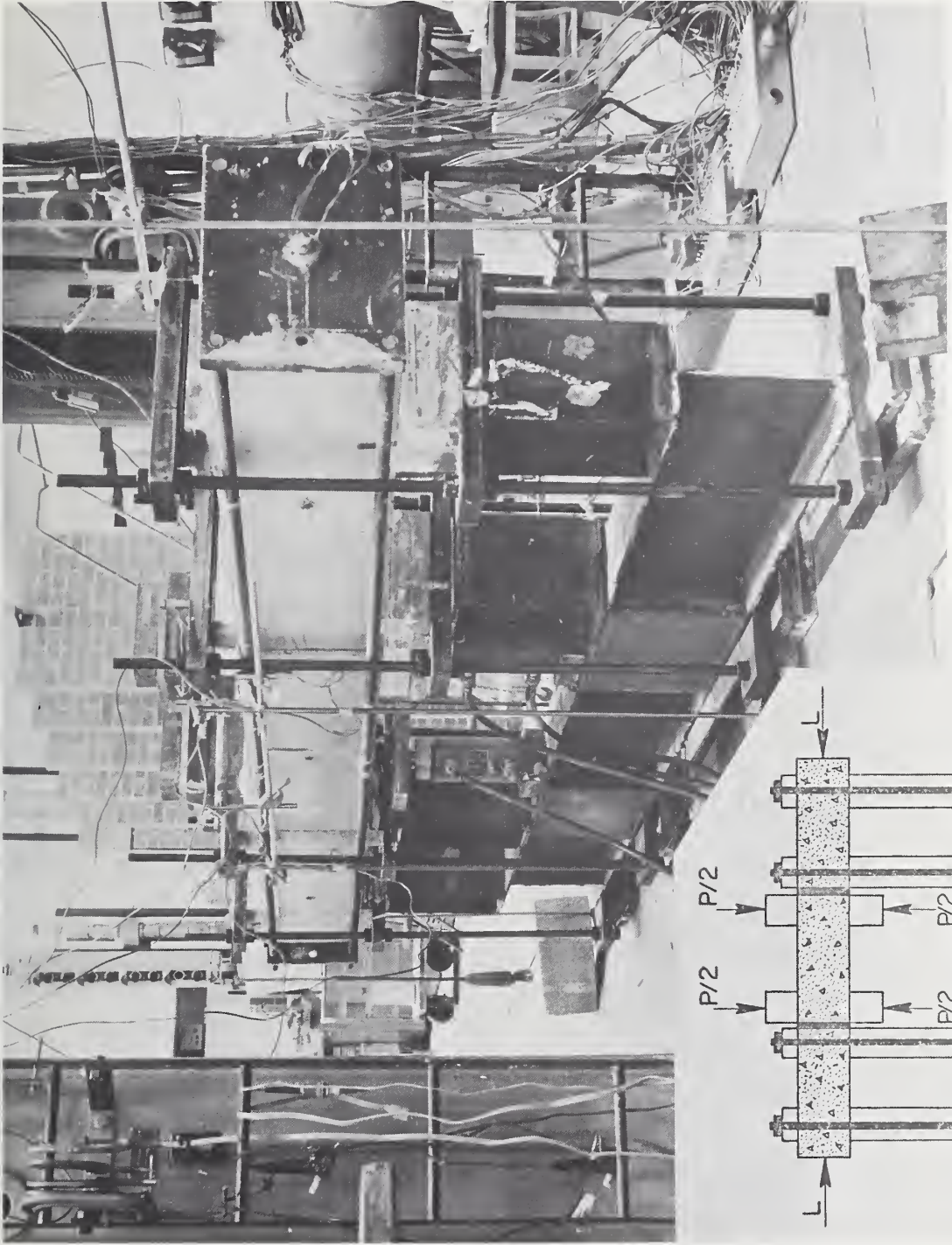

FIGURE 4.23 ARRANGEMENT FOR SHEAR TESTS 2 AND 3

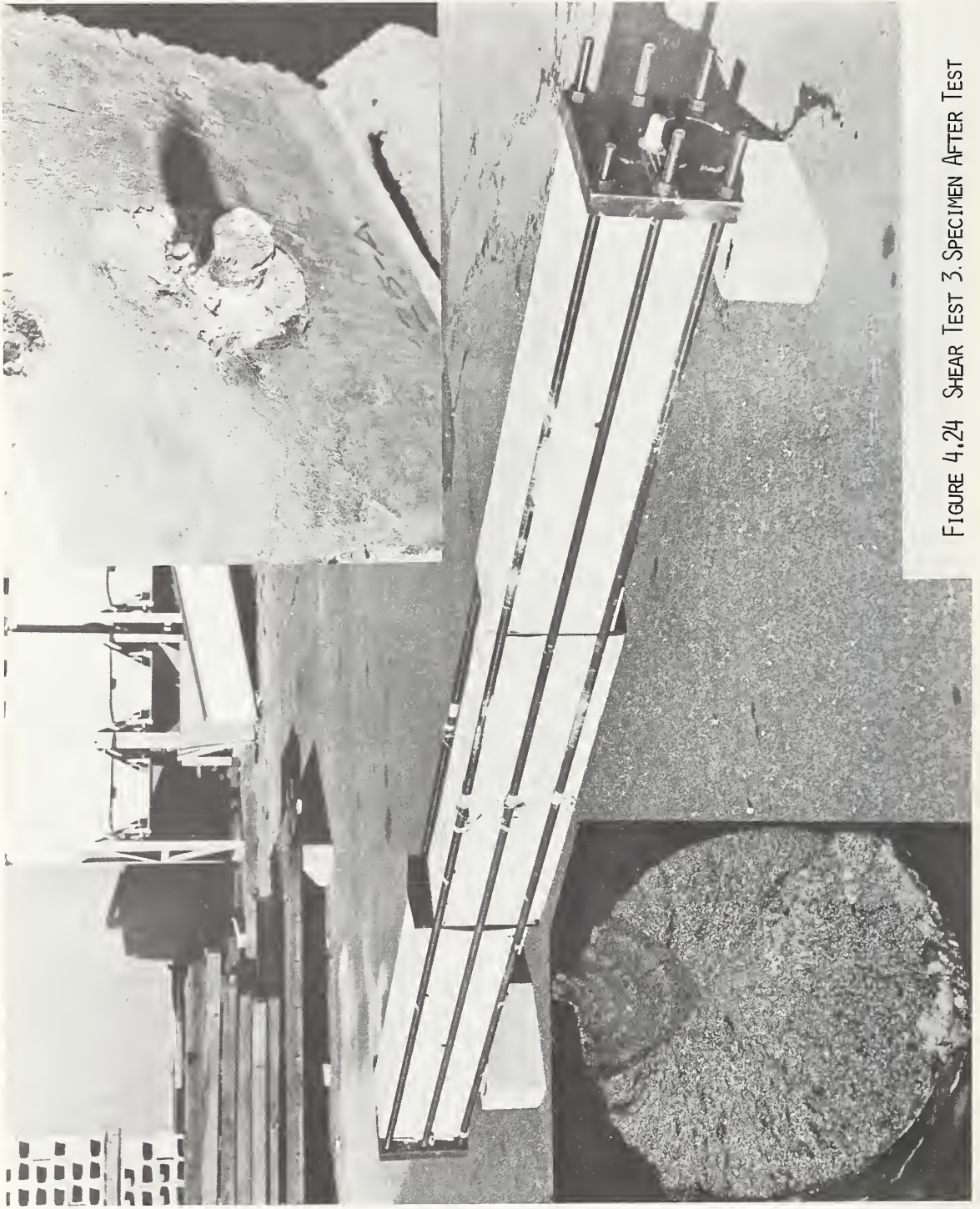

FIGURE 4.24 SHEAR TEST 3. SPECIMEN AFTER TEST

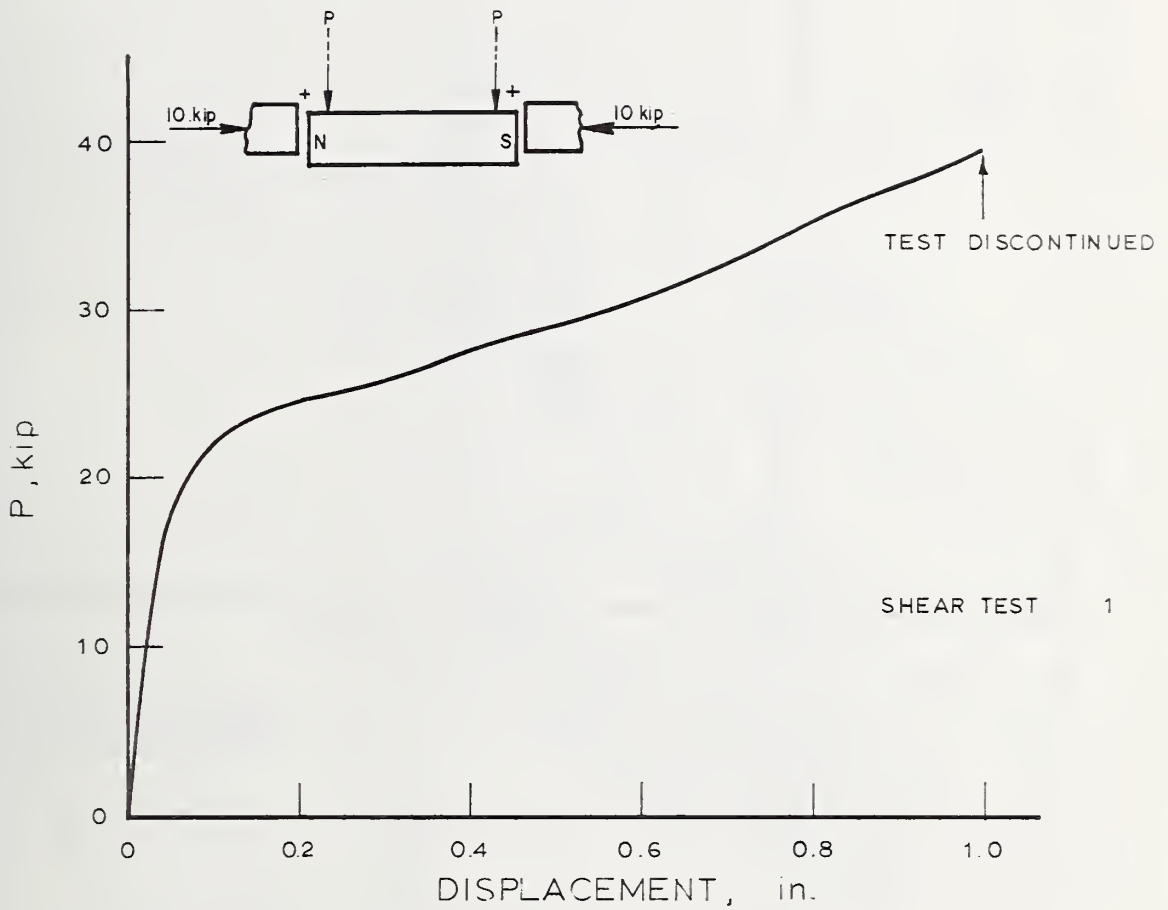

FIGURE 4.25 VERTICAL DISPLACEMENTS OF SOUTH END OF CENTER SEGMENT IN SHEAR TEST 1

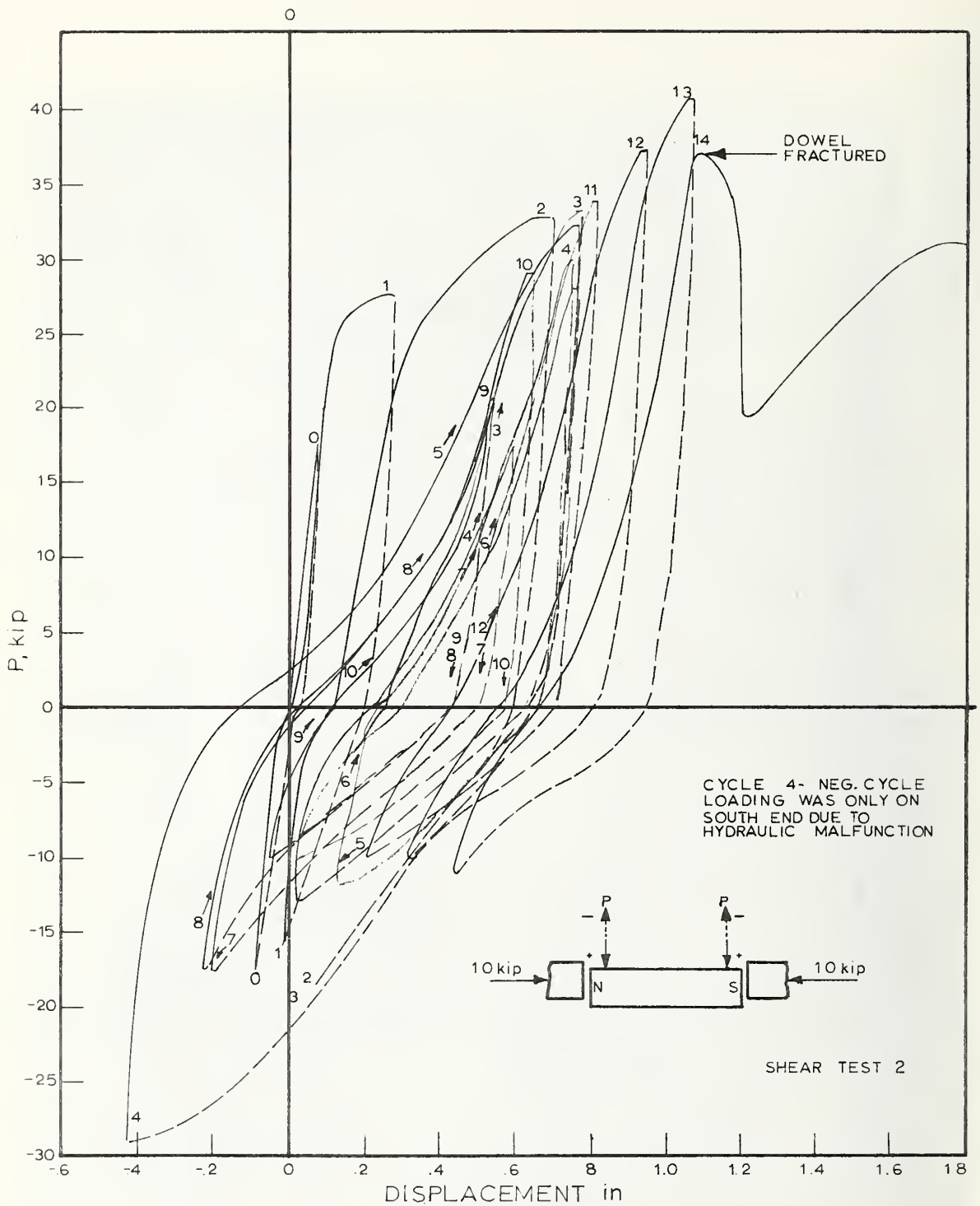

FIGURE 4.26 VERTICAL DISPLACEMENT OF SOUTH END OF CENTER SEGMENT IN SHEAR TEST 2

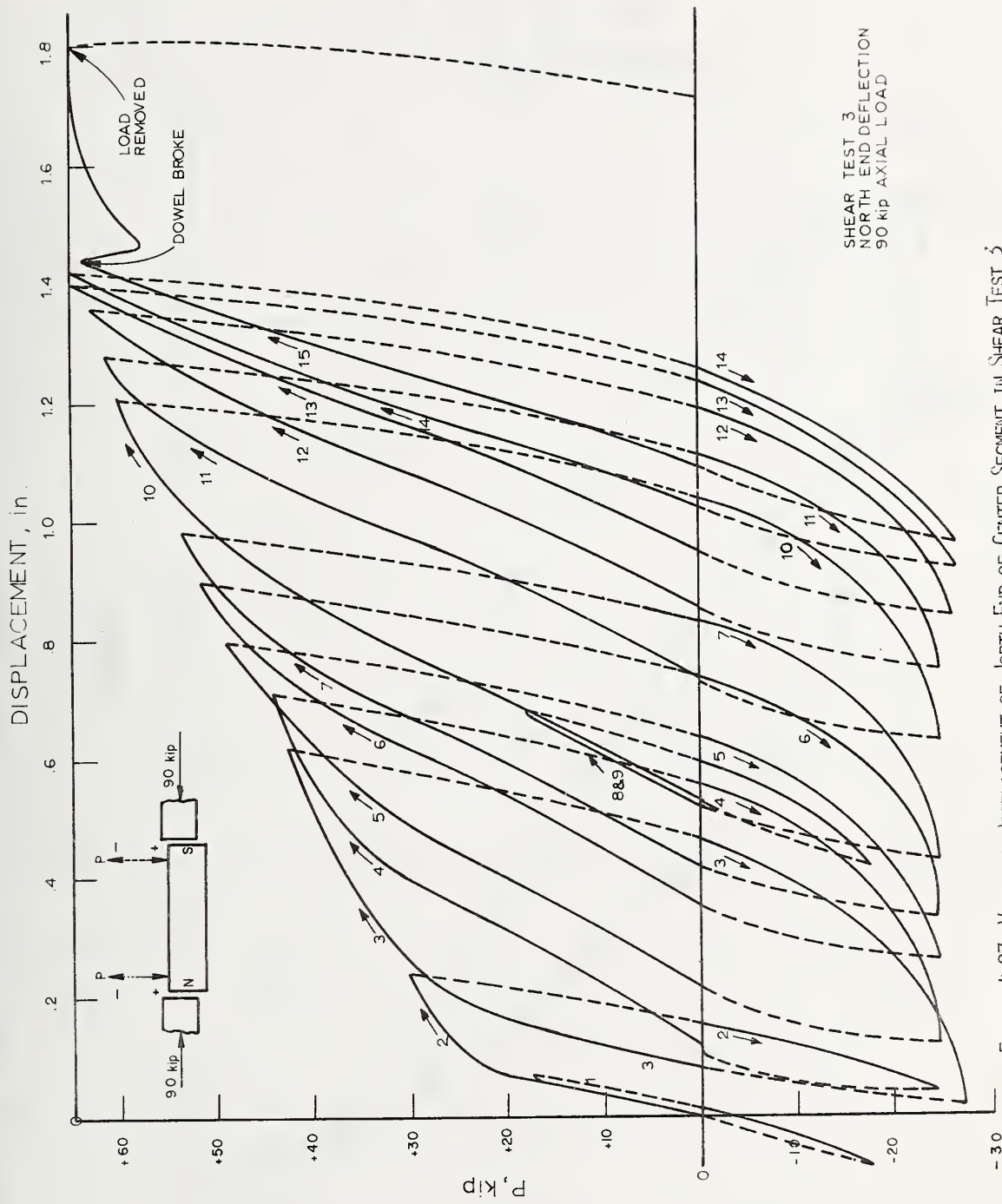

FIGURE 4.27 VERTICAL DISPLACEMENT OF NORTH END OF CENTER SEGMENT IN SHEAR TEST 3

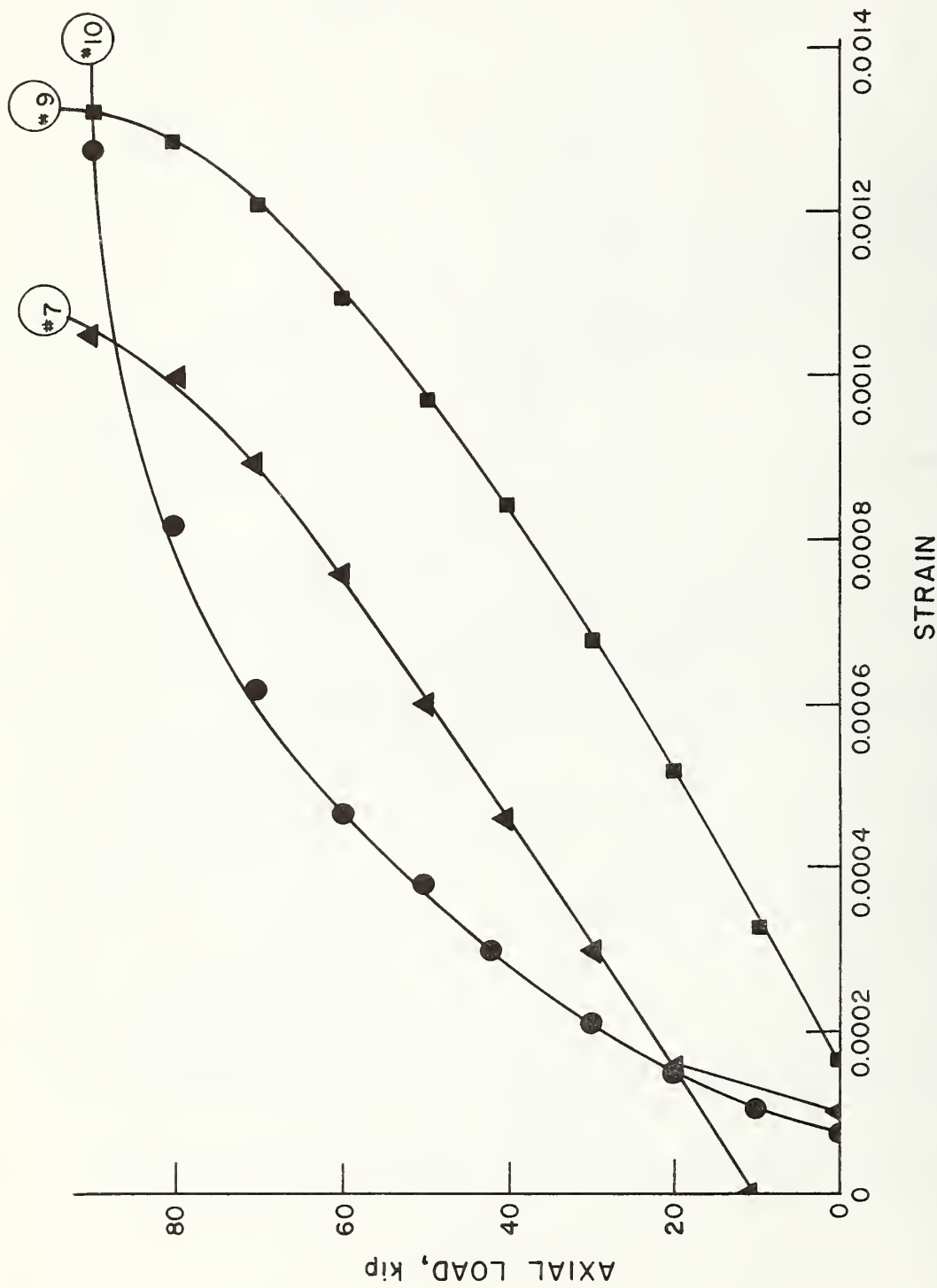

FIGURE 4.28 DOWEL STRAIN CAUSED BY AXIAL LOADING OF THE SPECIMEN IN SHEAR TEST 3

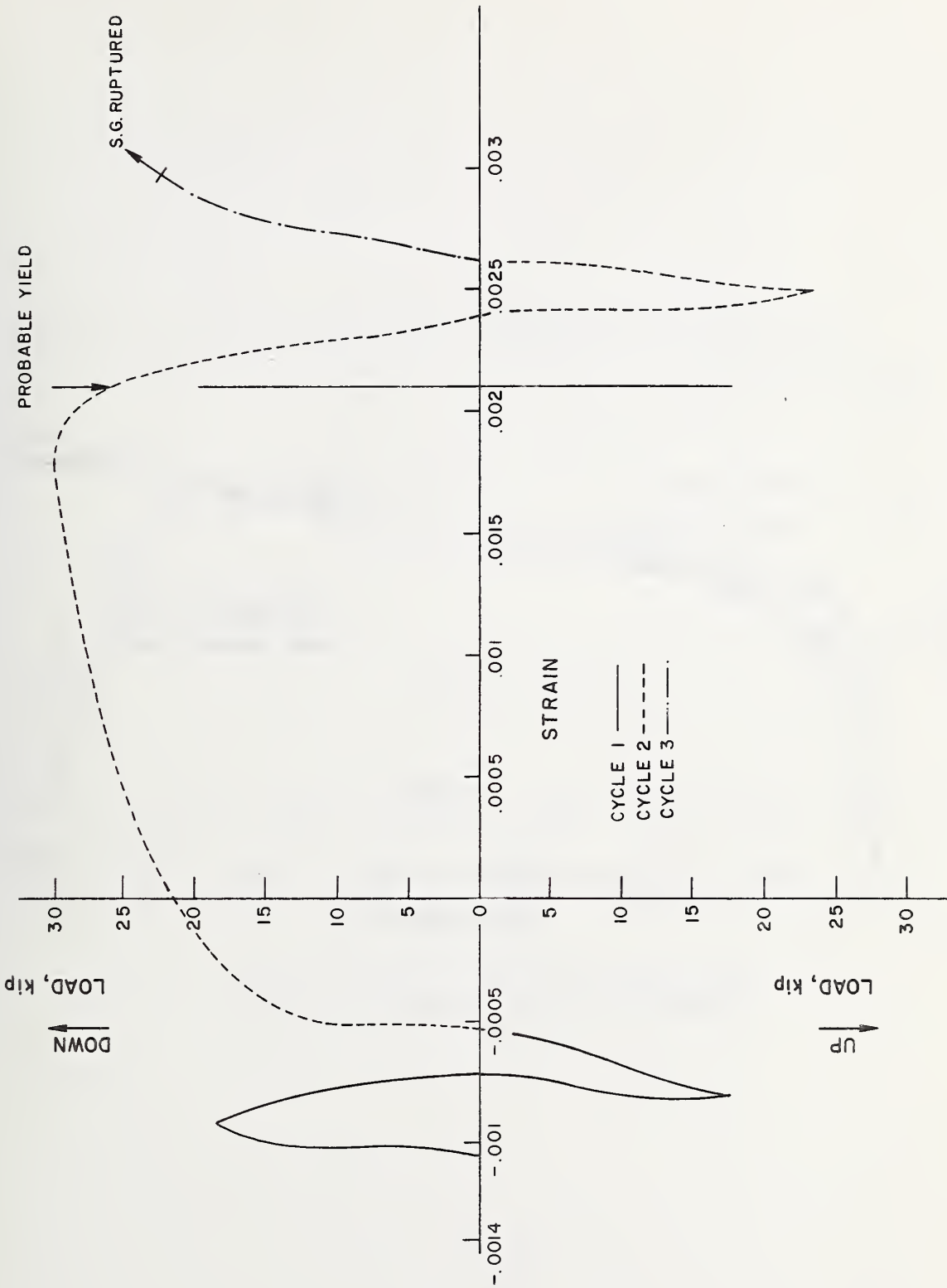

FIGURE 4.29 DOWEL STRAIN IN SHEAR TEST 3 RECORDED BY STRAIN GAGE #7

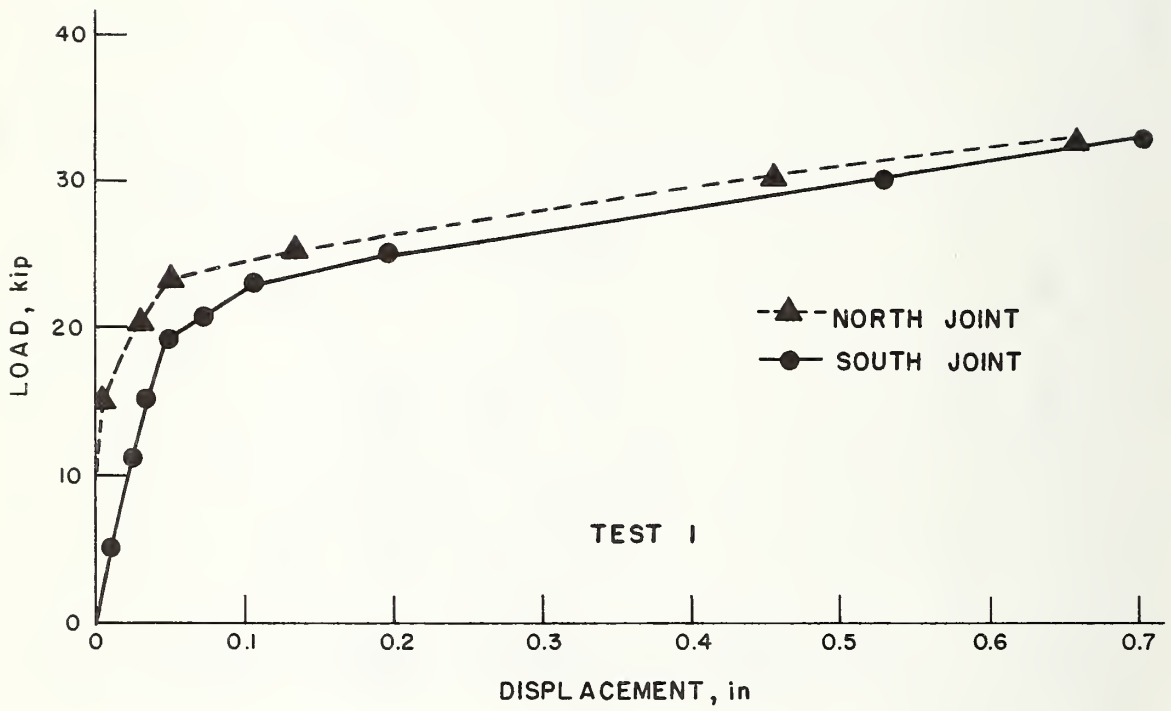

FIGURE 4.30 NET JOINT DISPLACEMENT IN SHEAR TEST 1

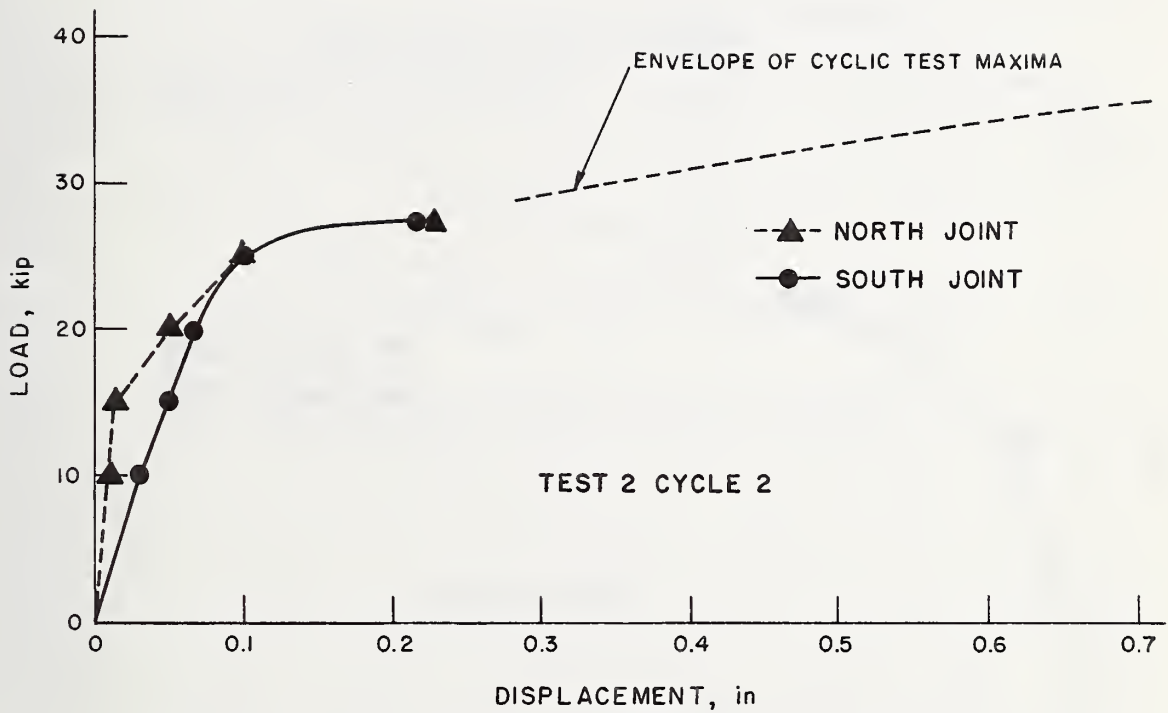

FIGURE 4.31 NET JOINT DISPLACEMENTS IN SHEAR TEST 2

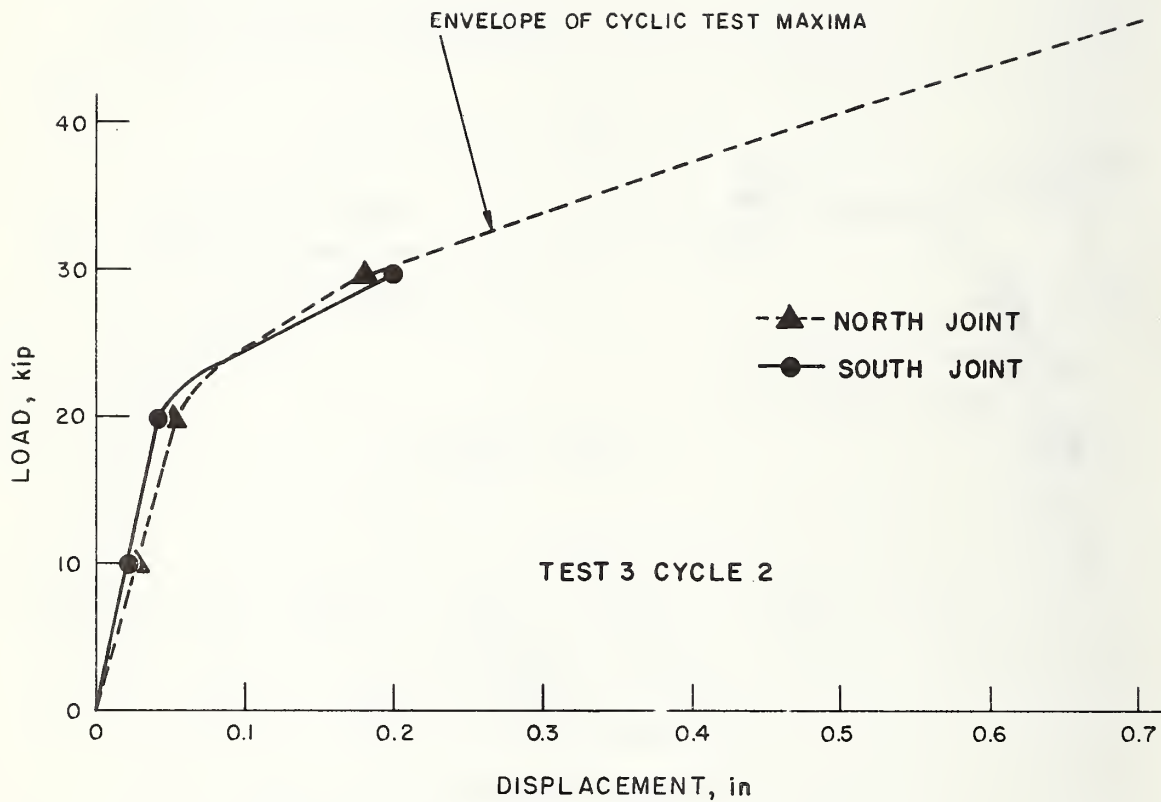

FIGURE 4.32 NET JOINT DISPLACEMENTS IN SHEAR TEST 3

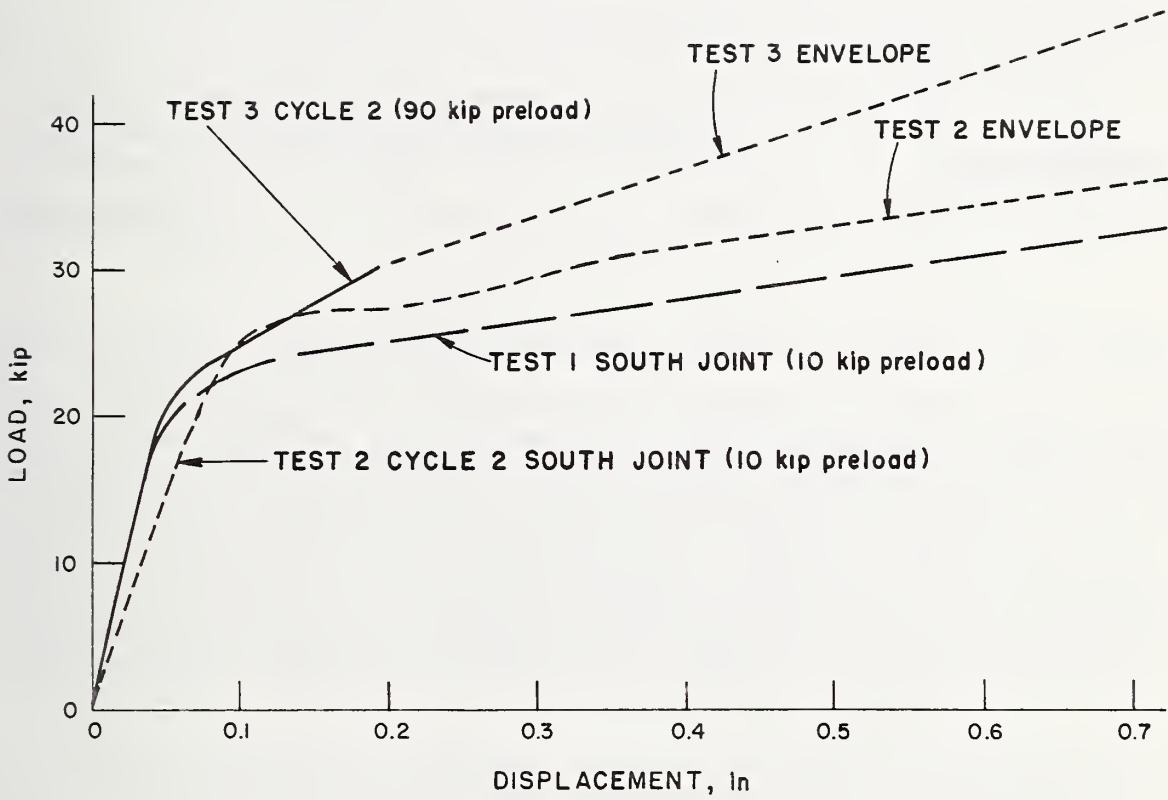

FIGURE 4.33 COMPARISON OF NET JOINT DISPLACEMENTS IN SHEAR TESTS 1, 2, AND 3.

U.S. DEPT. OF COMM. BIBLIOGRAPHIC DATA SHEET	1. PUBLICATION OR REPORT NO. NBSIR 73-148	2. Gov't Accession No.	3. Recipient's Accession No.
4. TITLE AND SUBTITLE Evaluation of the Column Connections Used in a Precast Concrete Modular Housing System		5. Publication Date	6. Performing Organization Code
7. AUTHOR(S) Felix Y. Yokel; Thomas W. Reichard		8. Performing Organization NBSIR 73-148	
9. PERFORMING ORGANIZATION NAME AND ADDRESS NATIONAL BUREAU OF STANDARDS DEPARTMENT OF COMMERCE WASHINGTON, D.C. 20234		10. Project/Task/Work Unit No. 4600431	11. Contract/Grant No. IAA-H-16-70
12. Sponsoring Organization Name and Address Office of Research and Technology Department of Housing and Urban Development Washington, D. C. 20410		13. Type of Report & Period Covered Final	14. Sponsoring Agency Code
15. SUPPLEMENTARY NOTES			
<p>16. ABSTRACT (A 200-word or less factual summary of most significant information. If document includes a significant bibliography or literature survey, mention it here.)</p> <p>The column connections used in a housing system employing stacked precast concrete box modules were tested to evaluate their structural performance. The system was proposed for construction in Operation BREAKTHROUGH, a research and demonstration program sponsored by the Department of Housing and Urban Development. The system uses innovative structural design concepts, which include: confinement of the concrete in the vicinity of the column bearings by reinforcing ties in order to increase concrete compressive strength; neoprene pads between column bearings in the upper stories, stories; steel-neoprene-steel sandwich in the lower stories; and a grouted dowel through the center of the columns to provide resistance to tension and shear.</p> <p>The test program included the following: tests to determine the effect of various bearing pads on the load capacity of the connection; tests to determine the load-deformation characteristics of the neoprene pads; a test to determine the performance of a lower-story connection using a steel-neoprene-steel sandwich and a grouted dowel; and tests to evaluate the strength and ductility of the connections when subjected to a shear force. The test results are presented and interpreted and the findings are summarized.</p>			
17. KEY WORDS (Alphabetical order, separated by semicolons) Building system; column connection; concrete triaxial strength; ductility; neoprene bearing pad; Operation BREAKTHROUGH; performance tests; precast concrete; structural design.			
18. AVAILABILITY STATEMENT <input checked="" type="checkbox"/> UNLIMITED. <input type="checkbox"/> FOR OFFICIAL DISTRIBUTION. DO NOT RELEASE TO NTIS.		19. SECURITY CLASS (THIS REPORT) UNCLASSIFIED	21. NO. OF PAGES
		20. SECURITY CLASS (THIS PAGE) UNCLASSIFIED	22. Price

