



FEB 1 1. 1934

U. S. DEPARTMENT OF COMMERCE



BUILDING
MATERIALS
AND
STRUCTURES

REPORT BMS10

Structural Properties of One of the
"Keystone Beam Steel Floor"
Constructions Sponsored by
the H. H. Robertson Company

by

HERBERT L. WHITTEMORE

AMBROSE H. STANG, *and*

CYRUS C. FISHBURN



NATIONAL
BUREAU OF STANDARDS



The program of research on building materials and structures undertaken by the National Bureau of Standards is planned with the assistance of the following advisory committee designated by the Subcommittee on Design and Construction of the Central Housing Committee.

TECHNICAL RESEARCH GROUP

WALTER JUNGE, Federal Housing Administration, *Chairman*
A. C. SHIRE, United States Housing Authority, *Vice Chairman*

A. G. BEAR, Veterans' Administration.	CHARLES E. MAYETTE, United States Housing Authority.
PIERRE BLOUKE, Home Owners' Loan Corporation.	VINCENT B. PHELAN, National Bureau of Standards.
C. W. CHAMBERLAIN, Procurement Division.	E. A. POYNTON, Bureau of Indian Affairs.
JOS. M. DALLAVALLE, Public Health Service.	JOHN H. SCHAEFER, Procurement Division.
HUGH L. DRYDEN, National Bureau of Standards.	GEORGE W. TRAYER, United States Forest Service.
G. E. KNOX, Bureau of Yards and Docks, Navy Department.	ELSMERE J. WALTERS, Quartermaster Corps, War Depart- ment.

STERLING R. MARCH, *Secretary*.

The program is administered and coordinated by the following staff committee of the Bureau:

HUGH L. DRYDEN, *Chairman*

P. H. BATES	W. E. EMLEY	A. S. McALLISTER
H. C. DICKINSON	G. E. F. LUNDELL	H. S. RAWDON

The Forest Products Laboratory of the United States Department of Agriculture is cooperating with the National Bureau of Standards in studies of wood constructions.

How To Purchase

BUILDING MATERIALS AND STRUCTURES REPORTS

On request, the Superintendent of Documents, U. S. Government Printing Office, Washington, D. C., will place your name on a special mailing list to receive notices of new reports in this series as soon as they are issued. There will be no charge for receiving such notices.

An alternative method is to deposit with the Superintendent of Documents the sum of \$5.00, with the request that the reports be sent to you as soon as issued, and that the cost thereof be charged against your deposit. This will provide for the mailing of the publications without delay. You will be notified when the amount of your deposit has become exhausted.

If 100 copies or more of any report are ordered at one time, a discount of 25 percent is allowed.

Send all orders and remittances to the *Superintendent of Documents, U. S. Government Printing Office, Washington, D. C.*

UNITED STATES DEPARTMENT OF COMMERCE · Daniel C. Roper, Secretary
NATIONAL BUREAU OF STANDARDS · Lyman J. Briggs, Director

BUILDING MATERIALS *and* STRUCTURES

REPORT BMS10

Structural Properties of One of the
“Keystone Beam Steel Floor” Constructions
Sponsored by the H. H. Robertson Company

by HERBERT L. WHITTEMORE, AMBROSE H. STANG,
and CYRUS C. FISHBURN



ISSUED DECEMBER 29, 1938

The National Bureau of Standards is a fact-finding organization; it does not “approve” any particular material or method of construction. The technical findings in this series of reports are to be construed accordingly.

UNITED STATES GOVERNMENT PRINTING OFFICE · WASHINGTON · 1939
FOR SALE BY THE SUPERINTENDENT OF DOCUMENTS, WASHINGTON, D. C. · PRICE 10 CENTS

Foreword

THIS REPORT is one of a series issued by the National Bureau of Standards on the structural properties of constructions intended for low-cost houses and apartments. Practically all of these constructions were sponsored by groups within the building industry which advocate and promote the use of such constructions and which have built and submitted representative specimens as outlined in report BMS2, Methods of Determining the Structural Properties of Low-Cost House Constructions. The sponsor is responsible for the representative character of the specimens and for the detailed description given in each report. The Bureau is responsible for the accuracy of the test data.

This report covers only the load-deformation relations and strength of the structural element submitted when subjected to transverse, impact, and concentrated loads by standardized methods simulating the loads to which the element would be subjected in actual service. It may be feasible to determine later the heat transmission at ordinary temperatures and the fire resistance of this same construction and perhaps other properties.

The National Bureau of Standards does not "approve" a construction, nor does it express an opinion as to the merits of a construction for reasons given in reports BMS1 and BMS2. The technical facts on this and other constructions provide the basic data from which architects and engineers can determine whether a construction meets desired performance requirements.

LYMAN J. BRIGGS, *Director.*

Structural Properties of One of the "Keystone Beam Steel Floor" Constructions Sponsored by the H. H. Robertson Company

by HERBERT L. WHITTEMORE, AMBROSE H. STANG, and CYRUS C. FISHBURN

CONTENTS

	Page		Page
Foreword.....	II	IV. Floor <i>AG</i> —Continued.	
I. Introduction.....	1	1. Sponsor's statement—Con.	4
II. Sponsor and product.....	2	(b) Description.....	4
III. Specimens and tests.....	2	(c) Comments.....	4
IV. Floor <i>AG</i>	2	2. Transverse load.....	6
1. Sponsor's statement.....	2	3. Impact load.....	7
(a) Materials.....	2	4. Concentrated load.....	7
		V. Selected references.....	8

ABSTRACT

FOR THE PROGRAM on the determination of the structural properties of low-cost house constructions, the H. H. Robertson Co. submitted six specimens representing one of their cellular sheet-steel floor constructions. The specimens were fabricated with "FKX 18-18" panels covered by a concrete fill and a "Hubbellite" composition finish floor.

The specimens were subjected to transverse, impact, and concentrated loads. For each of these loads three like specimens were tested, the concentrated-load tests being made on undamaged portions of the specimens used for the impact tests. The deformation under load and the set after the load was removed were measured for uniform increments of load, except for concentrated loads, for which the set only was determined. The strength under transverse load was also determined. The results are presented graphically and in a table.

I. INTRODUCTION

IN ORDER to provide technical facts on the performance of constructions which might be used in low-cost houses, to discover promising constructions, and ultimately to determine the properties necessary for acceptable performance, the National Bureau of Standards has invited the building industry to cooperate in a program of research on building materials and structures for use in low-cost houses and apartments. The objectives of this program are described in report BMS1, Research on Building Materials

and Structures for Use in Low-Cost Housing,¹ and that part of the program relating to structural properties in report BMS2, Methods of Determining the Structural Properties of Low-Cost House Constructions.²

Conventional wood-frame constructions, including those for floors, have been subjected by the Forest Products Laboratory of the United States Department of Agriculture to a series of standardized laboratory tests to provide data on the properties of some constructions for which the behavior in service is generally known. These data will be given in a subsequent report in this series.

This report describes the structural properties of a floor construction sponsored by one of the manufacturers in the building industry. The specimens were subjected to transverse, impact, and concentrated loads, simulating loads to which the floor of a house is subjected. In actual service, transverse loads are applied to floors by furniture and by the occupants; impact loads by objects falling on the floor or by persons jumping on the floor; and concentrated loads by furniture, for example, the legs of a piano.

The deflection and set under each increment of load were determined except for concentrated loads. For some of the newer con-

¹ Price 10 cents. See cover page II.

² Price 10 cents.

structions, the deflection and set are important when judging whether the construction will be satisfactory in a house under service conditions. The strength under transverse load was also determined.

II. SPONSOR AND PRODUCT

THE SPECIMENS were submitted by the H. H. Robertson Co., Pittsburgh, Pa., and represented one of their floor constructions marketed under the trade name "Robertson Keystone Beam Steel Floor." The floor consisted of cellular sheet-steel panels, which were the principal structural members. The upper face was covered by a concrete fill and a finish floor of magnesium oxychloride-cement composition. The lower face was covered with oil paint.

III. SPECIMENS AND TESTS

THE FLOOR construction was assigned the symbol *AG* and the specimens were assigned designations in accordance with table 1.

TABLE 1.—*Specimen designations*

Specimen designation	Load	Load applied
<i>T1, T2, T3</i>	Transverse.....	Upper face.
<i>I1, I2, I3</i>	Impact.....	Do.
<i>P1, P2, P3</i> ^a	Concentrated.....	Do.

^a These specimens were undamaged portions of the specimens used for the impact tests.

The specimens were tested in accordance with BMS2, Methods of Determining the Structural Properties of Low-Cost House Constructions,³ which also gives the requirements for the specimens and for determining the price.

The specimens were tested on January 12 and 13, 1938, when the age of the concrete fill was 42 days and of the finish floor about 22 days. The sponsor's representative witnessed the tests.

IV. FLOOR *AG*

1. SPONSOR'S STATEMENT

(a) *Materials*

Steel.—Hot-rolled black sheets. The chemical composition of the steel is given in table 2 and the specified mechanical properties in table 3. Carnegie-Illinois Steel Co.

³ Price 10 cent. 18.

TABLE 2.—*Chemical composition of the steel*

Element	Content
	Percent
Carbon.....	0.075
Manganese.....	.31
Phosphorous.....	.012
Sulfur.....	.034

TABLE 3.—*Specified mechanical properties of the steel*

Yield point		Tensile strength		Elongation in 2 in.	
Minimum	Maximum	Minimum	Maximum	Minimum	Maximum
<i>lb/in.²</i> 35,000	<i>lb/in.²</i> 50,000	<i>lb/in.²</i> 45,000	<i>lb/in.²</i> -----	Percent 25	Percent 35

Welds.—Spot welds, $\frac{3}{8}$ -in. diam, automatic. Before making welds in production the welding machine was adjusted and specimen welds tested by wedging the sheets apart with a cold chisel. The adjustment was satisfactory when not less than 90 percent of the specimens failed by the weld pulling out of the thinner sheet. Specimens were tested also at intervals after welding not more than 500 floor panels.

Are welds, manual.

Enamel.—The coating liquid was specified to contain not more than 7 percent of mineral pigment ground in not less than 93 percent of water-resisting spar varnish, and sufficient volatile thinner so that the steel, when removed from the dipping bath, would be coated uniformly without wrinkles, "livered" spots, beads, or "icicles." The pigment was specified to be carbon black, obtained wholly from the incomplete combustion of artificial gas, and containing not more than 3 percent of ash. The thinner was specified to be turpentine, aliphatic hydrocarbon, aromatic hydrocarbon, or a mixture of these.

The floor panels were coated by dipping, then baking at 275° to 300° for 30 to 40 min.

The enamel finish, when applied to a piece of taggers metal (tin plate, No. 36 U. S. Standard Gage or lighter) and properly baked, was specified to pass the following tests after aging 7 days: (a) Cold-bending around a $\frac{1}{8}$ -in. diam mandrel at 65° F, without separating from the metal or cracking; (b) when struck with a hammer the enamel shall not chip or crack from the

metal; (c) when scraped with a pointed instrument the enamel shall not powder or flake; and (d) when painted over with a light-colored paint, the enamel shall not bleed through. H. H. Robertson Company's "No. 345 Floor Enamel" prepared by the M. B. Suydam Co.

Concrete.—Truck-mixed, containing 1 part of portland cement, 3.6 parts of sand, and 5.5 parts of gravel (maximum size $\frac{3}{4}$ in.) by weight. The concrete was delivered in two loads. Load 1 was 2 yd³ and load 2 was 1½ yd³.

The following properties of the concrete were determined by the Masonry Construction Section of the National Bureau of Standards. For each load the slump was determined and three 6- by 12-in. cylinders were made. The cylinders were stored in air near the floor specimens. The compressive strength of the cylinders was determined on the day the floor specimens were tested, at an age of 42 days. The physical properties of the concrete are given in table 4.

TABLE 4.—Physical properties of the concrete

Load number	Slump	Compressive strength
1.....	in. $5\frac{5}{8}$	lb/in. ² 2,820
2.....	1½	1,750

"Hubbellite."—Magnesium oxychloride-cement composition containing finely divided copper. This is a recent development by the

H. H. Robertson Company's Fellowship at the Mellon Institute of Industrial Research.

There were two layers designated base and top coats. The base coat, used to level up the fill, was not pigmented and contained fibrous aggregate. The top coat was pigmented red for some of the specimens and green for the others and contained a dense grading of hard aggregate designed to finish well under the trowel. The red top coat contained 2 percent of iron oxide and the green top coat contained 1½ percent of chromium oxide.

The following properties of the "Hubbellite" were determined by the Masonry Construction Section of the National Bureau of Standards. Three 2-in. cubes and three briquettes were made for the base coat and for each of the red and green top coats. They were stored in air near the floor specimens. The compressive strength of the cubes and the tensile strength of the briquettes were determined on the day the floor specimens were tested, at an age of 23 days for the base coat and 22 days for the top coats. The physical properties of the "Hubbellite" are given in table 5.

TABLE 5.—Physical properties of the "Hubbellite"

Coat	Compressive strength	Tensile strength
Base.....	lb/in. ² 4,890	lb/in. ² 660
Top, red.....	8,250	1,120
Top, green.....	7,700	1,060

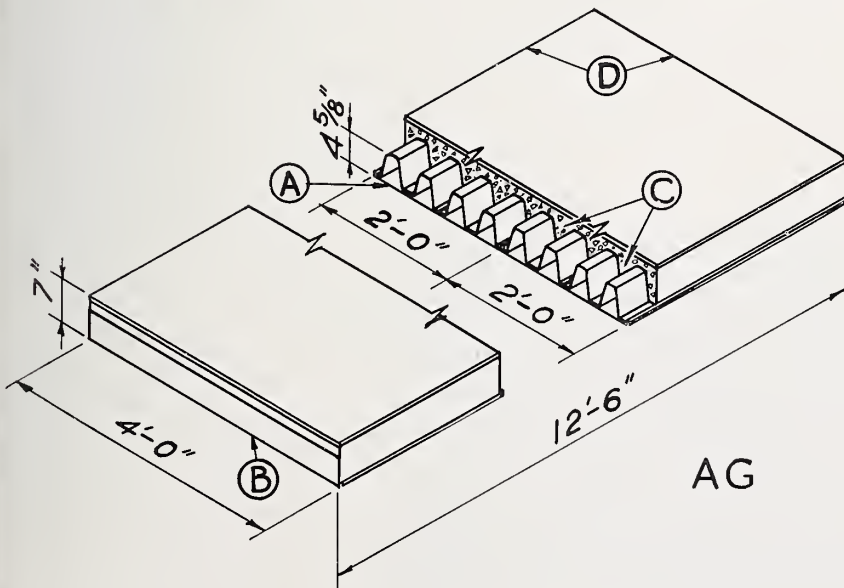

FIGURE 1.—Floor specimen AG.

A panel; B, end member; C, fill; D, finish floor.

Oil paint.—A commercial oil paint.

(b) *Description*

The floor specimens were 12 ft 6 in. long, 4 ft 0 in. wide, and 7 in. thick. Each specimen consisted of two standard sheet-steel floor panels, *A*, as shown in figure 1, enclosed at the ends by sheet-steel end members, *B*, and a concrete fill, *C*, over which was a "Hubbellite" composition finish floor, *D*. The lower faces of the specimens were covered with oil paint.

The price of this construction was \$0.59/ft².

Panels.—The two panels, *A*, were standard "FKX 18-18" floor panels, 2 ft 0 in. wide and 4 $\frac{3}{8}$ in. thick. Each panel consisted of a sheet-steel face, as shown in figure 2, and two sheet-steel formed sections fastened to the face by spot welds, spaced approximately 2 in. on centers in double rows. The face and the formed sections were sheet-steel, No. 18 United States Standard Gage (0.049 in. thick). The face had a male lip along one edge and a female lip along the other edge. The lips on adjacent panels interlocked. The panels and also the end members, were completely coated on both inside and outside with baked-on enamel.

End members.—The end members, *B*, were channels, 2 $\frac{7}{32}$ by 4 $\frac{31}{32}$ by 2 $\frac{19}{32}$ in., 4 ft 0 in. long, formed from sheet-steel, No. 12 United States Standard Gage (0.1072 in. thick). The webs of the end members were in contact with the ends of the panels and the flanges were fastened to the panels by arc welds.

Fill.—The fill, *C*, was concrete screeded to 1 $\frac{1}{8}$ in. above the panels. Load 1 of concrete was used for specimens *T2*, *T3*, and most of *I2* and *I3*. Load 2 was used for the remainder of *I2* and *I3* and for all of specimens *I1* and *T1*.

Finish floor.—The finish floor, *D*, was "Hubbellite" composition and consisted of a base coat and a pigmented top coat. Each coat was about $\frac{3}{8}$ in. thick. The top coats of specimens *I1*, *I3*, *T1*, and about three-fourths of the length of *T3* were red. The top coats of specimens *I2* and *T2* and the remainder of *T3* were green.

(c) *Comments*

The "Keystone Beam" steel floors have been used in approximately 900 buildings up to June 1, 1938. About 70 of these buildings were dwellings.

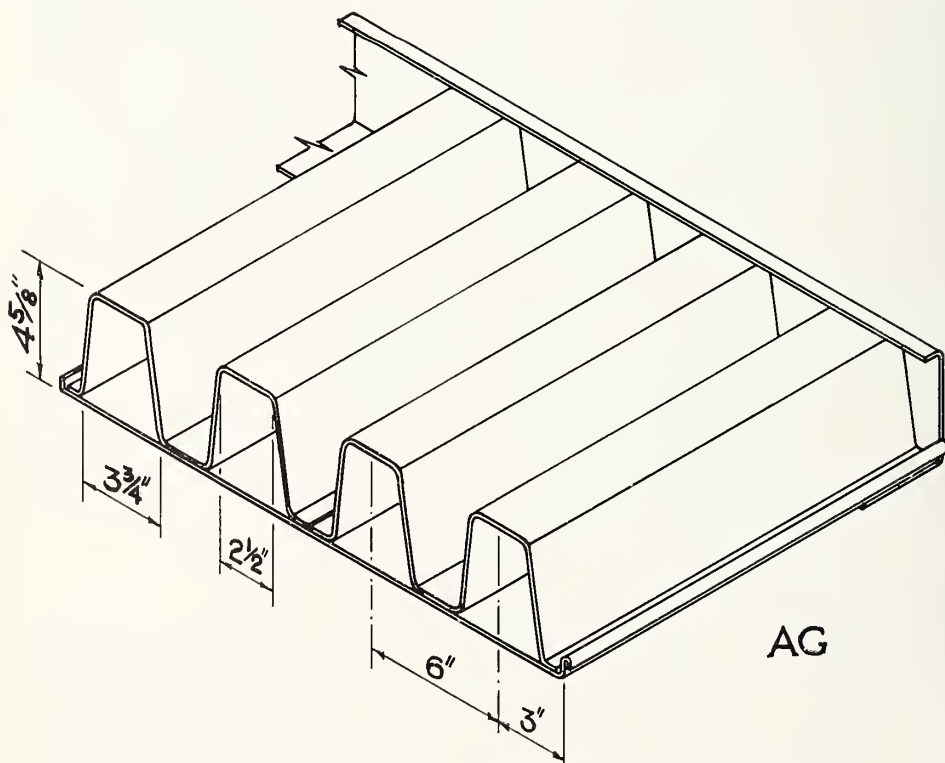

FIGURE 2.—Floor panel *A* and end member *B*.

The standard panels are 2 ft 0 in. wide and up to 24 ft long. The panels recommended for low-cost houses and apartments are types "FK", "FKX", "UK", and "UKX", formed from either No. 18 or No. 16 United States Standard Gage steel. The "FK" panels are the same as the "FKX" panels described in this report but are used with the flat surface up. The "UK" and "UKX" panels, which are alike but used with opposite surfaces up, have four cells, each 1½ in. deep and 4 in. wide.

The floor panels are designed to be framed into conventional steel and masonry buildings without the use of temporary supports during erection. The panels may extend from wall to wall if the span does not exceed 20 ft for types "FK" and "FKX", and 10 ft for types "UK" and "UKX"; or, they may extend from the wall to an intermediate beam, with the same limitation of span.

The panels are connected laterally by the interlocking metal lips. The ends are enclosed by a continuous channel when the bearing is on an outside masonry wall. When the bearing is on an inside masonry wall, a flat bearing plate is used on top of the wall and the panels are aligned end to end. Similarly, when the bearing is on an intermediate beam, the flange of the beam provides a level bearing. The panels are fastened to the steel framework by arc welds or by hardened self-tapping drive screws. The panels are fastened to masonry walls by building the end members into the masonry or by fastening the panels to a plate or a shelf angle, which in turn is anchored to the masonry by hook bolts or wall anchors.

The concrete fill is poured directly on the steel without the use of forms. The finish floor

may be repressed brick, mastic tile, masonite, wood parquetry, rubber tile, "Hubbellite," etc.; or, the concrete fill may be used without covering.

The lower faces of the panels usually form the ceiling of the room below and may be finished by any of the following methods after first cleaning to remove all oil, grease, and dirt:

The first method is to apply any good oil paint to hide the black baked-on enamel. The panel joints may be pointed with putty before the paint is applied.

The second method is a more elaborate treatment using paint. Any areas where the baked-on enamel has been seared or abraded are spot-primed and sanded, the panel joints and the spot welds are pointed with putty and sanded after drying, if necessary, then a coat of white or colored semigloss enamel is applied. Over the coat of semigloss enamel any of the following decorative paints may be applied: (a) plastic paint, (b) stipple paint, (c) flat paint, (d) semigloss paint, (e) undercoater and enamel, or (f) quick-drying enamel.

The third method, for flat ceilings, is to apply plaster about ¼ in. thick, in two coats. The materials recommended for the base coat, in the order of preference, are (a) gypsum neat plaster (fibered) and vermiculite; (b) gypsum neat plaster (fibered), vermiculite, and sand; (c) gypsum neat plaster (fibered) and sand; and (d) wood-fibered gypsum plaster with no other aggregate. The base coat should be from ⅜ to ¼ in. thick and worked into the panel joints, then screeded lightly to level, and broomed. Special precautions should be taken to keep the evaporation of water from the base coat at a minimum while setting. After set-

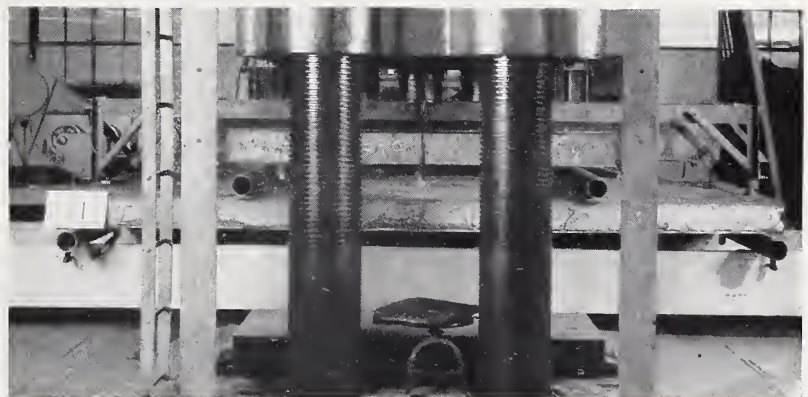

FIGURE 3.—Floor specimen AG-T1 under transverse load.

2. TRANSVERSE LOAD

Because of delay in applying the finish floor to the specimens they could not be tested 28 days after they were built. As a concession to the sponsor they were tested at an age of 42 days.

Floor specimen *AG-T1* under transverse load is shown in figure 3. The results for floor specimens *AG-T1*, *T2*, and *T3* are shown in table 6 and in figure 4.

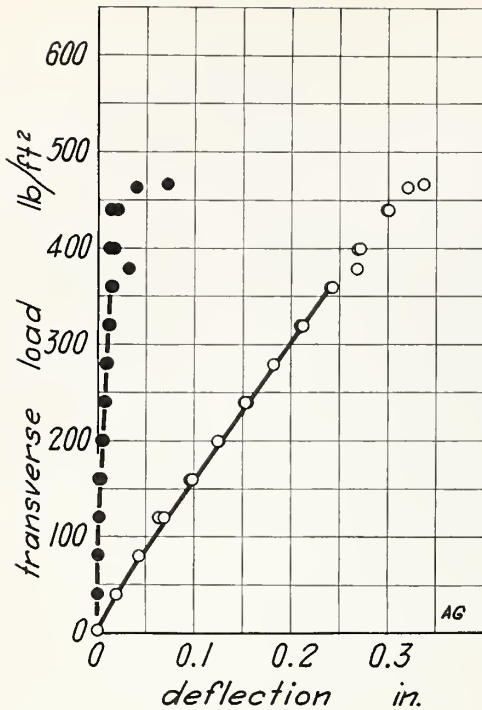

FIGURE 4.—Transverse load on floor *AG*.

Load-deflection and load-set results for specimens *AG-T1*, *T2*, and *T3* on the span 12 ft 0 in.*

ting, it should be dried quickly. Any desired skin or finish coat may be applied over the base coat.

TABLE 6.—Structural properties of floor *AG*

[Weight, 55.6 lb/ft²]

Load	Load applied	Specimen designation	Maxi-	Maxi-
			mum	
			height	load
			of drop	
			ft	lb/ft ²
Transverse.....	Upper face; span, 12 ft 0 in.	<i>T1</i>	577
		<i>T2</i>	546
		<i>T3</i>	541
Average.....	555
Impact.....	Upper face; span, 12 ft 0 in.	<i>I1</i>	^a 10.0
		<i>I2</i>	^a 10.0
		<i>I3</i>	^a 10.0
Average.....	^a 10.0
Concentrated.....	Upper face.....	<i>P1</i>	^a 1,000
		<i>P2</i>	^a 1,000
		<i>P3</i>	^a 1,000
Average.....	^a 1,000

*Specimen did not fail.

FIGURE 5.—Floor specimen *AG-I2* during the impact test.

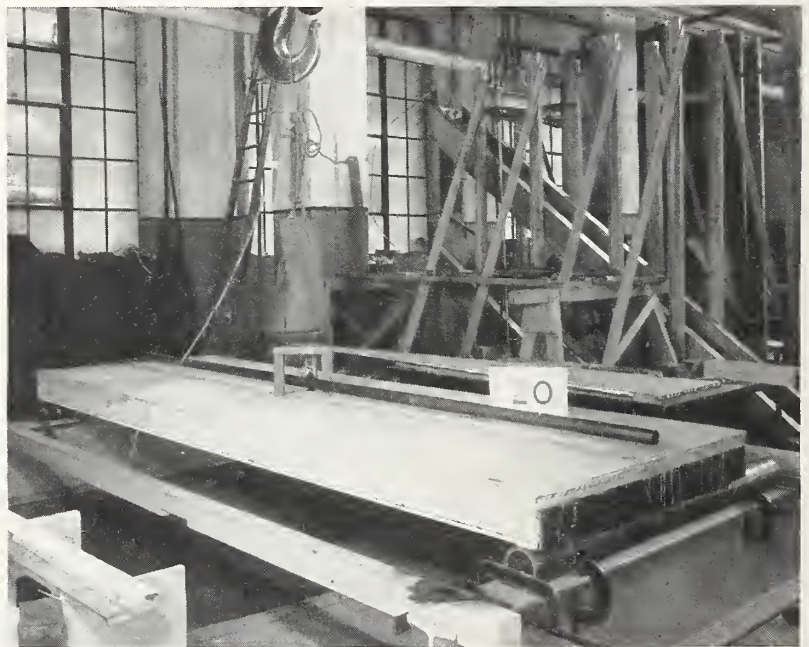

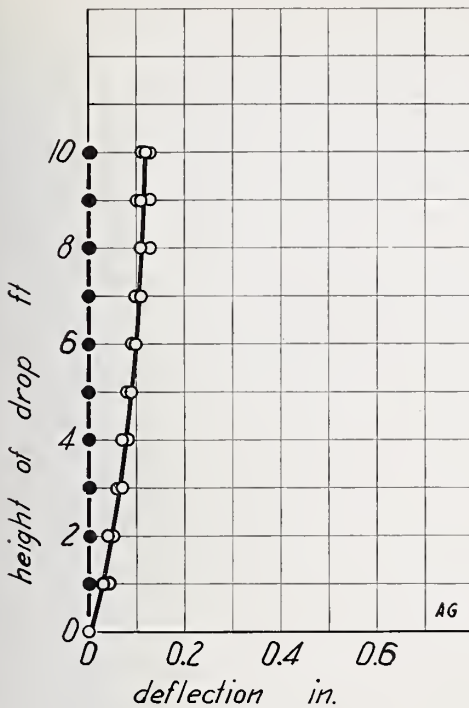

FIGURE 6.—Impact load on floor AG.

Height of drop-deflection and height of drop-set results for specimens AG-I1, I2, and I3 on the span 12 ft 0 in.

At loads of 466, 379, and 463 lb/ft², respectively, for specimens T1, T2, and T3, the load decreased suddenly during the application of an increment of load, although the platen of the testing machine continued to move at a uniform rate. At the instant the load started to decrease a sound indicated that the bond between the concrete fill and the panels had ruptured. There was no visible failure at these loads for specimens T1 and T2, and for specimen T3 only a horizontal crack on one edge between the loading rollers was noted. After the deflection and set readings for these loads were taken, the load was again increased and the maximum load and the failure determined.

Specimen T1 failed by cracking of the concrete fill and separating of the bottom of the concrete from the steel at the edges of the specimen. The finish floor cracked in two places near midspan. For specimen T2, the flange of one of the end members pulled out of the concrete fill, the bottom of the concrete separated from the steel at the edges of the specimen, and the concrete fill cracked near midspan. The finish floor sheared from the

concrete fill. For specimen T3, the concrete fill cracked at midspan and the flange of one of the end members pulled out of the concrete fill.

3. IMPACT LOAD

Floor specimen AG-I2, during the impact test, is shown in figure 5. The results for floor specimens AG-I1, I2, and I3 are shown in table 6 and in figure 6.

The sets after a drop of 10 ft were 0.002, 0.004, and 0.001 in. for specimens I1, I2, and I3, respectively, and no other effect was observed.

4. CONCENTRATED LOAD

Floor specimen AG-P1, under concentrated load, is shown in figure 7. The results for floor specimens AG-P1, P2, and P3 are shown in table 6 and in figure 8.

There was no measurable indentation for any of the specimens after a load of 1,000 lb had been applied.

The sponsor supplied the information contained in the sponsor's statement. The description and drawings of the specimens were prepared by E. J. Schell and G. W. Shaw of

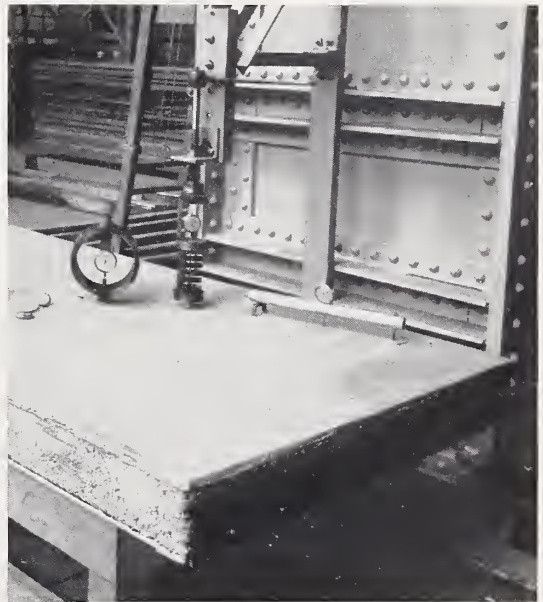

FIGURE 7.—Floor specimen AG-P1 under concentrated load.

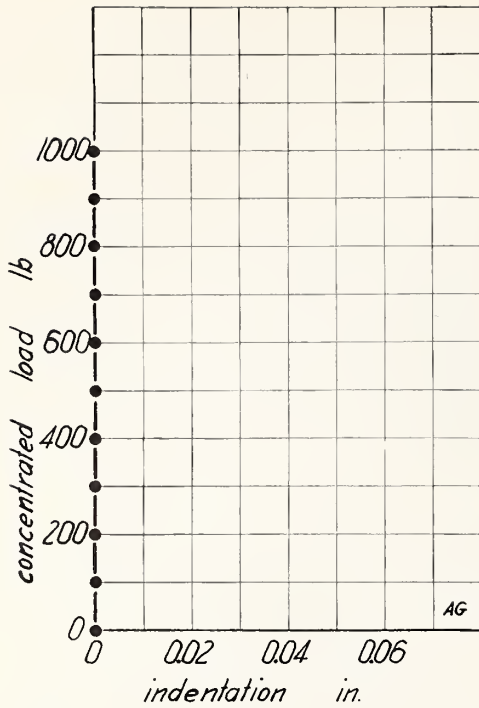

FIGURE 8.—Concentrated load on floor AG.
Load-indentation results for specimens AG-P1, P2, and P3.

the Bureau's Building Practice and Specifications Section, under the supervision of V. B. Phelan, from this information and from the specimens themselves. That Section also cooperated in the preparation of the report.

The experimental data were obtained from tests made by the Engineering Mechanics Section, under the supervision of H. L. Whittemore and A. H. Stang, and the Masonry Construction Section, under the supervision of D. E. Parsons, with the assistance of the following members of the professional staff: C. C. Fishburn, F. Cardile, R. C. Carter, H. Dollar, M. Dubin, A. H. Easton, A. S. Endler, C. D. Johnson, A. J. Sussman, and L. R. Sweetman.

V. SELECTED REFERENCES

- Am. Builder and Building Age **53**, No. 4, 35 (1932); **57**, No. 4, 88 (1935).
- Arch. Record **71**, No. 6, 413 (1932); **78**, No. 2, 120 (1935).
- Ind. Eng. Chem. **29**, 123 (1937).
- BS J. Research **9**, 131 (1932) RP463.

WASHINGTON, August 12, 1938.

○

The *National Bureau of Standards* was established by act of Congress, approved March 3, 1901, continuing the duties of the old Office of Standard Weights and Measures of the United States Coast and Geodetic Survey. In addition, new scientific functions were assigned to the new Bureau. Originally under the Treasury Department, the Bureau was transferred in 1903 to the Department of Commerce and Labor (now the United States Department of Commerce). It is charged with the development, construction, custody, and maintenance of reference and working standards, and their intercomparison, improvement, and application in science, engineering, industry, and commerce.

SUBJECTS OF BUREAU ACTIVITIES

- | | | |
|---|---|---|
| <i>Electricity</i> | <i>Chemistry</i> —Continued | <i>Simplified Practice</i> —Continued |
| Resistance Measurements | Organic Chemistry | Containers and Miscellaneous Products |
| Inductance and Capacitance | Metal and Ore Analysis, and Standard Samples | Materials-Handling Equipment and Ceramics |
| Electrical Instruments | Reagents and Platinum Metals | |
| Magnetic Measurements | Electrochemistry (Plating) | <i>Trade Standards</i> |
| Photometry | Gas Chemistry | Wood, Wood Products, Paper, Leather, and Rubber |
| Radio | Physical Chemistry | Metal Products |
| Underground Corrosion | Thermochemistry and Constitution of Petroleum | Textiles |
| Electrochemistry | | Apparel |
| Telephone Standards | <i>Mechanics and Sound</i> | Petroleum, Chemical, and Miscellaneous Products |
| <i>Weights and Measures</i> | Engineering Instruments and Mechanical Appliances | |
| Length | Sound | <i>Codes and Specifications</i> |
| Mass | Aeronautic Instruments | Safety Codes |
| Time | Aerodynamics | Building Codes |
| Capacity and Density | Engineering Mechanics | Building Practice and Specifications |
| Gas Measuring Instruments | Hydraulics | Producer Contacts and Certification |
| Thermal Expansivity, Dental Materials, and Identification | <i>Organic and Fibrous Materials</i> | Consumer Contacts and Labeling |
| Weights and Measures Laws and Administration | Rubber | |
| Large-Capacity Scale Testing | Textiles | <i>Office</i> |
| Limit Gages | Paper | Finance |
| <i>Heat and Power</i> | Leather | Personnel |
| Thermometry | Testing and Specifications | Purchase and Stores |
| Pyrometry | Fiber Structure | Property and Transportation |
| Heat Measurements | Organic Plastics | Mail and Files |
| Heat Transfer | <i>Metallurgy</i> | Library |
| Cryogenics | Optical Metallurgy | Information |
| Fire Resistance | Thermal Metallurgy | |
| Automotive Power Plants | Mechanical Metallurgy | <i>Shops</i> |
| Lubrication and Liquid Fuels | Chemical Metallurgy | Instrument |
| <i>Optics</i> | Experimental Foundry | Woodworking |
| Spectroscopy | <i>Clay and Silicate Products</i> | Glassblowing |
| Polarimetry | Whiteware | Construction Stores and Tool Room |
| Colorimetry and Spectrophotometry | Glass | |
| Optical Instruments | Refractories | <i>Operation of Plant</i> |
| Radiometry | Enameled Metals | Power Plant |
| Atomic Physics, Radium, and X-Rays | Heavy Clay Products | Electrical |
| Photographic Technology | Cement and Concreting Materials | Piping |
| Interferometry | Masonry Construction | Grounds |
| <i>Chemistry</i> | Lime and Gypsum | Construction |
| Paints, Varnishes, and Bituminous Materials | Stone | Guard |
| Detergents, Cements, Corrosion, Etc. | <i>Simplified Practice</i> | Janitorial |
| | Wood, Textiles, and Paper | |
| | Metal Products and Construction Materials | |

