

NOTE ON A PIEZO-ELECTRIC GENERATOR FOR AUDIO-FREQUENCIES

By August Hund

ABSTRACT

Crystals of quartz can be made to vibrate by electrical means and have been used in this way for some time as standards for the high frequencies used in radio apparatus, which give notes inaudible to the ear. To produce audible frequencies in this way would require a very large crystal. The Bureau of Standards has found that audible frequencies can be produced by using two small crystals which differ slightly in their periods of vibration and furnish a beat or difference in tone which lies within the limits of audibility.

I. METHODS OF OBTAINING AUDIO-FREQUENCIES FROM SMALL PIEZO-ELECTRIC PLATES

Piezo-electric generators for high frequencies are not new. They have been used for some time in radio work and have proved to be quite constant, especially when the crystal holder and circuit are carefully designed and when thermostatic control is provided. To produce audio-frequencies in this way would require a very large crystal. There are several possible arrangements of apparatus which will avoid this difficulty.

(a) Two independent generators whose difference in frequency produces an audible note.

(b) When two piezo-electric plates are connected in one and the same tube circuit it is possible to produce audio-frequencies. For this purpose the two crystals are best connected in parallel across the grid and filament of the tube.

(c) A single piezo-electric crystal with a minute step in it will produce audio-frequencies directly.

(d) A crystal cut at a slight angle to the electric axis will produce audio-frequencies directly.

(e) A crystal whose dimensions are such that a harmonic of one of the three possible fundamental oscillations beating with one of the other two fundamentals gives audio-frequencies directly.

In all cases it is to be noted that the percentage error in the beat frequency is as many times the error in one of the two high frequencies

as the beat frequency is contained in the average value of the two beating frequencies. This is an inherent disadvantage of the method.

Experiments carried on over a period of several years showed that the schemes under (a) and (c) are the most promising when audio-frequency standards are concerned. It has been found that a stepped crystal (c) with an air gap of about one-third of a millimeter between it and the electrode above it can be held constant in frequency to within a few parts in 100,000, provided the crystal remains fixed in position. If the crystal is moved around in the holder, its frequency may vary as much as one-tenth of 1 per cent.

II. CIRCUIT FOR AUDIO-FREQUENCIES

When using the system described under (a) it was found that the effect of the crystal holder was very pronounced. When an air gap was used it was found that the supersonic sound waves reacted back upon the crystal. In addition, the capacity due to the crystal holder had an effect on the frequency. The same is true when a condenser is employed across the inductance in the anode branch of the tube. The setting of the condenser changed the beat frequency especially when the impedance in the anode branch was close to current resonance. All these effects seem much more pronounced than the effect due to normal changes in the temperature, since the temperature effect on the beat frequency is about the same as on each of the two high frequencies because the physical dimensions of the two quartz plates are practically identical.

The arrangement of Figure 1 was finally adopted, and the complete apparatus is shown in Figure 2. It consists of two self-contained independent piezo-electric generators of frequencies f_1 and f_2 , respectively. The plate of each circuit is connected through a small air condenser of negligible leakance (special construction) to only one output terminal. The output terminals of the two generators are connected to a radio-frequency amplifier whose reaction is negligible, since a shield grid tube is employed. The audio-frequency current is taken off on the secondary terminals of the transformer in the detector circuit. Since the energy (power) taken away from the two high-frequency sources is very small, a variable condenser is provided across the input coil of the detector. By means of it a tuning to frequencies f_1 and f_2 is possible.

With this arrangement, using circular quartz disks which are sputtered on each side with platinum and whose upper contact (to grid) was made by means of a thin gold leaf pasted at a fixed place, an accuracy of a few parts in 100,000 is obtained.

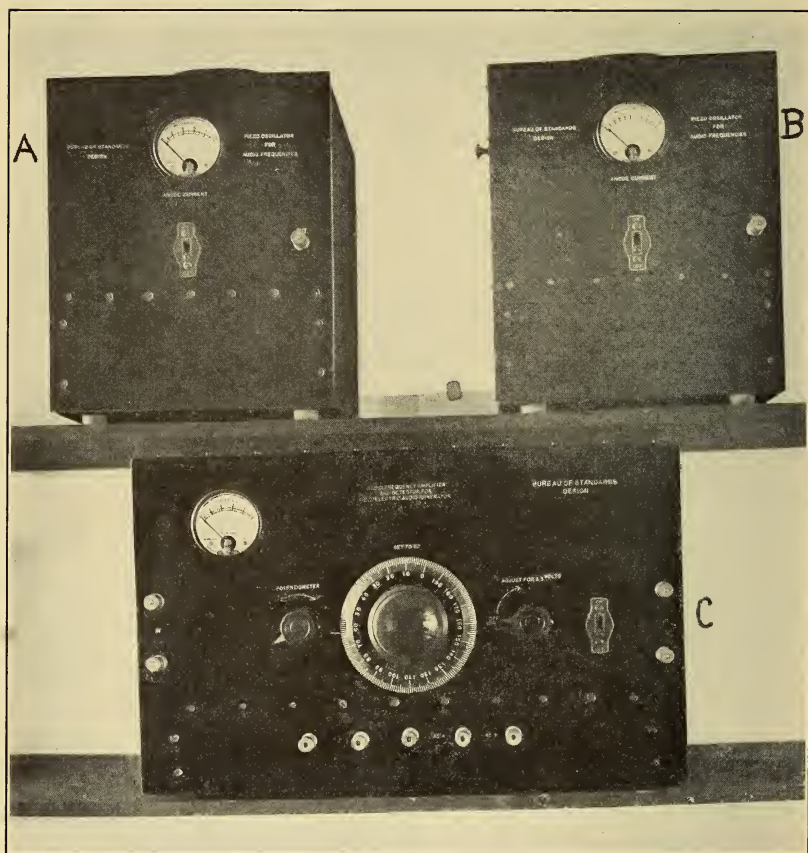

FIG. 2.—Laboratory apparatus corresponding to Figure 1

A, Piezo-oscillator of radio-frequency f_1

B, Piezo-oscillator of radio-frequency f_2

C, Radio-frequency amplifier and detector for producing the audio current of frequency f_1-f_2

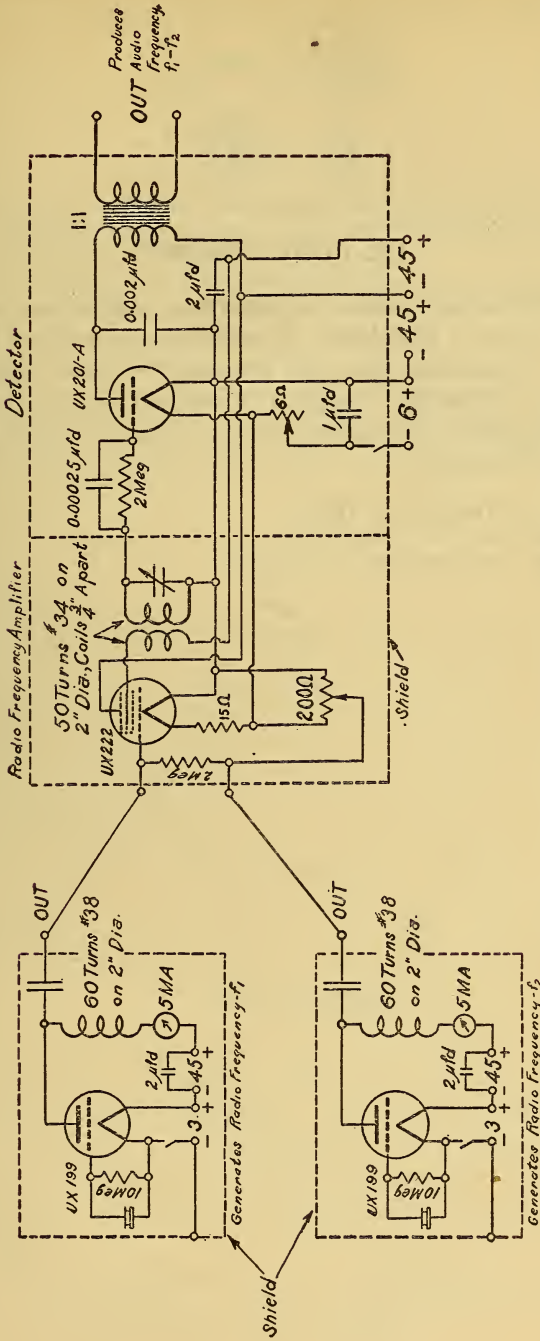

FIG. 1.—Diagram of connections for the beat oscillator

A typical test carried out on different days is as follows:

Temperature	Frequency
° C.	Cycles/sec.
24.5	1,242.026
24.5	1,242.088
24.5	1,242.1
25.0	1,242.124

III. CONCLUSIONS

An audio-frequency source is described which may serve as a secondary frequency standard. It seems to be as good as a tuning fork drive. It indicates that the frequency of each high frequency must be very stable and suggests a method which uses only one piezo-electric generator and produces the audible current by means of harmonic division.¹

WASHINGTON, October 5, 1928.

¹ Proc. I. R. E., 16, p. 1072; August, 1928.