

Library, N.W. side

Feb 28 1956

NBS CIRCULAR 568

Reference book not to be
taken from the Library.

High-Temperature Reactions of Uranium Dioxide With Various Metal Oxides

UNITED STATES DEPARTMENT OF COMMERCE

NATIONAL BUREAU OF STANDARDS

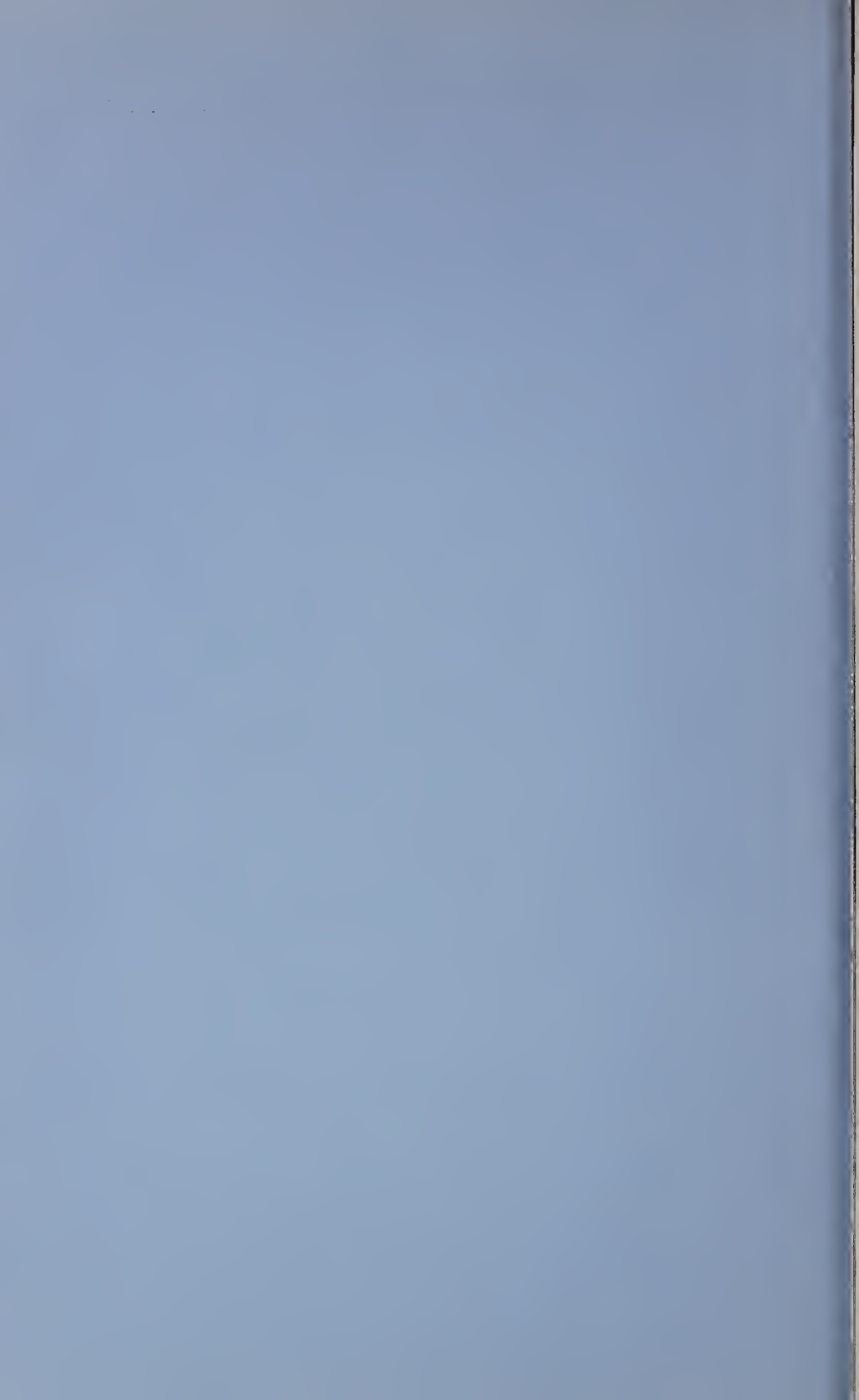

High-Temperature Reactions of Uranium Dioxide With Various Metal Oxides



National Bureau of Standards Circular 568

Issued February 20, 1956

For sale by the Superintendent of Documents, U. S. Government Printing Office

Washington 25, D. C. - Price 20 cents

Contents

| | Page |
|--|------|
| 1. Introduction | 1 |
| 2. The uranium-oxygen system..... | 1 |
| 3. Binary systems containing UO_2 | 5 |
| 3.1. UO_2 -MO systems..... | 5 |
| a. UO_2 -BeO..... | 5 |
| b. UO_2 -MgO..... | 6 |
| c. UO_2 -CaO..... | 7 |
| d. UO_2 -SrO..... | 12 |
| e. UO_2 -BaO..... | 13 |
| f. UO_2 -CuO..... | 14 |
| 3.2. UO_2 - M_2O_3 systems..... | 14 |
| a. UO_2 - Al_2O_3 | 14 |
| b. UO_2 - Y_2O_3 | 15 |
| c. UO_2 - Nd_2O_3 | 16 |
| 3.3. UO_2 - MO_2 systems..... | 17 |
| a. UO_2 - SiO_2 | 17 |
| b. UO_2 - ZrO_2 | 18 |
| c. UO_2 - SnO_2 | 19 |
| d. UO_2 - CeO_2 | 19 |
| e. UO_2 - ThO_2 | 21 |
| 3.4. UO_2 - M_2O_5 systems..... | 23 |
| a. UO_2 - V_2O_5 | 23 |
| 4. Summary..... | 24 |
| 5. Appendix..... | 25 |

HIGH-TEMPERATURE REACTIONS OF URANIUM DIOXIDE WITH VARIOUS METAL OXIDES¹

S. M. Lang, F. P. Knudsen, C. L. Fillmore, and R. S. Roth

The high-temperature reactions of UO_2 with 15 metal oxides are described, usually in the form of phase-equilibrium diagrams, from data determined at the National Bureau of Standards and from a survey of the available literature. The systems are discussed in groups according to the cation valence of the second oxide; the divalent oxides BeO , MgO , CaO , SrO , BaO , and CuO ; the trivalent oxides Al_2O_3 , Y_2O_3 , and Nd_2O_3 ; the tetravalent oxides SiO_2 , ZrO_2 , SnO_2 , CeO_2 , and ThO_2 ; and the pentavalent oxide V_2O_5 . A brief review is presented for the relations in the U-O system, particularly in the region of UO_2 . Detailed descriptions of the equipment and the procedures used for the National Bureau of Standards investigation are included in an appendix.

1. Introduction

Investigation of the high-temperature reactions of uranium and its compounds with a large variety of materials has been an important segment of the research activities of the U. S. Atomic Energy Commission and many of its contractors. As a part of these activities there was instituted, in the Porcelain and Pottery Section of the National Bureau of Standards, a project for the determination of the phase-equilibrium relations of binary systems containing UO_2 and various metal oxides. This paper is a report of those studies and also a review of the unclassified literature. There is no discussion of the reactions of various materials with any uranium oxide other than UO_2 .

For convenience, the 15 systems described are given in groups according to the cation valence of the second oxide. Detailed descriptions of the equipment and procedures used for the National Bureau of Standards investigation are included in an appendix.

2. The Uranium-Oxygen System

Because the results of many investigations showed that the reactions of uranium and oxygen are extremely complicated, a brief literature review of the uranium-oxygen system, particularly within the compositional region UO_2 to UO_3 , is presented. Considering first the system at low-oxygen content, Hart [1]² stated that he could not obtain any polished uranium-metal surfaces that were free of uranium oxides, regardless of the polishing technique employed. The oxides identified, and found to occur under similar conditions of reproducibility, were one or more of the following: UO_2 , U_2O_5 , and U_3O_8 . It was stated that the oxide films do not protect the uranium from further oxidation mainly because of the lack of coherence.

An excellent description of the oxidation of UO_2 is given by Katz and Rabinowitch [2], from whose book the data for figure 1 was taken. Since that time, other information [3] has become available. In addition, Hering and Perio [4] studied the low-temperature oxida-

¹ This project was sponsored by the U. S. Atomic Energy Commission.

² Figures in brackets indicate the literature references at the end of this paper.

high-temperature form of U_3O_8 but do show the formation of a hexagonal structure at temperatures above 400°C .

Early in the work of this project, the authors investigated the "oxidation" of UO_2 with respect to the preparation and storage of various UO_2 -metal oxide mixtures. Samples of the "as received" UO_2 (passed through a No. 325 U. S. Standard Sieve) were maintained at 113°C for periods up to 4,000 hours in both a laboratory atmosphere and in air that had been dried over magnesium perchlorate. Figure 4 shows the results of these weight-gain determinations.

The pronounced effect of atmospheric water vapor led to a cursory study of the effect of temperature on the "oxidation" of UO_2 . A series of samples was heated in the laboratory atmosphere at 400° , 600° , 800° , $1,000^\circ$, $1,200^\circ$, and $1,400^\circ\text{C}$ for periods of 1, 3, 5, and 7 hours, and quenched. For each of the time intervals, the maximum weight gain (about 3.6%) occurred at the $1,000^\circ$ or $1,200^\circ\text{C}$ heat treatments, and at these temperatures there was no further change in weight after the first hour. Those samples heated above $1,200^\circ\text{C}$ and below $1,000^\circ\text{C}$ showed a progressively lower weight gain as the time at a given temperature was increased from 1 to 7 hours. Although the role of water vapor is not known, it would seem that, for the lower-temperature tests, hydration, oxidation, and dehydration were occurring at different rates. The large decrease in weight gain with extended heating (from about 3.5% after 1 hour to 2.0% after 7 hours) for those samples maintained at $1,400^\circ\text{C}$ was indicative of the dissociation of the higher-uranium oxides to form a UO_2 -like material even in the presence of oxygen [2]. The possibility exists that UO_2 may undergo vapor transfer as a hydrate, similar to that known to occur for BeO in the presence of water vapor [10].

Whether the atmospheric water vapor was absorbed, whether it formed a UO_2 -hydrate, or whether it catalyzed the oxidation process was not determined. However, these studies indicated that small amounts of water vapor, which might be present, should be removed from the neutral atmospheres employed in the phase studies of the various UO_2 systems. A description of the atmosphere train used is given in the appendix.

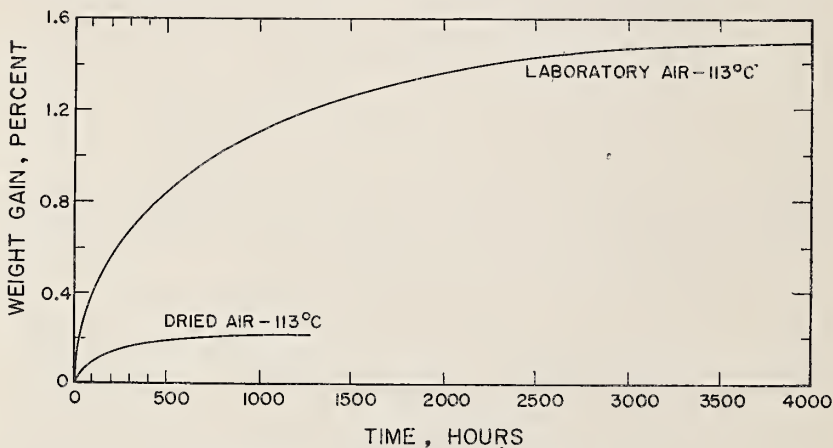

FIGURE 4. *Weight gain of UO_2 at 113°C .*

Dried air was obtained by passing laboratory air through magnesium perchlorate.

In summarizing these reports, the uranium-oxygen system may be characterized by the following: (a) Rapid oxidation of mixtures usually containing less oxygen than that in U_3O_8 , even at low temperatures; (b) reduction of oxides such as U_2O_5 , U_3O_8 , and UO_3 at temperatures above $1,450^\circ\text{C}$ to a UO_2 -like structure, even when heated in the presence of oxygen; (c) a multiplicity of crystalline forms, especially for UO_3 , and their numerous hydrates; (d) extensive solid solutions in the system with both reversible and irreversible decomposition; (e) the metastability of portions of solid solutions that have been reported as compounds, the existence of which has been questioned; and (f) the dependence of these characteristics on the original material-formation method and the subsequent thermal and atmospheric history.

3. Binary Systems Containing UO_2

3.1. UO_2 -MO Systems

a. UO_2 -BeO (Fig. 5)

Because no solid-solution or compound formation was found to occur between 800° and $1,800^\circ\text{C}$ within the compositional range 10 to 90 mole percent of BeO, the objective of the high-temperature study was limited to the determination of the liquidus curve in the region of the eutectic composition. The eutectic of the UO_2 -BeO system was found to be located at 63 ± 2 mole percent of BeO and $2,150^\circ \pm 10^\circ\text{C}$. The melting point of BeO was determined as $2,450^\circ \pm 20^\circ\text{C}$ (appendix, see table 5).

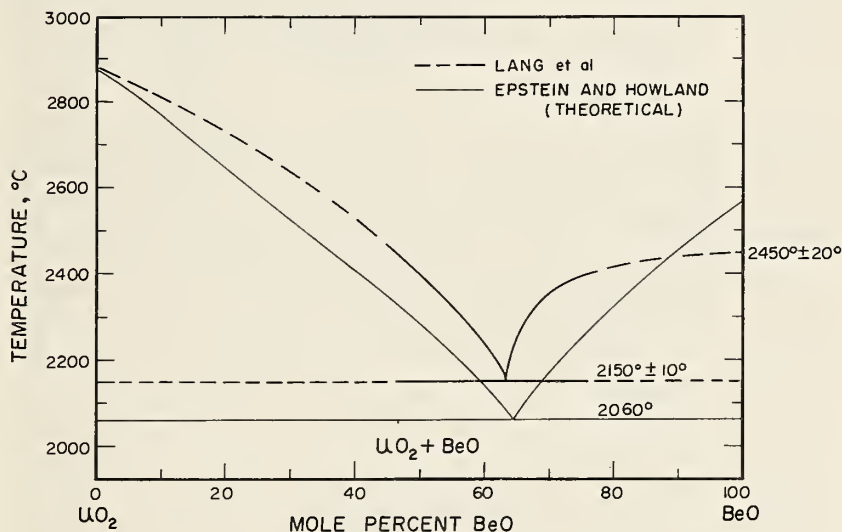

FIGURE 5. The system UO_2 -BeO.

The authors found that no compound or solid-solution formations occurred at temperatures from 800° to $1,800^\circ\text{C}$ within the compositional range 10 to 90 mole percent of BeO. See also L. F. Epstein and W. H. Howland, Binary mixtures of UO_2 and other oxides, *J. Am. Ceram. Soc.* **36**, 334 (1953).

Epstein and Howland [11] determined the theoretical eutectics of three UO_2 systems, using ideal solution laws. Their calculated values for the temperatures and compositions of the various eutectics are

| System | Eutectic composition | Eutectic temperature |
|---|----------------------------|---------------------------|
| $\text{UO}_2\text{-Al}_2\text{O}_3$ ----- | Mole % UO_2 26 | $^\circ\text{C}$ 1,900 |
| $\text{UO}_2\text{-BeO}$ ----- | 35 | 2,060 |
| $\text{UO}_2\text{-MgO}$ ----- | 41 | 2,159 |

b. $\text{UO}_2\text{-MgO}$ (Fig. 6)

An experimental investigation of the liquidus temperatures of the system $\text{UO}_2\text{-MgO}$ was carried out by Lambertson and Mueller [12]. They reported the eutectic at about $2,100^\circ\text{C}$ and about 75 mole percent of MgO , and another invariant point at about $2,220^\circ\text{C}$ and about 32 mole percent of MgO . A region of two-liquid immiscibility is shown at about $2,220^\circ\text{C}$ within the approximate range 32 to 68 mole percent of MgO . When UO_2 is diluted with MgO and when MgO is diluted with UO_2 , the curvature of the liquidus line departs from that of a theoretical dilution line. This is attributed to probable dissociation of small amounts of UO_2 and MgO . The deviation of the system from a true binary system is shown, and the dissociation of MgO as a function of temperature is discussed. It is stated that oxygen acts as a third component and probably has some influence

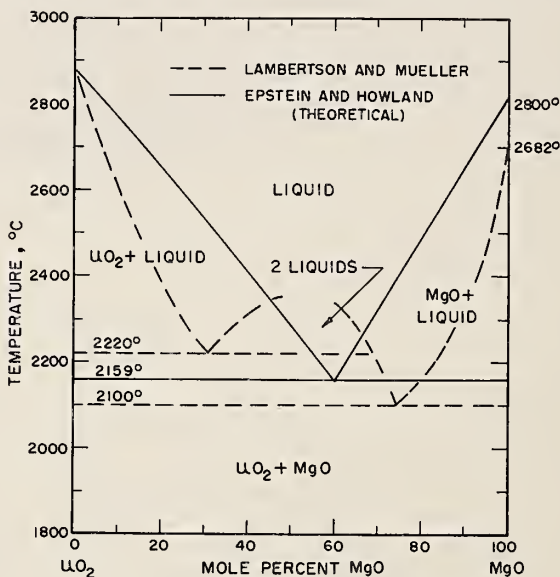

FIGURE 6. The system $\text{UO}_2\text{-MgO}$.

The authors found that no compound or solid-solution formations occurred at temperatures from 400° to $1,800^\circ\text{C}$ within the compositional range 20 to 98 mole percent of MgO . See also, W. A. Lambertson and M. H. Mueller, Uranium oxide phase equilibrium systems: II, $\text{UO}_2\text{-MgO}$, *J. Am. Ceram. Soc.* **36**, 332 (1953); L. F. Epstein and W. H. Howland, Binary mixtures of UO_2 and other oxides, **36**, 334 (1953).

on the liquidus. The melting point of MgO is given as about 2,680° C, in contrast to the literature value of 2,800° C, but it is shown that dissociation of 4 percent of MgO could account for the lower temperature when determined in an oxygen-free helium atmosphere. The theoretical determination of Epstein and Howland [11], using ideal thermodynamic solution laws, gives the eutectic of this system at 2,159° C and 41 mole percent of UO₂.

No evidence of compound formation at any temperature between 300° and 2,350° C was found by Anderson and Johnson [13] in their study of the UO₂-MgO system. However, they do show that at very high temperatures a few moles of MgO enter into a cubic, fluorite-type, UO₂ solid solution with anion vacancies. They state that this defective solution-structure has a great affinity for oxygen, thereby increasing the solubility of MgO in the UO₂ solution to as much as 25 mole percent. In addition, they show by experimental data that, in the UO₂-MgO-O system, the lattice-constant changes occurring in UO₂ are caused mainly by the solubility of MgO in the defective UO₂ solid-solution structure, and only in part by UO₂ oxidation. However, they state that the accuracy of their analytical method would be greatly reduced if wide variation of oxygen content occurred independently.

The present study showed that there were no compound or solid-solution formations at temperatures from 400° to 1,800° C within the compositional range 20 to 98 mole percent of MgO. When samples of mixtures within this range were heated at temperatures of 2,000° C or higher (in the atmosphere-controlled melting-point furnace), the volatilization and condensation of MgO was so great as to almost instantaneously cover the viewing port. In addition, a slight oxidation of the UO₂ in these UO₂-MgO mixtures heated above 2,000° C indicated that there was some dissociation of MgO. Although a number of furnace modifications were made in an attempt to overcome these difficulties, no satisfactory answer was found.

c. UO₂-CaO (Fig. 7)

Alberman, Blakey, and Anderson [14] presented a comprehensive study of the UO₂-CaO system in the temperature range from about 1,500° to 2,300° C. The eutectic was determined as being at 2,080° ± 20° C and about 55 mole percent of CaO. It was determined from X-ray diffraction data that CaO takes no detectable amount of UO₂ into solid solution, but that UO₂ forms an extensive cubic solid solution with defective fluorite structure. At the eutectic temperature, this solid solution contains 47 mole percent of CaO. The concentration of the CaO-saturated solid solution decreases with decreasing temperature, so that (1) at the solid-state invariant point at 1,950° C, the cubic solid solution contains 43 mole percent of CaO, and (2) at about 1,650° C the concentration is only about 20 mole percent of CaO. Below 1,750° C, the formation of two compounds is reported: cubic CaUO₃, a Type-C rare-earth oxide structure; and, tetragonal Ca₂UO₄, structure unknown.³ The decomposition of these compounds is said to occur at some temperature between 1,750° and 1,950° C. Samples for the study were heated in a vacuum in tantalum containers, and it is stated: "With the occurrence of eutectic melting,

³ The lattice constant reported for cubic CaUO₃ is given in both kX and angstrom units as 10.727 ± 0.002 and for tetragonal Ca₂UO₄ it is given, also, in both kX and angstrom units as $a = 16.760$ and $c = 9.208$ ($c/a = 0.549$).

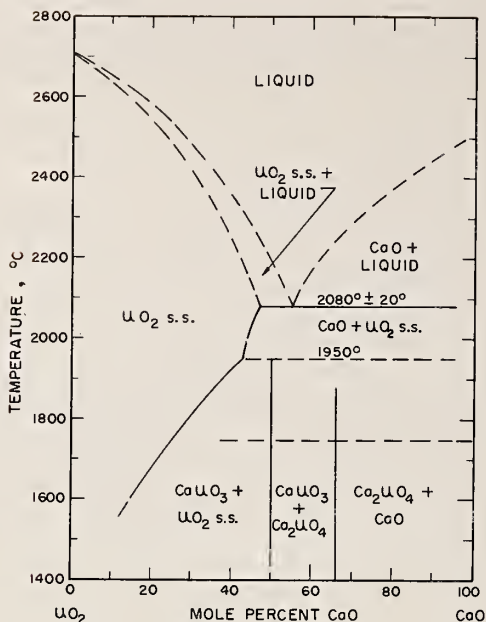

FIGURE 7. *The system UO₂-CaO, according to Alberman, et al.*

K. B. Alberman, R. C. Blakey, and J. S. Anderson, *The oxides of uranium, Part II: The binary system UO₂-CaO*, *J. Chem. Soc.* p. 1352, 1951.

reaction (with the tantalum crucibles) was rapid, and the interior of the bell-jar was covered with condensed calcium; in these circumstances, as much as 14 percent of tantalum dioxide was found in the melt after complete fusion. Eutectic temperatures were, however, taken from the first signs of melting, and it is believed that no considerable errors were introduced from this source."

The present study of compound formations in this system (along with those in the other alkaline-earth oxide systems, UO₂-SrO and UO₂-BaO) was initiated when attempts were made to synthesize the compounds according to the procedure described by Alberman, et al. Mixtures containing about 20, 62, and 83 mole percent of CaO were heated at 1,700° and at 1,800° C in an argon atmosphere and furnace-cooled as rapidly as possible. Examination of the X-ray patterns of these mixtures revealed that the structures proposed by Alberman should not be ascribed to the compounds formed.

After heating the 20-mole-percent-CaO mixture at 1,700° C for 1 hour, it showed only the reported cubic UO₂ solid-solution phase; the lattice constant was determined to be 5.428 Å. Examination of the X-ray pattern, table 1, for the 62-mole-percent-CaO mixture heated at 1,800° C shows that it is a mixture of two phases. A cubic-fluorite-type, solid-solution phase ($a = 5.418$ Å) is predominant. The other phase is present as a small amount of an orthorhombic, 1:1 perovskite-type compound. It is believed that this two-phase formation is more likely than the reported rare-earth, Type C, structure proposed by Alberman et al. for CaUO₃ because there are too many large discrepancies between the calculated and the observed "d" values given in their report.

TABLE 1. X-ray diffraction data for a 62-mole-percent-CaO mixture in the UO_2 -CaO system

| NBS data | | | | Alberman data for $CaUO_3$ | |
|----------|-----------------------------|----------|-------------------------|----------------------------|------------|
| <i>d</i> | UO_2 cubic solid solution | | Perovskite ^a | <i>d</i> | <i>hkl</i> |
| | <i>hkl</i> | <i>a</i> | <i>hkl</i> | | |
| <i>A</i> | | <i>A</i> | | <i>A</i> | |
| 4.2 | | | 101 | 4.831 | (b) |
| 3.12 | 111 | 5.40 | | 4.158 | 211 or (b) |
| 2.94 | | | 121 | 3.112 | 222 |
| 2.70 | 200 | 5.40 | | 2.948 | (b) |
| | | | | 2.689 | 400 |
| | | | | 2.499 | 411, 330 |
| | | | | 2.430 | (b) |
| | | | | 2.370 | 420 |
| 2.08 | | | 202 | 2.078 | 431, 510 |
| 1.913 | 220 | 5.409 | | 1.902 | 440 |
| | | | | | |
| 1.860 | | | 141 | 1.863 | 433, 530 |
| 1.695 | | | 240, 321 | 1.712 | 532, 611 |
| | | | | 1.677 | 602 |
| 1.631 | 311 | 5.409 | | 1.617 | 622 |
| | | | | 1.572 | 631 |
| | | | | | |
| 1.562 | 222 | 5.410 | | | |
| | | | | 1.547 | 444 |
| | | | | 1.490 | 640 |
| 1.470 | | | 242, 014 | | |
| | | | | 1.443 | 721, 633 |
| | | | | 1.403 | 730 |
| 1.353 | 400 | 5.412 | | | |
| 1.317 | | | ? | 1.316 | 811, 741 |
| | | | | 1.261 | 822, 660 |
| 1.243 | 331 | 5.417 | | 1.230 | 662 |
| | | | | | |
| 1.210 | 420 | 5.413 | | 1.211 | 752 |
| | | | | 1.199 | 840 |
| | | | | 1.170 | 842 |
| | | | | 1.152 | 921, 761 |
| | | | | 1.117 | 930, 932 |
| | | | | | |
| 1.106 | 422 | 5.416 | | 1.094 | 844 |
| 1.042 | 511, 333 | 5.415 | | 1.033 | 1022, 666 |
| | | | | 1.016 | 1031, 952 |
| | | | | 0.9958 | 1040, 864 |
| | | | | .9816 | 1033, 961 |
| | | | | | |
| .9573 | 440 | 5.415 | | .9690 | 1110, 954 |
| | | | | .9583 | 1121, 1051 |
| | | | | .9493 | 880 |
| | | | | .9388 | 970, 1130 |
| .9161 | 531 | 5.419 | | .9162 | 1060, 866 |
| | | | | | |
| .9019 | 600, 442 | (5.411) | | .9069 | 1062 |
| | | | | .8940 | 1200, 884 |
| .8571 | 620 | 5.420 | | .8569 | 1073 |
| | | | | .8465 | 1240 |
| .8264 | 533 | 5.419 | | .8277 | 1082 |
| | | | | | |
| .8168 | 622 | 5.418 | | .8190 | 1066 |
| | | | | | |
| | | | | .8001 | 1244 |
| | | | | .8035 | 1330, 994 |
| | | | | .7822 | 1341, 1174 |
| | | | | | |
| | | | | .7785 | 1093 |
| | | | | | |
| | <i>a</i> =5.418 Å | | | <i>a</i> =10.727 Å | |

^a Orthorhombic, probably $Ca(U, Ca)O_2$, see table 2.

^b Alberman et al attribute these lines to tetragonal Ca_2UO_4 .

The X-ray diffraction pattern for the 83-mole-percent-CaO mixture after heating at 1,700° C for 1 hour agrees with Alberman's data. Both Alberman et al. and the authors found that the compound could not be formed from stoichiometric mixtures of the component oxides, but that it could be formed only when a considerable excess of CaO is present. All of the diffraction lines listed by Alberman et al. for "tetragonal Ca₂UO₄" plus some weak lines for CaO and CaO·xH₂O (probably CaO·H₂O) appear in this pattern, table 2. When this pattern is compared with those for CaTiO₃ and CaSnO₃, it is seen to be isostructural with them and represents an orthorhombic, 1:1 perovskite-type compound, which could be CaUO₃. However, the existence of the perovskite structure would suggest that the single phase obtained would more properly be Ca(U,Ca)O_x. The 2:1 structure proposed by Alberman et al. seems difficult to substantiate, in view of their reported chemical analysis.

The perovskite structure may be indexed on an orthorhombic basis [15] even though the first two peaks at 4.8₄ Å and 4.7₃ Å, which are shown in both the author's and the Alberman diffraction patterns, do not appear in the CaTiO₃ patterns. Indexing in this manner results in the following parameters: $a=5.78 \approx \sqrt{2}$ times the pseudo-cube; $b=8.29 \text{ Å} \approx 2$ times the pseudo-cube; and, $c=5.97 \text{ Å} \approx \sqrt{2}$ times the pseudo-cube. The presence of the two extra peaks

TABLE 2. X-ray diffraction data of an orthorhombic, perovskite-type, UO₂-CaO compound^a

| NBS data | | Alberman data | | NBS data | | Alberman data | |
|-----------------------|-----------------------|---------------------|--|-----------------------|-----------------------|-----------------------|--|
| Orthorhombic <i>d</i> | Perovskite <i>hkl</i> | Tetragonal <i>d</i> | Ca ₂ UO ₄ <i>hkl</i> | Orthorhombic <i>d</i> | Perovskite <i>hkl</i> | Tetragonal <i>d</i> | Ca ₂ UO ₄ <i>hkl</i> |
| 4.8 | 011 | 4.809 | 301 | 1.555 | (e) | ----- | ----- |
| 4.7 | 110 | 4.688 | 320 | 1.492 | 004 | 1.498 | 1101, 545 |
| 4.1 | 101 | 4.134 | 321, 400 | 1.473 | 242 | 1.475 | 880 |
| 3.10 | (b) | ----- | ----- | 1.468 | 014 | ----- | ----- |
| 2.98 | 002 | 2.989 | 332 | 1.446 | 400 | 1.452 | 705, 326 |
| 2.94 | 121 | 2.943 | 440 | 1.406 | 024 | 1.403 | 882 |
| 2.88 | 200 | 2.871 | 530, 203 | ----- | ----- | 1.386 | 516 |
| 2.78 | (c) | ----- | ----- | ----- | ----- | 1.328 | 1212, 883 |
| 2.62 | (c) | ----- | ----- | ----- | ----- | 1.319 | 1240 |
| 2.53 | 201 | 2.529 | 621 | ----- | ----- | 1.305 | 1080, 905 |
| 2.48 | 211 | 2.480 | 630, 442 | ----- | ----- | 1.288 | 925, 706 |
| 2.43 | 022 | 2.429 | 552 | ----- | ----- | 1.268 | 1242, 1171 |
| 2.40 | (c) | ----- | ----- | ----- | ----- | 1.245 | 1260, 945 |
| 2.37 | 220 | 2.375 | 602 | ----- | ----- | 1.220 | 826, 807 |
| 2.08 | 202 | 2.081 | 800 | ----- | ----- | 1.179 | 1224 |
| 2.07 | 040 | ----- | ----- | ----- | ----- | 1.160 | 1055 |
| 1.919 | (c) | ----- | ----- | ----- | ----- | 1.148 | 008, 1440 |
| 1.881 | 103 | 1.897 | 802 | ----- | ----- | 1.133 | 776 |
| 1.859 | 141 | 1.866 | 840 | ----- | ----- | 1.123 | 1371 |
| 1.830 | 301 | 1.843 | 524 | ----- | ----- | 1.099 | 1372 |
| 1.791 | (c) | ----- | ----- | ----- | ----- | ----- | ----- |
| 1.714 | 122 | 1.723 | 803, 544 | $a=5.78 \text{ Å}$ | ----- | $a=16.760 \text{ Å}$ | ----- |
| 1.709 | 042 | ----- | ----- | $b=8.29 \text{ Å}$ | ----- | $c=9.208 \text{ Å}$ | ----- |
| 1.699 | 240 | ----- | ----- | $c=5.97 \text{ Å}$ | ----- | $c/a=0.549 \text{ Å}$ | ----- |
| 1.693 | 321 | 1.683 | 770 | ----- | ----- | ----- | ----- |
| 1.676 | (c) | ----- | ----- | ----- | ----- | ----- | ----- |
| ----- | ----- | 1.615 | 724 | ----- | ----- | ----- | ----- |
| ----- | ----- | 1.595 | 951, 843 | ----- | ----- | ----- | ----- |

^a Orthorhombic, probably Ca(U,Ca)O₂.

^b This line is due to the UO₂ solid-solution phase.

^c These lines are due to either CaO or CaO·H₂O.

(4.8₄ and 4.7₃ Å) at low-diffraction angles may be due to the much heavier U⁴⁺ ions, causing stronger X-ray scattering along certain sets of planes than do the Ti⁴⁺ and Sn⁴⁺ ions.

Because the interpretations of these data could not be reconciled with the interpretations presented by Alberman et al. [14] an attempt was made to attain the equilibrium conditions described by them. Samples of 25, 33½, 50, 66½, and 75 mole percent of CaO, preheated at 1,800° C, were reheated at 1,500° C for 360 hours in a purified-helium atmosphere and cooled rapidly. At the same time, a number of preheated mixtures in the UO₂-SrO and UO₂-BaO systems were reheated (sections 3.1.d and 3.1.e). To insure against extraneous oxygen being present, the samples were sealed into capsules made from seamless platinum tubing. These capsules were evacuated and helium filled, repeatedly, and then sealed, using a carbon arc, in a helium-filled atmosphere. Tantalum "wool" was placed around the capsules after they had been loaded in a platinum basket. After heating and rapidly cooling the capsule, it was noted that no apparent oxidation of the tantalum wool had occurred, and there was no evidence of any opening in the capsules, although all were bloated. When the specimens were examined after the heat treatment, various amounts of oxidation occurred. In the 75-mole-percent-CaO mixture, the orthorhombic, perovskite-type compound, Ca(U,Ca)O₂, predominated, and a slight amount of a phase, the lattice constants of which agree with those published for CaUO₄, was present. As the amount of alkaline-earth oxide was reduced, the amount of oxidation increased, so that the 50-mole-percent-CaO mixture showed only the formation of the completely oxidized CaUO₄ compound. However, a further reduction in the alkaline-earth content also reduced the amount of oxidation, so that the 25-mole-percent-CaO mixture showed only the cubic, fluorite type, UO₂ solid-solution phase. To establish whether the oxidation was complete after the longtime test at 1,500° C in helium, the 1:1 mixture was reheated in air at 1,350° C for 4 hours, and cooled rapidly. The air heating caused no change in the X-ray diffraction pattern, although the sample did change color from gray-green to bright yellow.

The oxidation process in these mixtures seems to be considerably more complicated than can be expressed in terms of an oxygen-contaminated atmosphere. The coincidence of maximum oxidation in the equimolar mixtures of CaO, BaO, or SrO with UO₂ cannot be reconciled with the absence of oxidation in the end-member mixtures of each series studied. In addition, the valence change, indicated by the color change but without crystallographic change, which occurred when the equimolar mixtures were reheated in air, complicates the reasoning that may be applied to the processes involved.

Although not investigated, any one or more of the following possibilities might have been responsible for the phenomena observed, even if the atmosphere were as oxygen free as it was believed to have been: (a) the presence and subsequent decomposition of water vapor that may have been adsorbed during or after the presintering treatment; (b) the reduction in the neutral atmosphere of CaO in the high-lime mixtures, and the oxidation of Ca on exposure to air; (c) a possible solid solution of CaUO₃ with CaUO₄; and, (d) the formation of a high-temperature, oxygen-deficient CaUO₄ structure, which completely oxidized during the air heat treatment.

It would seem from the present study and that of Alberman, Blakey, and Anderson [14] that considerable work must be done to gain an understanding of the equilibria that exists at temperatures below about 1,950° C.

d. $\text{UO}_2\text{-SrO}$

Mixtures in the $\text{UO}_2\text{-SrO}$ system containing 25, 33 $\frac{1}{3}$ %, 50, 66 $\frac{2}{3}$ %, and 75 mole percent of SrO were heated at 1,800° and at 1,900° C for $\frac{1}{2}$ hour in an argon atmosphere. X-ray diffraction examination of the samples after heating indicated that the $\text{UO}_2\text{-SrO}$ system is analogous to the $\text{UO}_2\text{-CaO}$ system.

The 25-mole-percent-SrO mixture contained only a cubic, fluorite-type, UO_2 solid-solution phase. Mixtures containing 33 $\frac{1}{3}$ % and 50 mole percent of SrO showed two phases: (1) the fluorite-type, cubic solid solution, and (2) an orthorhombic, perovskite-type compound, isostructural with $\text{Ca}(\text{U,Ca})\text{O}_z$. The 50-mole-percent-SrO mixture could not be heated to produce a single phase even after having been maintained for 4 hours at 1,800° C, although there was relatively much more of the $\text{Sr}(\text{U,Sr})\text{O}_z$ phase than there was of the similar $\text{Ca}(\text{Ca,U})\text{O}_z$ phase in the 63-mole-percent-CaO mixture of the $\text{UO}_2\text{-CaO}$ system. Evidently, the tendency for formation of this type of compound increases with increasing ionic radius of the alkaline-earth ions. X-ray diffraction patterns of those mixtures containing more than 50 mole percent of SrO show the two diffraction lines at 5.0 \AA and 4.9 \AA , analogous to those found in the $\text{UO}_2\text{-CaO}$ mixtures. These lines also probably belong to the perovskite compound. Diffraction data for $\text{Sr}(\text{U,Sr})\text{O}_z$, from the pattern of the 66 $\frac{2}{3}$ -mole-percent-SrO mixture, are given in table 3. The pattern is indexed on the basis of an orthorhombic cell [15] with $a=6.01 \approx \sqrt{2}$ times the pseudo-cube; $b=8.60 \approx 2$ times the pseudo-cube; and $c=6.17 \approx \sqrt{2}$ times the pseudo-cube.

As with the mixtures of the $\text{UO}_2\text{-CaO}$ system, those of the $\text{UO}_2\text{-SrO}$ system that had been heated at 1,800° C. in an argon atmosphere

TABLE 3. X-ray diffraction data for an orthorhombic, perovskite-type, $\text{UO}_2\text{-SrO}$ compound ^a

| <i>d</i> | <i>hkl</i> | <i>d</i> | <i>hkl</i> |
|----------|------------|---|------------|
| <i>A</i> | | <i>A</i> | |
| 5.0 | 011 | 1.922 | 141 |
| 4.9 | 110 | 1.902 | 113 |
| 4.3 | 101 | 1.771 | 123 |
| 3.85 | 111 | 1.762 | 042 |
| 3.08 | 002 | 1.747 | 240 |
| 3.03 | 121 | 1.742 | 321 |
| 3.00 | 220 | 1.543 | 004 |
| 2.61 | 102 | 1.520 | 242 |
| 2.58 | 201 | 1.503 | 400 |
| 2.50 | 112 | 1.440 | 143 |
| 2.46 | 211 | 1.373 | 204 |
| 2.38 | 131 | 1.361 | 323 |
| 2.15 | 202,040 | 1.359 | 161 |
| 1.945 | 222 | 1.351 | 402 |
| | | <i>a</i> =6.01 \AA . <i>b</i> =8.60 \AA . <i>c</i> =6.17 \AA . | |

^a Probably $\text{Sr}(\text{U,Sr})\text{O}_z$.

were reheated at 1,500° C for 360 hours in a helium atmosphere. The results were analogous to those discussed for the UO₂-CaO system, namely, (a) the 50-mole-percent-SrO mixture was completely oxidized to form only the SrUO₄ compound, whereas each of the end members of the series studied showed an absence of any oxidation, and (b) reheating the completely oxidized, helium-treated, 1:1 mixture in air at 1,350° C for 4 hours caused no change in the X-ray diffraction pattern, although the sample changed color from olive to bright orange.

e. UO₂-BaO

Mixtures in the UO₂-BaO system containing 25, 33½, 50, 66%, and 75 mole percent of BaO were heated at both 1,800° and at 1,900° C for ½ hour in an argon atmosphere. Examinations of the X-ray diffraction patterns of the samples were sufficient to establish that, in general, the UO₂-BaO system is similar to the UO₂-CaO and UO₂-SrO systems.

Some BaO, probably 20 to 30 mole percent, is accepted into the cubic UO₂ solid-solution structure; i. e., the 25-mole-percent-BaO mixture contained only the cubic UO₂ solid solution, whereas the 33½-mole-percent-BaO material was a mixture of cubic UO₂ solid solution and a perovskite-type compound. However, the compound is pseudo-cubic (probably BaUO₃), table 4, resembling BaCeO₃ but not clearly cubic like BaZrO₃, and not orthorhombic, like the Ca(U,Ca)O_z and the Sr(U,Sr)O_z compounds. Apparently, some BaO is accepted into the pseudo-cubic structure because the lattice constants of the compound in the 50- and 66%-mole-percent-BaO mixtures are different (by 0.04 Å). There is no evidence of such lattice-constant variations for the compounds in either the UO₂-CaO or the UO₂-SrO systems. The 66%-mole-percent-BaO mixture is a one-phase, cubic-perovskite solid solution, whereas the 75-mole-percent-BaO mixture contains excess BaO, as evidenced by the rapid deterioration of the sample when exposed to air.

The samples heated at 1,800° C were reheated at 1,500° C for 360 hours in a helium atmosphere. As was the case in the UO₂-CaO and UO₂-SrO systems, the maximum oxidation occurred in the 50-mole-percent-BaO mixture. However, neither pseudo-cubic BaUO₃ nor BaUO₄ could be identified by the X-ray diffraction examination. The 50-mole-percent-BaO sample, therefore, was reheated at 1,350° C for 4 hours in an air atmosphere. It is believed that this mixture had formed BaUO₄ during the air heating, although the compound could not be positively identified by comparison with X-ray diffraction patterns for BaUO₄ published in the literature.

TABLE 4. X-ray diffraction data for a pseudo-cubic UO₂-BaO compound, probably BaUO₃

| <i>d</i> | <i>hkl</i> | <i>a</i> | <i>d</i> | <i>hkl</i> | <i>a</i> |
|----------|------------|----------|----------|------------|-------------------------------|
| <i>A</i> | | <i>A</i> | <i>A</i> | | <i>A</i> |
| 4.4 | 100 | 4.4 | 1.034 | 330, 411 | 4.386 |
| 3.10 | 110 | 4.38 | 0.9812 | 420 | 4.387 _s |
| 2.19 | 200 | 4.38 | 0.9361 | 332 | 4.390 _o |
| 1.959 | 210 | 4.381 | 0.8951 | 422 | 4.385 ₂ |
| 1.790 | 211 | 4.384 | 0.8603 | 510, 431 | 4.386 ₅ |
| 1.550 | 220 | 4.384 | (0.8451) | (511, 333) | (4.3911) |
| 1.386 | 310 | 4.384 | 0.8009 | 521 | 4.386 _s |
| 1.266 | 222 | 4.386 | | | |
| 1.172 | 321 | 4.384 | | | <i>a</i> =4.3874 ₁ |

f. $\text{UO}_2\text{-CuO}$

A number of $\text{UO}_2\text{-CuO}$ mixtures, prepared at 10-mole-percent intervals, were heated in purified helium for 24 hours both at 700° and at 900° C. X-ray diffraction examination of mixtures heated at 700° C showed that each consisted of UO_2 and CuO . Samples of CuO and of UO_2 heated alone remained as such. Examination of the patterns for the mixture heated at 900° C revealed that the urania apparently had reduced practically all of the CuO to form a small amount of metallic copper and Cu_2O . At the same time, the urania had oxidized to some higher form. The UO_2 sample remained as such, but the CuO sample was almost entirely reduced to Cu_2O . It seemed, then, that further investigation of the system would be inappropriate and that, in the U-Cu-O system, $\text{UO}_2\text{-CuO}$ is not a binary join but that $\text{UO}_2\text{-Cu}_2\text{O}$ could be.

In order to determine whether the reduced copper oxide is compatible with UO_2 at some temperature less than 900° C, a few mixtures, prepared at 20-mole-percent intervals, were heated at 700° C for 6 hours. It was found, by X-ray diffraction examination, that the Cu_2O was being reduced by the urania, which, in turn, was being oxidized. The UO_2 sample remained as such during this treatment, and the Cu_2O sample was essentially the same, except that it contained slightly more metallic copper than it did before heating. These results eliminated any copper oxide-uranium dioxide systems from further consideration.

3.2. $\text{UO}_2\text{-M}_2\text{O}_3$ Systems

a. $\text{UO}_2\text{-Al}_2\text{O}_3$ (Fig. 8)

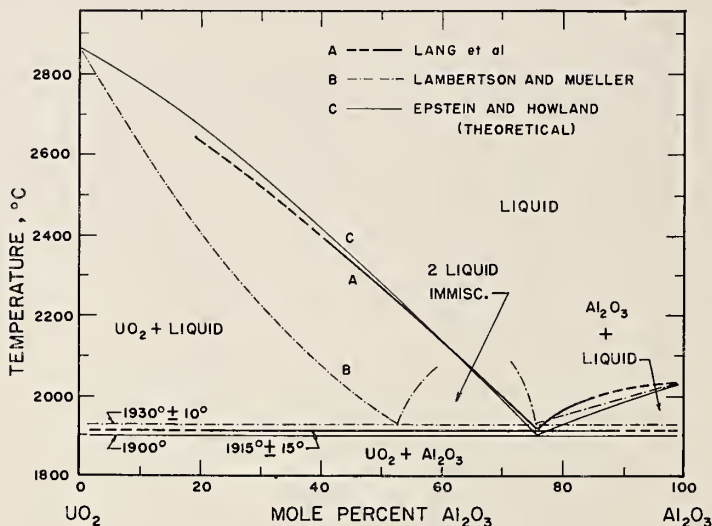

FIGURE 8. *The system $\text{UO}_2\text{-Al}_2\text{O}_3$.*

The authors found that no compound or solid-solution formations occurred at temperatures from 800° to $1,800^\circ$ C in the compositional range 10 to 90 mole percent of Al_2O_3 . See also, W. A. Lambertson and M. H. Mueller, Uranium oxide phase equilibrium systems: I, $\text{UO}_2\text{-Al}_2\text{O}_3$, *J. Am. Ceram. Soc.* **36**, 329 (1953); L. F. Epstein and W. H. Howland, Binary mixtures of UO_2 and other oxides, **36**, 334 (1953).

Lambertson and Mueller [16], in their description of the system $\text{UO}_2\text{-Al}_2\text{O}_3$, show that the curvature of the liquidus line departing from that of a theoretical dilution line when UO_2 is diluted with Al_2O_3 . They explain this as due to probable dissociation of a small amount of UO_2 . A region of two-liquid immiscibility is said to exist between about 54 and 75 mole percent of Al_2O_3 at $1,930^\circ \pm 10^\circ \text{C}$. The melting point of UO_2 was determined as being at $2,878^\circ \pm 22^\circ \text{C}$ and that of Al_2O_3 as being at $2,034^\circ \pm 16^\circ \text{C}$. The theoretical determinations of Epstein and Howland [11], using ideal thermodynamic solution laws, showed the eutectic of this system to be located at 26 mole percent of UO_2 and $1,900^\circ \text{C}$.

Equilibrium relations in the $\text{UO}_2\text{-Al}_2\text{O}_3$ system as determined by the authors were in very close agreement, especially as to the location of the eutectic, with the predictions of Epstein and Howland and the experimental results of Lambertson and Mueller. However, there was no indication of the formation or existence of a two-liquid immiscibility region or any significant departures from idealized liquidus surface curves on either side of the eutectic. In addition, the present study showed that there was no compound or solid-solution formations at temperatures from 800° to $1,800^\circ \text{C}$ within the compositional range 10 to 90 mole percent of Al_2O_3 .

b. $\text{UO}_2\text{-Y}_2\text{O}_3$ (Fig. 9)

Anderson [7] stated that the system should be of interest from the solid-solution viewpoint because Y_2O_3 and UO_2 have X-ray diffraction peaks at about the same d -values and because the UO_2 -oxygen solid solution is uranium deficient, whereas the possible $\text{UO}_2\text{-Y}_2\text{O}_3$ solid solution would be oxygen deficient. He reasoned that the $\text{UO}_2\text{-Y}_2\text{O}_3$ solid-solution structure would have less defects than the UO_2 -oxygen solid-solution structure. He heated a series of $\text{UO}_2\text{-Y}_2\text{O}_3$ mixtures at $2,000^\circ \text{C}$. After determining their lattice constants, he stated that the miscibility at $2,000^\circ \text{C}$ is almost complete and that the two-phase

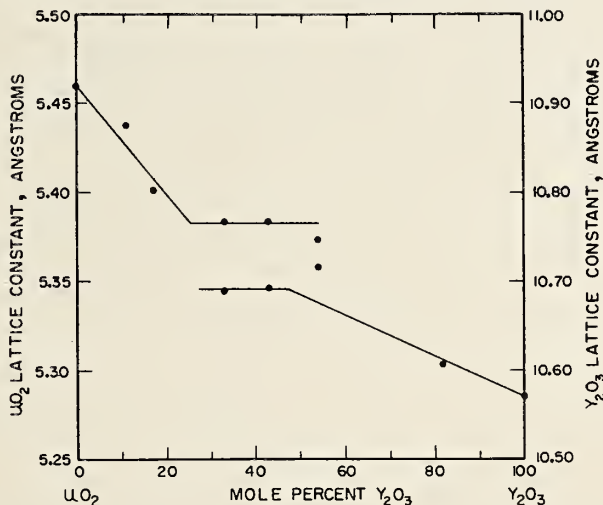

FIGURE 9. Lattice constants of the $\text{UO}_2\text{-Y}_2\text{O}_3$ system according to Anderson

J. S. Anderson, Recent work on the chemistry of the uranium oxides, *Bul. soc. chem. (France)* p. 781, 1953.

c. $\text{UO}_2\text{-Nd}_2\text{O}_3$ (Fig. 10)

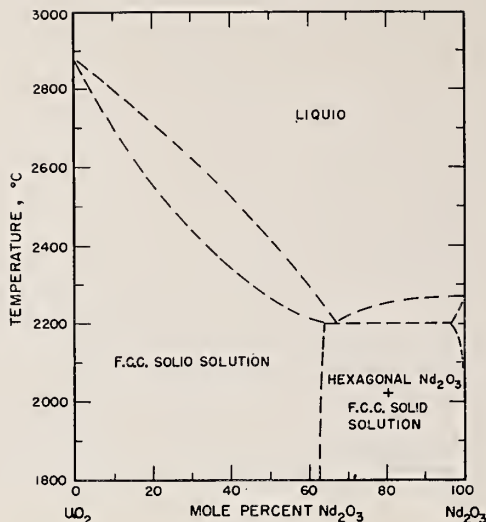

FIGURE 10. *The system $\text{UO}_2\text{-Nd}_2\text{O}_3$ according to Lambertson and Mueller.*

W. A. Lambertson and M. H. Mueller, Uranium oxide phase equilibrium systems: V, $\text{UO}_2\text{-Nd}_2\text{O}_3$, . . . U. S. AEC unclassified report ANL-5312 (Sept. 14, 1954). The figure was redrawn from the figure for the system $\text{UO}_2\text{-NdO}_{1.5}$.

region between about 25 and 55 mole percent of Y_2O_3 probably disappears at higher temperatures.

Many trivalent-tetravalent cation systems, in which the cation radii are of about the same size, contain pyrochlore-type compounds ($\text{A}_2^3\text{B}_2^4\text{C}_7^{-2}$) with a doubled, face-centered cubic cell. For this reason, a 1:2 mole ratio $\text{Y}_2\text{O}_3\text{-UO}_2$ mixture was heated at $1,600^\circ\text{C}$ for 1 hour in an argon atmosphere and furnace cooled. The X-ray diffraction pattern showed that the sample contained a UO_2 solid-solution phase with a lattice constant of 5.351 Å and a very slight amount of a probable Y_2O_3 solid-solution phase. If the heat treatment had produced a pyrochlore-type compound, the mixture should have formed a single phase, and doubling the unit cell size would have resulted in the appearance of many more diffraction peaks.

An extensive face-centered, cubic solid-solution region of neodymia in urania, from UO_2 to about 64 mole percent of Nd_2O_3 at about $2,200^\circ\text{C}$, was reported by Lambertson and Mueller [17] for the system $\text{UO}_2\text{-Nd}_2\text{O}_3$. Solid solution of urania in neodymia could not be detected in samples heated at lower temperatures, but there was some indication that limited solubility occurred in samples heated above $2,000^\circ\text{C}$. It was stated that, although the urania and neodymia structures and the cation valences are different, the ionic cation sizes are equivalent, 0.98 Å for Nd^{+3} to 0.97 Å for U^{+4} , and substitution of Nd^{+3} for U^{+4} could be accommodated if either oxygen is removed or if some U^{+4} is changed to U^{+6} to maintain the electrostatic neutrality of the system. Lambertson and Mueller show that the neodymia-in-urania solid solution is oxygen deficient. Because the neodymia used was only 85.2 percent pure (the remainder being mainly Sm_2O_3 with lesser amounts of Pr_2O_3 and SiO_2), they conceded that the boundary

lines shown are not exact but are probably accurate enough for most practical purposes. However, a small amount of pure oxide was available for the melting-point determination of Nd_2O_3 . This was found to be $2,270^\circ \pm 20^\circ \text{C}$. The eutectic was located at about 66 mole percent of Nd_2O_3 and about $2,200^\circ \text{C}$.

Because of the possible existence of an $\text{A}_2^{+3}\text{B}_2^{+4}\text{O}_7^{-2}$ pyrochlore-type compound in this system, a 1:2 mole ratio $\text{Nd}_2\text{O}_3\text{-UO}_2$ mixture was prepared, heated at $1,600^\circ \text{C}$ for 1 hour in an argon atmosphere, and furnace-cooled. The X-ray diffraction pattern showed that the sample consisted of a single, fluorite-type, cubic phase, with a lattice constant of 5.449 Å.

The presence of the single phase indicated that the mixture had formed a compound or a solid solution. However, the back-reflection lines were sharper than would be expected for such a solid solution. If a solid solution had formed, they should have been relatively broad, poorly defined peaks. It is known⁴ that neodymia forms pyrochlore-type compounds with TiO_2 , SnO_2 , and ZrO_2 , and that the superstructure lines for these compounds decrease in intensity as the tetravalent ions become heavier. For $\text{Nd}_2\text{Zr}_2\text{O}_7$, in fact, there are only 3 or 4 very weak extra lines when the unit cell is doubled. This would seem to indicate that a $\text{Nd}_2\text{O}_3\text{-UO}_2$, pyrochlore-type compound might have formed, but its existence cannot be substantiated from the available data. The possibility also exists that the mixture was such that the defect-fluorite-type solid solution had formed instead of the pyrochlore compound.

There has been some question as to whether a urania compound of the zircon type exists in natural deposits. A urania mineral from the

3.3. $\text{UO}_2\text{-MO}_2$ Systems

a. $\text{UO}_2\text{-SiO}_2$ (Fig. 11)

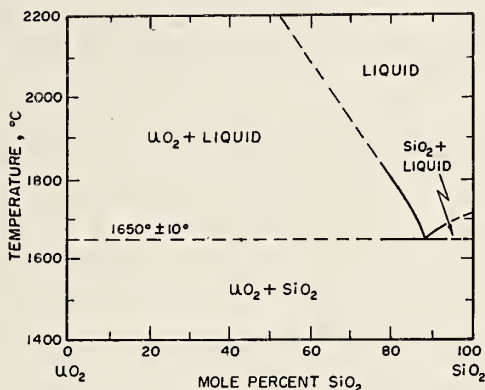

FIGURE 11. The system $\text{UO}_2\text{-SiO}_2$.

No compound or solid-solution formations occurred at temperatures from 800° to $1,600^\circ \text{C}$ within the compositional range 10 to 90 mole percent of SiO_2 .

⁴ R. S. Roth, Pyrochlore-type compounds containing double oxides of trivalent and tetravalent ions, *J. Research NBS* **56**, (Jan. 1956) RP2643, describes the known and discusses the probable pyrochlore-type compounds of this type.

Colorado plateau⁵ was found to give an X-ray diffraction pattern very similar to that of zircon.

| | Lattice constants | | <i>c/a</i> |
|---------------------|-------------------|------------------|------------|
| | <i>a</i> | <i>c</i> | |
| Zircon----- | <i>A</i> 6.58 | <i>A</i> 5.93 | 0.90 |
| Urania mineral----- | 6.93 | 6.25 | .91 |

In the present study, the urania analogue of zircon could not be synthesized, there were no compound or solid-solution formations at temperatures from about 800° to 1,600° C within the compositional range 10 to 90 mole percent of SiO₂. The melting-point data, obtained for UO₂-SiO₂ mixtures in the region of the eutectic, indicate it to be located at about 1,650° ± 10° C and about 85 to 90 mole percent of SiO₂. The precision of these values probably is not good because of the sluggish attainment of equilibrium conditions. This is due to high liquid viscosities in those mixtures containing 90 or more mole percent of SiO₂ and to the formation of large quench-growth crystals in mixtures surrounding the eutectic composition. Such crystallizations often masked the partial equilibrium conditions attained at the quenching temperature.

b. UO₂-ZrO₂ (Fig. 12)

As has been the case in systems containing zirconium oxide (ZrO₂), Lambertson and Mueller [18] have had to speculate on the configuration of the equilibrium diagram for the zirconia-rich region. They show that extensive solid-solution fields exist in the system, and they give the eutectic as being at about 2,550° C and 53 mole percent of ZrO₂. The melting point of zirconia (containing 2 weight percent of HfO₂, 0.02 weight percent of SiO₂, and not more than 0.005 weight percent of any other impurity) is reported to be 2,710° ± 10° C [19, 20].

Lambertson and Mueller [18] showed that cubic UO₂ will take about 40 to 53 mole percent of ZrO₂ into solid solution at temperatures from 1,000° to 2,550° C. Tetragonal ZrO₂ will take about 20 mole percent of UO₂ into solid solution at temperatures up to about 1,700° C; then, the solubility increases rapidly to about 40 mole percent at 1,920° C. Above this temperature in the zirconia-rich portion of the diagram, a ZrO₂ solid solution of unknown structure exists. The boundary between this field and that for the UO₂, face-centered, cubic solid solution is given as a single line because the separation was found, experimentally, to be less than 2 weight percent, and the authors state that they do not believe that a two-phase field (as required by the phase rule) could exist in such a narrow region over such a large temperature range. They propose two possibilities: first, if the high-temperature modification of ZrO₂ is hexagonal, as reported by Cohen [21], a second-order transformation is possible of the type proposed by Stout [22] and reported in the system indium-thallium

⁵ Obtained through the courtesy of L. R. Stieff and T. W. Stern, U. S. Geological Survey, Naval Gun Factory, Washington 25, D. C. Described in Identification and occurrence of uranium and vanadium minerals from the Colorado Plateaus, U. S. Geol. Survey Bul. 1009-B, p. 31 (1954).

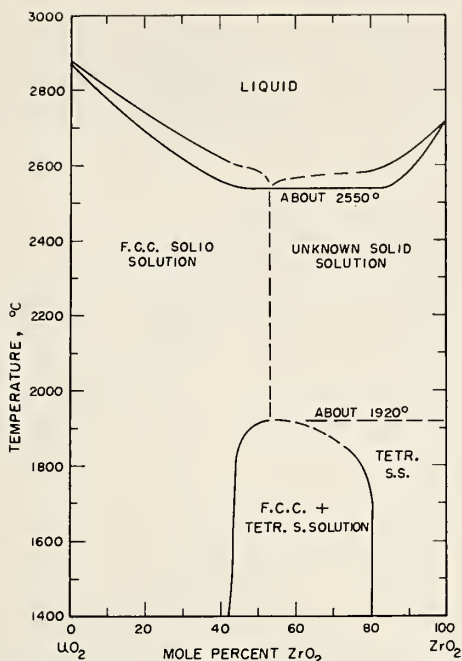

FIGURE 12. *The system $\text{UO}_2\text{-ZrO}_2$, according to Lambertson and Mueller.*

W. A. Lambertson and M. H. Mueller, Uranium oxide phase equilibrium systems: III, $\text{UO}_2\text{-ZrO}_2$, *J. Am. Ceram. Soc.* **36**, 365 (1953).

[23]. The second possibility discussed is that the high-temperature modification of ZrO_2 is cubic and that there is complete solid solution between ZrO_2 and UO_2 .

Unfortunately, when quenched from all temperatures up to and above the melting temperature, ZrO_2 was always obtained and identified as the monoclinic form. It was found that below the monoclinic to tetragonal inversion temperature at about $1,000^\circ\text{C}$, ZrO_2 will take up to 20 mole percent of UO_2 into solid solution and that this solid solution lowers the monoclinic-tetragonal transformation temperature.

c. $\text{UO}_2\text{-SnO}_2$

Mixtures in this system were prepared at 10-mole-percent intervals and were heated in a purified helium atmosphere at temperatures from 600° to $1,400^\circ\text{C}$ for periods of up to 5 hours. Examinations of the X-ray diffraction patterns for these mixtures revealed no compound or solid-solution formations. Although no oxidation of the UO_2 was found, rapid volatilization of SnO_2 occurred when the mixtures were heated at temperatures above $1,400^\circ\text{C}$. Therefore, no further study of this system was made.

d. $\text{UO}_2\text{-CeO}_2$ (Fig. 13)

Formation of a deep-blue material by crystallization in MgCl_2 and by chemical precipitation, both having approximately the same composition, led Hofmann and Hoschele [24] to state that the deep-blue

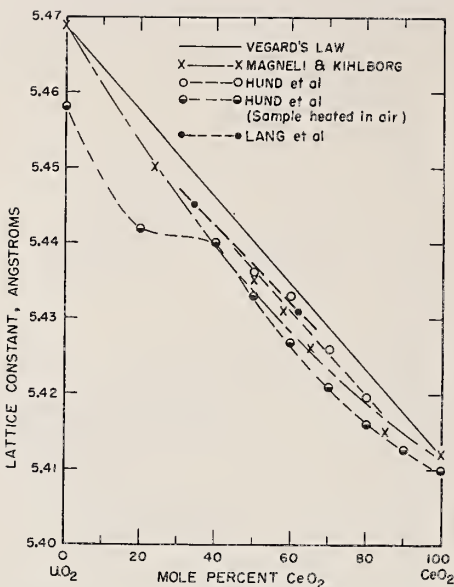

FIGURE 13. Lattice constants of the $\text{UO}_2\text{-CeO}_2$ system.

L. Vegard, *Z. Physik* 5, 17 (1921); A. Magneli and L. Kihlberg, On the cerium dioxide-uranium dioxide system and cerium uranium blue, *Acta Chem. Scand.* 5, 578 (1951); F. Hund, R. Wagner, and U. Peetz, Abnormal mixed-crystals in the system cerium oxide-uranium oxide, *Z. Elektrochem.* 56, 61 (1952).

double oxide is a compound ($2\text{CeO}_2\cdot\text{UO}_2$), not a mixture. Because both components crystallize as a fluorite-type cube, and because their lattice constants are quite similar, Magneli and Kihlberg [25] believed that such a compound was unlikely. They heated intimate mixtures of the two oxides in evacuated silica tubes at $1,000^\circ\text{C}$ for several days, and all mixtures were dark blue or blue-black. Their X-ray photographs of these heat-treated mixtures showed that (a) the dark-blue cubic crystals of "cerium-uranium blue" found by Hofmann and Hoschele were of variable composition, and (b) the two components form a continuous solid-solution series, $(\text{Ce}, \text{U})\text{O}_2$, crystallizing with the cubic, fluorite-type lattice. Essential substantiation of these results was found when Rudorff and Valet [26] prepared a series of $\text{UO}_2\text{-CeO}_2$ solid solutions by igniting Ce^{+4} and U^{+4} salts at $1,200^\circ\text{C}$ in vacuum. All of the crystals were blue.

Hund, Wagner, and Peetz [27] heated a series of uranyl nitrate and cerium nitrate mixtures at $1,200^\circ\text{C}$ in vacuum and in an air atmosphere. They found that, after heating in air, a fluorite-type, cubic solid-solution phase ($a=5.410$ to 5.442 Å) existed between 100 and about 37 mole percent of CeO_2 . Between 37 and 0 mole percent of CeO_2 , they found the fluorite solid solution and rhombic U_3O_8 . Data are given only for a few mixtures between 50 and 80 mole percent of CeO_2 heated in vacuum, but the similarity of results would seem to indicate that the $\text{UO}_2\text{-CeO}_2$ solid-solution series does not undergo the large volume changes associated with the normal oxidation of UO_2 to U_3O_8 .

In the present study, two $\text{UO}_2\text{-CeO}_2$ mixtures, containing about 35 and about 60 mole percent of CeO_2 , were heated at $1,700^\circ$ and at $1,900^\circ\text{C}$ in argon. X-ray diffraction results indicated that the lower

CeO₂-content mixture contained two cubic, fluorite-type solid solutions of very nearly equivalent parameters, as shown by doublet peaks for the normal solid solution ($a=5.445$ Å). The 60-mole-percent-CeO₂ mixture was a single-phase, cubic solid solution, with a lattice constant of 5.431 Å.

e. UO₂-ThO₂ (Figs. 14 and 15)

Trzebiatowski and Selwood [28] described the crystallographic lattice constants for the UO₂-ThO₂ solid-solution series. These were prepared by decomposition of co-precipitates of ammonium uranate and thorium hydroxide, which were heated at 1,200° C for 3 hours in a hydrogen atmosphere. Values from 5.467 Å for a 10-mole-percent-ThO₂ mixture to 5.588 Å for a 98-mole-percent-ThO₂ mixture were reported. From the theoretical standpoint, a somewhat better relation was given by Slowinski and Elliott [29] for another UO₂-ThO₂ solid-solution series prepared from an intimate mixture of very pure oxides. These mixtures were heated in a hydrogen atmosphere, 2 to 4 hours at 1,000° to 1,200° C in the presence of a borax flux. The values were converted from kX to angstrom units and are 5.468 Å for pure UO₂ to 5.597 Å for pure ThO₂. The lattice parameter for pure ThO₂ was reported by Swanson and Tatge [30] as being 5.5997 Å. All of the Slowinski and Elliott values are in accord with the relationship imposed by Vegard's law [31].

As an exploratory study, a number of UO₂-ThO₂ mixtures, prepared at 20-mole-percent intervals, were heated in helium at 1,575° C for about 20 hours. Because of an air leak during this experiment, some of the specimens were slightly oxidized during the test, and the lattice constant values of the solid-solution phase did not show the theoretically required linear relation with respect to composition. A maximum deviation of 0.013 Å was obtained. When the work of Lambertson, Mueller, and Gunzel [19] became available, which was consistent with that of Slowinski and Elliott [29], it did not appear necessary to repeat the experiment.

Mixtures of thorium and uranyl nitrates were prepared and heated at 1,200° C in air by Hund and Niessen [32]. They found that a cubic, fluorite-type solid-solution phase exists between 100 and about 44 mole percent of ThO₂, with the lattice constant varying from 5.595 to 5.485 Å. From 44 to 0 mole percent of ThO₂, there is a two-phase region composed of the same cubic, fluorite-type solid solution and U₃O₈. The lattice-constant data determined by Slowinski and Elliott [29] and Lambertson et al. [19], (all of which were obtained by using samples heated in a neutral or reducing atmosphere) and the data for the cubic, fluorite-type phase (obtained by Hund and Niessen with samples heated in air) are shown on figure 14.

Anderson [7] discussed some preliminary results for the oxidation of the UO₂-ThO₂ solid-solution series and attributed some of the oxidation to a valence change of the uranium ion. In a later report, Anderson and coworkers [33] discussed the oxidation of a series of solid solutions of the general formula U_{*x*}Th_{1-*x*}O₂. They measured the additional oxygen of the oxidized phases, and the structure and density were then determined as a function of the oxygen content. When "*x*" was less than 0.5 (50 mole % UO₂) oxidation under any conditions at temperatures up to 1,400° C yielded only a cubic, fluorite-type solid-solution phase. When "*x*" was greater than 0.5, the same

fluorite-type phase was found along with a U_3O_8 -like phase. The gross formula of the completely oxidized fluorite-type solid solution was $MO_{2.32}$ to $MO_{2.35}$. They found no evidence that any type of defect other than interstitial oxygen anions are introduced into any of the

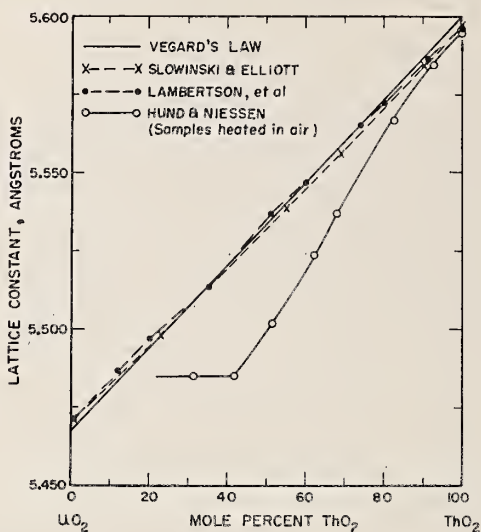

FIGURE 14. *Lattice constants of the UO_2 - ThO_2 system.*

L. Vegard, *Z. Physik* 5, 17 (1921); E. Slowinsky and N. Elliott, Lattice constants and magnetic susceptibilities of solid solutions of uranium and thorium dioxide, *Acta Cryst.* 5, 768 (1952); W. A. Lambertson, M. H. Mueller, and F. H. Gunzel, Jr., Uranium oxide phase equilibrium systems: IV, UO_2 - ThO_2 ; *J. Am. Ceram. Soc.* 36, 397 (1953); F. Hund and G. Niessen, Abnormal mixed-crystals in the system thorium oxide-uranium oxide, *Z. Elektrochem.* 56, 972 (1952).

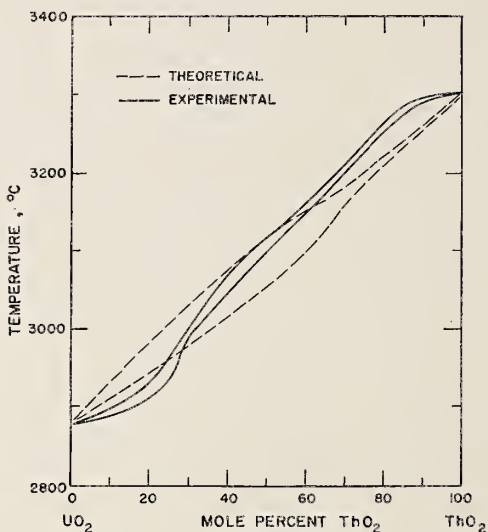

FIGURE 15. *The system UO_2 - ThO_2 , according to Lambertson, et al.*

W. A. Lambertson, M. H. Mueller, and F. H. Gunzel, Jr., Uranium oxide phase equilibrium systems: IV, UO_2 - ThO_2 , *J. Am. Ceram. Soc.* 36, 397 (1953).

fluorite-type phases during the oxidation treatments. It was shown that the unit cell size for the fluorite-type phase contracted as the average uranium valency increased from 4.0 to 5.0, and that it began to expand as the average uranium valency increased from 5.0 to 5.5. Therefore, they stated that the oxidized phases cannot be regarded as solid solutions of ThO_2 and any known higher oxides of uranium other than UO_2 .

Samples from this same study [33] were used by Roberts [8]. He found that at -183°C oxygen was rapidly chemisorbed by fresh surfaces of highly sintered $\text{UO}_2\text{-ThO}_2$ solid-solution crystals if the surface was prepared by crushing, but that the rate was singularly lower when the fresh surfaces were prepared by reducing oxidized solid-solution samples at $1,200^\circ$ to $1,400^\circ\text{C}$. The oxidation rates, for the tests at 0° and 23°C , were higher by at least a factor of 10 for the crushed crystals having low uranium content (less than about 60 mole percent of UO_2) than for the reduced samples. Roberts stated that these results imply that Th^{+4} ions had been preferentially concentrated in the surface layer or layers of the reduced solid-solution samples in the dilute uranium range. Some of the possibilities for this concentration are discussed.

Actual measurements of the liquidus and solidus temperatures for the $\text{UO}_2\text{-ThO}_2$ solid-solution series were made by Lambertson, Mueller, and Gunzel [19]. Their results are shown on figure 15. In addition, they calculated the theoretical liquidus and solidus temperature from thermodynamic laws and found that the maximum deviations of the experimental from the theoretical values were of the order of 50°C . They give the melting point of ThO_2 as $3,300^\circ \pm 100^\circ\text{C}$, compared to the extrapolated value of $3,050^\circ\text{C}$ given by von Wartenberg [20].

3.4. $\text{UO}_2\text{-M}_2\text{O}_5$ Systems

Only one $\text{UO}_2\text{-M}_2\text{O}_5$ system was investigated. During the study of that system, $\text{UO}_2\text{-V}_2\text{O}_5$, considerable volatilization of the vanadium component occurred, even at 700°C . Usually, this was sufficient to cause a reaction with (a) the mullite of the quenching hanger, (b) the platinum-rhodium alloys of the thermocouple and specimen hanger wires, and (c) the platinum sample containers. Because V_2O_5 has a vapor pressure similar to or lower than As_2O_5 and P_2O_5 , and because destructive reactions of the type described also could be anticipated with these pentoxides, it was deemed inadvisable to undertake the study of the $\text{UO}_2\text{-As}_2\text{O}_5$ and the $\text{UO}_2\text{-P}_2\text{O}_5$ or any other UO_2 -pentoxide system.

a. $\text{UO}_2\text{-V}_2\text{O}_5$

Although the equilibria in the vanadium-oxygen system is almost as complex as that of the uranium-oxygen system, a number of $\text{UO}_2\text{-V}_2\text{O}_5$ mixtures were heated at 700° and at 900°C in a helium atmosphere for periods ranging up to 24 hours. It was found that the UO_2 reduced the V_2O_5 to VO_2 . At the same time, the UO_2 had been oxidized to a variable composition with its oxygen content greater than $\text{UO}_{2.2}$ but less than $\text{UO}_{2.66}$ (U_3O_8), depending upon the original composition. The vanadium pentoxide did not dissociate when heated alone in the helium atmosphere. X-ray diffraction examination of the quenched $\text{UO}_2\text{-V}_2\text{O}_5$ specimens, in which most of the pentoxide was reduced to VO_2 , indicated that the reduced system $\text{UO}_2\text{-VO}_2$ might prove to be

interesting for pure research. Two unknown phases were found in most of the heat-treated samples, and it is believed that these are $\text{VO}_2\cdot\text{UO}_2$ and $3\text{VO}_2\cdot\text{UO}_2$. There is the possibility that one of these phases may be a vanadium-uranium-oxygen substitutional-type solid-solution $(\text{V,U})\text{O}_2$.

4. Summary

Although considerable work has been done by many investigators in the study of the equilibrium relations of the uranium-oxygen system, much additional work will be required for a satisfactory understanding of the system. For example, the literature survey showed that a number of investigations were reported before the need for accurate control and precise analytical procedures for uranium and oxygen was appreciated; and, it was some time before it was known that the previous thermal history of the starting material influenced the results of later thermal treatments. Although the role of water vapor is not known, it appears to have a considerable effect on the "oxidation" of UO_2 .

Binary systems of UO_2 with BeO , MgO , Al_2O_3 , and SiO_2 show no compound or solid-solution formations. Equilibrium diagrams showing the liquidus temperatures are given for these systems. The reported two-liquid immiscibility regions in the $\text{UO}_2\text{-MgO}$ and $\text{UO}_2\text{-Al}_2\text{O}_3$ systems were not substantiated by the present investigation. The system $\text{UO}_2\text{-SnO}_2$ contains no solid solution or compound formation at temperatures up to $1,400^\circ\text{C}$; above this temperature volatilization of SnO_2 was so rapid that the investigation of the system was not continued.

Binary systems of UO_2 with Y_2O_3 , Nd_2O_3 , ZrO_2 , CeO_2 , and ThO_2 show extensive or complete solid solutions without compound formation, although the possibility exists that a pyrochlore-type compound, $\text{Nd}_2\text{U}_2\text{O}_7$, exists in the neodymia system. Equilibrium diagrams showing liquidus temperatures are given for the $\text{UO}_2\text{-Nd}_2\text{O}_3$, $\text{UO}_2\text{-ZrO}_2$, and $\text{UO}_2\text{-ThO}_2$ systems.

Binary systems of the alkaline earth oxides, CaO , SrO , and BaO , show both solid-solution and compound formations at temperatures below about $1,950^\circ\text{C}$. An equilibrium diagram is given for the $\text{UO}_2\text{-CaO}$ system. The reported urania-lime compounds and their structures could not be correlated with the X-ray diffraction data obtained in the present investigation. Diffraction data and a new structure are given for an orthorhombic, perovskite-type compound, $\text{Ca}(\text{U,Ca})\text{O}_x$, which is believed to be formed. Diffraction data and proposed structures are given also for the orthorhombic, perovskite-type $\text{Sr}(\text{U,Sr})\text{O}_x$ and for the pseudo-cubic, perovskite-type BaUO_3 compounds.

The very strong reducing power of UO_2 was indicated when intimate mixtures of UO_2 with CuO and with V_2O_5 were heated at low temperatures, i. e., 700° and 900°C . Samples of these heat-treated mixtures contained uranium in an oxidized state and copper and vanadium oxides in a reduced form. Although V_2O_5 did not dissociate merely by being heated in a helium atmosphere, CuO and Cu_2O did. There appears to be no binary system of UO_2 with a copper oxide at atmospheric pressure. However, evidence was obtained to indicate that the system $\text{UO}_2\text{-VO}_2$ does exist and that it contains either two compounds or one compound and a solid-solution phase.

5. Appendix

Only those materials, equipment, and procedures applicable to the data obtained at the National Bureau of Standards are described. Recourse to the cited literature references will provide detailed information for the other contributions.

5.1 Materials

All of the materials used for the detailed phase-equilibrium studies were of the highest purity available and, in all instances, were sufficiently finely divided to pass the No. 325 U. S. Standard Sieve.

Uranium dioxide (UO_2). Supplied by the U. S. Atomic Energy Commission, St. Louis Warehouse, in purified form. Chemical analysis at the Bureau showed 88.0 percent of uranium. If the remainder is considered to be oxygen, this is equivalent to the formula $\text{UO}_{2.03}$. Spectrographic analysis at the Bureau showed the presence of 0.001 to 0.006 percent each of aluminum, calcium, copper, iron, sodium, and silicon, and 0.0001 to 0.001 percent each of beryllium, chromium, magnesium, manganese, nickel, lead, and tin. Subtracting the total of these impurities from the oxygen remainder would give a more nearly 1:2 uranium-oxygen ratio. The presence of beryllium, even at low concentration, is unusual in purified uranium [34]. Swanson and Fuyat [35] determined the crystallographic lattice constant of a sample of this UO_2 as being 5.4682 Å at 26° C. The structure is a face-centered cubic lattice, space group $\text{O}_h^2 = \text{Fm}\bar{3}\text{m}$, fluorite-type, with 4 (UO_2) per unit cell. The density of uranium dioxide calculated from the NBS lattice constant is 10.968 g/cm³ at 26° C.

Aluminum oxide (Al_2O_3). "Alpha" polishing powder of nominal 99.9-percent purity, supplied by the Linde Air Products Co.

Beryllium oxide (BeO). "Fluorescent-grade" material of over 99.9-percent purity.

Cupric oxide (CuO) and *cuprous oxide* (Cu_2O). ACS reagent-grade materials of at least 98-percent purity.

Magnesium oxide (MgO). Water-clear crystals of artificial periclase of over 99-percent purity, supplied by the Norton Co. Spectrochemical analysis at the Bureau showed a moderate line for calcium; weak lines for aluminum, silicon, and titanium; and trace or faint-trace quantities for boron, beryllium, chromium, copper, iron, and manganese.

Silicon dioxide (SiO_2). Pulverized, selected "rock crystal", quartz of over 99-percent purity. Spectrochemical analysis at the Bureau showed a moderate line for aluminum, weak lines for copper and titanium, and only trace quantities for silver, beryllium, calcium, iron, magnesium, sodium, and zirconium.

Tin oxide (SnO_2). Specially prepared 98.5-percent purity, pilot-plant material, supplied by the Metal & Thermit Corporation.

Thorium dioxide (ThO_2). Lindsay Light & Power Co. low-temperature, calcined material of 99.99-percent purity.

Vanadium pentoxide (V_2O_5). ACS reagent-grade material of 98-percent purity.

5.2 Equipment

a. Moderate Temperature Furnace (1,600° C max)

For the study of equilibrium reactions at temperatures up to 1,600° C a conventional, platinum-wound quenching furnace was modified to provide a high-purity controlled atmosphere in order to maintain UO_2 in an unoxidized state during heating. Before being passed into the furnace chamber, oil-free, double-charcoal-purified helium, supplied by the U. S. Bureau of Mines, was further treated to remove any water vapor and any residual traces of oxygen present.

For the removal of water, the helium gas was passed through calcium sulfate, magnesium perchlorate, and a large-volume tube immersed in a liquid-nitrogen bath. The bath was maintained at a constant level by the air-pressure method described by Zweig [36], with a slight modification of the timing-cycle control equipment.

For the elimination of residual oxygen, the dried helium gas was passed through a large-volume Inconel V tube, filled with titanium-metal turnings, that was heated at about 850° C. A second "oxygen-getter" stage consisted of another Inconel V tube in which the central section was filled with tantalum wool and both ends packed with bright copper metal turnings. The central portion of the tube was heated to about 950° C; by radiation and conduction, those sections filled with the copper attained a temperature of about 600° C.

At the furnace, the atmosphere system was connected to a 4-in. diameter brass loading-chamber in which insulated and vacuum-tight entries provide four electric-quenching circuits, a thermocouple circuit, and a vacuum-gage port. The loading chamber was fastened to an impervious Al_2O_3 tube, using a brass and silicone-rubber O-ring fitting. A similar fitting at the bottom of the furnace (both were air-cooled) was attached to a 6-in.-long, 1½-in.-inside-diameter copper tube, in the bottom of which a small bed of tantalum wool was packed. Before a sample was dropped from the hot zone, a metal container was placed around the copper tube. The container was filled with liquid nitrogen a few minutes before the quench was made. It is estimated that the interior temperature at and surrounding the tantalum-wool bed was at about -100° C when a sample was dropped from the hot zone. A line from the copper quenching container to an escape-bubbler filled with mineral oil was the last stage of the helium-atmosphere system.

The piping of the entire atmosphere system was copper tubing. All joints and fittings were soft-soldered and painted with Glyptol. Entry and exit lines for the Inconel tubes were water-cooled to preserve the soldered joints. The system was evacuated to 10 to 15 microns of Hg absolute pressure, using a mechanical pump, in from 4 to 6 hours. Absolute pressures of 30 microns of Hg were obtained in about 15 minutes.

Temperatures were measured with a 90-percent platinum-10-percent rhodium thermocouple, which was calibrated frequently. Temperature control was established by using a modified, Roberts Wheatstone-bridge-type, power controller, in which one arm of the bridge was the furnace heating coil. The furnace temperature could be regulated easily to ± 0.5 deg C, although drift of the coil resistance and changes in ambient temperature could cause sample-temperature changes of about 5 deg C if the equipment was left unattended for periods of 12 hours or more.

b. High-Temperature Melting-Point Furnace (+2,500° C)

From the information developed at other laboratories and from theoretical thermodynamic calculations of probable melting-point values, it was known that, in order to determine the liquidus temperatures of many UO_2 -metal oxide mixtures, a furnace would be required that could attain temperatures of at least 2,500° C. High-frequency equipment for inductive heating was not available. A metallic-resistance melting-point furnace, which could be heated and cooled in a matter of minutes, was constructed from an original design by Burgess [37] as modified by Stratton [38].

Figure 16 shows the essential features of the furnace. At the top of the diagram are shown some of the heaters used in early trials. These heaters have been fabricated from molybdenum, tantalum, and tungsten, using foil 5 and 10 mils thick, ordinarily $2\frac{1}{4}$ in. long by $\frac{1}{4}$ in. wide. When heated in an atmosphere of helium or argon, molybdenum heaters would attain a temperature of about 2,200° C before failure; tantalum and tungsten were heated to the limit of the optical pyrometer (2,850° C) without failure. However, oxide mixtures heated in contact with these materials (1) would become coated with metallic particles from the heaters, (2) would cause heater failures due to reactions, (3) could not be heated to a uniform temperature, and (4) were difficult to view, because of their small size, against the bright-strip background. Use of the helical-strip heater eliminated the difficulties described in (2) and (3). However, sagging of the helix, blocking the line of sight, was a troublesome problem.

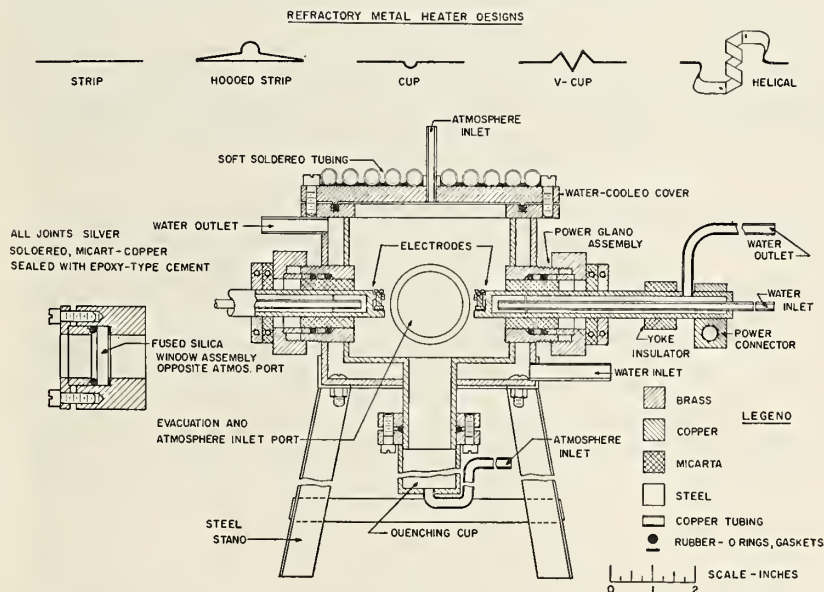

FIGURE 16. High-temperature atmosphere-controlled melting-point furnace.

After a number of modifications, a graphite-resistance heater was developed, figure 17, which attained a temperature of at least 2,850° C, although its life was severely limited at temperatures in excess of about

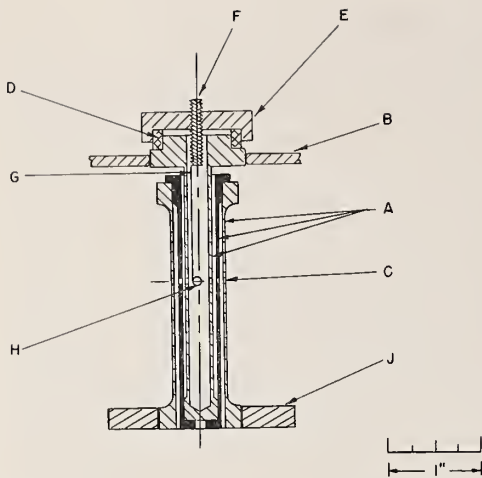

FIGURE 17. [Graphite-resistance heater] for melting-point furnace.

A cascade-type heater for which A indicates three thin-walled graphite cylinders; B, molybdenum rod power-leads; C, viewing ports through the graphite cylinders; D, a BeO or ZrO₂ insulator; E, a graphite cap in which a graphite screw, F, locates the specimen, H, suspended by tungsten or tantalum wire, G; J is a graphite-ring power-lead.

2,450° C. The heater consisted of three concentric, thin-walled cylinders connected in series for a cascading-heating effect, and so arranged that no displacement of the three in-line sight holes occurred during use. A similar design, employing 1- or 2-mil tungsten foil, was used also. Here again, recurrent failures of the heater at temperatures above 2,500° C caused expensive and time-consuming repairs. During the limited period this furnace was in operation, no really satisfactory heater for sustained use at 2,500° C or higher was devised.

At temperatures in excess of 2,000° C, the furnace could be controlled to within 5 deg C without difficulty. Temperatures were measured by using an optical pyrometer, the secondary calibration of which was obtained by using the melting points of various oxide mixtures. These data are given in table 5.

TABLE 5. Secondary calibration of the optical pyrometer ^a

| Test specimens | | Melting-point furnace data | | |
|---|-----------------------------------|--|--------------------------------|----------------------------------|
| Composition (mole ratio) | Melting point ^b in air | Observed melting point ^c in argon | Window ^d correction | Corrected melting point in argon |
| | °C | °C | °C | °C |
| 4MgO:5BcO:3ZrO ₂ ----- | 1,689 to 1,693----- | 1,680 | +18 | 1,698 |
| 2BcO:2Al ₂ O ₃ :1ZrO ₂ ----- | 1,760 to 1,765----- | 1,762 | +19 | 1,781 |
| 4BeO:4Al ₂ O ₃ :1ThO ₂ ----- | 1,810----- | 1,788 | +20 | 1,808 |
| 1BeO:1Al ₂ O ₃ :2ThO ₂ ----- | 1,800 to 1,805----- | ° 1,790 | +20 | 1,810 |
| 4Al ₂ O ₃ :1ThO ₂ ----- | 1,910----- | ° 1,894 | +22 | 1,916 |
| 1Al ₂ O ₃ :1ThO ₂ ----- | 1,910 to 1,915----- | 1,897 | +22 | 1,919 |
| 3Al ₂ O ₃ :1ThO ₂ ----- | 1,910 to 1,915----- | ° 1,897 | +22 | 1,919 |
| Al ₂ O ₃ ----- | 2,035----- | 2,025 | +24 | 2,049 |
| BcO----- | ^f 2,510----- | 2,418 | +34. | 2,452 |

^a Determinations were made in an argon atmosphere, using presintered specimen rods suspended in the cascade-type heater (fig. 17) of the melting-point furnace.
^b Determinations were made in the air atmosphere of the thorium resistor-type furnace. Temperatures were measured under black-body conditions, using a calibrated optical pyrometer.
^c The average of five tests, except as indicated; all ±2 deg C of the value reported.
^d Calculated correction for a fused-silica window about ¼ in. thick.
^e The average of three tests.
^f A literature value.

No purification system was employed for the neutral atmospheres used with this furnace because of the small volume of the furnace chamber and because the specimens were heated for very short periods of time. Elimination of oxygen was accomplished by repeated evacuation of the furnace chamber. After about 5 minutes of operation, the evacuating system produced an absolute pressure of 5×10^{-5} mm Hg at the entry port of the furnace chamber.

5.3 Procedures

All mixtures were prepared as 15,000-g batches; weights of each constituent were readjusted for their ignition losses (1 hr at 1,250° C). Two-ounce glass bottles, each containing six Lucite pebbles $\frac{1}{2}$ -in. in diameter by $\frac{1}{2}$ in. long, were used to mix the batches for at least 8 hours on a 70-rpm wheel. At 2-hour intervals, the bottles were removed from the mixer and shaken by hand to dislodge any packed material which might have accumulated.

a. Low-Temperature Tests

Small crucibles ($\frac{1}{8}$ in. in diameter by $\frac{1}{2}$ in. long) fabricated of $\frac{1}{2}$ -mil platinum foil were used as sample containers for the tests at temperatures up to 1,600° C. Each crucible contained approximately 0.15 to 0.20 g of material, either as a powder or as a pressed pellet. Platinum wire, 2 mils in diameter, was used to suspend from 1 to 15 crucibles from the quenching hanger. After the samples were loaded into the furnace and the covers secured, the furnace chamber was twice evacuated and flushed with the processed helium gas. A third evacuation followed by a helium flushing was made just prior to the heating. When containers were loaded in the normal laboratory atmosphere, it was necessary that they have large openings so that all of the air could be removed during evacuation of the furnace chamber, although this sometimes resulted in the loss of samples during quenching.

Containers closed in the laboratory atmosphere resulted in oxidation of the urania because of the enclosed air. When containers were closed in a helium-filled atmosphere they usually were satisfactory but this was a tedious and time-consuming process and had to be done immediately prior to the loading and heating of the furnace. Occasionally, the first evacuation of the furnace chamber would rupture the platinum envelope, causing loss of the sample.

The phases present in the "quenched" samples were identified from X-ray powder diffraction patterns because the opaque nature of the mixtures precluded identification when using a light microscope. A Norelco high-angle goniometer spectrometer with filtered Cu radiation was used for obtaining these patterns.

b. High-Temperature Tests

Two sample shapes were prepared for the high-temperature melting-point tests. Prisms $\frac{1}{16}$ in. by $\frac{1}{16}$ in. by 1 in. were pressed, without binder, and prefired in an argon atmosphere at a temperature about 100° C below the anticipated solidus temperature. One end was ground with a diamond wheel to produce a "pip" or fiber; the other end was inserted in the graphite screw (item "f" of fig. 17) above the heating element. The screw could be adjusted so that just the pip was

observable through the optical pyrometer sighting holes. The furnace chamber was twice evacuated (to an absolute pressure of 1×10^{-4} mm Hg) and filled with argon before the heating began. The sample was heated to within about 50 deg C of its solidus temperature in a few minutes and maintained at that temperature for about 15 minutes before heating was continued (5 deg C per 10 to 20 min). The first indication of change in shape of the pip was taken as the solidus temperature. At least three such determinations were made for each material reported. Unfortunately, this method and type of sample could not be used for determining the liquidus temperatures because the surface tensions of the mixtures studied were so great that a liquid drop would not fall off of the rod but would creep up, passing out of sight of the view holes.

Specimens for the liquidus-temperature determinations were prepared as short rods ($\frac{1}{16}$ in. in diameter by $\frac{1}{16}$ in. long) and prefired in an argon atmosphere at about 100° C below the anticipated solidus temperature. Then, each specimen was placed in a shall loop of 1- or 2-mil tungsten wire, which in turn was fastened to the graphite screw located above the heating element (fig. 17). The screw was adjusted so that the wire loop with the specimen could be observed through the optical pyrometer sighting holes. The atmosphere was prepared as described before. Again, the sample was heated to within about 50° C of the solidus temperature within a few minutes, maintained at that temperature for about 15 minutes, heated slowly (5 deg C per 10 to 15 min) to "check" the previously determined solidus temperature, and then heated slowly until what appeared to be complete melting occurred. For this preliminary determination, other specimens of the same mixture were heated above and below (50 to 100 deg C), the apparent temperature of complete melting. These temperatures were maintained for periods ranging from 10 to 30 minutes. Quenching was obtained by interruption of the furnace-heater power.

All of the quenched specimens were mounted in Lucite blocks and cut and polished to expose the approximate centers. Because of the opaque nature of UO_2 , the surfaces were examined with a reflected-light metallographic microscope. Examination of the grain sizes and the crystallization patterns permitted the determination of whether or not the samples had completely melted. Additional specimens, if necessary, were used to determine the approximate temperature of complete melting.

The actual determination of the liquidus temperature was then made as follows: A number of specimens were heated, singly, at a temperature high enough to insure complete melting; maintained at that temperature for 20 to 30 minutes; cooled to various temperatures (usually at 20-deg intervals) above and below the estimated liquidus temperature; maintained at temperature for 20 to 30 minutes; and quenched and examined. The temperature midway between appearance and disappearance of recrystallized grains was taken as the liquidus temperature. In most instances, equilibrium conditions at the high temperatures were attained within 10 to 15 minutes. Longer time intervals, but not over 1 hour, were necessary for some of the mixtures.

6. References

- [1] R. K. Hart, An electron diffraction study of oxide films on uranium, *Trans. Faraday Soc.* **49**, 299 (1953).
- [2] J. J. Katz and E. I. Rabinowitch, *The chemistry of uranium* (McGraw-Hill Book Co., New York, N. Y., 1951).
- [3] S. M. Lang, An annotated bibliography of selected references on the solid-state reactions of the uranium oxides, NBS Circ. 535 (January 9, 1953).
- [4] H. Hering and P. Perio, On the equilibrium of the uranium oxides between UO_2 and U_3O_8 , *Bul. soc. chim. (France)* p. 351, **1952**.
- [5] K. B. Alberman and J. S. Anderson, The oxides of uranium, *J. Chem. Soc., Suppl.* **2**, p. S303, **1949**.
- [6] P. Perio, The oxidation of UO_2 at low temperatures, *Bul. soc. chim. (France)*, p. 256, **1953**.
- [7] J. S. Anderson, Recent work on the chemistry of the uranium oxides, *Bul. soc. chim. (France)*, p. 781, **1953**.
- [8] L. E. J. Roberts, The oxides of uranium. Part V. The chemisorption of Oxygen on UO_2 and on $\text{UO}_2\text{-ThO}_2$ solid solutions, *J. Chem. Soc.*, p. 3332, **1954**.
- [9] H. R. Hoekstra, S. Siegel, L. H. Fuchs, and J. J. Katz, The uranium-oxygen system: $\text{UO}_{2.5}$ to U_3O_8 , *J. Phys. Chem.* **59**, 136 (1955).
- [10] C. A. Hutchison, Jr., and J. G. Malm, The volatilization of BeO in the presence of water, *J. Am. Chem. Soc.* **71**, 1338 (1949). L. Grossweiner, and R. L. Seifert, The reaction of beryllium oxide with water vapor, *J. Am. Chem. Soc.* **74**, 2701 (1952).
- [11] L. F. Epstein and W. H. Howland, Binary mixtures of UO_2 and other oxides, *J. Am. Ceram. Soc.* **36**, 334 (1953).
- [12] W. A. Lambertson and M. H. Mueller, Uranium oxide phase equilibrium systems; II, $\text{UO}_2\text{-MgO}$, *J. Am. Ceram. Soc.* **36**, 332 (1953).
- [13] J. S. Anderson and K. D. B. Johnson, The oxides of uranium, Part III—The system $\text{UO}_2\text{-MgO-O}$, *J. Chem. Soc.*, p. 1731, **1953**.
- [14] K. B. Alberman, R. C. Blakey, and J. S. Anderson, The oxides of uranium, Part II—The binary system $\text{UO}_2\text{-CaO}$, *J. Chem. Soc.*, p. 1352, **1951**.
- [15] H. D. Megaw, Ferroelectricity and crystal structure, II, *Acta Cryst.* **1**, 187 (1954).
- [16] W. A. Lambertson and M. H. Mueller, Uranium oxide phase equilibrium systems: I, $\text{UO}_2\text{-Al}_2\text{O}_3$, *J. Am. Ceram. Soc.* **36**, 329 (1953).
- [17] W. A. Lambertson and M. H. Mueller, Uranium oxide phase equilibrium systems: V, $\text{UO}_2\text{-Nd}_2\text{O}_3$, . . . U. S. AEC unclassified report ANL-5312 (Sept. 14, 1954).
- [18] W. A. Lambertson and M. H. Mueller, Uranium oxide phase equilibrium systems: III, $\text{UO}_2\text{-ZrO}_2$, *J. Am. Ceram. Soc.* **36**, 365 (1953).
- [19] W. A. Lambertson, M. H. Mueller, and F. H. Gunzel, Jr., Uranium oxide phase equilibrium systems: IV, $\text{UO}_2\text{-ThO}_2$, *J. Am. Ceram. Soc.* **36**, 397 (1953).
- [20] H. von Wartenberg and E. Prophet, Melting diagrams of refractory oxides, Part V, *Z. anorg. allgem. Chem.* **208**, 369 (1932); Part II, **208**, 380 (1932).
- [21] W. M. Cohen, Crystal modifications of zirconia; A clear, fused zirconia produced in the sun furnace, *Trans. Electrochem. Soc.* **65**, 65 (1935).
- [22] J. W. Stout, Second-order transformation of two-component systems; Applications to solutions of He^3 in He^4 , *Phys. Rev.* **74**, 605 (1948).
- [23] J. S. Bowles, C. S. Barrett, and L. Guttman, Crystallography of cubic-tetragonal transformation in the indium-thallium system, *J. Metals* (December 1950); *Trans. Amer. Inst. Mining Met. Engrs.* **188**, 1478 (1950).
- [24] K. A. Hofman and K. Hoschele, Magnesium chloride as a mineralizer. II—Uranium-cerium blue and the nature of constitutive coloring. Magnesium red and magnesium green, *Ber. deut. keram. Ges.* **48**, 20 (1915).
- [25] A. Magneli and L. Kihlberg, On the cerium dioxide-uranium dioxide system and cerium uranium blue, *Act. Chem. Scand.* **5**, 578 (1951).
- [26] W. Rudorff and G. Valet, On cerium-uranium blue and the semi-conductive properties of the mixed crystal series $\text{UO}_2\text{-CeO}_2$, *Z. Naturforsch.* **7b**, 57 (1952).
- [27] F. Hund, R. Wagner, and U. Peetz, Abnormal mixed-crystals in the system cerium oxide-uranium oxide, *Z. Electrochem.* **56**, 61 (1952).
- [28] W. Trzebiatowski and P. W. Selwood, Magnetic susceptibilities of uranium-thoria solid solutions, *J. Am. Chem. Soc.* **72**, 4504 (1950).

- [29] E. Slowinski and N. Elliott, Lattice constants and magnetic susceptibilities of solid solutions of uranium and thorium dioxide, *Acta Cryst.* **5**, 768 (1952).
- [30] H. E. Swanson and E. Tatge, Standard X-ray diffraction powder patterns, NBS Circ. 539, **1** (June 15, 1953).
- [31] L. Vegard, *Z. Physik* **5**, 17 (1921).
- [32] F. Hund and G. Niessen, Abnormal mixed crystals in the system thorium oxide-uranium oxide, *Z. Elektrochem.* **56**, 972 (1952).
- [33] J. S. Anderson, N. D. Edgington, L. E. J. Roberts, and E. Wait, The oxides of uranium. Part IV. The system $\text{UO}_2\text{-ThO}_2\text{-O}$, *J. Chem. Soc.*, p. 3324, **1954**.
- [34] B. F. Scribner, Chief, Spectrochemistry Section, Division of Chemistry, NBS, private communication (March 23, 1951).
- [35] H. E. Swanson and R. F. Fuyat, Standard X-ray diffraction powder patterns, NBS Circ. 539, **II**, (June 15, 1953).
- [36] B. Zweig, Periodic level controller for liquid nitrogen, *Rev. Sci. Instr.* **22**, 431 (1951).
- [37] G. K. Burgess, A micropyrometer, *Bul. BS* **9**, 475 (1913) S198; G. K. Burgess and R. G. Waltenberg, Melting points of the refractory elements—I. Elements of atomic weight 48 to 59, **10**, 79 (1914) S205; G. K. Burgess and R. G. Waltenberg, The emissivity of metals and oxides. II. Measurements with the micropyrometer, **11**, 591 (1915) S242.
- [38] W. O. Stratton, The phase diagram of the BaO-TiO_2 system, *J. Chem. Phys.* **19**, 33 (1951).



